

# FCC LTE REPORT

## FCC Certification

**Applicant Name:**

LG Electronics MobileComm U.S.A., Inc.

**Date of Issue:**

August 19, 2016

**Location:**

HCT CO., LTD.,

**Address:**

1000 Sylvan Avenue, Englewood Cliffs NJ 07632

74, Seoicheon-ro 578beon-gil, Majang-myeon,

Icheon-si, Gyeonggi-do, 17383, Rep. of KOREA

**Report No.:** HCT-R-1608-F018

**HCT FRN:** 0005866421

**FCC ID:**

**ZNFH990**

**APPLICANT:**

**LG Electronics MobileComm U.S.A., Inc.**

**FCC Model(s):** LG-H990  
**Additional FCC Model(s):** LG-H990TR, LG-H990ds  
**EUT Type:** GSM/WCDMA/LTE Phone with Bluetooth, WLAN, NFC  
**FCC Classification:** Licensed Portable Transmitter Held to Ear (PCE)  
**FCC Rule Part(s):** §27, §2

| Mode (MHz)       | Tx Frequency (MHz) | Emission Designator | Modulation | EIRP           |                  |
|------------------|--------------------|---------------------|------------|----------------|------------------|
|                  |                    |                     |            | Max. Power (W) | Max. Power (dBm) |
| LTE – Band7 (5)  | 2502.5 – 2567.5    | 4M51G7D             | QPSK       | 0.097          | 19.87            |
|                  |                    | 4M50W7D             | 16QAM      | 0.080          | 19.03            |
| LTE – Band7 (10) | 2505.0 – 2565.0    | 8M98G7D             | QPSK       | 0.102          | 20.07            |
|                  |                    | 8M98W7D             | 16QAM      | 0.087          | 19.38            |
| LTE – Band7 (15) | 2507.5 – 2562.5    | 13M5G7D             | QPSK       | 0.100          | 19.98            |
|                  |                    | 13M5W7D             | 16QAM      | 0.084          | 19.23            |
| LTE – Band7 (20) | 2510.0 – 2560.0    | 18M0G7D             | QPSK       | 0.099          | 19.98            |
|                  |                    | 18M0W7D             | 16QAM      | 0.087          | 19.39            |

The measurements shown in this report were made in accordance with the procedures specified in CFR47 section §2.947. I assume full responsibility for the accuracy and completeness of these measurements, and for the qualifications of all persons taking them.

**HCT CO., LTD.** Certifies that no party to this application has subject to a denial of Federal benefits that includes FCC benefits pursuant to section 5301 of the Anti-Drug Abuse Act of 1998,21 U.S. C.853(a)



**Report prepared by**  
**: Jeong Ho Kim**  
**Test engineer of RF Team**



**Approved by**  
**: Kyoung Houn Seo**  
**Manager of RF Team**

This report only responds to the tested sample and may not be reproduced, except in full, without written approval of the HCT Co., Ltd.

## Version

| TEST REPORT NO. | DATE            | DESCRIPTION             |
|-----------------|-----------------|-------------------------|
| HCT-R-1608-F018 | August 19, 2016 | - First Approval Report |
|                 |                 |                         |
|                 |                 |                         |
|                 |                 |                         |

---

---

# Table of Contents

|  |    |
|--|----|
| 1. GENERAL INFORMATION .....                                     | 4  |
| 2. INTRODUCTION .....  | 5  |
| 2.1. EUT DESCRIPTION.....  | 5  |
| 2.2. MEASURING INSTRUMENT CALIBRATION.....                       | 5  |
| 2.3. TEST FACILITY .....   | 5  |
| 3. DESCRIPTION OF TESTS .....                                    | 6  |
| 3.1 EIRP RADIATED POWER AND RADIATED SPURIOUS EMISSIONS .....    | 6  |
| 3.2 OCCUPIED BANDWIDTH. ....                                     | 7  |
| 3.3 SPURIOUS AND HARMONIC EMISSIONS AT ANTENNA TERMINAL.....     | 8  |
| 3.4 FREQUENCY STABILITY / VARIATION OF AMBIENT TEMPERATURE ..... | 9  |
| 4. LIST OF TEST EQUIPMENT .....                                  | 10 |
| 5. MEASUREMENT UNCERTAINTY .....                                 | 11 |
| 6. SUMMARY OF TEST RESULTS .....                                 | 12 |
| 7. SAMPLE CALCULATION.....                                       | 13 |
| 8. TEST DATA .....   | 14 |
| 8.1 EQUIVALENT ISOTROPIC RADIATED POWER (Band 7) .....           | 14 |
| 8.2 RADIATED SPURIOUS EMISSIONS.....                             | 16 |
| 8.2.1 RADIATED SPURIOUS EMISSIONS (5 MHz Band 7 LTE) .....       | 16 |
| 8.2.2 RADIATED SPURIOUS EMISSIONS (10 MHz Band 7 LTE) .....      | 17 |
| 8.2.3 RADIATED SPURIOUS EMISSIONS (15 MHz Band 7 LTE) .....      | 18 |
| 8.2.4 RADIATED SPURIOUS EMISSIONS (20 MHz Band 7 LTE) .....      | 19 |
| 8.3 OCCUPIED BANDWIDTH .....                                     | 20 |
| 8.4 CONDUCTED SPURIOUS EMISSIONS .....                           | 21 |
| 8.4.1 BAND EDGE.....   | 22 |
| 8.5 FREQUENCY STABILITY / VARIATION OF AMBIENT TEMPERATURE ..... | 23 |
| 8.5.1 FREQUENCY STABILITY (5 MHz Band 7 LTE) .....               | 23 |
| 8.5.2 FREQUENCY STABILITY (10 MHz Band 7 LTE) .....              | 24 |
| 8.5.3 FREQUENCY STABILITY (15 MHz Band 7 LTE) .....              | 25 |
| 8.5.4 FREQUENCY STABILITY (20 MHz Band 7 LTE) .....              | 26 |
| 9. TEST PLOTS.....   | 27 |

# MEASUREMENT REPORT

## 1. GENERAL INFORMATION

**Applicant Name:** LG Electronics MobileComm U.S.A., Inc.

**Address:** 1000 Sylvan Avenue, Englewood Cliffs NJ 07632

**FCC ID:** ZNFH990

**Application Type:** Certification

**FCC Classification:** Licensed Portable Transmitter Held to Ear (PCE)

**FCC Rule Part(s):** §2 , §27

**EUT Type:** GSM/WCDMA/LTE Phone with Bluetooth, WLAN, NFC

**FCC Model(s):** LG-H990

**Additional FCC Model(s):** LG-H990TR, LG-H990ds

**Tx Frequency:** 2502.5 MHz – 2567.5 MHz (LTE – Band 7): 5 MHz  
2505.0 MHz – 2565.0 MHz (LTE – Band 7): 10 MHz  
2507.5 MHz – 2562.5 MHz (LTE – Band 7): 15 MHz  
2510.0 MHz – 2560.0 MHz (LTE – Band 7): 20 MHz

**Max. RF Output Power:**

|                   |                              |
|-------------------|------------------------------|
| Band 7 (5 MHz) :  | 0.097 W (QPSK) (19.87 dBm)   |
|                   | 0.080 W (16-QAM) (19.03 dBm) |
| Band 7 (10 MHz) : | 0.102 W (QPSK) (20.07 dBm)   |
|                   | 0.087 W (16-QAM) (19.38 dBm) |
| Band 7 (15 MHz) : | 0.100 W (QPSK) (19.98 dBm)   |
|                   | 0.084 W (16-QAM) (19.23 dBm) |
| Band 7 (20 MHz) : | 0.099 W (QPSK) (19.98 dBm)   |
|                   | 0.087 W (16-QAM) (19.39 dBm) |

**Emission Designator(s):**

|                   |                                   |
|-------------------|-----------------------------------|
| Band 7 (5 MHz) :  | 4M51G7D (QPSK) / 4M50W7D (16-QAM) |
| Band 7 (10 MHz) : | 8M98G7D (QPSK) / 8M98W7D (16-QAM) |
| Band 7 (15 MHz) : | 13M5G7D (QPSK) / 13M5W7D (16-QAM) |
| Band 7 (20 MHz) : | 18M0G7D (QPSK) / 18M0W7D (16-QAM) |

**Date(s) of Tests:** July 19, 2016 ~ August 19, 2016

**Antenna Specification:**

|               |                                  |
|---------------|----------------------------------|
| Manufacturer: | Ace Technology                   |
| Antenna type: | PIFA Antenna (Planar Inverted F) |
| Peak Gain:    | Band 7: -1.0 dBi                 |

## **2. INTRODUCTION**

### **2.1. EUT DESCRIPTION**

The LG Electronics MobileComm U.S.A., Inc. LG-H990 GSM/WCDMA/LTE Phone with Bluetooth, WLAN, NFC consists of LTE 7.

### **2.2. MEASURING INSTRUMENT CALIBRATION**

The measuring equipment, which was utilized in performing the tests documented herein, has been calibrated in accordance with the manufacturer's recommendations for utilizing calibration equipment, which is traceable to recognized national standards.

### **2.3. TEST FACILITY**

The Fully-anechoic chamber and conducted measurement facility used to collect the radiated data are located at the **74, Seoicheon-ro 578beon-gil, Majang-myeon, Icheon-si, Gyeonggi-do, 17383, Rep. of KOREA.**

## **3. DESCRIPTION OF TESTS**

### **3.1 EIRP RADIATED POWER AND RADIATED SPURIOUS EMISSIONS**

Note: EIRP(Equivalent Isotropic Radiated Power)

Test Procedure

Radiated emission measurements are performed in the Fully-anechoic chamber. The equipment under test is placed on a non-conductive table 3-meters away from the receive antenna in accordance with ANSI/TIA-603-D-2010 Clause 2.2.17. The turntable is rotated through 360 degrees, and the receiving antenna scans in order to determine the level of the maximized emission. The level and position of the maximized emission is recorded with the spectrum analyzer using RMS detector.

A half wave dipole is then substituted in place of the EUT. For emissions above 1GHz, a horn antenna is substituted in place of the EUT. The substitute antenna is driven by a signal generator and the previously recorded signal was duplicated.

The power is calculated by the following formula;

$$P_{d(\text{dBm})} = P_{g(\text{dBm})} - \text{cable loss (dB)} + \text{antenna gain (dB)}$$

Where:  $P_d$  is the dipole equivalent power and  $P_g$  is the generator output power into the substitution antenna.

The maximum EIRP is calculated by adding the forward power to the calibrated source plus its appropriate gain value. These steps are repeated with the receiving antenna in both vertical and horizontal polarization. the difference between the gain of the horn and an isotropic antenna are taken into consideration

#### **Radiated spurious emissions**

1. Frequency Range : 30 MHz ~ 10<sup>th</sup> Harmonics of highest channel fundamental frequency.
2. Measured distance : 30 MHz ~ 11 GHz at 3 m  
11 GHz ~ 26 GHz at 1m
3. The EUT was setup to maximum output power. The 100 kHz RBW was used to scan from 30 MHz to 1 GHz. Also, the 1 MHz RBW was used to scan from 1 GHz to 26.5 GHz. And limit is -25 dBm. The high, low and a middle channel were tested for out of band measurements.

### 3.2 OCCUPIED BANDWIDTH.

#### Test set-up

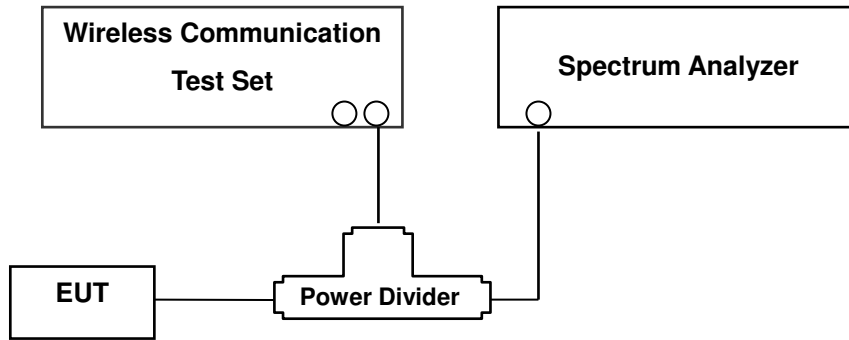

(Configuration of conducted Emission measurement)

The width of a frequency band such that, below the lower and above the upper frequency limits, the mean powers emitted are each equal to a specified percentage 0.5 % of the total mean power of a given emission.

#### Test Procedure

OBW is tested in accordance with KDB971168 D01 Power Meas License Digital Systems v02r02, October 17, 2014, Section 4.2.

The EUT makes a call to the communication simulator. The power was measured with R&S Spectrum Analyzer. All measurements were done at 3 channels(low, middle and high operational range.)

The conducted occupied bandwidth used the power splitter via EUT RF power connector between simulation base station and spectrum analyzer.

The communication simulator station system controlled a EUT to export maximum output power under transmission mode and specific channel frequency. Use OBW measurement function of Spectrum analyzer to measure 99 % occupied bandwidth

### 3.3 SPURIOUS AND HARMONIC EMISSIONS AT ANTENNA TERMINAL.

#### Test Procedure

Spurious and harmonic emissions at antenna terminal is tested in accordance with KDB971168 D01 Power Meas License Digital Systems v02r02, October 17, 2014, Section 6.0.

The level of the carrier and the various conducted spurious and harmonic frequencies is measured by means of a calibrated spectrum analyzer.

The EUT was setup to maximum output power. The 1 MHz RBW was used to scan from 30 MHz to 26.5 GHz. And limit is -25 dBm. The high, low and a middle channel were tested for out of band measurements.

- Channel Edge Requirement : In the 1 MHz bands immediately outside and adjacent to the channel, a resolution bandwidth of at least 1 percent of the emission bandwidth of the fundamental emission of the transmitter may be employed to measure the out of band Emissions.

**NOTES:** The analyzer plot offsets were determined by below conditions.

- For LTE Band 7, total offset 27.6 dBm = 20 dBm attenuator + 6 dBm Divider + 1.6 dBm RF cables.



### 3.4 FREQUENCY STABILITY / VARIATION OF AMBIENT TEMPERATURE

#### Test Set-up

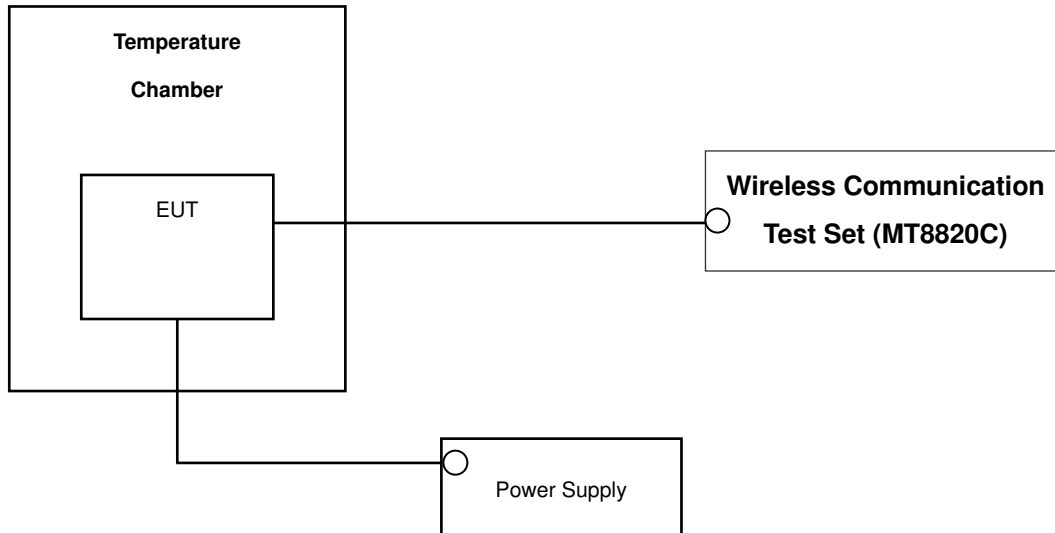

\* Nominal Operating Voltage

#### Test Procedure

Frequency stability is tested in accordance with ANSI/TIA-603-D-2010 section 2.2.2.

The frequency stability of the transmitter is measured by:

- a.) **Temperature:** The temperature is varied from - 30 °C to + 50 °C using an environmental chamber.
- b.) **Primary Supply Voltage:** The primary supply voltage is varied from battery end point to 100 % of the voltage normally at the input to the device or at the power supply terminals if cables are not normally supplied.

Specification — the frequency stability shall be sufficient to ensure that the fundamental emission stays within the authorized frequency block .

#### Time Period and Procedure:

The carrier frequency of the transmitter is measured at room temperature (20°C to provide a reference).

1. The equipment is turned on in a "standby" condition for one minute before applying power to the transmitter. Measurement of the carrier frequency of the transmitter is made within one minute after applying power to the transmitter.
2. Frequency measurements are made at 10°C intervals ranging from -30°C to +50°C. A period of at least one half-hour is provided to allow stabilization of the equipment at each temperature level.

**NOTE: The EUT is tested down to the battery endpoint.**

## 4. LIST OF TEST EQUIPMENT

| Manufacture     | Model/ Equipment                            | Serial Number          | Calibration Interval | Calibration Due |
|-----------------|---|------------------------|----------------------|-----------------|
| MITEQ           | AMF-6D-001180-35-20P/AMP                    | 1081666                | Annual               | 09/03/2016      |
| Wainwright      | WHK1.2/15G-10EF/H.P.F                       | 4                      | Annual               | 04/11/2017      |
| Wainwright      | WHK3.3/18G-10EF/H.P.F                       | 2                      | Annual               | 04/11/2017      |
| Hewlett Packard | 11667B / Power Splitter                     | 10545                  | Annual               | 02/15/2017      |
| Hewlett Packard | 11667B / Power Splitter                     | 11275                  | Annual               | 04/29/2017      |
| Agilent         | E3632A/DC Power Supply                      | KR75303243             | Annual               | 07/12/2017      |
| Schwarzbeck     | UHAP/ Dipole Antenna                        | 557                    | Biennial             | 03/23/2017      |
| Schwarzbeck     | UHAP/ Dipole Antenna                        | 558                    | Biennial             | 03/23/2017      |
| EXP             | EX-TH400/ Chamber                           | None                   | Annual               | 05/31/2017      |
| Schwarzbeck     | BBHA 9120D/ Horn Antenna                    | 147                    | Biennial             | 09/01/2016      |
| Schwarzbeck     | BBHA 9120D/ Horn Antenna                    | 1299                   | Biennial             | 05/15/2017      |
| Schwarzbeck     | BBHA 9170/ Horn Antenna(15~40GHz)           | BBHA9170342            | Biennial             | 04/30/2017      |
| Schwarzbeck     | BBHA 9170/ Horn Antenna(15~35GHz)           | BBHA9170124            | Biennial             | 04/30/2017      |
| Agilent         | N9020A/Signal Analyzer                      | MY52090906             | Annual               | 05/13/2017      |
| Hewlett Packard | 8493C/ATTENUATOR                            | 17280                  | Annual               | 06/22/2017      |
| REOHDE&SCHWARZ  | FSV40/Spectrum Analyzer                     | 1307.9002K40-100931-NK | Annual               | 06/15/2017      |
| Agilent         | 8960 (E5515C)/ Base Station                 | MY48360800             | Annual               | 10/30/2016      |
| Anritsu Corp.   | MT8820C/Wideband Radio Communication Tester | 6200863156             | Annual               | 02/26/2017      |
| Anritsu Corp.   | MT8820C/Wideband Radio Communication Tester | 6201026545             | Annual               | 02/16/2017      |
| Schwarzbeck     | VULB9160/ Bilog Antenna                     | 3150                   | Biennial             | 11/17/2016      |
| Schwarzbeck     | VULB9160/ Bilog Antenna                     | 3368                   | Biennial             | 10/10/2016      |

## 5. MEASUREMENT UNCERTAINTY

The measurement uncertainties shown below were calculated in accordance with the requirements of ANSI C63.4:2014.

All measurement uncertainty values are shown with a coverage factor of  $k = 2$  to indicate a 95 % level of confidence. The measurement data shown herein meets or exceeds the  $U_{\text{CISPR}}$  measurement uncertainty values specified in CISPR 16-4-2 and, thus, can be compared directly to specified limits to determine compliance.

| Parameter                                | Expanded Uncertainty ( $\pm$ dB) |
|--|----------------------------------|
| Conducted Disturbance (150 kHz ~ 30 MHz) | 1.82                             |
| Radiated Disturbance (9 kHz ~ 30 MHz)    | 3.40                             |
| Radiated Disturbance (30 MHz ~ 1 GHz)    | 4.80                             |
| Radiated Disturbance (1 GHz ~ 18 GHz)    | 6.07                             |

## 6. SUMMARY OF TEST RESULTS

| FCC Part Section(s)    | Test Description                             | Test Limit  | Test Condition | Test Result |
|------------------------|--|---|----------------|-------------|
| 2.1049                 | Occupied Bandwidth                           | N/A   | CONDUCTED      | PASS        |
| 2.1051,<br>27.53(m)(4) | Band Edge /<br>Conducted Spurious Emissions. | < 40 + 10log10 (P[Watts])<br>at Channel edges<br>< 43 + 10log10 (P[Watts])<br>between 5 and X MHz<br>from Channel edges<br>< 55 + 10log10 (P[Watts])<br>beyond X MHz beyond<br>from Channel edges |                | PASS        |
| 2.1046                 | * Conducted Output Power                     | N/A   |                | PASS        |
| 2.1055,<br>27.54       | Frequency stability                          | Emission must remain in band  |                | PASS        |
| 27.50(h)(2)            | Equivalent Isotropic Radiated<br>Power       | < 2 Watts max. EIRP   | RADIATED       | PASS        |
| 2.1053,<br>27.53(m)(4) | Undesirable Emissions                        | < 40 + 10log10 (P[Watts])<br>at Channel edges<br>< 43 + 10log10 (P[Watts])<br>between 5 and X MHz<br>from Channel edges<br>< 55 + 10log10 (P[Watts])<br>beyond X MHz beyond<br>from Channel edges |                | PASS        |

\*: See SAR Report

## 7. SAMPLE CALCULATION

### A. EIRP Sample Calculation

| Mode      | Ch./ Freq. |            | Measured Level(dBm) | Substitute LEVEL(dBm) | Ant. Gain (dBi) | C.L  | Pol. | Limit W | EIRP |       |
|-----------|------------|------------|---------------------|-----------------------|-----------------|------|------|---------|------|-------|
|           | channel    | Freq.(MHz) |                     |                       |                 |      |      |         | W    | dBm   |
| LTE Band7 | 21100      | 2,535.00   | -15.36              | 19.46                 | 10.72           | 1.78 | V    | < 2.00  | 0.69 | 28.40 |

#### EIRP = Substitute LEVEL(dBm) + Ant. Gain – CL(Cable Loss)

- 1) The EUT mounted on a wooden tripod is 2.5 meter above test site ground level.
- 2) During the test , the turn table is rotated until the maximum signal is found.
- 3) Record the field strength meter's level.
- 4) Replace the EUT with dipole/Horn antenna that is connected to a calibrated signal generator.
- 5) Increase the signal generator output till the field strength meter's level is equal to the item (3).
- 6) The signal generator output level with Ant. Gain and cable loss are the rating of Equivalent Isotropic Radiated Power (**EIRP**).

## B. Emission Designator

### QPSK Modulation

**Emission Designator = 4M48G7D**

LTE BW = 4.48 MHz

G = Phase Modulation

7 = Quantized/Digital Info

D = Data transmission; telemetry; telecommand

### 16QAM Modulation

**Emission Designator = 4M48W7D**

LTE BW = 4.48 MHz

W = main carrier modulated in a combination of two

or more of the following modes;

amplitude, angle, pulse

7 = Quantized/Digital Info

D = Data transmission; telemetry; telecommand

## 8. TEST DATA

### 8.1 EQUIVALENT ISOTROPIC RADIATED POWER (Band 7)

| Freq (MHz) | Bandwidth | Modulation | Measured Level (dBm) | Substitute Level (dBm) | Ant. Gain(dBi) | C.L  | Pol | Limit  | EIRP  |       |
|------------|-----------|------------|----------------------|------------------------|----------------|------|-----|--------|-------|-------|
|            |           |            |                      |                        |                |      |     | W      | W     | dBm   |
| 2502.5     | 5 MHz     | QPSK       | -24.71               | 11.72                  | 10.95          | 2.87 | H   | < 2.00 | 0.095 | 19.80 |
|            |           | 16-QAM     | -25.50               | 10.93                  | 10.95          | 2.87 | H   |        | 0.080 | 19.01 |
| 2535.0     |           | QPSK       | -24.65               | 11.84                  | 10.98          | 2.95 | H   |        | 0.097 | 19.87 |
|            |           | 16-QAM     | -25.49               | 11.00                  | 10.98          | 2.95 | H   |        | 0.080 | 19.03 |
| 2567.5     |           | QPSK       | -26.27               | 10.51                  | 11.00          | 2.97 | H   |        | 0.071 | 18.54 |
|            |           | 16-QAM     | -27.01               | 9.77                   | 11.00          | 2.97 | H   |        | 0.060 | 17.80 |

Equivalent Isotropic Radiated Power Data (5 MHz Band 7 LTE)

Note: All of RB size has been tested for emissions and EIRP, with the 1RB configuration observed as the worst case

| Freq (MHz) | Bandwidth | Modulation | Measured Level (dBm) | Substitute Level (dBm) | Ant. Gain(dBi) | C.L  | Pol | Limit  | EIRP  |       |
|------------|-----------|------------|----------------------|------------------------|----------------|------|-----|--------|-------|-------|
|            |           |            |                      |                        |                |      |     | W      | W     | dBm   |
| 2505.0     | 10 MHz    | QPSK       | -24.60               | 11.80                  | 10.95          | 2.88 | H   | < 2.00 | 0.097 | 19.87 |
|            |           | 16-QAM     | -25.36               | 11.04                  | 10.95          | 2.88 | H   |        | 0.082 | 19.11 |
| 2535.0     |           | QPSK       | -24.45               | 12.04                  | 10.98          | 2.95 | H   |        | 0.102 | 20.07 |
|            |           | 16-QAM     | -25.14               | 11.35                  | 10.98          | 2.95 | H   |        | 0.087 | 19.38 |
| 2565.0     |           | QPSK       | -25.95               | 10.83                  | 11.00          | 2.97 | H   |        | 0.077 | 18.86 |
|            |           | 16-QAM     | -26.66               | 10.12                  | 11.00          | 2.97 | H   |        | 0.065 | 18.15 |

Equivalent Isotropic Radiated Power Data (10 MHz Band 7 LTE)

Note: All of RB size has been tested for emissions and EIRP, with the 1RB configuration observed as the worst case

| Freq (MHz) | Bandwidth | Modulation | Measured Level (dBm) | Substitute Level (dBm) | Ant. Gain(dBi) | C.L  | Pol | Limit  | EIRP  |       |
|------------|-----------|------------|----------------------|------------------------|----------------|------|-----|--------|-------|-------|
|            |           |            |                      |                        |                |      |     | W      | W     | dBm   |
| 2507.5     | 15 MHz    | QPSK       | -24.40               | 11.91                  | 10.96          | 2.89 | H   | < 2.00 | 0.100 | 19.98 |
|            |           | 16-QAM     | -25.15               | 11.16                  | 10.96          | 2.89 | H   |        | 0.084 | 19.23 |
| 2535.0     |           | QPSK       | -24.65               | 11.84                  | 10.98          | 2.95 | H   |        | 0.097 | 19.87 |
|            |           | 16-QAM     | -25.46               | 11.03                  | 10.98          | 2.95 | H   |        | 0.081 | 19.06 |
| 2562.5     |           | QPSK       | -25.29               | 11.52                  | 11.00          | 2.97 | H   |        | 0.090 | 19.55 |
|            |           | 16-QAM     | -26.18               | 10.63                  | 11.00          | 2.97 | H   |        | 0.073 | 18.66 |

Equivalent Isotropic Radiated Power Data (15 MHz Band 7 LTE)

Note: All of RB size has been tested for emissions and EIRP, with the 1RB configuration observed as the worst case

| Freq (MHz) | Bandwidth | Modulation | Measured Level (dBm) | Substitute Level (dBm) | Ant. Gain(dBi) | C.L  | Pol | Limit  | EIRP  |       |
|------------|-----------|------------|----------------------|------------------------|----------------|------|-----|--------|-------|-------|
|            |           |            |                      |                        |                |      |     | W      | W     | dBm   |
| 2510.0     | 20 MHz    | QPSK       | -24.46               | 11.91                  | 10.96          | 2.89 | H   | < 2.00 | 0.099 | 19.98 |
|            |           | 16-QAM     | -25.05               | 11.32                  | 10.96          | 2.89 | H   |        | 0.087 | 19.39 |
| 2535.0     |           | QPSK       | -25.14               | 11.35                  | 10.98          | 2.95 | H   |        | 0.087 | 19.38 |
|            |           | 16-QAM     | -25.47               | 11.02                  | 10.98          | 2.95 | H   |        | 0.080 | 19.05 |
| 2560.0     |           | QPSK       | -25.26               | 11.55                  | 11.00          | 2.97 | H   |        | 0.091 | 19.58 |
|            |           | 16-QAM     | -26.13               | 10.68                  | 11.00          | 2.97 | H   |        | 0.074 | 18.71 |

Equivalent Isotropic Radiated Power Data (20 MHz Band 7 LTE)

Note: All of RB size has been tested for emissions and EIRP, with the 1RB configuration observed as the worst case

NOTES:

Equivalent Isotropic Radiated Power Measurements by Substitution Method

according to ANSI/TIA/EIA-603-D-2010 June 24, 2010:

The EUT was placed on a non-conductive styrofoam resin table 3-meters from the receive antenna. The receive antenna height and turntable rotation was adjusted for the highest reading on the receive spectrum analyzer. For 5 MHz, 10MHz BW signals, RBW = 1-5% of the OBW, not to exceed 1MHz, VBW ≥ 3 x RBW, Detector = RMS. A Horn antenna was substituted in place of the EUT. This dipole antenna was driven by a signal generator and the level of the signal generator was adjusted to obtain the same receive spectrum analyzer reading. The conducted power at the terminals of the Horn antenna is measured. The difference between the gain of the horn and an isotropic antenna is taken into consideration and the EIRP is recorded.

Also, we have done x, y, z planes in EUT and horizontal and vertical polarization in detecting antenna. The worst case of the EUT is x plane in LTE mode. Also worst case of detecting Antenna is horizontal polarization in LTE mode.

## 8.2 RADIATED SPURIOUS EMISSIONS

### 8.2.1 RADIATED SPURIOUS EMISSIONS (5 MHz Band 7 LTE)

- ▣ OPERATING FREQUENCY : 2535.00 MHz
- ▣ MEASURED OUTPUT POWER: 19.87 dBm = 0.097 W
- ▣ MODULATION SIGNAL: 5 MHz QPSK
- ▣ DISTANCE: 3 meters
- ▣ LIMIT:  $55 + 10 \log_{10}(W) =$  44.87 dBc

| Ch                | Freq (MHz) | Measured Level (dBm) | Ant. Gain (dBi) | Substitute Level (dBm) | C.L  | Pol | EIRP (dBm) | dBc   |
|-------------------|------------|----------------------|-----------------|------------------------|------|-----|------------|-------|
| 20775<br>(2502.5) | 5,005.00   | -62.26               | 12.57           | -67.31                 | 4.49 | H   | -59.23     | 79.10 |
|                   | 7,507.50   | -56.46               | 11.70           | -52.65                 | 5.69 | V   | -46.64     | 66.51 |
|                   | 10,010.00  | -66.11               | 11.01           | -55.43                 | 6.84 | H   | -51.26     | 71.13 |
|                   | 12,512.50  | -56.97               | 14.04           | -53.33                 | 7.49 | V   | -46.78     | 66.65 |
|                   | 15,015.00  | -54.59               | 13.37           | -50.96                 | 8.74 | H   | -46.33     | 66.20 |
| 21100<br>(2535.0) | 5,070.00   | -62.50               | 12.67           | -66.70                 | 4.56 | H   | -58.59     | 78.46 |
|                   | 7,605.00   | -58.33               | 11.63           | -54.09                 | 5.67 | V   | -48.13     | 68.00 |
|                   | 10,140.00  | -67.23               | 10.94           | -58.19                 | 6.66 | H   | -53.91     | 73.78 |
|                   | 12,675.00  | -57.20               | 13.85           | -53.29                 | 7.44 | V   | -46.88     | 66.75 |
|                   | 15,210.00  | -53.15               | 14.41           | -52.11                 | 8.61 | H   | -46.31     | 66.18 |
| 21425<br>(2567.5) | 5,135.00   | -55.79               | 12.76           | -61.77                 | 4.57 | V   | -53.58     | 73.45 |
|                   | 7,702.50   | -60.02               | 11.56           | -55.72                 | 5.84 | V   | -50.00     | 69.87 |
|                   | 10,270.00  | -65.45               | 10.87           | -57.25                 | 6.78 | H   | -53.16     | 73.03 |
|                   | 12,837.50  | -57.98               | 13.65           | -53.83                 | 7.49 | V   | -47.67     | 67.54 |
|                   | 15,405.00  | -52.94               | 15.47           | -52.25                 | 8.66 | H   | -45.44     | 65.31 |

- NOTES:**
1. Radiated Spurious Emission Measurements at 1 meter and 3 meter by Substitution Method according to ANSI/TIA/EIA-603-D-2010 June 24, 2010:
  2. We are performed all frequency to 10<sup>th</sup> harmonics from 30 MHz. Measurements above show only up to 3 maximum emissions noted, or would be lesser if no specific emissions from the EUT are recorded (ie: margin > 20 dB from the applicable limit) and considered that's already beyond the background noise floor.
  3. We have done x, y, z planes in EUT and horizontal and vertical polarization in detecting antenna.
  4. All of RB size has been tested for emissions and EIRP, with the 1RB configuration observed as the worst case
  5. We are performed 16QAM and QPSK modulations. The worst case data are reported in the table above.



**8.2.2 RADIATED SPURIOUS EMISSIONS (10 MHz Band 7 LTE)**

- ▣ OPERATING FREQUENCY : 2535.00 MHz
- ▣ MEASURED OUTPUT POWER: 20.07 dBm = 0.102 W
- ▣ MODULATION SIGNAL: 10 MHz QPSK
- ▣ DISTANCE: 3 meters
- ▣ LIMIT:  $55 + 10 \log_{10}(W) =$  45.07 dBc

| Ch                | Freq (MHz) | Measured Level (dBm) | Ant. Gain (dBi) | Substitute Level (dBm) | C.L  | Pol | EIRP (dBm) | dBc   |
|-------------------|------------|----------------------|-----------------|------------------------|------|-----|------------|-------|
| 20800<br>(2505.0) | 5,010.00   | -54.43               | 12.58           | -59.56                 | 4.48 | V   | -51.46     | 71.53 |
|                   | 7,515.00   | -55.60               | 11.70           | -52.15                 | 5.69 | V   | -46.14     | 66.21 |
|                   | 10,020.00  | -65.72               | 11.01           | -55.61                 | 7.01 | V   | -51.61     | 71.68 |
|                   | 12,525.00  | -56.25               | 14.01           | -52.46                 | 7.45 | V   | -45.90     | 65.97 |
|                   | 15,030.00  | -54.54               | 13.44           | -50.65                 | 8.83 | H   | -46.04     | 66.11 |
| 21100<br>(2535.0) | 5,070.00   | -52.44               | 12.67           | -56.64                 | 4.56 | V   | -48.53     | 68.60 |
|                   | 7,605.00   | -56.67               | 11.63           | -52.43                 | 5.67 | V   | -46.47     | 66.54 |
|                   | 10,140.00  | -66.75               | 10.94           | -57.71                 | 6.66 | V   | -53.43     | 73.50 |
|                   | 12,675.00  | -55.79               | 13.85           | -51.88                 | 7.44 | V   | -45.47     | 65.54 |
|                   | 15,210.00  | -52.52               | 14.41           | -51.48                 | 8.61 | H   | -45.68     | 65.75 |
| 21400<br>(2565.0) | 5,130.00   | -50.65               | 12.76           | -56.73                 | 4.52 | V   | -48.49     | 68.56 |
|                   | 7,695.00   | -61.98               | 11.56           | -57.44                 | 5.76 | V   | -51.64     | 71.71 |
|                   | 10,260.00  | -65.48               | 10.87           | -56.76                 | 6.74 | H   | -52.63     | 72.70 |
|                   | 12,825.00  | -57.13               | 13.67           | -52.61                 | 7.44 | V   | -46.38     | 66.45 |
|                   | 15,390.00  | -51.87               | 15.38           | -51.31                 | 8.59 | H   | -44.52     | 64.59 |

- NOTES:**
1. Radiated Spurious Emission Measurements at 1 meter and 3 meter by Substitution Method according to ANSI/TIA/EIA-603-D-2010 June 24, 2010:
  2. We performed all frequency to 10<sup>th</sup> harmonics from 30 MHz. Measurements above show only up to 3 maximum emissions noted, or would be lesser if no specific emissions from the EUT are recorded (ie: margin > 20 dB from the applicable limit) and considered that's already beyond the background noise floor.
  3. We have done x, y, z planes in EUT and horizontal and vertical polarization in detecting antenna.
  4. All of RB size has been tested for emissions and EIRP, with the 1RB configuration observed as the worst case
  5. We performed 16QAM and QPSK modulations. The worst case data are reported in the table above.

**8.2.3 RADIATED SPURIOUS EMISSIONS (15 MHz Band 7 LTE)**

- ▣ OPERATING FREQUENCY : 2507.50 MHz
- ▣ MEASURED OUTPUT POWER: 19.98 dBm = 0.100 W
- ▣ MODULATION SIGNAL: 15 MHz QPSK
- ▣ DISTANCE: 3 meters
- ▣ LIMIT:  $55 + 10 \log_{10}(W) =$  44.98 dBc

| Ch                | Freq (MHz) | Measured Level (dBm) | Ant. Gain (dBi) | Substitute Level (dBm) | C.L  | Pol | EIRP (dBm) | dBc   |
|-------------------|------------|----------------------|-----------------|------------------------|------|-----|------------|-------|
| 20825<br>(2507.5) | 5,015.00   | -62.26               | 12.59           | -67.78                 | 4.48 | V   | -59.67     | 79.65 |
|                   | 7,522.50   | -55.98               | 11.70           | -52.88                 | 5.70 | V   | -46.88     | 66.86 |
|                   | 10,030.00  | -66.08               | 11.00           | -55.73                 | 7.01 | H   | -51.74     | 71.72 |
|                   | 12,537.50  | -56.38               | 14.00           | -53.15                 | 7.31 | V   | -46.46     | 66.44 |
|                   | 15,045.00  | -54.60               | 13.53           | -50.85                 | 8.89 | H   | -46.22     | 66.20 |
| 21100<br>(2535.0) | 5,070.00   | -62.71               | 12.67           | -66.91                 | 4.56 | H   | -58.80     | 78.78 |
|                   | 7,605.00   | -57.39               | 11.63           | -53.15                 | 5.67 | V   | -47.19     | 67.17 |
|                   | 10,140.00  | -66.91               | 10.94           | -57.87                 | 6.66 | H   | -53.59     | 73.57 |
|                   | 12,675.00  | -57.01               | 13.85           | -53.10                 | 7.44 | V   | -46.69     | 66.67 |
|                   | 15,210.00  | -53.67               | 14.41           | -52.63                 | 8.61 | H   | -46.83     | 66.81 |
| 21375<br>(2562.5) | 5,125.00   | -60.27               | 12.75           | -66.04                 | 4.51 | V   | -57.80     | 77.78 |
|                   | 7,687.50   | -60.38               | 11.57           | -55.61                 | 5.67 | V   | -49.71     | 69.69 |
|                   | 10,250.00  | -65.85               | 10.88           | -57.07                 | 6.63 | H   | -52.82     | 72.80 |
|                   | 12,812.50  | -58.41               | 13.68           | -53.65                 | 7.46 | V   | -47.43     | 67.41 |
|                   | 15,375.00  | -51.53               | 15.31           | -50.68                 | 8.66 | H   | -44.04     | 64.02 |

- NOTES:**
1. Radiated Spurious Emission Measurements at 1 meter and 3 meter by Substitution Method according to ANSI/TIA/EIA-603-D-2010 June 24, 2010:
  2. We are performed all frequency to 10<sup>th</sup> harmonics from 30 MHz. Measurements above show only up to 3 maximum emissions noted, or would be lesser if no specific emissions from the EUT are recorded (ie: margin > 20 dB from the applicable limit) and considered that's already beyond the background noise floor.
  3. We have done x, y, z planes in EUT and horizontal and vertical polarization in detecting antenna.
  4. All of RB size has been tested for emissions and EIRP, with the 1RB configuration observed as the worst case
  5. We are performed 16QAM and QPSK modulations. The worst case data are reported in the table above.

**8.2.4 RADIATED SPURIOUS EMISSIONS (20 MHz Band 7 LTE)**

- ▣ OPERATING FREQUENCY : 2510.00 MHz
- ▣ MEASURED OUTPUT POWER: 19.98 dBm = 0.099 W
- ▣ MODULATION SIGNAL: 20 MHz QPSK
- ▣ DISTANCE: 3 meters
- ▣ LIMIT:  $55 + 10 \log_{10}(W) =$  44.98 dBc

| Ch                | Freq (MHz) | Measured Level (dBm) | Ant. Gain (dBi) | Substitute Level (dBm) | C.L  | Pol | EIRP (dBm) | dBc   |
|-------------------|------------|----------------------|-----------------|------------------------|------|-----|------------|-------|
| 20850<br>(2510.0) | 5,020.00   | -55.55               | 12.60           | -61.47                 | 4.47 | V   | -53.34     | 73.32 |
|                   | 7,530.00   | -56.01               | 11.69           | -53.11                 | 5.67 | V   | -47.09     | 67.07 |
|                   | 10,040.00  | -65.85               | 11.00           | -55.82                 | 6.58 | V   | -51.40     | 71.38 |
|                   | 12,550.00  | -56.14               | 13.99           | -52.84                 | 7.25 | V   | -46.10     | 66.08 |
|                   | 15,060.00  | -53.79               | 13.60           | -50.23                 | 8.85 | V   | -45.48     | 65.46 |
| 21100<br>(2535.0) | 5,070.00   | -56.46               | 12.67           | -60.66                 | 4.56 | V   | -52.55     | 72.53 |
|                   | 7,605.00   | -56.55               | 11.63           | -52.31                 | 5.67 | H   | -46.35     | 66.33 |
|                   | 10,140.00  | -66.01               | 10.94           | -56.97                 | 6.66 | V   | -52.69     | 72.67 |
|                   | 12,675.00  | -57.22               | 13.85           | -53.31                 | 7.44 | V   | -46.90     | 66.88 |
|                   | 15,210.00  | -53.61               | 14.41           | -52.57                 | 8.61 | H   | -46.77     | 66.75 |
| 21350<br>(2560.0) | 5,120.00   | -56.80               | 12.75           | -62.27                 | 4.50 | V   | -54.02     | 74.00 |
|                   | 7,680.00   | -58.99               | 11.58           | -53.97                 | 5.62 | H   | -48.01     | 67.99 |
|                   | 10,240.00  | -65.55               | 10.88           | -57.01                 | 6.57 | V   | -52.70     | 72.68 |
|                   | 12,800.00  | -59.72               | 13.70           | -54.83                 | 7.44 | V   | -48.57     | 68.55 |
|                   | 15,360.00  | -55.60               | 15.22           | -54.64                 | 8.75 | V   | -48.17     | 68.15 |

- NOTES:**
1. Radiated Spurious Emission Measurements at 1 meter and 3 meter by Substitution Method according to ANSI/TIA/EIA-603-D-2010 June 24, 2010:
  2. We performed all frequency to 10<sup>th</sup> harmonics from 30 MHz. Measurements above show only up to 3 maximum emissions noted, or would be lesser if no specific emissions from the EUT are recorded (ie: margin > 20 dB from the applicable limit) and considered that's already beyond the background noise floor.
  3. We have done x, y, z planes in EUT and horizontal and vertical polarization in detecting antenna.
  4. All of RB size has been tested for emissions and EIRP, with the 1RB configuration observed as the worst case
  5. We performed 16QAM and QPSK modulations. The worst case data are reported in the table above.

### 8.3 OCCUPIED BANDWIDTH

| Band | Band Width | Frequency (MHz) | Modulation | Resource Block Size | Resource Block Offset | Data ( MHz ) |
|------|------------|-----------------|------------|---------------------|-----------------------|--------------|
| 7    | 5 MHz      | 2535.0          | QPSK       | 25                  | 0                     | 4.5071       |
|      |            |                 | 16-QAM     | 25                  | 0                     | 4.4999       |
|      | 10 MHz     |                 | QPSK       | 50                  | 0                     | 8.9760       |
|      |            |                 | 16-QAM     | 50                  | 0                     | 8.9794       |
|      | 15 MHz     |                 | QPSK       | 75                  | 0                     | 13.459       |
|      |            |                 | 16-QAM     | 75                  | 0                     | 13.468       |
|      | 20 MHz     |                 | QPSK       | 100                 | 0                     | 17.969       |
|      |            |                 | 16-QAM     | 100                 | 0                     | 17.955       |

- Plots of the EUT's Occupied Bandwidth are shown Page 28 ~ 31.

### 8.4 CONDUCTED SPURIOUS EMISSIONS

■ FACTORS FOR FREQUENCY

| Frequency Range (GHz) | Factor [dB] |
|-----------------------|-------------|
| 0.03 – 1              | 27.145      |
| 1 – 5                 | 26.960      |
| 5 – 10                | 27.542      |
| 10 – 15               | 28.439      |
| 15 – 20               | 29.144      |
| Above 20              | 30.148      |

**NOTES:**

Factor(dB) = Cable Loss + Attenuator + Power Splitter

| Band | Band Width (MHz) | Frequency (MHz) | Frequency of Maximum Harmonic (GHz) | Factor (dB) | Measurement Maximum Data (dBm) | Result (dBm) | Limit (dBm) |
|------|------------------|-----------------|-------------------------------------|-------------|--------------------------------|--------------|-------------|
| 7    | 5                | 2,502.5         | 3.2857                              | 26.960      | -59.946                        | -32.986      | -25.00      |
|      |                  | 2,535.0         | 3.7079                              | 26.960      | -59.521                        | -32.561      |             |
|      |                  | 2,567.5         | 3.7104                              | 26.960      | -59.391                        | -32.431      |             |
|      | 10               | 2,505.0         | 3.6820                              | 26.960      | -59.525                        | -32.565      |             |
|      |                  | 2,535.0         | 3.6760                              | 26.960      | -59.210                        | -32.250      |             |
|      |                  | 2,565.0         | 3.6740                              | 26.960      | -59.972                        | -33.012      |             |
|      | 15               | 2,507.5         | 3.7284                              | 26.960      | -60.009                        | -33.049      |             |
|      |                  | 2,535.0         | 2.7050                              | 26.960      | -60.153                        | -33.193      |             |
|      |                  | 2,562.5         | 3.6770                              | 26.960      | -59.827                        | -32.867      |             |
|      | 20               | 2,510.0         | 3.2154                              | 26.960      | -59.689                        | -32.729      |             |
|      |                  | 2,535.0         | 3.7074                              | 26.960      | -59.876                        | -32.916      |             |
|      |                  | 2,560.0         | 3.6815                              | 26.960      | -59.298                        | -32.338      |             |

**NOTES:**

1. Conducted Spurious Emissions was Tested QPSK Modulation, Resource Block Size 1 and Resource Block Offset 0
2. Result (dBm) = Measurement Maximum Data (dBm) + Factor (dB)

- Plots of the EUT's Conducted Spurious Emissions are shown Page 40 ~ 51.

**8.4.1 BAND EDGE**

| Band | Band Width (MHz) | Frequency (MHz) | Modulation | Resource Block Size | Resource Block Offset | Channel Edge ~ -1MHz (Limit : -10 dBm) | -1MHz ~ -4MHz (Limit : -10 dBm) | -4MHz ~ -9.5MHz (Limit : -13 dBm) | -9.5MHz ~ (Limit : -25 dBm) |
|------|------------------|-----------------|------------|---------------------|-----------------------|--|---------------------------------|-----------------------------------|-----------------------------|
|      |                  |                 |            |                     |                       | Lower                                  | Lower                           | Lower                             | Lower                       |
| 7    | 5                | 2502.5          | QPSK       | 25                  | 0                     | -26.95                                 | -22.48                          | -24.79                            | -38.68                      |
|      | 10               | 2505.0          | QPSK       | 50                  | 0                     | -27.71                                 | -23.72                          | -25.34                            | -30.80                      |
|      | 15               | 2507.5          | QPSK       | 75                  | 0                     | -27.93                                 | -24.26                          | -25.50                            | -29.36                      |
|      | 20               | 2510.0          | QPSK       | 100                 | 0                     | -27.86                                 | -24.71                          | -26.59                            | -29.65                      |

| Band | Band Width (MHz) | Frequency (MHz) | Modulation | Resource Block Size | Resource Block Offset | Channel Edge ~±1MHz (Limit : -10 dBm) |        | ±1 MHz ~ ±5 MHz (Limit : -10 dBm) |        | ±5 MHz ~ ±6 MHz (Limit : -13 dBm) |        | ±6 MHz ~ (Limit : -25 dBm) |        |
|------|------------------|-----------------|------------|---------------------|-----------------------|---------------------------------------|--------|-----------------------------------|--------|-----------------------------------|--------|----------------------------|--------|
|      |                  |                 |            |                     |                       | Lower                                 | Upper  | Lower                             | Upper  | Lower                             | Upper  | Lower                      | Upper  |
| 7    | 5                | 2502.5          | QPSK       | 25                  | 0                     | -                                     | -26.55 | -                                 | -22.51 | -                                 | -27.41 | -                          | -28.49 |
|      |                  | 2535.0          | QPSK       | 25                  | 0                     | -27.80                                | -28.21 | -24.65                            | -24.62 | -29.53                            | -29.42 | -30.42                     | -30.49 |
|      |                  | 2567.5          | QPSK       | 25                  | 0                     | -27.78                                | -27.07 | -22.78                            | -22.38 | -26.82                            | -27.48 | -28.68                     | -29.28 |
|      | 10               | 2505.0          | QPSK       | 50                  | 0                     | -                                     | -27.42 | -                                 | -23.03 | -                                 | -23.19 | -                          | -28.95 |
|      |                  | 2535.0          | QPSK       | 50                  | 0                     | -28.53                                | -29.68 | -25.28                            | -26.45 | -25.38                            | -25.49 | -30.40                     | -30.12 |
|      |                  | 2565.0          | QPSK       | 50                  | 0                     | -28.30                                | -28.00 | -24.74                            | -23.16 | -23.48                            | -23.30 | -28.39                     | -29.27 |
|      | 15               | 2507.5          | QPSK       | 75                  | 0                     | -                                     | -27.62 | -                                 | -24.42 | -                                 | -25.21 | -                          | -30.43 |
|      |                  | 2535.0          | QPSK       | 75                  | 0                     | -29.42                                | -30.38 | -25.20                            | -29.43 | -26.50                            | -28.86 | -33.41                     | -32.10 |
|      |                  | 2562.5          | QPSK       | 75                  | 0                     | -28.84                                | -29.82 | -24.90                            | -29.00 | -25.57                            | -28.12 | -31.67                     | -32.17 |
|      | 20               | 2510.0          | QPSK       | 100                 | 0                     | -                                     | -27.50 | -                                 | -24.58 | -                                 | -25.17 | -                          | -31.64 |
|      |                  | 2535.0          | QPSK       | 100                 | 0                     | -28.79                                | -31.44 | -25.66                            | -29.55 | -27.13                            | -27.69 | -33.11                     | -32.00 |
|      |                  | 2560.0          | QPSK       | 100                 | 0                     | -27.01                                | -30.70 | -23.34                            | -29.65 | -24.58                            | -27.75 | -31.41                     | -34.29 |

**NOTES:** Channel Edge was Tested QPSK Modulation and Full RB (Resource Block) Size

- Plots of the EUT's Band Edge are shown Page 32 ~ 39.

## 8.5 REQUENCY STABILITY / VARIATION OF AMBIENT TEMPERATURE

### 8.5.1 FREQUENCY STABILITY (5 MHz Band 7 LTE)

- ▣ OPERATING FREQUENCY: 2,535,000,000 Hz
- ▣ CHANNEL: 21100 (5 MHz)
- ▣ REFERENCE VOLTAGE: 3.85 VDC
- ▣ DEVIATION LIMIT: Emission must remain in band

| Voltage (%)    | Power (VDC) | Temp. (°C) | Frequency (Hz) | Frequency Error (Hz) | Deviation (%) | ppm     |
|----------------|-------------|------------|----------------|----------------------|---------------|---------|
| 100%           | 3.85        | +20(Ref)   | 2534 999 992   | 0.0                  | 0.000 000     | 0.0000  |
| 100%           |             | -30        | 2534 999 989   | -3.5                 | 0.000 000     | -0.0014 |
| 100%           |             | -20        | 2534 999 987   | -5.5                 | 0.000 000     | -0.0022 |
| 100%           |             | -10        | 2534 999 987   | -5.5                 | 0.000 000     | -0.0022 |
| 100%           |             | 0          | 2534 999 981   | -11.0                | 0.000 000     | -0.0043 |
| 100%           |             | +10        | 2534 999 986   | -5.8                 | 0.000 000     | -0.0023 |
| 100%           |             | +30        | 2534 999 986   | -5.8                 | 0.000 000     | -0.0023 |
| 100%           |             | +40        | 2534 999 980   | -11.9                | 0.000 000     | -0.0047 |
| 100%           |             | +50        | 2534 999 984   | -8.3                 | 0.000 000     | -0.0033 |
| Batt. Endpoint | 3.60        | +20        | 2534 999 983   | -9.2                 | 0.000 000     | -0.0036 |

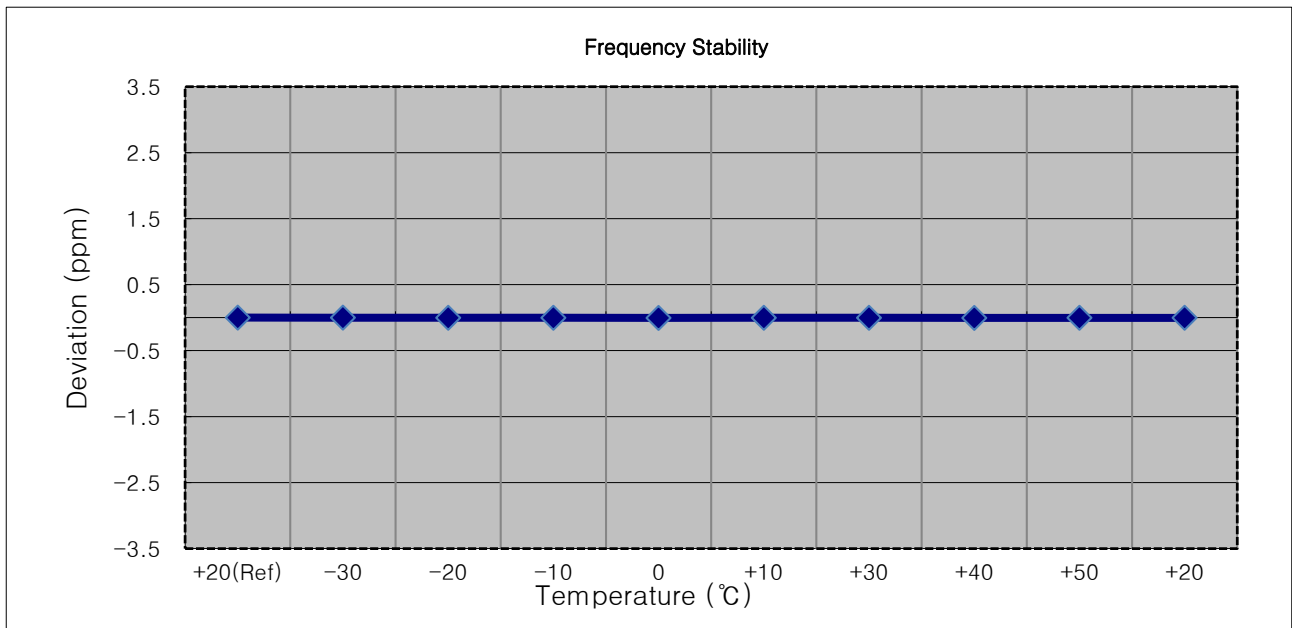

**8.5.2 FREQUENCY STABILITY (10 MHz Band 7 LTE)**

- ▣ OPERATING FREQUENCY: 2,535,000,000 Hz
- ▣ CHANNEL: 21100 (10 MHz)
- ▣ REFERENCE VOLTAGE: 3.85 VDC
- ▣ DEVIATION LIMIT: Emission must remain in band

| Voltage (%)    | Power (VDC) | Temp. (°C) | Frequency (Hz) | Frequency Error (Hz) | Deviation (%) | ppm     |
|----------------|-------------|------------|----------------|----------------------|---------------|---------|
| 100%           | 3.85        | +20(Ref)   | 2534 999 997   | 0.0                  | 0.000 000     | 0.0000  |
| 100%           |             | -30        | 2534 999 993   | -3.7                 | 0.000 000     | -0.0015 |
| 100%           |             | -20        | 2534 999 993   | -4.0                 | 0.000 000     | -0.0016 |
| 100%           |             | -10        | 2534 999 992   | -4.4                 | 0.000 000     | -0.0017 |
| 100%           |             | 0          | 2534 999 992   | -4.9                 | 0.000 000     | -0.0019 |
| 100%           |             | +10        | 2534 999 990   | -7.0                 | 0.000 000     | -0.0028 |
| 100%           |             | +30        | 2534 999 992   | -4.5                 | 0.000 000     | -0.0018 |
| 100%           |             | +40        | 2534 999 991   | -5.2                 | 0.000 000     | -0.0021 |
| 100%           |             | +50        | 2534 999 991   | -5.5                 | 0.000 000     | -0.0022 |
| Batt. Endpoint | 3.60        | +20        | 2534 999 990   | -6.3                 | 0.000 000     | -0.0025 |

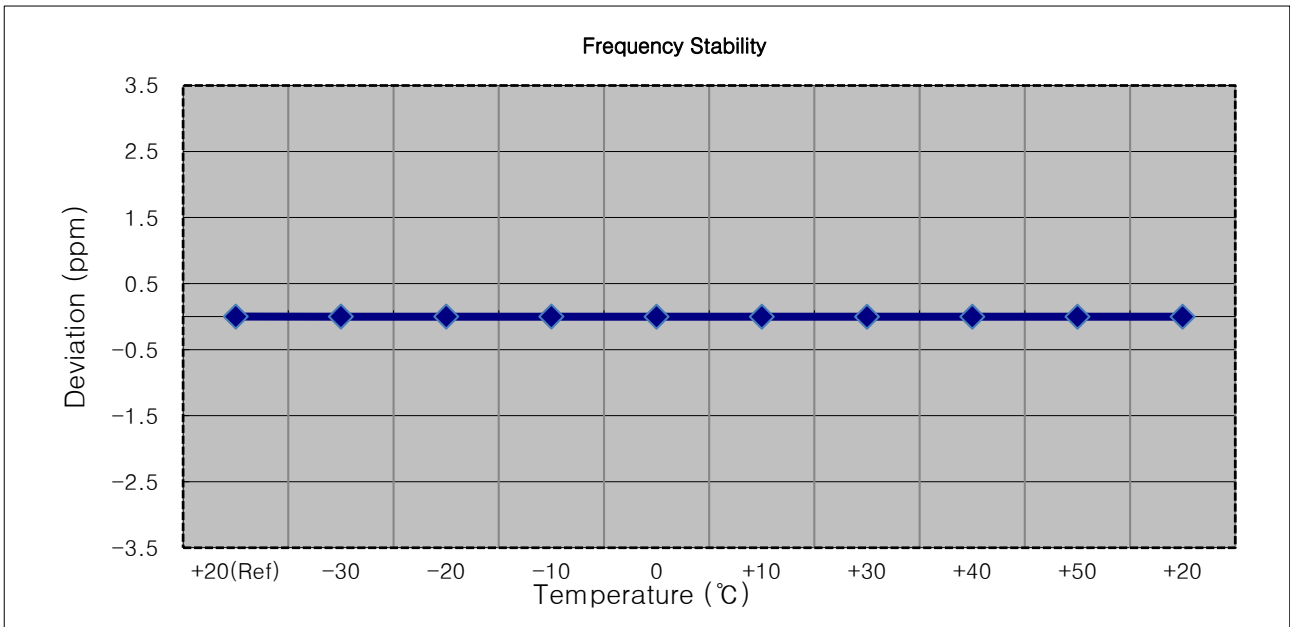



### 8.5.3 FREQUENCY STABILITY (15 MHz Band 7 LTE)

- ▣ OPERATING FREQUENCY: 2,535,000,000 Hz
- ▣ CHANNEL: 21100 (15 MHz)
- ▣ REFERENCE VOLTAGE: 3.85 VDC
- ▣ DEVIATION LIMIT: Emission must remain in band

| Voltage (%)    | Power (VDC) | Temp. (°C) | Frequency (Hz) | Frequency Error (Hz) | Deviation (%) | ppm    |
|----------------|-------------|------------|----------------|----------------------|---------------|--------|
| 100%           | 3.85        | +20(Ref)   | 2534 999 993   | 0.0                  | 0.000 000     | 0.000  |
| 100%           |             | -30        | 2534 999 985   | -7.3                 | 0.000 000     | -0.003 |
| 100%           |             | -20        | 2534 999 986   | -7.0                 | 0.000 000     | -0.003 |
| 100%           |             | -10        | 2534 999 986   | -6.7                 | 0.000 000     | -0.003 |
| 100%           |             | 0          | 2534 999 997   | 4.9                  | 0.000 000     | 0.002  |
| 100%           |             | +10        | 2534 999 988   | -4.4                 | 0.000 000     | -0.002 |
| 100%           |             | +30        | 2534 999 988   | -4.7                 | 0.000 000     | -0.002 |
| 100%           |             | +40        | 2534 999 984   | -8.5                 | 0.000 000     | -0.003 |
| 100%           |             | +50        | 2534 999 989   | -3.3                 | 0.000 000     | -0.001 |
| Batt. Endpoint | 3.60        | +20        | 2534 999 982   | -10.1                | 0.000 000     | -0.004 |

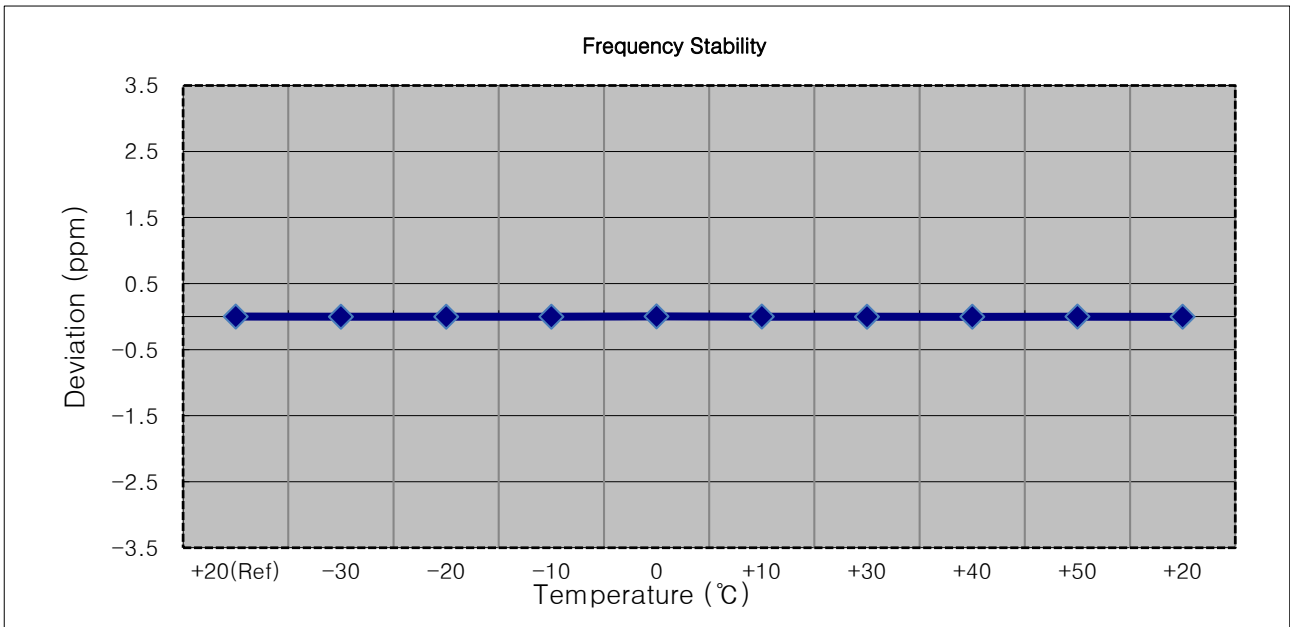

**8.5.4 FREQUENCY STABILITY (20 MHz Band 7 LTE)**

- ▣ OPERATING FREQUENCY: 2,535,000,000 Hz
- ▣ CHANNEL: 21100 (20 MHz)
- ▣ REFERENCE VOLTAGE: 3.85 VDC
- ▣ DEVIATION LIMIT: Emission must remain in band

| Voltage (%)    | Power (VDC) | Temp. (°C) | Frequency (Hz) | Frequency Error (Hz) | Deviation (%) | ppm    |
|----------------|-------------|------------|----------------|----------------------|---------------|--------|
| 100%           | 3.85        | +20(Ref)   | 2534 999 995   | 0.0                  | 0.000 000     | 0.000  |
| 100%           |             | -30        | 2534 999 988   | -7.1                 | 0.000 000     | -0.003 |
| 100%           |             | -20        | 2534 999 986   | -8.7                 | 0.000 000     | -0.003 |
| 100%           |             | -10        | 2534 999 988   | -6.2                 | 0.000 000     | -0.002 |
| 100%           |             | 0          | 2534 999 985   | -9.8                 | 0.000 000     | -0.004 |
| 100%           |             | +10        | 2534 999 988   | -6.9                 | 0.000 000     | -0.003 |
| 100%           |             | +30        | 2534 999 987   | -7.5                 | 0.000 000     | -0.003 |
| 100%           |             | +40        | 2534 999 992   | -3.1                 | 0.000 000     | -0.001 |
| 100%           |             | +50        | 2534 999 988   | -6.2                 | 0.000 000     | -0.002 |
| Batt. Endpoint | 3.60        | +20        | 2534 999 985   | -9.2                 | 0.000 000     | -0.004 |

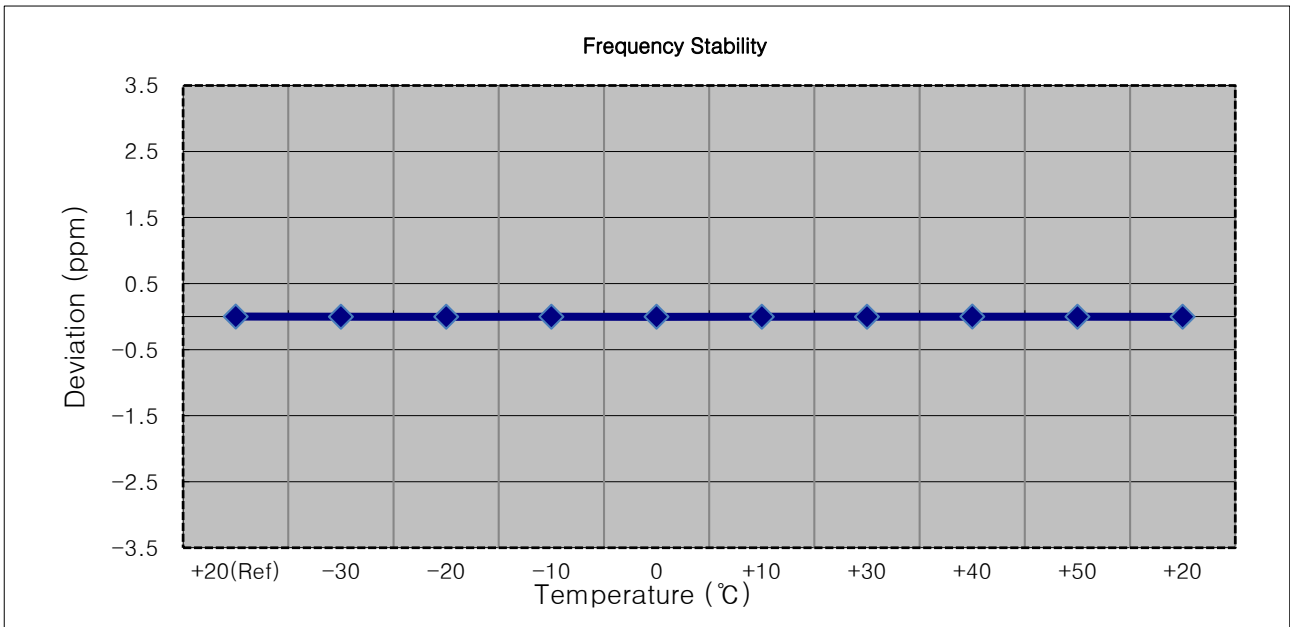

## 9. TEST PLOTS

BAND7. Occupied Bandwidth Plot (5MHz Ch.21100 QPSK RB 25)

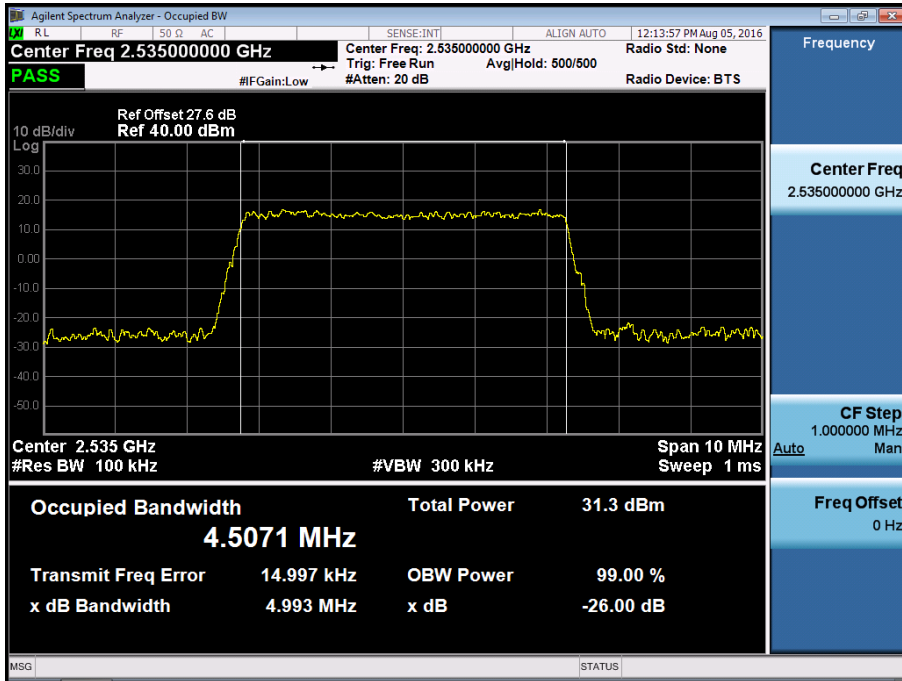

BAND7. Occupied Bandwidth Plot (5MHz Ch.21100 16-QAM RB 25)

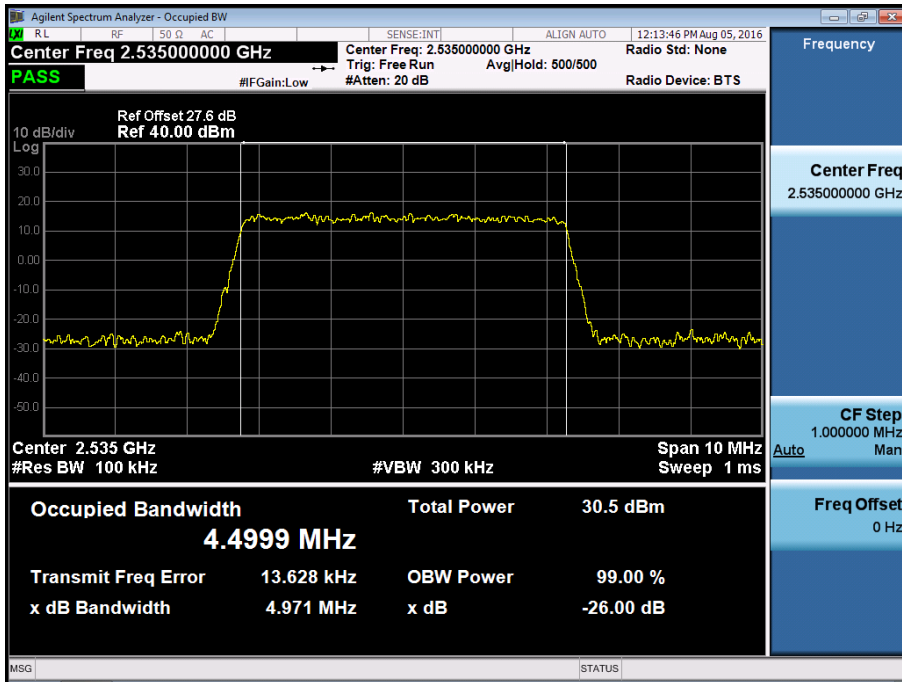

BAND7. Occupied Bandwidth Plot (10MHz Ch.21100 QPSK RB 50)

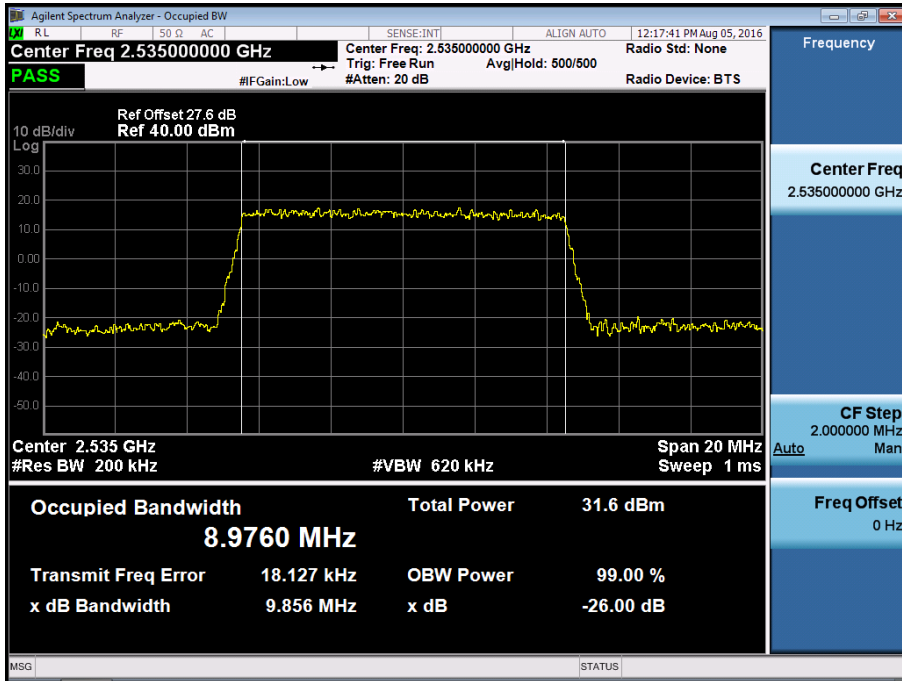

BAND7. Occupied Bandwidth Plot (10MHz Ch.21100 16-QAM RB 50)

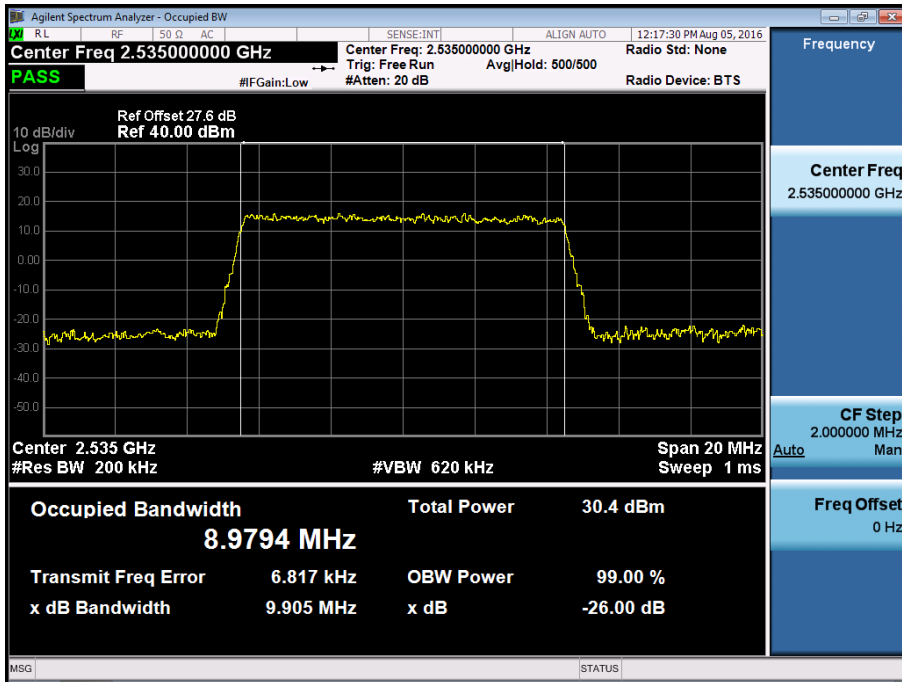

BAND7. Occupied Bandwidth Plot (15MHz Ch.21100 QPSK RB 75)

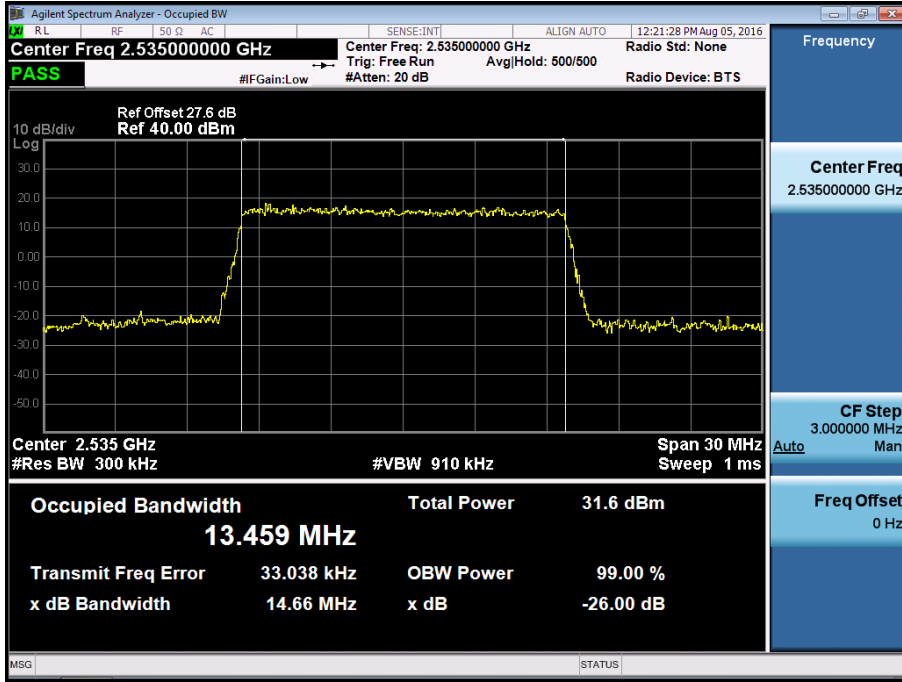

BAND7. Occupied Bandwidth Plot (15MHz Ch.21100 16-QAM RB 75)

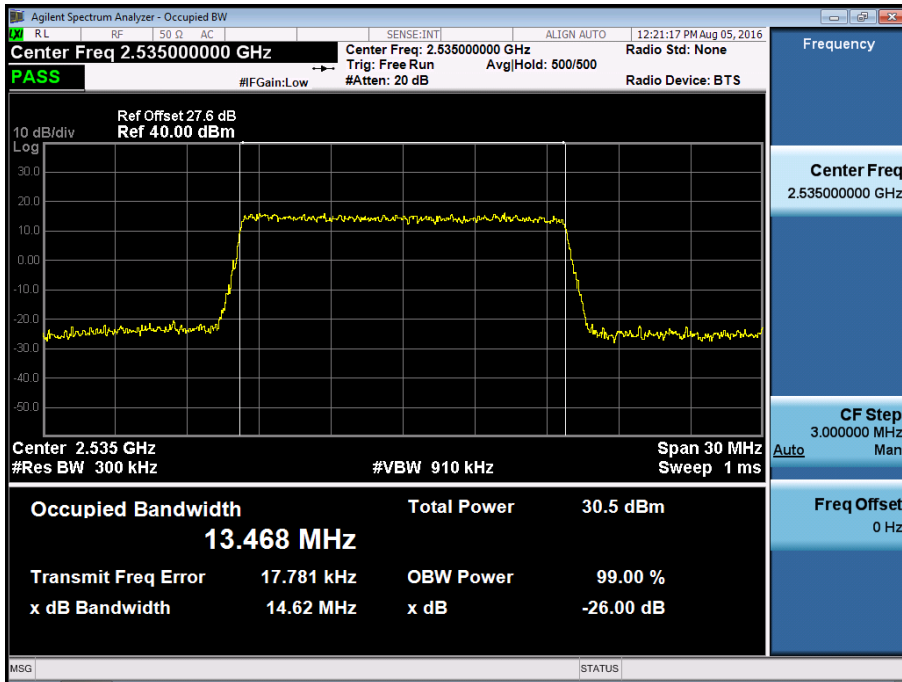

BAND7. Occupied Bandwidth Plot (20MHz Ch.21100 QPSK RB 100)

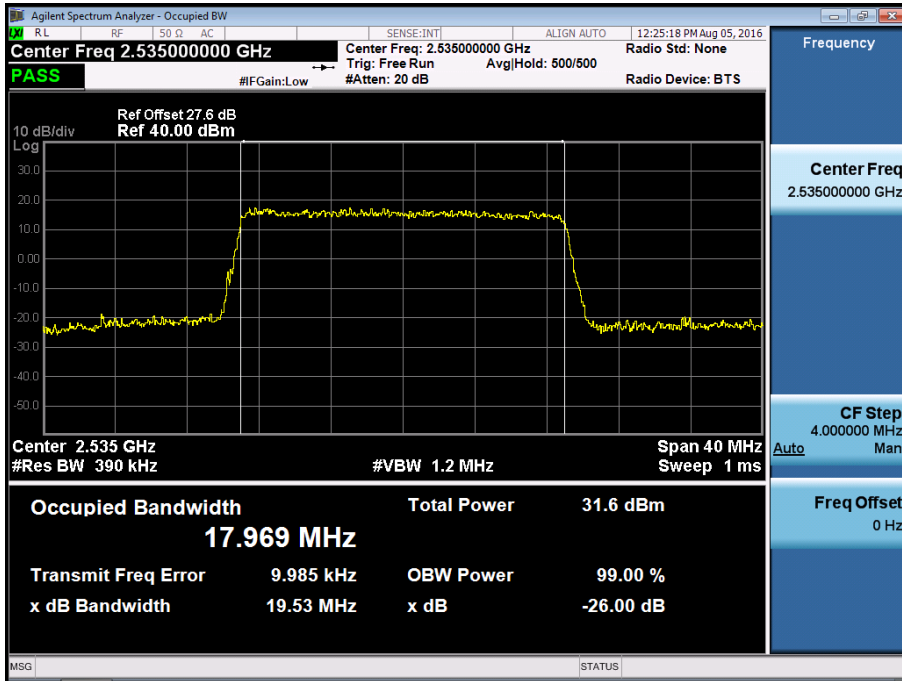

BAND7. Occupied Bandwidth Plot (20MHz Ch.21100 16-QAM RB 100)

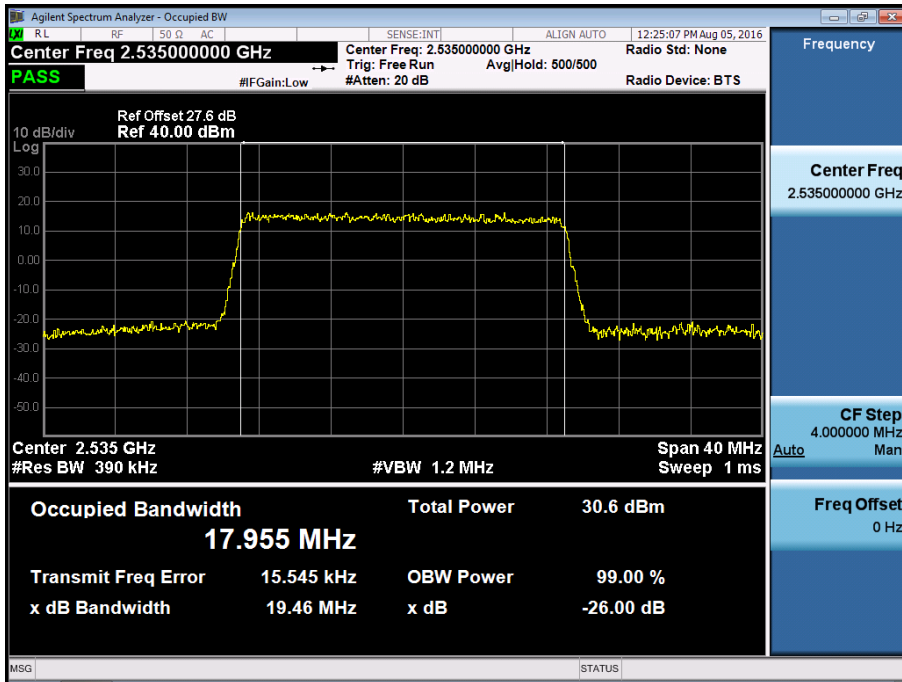

BAND7. Low Channel Edge Plot (5MHz Ch.20775 QPSK RB 25)-1



BAND7. Low Channel Edge Plot (5MHz Ch.20775 QPSK RB 25)-2

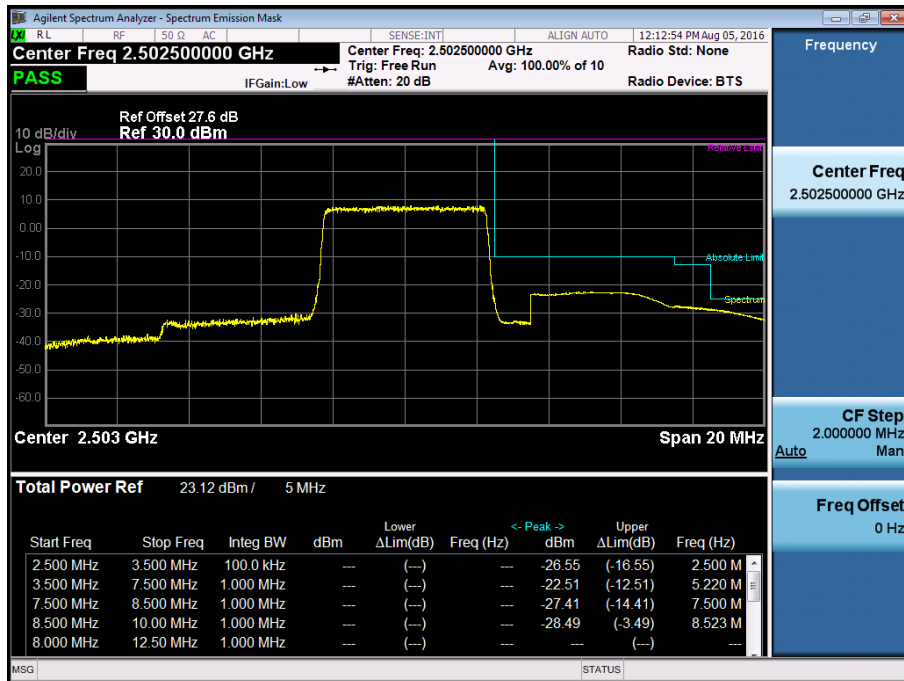



BAND7. Mid Channel Edge Plot (5MHz Ch.21100 QPSK RB 25)

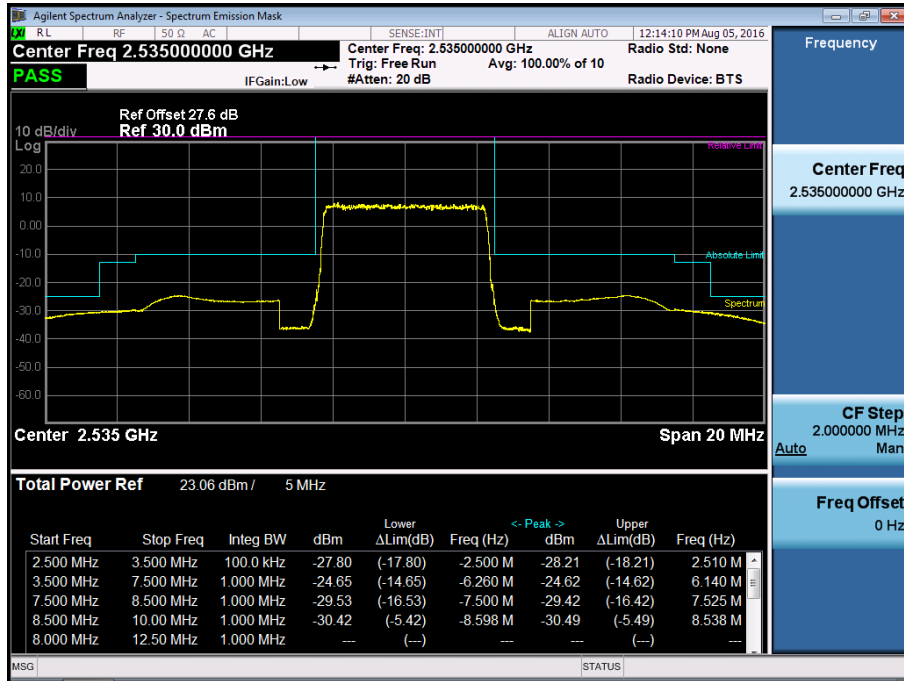

BAND7. High Channel Edge Plot (5MHz Ch.21425 QPSK RB 25)

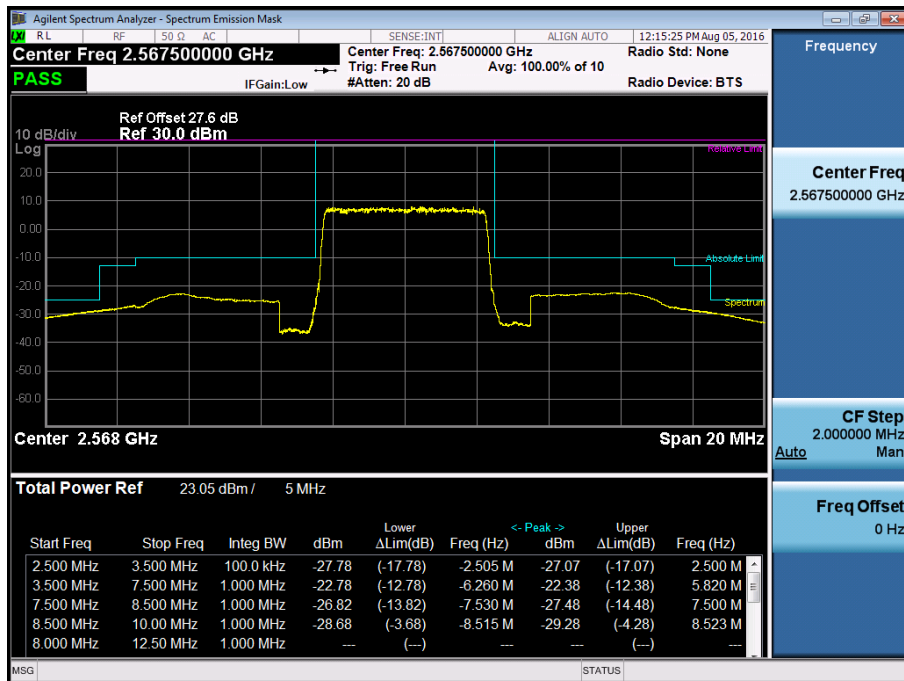

BAND7. Low Channel Edge Plot (10MHz Ch.20800 QPSK RB 50)-1

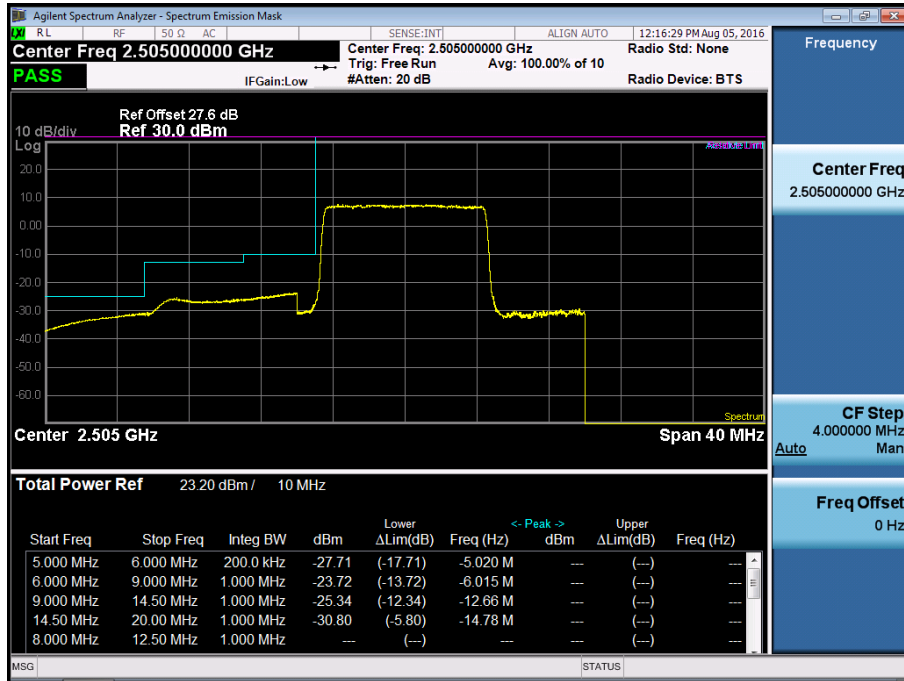

BAND7. Low Channel Edge Plot (10MHz Ch.20800 QPSK RB 50)-2



BAND7. Mid Channel Edge Plot (10MHz Ch.21100 QPSK RB 50)

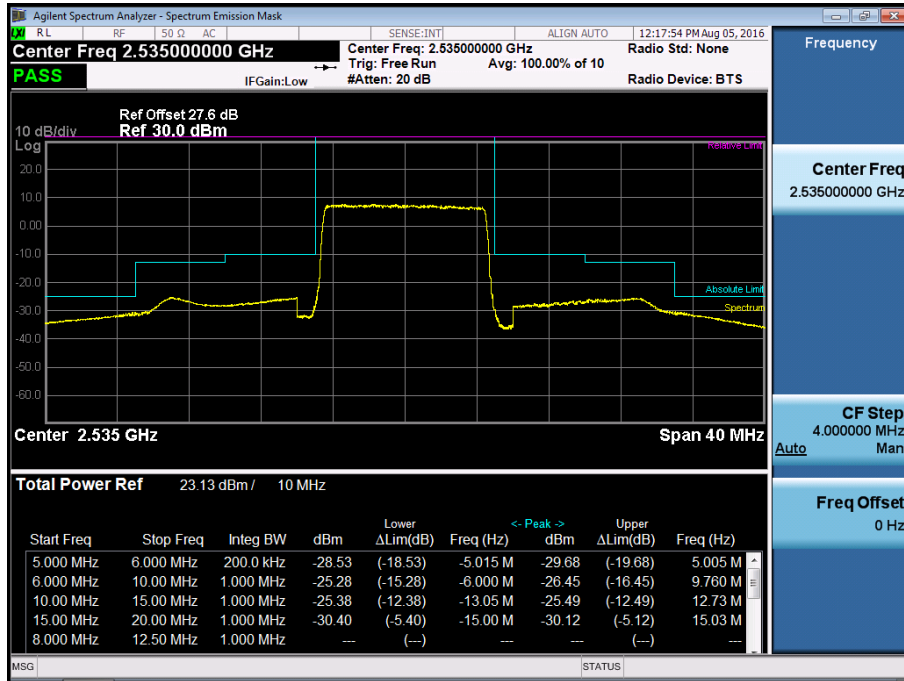

BAND7. High Channel Edge Plot (10MHz Ch.21400 QPSK RB 50)

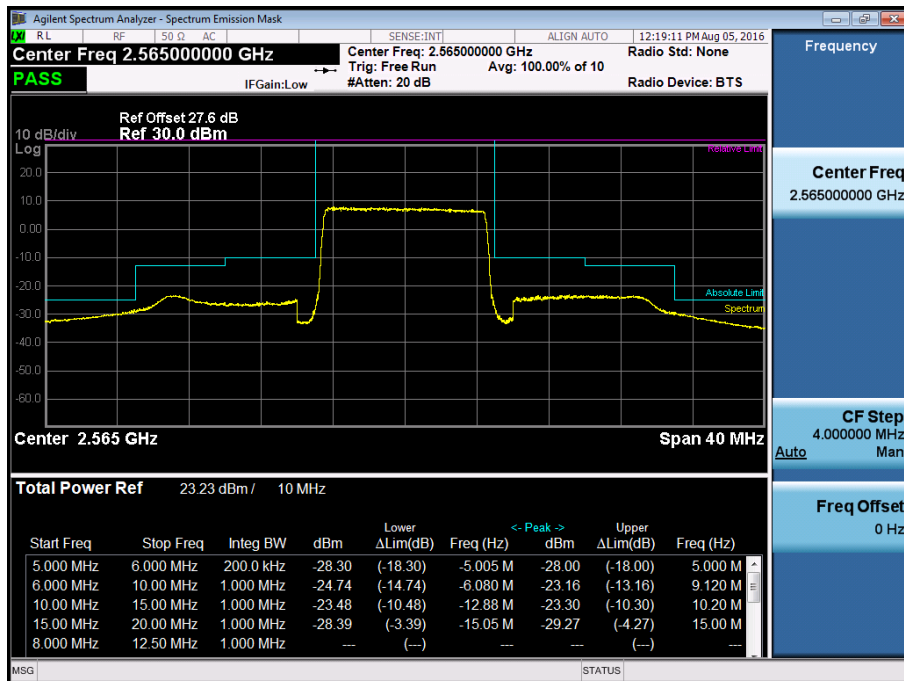

BAND7. Low Channel Edge Plot (15MHz Ch.20825 QPSK RB 75)-1

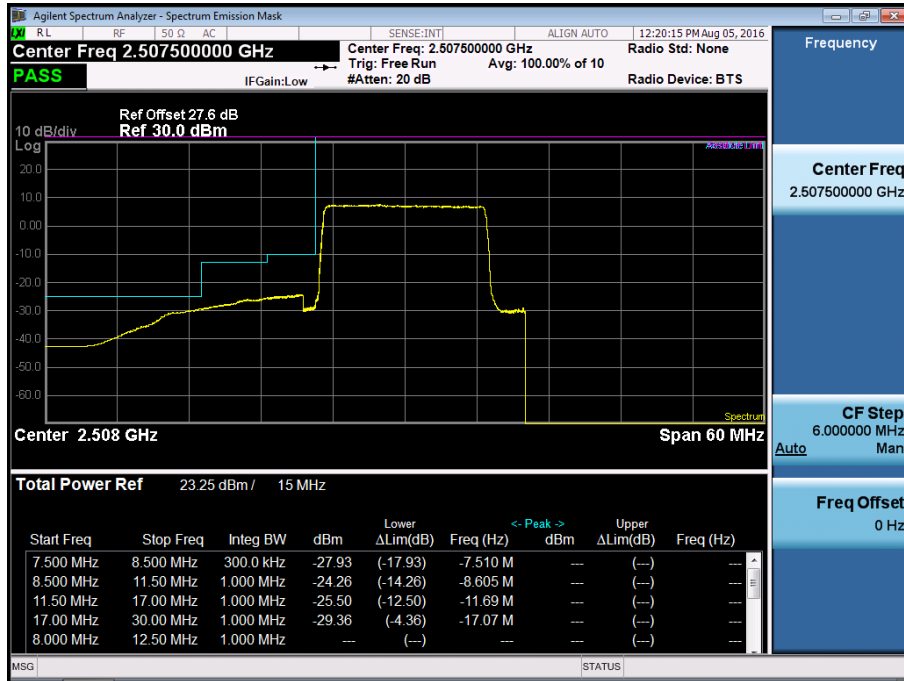

BAND7. Low Channel Edge Plot (15MHz Ch.20825 QPSK RB 75)-2

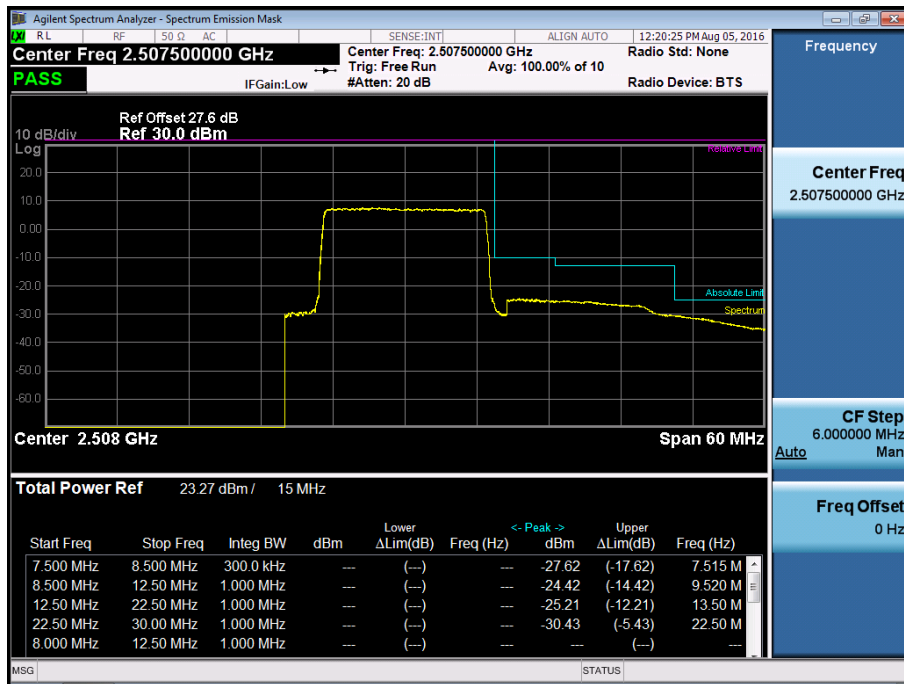

BAND7. Mid Channel Edge Plot (15MHz Ch.21100 QPSK RB 75)

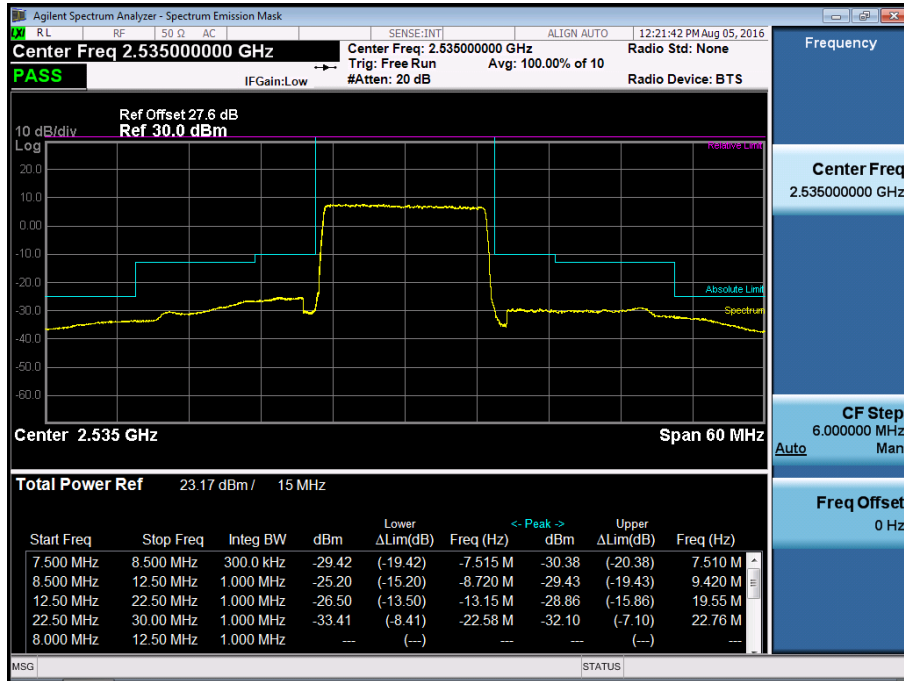

BAND7. High Channel Edge Plot (15MHz Ch.21375 QPSK RB 75)

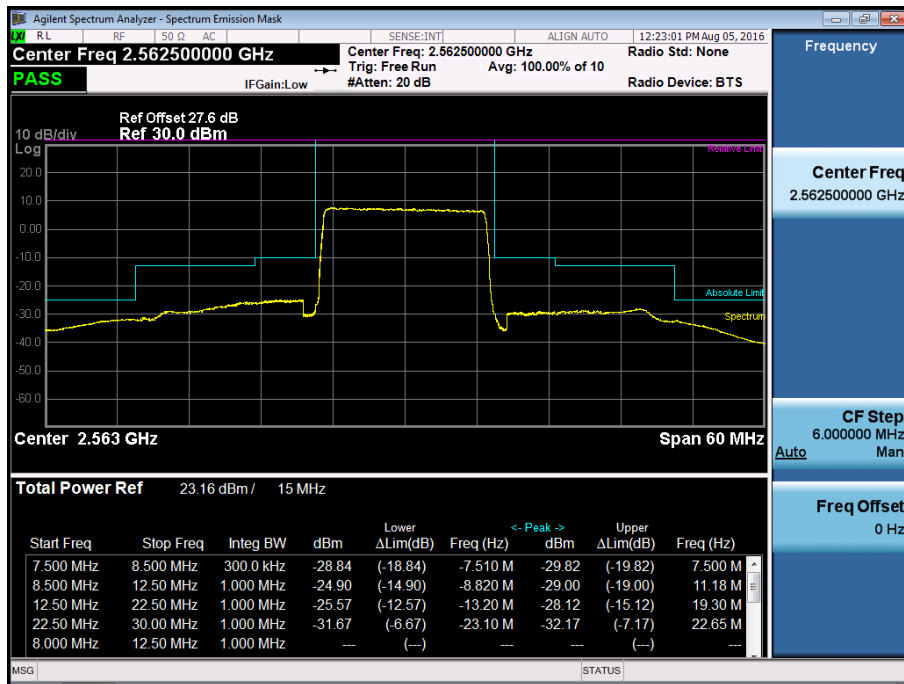

BAND7. Low Channel Edge Plot (20MHz Ch.20850 QPSK RB 100)-1

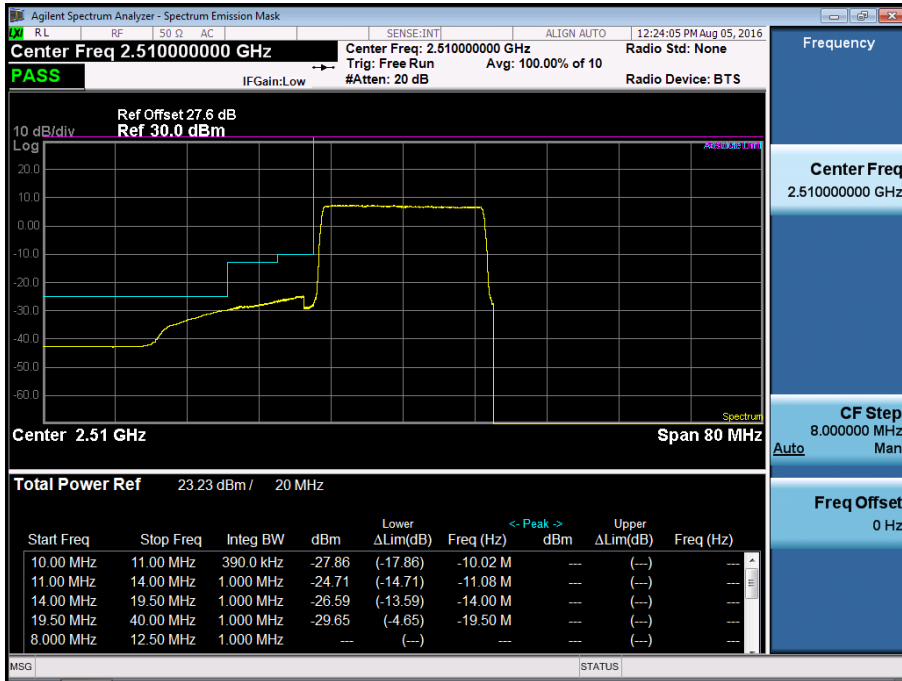

BAND7. Low Channel Edge Plot (20MHz Ch.20850 QPSK RB 100)-2



BAND7. Mid Channel Edge Plot (20MHz Ch.21100 QPSK RB 100)

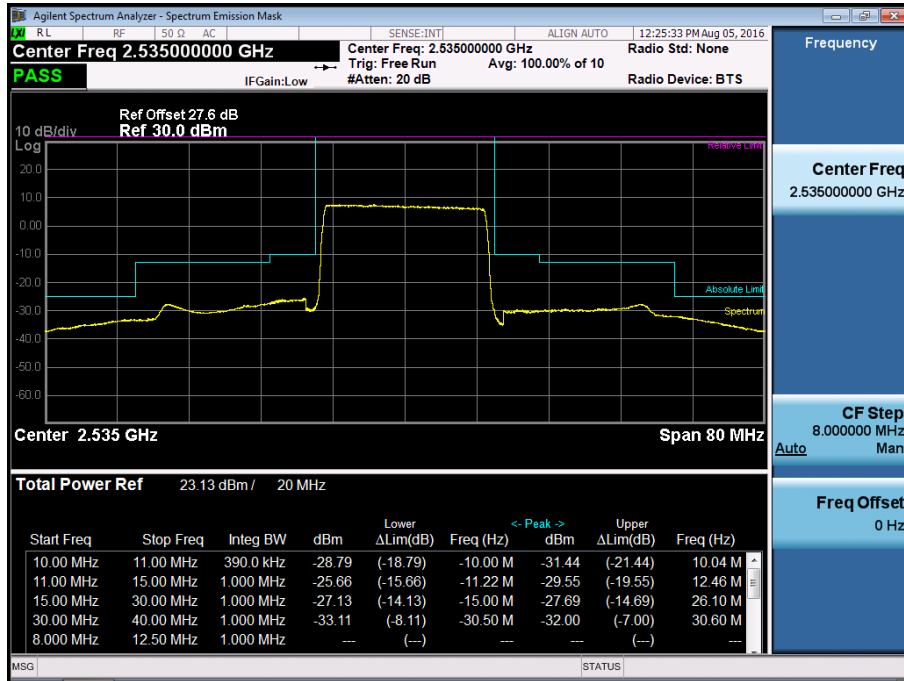

BAND7. High Channel Edge Plot (20MHz Ch.21350 QPSK RB 100)

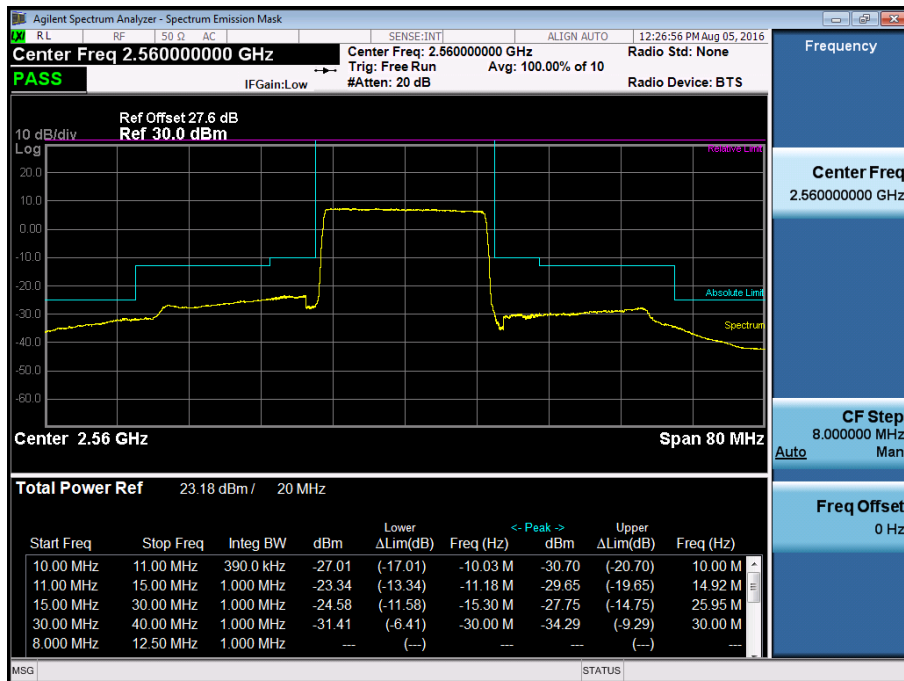

BAND7. Conducted Spurious Plot 1 (5MHz Ch.20775 QPSK RB 1, Offset 0)

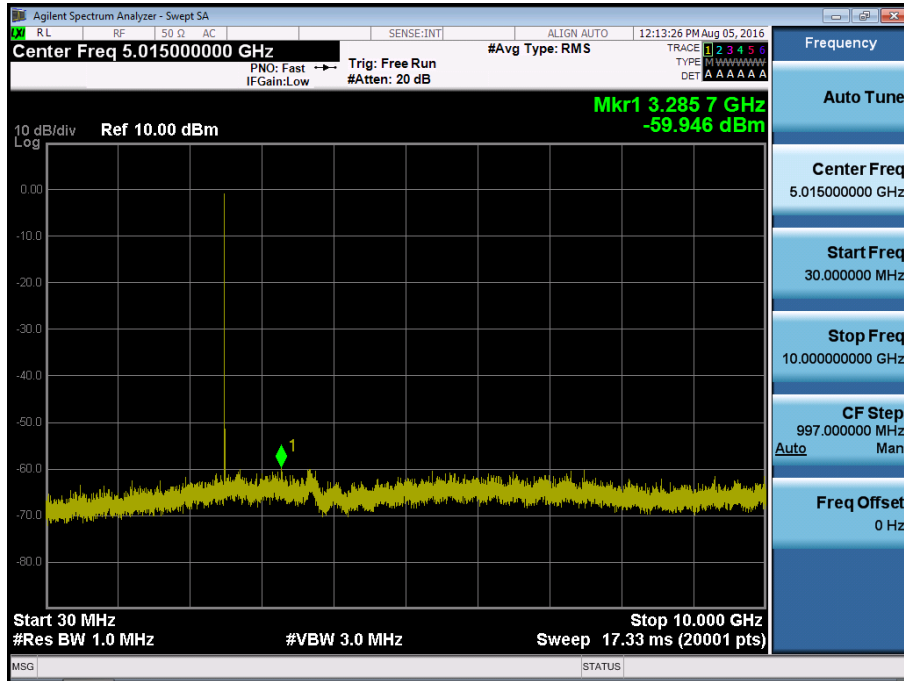

BAND7. Conducted Spurious Plot 2 (5MHz Ch.20775 QPSK RB 1, Offset 0)

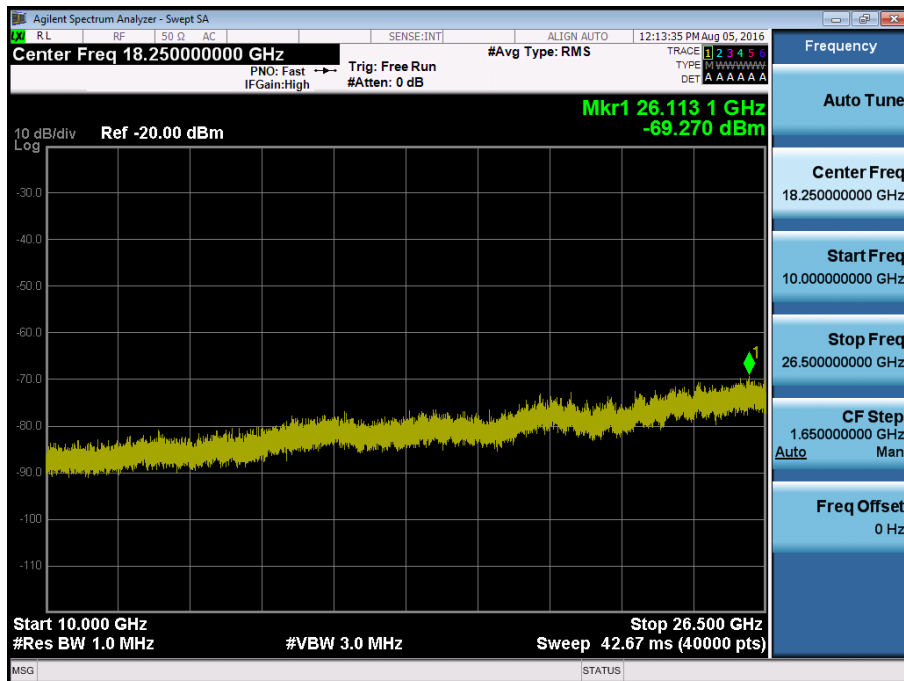



BAND7. Conducted Spurious Plot 1 (5MHz Ch.21100 QPSK RB 1, Offset 0)

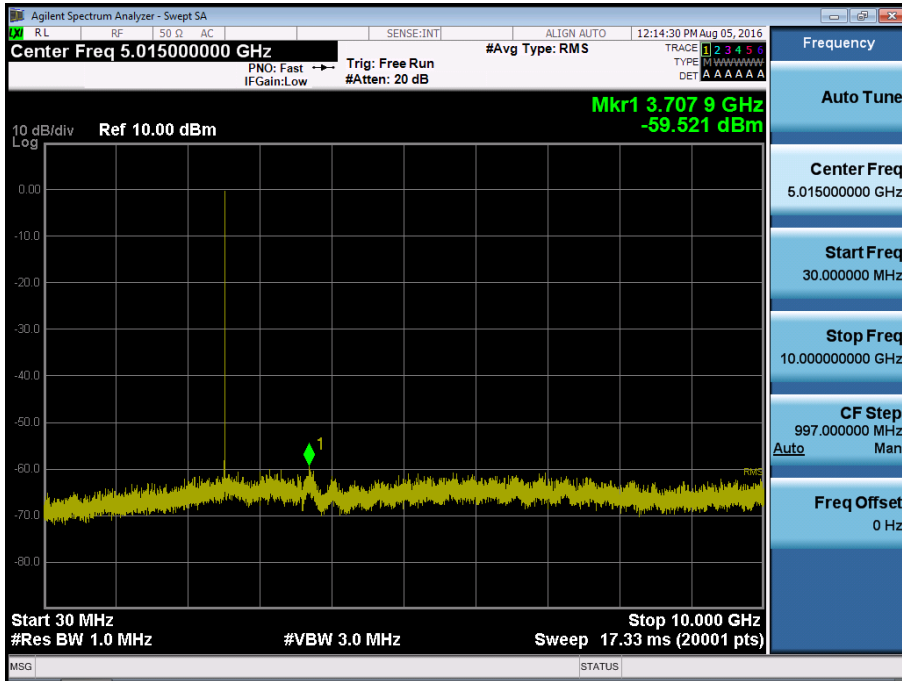

BAND7. Conducted Spurious Plot 2 (5MHz Ch.21100 QPSK RB 1, Offset 0)

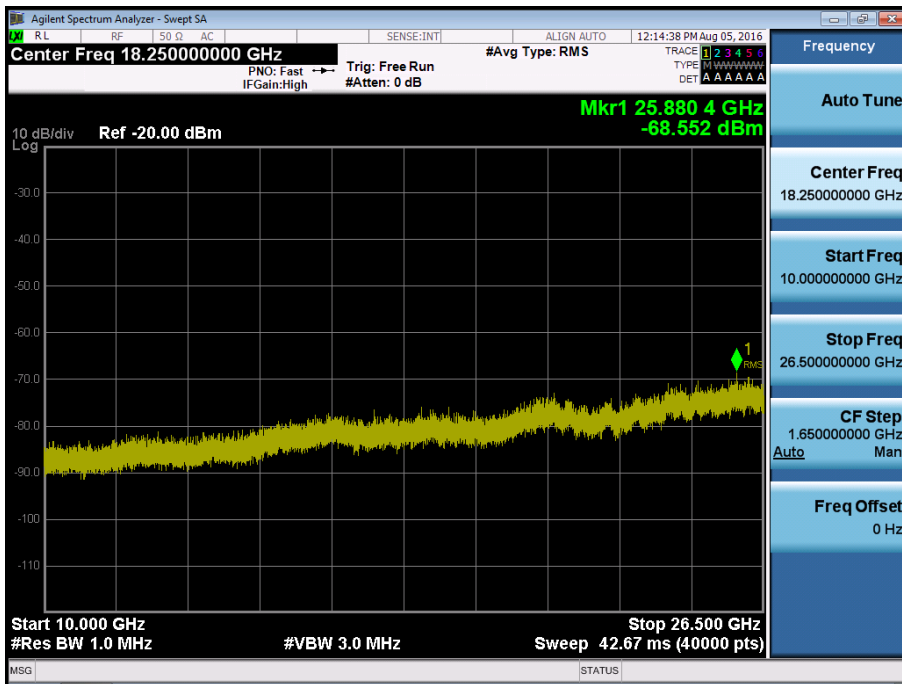

BAND7. Conducted Spurious Plot 1 (5MHz Ch.21425 QPSK RB 1, Offset 0)

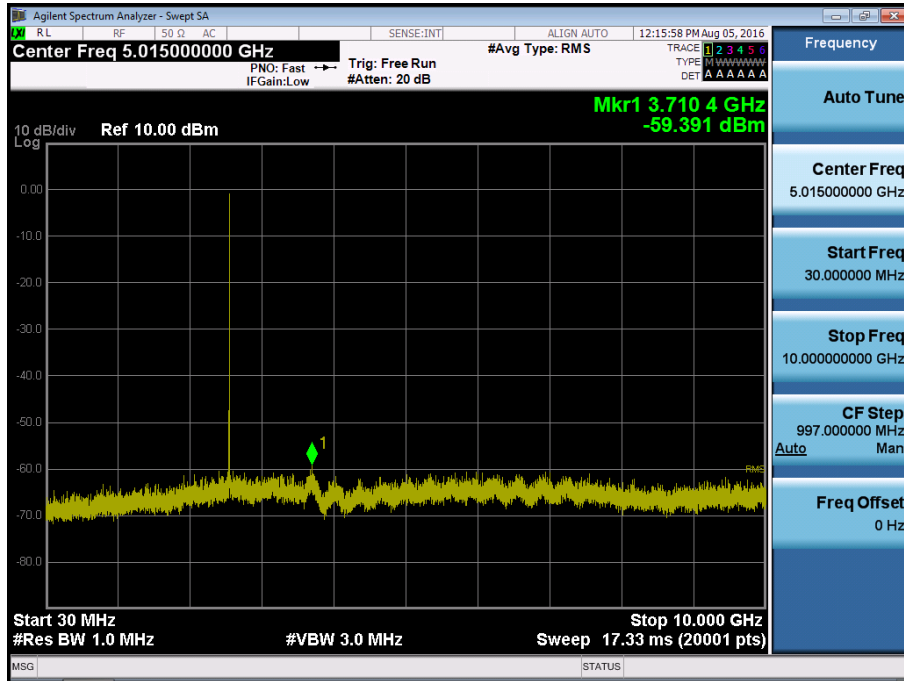

BAND7. Conducted Spurious Plot 2 (5MHz Ch.21425 QPSK RB 1, Offset 0)

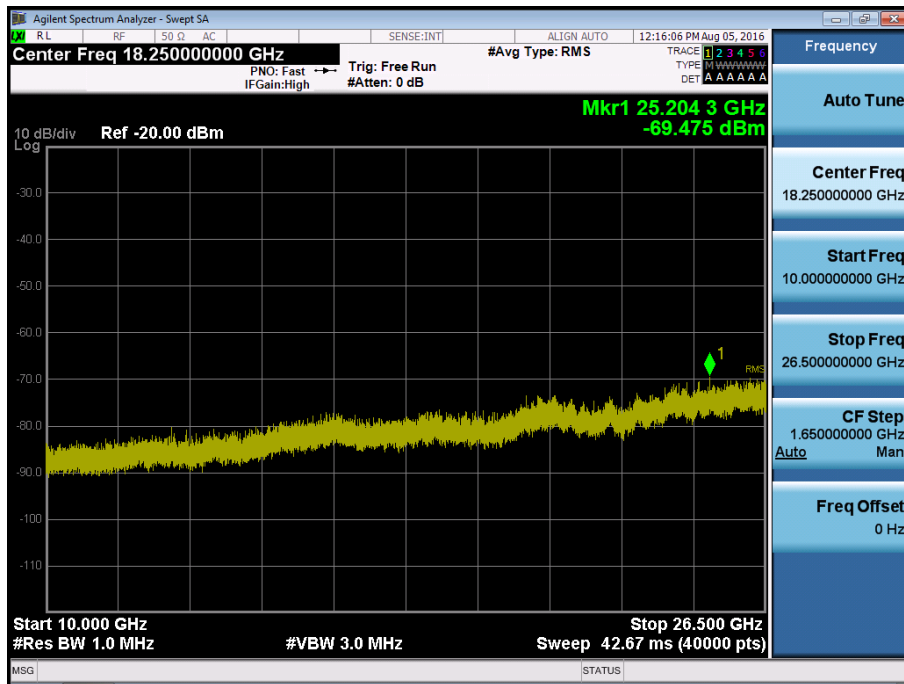

BAND7. Conducted Spurious Plot 1 (10MHz Ch.20800 QPSK RB 1, Offset 0)

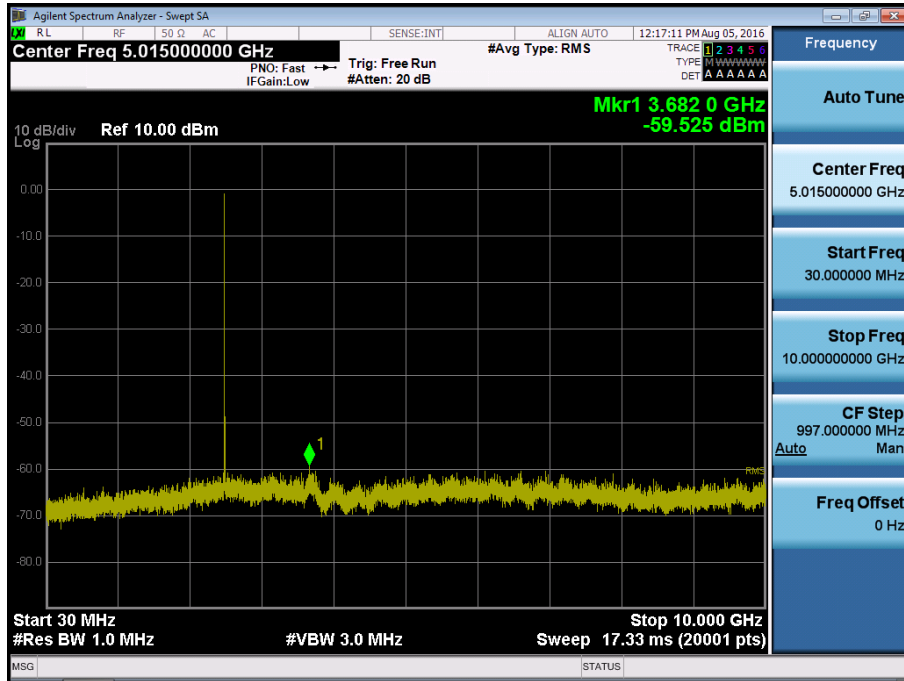

BAND7. Conducted Spurious Plot 2 (10MHz Ch.20800 QPSK RB 1, Offset 0)

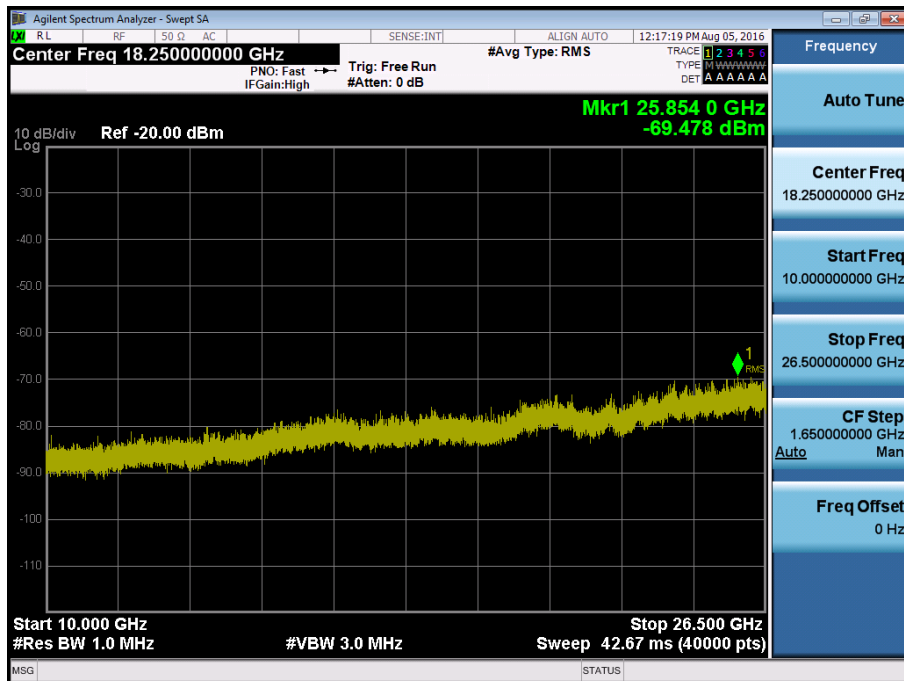

BAND7. Conducted Spurious Plot 1 (10MHz Ch.21100 QPSK RB 1, Offset 0)

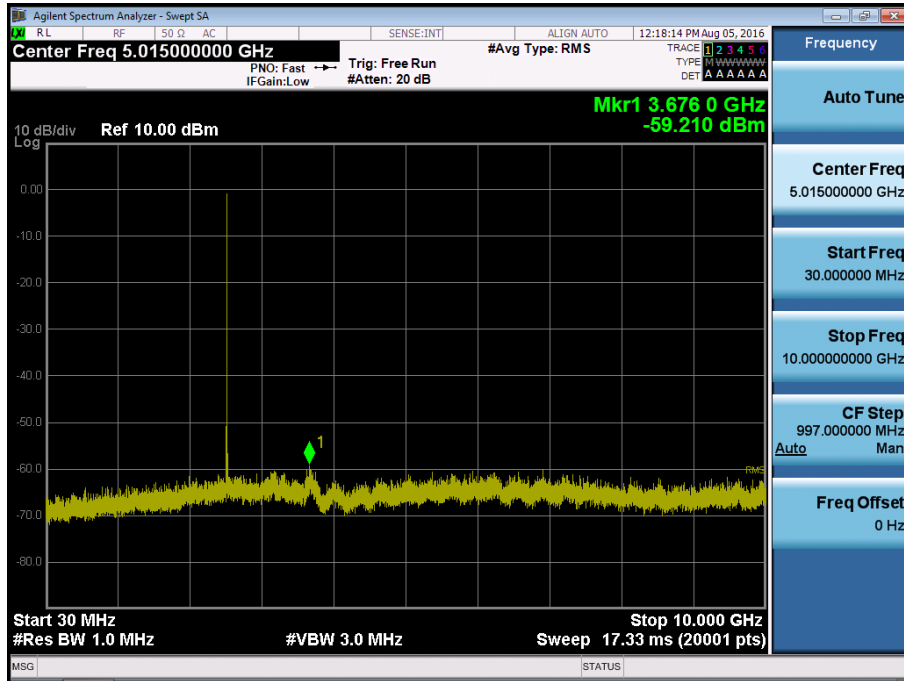

BAND7. Conducted Spurious Plot 2 (10MHz Ch.21100 QPSK RB 1, Offset 0)

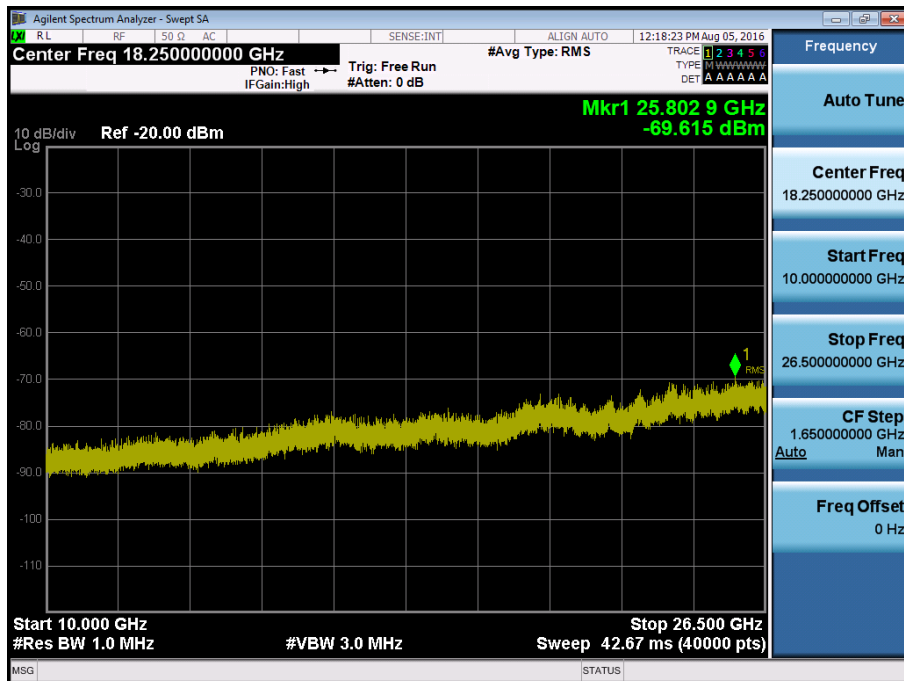

BAND7. Conducted Spurious Plot 1 (10MHz Ch.21400 QPSK RB 1, Offset 0)

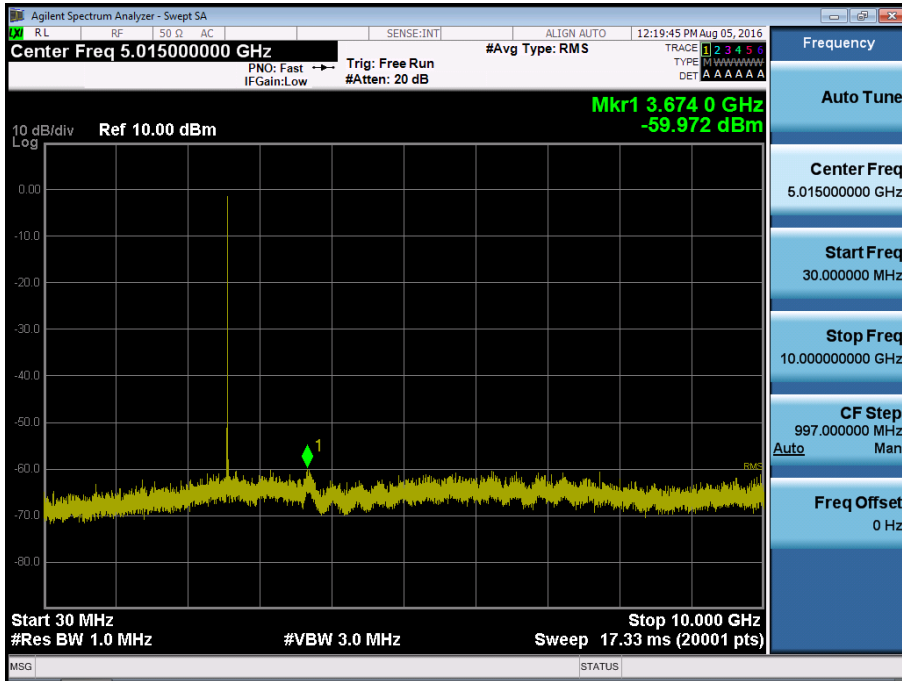

BAND7. Conducted Spurious Plot 2 (10MHz Ch.21400 QPSK RB 1, Offset 0)

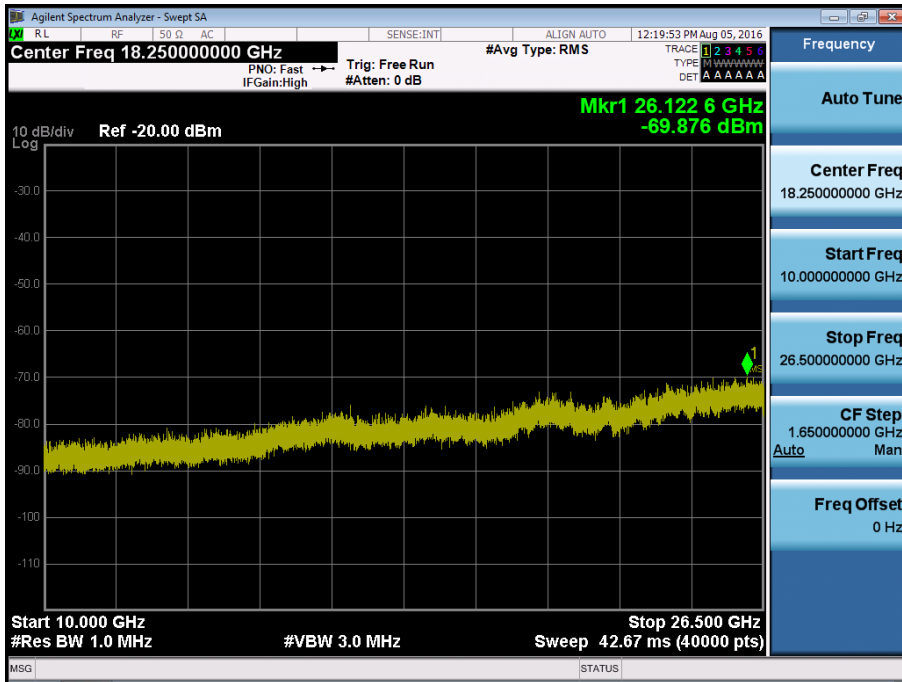

BAND7. Conducted Spurious Plot 1 (15MHz Ch.20825 QPSK RB 1, Offset 0)

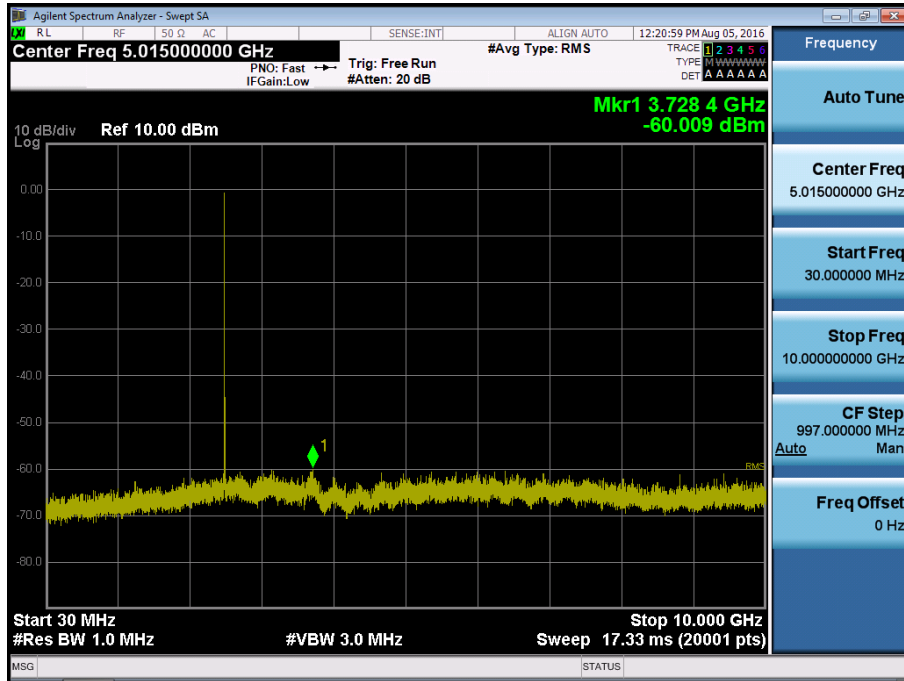

BAND7. Conducted Spurious Plot 2 (15MHz Ch.20825 QPSK RB 1, Offset 0)

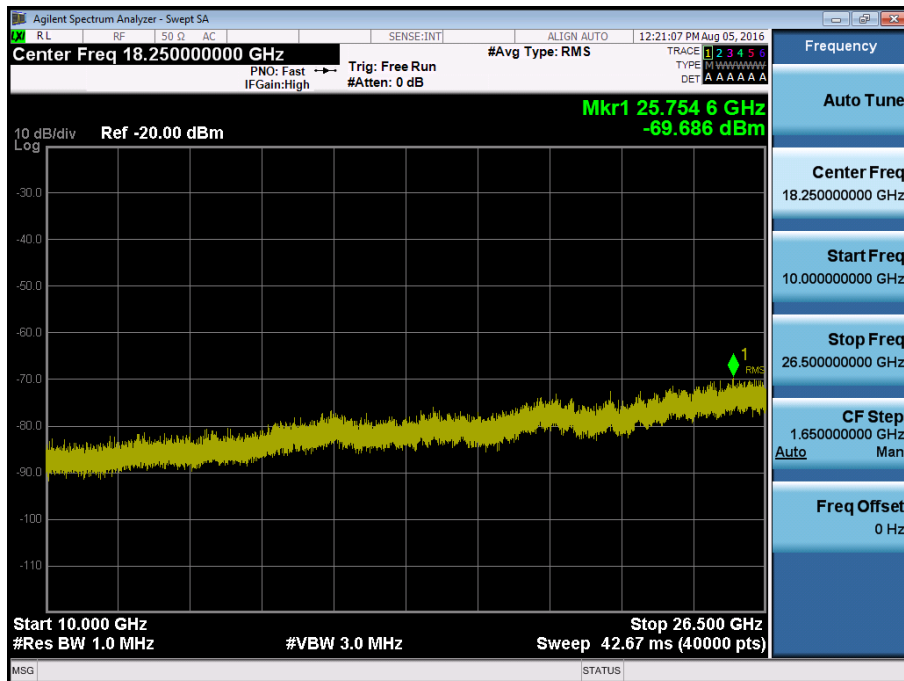

BAND7. Conducted Spurious Plot 1 (15MHz Ch.21100 QPSK RB 1, Offset 0)

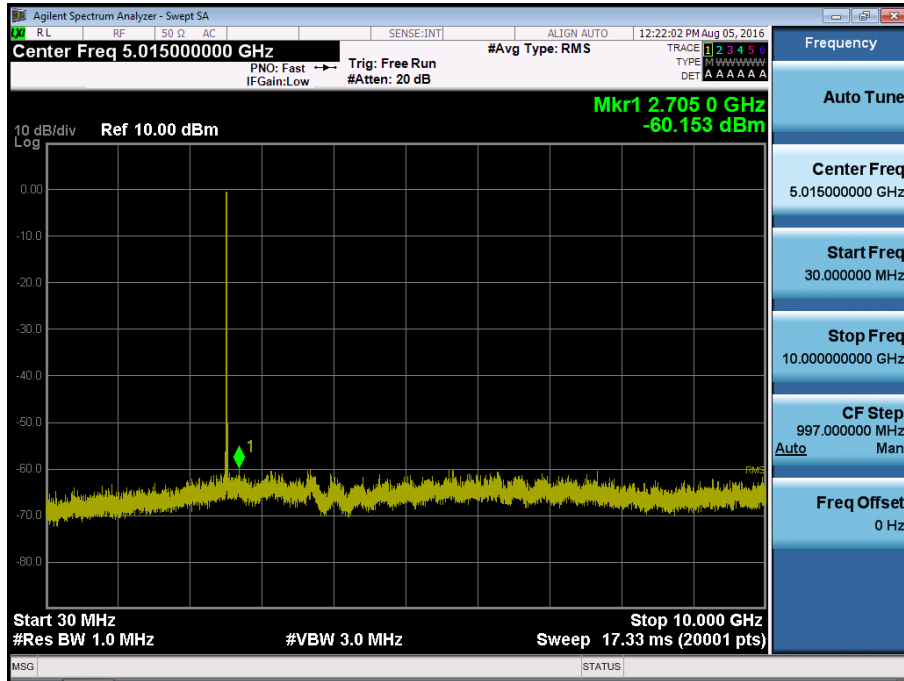

BAND7. Conducted Spurious Plot 2 (15MHz Ch.21100 QPSK RB 1, Offset 0)

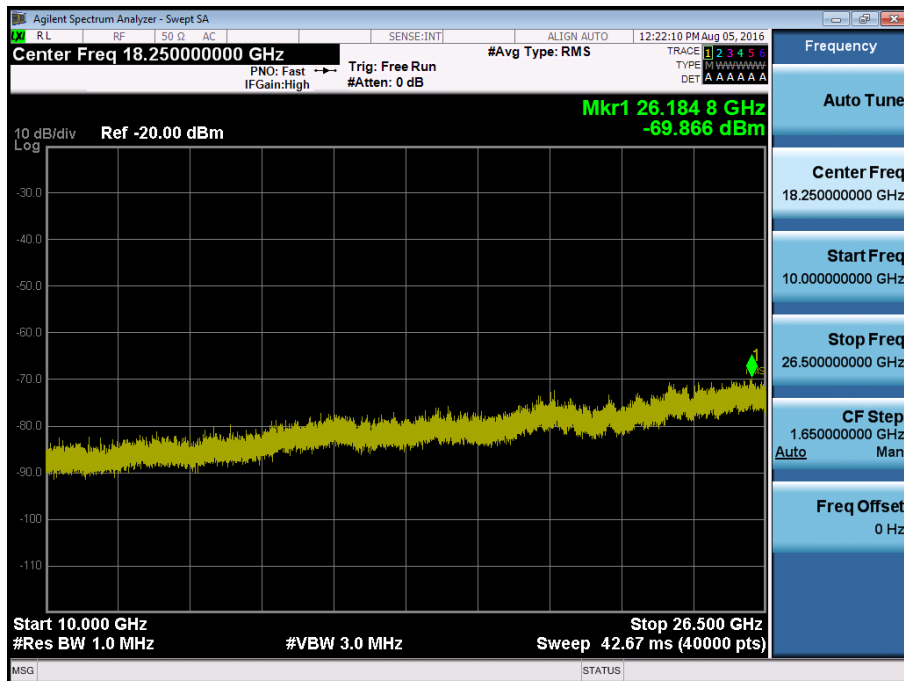

BAND7. Conducted Spurious Plot 1 (15MHz Ch.21375 QPSK RB 1, Offset 0)

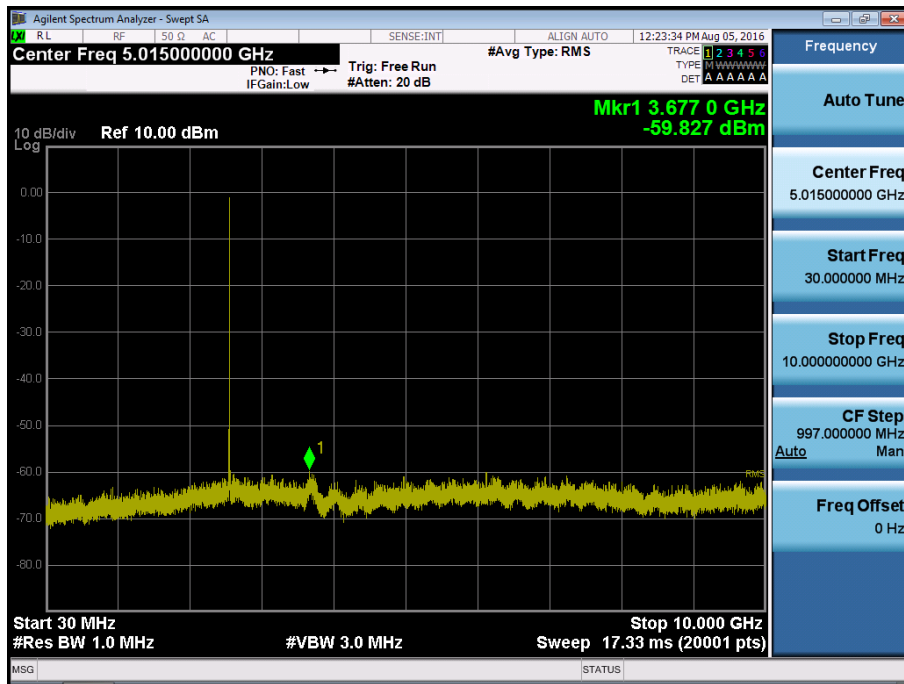

BAND7. Conducted Spurious Plot 2 (15MHz Ch.21375 QPSK RB 1, Offset 0)

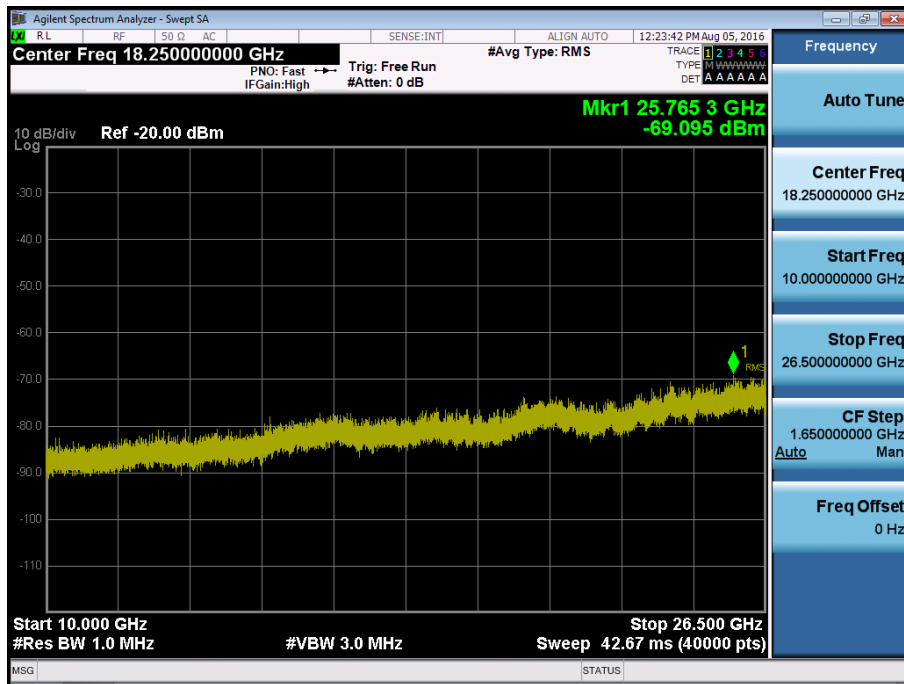



BAND7. Conducted Spurious Plot 1 (20MHz Ch.20850 QPSK RB 1, Offset 0)

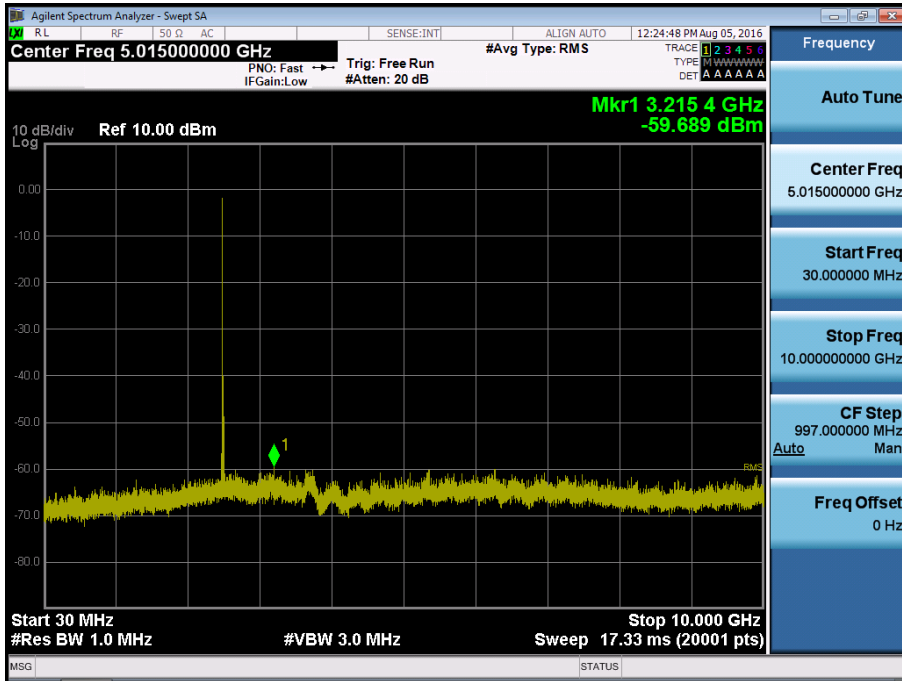

BAND7. Conducted Spurious Plot 2 (20MHz Ch.20850 QPSK RB 1, Offset 0)

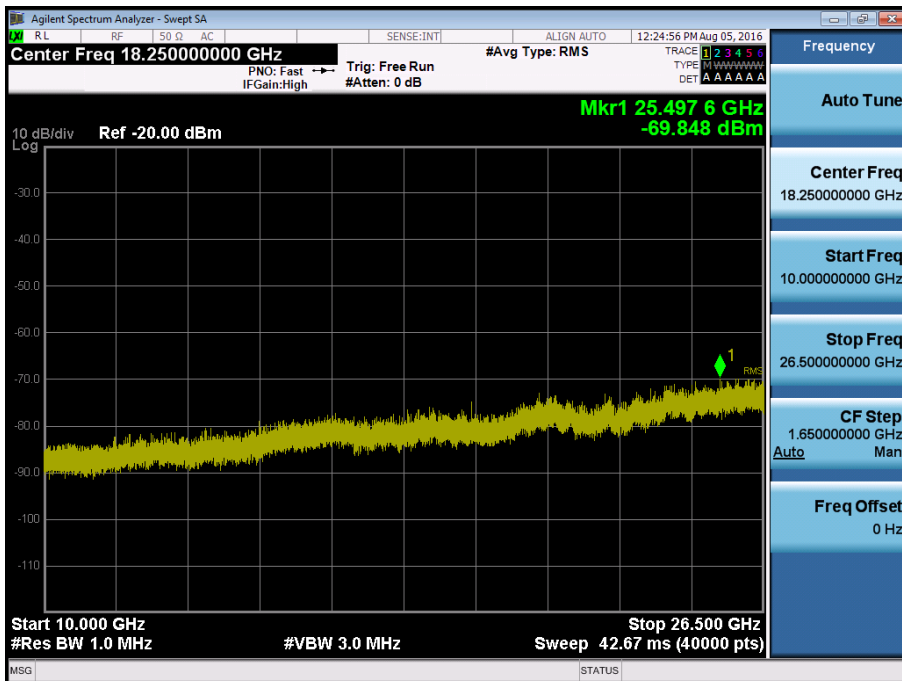

BAND7. Conducted Spurious Plot 1 (20MHz Ch.21100 QPSK RB 1, Offset 0)

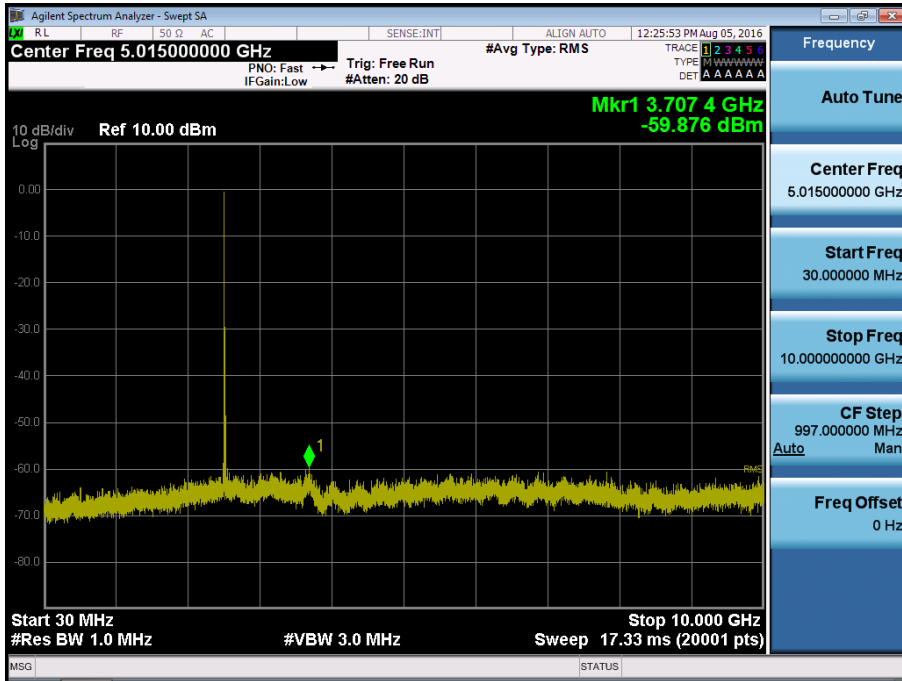

BAND7. Conducted Spurious Plot 2 (20MHz Ch.21100 QPSK RB 1, Offset 0)

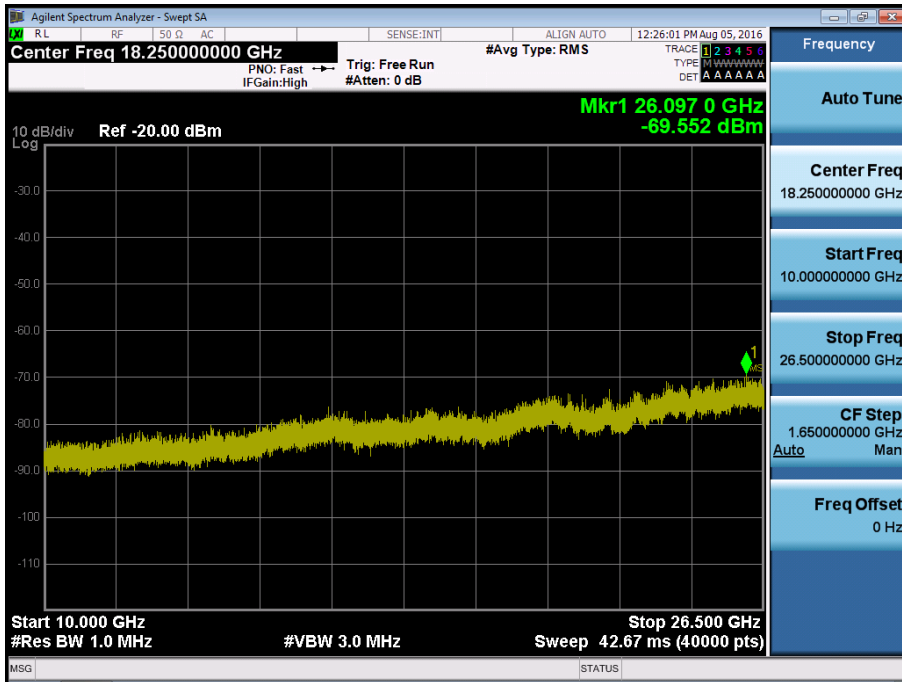

BAND7. Conducted Spurious Plot 1 (20MHz Ch.21350 QPSK RB 1, Offset 0)

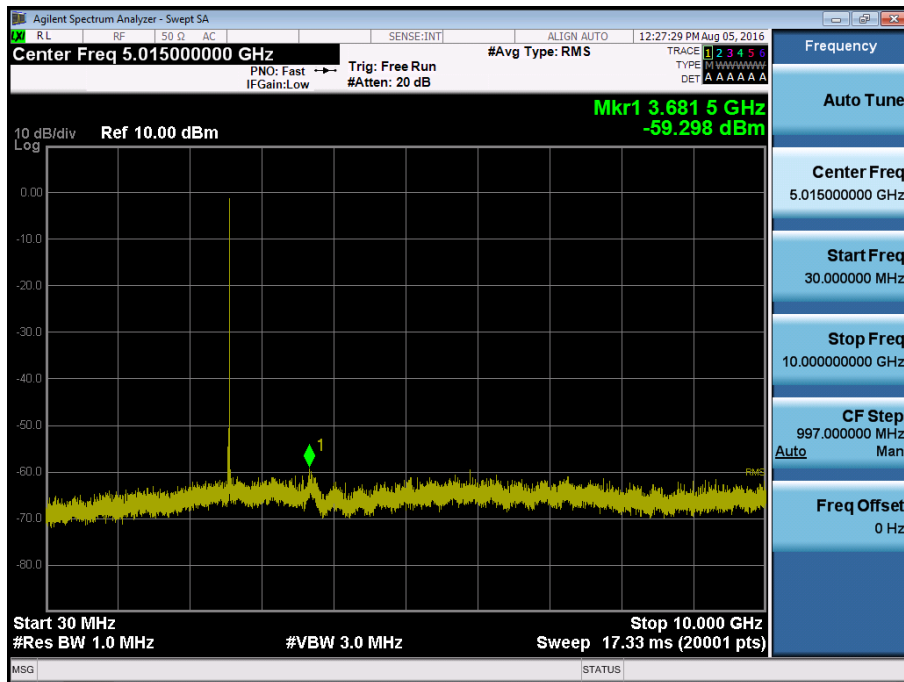

BAND7. Conducted Spurious Plot 2 (20MHz Ch.21350 QPSK RB 1, Offset 0)

