

FCC LTE REPORT

FCC Certification

Applicant Name: LG Electronics MobileComm U.S.A., Inc.	Date of Issue: September 08, 2015
Address: 1000 Sylvan Avenue, Englewood Cliffs NJ 07632	Test Site/Location: HCT CO., LTD., 74, Seoicheon-ro 578beon-gil, Majang-myeon, Icheon-si, Gyeonggi-do, 17383, Rep. of KOREA
	Report No.: HCT-R-1509-F016
	HCT FRN: 0005866421

FCC ID: ZNFH960

APPLICANT: LG Electronics MobileComm U.S.A., Inc.

FCC Model(s): LG-H960

Additional FCC Model(s): LGH960, H960, LG-H960P, LGH960P, H960P, LG-H960AR, LGH960AR, H960AR, LG-H960YK, LGH960YK, H960YK

EUT Type: Cellular/PCS GSM/WCDMA/LTE Phone with WLAN, Bluetooth and NFC

FCC Classification: Licensed Portable Transmitter Held to Ear (PCE)

FCC Rule Part(s): §2 , §27

Standalone with normal cover

Mode (MHz)	Tx Frequency (MHz)	Emission Designator	Modulation	ERP	
				Max. Power (W)	Max. Power (dBm)
LTE – Band12 (1.4)	699.7 – 715.3	1M09G7D	QPSK	0.055	17.41
		1M09W7D	16QAM	0.046	16.63
LTE – Band12 (3)	700.5 – 714.5	2M72G7D	QPSK	0.055	17.41
		2M72W7D	16QAM	0.045	16.54
LTE – Band12 (5)	701.5 – 713.5	4M49G7D	QPSK	0.046	16.65
		4M50W7D	16QAM	0.037	15.69
LTE – Band12 (10)	704.0 – 711.0	8M98G7D	QPSK	0.048	16.80
		8M94W7D	16QAM	0.041	16.14

Standalone with wireless charging cover

Mode (MHz)	Tx Frequency (MHz)	Modulation	ERP	
			Max. Power (W)	Max. Power (dBm)
LTE – Band12 (1.4)	699.7 – 715.3	QPSK	0.054	17.33
		16QAM	0.045	16.50
LTE – Band12 (3)	700.5 – 714.5	QPSK	0.055	17.40
		16QAM	0.045	16.52
LTE – Band12 (5)	701.5 – 713.5	QPSK	0.050	16.98
		16QAM	0.041	16.16
LTE – Band12 (10)	704.0 – 711.0	QPSK	0.046	16.65
		16QAM	0.038	15.83

With wireless charging pad(WCD-110)

Mode (MHz)	Tx Frequency (MHz)	Modulation	ERP	
			Max. Power (W)	Max. Power (dBm)
LTE – Band12 (1.4)	699.7 – 715.3	QPSK	0.045	16.57
		16QAM	0.037	15.69
LTE – Band12 (3)	700.5 – 714.5	QPSK	0.046	16.60
		16QAM	0.035	15.49
LTE – Band12 (5)	701.5 – 713.5	QPSK	0.044	16.43
		16QAM	0.036	15.51
LTE – Band12 (10)	704.0 – 711.0	QPSK	0.045	16.54
		16QAM	0.037	15.69

With wireless charging pad(CT 06801)

Mode (MHz)	Tx Frequency (MHz)	Modulation	ERP	
			Max. Power (W)	Max. Power (dBm)
LTE – Band12 (1.4)	699.7 – 715.3	QPSK	0.042	16.26
		16QAM	0.035	15.43
LTE – Band12 (3)	700.5 – 714.5	QPSK	0.038	15.79
		16QAM	0.030	14.77
LTE – Band12 (5)	701.5 – 713.5	QPSK	0.035	15.49
		16QAM	0.029	14.69
LTE – Band12 (10)	704.0 – 711.0	QPSK	0.032	14.99
		16QAM	0.025	14.02

The measurements shown in this report were made in accordance with the procedures specified in CFR47 section §2.947. I assume full responsibility for the accuracy and completeness of these measurements, and for the qualifications of all persons taking them.

HCT CO., LTD. Certifies that no party to this application has subject to a denial of Federal benefits that includes FCC benefits pursuant to section 5301 of the Anti-Drug Abuse Act of 1998,21 U.S. C.853(a)



Report prepared by
: Jeong Ho Kim
Test engineer of RF Team



Approved by
: Sang Jun Lee
Manager of RF Team

This report only responds to the tested sample and may not be reproduced, except in full, without written approval of the HCT Co., Ltd.

Version

TEST REPORT NO.	DATE	DESCRIPTION
HCT-R-1509-F016	September 08, 2015	- First Approval Report

Table of Contents

1. GENERAL INFORMATION	6
2. INTRODUCTION	8
2.1. EUT DESCRIPTION.....	8
2.2. MEASURING INSTRUMENT CALIBRATION.....	8
2.3. TEST FACILITY	8
3. DESCRIPTION OF TESTS	9
3.1 ERP RADIATED POWER AND RADIATED SPURIOUS EMISSIONS	9
3.2 BLOCK B FREQUENCY RANGE (704 – 710 and 734 – 740 MHz, 777 – 792 MHz)	9
3.3 OCCUPIED BANDWIDTH.	11
3.4 SPURIOUS AND HARMONIC EMISSIONS AT ANTENNA TERMINAL.....	12
3.5 FREQUENCY STABILITY / VARIATION OF AMBIENT TEMPERATURE	13
4. LIST OF TEST EQUIPMENT	14
5. SUMMARY OF TEST RESULTS	15
6. SAMPLE CALCULATION	16
7. TEST DATA	17
7.1 EFFECTIVE RADIATED POWER (Band 12)_Standalone with normal cover	17
7.2 EFFECTIVE RADIATED POWER (Band 12)_Standalone with wireless charging cover	19
7.3 EFFECTIVE RADIATED POWER (Band 12)_With wireless charging pad(WCD-110).....	21
7.4 EFFECTIVE RADIATED POWER (Band 12)_With wireless charging pad(CT 06801).....	23
7.5 RADIATED SPURIOUS EMISSIONS_ Standalone with normal cover	25
7.5.1 RADIATED SPURIOUS EMISSIONS (1.4 MHz Band 12 LTE).....	25
7.5.2 RADIATED SPURIOUS EMISSIONS (3 MHz Band 12 LTE).....	26
7.5.3 RADIATED SPURIOUS EMISSIONS (5 MHz Band 12 LTE).....	27
7.5.4 RADIATED SPURIOUS EMISSIONS (10 MHz Band 12 LTE).....	28
7.6 RADIATED SPURIOUS EMISSIONS_ Standalone with wireless charging cover	29
7.6.1 RADIATED SPURIOUS EMISSIONS (1.4 MHz Band 12 LTE).....	29
7.6.2 RADIATED SPURIOUS EMISSIONS (3 MHz Band 12 LTE).....	30
7.6.3 RADIATED SPURIOUS EMISSIONS (5 MHz Band 12 LTE).....	31
7.6.4 RADIATED SPURIOUS EMISSIONS (10 MHz Band 12 LTE).....	32
7.7 RADIATED SPURIOUS EMISSIONS_With wireless charging pad(WCD-110).....	33
7.7.1 RADIATED SPURIOUS EMISSIONS (1.4 MHz Band 12 LTE).....	33
7.7.2 RADIATED SPURIOUS EMISSIONS (3 MHz Band 12 LTE).....	34
7.7.3 RADIATED SPURIOUS EMISSIONS (5 MHz Band 12 LTE).....	35
7.7.4 RADIATED SPURIOUS EMISSIONS (10 MHz Band 12 LTE).....	36
7.8 RADIATED SPURIOUS EMISSIONS_With wireless charging pad(CT 06801).....	37
7.8.1 RADIATED SPURIOUS EMISSIONS (1.4 MHz Band 12 LTE).....	37

7.8.2 RADIATED SPURIOUS EMISSIONS (3 MHz Band 12 LTE).....	38
7.8.3 RADIATED SPURIOUS EMISSIONS (5 MHz Band 12 LTE).....	39
7.8.4 RADIATED SPURIOUS EMISSIONS (10 MHz Band 12 LTE).....	40
7.9 OCCUPIED BANDWIDTH	41
7.10 CONDUCTED SPURIOUS EMISSIONS	42
7.10.1 BAND EDGE.....	42
7.11 FREQUENCY STABILITY / VARIATION OF AMBIENT TEMPERATURE	43
7.11.1 FREQUENCY STABILITY (1.4 MHz Band 12 LTE)	43
7.11.2 FREQUENCY STABILITY (3 MHz Band 12 LTE).....	44
7.11.3 FREQUENCY STABILITY (5 MHz Band 12 LTE).....	45
7.11.4 FREQUENCY STABILITY (10 MHz Band 12 LTE).....	46
8. TEST PLOTS.....	47

MEASUREMENT REPORT

1. GENERAL INFORMATION

Applicant Name: LG Electronics MobileComm U.S.A., Inc.
Address: 1000 Sylvan Avenue, Englewood Cliffs NJ 07632
FCC ID: ZNFH960
Application Type: Certification
FCC Classification: Licensed Portable Transmitter Held to Ear (PCE)
FCC Rule Part(s): §2 , §27
EUT Type: Cellular/PCS GSM/WCDMA/LTE Phone with WLAN, Bluetooth and NFC
FCC Model(s): LG-H960
Additional FCC Model(s): LGH960, H960, LG-H960P, LGH960P, H960P, LG-H960AR, LGH960AR, H960AR, LG-H960YK, LGH960YK, H960YK
Tx Frequency: 699.7 MHz – 715.3 MHz (LTE – Band12 (1.4 MHz))
700.5 MHz – 714.5 MHz (LTE – Band12 (3 MHz))
701.5 MHz – 713.5 MHz (LTE – Band12 (5 MHz))
704.0 MHz – 711.0 MHz (LTE – Band12 (10 MHz))

Standalone with normal cover

Max. RF Output Power:

Band 12 (1.4 MHz) :	0.055 W (QPSK) (17.41 dBm)
	0.046 W (16-QAM) (16.63 dBm)
Band 12 (3 MHz) :	0.055 W (QPSK) (17.41 dBm)
	0.045 W (16-QAM) (16.54 dBm)
Band 12 (5 MHz) :	0.046 W (QPSK) (16.65 dBm)
	0.037 W (16-QAM) (15.69 dBm)
Band 12 (10 MHz) :	0.048 W (QPSK) (16.80 dBm)
	0.041 W (16-QAM) (16.14 dBm)

Standalone with wireless charging cover

Band 12 (1.4 MHz) :	0.054 W (QPSK) (17.33 dBm)
	0.045 W (16-QAM) (16.50 dBm)
Band 12 (3 MHz) :	0.055 W (QPSK) (17.40 dBm)
	0.045 W (16-QAM) (16.52 dBm)
Band 12 (5 MHz) :	0.050 W (QPSK) (16.98 dBm)
	0.041 W (16-QAM) (16.16 dBm)
Band 12 (10 MHz) :	0.046 W (QPSK) (16.65 dBm)
	0.038 W (16-QAM) (15.83 dBm)

With wireless charging pad(WCD-110)

Band 12 (1.4 MHz) :	0.045 W (QPSK) (16.57 dBm)
	0.037 W (16-QAM) (15.69 dBm)
Band 12 (3 MHz) :	0.046 W (QPSK) (16.60 dBm)
	0.035 W (16-QAM) (15.49 dBm)
Band 12 (5 MHz) :	0.044 W (QPSK) (16.43 dBm)
	0.036 W (16-QAM) (15.51 dBm)
Band 12 (10 MHz) :	0.045 W (QPSK) (16.54 dBm)
	0.037 W (16-QAM) (15.69 dBm)

With wireless charging pad(CT 06801)

Band 12 (1.4 MHz) :	0.042 W (QPSK) (16.26 dBm) 0.035 W (16-QAM) (15.43 dBm)
Band 12 (3 MHz) :	0.038 W (QPSK) (15.79 dBm) 0.030 W (16-QAM) (14.77 dBm)
Band 12 (5 MHz) :	0.035 W (QPSK) (15.49 dBm) 0.029 W (16-QAM) (14.69 dBm)
Band 12 (10 MHz) :	0.032 W (QPSK) (14.99 dBm) 0.025 W (16-QAM) (14.02 dBm)

Emission Designator(s):	Band 12 (1.4 MHz) :	1M09G7D (QPSK) / 1M09W7D (16-QAM)
	Band 12 (3 MHz) :	2M72G7D (QPSK) / 2M72W7D (16-QAM)
	Band 12 (5 MHz) :	4M49G7D (QPSK) / 4M50W7D (16-QAM)
	Band 12 (10 MHz) :	8M98G7D (QPSK) / 8M94W7D (16-QAM)

Date(s) of Tests: July 29, 2015 ~ September 01, 2015

Antenna Specification	Manufacturer:	LS Mtron Co., Ltd.
	Antenna type:	PIFA Antenna (Planar Inverted F)
	Peak Gain:	Band 12: -3.55 dBi

2. INTRODUCTION

2.1. EUT DESCRIPTION

The LG Electronics MobileComm U.S.A., Inc. LG-H960 Cellular/PCS GSM/WCDMA/LTE Phone with WLAN, Bluetooth and NFC consists of LTE 12.

2.2. MEASURING INSTRUMENT CALIBRATION

The measuring equipment, which was utilized in performing the tests documented herein, has been calibrated in accordance with the manufacturer's recommendations for utilizing calibration equipment, which is traceable to recognized national standards.

2.3. TEST FACILITY

The Fully-anechoic chamber and conducted measurement facility used to collect the radiated data are located at the **74, Seoicheon-ro 578beon-gil, Majang-myeon, Icheon-si, Gyeonggi-do, 17383, Rep. of KOREA.**

3. DESCRIPTION OF TESTS

3.1 ERP RADIATED POWER AND RADIATED SPURIOUS EMISSIONS

Note: ERP(Effective Radiated Power)

Test Procedure

Radiated emission measurements are performed in the Fully-anechoic chamber. The equipment under test is placed on a non-conductive table 3-meters away from the receive antenna in accordance with ANSI/TIA-603-D-2010 Clause 2.2.17. The turntable is rotated through 360 degrees, and the receiving antenna scans in order to determine the level of the maximized emission. The level and position of the maximized emission is recorded with the spectrum analyzer using a RMS detector.

A half wave dipole is then substituted in place of the EUT. For emissions above 1GHz, a horn antenna is substituted in place of the EUT. The substitute antenna is driven by a signal generator and the previously recorded signal was duplicated.

The power is calculated by the following formula;

$$P_{d(dBm)} = P_{g(dBm)} - \text{cable loss}_{(dB)} + \text{antenna gain}_{(dB)}$$

Where: P_d is the dipole equivalent power and P_g is the generator output power into the substitution antenna.

Radiated spurious emissions

: Frequency Range : 30 MHz ~ 10th Harmonics of highest channel fundamental frequency.

3.2 BLOCK B FREQUENCY RANGE (704 – 710 and 734 – 740 MHz, 777 – 792 MHz)

§27.5(c)

698-746 MHz Band. The following frequencies are available for licensing pursuant to this part in the 698–746 MHz band: (1) Three paired channel blocks of 12 MHz each are available for assignment as follows :

Block A : 698 – 704 MHz and 728 – 734 MHz ;

Block B : 704 – 710 MHz and 734 – 740 MHz ; and

Block C : 710 – 716 MHz and 740 – 746 MHz.

5.1.1 Peak power measurements with a spectrum/signal analyzer or EMI receiver

The following procedure can be used to determine the total peak output power.

- a) Set the RBW \geq OBW.
- b) Set VBW $\geq 3 \times$ RBW.
- c) Set span $\geq 2 \times$ RBW
- d) Sweep time = auto couple.
- e) Detector = peak.
- f) Ensure that the number of measurement points \geq span/RBW.
- g) Trace mode = max hold.
- h) Allow trace to fully stabilize.
- i) Use the peak marker function to determine the peak amplitude level.

5.2.2 Procedures for use with a spectrum/signal analyzer when EUT cannot be configured to transmit continuously and sweep triggering/signal gating cannot be properly implemented

If the EUT cannot be configured to transmit continuously (burst duty cycle $< 98\%$), then one of the following procedures can be used. The selection of the applicable procedure will depend on the characteristics of the measured burst duty cycle.

Measure the burst duty cycle with a spectrum/signal analyzer or EMC receiver can be used in zero-span mode if the response time and spacing between bins on the sweep are sufficient to permit accurate measurement of the burst on/off time of the transmitted signal.

5.2.2.2 Constant burst duty cycle

If the measured burst duty cycle is constant (i.e., duty cycle variations are less than ± 2 percent), then:

- a) Set span to at least 1.5 times the OBW.
- b) Set RBW = 1-5% of the OBW, not to exceed 1 MHz.
- c) Set VBW $\geq 3 \times$ RBW.
- d) Number of points in sweep $\geq 2 \times$ span / RBW. (This gives bin-to-bin spacing \leq RBW/2, so that narrowband signals are not lost between frequency bins.)
- e) Sweep time = auto.
- f) Detector = RMS (power averaging).
- g) Set sweep trigger to "free run".
- h) Trace average at least 100 traces in power averaging (i.e., RMS) mode.
- i) Compute power by integrating the spectrum across the OBW of the signal using the instrument's band power measurement function with band limits set equal to the OBW band edges. If the instrument does not have a band power function, sum the spectrum levels (in power units) at intervals equal to the RBW extending across the entire OBW of the spectrum.
- j) Add $10 \log (1/x)$, where x is the duty cycle, to the measured power in order to compute the average power during the actual transmission times (because the measurement represents an average over both the on and off times of the transmission).

For example, add $10 \log (1/0.25) = 6$ dB if the duty cycle is a constant 25%.

3.3 OCCUPIED BANDWIDTH.

Test set-up

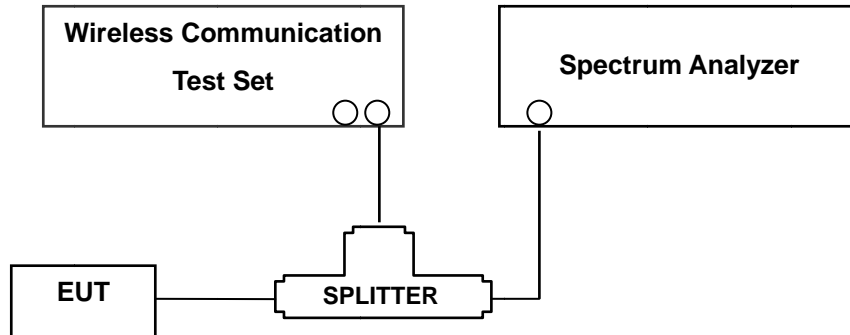

(Configuration of conducted Emission measurement)

The width of a frequency band such that, below the lower and above the upper frequency limits, the mean powers emitted are each equal to a specified percentage 0.5 % of the total mean power of a given emission.

Test Procedure

OBW is tested in accordance with KDB971168 D01 Power Meas License Digital Systems v02r02, October 17, 2014, Section 4.2.

The EUT makes a call to the communication simulator. The power was measured with R&S Spectrum Analyzer. All measurements were done at 3 channels(low, middle and high operational range.)

The conducted occupied bandwidth used the power splitter via EUT RF power connector between simulation base station and spectrum analyzer.

The communication simulator station system controlled a EUT to export maximum output power under transmission mode and specific channel frequency. Use OBW measurement function of Spectrum analyzer to measure 99 % occupied bandwidth

3.4 SPURIOUS AND HARMONIC EMISSIONS AT ANTENNA TERMINAL.

Test Procedure

Spurious and harmonic emissions at antenna terminal is tested in accordance with KDB971168 D01 Power Meas License Digital Systems v02r02, October 17, 2014, Section 6.0.

The level of the carrier and the various conducted spurious and harmonic frequencies is measured by means of a calibrated spectrum analyzer.

The spectrum is scanned from the lowest frequency generated in the equipment up to a frequency including its 10th harmonic. On any frequency outside a licensee's frequency block, the power of any emission shall be attenuated below the transmitter power (P) by at least $43 + 10 \log(P)$ dB. Compliance with these provisions is based on the use of measurement instrumentation employing a resolution bandwidth of 1 MHz or greater. However, in the 100 kHz bands immediately outside and adjacent to the frequency block a resolution bandwidth of at least 30 kHz bandwidth may be employed. The emission bandwidth is defined as the width of the signal between two points, one below the carrier center frequency and one above the carrier center frequency.

NOTES: The analyzer plot offsets were determined by below conditions.

- For LTE Band 12, total offset 26.8 dB = 20 dB attenuator + 6 dB Divider + 0.8 dB RF cables.

3.5 FREQUENCY STABILITY / VARIATION OF AMBIENT TEMPERATURE

Test Set-up

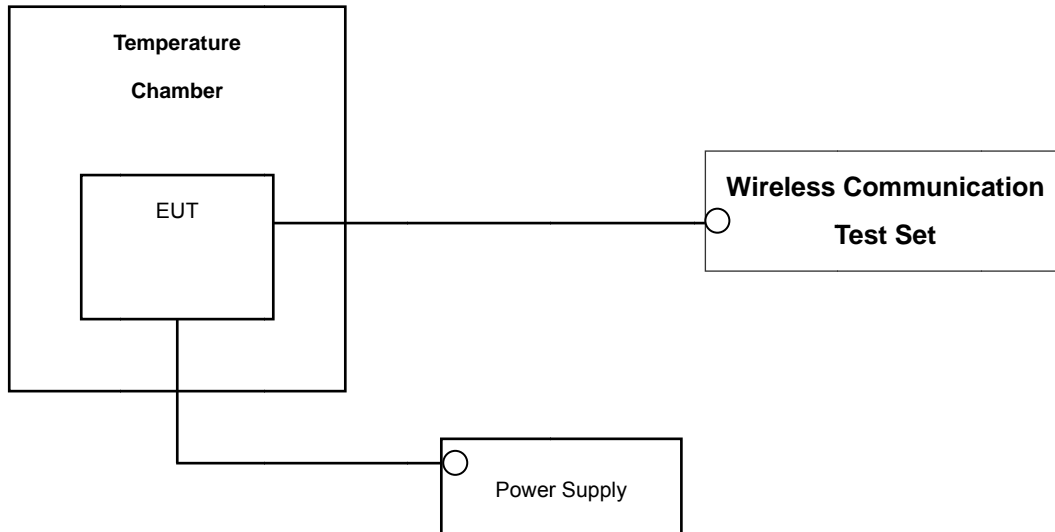

* Nominal Operating Voltage

Test Procedure

Frequency stability is tested in accordance with ANSI/TIA-603-D-2010 section 2.2.2

The frequency stability of the transmitter is measured by:

- a.) **Temperature:** The temperature is varied from - 30 °C to + 50 °C using an environmental chamber.
- b.) **Primary Supply Voltage:** The primary supply voltage is varied from the end point to 100 % of the voltage normally at the input to the device or at the power supply terminals if cables are not normally supplied.

Specification — the frequency stability shall be sufficient to ensure that the fundamental emission stays within the authorized frequency block (LTE Band 12).

Time Period and Procedure:

The carrier frequency of the transmitter is measured at room temperature (20°C to provide a reference).

1. The equipment is turned on in a “standby” condition for one minute before applying power to the transmitter. Measurement of the carrier frequency of the transmitter is made within one minute after applying power to the transmitter.
2. Frequency measurements are made at 10°C intervals ranging from -30°C to +50°C. A period of at least one half-hour is provided to allow stabilization of the equipment at each temperature level.

NOTE: The EUT is tested down to the battery endpoint.

4. LIST OF TEST EQUIPMENT

Manufacture	Model/ Equipment	Serial Number	Calibration Interval	Calibration Due
LG-Innotek	WCD-110 / Wireless Charger	MSIP-RMS-LGE-WCD 110		
DURACELL	DURACELL POWERMAT(CT 06801) / Powermat	34112333855L		
Agilent	N1921A/ Power Sensor	MY45241059	Annual	07/09/2016
Agilent	N1911A/ Power Meter	MY45100523	Annual	07/09/2016
MITEQ	AMF-6D-001180-35-20P/AMP	1081666	Annual	09/03/2016
Wainwright	WHK1.2/15G-10EF/H.P.F	4	Annual	04/27/2016
Wainwright	WHK3.3/18G-10EF/H.P.F	2	Annual	04/27/2016
Hewlett Packard	11667B / Power Splitter	10545	Annual	02/16/2016
Hewlett Packard	11667B / Power Splitter	11275	Annual	04/29/2016
ITECT	IT6720/ Power Supply	010002156267001199	Annual	11/04/2015
Schwarzbeck	UHAP/ Dipole Antenna	557	Biennial	03/23/2017
Schwarzbeck	UHAP/ Dipole Antenna	558	Biennial	03/23/2017
EXP	EX-TH400/ Chamber	None	Annual	05/29/2016
Schwarzbeck	BBHA 9120D/ Horn Antenna	147	Biennial	09/01/2016
Schwarzbeck	BBHA 9120D/ Horn Antenna	1299	Biennial	05/15/2017
Schwarzbeck	BBHA 9170/ Horn Antenna(15~40GHz)	BBHA9170342	Biennial	04/30/2017
Schwarzbeck	BBHA 9170/ Horn Antenna(15~35GHz)	BBHA9170124	Biennial	04/30/2017
Agilent	N9020A/ Signal Analyzer	MY51110063	Annual	04/29/2016
WEINSCHL	ATTENUATOR	BR0592	Annual	10/22/2015
REOHDE&SCHWARZ	FSV40/Spectrum Analyzer	1307.9002K40-100931-NK	Annual	06/04/2016
Anritsu Corp	MT8820C/ Wideband Radio Communication Tester	6200863156	Annual	03/24/2016

5. SUMMARY OF TEST RESULTS

FCC Part Section(s)	Test Description	Test Limit	Test Condition	Test Result
2.1049	Occupied Bandwidth	N/A	CONDUCTED	PASS
2.1051, 27.53(g)	Band Edge / Spurious and Harmonic Emissions at Antenna Terminal.	$< 43 + 10 \log_{10} (P[\text{Watts}])$ at Band Edge and for all-of-band emissions		PASS
*2.1046	Conducted Output Power	N/A		PASS
2.1055, 27.54	Frequency stability / variation of ambient temperature	Emission must remain in band		PASS
27.50(c)(10)	Effective Radiated Power (Band 12)	< 3 Watts max. ERP	RADIATED	PASS
2.1053, 27.53(g)	Undesirable Out-of-Band Emissions	$< 43 + 10 \log_{10} (P[\text{Watts}])$ for all out-of-band emissions		PASS

*: See SAR Report

6. SAMPLE CALCULATION

A. ERP Sample Calculation

Mode	Ch./ Freq.		Measured Level(dBm)	Substitute LEVEL(dBm)	Ant. Gain (dBd)	C.L	Pol.	ERP	
	channel	Freq.(MHz)						W	dBm
LTE Band 12	23095	707.50	-28.85	31.95	-10.21	1.08	H	0.116	20.66

ERP = SubstituteLEVEL(dBm) + Ant. Gain – CL(Cable Loss)

- 1) The EUT mounted on a wooden tripod is 2.5 meter above test site ground level.
- 2) During the test , the turn table is rotated and the antenna height is found.
- 3) Record the field strength meter’s level.
- 4) Replace the EUT with dipole/Horn antenna that is connected to a calibrated signal generator.
- 5) Increase the signal generator output till the field strength meter’s level is equal to the item (3).
- 6) The signal generator output level with Ant. Gain and cable loss are the rating of effective radiated power (ERP).

B. Emission Designator

QPSK Modulation

5MHz Bandwidth

Emission Designator = 4M48G7D

LTE BW = 4.48 MHz

G = Phase Modulation

7 = Quantized/Digital Info

D = Data transmission; telemetry; telecommand

10MHz Bandwidth

Emission Designator = 8M95G7D

LTE BW = 8.95 MHz

G = Phase Modulation

7 = Quantized/Digital Info

D = Data transmission; telemetry; telecommand

16QAM Modulation

5MHz Bandwidth

Emission Designator = 4M48W7D

LTE BW = 4.48 MHz

W = main carrier modulated in a combination of two or more of the following modes;
amplitude, angle, pulse

7 = Quantized/Digital Info

D = Data transmission; telemetry; telecommand

10MHz Bandwidth

Emission Designator = 8M95W7D

LTE BW = 8.95 MHz

W = main carrier modulated in a combination of two or more of the following modes;
amplitude, angle, pulse

7 = Quantized/Digital Info

D = Data transmission; telemetry; telecommand

7. TEST DATA

7.1 EFFECTIVE RADIATED POWER (Band 12)_Standalone with normal cover

Freq (MHz)	Bandwidth	Modulation	Measured Level (dBm)	Substitute Level (dBm)	Ant. Gain(dBd)	C.L	Pol	ERP	
								W	dBm
699.7	1.4 MHz	QPSK	-34.07	27.06	-10.17	0.81	V	0.041	16.08
		16-QAM	-34.90	26.23	-10.17	0.81	V	0.033	15.25
707.5		QPSK	-33.18	27.67	-10.21	0.81	V	0.046	16.65
		16-QAM	-34.00	26.85	-10.21	0.81	V	0.038	15.83
715.3		QPSK	-32.62	28.48	-10.25	0.82	V	0.055	17.41
		16-QAM	-33.40	27.70	-10.25	0.82	V	0.046	16.63

Effective Radiated Power Data (1.4 MHz Band 12 LTE)

Note: All of RB size has been tested for emissions and ERP, with the 1RB configuration observed as the worst case

Freq (MHz)	Bandwidth	Modulation	Measured Level (dBm)	Substitute Level (dBm)	Ant. Gain(dBd)	C.L	Pol	ERP	
								W	dBm
700.5	3 MHz	QPSK	-34.25	26.88	-10.17	0.81	V	0.039	15.90
		16-QAM	-35.12	26.01	-10.17	0.81	V	0.032	15.03
707.5		QPSK	-33.38	27.58	-10.20	0.81	V	0.045	16.57
		16-QAM	-34.21	26.75	-10.20	0.81	V	0.037	15.74
714.5		QPSK	-32.65	28.47	-10.24	0.82	V	0.055	17.41
		16-QAM	-33.52	27.60	-10.24	0.82	V	0.045	16.54

Effective Radiated Power Data (3 MHz Band 12 LTE)

Note: All of RB size has been tested for emissions and ERP, with the 1RB configuration observed as the worst case

Freq (MHz)	Bandwidth	Modulation	Measured Level (dBm)	Substitute Level (dBm)	Ant. Gain(dBd)	C.L	Pol	ERP	
								W	dBm
701.5	5 MHz	QPSK	-34.30	26.83	-10.17	0.81	V	0.038	15.85
		16-QAM	-35.13	26.00	-10.17	0.81	V	0.032	15.02
707.5		QPSK	-33.31	27.66	-10.20	0.81	V	0.046	16.65
		16-QAM	-34.27	26.70	-10.20	0.81	V	0.037	15.69
713.5		QPSK	-34.24	26.69	-10.23	0.82	V	0.037	15.64
		16-QAM	-34.24	26.69	-10.23	0.82	V	0.037	15.64

Effective Radiated Power Data (5 MHz Band 12 LTE)

Note: All of RB size has been tested for emissions and ERP, with the 1RB configuration observed as the worst case

Freq (MHz)	Bandwidth	Modulation	Measured Level (dBm)	Substitute Level (dBm)	Ant. Gain(dBd)	C.L	Pol	ERP	
								W	dBm
704.0	10 MHz	QPSK	-34.06	27.07	-10.17	0.81	V	0.041	16.09
		16-QAM	-34.83	26.30	-10.17	0.81	V	0.034	15.32
707.5		QPSK	-33.47	27.50	-10.19	0.81	V	0.045	16.50
		16-QAM	-34.30	26.67	-10.19	0.81	V	0.037	15.67
711.0		QPSK	-33.09	27.82	-10.21	0.81	V	0.048	16.80
		16-QAM	-33.75	27.16	-10.21	0.81	V	0.041	16.14

Effective Radiated Power Data (10 MHz Band 12 LTE)

Note: All of RB size has been tested for emissions and ERP, with the 1RB configuration observed as the worst case

NOTES:

Effective Radiated Power Output Measurements by Substitution Method according to ANSI/TIA/EIA-603-D-2010 June 24, 2010:

The EUT was placed on a non-conductive styrofoam resin table 3-meters from the receive antenna. The receive antenna height and turntable rotation was adjusted for the highest reading on the receive spectrum analyzer. For LTE signals, RBW = 1-5% of the OBW, not to exceed 1MHz, VBW ≥ 3 x RBW, Detector = RMS. A half-wave dipole was substituted in place of the EUT. This dipole antenna was driven by a signal generator and the level of the signal generator was adjusted to obtain the same receive spectrum analyzer reading. The conducted power at the terminals of the dipole is measured. The ERP is recorded.

Also, we have done x, y, z planes in EUT and horizontal and vertical polarization in detecting antenna. The worst case of the EUT is y plane in LTE mode. Also worst case of detecting Antenna is vertical polarization in LTE mode.

7.2 EFFECTIVE RADIATED POWER (Band 12)_Standalone with wireless charging cover

Freq (MHz)	Bandwidth	Modulation	Measured Level (dBm)	Substitute Level (dBm)	Ant. Gain(dBd)	C.L	Pol	ERP	
								W	dBm
699.7	1.4 MHz	QPSK	-34.35	26.78	-10.17	0.81	V	0.038	15.80
		16-QAM	-35.11	26.02	-10.17	0.81	V	0.032	15.04
707.5		QPSK	-33.17	27.68	-10.21	0.81	V	0.046	16.66
		16-QAM	-34.20	26.65	-10.21	0.81	V	0.037	15.63
715.3		QPSK	-32.70	28.40	-10.25	0.82	V	0.054	17.33
		16-QAM	-33.53	27.57	-10.25	0.82	V	0.045	16.50

Effective Radiated Power Data (1.4 MHz Band 12 LTE)

Note: All of RB size has been tested for emissions and ERP, with the 1RB configuration observed as the worst case

Freq (MHz)	Bandwidth	Modulation	Measured Level (dBm)	Substitute Level (dBm)	Ant. Gain(dBd)	C.L	Pol	ERP	
								W	dBm
700.5	3 MHz	QPSK	-34.44	26.69	-10.17	0.81	V	0.037	15.71
		16-QAM	-35.32	25.81	-10.17	0.81	V	0.030	14.83
707.5		QPSK	-33.54	27.42	-10.20	0.81	V	0.044	16.41
		16-QAM	-34.34	26.62	-10.20	0.81	V	0.036	15.61
714.5		QPSK	-32.66	28.46	-10.24	0.82	V	0.055	17.40
		16-QAM	-33.54	27.58	-10.24	0.82	V	0.045	16.52

Effective Radiated Power Data (3 MHz Band 12 LTE)

Note: All of RB size has been tested for emissions and ERP, with the 1RB configuration observed as the worst case

Freq (MHz)	Bandwidth	Modulation	Measured Level (dBm)	Substitute Level (dBm)	Ant. Gain(dBd)	C.L	Pol	ERP	
								W	dBm
701.5	5 MHz	QPSK	-34.53	26.60	-10.17	0.81	V	0.036	15.62
		16-QAM	-35.28	25.85	-10.17	0.81	V	0.031	14.87
707.5		QPSK	-33.54	27.43	-10.20	0.81	V	0.044	16.42
		16-QAM	-34.39	26.58	-10.20	0.81	V	0.036	15.57
713.5		QPSK	-32.90	28.03	-10.23	0.82	V	0.050	16.98
		16-QAM	-33.72	27.21	-10.23	0.82	V	0.041	16.16

Effective Radiated Power Data (5 MHz Band 12 LTE)

Note: All of RB size has been tested for emissions and ERP, with the 1RB configuration observed as the worst case

Freq (MHz)	Bandwidth	Modulation	Measured Level (dBm)	Substitute Level (dBm)	Ant. Gain(dBd)	C.L	Pol	ERP	
								W	dBm
704.0	10 MHz	QPSK	-34.17	26.96	-10.17	0.81	V	0.040	15.98
		16-QAM	-35.10	26.03	-10.17	0.81	V	0.032	15.05
707.5		QPSK	-33.58	27.39	-10.19	0.81	V	0.044	16.39
		16-QAM	-34.54	26.43	-10.19	0.81	V	0.035	15.43
711.0		QPSK	-33.24	27.67	-10.21	0.81	V	0.046	16.65
		16-QAM	-34.06	26.85	-10.21	0.81	V	0.038	15.83

Effective Radiated Power Data (10 MHz Band 12 LTE)

Note: All of RB size has been tested for emissions and ERP, with the 1RB configuration observed as the worst case

NOTES:

Effective Radiated Power Output Measurements by Substitution Method according to ANSI/TIA/EIA-603-D-2010 June 24, 2010:

The EUT was placed on a non-conductive styrofoam resin table 3-meters from the receive antenna. The receive antenna height and turntable rotation was adjusted for the highest reading on the receive spectrum analyzer. For LTE signals, RBW = 1-5% of the OBW, not to exceed 1MHz, VBW ≥ 3 x RBW, Detector = RMS. A half-wave dipole was substituted in place of the EUT. This dipole antenna was driven by a signal generator and the level of the signal generator was adjusted to obtain the same receive spectrum analyzer reading. The conducted power at the terminals of the dipole is measured. The ERP is recorded.

Also, we have done x, y, z planes in EUT and horizontal and vertical polarization in detecting antenna. The worst case of the EUT is y plane in LTE mode. Also worst case of detecting Antenna is vertical polarization in LTE mode.

7.3 EFFECTIVE RADIATED POWER (Band 12)_With wireless charging pad(WCD-110)

Freq (MHz)	Bandwidth	Modulation	Measured Level (dBm)	Substitute Level (dBm)	Ant. Gain(dBd)	C.L	Pol	ERP	
								W	dBm
699.7	1.4 MHz	QPSK	-33.58	27.55	-10.17	0.81	V	0.045	16.57
		16-QAM	-34.54	26.59	-10.17	0.81	V	0.036	15.61
707.5		QPSK	-33.48	27.37	-10.21	0.81	V	0.043	16.35
		16-QAM	-34.32	26.53	-10.21	0.81	V	0.036	15.51
715.3		QPSK	-33.58	27.52	-10.25	0.82	V	0.044	16.45
		16-QAM	-34.34	26.76	-10.25	0.82	V	0.037	15.69

Effective Radiated Power Data (1.4 MHz Band 12 LTE)

Note: All of RB size has been tested for emissions and ERP, with the 1RB configuration observed as the worst case

Freq (MHz)	Bandwidth	Modulation	Measured Level (dBm)	Substitute Level (dBm)	Ant. Gain(dBd)	C.L	Pol	ERP	
								W	dBm
700.5	3 MHz	QPSK	-33.78	27.35	-10.17	0.81	V	0.043	16.37
		16-QAM	-34.66	26.47	-10.17	0.81	V	0.035	15.49
707.5		QPSK	-33.69	27.27	-10.20	0.81	V	0.042	16.26
		16-QAM	-34.58	26.38	-10.20	0.81	V	0.034	15.37
714.5		QPSK	-33.46	27.66	-10.24	0.82	V	0.046	16.60
		16-QAM	-34.59	26.53	-10.24	0.82	V	0.035	15.47

Effective Radiated Power Data (3 MHz Band 12 LTE)

Note: All of RB size has been tested for emissions and ERP, with the 1RB configuration observed as the worst case

Freq (MHz)	Bandwidth	Modulation	Measured Level (dBm)	Substitute Level (dBm)	Ant. Gain(dBd)	C.L	Pol	ERP	
								W	dBm
701.5	5 MHz	QPSK	-33.92	27.21	-10.17	0.81	V	0.042	16.23
		16-QAM	-34.70	26.43	-10.17	0.81	V	0.035	15.45
707.5		QPSK	-33.53	27.44	-10.20	0.81	V	0.044	16.43
		16-QAM	-34.47	26.50	-10.20	0.81	V	0.035	15.49
713.5		QPSK	-33.58	27.35	-10.23	0.82	V	0.043	16.30
		16-QAM	-34.37	26.56	-10.23	0.82	V	0.036	15.51

Effective Radiated Power Data (5 MHz Band 12 LTE)

Note: All of RB size has been tested for emissions and ERP, with the 1RB configuration observed as the worst case

Freq (MHz)	Bandwidth	Modulation	Measured Level (dBm)	Substitute Level (dBm)	Ant. Gain(dBd)	C.L	Pol	ERP	
								W	dBm
704.0	10 MHz	QPSK	-33.61	27.52	-10.17	0.81	V	0.045	16.54
		16-QAM	-34.46	26.67	-10.17	0.81	V	0.037	15.69
707.5		QPSK	-33.49	27.48	-10.19	0.81	V	0.044	16.48
		16-QAM	-34.44	26.53	-10.19	0.81	V	0.036	15.53
711.0		QPSK	-33.41	27.50	-10.21	0.81	V	0.044	16.48
		16-QAM	-34.28	26.63	-10.21	0.81	V	0.036	15.61

Effective Radiated Power Data (10 MHz Band 12 LTE)

Note: All of RB size has been tested for emissions and ERP, with the 1RB configuration observed as the worst case

NOTES:

Effective Radiated Power Output Measurements by Substitution Method according to ANSI/TIA/EIA-603-D-2010 June 24, 2010:

The EUT was placed on a non-conductive styrofoam resin table 3-meters from the receive antenna. The receive antenna height and turntable rotation was adjusted for the highest reading on the receive spectrum analyzer. For LTE signals, RBW = 1-5% of the OBW, not to exceed 1MHz, VBW ≥ 3 x RBW, Detector = RMS. A half-wave dipole was substituted in place of the EUT. This dipole antenna was driven by a signal generator and the level of the signal generator was adjusted to obtain the same receive spectrum analyzer reading. The conducted power at the terminals of the dipole is measured. The ERP is recorded.

Also, we have done x, y, z planes in EUT and horizontal and vertical polarization in detecting antenna. The worst case of the EUT is y plane in LTE mode. Also worst case of detecting Antenna is vertical polarization in LTE mode.

7.4 EFFECTIVE RADIATED POWER (Band 12)_With wireless charging pad(CT 06801)

Freq (MHz)	Bandwidth	Modulation	Measured Level (dBm)	Substitute Level (dBm)	Ant. Gain(dBd)	C.L	Pol	ERP	
								W	dBm
699.7	1.4 MHz	QPSK	-35.75	25.38	-10.17	0.81	H	0.028	14.40
		16-QAM	-36.51	24.62	-10.17	0.81	H	0.023	13.64
707.5		QPSK	-34.85	26.00	-10.21	0.81	H	0.031	14.98
		16-QAM	-35.77	25.08	-10.21	0.81	H	0.025	14.06
715.3		QPSK	-33.77	27.33	-10.25	0.82	H	0.042	16.26
		16-QAM	-34.60	26.50	-10.25	0.82	H	0.035	15.43

Effective Radiated Power Data (1.4 MHz Band 12 LTE)

Note: All of RB size has been tested for emissions and ERP, with the 1RB configuration observed as the worst case

Freq (MHz)	Bandwidth	Modulation	Measured Level (dBm)	Substitute Level (dBm)	Ant. Gain(dBd)	C.L	Pol	ERP	
								W	dBm
700.5	3 MHz	QPSK	-36.04	25.09	-10.17	0.81	H	0.026	14.11
		16-QAM	-36.85	24.28	-10.17	0.81	H	0.021	13.30
707.5		QPSK	-35.28	25.68	-10.20	0.81	H	0.029	14.67
		16-QAM	-36.26	24.70	-10.20	0.81	H	0.023	13.69
714.5		QPSK	-34.27	26.85	-10.24	0.82	H	0.038	15.79
		16-QAM	-35.29	25.83	-10.24	0.82	H	0.030	14.77

Effective Radiated Power Data (3 MHz Band 12 LTE)

Note: All of RB size has been tested for emissions and ERP, with the 1RB configuration observed as the worst case

Freq (MHz)	Bandwidth	Modulation	Measured Level (dBm)	Substitute Level (dBm)	Ant. Gain(dBd)	C.L	Pol	ERP	
								W	dBm
701.5	5 MHz	QPSK	-36.05	25.08	-10.17	0.81	H	0.026	14.10
		16-QAM	-36.85	24.28	-10.17	0.81	H	0.021	13.30
707.5		QPSK	-35.26	25.71	-10.20	0.81	H	0.030	14.70
		16-QAM	-36.07	24.90	-10.20	0.81	H	0.025	13.89
713.5		QPSK	-34.39	26.54	-10.23	0.82	H	0.035	15.49
		16-QAM	-35.19	25.74	-10.23	0.82	H	0.029	14.69

Effective Radiated Power Data (5 MHz Band 12 LTE)

Note: All of RB size has been tested for emissions and ERP, with the 1RB configuration observed as the worst case

Freq (MHz)	Bandwidth	Modulation	Measured Level (dBm)	Substitute Level (dBm)	Ant. Gain(dBd)	C.L	Pol	ERP	
								W	dBm
704.0	10 MHz	QPSK	-35.89	25.24	-10.17	0.81	H	0.027	14.26
		16-QAM	-36.66	24.47	-10.17	0.81	H	0.022	13.49
707.5		QPSK	-35.34	25.63	-10.19	0.81	H	0.029	14.63
		16-QAM	-36.35	24.62	-10.19	0.81	H	0.023	13.62
711.0		QPSK	-34.90	26.01	-10.21	0.81	H	0.032	14.99
		16-QAM	-35.87	25.04	-10.21	0.81	H	0.025	14.02

Effective Radiated Power Data (10 MHz Band 12 LTE)

Note: All of RB size has been tested for emissions and ERP, with the 1RB configuration observed as the worst case

NOTES:

Effective Radiated Power Output Measurements by Substitution Method according to ANSI/TIA/EIA-603-D-2010 June 24, 2010:

The EUT was placed on a non-conductive styrofoam resin table 3-meters from the receive antenna. The receive antenna height and turntable rotation was adjusted for the highest reading on the receive spectrum analyzer. For LTE signals, RBW = 1-5% of the OBW, not to exceed 1MHz, VBW ≥ 3 x RBW, Detector = RMS. A half-wave dipole was substituted in place of the EUT. This dipole antenna was driven by a signal generator and the level of the signal generator was adjusted to obtain the same receive spectrum analyzer reading. The conducted power at the terminals of the dipole is measured. The ERP is recorded.

Also, we have done x, y, z planes in EUT and horizontal and vertical polarization in detecting antenna. The worst case of the EUT is x plane in LTE mode. Also worst case of detecting Antenna is horizontal polarization in LTE mode.

7.5 RADIATED SPURIOUS EMISSIONS_ Standalone with normal cover

7.5.1 RADIATED SPURIOUS EMISSIONS (1.4 MHz Band 12 LTE)

- ▣ OPERATING FREQUENCY : 715.30 MHz
- ▣ MEASURED OUTPUT POWER: 17.41 dBm = 0.055 W
- ▣ MODULATION SIGNAL: 1.4 MHz QPSK
- ▣ DISTANCE: 3 meters
- ▣ LIMIT: $43 + 10 \log_{10}(W) =$ 30.41 dBc

Ch	Freq (MHz)	Measured Level (dBm)	Ant. Gain (dBd)	Substitute Level (dBm)	C.L	Pol	ERP (dBm)	dBc
23017 (699.7)	1,399.40	-53.73	7.73	-59.09	1.17	V	-52.53	69.94
	2,099.10	-58.40	9.70	-64.09	1.45	V	-55.84	73.25
	2,798.80	-59.73	10.74	-63.81	1.70	V	-54.77	72.18
23095 (707.5)	1,415.00	-51.93	7.83	-57.68	1.19	V	-51.04	68.45
	2,122.50	-56.38	9.54	-61.39	1.46	V	-53.31	70.72
	2,830.00	-57.81	10.86	-61.72	1.70	H	-52.56	69.97
23173 (715.3)	1,450.60	-50.70	8.05	-56.39	1.19	V	-49.53	66.94
	2,175.90	-56.26	9.23	-60.02	1.48	H	-52.27	69.68
	2,901.20	-57.70	11.03	-61.91	1.73	V	-52.61	70.02

- NOTES:**
1. Radiated Spurious Emission Measurements at 3 meters by Substitution Method according to ANSI/TIA/EIA-603-D-2010 June 24, 2010:
 2. We are performed all frequency to 10th harmonics from 30 MHz. Measurements above show only up to 3 maximum emissions noted, or would be lesser if no specific emissions from the EUT are recorded (ie: margin > 20 dB from the applicable limit) and considered that's already beyond the background noise floor.
 3. we have done x, y, z planes in EUT and horizontal and vertical polarization in detecting antenna.
 4. All of RB size has been tested for emissions and ERP, with the 1RB configuration observed as the worst case
 5. We are performed 16QAM and QPSK modulations. The worst case data are reported in the table above.

7.5.2 RADIATED SPURIOUS EMISSIONS (3 MHz Band 12 LTE)

- ▣ OPERATING FREQUENCY : 714.50 MHz
- ▣ MEASURED OUTPUT POWER: 17.41 dBm = 0.055 W
- ▣ MODULATION SIGNAL: 3 MHz QPSK
- ▣ DISTANCE: 3 meters
- ▣ LIMIT: $43 + 10 \log_{10}(W) =$ 30.41 dBc

Ch	Freq (MHz)	Measured Level (dBm)	Ant. Gain (dBd)	Substitute Level (dBm)	C.L	Pol	ERP (dBm)	dBc
23025 (700.5)	1,401.00	-54.35	7.75	-59.71	1.17	V	-53.13	70.54
	2,101.50	-57.85	9.68	-63.41	1.45	H	-55.18	72.59
	2,802.00	-59.38	10.75	-63.43	1.70	V	-54.38	71.79
23095 (707.5)	1,415.00	-52.45	7.83	-58.20	1.19	V	-51.56	68.97
	2,122.50	-58.39	9.54	-63.40	1.46	H	-55.32	72.73
	2,830.00	-57.40	10.86	-61.31	1.70	V	-52.15	69.56
23165 (714.5)	1,429.00	-53.11	7.91	-58.67	1.19	V	-51.95	69.36
	2,143.50	-57.18	9.40	-61.63	1.46	V	-53.70	71.11
	2,858.00	-59.59	10.96	-63.70	1.70	H	-54.44	71.85

- NOTES:**
1. Radiated Spurious Emission Measurements at 3 meters by Substitution Method according to ANSI/TIA/EIA-603-D-2010 June 24, 2010:
 2. We are performed all frequency to 10th harmonics from 30 MHz. Measurements above show only up to 3 maximum emissions noted, or would be lesser if no specific emissions from the EUT are recorded (ie: margin > 20 dB from the applicable limit) and considered that's already beyond the background noise floor.
 3. we have done x, y, z planes in EUT and horizontal and vertical polarization in detecting antenna.
 4. All of RB size has been tested for emissions and ERP, with the 1RB configuration observed as the worst case
 5. We are performed 16QAM and QPSK modulations. The worst case data are reported in the table above.

7.5.3 RADIATED SPURIOUS EMISSIONS (5 MHz Band 12 LTE)

- ▣ OPERATING FREQUENCY : 707.50 MHz
- ▣ MEASURED OUTPUT POWER: 16.65 dBm = 0.046 W
- ▣ MODULATION SIGNAL: 5 MHz QPSK
- ▣ DISTANCE: 3 meters
- ▣ LIMIT: $43 + 10 \log_{10}(W) =$ 29.65 dBc

Ch	Freq (MHz)	Measured Level (dBm)	Ant. Gain (dBd)	Substitute Level (dBm)	C.L	Pol	ERP (dBm)	dBc
23035 (701.5)	1,403.00	-54.19	7.76	-59.65	1.17	V	-53.06	69.71
	2,104.50	-59.29	9.66	-64.64	1.45	V	-56.43	73.08
	2,806.00	-59.05	10.76	-62.93	1.71	V	-53.88	70.53
23095 (707.5)	1,415.00	-51.46	7.83	-57.21	1.19	V	-50.57	67.22
	2,122.50	-59.11	9.54	-64.12	1.46	V	-56.04	72.69
	2,830.00	-59.96	10.86	-63.87	1.70	V	-54.71	71.36
23155 (713.5)	1,427.00	-54.50	7.90	-60.09	1.19	V	-53.38	70.03
	2,140.50	-57.61	9.42	-62.09	1.46	H	-54.13	70.78
	2,854.00	-58.49	10.95	-62.57	1.69	H	-53.31	69.96

- NOTES:**
1. Radiated Spurious Emission Measurements at 3 meters by Substitution Method according to ANSI/TIA/EIA-603-D-2010 June 24, 2010:
 2. We are performed all frequency to 10th harmonics from 30 MHz. Measurements above show only up to 3 maximum emissions noted, or would be lesser if no specific emissions from the EUT are recorded (ie: margin > 20 dB from the applicable limit) and considered that's already beyond the background noise floor.
 3. we have done x, y, z planes in EUT and horizontal and vertical polarization in detecting antenna.
 4. All of RB size has been tested for emissions and ERP, with the 1RB configuration observed as the worst case
 5. We are performed 16QAM and QPSK modulations. The worst case data are reported in the table above.

7.5.4 RADIATED SPURIOUS EMISSIONS (10 MHz Band 12 LTE)

- ▣ OPERATING FREQUENCY : 711.00 MHz
- ▣ MEASURED OUTPUT POWER: 16.80 dBm = 0.048 W
- ▣ MODULATION SIGNAL: 10 MHz QPSK
- ▣ DISTANCE: 3 meters
- ▣ LIMIT: $43 + 10 \log_{10}(W) =$ 29.80 dBc

Ch	Freq (MHz)	Measured Level (dBm)	Ant. Gain (dBd)	Substitute Level (dBm)	C.L	Pol	ERP (dBm)	dBc
23060 (704.0)	1,408.00	-54.26	7.79	-59.97	1.18	V	-53.36	70.16
	2,112.00	-57.63	9.61	-62.68	1.45	V	-54.52	71.32
	2,816.00	-59.80	10.80	-63.77	1.72	V	-54.69	71.49
23095 (707.5)	1,415.00	-53.00	7.83	-58.75	1.19	V	-52.11	68.91
	2,122.50	-58.02	9.54	-63.03	1.46	H	-54.95	71.75
	2,830.00	-58.20	10.86	-62.11	1.70	H	-52.95	69.75
23130 (711.0)	1,422.00	-51.79	7.87	-57.46	1.19	V	-50.78	67.58
	2,133.00	-58.11	9.47	-62.57	1.45	V	-54.55	71.35
	2,844.00	-59.44	10.92	-63.40	1.71	H	-54.19	70.99

- NOTES:**
1. Radiated Spurious Emission Measurements at 3 meters by Substitution Method according to ANSI/TIA/EIA-603-D-2010 June 24, 2010:
 2. We are performed all frequency to 10th harmonics from 30 MHz. Measurements above show only up to 3 maximum emissions noted, or would be lesser if no specific emissions from the EUT are recorded (ie: margin > 20 dB from the applicable limit) and considered that's already beyond the background noise floor.
 3. we have done x, y, z planes in EUT and horizontal and vertical polarization in detecting antenna.
 4. All of RB size has been tested for emissions and ERP, with the 1RB configuration observed as the worst case
 5. We are performed 16QAM and QPSK modulations. The worst case data are reported in the table above.

7.6 RADIATED SPURIOUS EMISSIONS_ Standalone with wireless charging cover

7.6.1 RADIATED SPURIOUS EMISSIONS (1.4 MHz Band 12 LTE)

- ▣ OPERATING FREQUENCY : 715.30 MHz
- ▣ MEASURED OUTPUT POWER: 17.33 dBm = 0.054 W
- ▣ MODULATION SIGNAL: 1.4 MHz QPSK
- ▣ DISTANCE: 3 meters
- ▣ LIMIT: $43 + 10 \log_{10}(W) =$ 30.33 dBc

Ch	Freq (MHz)	Measured Level (dBm)	Ant. Gain (dBd)	Substitute Level (dBm)	C.L	Pol	ERP (dBm)	dBc
23017 (699.7)	1,399.40	-48.11	7.73	-53.47	1.17	H	-46.91	64.24
	2,099.10	-39.40	9.70	-45.09	1.45	H	-36.84	54.17
	2,798.80	-58.80	10.74	-62.88	1.70	H	-53.84	71.17
23095 (707.5)	1,415.00	-51.78	7.83	-57.53	1.19	H	-50.89	68.22
	2,122.50	-38.50	9.54	-43.51	1.46	H	-35.43	52.76
	2,830.00	-56.96	10.86	-60.87	1.70	H	-51.71	69.04
23173 (715.3)	1,450.60	-52.47	8.05	-58.16	1.19	H	-51.30	68.63
	2,175.90	-40.15	9.23	-43.91	1.48	H	-36.16	53.49
	2,901.20	-57.50	11.03	-61.71	1.73	H	-52.41	69.74

- NOTES:**
1. Radiated Spurious Emission Measurements at 3 meters by Substitution Method according to ANSI/TIA/EIA-603-D-2010 June 24, 2010:
 2. We are performed all frequency to 10th harmonics from 30 MHz. Measurements above show only up to 3 maximum emissions noted, or would be lesser if no specific emissions from the EUT are recorded (ie: margin > 20 dB from the applicable limit) and considered that's already beyond the background noise floor.
 3. we have done x, y, z planes in EUT and horizontal and vertical polarization in detecting antenna.
 4. All of RB size has been tested for emissions and ERP, with the 1RB configuration observed as the worst case
 5. We are performed 16QAM and QPSK modulations. The worst case data are reported in the table above.

7.6.2 RADIATED SPURIOUS EMISSIONS (3 MHz Band 12 LTE)

- ▣ OPERATING FREQUENCY : 714.50 MHz
- ▣ MEASURED OUTPUT POWER: 17.40 dBm = 0.055 W
- ▣ MODULATION SIGNAL: 3 MHz QPSK
- ▣ DISTANCE: 3 meters
- ▣ LIMIT: $43 + 10 \log_{10}(W) =$ 30.40 dBc

Ch	Freq (MHz)	Measured Level (dBm)	Ant. Gain (dBd)	Substitute Level (dBm)	C.L	Pol	ERP (dBm)	dBc
23025 (700.5)	1,401.00	-50.63	7.75	-55.99	1.17	H	-49.41	66.81
	2,101.50	-48.29	9.68	-53.85	1.45	H	-45.62	63.02
	2,802.00	-57.31	10.75	-61.36	1.70	H	-52.31	69.71
23095 (707.5)	1,415.00	-53.13	7.83	-58.88	1.19	H	-52.24	69.64
	2,122.50	-47.12	9.54	-52.13	1.46	H	-44.05	61.45
	2,830.00	-58.08	10.86	-61.99	1.70	H	-52.83	70.23
23165 (714.5)	1,429.00	-51.55	7.91	-57.11	1.19	H	-50.39	67.79
	2,143.50	-47.33	9.40	-51.78	1.46	H	-43.85	61.25
	2,858.00	-57.31	10.96	-61.42	1.70	H	-52.16	69.56

- NOTES:**
1. Radiated Spurious Emission Measurements at 3 meters by Substitution Method according to ANSI/TIA/EIA-603-D-2010 June 24, 2010:
 2. We are performed all frequency to 10th harmonics from 30 MHz. Measurements above show only up to 3 maximum emissions noted, or would be lesser if no specific emissions from the EUT are recorded (ie: margin > 20 dB from the applicable limit) and considered that's already beyond the background noise floor.
 3. we have done x, y, z planes in EUT and horizontal and vertical polarization in detecting antenna.
 4. All of RB size has been tested for emissions and ERP, with the 1RB configuration observed as the worst case
 5. We are performed 16QAM and QPSK modulations. The worst case data are reported in the table above.

7.6.3 RADIATED SPURIOUS EMISSIONS (5 MHz Band 12 LTE)

- ▣ OPERATING FREQUENCY : 713.50 MHz
- ▣ MEASURED OUTPUT POWER: 16.98 dBm = 0.050 W
- ▣ MODULATION SIGNAL: 5 MHz QPSK
- ▣ DISTANCE: 3 meters
- ▣ LIMIT: $43 + 10 \log_{10}(W) =$ 29.98 dBc

Ch	Freq (MHz)	Measured Level (dBm)	Ant. Gain (dBd)	Substitute Level (dBm)	C.L	Pol	ERP (dBm)	dBc
23035 (701.5)	1,403.00	-51.48	7.76	-56.94	1.17	H	-50.35	67.33
	2,104.50	-47.82	9.66	-53.17	1.45	H	-44.96	61.94
	2,806.00	-55.75	10.76	-59.63	1.71	H	-50.58	67.56
23095 (707.5)	1,415.00	-52.97	7.83	-58.72	1.19	H	-52.08	69.06
	2,122.50	-44.83	9.54	-49.84	1.46	H	-41.76	58.74
	2,830.00	-58.44	10.86	-62.35	1.70	H	-53.19	70.17
23155 (713.5)	1,427.00	-53.10	7.90	-58.69	1.19	H	-51.98	68.96
	2,140.50	-47.04	9.42	-51.52	1.46	H	-43.56	60.54
	2,854.00	-59.83	10.95	-63.91	1.69	H	-54.65	71.63

- NOTES:**
1. Radiated Spurious Emission Measurements at 3 meters by Substitution Method according to ANSI/TIA/EIA-603-D-2010 June 24, 2010:
 2. We are performed all frequency to 10th harmonics from 30 MHz. Measurements above show only up to 3 maximum emissions noted, or would be lesser if no specific emissions from the EUT are recorded (ie: margin > 20 dB from the applicable limit) and considered that's already beyond the background noise floor.
 3. we have done x, y, z planes in EUT and horizontal and vertical polarization in detecting antenna.
 4. All of RB size has been tested for emissions and ERP, with the 1RB configuration observed as the worst case
 5. We are performed 16QAM and QPSK modulations. The worst case data are reported in the table above.

7.6.4 RADIATED SPURIOUS EMISSIONS (10 MHz Band 12 LTE)

- ▣ OPERATING FREQUENCY : 711.00 MHz
- ▣ MEASURED OUTPUT POWER: 16.65 dBm = 0.046 W
- ▣ MODULATION SIGNAL: 10 MHz QPSK
- ▣ DISTANCE: 3 meters
- ▣ LIMIT: $43 + 10 \log_{10}(W) =$ 29.65 dBc

Ch	Freq (MHz)	Measured Level (dBm)	Ant. Gain (dBd)	Substitute Level (dBm)	C.L	Pol	ERP (dBm)	dBc
23060 (704.0)	1,408.00	-51.69	7.79	-57.40	1.18	H	-50.79	67.44
	2,112.00	-46.59	9.61	-51.64	1.45	H	-43.48	60.13
	2,816.00	-59.14	10.80	-63.11	1.72	H	-54.03	70.68
23095 (707.5)	1,415.00	-53.74	7.83	-59.49	1.19	H	-52.85	69.50
	2,122.50	-45.18	9.54	-50.19	1.46	H	-42.11	58.76
	2,830.00	-57.49	10.86	-61.40	1.70	H	-52.24	68.89
23130 (711.0)	1,422.00	-52.95	7.87	-58.62	1.19	H	-51.94	68.59
	2,133.00	-46.66	9.47	-51.12	1.45	H	-43.10	59.75
	2,844.00	-58.34	10.92	-62.30	1.71	H	-53.09	69.74

- NOTES:**
1. Radiated Spurious Emission Measurements at 3 meters by Substitution Method according to ANSI/TIA/EIA-603-D-2010 June 24, 2010:
 2. We are performed all frequency to 10th harmonics from 30 MHz. Measurements above show only up to 3 maximum emissions noted, or would be lesser if no specific emissions from the EUT are recorded (ie: margin > 20 dB from the applicable limit) and considered that's already beyond the background noise floor.
 3. we have done x, y, z planes in EUT and horizontal and vertical polarization in detecting antenna.
 4. All of RB size has been tested for emissions and ERP, with the 1RB configuration observed as the worst case
 5. We are performed 16QAM and QPSK modulations. The worst case data are reported in the table above.

7.7 RADIATED SPURIOUS EMISSIONS_With wireless charging pad(WCD-110)

7.7.1 RADIATED SPURIOUS EMISSIONS (1.4 MHz Band 12 LTE)

- ▣ OPERATING FREQUENCY : 699.70 MHz
- ▣ MEASURED OUTPUT POWER: 16.57 dBm = 0.045 W
- ▣ MODULATION SIGNAL: 1.4 MHz QPSK
- ▣ DISTANCE: 3 meters
- ▣ LIMIT: $43 + 10 \log_{10}(W) =$ 29.57 dBc

Ch	Freq (MHz)	Measured Level (dBm)	Ant. Gain (dBd)	Substitute Level (dBm)	C.L	Pol	ERP (dBm)	dBc
23017 (699.7)	1,399.40	-53.55	7.73	-58.91	1.17	H	-52.35	68.92
	2,099.10	-48.88	9.70	-54.57	1.45	H	-46.32	62.89
	2,798.80	-57.79	10.74	-61.87	1.70	H	-52.83	69.40
23095 (707.5)	1,415.00	-52.16	7.83	-57.91	1.19	H	-51.27	67.84
	2,122.50	-50.01	9.54	-55.02	1.46	H	-46.94	63.51
	2,830.00	-58.60	10.86	-62.51	1.70	H	-53.35	69.92
23173 (715.3)	1,450.60	-50.31	8.05	-56.00	1.19	H	-49.14	65.71
	2,175.90	-50.01	9.23	-53.77	1.48	H	-46.02	62.59
	2,901.20	-57.29	11.03	-61.50	1.73	H	-52.20	68.77

NOTES: 1. Radiated Spurious Emission Measurements at 3 meters by Substitution Method

according to ANSI/TIA/EIA-603-D-2010 June 24, 2010:

2. We are performed all frequency to 10th harmonics from 30 MHz. Measurements above show only up to 3 maximum emissions noted, or would be lesser if no specific emissions from the EUT are recorded (ie: margin > 20 dB from the applicable limit) and considered that's already beyond the background noise floor.
3. we have done x, y, z planes in EUT and horizontal and vertical polarization in detecting antenna.
4. All of RB size has been tested for emissions and ERP, with the 1RB configuration observed as the worst case
5. We are performed 16QAM and QPSK modulations. The worst case data are reported in the table above.

7.7.2 RADIATED SPURIOUS EMISSIONS (3 MHz Band 12 LTE)

- ▣ OPERATING FREQUENCY : 714.50 MHz
- ▣ MEASURED OUTPUT POWER: 16.60 dBm = 0.046 W
- ▣ MODULATION SIGNAL: 3 MHz QPSK
- ▣ DISTANCE: 3 meters
- ▣ LIMIT: $43 + 10 \log_{10}(W) =$ 29.60 dBc

Ch	Freq (MHz)	Measured Level (dBm)	Ant. Gain (dBd)	Substitute Level (dBm)	C.L	Pol	ERP (dBm)	dBc
23025 (700.5)	1,401.00	-55.66	7.75	-61.02	1.17	H	-54.44	71.04
	2,101.50	-48.36	9.68	-53.92	1.45	H	-45.69	62.29
	2,802.00	-58.76	10.75	-62.81	1.70	H	-53.76	70.36
23095 (707.5)	1,415.00	-52.00	7.83	-57.75	1.19	H	-51.11	67.71
	2,122.50	-48.75	9.54	-53.76	1.46	H	-45.68	62.28
	2,830.00	-59.10	10.86	-63.01	1.70	H	-53.85	70.45
23165 (714.5)	1,429.00	-52.22	7.91	-57.78	1.19	H	-51.06	67.66
	2,143.50	-52.07	9.40	-56.52	1.46	H	-48.59	65.19
	2,858.00	-59.54	10.96	-63.65	1.70	H	-54.39	70.99

- NOTES:**
1. Radiated Spurious Emission Measurements at 3 meters by Substitution Method according to ANSI/TIA/EIA-603-D-2010 June 24, 2010:
 2. We are performed all frequency to 10th harmonics from 30 MHz. Measurements above show only up to 3 maximum emissions noted, or would be lesser if no specific emissions from the EUT are recorded (ie: margin > 20 dB from the applicable limit) and considered that's already beyond the background noise floor.
 3. we have done x, y, z planes in EUT and horizontal and vertical polarization in detecting antenna.
 4. All of RB size has been tested for emissions and ERP, with the 1RB configuration observed as the worst case
 5. We are performed 16QAM and QPSK modulations. The worst case data are reported in the table above.

7.7.3 RADIATED SPURIOUS EMISSIONS (5 MHz Band 12 LTE)

- ▣ OPERATING FREQUENCY : 707.50 MHz
- ▣ MEASURED OUTPUT POWER: 16.43 dBm = 0.044 W
- ▣ MODULATION SIGNAL: 5 MHz QPSK
- ▣ DISTANCE: 3 meters
- ▣ LIMIT: $43 + 10 \log_{10}(W) =$ 29.43 dBc

Ch	Freq (MHz)	Measured Level (dBm)	Ant. Gain (dBd)	Substitute Level (dBm)	C.L	Pol	ERP (dBm)	dBc
23035 (701.5)	1,403.00	-52.66	7.76	-58.12	1.17	H	-51.53	67.96
	2,104.50	-48.45	9.66	-53.80	1.45	H	-45.59	62.02
	2,806.00	-59.47	10.76	-63.35	1.71	H	-54.30	70.73
23095 (707.5)	1,415.00	-51.97	7.83	-57.72	1.19	H	-51.08	67.51
	2,122.50	-49.03	9.54	-54.04	1.46	H	-45.96	62.39
	2,830.00	-60.01	10.86	-63.92	1.70	H	-54.76	71.19
23155 (713.5)	1,427.00	-51.53	7.90	-57.12	1.19	H	-50.41	66.84
	2,140.50	-49.29	9.42	-53.77	1.46	H	-45.81	62.24
	2,854.00	-60.08	10.95	-64.16	1.69	H	-54.90	71.33

- NOTES:**
1. Radiated Spurious Emission Measurements at 3 meters by Substitution Method according to ANSI/TIA/EIA-603-D-2010 June 24, 2010:
 2. We are performed all frequency to 10th harmonics from 30 MHz. Measurements above show only up to 3 maximum emissions noted, or would be lesser if no specific emissions from the EUT are recorded (ie: margin > 20 dB from the applicable limit) and considered that's already beyond the background noise floor.
 3. we have done x, y, z planes in EUT and horizontal and vertical polarization in detecting antenna.
 4. All of RB size has been tested for emissions and ERP, with the 1RB configuration observed as the worst case
 5. We are performed 16QAM and QPSK modulations. The worst case data are reported in the table above.

7.7.4 RADIATED SPURIOUS EMISSIONS (10 MHz Band 12 LTE)

- ▣ OPERATING FREQUENCY : 704.00 MHz
- ▣ MEASURED OUTPUT POWER: 16.54 dBm = 0.045 W
- ▣ MODULATION SIGNAL: 10 MHz QPSK
- ▣ DISTANCE: 3 meters
- ▣ LIMIT: $43 + 10 \log_{10}(W) =$ 29.54 dBc

Ch	Freq (MHz)	Measured Level (dBm)	Ant. Gain (dBd)	Substitute Level (dBm)	C.L	Pol	ERP (dBm)	dBc
23060 (704.0)	1,408.00	-51.72	7.79	-57.43	1.18	H	-50.82	67.36
	2,112.00	-47.47	9.61	-52.52	1.45	H	-44.36	60.90
	2,816.00	-60.42	10.80	-64.39	1.72	H	-55.31	71.85
23095 (707.5)	1,415.00	-52.96	7.83	-58.71	1.19	H	-52.07	68.61
	2,122.50	-48.02	9.54	-53.03	1.46	H	-44.95	61.49
	2,830.00	-59.71	10.86	-63.62	1.70	H	-54.46	71.00
23130 (711.0)	1,422.00	-52.65	7.87	-58.32	1.19	H	-51.64	68.18
	2,133.00	-47.95	9.47	-52.41	1.45	H	-44.39	60.93
	2,844.00	-59.06	10.92	-63.02	1.71	H	-53.81	70.35

- NOTES:**
1. Radiated Spurious Emission Measurements at 3 meters by Substitution Method according to ANSI/TIA/EIA-603-D-2010 June 24, 2010:
 2. We are performed all frequency to 10th harmonics from 30 MHz. Measurements above show only up to 3 maximum emissions noted, or would be lesser if no specific emissions from the EUT are recorded (ie: margin > 20 dB from the applicable limit) and considered that's already beyond the background noise floor.
 3. we have done x, y, z planes in EUT and horizontal and vertical polarization in detecting antenna.
 4. All of RB size has been tested for emissions and ERP, with the 1RB configuration observed as the worst case
 5. We are performed 16QAM and QPSK modulations. The worst case data are reported in the table above.

7.8 RADIATED SPURIOUS EMISSIONS_With wireless charging pad(CT 06801)

7.8.1 RADIATED SPURIOUS EMISSIONS (1.4 MHz Band 12 LTE)

- ▣ OPERATING FREQUENCY : 715.30 MHz
- ▣ MEASURED OUTPUT POWER: 16.26 dBm = 0.042 W
- ▣ MODULATION SIGNAL: 1.4 MHz QPSK
- ▣ DISTANCE: 3 meters
- ▣ LIMIT: $43 + 10 \log_{10}(W) =$ 29.26 dBc

Ch	Freq (MHz)	Measured Level (dBm)	Ant. Gain (dBd)	Substitute Level (dBm)	C.L	Pol	ERP (dBm)	dBc
23017 (699.7)	1,399.40	-52.64	7.73	-58.00	1.17	H	-51.44	67.70
	2,099.10	-54.46	9.70	-60.15	1.45	H	-51.90	68.16
	2,798.80	-59.67	10.74	-63.75	1.70	H	-54.71	70.97
23095 (707.5)	1,415.00	-50.72	7.83	-56.47	1.19	H	-49.83	66.09
	2,122.50	-56.24	9.54	-61.25	1.46	H	-53.17	69.43
	2,830.00	-59.01	10.86	-62.92	1.70	H	-53.76	70.02
23173 (715.3)	1,450.60	-49.85	8.05	-55.54	1.19	H	-48.68	64.94
	2,175.90	-57.38	9.23	-61.14	1.48	H	-53.39	69.65
	2,901.20	-59.00	11.03	-63.21	1.73	H	-53.91	70.17

- NOTES:**
1. Radiated Spurious Emission Measurements at 3 meters by Substitution Method according to ANSI/TIA/EIA-603-D-2010 June 24, 2010:
 2. We are performed all frequency to 10th harmonics from 30 MHz. Measurements above show only up to 3 maximum emissions noted, or would be lesser if no specific emissions from the EUT are recorded (ie: margin > 20 dB from the applicable limit) and considered that's already beyond the background noise floor.
 3. we have done x, y, z planes in EUT and horizontal and vertical polarization in detecting antenna.
 4. All of RB size has been tested for emissions and ERP, with the 1RB configuration observed as the worst case
 5. We are performed 16QAM and QPSK modulations. The worst case data are reported in the table above.

7.8.2 RADIATED SPURIOUS EMISSIONS (3 MHz Band 12 LTE)

- ▣ OPERATING FREQUENCY : 714.50 MHz
- ▣ MEASURED OUTPUT POWER: 15.79 dBm = 0.038 W
- ▣ MODULATION SIGNAL: 3 MHz QPSK
- ▣ DISTANCE: 3 meters
- ▣ LIMIT: $43 + 10 \log_{10}(W) =$ 28.79 dBc

Ch	Freq (MHz)	Measured Level (dBm)	Ant. Gain (dBd)	Substitute Level (dBm)	C.L	Pol	ERP (dBm)	dBc
23025 (700.5)	1,401.00	-52.90	7.75	-58.26	1.17	H	-51.68	67.47
	2,101.50	-53.30	9.68	-58.86	1.45	H	-50.63	66.42
	2,802.00	-58.38	10.75	-62.43	1.70	H	-53.38	69.17
23095 (707.5)	1,415.00	-50.26	7.83	-56.01	1.19	H	-49.37	65.16
	2,122.50	-52.90	9.54	-57.91	1.46	H	-49.83	65.62
	2,830.00	-57.00	10.86	-60.91	1.70	H	-51.75	67.54
23165 (714.5)	1,429.00	-53.24	7.91	-58.80	1.19	H	-52.08	67.87
	2,143.50	-53.78	9.40	-58.23	1.46	H	-50.30	66.09
	2,858.00	-57.19	10.96	-61.30	1.70	H	-52.04	67.83

- NOTES:**
1. Radiated Spurious Emission Measurements at 3 meters by Substitution Method according to ANSI/TIA/EIA-603-D-2010 June 24, 2010:
 2. We are performed all frequency to 10th harmonics from 30 MHz. Measurements above show only up to 3 maximum emissions noted, or would be lesser if no specific emissions from the EUT are recorded (ie: margin > 20 dB from the applicable limit) and considered that's already beyond the background noise floor.
 3. we have done x, y, z planes in EUT and horizontal and vertical polarization in detecting antenna.
 4. All of RB size has been tested for emissions and ERP, with the 1RB configuration observed as the worst case
 5. We are performed 16QAM and QPSK modulations. The worst case data are reported in the table above.

7.8.3 RADIATED SPURIOUS EMISSIONS (5 MHz Band 12 LTE)

- ▣ OPERATING FREQUENCY : 713.50 MHz
- ▣ MEASURED OUTPUT POWER: 15.49 dBm = 0.035 W
- ▣ MODULATION SIGNAL: 5 MHz QPSK
- ▣ DISTANCE: 3 meters
- ▣ LIMIT: $43 + 10 \log_{10}(W) =$ 28.49 dBc

Ch	Freq (MHz)	Measured Level (dBm)	Ant. Gain (dBd)	Substitute Level (dBm)	C.L	Pol	ERP (dBm)	dBc
23035 (701.5)	1,403.00	-53.63	7.76	-59.09	1.17	H	-52.50	67.99
	2,104.50	-54.97	9.66	-60.32	1.45	H	-52.11	67.60
	2,806.00	-57.23	10.76	-61.11	1.71	H	-52.06	67.55
23095 (707.5)	1,415.00	-49.37	7.83	-55.12	1.19	H	-48.48	63.97
	2,122.50	-52.94	9.54	-57.95	1.46	H	-49.87	65.36
	2,830.00	-56.69	10.86	-60.60	1.70	H	-51.44	66.93
23155 (713.5)	1,427.00	-52.68	7.90	-58.27	1.19	H	-51.56	67.05
	2,140.50	-53.76	9.42	-58.24	1.46	H	-50.28	65.77
	2,854.00	-56.53	10.95	-60.61	1.69	H	-51.35	66.84

- NOTES:**
1. Radiated Spurious Emission Measurements at 3 meters by Substitution Method according to ANSI/TIA/EIA-603-D-2010 June 24, 2010:
 2. We are performed all frequency to 10th harmonics from 30 MHz. Measurements above show only up to 3 maximum emissions noted, or would be lesser if no specific emissions from the EUT are recorded (ie: margin > 20 dB from the applicable limit) and considered that's already beyond the background noise floor.
 3. we have done x, y, z planes in EUT and horizontal and vertical polarization in detecting antenna.
 4. All of RB size has been tested for emissions and ERP, with the 1RB configuration observed as the worst case
 5. We are performed 16QAM and QPSK modulations. The worst case data are reported in the table above.

7.8.4 RADIATED SPURIOUS EMISSIONS (10 MHz Band 12 LTE)

- ▣ OPERATING FREQUENCY : 711.00 MHz
- ▣ MEASURED OUTPUT POWER: 14.99 dBm = 0.032 W
- ▣ MODULATION SIGNAL: 10 MHz QPSK
- ▣ DISTANCE: 3 meters
- ▣ LIMIT: $43 + 10 \log_{10}(W) =$ 27.99 dBc

Ch	Freq (MHz)	Measured Level (dBm)	Ant. Gain (dBd)	Substitute Level (dBm)	C.L	Pol	ERP (dBm)	dBc
23060 (704.0)	1,408.00	-54.10	7.79	-59.81	1.18	H	-53.20	68.19
	2,112.00	-58.33	9.61	-63.38	1.45	H	-55.22	70.21
	2,816.00	-59.12	10.80	-63.09	1.72	H	-54.01	69.00
23095 (707.5)	1,415.00	-50.49	7.83	-56.24	1.19	H	-49.60	64.59
	2,122.50	-54.69	9.54	-59.70	1.46	H	-51.62	66.61
	2,830.00	-58.44	10.86	-62.35	1.70	H	-53.19	68.18
23130 (711.0)	1,422.00	-51.16	7.87	-56.83	1.19	H	-50.15	65.14
	2,133.00	-52.73	9.47	-57.19	1.45	H	-49.17	64.16
	2,844.00	-57.13	10.92	-61.09	1.71	H	-51.88	66.87

- NOTES:**
1. Radiated Spurious Emission Measurements at 3 meters by Substitution Method according to ANSI/TIA/EIA-603-D-2010 June 24, 2010:
 2. We are performed all frequency to 10th harmonics from 30 MHz. Measurements above show only up to 3 maximum emissions noted, or would be lesser if no specific emissions from the EUT are recorded (ie: margin > 20 dB from the applicable limit) and considered that's already beyond the background noise floor.
 3. we have done x, y, z planes in EUT and horizontal and vertical polarization in detecting antenna.
 4. All of RB size has been tested for emissions and ERP, with the 1RB configuration observed as the worst case
 5. We are performed 16QAM and QPSK modulations. The worst case data are reported in the table above.

7.9 OCCUPIED BANDWIDTH

Band	Band Width	Frequency (MHz)	Modulation	Resource Block Size	Resource Block Offset	Data (MHz)
Band 12	1.4 MHz	707.5	QPSK	6	0	1.0902
			16-QAM	6	0	1.0944
	3 MHz		QPSK	15	0	2.7154
			16-QAM	15	0	2.7182
	5 MHz		QPSK	25	0	4.4936
			16-QAM	25	0	4.4987
	10 MHz		QPSK	50	0	8.9811
			16-QAM	50	0	8.9448

- Plots of the EUT's Occupied Bandwidth are shown Page 48 ~ 51.

7.10 CONDUCTED SPURIOUS EMISSIONS

Band	Band Width (MHz)	Frequency (MHz)	Modulation	Resource Block Size	Resource Block Offset	Frequency of Maximum Harmonic (GHz)	Maximum Data [dBm]
Band 12	1.4	699.7	QPSK	1	0	3.309206	-32.264
		707.5		1	0	3.160106	-32.408
		715.3		1	0	2.074161	-30.969
	3	700.5		1	0	3.637226	-32.715
		707.5		1	0	2.568179	-32.474
		714.5		1	0	3.068161	-31.915
	5	701.5		1	0	3.032874	-32.272
		707.5		1	0	2.527425	-31.904
		713.5		1	0	3.220243	-32.734
	10	704.0		1	0	3.187441	-32.548
		707.5		1	0	2.947390	-31.909
		711.0		1	0	3.130783	-32.655

- Plots of the EUT's Conducted Spurious Emissions are shown Page 64 ~ 75.

7.10.1 BAND EDGE

- Plots of the EUT's Band Edge are shown Page 52 ~ 63.

7.11 FREQUENCY STABILITY / VARIATION OF AMBIENT TEMPERATURE

7.11.1 FREQUENCY STABILITY (1.4 MHz Band 12 LTE)

- ▣ OPERATING FREQUENCY: 707,500,000 Hz
- ▣ CHANNEL: 23095 (1.4 MHz)
- ▣ REFERENCE VOLTAGE: 3.85 VDC
- ▣ DEVIATION LIMIT: -

Voltage (%)	Power (VDC)	Temp. (°C)	Frequency (Hz)	Frequency Error (Hz)	Deviation (%)	ppm
100%	3.85	+20(Ref)	1879 999 993	0.0	0.000 000	0.000
100%		-30	1879 999 988	-4.7	0.000 000	-0.003
100%		-20	1879 999 989	-4.2	0.000 000	-0.002
100%		-10	1879 999 996	3.5	0.000 000	0.002
100%		0	1879 999 997	3.7	0.000 000	0.002
100%		+10	1879 999 996	3.1	0.000 000	0.002
100%		+30	1879 999 989	-3.6	0.000 000	-0.002
100%		+40	1879 999 990	-3.4	0.000 000	-0.002
100%		+50	1879 999 989	-4.0	0.000 000	-0.002
Batt. Endpoint		3.27	+20	1879 999 997	4.2	0.000 000

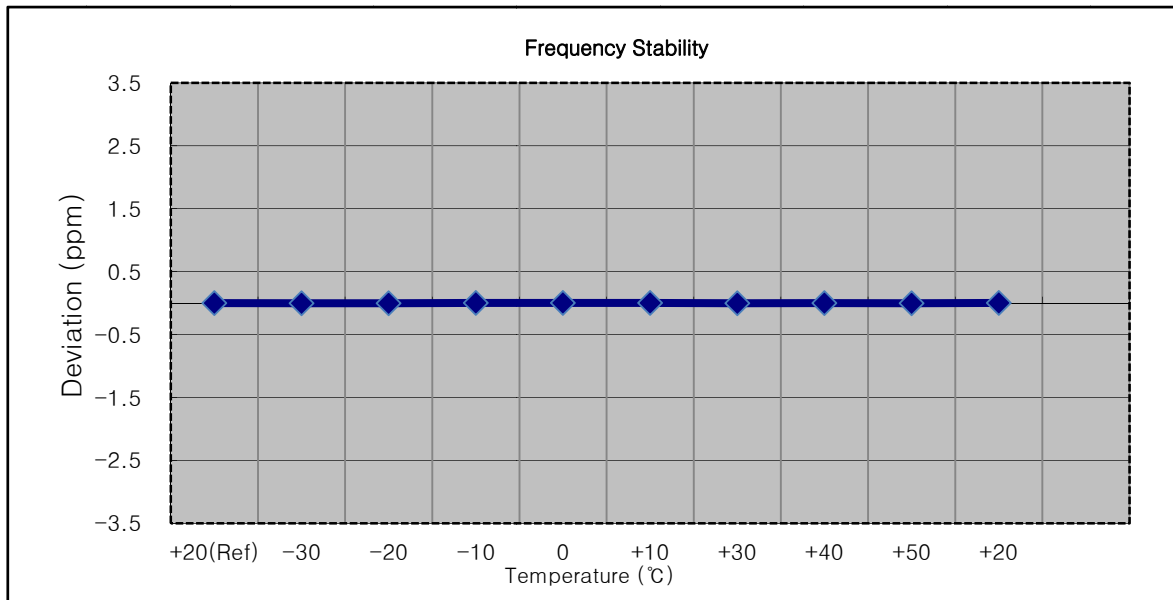

7.11.2 FREQUENCY STABILITY (3 MHz Band 12 LTE)

- ▣ OPERATING FREQUENCY: 707,500,000 Hz
- ▣ CHANNEL: 23095 (3 MHz)
- ▣ REFERENCE VOLTAGE: 3.85 VDC
- ▣ DEVIATION LIMIT: -

Voltage (%)	Power (VDC)	Temp. (°C)	Frequency (Hz)	Frequency Error (Hz)	Deviation (%)	ppm
100%	3.85	+20(Ref)	1879 999 995	0.0	0.000 000	0.000
100%		-30	1879 999 998	3.0	0.000 000	0.002
100%		-20	1879 999 998	3.1	0.000 000	0.002
100%		-10	1879 999 998	3.2	0.000 000	0.002
100%		0	1879 999 990	-4.3	0.000 000	-0.002
100%		+10	1879 999 998	3.9	0.000 000	0.002
100%		+30	1879 999 992	-3.0	0.000 000	-0.002
100%		+40	1879 999 998	3.1	0.000 000	0.002
100%		+50	1879 999 991	-3.4	0.000 000	-0.002
Batt. Endpoint	3.27	+20	1880 000 001	6.5	0.000 000	0.003

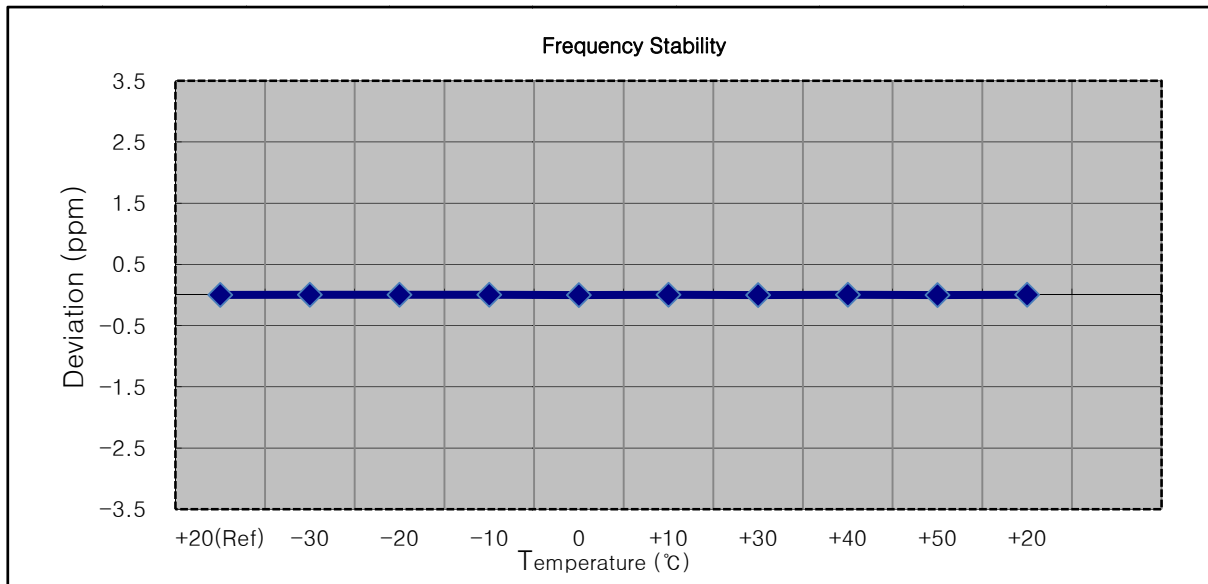

7.11.3 FREQUENCY STABILITY (5 MHz Band 12 LTE)

- ▣ OPERATING FREQUENCY: 707,500,000 Hz
- ▣ CHANNEL: 23095 (5 MHz)
- ▣ REFERENCE VOLTAGE: 3.85 VDC
- ▣ DEVIATION LIMIT: -

Voltage (%)	Power (VDC)	Temp. (°C)	Frequency (Hz)	Frequency Error (Hz)	Deviation (%)	ppm
100%	3.85	+20(Ref)	1879 999 995	0.0	0.000 000	0.000
100%		-30	1879 999 992	-2.9	0.000 000	-0.002
100%		-20	1879 999 991	-4.4	0.000 000	-0.002
100%		-10	1879 999 999	3.4	0.000 000	0.002
100%		0	1879 999 993	-2.7	0.000 000	-0.001
100%		+10	1879 999 993	-2.2	0.000 000	-0.001
100%		+30	1879 999 991	-4.2	0.000 000	-0.002
100%		+40	1879 999 998	2.8	0.000 000	0.001
100%		+50	1879 999 992	-3.1	0.000 000	-0.002
Batt. Endpoint		3.27	+20	1879 999 990	-5.1	0.000 000

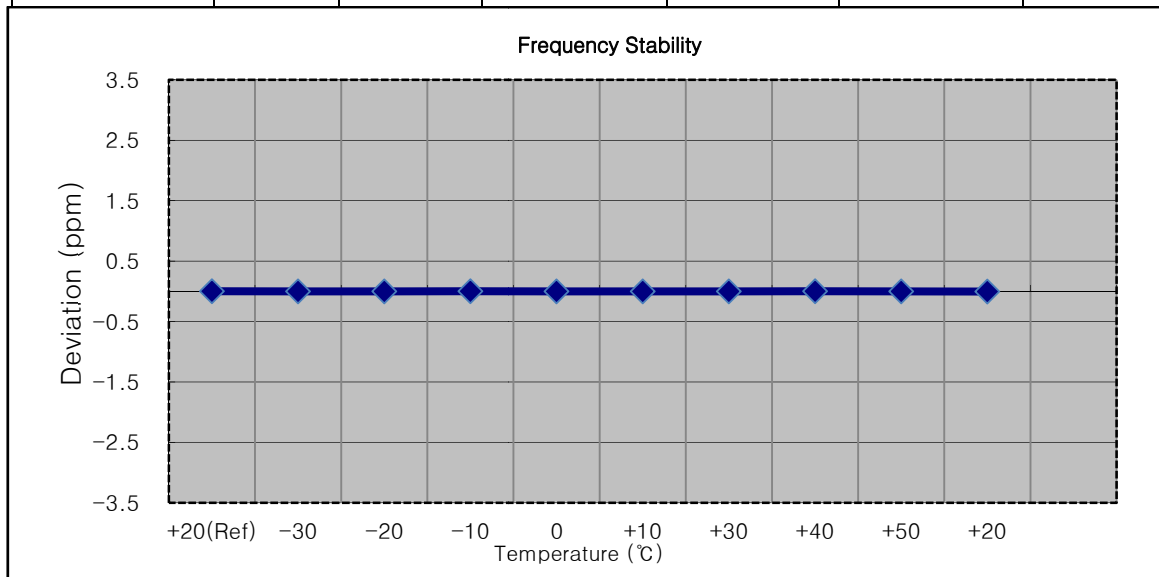

7.11.4 FREQUENCY STABILITY (10 MHz Band 12 LTE)

- ▣ OPERATING FREQUENCY: 707,500,000 Hz
- ▣ CHANNEL: 23095 (10 MHz)
- ▣ REFERENCE VOLTAGE: 3.85 VDC
- ▣ DEVIATION LIMIT: -

Voltage (%)	Power (VDC)	Temp. (°C)	Frequency (Hz)	Frequency Error (Hz)	Deviation (%)	ppm
100%	3.85	+20(Ref)	1879 999 994	0.0	0.000 000	0.000
100%		-30	1879 999 990	-3.5	0.000 000	-0.002
100%		-20	1879 999 997	3.3	0.000 000	0.002
100%		-10	1879 999 991	-3.3	0.000 000	-0.002
100%		0	1879 999 997	3.1	0.000 000	0.002
100%		+10	1879 999 996	2.1	0.000 000	0.001
100%		+30	1879 999 990	-4.2	0.000 000	-0.002
100%		+40	1879 999 990	-3.5	0.000 000	-0.002
100%		+50	1879 999 991	-3.3	0.000 000	-0.002
Batt. Endpoint	3.27	+20	1879 999 996	2.1	0.000 000	0.001

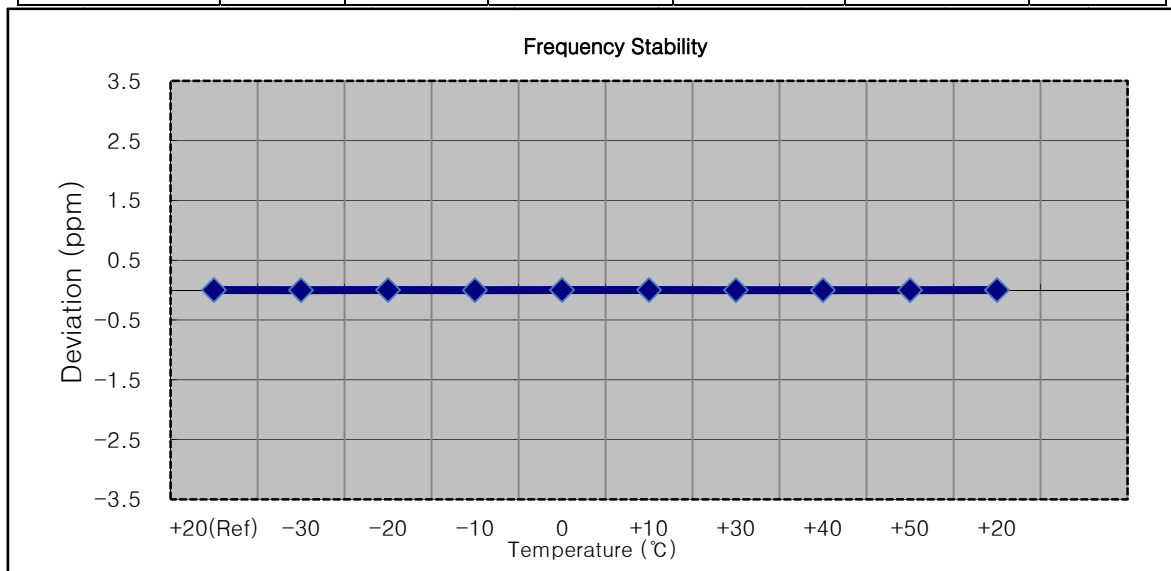

8. TEST PLOTS

BAND 12. Occupied Bandwidth Plot (1.4M BW Ch.23095 QPSK_RB6_0)

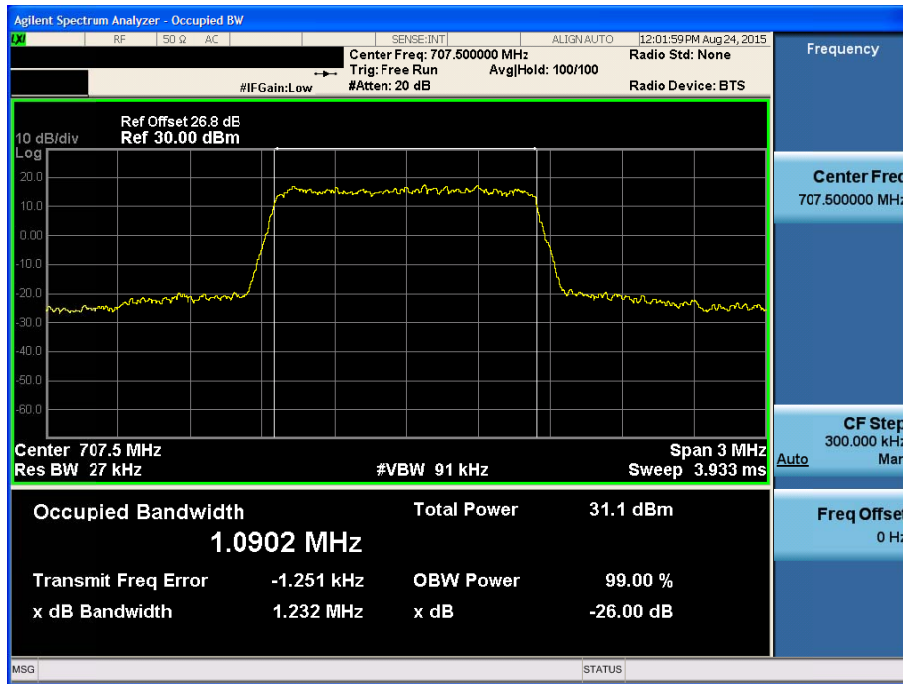

BAND 12. Occupied Bandwidth Plot (1.4M BW Ch.23095 16QAM_RB6_0)

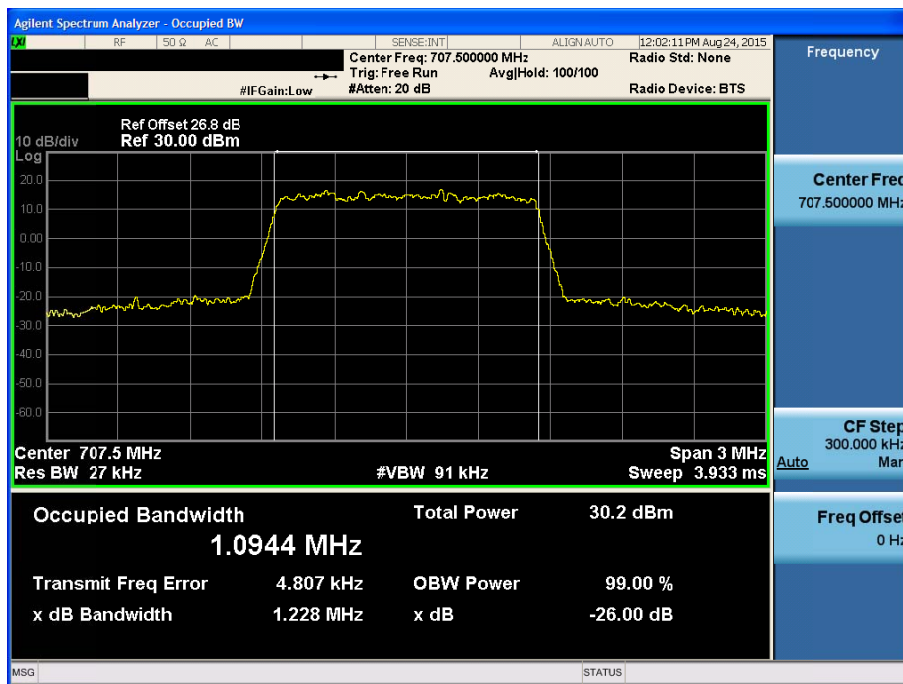

BAND 12. Occupied Bandwidth Plot (3M BW Ch.23095 QPSK_RB15_0)

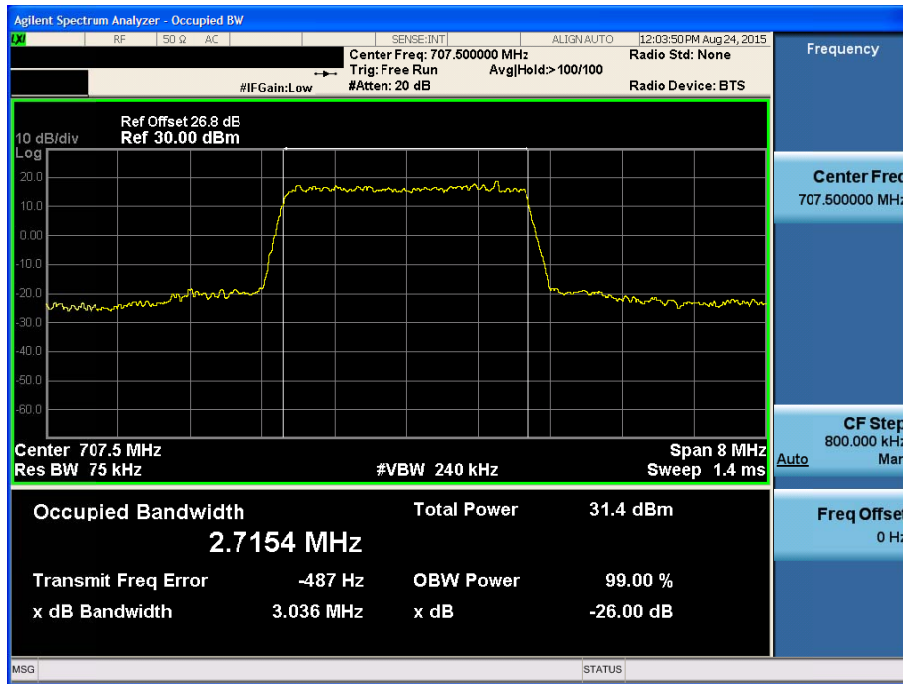

BAND 12. Occupied Bandwidth Plot (3M BW Ch.23095 16QAM_RB15_0)

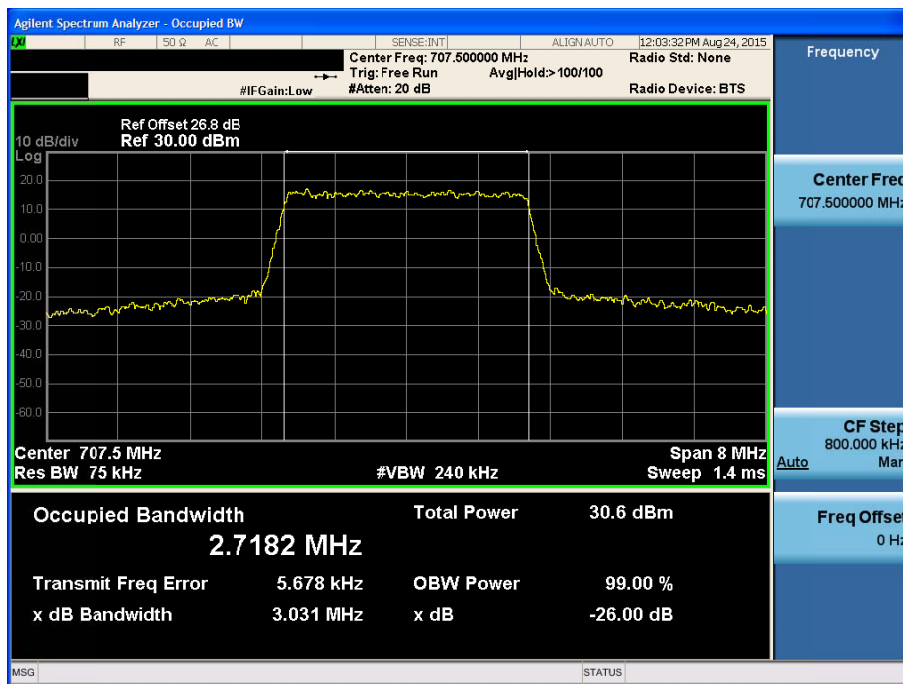

BAND 12. Occupied Bandwidth Plot (5M BW Ch.23095 QPSK_RB25_0)

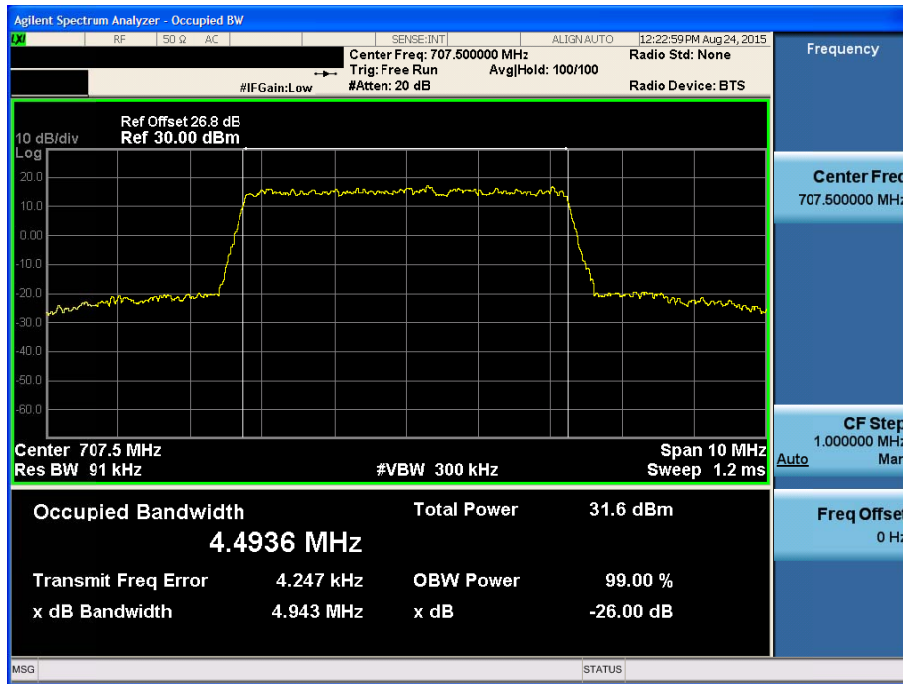

BAND 12. Occupied Bandwidth Plot (5M BW Ch.23095 16QAM_RB25_0)

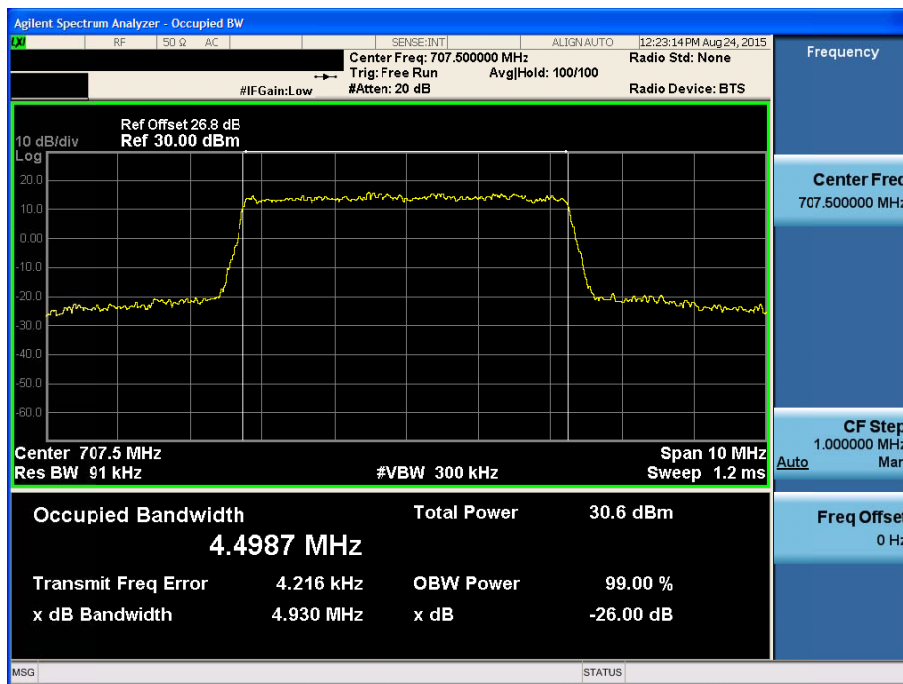

BAND 12. Occupied Bandwidth Plot (10M BW Ch.23095 QPSK_RB50_0)

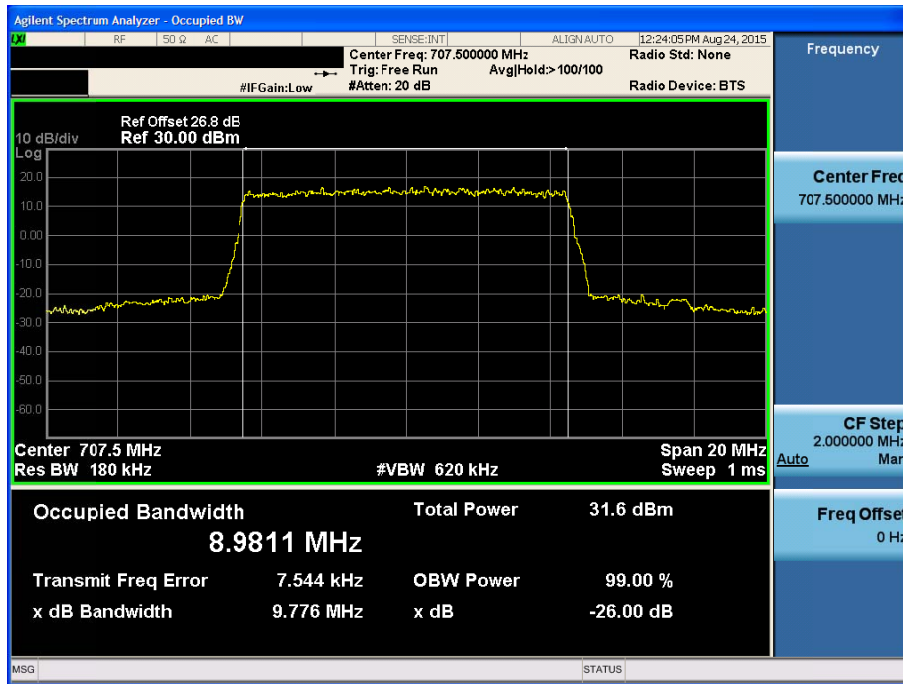

BAND 12. Occupied Bandwidth Plot (10M BW Ch.23095 16QAM_RB50_0)

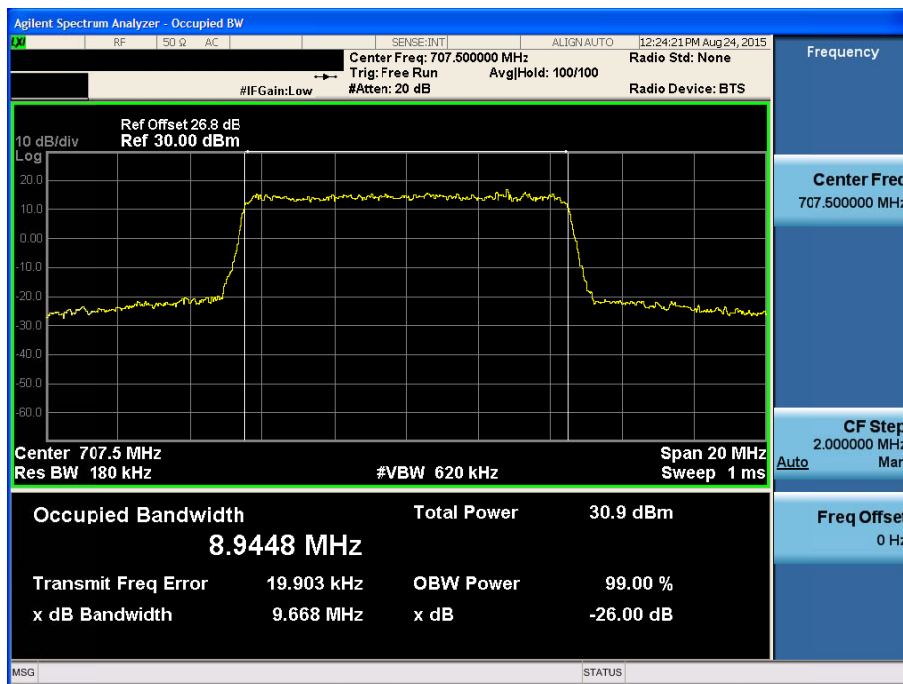

BAND 12. Lower Band Edge Plot (1.4M BW Ch.23017 QPSK_RB1_Offset 0)

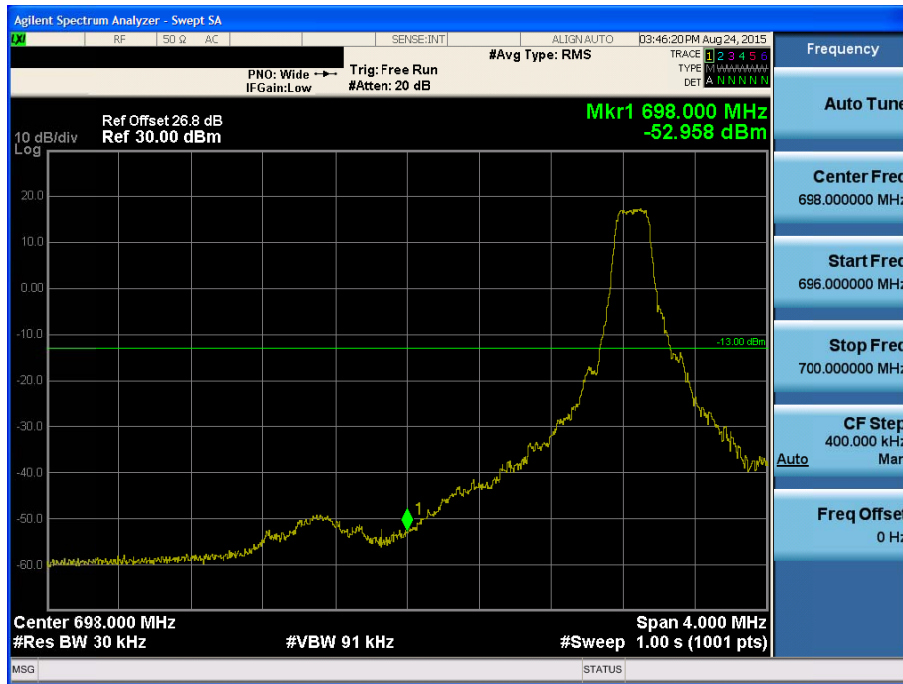

BAND 12. Lower Band Edge Plot (1.4M BW Ch.23017 QPSK_RB6_Offset 0)

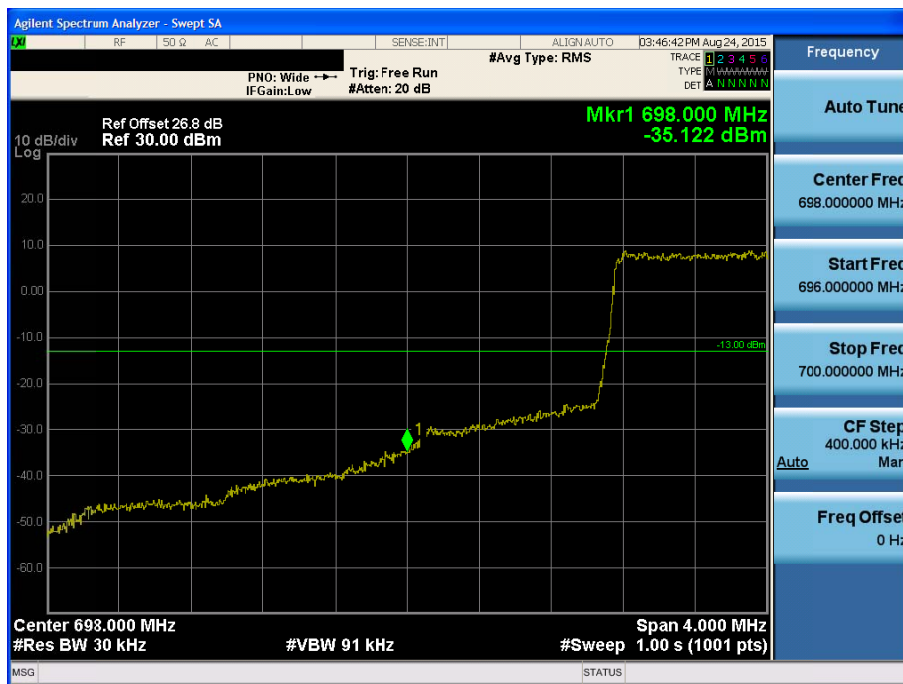

BAND 12. Lower Extended Band Edge Plot (1.4M BW Ch.23017 QPSK_RB6_0)



BAND 12. Lower Band Edge Plot (3M BW Ch.23025 QPSK_RB1_Offset 0)

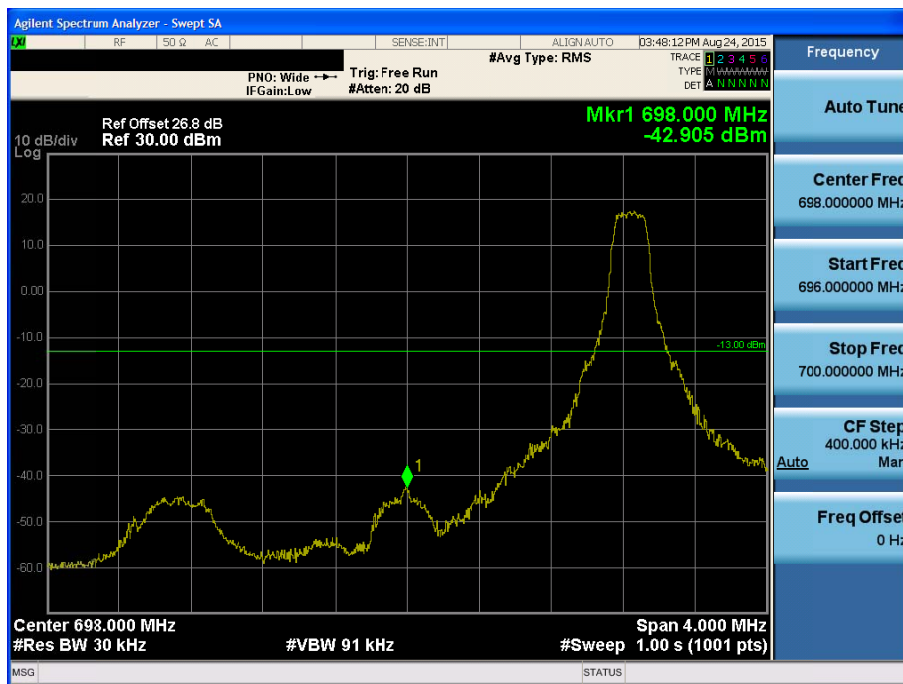

BAND 12. Lower Band Edge Plot (3M BW Ch.23025 QPSK_RB15_Offset 0)

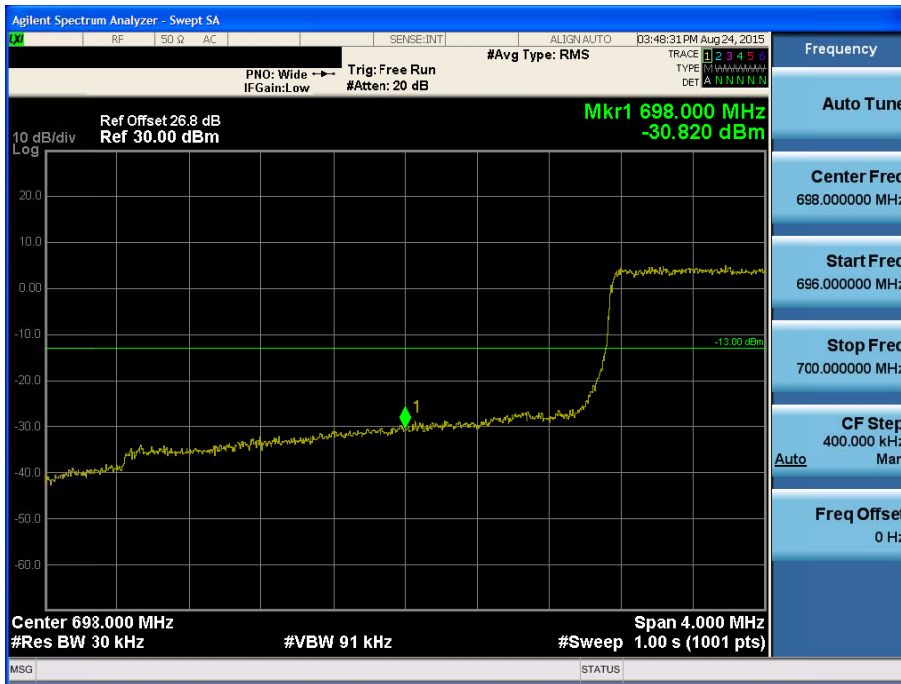

BAND 12. Lower Extended Band Edge Plot (3M BW Ch.23025 QPSK_RB15_0)

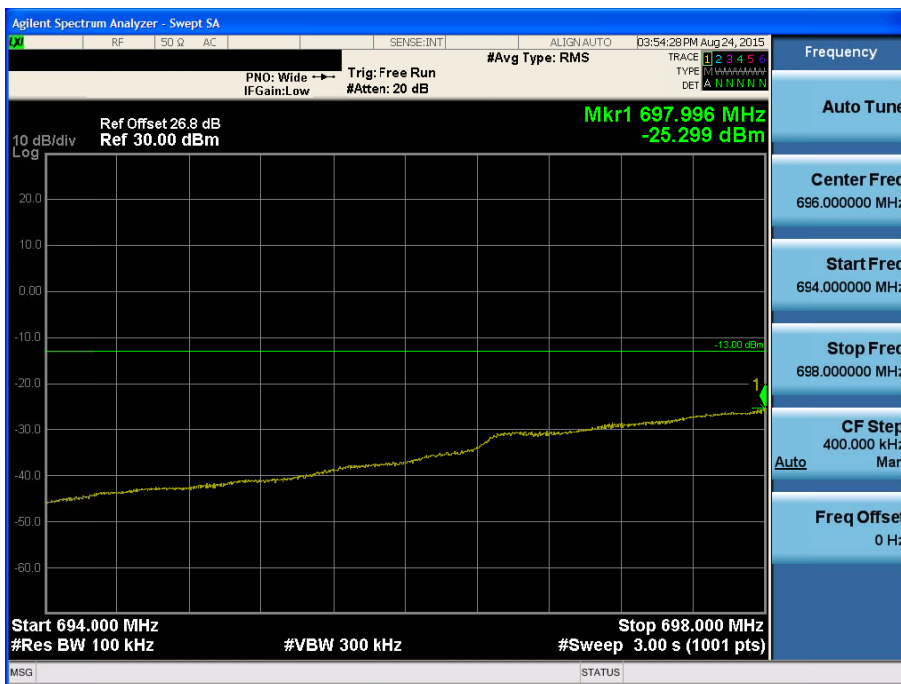

BAND 12. Lower Band Edge Plot (5M BW Ch.23035 QPSK_RB1_Offset 0)

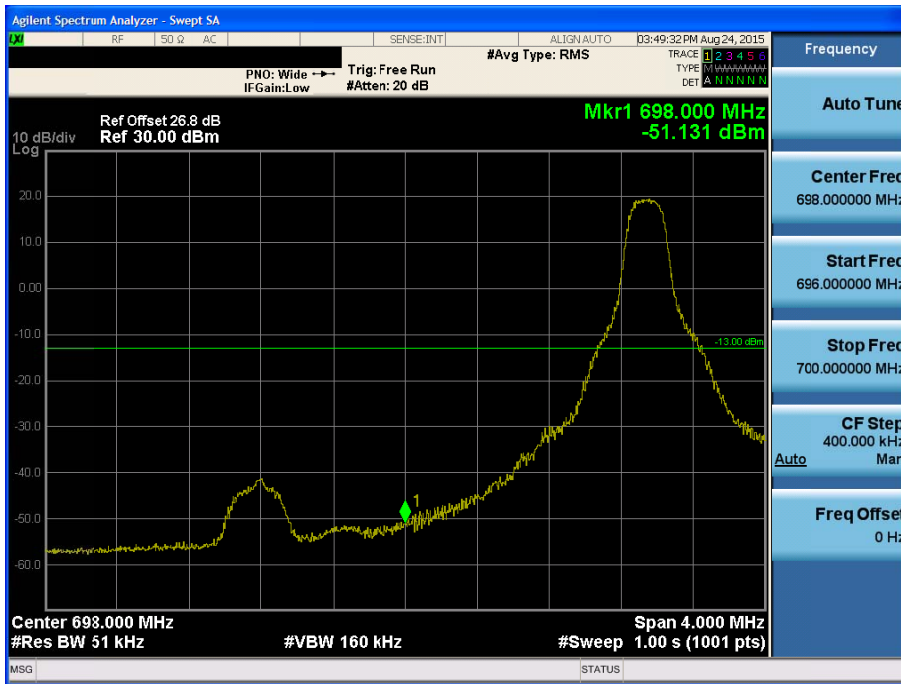

BAND 12. Lower Band Edge Plot (5M BW Ch.23035 QPSK_RB25_Offset 0)

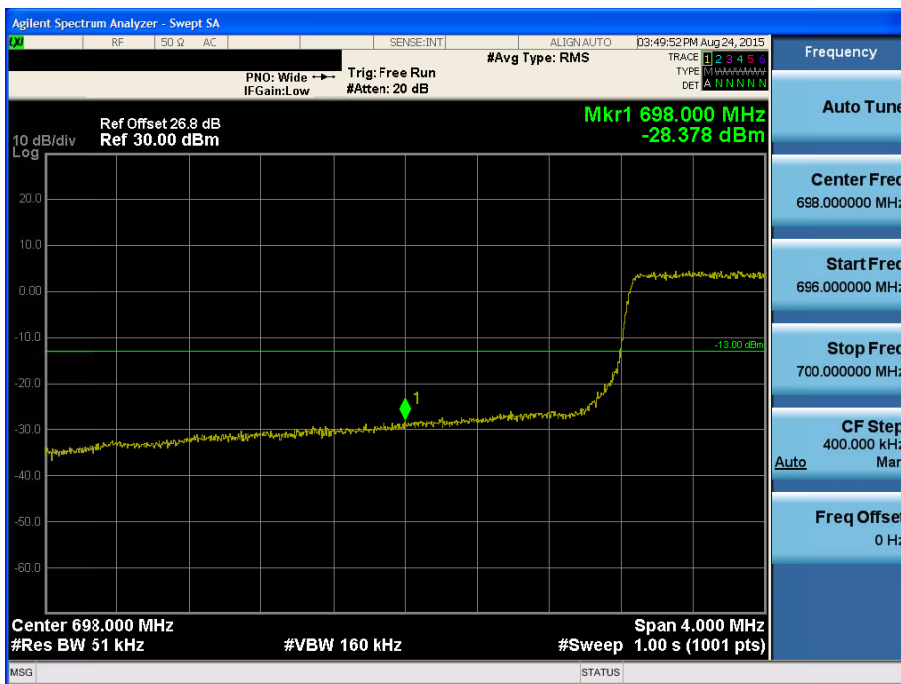

BAND 12. Lower Extended Band Edge Plot (5M BW Ch.23035 QPSK_RB25_0)

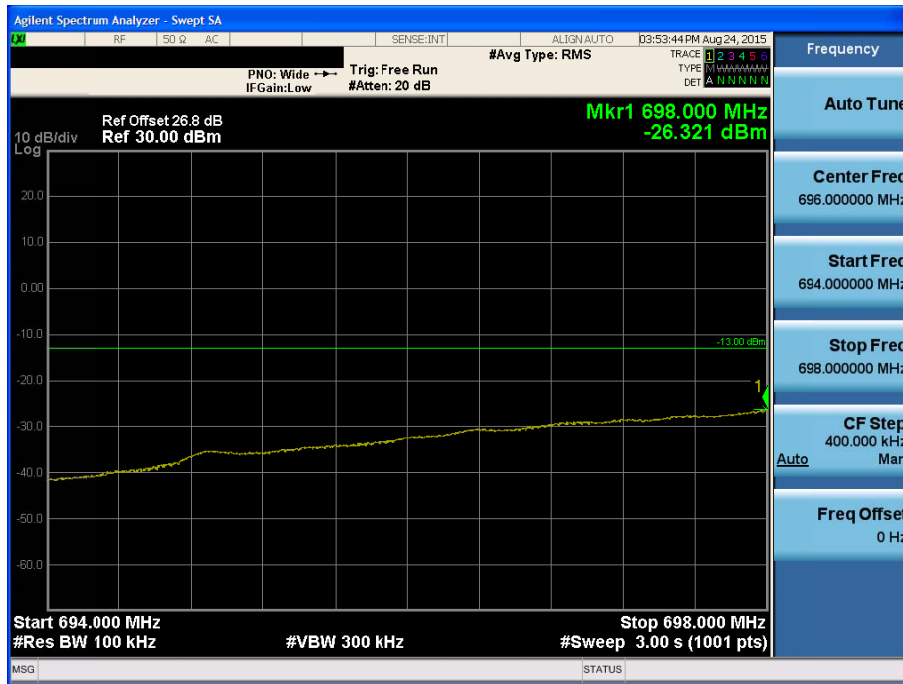

BAND 12. Lower Band Edge Plot (10M BW Ch.23060 QPSK_RB1_Offset 0)

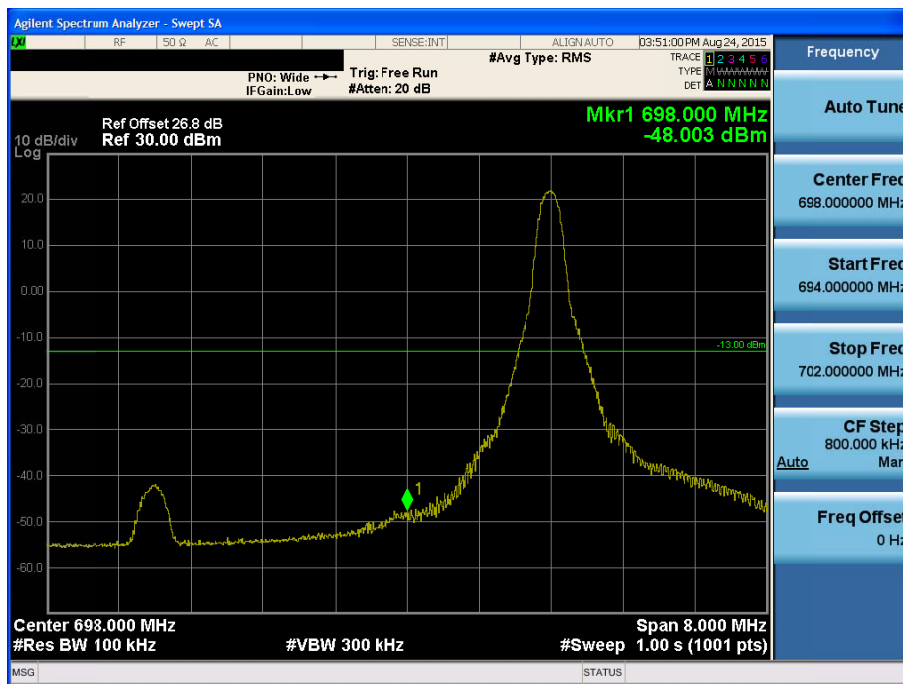

BAND 12. Lower Band Edge Plot (10M BW Ch.23060 QPSK_RB50_Offset 0)

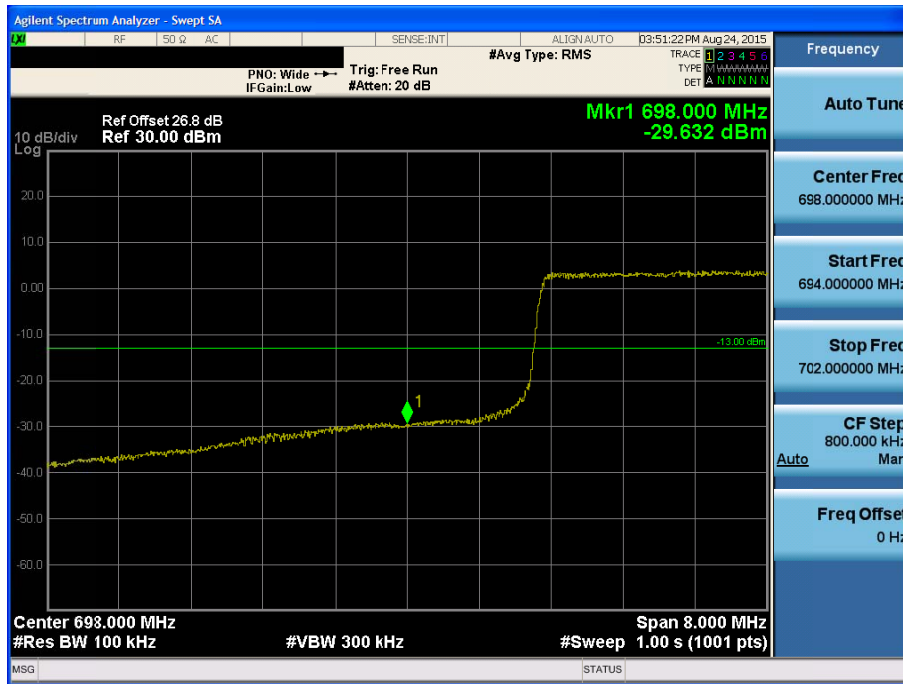

BAND 12. Lower Extended Band Edge Plot (10M BW Ch.23060 QPSK_RB50_0)

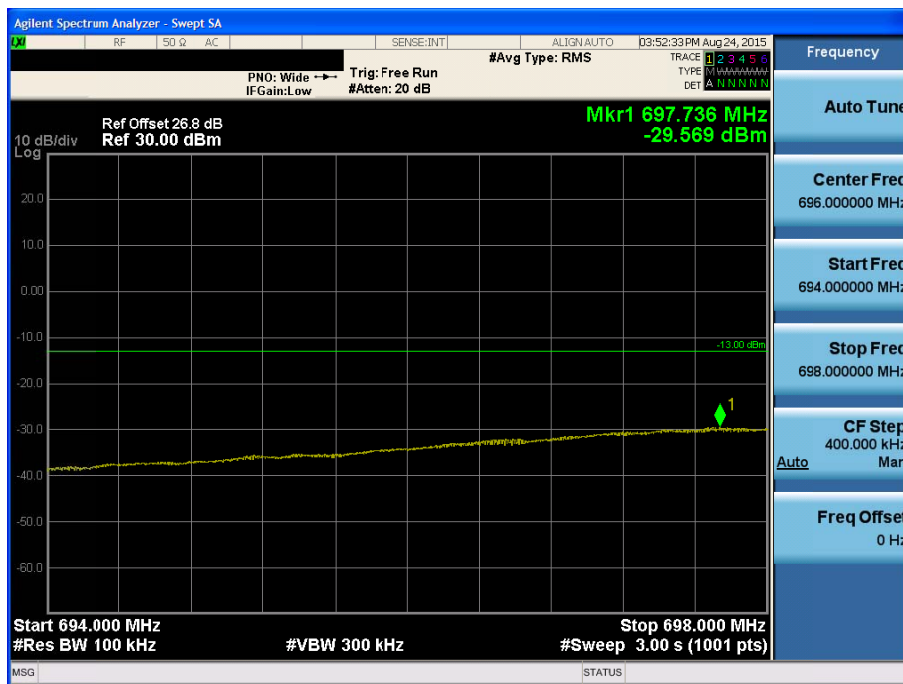

BAND 12. Upper Band Edge Plot (1.4M BW Ch.23173 QPSK_RB1_Offset 5)

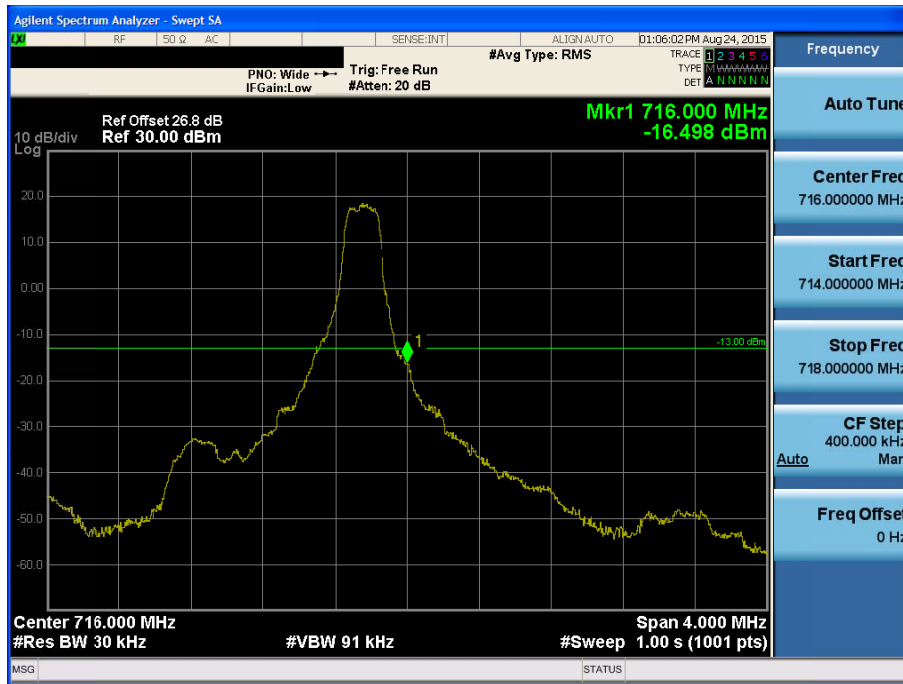

BAND 12. Upper Band Edge Plot (1.4M BW Ch.23173 QPSK_RB6_Offset 0)



BAND 12. Upper Extended Band Edge Plot (1.4M BW Ch.23173 QPSK_RB6_0)



BAND 12. Upper Band Edge Plot (3M BW Ch.23165 QPSK_RB1_Offset 14)

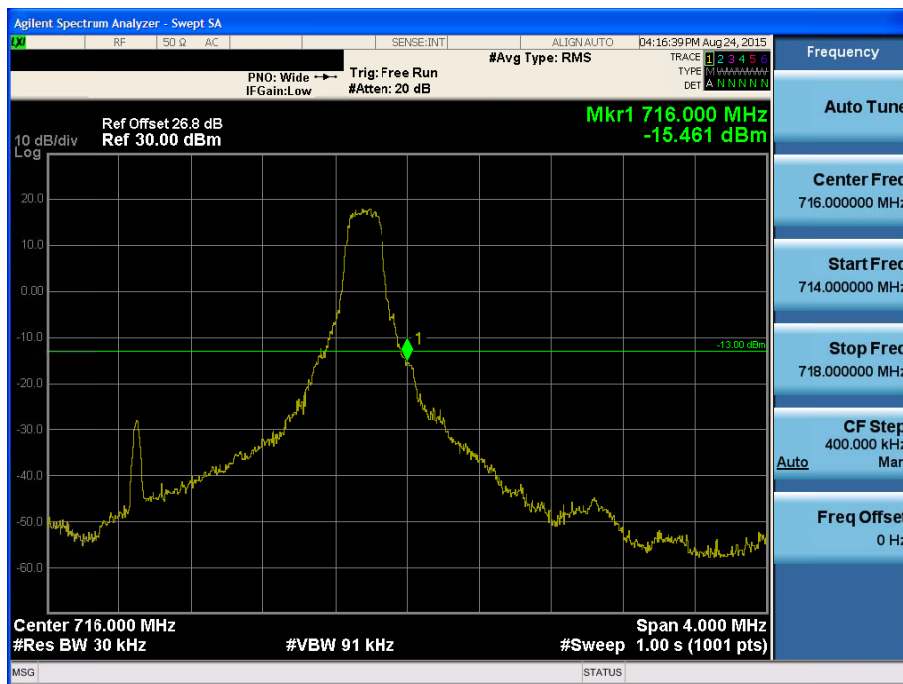

BAND 12. Upper Band Edge Plot (3M BW Ch.23165 QPSK_RB15_Offset 0)

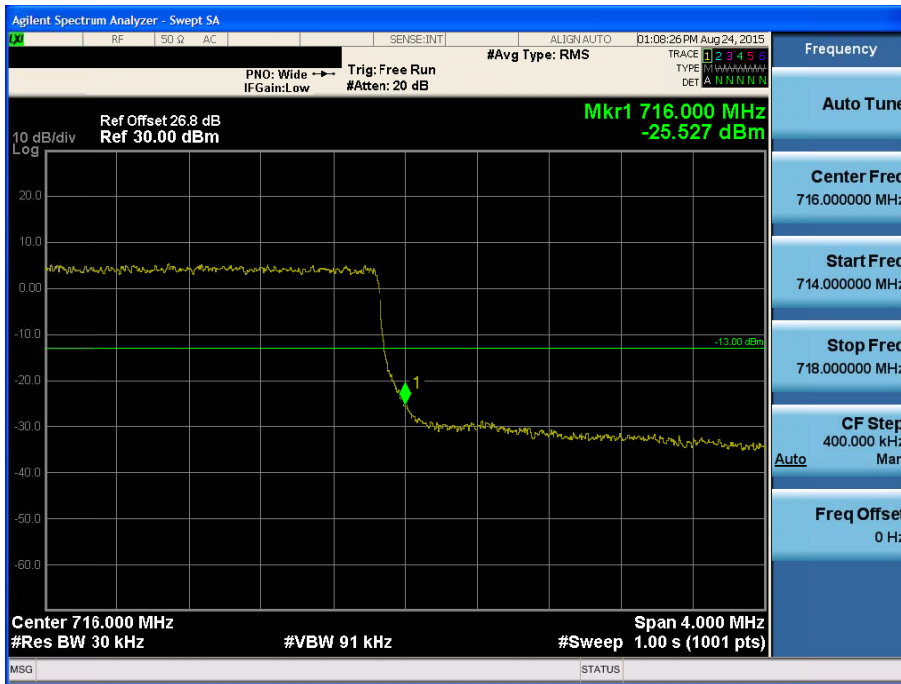

BAND 12. Upper Extended Band Edge Plot (3M BW Ch.23165 QPSK_RB15_0)

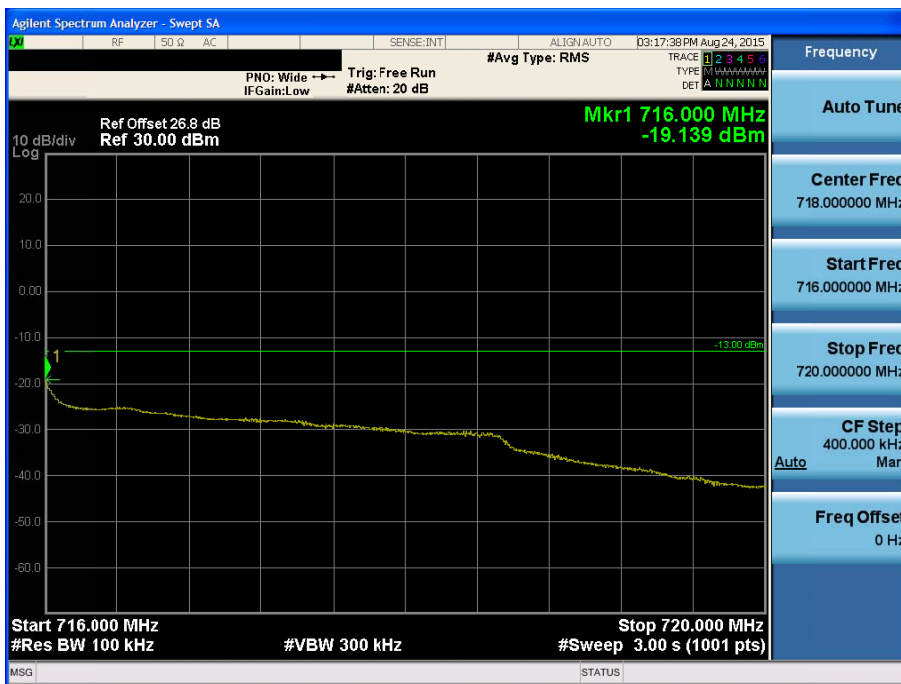

BAND 12. Upper Band Edge Plot (5M BW Ch.23155 QPSK_RB1_Offset 24)

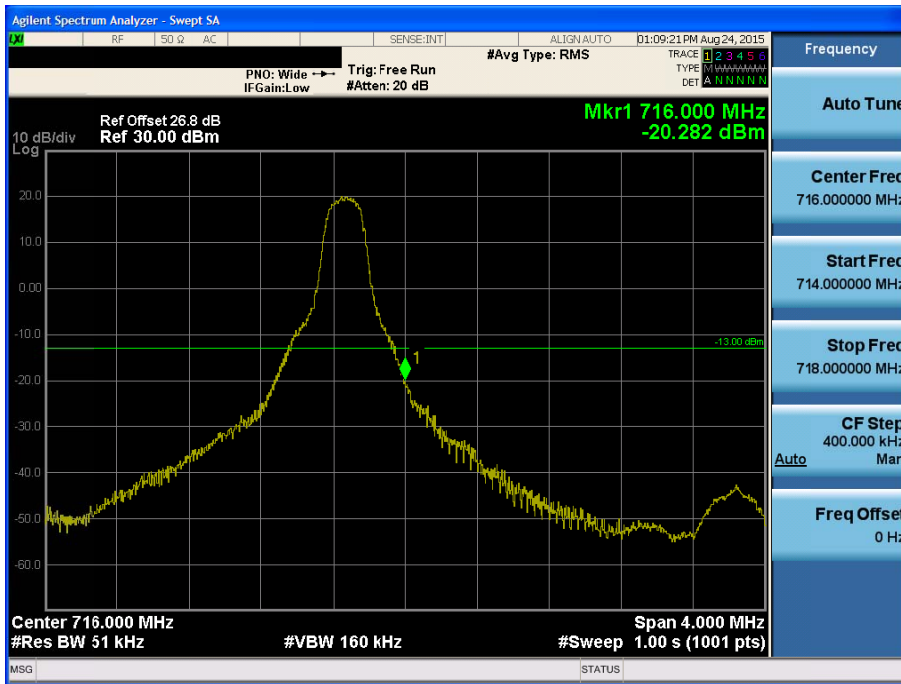

BAND 12. Upper Band Edge Plot (5M BW Ch.23155 QPSK_RB25_Offset 0)

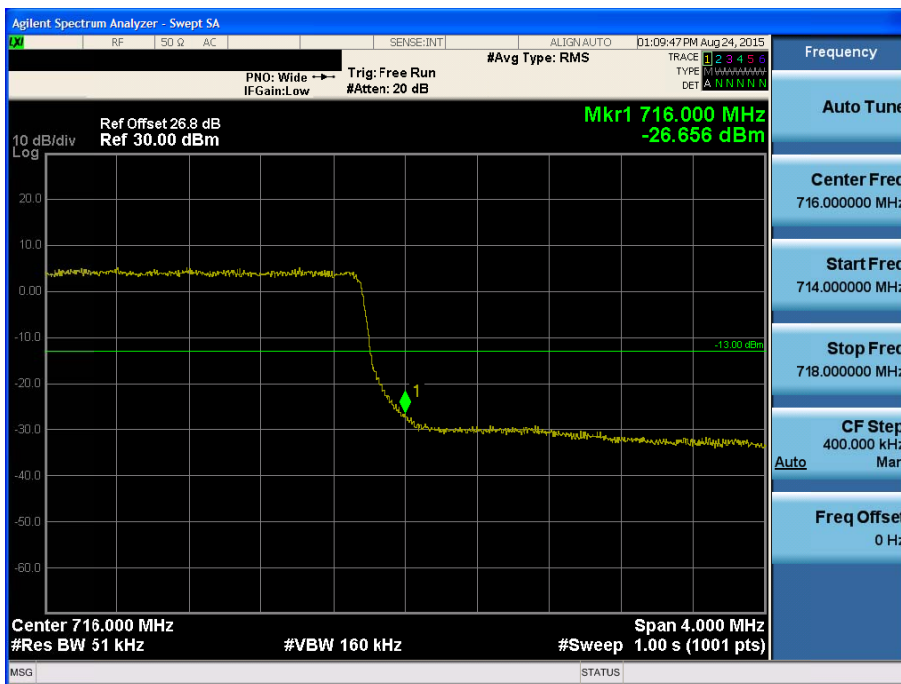

BAND 12. Upper Extended Band Edge Plot (5M BW Ch.23155 QPSK_RB25_0)



BAND 12. Upper Band Edge Plot (10M BW Ch.23130 QPSK_RB1_Offset 49)

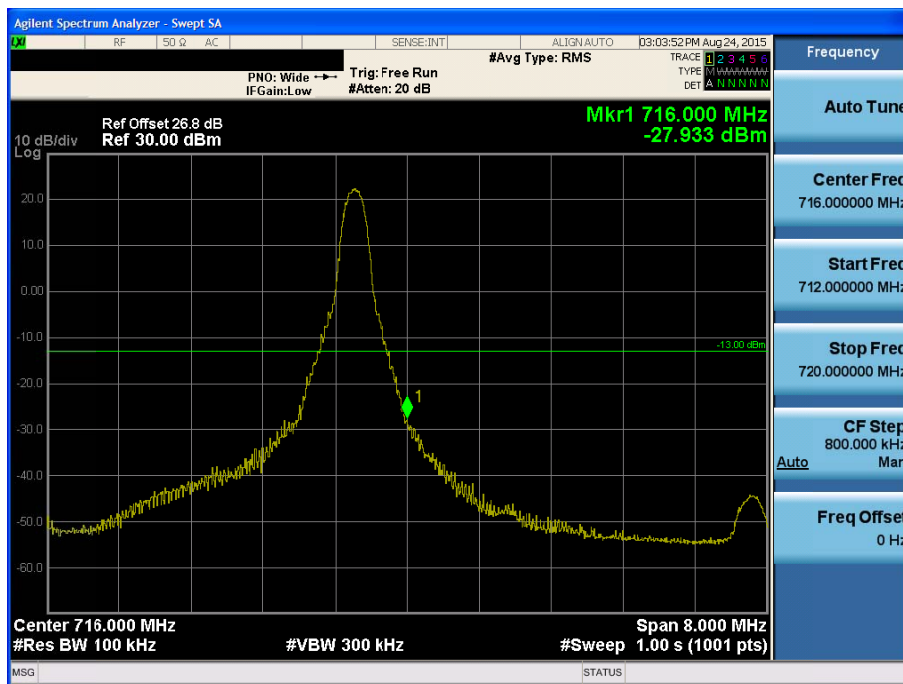

BAND 12. Upper Band Edge Plot (10M BW Ch.23130 QPSK_RB50_Offset 0)



BAND 12. Upper Extended Band Edge Plot (10M BW Ch.23130 QPSK_RB50_0)

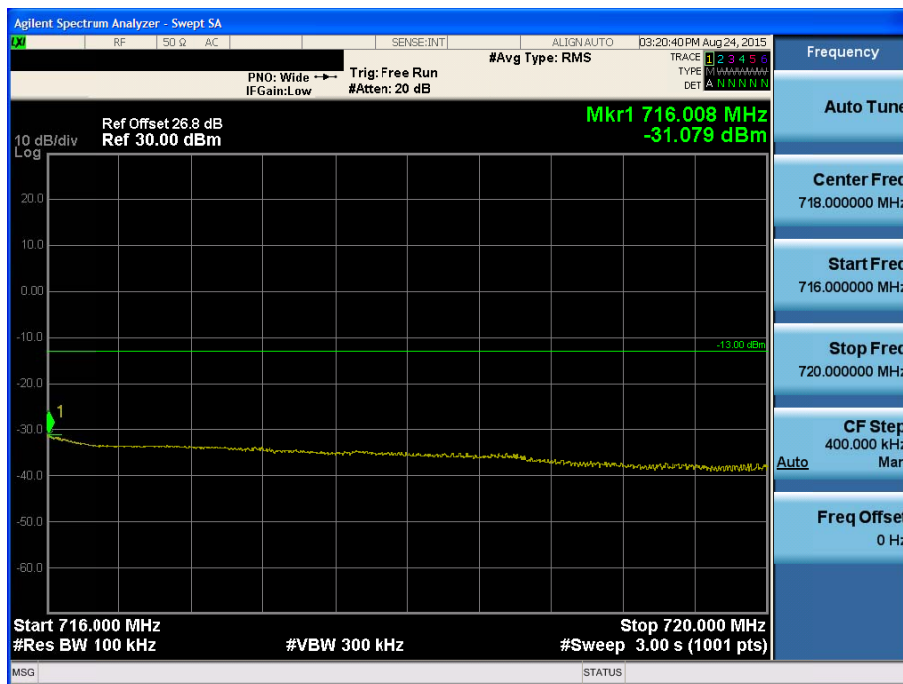

BAND 12. Conducted Spurious Plot _1 (23017ch_1.4MHz_QPSK_RB 1_0)

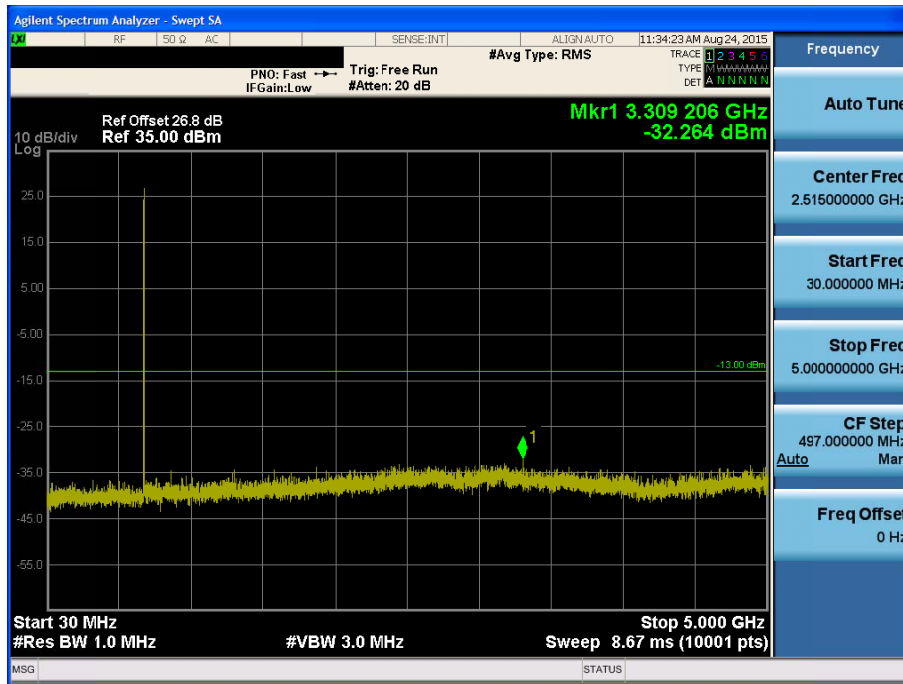

BAND 12. Conducted Spurious Plot _2 (23017ch_1.4MHz_QPSK_RB 1_0)

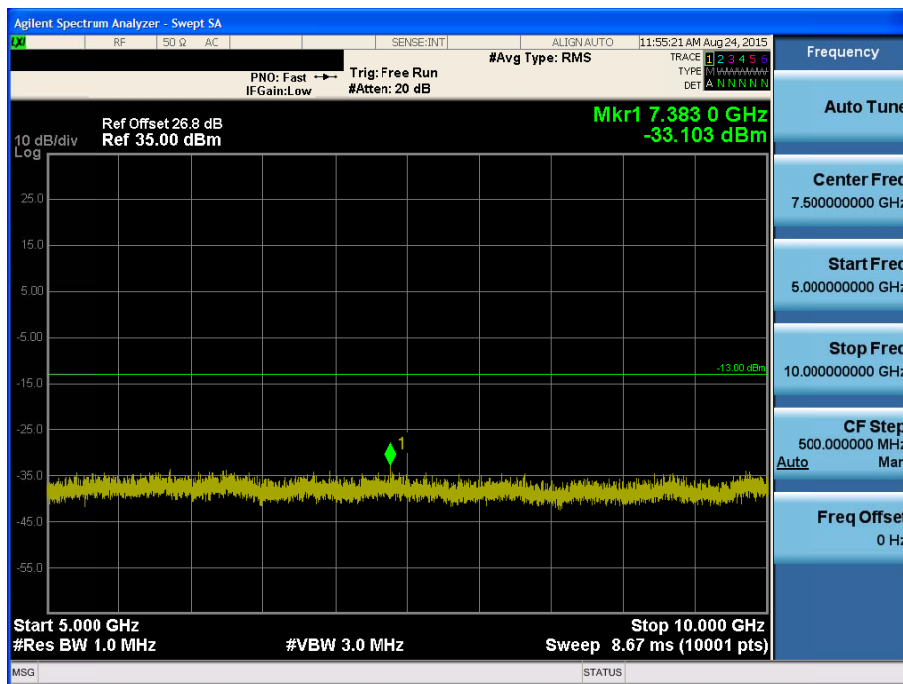

BAND 12. Conducted Spurious Plot _1 (23095ch_1.4MHz_QPSK_RB 1_0)

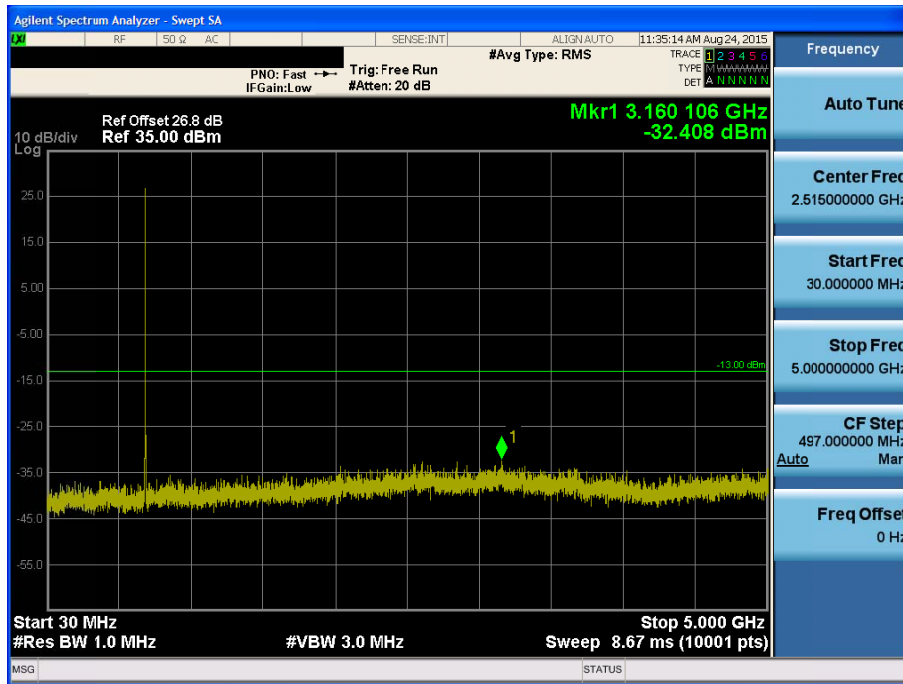

BAND 12. Conducted Spurious Plot _2 (23095ch_1.4MHz_QPSK_RB 1_0)

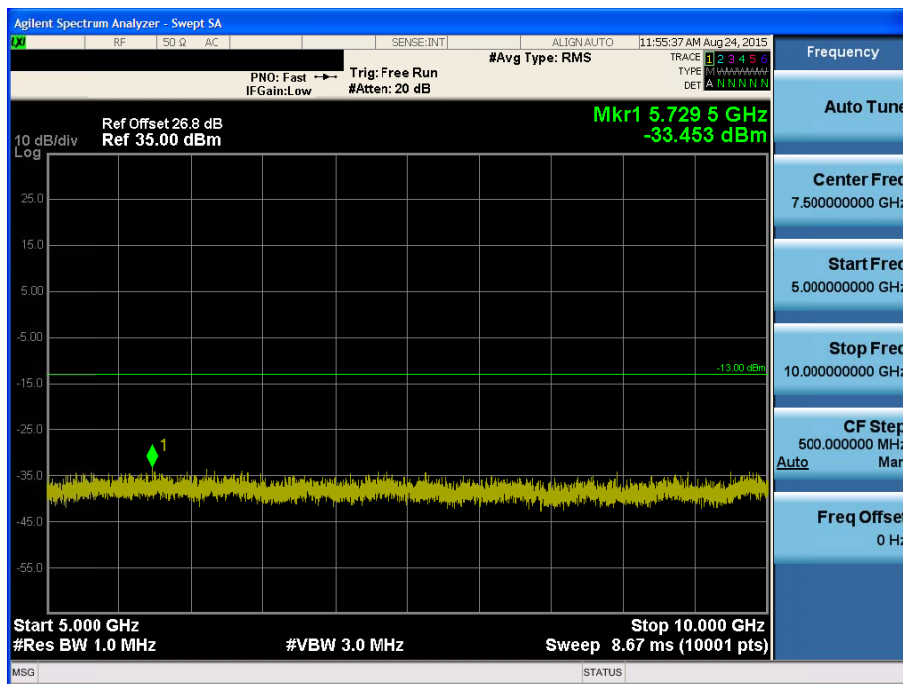

BAND 12. Conducted Spurious Plot _1 (23173ch_1.4MHz_QPSK_RB 1_0)

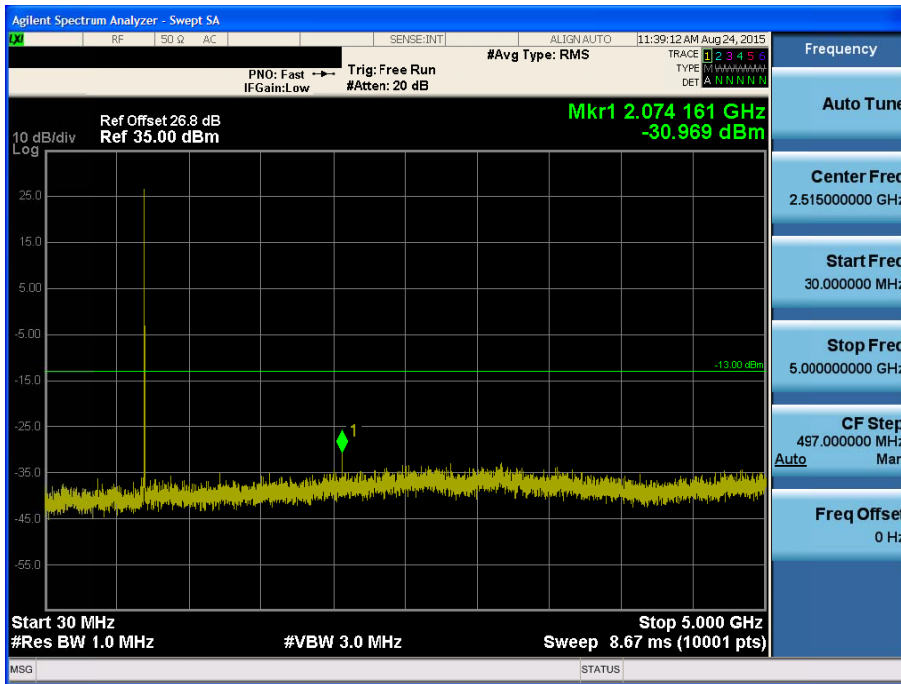

BAND 12. Conducted Spurious Plot _2 (23173ch_1.4MHz_QPSK_RB 1_0)

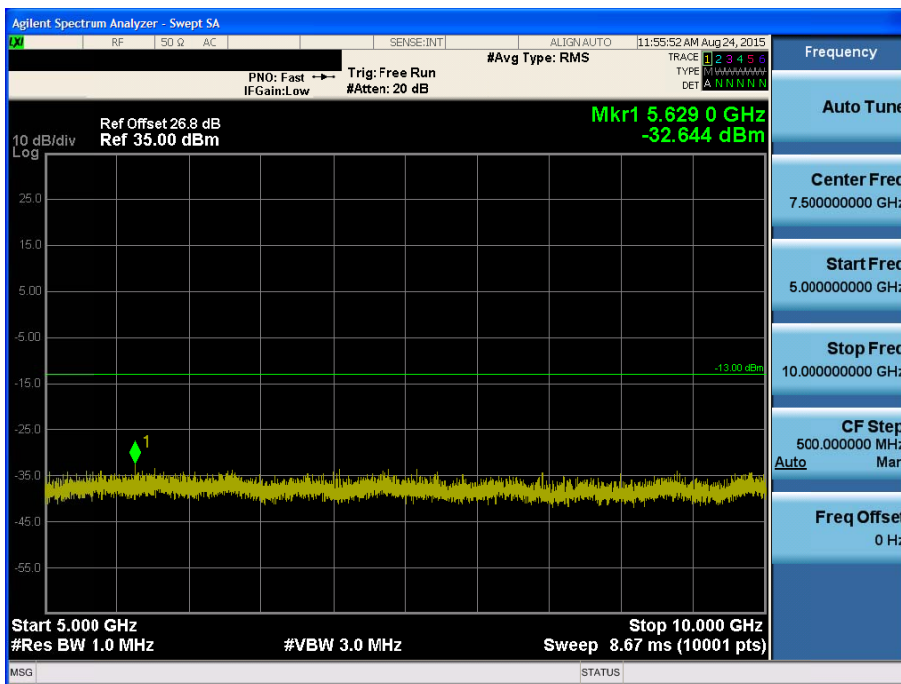

BAND 12. Conducted Spurious Plot_1 (23025ch_3MHz_QPSK_RB 1_0)

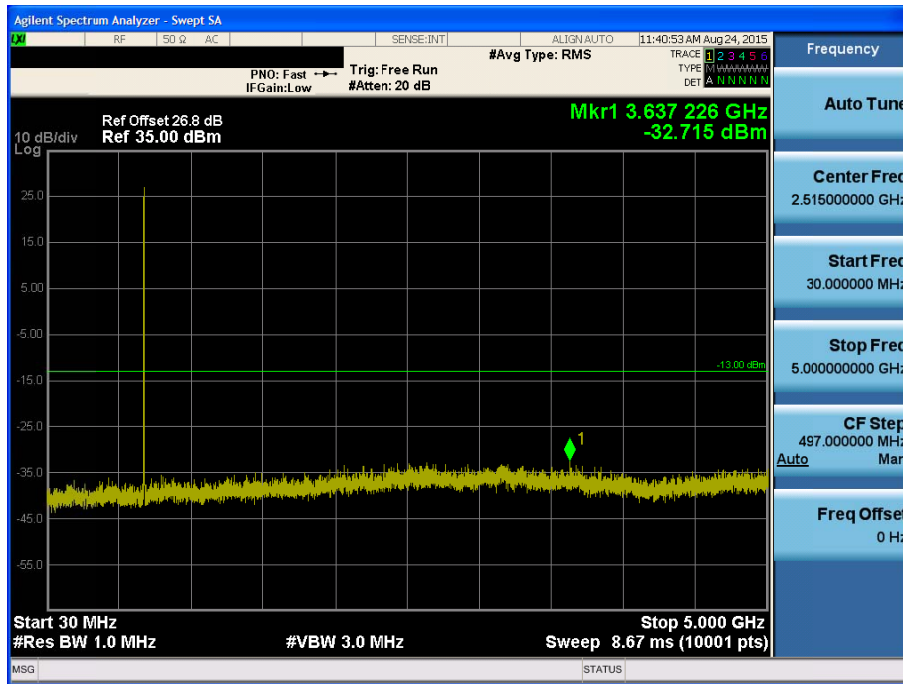

BAND 12. Conducted Spurious Plot_2 (23025ch_3MHz_QPSK_RB 1_0)

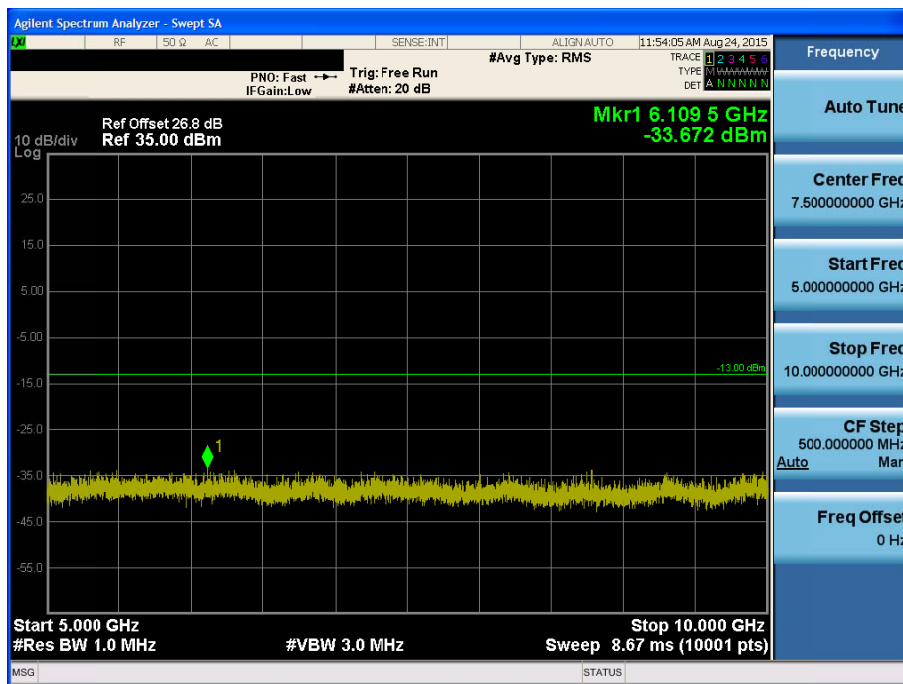

BAND 12. Conducted Spurious Plot _1 (23095ch_3MHz_QPSK_RB 1_0)

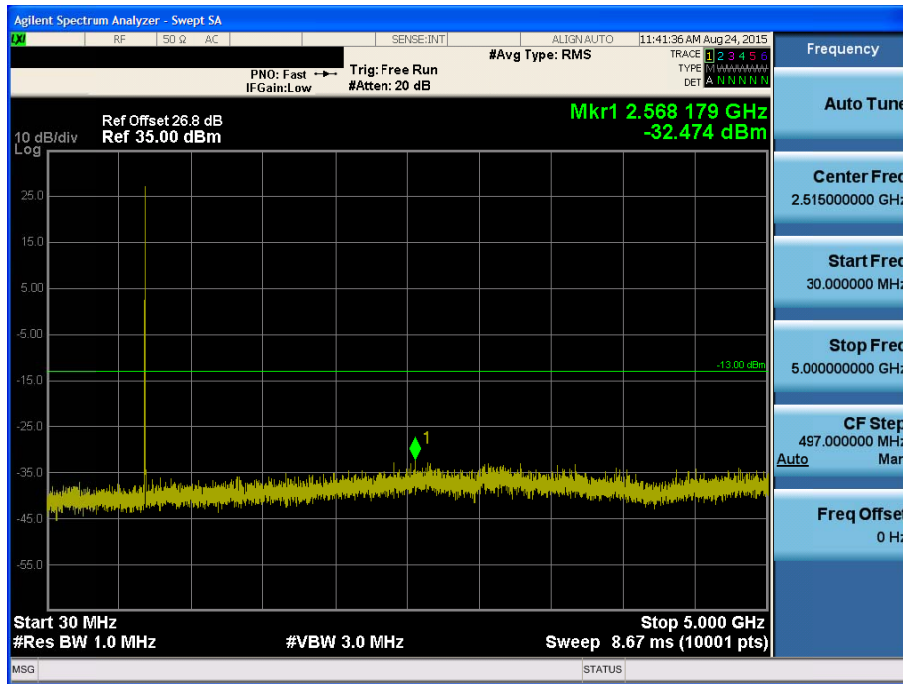

BAND 12. Conducted Spurious Plot _2 (23095ch_3MHz_QPSK_RB 1_0)

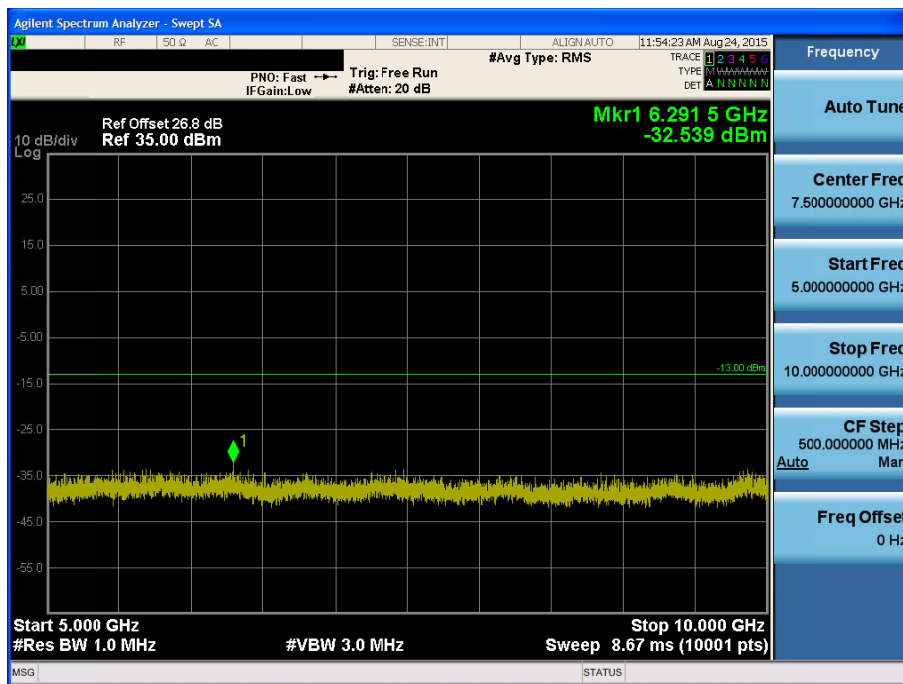

BAND 12. Conducted Spurious Plot _1 (23165ch_3MHz_QPSK_RB 1_0)

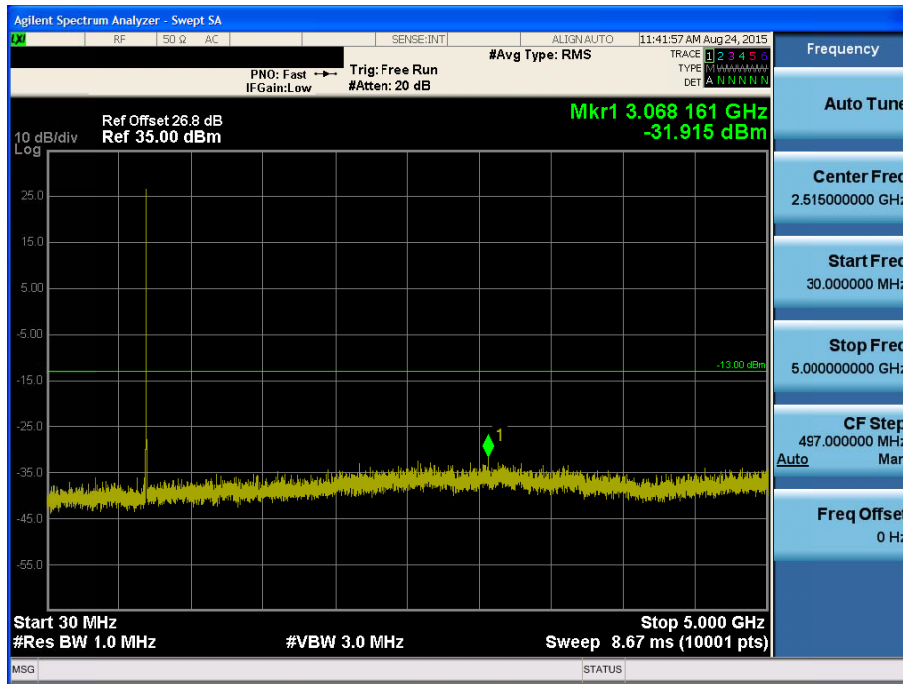

BAND 12. Conducted Spurious Plot _2 (23165ch_3MHz_QPSK_RB 1_0)

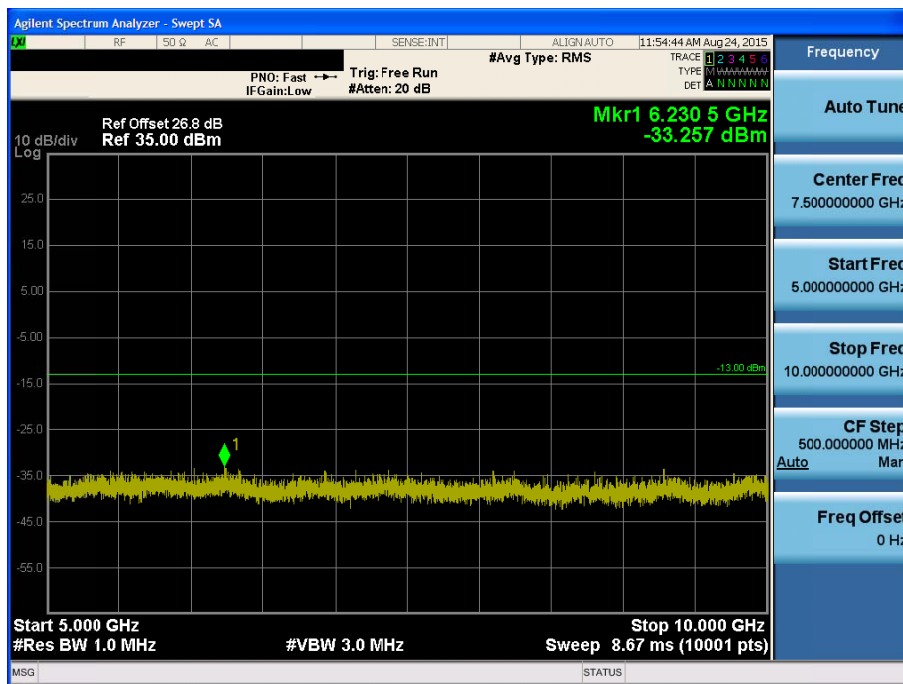

BAND 12. Conducted Spurious Plot _1 (23035ch_5MHz_QPSK_RB 1_0)

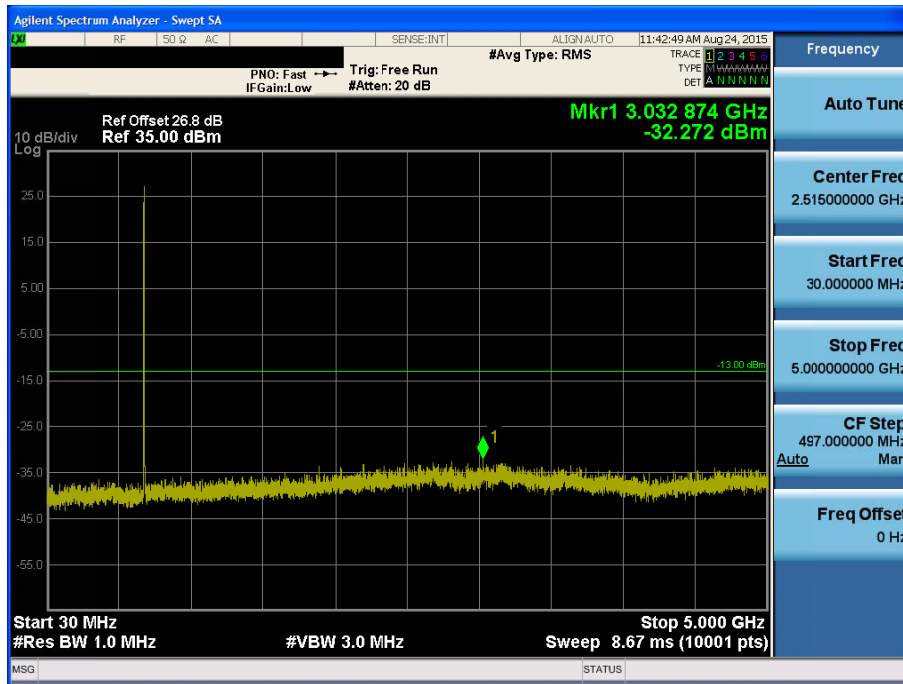

BAND 12. Conducted Spurious Plot _2 (23035ch_5MHz_QPSK_RB 1_0)

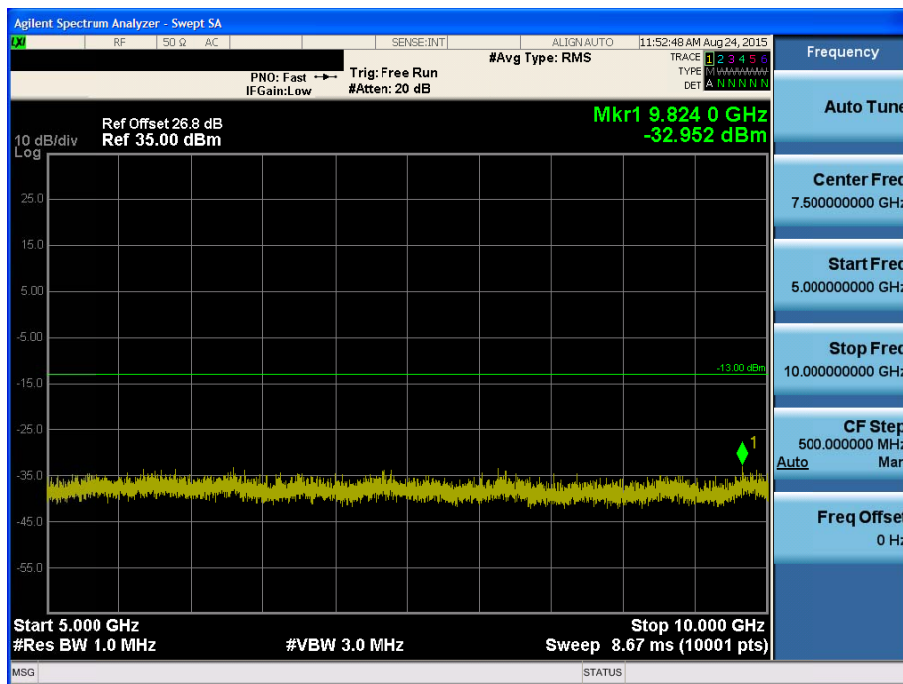

BAND 12. Conducted Spurious Plot _1 (23095ch_5MHz_QPSK_RB 1_0)

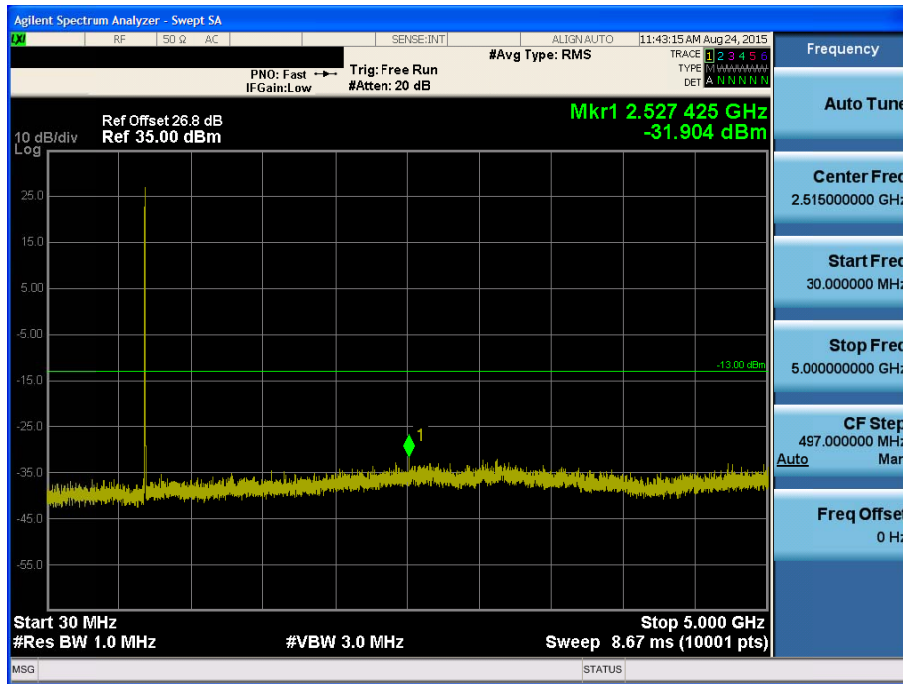

BAND 12. Conducted Spurious Plot _2 (23095ch_5MHz_QPSK_RB 1_0)

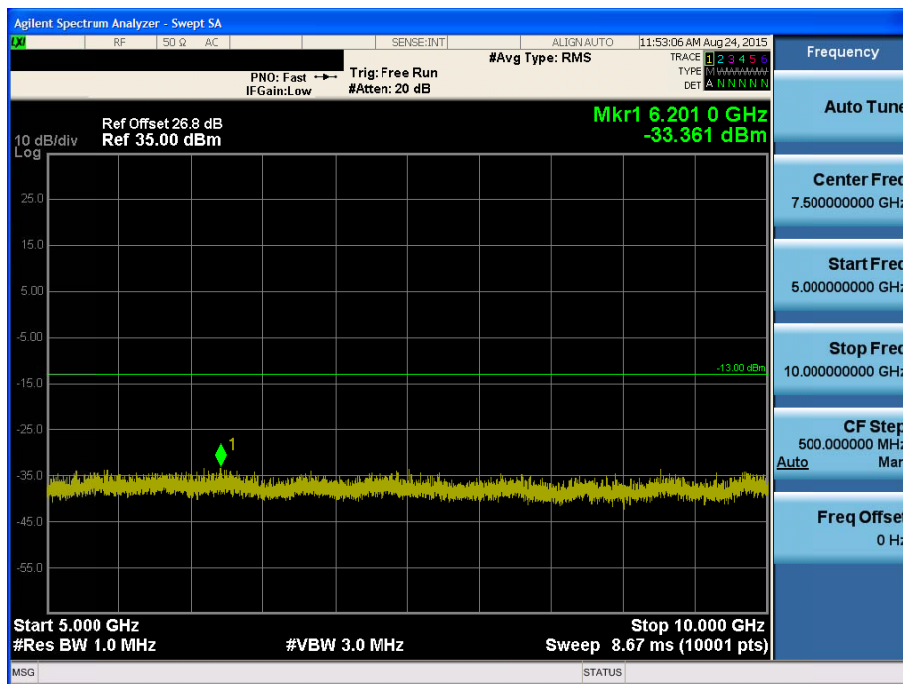

BAND 12. Conducted Spurious Plot _1 (23155ch_5MHz_QPSK_RB 1_0)

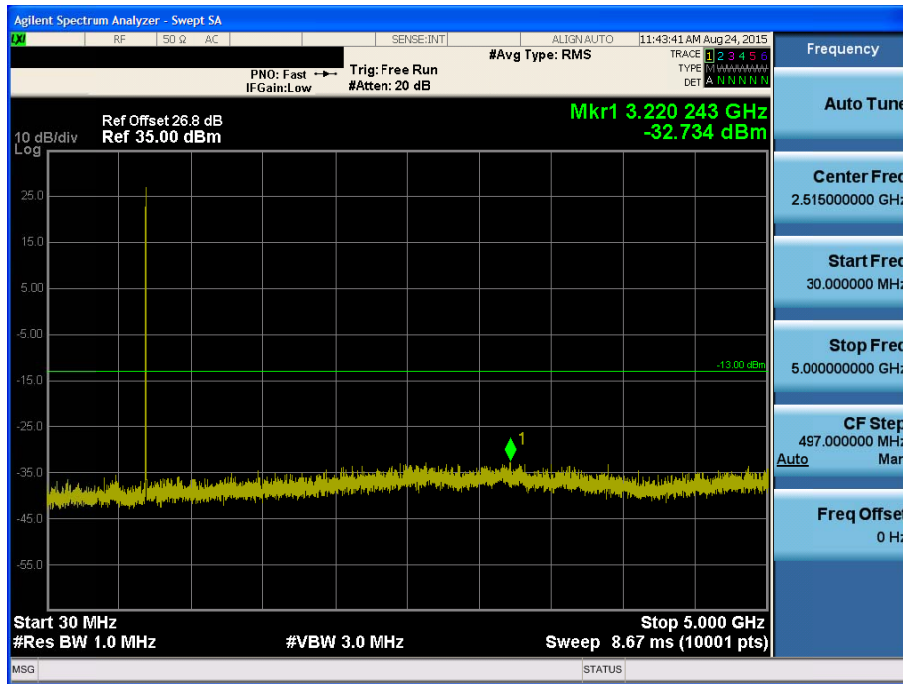

BAND 12. Conducted Spurious Plot _2 (23155ch_5MHz_QPSK_RB 1_0)

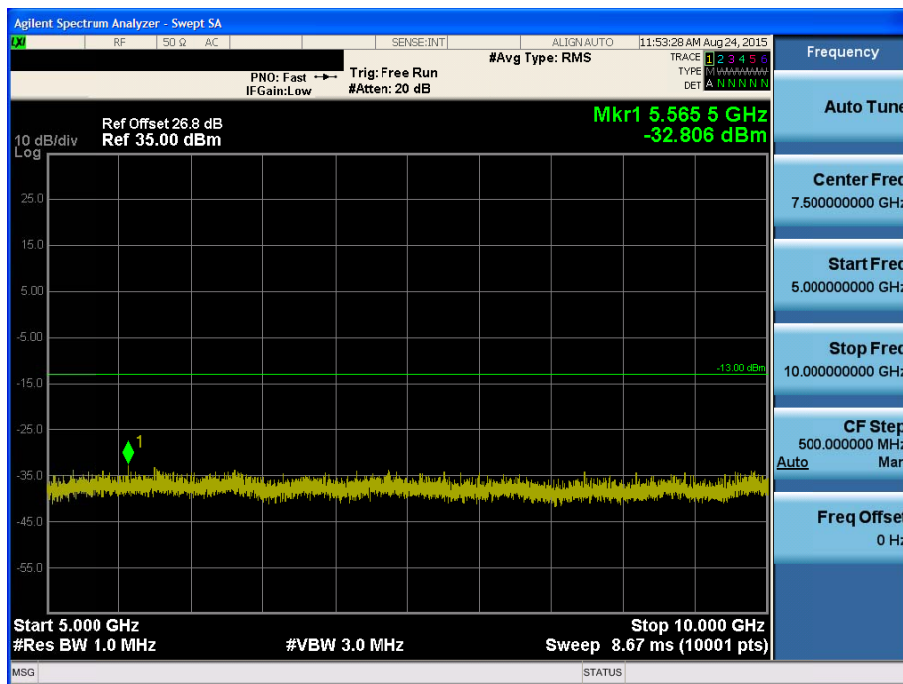

BAND 12. Conducted Spurious Plot _1 (23060ch_10MHz_QPSK_RB 1_0)

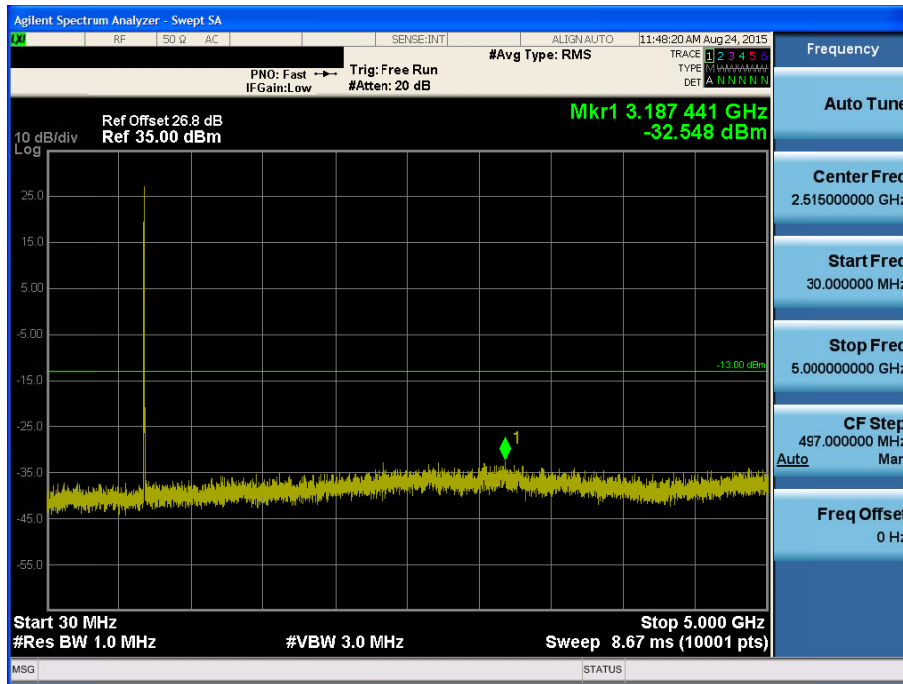

BAND 12. Conducted Spurious Plot _2 (23060ch_10MHz_QPSK_RB 1_0)

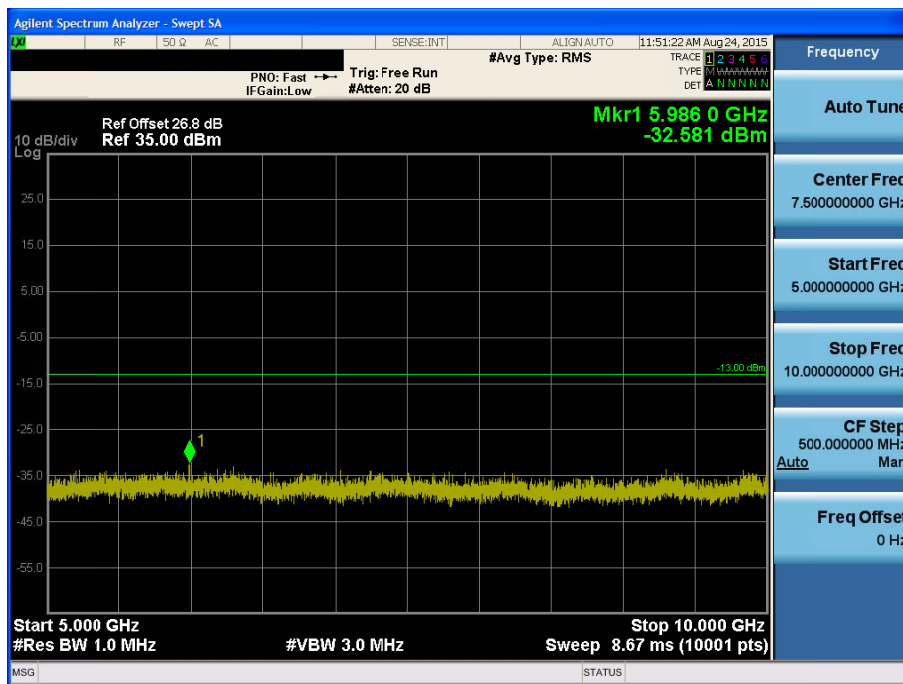

BAND 12. Conducted Spurious Plot _1 (23095ch_10MHz_QPSK_RB 1_0)

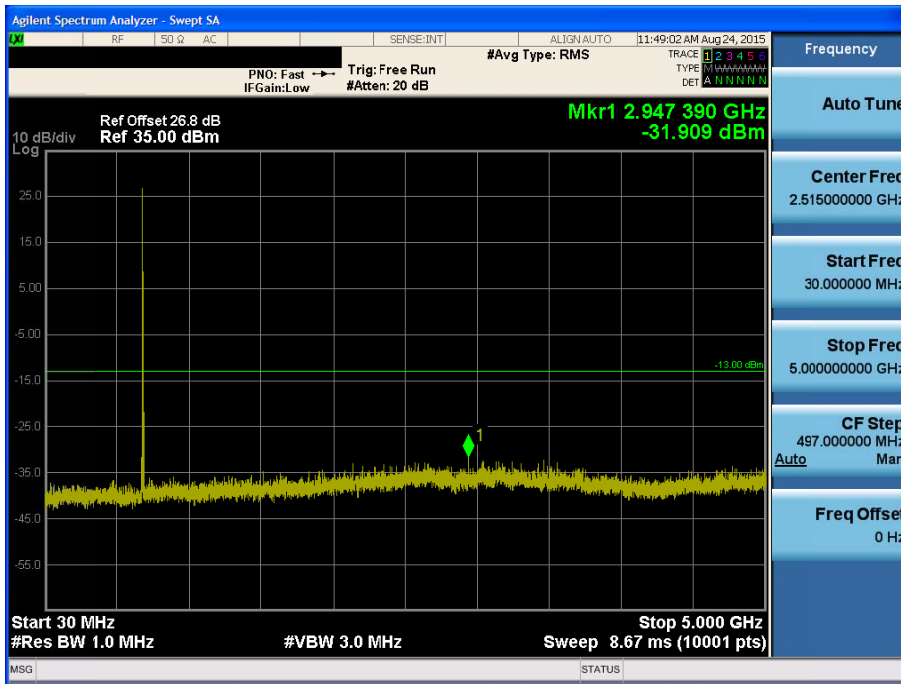

BAND 12. Conducted Spurious Plot _2 (23095ch_10MHz_QPSK_RB 1_0)

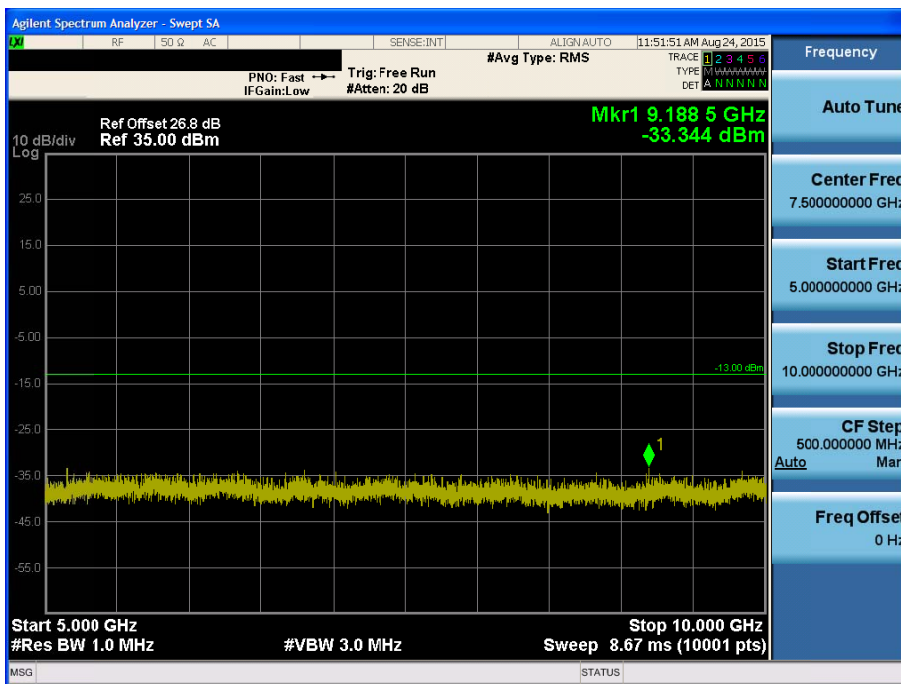

BAND 12. Conducted Spurious Plot _1 (23130ch_10MHz_QPSK_RB 1_0)

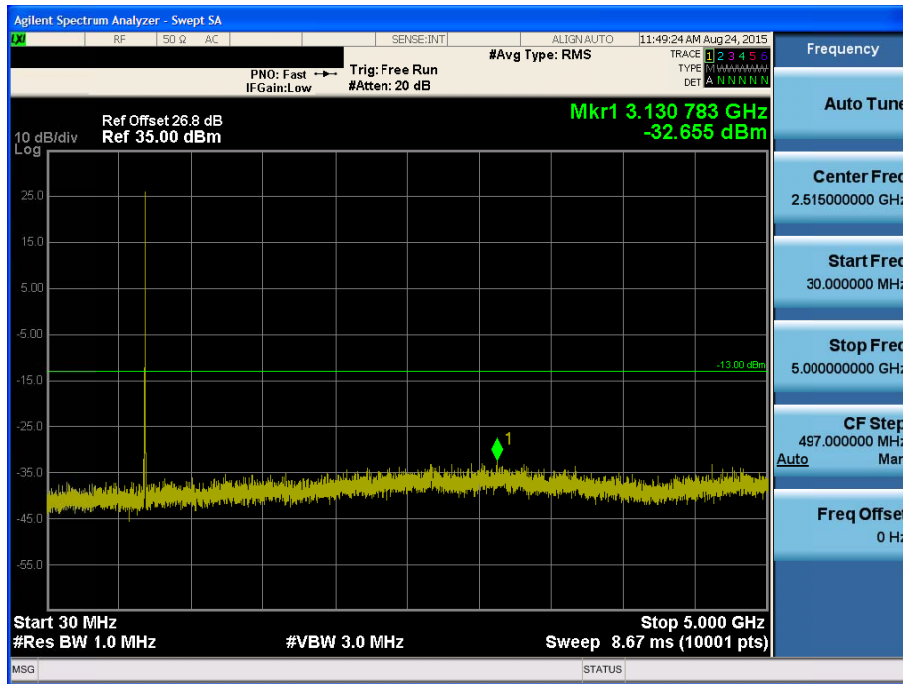

BAND 12. Conducted Spurious Plot _2 (23130ch_10MHz_QPSK_RB 1_0)

