

## APPENDIX B: SYSTEM VERIFICATION

# PCTEST ENGINEERING LABORATORY, INC.

**DUT: Dipole 750 MHz; Type: D750V3; Serial: 1054**

Communication System: UID 0, CW; Frequency: 750 MHz; Duty Cycle: 1:1

Medium: 750 Head Medium parameters used (interpolated):

$f = 750 \text{ MHz}$ ;  $\sigma = 0.893 \text{ S/m}$ ;  $\epsilon_r = 41.11$ ;  $\rho = 1000 \text{ kg/m}^3$

Phantom section: Flat Section; Space: 1.5 cm

Test Date: 07-17-2017; Ambient Temp: 21.9°C; Tissue Temp: 23.8°C

Probe: ES3DV3 - SN3209; ConvF(6.76, 6.76, 6.76); Calibrated: 3/14/2017;

Sensor-Surface: 3mm (Mechanical Surface Detection)

Electronics: DAE4 Sn1415; Calibrated: 3/13/2017

Phantom: SAM with CRP v4.0; Type: QD000P40CD; Serial: TP:1800

Measurement SW: DASY52, Version 52.10; SEMCAD X Version 14.6.10 (7417)

## 750 MHz System Verification at 23.0 dBm (200 mW)

**Area Scan (7x15x1):** Measurement grid: dx=15mm, dy=15mm

**Zoom Scan (5x5x7)/Cube 0:** Measurement grid: dx=8mm, dy=8mm, dz=5mm

Peak SAR (extrapolated) = 2.37 W/kg

**SAR(1 g) = 1.60 W/kg**

Deviation(1 g) = -4.42%

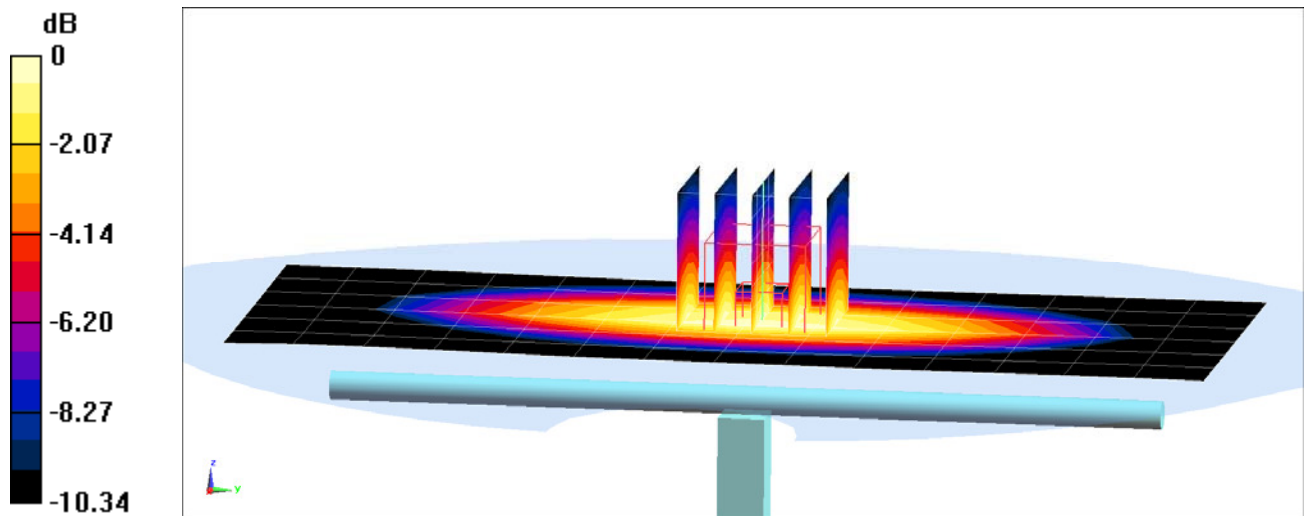

0 dB = 1.86 W/kg = 2.70 dBW/kg

# PCTEST ENGINEERING LABORATORY, INC.

**DUT: Dipole 835 MHz; Type: D835V2; Serial: 4d180**

Communication System: UID 0, CW; Frequency: 835 MHz; Duty Cycle: 1:1

Medium: 835 Head Medium parameters used:

$f = 835 \text{ MHz}$ ;  $\sigma = 0.901 \text{ S/m}$ ;  $\epsilon_r = 41.444$ ;  $\rho = 1000 \text{ kg/m}^3$

Phantom section: Flat Section; Space: 1.5 cm

Test Date: 07-13-2017; Ambient Temp: 21.1°C; Tissue Temp: 21.5°C

Probe: ES3DV3 - SN3209; ConvF(6.36, 6.36, 6.36); Calibrated: 3/14/2017;

Sensor-Surface: 3mm (Mechanical Surface Detection)

Electronics: DAE4 Sn1415; Calibrated: 3/13/2017

Phantom: SAM with CRP v4.0; Type: QD000P40CD; Serial: TP:1800

Measurement SW: DASY52, Version 52.10; SEMCAD X Version 14.6.10 (7417)

## 835 MHz System Verification at 23.0 dBm (200 mW)

**Area Scan (7x14x1):** Measurement grid: dx=15mm, dy=15mm

**Zoom Scan (5x5x7)/Cube 0:** Measurement grid: dx=8mm, dy=8mm, dz=5mm

Peak SAR (extrapolated) = 2.93 W/kg

**SAR(1 g) = 1.99 W/kg**

Deviation(1 g) = 7.45%

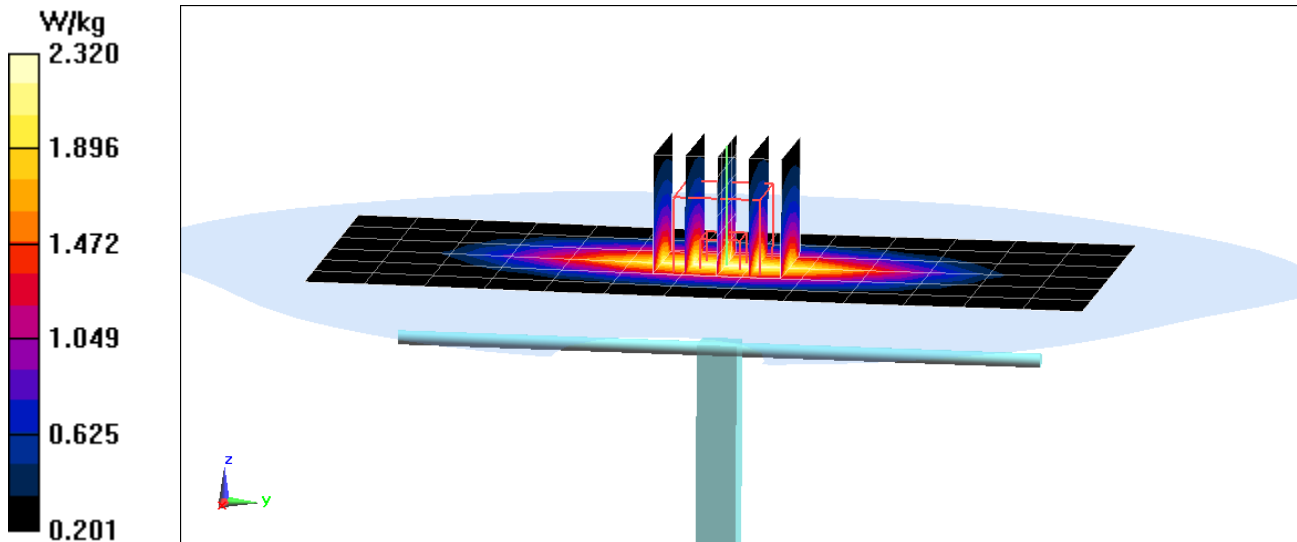

# PCTEST ENGINEERING LABORATORY, INC.

**DUT: Dipole 1750 MHz; Type: D1750V2; Serial: 1092**

Communication System: UID 0, CW; Frequency: 1750 MHz; Duty Cycle: 1:1

Medium: 1750 Head Medium parameters used:

$f = 1750 \text{ MHz}$ ;  $\sigma = 1.412 \text{ S/m}$ ;  $\epsilon_r = 38.858$ ;  $\rho = 1000 \text{ kg/m}^3$

Phantom section: Flat Section; Space: 1.0 cm

Test Date: 07-18-2017; Ambient Temp: 24.2°C; Tissue Temp: 22.0°C

Probe: ES3DV3 - SN3318; ConvF(5.49, 5.49, 5.49); Calibrated: 2/10/2017;

Sensor-Surface: 3mm (Mechanical Surface Detection)

Electronics: DAE4 Sn665; Calibrated: 2/9/2017

Phantom: SAM with CRP (Left); Type: SAM; Serial: 1715

Measurement SW: DASY52, Version 52.10; SEMCAD X Version 14.6.10 (7417)

## 1750 MHz System Verification at 20.0 dBm (100 mW)

**Area Scan (7x9x1):** Measurement grid: dx=15mm, dy=15mm

**Zoom Scan (5x5x7)/Cube 0:** Measurement grid: dx=8mm, dy=8mm, dz=5mm

Peak SAR (extrapolated) = 6.98 W/kg

**SAR(1 g) = 3.82 W/kg**

Deviation(1 g) = 4.95%

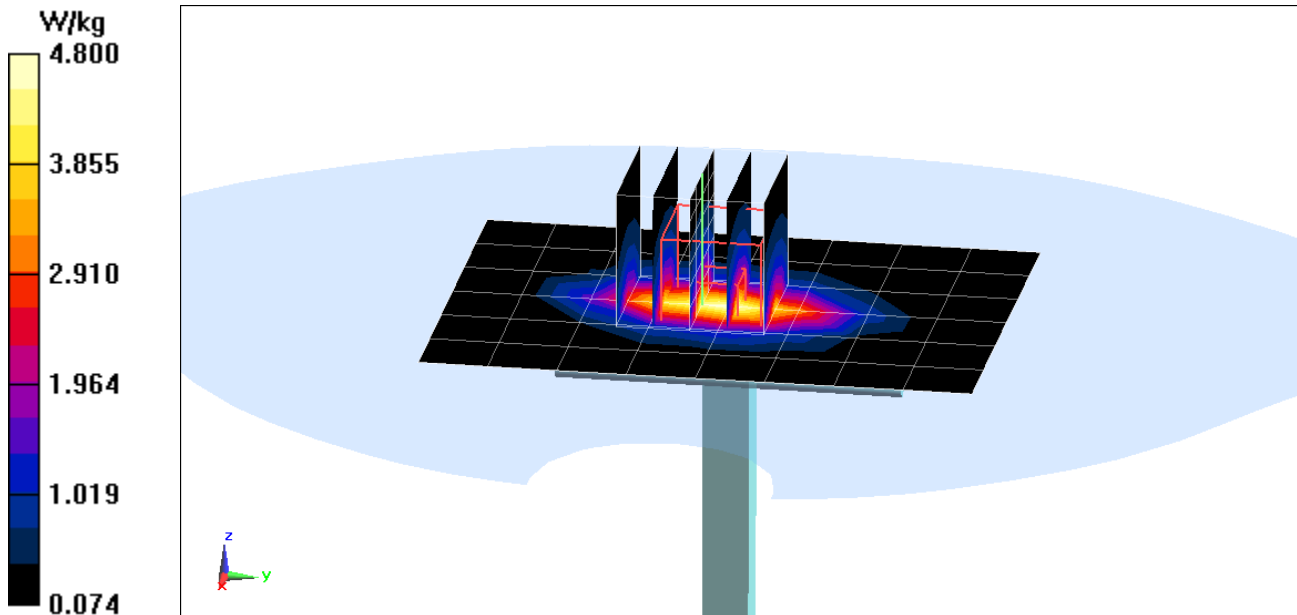

# PCTEST ENGINEERING LABORATORY, INC.

**DUT: Dipole 1900 MHz; Type: D1900V2; Serial: 5d080**

Communication System: UID 0, CW; Frequency: 1900 MHz; Duty Cycle: 1:1  
Medium: 1900 Head Medium parameters used (interpolated):  
 $f = 1900 \text{ MHz}$ ;  $\sigma = 1.422 \text{ S/m}$ ;  $\epsilon_r = 39.569$ ;  $\rho = 1000 \text{ kg/m}^3$   
Phantom section: Flat Section; Space: 1.0 cm

Test Date: 07-17-2017; Ambient Temp: 20.3°C; Tissue Temp: 22.1°C

Probe: ES3DV3 - SN3287; ConvF(5.27, 5.27, 5.27); Calibrated: 9/19/2016;  
Sensor-Surface: 3mm (Mechanical Surface Detection)  
Electronics: DAE4 Sn1408; Calibrated: 9/14/2016  
Phantom: SAM Front; Type: SAM; Serial: 1686  
Measurement SW: DASY52, Version 52.10; SEMCAD X Version 14.6.10 (7417)

## 1900 MHz System Verification at 20.0 dBm (100 mW)

**Area Scan (7x10x1):** Measurement grid: dx=15mm, dy=15mm  
**Zoom Scan (5x5x7)/Cube 0:** Measurement grid: dx=8mm, dy=8mm, dz=5mm  
Peak SAR (extrapolated) = 7.64 W/kg  
**SAR(1 g) = 4.15 W/kg**  
Deviation(1 g) = 5.60%

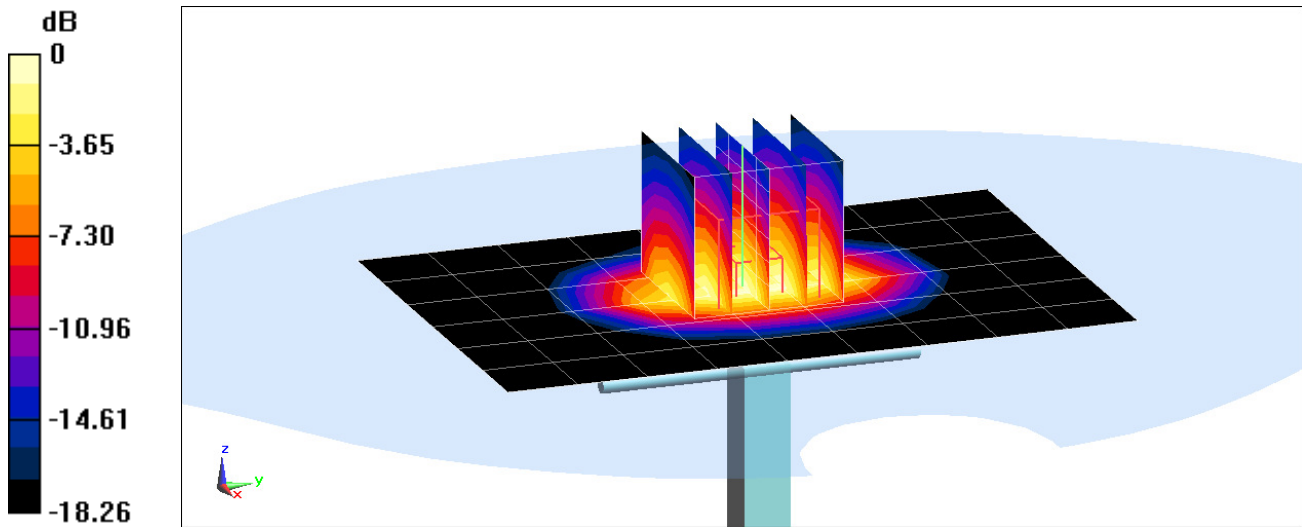

0 dB = 5.27 W/kg = 7.22 dBW/kg

# PCTEST ENGINEERING LABORATORY, INC.

**DUT: Dipole 1900 MHz; Type: D1900V2; Serial: 5d026**

Communication System: UID 0, CW; Frequency: 1900 MHz; Duty Cycle: 1:1  
Medium: 1900 Head Medium parameters used (interpolated):  
 $f = 1900 \text{ MHz}$ ;  $\sigma = 1.424 \text{ S/m}$ ;  $\epsilon_r = 38.739$ ;  $\rho = 1000 \text{ kg/m}^3$   
Phantom section: Flat Section; Space: 1.0 cm

Test Date: 07-19-2017; Ambient Temp: 22.3°C; Tissue Temp: 22.8°C

Probe: ES3DV3 - SN3287; ConvF(5.27, 5.27, 5.27); Calibrated: 9/19/2016;  
Sensor-Surface: 3mm (Mechanical Surface Detection)  
Electronics: DAE4 Sn1408; Calibrated: 9/14/2016  
Phantom: SAM Front; Type: SAM; Serial: 1686  
Measurement SW: DASY52, Version 52.10; SEMCAD X Version 14.6.10 (7417)

## 1900 MHz System Verification at 20.0 dBm (100 mW)

**Area Scan (7x10x1):** Measurement grid: dx=15mm, dy=15mm  
**Zoom Scan (5x5x7)/Cube 0:** Measurement grid: dx=8mm, dy=8mm, dz=5mm  
Peak SAR (extrapolated) = 7.17 W/kg  
**SAR(1 g) = 3.93 W/kg**  
Deviation(1 g) = 0.00%

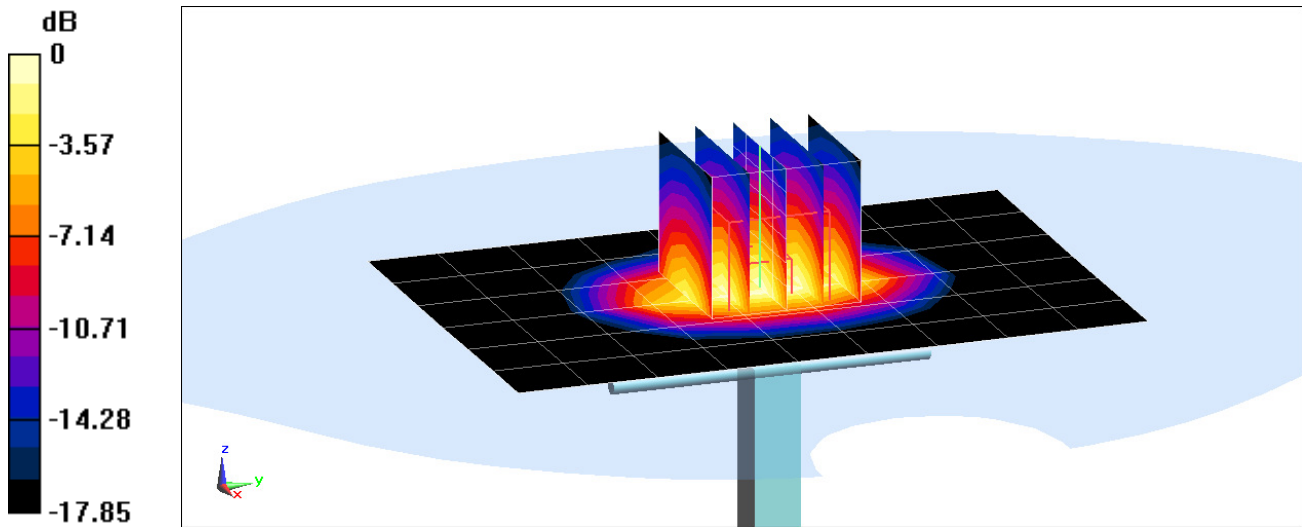

0 dB = 5.00 W/kg = 6.99 dBW/kg

# PCTEST ENGINEERING LABORATORY, INC.

**DUT: Dipole 2450 MHz; Type: D2450V2; Serial: 797**

Communication System: UID 0, CW; Frequency: 2450 MHz; Duty Cycle: 1:1

Medium: 2450 Head Medium parameters used:

$f = 2450 \text{ MHz}$ ;  $\sigma = 1.869 \text{ S/m}$ ;  $\epsilon_r = 38.637$ ;  $\rho = 1000 \text{ kg/m}^3$

Phantom section: Flat Section; Space: 1.0 cm

Test Date: 07-17-2017; Ambient Temp: 22.3°C; Tissue Temp: 22.0°C

Probe: ES3DV3 - SN3213; ConvF(4.7, 4.7, 4.7); Calibrated: 2/10/2017;

Sensor-Surface: 3mm (Mechanical Surface Detection)

Electronics: DAE4 Sn1272; Calibrated: 2/9/2017

Phantom: SAM Right; Type: SAM; Serial: 1757

Measurement SW: DASY52, Version 52.10; SEMCAD X Version 14.6.10 (7417)

## 2450 MHz System Verification at 20.0 dBm (100 mW)

**Area Scan (8x9x1):** Measurement grid: dx=12mm, dy=12mm

**Zoom Scan (7x7x7)/Cube 0:** Measurement grid: dx=5mm, dy=5mm, dz=5mm

Peak SAR (extrapolated) = 11.6 W/kg

**SAR(1 g) = 5.52 W/kg**

Deviation(1 g) = 5.95%

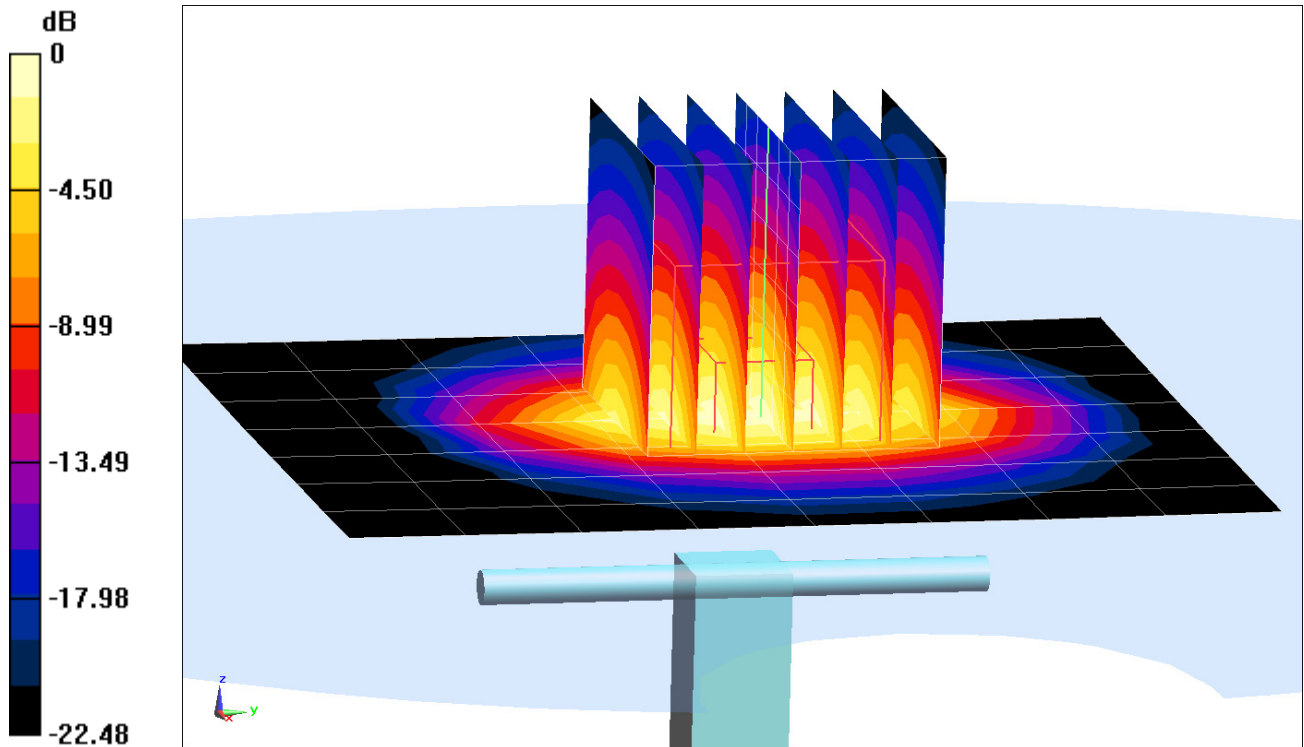

0 dB = 7.33 W/kg = 8.65 dBW/kg

# PCTEST ENGINEERING LABORATORY, INC.

**DUT: Dipole 2450 MHz; Type: D2450V2; Serial: 945**

Communication System: UID 0, CW; Frequency: 2450 MHz; Duty Cycle: 1:1

Medium: 2450 Head Medium parameters used:

$f = 2450 \text{ MHz}$ ;  $\sigma = 1.877 \text{ S/m}$ ;  $\epsilon_r = 38.446$ ;  $\rho = 1000 \text{ kg/m}^3$

Phantom section: Flat Section; Space: 1.0 cm

Test Date: 07-26-2017; Ambient Temp: 21.7°C; Tissue Temp: 21.7°C

Probe: ES3DV3 - SN3213; ConvF(4.7, 4.7, 4.7); Calibrated: 2/10/2017;

Sensor-Surface: 3mm (Mechanical Surface Detection)

Electronics: DAE4 Sn1272; Calibrated: 2/9/2017

Phantom: SAM Right; Type: SAM; Serial: 1757

Measurement SW: DASY52, Version 52.10; SEMCAD X Version 14.6.10 (7417)

## 2450 MHz System Verification at 20.0 dBm (100 mW)

**Area Scan (8x9x1):** Measurement grid: dx=12mm, dy=12mm

**Zoom Scan (7x7x7)/Cube 0:** Measurement grid: dx=5mm, dy=5mm, dz=5mm

Peak SAR (extrapolated) = 11.4 W/kg

**SAR(1 g) = 5.46 W/kg**

Deviation(1 g) = 6.43%

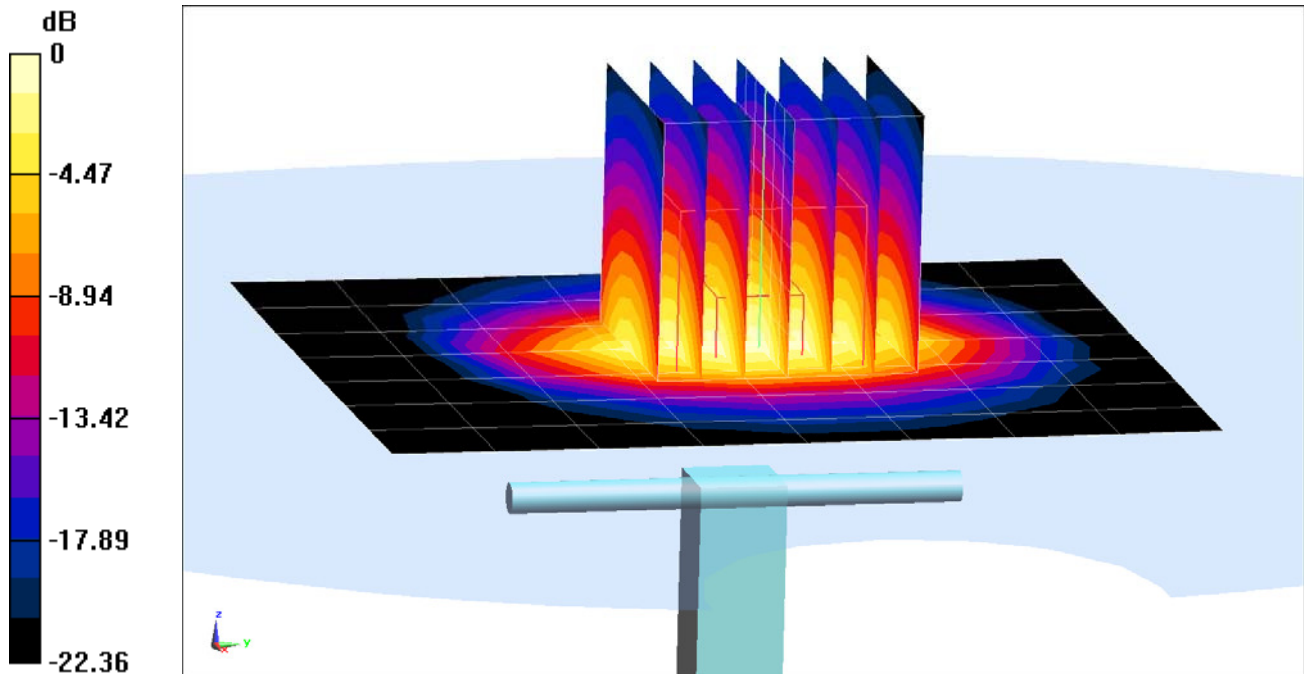

0 dB = 7.22 W/kg = 8.59 dBW/kg



# PCTEST ENGINEERING LABORATORY, INC.

**DUT: Dipole 2600 MHz; Type: D2600V2; Serial: 1004**

Communication System: UID 0, CW; Frequency: 2600 MHz; Duty Cycle: 1:1  
Medium: 2450 Head Medium parameters used:  
 $f = 2600 \text{ MHz}$ ;  $\sigma = 2.013 \text{ S/m}$ ;  $\epsilon_r = 37.472$ ;  $\rho = 1000 \text{ kg/m}^3$   
Phantom section: Flat Section; Space: 1.0 cm

Test Date: 07-13-2017; Ambient Temp: 23.0°C; Tissue Temp: 21.7°C

Probe: ES3DV3 - SN3213; ConvF(4.52, 4.52, 4.52); Calibrated: 2/10/2017;  
Sensor-Surface: 3mm (Mechanical Surface Detection)  
Electronics: DAE4 Sn1272; Calibrated: 2/9/2017  
Phantom: SAM Right; Type: SAM; Serial: 1757  
Measurement SW: DASY52, Version 52.10; SEMCAD X Version 14.6.10 (7417)

## 2600 MHz System Verification at 20.0 dBm (100 mW)

**Area Scan (8x9x1):** Measurement grid: dx=12mm, dy=12mm  
**Zoom Scan (7x7x7)/Cube 0:** Measurement grid: dx=5mm, dy=5mm, dz=5mm  
Peak SAR (extrapolated) = 13.0 W/kg  
**SAR(1 g) = 5.93 W/kg**  
Deviation(1 g) = 2.95%

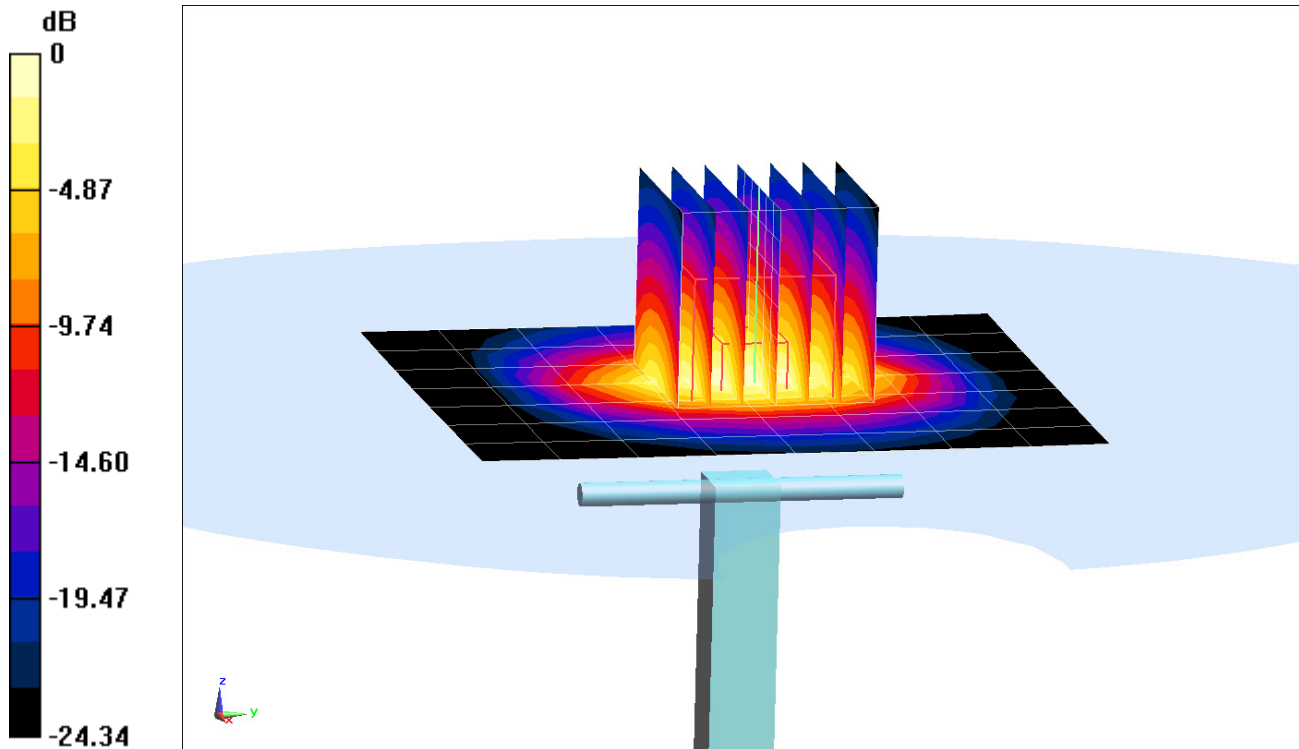

# PCTEST ENGINEERING LABORATORY, INC.

**DUT: Dipole 5 GHz; Type: D5GHzV2; Serial: 1123**

Communication System: UID 0, CW; Frequency: 5250 MHz; Duty Cycle: 1:1  
Medium: 5GHz Head Medium parameters used (interpolated):  
 $f = 5250 \text{ MHz}$ ;  $\sigma = 4.539 \text{ S/m}$ ;  $\epsilon_r = 35.748$ ;  $\rho = 1000 \text{ kg/m}^3$   
Phantom section: Flat Section; Space: 1.0 cm

Test Date: 07-19-2017; Ambient Temp: 22.7°C; Tissue Temp: 21.3°C

Probe: EX3DV4 - SN3914; ConvF(5.49, 5.49, 5.49); Calibrated: 2/13/2017;  
Sensor-Surface: 1.4mm (Mechanical Surface Detection)

Electronics: DAE4 Sn665; Calibrated: 2/9/2017

Phantom: SAM with CRP v5.0 (Right); Type: QD000P40CD; Serial: TP:1759  
Measurement SW: DASY52, Version 52.10; SEMCAD X Version 14.6.10 (7417)

## 5250 MHz System Verification at 17.0 dBm (50 mW)

**Area Scan (7x7x1):** Measurement grid: dx=10mm, dy=10mm

**Zoom Scan (9x9x7)/Cube 0:** Measurement grid: dx=4mm, dy=4mm, dz=1.4mm; Graded Ratio: 1.4

Peak SAR (extrapolated) = 16.5 W/kg

**SAR(1 g) = 3.73 W/kg**

Deviation(1 g) = -5.93%

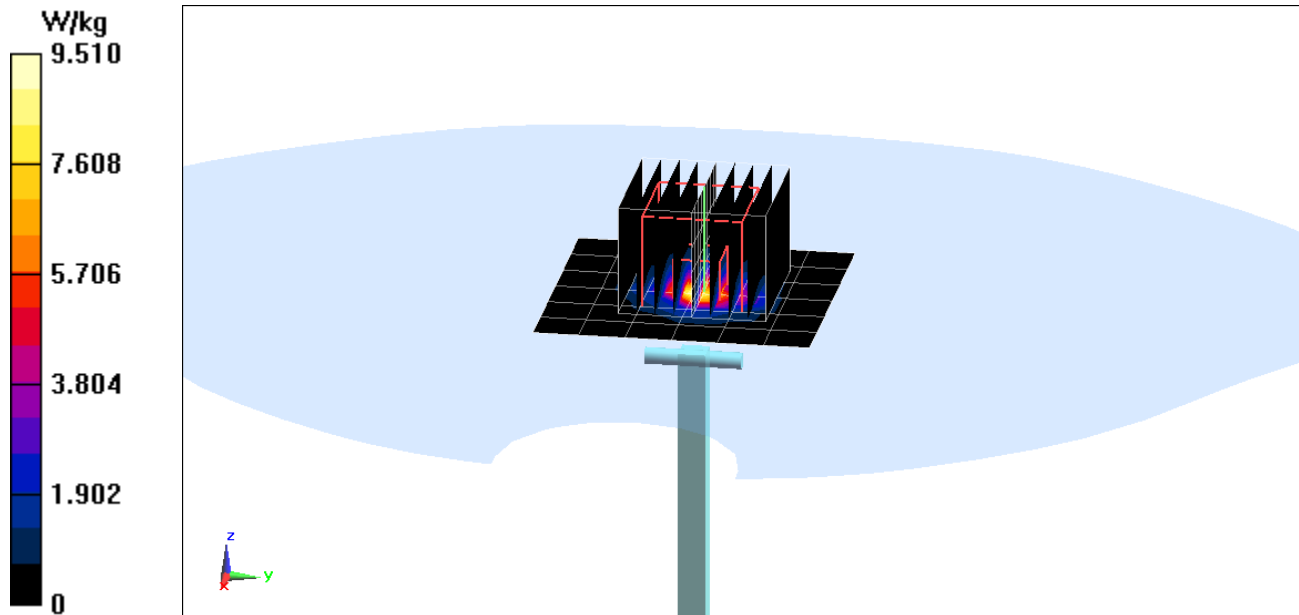

# PCTEST ENGINEERING LABORATORY, INC.

**DUT: Dipole 5 GHz; Type: D5GHzV2; Serial: 1123**

Communication System: UID 0, CW; Frequency: 5600 MHz; Duty Cycle: 1:1

Medium: 5GHz Head Medium parameters used:

$f = 5600 \text{ MHz}$ ;  $\sigma = 4.882 \text{ S/m}$ ;  $\epsilon_r = 35.263$ ;  $\rho = 1000 \text{ kg/m}^3$

Phantom section: Flat Section; Space: 1.0 cm

Test Date: 07-19-2017; Ambient Temp: 22.7°C; Tissue Temp: 21.3°C

Probe: EX3DV4 - SN3914; ConvF(4.94, 4.94, 4.94); Calibrated: 2/13/2017;

Sensor-Surface: 1.4mm (Mechanical Surface Detection)

Electronics: DAE4 Sn665; Calibrated: 2/9/2017

Phantom: SAM with CRP v5.0 (Right); Type: QD000P40CD; Serial: TP:1759

Measurement SW: DASY52, Version 52.10;SEMCAD X Version 14.6.10 (7417)

## 5600 MHz System Verification at 17.0 dBm (50 mW)

**Area Scan (7x7x1):** Measurement grid: dx=10mm, dy=10mm

**Zoom Scan (8x8x7)/Cube 0:** Measurement grid: dx=4mm, dy=4mm, dz=1.4mm; Graded Ratio: 1.4

Peak SAR (extrapolated) = 17.1 W/kg

**SAR(1 g) = 3.92 W/kg**

Deviation(1 g) = -6.89%

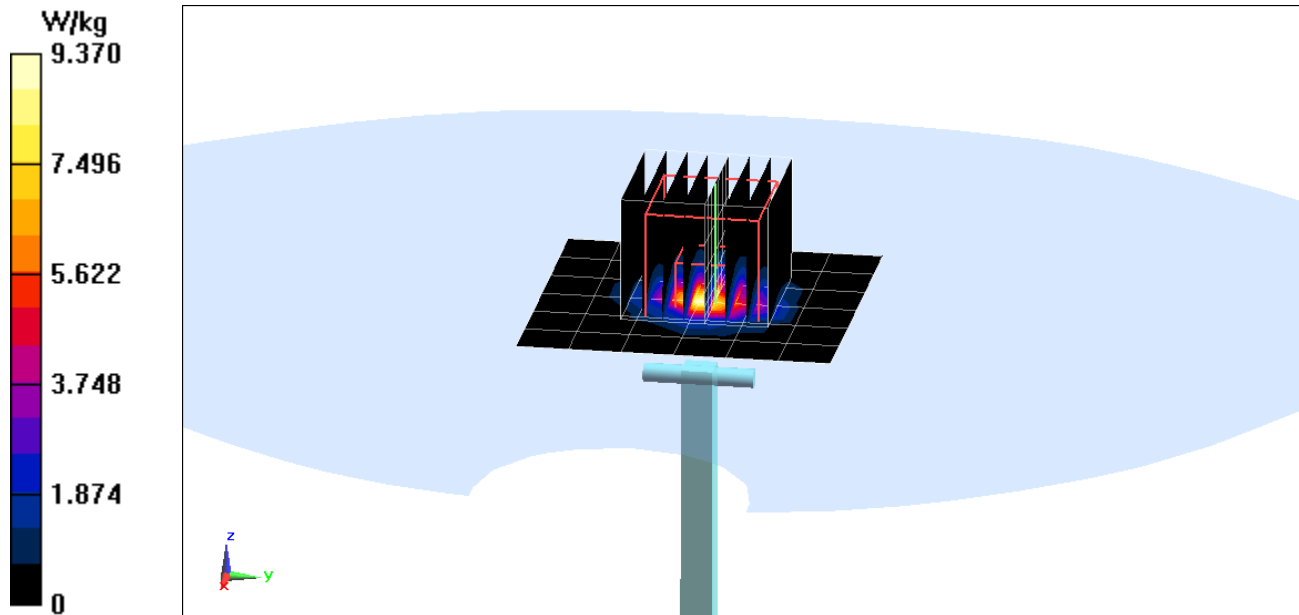

# PCTEST ENGINEERING LABORATORY, INC.

**DUT: Dipole 5 GHz; Type: D5GHzV2; Serial: 1123**

Communication System: UID 0, CW; Frequency: 5750 MHz; Duty Cycle: 1:1  
Medium: 5GHz Head Medium parameters used (interpolated):  
 $f = 5750 \text{ MHz}$ ;  $\sigma = 5.047 \text{ S/m}$ ;  $\epsilon_r = 35.069$ ;  $\rho = 1000 \text{ kg/m}^3$   
Phantom section: Flat Section; Space: 1.0 cm

Test Date: 07-19-2017; Ambient Temp: 22.7°C; Tissue Temp: 21.3°C

Probe: EX3DV4 - SN3914; ConvF(4.91, 4.91, 4.91); Calibrated: 2/13/2017;  
Sensor-Surface: 1.4mm (Mechanical Surface Detection)

Electronics: DAE4 Sn665; Calibrated: 2/9/2017

Phantom: SAM with CRP v5.0 (Right); Type: QD000P40CD; Serial: TP:1759  
Measurement SW: DASY52, Version 52.10; SEMCAD X Version 14.6.10 (7417)

## 5750 MHz System Verification at 17.0 dBm (50 mW)

**Area Scan (7x7x1):** Measurement grid: dx=10mm, dy=10mm

**Zoom Scan (8x8x7)/Cube 0:** Measurement grid: dx=4mm, dy=4mm, dz=1.4mm; Graded Ratio: 1.4

Peak SAR (extrapolated) = 17.9 W/kg

**SAR(1 g) = 3.92 W/kg**

Deviation(1 g) = -4.74%

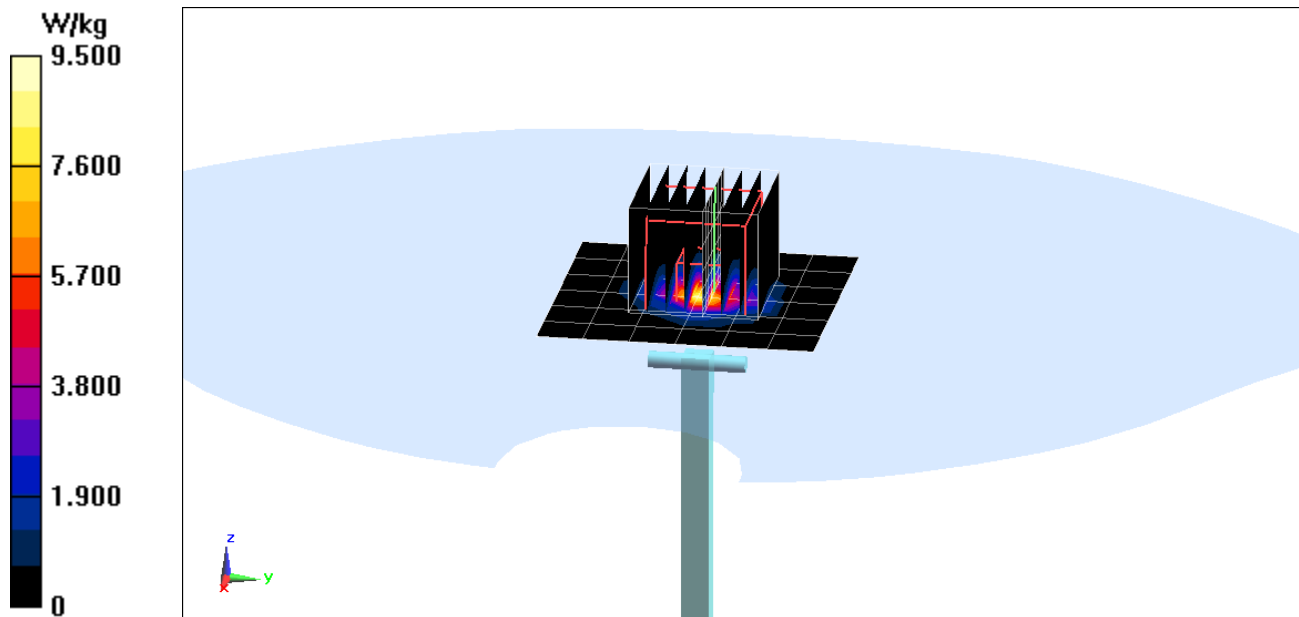

# PCTEST ENGINEERING LABORATORY, INC.

**DUT: Dipole 750 MHz; Type: D750V3; Serial: 1054**

Communication System: UID 0, CW; Frequency: 750 MHz; Duty Cycle: 1:1  
Medium: 750 Body Medium parameters used (interpolated):  
 $f = 750 \text{ MHz}$ ;  $\sigma = 0.971 \text{ S/m}$ ;  $\epsilon_r = 56.166$ ;  $\rho = 1000 \text{ kg/m}^3$   
Phantom section: Flat Section; Space: 1.5 cm

Test Date: 07-11-2017; Ambient Temp: 22.4°C; Tissue Temp: 20.5°C

Probe: ES3DV3 - SN3213; ConvF(6.38, 6.38, 6.38); Calibrated: 2/10/2017;  
Sensor-Surface: 3mm (Mechanical Surface Detection)  
Electronics: DAE4 Sn1272; Calibrated: 2/9/2017  
Phantom: SAM Front; Type: QD000P40CD; Serial: TP:1758  
Measurement SW: DASY52, Version 52.10; SEMCAD X Version 14.6.10 (7417)

## 750 MHz System Verification at 23.0 dBm (200 mW)

**Area Scan (7x15x1):** Measurement grid: dx=15mm, dy=15mm  
**Zoom Scan (5x5x7)/Cube 0:** Measurement grid: dx=8mm, dy=8mm, dz=5mm  
Peak SAR (extrapolated) = 2.56 W/kg  
**SAR(1 g) = 1.71 W/kg**  
Deviation(1 g) = -0.70%

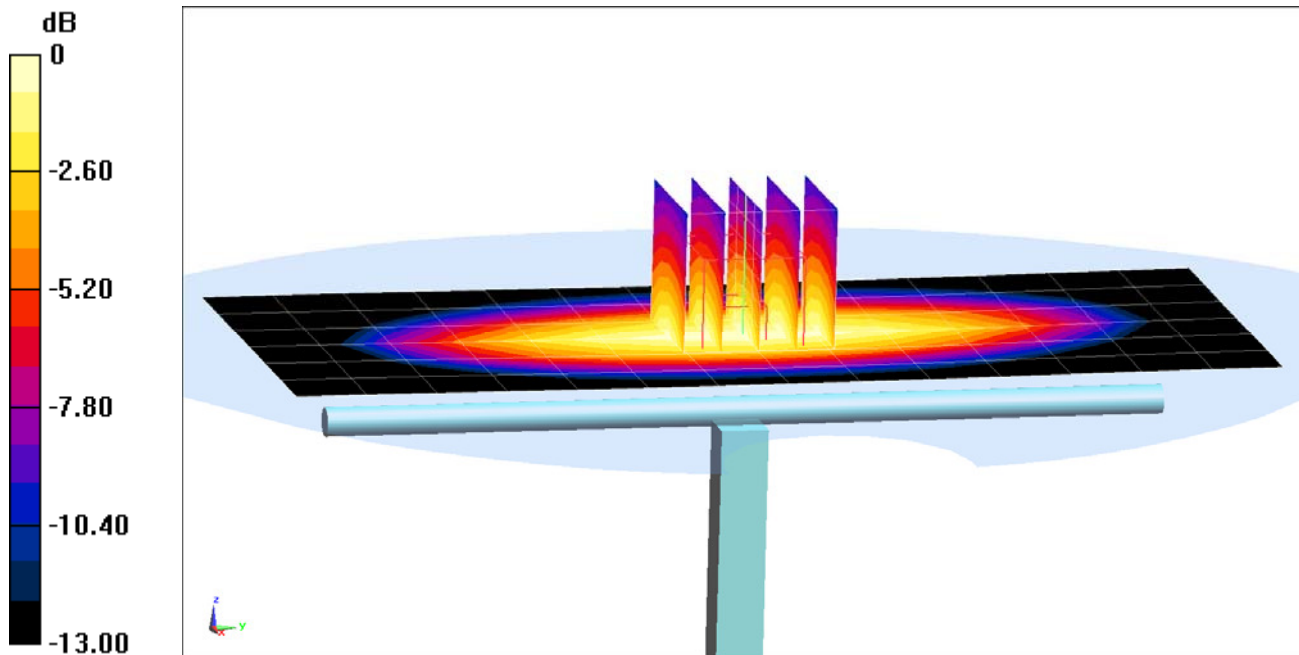

0 dB = 2.01 W/kg = 3.03 dBW/kg

# PCTEST ENGINEERING LABORATORY, INC.

**DUT: Dipole 750 MHz; Type: D750V3; Serial: 1054**

Communication System: UID 0, CW; Frequency: 750 MHz; Duty Cycle: 1:1

Medium: 750 Body Medium parameters used (interpolated):

$f = 750 \text{ MHz}$ ;  $\sigma = 0.958 \text{ S/m}$ ;  $\epsilon_r = 55.007$ ;  $\rho = 1000 \text{ kg/m}^3$

Phantom section: Flat Section; Space: 1.5 cm

Test Date: 07-24-2017; Ambient Temp: 21.7°C; Tissue Temp: 22.0°C

Probe: EX3DV4 - SN7406; ConvF(9.9, 9.9, 9.9); Calibrated: 4/18/2017;

Sensor-Surface: 1.4mm (Mechanical Surface Detection)

Electronics: DAE4 Sn1407; Calibrated: 4/11/2017

Phantom: SAM Right; Type: QD000P40CD; Serial: TP:7535

Measurement SW: DASY52, Version 52.10; SEMCAD X Version 14.6.10 (7417)

## 750 MHz System Verification at 23.0 dBm (200 mW)

**Area Scan (7x15x1):** Measurement grid: dx=15mm, dy=15mm

**Zoom Scan (5x5x7)/Cube 0:** Measurement grid: dx=8mm, dy=8mm, dz=5mm

Peak SAR (extrapolated) = 2.70 W/kg

**SAR(1 g) = 1.75 W/kg**

Deviation(1 g) = 1.63%

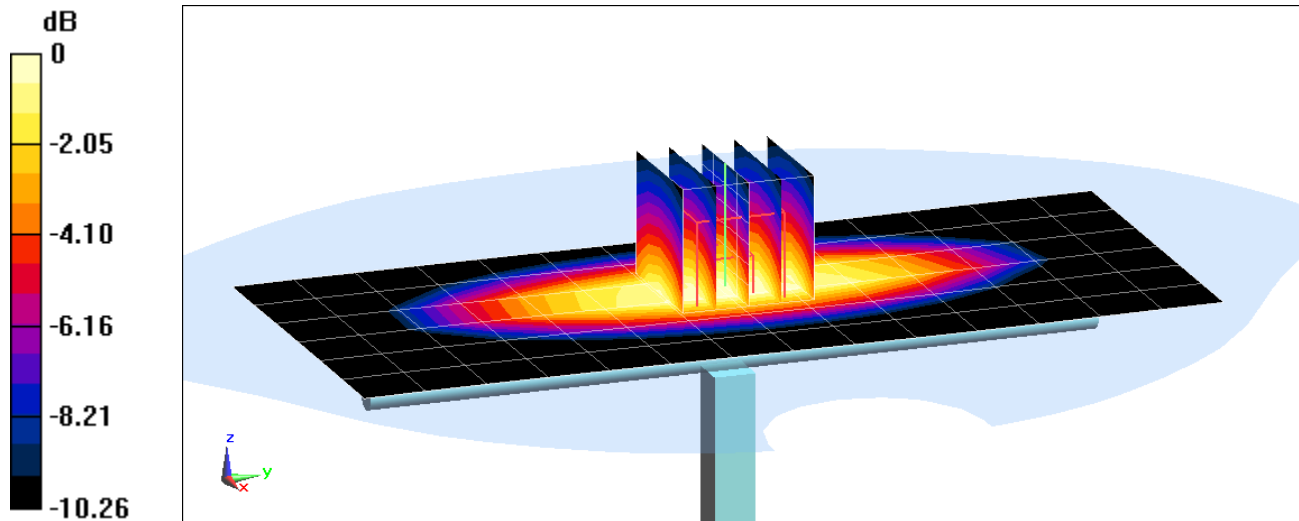

0 dB = 2.36 W/kg = 3.73 dBW/kg

# PCTEST ENGINEERING LABORATORY, INC.

**DUT: Dipole 835 MHz; Type: D835V2; Serial: 4d180**

Communication System: UID 0, CW; Frequency: 835 MHz; Duty Cycle: 1:1

Medium: 835 Body Medium parameters used:

$f = 835 \text{ MHz}$ ;  $\sigma = 1.008 \text{ S/m}$ ;  $\epsilon_r = 54.953$ ;  $\rho = 1000 \text{ kg/m}^3$

Phantom section: Flat Section; Space: 1.5 cm

Test Date: 07-13-2017; Ambient Temp: 21.1°C; Tissue Temp: 20.0°C

Probe: EX3DV4 - SN7406; ConvF(9.77, 9.77, 9.77); Calibrated: 4/18/2017;

Sensor-Surface: 1.4mm (Mechanical Surface Detection)

Electronics: DAE4 Sn1407; Calibrated: 4/11/2017

Phantom: SAM Right; Type: QD000P40CD; Serial: TP:7535

Measurement SW: DASY52, Version 52.10; SEMCAD X Version 14.6.10 (7417)

## 835 MHz System Verification at 23.0 dBm (200 mW)

**Area Scan (7x14x1):** Measurement grid: dx=15mm, dy=15mm

**Zoom Scan (5x5x7)/Cube 0:** Measurement grid: dx=8mm, dy=8mm, dz=5mm

Peak SAR (extrapolated) = 3.16 W/kg

**SAR(1 g) = 2.06 W/kg**

Deviation(1 g) = 7.18%

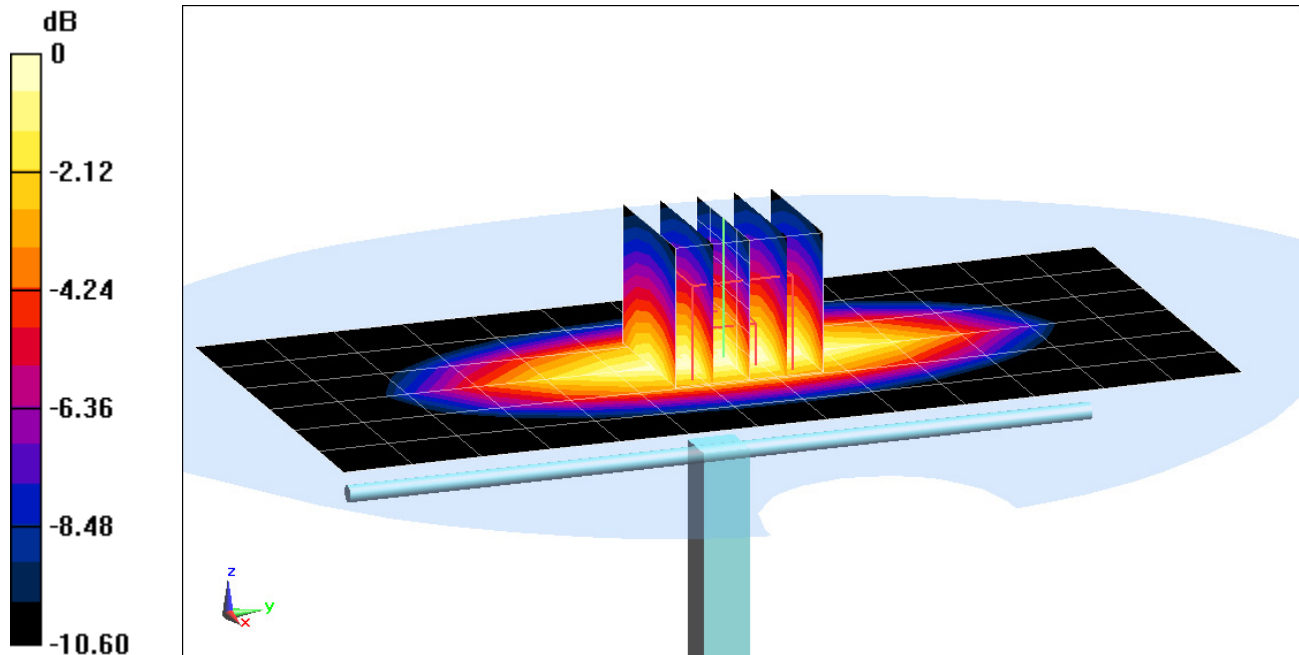

0 dB = 2.78 W/kg = 4.44 dBW/kg

# PCTEST ENGINEERING LABORATORY, INC.

**DUT: Dipole 1750 MHz; Type: D1750V2; Serial: 1092**

Communication System: UID 0, CW; Frequency: 1750 MHz; Duty Cycle: 1:1

Medium: 1750 Body Medium parameters used:

$f = 1750 \text{ MHz}$ ;  $\sigma = 1.52 \text{ S/m}$ ;  $\epsilon_r = 51.488$ ;  $\rho = 1000 \text{ kg/m}^3$

Phantom section: Flat Section; Space: 1.0 cm

Test Date: 07-17-2017; Ambient Temp: 22.4°C; Tissue Temp: 20.3°C

Probe: ES3DV3 - SN3318; ConvF(5.12, 5.12, 5.12); Calibrated: 2/10/2017;

Sensor-Surface: 3mm (Mechanical Surface Detection)

Electronics: DAE4 Sn665; Calibrated: 2/9/2017

Phantom: SAM with CRP v5.0 (Right); Type: QD000P40CD; Serial: TP:1759

Measurement SW: DASY52, Version 52.10; SEMCAD X Version 14.6.10 (7417)

## 1750 MHz System Verification at 20.0 dBm (100 mW)

**Area Scan (7x9x1):** Measurement grid: dx=15mm, dy=15mm

**Zoom Scan (5x5x7)/Cube 0:** Measurement grid: dx=8mm, dy=8mm, dz=5mm

Peak SAR (extrapolated) = 6.89 W/kg

**SAR(1 g) = 3.88 W/kg**

Deviation(1 g) = 4.86%

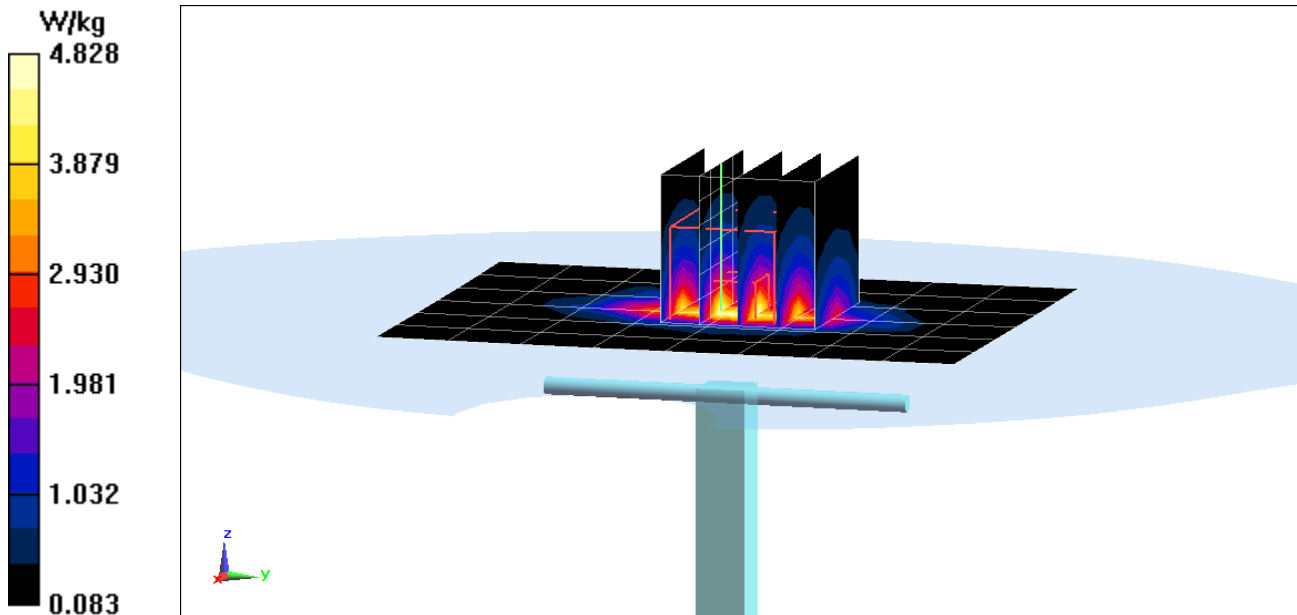



# PCTEST ENGINEERING LABORATORY, INC.

**DUT: Dipole 1750 MHz; Type: D1750V2; Serial: 1092**

Communication System: UID 0, CW; Frequency: 1750 MHz; Duty Cycle: 1:1

Medium: 1750 Body Medium parameters used:

$f = 1750 \text{ MHz}$ ;  $\sigma = 1.525 \text{ S/m}$ ;  $\epsilon_r = 50.852$ ;  $\rho = 1000 \text{ kg/m}^3$

Phantom section: Flat Section; Space: 1.0 cm

Test Date: 07-20-2017; Ambient Temp: 19.9°C; Tissue Temp: 20.0°C

Probe: ES3DV3 - SN3209; ConvF(5.13, 5.13, 5.13); Calibrated: 3/14/2017;

Sensor-Surface: 3mm (Mechanical Surface Detection)

Electronics: DAE4 Sn1415; Calibrated: 3/13/2017

Phantom: SAM with CRP v4.0 Left; Type: QD000P40CD; Serial: TP:1692

Measurement SW: DASY52, Version 52.10; SEMCAD X Version 14.6.10 (7417)

## 1750 MHz System Verification at 20.0 dBm (100 mW)

**Area Scan (7x9x1):** Measurement grid: dx=15mm, dy=15mm

**Zoom Scan (5x5x7)/Cube 0:** Measurement grid: dx=8mm, dy=8mm, dz=5mm

Peak SAR (extrapolated) = 6.98 W/kg

**SAR(1 g) = 3.9 W/kg**

Deviation(1 g) = 5.41%

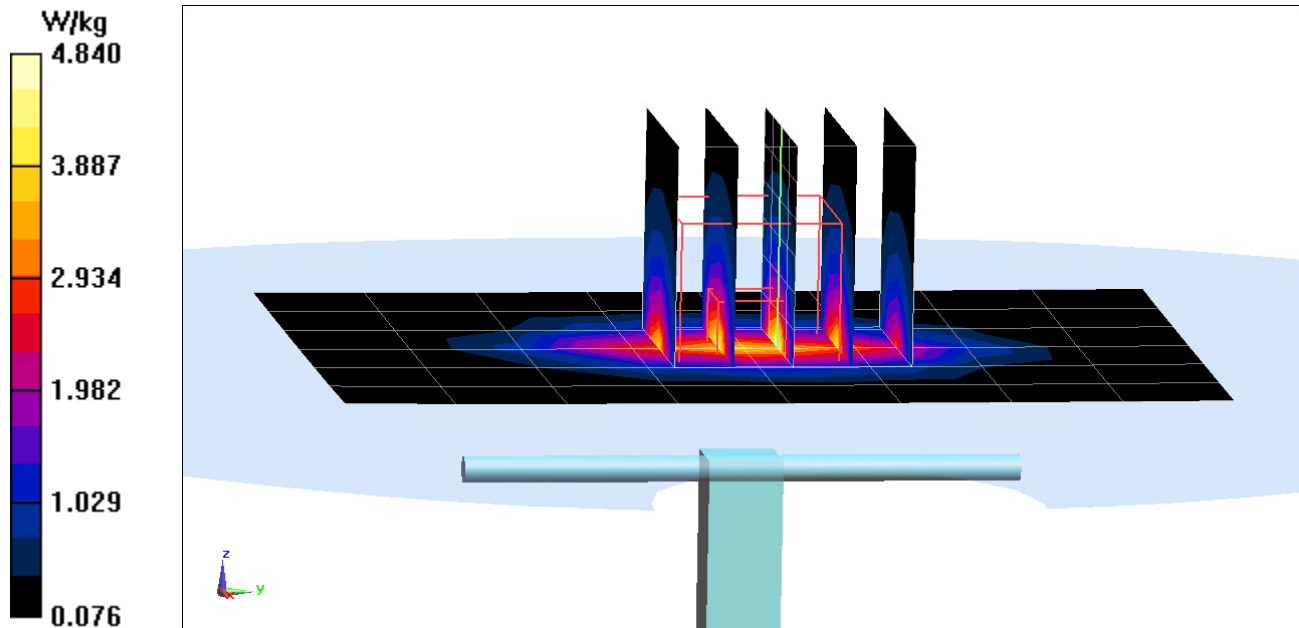

# PCTEST ENGINEERING LABORATORY, INC.

**DUT: Dipole 1900 MHz; Type: D1900V2; Serial: 5d026**

Communication System: UID 0, CW; Frequency: 1900 MHz; Duty Cycle: 1:1  
Medium: 1900 Body Medium parameters used (interpolated):  
 $f = 1900 \text{ MHz}$ ;  $\sigma = 1.557 \text{ S/m}$ ;  $\epsilon_r = 52.541$ ;  $\rho = 1000 \text{ kg/m}^3$   
Phantom section: Flat Section; Space: 1.0 cm

Test Date: 07-12-2017; Ambient Temp: 22.1°C; Tissue Temp: 22.3°C

Probe: ES3DV3 - SN3318; ConvF(4.96, 4.96, 4.96); Calibrated: 2/10/2017;  
Sensor-Surface: 3mm (Mechanical Surface Detection)  
Electronics: DAE4 Sn665; Calibrated: 2/9/2017  
Phantom: SAM with CRP (Left); Type: SAM; Serial: 1715  
Measurement SW: DASY52, Version 52.10; SEMCAD X Version 14.6.10 (7417)

## 1900 MHz System Verification at 20.0 dBm (100 mW)

**Area Scan (7x10x1):** Measurement grid: dx=15mm, dy=15mm  
**Zoom Scan (5x5x7)/Cube 0:** Measurement grid: dx=8mm, dy=8mm, dz=5mm  
Peak SAR (extrapolated) = 7.49 W/kg  
**SAR(1 g) = 4.18 W/kg**  
Deviation(1 g) = 3.72%

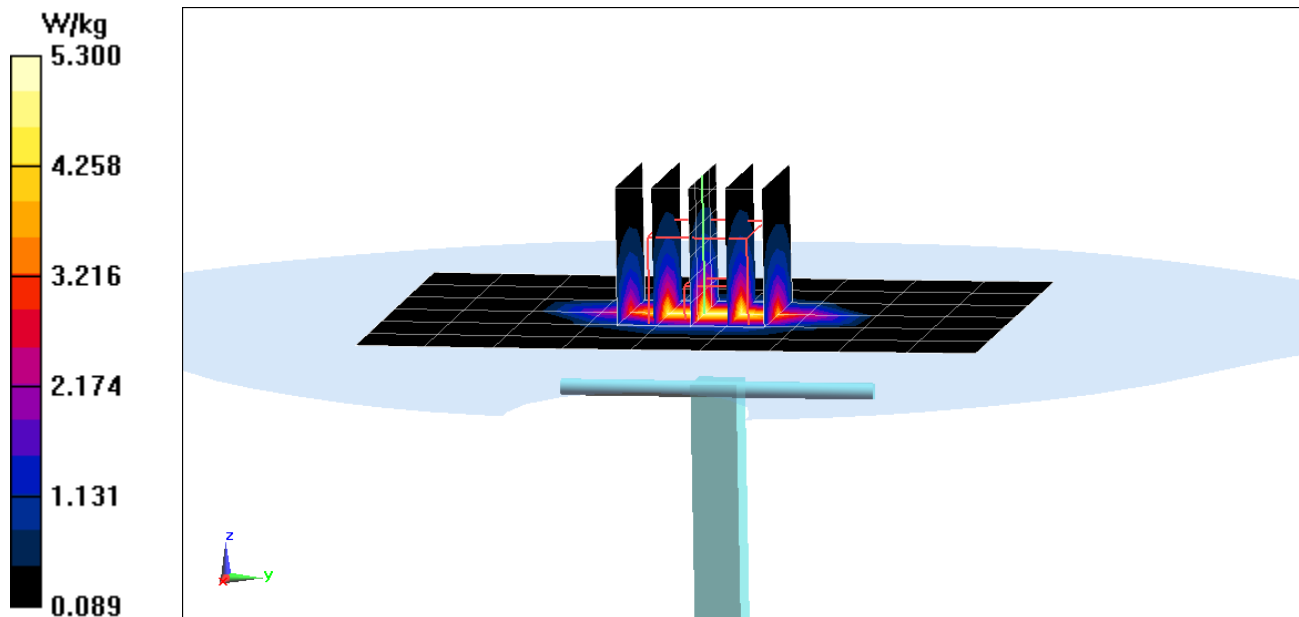

# PCTEST ENGINEERING LABORATORY, INC.

**DUT: Dipole 2450 MHz; Type: D2450V2; Serial: 797**

Communication System: UID 0, CW; Frequency: 2450 MHz; Duty Cycle: 1:1

Medium: 2450 Body Medium parameters used:

$f = 2450$  MHz;  $\sigma = 1.967$  S/m;  $\epsilon_r = 52.615$ ;  $\rho = 1000$  kg/m<sup>3</sup>

Phantom section: Flat Section; Space: 1.0 cm

Test Date: 07-12-2017; Ambient Temp: 21.1°C; Tissue Temp: 23.1°C

Probe: ES3DV3 - SN3287; ConvF(4.35, 4.35, 4.35); Calibrated: 9/19/2016;

Sensor-Surface: 3mm (Mechanical Surface Detection)

Electronics: DAE4 Sn1408; Calibrated: 9/14/2016

Phantom: SAM Front; Type: SAM; Serial: 1686

Measurement SW: DASY52, Version 52.10; SEMCAD X Version 14.6.10 (7417)

## 2450 MHz System Verification at 20.0 dBm (100 mW)

**Area Scan (8x9x1):** Measurement grid: dx=12mm, dy=12mm

**Zoom Scan (7x7x7)/Cube 0:** Measurement grid: dx=5mm, dy=5mm, dz=5mm

Peak SAR (extrapolated) = 11.1 W/kg

**SAR(1 g) = 5.42 W/kg**

Deviation(1 g) = 6.90%

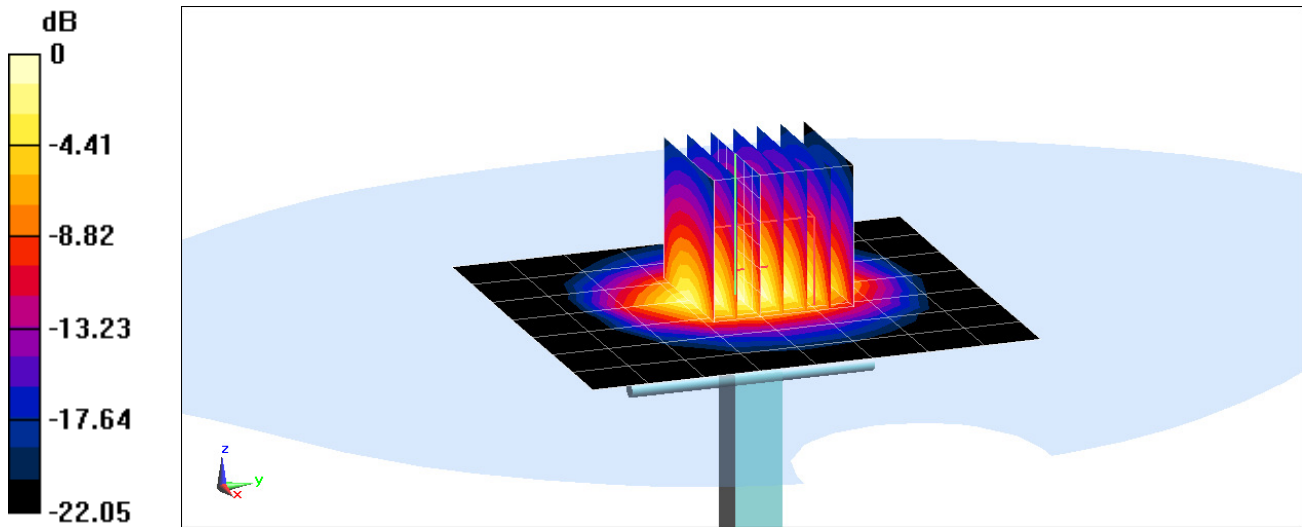

0 dB = 7.11 W/kg = 8.52 dBW/kg

# PCTEST ENGINEERING LABORATORY, INC.

**DUT: Dipole 2600 MHz; Type: D2600V2; Serial: 1071**

Communication System: UID 0, CW; Frequency: 2600 MHz; Duty Cycle: 1:1

Medium: 2450 Body Medium parameters used:

$f = 2600$  MHz;  $\sigma = 2.219$  S/m;  $\epsilon_r = 51.988$ ;  $\rho = 1000$  kg/m<sup>3</sup>

Phantom section: Flat Section; Space: 1.0 cm

Test Date: 07-20-2017; Ambient Temp: 22.5°C; Tissue Temp: 23.9°C

Probe: ES3DV3 - SN3287; ConvF(4.12, 4.12, 4.12); Calibrated: 9/19/2016;

Sensor-Surface: 3mm (Mechanical Surface Detection)

Electronics: DAE4 Sn1408; Calibrated: 9/14/2016

Phantom: SAM Left; Type: QD000P40CA; Serial: TP:82355

Measurement SW: DASY52, Version 52.10; SEMCAD X Version 14.6.10 (7417)

## 2600 MHz System Verification at 20.0 dBm (100 mW)

**Area Scan (8x9x1):** Measurement grid: dx=12mm, dy=12mm

**Zoom Scan (7x7x7)/Cube 0:** Measurement grid: dx=5mm, dy=5mm, dz=5mm

Peak SAR (extrapolated) = 12.7 W/kg

**SAR(1 g) = 5.82 W/kg**

Deviation(1 g) = 7.38%

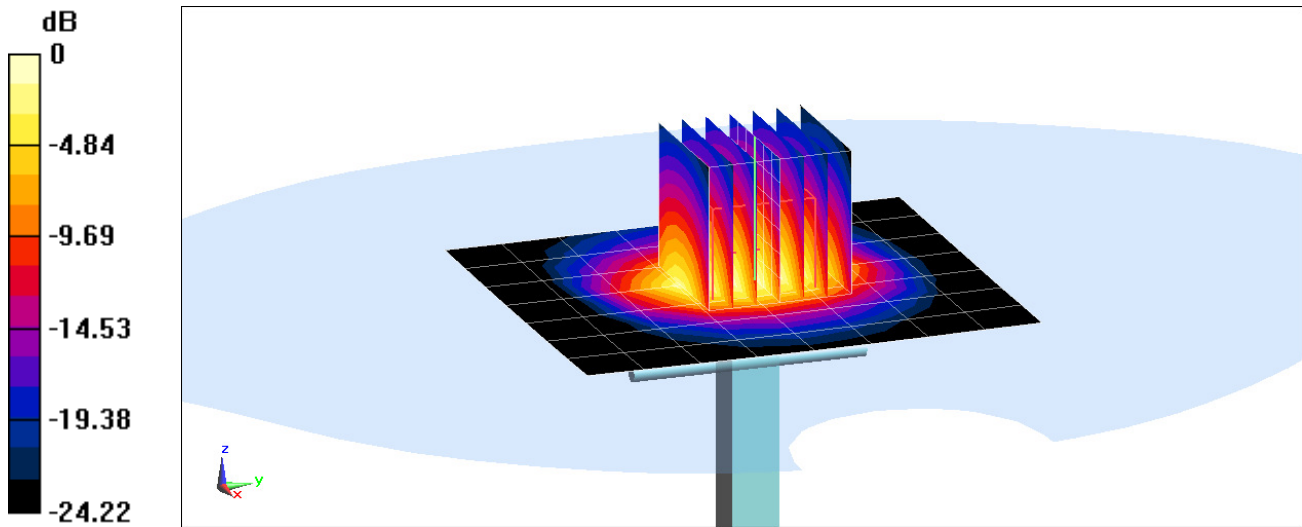

0 dB = 7.35 W/kg = 8.66 dBW/kg

# PCTEST ENGINEERING LABORATORY, INC.

**DUT: Dipole 5 GHz; Type: D5GHzV2; Serial: 1123**

Communication System: UID 0, CW; Frequency: 5250 MHz; Duty Cycle: 1:1  
Medium: 5 GHz Body Medium parameters used (interpolated):  
 $f = 5250 \text{ MHz}$ ;  $\sigma = 5.417 \text{ S/m}$ ;  $\epsilon_r = 47.715$ ;  $\rho = 1000 \text{ kg/m}^3$   
Phantom section: Flat Section; Space: 1.0 cm

Test Date: 07-24-2017; Ambient Temp: 22.1°C; Tissue Temp: 21.3°C

Probe: EX3DV4 - SN3589; ConvF(4.19, 4.19, 4.19); Calibrated: 1/13/2017;  
Sensor-Surface: 1.4mm (Mechanical Surface Detection)

Electronics: DAE4 Sn1466; Calibrated: 1/16/2017

Phantom: SAM with CRP v5.0 Front; Type: QD000P40CD; Serial: 1646

Measurement SW: DASY52, Version 52.10; SEMCAD X Version 14.6.10 (7417)

## 5250 MHz System Verification at 17.0 dBm (50 mW)

**Area Scan (7x7x1):** Measurement grid: dx=10mm, dy=10mm

**Zoom Scan (8x8x7)/Cube 0:** Measurement grid: dx=4mm, dy=4mm, dz=1.4mm; Graded Ratio: 1.4

Peak SAR (extrapolated) = 15.8 W/kg

**SAR(1 g) = 3.7 W/kg**

Deviation(1 g) = -2.50%

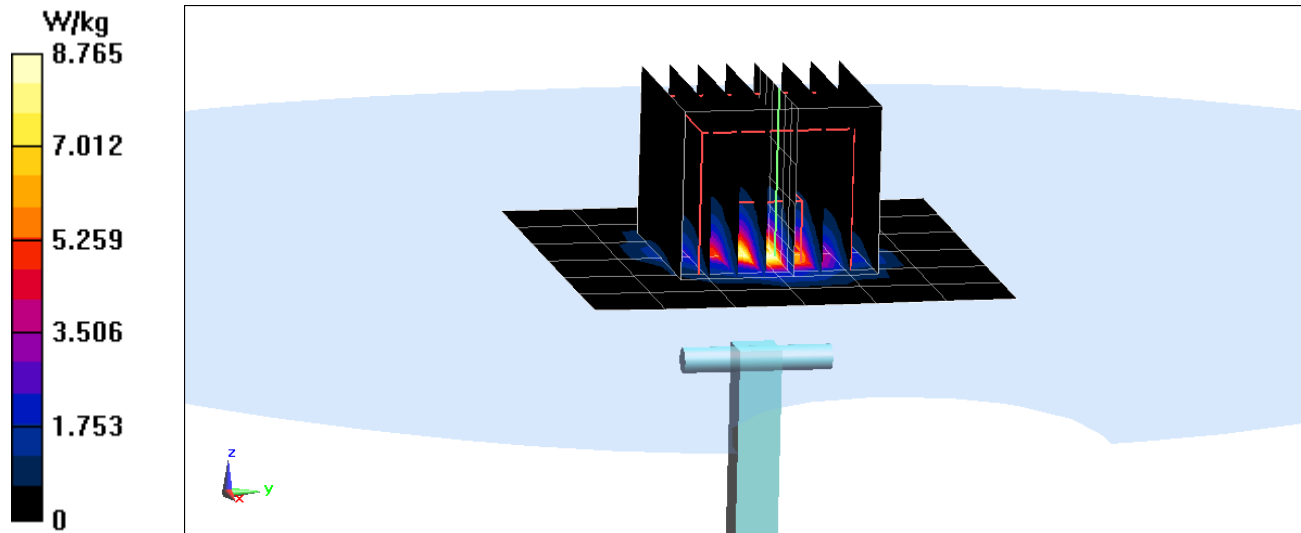

# PCTEST ENGINEERING LABORATORY, INC.

**DUT: Dipole 5 GHz; Type: D5GHzV2; Serial: 1123**

Communication System: UID 0, CW; Frequency: 5600 MHz; Duty Cycle: 1:1

Medium: 5 GHz Body Medium parameters used:

$f = 5600 \text{ MHz}$ ;  $\sigma = 5.877 \text{ S/m}$ ;  $\epsilon_r = 47.085$ ;  $\rho = 1000 \text{ kg/m}^3$

Phantom section: Flat Section; Space: 1.0 cm

Test Date: 07-24-2017; Ambient Temp: 22.1°C; Tissue Temp: 21.3°C

Probe: EX3DV4 - SN3589; ConvF(3.82, 3.82, 3.82); Calibrated: 1/13/2017;

Sensor-Surface: 1.4mm (Mechanical Surface Detection)

Electronics: DAE4 Sn1466; Calibrated: 1/16/2017

Phantom: SAM with CRP v5.0 Front; Type: QD000P40CD; Serial: 1646

Measurement SW: DASY52, Version 52.10; SEMCAD X Version 14.6.10 (7417)

## 5600 MHz System Verification at 17.0 dBm (50 mW)

**Area Scan (7x7x1):** Measurement grid: dx=10mm, dy=10mm

**Zoom Scan (8x8x7)/Cube 0:** Measurement grid: dx=4mm, dy=4mm, dz=1.4mm; Graded Ratio: 1.4

Peak SAR (extrapolated) = 18.4 W/kg

**SAR(1 g) = 4.07 W/kg**

Deviation(1 g) = 3.17%

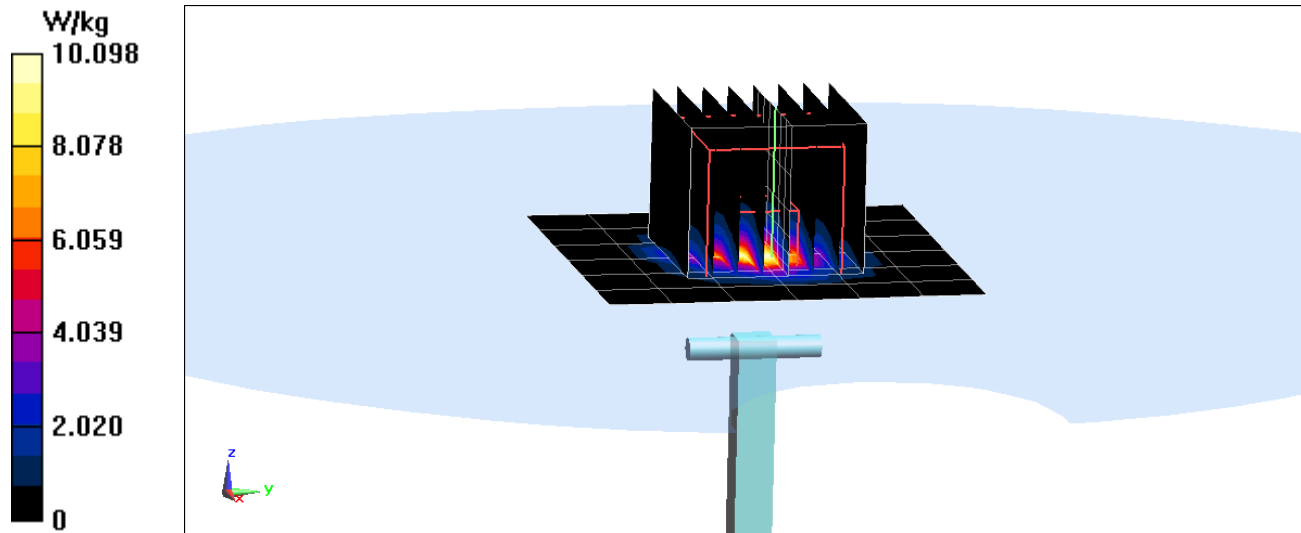

# PCTEST ENGINEERING LABORATORY, INC.

**DUT: Dipole 5 GHz; Type: D5GHzV2; Serial: 1123**

Communication System: UID 0, CW; Frequency: 5750 MHz; Duty Cycle: 1:1  
Medium: 5 GHz Body Medium parameters used (interpolated):  
 $f = 5750 \text{ MHz}$ ;  $\sigma = 6.087 \text{ S/m}$ ;  $\epsilon_r = 46.812$ ;  $\rho = 1000 \text{ kg/m}^3$   
Phantom section: Flat Section; Space: 1.0 cm

Test Date: 07-24-2017; Ambient Temp: 22.1°C; Tissue Temp: 21.3°C

Probe: EX3DV4 - SN3589; ConvF(3.83, 3.83, 3.83); Calibrated: 1/13/2017;  
Sensor-Surface: 1.4mm (Mechanical Surface Detection)

Electronics: DAE4 Sn1466; Calibrated: 1/16/2017

Phantom: SAM with CRP v5.0 Front; Type: QD000P40CD; Serial: 1646

Measurement SW: DASY52, Version 52.10; SEMCAD X Version 14.6.10 (7417)

## 5750 MHz System Verification at 17.0 dBm (50 mW)

**Area Scan (7x7x1):** Measurement grid: dx=10mm, dy=10mm

**Zoom Scan (8x8x7)/Cube 0:** Measurement grid: dx=4mm, dy=4mm, dz=1.4mm; Graded Ratio: 1.4

Peak SAR (extrapolated) = 17.4 W/kg

**SAR(1 g) = 3.81 W/kg**

Deviation(1 g) = -0.13%

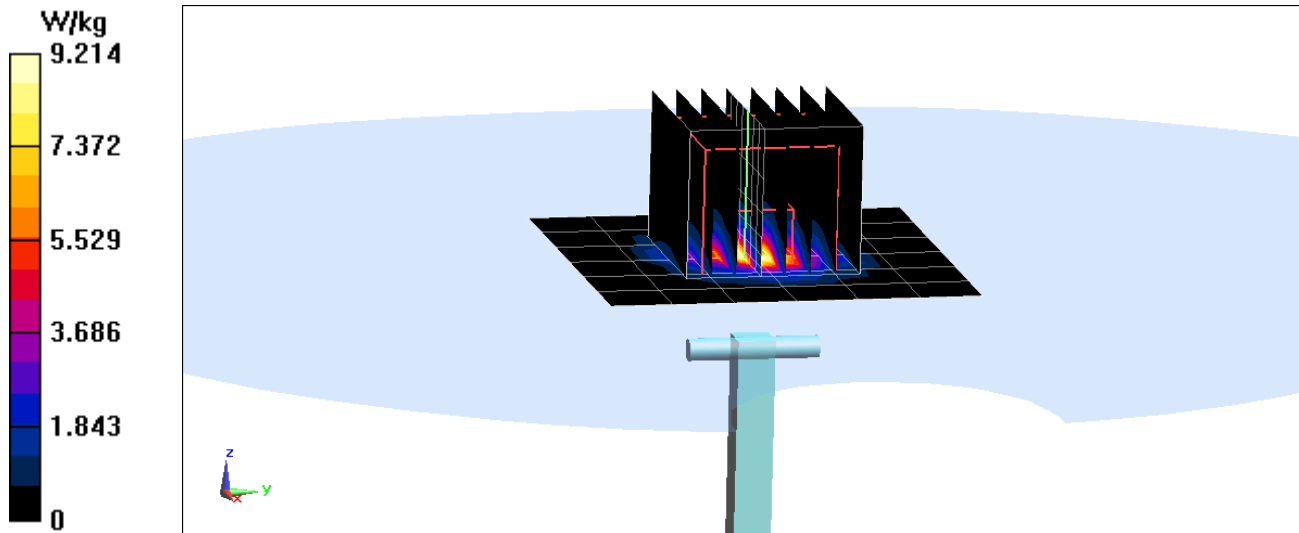

# PCTEST ENGINEERING LABORATORY, INC.

**DUT: Dipole 5 GHz; Type: D5GHzV2; Serial: 1123**

Communication System: UID 0, CW; Frequency: 5250 MHz; Duty Cycle: 1:1  
Medium: 5 GHz Body Medium parameters used (interpolated):  
 $f = 5250 \text{ MHz}$ ;  $\sigma = 5.467 \text{ S/m}$ ;  $\epsilon_r = 47.717$ ;  $\rho = 1000 \text{ kg/m}^3$   
Phantom section: Flat Section; Space: 1.0 cm

Test Date: 07-17-2017; Ambient Temp: 22.1°C; Tissue Temp: 21.0°C

Probe: EX3DV4 - SN3589; ConvF(4.19, 4.19, 4.19); Calibrated: 1/13/2017;  
Sensor-Surface: 1.4mm (Mechanical Surface Detection)  
Electronics: DAE4 Sn1466; Calibrated: 1/16/2017

Phantom: SAM with CRP v5.0 Front; Type: QD000P40CD; Serial: 1646  
Measurement SW: DASY52, Version 52.10; SEMCAD X Version 14.6.10 (7417)

## 5250 MHz System Verification at 17.0 dBm (50 mW)

**Area Scan (7x7x1):** Measurement grid: dx=10mm, dy=10mm

**Zoom Scan (8x8x7)/Cube 0:** Measurement grid: dx=4mm, dy=4mm, dz=1.4mm; Graded Ratio: 1.4

Peak SAR (extrapolated) = 16.0 W/kg

**SAR(10 g) = 1.05 W/kg**

Deviation(10 g) = -1.41%

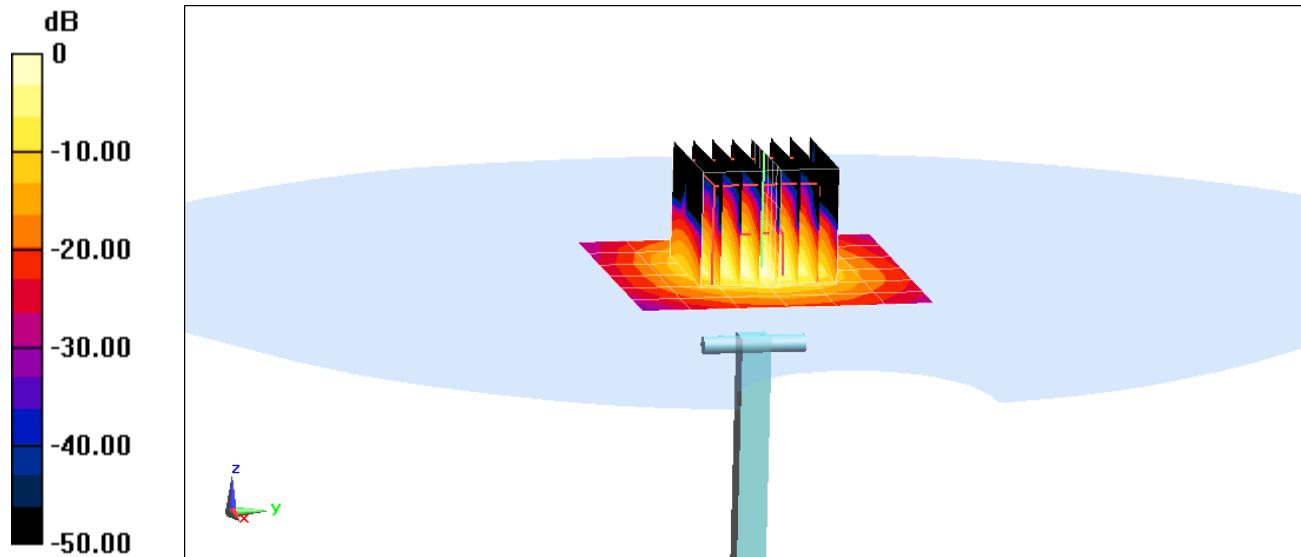

0 dB = 9.09 W/kg = 9.59 dBW/kg



# PCTEST ENGINEERING LABORATORY, INC.

**DUT: Dipole 5 GHz; Type: D5GHzV2; Serial: 1123**

Communication System: UID 0, CW; Frequency: 5600 MHz; Duty Cycle: 1:1

Medium: 5 GHz Body Medium parameters used:

$f = 5600 \text{ MHz}$ ;  $\sigma = 5.955 \text{ S/m}$ ;  $\epsilon_r = 47.069$ ;  $\rho = 1000 \text{ kg/m}^3$

Phantom section: Flat Section; Space: 1.0 cm

Test Date: 07-17-2017; Ambient Temp: 22.1°C; Tissue Temp: 21.0°C

Probe: EX3DV4 - SN3589; ConvF(3.82, 3.82, 3.82); Calibrated: 1/13/2017;

Sensor-Surface: 1.4mm (Mechanical Surface Detection)

Electronics: DAE4 Sn1466; Calibrated: 1/16/2017

Phantom: SAM with CRP v5.0 Front; Type: QD000P40CD; Serial: 1646

Measurement SW: DASY52, Version 52.10; SEMCAD X Version 14.6.10 (7417)

## 5600 MHz System Verification at 17.0 dBm (50 mW)

**Area Scan (7x7x1):** Measurement grid: dx=10mm, dy=10mm

**Zoom Scan (8x8x7)/Cube 0:** Measurement grid: dx=4mm, dy=4mm, dz=1.4mm; Graded Ratio: 1.4

Peak SAR (extrapolated) = 18.5 W/kg

**SAR(10 g) = 1.10 W/kg**

Deviation(10 g) = -0.45%

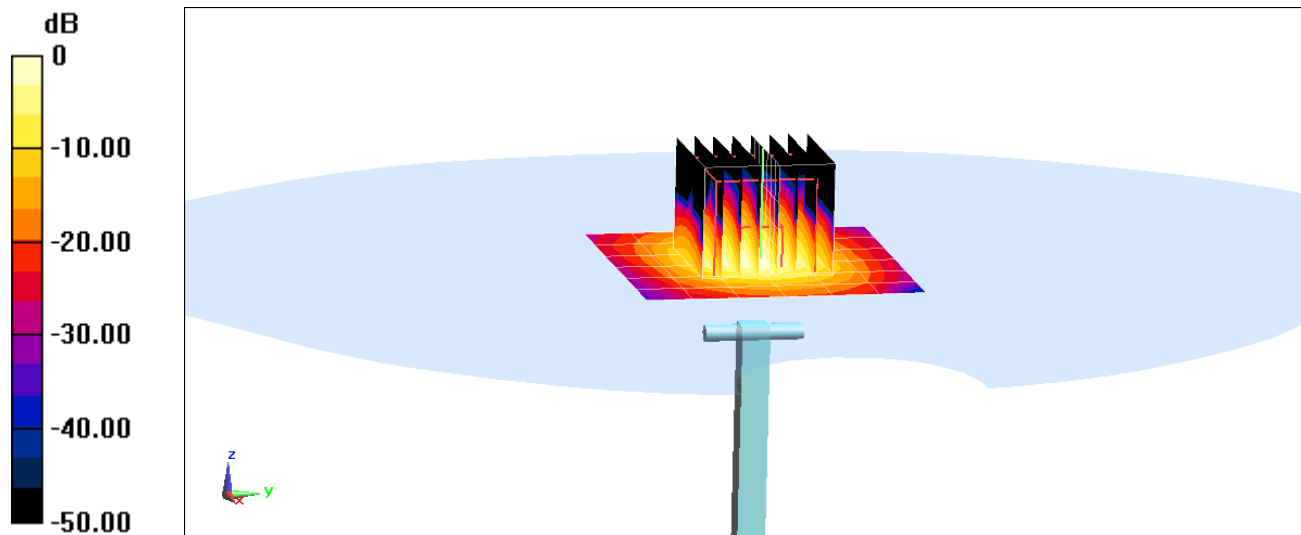

0 dB = 9.71 W/kg = 9.87 dBW/kg

## APPENDIX C: PROBE CALIBRATION



Accredited by the Swiss Accreditation Service (SAS)  
The Swiss Accreditation Service is one of the signatories to the EA  
Multilateral Agreement for the recognition of calibration certificates

Accreditation No.: **SCS 0108**

Client **PC Test**

Certificate No: **D750V3-1054\_Mar17**

## CALIBRATION CERTIFICATE

Object **D750V3 - SN:1054**

Calibration procedure(s) **QA CAL-05.v9**  
**Calibration procedure for dipole validation kits above 700 MHz**

*BNV*  
*03-27-2017*

Calibration date: **March 07, 2017**

This calibration certificate documents the traceability to national standards, which realize the physical units of measurements (SI).  
The measurements and the uncertainties with confidence probability are given on the following pages and are part of the certificate.

All calibrations have been conducted in the closed laboratory facility: environment temperature ( $22 \pm 3$ )°C and humidity < 70%.

Calibration Equipment used (M&TE critical for calibration)

Primary Standards	ID #	Cal Date (Certificate No.)	Scheduled Calibration
Power meter NRP	SN: 104778	06-Apr-16 (No. 217-02288/02289)	Apr-17
Power sensor NRP-Z91	SN: 103244	06-Apr-16 (No. 217-02288)	Apr-17
Power sensor NRP-Z91	SN: 103245	06-Apr-16 (No. 217-02289)	Apr-17
Reference 20 dB Attenuator	SN: 5058 (20k)	05-Apr-16 (No. 217-02292)	Apr-17
Type-N mismatch combination	SN: 5047.2 / 06327	05-Apr-16 (No. 217-02295)	Apr-17
Reference Probe EX3DV4	SN: 7349	31-Dec-16 (No. EX3-7349_Dec16)	Dec-17
DAE4	SN: 601	04-Jan-17 (No. DAE4-601_Jan17)	Jan-18

Secondary Standards	ID #	Check Date (in house)	Scheduled Check
Power meter EPM-442A	SN: GB37480704	07-Oct-15 (in house check Oct-16)	In house check: Oct-18
Power sensor HP 8481A	SN: US37292783	07-Oct-15 (in house check Oct-16)	In house check: Oct-18
Power sensor HP 8481A	SN: MY41092317	07-Oct-15 (in house check Oct-16)	In house check: Oct-18
RF generator R&S SMT-06	SN: 100972	15-Jun-15 (in house check Oct-16)	In house check: Oct-18
Network Analyzer HP 8753E	SN: US37390585	18-Oct-01 (in house check Oct-16)	In house check: Oct-17

Calibrated by: **Johannes Kurikka**      Function: **Laboratory Technician**

Signature: *Johannes Kurikka*

Approved by: **Katja Pokovic**      Technical Manager

Signature: *Katja Pokovic*

Issued: March 14, 2017

This calibration certificate shall not be reproduced except in full without written approval of the laboratory.



Accredited by the Swiss Accreditation Service (SAS)

The Swiss Accreditation Service is one of the signatories to the EA  
Multilateral Agreement for the recognition of calibration certificates

Accreditation No.: **SCS 0108**

### Glossary:

TSL	tissue simulating liquid
ConvF	sensitivity in TSL / NORM x,y,z
N/A	not applicable or not measured

### Calibration is Performed According to the Following Standards:

- IEEE Std 1528-2013, "IEEE Recommended Practice for Determining the Peak Spatial-Averaged Specific Absorption Rate (SAR) in the Human Head from Wireless Communications Devices: Measurement Techniques", June 2013
- IEC 62209-1, "Procedure to measure the Specific Absorption Rate (SAR) for hand-held devices used in close proximity to the ear (frequency range of 300 MHz to 3 GHz)", February 2005
- IEC 62209-2, "Procedure to determine the Specific Absorption Rate (SAR) for wireless communication devices used in close proximity to the human body (frequency range of 30 MHz to 6 GHz)", March 2010
- KDB 865664, "SAR Measurement Requirements for 100 MHz to 6 GHz"

### Additional Documentation:

- DASY4/5 System Handbook

### Methods Applied and Interpretation of Parameters:

- Measurement Conditions:** Further details are available from the Validation Report at the end of the certificate. All figures stated in the certificate are valid at the frequency indicated.
- Antenna Parameters with TSL:** The dipole is mounted with the spacer to position its feed point exactly below the center marking of the flat phantom section, with the arms oriented parallel to the body axis.
- Feed Point Impedance and Return Loss:** These parameters are measured with the dipole positioned under the liquid filled phantom. The impedance stated is transformed from the measurement at the SMA connector to the feed point. The Return Loss ensures low reflected power. No uncertainty required.
- Electrical Delay:** One-way delay between the SMA connector and the antenna feed point. No uncertainty required.
- SAR measured:** SAR measured at the stated antenna input power.
- SAR normalized:** SAR as measured, normalized to an input power of 1 W at the antenna connector.
- SAR for nominal TSL parameters:** The measured TSL parameters are used to calculate the nominal SAR result.

The reported uncertainty of measurement is stated as the standard uncertainty of measurement multiplied by the coverage factor  $k=2$ , which for a normal distribution corresponds to a coverage probability of approximately 95%.

## Measurement Conditions

DASY system configuration, as far as not given on page 1.

DASY Version	DASY5	V52.8.8
Extrapolation	Advanced Extrapolation	
Phantom	Modular Flat Phantom	
Distance Dipole Center - TSL	15 mm	with Spacer
Zoom Scan Resolution	dx, dy, dz = 5 mm	
Frequency	750 MHz ± 1 MHz	

## Head TSL parameters

The following parameters and calculations were applied.

	Temperature	Permittivity	Conductivity
Nominal Head TSL parameters	22.0 °C	41.9	0.89 mho/m
Measured Head TSL parameters	(22.0 ± 0.2) °C	40.9 ± 6 %	0.91 mho/m ± 6 %
Head TSL temperature change during test	< 0.5 °C	----	----

## SAR result with Head TSL

SAR averaged over 1 cm <sup>3</sup> (1 g) of Head TSL	Condition	
SAR measured	250 mW input power	2.14 W/kg
SAR for nominal Head TSL parameters	normalized to 1W	<b>8.37 W/kg ± 17.0 % (k=2)</b>

SAR averaged over 10 cm <sup>3</sup> (10 g) of Head TSL	condition	
SAR measured	250 mW input power	1.40 W/kg
SAR for nominal Head TSL parameters	normalized to 1W	<b>5.50 W/kg ± 16.5 % (k=2)</b>

## Body TSL parameters

The following parameters and calculations were applied.

	Temperature	Permittivity	Conductivity
Nominal Body TSL parameters	22.0 °C	55.5	0.96 mho/m
Measured Body TSL parameters	(22.0 ± 0.2) °C	54.6 ± 6 %	0.99 mho/m ± 6 %
Body TSL temperature change during test	< 0.5 °C	----	----

## SAR result with Body TSL

SAR averaged over 1 cm <sup>3</sup> (1 g) of Body TSL	Condition	
SAR measured	250 mW input power	2.21 W/kg
SAR for nominal Body TSL parameters	normalized to 1W	<b>8.61 W/kg ± 17.0 % (k=2)</b>

SAR averaged over 10 cm <sup>3</sup> (10 g) of Body TSL	condition	
SAR measured	250 mW input power	1.45 W/kg
SAR for nominal Body TSL parameters	normalized to 1W	<b>5.68 W/kg ± 16.5 % (k=2)</b>

## Appendix (Additional assessments outside the scope of SCS 0108)

### Antenna Parameters with Head TSL

Impedance, transformed to feed point	54.7 $\Omega$ - 0.7 j $\Omega$
Return Loss	- 26.8 dB

### Antenna Parameters with Body TSL

Impedance, transformed to feed point	50.7 $\Omega$ - 3.6 j $\Omega$
Return Loss	- 28.7 dB

### General Antenna Parameters and Design

Electrical Delay (one direction)	1.033 ns
----------------------------------	----------

After long term use with 100W radiated power, only a slight warming of the dipole near the feedpoint can be measured.

The dipole is made of standard semirigid coaxial cable. The center conductor of the feeding line is directly connected to the second arm of the dipole. The antenna is therefore short-circuited for DC-signals. On some of the dipoles, small end caps are added to the dipole arms in order to improve matching when loaded according to the position as explained in the "Measurement Conditions" paragraph. The SAR data are not affected by this change. The overall dipole length is still according to the Standard.

No excessive force must be applied to the dipole arms, because they might bend or the soldered connections near the feedpoint may be damaged.

### Additional EUT Data

Manufactured by	SPEAG
Manufactured on	November 08, 2011

# DASY5 Validation Report for Head TSL

Date: 07.03.2017

Test Laboratory: SPEAG, Zurich, Switzerland

**DUT: Dipole 750 MHz; Type: D750V3; Serial: D750V3 - SN:1054**

Communication System: UID 0 - CW ; Frequency: 750 MHz

Medium parameters used:  $f = 750 \text{ MHz}$ ;  $\sigma = 0.91 \text{ S/m}$ ;  $\epsilon_r = 40.9$ ;  $\rho = 1000 \text{ kg/m}^3$

Phantom section: Flat Section

Measurement Standard: DASY5 (IEEE/IEC/ANSI C63.19-2011)

DASY52 Configuration:

- Probe: EX3DV4 - SN7349; ConvF(10.17, 10.17, 10.17); Calibrated: 31.12.2016;
- Sensor-Surface: 1.4mm (Mechanical Surface Detection)
- Electronics: DAE4 Sn601; Calibrated: 04.01.2017
- Phantom: Flat Phantom 4.9 (front); Type: QD 00L P49 AA; Serial: 1001
- DASY52 52.8.8(1222); SEMCAD X 14.6.10(7331)

## Dipole Calibration for Head Tissue/Pin=250 mW, d=15mm/Zoom Scan (7x7x7)/Cube 0:

Measurement grid: dx=5mm, dy=5mm, dz=5mm

Reference Value = 59.71 V/m; Power Drift = 0.01 dB

Peak SAR (extrapolated) = 3.21 W/kg

**SAR(1 g) = 2.14 W/kg; SAR(10 g) = 1.4 W/kg**

Maximum value of SAR (measured) = 2.85 W/kg

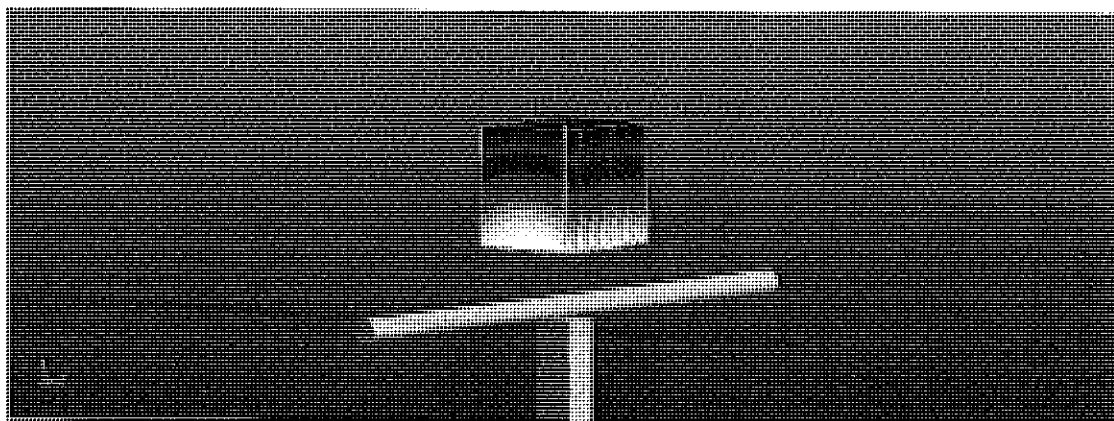
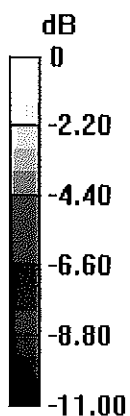

0 dB = 2.85 W/kg = 4.55 dBW/kg

# Impedance Measurement Plot for Head TSL

7 Mar 2017 12:25:14

CH1 S11 1 U FS

1: 54.732  $\Omega$  -732.42 m $\Omega$  289.73 pF

750.000 000 MHz

\*  
De1  
Ca

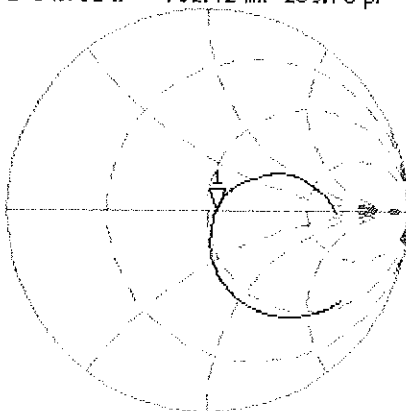

Avg  
16

H1d

CH2 S11 LOG

5 dB/REF -20 dB

1:-26.788 dB

750.000 000 MHz

Ca

Avg  
16

H1d

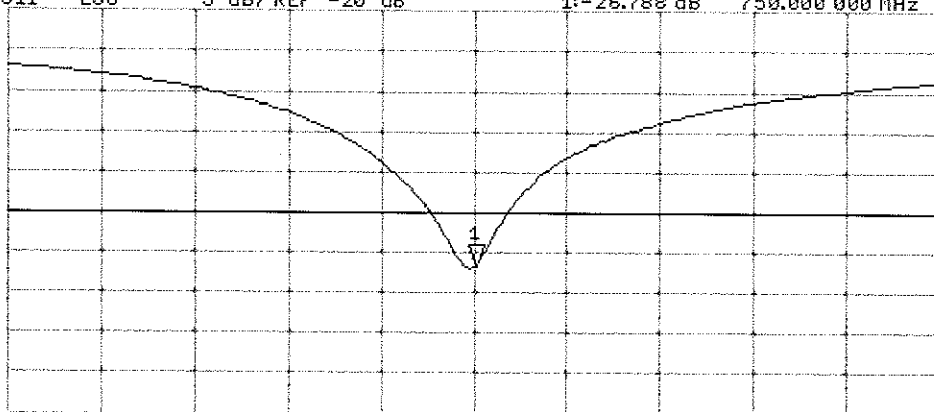

START 550.000 000 MHz

STOP 950.000 000 MHz



## DASY5 Validation Report for Body TSL

Date: 07.03.2017

Test Laboratory: SPEAG, Zurich, Switzerland

**DUT: Dipole 750 MHz; Type: D750V3; Serial: D750V3 - SN:1054**

Communication System: UID 0 - CW ; Frequency: 750 MHz

Medium parameters used:  $f = 750$  MHz;  $\sigma = 0.99$  S/m;  $\epsilon_r = 54.6$ ;  $\rho = 1000$  kg/m<sup>3</sup>

Phantom section: Flat Section

Measurement Standard: DASY5 (IEEE/IEC/ANSI C63.19-2011)

DASY52 Configuration:

- Probe: EX3DV4 - SN7349; ConvF(9.99, 9.99, 9.99); Calibrated: 31.12.2016;
- Sensor-Surface: 1.4mm (Mechanical Surface Detection)
- Electronics: DAE4 Sn601; Calibrated: 04.01.2017
- Phantom: Flat Phantom 4.9 (Back); Type: QD 00R P49 AA; Serial: 1005
- DASY52 52.8.8(1222); SEMCAD X 14.6.10(7331)

### Dipole Calibration for Body Tissue/Pin=250 mW, d=15mm/Zoom Scan (7x7x7)/Cube 0:

Measurement grid: dx=5mm, dy=5mm, dz=5mm

Reference Value = 57.88 V/m; Power Drift = -0.01 dB

Peak SAR (extrapolated) = 3.31 W/kg

**SAR(1 g) = 2.21 W/kg; SAR(10 g) = 1.45 W/kg**

Maximum value of SAR (measured) = 2.94 W/kg

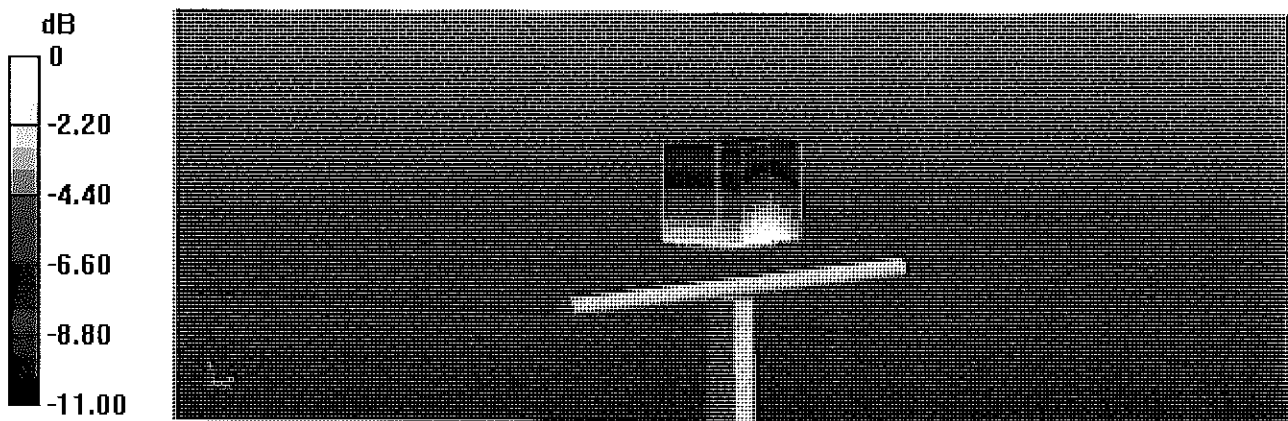

# Impedance Measurement Plot for Body TSL

7 Mar 2017 11:51:37  
S11 1 U FS 1: 50.666  $\Omega$  -3.6309  $\Omega$  58.445 pF 750.000 000 MHz

\*  
De1  
CA

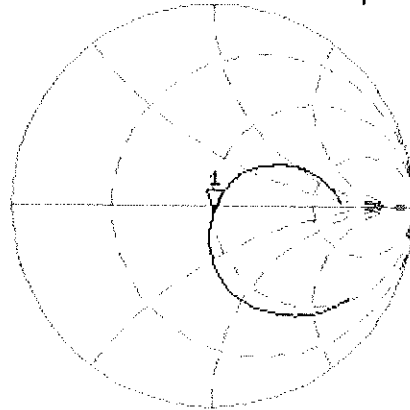

Avg  
16

H1d

CH2 S11 LOG 5 dB/REF -20 dB 1:-28.716 dB 750.000 000 MHz

CA

Avg  
16

H1d

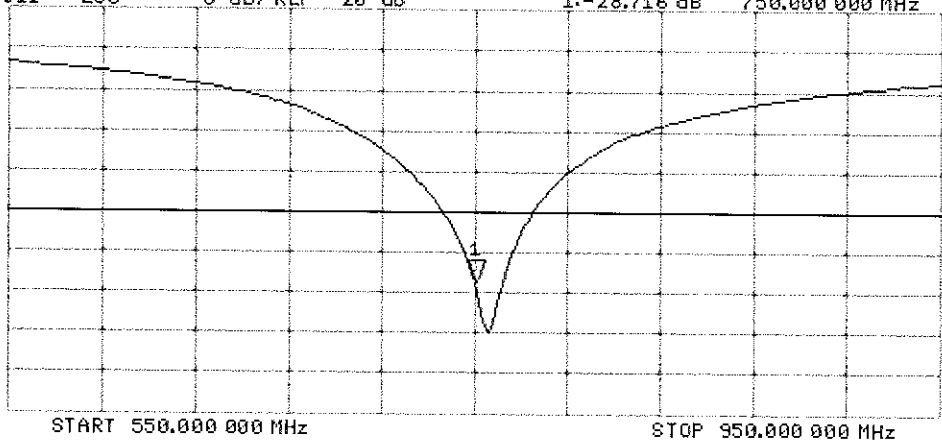



Accredited by the Swiss Accreditation Service (SAS)  
The Swiss Accreditation Service is one of the signatories to the EA  
Multilateral Agreement for the recognition of calibration certificates

Accreditation No.: **SCS 0108**

Client **PC Test**

Certificate No: **D835V2-4d180\_May17**

## CALIBRATION CERTIFICATE

Object **D835V2 - SN:4d180**

Calibration procedure(s) **QA CAL-05.v9**  
**Calibration procedure for dipole validation kits above 700 MHz**

Calibration date: **May 11, 2017**

*BNV*  
*05-23-2017*

This calibration certificate documents the traceability to national standards, which realize the physical units of measurements (SI).  
The measurements and the uncertainties with confidence probability are given on the following pages and are part of the certificate.

All calibrations have been conducted in the closed laboratory facility: environment temperature  $(22 \pm 3)^\circ\text{C}$  and humidity  $< 70\%$ .

Calibration Equipment used (M&TE critical for calibration)

Primary Standards	ID #	Cal Date (Certificate No.)	Scheduled Calibration
Power meter NRP	SN: 104778	04-Apr-17 (No. 217-02521/02522)	Apr-18
Power sensor NRP-Z91	SN: 103244	04-Apr-17 (No. 217-02521)	Apr-18
Power sensor NRP-Z91	SN: 103245	04-Apr-17 (No. 217-02522)	Apr-18
Reference 20 dB Attenuator	SN: 5058 (20k)	07-Apr-17 (No. 217-02528)	Apr-18
Type-N mismatch combination	SN: 5047.2 / 06327	07-Apr-17 (No. 217-02529)	Apr-18
Reference Probe EX3DV4	SN: 7349	31-Dec-16 (No. EX3-7349_Dec16)	Dec-17
DAE4	SN: 601	28-Mar-17 (No. DAE4-601_Mar17)	Mar-18

Secondary Standards	ID #	Check Date (in house)	Scheduled Check
Power meter EPM-442A	SN: GB37480704	07-Oct-15 (in house check Oct-16)	In house check: Oct-18
Power sensor HP 8481A	SN: US37292783	07-Oct-15 (in house check Oct-16)	In house check: Oct-18
Power sensor HP 8481A	SN: MY41092317	07-Oct-15 (in house check Oct-16)	In house check: Oct-18
RF generator R&S SMT-06	SN: 100972	15-Jun-15 (in house check Oct-16)	In house check: Oct-18
Network Analyzer HP 8753E	SN: US37390585	18-Oct-01 (in house check Oct-16)	In house check: Oct-17

Calibrated by: **Johannes Kurikka**      Function: **Laboratory Technician**

Approved by: **Katja Pokovic**      Technical Manager

Signature

*Johannes Kurikka*  
*Katja Pokovic*

Issued: May 11, 2017

This calibration certificate shall not be reproduced except in full without written approval of the laboratory.



Accredited by the Swiss Accreditation Service (SAS)  
The Swiss Accreditation Service is one of the signatories to the EA  
Multilateral Agreement for the recognition of calibration certificates

Accreditation No.: **SCS 0108**

### Glossary:

TSL	tissue simulating liquid
ConvF	sensitivity in TSL / NORM x,y,z
N/A	not applicable or not measured

### Calibration is Performed According to the Following Standards:

- IEEE Std 1528-2013, "IEEE Recommended Practice for Determining the Peak Spatial-Averaged Specific Absorption Rate (SAR) in the Human Head from Wireless Communications Devices: Measurement Techniques", June 2013
- IEC 62209-1, "Procedure to measure the Specific Absorption Rate (SAR) for hand-held devices used in close proximity to the ear (frequency range of 300 MHz to 3 GHz)", February 2005
- IEC 62209-2, "Procedure to determine the Specific Absorption Rate (SAR) for wireless communication devices used in close proximity to the human body (frequency range of 30 MHz to 6 GHz)", March 2010
- KDB 865664, "SAR Measurement Requirements for 100 MHz to 6 GHz"

### Additional Documentation:

- DASY4/5 System Handbook

### Methods Applied and Interpretation of Parameters:

- Measurement Conditions:** Further details are available from the Validation Report at the end of the certificate. All figures stated in the certificate are valid at the frequency indicated.
- Antenna Parameters with TSL:** The dipole is mounted with the spacer to position its feed point exactly below the center marking of the flat phantom section, with the arms oriented parallel to the body axis.
- Feed Point Impedance and Return Loss:** These parameters are measured with the dipole positioned under the liquid filled phantom. The impedance stated is transformed from the measurement at the SMA connector to the feed point. The Return Loss ensures low reflected power. No uncertainty required.
- Electrical Delay:** One-way delay between the SMA connector and the antenna feed point. No uncertainty required.
- SAR measured:** SAR measured at the stated antenna input power.
- SAR normalized:** SAR as measured, normalized to an input power of 1 W at the antenna connector.
- SAR for nominal TSL parameters:** The measured TSL parameters are used to calculate the nominal SAR result.

The reported uncertainty of measurement is stated as the standard uncertainty of measurement multiplied by the coverage factor  $k=2$ , which for a normal distribution corresponds to a coverage probability of approximately 95%.

## Measurement Conditions

DASY system configuration, as far as not given on page 1.

DASY Version	DASY5	V52.10.0
Extrapolation	Advanced Extrapolation	
Phantom	Modular Flat Phantom	
Distance Dipole Center - TSL	15 mm	with Spacer
Zoom Scan Resolution	dx, dy, dz = 5 mm	
Frequency	835 MHz $\pm$ 1 MHz	

## Head TSL parameters

The following parameters and calculations were applied.

	Temperature	Permittivity	Conductivity
Nominal Head TSL parameters	22.0 °C	41.5	0.90 mho/m
Measured Head TSL parameters	(22.0 $\pm$ 0.2) °C	40.8 $\pm$ 6 %	0.94 mho/m $\pm$ 6 %
Head TSL temperature change during test	< 0.5 °C	----	----

## SAR result with Head TSL

SAR averaged over 1 cm <sup>3</sup> (1 g) of Head TSL	Condition	
SAR measured	250 mW input power	2.40 W/kg
SAR for nominal Head TSL parameters	normalized to 1W	<b>9.26 W/kg <math>\pm</math> 17.0 % (k=2)</b>

SAR averaged over 10 cm <sup>3</sup> (10 g) of Head TSL	condition	
SAR measured	250 mW input power	1.56 W/kg
SAR for nominal Head TSL parameters	normalized to 1W	<b>6.07 W/kg <math>\pm</math> 16.5 % (k=2)</b>

## Body TSL parameters

The following parameters and calculations were applied.

	Temperature	Permittivity	Conductivity
Nominal Body TSL parameters	22.0 °C	55.2	0.97 mho/m
Measured Body TSL parameters	(22.0 $\pm$ 0.2) °C	55.2 $\pm$ 6 %	0.99 mho/m $\pm$ 6 %
Body TSL temperature change during test	< 0.5 °C	----	----

## SAR result with Body TSL

SAR averaged over 1 cm <sup>3</sup> (1 g) of Body TSL	Condition	
SAR measured	250 mW input power	2.44 W/kg
SAR for nominal Body TSL parameters	normalized to 1W	<b>9.61 W/kg <math>\pm</math> 17.0 % (k=2)</b>

SAR averaged over 10 cm <sup>3</sup> (10 g) of Body TSL	condition	
SAR measured	250 mW input power	1.60 W/kg
SAR for nominal Body TSL parameters	normalized to 1W	<b>6.32 W/kg <math>\pm</math> 16.5 % (k=2)</b>

## Appendix (Additional assessments outside the scope of SCS 0108)

### Antenna Parameters with Head TSL

Impedance, transformed to feed point	51.9 $\Omega$ - 5.0 j $\Omega$
Return Loss	- 25.6 dB

### Antenna Parameters with Body TSL

Impedance, transformed to feed point	46.7 $\Omega$ - 8.6 j $\Omega$
Return Loss	- 20.5 dB

### General Antenna Parameters and Design

Electrical Delay (one direction)	1.393 ns
----------------------------------	----------

After long term use with 100W radiated power, only a slight warming of the dipole near the feedpoint can be measured.

The dipole is made of standard semirigid coaxial cable. The center conductor of the feeding line is directly connected to the second arm of the dipole. The antenna is therefore short-circuited for DC-signals. On some of the dipoles, small end caps are added to the dipole arms in order to improve matching when loaded according to the position as explained in the "Measurement Conditions" paragraph. The SAR data are not affected by this change. The overall dipole length is still according to the Standard.

No excessive force must be applied to the dipole arms, because they might bend or the soldered connections near the feedpoint may be damaged.

### Additional EUT Data

Manufactured by	SPEAG
Manufactured on	September 24, 2014

## DASY5 Validation Report for Head TSL

Date: 11.05.2017

Test Laboratory: SPEAG, Zurich, Switzerland

**DUT: Dipole 835 MHz; Type: D835V2; Serial: D835V2 - SN:4d180**

Communication System: UID 0 - CW; Frequency: 835 MHz

Medium parameters used:  $f = 835$  MHz;  $\sigma = 0.94$  S/m;  $\epsilon_r = 40.8$ ;  $\rho = 1000$  kg/m<sup>3</sup>

Phantom section: Flat Section

Measurement Standard: DASY5 (IEEE/IEC/ANSI C63.19-2011)

DASY52 Configuration:

- Probe: EX3DV4 - SN7349; ConvF(9.72, 9.72, 9.72); Calibrated: 31.12.2016;
- Sensor-Surface: 1.4mm (Mechanical Surface Detection)
- Electronics: DAE4 Sn601; Calibrated: 28.03.2017
- Phantom: Flat Phantom 4.9 (front); Type: QD 00L P49 AA; Serial: 1001
- DASY52 52.10.0(1444); SEMCAD X 14.6.10(7416)

### Dipole Calibration for Head Tissue/Pin=250 mW, d=15mm/Zoom Scan (7x7x7)/Cube 0:

Measurement grid: dx=5mm, dy=5mm, dz=5mm

Reference Value = 62.02 V/m; Power Drift = -0.02 dB

Peak SAR (extrapolated) = 3.58 W/kg

**SAR(1 g) = 2.4 W/kg; SAR(10 g) = 1.56 W/kg**

Maximum value of SAR (measured) = 3.21 W/kg

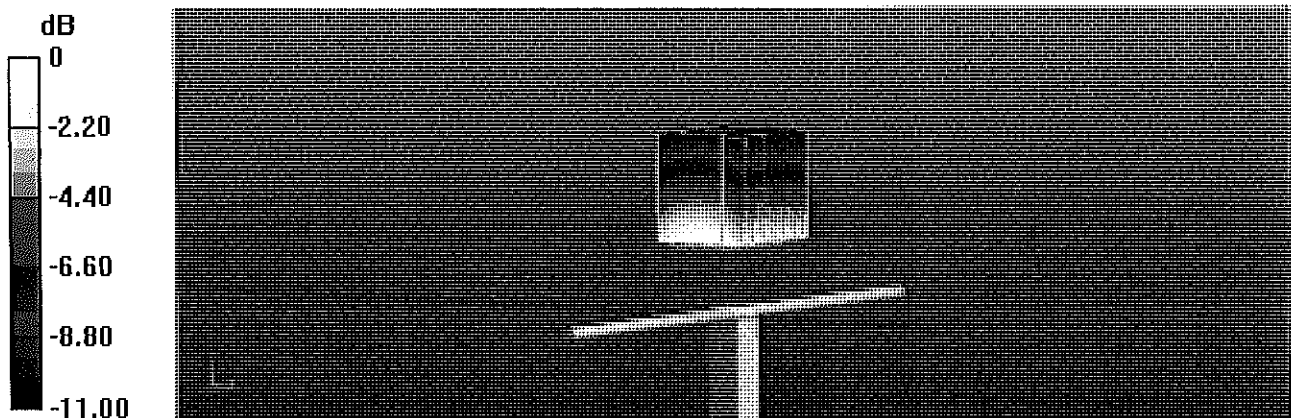

0 dB = 3.21 W/kg = 5.07 dBW/kg

# Impedance Measurement Plot for Head TSL

11 May 2017 14:53:56  
 CH1 S11 1 U FS 1: 51.861  $\Omega$  -5.0117  $\Omega$  38.032  $\mu$ F 835.000 000 MHz

\*  
 Del  
 CA  
 Avg  
 16  
 H1d

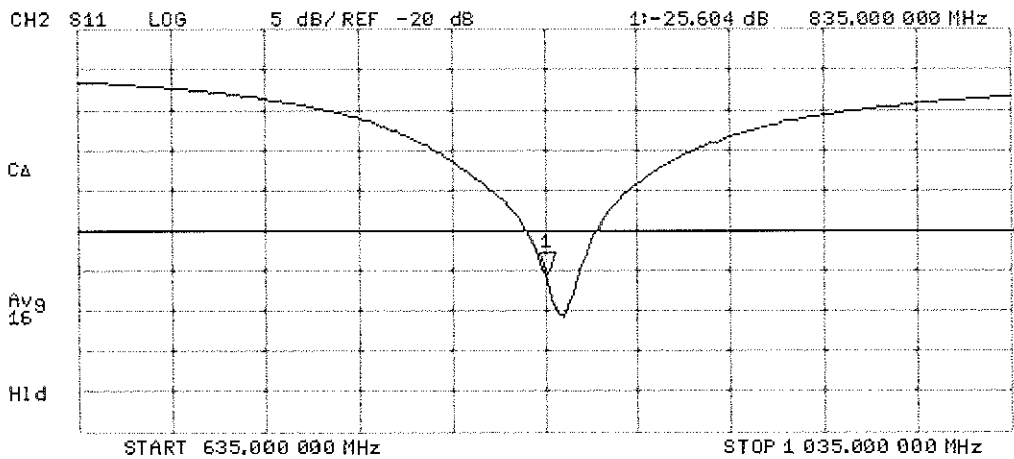
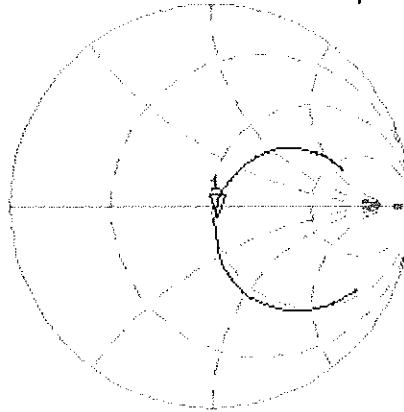



## DASY5 Validation Report for Body TSL

Date: 11.05.2017

Test Laboratory: SPEAG, Zurich, Switzerland

**DUT: Dipole 835 MHz; Type: D835V2; Serial: D835V2 - SN:4d180**

Communication System: UID 0 - CW; Frequency: 835 MHz

Medium parameters used:  $f = 835$  MHz;  $\sigma = 0.99$  S/m;  $\epsilon_r = 55.2$ ;  $\rho = 1000$  kg/m<sup>3</sup>

Phantom section: Flat Section

Measurement Standard: DASY5 (IEEE/IEC/ANSI C63.19-2011)

DASY52 Configuration:

- Probe: EX3DV4 - SN7349; ConvF(9.73, 9.73, 9.73); Calibrated: 31.12.2016;
- Sensor-Surface: 1.4mm (Mechanical Surface Detection)
- Electronics: DAE4 Sn601; Calibrated: 28.03.2017
- Phantom: Flat Phantom 4.9 (Back); Type: QD 00R P49 AA; Serial: 1005
- DASY52 52.10.0(1444); SEMCAD X 14.6.10(7416)

### Dipole Calibration for Body Tissue/Pin=250 mW, d=15mm/Zoom Scan (7x7x7)/Cube 0:

Measurement grid: dx=5mm, dy=5mm, dz=5mm

Reference Value = 60.10 V/m; Power Drift = -0.01 dB

Peak SAR (extrapolated) = 3.58 W/kg

**SAR(1 g) = 2.44 W/kg; SAR(10 g) = 1.6 W/kg**

Maximum value of SAR (measured) = 3.19 W/kg

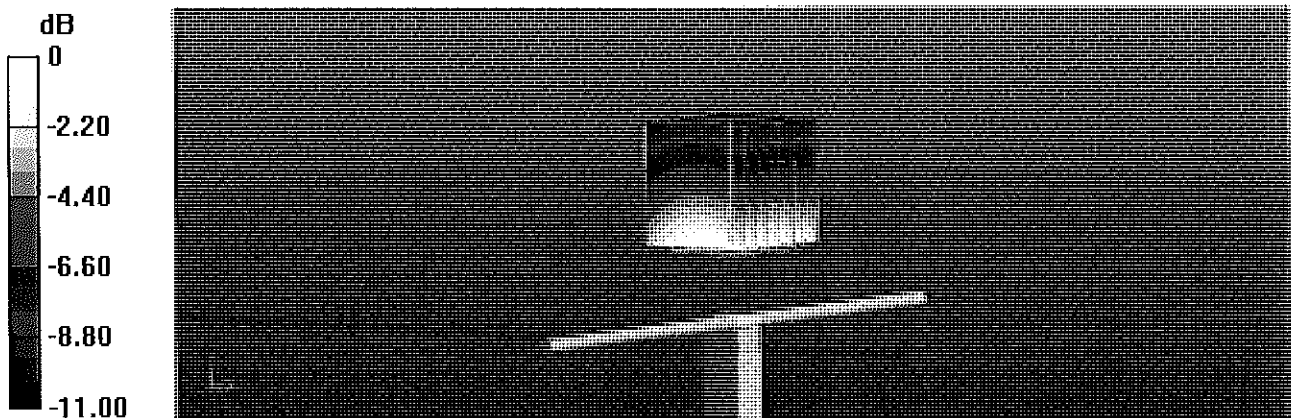

0 dB = 3.19 W/kg = 5.04 dBW/kg

# Impedance Measurement Plot for Body TSL

11 May 2017 14:30:26  
[CH1] S11 1 U FS 1: 46.727  $\Omega$  -8.5898  $\Omega$  22.190  $\mu$ F 835.000 000 MHz

\*  
De1  
CA  
Avg  
16  
H1d

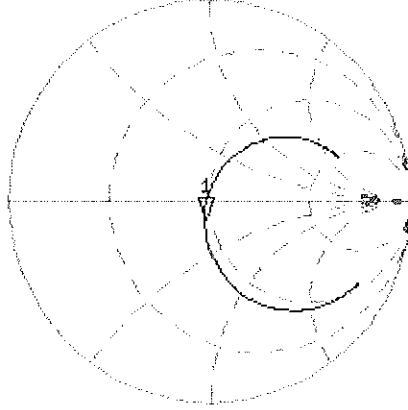

CH2 S11 LOG 5 dB/REF -20 dB 1: -20.477 dB 835.000 000 MHz

CA  
Avg  
16  
H1d

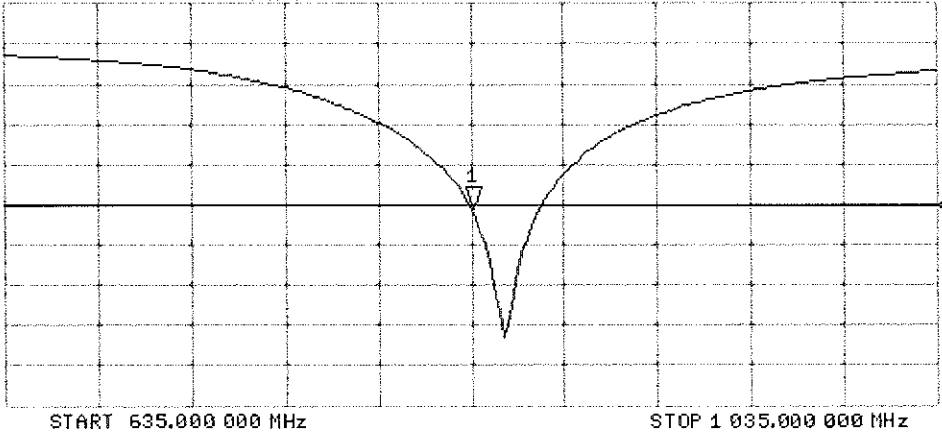



Accredited by the Swiss Accreditation Service (SAS)  
The Swiss Accreditation Service is one of the signatories to the EA  
Multilateral Agreement for the recognition of calibration certificates

Accreditation No.: **SCS 0108**

Client **PC Test**

Certificate No: **D1750V2-1092\_May17**

## CALIBRATION CERTIFICATE

Object **D1750V2 - SN:1092**

Calibration procedure(s) **QA CAL-05.v9  
Calibration procedure for dipole validation kits above 700 MHz**

Calibration date: **May 09, 2017**

*BN ✓*  
*05-23-2017*

This calibration certificate documents the traceability to national standards, which realize the physical units of measurements (SI).  
The measurements and the uncertainties with confidence probability are given on the following pages and are part of the certificate.

All calibrations have been conducted in the closed laboratory facility: environment temperature  $(22 \pm 3)^\circ\text{C}$  and humidity  $< 70\%$ .

Calibration Equipment used (M&TE critical for calibration)

Primary Standards	ID #	Cal Date (Certificate No.)	Scheduled Calibration
Power meter NRP	SN: 104778	04-Apr-17 (No. 217-02521/02522)	Apr-18
Power sensor NRP-Z91	SN: 103244	04-Apr-17 (No. 217-02521)	Apr-18
Power sensor NRP-Z91	SN: 103245	04-Apr-17 (No. 217-02522)	Apr-18
Reference 20 dB Attenuator	SN: 5058 (20k)	07-Apr-17 (No. 217-02528)	Apr-18
Type-N mismatch combination	SN: 5047.2 / 06327	07-Apr-17 (No. 217-02529)	Apr-18
Reference Probe EX3DV4	SN: 7349	31-Dec-16 (No. EX3-7349_Dec16)	Dec-17
DAE4	SN: 601	28-Mar-17 (No. DAE4-601_Mar17)	Mar-18
Secondary Standards	ID #	Check Date (in house)	Scheduled Check
Power meter EPM-442A	SN: GB37480704	07-Oct-15 (in house check Oct-16)	In house check: Oct-18
Power sensor HP 8481A	SN: US37292783	07-Oct-15 (in house check Oct-16)	In house check: Oct-18
Power sensor HP 8481A	SN: MY41092317	07-Oct-15 (in house check Oct-16)	In house check: Oct-18
RF generator R&S SMT-06	SN: 100972	15-Jun-15 (in house check Oct-16)	In house check: Oct-18
Network Analyzer HP 8753E	SN: US37390585	18-Oct-01 (in house check Oct-16)	In house check: Oct-17

Calibrated by: **Claudio Leubler**      **Laboratory Technician**

Signature

Approved by: **Katja Pokovic**      **Technical Manager**

Issued: May 11, 2017

This calibration certificate shall not be reproduced except in full without written approval of the laboratory.



Accredited by the Swiss Accreditation Service (SAS)

Accreditation No.: **SCS 0108**

The Swiss Accreditation Service is one of the signatories to the EA Multilateral Agreement for the recognition of calibration certificates

### Glossary:

TSL	tissue simulating liquid
ConvF	sensitivity in TSL / NORM x,y,z
N/A	not applicable or not measured

### Calibration is Performed According to the Following Standards:

- IEEE Std 1528-2013, "IEEE Recommended Practice for Determining the Peak Spatial-Averaged Specific Absorption Rate (SAR) in the Human Head from Wireless Communications Devices: Measurement Techniques", June 2013
- IEC 62209-1, "Procedure to measure the Specific Absorption Rate (SAR) for hand-held devices used in close proximity to the ear (frequency range of 300 MHz to 3 GHz)", February 2005
- IEC 62209-2, "Procedure to determine the Specific Absorption Rate (SAR) for wireless communication devices used in close proximity to the human body (frequency range of 30 MHz to 6 GHz)", March 2010
- KDB 865664, "SAR Measurement Requirements for 100 MHz to 6 GHz"

### Additional Documentation:

- DASY4/5 System Handbook

### Methods Applied and Interpretation of Parameters:

- Measurement Conditions:** Further details are available from the Validation Report at the end of the certificate. All figures stated in the certificate are valid at the frequency indicated.
- Antenna Parameters with TSL:** The dipole is mounted with the spacer to position its feed point exactly below the center marking of the flat phantom section, with the arms oriented parallel to the body axis.
- Feed Point Impedance and Return Loss:** These parameters are measured with the dipole positioned under the liquid filled phantom. The impedance stated is transformed from the measurement at the SMA connector to the feed point. The Return Loss ensures low reflected power. No uncertainty required.
- Electrical Delay:** One-way delay between the SMA connector and the antenna feed point. No uncertainty required.
- SAR measured:** SAR measured at the stated antenna input power.
- SAR normalized:** SAR as measured, normalized to an input power of 1 W at the antenna connector.
- SAR for nominal TSL parameters:** The measured TSL parameters are used to calculate the nominal SAR result.

The reported uncertainty of measurement is stated as the standard uncertainty of measurement multiplied by the coverage factor  $k=2$ , which for a normal distribution corresponds to a coverage probability of approximately 95%.

## Measurement Conditions

DASY system configuration, as far as not given on page 1.

<b>DASY Version</b>	DASY5	V52.10.0
<b>Extrapolation</b>	Advanced Extrapolation	
<b>Phantom</b>	Modular Flat Phantom	
<b>Distance Dipole Center - TSL</b>	10 mm	with Spacer
<b>Zoom Scan Resolution</b>	dx, dy, dz = 5 mm	
<b>Frequency</b>	1750 MHz $\pm$ 1 MHz	

## Head TSL parameters

The following parameters and calculations were applied.

	Temperature	Permittivity	Conductivity
<b>Nominal Head TSL parameters</b>	22.0 °C	40.1	1.37 mho/m
<b>Measured Head TSL parameters</b>	(22.0 $\pm$ 0.2) °C	39.0 $\pm$ 6 %	1.36 mho/m $\pm$ 6 %
<b>Head TSL temperature change during test</b>	< 0.5 °C	----	----

## SAR result with Head TSL

<b>SAR averaged over 1 cm<sup>3</sup> (1 g) of Head TSL</b>	Condition	
SAR measured	250 mW input power	9.11 W/kg
SAR for nominal Head TSL parameters	normalized to 1W	<b>36.4 W/kg <math>\pm</math> 17.0 % (k=2)</b>

<b>SAR averaged over 10 cm<sup>3</sup> (10 g) of Head TSL</b>	condition	
SAR measured	250 mW input power	4.83 W/kg
SAR for nominal Head TSL parameters	normalized to 1W	<b>19.3 W/kg <math>\pm</math> 16.5 % (k=2)</b>

## Body TSL parameters

The following parameters and calculations were applied.

	Temperature	Permittivity	Conductivity
<b>Nominal Body TSL parameters</b>	22.0 °C	53.4	1.49 mho/m
<b>Measured Body TSL parameters</b>	(22.0 $\pm$ 0.2) °C	53.7 $\pm$ 6 %	1.47 mho/m $\pm$ 6 %
<b>Body TSL temperature change during test</b>	< 0.5 °C	----	----

## SAR result with Body TSL

<b>SAR averaged over 1 cm<sup>3</sup> (1 g) of Body TSL</b>	Condition	
SAR measured	250 mW input power	9.15 W/kg
SAR for nominal Body TSL parameters	normalized to 1W	<b>37.0 W/kg <math>\pm</math> 17.0 % (k=2)</b>

<b>SAR averaged over 10 cm<sup>3</sup> (10 g) of Body TSL</b>	condition	
SAR measured	250 mW input power	4.93 W/kg
SAR for nominal Body TSL parameters	normalized to 1W	<b>19.8 W/kg <math>\pm</math> 16.5 % (k=2)</b>

## Appendix (Additional assessments outside the scope of SCS 0108)

### Antenna Parameters with Head TSL

Impedance, transformed to feed point	48.9 $\Omega$ - 0.5 j $\Omega$
Return Loss	- 38.5 dB

### Antenna Parameters with Body TSL

Impedance, transformed to feed point	45.2 $\Omega$ - 0.8 j $\Omega$
Return Loss	- 25.9 dB

### General Antenna Parameters and Design

Electrical Delay (one direction)	1.217 ns
----------------------------------	----------

After long term use with 100W radiated power, only a slight warming of the dipole near the feedpoint can be measured.

The dipole is made of standard semirigid coaxial cable. The center conductor of the feeding line is directly connected to the second arm of the dipole. The antenna is therefore short-circuited for DC-signals. On some of the dipoles, small end caps are added to the dipole arms in order to improve matching when loaded according to the position as explained in the "Measurement Conditions" paragraph. The SAR data are not affected by this change. The overall dipole length is still according to the Standard.

No excessive force must be applied to the dipole arms, because they might bend or the soldered connections near the feedpoint may be damaged.

### Additional EUT Data

Manufactured by	SPEAG
Manufactured on	November 07, 2012

## DASY5 Validation Report for Head TSL

Date: 09.05.2017

Test Laboratory: SPEAG, Zurich, Switzerland

**DUT: Dipole 1750 MHz; Type: D1750V2; Serial: D1750V2 - SN:1092**

Communication System: UID 0 - CW; Frequency: 1750 MHz

Medium parameters used:  $f = 1750$  MHz;  $\sigma = 1.36$  S/m;  $\epsilon_r = 39$ ;  $\rho = 1000$  kg/m<sup>3</sup>

Phantom section: Flat Section

Measurement Standard: DASY5 (IEEE/IEC/ANSI C63.19-2011)

DASY52 Configuration:

- Probe: EX3DV4 - SN7349; ConvF(8.46, 8.46, 8.46); Calibrated: 31.12.2016;
- Sensor-Surface: 1.4mm (Mechanical Surface Detection)
- Electronics: DAE4 Sn601; Calibrated: 28.03.2017
- Phantom: Flat Phantom 5.0 (front); Type: QD000P50AA; Serial: 1001
- DASY52 52.10.0(1442); SEMCAD X 14.6.10(7413)

### **Dipole Calibration for Head Tissue/Pin=250 mW, d=10mm/Zoom Scan (7x7x7)/Cube 0:**

Measurement grid: dx=5mm, dy=5mm, dz=5mm

Reference Value = 105.6 V/m; Power Drift = -0.05 dB

Peak SAR (extrapolated) = 16.5 W/kg

**SAR(1 g) = 9.11 W/kg; SAR(10 g) = 4.83 W/kg**

Maximum value of SAR (measured) = 13.8 W/kg

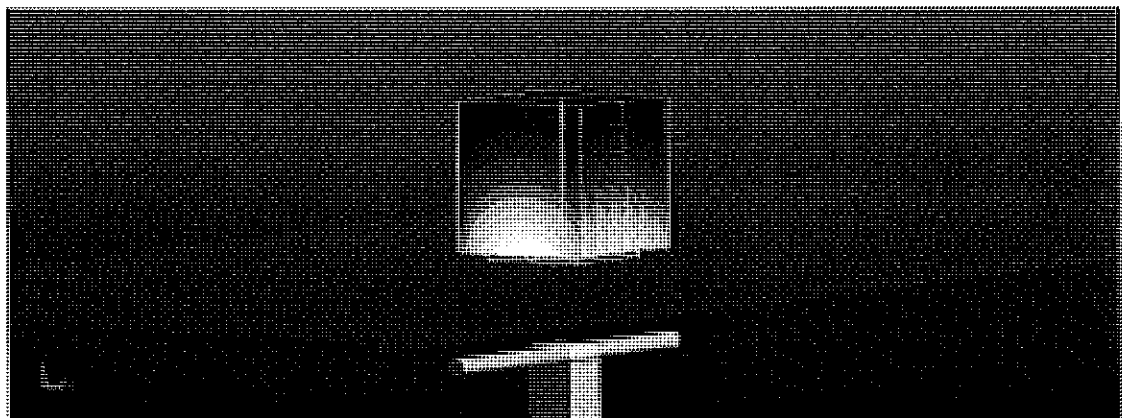
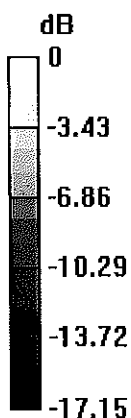

0 dB = 13.8 W/kg = 11.40 dBW/kg

# Impedance Measurement Plot for Head TSL

9 May 2017 14:40:22

CH1 S11 1 U FS 1: 48.926  $\Omega$  -480.47  $m\Omega$  189.29  $\mu F$  1 750.000 000 MHz

\*  
Del

CA

Avg  
16

H1d

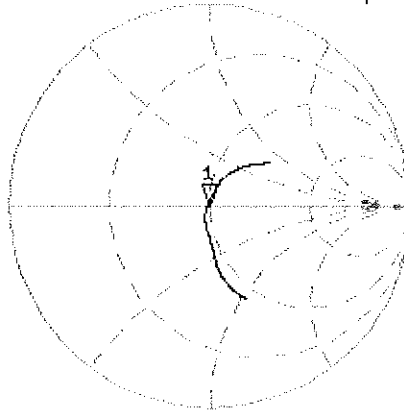

CH2 S11 LOG 5 dB/REF -20 dB 1: -38.467 dB 1 750.000 000 MHz

CA

Avg  
16

H1d

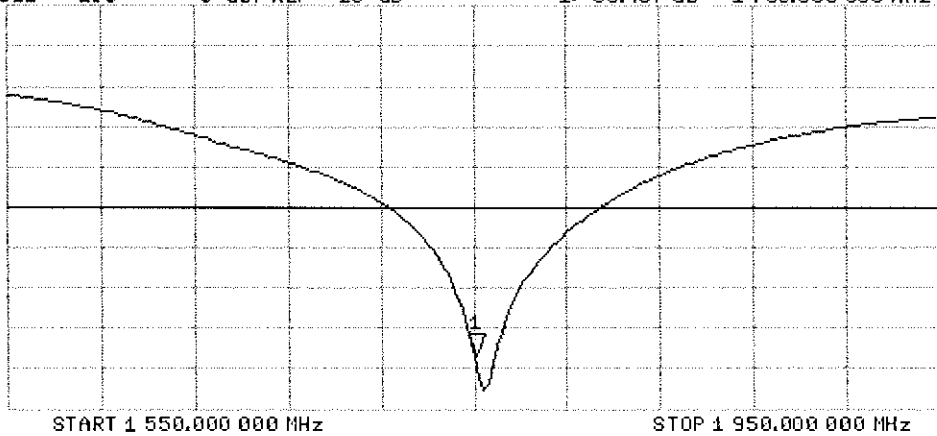



## DASY5 Validation Report for Body TSL

Date: 09.05.2017

Test Laboratory: SPEAG, Zurich, Switzerland

**DUT: Dipole 1750 MHz; Type: D1750V2; Serial: D1750V2 - SN:1092**

Communication System: UID 0 - CW; Frequency: 1750 MHz

Medium parameters used:  $f = 1750$  MHz;  $\sigma = 1.47$  S/m;  $\epsilon_r = 53.7$ ;  $\rho = 1000$  kg/m<sup>3</sup>

Phantom section: Flat Section

Measurement Standard: DASY5 (IEEE/IEC/ANSI C63.19-2011)

DASY52 Configuration:

- Probe: EX3DV4 - SN7349; ConvF(8.25, 8.25, 8.25); Calibrated: 31.12.2016;
- Sensor-Surface: 1.4mm (Mechanical Surface Detection)
- Electronics: DAE4 Sn601; Calibrated: 28.03.2017
- Phantom: Flat Phantom 5.0 (back); Type: QD 000 P50 AA; Serial: 1002
- DASY52 52.10.0(1442); SEMCAD X 14.6.10(7413)

### Dipole Calibration for Body Tissue/Pin=250 mW, d=10mm/Zoom Scan (7x7x7)/Cube 0:

Measurement grid: dx=5mm, dy=5mm, dz=5mm

Reference Value = 98.81 V/m; Power Drift = -0.09 dB

Peak SAR (extrapolated) = 15.8 W/kg

**SAR(1 g) = 9.15 W/kg; SAR(10 g) = 4.93 W/kg**

Maximum value of SAR (measured) = 13.1 W/kg

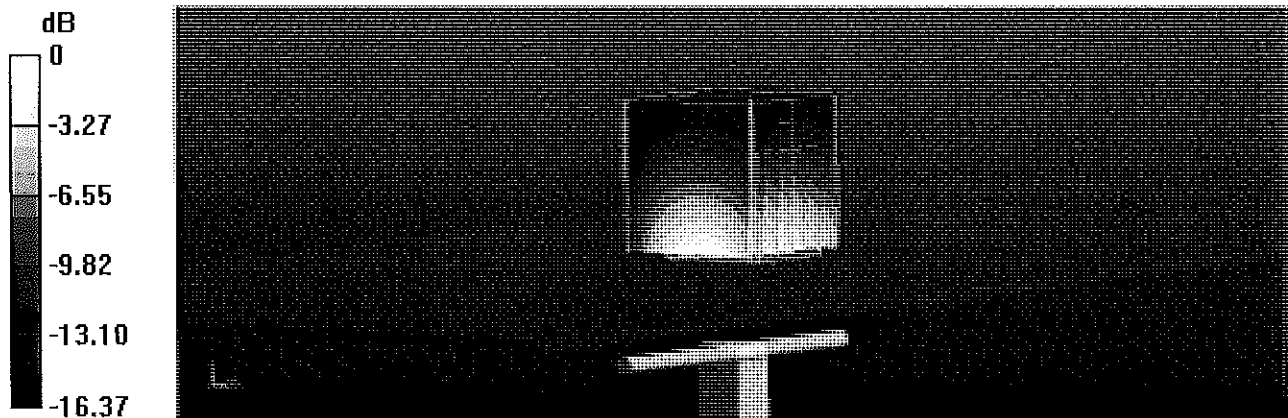

0 dB = 13.1 W/kg = 11.17 dBW/kg

# Impedance Measurement Plot for Body TSL

9 May 2017 14:39:51

CH1 S11 1 U FS 1: 45.234  $\Omega$  -765.63 m $\Omega$  118.79 pF 1 750.000 000 MHz

\*  
Del

CA

Avg  
16

H1 d

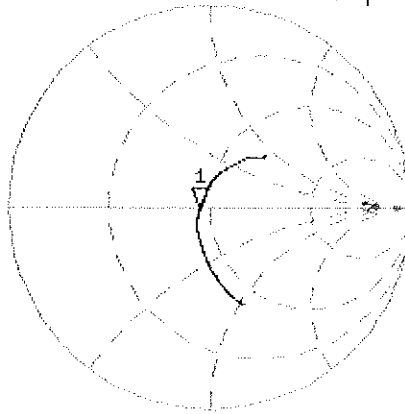

CH2 S11 LOG 5 dB/REF -20 dB 1: -25.909 dB 1 750.000 000 MHz

CA

Avg  
16

H1 d

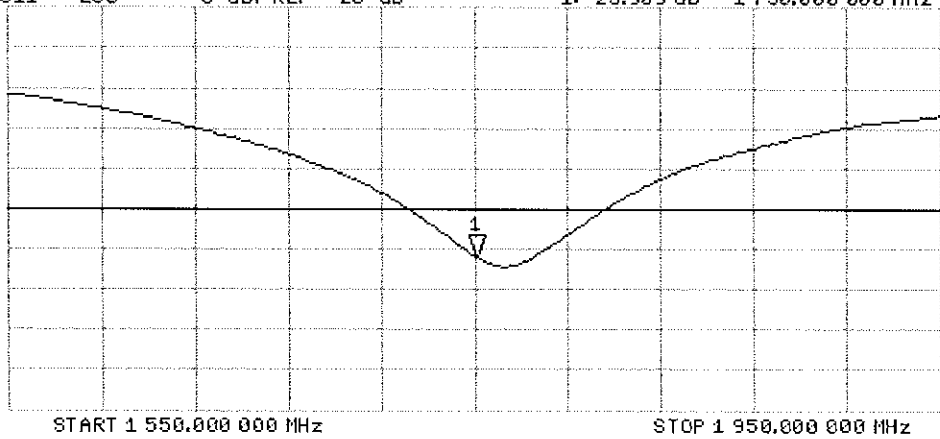



Accredited by the Swiss Accreditation Service (SAS)  
The Swiss Accreditation Service is one of the signatories to the EA  
Multilateral Agreement for the recognition of calibration certificates

Accreditation No.: **SCS 0108**

Client **PC Test**

Certificate No: **D1900V2-5d080\_Jul16**

## CALIBRATION CERTIFICATE

Object **D1900V2 - SN:5d080**

Calibration procedure(s) **QA CAL-05.v9  
Calibration procedure for dipole validation kits above 700 MHz**

Calibration date: **July 08, 2016**

*BNV  
7/16/2016*

This calibration certificate documents the traceability to national standards, which realize the physical units of measurements (SI).  
The measurements and the uncertainties with confidence probability are given on the following pages and are part of the certificate.

All calibrations have been conducted in the closed laboratory facility: environment temperature (22 ± 3)°C and humidity < 70%.

Calibration Equipment used (M&TE critical for calibration)

Primary Standards	ID #	Cal Date (Certificate No.)	Scheduled Calibration
Power meter NRP	SN: 104778	06-Apr-16 (No. 217-02288/02289)	Apr-17
Power sensor NRP-Z91	SN: 103244	06-Apr-16 (No. 217-02288)	Apr-17
Power sensor NRP-Z91	SN: 103245	06-Apr-16 (No. 217-02289)	Apr-17
Reference 20 dB Attenuator	SN: 5058 (20k)	05-Apr-16 (No. 217-02292)	Apr-17
Type-N mismatch combination	SN: 5047.2 / 06327	05-Apr-16 (No. 217-02295)	Apr-17
Reference Probe EX3DV4	SN: 7349	15-Jun-16 (No. EX3-7349_Jun16)	Jun-17
DAE4	SN: 601	30-Dec-15 (No. DAE4-601_Dec15)	Dec-16
Secondary Standards	ID #	Check Date (in house)	Scheduled Check
Power meter EPM-442A	SN: GB37480704	07-Oct-15 (No. 217-02222)	In house check: Oct-16
Power sensor HP 8481A	SN: US37292783	07-Oct-15 (No. 217-02222)	In house check: Oct-16
Power sensor HP 8481A	SN: MY41092317	07-Oct-15 (No. 217-02223)	In house check: Oct-16
RF generator R&S SMT-06	SN: 100972	15-Jun-15 (in house check Jun-15)	In house check: Oct-16
Network Analyzer HP 8753E	SN: US37390585	18-Oct-01 (in house check Oct-15)	In house check: Oct-16

Calibrated by: **Jeton Kastrati**      Name: **Jeton Kastrati**      Function: **Laboratory Technician**

Approved by: **Katja Pokovic**      Name: **Katja Pokovic**      Function: **Technical Manager**

Signature

Issued: July 13, 2016

This calibration certificate shall not be reproduced except in full without written approval of the laboratory.



Accredited by the Swiss Accreditation Service (SAS)  
The Swiss Accreditation Service is one of the signatories to the EA  
Multilateral Agreement for the recognition of calibration certificates

Accreditation No.: **SCS 0108**

**Glossary:**

TSL	tissue simulating liquid
ConvF	sensitivity in TSL / NORM x,y,z
N/A	not applicable or not measured

**Calibration is Performed According to the Following Standards:**

- a) IEEE Std 1528-2013, "IEEE Recommended Practice for Determining the Peak Spatial-Averaged Specific Absorption Rate (SAR) in the Human Head from Wireless Communications Devices: Measurement Techniques", June 2013
- b) IEC 62209-1, "Procedure to measure the Specific Absorption Rate (SAR) for hand-held devices used in close proximity to the ear (frequency range of 300 MHz to 3 GHz)", February 2005
- c) IEC 62209-2, "Procedure to determine the Specific Absorption Rate (SAR) for wireless communication devices used in close proximity to the human body (frequency range of 30 MHz to 6 GHz)", March 2010
- d) KDB 865664, "SAR Measurement Requirements for 100 MHz to 6 GHz"

**Additional Documentation:**

- e) DASY4/5 System Handbook

**Methods Applied and Interpretation of Parameters:**

- *Measurement Conditions:* Further details are available from the Validation Report at the end of the certificate. All figures stated in the certificate are valid at the frequency indicated.
- *Antenna Parameters with TSL:* The dipole is mounted with the spacer to position its feed point exactly below the center marking of the flat phantom section, with the arms oriented parallel to the body axis.
- *Feed Point Impedance and Return Loss:* These parameters are measured with the dipole positioned under the liquid filled phantom. The impedance stated is transformed from the measurement at the SMA connector to the feed point. The Return Loss ensures low reflected power. No uncertainty required.
- *Electrical Delay:* One-way delay between the SMA connector and the antenna feed point. No uncertainty required.
- *SAR measured:* SAR measured at the stated antenna input power.
- *SAR normalized:* SAR as measured, normalized to an input power of 1 W at the antenna connector.
- *SAR for nominal TSL parameters:* The measured TSL parameters are used to calculate the nominal SAR result.

The reported uncertainty of measurement is stated as the standard uncertainty of measurement multiplied by the coverage factor  $k=2$ , which for a normal distribution corresponds to a coverage probability of approximately 95%.

## Measurement Conditions

DASY system configuration, as far as not given on page 1.

DASY Version	DASY5	V52.8.8
Extrapolation	Advanced Extrapolation	
Phantom	Modular Flat Phantom	
Distance Dipole Center - TSL	10 mm	with Spacer
Zoom Scan Resolution	dx, dy, dz = 5 mm	
Frequency	1900 MHz $\pm$ 1 MHz	

## Head TSL parameters

The following parameters and calculations were applied.

	Temperature	Permittivity	Conductivity
Nominal Head TSL parameters	22.0 °C	40.0	1.40 mho/m
Measured Head TSL parameters	(22.0 $\pm$ 0.2) °C	39.8 $\pm$ 6 %	1.38 mho/m $\pm$ 6 %
Head TSL temperature change during test	< 0.5 °C	----	----

## SAR result with Head TSL

SAR averaged over 1 cm <sup>3</sup> (1 g) of Head TSL	Condition	
SAR measured	250 mW input power	9.76 W/kg
SAR for nominal Head TSL parameters	normalized to 1W	39.3 W/kg $\pm$ 17.0 % (k=2)

SAR averaged over 10 cm <sup>3</sup> (10 g) of Head TSL	condition	
SAR measured	250 mW input power	5.10 W/kg
SAR for nominal Head TSL parameters	normalized to 1W	20.5 W/kg $\pm$ 16.5 % (k=2)

## Body TSL parameters

The following parameters and calculations were applied.

	Temperature	Permittivity	Conductivity
Nominal Body TSL parameters	22.0 °C	53.3	1.52 mho/m
Measured Body TSL parameters	(22.0 $\pm$ 0.2) °C	52.7 $\pm$ 6 %	1.51 mho/m $\pm$ 6 %
Body TSL temperature change during test	< 0.5 °C	----	----

## SAR result with Body TSL

SAR averaged over 1 cm <sup>3</sup> (1 g) of Body TSL	Condition	
SAR measured	250 mW input power	9.75 W/kg
SAR for nominal Body TSL parameters	normalized to 1W	39.1 W/kg $\pm$ 17.0 % (k=2)

SAR averaged over 10 cm <sup>3</sup> (10 g) of Body TSL	condition	
SAR measured	250 mW input power	5.17 W/kg
SAR for nominal Body TSL parameters	normalized to 1W	20.7 W/kg $\pm$ 16.5 % (k=2)

## Appendix (Additional assessments outside the scope of SCS 0108)

### Antenna Parameters with Head TSL

Impedance, transformed to feed point	52.1 $\Omega$ + 5.3 j $\Omega$
Return Loss	- 25.1 dB

### Antenna Parameters with Body TSL

Impedance, transformed to feed point	47.4 $\Omega$ + 6.8 j $\Omega$
Return Loss	- 22.6 dB

### General Antenna Parameters and Design

Electrical Delay (one direction)	1.192 ns
----------------------------------	----------

After long term use with 100W radiated power, only a slight warming of the dipole near the feedpoint can be measured.

The dipole is made of standard semirigid coaxial cable. The center conductor of the feeding line is directly connected to the second arm of the dipole. The antenna is therefore short-circuited for DC-signals. On some of the dipoles, small end caps are added to the dipole arms in order to improve matching when loaded according to the position as explained in the "Measurement Conditions" paragraph. The SAR data are not affected by this change. The overall dipole length is still according to the Standard.

No excessive force must be applied to the dipole arms, because they might bend or the soldered connections near the feedpoint may be damaged.

### Additional EUT Data

Manufactured by	SPEAG
Manufactured on	June 28, 2006

## DASY5 Validation Report for Head TSL

Date: 08.07.2016

Test Laboratory: SPEAG, Zurich, Switzerland

**DUT: Dipole 1900 MHz; Type: D1900V2; Serial: D1900V2 - SN:5d080**

Communication System: UID 0 - CW; Frequency: 1900 MHz

Medium parameters used:  $f = 1900$  MHz;  $\sigma = 1.38$  S/m;  $\epsilon_r = 39.8$ ;  $\rho = 1000$  kg/m<sup>3</sup>

Phantom section: Flat Section

Measurement Standard: DASY5 (IEEE/IEC/ANSI C63.19-2011)

DASY52 Configuration:

- Probe: EX3DV4 - SN7349; ConvF(7.99, 7.99, 7.99); Calibrated: 15.06.2016;
- Sensor-Surface: 1.4mm (Mechanical Surface Detection)
- Electronics: DAE4 Sn601; Calibrated: 30.12.2015
- Phantom: Flat Phantom 5.0 (front); Type: QD000P50AA; Serial: 1001
- DASY52 52.8.8(1258); SEMCAD X 14.6.10(7372)

### Dipole Calibration for Head Tissue/Pin=250 mW, d=10mm/Zoom Scan (7x7x7)/Cube 0:

Measurement grid: dx=5mm, dy=5mm, dz=5mm

Reference Value = 106.6 V/m; Power Drift = -0.04 dB

Peak SAR (extrapolated) = 18.4 W/kg

**SAR(1 g) = 9.76 W/kg; SAR(10 g) = 5.1 W/kg**

Maximum value of SAR (measured) = 15.0 W/kg

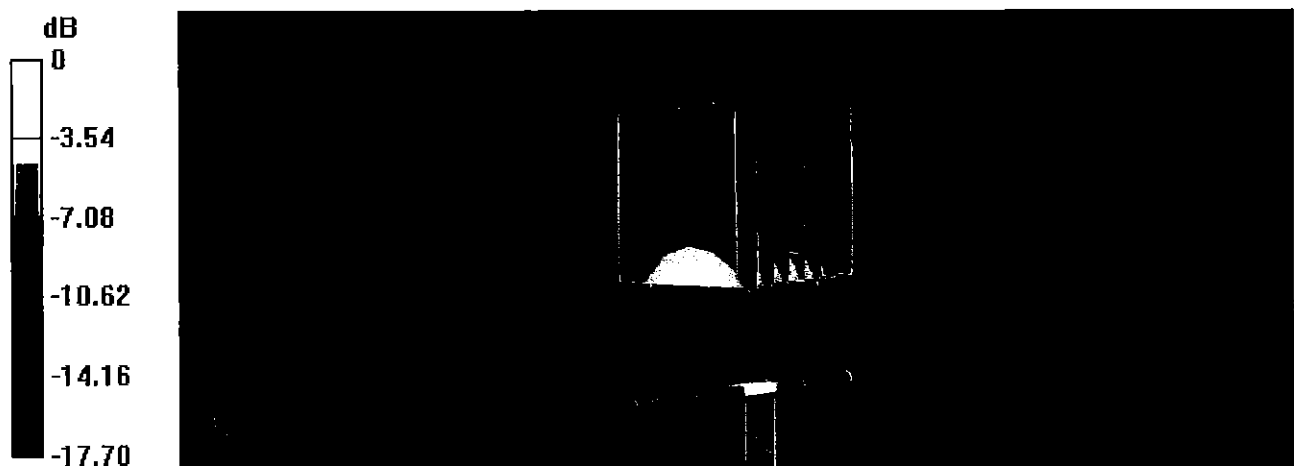

0 dB = 15.0 W/kg = 11.76 dBW/kg

# Impedance Measurement Plot for Head TSL

8 Jul 2016 16:18:04

CH1 S11 1 U FS 1: 52.143  $\Omega$  5.2500  $\Omega$  439.78 pF 1 900.000 000 MHz

\*  
Del  
Cor

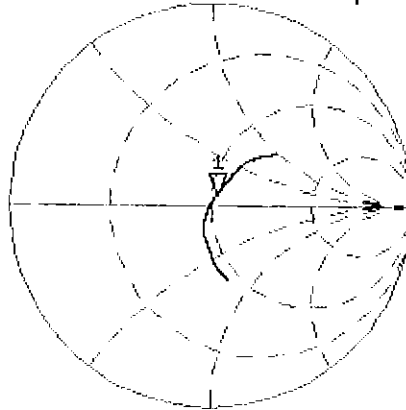

Avg  
16

H1d

CH2 S11 LOG 5 dB/REF -20 dB 1:-25.118 dB 1 900.000 000 MHz

Cor

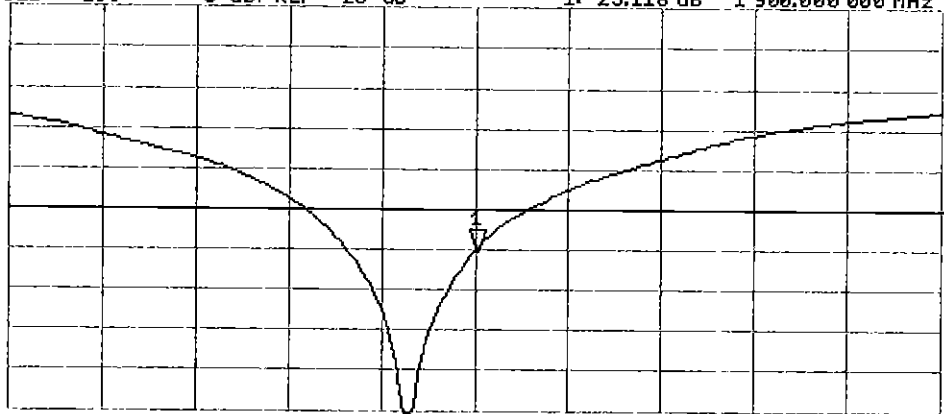

Avg  
16

H1d

START 1 700.000 000 MHz

STOP 2 1 000.000 000 MHz



# DASY5 Validation Report for Body TSL

Date: 08.07.2016

Test Laboratory: SPEAG, Zurich, Switzerland

**DUT: Dipole 1900 MHz; Type: D1900V2; Serial: D1900V2 - SN:5d080**

Communication System: UID 0 - CW; Frequency: 1900 MHz

Medium parameters used:  $f = 1900$  MHz;  $\sigma = 1.51$  S/m;  $\epsilon_r = 52.7$ ;  $\rho = 1000$  kg/m<sup>3</sup>

Phantom section: Flat Section

Measurement Standard: DASY5 (IEEE/IEC/ANSI C63.19-2011)

DASY52 Configuration:

- Probe: EX3DV4 - SN7349; ConvF(8.03, 8.03, 8.03); Calibrated: 15.06.2016;
- Sensor-Surface: 1.4mm (Mechanical Surface Detection)
- Electronics: DAE4 Sn601; Calibrated: 30.12.2015
- Phantom: Flat Phantom 5.0 (back); Type: QD000P50AA; Serial: 1002
- DASY52 52.8.8(1258); SEMCAD X 14.6.10(7372)

## Dipole Calibration for Body Tissue/Pin=250 mW, d=10mm/Zoom Scan (7x7x7)/Cube 0:

Measurement grid: dx=5mm, dy=5mm, dz=5mm

Reference Value = 103.1 V/m; Power Drift = -0.02 dB

Peak SAR (extrapolated) = 17.1 W/kg

**SAR(1 g) = 9.75 W/kg; SAR(10 g) = 5.17 W/kg**

Maximum value of SAR (measured) = 14.7 W/kg

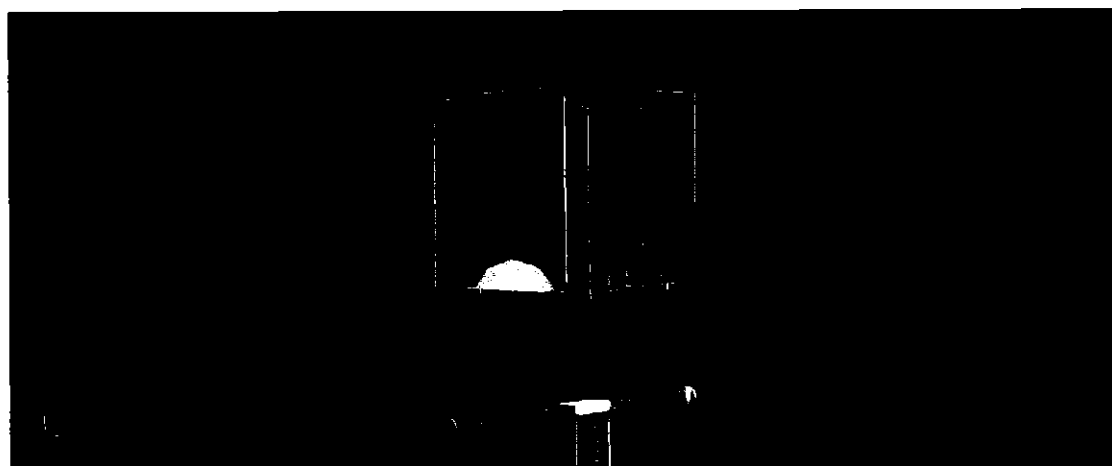
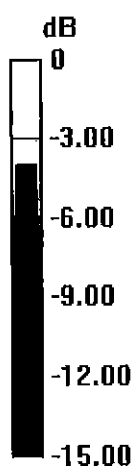

0 dB = 14.7 W/kg = 11.67 dBW/kg

# Impedance Measurement Plot for Body TSL

8 Jul 2016 16:16:56

CH1 S11 1 U FS

1: 47.412  $\Omega$  6.7422  $\Omega$  564.78  $\mu\text{H}$

1 900.000 000 MHz

\*  
De1  
Cor

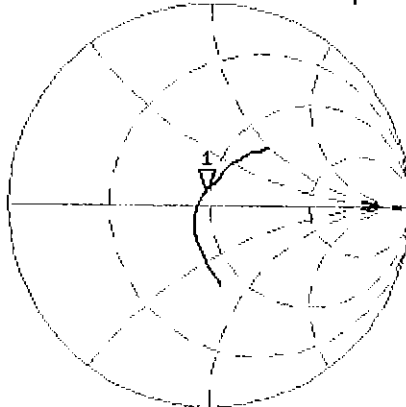

Avg  
16

H1d

CH2 S11 LOG

5 dB/REF -20 dB

1:-22.620 dB

1 900.000 000 MHz

Cor

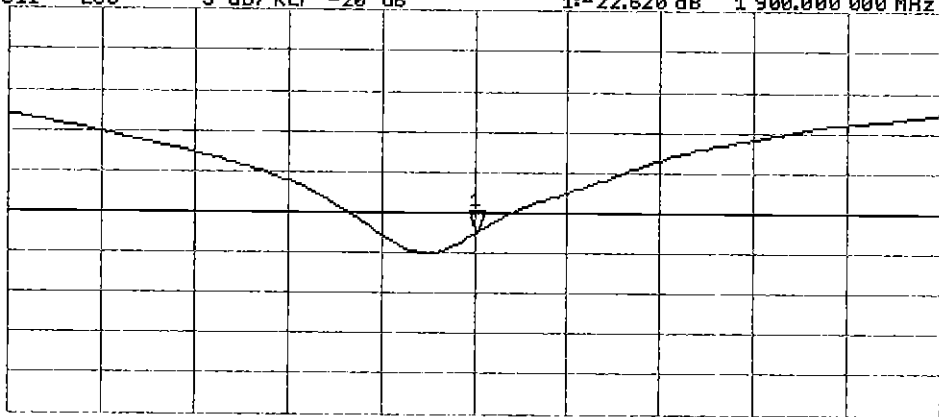

Avg  
16

H1d

START 1 700.000 000 MHz

STOP 2 1 000.000 000 MHz

## Certification of Calibration

Object D1900V2 – SN: 5d080

Calibration procedure(s) Procedure for Calibration Extension for SAR Dipoles.

Calibration date: July 06, 2017

Description: SAR Validation Dipole at 1900 MHz.

**Calibration Equipment used:**

Manufacturer	Model	Description	Cal Date	Cal Interval	Cal Due	Serial Number
Agilent	8753ES	S-Parameter Vector Network Analyzer	8/19/2016	Annual	8/19/2017	MY40003841
Agilent	N5182A	MXG Vector Signal Generator	2/28/2017	Annual	2/28/2018	MY47420800
Amplifier Research	15S1G6	Amplifier	CBT	N/A	CBT	433971
Anritsu	ML2495A	Power Meter	10/16/2015	Biennial	10/16/2017	941001
Anritsu	MA24106A	USB Power Sensor	6/7/2017	Annual	6/7/2018	1231535
Anritsu	MA24106A	USB Power Sensor	6/7/2017	Annual	6/7/2018	1231538
Keysight Technologies	85033E	Standard Mechanical Calibration Kit (DC to 9GHz, 3.5mm)	6/1/2017	Annual	6/1/2018	MY53401181
MiniCircuits	SLP-2400+	Low Pass Filter	CBT	N/A	CBT	R8979500903
Mini-Circuits	BW-N20W5+	DC to 18 GHz Precision Fixed 20 dB Attenuator	CBT	N/A	CBT	N/A
Narda	4772-3	Attenuator (3dB)	CBT	N/A	CBT	9406
Pasternack	PE2209-10	Bidirectional Coupler	CBT	N/A	CBT	N/A
Pasternack	NC-100	Torque Wrench	3/8/2017	Annual	3/8/2018	N/A
SPEAG	DAE4	Dasy Data Acquisition Electronics	3/13/2017	Annual	3/13/2018	1415
SPEAG	ES3DV3	SAR Probe	3/14/2017	Annual	3/14/2018	3209

	Name	Function	Signature
Calibrated By:	Brodie Halfoster	Test Engineer	<i>BRODIE HALFOSTER</i>
Approved By:	Kaitlin O'Keefe	Senior Technical Manager	<i>KOK</i>

# DIPOLE CALIBRATION EXTENSION

Per KDB 865664 D01, calibration intervals of up to three years may be considered for reference dipoles when it is demonstrated that the SAR target, impedance and return loss of a dipole have remained stable according to the following requirements:

1. The measured SAR does not deviate more than 10% from the target on the calibration certificate.
2. The return-loss does not deviate more than 20% from the previous measurement and meets the required 20dB minimum return-loss requirement.
3. The measurement of real or imaginary parts of impedance does not deviate more than 5Ω from the previous measurement.

The following dipole was checked to pass the above 3 requirements to have 2-year calibration period from the calibration date:

Dipole	Calibration Date	Extension Date	Certificate Electrical Delay (ns)	Certificate SAR Target Head (1g) W/kg @ 20.0 dBm	Measured Head SAR (1g) W/kg @ 20.0 dBm	Deviation (%)	Certificate SAR Target Head (10g) W/kg @ 20.0 dBm	Measured Head SAR (10g) W/kg @ 20.0 dBm	Deviation 10g (%)	Certificate Impedance Head (Ohm)	Measured Impedance Head (Ohm)	Difference (Ohm)	Certificate Impedance Head (Ohm) Imaginary	Measured Impedance Head (Ohm) Imaginary	Difference (Ohm) Imaginary	Certificate Return Loss Head (dB)	Measured Return Loss Head (dB)	Deviation (%)	PASS/FAIL
5d080	7/6/2016	7/6/2017	1.192	3.93	3.86	-1.80%	2.05	2	-2.40%	52.1	52.85	0.75	5.3	4.6816	0.618	-25.1	-25.595	-2.00%	PASS

Dipole	Calibration Date	Extension Date	Certificate Electrical Delay (ns)	Certificate SAR Target Body (1g) W/kg @ 20.0 dBm	Measured Body SAR (1g) W/kg @ 20.0 dBm	Deviation 1g (%)	Certificate SAR Target Body (10g) W/kg @ 20.0 dBm	Measured Body SAR (10g) W/kg @ 20.0 dBm	Deviation 10g (%)	Certificate Impedance Body (Ohm) Real	Measured Impedance Body (Ohm) Real	Difference (Ohm) Real	Certificate Impedance Body (Ohm) Imaginary	Measured Impedance Body (Ohm) Imaginary	Difference (Ohm) Imaginary	Certificate Return Loss Body (dB)	Measured Return Loss Body (dB)	Deviation (%)	PASS/FAIL
5d080	7/6/2016	7/6/2017	1.192	3.91	4.05	3.60%	2.07	2.11	1.90%	47.4	48.03	0.63	6.8	5.0996	1.7	-22.6	-25.469	-12.70%	PASS

# Impedance & Return-Loss Measurement Plot for Head TSL taken on July 6, 2017 for Calibration Extension

6 Jul 2017 22:52:01  
[CH1] S11 1 U FS 1: 52.850  $\Omega$  4.6816  $\Omega$  392.16  $\mu\text{H}$  1 900.000 000 MHz

\*  
Del  
Cor  
Avg  
16  
↑

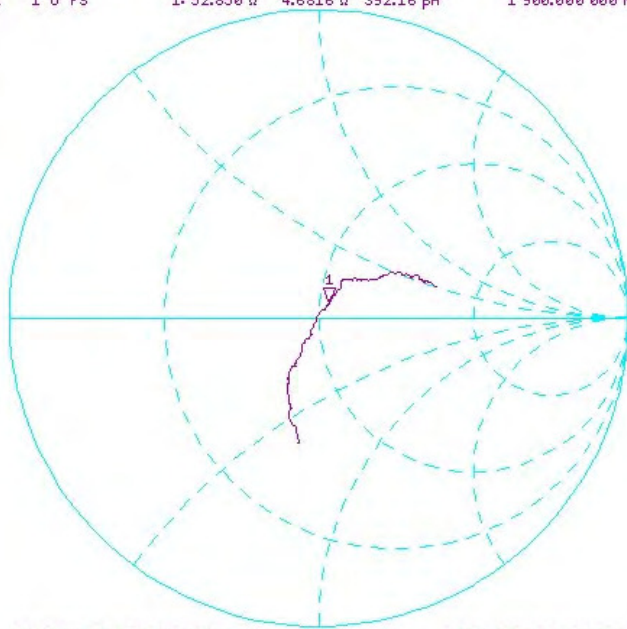

CENTER 1 900.000 000 MHz SPAN 400.000 000 MHz

6 Jul 2017 22:51:01  
[CH1] S11 LOG 5 dB/REF -20 dB 1:-25.595 dB 1 900.000 000 MHz

\*  
Del  
Cor  
Avg  
16  
↑

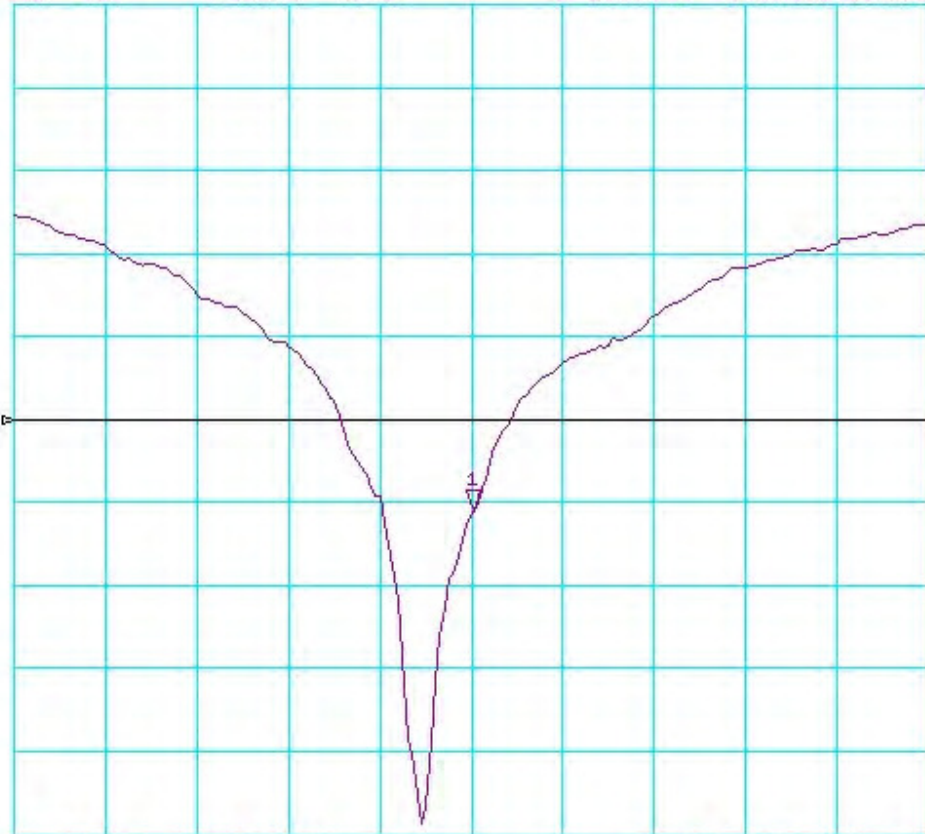

CENTER 1 900.000 000 MHz SPAN 400.000 000 MHz

# Impedance & Return-Loss Measurement Plot for Body TSL taken on July 6, 2017 for Calibration Extension

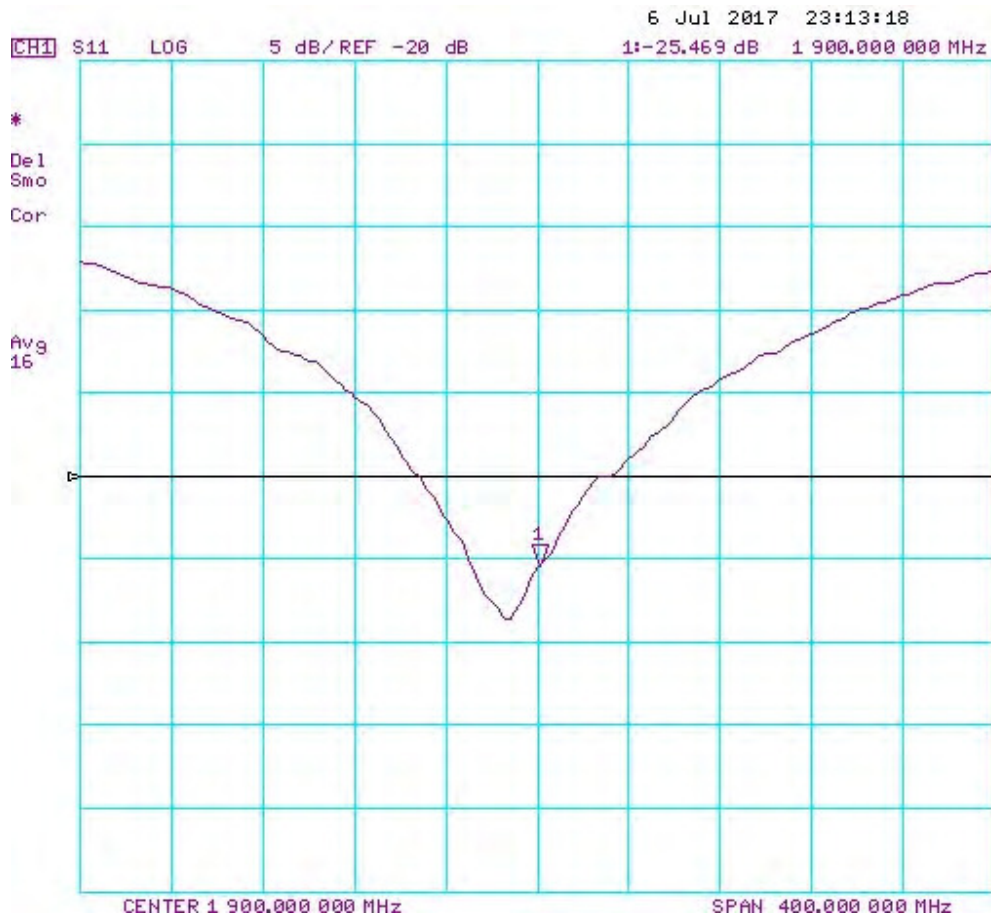
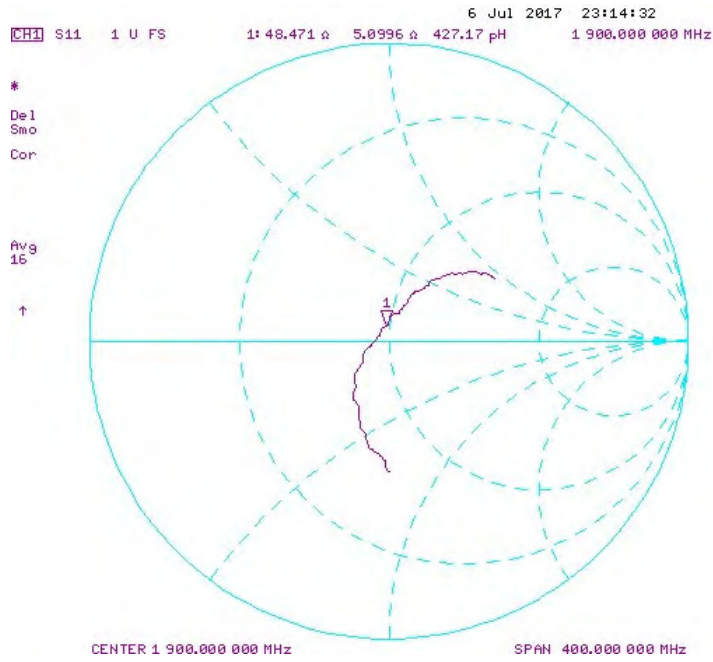



Accredited by the Swiss Accreditation Service (SAS)  
The Swiss Accreditation Service is one of the signatories to the EA  
Multilateral Agreement for the recognition of calibration certificates

Accreditation No.: **SCS 0108**

Client **PC Test**

Certificate No: **D1900V2-5d026\_May17**

## CALIBRATION CERTIFICATE

Object **D1900V2 - SN:5d026**

Calibration procedure(s) **QA CAL-05.v9**  
**Calibration procedure for dipole validation kits above 700 MHz**

Calibration date: **May 10, 2017**

*BNV*  
*05-23-2017*

This calibration certificate documents the traceability to national standards, which realize the physical units of measurements (SI).  
The measurements and the uncertainties with confidence probability are given on the following pages and are part of the certificate.

All calibrations have been conducted in the closed laboratory facility: environment temperature ( $22 \pm 3$ )°C and humidity < 70%.

Calibration Equipment used (M&TE critical for calibration)

Primary Standards	ID #	Cal Date (Certificate No.)	Scheduled Calibration
Power meter NRP	SN: 104778	04-Apr-17 (No. 217-02521/02522)	Apr-18
Power sensor NRP-Z91	SN: 103244	04-Apr-17 (No. 217-02521)	Apr-18
Power sensor NRP-Z91	SN: 103245	04-Apr-17 (No. 217-02522)	Apr-18
Reference 20 dB Attenuator	SN: 5058 (20k)	07-Apr-17 (No. 217-02528)	Apr-18
Type-N mismatch combination	SN: 5047.2 / 06327	07-Apr-17 (No. 217-02529)	Apr-18
Reference Probe EX3DV4	SN: 7349	31-Dec-16 (No. EX3-7349_Dec16)	Dec-17
DAE4	SN: 601	28-Mar-17 (No. DAE4-601_Mar17)	Mar-18
Secondary Standards	ID #	Check Date (in house)	Scheduled Check
Power meter EPM-442A	SN: GB37480704	07-Oct-15 (in house check Oct-16)	In house check: Oct-18
Power sensor HP 8481A	SN: US37292783	07-Oct-15 (in house check Oct-16)	In house check: Oct-18
Power sensor HP 8481A	SN: MY41092317	07-Oct-15 (in house check Oct-16)	In house check: Oct-18
RF generator R&S SMT-06	SN: 100972	15-Jun-15 (in house check Oct-16)	In house check: Oct-18
Network Analyzer HP 8753E	SN: US37390585	18-Oct-01 (in house check Oct-16)	In house check: Oct-17

Calibrated by: **Leif Klysner**      Name: **Leif Klysner**      Function: **Laboratory Technician**

Approved by: **Katja Pokovic**      Name: **Katja Pokovic**      Function: **Technical Manager**

Signature

*Leif Klysner*  
*Katja Pokovic*

Issued: May 12, 2017

This calibration certificate shall not be reproduced except in full without written approval of the laboratory.



Accredited by the Swiss Accreditation Service (SAS)

The Swiss Accreditation Service is one of the signatories to the EA Multilateral Agreement for the recognition of calibration certificates

Accreditation No.: **SCS 0108**

### Glossary:

TSL	tissue simulating liquid
ConvF	sensitivity in TSL / NORM x,y,z
N/A	not applicable or not measured

### Calibration is Performed According to the Following Standards:

- IEEE Std 1528-2013, "IEEE Recommended Practice for Determining the Peak Spatial-Averaged Specific Absorption Rate (SAR) in the Human Head from Wireless Communications Devices: Measurement Techniques", June 2013
- IEC 62209-1, "Procedure to measure the Specific Absorption Rate (SAR) for hand-held devices used in close proximity to the ear (frequency range of 300 MHz to 3 GHz)", February 2005
- IEC 62209-2, "Procedure to determine the Specific Absorption Rate (SAR) for wireless communication devices used in close proximity to the human body (frequency range of 30 MHz to 6 GHz)", March 2010
- KDB 865664, "SAR Measurement Requirements for 100 MHz to 6 GHz"

### Additional Documentation:

- DASY4/5 System Handbook

### Methods Applied and Interpretation of Parameters:

- Measurement Conditions:** Further details are available from the Validation Report at the end of the certificate. All figures stated in the certificate are valid at the frequency indicated.
- Antenna Parameters with TSL:** The dipole is mounted with the spacer to position its feed point exactly below the center marking of the flat phantom section, with the arms oriented parallel to the body axis.
- Feed Point Impedance and Return Loss:** These parameters are measured with the dipole positioned under the liquid filled phantom. The impedance stated is transformed from the measurement at the SMA connector to the feed point. The Return Loss ensures low reflected power. No uncertainty required.
- Electrical Delay:** One-way delay between the SMA connector and the antenna feed point. No uncertainty required.
- SAR measured:** SAR measured at the stated antenna input power.
- SAR normalized:** SAR as measured, normalized to an input power of 1 W at the antenna connector.
- SAR for nominal TSL parameters:** The measured TSL parameters are used to calculate the nominal SAR result.

The reported uncertainty of measurement is stated as the standard uncertainty of measurement multiplied by the coverage factor  $k=2$ , which for a normal distribution corresponds to a coverage probability of approximately 95%.



## Measurement Conditions

DASY system configuration, as far as not given on page 1.

DASY Version	DASY5	V52.10.0
Extrapolation	Advanced Extrapolation	
Phantom	Modular Flat Phantom	
Distance Dipole Center - TSL	10 mm	with Spacer
Zoom Scan Resolution	dx, dy, dz = 5 mm	
Frequency	1900 MHz $\pm$ 1 MHz	

## Head TSL parameters

The following parameters and calculations were applied.

	Temperature	Permittivity	Conductivity
Nominal Head TSL parameters	22.0 °C	40.0	1.40 mho/m
Measured Head TSL parameters	(22.0 $\pm$ 0.2) °C	41.3 $\pm$ 6 %	1.40 mho/m $\pm$ 6 %
Head TSL temperature change during test	< 0.5 °C	----	----

## SAR result with Head TSL

SAR averaged over 1 cm <sup>3</sup> (1 g) of Head TSL	Condition	
SAR measured	250 mW input power	9.75 W/kg
SAR for nominal Head TSL parameters	normalized to 1W	<b>39.3 W/kg <math>\pm</math> 17.0 % (k=2)</b>

SAR averaged over 10 cm <sup>3</sup> (10 g) of Head TSL	condition	
SAR measured	250 mW input power	5.14 W/kg
SAR for nominal Head TSL parameters	normalized to 1W	<b>20.7 W/kg <math>\pm</math> 16.5 % (k=2)</b>

## Body TSL parameters

The following parameters and calculations were applied.

	Temperature	Permittivity	Conductivity
Nominal Body TSL parameters	22.0 °C	53.3	1.52 mho/m
Measured Body TSL parameters	(22.0 $\pm$ 0.2) °C	54.2 $\pm$ 6 %	1.51 mho/m $\pm$ 6 %
Body TSL temperature change during test	< 0.5 °C	----	----

## SAR result with Body TSL

SAR averaged over 1 cm <sup>3</sup> (1 g) of Body TSL	Condition	
SAR measured	250 mW input power	10.0 W/kg
SAR for nominal Body TSL parameters	normalized to 1W	<b>40.3 W/kg <math>\pm</math> 17.0 % (k=2)</b>

SAR averaged over 10 cm <sup>3</sup> (10 g) of Body TSL	condition	
SAR measured	250 mW input power	5.34 W/kg
SAR for nominal Body TSL parameters	normalized to 1W	<b>21.5 W/kg <math>\pm</math> 16.5 % (k=2)</b>

## Appendix (Additional assessments outside the scope of SCS 0108)

### Antenna Parameters with Head TSL

Impedance, transformed to feed point	52.7 $\Omega$ + 8.4 j $\Omega$
Return Loss	- 21.3 dB

### Antenna Parameters with Body TSL

Impedance, transformed to feed point	47.3 $\Omega$ + 8.8 j $\Omega$
Return Loss	- 20.5 dB

### General Antenna Parameters and Design

Electrical Delay (one direction)	1.199 ns
----------------------------------	----------

After long term use with 100W radiated power, only a slight warming of the dipole near the feedpoint can be measured.

The dipole is made of standard semirigid coaxial cable. The center conductor of the feeding line is directly connected to the second arm of the dipole. The antenna is therefore short-circuited for DC-signals. On some of the dipoles, small end caps are added to the dipole arms in order to improve matching when loaded according to the position as explained in the "Measurement Conditions" paragraph. The SAR data are not affected by this change. The overall dipole length is still according to the Standard.

No excessive force must be applied to the dipole arms, because they might bend or the soldered connections near the feedpoint may be damaged.

### Additional EUT Data

Manufactured by	SPEAG
Manufactured on	December 17, 2002

# DASY5 Validation Report for Head TSL

Date: 10.05.2017

Test Laboratory: SPEAG, Zurich, Switzerland

**DUT: Dipole 1900 MHz; Type: D1900V2; Serial: D1900V2 - SN:5d026**

Communication System: UID 0 - CW; Frequency: 1900 MHz

Medium parameters used:  $f = 1900$  MHz;  $\sigma = 1.4$  S/m;  $\epsilon_r = 41.3$ ;  $\rho = 1000$  kg/m<sup>3</sup>

Phantom section: Flat Section

Measurement Standard: DASY5 (IEEE/IEC/ANSI C63.19-2011)

DASY52 Configuration:

- Probe: EX3DV4 - SN7349; ConvF(8.12, 8.12, 8.12); Calibrated: 31.12.2016;
- Sensor-Surface: 1.4mm (Mechanical Surface Detection)
- Electronics: DAE4 Sn601; Calibrated: 28.03.2017
- Phantom: Flat Phantom 5.0 (front); Type: QD000P50AA; Serial: 1001
- DASY52 52.10.0(1444); SEMCAD X 14.6.10(7416)

## Dipole Calibration for Head Tissue/Pin=250 mW, d=10mm/Zoom Scan (7x7x7)/Cube 0:

Measurement grid: dx=5mm, dy=5mm, dz=5mm

Reference Value = 107.4 V/m; Power Drift = -0.04 dB

Peak SAR (extrapolated) = 17.9 W/kg

**SAR(1 g) = 9.75 W/kg; SAR(10 g) = 5.14 W/kg**

Maximum value of SAR (measured) = 14.9 W/kg

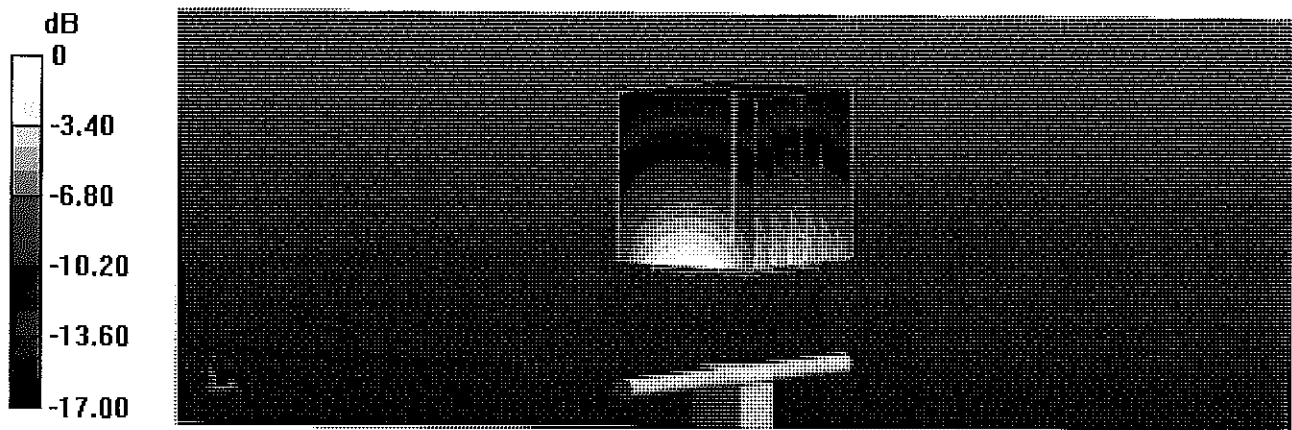

0 dB = 14.9 W/kg = 11.73 dBW/kg

# Impedance Measurement Plot for Head TSL

10 May 2017 10:16:29  
[CH1] S11 1 U FS 1: 52.662  $\Omega$  8.4414  $\Omega$  707.10 pF 1 900.000 000 MHz

\*  
De1  
CA

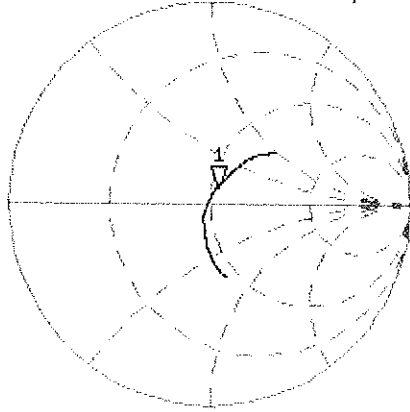

Avg  
16

H1d

CH2 S11 LOG 5 dB/REF -20 dB 1:-21.315 dB 1 900.000 000 MHz

CA

Avg  
16

H1d

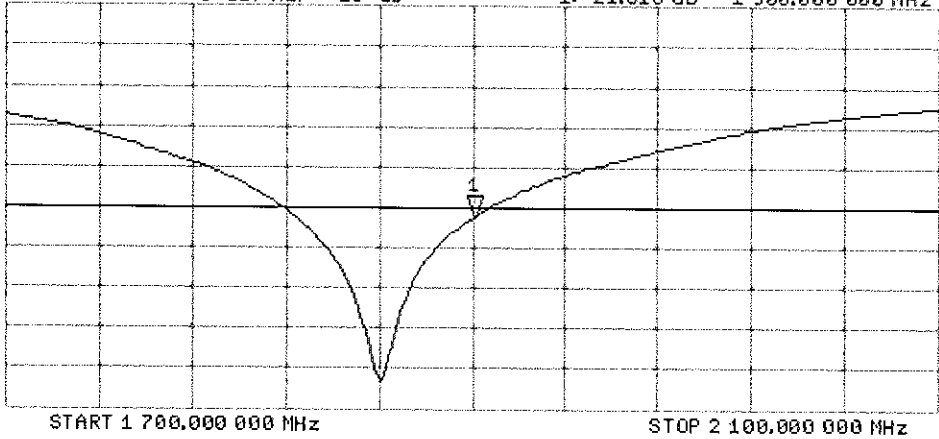

# DASY5 Validation Report for Body TSL

Date: 10.05.2017

Test Laboratory: SPEAG, Zurich, Switzerland

**DUT: Dipole 1900 MHz; Type: D1900V2; Serial: D1900V2 - SN:5d026**

Communication System: UID 0 - CW; Frequency: 1900 MHz

Medium parameters used:  $f = 1900$  MHz;  $\sigma = 1.51$  S/m;  $\epsilon_r = 54.2$ ;  $\rho = 1000$  kg/m<sup>3</sup>

Phantom section: Flat Section

Measurement Standard: DASY5 (IEEE/IEC/ANSI C63.19-2011)

DASY52 Configuration:

- Probe: EX3DV4 - SN7349; ConvF(8.03, 8.03, 8.03); Calibrated: 31.12.2016;
- Sensor-Surface: 1.4mm (Mechanical Surface Detection)
- Electronics: DAE4 Sn601; Calibrated: 28.03.2017
- Phantom: Flat Phantom 5.0 (back); Type: QD 000 P50 AA; Serial: 1002
- DASY52 52.10.0(1444); SEMCAD X 14.6.10(7416)

## Dipole Calibration for Body Tissue/Pin=250 mW, d=10mm/Zoom Scan (7x7x7)/Cube 0:

Measurement grid: dx=5mm, dy=5mm, dz=5mm

Reference Value = 102.9 V/m; Power Drift = -0.06 dB

Peak SAR (extrapolated) = 17.7 W/kg

**SAR(1 g) = 10 W/kg; SAR(10 g) = 5.34 W/kg**

Maximum value of SAR (measured) = 14.5 W/kg

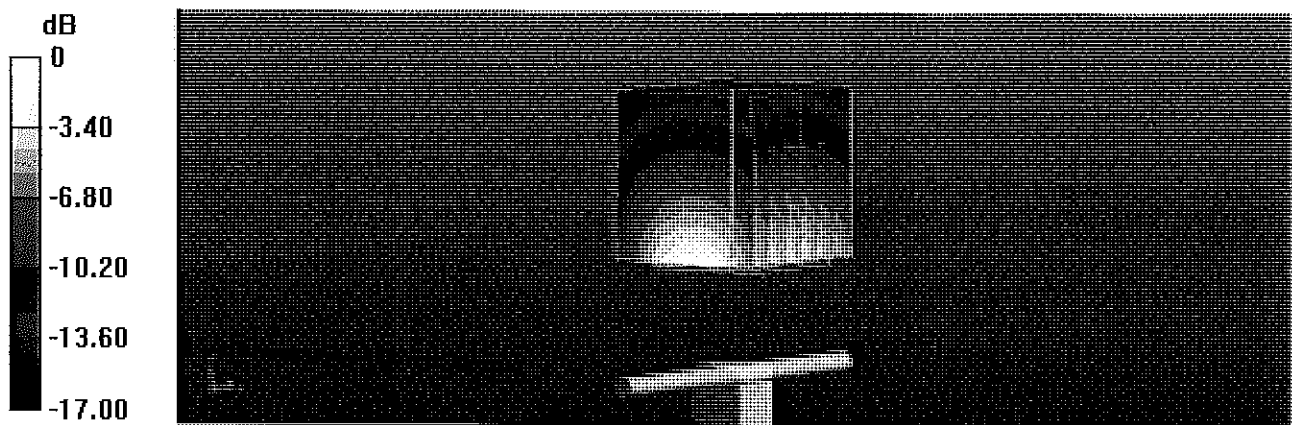

0 dB = 14.5 W/kg = 11.61 dBW/kg

# Impedance Measurement Plot for Body TSL

10 May 2017 10:15:44  
[CH1] S11 1 U FS 1: 47.309  $\Omega$  3.8281  $\Omega$  739.49 pF 1 900.000 000 MHz

\*  
De1  
CA

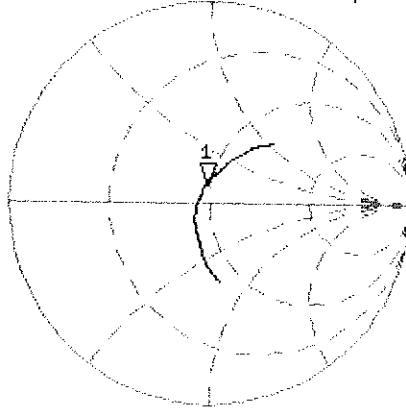

Avg  
16

H1 d

CH2 S11 LOG 5 dB/REF -20 dB 1: -20.492 dB 1 900.000 000 MHz

CA

Avg  
16

H1 d

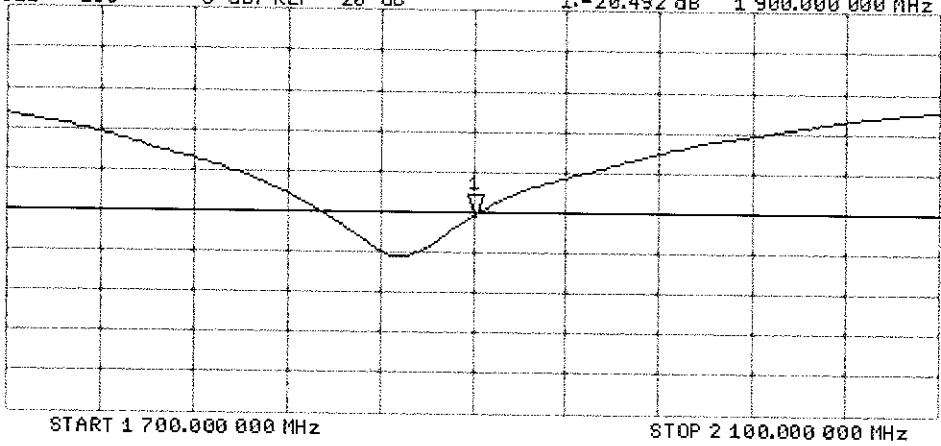



Accredited by the Swiss Accreditation Service (SAS)  
The Swiss Accreditation Service is one of the signatories to the EA  
Multilateral Agreement for the recognition of calibration certificates

Accreditation No.: **SCS 0108**

Client **PC Test**

Certificate No: **D2450V2-945\_May17**

## CALIBRATION CERTIFICATE

Object **D2450V2 - SN:945**

Calibration procedure(s) **QA CAL-05.v9  
Calibration procedure for dipole validation kits above 700 MHz**

Calibration date: **May 09, 2017**

*BN ✓  
05-23-2017*

This calibration certificate documents the traceability to national standards, which realize the physical units of measurements (SI).  
The measurements and the uncertainties with confidence probability are given on the following pages and are part of the certificate.

All calibrations have been conducted in the closed laboratory facility: environment temperature  $(22 \pm 3)^\circ\text{C}$  and humidity  $< 70\%$ .

Calibration Equipment used (M&TE critical for calibration)

Primary Standards	ID #	Cal Date (Certificate No.)	Scheduled Calibration
Power meter NRP	SN: 104778	04-Apr-17 (No. 217-02521/02522)	Apr-18
Power sensor NRP-Z91	SN: 103244	04-Apr-17 (No. 217-02521)	Apr-18
Power sensor NRP-Z91	SN: 103245	04-Apr-17 (No. 217-02522)	Apr-18
Reference 20 dB Attenuator	SN: 5058 (20k)	07-Apr-17 (No. 217-02528)	Apr-18
Type-N mismatch combination	SN: 5047.2 / 06327	07-Apr-17 (No. 217-02529)	Apr-18
Reference Probe EX3DV4	SN: 7349	31-Dec-16 (No. EX3-7349_Dec16)	Dec-17
DAE4	SN: 601	28-Mar-17 (No. DAE4-601_Mar17)	Mar-18
Secondary Standards	ID #	Check Date (in house)	Scheduled Check
Power meter EPM-442A	SN: GB37480704	07-Oct-15 (in house check Oct-16)	In house check: Oct-18
Power sensor HP 8481A	SN: US37292783	07-Oct-15 (in house check Oct-16)	In house check: Oct-18
Power sensor HP 8481A	SN: MY41092317	07-Oct-15 (in house check Oct-16)	In house check: Oct-18
RF generator R&S SMT-06	SN: 100972	15-Jun-15 (in house check Oct-16)	In house check: Oct-18
Network Analyzer HP 8753E	SN: US37390585	18-Oct-01 (in house check Oct-16)	In house check: Oct-17

Calibrated by: **Claudio Leubler**      **Laboratory Technician**

Signature

Approved by: **Katja Pokovic**      **Technical Manager**

Issued: May 11, 2017

This calibration certificate shall not be reproduced except in full without written approval of the laboratory.



Accredited by the Swiss Accreditation Service (SAS)  
The Swiss Accreditation Service is one of the signatories to the EA  
Multilateral Agreement for the recognition of calibration certificates

Accreditation No.: **SCS 0108**

### Glossary:

TSL	tissue simulating liquid
ConvF	sensitivity in TSL / NORM x,y,z
N/A	not applicable or not measured

### Calibration is Performed According to the Following Standards:

- IEEE Std 1528-2013, "IEEE Recommended Practice for Determining the Peak Spatial-Averaged Specific Absorption Rate (SAR) in the Human Head from Wireless Communications Devices: Measurement Techniques", June 2013
- IEC 62209-1, "Procedure to measure the Specific Absorption Rate (SAR) for hand-held devices used in close proximity to the ear (frequency range of 300 MHz to 3 GHz)", February 2005
- IEC 62209-2, "Procedure to determine the Specific Absorption Rate (SAR) for wireless communication devices used in close proximity to the human body (frequency range of 30 MHz to 6 GHz)", March 2010
- KDB 865664, "SAR Measurement Requirements for 100 MHz to 6 GHz"

### Additional Documentation:

- DASY4/5 System Handbook

### Methods Applied and Interpretation of Parameters:

- Measurement Conditions:** Further details are available from the Validation Report at the end of the certificate. All figures stated in the certificate are valid at the frequency indicated.
- Antenna Parameters with TSL:** The dipole is mounted with the spacer to position its feed point exactly below the center marking of the flat phantom section, with the arms oriented parallel to the body axis.
- Feed Point Impedance and Return Loss:** These parameters are measured with the dipole positioned under the liquid filled phantom. The impedance stated is transformed from the measurement at the SMA connector to the feed point. The Return Loss ensures low reflected power. No uncertainty required.
- Electrical Delay:** One-way delay between the SMA connector and the antenna feed point. No uncertainty required.
- SAR measured:** SAR measured at the stated antenna input power.
- SAR normalized:** SAR as measured, normalized to an input power of 1 W at the antenna connector.
- SAR for nominal TSL parameters:** The measured TSL parameters are used to calculate the nominal SAR result.

The reported uncertainty of measurement is stated as the standard uncertainty of measurement multiplied by the coverage factor  $k=2$ , which for a normal distribution corresponds to a coverage probability of approximately 95%.



## Measurement Conditions

DASY system configuration, as far as not given on page 1.

DASY Version	DASY5	V52.10.0
Extrapolation	Advanced Extrapolation	
Phantom	Modular Flat Phantom	
Distance Dipole Center - TSL	10 mm	with Spacer
Zoom Scan Resolution	dx, dy, dz = 5 mm	
Frequency	2450 MHz $\pm$ 1 MHz	

## Head TSL parameters

The following parameters and calculations were applied.

	Temperature	Permittivity	Conductivity
Nominal Head TSL parameters	22.0 °C	39.2	1.80 mho/m
Measured Head TSL parameters	(22.0 $\pm$ 0.2) °C	37.9 $\pm$ 6 %	1.88 mho/m $\pm$ 6 %
Head TSL temperature change during test	< 0.5 °C	----	----

## SAR result with Head TSL

SAR averaged over 1 cm <sup>3</sup> (1 g) of Head TSL	Condition	
SAR measured	250 mW input power	13.2 W/kg
SAR for nominal Head TSL parameters	normalized to 1W	51.3 W/kg $\pm$ 17.0 % (k=2)

SAR averaged over 10 cm <sup>3</sup> (10 g) of Head TSL	condition	
SAR measured	250 mW input power	6.08 W/kg
SAR for nominal Head TSL parameters	normalized to 1W	23.9 W/kg $\pm$ 16.5 % (k=2)

## Body TSL parameters

The following parameters and calculations were applied.

	Temperature	Permittivity	Conductivity
Nominal Body TSL parameters	22.0 °C	52.7	1.95 mho/m
Measured Body TSL parameters	(22.0 $\pm$ 0.2) °C	52.4 $\pm$ 6 %	2.03 mho/m $\pm$ 6 %
Body TSL temperature change during test	< 0.5 °C	----	----

## SAR result with Body TSL

SAR averaged over 1 cm <sup>3</sup> (1 g) of Body TSL	Condition	
SAR measured	250 mW input power	12.8 W/kg
SAR for nominal Body TSL parameters	normalized to 1W	50.2 W/kg $\pm$ 17.0 % (k=2)

SAR averaged over 10 cm <sup>3</sup> (10 g) of Body TSL	condition	
SAR measured	250 mW input power	5.98 W/kg
SAR for nominal Body TSL parameters	normalized to 1W	23.7 W/kg $\pm$ 16.5 % (k=2)

## Appendix (Additional assessments outside the scope of SCS 0108)

### Antenna Parameters with Head TSL

Impedance, transformed to feed point	55.3 $\Omega$ + 1.8 j $\Omega$
Return Loss	- 25.4 dB

### Antenna Parameters with Body TSL

Impedance, transformed to feed point	50.6 $\Omega$ + 3.6 j $\Omega$
Return Loss	- 28.8 dB

### General Antenna Parameters and Design

Electrical Delay (one direction)	1.157 ns
----------------------------------	----------

After long term use with 100W radiated power, only a slight warming of the dipole near the feedpoint can be measured.

The dipole is made of standard semirigid coaxial cable. The center conductor of the feeding line is directly connected to the second arm of the dipole. The antenna is therefore short-circuited for DC-signals. On some of the dipoles, small end caps are added to the dipole arms in order to improve matching when loaded according to the position as explained in the "Measurement Conditions" paragraph. The SAR data are not affected by this change. The overall dipole length is still according to the Standard.

No excessive force must be applied to the dipole arms, because they might bend or the soldered connections near the feedpoint may be damaged.

### Additional EUT Data

Manufactured by	SPEAG
Manufactured on	March 15, 2014

## DASY5 Validation Report for Head TSL

Date: 09.05.2017

Test Laboratory: SPEAG, Zurich, Switzerland

**DUT: Dipole 2450 MHz; Type: D2450V2; Serial: D2450V2 - SN:945**

Communication System: UID 0 - CW; Frequency: 2450 MHz

Medium parameters used:  $f = 2450$  MHz;  $\sigma = 1.88$  S/m;  $\epsilon_r = 37.9$ ;  $\rho = 1000$  kg/m<sup>3</sup>

Phantom section: Flat Section

Measurement Standard: DASY5 (IEEE/IEC/ANSI C63.19-2011)

DASY52 Configuration:

- Probe: EX3DV4 - SN7349; ConvF(7.72, 7.72, 7.72); Calibrated: 31.12.2016;
- Sensor-Surface: 1.4mm (Mechanical Surface Detection)
- Electronics: DAE4 Sn601; Calibrated: 28.03.2017
- Phantom: Flat Phantom 5.0 (front); Type: QD 000 P50 AA; Serial: 1001
- DASY52 52.10.0(1442); SEMCAD X 14.6.10(7413)

### **Dipole Calibration for Head Tissue/Pin=250 mW, d=10mm/Zoom Scan (7x7x7)/Cube 0:**

Measurement grid: dx=5mm, dy=5mm, dz=5mm

Reference Value = 114.4 V/m; Power Drift = -0.03 dB

Peak SAR (extrapolated) = 27.3 W/kg

**SAR(1 g) = 13.2 W/kg; SAR(10 g) = 6.08 W/kg**

Maximum value of SAR (measured) = 22.0 W/kg

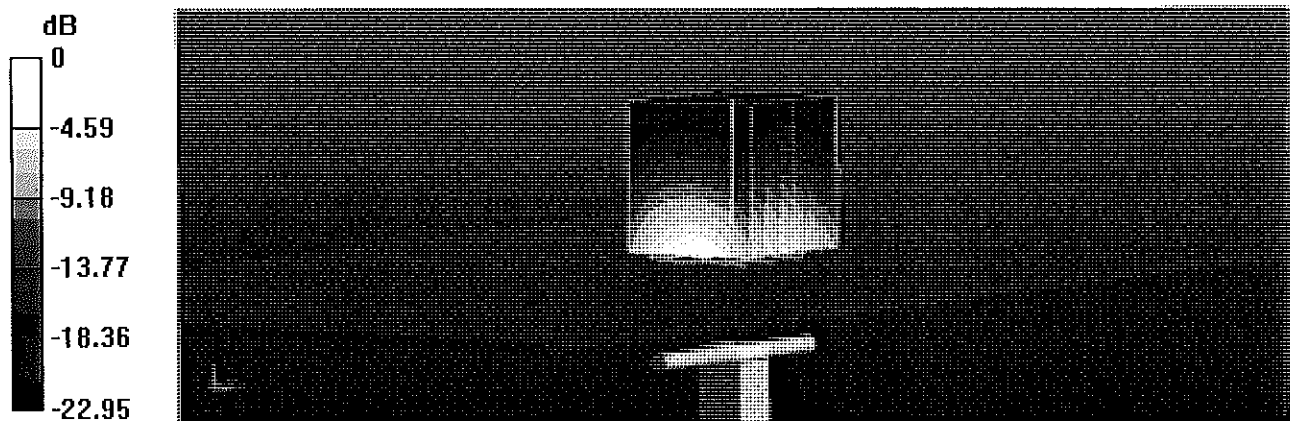

0 dB = 22.0 W/kg = 13.42 dBW/kg

# Impedance Measurement Plot for Head TSL

9 May 2017 12:55:53

CH1 S11 1 U FS 1: 55.334  $\Omega$  1.8242  $\Omega$  118.50  $\mu$ H 2 450.000 000 MHz

\*  
De1  
CA  
Avg  
16  
H1d

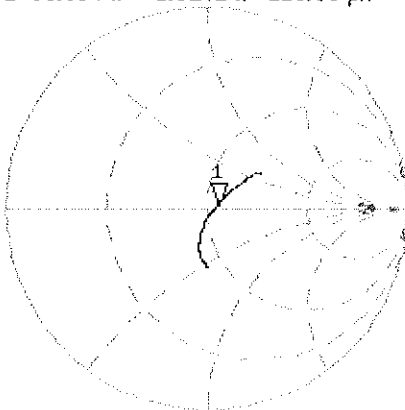

CH2 S11 LOG 5 dB/REF -20 dB 1:-25.428 dB 2 450.000 000 MHz

CA  
Avg  
16  
H1d

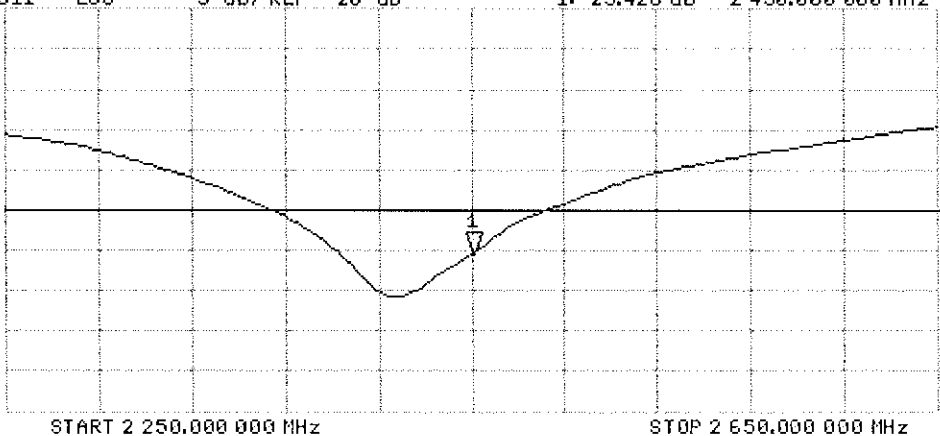

## DASY5 Validation Report for Body TSL

Date: 09.05.2017

Test Laboratory: SPEAG, Zurich, Switzerland

**DUT: Dipole 2450 MHz; Type: D2450V2; Serial: D2450V2 - SN:945**

Communication System: UID 0 - CW; Frequency: 2450 MHz

Medium parameters used:  $f = 2450$  MHz;  $\sigma = 2.03$  S/m;  $\epsilon_r = 52.4$ ;  $\rho = 1000$  kg/m<sup>3</sup>

Phantom section: Flat Section

Measurement Standard: DASY5 (IEEE/IEC/ANSI C63.19-2011)

DASY52 Configuration:

- Probe: EX3DV4 - SN7349; ConvF(7.79, 7.79, 7.79); Calibrated: 31.12.2016;
- Sensor-Surface: 1.4mm (Mechanical Surface Detection)
- Electronics: DAE4 Sn601; Calibrated: 28.03.2017
- Phantom: Flat Phantom 5.0 (back); Type: QD 000 P50 AA; Serial: 1002
- DASY52 52.10.0(1442); SEMCAD X 14.6.10(7413)

### Dipole Calibration for Body Tissue/Pin=250 mW, d=10mm/Zoom Scan (7x7x7)/Cube 0:

Measurement grid: dx=5mm, dy=5mm, dz=5mm

Reference Value = 104.8 V/m; Power Drift = -0.08 dB

Peak SAR (extrapolated) = 25.3 W/kg

**SAR(1 g) = 12.8 W/kg; SAR(10 g) = 5.98 W/kg**

Maximum value of SAR (measured) = 19.9 W/kg

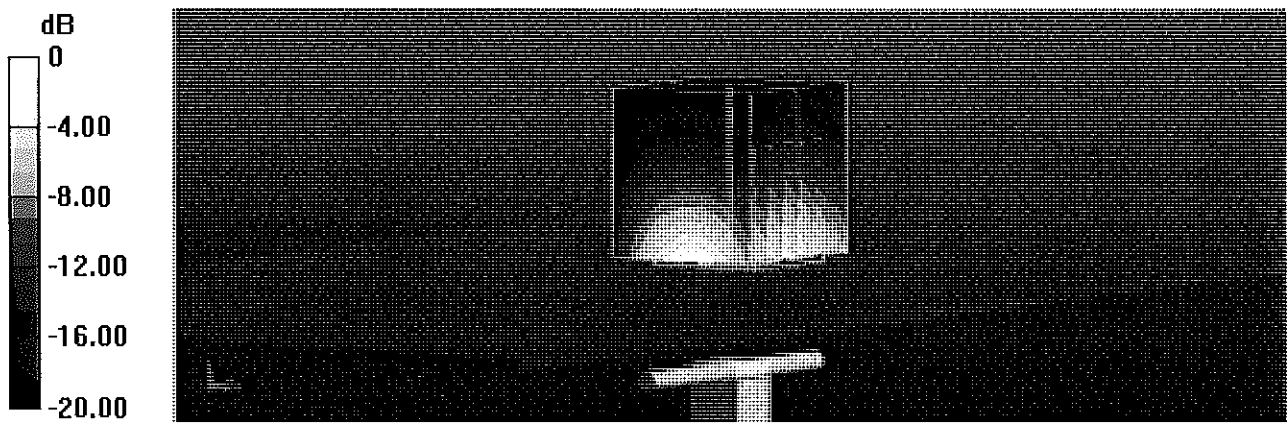

0 dB = 19.9 W/kg = 12.99 dBW/kg

# Impedance Measurement Plot for Body TSL

9 May 2017 12:55:22

CH1 S11 1 U FS 1: 50.646  $\Omega$  3.6074  $\Omega$  234.34 pF 2 450.000 000 MHz

\*  
De1

CΔ

Avg  
16

H1 d

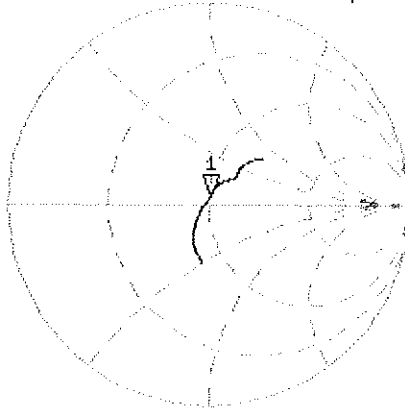

CH2 S11 LOG 5 dB/REF -20 dB 1: -28.766 dB 2 450.000 000 MHz

CΔ

Avg  
16

H1 d

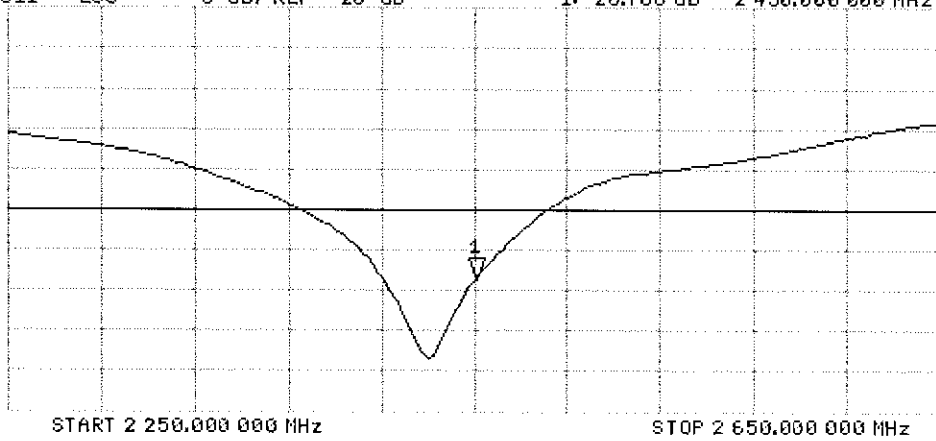



Accredited by the Swiss Accreditation Service (SAS)  
The Swiss Accreditation Service is one of the signatories to the EA  
Multilateral Agreement for the recognition of calibration certificates

Accreditation No.: **SCS 0108**

Client **PC Test**

Certificate No: **D2450V2-797\_Sep16**

## CALIBRATION CERTIFICATE

Object **D2450V2 - SN:797**

Calibration procedure(s) **QA CAL-05.v9**  
**Calibration procedure for dipole validation kits above 700 MHz**

*BNV*  
*09-28-2016*

Calibration date: **September 13, 2016**

This calibration certificate documents the traceability to national standards, which realize the physical units of measurements (SI).  
The measurements and the uncertainties with confidence probability are given on the following pages and are part of the certificate.

All calibrations have been conducted in the closed laboratory facility: environment temperature (22 ± 3)°C and humidity < 70%.

Calibration Equipment used (M&TE critical for calibration)

Primary Standards	ID #	Cal Date (Certificate No.)	Scheduled Calibration
Power meter NRP	SN: 104778	06-Apr-16 (No. 217-02288/02289)	Apr-17
Power sensor NRP-Z91	SN: 103244	06-Apr-16 (No. 217-02288)	Apr-17
Power sensor NRP-Z91	SN: 103245	06-Apr-16 (No. 217-02289)	Apr-17
Reference 20 dB Attenuator	SN: 5058 (20k)	05-Apr-16 (No. 217-02292)	Apr-17
Type-N mismatch combination	SN: 5047.2 / 06327	05-Apr-16 (No. 217-02295)	Apr-17
Reference Probe EX3DV4	SN: 7349	15-Jun-16 (No. EX3-7349_Jun16)	Jun-17
DAE4	SN: 601	30-Dec-15 (No. DAE4-601_Dec15)	Dec-16

Secondary Standards	ID #	Check Date (in house)	Scheduled Check
Power meter EPM-442A	SN: GB37480704	07-Oct-15 (No. 217-02222)	In house check: Oct-16
Power sensor HP 8481A	SN: US37292783	07-Oct-15 (No. 217-02222)	In house check: Oct-16
Power sensor HP 8481A	SN: MY41092317	07-Oct-15 (No. 217-02223)	In house check: Oct-16
RF generator R&S SMT-06	SN: 100972	15-Jun-15 (in house check Jun-15)	In house check: Oct-16
Network Analyzer HP 8753E	SN: US37390585	18-Oct-01 (in house check Oct-15)	In house check: Oct-16

Calibrated by: **Jeton Kastrati**      Function: **Laboratory Technician**

Approved by: **Katja Pokovic**      Technical Manager

Signature  
*[Handwritten Signature]*

Issued: September 13, 2016

This calibration certificate shall not be reproduced except in full without written approval of the laboratory.



Accredited by the Swiss Accreditation Service (SAS)  
The Swiss Accreditation Service is one of the signatories to the EA  
Multilateral Agreement for the recognition of calibration certificates

**Glossary:**

TSL	tissue simulating liquid
ConvF	sensitivity in TSL / NORM x,y,z
N/A	not applicable or not measured

**Calibration is Performed According to the Following Standards:**

- a) IEEE Std 1528-2013, "IEEE Recommended Practice for Determining the Peak Spatial-Averaged Specific Absorption Rate (SAR) in the Human Head from Wireless Communications Devices: Measurement Techniques", June 2013
- b) IEC 62209-1, "Procedure to measure the Specific Absorption Rate (SAR) for hand-held devices used in close proximity to the ear (frequency range of 300 MHz to 3 GHz)", February 2005
- c) IEC 62209-2, "Procedure to determine the Specific Absorption Rate (SAR) for wireless communication devices used in close proximity to the human body (frequency range of 30 MHz to 6 GHz)", March 2010
- d) KDB 865664, "SAR Measurement Requirements for 100 MHz to 6 GHz"

**Additional Documentation:**

- e) DASY4/5 System Handbook

**Methods Applied and Interpretation of Parameters:**

- *Measurement Conditions:* Further details are available from the Validation Report at the end of the certificate. All figures stated in the certificate are valid at the frequency indicated.
- *Antenna Parameters with TSL:* The dipole is mounted with the spacer to position its feed point exactly below the center marking of the flat phantom section, with the arms oriented parallel to the body axis.
- *Feed Point Impedance and Return Loss:* These parameters are measured with the dipole positioned under the liquid filled phantom. The impedance stated is transformed from the measurement at the SMA connector to the feed point. The Return Loss ensures low reflected power. No uncertainty required.
- *Electrical Delay:* One-way delay between the SMA connector and the antenna feed point. No uncertainty required.
- *SAR measured:* SAR measured at the stated antenna input power.
- *SAR normalized:* SAR as measured, normalized to an input power of 1 W at the antenna connector.
- *SAR for nominal TSL parameters:* The measured TSL parameters are used to calculate the nominal SAR result.

The reported uncertainty of measurement is stated as the standard uncertainty of measurement multiplied by the coverage factor  $k=2$ , which for a normal distribution corresponds to a coverage probability of approximately 95%.



## Measurement Conditions

DASY system configuration, as far as not given on page 1.

DASY Version	DASY5	V52.8.8
Extrapolation	Advanced Extrapolation	
Phantom	Modular Flat Phantom	
Distance Dipole Center - TSL	10 mm	with Spacer
Zoom Scan Resolution	dx, dy, dz = 5 mm	
Frequency	2450 MHz $\pm$ 1 MHz	

## Head TSL parameters

The following parameters and calculations were applied.

	Temperature	Permittivity	Conductivity
Nominal Head TSL parameters	22.0 °C	39.2	1.80 mho/m
Measured Head TSL parameters	(22.0 $\pm$ 0.2) °C	37.9 $\pm$ 6 %	1.88 mho/m $\pm$ 6 %
Head TSL temperature change during test	< 0.5 °C	----	----

## SAR result with Head TSL

SAR averaged over 1 cm <sup>3</sup> (1 g) of Head TSL	Condition	
SAR measured	250 mW input power	13.4 W/kg
SAR for nominal Head TSL parameters	normalized to 1W	52.1 W/kg $\pm$ 17.0 % (k=2)

SAR averaged over 10 cm <sup>3</sup> (10 g) of Head TSL	condition	
SAR measured	250 mW input power	6.26 W/kg
SAR for nominal Head TSL parameters	normalized to 1W	24.6 W/kg $\pm$ 16.5 % (k=2)

## Body TSL parameters

The following parameters and calculations were applied.

	Temperature	Permittivity	Conductivity
Nominal Body TSL parameters	22.0 °C	52.7	1.95 mho/m
Measured Body TSL parameters	(22.0 $\pm$ 0.2) °C	51.6 $\pm$ 6 %	2.04 mho/m $\pm$ 6 %
Body TSL temperature change during test	< 0.5 °C	----	----

## SAR result with Body TSL

SAR averaged over 1 cm <sup>3</sup> (1 g) of Body TSL	Condition	
SAR measured	250 mW input power	13.0 W/kg
SAR for nominal Body TSL parameters	normalized to 1W	50.7 W/kg $\pm$ 17.0 % (k=2)

SAR averaged over 10 cm <sup>3</sup> (10 g) of Body TSL	condition	
SAR measured	250 mW input power	6.13 W/kg
SAR for nominal Body TSL parameters	normalized to 1W	24.2 W/kg $\pm$ 16.5 % (k=2)

## Appendix (Additional assessments outside the scope of SCS 0108)

### Antenna Parameters with Head TSL

Impedance, transformed to feed point	53.8 $\Omega$ + 6.0 j $\Omega$
Return Loss	- 23.3 dB

### Antenna Parameters with Body TSL

Impedance, transformed to feed point	50.8 $\Omega$ + 8.0 j $\Omega$
Return Loss	- 22.0 dB

### General Antenna Parameters and Design

Electrical Delay (one direction)	1.160 ns
----------------------------------	----------

After long term use with 100W radiated power, only a slight warming of the dipole near the feedpoint can be measured.

The dipole is made of standard semirigid coaxial cable. The center conductor of the feeding line is directly connected to the second arm of the dipole. The antenna is therefore short-circuited for DC-signals. On some of the dipoles, small end caps are added to the dipole arms in order to improve matching when loaded according to the position as explained in the "Measurement Conditions" paragraph. The SAR data are not affected by this change. The overall dipole length is still according to the Standard.

No excessive force must be applied to the dipole arms, because they might bend or the soldered connections near the feedpoint may be damaged.

### Additional EUT Data

Manufactured by	SPEAG
Manufactured on	January 24, 2006

## DASY5 Validation Report for Head TSL

Date: 13.09.2016

Test Laboratory: SPEAG, Zurich, Switzerland

**DUT: Dipole 2450 MHz; Type: D2450V2; Serial: D2450V2 - SN:797**

Communication System: UID 0 - CW; Frequency: 2450 MHz

Medium parameters used:  $f = 2450$  MHz;  $\sigma = 1.88$  S/m;  $\epsilon_r = 37.9$ ;  $\rho = 1000$  kg/m<sup>3</sup>

Phantom section: Flat Section

Measurement Standard: DASY5 (IEEE/IEC/ANSI C63.19-2011)

DASY52 Configuration:

- Probe: EX3DV4 - SN7349; ConvF(7.72, 7.72, 7.72); Calibrated: 15.06.2016;
- Sensor-Surface: 1.4mm (Mechanical Surface Detection)
- Electronics: DAE4 Sn601; Calibrated: 30.12.2015
- Phantom: Flat Phantom 5.0 (front); Type: QD000P50AA; Serial: 1001
- DASY52 52.8.8(1258); SEMCAD X 14.6.10(7372)

### Dipole Calibration for Head Tissue/Pin=250 mW, d=10mm/Zoom Scan (7x7x7)/Cube 0:

Measurement grid: dx=5mm, dy=5mm, dz=5mm

Reference Value = 113.4 V/m; Power Drift = -0.02 dB

Peak SAR (extrapolated) = 26.9 W/kg

**SAR(1 g) = 13.4 W/kg; SAR(10 g) = 6.26 W/kg**

Maximum value of SAR (measured) = 21.9 W/kg

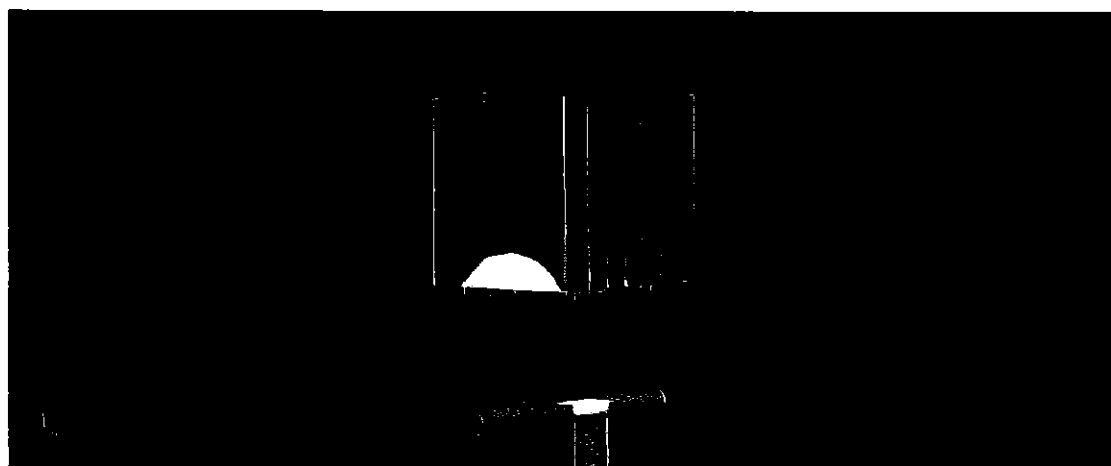
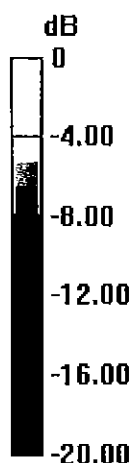

0 dB = 21.9 W/kg = 13.40 dBW/kg

# Impedance Measurement Plot for Head TSL

12 Sep 2016 12:42:03

CH1 S11 1 U FS 2: 53.771  $\Omega$  6.0234  $\Omega$  391.29  $\mu$ H 2 450.000 000 MHz

\*  
De1  
CA

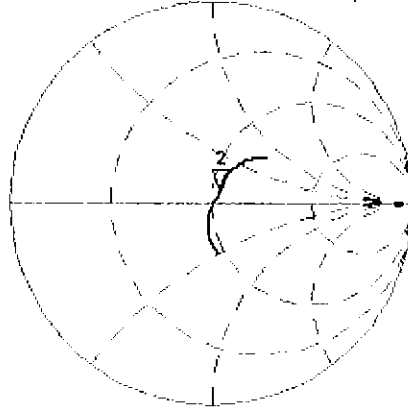

Avg  
16

H1d

CH2 S11 LOG 5 dB/REF -20 dB 2:-23.300 dB 2 450.000 000 MHz

CA

Avg  
16

H1d

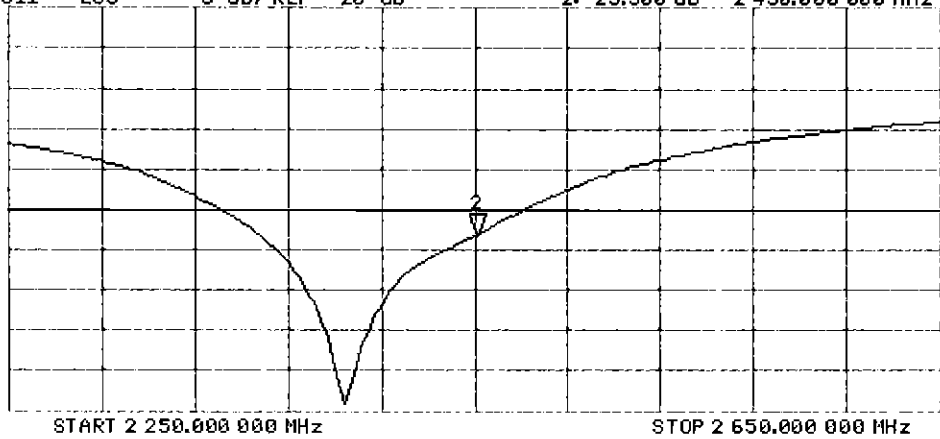

## DASY5 Validation Report for Body TSL

Date: 13.09.2016

Test Laboratory: SPEAG, Zurich, Switzerland

**DUT: Dipole 2450 MHz; Type: D2450V2; Serial: D2450V2 - SN:797**

Communication System: UID 0 - CW; Frequency: 2450 MHz

Medium parameters used:  $f = 2450$  MHz;  $\sigma = 2.04$  S/m;  $\epsilon_r = 51.6$ ;  $\rho = 1000$  kg/m<sup>3</sup>

Phantom section: Flat Section

Measurement Standard: DASY5 (IEEE/IEC/ANSI C63.19-2011)

DASY52 Configuration:

- Probe: EX3DV4 - SN7349; ConvF(7.79, 7.79, 7.79); Calibrated: 15.06.2016;
- Sensor-Surface: 1.4mm (Mechanical Surface Detection)
- Electronics: DAE4 Sn601; Calibrated: 30.12.2015
- Phantom: Flat Phantom 5.0 (back); Type: QD000P50AA; Serial: 1002
- DASY52 52.8.8(1258); SEMCAD X 14.6.10(7372)

### Dipole Calibration for Body Tissue/Pin=250 mW, d=10mm/Zoom Scan (7x7x7)/Cube 0:

Measurement grid: dx=5mm, dy=5mm, dz=5mm

Reference Value = 106.5 V/m; Power Drift = -0.04 dB

Peak SAR (extrapolated) = 25.6 W/kg

**SAR(1 g) = 13 W/kg; SAR(10 g) = 6.13 W/kg**

Maximum value of SAR (measured) = 21.2 W/kg

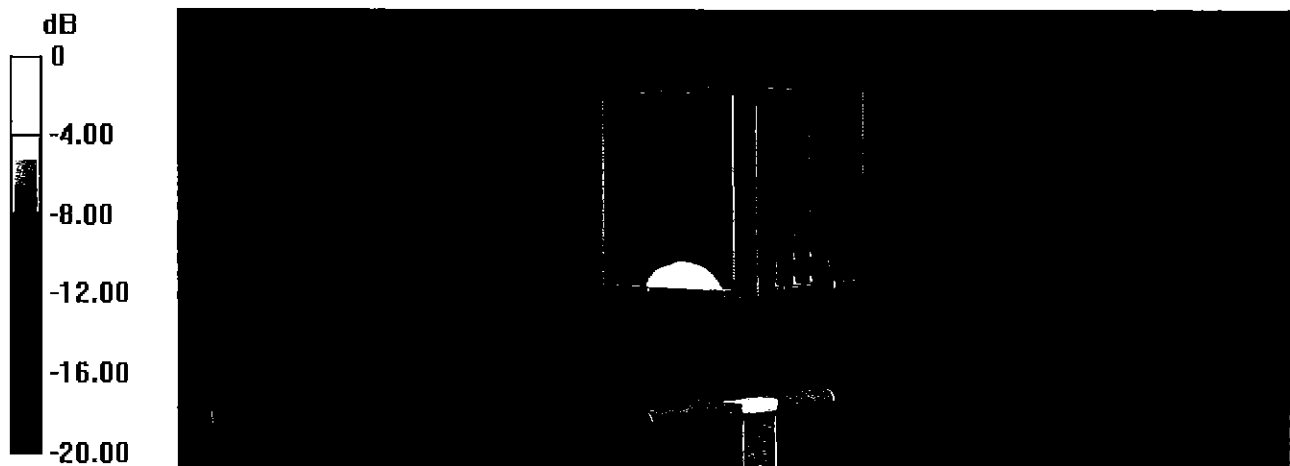

0 dB = 21.2 W/kg = 13.26 dBW/kg

# Impedance Measurement Plot for Body TSL

12 Sep 2016 12:40:39

CH1 S11 1 U FS 2: 50.842  $\Omega$  7.9531  $\Omega$  516.64  $\mu\text{H}$  2 450.000 000 MHz

\*  
De1  
CA  
Avg  
16  
H1d

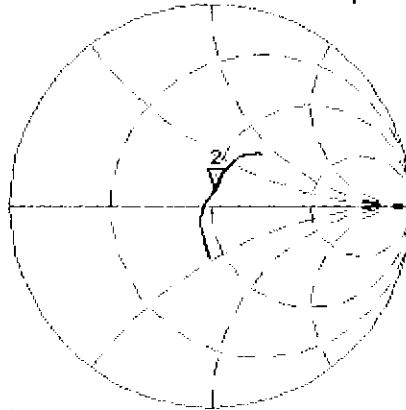

CH2 S11 LOG 5 dB/REF -20 dB 2:-22.037 dB 2 450.000 000 MHz

CA  
Avg  
16  
H1d

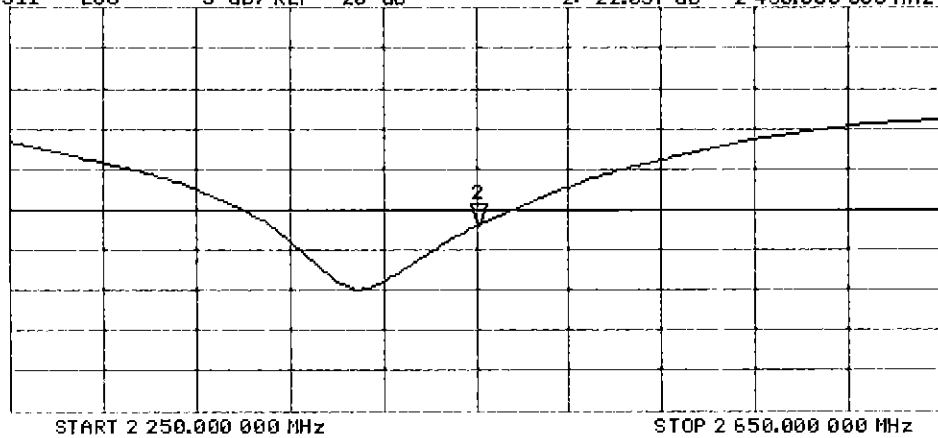



Accredited by the Swiss Accreditation Service (SAS)  
The Swiss Accreditation Service is one of the signatories to the EA  
Multilateral Agreement for the recognition of calibration certificates

Accreditation No.: **SCS 0108**

Client **PC Test**

Certificate No: **D2600V2-1004\_Apr17**

## CALIBRATION CERTIFICATE

Object **D2600V2 - SN:1004**

Calibration procedure(s) **QA CAL-05.v9**  
**Calibration procedure for dipole validation kits above 700 MHz**

Calibration date: **April 13, 2017**

*BNW  
5-3-2017*

This calibration certificate documents the traceability to national standards, which realize the physical units of measurements (SI).  
The measurements and the uncertainties with confidence probability are given on the following pages and are part of the certificate.

All calibrations have been conducted in the closed laboratory facility: environment temperature ( $22 \pm 3$ )°C and humidity < 70%.

Calibration Equipment used (M&TE critical for calibration)

Primary Standards	ID #	Cal Date (Certificate No.)	Scheduled Calibration
Power meter NRP	SN: 104778	04-Apr-17 (No. 217-02521/02522)	Apr-18
Power sensor NRP-Z91	SN: 103244	04-Apr-17 (No. 217-02521)	Apr-18
Power sensor NRP-Z91	SN: 103245	04-Apr-17 (No. 217-02522)	Apr-18
Reference 20 dB Attenuator	SN: 5058 (20k)	07-Apr-17 (No. 217-02528)	Apr-18
Type-N mismatch combination	SN: 5047.2 / 06327	07-Apr-17 (No. 217-02529)	Apr-18
Reference Probe EX3DV4	SN: 7349	31-Dec-16 (No. EX3-7349_Dec16)	Dec-17
DAE4	SN: 601	28-Mar-17 (No. DAE4-601_Mar17)	Mar-18

Secondary Standards	ID #	Check Date (in house)	Scheduled Check
Power meter EPM-442A	SN: GB37480704	07-Oct-15 (in house check Oct-16)	In house check: Oct-18
Power sensor HP 8481A	SN: US37292783	07-Oct-15 (in house check Oct-16)	In house check: Oct-18
Power sensor HP 8481A	SN: MY41092317	07-Oct-15 (in house check Oct-16)	In house check: Oct-18
RF generator R&S SMT-06	SN: 100972	15-Jun-15 (in house check Oct-16)	In house check: Oct-18
Network Analyzer HP 8753E	SN: US37390585	18-Oct-01 (in house check Oct-16)	In house check: Oct-17

Calibrated by: **Michael Weber**      Name: Michael Weber      Function: Laboratory Technician

Signature: *M. Weber*

Approved by: **Katja Pokovic**      Name: Katja Pokovic      Function: Technical Manager

Signature: *K. Pokovic*

Issued: April 18, 2017

This calibration certificate shall not be reproduced except in full without written approval of the laboratory.



Accredited by the Swiss Accreditation Service (SAS)  
The Swiss Accreditation Service is one of the signatories to the EA  
Multilateral Agreement for the recognition of calibration certificates

Accreditation No.: **SCS 0108**

### Glossary:

TSL	tissue simulating liquid
ConvF	sensitivity in TSL / NORM x,y,z
N/A	not applicable or not measured

### Calibration is Performed According to the Following Standards:

- IEEE Std 1528-2013, "IEEE Recommended Practice for Determining the Peak Spatial-Averaged Specific Absorption Rate (SAR) in the Human Head from Wireless Communications Devices: Measurement Techniques", June 2013
- IEC 62209-1, "Procedure to measure the Specific Absorption Rate (SAR) for hand-held devices used in close proximity to the ear (frequency range of 300 MHz to 3 GHz)", February 2005
- IEC 62209-2, "Procedure to determine the Specific Absorption Rate (SAR) for wireless communication devices used in close proximity to the human body (frequency range of 30 MHz to 6 GHz)", March 2010
- KDB 865664, "SAR Measurement Requirements for 100 MHz to 6 GHz"

### Additional Documentation:

- DASY4/5 System Handbook

### Methods Applied and Interpretation of Parameters:

- Measurement Conditions:** Further details are available from the Validation Report at the end of the certificate. All figures stated in the certificate are valid at the frequency indicated.
- Antenna Parameters with TSL:** The dipole is mounted with the spacer to position its feed point exactly below the center marking of the flat phantom section, with the arms oriented parallel to the body axis.
- Feed Point Impedance and Return Loss:** These parameters are measured with the dipole positioned under the liquid filled phantom. The impedance stated is transformed from the measurement at the SMA connector to the feed point. The Return Loss ensures low reflected power. No uncertainty required.
- Electrical Delay:** One-way delay between the SMA connector and the antenna feed point. No uncertainty required.
- SAR measured:** SAR measured at the stated antenna input power.
- SAR normalized:** SAR as measured, normalized to an input power of 1 W at the antenna connector.
- SAR for nominal TSL parameters:** The measured TSL parameters are used to calculate the nominal SAR result.

The reported uncertainty of measurement is stated as the standard uncertainty of measurement multiplied by the coverage factor  $k=2$ , which for a normal distribution corresponds to a coverage probability of approximately 95%.



## Measurement Conditions

DASY system configuration, as far as not given on page 1.

DASY Version	DASY5	V52.10.0
Extrapolation	Advanced Extrapolation	
Phantom	Modular Flat Phantom	
Distance Dipole Center - TSL	10 mm	with Spacer
Zoom Scan Resolution	dx, dy, dz = 5 mm	
Frequency	2600 MHz $\pm$ 1 MHz	

## Head TSL parameters

The following parameters and calculations were applied.

	Temperature	Permittivity	Conductivity
Nominal Head TSL parameters	22.0 °C	39.0	1.96 mho/m
Measured Head TSL parameters	(22.0 $\pm$ 0.2) °C	37.1 $\pm$ 6 %	2.03 mho/m $\pm$ 6 %
Head TSL temperature change during test	< 0.5 °C	----	----

## SAR result with Head TSL

SAR averaged over 1 cm <sup>3</sup> (1 g) of Head TSL	Condition	
SAR measured	250 mW input power	14.8 W/kg
SAR for nominal Head TSL parameters	normalized to 1W	57.6 W/kg $\pm$ 17.0 % (k=2)

SAR averaged over 10 cm <sup>3</sup> (10 g) of Head TSL	condition	
SAR measured	250 mW input power	6.54 W/kg
SAR for nominal Head TSL parameters	normalized to 1W	25.7 W/kg $\pm$ 16.5 % (k=2)

## Body TSL parameters

The following parameters and calculations were applied.

	Temperature	Permittivity	Conductivity
Nominal Body TSL parameters	22.0 °C	52.5	2.16 mho/m
Measured Body TSL parameters	(22.0 $\pm$ 0.2) °C	52.1 $\pm$ 6 %	2.21 mho/m $\pm$ 6 %
Body TSL temperature change during test	< 0.5 °C	----	----

## SAR result with Body TSL

SAR averaged over 1 cm <sup>3</sup> (1 g) of Body TSL	Condition	
SAR measured	250 mW input power	14.0 W/kg
SAR for nominal Body TSL parameters	normalized to 1W	55.3 W/kg $\pm$ 17.0 % (k=2)

SAR averaged over 10 cm <sup>3</sup> (10 g) of Body TSL	condition	
SAR measured	250 mW input power	6.26 W/kg
SAR for nominal Body TSL parameters	normalized to 1W	24.9 W/kg $\pm$ 16.5 % (k=2)

## Appendix (Additional assessments outside the scope of SCS 0108)

### Antenna Parameters with Head TSL

Impedance, transformed to feed point	48.5 $\Omega$ - 5.9 j $\Omega$
Return Loss	- 24.2 dB

### Antenna Parameters with Body TSL

Impedance, transformed to feed point	44.7 $\Omega$ - 4.9 j $\Omega$
Return Loss	- 22.4 dB

### General Antenna Parameters and Design

Electrical Delay (one direction)	1.149 ns
----------------------------------	----------

After long term use with 100W radiated power, only a slight warming of the dipole near the feedpoint can be measured.

The dipole is made of standard semirigid coaxial cable. The center conductor of the feeding line is directly connected to the second arm of the dipole. The antenna is therefore short-circuited for DC-signals. On some of the dipoles, small end caps are added to the dipole arms in order to improve matching when loaded according to the position as explained in the "Measurement Conditions" paragraph. The SAR data are not affected by this change. The overall dipole length is still according to the Standard.

No excessive force must be applied to the dipole arms, because they might bend or the soldered connections near the feedpoint may be damaged.

### Additional EUT Data

Manufactured by	SPEAG
Manufactured on	December 23, 2006

## DASY5 Validation Report for Head TSL

Date: 13.04.2017

Test Laboratory: SPEAG, Zurich, Switzerland

**DUT: Dipole 2600 MHz; Type: D2600V2; Serial: D2600V2 - SN: 1004**

Communication System: UID 0 - CW; Frequency: 2600 MHz

Medium parameters used:  $f = 2600$  MHz;  $\sigma = 2.03$  S/m;  $\epsilon_r = 37.1$ ;  $\rho = 1000$  kg/m<sup>3</sup>

Phantom section: Flat Section

Measurement Standard: DASY5 (IEEE/IEC/ANSI C63.19-2011)

DASY52 Configuration:

- Probe: EX3DV4 - SN7349; ConvF(7.56, 7.56, 7.56); Calibrated: 31.12.2016;
- Sensor-Surface: 1.4mm (Mechanical Surface Detection)
- Electronics: DAE4 Sn601; Calibrated: 28.03.2017
- Phantom: Flat Phantom 5.0 (front); Type: QD 000 P50 AA; Serial: 1001
- DASY52 52.10.0(1442); SEMCAD X 14.6.10(7413)

### **Dipole Calibration for Head Tissue/Pin=250 mW, d=10mm/Zoom Scan (7x7x7)/Cube 0:**

Measurement grid: dx=5mm, dy=5mm, dz=5mm

Reference Value = 115.4 V/m; Power Drift = -0.08 dB

Peak SAR (extrapolated) = 31.2 W/kg

**SAR(1 g) = 14.8 W/kg; SAR(10 g) = 6.54 W/kg**

Maximum value of SAR (measured) = 24.6 W/kg



0 dB = 24.6 W/kg = 13.91 dBW/kg

# Impedance Measurement Plot for Head TSL

13 Apr 2017 17:37:37

[CH1] S11 1 U FS

1: 48.477  $\Omega$  -5.8594  $\Omega$  10.447 pF

2 600.000 000 MHz

#  
De1

Cor

Avg  
16

H1 d

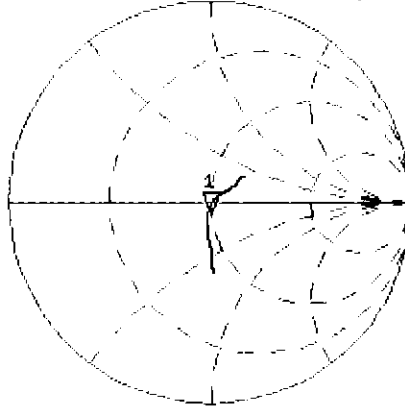

CH2 S11 LOG

5 dB/REF -20 dB

1: -24.237 dB

2 600.000 000 MHz

Cor

Avg  
16

H1 d

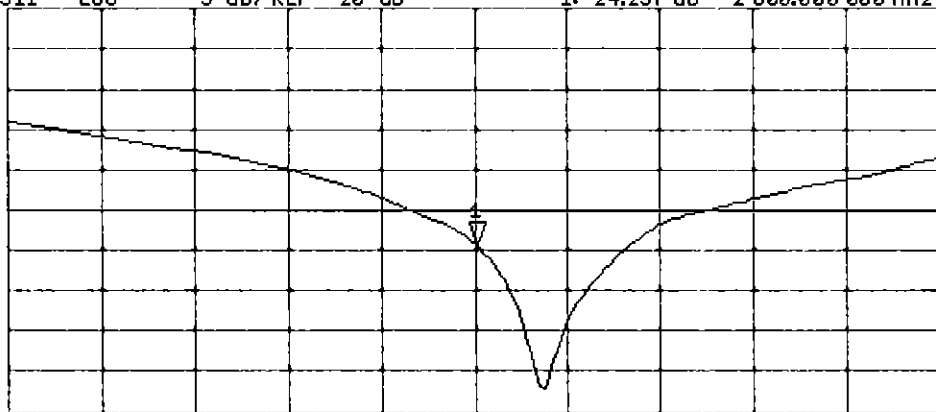

START 2 400.000 000 MHz

STOP 2 800.000 000 MHz

## DASY5 Validation Report for Body TSL

Date: 10.04.2017

Test Laboratory: SPEAG, Zurich, Switzerland

**DUT: Dipole 2600 MHz; Type: D2600V2; Serial: D2600V2 - SN: 1004**

Communication System: UID 0 - CW; Frequency: 2600 MHz

Medium parameters used:  $f = 2600$  MHz;  $\sigma = 2.21$  S/m;  $\epsilon_r = 52.1$ ;  $\rho = 1000$  kg/m<sup>3</sup>

Phantom section: Flat Section

Measurement Standard: DASY5 (IEEE/IEC/ANSI C63.19-2011)

DASY52 Configuration:

- Probe: EX3DV4 - SN7349; ConvF(7.48, 7.48, 7.48); Calibrated: 31.12.2016;
- Sensor-Surface: 1.4mm (Mechanical Surface Detection)
- Electronics: DAE4 Sn601; Calibrated: 28.03.2017
- Phantom: Flat Phantom 5.0 (back); Type: QD 000 P50 AA; Serial: 1002
- DASY52 52.10.0(1442); SEMCAD X 14.6.10(7413)

### Dipole Calibration for Body Tissue/Pin=250 mW, d=10mm/Zoom Scan (7x7x7)/Cube 0:

Measurement grid: dx=5mm, dy=5mm, dz=5mm

Reference Value = 107.3 V/m; Power Drift = -0.05 dB

Peak SAR (extrapolated) = 28.2 W/kg

**SAR(1 g) = 14 W/kg; SAR(10 g) = 6.26 W/kg**

Maximum value of SAR (measured) = 22.0 W/kg

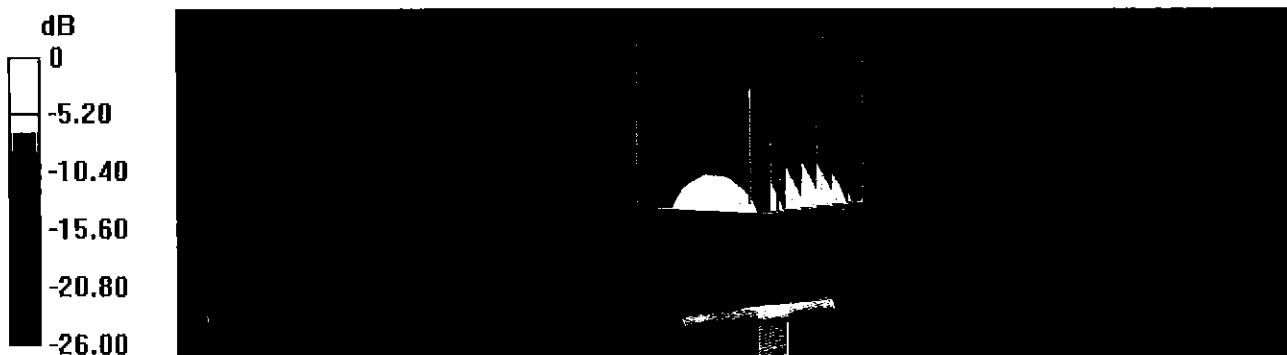

0 dB = 22.0 W/kg = 13.42 dBW/kg

# Impedance Measurement Plot for Body TSL

10 Apr 2017 14:58:52

CH1 S11 1 U FS

1: 44.701  $\Omega$  -4.8926  $\Omega$  12.511 pF

2 600.000 000 MHz

\*  
De1

CA

Avg  
16

H1d

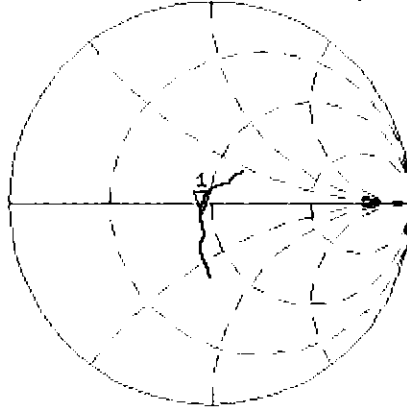

CH2 S11

LOG

5 dB/REF -20 dB

1: -22.378 dB 2 600.000 000 MHz

CA

Avg  
16

H1d

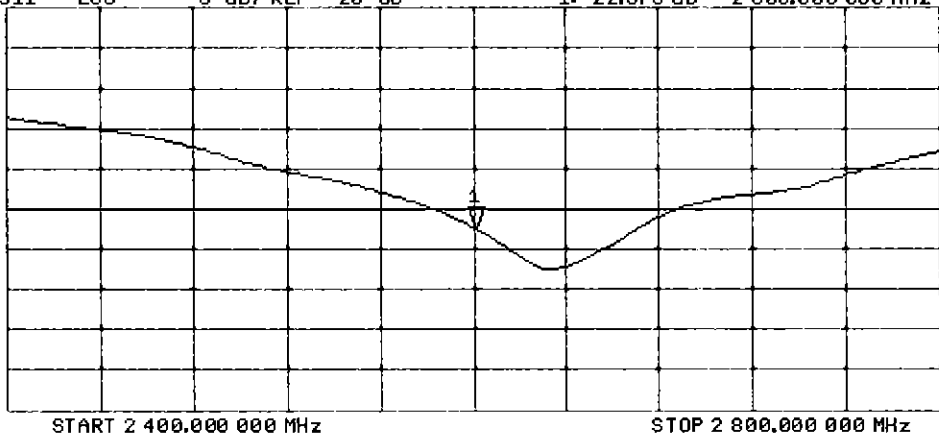



Accredited by the Swiss Accreditation Service (SAS)  
The Swiss Accreditation Service is one of the signatories to the EA  
Multilateral Agreement for the recognition of calibration certificates

Accreditation No.: **SCS 0108**

Client **PC Test**

Certificate No: **D5GHzV2-1123\_Mar17**

## CALIBRATION CERTIFICATE

Object **D5GHzV2 - SN:1123**

Calibration procedure(s) **QA CAL-22.v2  
Calibration procedure for dipole validation kits between 3-6 GHz**

*BNV  
03-27-2017*

Calibration date: **March 09, 2017**

This calibration certificate documents the traceability to national standards, which realize the physical units of measurements (SI).  
The measurements and the uncertainties with confidence probability are given on the following pages and are part of the certificate.

All calibrations have been conducted in the closed laboratory facility: environment temperature ( $22 \pm 3$ )°C and humidity < 70%.

Calibration Equipment used (M&TE critical for calibration)

Primary Standards	ID #	Cal Date (Certificate No.)	Scheduled Calibration
Power meter NRP	SN: 104778	06-Apr-16 (No. 217-02288/02289)	Apr-17
Power sensor NRP-Z91	SN: 103244	06-Apr-16 (No. 217-02288)	Apr-17
Power sensor NRP-Z91	SN: 103245	06-Apr-16 (No. 217-02289)	Apr-17
Reference 20 dB Attenuator	SN: 5058 (20k)	05-Apr-16 (No. 217-02292)	Apr-17
Type-N mismatch combination	SN: 5047.2 / 06327	05-Apr-16 (No. 217-02295)	Apr-17
Reference Probe EX3DV4	SN: 3503	31-Dec-16 (No. EX3-3503_Dec16)	Dec-17
DAE4	SN: 601	04-Jan-17 (No. DAE4-601_Jan17)	Jan-18
Secondary Standards	ID #	Check Date (in house)	Scheduled Check
Power meter EPM-442A	SN: GB37480704	07-Oct-15 (in house check Oct-16)	In house check: Oct-18
Power sensor HP 8481A	SN: US37292783	07-Oct-15 (in house check Oct-16)	In house check: Oct-18
Power sensor HP 8481A	SN: MY41092317	07-Oct-15 (in house check Oct-16)	In house check: Oct-18
RF generator R&S SMT-06	SN: 100972	15-Jun-15 (in house check Oct-16)	In house check: Oct-18
Network Analyzer HP 8753E	SN: US37390585	18-Oct-01 (in house check Oct-16)	In house check: Oct-17

Calibrated by: **Johannes Kurikka**      Function: **Laboratory Technician**

Signature

Approved by: **Katja Pokovic**      Technical Manager

Issued: March 10, 2017

This calibration certificate shall not be reproduced except in full without written approval of the laboratory.



Accredited by the Swiss Accreditation Service (SAS)  
The Swiss Accreditation Service is one of the signatories to the EA  
Multilateral Agreement for the recognition of calibration certificates

Accreditation No.: **SCS 0108**

**Glossary:**

TSL	tissue simulating liquid
ConvF	sensitivity in TSL / NORM x,y,z
N/A	not applicable or not measured

**Calibration is Performed According to the Following Standards:**

- IEEE Std 1528-2013, "IEEE Recommended Practice for Determining the Peak Spatial-Averaged Specific Absorption Rate (SAR) in the Human Head from Wireless Communications Devices: Measurement Techniques", June 2013
- IEC 62209-2, "Procedure to determine the Specific Absorption Rate (SAR) for wireless communication devices used in close proximity to the human body (frequency range of 30 MHz to 6 GHz)", March 2010
- KDB 865664, "SAR Measurement Requirements for 100 MHz to 6 GHz"

**Additional Documentation:**

- DASY4/5 System Handbook

**Methods Applied and Interpretation of Parameters:**

- Measurement Conditions:** Further details are available from the Validation Report at the end of the certificate. All figures stated in the certificate are valid at the frequency indicated.
- Antenna Parameters with TSL:** The dipole is mounted with the spacer to position its feed point exactly below the center marking of the flat phantom section, with the arms oriented parallel to the body axis.
- Feed Point Impedance and Return Loss:** These parameters are measured with the dipole positioned under the liquid filled phantom. The impedance stated is transformed from the measurement at the SMA connector to the feed point. The Return Loss ensures low reflected power. No uncertainty required.
- Electrical Delay:** One-way delay between the SMA connector and the antenna feed point. No uncertainty required.
- SAR measured:** SAR measured at the stated antenna input power.
- SAR normalized:** SAR as measured, normalized to an input power of 1 W at the antenna connector.
- SAR for nominal TSL parameters:** The measured TSL parameters are used to calculate the nominal SAR result.

The reported uncertainty of measurement is stated as the standard uncertainty of measurement multiplied by the coverage factor  $k=2$ , which for a normal distribution corresponds to a coverage probability of approximately 95%.



## Measurement Conditions

DASY system configuration, as far as not given on page 1.

DASY Version	DASY5	V52.8.8
Extrapolation	Advanced Extrapolation	
Phantom	Modular Flat Phantom V5.0	
Distance Dipole Center - TSL	10 mm	with Spacer
Zoom Scan Resolution	dx, dy = 4.0 mm, dz = 1.4 mm	Graded Ratio = 1.4 (Z direction)
Frequency	5250 MHz $\pm$ 1 MHz 5600 MHz $\pm$ 1 MHz 5750 MHz $\pm$ 1 MHz	

## Head TSL parameters at 5250 MHz

The following parameters and calculations were applied.

	Temperature	Permittivity	Conductivity
Nominal Head TSL parameters	22.0 °C	35.9	4.71 mho/m
Measured Head TSL parameters	(22.0 $\pm$ 0.2) °C	34.9 $\pm$ 6 %	4.57 mho/m $\pm$ 6 %
Head TSL temperature change during test	< 0.5 °C	----	----

## SAR result with Head TSL at 5250 MHz

SAR averaged over 1 cm <sup>3</sup> (1 g) of Head TSL	Condition	
SAR measured	100 mW input power	7.98 W/kg
SAR for nominal Head TSL parameters	normalized to 1W	79.3 W/kg $\pm$ 19.9 % (k=2)

SAR averaged over 10 cm <sup>3</sup> (10 g) of Head TSL	condition	
SAR measured	100 mW input power	2.29 W/kg
SAR for nominal Head TSL parameters	normalized to 1W	22.7 W/kg $\pm$ 19.5 % (k=2)

## Head TSL parameters at 5600 MHz

The following parameters and calculations were applied.

	Temperature	Permittivity	Conductivity
Nominal Head TSL parameters	22.0 °C	35.5	5.07 mho/m
Measured Head TSL parameters	(22.0 $\pm$ 0.2) °C	34.4 $\pm$ 6 %	4.92 mho/m $\pm$ 6 %
Head TSL temperature change during test	< 0.5 °C	----	----

## SAR result with Head TSL at 5600 MHz

SAR averaged over 1 cm <sup>3</sup> (1 g) of Head TSL	Condition	
SAR measured	100 mW input power	8.49 W/kg
SAR for nominal Head TSL parameters	normalized to 1W	84.2 W / kg $\pm$ 19.9 % (k=2)

SAR averaged over 10 cm <sup>3</sup> (10 g) of Head TSL	condition	
SAR measured	100 mW input power	2.42 W/kg
SAR for nominal Head TSL parameters	normalized to 1W	24.0 W/kg $\pm$ 19.5 % (k=2)

## Head TSL parameters at 5750 MHz

The following parameters and calculations were applied.

	Temperature	Permittivity	Conductivity
Nominal Head TSL parameters	22.0 °C	35.4	5.22 mho/m
Measured Head TSL parameters	(22.0 ± 0.2) °C	34.2 ± 6 %	5.07 mho/m ± 6 %
Head TSL temperature change during test	< 0.5 °C	----	----

## SAR result with Head TSL at 5750 MHz

SAR averaged over 1 cm <sup>3</sup> (1 g) of Head TSL	Condition	
SAR measured	100 mW input power	8.30 W/kg
SAR for nominal Head TSL parameters	normalized to 1W	<b>82.3 W/kg ± 19.9 % (k=2)</b>

SAR averaged over 10 cm <sup>3</sup> (10 g) of Head TSL	condition	
SAR measured	100 mW input power	2.35 W/kg
SAR for nominal Head TSL parameters	normalized to 1W	<b>23.3 W/kg ± 19.5 % (k=2)</b>

### Body TSL parameters at 5250 MHz

The following parameters and calculations were applied.

	Temperature	Permittivity	Conductivity
Nominal Body TSL parameters	22.0 °C	48.9	5.36 mho/m
Measured Body TSL parameters	(22.0 ± 0.2) °C	48.1 ± 6 %	5.52 mho/m ± 6 %
Body TSL temperature change during test	< 0.5 °C	----	----

### SAR result with Body TSL at 5250 MHz

SAR averaged over 1 cm <sup>3</sup> (1 g) of Body TSL	Condition	
SAR measured	100 mW input power	7.61 W/kg
SAR for nominal Body TSL parameters	normalized to 1W	75.9 W/kg ± 19.9 % (k=2)

SAR averaged over 10 cm <sup>3</sup> (10 g) of Body TSL	condition	
SAR measured	100 mW input power	2.14 W/kg
SAR for nominal Body TSL parameters	normalized to 1W	21.3 W/kg ± 19.5 % (k=2)

### Body TSL parameters at 5600 MHz

The following parameters and calculations were applied.

	Temperature	Permittivity	Conductivity
Nominal Body TSL parameters	22.0 °C	48.5	5.77 mho/m
Measured Body TSL parameters	(22.0 ± 0.2) °C	47.5 ± 6 %	5.99 mho/m ± 6 %
Body TSL temperature change during test	< 0.5 °C	----	----

### SAR result with Body TSL at 5600 MHz

SAR averaged over 1 cm <sup>3</sup> (1 g) of Body TSL	Condition	
SAR measured	100 mW input power	7.91 W/kg
SAR for nominal Body TSL parameters	normalized to 1W	78.9 W/kg ± 19.9 % (k=2)

SAR averaged over 10 cm <sup>3</sup> (10 g) of Body TSL	condition	
SAR measured	100 mW input power	2.22 W/kg
SAR for nominal Body TSL parameters	normalized to 1W	22.1 W/kg ± 19.5 % (k=2)

### Body TSL parameters at 5750 MHz

The following parameters and calculations were applied.

	Temperature	Permittivity	Conductivity
Nominal Body TSL parameters	22.0 °C	48.3	5.94 mho/m
Measured Body TSL parameters	(22.0 ± 0.2) °C	47.2 ± 6 %	6.21 mho/m ± 6 %
Body TSL temperature change during test	< 0.5 °C	----	----

### SAR result with Body TSL at 5750 MHz

SAR averaged over 1 cm <sup>3</sup> (1 g) of Body TSL	Condition	
SAR measured	100 mW input power	7.65 W/kg
SAR for nominal Body TSL parameters	normalized to 1W	<b>76.3 W/kg ± 19.9 % (k=2)</b>

SAR averaged over 10 cm <sup>3</sup> (10 g) of Body TSL	condition	
SAR measured	100 mW input power	2.14 W/kg
SAR for nominal Body TSL parameters	normalized to 1W	<b>21.3 W/kg ± 19.5 % (k=2)</b>

**Appendix (Additional assessments outside the scope of SCS 0108)**

**Antenna Parameters with Head TSL at 5250 MHz**

Impedance, transformed to feed point	51.6 $\Omega$ - 5.7 j $\Omega$
Return Loss	- 24.7 dB

**Antenna Parameters with Head TSL at 5600 MHz**

Impedance, transformed to feed point	55.9 $\Omega$ - 0.7 j $\Omega$
Return Loss	- 25.1 dB

**Antenna Parameters with Head TSL at 5750 MHz**

Impedance, transformed to feed point	56.7 $\Omega$ + 1.2 j $\Omega$
Return Loss	- 23.9 dB

**Antenna Parameters with Body TSL at 5250 MHz**

Impedance, transformed to feed point	51.8 $\Omega$ - 3.8 j $\Omega$
Return Loss	- 27.7 dB

**Antenna Parameters with Body TSL at 5600 MHz**

Impedance, transformed to feed point	58.2 $\Omega$ + 1.4 j $\Omega$
Return Loss	- 22.3 dB

**Antenna Parameters with Body TSL at 5750 MHz**

Impedance, transformed to feed point	57.3 $\Omega$ + 3.7 j $\Omega$
Return Loss	- 22.4 dB

## General Antenna Parameters and Design

Electrical Delay (one direction)	1.205 ns
----------------------------------	----------

After long term use with 100W radiated power, only a slight warming of the dipole near the feedpoint can be measured.

The dipole is made of standard semirigid coaxial cable. The center conductor of the feeding line is directly connected to the second arm of the dipole. The antenna is therefore short-circuited for DC-signals. On some of the dipoles, small end caps are added to the dipole arms in order to improve matching when loaded according to the position as explained in the "Measurement Conditions" paragraph. The SAR data are not affected by this change. The overall dipole length is still according to the Standard.

No excessive force must be applied to the dipole arms, because they might bend or the soldered connections near the feedpoint may be damaged.

## Additional EUT Data

Manufactured by	SPEAG
Manufactured on	September 08, 2011

## DASY5 Validation Report for Head TSL

Date: 08.03.2017

Test Laboratory: SPEAG, Zurich, Switzerland

**DUT: Dipole D5GHzV2; Type: D5GHzV2; Serial: D5GHzV2 - SN:1123**

Communication System: UID 0 - CW; Frequency: 5250 MHz, Frequency: 5600 MHz, Frequency: 5750 MHz  
Medium parameters used:  $f = 5250$  MHz;  $\sigma = 4.57$  S/m;  $\epsilon_r = 34.9$ ;  $\rho = 1000$  kg/m<sup>3</sup>, Medium parameters used:  $f = 5600$  MHz;  $\sigma = 4.92$  S/m;  $\epsilon_r = 34.4$ ;  $\rho = 1000$  kg/m<sup>3</sup>, Medium parameters used:  $f = 5750$  MHz;  $\sigma = 5.07$  S/m;  $\epsilon_r = 34.2$ ;  $\rho = 1000$  kg/m<sup>3</sup>

Phantom section: Flat Section

Measurement Standard: DASY5 (IEEE/IEC/ANSI C63.19-2011)

DASY52 Configuration:

- Probe: EX3DV4 - SN3503; ConvF(5.58, 5.58, 5.58); Calibrated: 31.12.2016, ConvF(5.09, 5.09, 5.09); Calibrated: 31.12.2016, ConvF(5.02, 5.02, 5.02); Calibrated: 31.12.2016;
- Sensor-Surface: 1.4mm (Mechanical Surface Detection)
- Electronics: DAE4 Sn601; Calibrated: 04.01.2017
- Phantom: Flat Phantom 5.0 (front); Type: QD 000 P50 AA; Serial: 1001
- DASY52 52.8.8(1258); SEMCAD X 14.6.10(7372)

### **Dipole Calibration for Head Tissue/Pin=100mW, dist=10mm, f=5250 MHz/Zoom Scan,**

**dist=1.4mm (8x8x7)/Cube 0:** Measurement grid: dx=4mm, dy=4mm, dz=1.4mm

Reference Value = 71.62 V/m; Power Drift = -0.03 dB

Peak SAR (extrapolated) = 29.9 W/kg

**SAR(1 g) = 7.98 W/kg; SAR(10 g) = 2.29 W/kg**

Maximum value of SAR (measured) = 18.3 W/kg

### **Dipole Calibration for Head Tissue/Pin=100mW, dist=10mm, f=5600 MHz/Zoom Scan,**

**dist=1.4mm (8x8x7)/Cube 0:** Measurement grid: dx=4mm, dy=4mm, dz=1.4mm

Reference Value = 71.47 V/m; Power Drift = -0.08 dB

Peak SAR (extrapolated) = 34.1 W/kg

**SAR(1 g) = 8.49 W/kg; SAR(10 g) = 2.42 W/kg**

Maximum value of SAR (measured) = 19.8 W/kg

### **Dipole Calibration for Head Tissue/Pin=100mW, dist=10mm, f=5750 MHz/Zoom Scan,**

**dist=1.4mm (8x8x7)/Cube 0:** Measurement grid: dx=4mm, dy=4mm, dz=1.4mm

Reference Value = 70.34 V/m; Power Drift = -0.05 dB

Peak SAR (extrapolated) = 34.6 W/kg

**SAR(1 g) = 8.3 W/kg; SAR(10 g) = 2.35 W/kg**

Maximum value of SAR (measured) = 19.6 W/kg

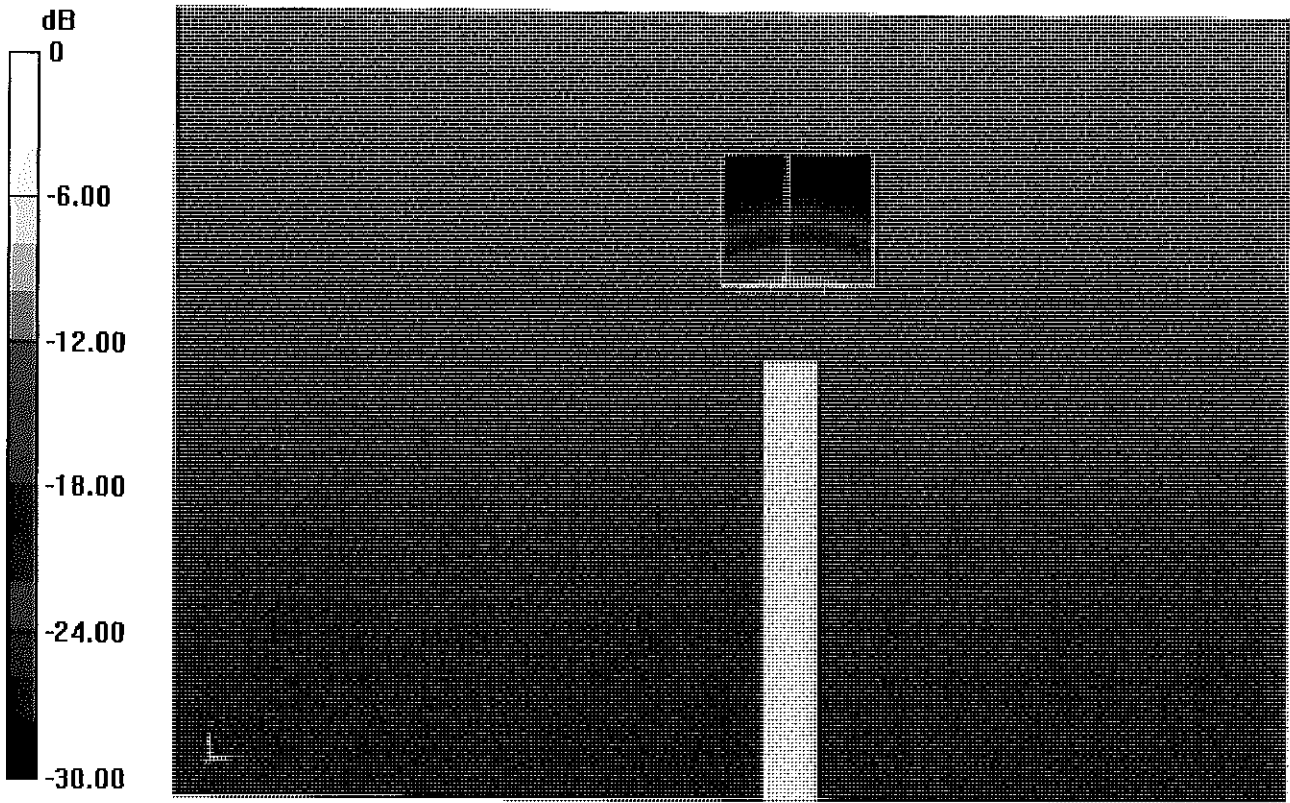

0 dB = 18.3 W/kg = 12.62 dBW/kg



# Impedance Measurement Plot for Head TSL

7 Mar 2017 16:46:55

CH1 S11 1 U FS 2: 51.596  $\Omega$  -5.7227  $\Omega$  5.2973 pF 5 250.000 000 MHz

\*  
Del  
Cor  
Avg  
16  
H1d

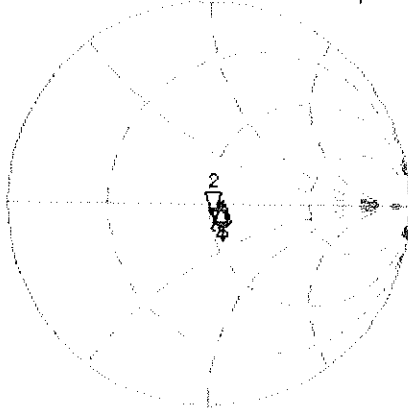

CH1 Markers  
4: 55.865  $\Omega$   
-748.05 m $\Omega$   
5.60000 GHz  
5: 56.672  $\Omega$   
1.1895  $\Omega$   
5.75000 GHz

CH2 S11 LOG 5 dB/REF -20 dB 2: -24.673 dB 5 250.000 000 MHz

Cor  
Avg  
16  
H1d

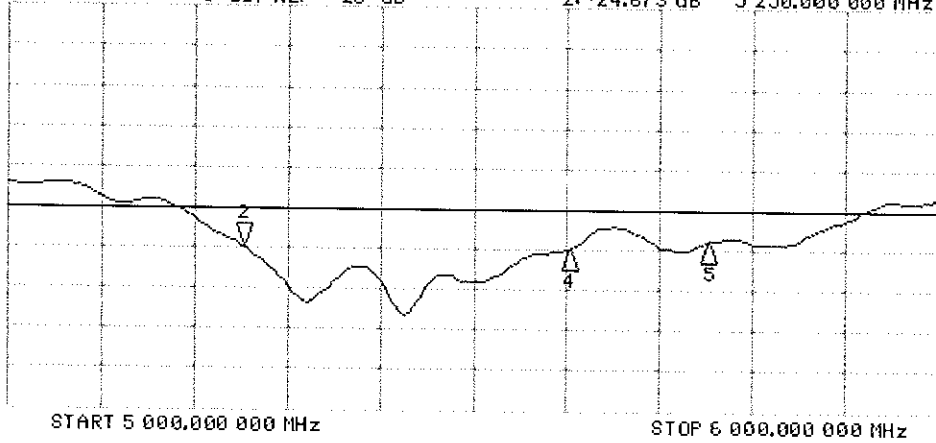

CH2 Markers  
4: -25.063 dB  
5.60000 GHz  
5: -23.938 dB  
5.75000 GHz

## DASY5 Validation Report for Body TSL

Date: 09.03.2017

Test Laboratory: SPEAG, Zurich, Switzerland

**DUT: Dipole D5GHzV2; Type: D5GHzV2; Serial: D5GHzV2 - SN:1123**

Communication System: UID 0 - CW; Frequency: 5250 MHz, Frequency: 5600 MHz, Frequency: 5750 MHz  
Medium parameters used:  $f = 5250$  MHz;  $\sigma = 5.52$  S/m;  $\epsilon_r = 48.1$ ;  $\rho = 1000$  kg/m<sup>3</sup>, Medium parameters used:  $f = 5600$  MHz;  $\sigma = 5.99$  S/m;  $\epsilon_r = 47.5$ ;  $\rho = 1000$  kg/m<sup>3</sup>, Medium parameters used:  $f = 5750$  MHz;  $\sigma = 6.21$  S/m;  $\epsilon_r = 47.2$ ;  $\rho = 1000$  kg/m<sup>3</sup>

Phantom section: Flat Section

Measurement Standard: DASY5 (IEEE/IEC/ANSI C63.19-2011)

DASY52 Configuration:

- Probe: EX3DV4 - SN3503; ConvF(5.14, 5.14, 5.14); Calibrated: 31.12.2016, ConvF(4.57, 4.57, 4.57); Calibrated: 31.12.2016, ConvF(4.52, 4.52, 4.52); Calibrated: 31.12.2016;
- Sensor-Surface: 1.4mm (Mechanical Surface Detection)
- Electronics: DAE4 Sn601; Calibrated: 04.01.2017
- Phantom: Flat Phantom 5.0 (back); Type: QD 000 P50 AA; Serial: 1002
- DASY52 52.8.8(1258); SEMCAD X 14.6.10(7372)

**Dipole Calibration for Body Tissue/Pin=100mW, dist=10mm, f=5250MHz/Zoom Scan, dist=1.4mm (8x8x7)/Cube 0:** Measurement grid: dx=4mm, dy=4mm, dz=1.4mm

Reference Value = 64.40 V/m; Power Drift = -0.06 dB

Peak SAR (extrapolated) = 29.1 W/kg

**SAR(1 g) = 7.61 W/kg; SAR(10 g) = 2.14 W/kg**

Maximum value of SAR (measured) = 17.5 W/kg

**Dipole Calibration for Body Tissue/Pin=100mW, dist=10mm, f=5600 MHz/Zoom Scan, dist=1.4mm (8x8x7)/Cube 0:** Measurement grid: dx=4mm, dy=4mm, dz=1.4mm

Reference Value = 63.91 V/m; Power Drift = -0.03 dB

Peak SAR (extrapolated) = 33.2 W/kg

**SAR(1 g) = 7.91 W/kg; SAR(10 g) = 2.22 W/kg**

Maximum value of SAR (measured) = 18.7 W/kg

**Dipole Calibration for Body Tissue/Pin=100mW, dist=10mm, f=5750 MHz/Zoom Scan, dist=1.4mm (8x8x7)/Cube 0:** Measurement grid: dx=4mm, dy=4mm, dz=1.4mm

Reference Value = 63.25 V/m; Power Drift = -0.07 dB

Peak SAR (extrapolated) = 33.4 W/kg

**SAR(1 g) = 7.65 W/kg; SAR(10 g) = 2.14 W/kg**

Maximum value of SAR (measured) = 18.3 W/kg

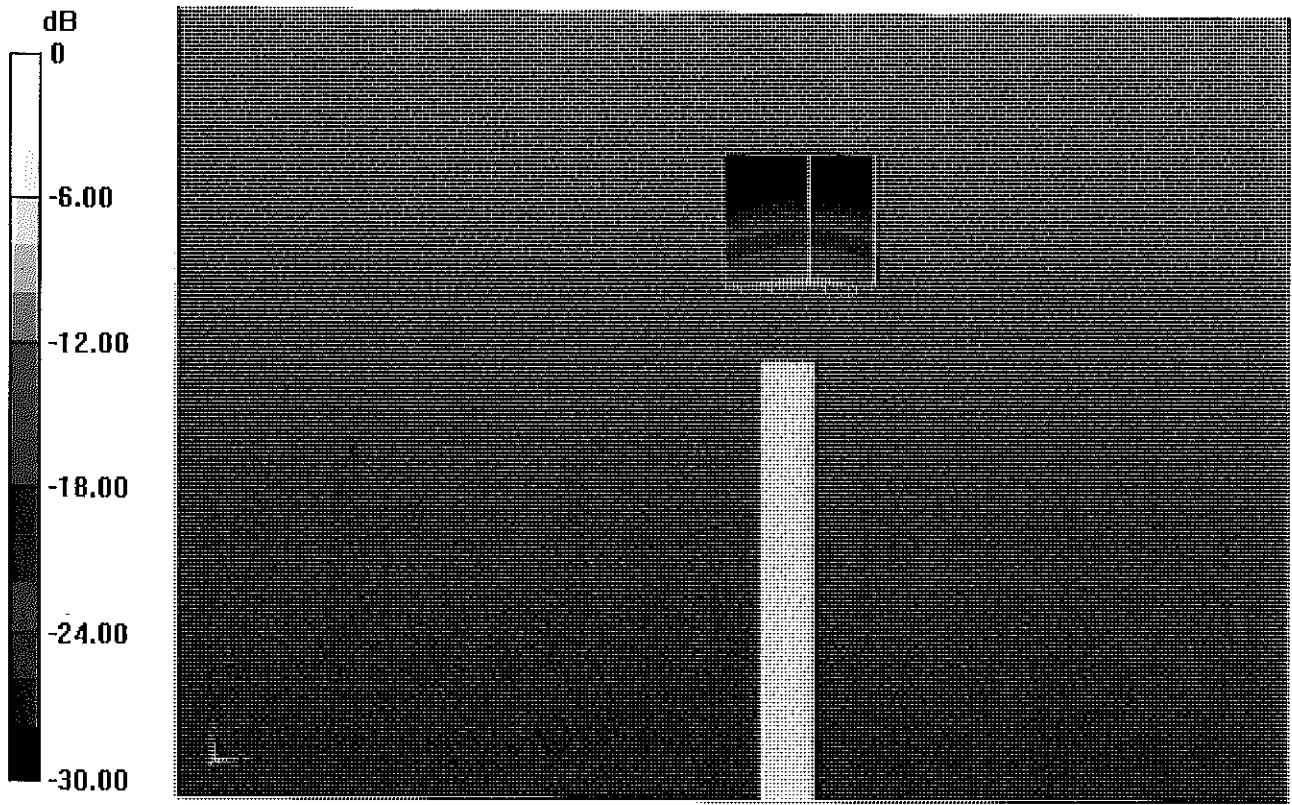

0 dB = 17.5 W/kg = 12.43 dBW/kg

# Impedance Measurement Plot for Body TSL

9 Mar 2017 16:41:27

CH1 S11 1 U FS

1: 51.783  $\Omega$  -3.8203  $\Omega$  7.9353 pF

5 250.000 000 MHz

\*  
De l  
Cor

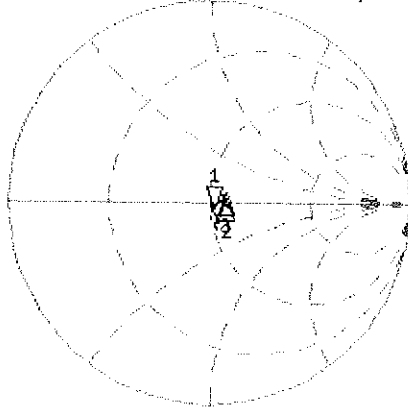

CH1 Markers

2: 58.230  $\Omega$   
1.4043  $\Omega$   
5.60000 GHz  
3: 57.275  $\Omega$   
3.6953  $\Omega$   
5.75000 GHz

Avg  
16

H1 d

CH2 S11 LOG

5 dB/REF -20 dB

1: -27.665 dB 5 250.000 000 MHz

Cor

Avg  
16

H1 d

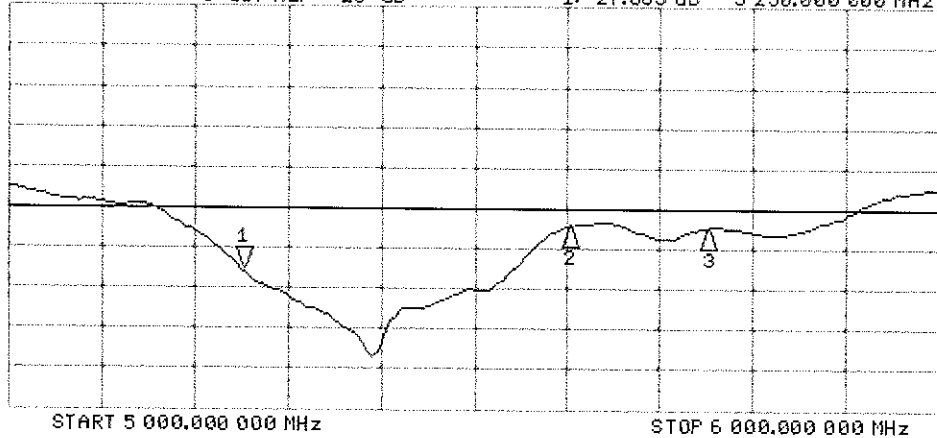

CH2 Markers

2: -22.256 dB  
5.60000 GHz  
3: -22.380 dB  
5.75000 GHz



Accredited by the Swiss Accreditation Service (SAS)  
The Swiss Accreditation Service is one of the signatories to the EA  
Multilateral Agreement for the recognition of calibration certificates

Accreditation No.: **SCS 0108**

Client **PC Test**

Certificate No: **D2600V2-1071\_Sep16**

## CALIBRATION CERTIFICATE

Object **D2600V2 - SN:1071**

Calibration procedure(s) **QA CAL-05.v9  
Calibration procedure for dipole validation kits above 700 MHz**

*BNV*  
*09-28-2016*

Calibration date: **September 13, 2016**

This calibration certificate documents the traceability to national standards, which realize the physical units of measurements (SI).  
The measurements and the uncertainties with confidence probability are given on the following pages and are part of the certificate.

All calibrations have been conducted in the closed laboratory facility: environment temperature ( $22 \pm 3$ )°C and humidity < 70%.

Calibration Equipment used (M&TE critical for calibration)

Primary Standards	ID #	Cal Date (Certificate No.)	Scheduled Calibration
Power meter NRP	SN: 104778	06-Apr-16 (No. 217-02288/02289)	Apr-17
Power sensor NRP-Z91	SN: 103244	06-Apr-16 (No. 217-02288)	Apr-17
Power sensor NRP-Z91	SN: 103245	06-Apr-16 (No. 217-02289)	Apr-17
Reference 20 dB Attenuator	SN: 5058 (20k)	05-Apr-16 (No. 217-02292)	Apr-17
Type-N mismatch combination	SN: 5047.2 / 06327	05-Apr-16 (No. 217-02295)	Apr-17
Reference Probe EX3DV4	SN: 7349	15-Jun-16 (No. EX3-7349_Jun16)	Jun-17
DAE4	SN: 601	30-Dec-15 (No. DAE4-601_Dec15)	Dec-16
Secondary Standards	ID #	Check Date (in house)	Scheduled Check
Power meter EPM-442A	SN: GB37480704	07-Oct-15 (No. 217-02222)	In house check: Oct-16
Power sensor HP 8481A	SN: US37292783	07-Oct-15 (No. 217-02222)	In house check: Oct-16
Power sensor HP 8481A	SN: MY41092317	07-Oct-15 (No. 217-02223)	In house check: Oct-16
RF generator R&S SMT-06	SN: 100972	15-Jun-15 (in house check Jun-15)	In house check: Oct-16
Network Analyzer HP 8753E	SN: US37390585	18-Oct-01 (in house check Oct-15)	In house check: Oct-16

Calibrated by: **Jeton Kastrati**      Function: **Laboratory Technician**

Approved by: **Katja Pokovic**      Technical Manager

Signature  
*[Handwritten Signature]*  
*[Handwritten Signature]*

Issued: September 13, 2016

This calibration certificate shall not be reproduced except in full without written approval of the laboratory.



Accredited by the Swiss Accreditation Service (SAS)  
The Swiss Accreditation Service is one of the signatories to the EA  
Multilateral Agreement for the recognition of calibration certificates

Accreditation No.: **SCS 0108**

### Glossary:

TSL	tissue simulating liquid
ConvF	sensitivity in TSL / NORM x,y,z
N/A	not applicable or not measured

### Calibration is Performed According to the Following Standards:

- IEEE Std 1528-2013, "IEEE Recommended Practice for Determining the Peak Spatial-Averaged Specific Absorption Rate (SAR) in the Human Head from Wireless Communications Devices: Measurement Techniques", June 2013
- IEC 62209-1, "Procedure to measure the Specific Absorption Rate (SAR) for hand-held devices used in close proximity to the ear (frequency range of 300 MHz to 3 GHz)", February 2005
- IEC 62209-2, "Procedure to determine the Specific Absorption Rate (SAR) for wireless communication devices used in close proximity to the human body (frequency range of 30 MHz to 6 GHz)", March 2010
- KDB 865664, "SAR Measurement Requirements for 100 MHz to 6 GHz"

### Additional Documentation:

- DASY4/5 System Handbook

### Methods Applied and Interpretation of Parameters:

- Measurement Conditions:** Further details are available from the Validation Report at the end of the certificate. All figures stated in the certificate are valid at the frequency indicated.
- Antenna Parameters with TSL:** The dipole is mounted with the spacer to position its feed point exactly below the center marking of the flat phantom section, with the arms oriented parallel to the body axis.
- Feed Point Impedance and Return Loss:** These parameters are measured with the dipole positioned under the liquid filled phantom. The impedance stated is transformed from the measurement at the SMA connector to the feed point. The Return Loss ensures low reflected power. No uncertainty required.
- Electrical Delay:** One-way delay between the SMA connector and the antenna feed point. No uncertainty required.
- SAR measured:** SAR measured at the stated antenna input power.
- SAR normalized:** SAR as measured, normalized to an input power of 1 W at the antenna connector.
- SAR for nominal TSL parameters:** The measured TSL parameters are used to calculate the nominal SAR result.

The reported uncertainty of measurement is stated as the standard uncertainty of measurement multiplied by the coverage factor  $k=2$ , which for a normal distribution corresponds to a coverage probability of approximately 95%.

## Measurement Conditions

DASY system configuration, as far as not given on page 1.

DASY Version	DASY5	V52.8.8
Extrapolation	Advanced Extrapolation	
Phantom	Modular Flat Phantom	
Distance Dipole Center - TSL	10 mm	with Spacer
Zoom Scan Resolution	dx, dy, dz = 5 mm	
Frequency	2600 MHz $\pm$ 1 MHz	

## Head TSL parameters

The following parameters and calculations were applied.

	Temperature	Permittivity	Conductivity
Nominal Head TSL parameters	22.0 °C	39.0	1.96 mho/m
Measured Head TSL parameters	(22.0 $\pm$ 0.2) °C	37.3 $\pm$ 6 %	2.05 mho/m $\pm$ 6 %
Head TSL temperature change during test	< 0.5 °C	----	----

## SAR result with Head TSL

SAR averaged over 1 cm <sup>3</sup> (1 g) of Head TSL	Condition	
SAR measured	250 mW input power	14.5 W/kg
SAR for nominal Head TSL parameters	normalized to 1W	56.3 W/kg $\pm$ 17.0 % (k=2)

SAR averaged over 10 cm <sup>3</sup> (10 g) of Head TSL	condition	
SAR measured	250 mW input power	6.45 W/kg
SAR for nominal Head TSL parameters	normalized to 1W	25.3 W/kg $\pm$ 16.5 % (k=2)

## Body TSL parameters

The following parameters and calculations were applied.

	Temperature	Permittivity	Conductivity
Nominal Body TSL parameters	22.0 °C	52.5	2.16 mho/m
Measured Body TSL parameters	(22.0 $\pm$ 0.2) °C	51.1 $\pm$ 6 %	2.22 mho/m $\pm$ 6 %
Body TSL temperature change during test	< 0.5 °C	----	----

## SAR result with Body TSL

SAR averaged over 1 cm <sup>3</sup> (1 g) of Body TSL	Condition	
SAR measured	250 mW input power	13.8 W/kg
SAR for nominal Body TSL parameters	normalized to 1W	54.2 W/kg $\pm$ 17.0 % (k=2)

SAR averaged over 10 cm <sup>3</sup> (10 g) of Body TSL	condition	
SAR measured	250 mW input power	6.20 W/kg
SAR for nominal Body TSL parameters	normalized to 1W	24.5 W/kg $\pm$ 16.5 % (k=2)

## Appendix (Additional assessments outside the scope of SCS 0108)

### Antenna Parameters with Head TSL

Impedance, transformed to feed point	49.9 $\Omega$ - 6.7 j $\Omega$
Return Loss	- 23.5 dB

### Antenna Parameters with Body TSL

Impedance, transformed to feed point	46.1 $\Omega$ - 2.1 j $\Omega$
Return Loss	- 26.7 dB

### General Antenna Parameters and Design

Electrical Delay (one direction)	1.153 ns
----------------------------------	----------

After long term use with 100W radiated power, only a slight warming of the dipole near the feedpoint can be measured.

The dipole is made of standard semirigid coaxial cable. The center conductor of the feeding line is directly connected to the second arm of the dipole. The antenna is therefore short-circuited for DC-signals. On some of the dipoles, small end caps are added to the dipole arms in order to improve matching when loaded according to the position as explained in the "Measurement Conditions" paragraph. The SAR data are not affected by this change. The overall dipole length is still according to the Standard.

No excessive force must be applied to the dipole arms, because they might bend or the soldered connections near the feedpoint may be damaged.

### Additional EUT Data

Manufactured by	SPEAG
Manufactured on	July 17, 2013



## DASY5 Validation Report for Head TSL

Date: 13.09.2016

Test Laboratory: SPEAG, Zurich, Switzerland

**DUT: Dipole 2600 MHz; Type: D2600V2; Serial: D2600V2 - SN:1071**

Communication System: UID 0 - CW; Frequency: 2600 MHz

Medium parameters used:  $f = 2600$  MHz;  $\sigma = 2.05$  S/m;  $\epsilon_r = 37.3$ ;  $\rho = 1000$  kg/m<sup>3</sup>

Phantom section: Flat Section

Measurement Standard: DASY5 (IEEE/IEC/ANSI C63.19-2011)

DASY52 Configuration:

- Probe: EX3DV4 - SN7349; ConvF(7.56, 7.56, 7.56); Calibrated: 15.06.2016;
- Sensor-Surface: 1.4mm (Mechanical Surface Detection)
- Electronics: DAE4 Sn601; Calibrated: 30.12.2015
- Phantom: Flat Phantom 5.0 (front); Type: QD000P50AA; Serial: 1001
- DASY52 52.8.8(1258); SEMCAD X 14.6.10(7372)

### **Dipole Calibration for Head Tissue/Pin=250 mW, d=10mm/Zoom Scan (7x7x7)/Cube 0:**

Measurement grid: dx=5mm, dy=5mm, dz=5mm

Reference Value = 115.1 V/m; Power Drift = -0.02 dB

Peak SAR (extrapolated) = 30.4 W/kg

**SAR(1 g) = 14.5 W/kg; SAR(10 g) = 6.45 W/kg**

Maximum value of SAR (measured) = 24.6 W/kg

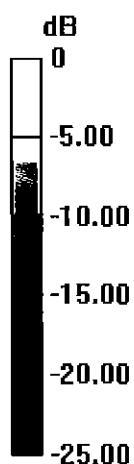

0 dB = 24.6 W/kg = 13.91 dBW/kg

# Impedance Measurement Plot for Head TSL

12 Sep 2016 13:13:44

CH1 S11 1 U FS 4: 49.902  $\Omega$  -6.6523  $\Omega$  9.2018 pF 2 600.000 000 MHz

\*  
De 1

CA

Avg  
16

H1 d

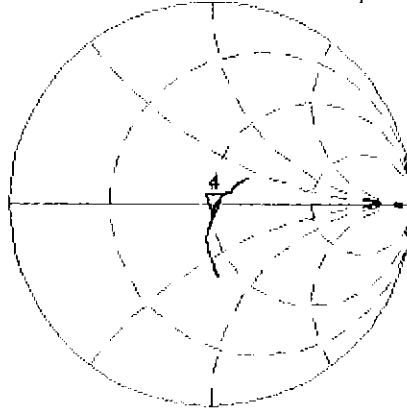

CH2 S11 LOG 5 dB/REF -20 dB 4: -23.548 dB 2 600.000 000 MHz

CA

Avg  
16

H1 d

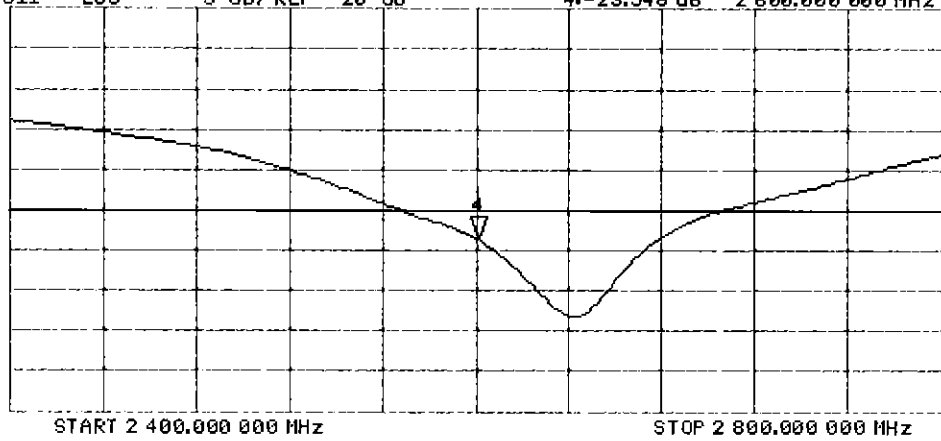

# DASY5 Validation Report for Body TSL

Date: 13.09.2016

Test Laboratory: SPEAG, Zurich, Switzerland

**DUT: Dipole 2600 MHz; Type: D2600V2; Serial: D2600V2 - SN:1071**

Communication System: UID 0 - CW; Frequency: 2600 MHz

Medium parameters used:  $f = 2600$  MHz;  $\sigma = 2.22$  S/m;  $\epsilon_r = 51.1$ ;  $\rho = 1000$  kg/m<sup>3</sup>

Phantom section: Flat Section

Measurement Standard: DASY5 (IEEE/IEC/ANSI C63.19-2011)

DASY52 Configuration:

- Probe: EX3DV4 - SN7349; ConvF(7.48, 7.48, 7.48); Calibrated: 15.06.2016;
- Sensor-Surface: 1.4mm (Mechanical Surface Detection)
- Electronics: DAE4 Sn601; Calibrated: 30.12.2015
- Phantom: Flat Phantom 5.0 (back); Type: QD000P50AA; Serial: 1002
- DASY52 52.8.8(1258); SEMCAD X 14.6.10(7372)

## Dipole Calibration for Body Tissue/Pin=250 mW, d=10mm/Zoom Scan (7x7x7)/Cube 0:

Measurement grid: dx=5mm, dy=5mm, dz=5mm

Reference Value = 107.7 V/m; Power Drift = -0.03 dB

Peak SAR (extrapolated) = 28.3 W/kg

**SAR(1 g) = 13.8 W/kg; SAR(10 g) = 6.2 W/kg**

Maximum value of SAR (measured) = 23.3 W/kg



0 dB = 23.3 W/kg = 13.67 dBW/kg

# Impedance Measurement Plot for Body TSL

12 Sep 2016 13:13:09

CH1 S11 1 U FS

4: 46.078  $\Omega$  -2.0762  $\Omega$  29.484 pF

2 600.000 000 MHz

\*

De l

Ca

Avg  
16

H1 d

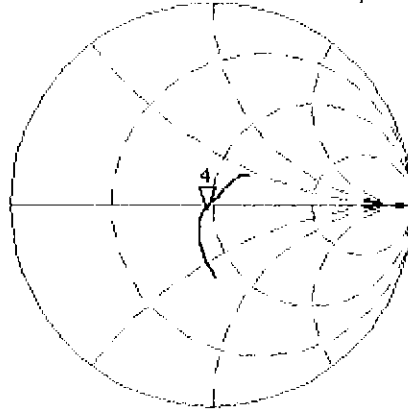

CH2 S11 LOG

5 dB/REF -20 dB

4:-26.721 dB 2 600.000 000 MHz

Ca

Avg  
16

H1 d

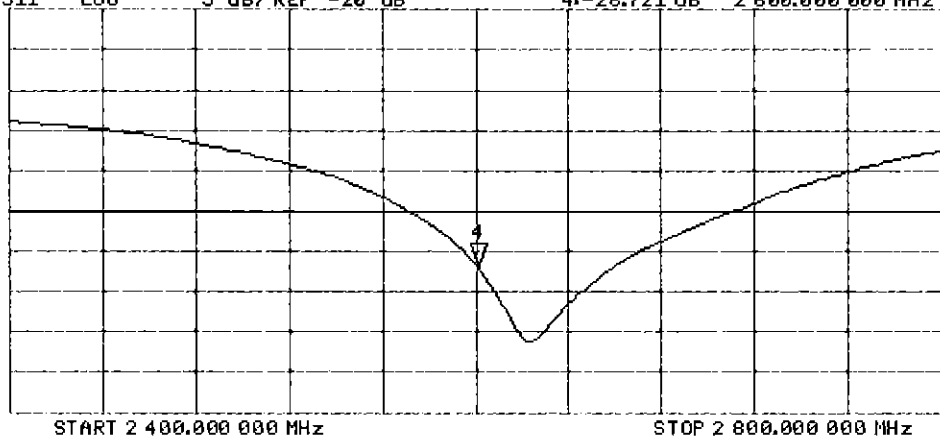



Accredited by the Swiss Accreditation Service (SAS)  
The Swiss Accreditation Service is one of the signatories to the EA  
Multilateral Agreement for the recognition of calibration certificates

Accreditation No.: **SCS 0108**

Client **PC Test**

Certificate No: **ES3-3209\_Mar17**

## CALIBRATION CERTIFICATE

Object **ES3DV3 - SN:3209**

Calibration procedure(s) **QA CAL-01.v9, QA CAL-23.v5, QA CAL-25.v6  
Calibration procedure for dosimetric E-field probes**

*BNW  
03-27-2017*

Calibration date: **March 14, 2017**

This calibration certificate documents the traceability to national standards, which realize the physical units of measurements (SI).  
The measurements and the uncertainties with confidence probability are given on the following pages and are part of the certificate.

All calibrations have been conducted in the closed laboratory facility: environment temperature (22 ± 3)°C and humidity < 70%.

Calibration Equipment used (M&TE critical for calibration)

Primary Standards	ID	Cal Date (Certificate No.)	Scheduled Calibration
Power meter NRP	SN: 104778	06-Apr-16 (No. 217-02288/02289)	Apr-17
Power sensor NRP-Z91	SN: 103244	06-Apr-16 (No. 217-02288)	Apr-17
Power sensor NRP-Z91	SN: 103245	06-Apr-16 (No. 217-02289)	Apr-17
Reference 20 dB Attenuator	SN: S5277 (20x)	05-Apr-16 (No. 217-02293)	Apr-17
Reference Probe ES3DV2	SN: 3013	31-Dec-16 (No. ES3-3013_Dec16)	Dec-17
DAE4	SN: 660	7-Dec-16 (No. DAE4-660_Dec16)	Dec-17
Secondary Standards	ID	Check Date (in house)	Scheduled Check
Power meter E4419B	SN: GB41293874	06-Apr-16 (in house check Jun-16)	In house check: Jun-18
Power sensor E4412A	SN: MY41498087	06-Apr-16 (in house check Jun-16)	In house check: Jun-18
Power sensor E4412A	SN: 000110210	06-Apr-16 (in house check Jun-16)	In house check: Jun-18
RF generator HP 8648C	SN: US3642U01700	04-Aug-99 (in house check Jun-16)	In house check: Jun-18
Network Analyzer HP 8753E	SN: US37390585	18-Oct-01 (in house check Oct-16)	In house check: Oct-17

	Name	Function	Signature
Calibrated by:	<b>Jeton Kastrati</b>	<b>Laboratory Technician</b>	
Approved by:	<b>Katja Pokovic</b>	<b>Technical Manager</b>	
			Issued: March 16, 2017
This calibration certificate shall not be reproduced except in full without written approval of the laboratory.			



Accredited by the Swiss Accreditation Service (SAS)

Accreditation No.: **SCS 0108**

The Swiss Accreditation Service is one of the signatories to the EA Multilateral Agreement for the recognition of calibration certificates

**Glossary:**

TSL	tissue simulating liquid
NORM <sub>x,y,z</sub>	sensitivity in free space
ConvF	sensitivity in TSL / NORM <sub>x,y,z</sub>
DCP	diode compression point
CF	crest factor (1/duty_cycle) of the RF signal
A, B, C, D	modulation dependent linearization parameters
Polarization $\phi$	$\phi$ rotation around probe axis
Polarization $\vartheta$	$\vartheta$ rotation around an axis that is in the plane normal to probe axis (at measurement center), i.e., $\vartheta = 0$ is normal to probe axis
Connector Angle	information used in DASY system to align probe sensor X to the robot coordinate system

**Calibration is Performed According to the Following Standards:**

- a) IEEE Std 1528-2013, "IEEE Recommended Practice for Determining the Peak Spatial-Averaged Specific Absorption Rate (SAR) in the Human Head from Wireless Communications Devices: Measurement Techniques", June 2013
- b) IEC 62209-1, "Procedure to measure the Specific Absorption Rate (SAR) for hand-held devices used in close proximity to the ear (frequency range of 300 MHz to 3 GHz)", February 2005
- c) IEC 62209-2, "Procedure to determine the Specific Absorption Rate (SAR) for wireless communication devices used in close proximity to the human body (frequency range of 30 MHz to 6 GHz)", March 2010
- d) KDB 865664, "SAR Measurement Requirements for 100 MHz to 6 GHz"

**Methods Applied and Interpretation of Parameters:**

- *NORM<sub>x,y,z</sub>*: Assessed for E-field polarization  $\vartheta = 0$  ( $f \leq 900$  MHz in TEM-cell;  $f > 1800$  MHz: R22 waveguide). *NORM<sub>x,y,z</sub>* are only intermediate values, i.e., the uncertainties of *NORM<sub>x,y,z</sub>* does not affect the  $E^2$ -field uncertainty inside TSL (see below *ConvF*).
- *NORM(f)<sub>x,y,z</sub>* = *NORM<sub>x,y,z</sub>* \* *frequency\_response* (see Frequency Response Chart). This linearization is implemented in DASY4 software versions later than 4.2. The uncertainty of the frequency response is included in the stated uncertainty of *ConvF*.
- *DCP<sub>x,y,z</sub>*: DCP are numerical linearization parameters assessed based on the data of power sweep with CW signal (no uncertainty required). DCP does not depend on frequency nor media.
- *PAR*: PAR is the Peak to Average Ratio that is not calibrated but determined based on the signal characteristics
- *A<sub>x,y,z</sub>*; *B<sub>x,y,z</sub>*; *C<sub>x,y,z</sub>*; *D<sub>x,y,z</sub>*; *VR<sub>x,y,z</sub>*; *A, B, C, D* are numerical linearization parameters assessed based on the data of power sweep for specific modulation signal. The parameters do not depend on frequency nor media. *VR* is the maximum calibration range expressed in RMS voltage across the diode.
- *ConvF* and *Boundary Effect Parameters*: Assessed in flat phantom using E-field (or Temperature Transfer Standard for  $f \leq 800$  MHz) and inside waveguide using analytical field distributions based on power measurements for  $f > 800$  MHz. The same setups are used for assessment of the parameters applied for boundary compensation (alpha, depth) of which typical uncertainty values are given. These parameters are used in DASY4 software to improve probe accuracy close to the boundary. The sensitivity in TSL corresponds to *NORM<sub>x,y,z</sub>* \* *ConvF* whereby the uncertainty corresponds to that given for *ConvF*. A frequency dependent *ConvF* is used in DASY version 4.4 and higher which allows extending the validity from  $\pm 50$  MHz to  $\pm 100$  MHz.
- *Spherical isotropy (3D deviation from isotropy)*: in a field of low gradients realized using a flat phantom exposed by a patch antenna.
- *Sensor Offset*: The sensor offset corresponds to the offset of virtual measurement center from the probe tip (on probe axis). No tolerance required.
- *Connector Angle*: The angle is assessed using the information gained by determining the *NORM<sub>x</sub>* (no uncertainty required).

# Probe ES3DV3

## SN:3209

Manufactured: October 14, 2008  
Calibrated: March 14, 2017

Calibrated for DASY/EASY Systems  
(Note: non-compatible with DASY2 system!)

## DASY/EASY - Parameters of Probe: ES3DV3 - SN:3209

### Basic Calibration Parameters

	Sensor X	Sensor Y	Sensor Z	Unc (k=2)
Norm ( $\mu\text{V}/(\text{V}/\text{m})^2$ ) <sup>A</sup>	1.31	1.28	1.10	$\pm 10.1 \%$
DCP (mV) <sup>B</sup>	98.7	100.9	101.0	

### Modulation Calibration Parameters

UID	Communication System Name		A dB	B dB $\sqrt{\mu\text{V}}$	C	D dB	VR mV	Unc <sup>E</sup> (k=2)
0	CW	X	0.0	0.0	1.0	0.00	185.7	$\pm 3.5 \%$
		Y	0.0	0.0	1.0		188.4	
		Z	0.0	0.0	1.0		174.0	

Note: For details on UID parameters see Appendix.

### Sensor Model Parameters

	C1 fF	C2 fF	$\alpha$ V <sup>-1</sup>	T1 ms.V <sup>-2</sup>	T2 ms.V <sup>-1</sup>	T3 ms	T4 V <sup>-2</sup>	T5 V <sup>-1</sup>	T6
X	55.02	400.2	36.4	24.81	1.139	5.1	1.332	0.294	1.012
Y	53.76	389.5	36.01	25.47	1.401	5.1	1.486	0.333	1.011
Z	54.22	392	35.92	24.25	1.184	5.1	1.305	0.356	1.012

The reported uncertainty of measurement is stated as the standard uncertainty of measurement multiplied by the coverage factor k=2, which for a normal distribution corresponds to a coverage probability of approximately 95%.

<sup>A</sup> The uncertainties of Norm X,Y,Z do not affect the E<sup>2</sup>-field uncertainty inside TSL (see Pages 5 and 6).

<sup>B</sup> Numerical linearization parameter: uncertainty not required.

<sup>E</sup> Uncertainty is determined using the max. deviation from linear response applying rectangular distribution and is expressed for the square of the field value.



## DASY/EASY - Parameters of Probe: ES3DV3 - SN:3209

### Calibration Parameter Determined in Head Tissue Simulating Media

f (MHz) <sup>C</sup>	Relative Permittivity <sup>F</sup>	Conductivity (S/m) <sup>F</sup>	ConvF X	ConvF Y	ConvF Z	Alpha <sup>G</sup>	Depth <sup>G</sup> (mm)	Unc (k=2)
750	41.9	0.89	6.76	6.76	6.76	0.80	1.17	± 12.0 %
835	41.5	0.90	6.36	6.36	6.36	0.63	1.31	± 12.0 %
1750	40.1	1.37	5.50	5.50	5.50	0.74	1.16	± 12.0 %
1900	40.0	1.40	5.31	5.31	5.31	0.63	1.30	± 12.0 %
2300	39.5	1.67	4.92	4.92	4.92	0.80	1.20	± 12.0 %
2450	39.2	1.80	4.72	4.72	4.72	0.71	1.33	± 12.0 %
2600	39.0	1.96	4.53	4.53	4.53	0.69	1.37	± 12.0 %

<sup>C</sup> Frequency validity above 300 MHz of ± 100 MHz only applies for DASY v4.4 and higher (see Page 2), else it is restricted to ± 50 MHz. The uncertainty is the RSS of the ConvF uncertainty at calibration frequency and the uncertainty for the indicated frequency band. Frequency validity below 300 MHz is ± 10, 25, 40, 50 and 70 MHz for ConvF assessments at 30, 64, 128, 150 and 220 MHz respectively. Above 5 GHz frequency validity can be extended to ± 110 MHz.

<sup>F</sup> At frequencies below 3 GHz, the validity of tissue parameters ( $\epsilon$  and  $\sigma$ ) can be relaxed to ± 10% if liquid compensation formula is applied to measured SAR values. At frequencies above 3 GHz, the validity of tissue parameters ( $\epsilon$  and  $\sigma$ ) is restricted to ± 5%. The uncertainty is the RSS of the ConvF uncertainty for indicated target tissue parameters.

<sup>G</sup> Alpha/Depth are determined during calibration. SPEAG warrants that the remaining deviation due to the boundary effect after compensation is always less than ± 1% for frequencies below 3 GHz and below ± 2% for frequencies between 3-6 GHz at any distance larger than half the probe tip diameter from the boundary.

## DASY/EASY - Parameters of Probe: ES3DV3 - SN:3209

### Calibration Parameter Determined in Body Tissue Simulating Media

f (MHz) <sup>C</sup>	Relative Permittivity <sup>F</sup>	Conductivity (S/m) <sup>F</sup>	ConvF X	ConvF Y	ConvF Z	Alpha <sup>G</sup>	Depth <sup>G</sup> (mm)	Unc (k=2)
750	55.5	0.96	6.44	6.44	6.44	0.80	1.17	± 12.0 %
835	55.2	0.97	6.36	6.36	6.36	0.80	1.20	± 12.0 %
1750	53.4	1.49	5.13	5.13	5.13	0.51	1.53	± 12.0 %
1900	53.3	1.52	4.93	4.93	4.93	0.50	1.59	± 12.0 %
2300	52.9	1.81	4.62	4.62	4.62	0.80	1.24	± 12.0 %
2450	52.7	1.95	4.48	4.48	4.48	0.80	1.24	± 12.0 %
2600	52.5	2.16	4.26	4.26	4.26	0.80	1.20	± 12.0 %

<sup>C</sup> Frequency validity above 300 MHz of ± 100 MHz only applies for DASY v4.4 and higher (see Page 2), else it is restricted to ± 50 MHz. The uncertainty is the RSS of the ConvF uncertainty at calibration frequency and the uncertainty for the indicated frequency band. Frequency validity below 300 MHz is ± 10, 25, 40, 50 and 70 MHz for ConvF assessments at 30, 64, 128, 150 and 220 MHz respectively. Above 5 GHz frequency validity can be extended to ± 110 MHz.

<sup>F</sup> At frequencies below 3 GHz, the validity of tissue parameters ( $\epsilon$  and  $\sigma$ ) can be relaxed to ± 10% if liquid compensation formula is applied to measured SAR values. At frequencies above 3 GHz, the validity of tissue parameters ( $\epsilon$  and  $\sigma$ ) is restricted to ± 5%. The uncertainty is the RSS of the ConvF uncertainty for indicated target tissue parameters.

<sup>G</sup> Alpha/Depth are determined during calibration. SPEAG warrants that the remaining deviation due to the boundary effect after compensation is always less than ± 1% for frequencies below 3 GHz and below ± 2% for frequencies between 3-6 GHz at any distance larger than half the probe tip diameter from the boundary.

# Frequency Response of E-Field

(TEM-Cell:ifi110 EXX, Waveguide: R22)

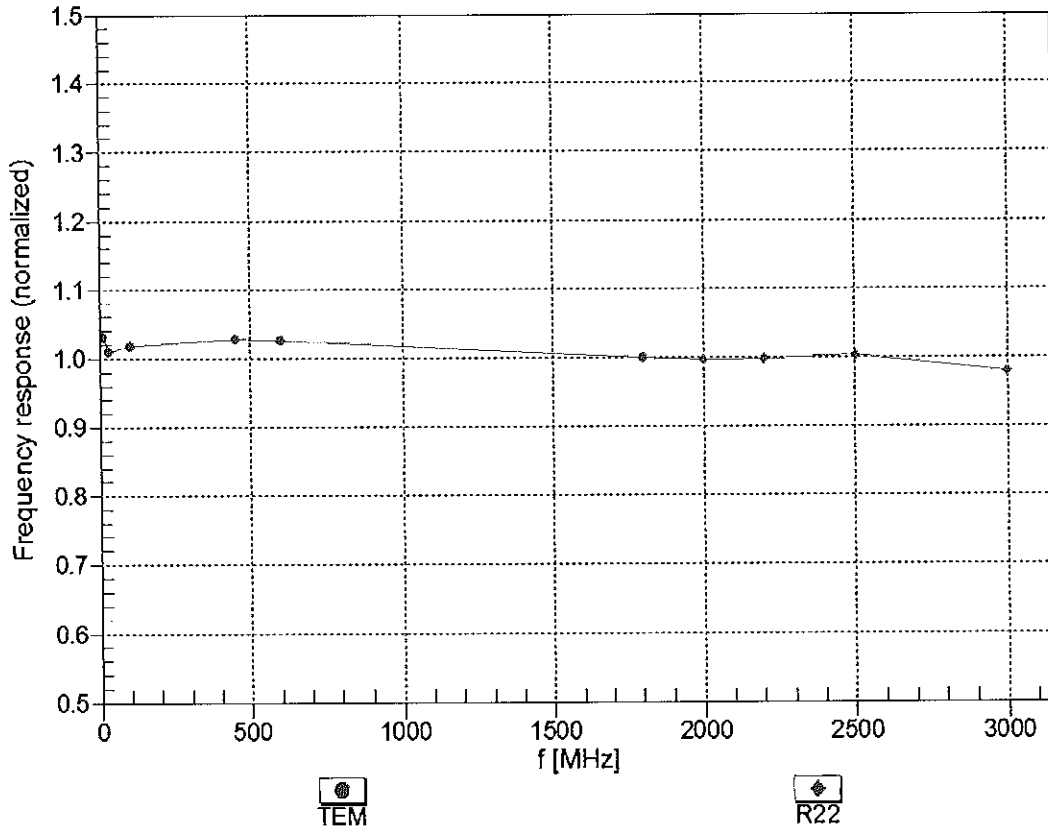

Uncertainty of Frequency Response of E-field:  $\pm 6.3\%$  (k=2)

### Receiving Pattern ( $\phi$ ), $\vartheta = 0^\circ$

f=600 MHz, TEM

f=1800 MHz, R22

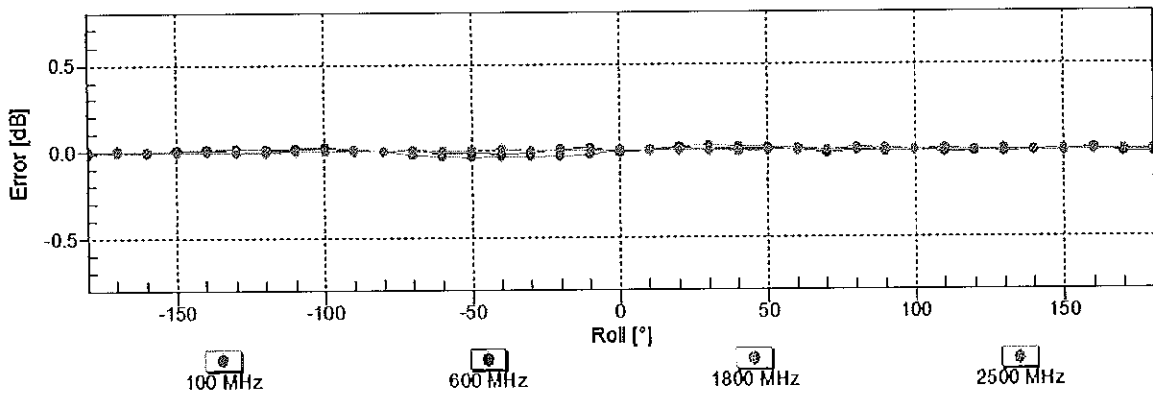
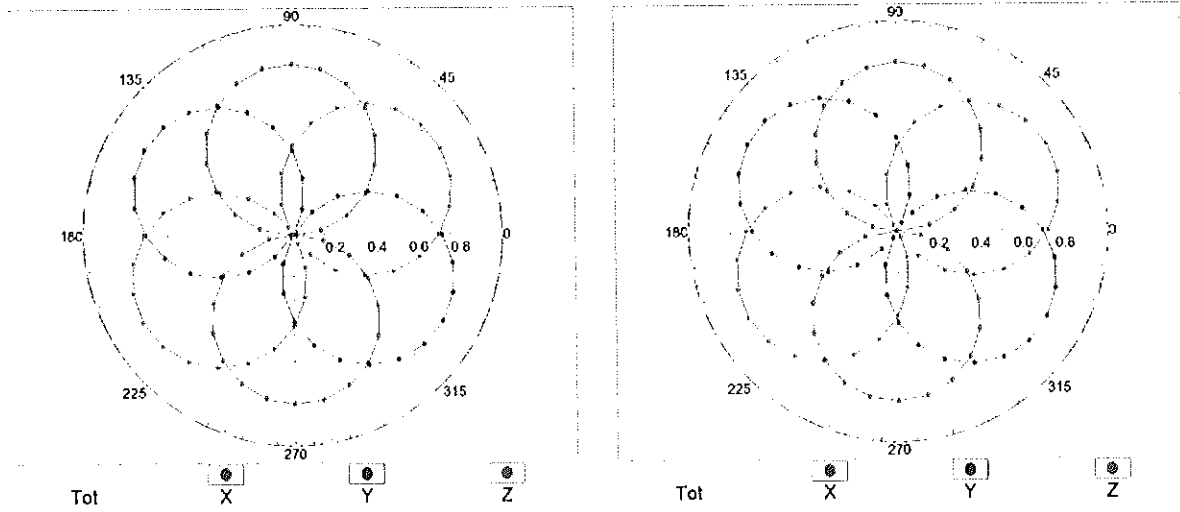

Uncertainty of Axial Isotropy Assessment:  $\pm 0.5\%$  ( $k=2$ )

### Dynamic Range f(SAR<sub>head</sub>) (TEM cell , f<sub>eval</sub>= 1900 MHz)

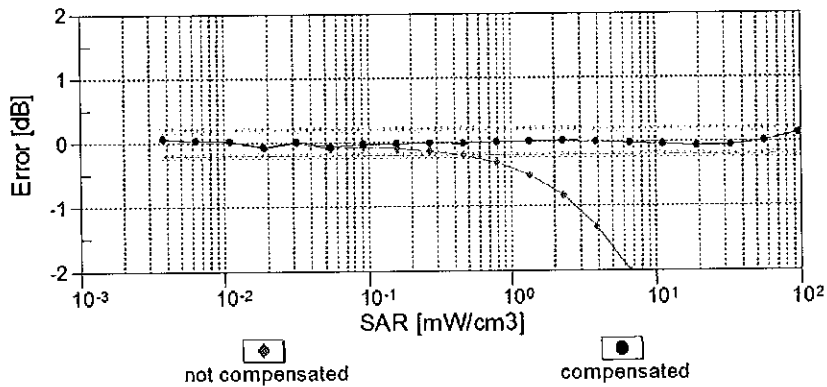
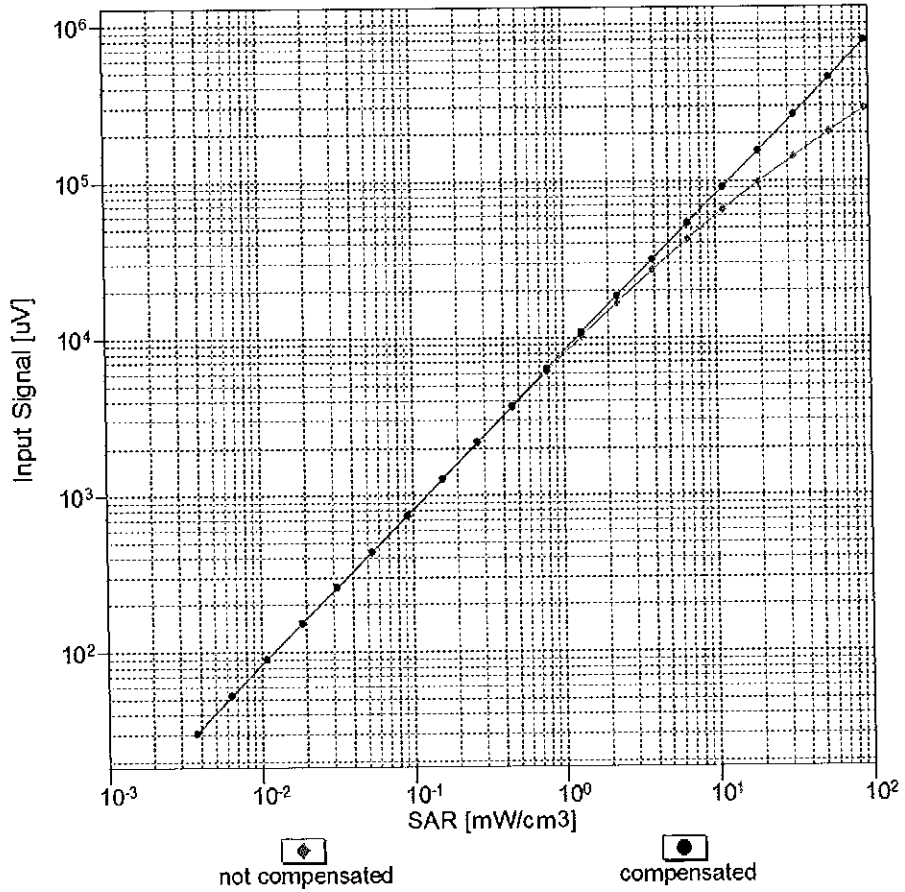

Uncertainty of Linearity Assessment: ± 0.6% (k=2)

# Conversion Factor Assessment

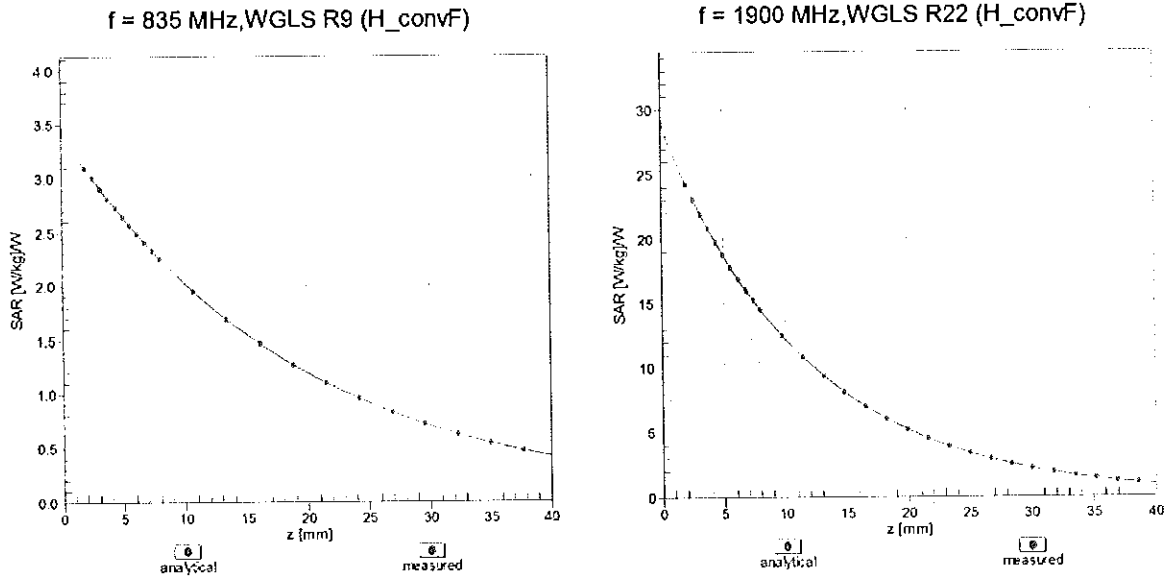

## Deviation from Isotropy in Liquid Error ( $\phi, \theta$ ), f = 900 MHz

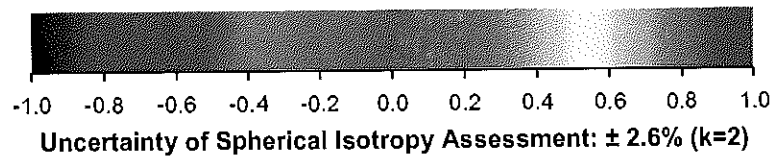
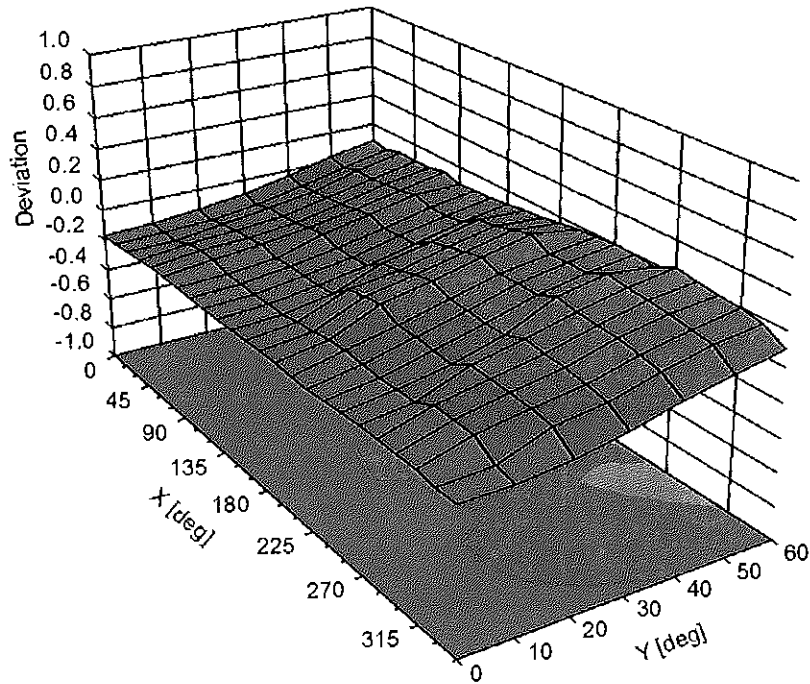

**DASY/EASY - Parameters of Probe: ES3DV3 - SN:3209****Other Probe Parameters**

Sensor Arrangement	Triangular
Connector Angle (°)	-39.9
Mechanical Surface Detection Mode	enabled
Optical Surface Detection Mode	disabled
Probe Overall Length	337 mm
Probe Body Diameter	10 mm
Tip Length	10 mm
Tip Diameter	4 mm
Probe Tip to Sensor X Calibration Point	2 mm
Probe Tip to Sensor Y Calibration Point	2 mm
Probe Tip to Sensor Z Calibration Point	2 mm
Recommended Measurement Distance from Surface	3 mm

**Appendix: Modulation Calibration Parameters**

UID	Communication System Name		A dB	B dB $\sqrt{\mu V}$	C	D dB	VR mV	Max Unc <sup>E</sup> (k=2)
0	CW	X	0.00	0.00	1.00	0.00	185.7	$\pm 3.5\%$
		Y	0.00	0.00	1.00		188.4	
		Z	0.00	0.00	1.00		174.0	
10010- CAA	SAR Validation (Square, 100ms, 10ms)	X	16.56	89.85	21.07	10.00	25.0	$\pm 9.6\%$
		Y	14.18	87.91	20.84		25.0	
		Z	16.46	89.94	21.19		25.0	
10011- CAB	UMTS-FDD (WCDMA)	X	1.31	71.34	17.73	0.00	150.0	$\pm 9.6\%$
		Y	1.07	67.38	15.30		150.0	
		Z	1.14	68.61	16.10		150.0	
10012- CAB	IEEE 802.11b WiFi 2.4 GHz (DSSS, 1 Mbps)	X	1.33	65.77	16.71	0.41	150.0	$\pm 9.6\%$
		Y	1.28	64.69	15.69		150.0	
		Z	1.29	65.03	16.02		150.0	
10013- CAB	IEEE 802.11g WiFi 2.4 GHz (DSSS-OFDM, 6 Mbps)	X	5.11	67.29	17.66	1.46	150.0	$\pm 9.6\%$
		Y	5.08	67.12	17.41		150.0	
		Z	5.08	67.16	17.48		150.0	
10021- DAC	GSM-FDD (TDMA, GMSK)	X	100.00	120.30	31.44	9.39	50.0	$\pm 9.6\%$
		Y	100.00	121.02	32.06		50.0	
		Z	100.00	120.74	31.69		50.0	
10023- DAC	GPRS-FDD (TDMA, GMSK, TN 0)	X	100.00	120.21	31.45	9.57	50.0	$\pm 9.6\%$
		Y	100.00	120.94	32.08		50.0	
		Z	100.00	120.65	31.69		50.0	
10024- DAC	GPRS-FDD (TDMA, GMSK, TN 0-1)	X	100.00	118.31	29.49	6.56	60.0	$\pm 9.6\%$
		Y	100.00	118.38	29.74		60.0	
		Z	100.00	118.51	29.61		60.0	
10025- DAC	EDGE-FDD (TDMA, 8PSK, TN 0)	X	79.79	164.11	61.22	12.57	50.0	$\pm 9.6\%$
		Y	21.03	115.56	45.00		50.0	
		Z	21.02	118.33	46.74		50.0	
10026- DAC	EDGE-FDD (TDMA, 8PSK, TN 0-1)	X	56.10	137.19	47.52	9.56	60.0	$\pm 9.6\%$
		Y	22.58	110.81	38.90		60.0	
		Z	30.67	120.33	42.31		60.0	
10027- DAC	GPRS-FDD (TDMA, GMSK, TN 0-1-2)	X	100.00	118.60	28.85	4.80	80.0	$\pm 9.6\%$
		Y	100.00	117.96	28.73		80.0	
		Z	100.00	118.50	28.81		80.0	
10028- DAC	GPRS-FDD (TDMA, GMSK, TN 0-1-2-3)	X	100.00	120.37	28.91	3.55	100.0	$\pm 9.6\%$
		Y	100.00	118.79	28.36		100.0	
		Z	100.00	119.82	28.67		100.0	
10029- DAC	EDGE-FDD (TDMA, 8PSK, TN 0-1-2)	X	18.11	107.13	37.13	7.80	80.0	$\pm 9.6\%$
		Y	12.22	95.66	32.56		80.0	
		Z	13.69	99.54	34.27		80.0	
10030- CAA	IEEE 802.15.1 Bluetooth (GFSK, DH1)	X	100.00	117.23	28.52	5.30	70.0	$\pm 9.6\%$
		Y	100.00	116.90	28.56		70.0	
		Z	100.00	117.22	28.54		70.0	
10031- CAA	IEEE 802.15.1 Bluetooth (GFSK, DH3)	X	100.00	124.45	29.19	1.88	100.0	$\pm 9.6\%$
		Y	100.00	120.00	27.42		100.0	
		Z	100.00	122.22	28.25		100.0	



10032-CAA	IEEE 802.15.1 Bluetooth (GFSK, DH5)	X	100.00	134.81	32.39	1.17	100.0	± 9.6 %
		Y	100.00	125.40	28.63		100.0	
		Z	100.00	129.61	30.26		100.0	
10033-CAA	IEEE 802.15.1 Bluetooth (PI/4-DQPSK, DH1)	X	100.00	129.27	35.65	5.30	70.0	± 9.6 %
		Y	49.54	115.99	32.11		70.0	
		Z	90.11	126.99	34.97		70.0	
10034-CAA	IEEE 802.15.1 Bluetooth (PI/4-DQPSK, DH3)	X	16.84	102.10	27.13	1.88	100.0	± 9.6 %
		Y	7.82	89.20	22.87		100.0	
		Z	9.48	92.81	24.19		100.0	
10035-CAA	IEEE 802.15.1 Bluetooth (PI/4-DQPSK, DH5)	X	6.67	89.65	23.23	1.17	100.0	± 9.6 %
		Y	3.84	80.35	19.62		100.0	
		Z	4.40	82.90	20.73		100.0	
10036-CAA	IEEE 802.15.1 Bluetooth (8-DPSK, DH1)	X	100.00	129.52	35.77	5.30	70.0	± 9.6 %
		Y	85.34	125.22	34.45		70.0	
		Z	100.00	128.99	35.51		70.0	
10037-CAA	IEEE 802.15.1 Bluetooth (8-DPSK, DH3)	X	15.79	101.19	26.84	1.88	100.0	± 9.6 %
		Y	7.32	88.29	22.54		100.0	
		Z	8.88	91.91	23.88		100.0	
10038-CAA	IEEE 802.15.1 Bluetooth (8-DPSK, DH5)	X	6.96	90.64	23.66	1.17	100.0	± 9.6 %
		Y	3.95	81.00	19.95		100.0	
		Z	4.52	83.60	21.07		100.0	
10039-CAB	CDMA2000 (1xRTT, RC1)	X	2.68	77.46	18.66	0.00	150.0	± 9.6 %
		Y	1.87	71.76	15.92		150.0	
		Z	2.09	73.47	16.81		150.0	
10042-CAB	IS-54 / IS-136 FDD (TDMA/FDM, PI/4-DQPSK, Halfrate)	X	100.00	116.28	28.75	7.78	50.0	± 9.6 %
		Y	100.00	116.68	29.16		50.0	
		Z	100.00	116.58	28.91		50.0	
10044-CAA	IS-91/EIA/TIA-553 FDD (FDMA, FM)	X	0.01	103.03	6.46	0.00	150.0	± 9.6 %
		Y	0.01	95.61	0.65		150.0	
		Z	0.02	122.64	11.17		150.0	
10048-CAA	DECT (TDD, TDMA/FDM, GFSK, Full Slot, 24)	X	100.00	122.27	33.78	13.80	25.0	± 9.6 %
		Y	88.36	120.80	33.95		25.0	
		Z	100.00	122.70	34.06		25.0	
10049-CAA	DECT (TDD, TDMA/FDM, GFSK, Double Slot, 12)	X	100.00	120.46	31.88	10.79	40.0	± 9.6 %
		Y	100.00	121.38	32.63		40.0	
		Z	100.00	120.92	32.14		40.0	
10056-CAA	UMTS-TDD (TD-SCDMA, 1.28 Mcps)	X	64.71	119.17	33.88	9.03	50.0	± 9.6 %
		Y	31.81	105.88	30.24		50.0	
		Z	48.79	114.06	32.52		50.0	
10058-DAC	EDGE-FDD (TDMA, 8PSK, TN 0-1-2-3)	X	10.31	93.78	31.68	6.55	100.0	± 9.6 %
		Y	8.35	87.44	28.76		100.0	
		Z	8.74	89.37	29.77		100.0	
10059-CAB	IEEE 802.11b WiFi 2.4 GHz (DSSS, 2 Mbps)	X	1.47	67.98	17.85	0.61	110.0	± 9.6 %
		Y	1.41	66.57	16.67		110.0	
		Z	1.42	66.96	17.03		110.0	
10060-CAB	IEEE 802.11b WiFi 2.4 GHz (DSSS, 5.5 Mbps)	X	100.00	138.63	36.70	1.30	110.0	± 9.6 %
		Y	100.00	134.16	34.76		110.0	
		Z	100.00	136.34	35.67		110.0	

10061-CAB	IEEE 802.11b WiFi 2.4 GHz (DSSS, 11 Mbps)	X	21.25	113.68	33.06	2.04	110.0	± 9.6 %
		Y	8.67	95.89	27.33		110.0	
		Z	10.38	100.06	28.88		110.0	
10062-CAB	IEEE 802.11a/h WiFi 5 GHz (OFDM, 6 Mbps)	X	4.87	67.16	16.99	0.49	100.0	± 9.6 %
		Y	4.83	66.94	16.72		100.0	
		Z	4.84	67.02	16.80		100.0	
10063-CAB	IEEE 802.11a/h WiFi 5 GHz (OFDM, 9 Mbps)	X	4.90	67.29	17.12	0.72	100.0	± 9.6 %
		Y	4.86	67.08	16.85		100.0	
		Z	4.87	67.15	16.93		100.0	
10064-CAB	IEEE 802.11a/h WiFi 5 GHz (OFDM, 12 Mbps)	X	5.22	67.61	17.38	0.86	100.0	± 9.6 %
		Y	5.17	67.40	17.11		100.0	
		Z	5.19	67.47	17.19		100.0	
10065-CAB	IEEE 802.11a/h WiFi 5 GHz (OFDM, 18 Mbps)	X	5.10	67.59	17.53	1.21	100.0	± 9.6 %
		Y	5.06	67.39	17.27		100.0	
		Z	5.07	67.45	17.34		100.0	
10066-CAB	IEEE 802.11a/h WiFi 5 GHz (OFDM, 24 Mbps)	X	5.14	67.68	17.74	1.46	100.0	± 9.6 %
		Y	5.10	67.48	17.48		100.0	
		Z	5.11	67.54	17.56		100.0	
10067-CAB	IEEE 802.11a/h WiFi 5 GHz (OFDM, 36 Mbps)	X	5.44	67.85	18.21	2.04	100.0	± 9.6 %
		Y	5.41	67.66	17.95		100.0	
		Z	5.41	67.71	18.02		100.0	
10068-CAB	IEEE 802.11a/h WiFi 5 GHz (OFDM, 48 Mbps)	X	5.54	68.11	18.56	2.55	100.0	± 9.6 %
		Y	5.51	67.91	18.28		100.0	
		Z	5.51	67.95	18.36		100.0	
10069-CAB	IEEE 802.11a/h WiFi 5 GHz (OFDM, 54 Mbps)	X	5.62	68.08	18.75	2.67	100.0	± 9.6 %
		Y	5.59	67.88	18.46		100.0	
		Z	5.59	67.92	18.55		100.0	
10071-CAB	IEEE 802.11g WiFi 2.4 GHz (DSSS/OFDM, 9 Mbps)	X	5.23	67.47	18.03	1.99	100.0	± 9.6 %
		Y	5.20	67.30	17.78		100.0	
		Z	5.20	67.34	17.85		100.0	
10072-CAB	IEEE 802.11g WiFi 2.4 GHz (DSSS/OFDM, 12 Mbps)	X	5.25	67.96	18.33	2.30	100.0	± 9.6 %
		Y	5.23	67.77	18.07		100.0	
		Z	5.22	67.81	18.14		100.0	
10073-CAB	IEEE 802.11g WiFi 2.4 GHz (DSSS/OFDM, 18 Mbps)	X	5.35	68.24	18.74	2.83	100.0	± 9.6 %
		Y	5.33	68.06	18.47		100.0	
		Z	5.32	68.08	18.54		100.0	
10074-CAB	IEEE 802.11g WiFi 2.4 GHz (DSSS/OFDM, 24 Mbps)	X	5.35	68.21	18.96	3.30	100.0	± 9.6 %
		Y	5.34	68.06	18.69		100.0	
		Z	5.32	68.06	18.76		100.0	
10075-CAB	IEEE 802.11g WiFi 2.4 GHz (DSSS/OFDM, 36 Mbps)	X	5.45	68.57	19.42	3.82	90.0	± 9.6 %
		Y	5.44	68.40	19.14		90.0	
		Z	5.42	68.40	19.20		90.0	
10076-CAB	IEEE 802.11g WiFi 2.4 GHz (DSSS/OFDM, 48 Mbps)	X	5.44	68.33	19.53	4.15	90.0	± 9.6 %
		Y	5.45	68.18	19.25		90.0	
		Z	5.42	68.16	19.32		90.0	
10077-CAB	IEEE 802.11g WiFi 2.4 GHz (DSSS/OFDM, 54 Mbps)	X	5.47	68.40	19.63	4.30	90.0	± 9.6 %
		Y	5.48	68.26	19.35		90.0	
		Z	5.45	68.24	19.42		90.0	

10081-CAB	CDMA2000 (1xRTT, RC3)	X	1.23	71.08	15.82	0.00	150.0	± 9.6 %
		Y	0.91	66.28	13.04		150.0	
		Z	0.99	67.64	13.91		150.0	
10082-CAB	IS-54 / IS-136 FDD (TDMA/FDM, PI/4-DQPSK, Fullrate)	X	1.44	62.24	7.11	4.77	80.0	± 9.6 %
		Y	1.55	62.44	7.40		80.0	
		Z	1.44	62.17	7.10		80.0	
10090-DAC	GPRS-FDD (TDMA, GMSK, TN 0-4)	X	100.00	118.36	29.54	6.56	60.0	± 9.6 %
		Y	100.00	118.45	29.79		60.0	
		Z	100.00	118.56	29.65		60.0	
10097-CAB	UMTS-FDD (HSDPA)	X	2.01	69.10	16.79	0.00	150.0	± 9.6 %
		Y	1.86	67.49	15.67		150.0	
		Z	1.91	68.05	16.06		150.0	
10098-CAB	UMTS-FDD (HSUPA, Subtest 2)	X	1.98	69.12	16.80	0.00	150.0	± 9.6 %
		Y	1.82	67.46	15.64		150.0	
		Z	1.87	68.03	16.04		150.0	
10099-DAC	EDGE-FDD (TDMA, 8PSK, TN 0-4)	X	56.10	137.12	47.49	9.56	60.0	± 9.6 %
		Y	22.61	110.79	38.89		60.0	
		Z	30.74	120.33	42.30		60.0	
10100-CAC	LTE-FDD (SC-FDMA, 100% RB, 20 MHz, QPSK)	X	3.46	71.82	17.60	0.00	150.0	± 9.6 %
		Y	3.20	70.34	16.69		150.0	
		Z	3.29	70.87	17.01		150.0	
10101-CAC	LTE-FDD (SC-FDMA, 100% RB, 20 MHz, 16-QAM)	X	3.44	68.35	16.55	0.00	150.0	± 9.6 %
		Y	3.33	67.66	16.01		150.0	
		Z	3.37	67.92	16.20		150.0	
10102-CAC	LTE-FDD (SC-FDMA, 100% RB, 20 MHz, 64-QAM)	X	3.53	68.21	16.59	0.00	150.0	± 9.6 %
		Y	3.43	67.60	16.09		150.0	
		Z	3.46	67.83	16.26		150.0	
10103-CAC	LTE-TDD (SC-FDMA, 100% RB, 20 MHz, QPSK)	X	8.71	80.18	22.43	3.98	65.0	± 9.6 %
		Y	8.63	79.54	22.01		65.0	
		Z	8.72	80.06	22.29		65.0	
10104-CAC	LTE-TDD (SC-FDMA, 100% RB, 20 MHz, 16-QAM)	X	8.41	78.26	22.59	3.98	65.0	± 9.6 %
		Y	8.16	77.17	21.90		65.0	
		Z	8.16	77.51	22.15		65.0	
10105-CAC	LTE-TDD (SC-FDMA, 100% RB, 20 MHz, 64-QAM)	X	7.75	76.58	22.19	3.98	65.0	± 9.6 %
		Y	7.29	74.89	21.22		65.0	
		Z	7.40	75.53	21.60		65.0	
10108-CAD	LTE-FDD (SC-FDMA, 100% RB, 10 MHz, QPSK)	X	3.04	71.09	17.48	0.00	150.0	± 9.6 %
		Y	2.81	69.59	16.53		150.0	
		Z	2.89	70.12	16.86		150.0	
10109-CAD	LTE-FDD (SC-FDMA, 100% RB, 10 MHz, 16-QAM)	X	3.10	68.24	16.51	0.00	150.0	± 9.6 %
		Y	2.98	67.47	15.91		150.0	
		Z	3.02	67.76	16.12		150.0	
10110-CAD	LTE-FDD (SC-FDMA, 100% RB, 5 MHz, QPSK)	X	2.51	70.39	17.27	0.00	150.0	± 9.6 %
		Y	2.30	68.71	16.17		150.0	
		Z	2.37	69.29	16.55		150.0	
10111-CAD	LTE-FDD (SC-FDMA, 100% RB, 5 MHz, 16-QAM)	X	2.80	68.98	16.82	0.00	150.0	± 9.6 %
		Y	2.67	68.08	16.14		150.0	
		Z	2.72	68.39	16.37		150.0	

10112-CAD	LTE-FDD (SC-FDMA, 100% RB, 10 MHz, 64-QAM)	X	3.21	68.13	16.51	0.00	150.0	± 9.6 %
		Y	3.11	67.44	15.96		150.0	
		Z	3.14	67.70	16.15		150.0	
10113-CAD	LTE-FDD (SC-FDMA, 100% RB, 5 MHz, 64-QAM)	X	2.94	69.00	16.88	0.00	150.0	± 9.6 %
		Y	2.83	68.20	16.26		150.0	
		Z	2.87	68.48	16.47		150.0	
10114-CAB	IEEE 802.11n (HT Greenfield, 13.5 Mbps, BPSK)	X	5.29	67.60	16.80	0.00	150.0	± 9.6 %
		Y	5.23	67.37	16.54		150.0	
		Z	5.25	67.46	16.62		150.0	
10115-CAB	IEEE 802.11n (HT Greenfield, 81 Mbps, 16-QAM)	X	5.64	67.91	16.97	0.00	150.0	± 9.6 %
		Y	5.58	67.65	16.70		150.0	
		Z	5.60	67.75	16.78		150.0	
10116-CAB	IEEE 802.11n (HT Greenfield, 135 Mbps, 64-QAM)	X	5.42	67.88	16.87	0.00	150.0	± 9.6 %
		Y	5.35	67.63	16.60		150.0	
		Z	5.37	67.72	16.68		150.0	
10117-CAB	IEEE 802.11n (HT Mixed, 13.5 Mbps, BPSK)	X	5.27	67.51	16.78	0.00	150.0	± 9.6 %
		Y	5.21	67.27	16.51		150.0	
		Z	5.23	67.37	16.60		150.0	
10118-CAB	IEEE 802.11n (HT Mixed, 81 Mbps, 16-QAM)	X	5.75	68.18	17.12	0.00	150.0	± 9.6 %
		Y	5.68	67.91	16.83		150.0	
		Z	5.70	68.00	16.92		150.0	
10119-CAB	IEEE 802.11n (HT Mixed, 135 Mbps, 64-QAM)	X	5.39	67.82	16.85	0.00	150.0	± 9.6 %
		Y	5.33	67.57	16.58		150.0	
		Z	5.35	67.66	16.66		150.0	
10140-CAC	LTE-FDD (SC-FDMA, 100% RB, 15 MHz, 16-QAM)	X	3.57	68.23	16.51	0.00	150.0	± 9.6 %
		Y	3.47	67.61	16.01		150.0	
		Z	3.51	67.84	16.19		150.0	
10141-CAC	LTE-FDD (SC-FDMA, 100% RB, 15 MHz, 64-QAM)	X	3.69	68.24	16.63	0.00	150.0	± 9.6 %
		Y	3.59	67.69	16.17		150.0	
		Z	3.63	67.89	16.33		150.0	
10142-CAD	LTE-FDD (SC-FDMA, 100% RB, 3 MHz, QPSK)	X	2.30	70.61	17.13	0.00	150.0	± 9.6 %
		Y	2.07	68.65	15.88		150.0	
		Z	2.15	69.31	16.31		150.0	
10143-CAD	LTE-FDD (SC-FDMA, 100% RB, 3 MHz, 16-QAM)	X	2.70	69.93	16.73	0.00	150.0	± 9.6 %
		Y	2.53	68.73	15.89		150.0	
		Z	2.59	69.14	16.18		150.0	
10144-CAD	LTE-FDD (SC-FDMA, 100% RB, 3 MHz, 64-QAM)	X	2.50	67.93	15.31	0.00	150.0	± 9.6 %
		Y	2.35	66.79	14.47		150.0	
		Z	2.40	67.20	14.77		150.0	
10145-CAD	LTE-FDD (SC-FDMA, 100% RB, 1.4 MHz, QPSK)	X	1.61	68.59	14.32	0.00	150.0	± 9.6 %
		Y	1.36	65.99	12.68		150.0	
		Z	1.44	66.83	13.25		150.0	
10146-CAD	LTE-FDD (SC-FDMA, 100% RB, 1.4 MHz, 16-QAM)	X	4.12	76.15	17.00	0.00	150.0	± 9.6 %
		Y	3.13	71.87	14.86		150.0	
		Z	3.61	74.04	16.00		150.0	
10147-CAD	LTE-FDD (SC-FDMA, 100% RB, 1.4 MHz, 64-QAM)	X	5.91	81.17	19.01	0.00	150.0	± 9.6 %
		Y	4.21	75.86	16.64		150.0	
		Z	5.05	78.62	17.93		150.0	

10149-CAC	LTE-FDD (SC-FDMA, 50% RB, 20 MHz, 16-QAM)	X	3.10	68.30	16.55	0.00	150.0	± 9.6 %
		Y	2.99	67.53	15.95		150.0	
		Z	3.03	67.81	16.16		150.0	
10150-CAC	LTE-FDD (SC-FDMA, 50% RB, 20 MHz, 64-QAM)	X	3.22	68.17	16.55	0.00	150.0	± 9.6 %
		Y	3.11	67.49	16.00		150.0	
		Z	3.15	67.74	16.19		150.0	
10151-CAC	LTE-TDD (SC-FDMA, 50% RB, 20 MHz, QPSK)	X	9.92	84.00	24.01	3.98	65.0	± 9.6 %
		Y	9.28	82.23	23.13		65.0	
		Z	9.42	82.88	23.47		65.0	
10152-CAC	LTE-TDD (SC-FDMA, 50% RB, 20 MHz, 16-QAM)	X	8.12	78.81	22.58	3.98	65.0	± 9.6 %
		Y	7.79	77.46	21.77		65.0	
		Z	7.82	77.90	22.06		65.0	
10153-CAC	LTE-TDD (SC-FDMA, 50% RB, 20 MHz, 64-QAM)	X	8.47	79.51	23.20	3.98	65.0	± 9.6 %
		Y	8.19	78.31	22.47		65.0	
		Z	8.19	78.67	22.72		65.0	
10154-CAD	LTE-FDD (SC-FDMA, 50% RB, 10 MHz, QPSK)	X	2.56	70.77	17.50	0.00	150.0	± 9.6 %
		Y	2.35	69.09	16.42		150.0	
		Z	2.42	69.67	16.79		150.0	
10155-CAD	LTE-FDD (SC-FDMA, 50% RB, 10 MHz, 16-QAM)	X	2.80	68.99	16.83	0.00	150.0	± 9.6 %
		Y	2.68	68.09	16.15		150.0	
		Z	2.72	68.40	16.38		150.0	
10156-CAD	LTE-FDD (SC-FDMA, 50% RB, 5 MHz, QPSK)	X	2.18	71.04	17.14	0.00	150.0	± 9.6 %
		Y	1.92	68.76	15.73		150.0	
		Z	2.01	69.52	16.21		150.0	
10157-CAD	LTE-FDD (SC-FDMA, 50% RB, 5 MHz, 16-QAM)	X	2.37	68.82	15.55	0.00	150.0	± 9.6 %
		Y	2.18	67.35	14.55		150.0	
		Z	2.25	67.86	14.90		150.0	
10158-CAD	LTE-FDD (SC-FDMA, 50% RB, 10 MHz, 64-QAM)	X	2.95	69.05	16.92	0.00	150.0	± 9.6 %
		Y	2.83	68.25	16.30		150.0	
		Z	2.87	68.52	16.51		150.0	
10159-CAD	LTE-FDD (SC-FDMA, 50% RB, 5 MHz, 64-QAM)	X	2.48	69.16	15.77	0.00	150.0	± 9.6 %
		Y	2.29	67.76	14.81		150.0	
		Z	2.35	68.25	15.15		150.0	
10160-CAC	LTE-FDD (SC-FDMA, 50% RB, 15 MHz, QPSK)	X	3.02	70.00	17.21	0.00	150.0	± 9.6 %
		Y	2.84	68.79	16.39		150.0	
		Z	2.90	69.20	16.66		150.0	
10161-CAC	LTE-FDD (SC-FDMA, 50% RB, 15 MHz, 16-QAM)	X	3.11	68.10	16.49	0.00	150.0	± 9.6 %
		Y	3.01	67.41	15.93		150.0	
		Z	3.04	67.66	16.12		150.0	
10162-CAC	LTE-FDD (SC-FDMA, 50% RB, 15 MHz, 64-QAM)	X	3.22	68.18	16.56	0.00	150.0	± 9.6 %
		Y	3.11	67.53	16.02		150.0	
		Z	3.15	67.77	16.21		150.0	
10166-CAD	LTE-FDD (SC-FDMA, 50% RB, 1.4 MHz, QPSK)	X	4.01	71.57	20.55	3.01	150.0	± 9.6 %
		Y	3.96	70.99	19.97		150.0	
		Z	4.00	71.24	20.22		150.0	
10167-CAD	LTE-FDD (SC-FDMA, 50% RB, 1.4 MHz, 16-QAM)	X	5.34	76.03	21.61	3.01	150.0	± 9.6 %
		Y	5.24	75.14	20.90		150.0	
		Z	5.29	75.43	21.17		150.0	

10168-CAD	LTE-FDD (SC-FDMA, 50% RB, 1.4 MHz, 64-QAM)	X	5.92	78.26	22.84	3.01	150.0	± 9.6 %
		Y	5.88	77.64	22.28		150.0	
		Z	5.88	77.74	22.45		150.0	
10169-CAC	LTE-FDD (SC-FDMA, 1 RB, 20 MHz, QPSK)	X	3.56	72.83	21.25	3.01	150.0	± 9.6 %
		Y	3.54	72.03	20.47		150.0	
		Z	3.57	72.33	20.78		150.0	
10170-CAC	LTE-FDD (SC-FDMA, 1 RB, 20 MHz, 16-QAM)	X	5.89	82.52	24.81	3.01	150.0	± 9.6 %
		Y	5.80	81.18	23.85		150.0	
		Z	5.77	81.27	24.06		150.0	
10171-AAC	LTE-FDD (SC-FDMA, 1 RB, 20 MHz, 64-QAM)	X	4.66	77.30	21.81	3.01	150.0	± 9.6 %
		Y	4.48	75.56	20.63		150.0	
		Z	4.56	76.10	21.06		150.0	
10172-CAC	LTE-TDD (SC-FDMA, 1 RB, 20 MHz, QPSK)	X	100.00	142.02	43.67	6.02	65.0	± 9.6 %
		Y	29.14	113.86	35.69		65.0	
		Z	42.14	122.72	38.48		65.0	
10173-CAC	LTE-TDD (SC-FDMA, 1 RB, 20 MHz, 16-QAM)	X	100.00	131.99	38.44	6.02	65.0	± 9.6 %
		Y	100.00	129.98	37.53		65.0	
		Z	100.00	131.24	38.14		65.0	
10174-CAC	LTE-TDD (SC-FDMA, 1 RB, 20 MHz, 64-QAM)	X	100.00	130.14	37.45	6.02	65.0	± 9.6 %
		Y	100.00	127.86	36.41		65.0	
		Z	91.70	127.77	36.74		65.0	
10175-CAD	LTE-FDD (SC-FDMA, 1 RB, 10 MHz, QPSK)	X	3.52	72.50	21.01	3.01	150.0	± 9.6 %
		Y	3.49	71.66	20.21		150.0	
		Z	3.53	71.99	20.53		150.0	
10176-CAD	LTE-FDD (SC-FDMA, 1 RB, 10 MHz, 16-QAM)	X	5.90	82.55	24.82	3.01	150.0	± 9.6 %
		Y	5.81	81.21	23.86		150.0	
		Z	5.78	81.30	24.07		150.0	
10177-CAF	LTE-FDD (SC-FDMA, 1 RB, 5 MHz, QPSK)	X	3.55	72.66	21.10	3.01	150.0	± 9.6 %
		Y	3.52	71.84	20.31		150.0	
		Z	3.56	72.16	20.62		150.0	
10178-CAD	LTE-FDD (SC-FDMA, 1 RB, 5 MHz, 16-QAM)	X	5.82	82.23	24.68	3.01	150.0	± 9.6 %
		Y	5.72	80.87	23.70		150.0	
		Z	5.70	80.99	23.93		150.0	
10179-CAD	LTE-FDD (SC-FDMA, 1 RB, 10 MHz, 64-QAM)	X	5.25	79.82	23.19	3.01	150.0	± 9.6 %
		Y	5.07	78.18	22.08		150.0	
		Z	5.12	78.56	22.43		150.0	
10180-CAD	LTE-FDD (SC-FDMA, 1 RB, 5 MHz, 64-QAM)	X	4.65	77.21	21.76	3.01	150.0	± 9.6 %
		Y	4.46	75.45	20.57		150.0	
		Z	4.54	76.00	21.00		150.0	
10181-CAC	LTE-FDD (SC-FDMA, 1 RB, 15 MHz, QPSK)	X	3.55	72.65	21.10	3.01	150.0	± 9.6 %
		Y	3.51	71.82	20.30		150.0	
		Z	3.55	72.14	20.62		150.0	
10182-CAC	LTE-FDD (SC-FDMA, 1 RB, 15 MHz, 16-QAM)	X	5.81	82.20	24.67	3.01	150.0	± 9.6 %
		Y	5.71	80.84	23.69		150.0	
		Z	5.69	80.96	23.92		150.0	
10183-AAB	LTE-FDD (SC-FDMA, 1 RB, 15 MHz, 64-QAM)	X	4.64	77.18	21.74	3.01	150.0	± 9.6 %
		Y	4.45	75.42	20.56		150.0	
		Z	4.53	75.97	20.99		150.0	

10184-CAD	LTE-FDD (SC-FDMA, 1 RB, 3 MHz, QPSK)	X	3.56	72.69	21.12	3.01	150.0	± 9.6 %
		Y	3.53	71.87	20.33		150.0	
		Z	3.57	72.19	20.64		150.0	
10185-CAD	LTE-FDD (SC-FDMA, 1 RB, 3 MHz, 16-QAM)	X	5.84	82.29	24.71	3.01	150.0	± 9.6 %
		Y	5.74	80.94	23.73		150.0	
		Z	5.72	81.05	23.96		150.0	
10186-AAD	LTE-FDD (SC-FDMA, 1 RB, 3 MHz, 64-QAM)	X	4.67	77.27	21.78	3.01	150.0	± 9.6 %
		Y	4.47	75.51	20.59		150.0	
		Z	4.56	76.06	21.03		150.0	
10187-CAD	LTE-FDD (SC-FDMA, 1 RB, 1.4 MHz, QPSK)	X	3.57	72.74	21.18	3.01	150.0	± 9.6 %
		Y	3.54	71.92	20.39		150.0	
		Z	3.58	72.24	20.70		150.0	
10188-CAD	LTE-FDD (SC-FDMA, 1 RB, 1.4 MHz, 16-QAM)	X	6.08	83.16	25.13	3.01	150.0	± 9.6 %
		Y	6.00	81.87	24.19		150.0	
		Z	5.95	81.90	24.38		150.0	
10189-AAD	LTE-FDD (SC-FDMA, 1 RB, 1.4 MHz, 64-QAM)	X	4.80	77.83	22.09	3.01	150.0	± 9.6 %
		Y	4.61	76.08	20.92		150.0	
		Z	4.69	76.60	21.33		150.0	
10193-CAB	IEEE 802.11n (HT Greenfield, 6.5 Mbps, BPSK)	X	4.68	66.98	16.53	0.00	150.0	± 9.6 %
		Y	4.62	66.73	16.24		150.0	
		Z	4.64	66.83	16.34		150.0	
10194-CAB	IEEE 802.11n (HT Greenfield, 39 Mbps, 16-QAM)	X	4.86	67.32	16.65	0.00	150.0	± 9.6 %
		Y	4.81	67.07	16.37		150.0	
		Z	4.83	67.17	16.46		150.0	
10195-CAB	IEEE 802.11n (HT Greenfield, 65 Mbps, 64-QAM)	X	4.91	67.35	16.66	0.00	150.0	± 9.6 %
		Y	4.85	67.10	16.38		150.0	
		Z	4.87	67.20	16.47		150.0	
10196-CAB	IEEE 802.11n (HT Mixed, 6.5 Mbps, BPSK)	X	4.69	67.06	16.56	0.00	150.0	± 9.6 %
		Y	4.63	66.81	16.27		150.0	
		Z	4.65	66.91	16.37		150.0	
10197-CAB	IEEE 802.11n (HT Mixed, 39 Mbps, 16-QAM)	X	4.88	67.35	16.66	0.00	150.0	± 9.6 %
		Y	4.82	67.09	16.38		150.0	
		Z	4.84	67.19	16.47		150.0	
10198-CAB	IEEE 802.11n (HT Mixed, 65 Mbps, 64-QAM)	X	4.91	67.37	16.68	0.00	150.0	± 9.6 %
		Y	4.85	67.12	16.39		150.0	
		Z	4.87	67.22	16.49		150.0	
10219-CAB	IEEE 802.11n (HT Mixed, 7.2 Mbps, BPSK)	X	4.64	67.08	16.52	0.00	150.0	± 9.6 %
		Y	4.58	66.82	16.23		150.0	
		Z	4.60	66.92	16.33		150.0	
10220-CAB	IEEE 802.11n (HT Mixed, 43.3 Mbps, 16-QAM)	X	4.88	67.33	16.66	0.00	150.0	± 9.6 %
		Y	4.82	67.07	16.37		150.0	
		Z	4.84	67.17	16.47		150.0	
10221-CAB	IEEE 802.11n (HT Mixed, 72.2 Mbps, 64-QAM)	X	4.92	67.29	16.66	0.00	150.0	± 9.6 %
		Y	4.86	67.05	16.38		150.0	
		Z	4.88	67.14	16.47		150.0	
10222-CAB	IEEE 802.11n (HT Mixed, 15 Mbps, BPSK)	X	5.24	67.52	16.77	0.00	150.0	± 9.6 %
		Y	5.18	67.28	16.51		150.0	
		Z	5.21	67.38	16.59		150.0	

10223-CAB	IEEE 802.11n (HT Mixed, 90 Mbps, 16-QAM)	X	5.57	67.76	16.92	0.00	150.0	± 9.6 %
		Y	5.51	67.51	16.65		150.0	
		Z	5.53	67.60	16.73		150.0	
10224-CAB	IEEE 802.11n (HT Mixed, 150 Mbps, 64-QAM)	X	5.29	67.62	16.75	0.00	150.0	± 9.6 %
		Y	5.23	67.38	16.48		150.0	
		Z	5.25	67.47	16.57		150.0	
10225-CAB	UMTS-FDD (HSPA+)	X	2.96	66.72	15.94	0.00	150.0	± 9.6 %
		Y	2.88	66.18	15.44		150.0	
		Z	2.91	66.38	15.61		150.0	
10226-CAA	LTE-TDD (SC-FDMA, 1 RB, 1.4 MHz, 16-QAM)	X	100.00	132.19	38.58	6.02	65.0	± 9.6 %
		Y	100.00	130.20	37.67		65.0	
		Z	100.00	131.44	38.27		65.0	
10227-CAA	LTE-TDD (SC-FDMA, 1 RB, 1.4 MHz, 64-QAM)	X	100.00	129.74	37.30	6.02	65.0	± 9.6 %
		Y	100.00	127.95	36.49		65.0	
		Z	100.00	129.11	37.05		65.0	
10228-CAA	LTE-TDD (SC-FDMA, 1 RB, 1.4 MHz, QPSK)	X	100.00	141.90	43.60	6.02	65.0	± 9.6 %
		Y	64.28	130.08	40.04		65.0	
		Z	94.90	139.78	42.86		65.0	
10229-CAB	LTE-TDD (SC-FDMA, 1 RB, 3 MHz, 16-QAM)	X	100.00	131.97	38.44	6.02	65.0	± 9.6 %
		Y	100.00	129.97	37.54		65.0	
		Z	100.00	131.22	38.14		65.0	
10230-CAB	LTE-TDD (SC-FDMA, 1 RB, 3 MHz, 64-QAM)	X	100.00	129.60	37.20	6.02	65.0	± 9.6 %
		Y	100.00	127.79	36.39		65.0	
		Z	100.00	128.96	36.95		65.0	
10231-CAB	LTE-TDD (SC-FDMA, 1 RB, 3 MHz, QPSK)	X	100.00	141.75	43.50	6.02	65.0	± 9.6 %
		Y	57.85	127.76	39.37		65.0	
		Z	84.57	137.19	42.14		65.0	
10232-CAC	LTE-TDD (SC-FDMA, 1 RB, 5 MHz, 16-QAM)	X	100.00	131.99	38.45	6.02	65.0	± 9.6 %
		Y	100.00	129.98	37.54		65.0	
		Z	100.00	131.24	38.14		65.0	
10233-CAC	LTE-TDD (SC-FDMA, 1 RB, 5 MHz, 64-QAM)	X	100.00	129.61	37.21	6.02	65.0	± 9.6 %
		Y	100.00	127.81	36.39		65.0	
		Z	100.00	128.97	36.95		65.0	
10234-CAC	LTE-TDD (SC-FDMA, 1 RB, 5 MHz, QPSK)	X	100.00	141.44	43.31	6.02	65.0	± 9.6 %
		Y	52.53	125.50	38.67		65.0	
		Z	75.93	134.62	41.39		65.0	
10235-CAC	LTE-TDD (SC-FDMA, 1 RB, 10 MHz, 16-QAM)	X	100.00	132.00	38.45	6.02	65.0	± 9.6 %
		Y	100.00	130.00	37.54		65.0	
		Z	100.00	131.25	38.15		65.0	
10236-CAC	LTE-TDD (SC-FDMA, 1 RB, 10 MHz, 64-QAM)	X	100.00	129.56	37.18	6.02	65.0	± 9.6 %
		Y	100.00	127.76	36.37		65.0	
		Z	100.00	128.92	36.93		65.0	
10237-CAC	LTE-TDD (SC-FDMA, 1 RB, 10 MHz, QPSK)	X	100.00	141.78	43.50	6.02	65.0	± 9.6 %
		Y	58.86	128.14	39.47		65.0	
		Z	86.67	137.73	42.28		65.0	
10238-CAC	LTE-TDD (SC-FDMA, 1 RB, 15 MHz, 16-QAM)	X	100.00	132.00	38.45	6.02	65.0	± 9.6 %
		Y	100.00	129.99	37.54		65.0	
		Z	100.00	131.25	38.14		65.0	



10239-CAC	LTE-TDD (SC-FDMA, 1 RB, 15 MHz, 64-QAM)	X	100.00	129.64	37.21	6.02	65.0	± 9.6 %
		Y	100.00	127.83	36.40		65.0	
		Z	100.00	129.00	36.96		65.0	
10240-CAC	LTE-TDD (SC-FDMA, 1 RB, 15 MHz, QPSK)	X	100.00	141.80	43.51	6.02	65.0	± 9.6 %
		Y	58.51	128.03	39.44		65.0	
		Z	86.02	137.59	42.24		65.0	
10241-CAA	LTE-TDD (SC-FDMA, 50% RB, 1.4 MHz, 16-QAM)	X	13.65	92.13	30.26	6.98	65.0	± 9.6 %
		Y	12.73	89.47	28.84		65.0	
		Z	12.83	90.19	29.33		65.0	
10242-CAA	LTE-TDD (SC-FDMA, 50% RB, 1.4 MHz, 64-QAM)	X	11.56	88.33	28.75	6.98	65.0	± 9.6 %
		Y	12.17	88.47	28.39		65.0	
		Z	10.55	85.79	27.57		65.0	
10243-CAA	LTE-TDD (SC-FDMA, 50% RB, 1.4 MHz, QPSK)	X	8.75	83.84	28.04	6.98	65.0	± 9.6 %
		Y	9.16	83.97	27.64		65.0	
		Z	8.20	81.83	26.97		65.0	
10244-CAB	LTE-TDD (SC-FDMA, 50% RB, 3 MHz, 16-QAM)	X	11.15	85.22	22.92	3.98	65.0	± 9.6 %
		Y	10.49	83.51	22.06		65.0	
		Z	10.74	84.39	22.53		65.0	
10245-CAB	LTE-TDD (SC-FDMA, 50% RB, 3 MHz, 64-QAM)	X	10.71	84.28	22.53	3.98	65.0	± 9.6 %
		Y	10.12	82.65	21.69		65.0	
		Z	10.34	83.48	22.15		65.0	
10246-CAB	LTE-TDD (SC-FDMA, 50% RB, 3 MHz, QPSK)	X	11.99	89.44	24.35	3.98	65.0	± 9.6 %
		Y	10.01	85.73	22.85		65.0	
		Z	10.59	87.16	23.46		65.0	
10247-CAC	LTE-TDD (SC-FDMA, 50% RB, 5 MHz, 16-QAM)	X	7.78	79.88	21.56	3.98	65.0	± 9.6 %
		Y	7.39	78.44	20.77		65.0	
		Z	7.42	78.92	21.06		65.0	
10248-CAC	LTE-TDD (SC-FDMA, 50% RB, 5 MHz, 64-QAM)	X	7.68	79.17	21.27	3.98	65.0	± 9.6 %
		Y	7.29	77.74	20.47		65.0	
		Z	7.33	78.22	20.77		65.0	
10249-CAC	LTE-TDD (SC-FDMA, 50% RB, 5 MHz, QPSK)	X	13.65	92.24	26.09	3.98	65.0	± 9.6 %
		Y	11.34	88.25	24.50		65.0	
		Z	12.01	89.77	25.14		65.0	
10250-CAC	LTE-TDD (SC-FDMA, 50% RB, 10 MHz, 16-QAM)	X	8.65	81.91	23.79	3.98	65.0	± 9.6 %
		Y	8.26	80.45	22.98		65.0	
		Z	8.27	80.90	23.26		65.0	
10251-CAC	LTE-TDD (SC-FDMA, 50% RB, 10 MHz, 64-QAM)	X	8.08	79.43	22.51	3.98	65.0	± 9.6 %
		Y	7.71	78.00	21.68		65.0	
		Z	7.74	78.46	21.99		65.0	
10252-CAC	LTE-TDD (SC-FDMA, 50% RB, 10 MHz, QPSK)	X	11.90	89.42	25.97	3.98	65.0	± 9.6 %
		Y	10.50	86.42	24.67		65.0	
		Z	10.87	87.52	25.18		65.0	
10253-CAC	LTE-TDD (SC-FDMA, 50% RB, 15 MHz, 16-QAM)	X	7.84	78.03	22.28	3.98	65.0	± 9.6 %
		Y	7.57	76.80	21.51		65.0	
		Z	7.57	77.19	21.79		65.0	
10254-CAC	LTE-TDD (SC-FDMA, 50% RB, 15 MHz, 64-QAM)	X	8.21	78.77	22.87	3.98	65.0	± 9.6 %
		Y	7.97	77.64	22.16		65.0	
		Z	7.95	77.97	22.41		65.0	

10255-CAC	LTE-TDD (SC-FDMA, 50% RB, 15 MHz, QPSK)	X	9.44	83.41	24.04	3.98	65.0	± 9.6 %
		Y	8.86	81.64	23.14		65.0	
		Z	8.96	82.26	23.48		65.0	
10256-CAA	LTE-TDD (SC-FDMA, 100% RB, 1.4 MHz, 16-QAM)	X	9.33	81.69	20.68	3.98	65.0	± 9.6 %
		Y	8.73	79.97	19.81		65.0	
		Z	9.01	80.96	20.33		65.0	
10257-CAA	LTE-TDD (SC-FDMA, 100% RB, 1.4 MHz, 64-QAM)	X	8.80	80.36	20.09	3.98	65.0	± 9.6 %
		Y	8.27	78.77	19.26		65.0	
		Z	8.51	79.68	19.75		65.0	
10258-CAA	LTE-TDD (SC-FDMA, 100% RB, 1.4 MHz, QPSK)	X	9.10	84.22	21.80	3.98	65.0	± 9.6 %
		Y	7.87	81.28	20.53		65.0	
		Z	8.20	82.41	21.04		65.0	
10259-CAB	LTE-TDD (SC-FDMA, 100% RB, 3 MHz, 16-QAM)	X	8.13	80.62	22.35	3.98	65.0	± 9.6 %
		Y	7.73	79.15	21.54		65.0	
		Z	7.76	79.63	21.84		65.0	
10260-CAB	LTE-TDD (SC-FDMA, 100% RB, 3 MHz, 64-QAM)	X	8.07	80.16	22.18	3.98	65.0	± 9.6 %
		Y	7.70	78.77	21.40		65.0	
		Z	7.73	79.22	21.69		65.0	
10261-CAB	LTE-TDD (SC-FDMA, 100% RB, 3 MHz, QPSK)	X	11.98	89.88	25.68	3.98	65.0	± 9.6 %
		Y	10.32	86.47	24.25		65.0	
		Z	10.77	87.74	24.81		65.0	
10262-CAC	LTE-TDD (SC-FDMA, 100% RB, 5 MHz, 16-QAM)	X	8.64	81.87	23.76	3.98	65.0	± 9.6 %
		Y	8.25	80.40	22.94		65.0	
		Z	8.26	80.85	23.23		65.0	
10263-CAC	LTE-TDD (SC-FDMA, 100% RB, 5 MHz, 64-QAM)	X	8.06	79.41	22.51	3.98	65.0	± 9.6 %
		Y	7.70	77.98	21.68		65.0	
		Z	7.73	78.44	21.98		65.0	
10264-CAC	LTE-TDD (SC-FDMA, 100% RB, 5 MHz, QPSK)	X	11.79	89.22	25.88	3.98	65.0	± 9.6 %
		Y	10.40	86.22	24.58		65.0	
		Z	10.77	87.33	25.09		65.0	
10265-CAC	LTE-TDD (SC-FDMA, 100% RB, 10 MHz, 16-QAM)	X	8.12	78.81	22.58	3.98	65.0	± 9.6 %
		Y	7.79	77.46	21.77		65.0	
		Z	7.81	77.90	22.07		65.0	
10266-CAC	LTE-TDD (SC-FDMA, 100% RB, 10 MHz, 64-QAM)	X	8.47	79.50	23.19	3.98	65.0	± 9.6 %
		Y	8.19	78.30	22.46		65.0	
		Z	8.19	78.66	22.72		65.0	
10267-CAC	LTE-TDD (SC-FDMA, 100% RB, 10 MHz, QPSK)	X	9.89	83.95	23.99	3.98	65.0	± 9.6 %
		Y	9.26	82.18	23.11		65.0	
		Z	9.39	82.83	23.45		65.0	
10268-CAC	LTE-TDD (SC-FDMA, 100% RB, 15 MHz, 16-QAM)	X	8.44	77.80	22.53	3.98	65.0	± 9.6 %
		Y	8.24	76.84	21.89		65.0	
		Z	8.22	77.13	22.11		65.0	
10269-CAC	LTE-TDD (SC-FDMA, 100% RB, 15 MHz, 64-QAM)	X	8.33	77.26	22.37	3.98	65.0	± 9.6 %
		Y	8.15	76.36	21.76		65.0	
		Z	8.12	76.62	21.97		65.0	
10270-CAC	LTE-TDD (SC-FDMA, 100% RB, 15 MHz, QPSK)	X	8.75	79.75	22.52	3.98	65.0	± 9.6 %
		Y	8.49	78.72	21.92		65.0	
		Z	8.50	79.07	22.14		65.0	

10274-CAB	UMTS-FDD (HSUPA, Subtest 5, 3GPP Rel8.10)	X	2.73	67.18	15.92	0.00	150.0	± 9.6 %
		Y	2.64	66.46	15.31		150.0	
		Z	2.68	66.73	15.52		150.0	
10275-CAB	UMTS-FDD (HSUPA, Subtest 5, 3GPP Rel8.4)	X	1.87	70.21	17.08	0.00	150.0	± 9.6 %
		Y	1.66	67.87	15.58		150.0	
		Z	1.73	68.66	16.09		150.0	
10277-CAA	PHS (QPSK)	X	3.84	66.56	11.27	9.03	50.0	± 9.6 %
		Y	4.12	66.98	11.68		50.0	
		Z	3.85	66.55	11.29		50.0	
10278-CAA	PHS (QPSK, BW 884MHz, Rolloff 0.5)	X	11.65	86.02	22.30	9.03	50.0	± 9.6 %
		Y	10.21	83.31	21.39		50.0	
		Z	10.96	84.97	21.93		50.0	
10279-CAA	PHS (QPSK, BW 884MHz, Rolloff 0.38)	X	11.92	86.31	22.44	9.03	50.0	± 9.6 %
		Y	10.38	83.50	21.49		50.0	
		Z	11.18	85.20	22.04		50.0	
10290-AAB	CDMA2000, RC1, SO55, Full Rate	X	2.05	73.37	16.75	0.00	150.0	± 9.6 %
		Y	1.54	68.94	14.39		150.0	
		Z	1.68	70.29	15.17		150.0	
10291-AAB	CDMA2000, RC3, SO55, Full Rate	X	1.19	70.69	15.63	0.00	150.0	± 9.6 %
		Y	0.89	66.06	12.92		150.0	
		Z	0.97	67.37	13.76		150.0	
10292-AAB	CDMA2000, RC3, SO32, Full Rate	X	1.82	77.98	19.13	0.00	150.0	± 9.6 %
		Y	1.09	69.78	15.12		150.0	
		Z	1.26	72.00	16.33		150.0	
10293-AAB	CDMA2000, RC3, SO3, Full Rate	X	3.13	86.75	22.80	0.00	150.0	± 9.6 %
		Y	1.53	74.84	17.78		150.0	
		Z	1.85	77.92	19.23		150.0	
10295-AAB	CDMA2000, RC1, SO3, 1/8th Rate 25 fr.	X	16.24	95.47	28.50	9.03	50.0	± 9.6 %
		Y	13.39	90.69	26.64		50.0	
		Z	14.20	92.62	27.44		50.0	
10297-AAB	LTE-FDD (SC-FDMA, 50% RB, 20 MHz, QPSK)	X	3.05	71.18	17.54	0.00	150.0	± 9.6 %
		Y	2.82	69.68	16.59		150.0	
		Z	2.90	70.21	16.92		150.0	
10298-AAC	LTE-FDD (SC-FDMA, 50% RB, 3 MHz, QPSK)	X	1.96	70.66	16.14	0.00	150.0	± 9.6 %
		Y	1.66	67.94	14.50		150.0	
		Z	1.76	68.83	15.06		150.0	
10299-AAC	LTE-FDD (SC-FDMA, 50% RB, 3 MHz, 16-QAM)	X	4.77	78.24	18.75	0.00	150.0	± 9.6 %
		Y	3.92	74.76	16.99		150.0	
		Z	4.32	76.42	17.88		150.0	
10300-AAC	LTE-FDD (SC-FDMA, 50% RB, 3 MHz, 64-QAM)	X	3.00	70.52	14.82	0.00	150.0	± 9.6 %
		Y	2.63	68.29	13.44		150.0	
		Z	2.81	69.37	14.14		150.0	
10301-AAA	IEEE 802.16e WiMAX (29:18, 5ms, 10MHz, QPSK, PUSC)	X	5.51	68.11	19.09	4.17	80.0	± 9.6 %
		Y	5.33	67.16	18.33		80.0	
		Z	5.40	67.58	18.66		80.0	
10302-AAA	IEEE 802.16e WiMAX (29:18, 5ms, 10MHz, QPSK, PUSC, 3 CTRL symbols)	X	5.91	68.43	19.68	4.96	80.0	± 9.6 %
		Y	5.80	67.70	19.02		80.0	
		Z	5.81	67.92	19.25		80.0	

10303-AAA	IEEE 802.16e WiMAX (31:15, 5ms, 10MHz, 64QAM, PUSC)	X	5.70	68.33	19.67	4.96	80.0	± 9.6 %
		Y	5.59	67.57	18.98		80.0	
		Z	5.60	67.78	19.21		80.0	
10304-AAA	IEEE 802.16e WiMAX (29:18, 5ms, 10MHz, 64QAM, PUSC)	X	5.41	67.77	18.89	4.17	80.0	± 9.6 %
		Y	5.31	67.11	18.28		80.0	
		Z	5.33	67.30	18.48		80.0	
10305-AAA	IEEE 802.16e WiMAX (31:15, 10ms, 10MHz, 64QAM, PUSC, 15 symbols)	X	6.16	75.00	23.87	6.02	50.0	± 9.6 %
		Y	6.03	73.79	22.78		50.0	
		Z	5.90	73.64	22.94		50.0	
10306-AAA	IEEE 802.16e WiMAX (29:18, 10ms, 10MHz, 64QAM, PUSC, 18 symbols)	X	5.76	70.24	21.37	6.02	50.0	± 9.6 %
		Y	5.59	69.03	20.35		50.0	
		Z	5.60	69.33	20.68		50.0	
10307-AAA	IEEE 802.16e WiMAX (29:18, 10ms, 10MHz, QPSK, PUSC, 18 symbols)	X	5.75	70.76	21.47	6.02	50.0	± 9.6 %
		Y	5.78	71.13	21.51		50.0	
		Z	5.57	69.74	20.73		50.0	
10308-AAA	IEEE 802.16e WiMAX (29:18, 10ms, 10MHz, 16QAM, PUSC)	X	5.77	71.12	21.68	6.02	50.0	± 9.6 %
		Y	5.80	71.54	21.74		50.0	
		Z	5.57	70.05	20.90		50.0	
10309-AAA	IEEE 802.16e WiMAX (29:18, 10ms, 10MHz, 16QAM, AMC 2x3, 18 symbols)	X	5.87	70.63	21.59	6.02	50.0	± 9.6 %
		Y	5.68	69.33	20.52		50.0	
		Z	5.69	69.66	20.87		50.0	
10310-AAA	IEEE 802.16e WiMAX (29:18, 10ms, 10MHz, QPSK, AMC 2x3, 18 symbols)	X	5.74	70.42	21.38	6.02	50.0	± 9.6 %
		Y	5.56	69.17	20.34		50.0	
		Z	5.57	69.47	20.67		50.0	
10311-AAB	LTE-FDD (SC-FDMA, 100% RB, 15 MHz, QPSK)	X	3.41	70.28	17.06	0.00	150.0	± 9.6 %
		Y	3.18	68.96	16.24		150.0	
		Z	3.26	69.44	16.53		150.0	
10313-AAA	iDEN 1:3	X	11.93	87.85	22.00	6.99	70.0	± 9.6 %
		Y	8.95	83.03	20.34		70.0	
		Z	9.92	85.08	21.06		70.0	
10314-AAA	iDEN 1:6	X	19.66	101.09	29.03	10.00	30.0	± 9.6 %
		Y	13.64	93.68	26.63		30.0	
		Z	14.94	96.21	27.54		30.0	
10315-AAB	IEEE 802.11b WiFi 2.4 GHz (DSSS, 1 Mbps, 96pc duty cycle)	X	1.20	65.36	16.48	0.17	150.0	± 9.6 %
		Y	1.15	64.26	15.42		150.0	
		Z	1.17	64.62	15.77		150.0	
10316-AAB	IEEE 802.11g WiFi 2.4 GHz (ERP-OFDM, 6 Mbps, 96pc duty cycle)	X	4.76	67.14	16.74	0.17	150.0	± 9.6 %
		Y	4.71	66.90	16.45		150.0	
		Z	4.73	66.99	16.55		150.0	
10317-AAB	IEEE 802.11a WiFi 5 GHz (OFDM, 6 Mbps, 96pc duty cycle)	X	4.76	67.14	16.74	0.17	150.0	± 9.6 %
		Y	4.71	66.90	16.45		150.0	
		Z	4.73	66.99	16.55		150.0	
10400-AAC	IEEE 802.11ac WiFi (20MHz, 64-QAM, 99pc duty cycle)	X	4.87	67.43	16.68	0.00	150.0	± 9.6 %
		Y	4.81	67.14	16.37		150.0	
		Z	4.83	67.26	16.47		150.0	
10401-AAC	IEEE 802.11ac WiFi (40MHz, 64-QAM, 99pc duty cycle)	X	5.57	67.64	16.85	0.00	150.0	± 9.6 %
		Y	5.51	67.40	16.57		150.0	
		Z	5.53	67.48	16.66		150.0	

10402-AAC	IEEE 802.11ac WiFi (80MHz, 64-QAM, 99pc duty cycle)	X	5.83	67.94	16.82	0.00	150.0	± 9.6 %
		Y	5.77	67.71	16.58		150.0	
		Z	5.79	67.80	16.65		150.0	
10403-AAB	CDMA2000 (1xEV-DO, Rev. 0)	X	2.05	73.37	16.75	0.00	115.0	± 9.6 %
		Y	1.54	68.94	14.39		115.0	
		Z	1.68	70.29	15.17		115.0	
10404-AAB	CDMA2000 (1xEV-DO, Rev. A)	X	2.05	73.37	16.75	0.00	115.0	± 9.6 %
		Y	1.54	68.94	14.39		115.0	
		Z	1.68	70.29	15.17		115.0	
10406-AAB	CDMA2000, RC3, SO32, SCH0, Full Rate	X	100.00	124.58	31.94	0.00	100.0	± 9.6 %
		Y	100.00	121.04	30.37		100.0	
		Z	100.00	123.01	31.32		100.0	
10410-AAB	LTE-TDD (SC-FDMA, 1 RB, 10 MHz, QPSK, UL Subframe=2,3,4,7,8,9)	X	100.00	125.25	32.53	3.23	80.0	± 9.6 %
		Y	100.00	122.76	31.43		80.0	
		Z	100.00	124.49	32.22		80.0	
10415-AAA	IEEE 802.11b WiFi 2.4 GHz (DSSS, 1 Mbps, 99pc duty cycle)	X	1.07	64.01	15.66	0.00	150.0	± 9.6 %
		Y	1.03	63.00	14.62		150.0	
		Z	1.05	63.37	14.98		150.0	
10416-AAA	IEEE 802.11g WiFi 2.4 GHz (ERP-OFDM, 6 Mbps, 99pc duty cycle)	X	4.68	67.03	16.59	0.00	150.0	± 9.6 %
		Y	4.63	66.78	16.30		150.0	
		Z	4.65	66.88	16.40		150.0	
10417-AAA	IEEE 802.11a/h WiFi 5 GHz (OFDM, 6 Mbps, 99pc duty cycle)	X	4.68	67.03	16.59	0.00	150.0	± 9.6 %
		Y	4.63	66.78	16.30		150.0	
		Z	4.65	66.88	16.40		150.0	
10418-AAA	IEEE 802.11g WiFi 2.4 GHz (DSSS-OFDM, 6 Mbps, 99pc duty cycle, Long preamble)	X	4.67	67.18	16.60	0.00	150.0	± 9.6 %
		Y	4.61	66.92	16.31		150.0	
		Z	4.64	67.02	16.41		150.0	
10419-AAA	IEEE 802.11g WiFi 2.4 GHz (DSSS-OFDM, 6 Mbps, 99pc duty cycle, Short preamble)	X	4.69	67.13	16.61	0.00	150.0	± 9.6 %
		Y	4.64	66.87	16.32		150.0	
		Z	4.66	66.98	16.42		150.0	
10422-AAA	IEEE 802.11n (HT Greenfield, 7.2 Mbps, BPSK)	X	4.82	67.13	16.62	0.00	150.0	± 9.6 %
		Y	4.76	66.89	16.34		150.0	
		Z	4.78	66.98	16.43		150.0	
10423-AAA	IEEE 802.11n (HT Greenfield, 43.3 Mbps, 16-QAM)	X	5.00	67.48	16.75	0.00	150.0	± 9.6 %
		Y	4.94	67.23	16.47		150.0	
		Z	4.96	67.33	16.56		150.0	
10424-AAA	IEEE 802.11n (HT Greenfield, 72.2 Mbps, 64-QAM)	X	4.92	67.43	16.72	0.00	150.0	± 9.6 %
		Y	4.86	67.17	16.43		150.0	
		Z	4.88	67.27	16.53		150.0	
10425-AAA	IEEE 802.11n (HT Greenfield, 15 Mbps, BPSK)	X	5.54	67.85	16.94	0.00	150.0	± 9.6 %
		Y	5.48	67.60	16.67		150.0	
		Z	5.50	67.69	16.75		150.0	
10426-AAA	IEEE 802.11n (HT Greenfield, 90 Mbps, 16-QAM)	X	5.55	67.86	16.94	0.00	150.0	± 9.6 %
		Y	5.48	67.61	16.67		150.0	
		Z	5.50	67.70	16.75		150.0	

10427-AAA	IEEE 802.11n (HT Greenfield, 150 Mbps, 64-QAM)	X	5.55	67.81	16.91	0.00	150.0	± 9.6 %
		Y	5.49	67.57	16.65		150.0	
		Z	5.51	67.66	16.73		150.0	
10430-AAA	LTE-FDD (OFDMA, 5 MHz, E-TM 3.1)	X	4.30	70.44	18.21	0.00	150.0	± 9.6 %
		Y	4.27	70.38	18.04		150.0	
		Z	4.27	70.33	18.05		150.0	
10431-AAA	LTE-FDD (OFDMA, 10 MHz, E-TM 3.1)	X	4.40	67.65	16.65	0.00	150.0	± 9.6 %
		Y	4.32	67.31	16.31		150.0	
		Z	4.35	67.44	16.43		150.0	
10432-AAA	LTE-FDD (OFDMA, 15 MHz, E-TM 3.1)	X	4.69	67.49	16.69	0.00	150.0	± 9.6 %
		Y	4.62	67.20	16.38		150.0	
		Z	4.65	67.32	16.48		150.0	
10433-AAA	LTE-FDD (OFDMA, 20 MHz, E-TM 3.1)	X	4.93	67.46	16.74	0.00	150.0	± 9.6 %
		Y	4.87	67.20	16.45		150.0	
		Z	4.89	67.31	16.55		150.0	
10434-AAA	W-CDMA (BS Test Model 1, 64 DPCH)	X	4.38	71.21	18.18	0.00	150.0	± 9.6 %
		Y	4.35	71.12	17.99		150.0	
		Z	4.34	71.07	18.01		150.0	
10435-AAB	LTE-TDD (SC-FDMA, 1 RB, 20 MHz, QPSK, UL Subframe=2,3,4,7,8,9)	X	100.00	125.05	32.43	3.23	80.0	± 9.6 %
		Y	100.00	122.57	31.34		80.0	
		Z	100.00	124.29	32.13		80.0	
10447-AAA	LTE-FDD (OFDMA, 5 MHz, E-TM 3.1, Clipping 44%)	X	3.71	67.79	16.12	0.00	150.0	± 9.6 %
		Y	3.61	67.29	15.67		150.0	
		Z	3.65	67.48	15.83		150.0	
10448-AAA	LTE-FDD (OFDMA, 10 MHz, E-TM 3.1, Clipping 44%)	X	4.22	67.42	16.51	0.00	150.0	± 9.6 %
		Y	4.15	67.08	16.17		150.0	
		Z	4.18	67.21	16.28		150.0	
10449-AAA	LTE-FDD (OFDMA, 15 MHz, E-TM 3.1, Clipping 44%)	X	4.49	67.31	16.58	0.00	150.0	± 9.6 %
		Y	4.42	67.02	16.27		150.0	
		Z	4.45	67.13	16.38		150.0	
10450-AAA	LTE-FDD (OFDMA, 20 MHz, E-TM 3.1, Clipping 44%)	X	4.67	67.22	16.59	0.00	150.0	± 9.6 %
		Y	4.62	66.95	16.30		150.0	
		Z	4.64	67.06	16.40		150.0	
10451-AAA	W-CDMA (BS Test Model 1, 64 DPCH, Clipping 44%)	X	3.63	68.08	15.83	0.00	150.0	± 9.6 %
		Y	3.51	67.49	15.33		150.0	
		Z	3.56	67.71	15.51		150.0	
10456-AAA	IEEE 802.11ac WiFi (160MHz, 64-QAM, 99pc duty cycle)	X	6.40	68.36	17.05	0.00	150.0	± 9.6 %
		Y	6.34	68.15	16.82		150.0	
		Z	6.36	68.22	16.89		150.0	
10457-AAA	UMTS-FDD (DC-HSDPA)	X	3.89	65.64	16.31	0.00	150.0	± 9.6 %
		Y	3.85	65.40	16.01		150.0	
		Z	3.87	65.50	16.11		150.0	
10458-AAA	CDMA2000 (1xEV-DO, Rev. B, 2 carriers)	X	3.46	67.50	15.35	0.00	150.0	± 9.6 %
		Y	3.34	66.87	14.80		150.0	
		Z	3.39	67.11	15.01		150.0	
10459-AAA	CDMA2000 (1xEV-DO, Rev. B, 3 carriers)	X	4.52	65.47	16.05	0.00	150.0	± 9.6 %
		Y	4.52	65.47	15.86		150.0	
		Z	4.43	65.14	15.75		150.0	

10460-AAA	UMTS-FDD (WCDMA, AMR)	X	1.17	72.68	18.90	0.00	150.0	± 9.6 %
		Y	0.92	67.87	15.98		150.0	
		Z	0.99	69.33	16.91		150.0	
10461-AAA	LTE-TDD (SC-FDMA, 1 RB, 1.4 MHz, QPSK, UL Subframe=2,3,4,7,8,9)	X	100.00	132.17	35.74	3.29	80.0	± 9.6 %
		Y	100.00	128.42	34.08		80.0	
		Z	100.00	130.59	35.07		80.0	
10462-AAA	LTE-TDD (SC-FDMA, 1 RB, 1.4 MHz, 16-QAM, UL Subframe=2,3,4,7,8,9)	X	100.00	113.31	26.72	3.23	80.0	± 9.6 %
		Y	100.00	110.59	25.58		80.0	
		Z	100.00	112.57	26.48		80.0	
10463-AAA	LTE-TDD (SC-FDMA, 1 RB, 1.4 MHz, 64-QAM, UL Subframe=2,3,4,7,8,9)	X	100.00	109.35	24.86	3.23	80.0	± 9.6 %
		Y	100.00	106.97	23.86		80.0	
		Z	100.00	108.85	24.71		80.0	
10464-AAA	LTE-TDD (SC-FDMA, 1 RB, 3 MHz, QPSK, UL Subframe=2,3,4,7,8,9)	X	100.00	130.18	34.63	3.23	80.0	± 9.6 %
		Y	100.00	126.36	32.95		80.0	
		Z	100.00	128.62	33.98		80.0	
10465-AAA	LTE-TDD (SC-FDMA, 1 RB, 3 MHz, 16-QAM, UL Subframe=2,3,4,7,8,9)	X	100.00	112.71	26.43	3.23	80.0	± 9.6 %
		Y	100.00	110.00	25.29		80.0	
		Z	100.00	111.98	26.19		80.0	
10466-AAA	LTE-TDD (SC-FDMA, 1 RB, 3 MHz, 64-QAM, UL Subframe=2,3,4,7,8,9)	X	100.00	108.78	24.59	3.23	80.0	± 9.6 %
		Y	100.00	106.43	23.61		80.0	
		Z	100.00	108.29	24.45		80.0	
10467-AAB	LTE-TDD (SC-FDMA, 1 RB, 5 MHz, QPSK, UL Subframe=2,3,4,7,8,9)	X	100.00	130.44	34.75	3.23	80.0	± 9.6 %
		Y	100.00	126.60	33.07		80.0	
		Z	100.00	128.86	34.09		80.0	
10468-AAB	LTE-TDD (SC-FDMA, 1 RB, 5 MHz, 16-QAM, UL Subframe=2,3,4,7,8,9)	X	100.00	112.91	26.52	3.23	80.0	± 9.6 %
		Y	100.00	110.19	25.38		80.0	
		Z	100.00	112.17	26.28		80.0	
10469-AAB	LTE-TDD (SC-FDMA, 1 RB, 5 MHz, 64-QAM, UL Subframe=2,3,4,7,8,9)	X	100.00	108.81	24.59	3.23	80.0	± 9.6 %
		Y	100.00	106.45	23.61		80.0	
		Z	100.00	108.32	24.46		80.0	
10470-AAB	LTE-TDD (SC-FDMA, 1 RB, 10 MHz, QPSK, UL Subframe=2,3,4,7,8,9)	X	100.00	130.49	34.76	3.23	80.0	± 9.6 %
		Y	100.00	126.64	33.07		80.0	
		Z	100.00	128.91	34.11		80.0	
10471-AAB	LTE-TDD (SC-FDMA, 1 RB, 10 MHz, 16-QAM, UL Subframe=2,3,4,7,8,9)	X	100.00	112.85	26.49	3.23	80.0	± 9.6 %
		Y	100.00	110.13	25.35		80.0	
		Z	100.00	112.12	26.25		80.0	
10472-AAB	LTE-TDD (SC-FDMA, 1 RB, 10 MHz, 64-QAM, UL Subframe=2,3,4,7,8,9)	X	100.00	108.74	24.56	3.23	80.0	± 9.6 %
		Y	100.00	106.39	23.57		80.0	
		Z	100.00	108.26	24.42		80.0	
10473-AAB	LTE-TDD (SC-FDMA, 1 RB, 15 MHz, QPSK, UL Subframe=2,3,4,7,8,9)	X	100.00	130.46	34.75	3.23	80.0	± 9.6 %
		Y	100.00	126.61	33.06		80.0	
		Z	100.00	128.88	34.09		80.0	
10474-AAB	LTE-TDD (SC-FDMA, 1 RB, 15 MHz, 16-QAM, UL Subframe=2,3,4,7,8,9)	X	100.00	112.87	26.49	3.23	80.0	± 9.6 %
		Y	100.00	110.14	25.35		80.0	
		Z	100.00	112.13	26.25		80.0	
10475-AAB	LTE-TDD (SC-FDMA, 1 RB, 15 MHz, 64-QAM, UL Subframe=2,3,4,7,8,9)	X	100.00	108.76	24.57	3.23	80.0	± 9.6 %
		Y	100.00	106.40	23.58		80.0	
		Z	100.00	108.28	24.43		80.0	

10477-AAB	LTE-TDD (SC-FDMA, 1 RB, 20 MHz, 16-QAM, UL Subframe=2,3,4,7,8,9)	X	100.00	112.67	26.40	3.23	80.0	± 9.6 %
		Y	100.00	109.96	25.26		80.0	
		Z	100.00	111.94	26.16		80.0	
10478-AAB	LTE-TDD (SC-FDMA, 1 RB, 20 MHz, 64-QAM, UL Subframe=2,3,4,7,8,9)	X	100.00	108.69	24.54	3.23	80.0	± 9.6 %
		Y	100.00	106.34	23.55		80.0	
		Z	100.00	108.21	24.40		80.0	
10479-AAA	LTE-TDD (SC-FDMA, 50% RB, 1.4 MHz, QPSK, UL Subframe=2,3,4,7,8,9)	X	40.01	113.99	32.23	3.23	80.0	± 9.6 %
		Y	25.66	104.98	29.34		80.0	
		Z	28.59	107.69	30.37		80.0	
10480-AAA	LTE-TDD (SC-FDMA, 50% RB, 1.4 MHz, 16-QAM, UL Subframe=2,3,4,7,8,9)	X	65.50	112.78	29.57	3.23	80.0	± 9.6 %
		Y	38.67	103.69	26.87		80.0	
		Z	45.46	106.90	27.97		80.0	
10481-AAA	LTE-TDD (SC-FDMA, 50% RB, 1.4 MHz, 64-QAM, UL Subframe=2,3,4,7,8,9)	X	43.66	105.54	27.32	3.23	80.0	± 9.6 %
		Y	27.51	97.77	24.89		80.0	
		Z	32.53	100.89	25.98		80.0	
10482-AAA	LTE-TDD (SC-FDMA, 50% RB, 3 MHz, QPSK, UL Subframe=2,3,4,7,8,9)	X	7.07	83.64	21.75	2.23	80.0	± 9.6 %
		Y	5.28	78.63	19.68		80.0	
		Z	5.64	80.01	20.31		80.0	
10483-AAA	LTE-TDD (SC-FDMA, 50% RB, 3 MHz, 16-QAM, UL Subframe=2,3,4,7,8,9)	X	12.44	88.49	23.12	2.23	80.0	± 9.6 %
		Y	10.70	85.40	21.78		80.0	
		Z	11.46	86.94	22.49		80.0	
10484-AAA	LTE-TDD (SC-FDMA, 50% RB, 3 MHz, 64-QAM, UL Subframe=2,3,4,7,8,9)	X	10.60	85.91	22.30	2.23	80.0	± 9.6 %
		Y	9.30	83.19	21.06		80.0	
		Z	9.88	84.56	21.72		80.0	
10485-AAB	LTE-TDD (SC-FDMA, 50% RB, 5 MHz, QPSK, UL Subframe=2,3,4,7,8,9)	X	6.73	83.37	22.54	2.23	80.0	± 9.6 %
		Y	5.38	79.13	20.71		80.0	
		Z	5.62	80.23	21.24		80.0	
10486-AAB	LTE-TDD (SC-FDMA, 50% RB, 5 MHz, 16-QAM, UL Subframe=2,3,4,7,8,9)	X	4.83	74.76	18.90	2.23	80.0	± 9.6 %
		Y	4.43	72.99	17.93		80.0	
		Z	4.49	73.45	18.22		80.0	
10487-AAB	LTE-TDD (SC-FDMA, 50% RB, 5 MHz, 64-QAM, UL Subframe=2,3,4,7,8,9)	X	4.73	74.06	18.61	2.23	80.0	± 9.6 %
		Y	4.38	72.45	17.70		80.0	
		Z	4.42	72.86	17.97		80.0	
10488-AAB	LTE-TDD (SC-FDMA, 50% RB, 10 MHz, QPSK, UL Subframe=2,3,4,7,8,9)	X	5.94	79.74	21.83	2.23	80.0	± 9.6 %
		Y	5.18	76.93	20.48		80.0	
		Z	5.31	77.65	20.88		80.0	
10489-AAB	LTE-TDD (SC-FDMA, 50% RB, 10 MHz, 16-QAM, UL Subframe=2,3,4,7,8,9)	X	4.65	72.93	19.25	2.23	80.0	± 9.6 %
		Y	4.44	71.79	18.53		80.0	
		Z	4.45	72.03	18.73		80.0	
10490-AAB	LTE-TDD (SC-FDMA, 50% RB, 10 MHz, 64-QAM, UL Subframe=2,3,4,7,8,9)	X	4.70	72.53	19.10	2.23	80.0	± 9.6 %
		Y	4.51	71.49	18.42		80.0	
		Z	4.51	71.71	18.61		80.0	
10491-AAB	LTE-TDD (SC-FDMA, 50% RB, 15 MHz, QPSK, UL Subframe=2,3,4,7,8,9)	X	5.47	76.11	20.55	2.23	80.0	± 9.6 %
		Y	5.05	74.35	19.60		80.0	
		Z	5.11	74.80	19.88		80.0	
10492-AAB	LTE-TDD (SC-FDMA, 50% RB, 15 MHz, 16-QAM, UL Subframe=2,3,4,7,8,9)	X	4.82	71.43	18.89	2.23	80.0	± 9.6 %
		Y	4.68	70.61	18.31		80.0	
		Z	4.67	70.78	18.47		80.0	



10493-AAB	LTE-TDD (SC-FDMA, 50% RB, 15 MHz, 64-QAM, UL Subframe=2,3,4,7,8,9)	X	4.87	71.19	18.80	2.23	80.0	± 9.6 %
		Y	4.73	70.41	18.24		80.0	
		Z	4.72	70.57	18.39		80.0	
10494-AAB	LTE-TDD (SC-FDMA, 50% RB, 20 MHz, QPSK, UL Subframe=2,3,4,7,8,9)	X	6.24	78.41	21.24	2.23	80.0	± 9.6 %
		Y	5.62	76.22	20.16		80.0	
		Z	5.73	76.81	20.48		80.0	
10495-AAB	LTE-TDD (SC-FDMA, 50% RB, 20 MHz, 16-QAM, UL Subframe=2,3,4,7,8,9)	X	4.91	72.01	19.14	2.23	80.0	± 9.6 %
		Y	4.75	71.11	18.53		80.0	
		Z	4.74	71.30	18.69		80.0	
10496-AAB	LTE-TDD (SC-FDMA, 50% RB, 20 MHz, 64-QAM, UL Subframe=2,3,4,7,8,9)	X	4.93	71.51	18.96	2.23	80.0	± 9.6 %
		Y	4.79	70.71	18.40		80.0	
		Z	4.78	70.87	18.55		80.0	
10497-AAA	LTE-TDD (SC-FDMA, 100% RB, 1.4 MHz, QPSK, UL Subframe=2,3,4,7,8,9)	X	5.37	79.10	19.27	2.23	80.0	± 9.6 %
		Y	4.01	74.46	17.26		80.0	
		Z	4.32	75.84	17.92		80.0	
10498-AAA	LTE-TDD (SC-FDMA, 100% RB, 1.4 MHz, 16-QAM, UL Subframe=2,3,4,7,8,9)	X	3.20	69.04	14.31	2.23	80.0	± 9.6 %
		Y	2.73	66.72	13.06		80.0	
		Z	2.85	67.49	13.50		80.0	
10499-AAA	LTE-TDD (SC-FDMA, 100% RB, 1.4 MHz, 64-QAM, UL Subframe=2,3,4,7,8,9)	X	3.04	68.09	13.76	2.23	80.0	± 9.6 %
		Y	2.62	65.95	12.57		80.0	
		Z	2.73	66.66	12.99		80.0	
10500-AAA	LTE-TDD (SC-FDMA, 100% RB, 3 MHz, QPSK, UL Subframe=2,3,4,7,8,9)	X	6.09	81.07	21.99	2.23	80.0	± 9.6 %
		Y	5.13	77.67	20.43		80.0	
		Z	5.29	78.55	20.89		80.0	
10501-AAA	LTE-TDD (SC-FDMA, 100% RB, 3 MHz, 16-QAM, UL Subframe=2,3,4,7,8,9)	X	4.73	73.89	18.97	2.23	80.0	± 9.6 %
		Y	4.43	72.44	18.13		80.0	
		Z	4.46	72.79	18.37		80.0	
10502-AAA	LTE-TDD (SC-FDMA, 100% RB, 3 MHz, 64-QAM, UL Subframe=2,3,4,7,8,9)	X	4.76	73.56	18.78	2.23	80.0	± 9.6 %
		Y	4.47	72.19	17.97		80.0	
		Z	4.49	72.52	18.21		80.0	
10503-AAB	LTE-TDD (SC-FDMA, 100% RB, 5 MHz, QPSK, UL Subframe=2,3,4,7,8,9)	X	5.85	79.51	21.73	2.23	80.0	± 9.6 %
		Y	5.11	76.71	20.38		80.0	
		Z	5.24	77.44	20.78		80.0	
10504-AAB	LTE-TDD (SC-FDMA, 100% RB, 5 MHz, 16-QAM, UL Subframe=2,3,4,7,8,9)	X	4.63	72.85	19.20	2.23	80.0	± 9.6 %
		Y	4.42	71.70	18.48		80.0	
		Z	4.43	71.95	18.68		80.0	
10505-AAB	LTE-TDD (SC-FDMA, 100% RB, 5 MHz, 64-QAM, UL Subframe=2,3,4,7,8,9)	X	4.68	72.44	19.05	2.23	80.0	± 9.6 %
		Y	4.49	71.39	18.37		80.0	
		Z	4.49	71.62	18.56		80.0	
10506-AAB	LTE-TDD (SC-FDMA, 100% RB, 10 MHz, QPSK, UL Subframe=2,3,4,7,8,9)	X	6.19	78.25	21.17	2.23	80.0	± 9.6 %
		Y	5.58	76.07	20.08		80.0	
		Z	5.68	76.66	20.41		80.0	
10507-AAB	LTE-TDD (SC-FDMA, 100% RB, 10 MHz, 16-QAM, UL Subframe=2,3,4,7,8,9)	X	4.89	71.95	19.11	2.23	80.0	± 9.6 %
		Y	4.73	71.04	18.50		80.0	
		Z	4.73	71.24	18.66		80.0	

10508-AAB	LTE-TDD (SC-FDMA, 100% RB, 10 MHz, 64-QAM, UL Subframe=2,3,4,7,8,9)	X	4.92	71.45	18.93	2.23	80.0	± 9.6 %
		Y	4.78	70.64	18.36		80.0	
		Z	4.77	70.80	18.51		80.0	
10509-AAB	LTE-TDD (SC-FDMA, 100% RB, 15 MHz, QPSK, UL Subframe=2,3,4,7,8,9)	X	5.95	75.24	19.99	2.23	80.0	± 9.6 %
		Y	5.60	73.90	19.24		80.0	
		Z	5.65	74.26	19.47		80.0	
10510-AAB	LTE-TDD (SC-FDMA, 100% RB, 15 MHz, 16-QAM, UL Subframe=2,3,4,7,8,9)	X	5.29	71.15	18.83	2.23	80.0	± 9.6 %
		Y	5.16	70.46	18.33		80.0	
		Z	5.15	70.61	18.47		80.0	
10511-AAB	LTE-TDD (SC-FDMA, 100% RB, 15 MHz, 64-QAM, UL Subframe=2,3,4,7,8,9)	X	5.30	70.75	18.70	2.23	80.0	± 9.6 %
		Y	5.19	70.12	18.23		80.0	
		Z	5.17	70.25	18.36		80.0	
10512-AAB	LTE-TDD (SC-FDMA, 100% RB, 20 MHz, QPSK, UL Subframe=2,3,4,7,8,9)	X	6.65	77.81	20.82	2.23	80.0	± 9.6 %
		Y	6.08	75.94	19.88		80.0	
		Z	6.18	76.48	20.17		80.0	
10513-AAB	LTE-TDD (SC-FDMA, 100% RB, 20 MHz, 16-QAM, UL Subframe=2,3,4,7,8,9)	X	5.24	71.68	19.04	2.23	80.0	± 9.6 %
		Y	5.09	70.89	18.50		80.0	
		Z	5.08	71.06	18.65		80.0	
10514-AAB	LTE-TDD (SC-FDMA, 100% RB, 20 MHz, 64-QAM, UL Subframe=2,3,4,7,8,9)	X	5.18	71.04	18.83	2.23	80.0	± 9.6 %
		Y	5.06	70.34	18.33		80.0	
		Z	5.05	70.49	18.47		80.0	
10515-AAA	IEEE 802.11b WiFi 2.4 GHz (DSSS, 2 Mbps, 99pc duty cycle)	X	1.04	64.30	15.79	0.00	150.0	± 9.6 %
		Y	1.00	63.17	14.68		150.0	
		Z	1.01	63.58	15.06		150.0	
10516-AAA	IEEE 802.11b WiFi 2.4 GHz (DSSS, 5.5 Mbps, 99pc duty cycle)	X	1.17	82.68	23.48	0.00	150.0	± 9.6 %
		Y	0.61	69.65	16.88		150.0	
		Z	0.72	72.79	18.69		150.0	
10517-AAA	IEEE 802.11b WiFi 2.4 GHz (DSSS, 11 Mbps, 99pc duty cycle)	X	0.94	67.44	17.14	0.00	150.0	± 9.6 %
		Y	0.85	65.01	15.25		150.0	
		Z	0.88	65.81	15.88		150.0	
10518-AAA	IEEE 802.11a/h WiFi 5 GHz (OFDM, 9 Mbps, 99pc duty cycle)	X	4.68	67.10	16.57	0.00	150.0	± 9.6 %
		Y	4.62	66.85	16.28		150.0	
		Z	4.64	66.95	16.38		150.0	
10519-AAA	IEEE 802.11a/h WiFi 5 GHz (OFDM, 12 Mbps, 99pc duty cycle)	X	4.88	67.37	16.70	0.00	150.0	± 9.6 %
		Y	4.82	67.11	16.42		150.0	
		Z	4.84	67.21	16.51		150.0	
10520-AAA	IEEE 802.11a/h WiFi 5 GHz (OFDM, 18 Mbps, 99pc duty cycle)	X	4.73	67.35	16.63	0.00	150.0	± 9.6 %
		Y	4.67	67.07	16.33		150.0	
		Z	4.69	67.18	16.43		150.0	
10521-AAA	IEEE 802.11a/h WiFi 5 GHz (OFDM, 24 Mbps, 99pc duty cycle)	X	4.66	67.35	16.62	0.00	150.0	± 9.6 %
		Y	4.60	67.06	16.32		150.0	
		Z	4.62	67.17	16.42		150.0	
10522-AAA	IEEE 802.11a/h WiFi 5 GHz (OFDM, 36 Mbps, 99pc duty cycle)	X	4.72	67.40	16.69	0.00	150.0	± 9.6 %
		Y	4.66	67.13	16.39		150.0	
		Z	4.68	67.24	16.49		150.0	

10523-AAA	IEEE 802.11a/h WiFi 5 GHz (OFDM, 48 Mbps, 99pc duty cycle)	X	4.59	67.26	16.53	0.00	150.0	± 9.6 %
		Y	4.53	66.98	16.23		150.0	
		Z	4.55	67.09	16.33		150.0	
10524-AAA	IEEE 802.11a/h WiFi 5 GHz (OFDM, 54 Mbps, 99pc duty cycle)	X	4.66	67.34	16.66	0.00	150.0	± 9.6 %
		Y	4.60	67.06	16.36		150.0	
		Z	4.63	67.17	16.46		150.0	
10525-AAA	IEEE 802.11ac WiFi (20MHz, MCS0, 99pc duty cycle)	X	4.64	66.35	16.23	0.00	150.0	± 9.6 %
		Y	4.58	66.08	15.94		150.0	
		Z	4.60	66.19	16.04		150.0	
10526-AAA	IEEE 802.11ac WiFi (20MHz, MCS1, 99pc duty cycle)	X	4.82	66.75	16.38	0.00	150.0	± 9.6 %
		Y	4.76	66.47	16.09		150.0	
		Z	4.78	66.58	16.19		150.0	
10527-AAA	IEEE 802.11ac WiFi (20MHz, MCS2, 99pc duty cycle)	X	4.74	66.71	16.33	0.00	150.0	± 9.6 %
		Y	4.68	66.42	16.03		150.0	
		Z	4.70	66.54	16.13		150.0	
10528-AAA	IEEE 802.11ac WiFi (20MHz, MCS3, 99pc duty cycle)	X	4.76	66.73	16.36	0.00	150.0	± 9.6 %
		Y	4.69	66.44	16.07		150.0	
		Z	4.72	66.56	16.17		150.0	
10529-AAA	IEEE 802.11ac WiFi (20MHz, MCS4, 99pc duty cycle)	X	4.76	66.73	16.36	0.00	150.0	± 9.6 %
		Y	4.69	66.44	16.07		150.0	
		Z	4.72	66.56	16.17		150.0	
10531-AAA	IEEE 802.11ac WiFi (20MHz, MCS6, 99pc duty cycle)	X	4.76	66.87	16.39	0.00	150.0	± 9.6 %
		Y	4.69	66.56	16.08		150.0	
		Z	4.72	66.68	16.19		150.0	
10532-AAA	IEEE 802.11ac WiFi (20MHz, MCS7, 99pc duty cycle)	X	4.62	66.72	16.33	0.00	150.0	± 9.6 %
		Y	4.55	66.41	16.02		150.0	
		Z	4.57	66.53	16.12		150.0	
10533-AAA	IEEE 802.11ac WiFi (20MHz, MCS8, 99pc duty cycle)	X	4.77	66.77	16.35	0.00	150.0	± 9.6 %
		Y	4.70	66.48	16.05		150.0	
		Z	4.73	66.80	16.15		150.0	
10534-AAA	IEEE 802.11ac WiFi (40MHz, MCS0, 99pc duty cycle)	X	5.29	66.84	16.41	0.00	150.0	± 9.6 %
		Y	5.23	66.60	16.14		150.0	
		Z	5.25	66.69	16.23		150.0	
10535-AAA	IEEE 802.11ac WiFi (40MHz, MCS1, 99pc duty cycle)	X	5.37	67.02	16.49	0.00	150.0	± 9.6 %
		Y	5.30	66.78	16.22		150.0	
		Z	5.32	66.87	16.31		150.0	
10536-AAA	IEEE 802.11ac WiFi (40MHz, MCS2, 99pc duty cycle)	X	5.23	66.97	16.44	0.00	150.0	± 9.6 %
		Y	5.17	66.72	16.17		150.0	
		Z	5.19	66.82	16.26		150.0	
10537-AAA	IEEE 802.11ac WiFi (40MHz, MCS3, 99pc duty cycle)	X	5.29	66.95	16.43	0.00	150.0	± 9.6 %
		Y	5.23	66.69	16.17		150.0	
		Z	5.25	66.79	16.25		150.0	
10538-AAA	IEEE 802.11ac WiFi (40MHz, MCS4, 99pc duty cycle)	X	5.39	66.99	16.50	0.00	150.0	± 9.6 %
		Y	5.33	66.74	16.23		150.0	
		Z	5.35	66.84	16.31		150.0	
10540-AAA	IEEE 802.11ac WiFi (40MHz, MCS6, 99pc duty cycle)	X	5.32	66.99	16.51	0.00	150.0	± 9.6 %
		Y	5.25	66.74	16.24		150.0	
		Z	5.27	66.83	16.33		150.0	

10541-AAA	IEEE 802.11ac WiFi (40MHz, MCS7, 99pc duty cycle)	X	5.28	66.83	16.43	0.00	150.0	± 9.6 %
		Y	5.22	66.59	16.16		150.0	
		Z	5.24	66.69	16.25		150.0	
10542-AAA	IEEE 802.11ac WiFi (40MHz, MCS8, 99pc duty cycle)	X	5.44	66.91	16.48	0.00	150.0	± 9.6 %
		Y	5.38	66.68	16.22		150.0	
		Z	5.40	66.77	16.30		150.0	
10543-AAA	IEEE 802.11ac WiFi (40MHz, MCS9, 99pc duty cycle)	X	5.53	66.97	16.53	0.00	150.0	± 9.6 %
		Y	5.47	66.73	16.27		150.0	
		Z	5.49	66.82	16.35		150.0	
10544-AAA	IEEE 802.11ac WiFi (80MHz, MCS0, 99pc duty cycle)	X	5.59	66.91	16.37	0.00	150.0	± 9.6 %
		Y	5.53	66.70	16.13		150.0	
		Z	5.55	66.79	16.21		150.0	
10545-AAA	IEEE 802.11ac WiFi (80MHz, MCS1, 99pc duty cycle)	X	5.82	67.42	16.57	0.00	150.0	± 9.6 %
		Y	5.75	67.17	16.32		150.0	
		Z	5.77	67.26	16.40		150.0	
10546-AAA	IEEE 802.11ac WiFi (80MHz, MCS2, 99pc duty cycle)	X	5.68	67.19	16.48	0.00	150.0	± 9.6 %
		Y	5.61	66.95	16.22		150.0	
		Z	5.64	67.05	16.30		150.0	
10547-AAA	IEEE 802.11ac WiFi (80MHz, MCS3, 99pc duty cycle)	X	5.77	67.28	16.51	0.00	150.0	± 9.6 %
		Y	5.70	67.03	16.25		150.0	
		Z	5.72	67.12	16.33		150.0	
10548-AAA	IEEE 802.11ac WiFi (80MHz, MCS4, 99pc duty cycle)	X	6.16	68.66	17.18	0.00	150.0	± 9.6 %
		Y	6.05	68.25	16.83		150.0	
		Z	6.07	68.36	16.93		150.0	
10550-AAA	IEEE 802.11ac WiFi (80MHz, MCS6, 99pc duty cycle)	X	5.70	67.18	16.48	0.00	150.0	± 9.6 %
		Y	5.64	66.95	16.23		150.0	
		Z	5.66	67.04	16.31		150.0	
10551-AAA	IEEE 802.11ac WiFi (80MHz, MCS7, 99pc duty cycle)	X	5.70	67.20	16.45	0.00	150.0	± 9.6 %
		Y	5.64	66.98	16.21		150.0	
		Z	5.66	67.07	16.28		150.0	
10552-AAA	IEEE 802.11ac WiFi (80MHz, MCS8, 99pc duty cycle)	X	5.60	66.97	16.34	0.00	150.0	± 9.6 %
		Y	5.55	66.76	16.11		150.0	
		Z	5.57	66.85	16.18		150.0	
10553-AAA	IEEE 802.11ac WiFi (80MHz, MCS9, 99pc duty cycle)	X	5.69	67.02	16.40	0.00	150.0	± 9.6 %
		Y	5.64	66.81	16.16		150.0	
		Z	5.66	66.90	16.24		150.0	
10554-AAA	IEEE 1602.11ac WiFi (160MHz, MCS0, 99pc duty cycle)	X	6.00	67.29	16.47	0.00	150.0	± 9.6 %
		Y	5.95	67.09	16.23		150.0	
		Z	5.96	67.17	16.31		150.0	
10555-AAA	IEEE 1602.11ac WiFi (160MHz, MCS1, 99pc duty cycle)	X	6.15	67.65	16.62	0.00	150.0	± 9.6 %
		Y	6.09	67.42	16.38		150.0	
		Z	6.11	67.51	16.45		150.0	
10556-AAA	IEEE 1602.11ac WiFi (160MHz, MCS2, 99pc duty cycle)	X	6.17	67.68	16.63	0.00	150.0	± 9.6 %
		Y	6.11	67.45	16.39		150.0	
		Z	6.13	67.54	16.46		150.0	
10557-AAA	IEEE 1602.11ac WiFi (160MHz, MCS3, 99pc duty cycle)	X	6.14	67.59	16.60	0.00	150.0	± 9.6 %
		Y	6.07	67.36	16.36		150.0	
		Z	6.09	67.45	16.44		150.0	

10558-AAA	IEEE 1602.11ac WiFi (160MHz, MCS4, 99pc duty cycle)	X	6.20	67.79	16.72	0.00	150.0	± 9.6 %
		Y	6.13	67.55	16.47		150.0	
		Z	6.15	67.64	16.55		150.0	
10560-AAA	IEEE 1602.11ac WiFi (160MHz, MCS6, 99pc duty cycle)	X	6.18	67.59	16.66	0.00	150.0	± 9.6 %
		Y	6.11	67.37	16.42		150.0	
		Z	6.14	67.46	16.49		150.0	
10561-AAA	IEEE 1602.11ac WiFi (160MHz, MCS7, 99pc duty cycle)	X	6.10	67.58	16.69	0.00	150.0	± 9.6 %
		Y	6.04	67.35	16.45		150.0	
		Z	6.06	67.44	16.52		150.0	
10562-AAA	IEEE 1602.11ac WiFi (160MHz, MCS8, 99pc duty cycle)	X	6.27	68.10	16.96	0.00	150.0	± 9.6 %
		Y	6.19	67.81	16.68		150.0	
		Z	6.21	67.92	16.77		150.0	
10563-AAA	IEEE 1602.11ac WiFi (160MHz, MCS9, 99pc duty cycle)	X	6.68	68.88	17.30	0.00	150.0	± 9.6 %
		Y	6.56	68.48	16.97		150.0	
		Z	6.59	68.61	17.07		150.0	
10564-AAA	IEEE 802.11g WiFi 2.4 GHz (DSSS-OFDM, 9 Mbps, 99pc duty cycle)	X	5.02	67.23	16.76	0.46	150.0	± 9.6 %
		Y	4.96	66.98	16.48		150.0	
		Z	4.98	67.08	16.57		150.0	
10565-AAA	IEEE 802.11g WiFi 2.4 GHz (DSSS-OFDM, 12 Mbps, 99pc duty cycle)	X	5.26	67.67	17.06	0.46	150.0	± 9.6 %
		Y	5.20	67.43	16.79		150.0	
		Z	5.22	67.52	16.88		150.0	
10566-AAA	IEEE 802.11g WiFi 2.4 GHz (DSSS-OFDM, 18 Mbps, 99pc duty cycle)	X	5.09	67.55	16.90	0.46	150.0	± 9.6 %
		Y	5.03	67.29	16.62		150.0	
		Z	5.05	67.39	16.71		150.0	
10567-AAA	IEEE 802.11g WiFi 2.4 GHz (DSSS-OFDM, 24 Mbps, 99pc duty cycle)	X	5.11	67.86	17.20	0.46	150.0	± 9.6 %
		Y	5.05	67.64	16.94		150.0	
		Z	5.07	67.72	17.02		150.0	
10568-AAA	IEEE 802.11g WiFi 2.4 GHz (DSSS-OFDM, 36 Mbps, 99pc duty cycle)	X	5.02	67.38	16.73	0.46	150.0	± 9.6 %
		Y	4.95	67.09	16.41		150.0	
		Z	4.98	67.21	16.52		150.0	
10569-AAA	IEEE 802.11g WiFi 2.4 GHz (DSSS-OFDM, 48 Mbps, 99pc duty cycle)	X	5.05	67.90	17.23	0.46	150.0	± 9.6 %
		Y	5.00	67.70	16.99		150.0	
		Z	5.02	67.78	17.06		150.0	
10570-AAA	IEEE 802.11g WiFi 2.4 GHz (DSSS-OFDM, 54 Mbps, 99pc duty cycle)	X	5.10	67.80	17.20	0.46	150.0	± 9.6 %
		Y	5.05	67.57	16.93		150.0	
		Z	5.07	67.66	17.02		150.0	
10571-AAA	IEEE 802.11b WiFi 2.4 GHz (DSSS, 1 Mbps, 90pc duty cycle)	X	1.35	66.69	17.17	0.46	130.0	± 9.6 %
		Y	1.30	65.45	16.06		130.0	
		Z	1.31	65.81	16.41		130.0	
10572-AAA	IEEE 802.11b WiFi 2.4 GHz (DSSS, 2 Mbps, 90pc duty cycle)	X	1.38	67.41	17.59	0.46	130.0	± 9.6 %
		Y	1.32	66.05	16.42		130.0	
		Z	1.33	66.44	16.78		130.0	
10573-AAA	IEEE 802.11b WiFi 2.4 GHz (DSSS, 5.5 Mbps, 90pc duty cycle)	X	100.00	151.66	41.18	0.46	130.0	± 9.6 %
		Y	3.17	90.18	24.53		130.0	
		Z	5.56	100.47	28.08		130.0	
10574-AAA	IEEE 802.11b WiFi 2.4 GHz (DSSS, 11 Mbps, 90pc duty cycle)	X	1.74	75.66	21.49	0.46	130.0	± 9.6 %
		Y	1.50	72.10	19.33		130.0	
		Z	1.55	73.02	19.95		130.0	

10575-AAA	IEEE 802.11g WiFi 2.4 GHz (DSSS-OFDM, 6 Mbps, 90pc duty cycle)	X	4.81	67.07	16.85	0.46	130.0	± 9.6 %
		Y	4.77	66.83	16.57		130.0	
		Z	4.78	66.92	16.66		130.0	
10576-AAA	IEEE 802.11g WiFi 2.4 GHz (DSSS-OFDM, 9 Mbps, 90pc duty cycle)	X	4.84	67.21	16.90	0.46	130.0	± 9.6 %
		Y	4.79	66.98	16.63		130.0	
		Z	4.81	67.07	16.71		130.0	
10577-AAA	IEEE 802.11g WiFi 2.4 GHz (DSSS-OFDM, 12 Mbps, 90pc duty cycle)	X	5.05	67.51	17.07	0.46	130.0	± 9.6 %
		Y	5.00	67.28	16.80		130.0	
		Z	5.02	67.37	16.88		130.0	
10578-AAA	IEEE 802.11g WiFi 2.4 GHz (DSSS-OFDM, 18 Mbps, 90pc duty cycle)	X	4.95	67.65	17.15	0.46	130.0	± 9.6 %
		Y	4.90	67.43	16.89		130.0	
		Z	4.91	67.51	16.97		130.0	
10579-AAA	IEEE 802.11g WiFi 2.4 GHz (DSSS-OFDM, 24 Mbps, 90pc duty cycle)	X	4.73	67.10	16.58	0.46	130.0	± 9.6 %
		Y	4.67	66.80	16.26		130.0	
		Z	4.70	66.92	16.37		130.0	
10580-AAA	IEEE 802.11g WiFi 2.4 GHz (DSSS-OFDM, 36 Mbps, 90pc duty cycle)	X	4.79	67.13	16.61	0.46	130.0	± 9.6 %
		Y	4.72	66.82	16.27		130.0	
		Z	4.74	66.95	16.39		130.0	
10581-AAA	IEEE 802.11g WiFi 2.4 GHz (DSSS-OFDM, 48 Mbps, 90pc duty cycle)	X	4.85	67.72	17.11	0.46	130.0	± 9.6 %
		Y	4.80	67.49	16.84		130.0	
		Z	4.81	67.57	16.92		130.0	
10582-AAA	IEEE 802.11g WiFi 2.4 GHz (DSSS-OFDM, 54 Mbps, 90pc duty cycle)	X	4.69	66.92	16.42	0.46	130.0	± 9.6 %
		Y	4.62	66.58	16.06		130.0	
		Z	4.65	66.72	16.19		130.0	
10583-AAA	IEEE 802.11a/h WiFi 5 GHz (OFDM, 6 Mbps, 90pc duty cycle)	X	4.81	67.07	16.85	0.46	130.0	± 9.6 %
		Y	4.77	66.83	16.57		130.0	
		Z	4.78	66.92	16.66		130.0	
10584-AAA	IEEE 802.11a/h WiFi 5 GHz (OFDM, 9 Mbps, 90pc duty cycle)	X	4.84	67.21	16.90	0.46	130.0	± 9.6 %
		Y	4.79	66.98	16.63		130.0	
		Z	4.81	67.07	16.71		130.0	
10585-AAA	IEEE 802.11a/h WiFi 5 GHz (OFDM, 12 Mbps, 90pc duty cycle)	X	5.05	67.51	17.07	0.46	130.0	± 9.6 %
		Y	5.00	67.28	16.80		130.0	
		Z	5.02	67.37	16.88		130.0	
10586-AAA	IEEE 802.11a/h WiFi 5 GHz (OFDM, 18 Mbps, 90pc duty cycle)	X	4.95	67.65	17.15	0.46	130.0	± 9.6 %
		Y	4.90	67.43	16.89		130.0	
		Z	4.91	67.51	16.97		130.0	
10587-AAA	IEEE 802.11a/h WiFi 5 GHz (OFDM, 24 Mbps, 90pc duty cycle)	X	4.73	67.10	16.58	0.46	130.0	± 9.6 %
		Y	4.67	66.80	16.26		130.0	
		Z	4.70	66.92	16.37		130.0	
10588-AAA	IEEE 802.11a/h WiFi 5 GHz (OFDM, 36 Mbps, 90pc duty cycle)	X	4.79	67.13	16.61	0.46	130.0	± 9.6 %
		Y	4.72	66.82	16.27		130.0	
		Z	4.74	66.95	16.39		130.0	
10589-AAA	IEEE 802.11a/h WiFi 5 GHz (OFDM, 48 Mbps, 90pc duty cycle)	X	4.85	67.72	17.11	0.46	130.0	± 9.6 %
		Y	4.80	67.49	16.84		130.0	
		Z	4.81	67.57	16.92		130.0	
10590-AAA	IEEE 802.11a/h WiFi 5 GHz (OFDM, 54 Mbps, 90pc duty cycle)	X	4.69	66.92	16.42	0.46	130.0	± 9.6 %
		Y	4.62	66.58	16.06		130.0	
		Z	4.65	66.72	16.19		130.0	

10591-AAA	IEEE 802.11n (HT Mixed, 20MHz, MCS0, 90pc duty cycle)	X	4.96	67.09	16.93	0.46	130.0	± 9.6 %
		Y	4.92	66.88	16.66		130.0	
		Z	4.93	66.96	16.75		130.0	
10592-AAA	IEEE 802.11n (HT Mixed, 20MHz, MCS1, 90pc duty cycle)	X	5.13	67.44	17.05	0.46	130.0	± 9.6 %
		Y	5.08	67.22	16.79		130.0	
		Z	5.09	67.30	16.87		130.0	
10593-AAA	IEEE 802.11n (HT Mixed, 20MHz, MCS2, 90pc duty cycle)	X	5.05	67.38	16.96	0.46	130.0	± 9.6 %
		Y	5.00	67.15	16.69		130.0	
		Z	5.02	67.24	16.77		130.0	
10594-AAA	IEEE 802.11n (HT Mixed, 20MHz, MCS3, 90pc duty cycle)	X	5.10	67.52	17.09	0.46	130.0	± 9.6 %
		Y	5.05	67.30	16.83		130.0	
		Z	5.07	67.38	16.91		130.0	
10595-AAA	IEEE 802.11n (HT Mixed, 20MHz, MCS4, 90pc duty cycle)	X	5.08	67.50	17.01	0.46	130.0	± 9.6 %
		Y	5.02	67.26	16.73		130.0	
		Z	5.04	67.35	16.82		130.0	
10596-AAA	IEEE 802.11n (HT Mixed, 20MHz, MCS5, 90pc duty cycle)	X	5.02	67.52	17.02	0.46	130.0	± 9.6 %
		Y	4.96	67.27	16.74		130.0	
		Z	4.98	67.36	16.83		130.0	
10597-AAA	IEEE 802.11n (HT Mixed, 20MHz, MCS6, 90pc duty cycle)	X	4.97	67.44	16.92	0.46	130.0	± 9.6 %
		Y	4.91	67.18	16.63		130.0	
		Z	4.93	67.28	16.72		130.0	
10598-AAA	IEEE 802.11n (HT Mixed, 20MHz, MCS7, 90pc duty cycle)	X	4.94	67.63	17.14	0.46	130.0	± 9.6 %
		Y	4.89	67.40	16.88		130.0	
		Z	4.91	67.48	16.96		130.0	
10599-AAA	IEEE 802.11n (HT Mixed, 40MHz, MCS0, 90pc duty cycle)	X	5.64	67.68	17.14	0.46	130.0	± 9.6 %
		Y	5.59	67.47	16.88		130.0	
		Z	5.61	67.54	16.96		130.0	
10600-AAA	IEEE 802.11n (HT Mixed, 40MHz, MCS1, 90pc duty cycle)	X	5.87	68.41	17.49	0.46	130.0	± 9.6 %
		Y	5.79	68.09	17.17		130.0	
		Z	5.81	68.18	17.26		130.0	
10601-AAA	IEEE 802.11n (HT Mixed, 40MHz, MCS2, 90pc duty cycle)	X	5.71	67.98	17.28	0.46	130.0	± 9.6 %
		Y	5.65	67.72	17.00		130.0	
		Z	5.66	67.81	17.08		130.0	
10602-AAA	IEEE 802.11n (HT Mixed, 40MHz, MCS3, 90pc duty cycle)	X	5.79	67.98	17.21	0.46	130.0	± 9.6 %
		Y	5.73	67.73	16.93		130.0	
		Z	5.75	67.82	17.01		130.0	
10603-AAA	IEEE 802.11n (HT Mixed, 40MHz, MCS4, 90pc duty cycle)	X	5.87	68.25	17.46	0.46	130.0	± 9.6 %
		Y	5.81	68.01	17.19		130.0	
		Z	5.83	68.09	17.27		130.0	
10604-AAA	IEEE 802.11n (HT Mixed, 40MHz, MCS5, 90pc duty cycle)	X	5.65	67.64	17.14	0.46	130.0	± 9.6 %
		Y	5.60	67.42	16.89		130.0	
		Z	5.61	67.50	16.96		130.0	
10605-AAA	IEEE 802.11n (HT Mixed, 40MHz, MCS6, 90pc duty cycle)	X	5.80	68.11	17.39	0.46	130.0	± 9.6 %
		Y	5.73	67.85	17.10		130.0	
		Z	5.75	67.93	17.19		130.0	
10606-AAA	IEEE 802.11n (HT Mixed, 40MHz, MCS7, 90pc duty cycle)	X	5.53	67.43	16.92	0.46	130.0	± 9.6 %
		Y	5.48	67.20	16.64		130.0	
		Z	5.50	67.29	16.73		130.0	

10607-AAA	IEEE 802.11ac WiFi (20MHz, MCS0, 90pc duty cycle)	X	4.80	66.40	16.54	0.46	130.0	± 9.6 %
		Y	4.75	66.17	16.27		130.0	
		Z	4.76	66.26	16.35		130.0	
10608-AAA	IEEE 802.11ac WiFi (20MHz, MCS1, 90pc duty cycle)	X	5.00	66.83	16.71	0.46	130.0	± 9.6 %
		Y	4.94	66.59	16.44		130.0	
		Z	4.96	66.68	16.52		130.0	
10609-AAA	IEEE 802.11ac WiFi (20MHz, MCS2, 90pc duty cycle)	X	4.89	66.71	16.57	0.46	130.0	± 9.6 %
		Y	4.83	66.45	16.28		130.0	
		Z	4.85	66.55	16.38		130.0	
10610-AAA	IEEE 802.11ac WiFi (20MHz, MCS3, 90pc duty cycle)	X	4.94	66.85	16.71	0.46	130.0	± 9.6 %
		Y	4.88	66.60	16.44		130.0	
		Z	4.90	66.69	16.53		130.0	
10611-AAA	IEEE 802.11ac WiFi (20MHz, MCS4, 90pc duty cycle)	X	4.86	66.68	16.58	0.46	130.0	± 9.6 %
		Y	4.80	66.42	16.30		130.0	
		Z	4.82	66.52	16.39		130.0	
10612-AAA	IEEE 802.11ac WiFi (20MHz, MCS5, 90pc duty cycle)	X	4.88	66.87	16.65	0.46	130.0	± 9.6 %
		Y	4.82	66.59	16.35		130.0	
		Z	4.84	66.69	16.44		130.0	
10613-AAA	IEEE 802.11ac WiFi (20MHz, MCS6, 90pc duty cycle)	X	4.89	66.78	16.55	0.46	130.0	± 9.6 %
		Y	4.82	66.49	16.24		130.0	
		Z	4.85	66.60	16.34		130.0	
10614-AAA	IEEE 802.11ac WiFi (20MHz, MCS7, 90pc duty cycle)	X	4.81	66.89	16.73	0.46	130.0	± 9.6 %
		Y	4.75	66.64	16.45		130.0	
		Z	4.77	66.73	16.54		130.0	
10615-AAA	IEEE 802.11ac WiFi (20MHz, MCS8, 90pc duty cycle)	X	4.87	66.56	16.40	0.46	130.0	± 9.6 %
		Y	4.81	66.27	16.09		130.0	
		Z	4.83	66.38	16.19		130.0	
10616-AAA	IEEE 802.11ac WiFi (40MHz, MCS0, 90pc duty cycle)	X	5.46	66.92	16.73	0.46	130.0	± 9.6 %
		Y	5.41	66.70	16.48		130.0	
		Z	5.43	66.79	16.56		130.0	
10617-AAA	IEEE 802.11ac WiFi (40MHz, MCS1, 90pc duty cycle)	X	5.54	67.11	16.80	0.46	130.0	± 9.6 %
		Y	5.48	66.88	16.54		130.0	
		Z	5.50	66.96	16.62		130.0	
10618-AAA	IEEE 802.11ac WiFi (40MHz, MCS2, 90pc duty cycle)	X	5.42	67.11	16.81	0.46	130.0	± 9.6 %
		Y	5.36	66.88	16.56		130.0	
		Z	5.38	66.97	16.63		130.0	
10619-AAA	IEEE 802.11ac WiFi (40MHz, MCS3, 90pc duty cycle)	X	5.45	66.98	16.69	0.46	130.0	± 9.6 %
		Y	5.39	66.74	16.43		130.0	
		Z	5.41	66.83	16.51		130.0	
10620-AAA	IEEE 802.11ac WiFi (40MHz, MCS4, 90pc duty cycle)	X	5.55	67.03	16.77	0.46	130.0	± 9.6 %
		Y	5.49	66.78	16.50		130.0	
		Z	5.51	66.88	16.58		130.0	
10621-AAA	IEEE 802.11ac WiFi (40MHz, MCS5, 90pc duty cycle)	X	5.51	67.03	16.86	0.46	130.0	± 9.6 %
		Y	5.46	66.84	16.63		130.0	
		Z	5.48	66.91	16.70		130.0	
10622-AAA	IEEE 802.11ac WiFi (40MHz, MCS6, 90pc duty cycle)	X	5.54	67.25	16.97	0.46	130.0	± 9.6 %
		Y	5.49	67.04	16.73		130.0	
		Z	5.50	67.11	16.80		130.0	



10623-AAA	IEEE 802.11ac WiFi (40MHz, MCS7, 90pc duty cycle)	X	5.41	66.79	16.63	0.46	130.0	± 9.6 %
		Y	5.36	66.56	16.37		130.0	
		Z	5.38	66.65	16.45		130.0	
10624-AAA	IEEE 802.11ac WiFi (40MHz, MCS8, 90pc duty cycle)	X	5.62	67.00	16.79	0.46	130.0	± 9.6 %
		Y	5.56	66.77	16.54		130.0	
		Z	5.58	66.86	16.62		130.0	
10625-AAA	IEEE 802.11ac WiFi (40MHz, MCS9, 90pc duty cycle)	X	6.10	68.33	17.51	0.46	130.0	± 9.6 %
		Y	6.00	67.98	17.19		130.0	
		Z	6.02	68.08	17.28		130.0	
10626-AAA	IEEE 802.11ac WiFi (80MHz, MCS0, 90pc duty cycle)	X	5.74	66.93	16.65	0.46	130.0	± 9.6 %
		Y	5.69	66.74	16.43		130.0	
		Z	5.71	66.82	16.50		130.0	
10627-AAA	IEEE 802.11ac WiFi (80MHz, MCS1, 90pc duty cycle)	X	6.03	67.63	16.96	0.46	130.0	± 9.6 %
		Y	5.97	67.40	16.71		130.0	
		Z	5.98	67.48	16.79		130.0	
10628-AAA	IEEE 802.11ac WiFi (80MHz, MCS2, 90pc duty cycle)	X	5.81	67.14	16.66	0.46	130.0	± 9.6 %
		Y	5.75	66.90	16.41		130.0	
		Z	5.77	67.00	16.49		130.0	
10629-AAA	IEEE 802.11ac WiFi (80MHz, MCS3, 90pc duty cycle)	X	5.89	67.21	16.69	0.46	130.0	± 9.6 %
		Y	5.84	67.00	16.45		130.0	
		Z	5.85	67.08	16.52		130.0	
10630-AAA	IEEE 802.11ac WiFi (80MHz, MCS4, 90pc duty cycle)	X	6.58	69.47	17.83	0.46	130.0	± 9.6 %
		Y	6.44	68.97	17.43		130.0	
		Z	6.47	69.10	17.53		130.0	
10631-AAA	IEEE 802.11ac WiFi (80MHz, MCS5, 90pc duty cycle)	X	6.29	68.65	17.58	0.46	130.0	± 9.6 %
		Y	6.21	68.38	17.32		130.0	
		Z	6.23	68.46	17.39		130.0	
10632-AAA	IEEE 802.11ac WiFi (80MHz, MCS6, 90pc duty cycle)	X	5.97	67.59	17.06	0.46	130.0	± 9.6 %
		Y	5.92	67.40	16.84		130.0	
		Z	5.93	67.46	16.90		130.0	
10633-AAA	IEEE 802.11ac WiFi (80MHz, MCS7, 90pc duty cycle)	X	5.86	67.25	16.74	0.46	130.0	± 9.6 %
		Y	5.80	67.03	16.49		130.0	
		Z	5.82	67.11	16.57		130.0	
10634-AAA	IEEE 802.11ac WiFi (80MHz, MCS8, 90pc duty cycle)	X	5.83	67.23	16.78	0.46	130.0	± 9.6 %
		Y	5.78	67.04	16.55		130.0	
		Z	5.80	67.11	16.62		130.0	
10635-AAA	IEEE 802.11ac WiFi (80MHz, MCS9, 90pc duty cycle)	X	5.74	66.71	16.29	0.46	130.0	± 9.6 %
		Y	5.68	66.44	16.01		130.0	
		Z	5.70	66.56	16.11		130.0	
10636-AAA	IEEE 1602.11ac WiFi (160MHz, MCS0, 90pc duty cycle)	X	6.17	67.34	16.76	0.46	130.0	± 9.6 %
		Y	6.11	67.15	16.53		130.0	
		Z	6.13	67.22	16.60		130.0	
10637-AAA	IEEE 1602.11ac WiFi (160MHz, MCS1, 90pc duty cycle)	X	6.35	67.79	16.97	0.46	130.0	± 9.6 %
		Y	6.29	67.57	16.73		130.0	
		Z	6.30	67.65	16.80		130.0	
10638-AAA	IEEE 1602.11ac WiFi (160MHz, MCS2, 90pc duty cycle)	X	6.35	67.77	16.94	0.46	130.0	± 9.6 %
		Y	6.29	67.54	16.69		130.0	
		Z	6.30	67.62	16.76		130.0	

10639-AAA	IIEEE 1602.11ac WiFi (160MHz, MCS3, 90pc duty cycle)	X	6.32	67.69	16.93	0.46	130.0	± 9.6 %
		Y	6.26	67.48	16.70		130.0	
		Z	6.28	67.56	16.77		130.0	
10640-AAA	IIEEE 1602.11ac WiFi (160MHz, MCS4, 90pc duty cycle)	X	6.35	67.80	16.94	0.46	130.0	± 9.6 %
		Y	6.28	67.54	16.68		130.0	
		Z	6.30	67.64	16.76		130.0	
10641-AAA	IIEEE 1602.11ac WiFi (160MHz, MCS5, 90pc duty cycle)	X	6.36	67.58	16.85	0.46	130.0	± 9.6 %
		Y	6.30	67.37	16.61		130.0	
		Z	6.32	67.45	16.69		130.0	
10642-AAA	IIEEE 1602.11ac WiFi (160MHz, MCS6, 90pc duty cycle)	X	6.40	67.80	17.11	0.46	130.0	± 9.6 %
		Y	6.34	67.61	16.89		130.0	
		Z	6.36	67.68	16.96		130.0	
10643-AAA	IIEEE 1602.11ac WiFi (160MHz, MCS7, 90pc duty cycle)	X	6.25	67.58	16.92	0.46	130.0	± 9.6 %
		Y	6.19	67.34	16.66		130.0	
		Z	6.21	67.43	16.74		130.0	
10644-AAA	IIEEE 1602.11ac WiFi (160MHz, MCS8, 90pc duty cycle)	X	6.47	68.26	17.28	0.46	130.0	± 9.6 %
		Y	6.39	67.96	16.99		130.0	
		Z	6.42	68.06	17.08		130.0	
10645-AAA	IIEEE 1602.11ac WiFi (160MHz, MCS9, 90pc duty cycle)	X	7.06	69.52	17.87	0.46	130.0	± 9.6 %
		Y	6.93	69.10	17.52		130.0	
		Z	6.96	69.22	17.62		130.0	
10646-AAC	LTE-TDD (SC-FDMA, 1 RB, 5 MHz, QPSK, UL Subframe=2,7)	X	100.00	148.85	48.77	9.30	60.0	± 9.6 %
		Y	80.54	141.06	46.17		60.0	
		Z	100.00	148.08	48.38		60.0	
10647-AAB	LTE-TDD (SC-FDMA, 1 RB, 20 MHz, QPSK, UL Subframe=2,7)	X	100.00	150.12	49.32	9.30	60.0	± 9.6 %
		Y	73.97	140.10	46.12		60.0	
		Z	100.00	149.31	48.92		60.0	
10648-AAA	CDMA2000 (1x Advanced)	X	0.92	66.97	13.32	0.00	150.0	± 9.6 %
		Y	0.75	63.96	11.29		150.0	
		Z	0.80	64.80	11.93		150.0	

<sup>E</sup> Uncertainty is determined using the max. deviation from linear response applying rectangular distribution and is expressed for the square of the field value.