



SAR EVALUATION REPORT

Applicant Name:
 LG Electronics MobileComm U.S.A., Inc.
 1000 Sylvan Avenue
 Englewood Cliffs, NJ 07632
 United States

Date of Testing:
 01/20/17 - 01/30/17
Test Site/Location:
 PCTEST Lab, Columbia, MD, USA
Document Serial No.:
 1M1701180032-01-R4.ZNF

FCC ID: ZNFH871

APPLICANT: LG ELECTRONICS MOBILECOMM U.S.A., INC.

DUT Type: Portable Handset
Application Type: Certification
FCC Rule Part(s): CFR §2.1093
Model: LG-H871
Additional Model(s): LGH871, H871, LG-H872, LGH872, H872, LG-H873, LGH873, H873, LG-H872PR, LGH872PR, H872PR

Equipment Class	Band & Mode	Tx Frequency	SAR		
			1 gm Head (W/kg)	1 gm Body-Worn (W/kg)	1 gm Hotspot (W/kg)
PCE	GSM/GPRS/EDGE 850	824.20 - 848.80 MHz	0.38	0.99	1.06
PCE	UMTS 850	826.40 - 846.60 MHz	< 0.1	0.26	0.26
PCE	UMTS 1750	1712.4 - 1752.6 MHz	0.16	0.96	0.96
PCE	GSM/GPRS/EDGE 1900	1850.20 - 1909.80 MHz	0.15	0.32	0.41
PCE	UMTS 1900	1852.4 - 1907.6 MHz	0.23	0.79	0.79
PCE	LTE Band 12	699.7 - 715.3 MHz	0.19	0.69	0.74
PCE	LTE Band 17	706.5 - 713.5 MHz	N/A	N/A	N/A
PCE	LTE Band 13	779.5 - 784.5 MHz	0.12	0.47	0.47
PCE	LTE Band 5 (Cell)	824.7 - 848.3 MHz	0.24	0.50	0.50
PCE	LTE Band 66 (AWS)	1710.7 - 1779.3 MHz	0.23	1.11	1.11
PCE	LTE Band 4 (AWS)	1710.7 - 1754.3 MHz	N/A	N/A	N/A
PCE	LTE Band 25 (PCS)	1850.7 - 1914.3 MHz	0.21	0.98	1.19
PCE	LTE Band 2 (PCS)	1850.7 - 1909.3 MHz	N/A	N/A	N/A
PCE	LTE Band 30	2307.5 - 2312.5 MHz	< 0.1	1.17	1.17
PCE	LTE Band 7	2502.5 - 2567.5 MHz	< 0.1	0.32	0.45
DTS	2.4 GHz WLAN	2412 - 2462 MHz	0.70	0.42	0.42
NIJ	U-NII-1	5180 - 5240 MHz	N/A	N/A	0.39
NIJ	U-NII-2A	5260 - 5320 MHz	0.65	0.40	N/A
NIJ	U-NII-2C	5500 - 5720 MHz	0.31	0.48	N/A
NIJ	U-NII-3	5745 - 5825 MHz	0.12	0.50	0.50
DSS/DTS	Bluetooth	2402 - 2480 MHz	N/A	0.11	N/A
Simultaneous SAR per KDB 690783 D01v01r03:			1.59	1.58	1.59

Note: This revised Test Report (S/N: 1M1701180032-01-R4.ZNF) supersedes and replaces the previously issued test report on the same subject device for the same type of testing as indicated. Please discard or destroy the previously issued test report(s) and dispose of it accordingly.

This wireless portable device has been shown to be capable of compliance for localized specific absorption rate (SAR) for uncontrolled environment/general population exposure limits specified in ANSI/IEEE C95.1-1992 and has been tested in accordance with the measurement procedures specified in Section 1.8 of this report; for North American frequency bands only.

I attest to the accuracy of data. All measurements reported herein were performed by me or were made under my supervision and are correct to the best of my knowledge and belief. I assume full responsibility for the completeness of these measurements and vouch for the qualifications of all persons taking them. Test results reported herein relate only to the item(s) tested.

Randy Ortanez
 President





The SAR Tick is an initiative of the Mobile Manufacturers Forum (MMF). While a product may be considered eligible, use of the SAR Tick logo requires an agreement with the MMF. Further details can be obtained by emailing: sartick@mmfai.info.

FCC ID: ZNFH871		SAR EVALUATION REPORT		Approved by: Quality Manager
Document S/N: 1M1701180032-01-R4.ZNF	Test Dates: 01/20/17 - 01/30/17	DUT Type: Portable Handset	Page 1 of 97	

TABLE OF CONTENTS

1	DEVICE UNDER TEST	3
2	LTE INFORMATION	13
3	INTRODUCTION	14
4	DOSIMETRIC ASSESSMENT	15
5	DEFINITION OF REFERENCE POINTS	16
6	TEST CONFIGURATION POSITIONS	17
7	RF EXPOSURE LIMITS	20
8	FCC MEASUREMENT PROCEDURES.....	21
9	RF CONDUCTED POWERS	27
10	SYSTEM VERIFICATION.....	51
11	SAR DATA SUMMARY	53
12	FCC MULTI-TX AND ANTENNA SAR CONSIDERATIONS.....	69
13	SAR MEASUREMENT VARIABILITY	92
14	EQUIPMENT LIST.....	93
15	MEASUREMENT UNCERTAINTIES.....	94
16	CONCLUSION.....	95
17	REFERENCES	96
APPENDIX A:	SAR TEST PLOTS	
APPENDIX B:	SAR DIPOLE VERIFICATION PLOTS	
APPENDIX C:	PROBE AND DIPOLE CALIBRATION CERTIFICATES	
APPENDIX D:	SAR TISSUE SPECIFICATIONS	
APPENDIX E:	SAR SYSTEM VALIDATION	
APPENDIX F:	DUT ANTENNA DIAGRAM & SAR TEST SETUP PHOTOGRAPHS	
APPENDIX G:	WIFI POWER REDUCTION VERIFICATION	

FCC ID: ZNFH871		SAR EVALUATION REPORT		Approved by: Quality Manager
Document S/N: 1M1701180032-01-R4.ZNF	Test Dates: 01/20/17 - 01/30/17	DUT Type: Portable Handset	Page 2 of 97	



1 DEVICE UNDER TEST

1.1 Device Overview

Band & Mode	Operating Modes	Tx Frequency
GSM/GPRS/EDGE 850	Voice/Data	824.20 - 848.80 MHz
UMTS 850	Voice/Data	826.40 - 846.60 MHz
UMTS 1750	Voice/Data	1712.4 - 1752.6 MHz
GSM/GPRS/EDGE 1900	Voice/Data	1850.20 - 1909.80 MHz
UMTS 1900	Voice/Data	1852.4 - 1907.6 MHz
LTE Band 12	Voice/Data	699.7 - 715.3 MHz
LTE Band 17	Voice/Data	706.5 - 713.5 MHz
LTE Band 13	Voice/Data	779.5 - 784.5 MHz
LTE Band 5 (Cell)	Voice/Data	824.7 - 848.3 MHz
LTE Band 66 (AWS)	Voice/Data	1710.7 - 1779.3 MHz
LTE Band 4 (AWS)	Voice/Data	1710.7 - 1754.3 MHz
LTE Band 25 (PCS)	Voice/Data	1850.7 - 1914.3 MHz
LTE Band 2 (PCS)	Voice/Data	1850.7 - 1909.3 MHz
LTE Band 30	Voice/Data	2307.5 - 2312.5 MHz
LTE Band 7	Voice/Data	2502.5 - 2567.5 MHz
2.4 GHz WLAN	Voice/Data	2412 - 2462 MHz
U-NII-1	Voice/Data	5180 - 5240 MHz
U-NII-2A	Voice/Data	5260 - 5320 MHz
U-NII-2C	Voice/Data	5500 - 5720 MHz
U-NII-3	Voice/Data	5745 - 5825 MHz
Bluetooth	Data	2402 - 2480 MHz
NFC	Data	13.56 MHz

1.2 Power Reduction for SAR

This device uses a fixed level power reduction mechanism for WLAN operations during voice or VoIP held to ear scenarios. Per FCC Guidance, the held-to-ear exposure conditions were evaluated at reduced power according to the head SAR positions described in IEEE 1528-2013. Detailed descriptions of the power reduction mechanism are included in the operational description. Additional test procedure information and data verifying the WLAN power reduction mechanism is included in Appendix G.

FCC ID: ZNFH871	 PCTEST ENGINEERING LABORATORY, INC.	SAR EVALUATION REPORT	 LG	Approved by: Quality Manager
Document S/N: 1M1701180032-01-R4.ZNF	Test Dates: 01/20/17 - 01/30/17	DUT Type: Portable Handset	Page 3 of 97	

1.3 Nominal and Maximum Output Power Specifications



This device operates using the following maximum and nominal output power specifications. SAR values were scaled to the maximum allowed power to determine compliance per KDB Publication 447498 D01v06.

1.3.1 Maximum PCE Power

Mode / Band		Voice (dBm)	Burst Average GMSK (dBm)				Burst Average 8-PSK (dBm)			
		1 TX Slot	1 TX Slots	2 TX Slots	3 TX Slots	4 TX Slots	1 TX Slots	2 TX Slots	3 TX Slots	4 TX Slots
GSM/GPRS/EDGE 850	Maximum	33.2	33.2	32.2	30.2	28.7	27.2	27.2	26.7	26.7
	Nominal	32.7	32.7	31.7	29.7	28.2	26.7	26.7	26.2	26.2
GSM/GPRS/EDGE 1900	Maximum	30.7	30.7	29.2	27.2	25.7	26.2	26.2	25.7	25.7
	Nominal	30.2	30.2	28.7	26.7	25.2	25.7	25.7	25.2	25.2

Mode / Band		Modulated Average (dBm)			
		3GPP WCDMA	3GPP HSDPA	3GPP HSUPA	3GPP DC-HSDPA
UMTS Band 5 (850 MHz)	Maximum	24.7	24.7	24.7	24.7
	Nominal	24.2	24.2	24.2	24.2
UMTS Band 4 (1750 MHz)	Maximum	25.0	25.0	25.0	25.0
	Nominal	24.5	24.5	24.5	24.5
UMTS Band 2 (1900 MHz)	Maximum	25.0	25.0	25.0	25.0
	Nominal	24.5	24.5	24.5	24.5

Mode / Band		Modulated Average (dBm)
LTE Band 12	Maximum	25.5
	Nominal	25.0
LTE Band 17	Maximum	25.5
	Nominal	25.0
LTE Band 13	Maximum	25.5
	Nominal	25.0
LTE Band 5 (Cell)	Maximum	25.5
	Nominal	25.0
LTE Band 66 (AWS)	Maximum	25.5
	Nominal	25.0
LTE Band 4 (AWS)	Maximum	25.5
	Nominal	25.0
LTE Band 25 (PCS)	Maximum	25.0
	Nominal	24.5
LTE Band 2 (PCS)	Maximum	25.0
	Nominal	24.5
LTE Band 30	Maximum	25.5
	Nominal	25.0
LTE Band 7	Maximum	25.5
	Nominal	25.0



FCC ID: ZNFH871	 PCTEST ENGINEERING LABORATORY, INC.	SAR EVALUATION REPORT	 LG	Approved by: Quality Manager
Document S/N: 1M1701180032-01-R4.ZNF	Test Dates: 01/20/17 - 01/30/17	DUT Type: Portable Handset	Page 4 of 97	

1.3.2 Maximum WLAN/BT Power

Mode / Band		Modulated Average - Single Tx Chain (Primary) (dBm)		
		Ch. 1-2	Ch. 3-9	Ch. 10-11
IEEE 802.11b (2.4 GHz)	Maximum	19.0	20.0	19.0
	Nominal	18.0	19.0	18.0
IEEE 802.11g (2.4 GHz)	Maximum	15.5	16.5	15.5
	Nominal	14.5	15.5	14.5
IEEE 802.11n (2.4 GHz)	Maximum	15.5	16.5	15.5
	Nominal	14.5	15.5	14.5
IEEE 802.11ac (2.4 GHz)	Maximum	15.5	16.5	15.5
	Nominal	14.5	15.5	14.5

Mode / Band		Modulated Average - Single Tx Chain (Secondary) (dBm)		
		Ch. 1-2	Ch. 3-9	Ch. 10-11
IEEE 802.11b (2.4 GHz)	Maximum	19.0	19.5	19.0
	Nominal	18.0	18.5	18.0
IEEE 802.11g (2.4 GHz)	Maximum	15.5	16.0	15.5
	Nominal	14.5	15.0	14.5
IEEE 802.11n (2.4 GHz)	Maximum	15.5	16.0	15.5
	Nominal	14.5	15.0	14.5
IEEE 802.11ac (2.4 GHz)	Maximum	15.5	16.0	15.5
	Nominal	14.5	15.0	14.5

Mode / Band		Modulated Average - MIMO (dBm)		
		Ch. 1-2	Ch. 3-9	Ch. 10-11
IEEE 802.11g (2.4 GHz)	Maximum	18.5	19.3	18.5
	Nominal	17.5	18.3	17.5
IEEE 802.11n (2.4 GHz)	Maximum	18.5	19.3	18.5
	Nominal	17.5	18.3	17.5
IEEE 802.11ac (2.4 GHz)	Maximum	18.5	19.3	18.5
	Nominal	17.5	18.3	17.5



FCC ID: ZNFH871	 PCTEST ENGINEERING LABORATORY, INC.	SAR EVALUATION REPORT		Approved by: Quality Manager
Document S/N: 1M1701180032-01-R4.ZNF	Test Dates: 01/20/17 - 01/30/17	DUT Type: Portable Handset		Page 5 of 97

Mode / Band		Modulated Average - Single Tx Chain (Primary) (dBm)					
		20 MHz Bandwidth		40 MHz Bandwidth		80 MHz Bandwidth	
		Ch. 36, 64, 100, 165	Ch. 40-48, 52-60, 104- 144, 149-161	Ch. 38, 62, 102	Ch. 46, 54, 110, 134, 142, 151, 159	Ch. 42, 58, 106	Ch. 138, 155
IEEE 802.11a (5 GHz)	Maximum	12.5	16.5				
	Nominal	11.5	15.5				
IEEE 802.11n (5 GHz)	Maximum	12.5	16.5	9.5	13.5		
	Nominal	11.5	15.5	8.5	12.5		
IEEE 802.11ac (5 GHz)	Maximum	12.5	16.5	9.5	13.5	8.5	11.5
	Nominal	11.5	15.5	8.5	12.5	7.5	10.5

Mode / Band		Modulated Average - Single Tx Chain (Secondary) (dBm)					
		20 MHz Bandwidth		40 MHz Bandwidth		80 MHz Bandwidth	
		Ch. 36, 64, 100, 165	Ch. 40-48, 52-60, 104- 144, 149-161	Ch. 38, 62, 102	Ch. 46, 54, 110, 134, 142, 151, 159	Ch. 42, 58, 106	Ch. 138, 155
IEEE 802.11a (5 GHz)	Maximum	12.5	16.5				
	Nominal	11.5	15.5				
IEEE 802.11n (5 GHz)	Maximum	12.5	16.5	9.5	13.5		
	Nominal	11.5	15.5	8.5	12.5		
IEEE 802.11ac (5 GHz)	Maximum	12.5	16.5	9.5	13.5	8.5	11.5
	Nominal	11.5	15.5	8.5	12.5	7.5	10.5

Mode / Band		Modulated Average - MIMO (dBm)					
		20 MHz Bandwidth		40 MHz Bandwidth		80 MHz Bandwidth	
		Ch. 36, 64, 100, 165	Ch. 40-48, 52-60, 104- 144, 149-161	Ch. 38, 62, 102	Ch. 46, 54, 110, 134, 142, 151, 159	Ch. 42, 58, 106	Ch. 138, 155
IEEE 802.11a (5 GHz)	Maximum	15.5	19.5				
	Nominal	14.5	18.5				
IEEE 802.11n (5 GHz)	Maximum	15.5	19.5	12.5	16.5		
	Nominal	14.5	18.5	11.5	15.5		
IEEE 802.11ac (5 GHz)	Maximum	15.5	19.5	12.5	16.5	11.5	14.5
	Nominal	14.5	18.5	11.5	15.5	10.5	13.5

Mode / Band		Modulated Average (dBm)
Bluetooth (1 Mbps)	Maximum	12.5
	Nominal	11.5
Bluetooth (2 Mbps)	Maximum	12.0
	Nominal	11.0
Bluetooth (3 Mbps)	Maximum	12.0
	Nominal	11.0
Bluetooth LE	Maximum	8.0
	Nominal	7.0



FCC ID: ZNFH871	 PCTEST ENGINEERING LABORATORY, INC.	SAR EVALUATION REPORT		Approved by: Quality Manager
Document S/N: 1M1701180032-01-R4.ZNF	Test Dates: 01/20/17 - 01/30/17	DUT Type: Portable Handset		Page 6 of 97

1.3.3 Reduced WLAN Power

Mode / Band		Modulated Average - Single Tx Chain (Primary) (dBm)		
		Ch. 1-2	Ch. 3-9	Ch. 10-11
IEEE 802.11b (2.4 GHz)	Maximum	14.5	15.5	14.5
	Nominal	13.5	14.5	13.5
IEEE 802.11g (2.4 GHz)	Maximum	14.5	15.5	14.5
	Nominal	13.5	14.5	13.5
IEEE 802.11n (2.4 GHz)	Maximum	14.5	15.5	14.5
	Nominal	13.5	14.5	13.5
IEEE 802.11ac (2.4 GHz)	Maximum	14.5	15.5	14.5
	Nominal	13.5	14.5	13.5

Mode / Band		Modulated Average - Single Tx Chain (Secondary) (dBm)		
		Ch. 1-2	Ch. 3-9	Ch. 10-11
IEEE 802.11b (2.4 GHz)	Maximum	15.0	15.5	15.0
	Nominal	14.0	14.5	14.0
IEEE 802.11g (2.4 GHz)	Maximum	15.0	15.5	15.0
	Nominal	14.0	14.5	14.0
IEEE 802.11n (2.4 GHz)	Maximum	15.0	15.5	15.0
	Nominal	14.0	14.5	14.0
IEEE 802.11ac (2.4 GHz)	Maximum	15.0	15.5	15.0
	Nominal	14.0	14.5	14.0



Mode / Band		Modulated Average - MIMO (dBm)		
		Ch. 1-2	Ch. 3-9	Ch. 10-11
IEEE 802.11g (2.4 GHz)	Maximum	17.8	18.5	17.8
	Nominal	16.8	17.5	16.8
IEEE 802.11n (2.4 GHz)	Maximum	17.8	18.5	17.8
	Nominal	16.8	17.5	16.8
IEEE 802.11ac (2.4 GHz)	Maximum	17.8	18.5	17.8
	Nominal	16.8	17.5	16.8

FCC ID: ZNFH871	 PCTEST ENGINEERING LABORATORY, INC.	SAR EVALUATION REPORT	 LG	Approved by: Quality Manager
Document S/N: 1M1701180032-01-R4.ZNF	Test Dates: 01/20/17 - 01/30/17	DUT Type: Portable Handset		Page 7 of 97

Mode / Band		Modulated Average - Single Tx Chain (Primary) (dBm)					
		20 MHz Bandwidth		40 MHz Bandwidth		80 MHz Bandwidth	
		Ch. 36, 64, 100, 165	Ch. 40-48, 52-60, 104- 144, 149-161	Ch. 38, 62, 102	Ch. 46, 54, 110, 134, 142, 151, 159	Ch. 42, 58, 106	Ch. 138, 155
IEEE 802.11a (5 GHz)	Maximum	12.5	14.5				
	Nominal	11.5	13.5				
IEEE 802.11n (5 GHz)	Maximum	12.5	14.5	9.5	13.5		
	Nominal	11.5	13.5	8.5	12.5		
IEEE 802.11ac (5 GHz)	Maximum	12.5	14.5	9.5	13.5	8.5	11.5
	Nominal	11.5	13.5	8.5	12.5	7.5	10.5

Mode / Band		Modulated Average - Single Tx Chain (Secondary) (dBm)					
		20 MHz Bandwidth		40 MHz Bandwidth		80 MHz Bandwidth	
		Ch. 36, 64, 100, 165	Ch. 40-48, 52-60, 104- 144, 149-161	Ch. 38, 62, 102	Ch. 46, 54, 110, 134, 142, 151, 159	Ch. 42, 58, 106	Ch. 138, 155
IEEE 802.11a (5 GHz)	Maximum	12.5	14.5				
	Nominal	11.5	13.5				
IEEE 802.11n (5 GHz)	Maximum	12.5	14.5	9.5	13.5		
	Nominal	11.5	13.5	8.5	12.5		
IEEE 802.11ac (5 GHz)	Maximum	12.5	14.5	9.5	13.5	8.5	11.5
	Nominal	11.5	13.5	8.5	12.5	7.5	10.5

Mode / Band		Modulated Average - MIMO (dBm)					
		20 MHz Bandwidth		40 MHz Bandwidth		80 MHz Bandwidth	
		Ch. 36, 64, 100, 165	Ch. 40-48, 52-60, 104- 144, 149-161	Ch. 38, 62, 102	Ch. 46, 54, 110, 134, 142, 151, 159	Ch. 42, 58, 106	Ch. 138, 155
IEEE 802.11a (5 GHz)	Maximum	15.5	17.5				
	Nominal	14.5	16.5				
IEEE 802.11n (5 GHz)	Maximum	15.5	17.5	12.5	16.5		
	Nominal	14.5	16.5	11.5	15.5		
IEEE 802.11ac (5 GHz)	Maximum	15.5	17.5	12.5	16.5	11.5	14.5
	Nominal	14.5	16.5	11.5	15.5	10.5	13.5

FCC ID: ZNFH871	 PCTEST ENGINEERING LABORATORY, INC.	SAR EVALUATION REPORT		Approved by: Quality Manager
Document S/N: 1M1701180032-01-R4.ZNF	Test Dates: 01/20/17 - 01/30/17	DUT Type: Portable Handset		Page 8 of 97

1.4 DUT Antenna Locations

The overall dimensions of this device are > 9 x 5 cm. The overall diagonal dimension of the device is ≤160 mm and the diagonal display is ≤150 mm. A diagram showing the location of the device antennas can be found in Appendix F.



**Table 1-1
Device Edges/Sides for SAR Testing**

Mode	Back	Front	Top	Bottom	Right	Left
GPRS 850	Yes	Yes	No	Yes	Yes	Yes
UMTS 850	Yes	Yes	No	Yes	Yes	Yes
UMTS 1750	Yes	Yes	No	Yes	No	Yes
GPRS 1900	Yes	Yes	No	Yes	No	Yes
UMTS 1900	Yes	Yes	No	Yes	No	Yes
LTE Band 12	Yes	Yes	No	Yes	Yes	Yes
LTE Band 13	Yes	Yes	No	Yes	Yes	Yes
LTE Band 5 (Cell)	Yes	Yes	No	Yes	Yes	Yes
LTE Band 66 (AWS)	Yes	Yes	No	Yes	No	Yes
LTE Band 25 (PCS)	Yes	Yes	No	Yes	No	Yes
LTE Band 30	Yes	Yes	No	Yes	Yes	Yes
LTE Band 7	Yes	Yes	No	Yes	No	Yes
2.4 GHz WLAN Ant 1	Yes	Yes	Yes	No	No	Yes
2.4 GHz WLAN Ant 2	Yes	Yes	Yes	No	No	Yes
5 GHz WLAN Ant 1	Yes	Yes	Yes	No	No	Yes
5 GHz WLAN Ant 2	Yes	Yes	Yes	No	No	Yes

Note: Particular DUT edges were not required to be evaluated for wireless router SAR if the edges were greater than 2.5 cm from the transmitting antenna according to FCC KDB Publication 941225 D06v02r01 Section III. The distances between the transmit antennas and the edges of the device are included in the filing. When wireless router mode is enabled, U-NII-2A, U-NII-2C operations are disabled. Therefore, U-NII-2A, U-NII-2C operations are not considered in this section.

1.5 Near Field Communications (NFC) Antenna

This DUT has NFC operations. The NFC antenna is integrated into the device for this model. Therefore, all SAR tests were performed with the device which already incorporates the NFC antenna. A diagram showing the location of the NFC antenna can be found in Appendix F.

FCC ID: ZNFH871	 PCTEST ENGINEERING LABORATORY, INC.	SAR EVALUATION REPORT	 LG	Approved by: Quality Manager
Document S/N: 1M1701180032-01-R4.ZNF	Test Dates: 01/20/17 - 01/30/17	DUT Type: Portable Handset	Page 9 of 97	

1.6 Simultaneous Transmission Capabilities

According to FCC KDB Publication 447498 D01v06, transmitters are considered to be transmitting simultaneously when there is overlapping transmission, with the exception of transmissions during network hand-offs with maximum hand-off duration less than 30 seconds. Possible transmission paths for the DUT are shown in Figure 1-1 and are color-coded to indicate communication modes which share the same path. Modes which share the same transmission path cannot transmit simultaneously with one another.

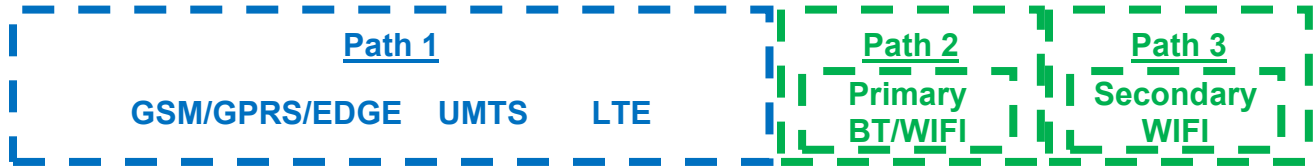



Figure 1-1
Simultaneous Transmission Paths

This device contains multiple transmitters that may operate simultaneously, and therefore requires a simultaneous transmission analysis according to FCC KDB Publication 447498 D01v06 4.3.2 procedures.

Table 1-2
Simultaneous Transmission Scenarios

No.	Capable Transmit Configuration	Head	Body-Worn Accessory	Wireless Router	Notes
1	GSM voice + 2.4 GHz WI-FI	Yes	Yes	N/A	
2	GSM voice + 5 GHz WI-FI	Yes	Yes	N/A	
3	GSM voice + 2.4 GHz Bluetooth	N/A	Yes	N/A	
4	GSM voice + 2.4 GHz WI-FI MIMO	Yes	Yes	N/A	
5	GSM voice + 5 GHz WI-FI MIMO	Yes	Yes	N/A	
6	GSM voice + 2.4 GHz WI-FI + 5 GHz WI-FI	Yes	Yes	N/A	
7	UMTS + 2.4 GHz WI-FI	Yes	Yes	Yes	
8	UMTS + 5 GHz WI-FI	Yes	Yes	Yes	
9	UMTS + 2.4 GHz Bluetooth	N/A	Yes	N/A	
10	UMTS + 2.4 GHz WI-FI MIMO	Yes	Yes	Yes	
11	UMTS + 5 GHz WI-FI MIMO	Yes	Yes	Yes	
12	UMTS + 2.4 GHz WI-FI + 5 GHz WI-FI	Yes	Yes	Yes	
13	LTE + 2.4 GHz WI-FI	Yes	Yes	Yes	
14	LTE + 5 GHz WI-FI	Yes	Yes	Yes	
15	LTE + 2.4 GHz Bluetooth	N/A	Yes	N/A	
16	LTE + 2.4 GHz WI-FI MIMO	Yes	Yes	Yes	
17	LTE + 5 GHz WI-FI MIMO	Yes	Yes	Yes	
18	LTE + 2.4 GHz WI-FI + 5 GHz WI-FI	Yes	Yes	Yes	
19	GPRS/EDGE + 2.4 GHz WI-FI	Yes*	Yes*	Yes	*-Pre-installed VOIP applications are considered.
20	GPRS/EDGE + 5 GHz WI-FI	Yes*	Yes*	Yes	*-Pre-installed VOIP applications are considered.
21	GPRS/EDGE + 2.4 GHz Bluetooth	N/A	Yes*	N/A	*-Pre-installed VOIP applications are considered.
22	GPRS/EDGE + 2.4 GHz WI-FI MIMO	Yes*	Yes*	Yes	*-Pre-installed VOIP applications are considered.
23	GPRS/EDGE + 5 GHz WI-FI MIMO	Yes*	Yes*	Yes	*-Pre-installed VOIP applications are considered.
24	GPRS/EDGE + 2.4 GHz WI-FI + 5 GHz WI-FI	Yes*	Yes*	Yes	*-Pre-installed VOIP applications are considered.

1. All unlicensed modes cannot transmit from the same antenna simultaneously.
2. All licensed modes share the same antenna path and cannot transmit simultaneously.
3. When the user utilizes multiple services in UMTS 3G mode it uses multi-Radio Access Bearer or multi-RAB. The power control is based on a physical control channel (Dedicated Physical Control Channel [DPCCH]) and power control will be adjusted to meet the needs of both services. Therefore, the UMTS+WLAN scenario also represents the UMTS Voice/DATA + WLAN Hotspot scenario.

FCC ID: ZNFH871	 PCTEST ENGINEERING LABORATORY, INC.	SAR EVALUATION REPORT	 LG	Approved by: Quality Manager
Document S/N: 1M1701180032-01-R4.ZNF	Test Dates: 01/20/17 - 01/30/17	DUT Type: Portable Handset		Page 10 of 97 REV 18.2 M 11/28/2016

4. Per the manufacturer, WIFI Direct is expected to be used in conjunction with a held-to-ear or body-worn accessory voice call. Simultaneous transmission scenarios involving WIFI direct are included in the above table.
5. 5 GHz Wireless Router is only supported for the U-NII-1 and U-NII-3 by S/W, therefore U-NII2A and U-NII2C were not evaluated for wireless router conditions.
6. This device supports 2x2 MIMO Tx for WLAN 802.11n/ac. Each WLAN antenna can transmit independently or together when operating with MIMO.
7. This device supports VOLTE and VoWIFI.

1.7 Miscellaneous SAR Test Considerations

(A) WIFI/BT

Since U-NII-1 and U-NII-2A bands have the same maximum output power and the highest reported SAR for U-NII-2A is less than 1.2 W/kg, SAR is not required for U-NII-1 band according to FCC KDB Publication 248227 D01v02r02.

Since Wireless Router operations are not allowed by the chipset firmware using U-NII-2A & U-NII-2C WIFI, only 2.4 GHz, U-NII-1 and U-NII-3 WIFI Hotspot SAR tests and combinations are considered for SAR with respect to Wireless Router configurations according to FCC KDB 941225 D06v02r01.

This device supports IEEE 802.11ac with the following features:

- a) Up to 80 MHz Bandwidth only
- b) No aggregate channel configurations
- c) 2 Tx antenna output
- d) 256 QAM is supported
- e) Band gap channels are supported

(B) Licensed Transmitter(s)



GSM/GPRS/EDGE DTM is not supported for US bands. Therefore, the GSM Voice modes in this report do not transmit simultaneously with GPRS/EDGE Data.

This device is only capable of QPSK HSUPA in the uplink. Therefore, no additional SAR tests are required beyond that described for devices with HSUPA in KDB 941225 D01v03r01.

LTE SAR for the higher modulations and lower bandwidths were not tested since the maximum average output power of all required channels and configurations was not more than 0.5 dB higher than the highest bandwidth; and the reported LTE SAR for the highest bandwidth was less than 1.45 W/kg for all configurations according to FCC KDB 941225 D05v02r04.

This device supports LTE Carrier Aggregation (CA) in the downlink only. All uplink communications are identical to Release 8 specifications. Per FCC KDB Publication 941225 D05A v01r02, SAR for LTE CA operations was not needed since the maximum average output power in LTE CA mode was not >0.25 dB higher than the maximum output power when downlink carrier aggregation was inactive.

This device supports 64QAM on the uplink for LTE Operations. Conducted powers for 64QAM uplink configurations were measured per Section 5.1 of FCC KDB Publication 941225 D05v02r05. SAR was not required for 64QAM since the highest maximum output power for 64 QAM is $\leq \frac{1}{2}$ dB higher than the same configuration in QPSK and the reported SAR for the QPSK configuration is ≤ 1.45 W/kg, per Section 5.2.4 of FCC KDB Publication 941225 D05v02r05.

FCC ID: ZNFH871	 PCTEST PROFESSIONAL LABORATORY, INC.	SAR EVALUATION REPORT	 LG	Approved by: Quality Manager
Document S/N: 1M1701180032-01-R4.ZNF	Test Dates: 01/20/17 - 01/30/17	DUT Type: Portable Handset	Page 11 of 97	

This device supports both LTE Band 12 and LTE Band 17. Since the supported frequency span for LTE Band 17 falls completely within the supported frequency span for LTE Band 12, LTE Band 17 target power is less than or equal to LTE Band 12 target power, and both LTE bands share the same transmission path, SAR was only assessed for LTE Band 12.

This device supports both LTE Band 66 and LTE Band 4. Since the supported frequency span for LTE Band 4 falls completely within the supported frequency span for LTE Band 66, LTE Band 4 target power is less than or equal to LTE Band 66 target power, and both LTE bands share the same transmission path, SAR was only assessed for LTE Band 66.

This device supports both LTE Band 25 and LTE Band 2. Since the supported frequency span for LTE Band 2 falls completely within the supported frequency span for LTE Band 25, LTE Band 2 target power is less than or equal to LTE Band 25 target power, and both LTE bands share the same transmission path, SAR was only assessed for LTE Band 25.



1.8 Guidance Applied

- IEEE 1528-2013
- FCC KDB Publication 941225 D01v03r01, D05v02r04, D05Av01r02, D06v02r01 (2G/3G/4G and Hotspot)
- FCC KDB Publication 248227 D01v02r02 (SAR Considerations for 802.11 Devices)
- FCC KDB Publication 447498 D01v06 (General SAR Guidance)
- FCC KDB Publication 865664 D01v01r04, D02v01r02 (SAR Measurements up to 6 GHz)
- October 2013 TCB Workshop Notes (GPRS Testing Considerations)



1.9 Device Serial Numbers

Several samples with identical hardware were used to support SAR testing. The manufacturer has confirmed that the device(s) tested have the same physical, mechanical and thermal characteristics and are within operational tolerances expected for production units.

	Head Serial Number	Body-Worn Serial Number	Hotspot Serial Number
GSM/GPRS/EDGE 850	08465	08465	08465
UMTS 850	08465	08465	08465
UMTS 1750	06440	08473	08473
GSM/GPRS/EDGE 1900	08473	08465	08465
UMTS 1900	08465	08465	08465
LTE Band 12	08523	08440	08440
LTE Band 13	08523	08440	08440
LTE Band 5 (Cell)	08516	08440	08440
LTE Band 66 (AWS)	08440	08440	08440
LTE Band 25 (PCS)	08457	08457	08457
LTE Band 30	08515	08457	08457
LTE Band 7	08523	08515	08515
2.4 GHz WLAN	08564	08564	08564
5 GHz WLAN	08564	08564	08564
Bluetooth	-	08564	-

FCC ID: ZNFH871	 SAR EVALUATION REPORT 		Approved by: Quality Manager
Document S/N: 1M1701180032-01-R4.ZNF	Test Dates: 01/20/17 - 01/30/17	DUT Type: Portable Handset	Page 12 of 97

LTE Information						
FCC ID	ZNFH871					
Form Factor	Portable Handset					
Frequency Range of each LTE transmission band	LTE Band 12 (699.7 - 715.3 MHz)					
	LTE Band 17 (706.5 - 713.5 MHz)					
	LTE Band 13 (779.5 - 784.5 MHz)					
	LTE Band 5 (Cell) (824.7 - 848.3 MHz)					
	LTE Band 66 (AWS) (1710.7 - 1779.3 MHz)					
	LTE Band 4 (AWS) (1710.7 - 1754.3 MHz)					
	LTE Band 25 (PCS) (1850.7 - 1914.3 MHz)					
	LTE Band 2 (PCS) (1850.7 - 1909.3 MHz)					
	LTE Band 30 (2307.5 - 2312.5 MHz)					
	LTE Band 7 (2502.5 - 2567.5 MHz)					
	Channel Bandwidths	LTE Band 12: 1.4 MHz, 3 MHz, 5 MHz, 10 MHz				
		LTE Band 17: 5 MHz, 10 MHz				
		LTE Band 13: 5 MHz, 10 MHz				
LTE Band 5 (Cell): 1.4 MHz, 3 MHz, 5 MHz, 10 MHz						
LTE Band 66 (AWS): 1.4 MHz, 3 MHz, 5 MHz, 10 MHz, 15 MHz, 20 MHz						
LTE Band 4 (AWS): 1.4 MHz, 3 MHz, 5 MHz, 10 MHz, 15 MHz, 20 MHz						
LTE Band 25 (PCS): 1.4 MHz, 3 MHz, 5 MHz, 10 MHz, 15 MHz, 20 MHz						
LTE Band 2 (PCS): 1.4 MHz, 3 MHz, 5 MHz, 10 MHz, 15 MHz, 20 MHz						
LTE Band 30: 5 MHz, 10 MHz						
LTE Band 7: 5 MHz, 10 MHz, 15 MHz, 20 MHz						
Channel Numbers and Frequencies (MHz)		Low	Low-Mid	Mid	Mid-High	High
LTE Band 12: 1.4 MHz		699.7 (23017)	N/A	707.5 (23095)	N/A	715.3 (23173)
LTE Band 12: 3 MHz		700.5 (23025)	N/A	707.5 (23095)	N/A	714.5 (23165)
LTE Band 12: 5 MHz	701.5 (23035)	N/A	707.5 (23095)	N/A	713.5 (23155)	
LTE Band 12: 10 MHz	704 (23060)	N/A	707.5 (23095)	N/A	711 (23130)	
LTE Band 17: 5 MHz	706.5 (23755)	N/A	710 (23790)	N/A	713.5 (23825)	
LTE Band 17: 10 MHz	709 (23780)	N/A	710 (23790)	N/A	711 (23800)	
LTE Band 13: 5 MHz	779.5 (23205)	N/A	782 (23230)	N/A	784.5 (23255)	
LTE Band 13: 10 MHz	N/A	N/A	782 (23230)	N/A	N/A	
LTE Band 5 (Cell): 1.4 MHz	824.7 (20407)	N/A	836.5 (20525)	N/A	848.3 (20643)	
LTE Band 5 (Cell): 3 MHz	825.5 (20415)	N/A	836.5 (20525)	N/A	847.5 (20635)	
LTE Band 5 (Cell): 5 MHz	826.5 (20425)	N/A	836.5 (20525)	N/A	846.5 (20625)	
LTE Band 5 (Cell): 10 MHz	829 (20450)	N/A	836.5 (20525)	N/A	844 (20600)	
LTE Band 66 (AWS): 1.4 MHz	1710.7 (131979)	1733.6 (132208)	1745 (132322)	1756.4 (132436)	1779.3 (132665)	
LTE Band 66 (AWS): 3 MHz	1711.5 (131987)	N/A	1745 (132322)	N/A	1778.5 (132657)	
LTE Band 66 (AWS): 5 MHz	1712.5 (131997)	N/A	1745 (132322)	N/A	1777.5 (132647)	
LTE Band 66 (AWS): 10 MHz	1715 (132022)	N/A	1745 (132322)	N/A	1775 (132622)	
LTE Band 66 (AWS): 15 MHz	1717.5 (132047)	N/A	1745 (132322)	N/A	1772.5 (132597)	
LTE Band 66 (AWS): 20 MHz	1720 (132072)	N/A	1745 (132322)	N/A	1770 (132572)	
LTE Band 4 (AWS): 1.4 MHz	1710.7 (19957)	N/A	1732.5 (20175)	N/A	1754.3 (20393)	
LTE Band 4 (AWS): 3 MHz	1711.5 (19965)	N/A	1732.5 (20175)	N/A	1753.5 (20385)	
LTE Band 4 (AWS): 5 MHz	1712.5 (19975)	N/A	1732.5 (20175)	N/A	1752.5 (20375)	
LTE Band 4 (AWS): 10 MHz	1715 (20000)	N/A	1732.5 (20175)	N/A	1750 (20350)	
LTE Band 4 (AWS): 15 MHz	1717.5 (20025)	N/A	1732.5 (20175)	N/A	1747.5 (20325)	
LTE Band 4 (AWS): 20 MHz	1720 (20050)	N/A	1732.5 (20175)	N/A	1745 (20300)	
LTE Band 25 (PCS): 1.4 MHz	1850.7 (26047)	N/A	1882.5 (26365)	N/A	1914.3 (26683)	
LTE Band 25 (PCS): 3 MHz	1851.5 (26055)	N/A	1882.5 (26365)	N/A	1913.5 (26675)	
LTE Band 25 (PCS): 5 MHz	1852.5 (26065)	N/A	1882.5 (26365)	N/A	1912.5 (26665)	
LTE Band 25 (PCS): 10 MHz	1855 (26090)	N/A	1882.5 (26365)	N/A	1910 (26640)	
LTE Band 25 (PCS): 15 MHz	1857.5 (26115)	N/A	1882.5 (26365)	N/A	1907.5 (26615)	
LTE Band 25 (PCS): 20 MHz	1860 (26140)	N/A	1882.5 (26365)	N/A	1905 (26590)	
LTE Band 2 (PCS): 1.4 MHz	1850.7 (18607)	N/A	1880 (18900)	N/A	1909.3 (19193)	
LTE Band 2 (PCS): 3 MHz	1851.5 (18615)	N/A	1880 (18900)	N/A	1908.5 (19185)	
LTE Band 2 (PCS): 5 MHz	1852.5 (18625)	N/A	1880 (18900)	N/A	1907.5 (19175)	
LTE Band 2 (PCS): 10 MHz	1855 (18650)	N/A	1880 (18900)	N/A	1905 (19150)	
LTE Band 2 (PCS): 15 MHz	1857.5 (18675)	N/A	1880 (18900)	N/A	1902.5 (19125)	
LTE Band 2 (PCS): 20 MHz	1860 (18700)	N/A	1880 (18900)	N/A	1900 (19100)	
LTE Band 30: 5 MHz	2307.5 (27685)	N/A	2310 (27710)	N/A	2312.5 (27735)	
LTE Band 30: 10 MHz	N/A	N/A	2310 (27710)	N/A	N/A	
LTE Band 7: 5 MHz	2502.5 (20775)	N/A	2535 (21100)	N/A	2567.5 (21425)	
LTE Band 7: 10 MHz	2505 (20800)	N/A	2535 (21100)	N/A	2565 (21400)	
LTE Band 7: 15 MHz	2507.5 (20825)	N/A	2535 (21100)	N/A	2562.5 (21375)	
LTE Band 7: 20 MHz	2510 (20850)	N/A	2535 (21100)	N/A	2560 (21350)	
UE Category	11					
Modulations Supported in UL	QPSK, 16QAM, 64QAM					
LTE MPR Permanently implemented per 3GPP TS 36.101 section 6.2.3-6.2.5? (manufacturer attestation to be provided)	YES					
A-MPR (Additional MPR) disabled for SAR Testing?	YES					
LTE Carrier Aggregation Possible Combinations	The technical description includes all the possible carrier aggregation combinations					
LTE Release 11 Additional Information	This device does not support full CA features on 3GPP Release 11. It supports a maximum of 3 carriers in the downlink. All uplink communications are identical to the Release 8 Specifications. Uplink communications are done on the PCC. The following LTE Release 11 Features are not supported: Relay, HetNet, Enhanced MIMO, eICIC, WiFi Offloading, MDH, eMBMS, Cross-Carrier Scheduling, Enhanced SC-FDMA.					

FCC ID: ZNFH871		SAR EVALUATION REPORT		Approved by: Quality Manager
Document S/N: 1M1701180032-01-R4.ZNF	Test Dates: 01/20/17 - 01/30/17	DUT Type: Portable Handset		Page 13 of 97

3 INTRODUCTION

The FCC and Innovation, Science, and Economic Development Canada have adopted the guidelines for evaluating the environmental effects of radio frequency (RF) radiation in ET Docket 93-62 on Aug. 6, 1996 and Health Canada Safety Code 6 to protect the public and workers from the potential hazards of RF emissions due to FCC-regulated portable devices. [1]

The safety limits used for the environmental evaluation measurements are based on the criteria published by the American National Standards Institute (ANSI) for localized specific absorption rate (SAR) in IEEE/ANSI C95.1-1992 Standard for Safety Levels with Respect to Human Exposure to Radio Frequency Electromagnetic Fields, 3 kHz to 300 GHz [3] and Health Canada RF Exposure Guidelines Safety Code 6 [22]. The measurement procedure described in IEEE/ANSI C95.3-2002 Recommended Practice for the Measurement of Potentially Hazardous Electromagnetic Fields - RF and Microwave [4] is used for guidance in measuring the Specific Absorption Rate (SAR) due to the RF radiation exposure from the Equipment Under Test (EUT). These criteria for SAR evaluation are similar to those recommended by the International Committee for Non-Ionizing Radiation Protection (ICNIRP) in Biological Effects and Exposure Criteria for Radiofrequency Electromagnetic Fields,” Report No. Vol 74. SAR is a measure of the rate of energy absorption due to exposure to an RF transmitting source. SAR values have been related to threshold levels for potential biological hazards.

3.1 SAR Definition

Specific Absorption Rate is defined as the time derivative (rate) of the incremental energy (dU) absorbed by (dissipated in) an incremental mass (dm) contained in a volume element (dV) of a given density (ρ). It is also defined as the rate of RF energy absorption per unit mass at a point in an absorbing body (see Equation 3-1).

**Equation 3-1
SAR Mathematical Equation**

$$SAR = \frac{d}{dt} \left(\frac{dU}{dm} \right) = \frac{d}{dt} \left(\frac{dU}{\rho dv} \right)$$



SAR is expressed in units of Watts per Kilogram (W/kg).

$$SAR = \frac{\sigma \cdot E^2}{\rho}$$

where:

- σ = conductivity of the tissue-simulating material (S/m)
- ρ = mass density of the tissue-simulating material (kg/m³)
- E = Total RMS electric field strength (V/m)

NOTE: The primary factors that control rate of energy absorption were found to be the wavelength of the incident field in relation to the dimensions and geometry of the irradiated organism, the orientation of the organism in relation to the polarity of field vectors, the presence of reflecting surfaces, and whether conductive contact is made by the organism with a ground plane.[6]

FCC ID: ZNFH871	 PCTEST ENGINEERING LABORATORY, INC.	SAR EVALUATION REPORT	 LG	Approved by: Quality Manager
Document S/N: 1M1701180032-01-R4.ZNF	Test Dates: 01/20/17 - 01/30/17	DUT Type: Portable Handset	Page 14 of 97	

4 DOSIMETRIC ASSESSMENT

4.1 Measurement Procedure

The evaluation was performed using the following procedure compliant to FCC KDB Publication 865664 D01v01r04 and IEEE 1528-2013:

1. The SAR distribution at the exposed side of the head or body was measured at a distance no greater than 5.0 mm from the inner surface of the shell. The area covered the entire dimension of the device-head and body interface and the horizontal grid resolution was determined per FCC KDB Publication 865664 D01v01r04 (See Table 4-1) and IEEE 1528-2013.
2. The point SAR measurement was taken at the maximum SAR region determined from Step 1 to enable the monitoring of SAR fluctuations/drifts during the 1g/10g cube evaluation. SAR at this fixed point was measured and used as a reference value.
3. Based on the area scan data, the peak of the region with maximum SAR was determined by spline interpolation. Around this point, a volume was assessed according to the measurement resolution and volume size requirements of FCC KDB Publication 865664 D01v01r04 (See Table 4-1) and IEEE 1528-2013. On the basis of this data set, the spatial peak SAR value was evaluated with the following procedure (see references or the DASY manual online for more details):
 - a. SAR values at the inner surface of the phantom are extrapolated from the measured values along the line away from the surface with spacing no greater than that in Table 4-1. The extrapolation was based on a least-squares algorithm. A polynomial of the fourth order was calculated through the points in the z-axis (normal to the phantom shell).
 - b. After the maximum interpolated values were calculated between the points in the cube, the SAR was averaged over the spatial volume (1g or 10g) using a 3D-Spline interpolation algorithm. The 3D-spline is composed of three one-dimensional splines with the “Not a knot” condition (in x, y, and z directions). The volume was then integrated with the trapezoidal algorithm. One thousand points (10 x 10 x 10) were obtained through interpolation, in order to calculate the averaged SAR.
 - c. All neighboring volumes were evaluated until no neighboring volume with a higher average value was found.
4. The SAR reference value, at the same location as step 2, was re-measured after the zoom scan was complete to calculate the SAR drift. If the drift deviated by more than 5%, the SAR test and drift measurements were repeated.

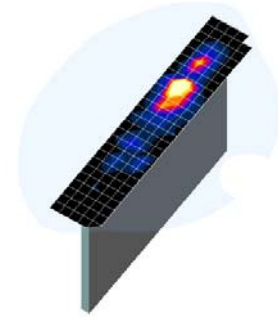



Figure 4-1
Sample SAR Area Scan

Table 4-1
Area and Zoom Scan Resolutions per FCC KDB Publication 865664 D01v01r04*

Frequency	Maximum Area Scan Resolution (mm) ($\Delta x_{area}, \Delta y_{area}$)	Maximum Zoom Scan Resolution (mm) ($\Delta x_{zoom}, \Delta y_{zoom}$)	Maximum Zoom Scan Spatial Resolution (mm)			Minimum Zoom Scan Volume (mm) (x,y,z)
			Uniform Grid	Graded Grid		
			$\Delta z_{zoom}(n)$	$\Delta z_{zoom}(1)^*$	$\Delta z_{zoom}(n>1)^*$	
≤ 2 GHz	≤ 15	≤ 8	≤ 5	≤ 4	≤ 1.5* $\Delta z_{zoom}(n-1)$	≥ 30
2-3 GHz	≤ 12	≤ 5	≤ 5	≤ 4	≤ 1.5* $\Delta z_{zoom}(n-1)$	≥ 30
3-4 GHz	≤ 12	≤ 5	≤ 4	≤ 3	≤ 1.5* $\Delta z_{zoom}(n-1)$	≥ 28
4-5 GHz	≤ 10	≤ 4	≤ 3	≤ 2.5	≤ 1.5* $\Delta z_{zoom}(n-1)$	≥ 25
5-6 GHz	≤ 10	≤ 4	≤ 2	≤ 2	≤ 1.5* $\Delta z_{zoom}(n-1)$	≥ 22

*Also compliant to IEEE 1528-2013 Table 6

FCC ID: ZNFH871	 SAR EVALUATION REPORT 		Approved by: Quality Manager
Document S/N: 1M1701180032-01-R4.ZNF	Test Dates: 01/20/17 - 01/30/17	DUT Type: Portable Handset	Page 15 of 97

5 DEFINITION OF REFERENCE POINTS

5.1 EAR REFERENCE POINT

Figure 5-2 shows the front, back and side views of the SAM Twin Phantom. The point “M” is the reference point for the center of the mouth, “LE” is the left ear reference point (ERP), and “RE” is the right ERP. The ERP is 15mm posterior to the entrance to the ear canal (EEC) along the B-M line (Back-Mouth), as shown in Figure 5-1. The plane passing through the two ear canals and M is defined as the Reference Plane. The line N-F (Neck-Front), also called the Reference Pivoting Line, is not perpendicular to the reference plane (see Figure 5-1). Line B-M is perpendicular to the N-F line. Both N-F and B-M lines are marked on the external phantom shell to facilitate handset positioning [5].

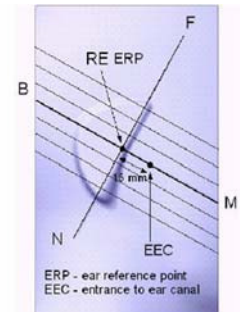

Figure 5-1
Close-Up Side view of ERP

5.2 HANDSET REFERENCE POINTS

Two imaginary lines on the handset were established: the vertical centerline and the horizontal line. The test device was placed in a normal operating position with the acoustic output located along the “vertical centerline” on the front of the device aligned to the “ear reference point” (See Figure 5-3). The acoustic output was then located at the same level as the center of the ear reference point. The test device was positioned so that the “vertical centerline” was bisecting the front surface of the handset at its top and bottom edges, positioning the “ear reference point” on the outer surface of the both the left and right head phantoms on the ear reference point.



Figure 5-2
Front, back and side view of SAM Twin Phantom

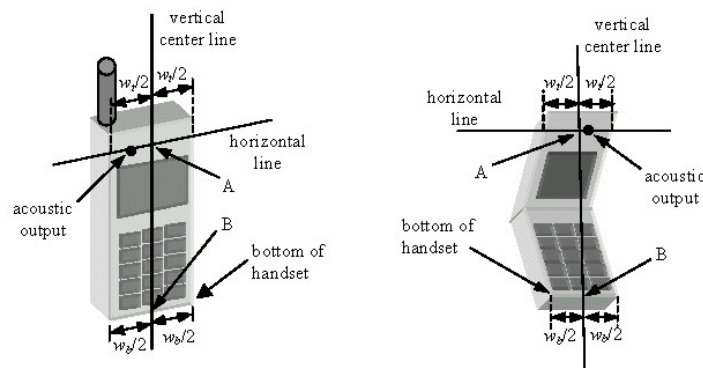



Figure 5-3
Handset Vertical Center & Horizontal Line Reference Points

FCC ID: ZNFH871	 PCTEST ENGINEERING LABORATORY, INC.	SAR EVALUATION REPORT	 LG	Approved by: Quality Manager
Document S/N: 1M1701180032-01-R4.ZNF	Test Dates: 01/20/17 - 01/30/17	DUT Type: Portable Handset		Page 16 of 97

6 TEST CONFIGURATION POSITIONS

6.1 Device Holder

The device holder is made out of low-loss POM material having the following dielectric parameters: relative permittivity $\epsilon = 3$ and loss tangent $\delta = 0.02$.

6.2 Positioning for Cheek

1. The test device was positioned with the device close to the surface of the phantom such that point A is on the (virtual) extension of the line passing through points RE and LE on the phantom (see Figure 6-1), such that the plane defined by the vertical center line and the horizontal line of the phone is approximately parallel to the sagittal plane of the phantom.





Figure 6-1 Front, Side and Top View of Cheek Position

2. The handset was translated towards the phantom along the line passing through RE & LE until the handset touches the pinna.
3. While maintaining the handset in this plane, the handset was rotated around the LE-RE line until the vertical centerline was in the reference plane.
4. The phone was then rotated around the vertical centerline until the phone (horizontal line) was symmetrical with respect to the line NF.
5. While maintaining the vertical centerline in the reference plane, keeping point A on the line passing through RE and LE, and maintaining the device contact with the ear, the device was rotated about the NF line until any point on the handset made contact with a phantom point below the ear (cheek) (See Figure 6-2).

6.3 Positioning for Ear / 15° Tilt

With the test device aligned in the “Cheek Position”:

1. While maintaining the orientation of the phone, the phone was retracted parallel to the reference plane far enough to enable a rotation of the phone by 15 degrees.
2. The phone was then rotated around the horizontal line by 15 degrees.
3. While maintaining the orientation of the phone, the phone was moved parallel to the reference plane until any part of the handset touched the head. (In this position, point A was located on the line RE-LE). The tilted position is obtained when the contact is on the pinna. If the contact was at any location other than the pinna, the angle of the phone would then be reduced. In this situation, the tilted position was obtained when any part of the phone was in contact of the ear as well as a second part of the phone was in contact with the head (see Figure 6-2).

FCC ID: ZNFH871	 PCTEST ENGINEERING LABORATORY, INC.	SAR EVALUATION REPORT	 LG	Approved by: Quality Manager
Document S/N: 1M1701180032-01-R4.ZNF	Test Dates: 01/20/17 - 01/30/17	DUT Type: Portable Handset		Page 17 of 97

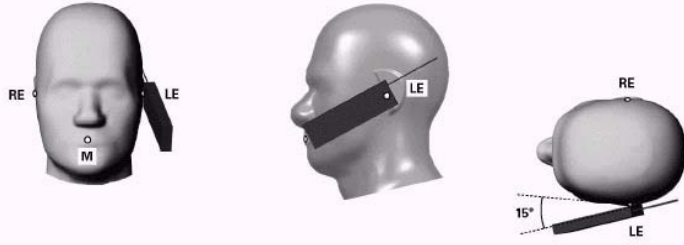

Figure 6-2 Front, Side and Top View of Ear/15° Tilt Position

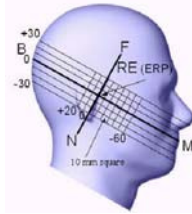

Figure 6-3 Side view w/ relevant markings

6.4 SAR Evaluations near the Mouth/Jaw Regions of the SAM Phantom

Antennas located near the bottom of a phone may require SAR measurements around the mouth and jaw regions of the SAM head phantom. This typically applies to clam-shell style phones that are generally longer in the unfolded normal use positions or to certain older style long rectangular phones. Per IEEE 1528-2013, a rotated SAM phantom is necessary to allow probe access to such regions. Both SAM heads of the TwinSAM-Chin20 are rotated 20 degrees around the NF line. Each head can be removed from the table for emptying and cleaning.

Under these circumstances, the following procedures apply, adopted from the FCC guidance on SAR handsets document FCC KDB Publication 648474 D04v01r03. The SAR required in these regions of SAM should be measured using a flat phantom. The phone should be positioned with a separation distance of 4 mm between the ear reference point (ERP) and the outer surface of the flat phantom shell. While maintaining this distance at the ERP location, the low (bottom) edge of the phone should be lowered from the phantom to establish the same separation distance between the peak SAR location identified by the truncated partial SAR distribution measured with the SAM phantom. The distance from the peak SAR location to the phone is determined by the straight line passing perpendicularly through the phantom surface. When it is not feasible to maintain 4 mm separation at the ERP while also establishing the required separation at the peak SAR location, the top edge of the phone will be allowed to touch the phantom with a separation < 4 mm at the ERP. The phone should not be tilted to the left or right while placed in this inclined position to the flat phantom.

6.5 Body-Worn Accessory Configurations

Body-worn operating configurations are tested with the belt-clips and holsters attached to the device and positioned against a flat phantom in a normal use configuration (see Figure 6-4). Per FCC KDB Publication 648474 D04v01r03, Body-worn accessory exposure is typically related to voice mode operations when handsets are carried in body-worn accessories. The body-worn accessory procedures in FCC KDB Publication 447498 D01v06 should be used to test for body-worn accessory SAR compliance, without a headset connected to it. This enables the test results for such configuration to be compatible with that required for hotspot mode when the body-worn accessory test separation distance is greater than or equal to that required for hotspot mode, when applicable. When the reported SAR for a body-worn accessory, measured without a headset connected to the handset, is > 1.2 W/kg, the highest reported SAR configuration for that wireless mode and frequency band should be repeated for that body-worn accessory with a headset attached to the handset.

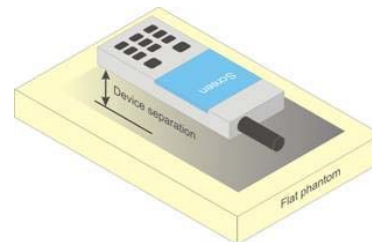



Figure 6-4 Sample Body-Worn Diagram

Accessories for Body-worn operation configurations are divided into two categories: those that do not contain metallic components and those that do contain metallic components. When multiple accessories that do not

FCC ID: ZNFH871	 PCTEST PROFESSIONAL LABORATORY, INC.	SAR EVALUATION REPORT	 LG	Approved by: Quality Manager
Document S/N: 1M1701180032-01-R4.ZNF	Test Dates: 01/20/17 - 01/30/17	DUT Type: Portable Handset		Page 18 of 97

contain metallic components are supplied with the device, the device is tested with only the accessory that dictates the closest spacing to the body. Then multiple accessories that contain metallic components are tested with the device with each accessory. If multiple accessories share an identical metallic component (i.e. the same metallic belt-clip used with different holsters with no other metallic components) only the accessory that dictates the closest spacing to the body is tested.

Body-worn accessories may not always be supplied or available as options for some devices intended to be authorized for body-worn use. In this case, a test configuration with a separation distance between the back of the device and the flat phantom is used. Test position spacing was documented.

Transmitters that are designed to operate in front of a person's face, as in push-to-talk configurations, are tested for SAR compliance with the front of the device positioned to face the flat phantom in head fluid. For devices that are carried next to the body such as a shoulder, waist or chest-worn transmitters, SAR compliance is tested with the accessories, including headsets and microphones, attached to the device and positioned against a flat phantom in a normal use configuration.

6.6 Extremity Exposure Configurations



Devices that are designed or intended for use on extremities or mainly operated in extremity only exposure conditions; i.e., hands, wrists, feet and ankles, may require extremity SAR evaluation. When the device also operates in close proximity to the user's body, SAR compliance for the body is also required. The 1-g body and 10-g extremity SAR Exclusion Thresholds found in KDB Publication 447498 D01v06 should be applied to determine SAR test requirements.

Per KDB Publication 447498 D01v06, Cell phones (handsets) are not normally designed to be used on extremities or operated in extremity only exposure conditions. The maximum output power levels of handsets generally do not require extremity SAR testing to show compliance. Therefore, extremity SAR was not evaluated for this device.

6.7 Wireless Router Configurations

Some battery-operated handsets have the capability to transmit and receive user data through simultaneous transmission of WIFI simultaneously with a separate licensed transmitter. The FCC has provided guidance in FCC KDB Publication 941225 D06v02r01 where SAR test considerations for handsets ($L \times W \geq 9 \text{ cm} \times 5 \text{ cm}$) are based on a composite test separation distance of 10 mm from the front, back and edges of the device containing transmitting antennas within 2.5 cm of their edges, determined from general mixed use conditions for this type of devices. Since the hotspot SAR results may overlap with the body-worn accessory SAR requirements, the more conservative configurations can be considered, thus excluding some body-worn accessory SAR tests.

When the user enables the personal wireless router functions for the handset, actual operations include simultaneous transmission of both the WIFI transmitter and another licensed transmitter. Both transmitters often do not transmit at the same transmitting frequency and thus cannot be evaluated for SAR under actual use conditions due to the limitations of the SAR assessment probes. Therefore, SAR must be evaluated for each frequency transmission and mode separately and spatially summed with the WIFI transmitter according to FCC KDB Publication 447498 D01v06 procedures. The "Portable Hotspot" feature on the handset was NOT activated during SAR assessments, to ensure the SAR measurements were evaluated for a single transmission frequency RF signal at a time.

FCC ID: ZNFH871		SAR EVALUATION REPORT		Approved by: Quality Manager
Document S/N: 1M1701180032-01-R4.ZNF	Test Dates: 01/20/17 - 01/30/17	DUT Type: Portable Handset		Page 19 of 97

7 RF EXPOSURE LIMITS

7.1 Uncontrolled Environment

UNCONTROLLED ENVIRONMENTS are defined as locations where there is the exposure of individuals who have no knowledge or control of their exposure. The general population/uncontrolled exposure limits are applicable to situations in which the general public may be exposed or in which persons who are exposed as a consequence of their employment may not be made fully aware of the potential for exposure or cannot exercise control over their exposure. Members of the general public would come under this category when exposure is not employment-related; for example, in the case of a wireless transmitter that exposes persons in its vicinity.



7.2 Controlled Environment

CONTROLLED ENVIRONMENTS are defined as locations where there is exposure that may be incurred by persons who are aware of the potential for exposure, (i.e. as a result of employment or occupation). In general, occupational/controlled exposure limits are applicable to situations in which persons are exposed as a consequence of their employment, who have been made fully aware of the potential for exposure and can exercise control over their exposure. This exposure category is also applicable when the exposure is of a transient nature due to incidental passage through a location where the exposure levels may be higher than the general population/uncontrolled limits, but the exposed person is fully aware of the potential for exposure and can exercise control over his or her exposure by leaving the area or by some other appropriate means.

**Table 7-1
SAR Human Exposure Specified in ANSI/IEEE C95.1-1992 and Health Canada Safety Code 6**

HUMAN EXPOSURE LIMITS		
	UNCONTROLLED ENVIRONMENT <i>General Population</i> (W/kg) or (mW/g)	CONTROLLED ENVIRONMENT <i>Occupational</i> (W/kg) or (mW/g)
Peak Spatial Average SAR Head	1.6	8.0
Whole Body SAR	0.08	0.4
Peak Spatial Average SAR Hands, Feet, Ankle, Wrists, etc.	4.0	20

1. The Spatial Peak value of the SAR averaged over any 1 gram of tissue (defined as a tissue volume in the shape of a cube) and over the appropriate averaging time.
2. The Spatial Average value of the SAR averaged over the whole body.
3. The Spatial Peak value of the SAR averaged over any 10 grams of tissue (defined as a tissue volume in the shape of a cube) and over the appropriate averaging time.

FCC ID: ZNFH871	 PCTEST ENGINEERING LABORATORY, INC.	SAR EVALUATION REPORT	 LG	Approved by: Quality Manager
Document S/N: 1M1701180032-01-R4.ZNF	Test Dates: 01/20/17 - 01/30/17	DUT Type: Portable Handset		Page 20 of 97

8 FCC MEASUREMENT PROCEDURES

Power measurements for licensed transmitters are performed using a base station simulator under digital average power.

8.1 Measured and Reported SAR

Per FCC KDB Publication 447498 D01v06, when SAR is not measured at the maximum power level allowed for production units, the results must be scaled to the maximum tune-up tolerance limit according to the power applied to the individual channels tested to determine compliance. For simultaneous transmission, the measured aggregate SAR must be scaled according to the sum of the differences between the maximum tune-up tolerance and actual power used to test each transmitter. When SAR is measured at or scaled to the maximum tune-up tolerance limit, the results are referred to as *reported* SAR. The highest *reported* SAR results are identified on the grant of equipment authorization according to procedures in KDB 690783 D01v01r03.

8.2 3G SAR Test Reduction Procedure

In FCC KDB Publication 941225 D01v03r01, certain transmission modes within a frequency band and wireless mode evaluated for SAR are defined as primary modes. The equivalent modes considered for SAR test reduction are denoted as secondary modes. When the maximum output power including tune-up tolerance specified for production units in a secondary mode is ≤ 0.25 dB higher than the primary mode or when the highest reported SAR of the primary mode, scaled by the ratio of specified maximum output power and tune-up tolerance of secondary to primary mode, is ≤ 1.2 W/kg, SAR measurements are not required for the secondary mode. These criteria are referred to as the 3G SAR test reduction procedure. When the 3G SAR test reduction procedure is not satisfied, SAR measurements are additionally required for the secondary mode.

8.3 Procedures Used to Establish RF Signal for SAR



The following procedures are according to FCC KDB Publication 941225 D01v03r01 “3G SAR Measurement Procedures.”

The device is placed into a simulated call using a base station simulator in a RF shielded chamber. Establishing connections in this manner ensure a consistent means for testing SAR and are recommended for evaluating SAR [4]. Devices under test are evaluated prior to testing, with a fully charged battery and were configured to operate at maximum output power. In order to verify that the device is tested throughout the SAR test at maximum output power, the SAR measurement system measures a “point SAR” at an arbitrary reference point at the start and end of the 1 gram SAR evaluation, to assess for any power drifts during the evaluation. If the power drift deviates by more than 5%, the SAR test and drift measurements are repeated.

8.4 SAR Measurement Conditions for UMTS

8.4.1 Output Power Verification

Maximum output power is verified on the High, Middle and Low channels according to the general descriptions in section 5.2 of 3GPP TS 34.121, using the appropriate RMC with TPC (transmit power control) set to all “1s” or applying the required inner loop power control procedures to maintain maximum output power while HSUPA is active. Results for all applicable physical channel configurations (DPCCH, DPDCHn and spreading codes, HS-DPCCH etc) are tabulated in this test report. All configurations that are not supported by the DUT or cannot be measured due to technical or equipment limitations are identified.

FCC ID: ZNFH871	 PCTEST PROFESSIONAL LABORATORY, INC.	SAR EVALUATION REPORT	 LG	Approved by: Quality Manager
Document S/N: 1M1701180032-01-R4.ZNF	Test Dates: 01/20/17 - 01/30/17	DUT Type: Portable Handset		Page 21 of 97

8.4.2 Head SAR Measurements

SAR for next to the ear head exposure is measured using a 12.2 kbps RMC with TPC bits configured to all “1’s”. The 3G SAR test reduction procedure is applied to AMR configurations with 12.2 kbps RMC as the primary mode. Otherwise, SAR is measured for 12.2 kbps AMR in 3.4 kbps SRB (signaling radio bearer) using the highest reported SAR configuration in 12.2 kbps RMC for head exposure.

8.4.3 Body SAR Measurements

SAR for body exposure configurations is measured using the 12.2 kbps RMC with the TPC bits all “1s”. The 3G SAR test reduction procedure is applied to other spreading codes and multiple DPDCH_n configurations supported by the handset with 12.2 kbps RMC as the primary mode. Otherwise, SAR is measured using an applicable RMC configuration with the corresponding spreading code or DPDCH_n, for the highest reported SAR configuration in 12.2 kbps RMC.

8.4.4 SAR Measurements with Rel 5 HSDPA

The 3G SAR test reduction procedure is applied to HSDPA body configurations with 12.2 kbps RMC as the primary mode. Otherwise, Body SAR for HSDPA is measured using an FRC with H-Set 1 in Sub-test 1 and a 12.2 kbps RMC configured in Test Loop Mode 1, for the highest reported SAR configuration in 12.2 kbps RMC without HSDPA. Handsets with both HSDPA and HSUPA are tested according to Release 6 HSPA test procedures.

8.4.5 SAR Measurements with Rel 6 HSUPA

The 3G SAR test reduction procedure is applied to HSPA (HSUPA/HSDPA with RMC) body configurations with 12.2 kbps RMC as the primary mode. Otherwise, Body SAR for HSPA is measured with E-DCH Sub-test 5, using H-Set 1 and QPSK for FRC and a 12.2 kbps RMC configured in Test Loop Mode 1 and power control algorithm 2, according to the highest reported body SAR configuration in 12.2 kbps RMC without HSPA.

When VOIP applies to head exposure, the 3G SAR test reduction procedure is applied with 12.2 kbps RMC as the primary mode; otherwise, the same HSPA configuration used for body SAR measurements are applied to head exposure testing.

8.4.6 SAR Measurement Conditions for DC-HSDPA



SAR is required for Rel. 8 DC-HSDPA when SAR is required for Rel. 5 HSDPA; otherwise, the 3G SAR test reduction procedure is applied to DC-HSDPA with 12.2 kbps RMC as the primary mode. Power is measured for DC-HSDPA according to the H-Set 12, FRC configuration in Table C.8.1.12 of 3GPP TS 34.121-1 to determine SAR test reduction. A primary and a secondary serving HS-DSCH Cell are required to perform the power measurement and for the results to be acceptable.

8.5 SAR Measurement Conditions for LTE

LTE modes are tested according to FCC KDB 941225 D05v02r04 publication. Establishing connections with base station simulators ensure a consistent means for testing SAR and are recommended for evaluating SAR [4]. The R&S CMW500 or Anritsu MT8820C simulators are used for LTE output power measurements and SAR testing. Closed loop power control was used so the UE transmits with maximum output power during SAR testing. SAR tests were performed with the same number of RB and RB offsets transmitting on all TTI frames (maximum TTI).

8.5.1 Spectrum Plots for RB Configurations

A properly configured base station simulator was used for SAR tests and power measurements. Therefore, spectrum plots for RB configurations were not required to be included in this report.

FCC ID: ZNFH871	 PCTEST PROFESSIONAL LABORATORY, INC.	SAR EVALUATION REPORT	 LG	Approved by: Quality Manager
Document S/N: 1M1701180032-01-R4.ZNF	Test Dates: 01/20/17 - 01/30/17	DUT Type: Portable Handset		Page 22 of 97

8.5.2 MPR

MPR is permanently implemented for this device by the manufacturer. The specific manufacturer target MPR is indicated alongside the SAR results. MPR is enabled for this device, according to 3GPP TS36.101 Section 6.2.3 – 6.2.5 under Table 6.2.3-1.

8.5.3 A-MPR

A-MPR (Additional MPR) has been disabled for all SAR tests by setting NS=01 on the base station simulator.



8.5.4 Required RB Size and RB Offsets for SAR Testing

According to FCC KDB 941225 D05v02r04:

- a. Per Section 5.2.1, SAR is required for QPSK 1 RB Allocation for the largest bandwidth
 - i. The required channel and offset combination with the highest maximum output power is required for SAR.
 - ii. When the reported SAR is ≤ 0.8 W/kg, testing of the remaining RB offset configurations and required test channels is not required. Otherwise, SAR is required for the remaining required test channels using the RB offset configuration with highest output power for that channel.
 - iii. When the reported SAR for a required test channel is > 1.45 W/kg, SAR is required for all RB offset configurations for that channel.
- b. Per Section 5.2.2, SAR is required for 50% RB allocation using the largest bandwidth following the same procedures outlined in Section 5.2.1.
- c. Per Section 5.2.3, QPSK SAR is not required for the 100% allocation when the highest maximum output power for the 100% allocation is less than the highest maximum output power of the 1 RB and 50% RB allocations and the reported SAR for the 1 RB and 50% RB allocations is < 0.8 W/kg.
- d. Per Section 5.2.4 and 5.3, SAR tests for higher order modulations and lower bandwidths configurations are not required when the conducted power of the required test configurations determined by Sections 5.2.1 through 5.2.3 is less than or equal to $\frac{1}{2}$ dB higher than the equivalent configuration using QPSK modulation and when the QPSK SAR for those configurations is < 1.45 W/kg.

8.5.5 Downlink Only Carrier Aggregation

Conducted power measurements with LTE Carrier Aggregation (CA) (downlink only) active are made in accordance to KDB Publication 941225 D05Av01r02. The RRC connection is only handled by one cell, the primary component carrier (PCC) for downlink and uplink communications. After making a data connection to the PCC, the UE device adds secondary component carrier(s) (SCC) on the downlink only. All uplink communications and acknowledgements remain identical to specifications when downlink carrier aggregation is inactive on the PCC. For every supported combination of downlink only carrier aggregation, additional conducted output powers are measured with the downlink carrier aggregation active for the configuration with highest measured maximum conducted power with downlink carrier aggregation inactive measured among the channel bandwidth, modulation, and RB combinations in each frequency band. Per FCC KDB Publication 941225 D05Av01r02, no SAR measurements are required for carrier aggregation configurations when the average output power with downlink only carrier aggregation active is not more than 0.25 dB higher than the average output power with downlink only carrier aggregation inactive.

FCC ID: ZNFH871	 PCTEST ENGINEERING LABORATORY, INC.	SAR EVALUATION REPORT	 LG	Approved by: Quality Manager
Document S/N: 1M1701180032-01-R4.ZNF	Test Dates: 01/20/17 - 01/30/17	DUT Type: Portable Handset		Page 23 of 97

8.6 SAR Testing with 802.11 Transmitters

The normal network operating configurations of 802.11 transmitters are not suitable for SAR measurements. Unpredictable fluctuations in network traffic and antenna diversity conditions can introduce undesirable variations in SAR results. The SAR for these devices should be measured using chipset based test mode software to ensure the results are consistent and reliable. See KDB Publication 248227 D01v02r02 for more details.

8.6.1 General Device Setup

Chipset based test mode software is hardware dependent and generally varies among manufacturers. The device operating parameters established in test mode for SAR measurements must be identical to those programmed in production units, including output power levels, amplifier gain settings and other RF performance tuning parameters.

A periodic duty factor is required for current generation SAR systems to measure SAR. When 802.11 frame gaps are accounted for in the transmission, a maximum transmission duty factor of 92 - 96% is typically achievable in most test mode configurations. A minimum transmission duty factor of 85% is required to avoid certain hardware and device implementation issues related to wide range SAR scaling. The reported SAR is scaled to 100% transmission duty factor to determine compliance at the maximum tune-up tolerance limit.

8.6.2 U-NII-1 and U-NII-2A

For devices that operate in both U-NII-1 and U-NII-2A bands, when the same maximum output power is specified for both bands, SAR measurement using OFDM SAR test procedures is not required for U-NII-1 unless the highest reported SAR for U-NII-2A is > 1.2 W/kg. When different maximum output powers are specified for the bands, SAR measurement for the U-NII band with the lower maximum output power is not required unless the highest reported SAR for the U-NII band with the higher maximum output power, adjusted by the ratio of lower to higher specified maximum output power for the two bands, is > 1.2 W/kg.

8.6.3 U-NII-2C and U-NII-3



The frequency range covered by U-NII-2C and U-NII-3 is 380 MHz (5.47 – 5.85 GHz), which requires a minimum of at least two SAR probe calibration frequency points to support SAR measurements. When Terminal Doppler Weather Radar (TDWR) restriction applies, the channels at 5.60 – 5.65 GHz in U-NII-2C band must be disabled with acceptable mechanisms and documented in the equipment certification. Unless band gap channels are permanently disabled, SAR must be considered for these channels. Each band is tested independently according to the normally required OFDM SAR measurement and probe calibration frequency points requirements.

8.6.4 Initial Test Position Procedure

For exposure conditions with multiple test positions, such as handset operating next to the ear, devices with hotspot mode or UMPC mini-tablet, procedures for initial test position can be applied. Using the transmission mode determined by the DSSS procedure or initial test configuration, area scans are measured for all positions in an exposure condition. The test position with the highest extrapolated (peak) SAR is used as the initial test position. When reported SAR for the initial test position is ≤ 0.4 W/kg, no additional testing for the remaining test positions is required. Otherwise, SAR is evaluated at the subsequent highest peak SAR positions until the reported SAR result is ≤ 0.8 W/kg or all test positions are measured.

8.6.5 2.4 GHz SAR Test Requirements

SAR is measured for 2.4 GHz 802.11b DSSS using either the fixed test position or, when applicable, the initial test position procedure. SAR test reduction is determined according to the following:

FCC ID: ZNFH871		SAR EVALUATION REPORT		Approved by: Quality Manager
Document S/N: 1M1701180032-01-R4.ZNF	Test Dates: 01/20/17 - 01/30/17	DUT Type: Portable Handset		Page 24 of 97

- 1) When the reported SAR of the highest measured maximum output power channel for the exposure configuration is ≤ 0.8 W/kg, no further SAR testing is required for 802.11b DSSS in that exposure configuration.
- 2) When the reported SAR is > 0.8 W/kg, SAR is required for that position using the next highest measured output power channel. When any reported SAR is > 1.2 W/kg, SAR is required for the third channel; i.e., all channels require testing.

2.4 GHz 802.11 g/n OFDM are additionally evaluated for SAR if the highest reported SAR for 802.11b, adjusted by the ratio of the OFDM to DSSS specified maximum output power, is > 1.2 W/kg. When SAR is required for OFDM modes in 2.4 GHz band, the Initial Test Configuration Procedures should be followed.

8.6.6 OFDM Transmission Mode and SAR Test Channel Selection

When the same maximum output power was specified for multiple OFDM transmission mode configurations in a frequency band or aggregated band, SAR is measured using the configuration with the largest channel bandwidth, lowest order modulation and lowest data rate. When the maximum output power of a channel is the same for equivalent OFDM configurations; for example, 802.11a, 802.11n and 802.11ac or 802.11g and 802.11n with the same channel bandwidth, modulation and data rate etc., the lower order 802.11 mode i.e., 802.11a, then 802.11n and 802.11ac or 802.11g then 802.11n, is used for SAR measurement. When the maximum output power are the same for multiple test channels, either according to the default or additional power measurement requirements, SAR is measured using the channel closest to the middle of the frequency band or aggregated band. When there are multiple channels with the same maximum output power, SAR is measured using the higher number channel.



8.6.7 Initial Test Configuration Procedure

For OFDM, an initial test configuration is determined for each frequency band and aggregated band, according to the transmission mode with the highest maximum output power specified for SAR measurements. When the same maximum output power is specified for multiple OFDM transmission mode configurations in a frequency band or aggregated band, SAR is measured using the configuration(s) with the largest channel bandwidth, lowest order modulation, lowest data rate and lowest order IEEE 802.11 mode. The channel of the transmission mode with the highest average RF output conducted power will be the initial test configuration.

When the reported SAR is ≤ 0.8 W/kg, no additional measurements on other test channels are required. Otherwise, SAR is evaluated using the subsequent highest average RF output channel until the reported SAR result is ≤ 1.2 W/kg or all channels are measured. When there are multiple untested channels having the same subsequent highest average RF output power, the channel with higher frequency from the lowest 802.11 mode is considered for SAR measurements (See Section 8.6.6).



8.6.8 Subsequent Test Configuration Procedures

For OFDM configurations in each frequency band and aggregated band, SAR is evaluated for initial test configuration using the fixed test position or the initial test position procedure. When the highest reported SAR (for the initial test configuration), adjusted by the ratio of the specified maximum output power of the subsequent test configuration to initial test configuration, is ≤ 1.2 W/kg, no additional SAR tests for the subsequent test configurations are required.

FCC ID: ZNFH871		SAR EVALUATION REPORT		Approved by: Quality Manager
Document S/N: 1M1701180032-01-R4.ZNF	Test Dates: 01/20/17 - 01/30/17	DUT Type: Portable Handset		Page 25 of 97

8.6.9 MIMO SAR considerations

Per KDB Publication 248227 D01v02r02, the simultaneous SAR provisions in KDB Publication 447498 D01v06 should be applied to determine simultaneous transmission SAR test exclusion for WIFI MIMO. If the sum of 1g single transmission chain SAR measurements is <1.6 W/kg, no additional SAR measurements for MIMO are required. Alternatively, SAR for MIMO can be measured with all antennas transmitting simultaneously at the specified maximum output power of MIMO operation.

FCC ID: ZNFH871		SAR EVALUATION REPORT		Approved by: Quality Manager
Document S/N: 1M1701180032-01-R4.ZNF	Test Dates: 01/20/17 - 01/30/17	DUT Type: Portable Handset	Page 26 of 97	

9 RF CONDUCTED POWERS

9.1 GSM Conducted Powers



Maximum Burst-Averaged Output Power										
Band	Channel	Voice	GPRS/EDGE Data (GMSK)				EDGE Data (8-PSK)			
		GSM [dBm] CS (1 Slot)	GPRS [dBm] 1 Tx Slot	GPRS [dBm] 2 Tx Slot	GPRS [dBm] 3 Tx Slot	GPRS [dBm] 4 Tx Slot	EDGE [dBm] 1 Tx Slot	EDGE [dBm] 2 Tx Slot	EDGE [dBm] 3 Tx Slot	EDGE [dBm] 4 Tx Slot
GSM 850	128	33.15	33.12	32.05	30.14	28.55	27.14	27.15	26.67	26.51
	190	33.20	33.20	32.19	30.20	28.67	27.20	27.20	26.70	26.59
	251	33.12	33.13	32.18	30.20	28.70	27.10	27.19	26.64	26.55
GSM 1900	512	30.66	30.66	29.16	27.18	25.67	26.20	26.10	25.70	25.65
	661	30.67	30.67	29.13	27.20	25.70	26.13	26.05	25.67	25.64
	810	30.55	30.52	29.18	27.11	25.70	26.10	26.04	25.66	25.62

Calculated Maximum Frame-Averaged Output Power										
Band	Channel	Voice	GPRS/EDGE Data (GMSK)				EDGE Data (8-PSK)			
		GSM [dBm] CS (1 Slot)	GPRS [dBm] 1 Tx Slot	GPRS [dBm] 2 Tx Slot	GPRS [dBm] 3 Tx Slot	GPRS [dBm] 4 Tx Slot	EDGE [dBm] 1 Tx Slot	EDGE [dBm] 2 Tx Slot	EDGE [dBm] 3 Tx Slot	EDGE [dBm] 4 Tx Slot
GSM 850	128	24.12	24.09	26.03	25.88	25.54	18.11	21.13	22.41	23.50
	190	24.17	24.17	26.17	25.94	25.66	18.17	21.18	22.44	23.58
	251	24.09	24.10	26.16	25.94	25.69	18.07	21.17	22.38	23.54
GSM 1900	512	21.63	21.63	23.14	22.92	22.66	17.17	20.08	21.44	22.64
	661	21.64	21.64	23.11	22.94	22.69	17.10	20.03	21.41	22.63
	810	21.52	21.49	23.16	22.85	22.69	17.07	20.02	21.40	22.61

GSM 850	Frame	23.67	23.67	25.68	25.44	25.19	17.67	20.68	21.94	23.19
GSM 1900	Avg. Targets:	21.17	21.17	22.68	22.44	22.19	16.67	19.68	20.94	22.19

Note:



- Both burst-averaged and calculated frame-averaged powers are included. Frame-averaged power was calculated from the measured burst-averaged power by converting the slot powers into linear units and calculating the energy over 8 timeslots.
- GPRS/EDGE (GMSK) output powers were measured with coding scheme setting of 1 (CS1) on the base station simulator. CS1 was configured to measure GPRS output power measurements and SAR to ensure GMSK modulation in the signal. Our Investigation has shown that CS1 - CS4 settings do not have any impact on the output levels or modulation in the GPRS modes.
- EDGE (8-PSK) output powers were measured with MCS7 on the base station simulator. MCS7 coding scheme was used to measure the output powers for EDGE since investigation has shown that choosing MCS7 coding scheme will ensure 8-PSK modulation. It has been shown that MCS levels that produce 8PSK modulation do not have an impact on output power.

FCC ID: ZNFH871	 PCTEST PROFESSIONAL LABORATORY, INC.	SAR EVALUATION REPORT	 LG	Approved by: Quality Manager
Document S/N: 1M1701180032-01-R4.ZNF	Test Dates: 01/20/17 - 01/30/17	DUT Type: Portable Handset		Page 27 of 97

GSM Class: B
GPRS Multislot class: 12 (Max 4 Tx uplink slots)
EDGE Multislot class: 12 (Max 4 Tx uplink slots)
DTM Multislot Class: N/A



Figure 9-1
Power Measurement Setup

FCC ID: ZNFH871	 SAR EVALUATION REPORT 		Approved by: Quality Manager
Document S/N: 1M1701180032-01-R4.ZNF	Test Dates: 01/20/17 - 01/30/17	DUT Type: Portable Handset	Page 28 of 97

9.2 UMTS Conducted Powers

3GPP Release Version	Mode	3GPP 34.121 Subtest	Cellular Band [dBm]			AWS Band [dBm]			PCS Band [dBm]			3GPP MPR [dB]
			4132	4183	4233	1312	1412	1513	9262	9400	9538	
99	WCDMA	12.2 kbps RMC	24.65	24.65	24.70	24.96	24.98	24.90	24.97	25.00	24.95	-
99		12.2 kbps AMR	24.66	24.70	24.70	24.98	25.00	24.93	24.90	24.99	24.94	-
6	HSDPA	Subtest 1	24.66	24.70	24.66	24.93	25.00	24.93	24.95	24.97	25.00	0
6		Subtest 2	24.64	24.70	24.65	24.93	25.00	25.00	24.93	24.97	24.95	0
6		Subtest 3	24.12	24.15	24.12	24.35	24.40	24.34	24.20	24.30	24.30	0.5
6		Subtest 4	24.10	24.15	24.17	24.45	24.47	24.48	24.46	24.47	24.50	0.5
6	HSUPA	Subtest 1	24.55	24.60	24.56	24.90	24.94	24.90	24.90	24.94	24.90	0
6		Subtest 2	22.60	22.50	22.60	22.84	22.70	22.74	22.92	23.00	22.90	2
6		Subtest 3	23.55	23.52	23.53	23.80	23.85	23.85	23.87	23.80	23.76	1
6		Subtest 4	22.58	22.50	22.60	22.70	22.74	22.67	22.90	23.00	22.90	2
6		Subtest 5	24.61	24.60	24.62	24.90	24.94	24.97	24.90	24.92	24.94	0
8	DC-HSDPA	Subtest 1	24.65	24.63	24.59	24.90	24.94	24.96	24.94	24.98	24.96	0
8		Subtest 2	24.57	24.66	24.69	24.87	24.96	24.88	24.90	24.96	24.96	0
8		Subtest 3	24.20	24.16	24.14	24.38	24.41	24.34	24.20	24.30	24.28	0.5
8		Subtest 4	24.12	24.08	24.13	24.37	24.40	24.47	24.45	24.49	24.45	0.5

DC-HSDPA considerations

- 3GPP Specification 34.121-1 Release 8 Ver 8.10.0 was used for DC-HSDPA guidance
- H-Set 12 (QPSK) was confirmed to be used during DC-HSDPA measurements
- The DUT supports UE category 24 for HSDPA

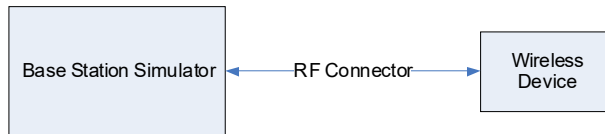



Figure 9-2
Power Measurement Setup

FCC ID: ZNFH871		SAR EVALUATION REPORT		Approved by: Quality Manager
Document S/N: 1M1701180032-01-R4.ZNF	Test Dates: 01/20/17 - 01/30/17	DUT Type: Portable Handset	Page 29 of 97	

9.1 LTE Conducted Powers

9.1.1 LTE Band 12



Table 9-1
LTE Band 12 Conducted Powers - 10 MHz Bandwidth

LTE Band 12 10 MHz Bandwidth					
Modulation	RB Size	RB Offset	Mid Channel	MPR Allowed per 3GPP [dB]	MPR [dB]
			23095 (707.5 MHz)		
			Conducted Power [dBm]		
QPSK	1	0	25.50	0	0
	1	25	25.48		0
	1	49	25.49		0
	25	0	24.45	0-1	1
	25	12	24.46		1
	25	25	24.48		1
16QAM	50	0	24.47		1
	1	0	24.48	0-1	1
	1	25	24.48		1
	1	49	24.47		1
	25	0	23.47	0-2	2
	25	12	23.45		2
25	25	23.46	2		
64QAM	50	0	23.48		2
	1	0	23.50	0-2	2
	1	25	23.30		2
	1	49	23.21		2
	25	0	22.28	0-3	3
	25	12	22.24		3
25	25	22.30	3		
	50	0	22.21		3

Note: LTE Band 12 at 10 MHz bandwidth does not support three non-overlapping channels. Per KDB Publication 941225 D05v02, when a device supports overlapping channel assignment in a channel bandwidth configuration, the middle channel of the group of overlapping channels should be selected for testing.

Table 9-2
LTE Band 12 Conducted Powers - 5 MHz Bandwidth

LTE Band 12 5 MHz Bandwidth							
Modulation	RB Size	RB Offset	Low Channel	Mid Channel	High Channel	MPR Allowed per 3GPP [dB]	MPR [dB]
			23035 (701.5 MHz)	23095 (707.5 MHz)	23155 (713.5 MHz)		
			Conducted Power [dBm]				
QPSK	1	0	25.43	25.44	25.43	0	0
	1	12	25.43	25.43	25.42		0
	1	24	25.46	25.40	25.44		0
	12	0	24.43	24.43	24.46	0-1	1
	12	6	24.44	24.43	24.42		1
	12	13	24.44	24.44	24.48		1
16QAM	25	0	24.44	24.45	24.44		1
	1	0	24.43	24.43	24.44	0-1	1
	1	12	24.40	24.43	24.44		1
	1	24	24.43	24.40	24.43		1
	12	0	23.42	23.43	23.43	0-2	2
	12	6	23.40	23.40	23.44		2
12	13	23.43	23.43	23.44	2		
64QAM	25	0	23.44	23.43	23.48		2
	1	0	23.50	23.45	23.46	0-2	2
	1	12	23.37	23.47	23.38		2
	1	24	23.46	23.49	23.20		2
	12	0	22.43	22.50	22.46	0-3	3
	12	6	22.40	22.37	22.46		3
12	13	22.48	22.45	22.42	3		
	25	0	22.41	22.35	22.40		3



FCC ID: ZNFH871		SAR EVALUATION REPORT		Approved by: Quality Manager
Document S/N: 1M1701180032-01-R4.ZNF	Test Dates: 01/20/17 - 01/30/17	DUT Type: Portable Handset		Page 30 of 97

**Table 9-3
LTE Band 12 Conducted Powers - 3 MHz Bandwidth**

LTE Band 12 3 MHz Bandwidth							
Modulation	RB Size	RB Offset	Low Channel	Mid Channel	High Channel	MPR Allowed per 3GPP [dB]	MPR [dB]
			23025 (700.5 MHz)	23095 (707.5 MHz)	23165 (714.5 MHz)		
			Conducted Power [dBm]				
QPSK	1	0	25.43	25.43	25.44	0	0
	1	7	25.42	25.43	25.45		0
	1	14	25.43	25.43	25.43		0
	8	0	24.42	24.44	24.45	0-1	1
	8	4	24.43	24.43	24.45		1
	8	7	24.42	24.41	24.44		1
	15	0	24.42	24.43	24.45		1
16QAM	1	0	24.43	24.44	24.43	0-1	1
	1	7	24.44	24.42	24.41		1
	1	14	24.42	24.46	24.43		1
	8	0	23.44	23.44	23.43	0-2	2
	8	4	23.44	23.43	23.43		2
	8	7	23.44	23.43	23.45		2
	15	0	23.46	23.42	23.43		2
64QAM	1	0	23.50	23.44	23.44	0-2	2
	1	7	23.49	23.45	23.41		2
	1	14	23.46	23.37	23.45		2
	8	0	22.50	22.41	22.40	0-3	3
	8	4	22.40	22.41	22.40		3
	8	7	22.46	22.35	22.45		3
	15	0	22.46	22.36	22.42		3

**Table 9-4
LTE Band 12 Conducted Powers -1.4 MHz Bandwidth**

LTE Band 12 1.4 MHz Bandwidth							
Modulation	RB Size	RB Offset	Low Channel	Mid Channel	High Channel	MPR Allowed per 3GPP [dB]	MPR [dB]
			23017 (699.7 MHz)	23095 (707.5 MHz)	23173 (715.3 MHz)		
			Conducted Power [dBm]				
QPSK	1	0	25.40	25.42	25.42	0	0
	1	2	25.38	25.40	25.42		0
	1	5	25.40	25.42	25.41		0
	3	0	25.41	25.42	25.41		0
	3	2	25.41	25.43	25.40		0
	3	3	25.42	25.43	25.41		0
	6	0	24.32	24.40	24.44	0-1	1
16QAM	1	0	24.30	24.43	24.42	0-1	1
	1	2	24.32	24.40	24.42		1
	1	5	24.30	24.41	24.43		1
	3	0	24.32	24.41	24.40		1
	3	2	24.30	24.40	24.42		1
	3	3	24.32	24.41	24.42		1
	6	0	23.33	23.42	23.43	0-2	2
64QAM	1	0	23.29	23.50	23.41	0-2	2
	1	2	23.40	23.42	23.38		2
	1	5	23.27	23.33	23.37		2
	3	0	23.30	23.38	23.41		2
	3	2	23.36	23.45	23.46		2
	3	3	23.37	23.48	23.46		2
	6	0	22.43	22.43	22.36	0-3	3

FCC ID: ZNFH871	 PCTEST <small>PROFESSIONAL LABORATORY, INC.</small>	SAR EVALUATION REPORT	 LG	Approved by: Quality Manager
Document S/N: 1M1701180032-01-R4.ZNF	Test Dates: 01/20/17 - 01/30/17	DUT Type: Portable Handset	Page 31 of 97	

9.1.2

LTE Band 13



Table 9-5
LTE Band 13 Conducted Powers - 10 MHz Bandwidth

LTE Band 13 10 MHz Bandwidth					
Modulation	RB Size	RB Offset	Mid Channel	MPR Allowed per 3GPP [dB]	MPR [dB]
			23230 (782.0 MHz)		
			Conducted Power [dBm]		
QPSK	1	0	25.20	0	0
	1	25	25.14		0
	1	49	25.15		0
	25	0	24.14	0-1	1
	25	12	24.16		1
	25	25	24.14		1
16QAM	50	0	24.11	0-1	1
	1	0	24.14		1
	1	25	24.15		1
	1	49	24.14	0-2	1
	25	0	23.15		2
	25	12	23.17		2
64QAM	25	25	23.17	0-2	2
	50	0	23.19		2
	1	0	23.18		2
	1	25	23.27	0-3	2
	1	49	22.80		2
	25	0	22.20		3
64QAM	25	12	22.17	0-3	3
	25	25	22.02		3
	50	0	22.14		3

Table 9-6
LTE Band 13 Conducted Powers - 5 MHz Bandwidth

LTE Band 13 5 MHz Bandwidth					
Modulation	RB Size	RB Offset	Mid Channel	MPR Allowed per 3GPP [dB]	MPR [dB]
			23230 (782.0 MHz)		
			Conducted Power [dBm]		
QPSK	1	0	25.15	0	0
	1	12	25.10		0
	1	24	25.10		0
	12	0	24.12	0-1	1
	12	6	24.13		1
	12	13	24.12		1
16QAM	25	0	24.11	0-1	1
	1	0	24.10		1
	1	12	24.10		1
	1	24	24.12	0-2	1
	12	0	23.10		2
	12	6	23.13		2
64QAM	12	13	23.14	0-2	2
	25	0	23.14		2
	1	0	23.06		0-2
	1	12	23.16	2	
	1	24	23.09	2	
	64QAM	12	0	22.00	0-3
12		6	22.06	3	
12		13	21.95	3	
25		0	21.99	3	

Note: LTE Band 13 at 5 MHz bandwidth does not support three non-overlapping channels. Per KDB Publication 941225 D05v02, when a device supports overlapping channel assignment in a channel bandwidth configuration, the middle channel of the group of overlapping channels should be selected for testing.

FCC ID: ZNFH871		SAR EVALUATION REPORT		Approved by: Quality Manager
Document S/N: 1M1701180032-01-R4.ZNF	Test Dates: 01/20/17 - 01/30/17	DUT Type: Portable Handset		Page 32 of 97

9.1.3

LTE Band 5 (Cell)



Table 9-7
LTE Band 5 (Cell) Conducted Powers - 10 MHz Bandwidth

LTE Band 5 (Cell) 10 MHz Bandwidth					
Modulation	RB Size	RB Offset	Mid Channel	MPR Allowed per 3GPP [dB]	MPR [dB]
			20525 (836.5 MHz)		
			Conducted Power [dBm]		
QPSK	1	0	25.50	0	0
	1	25	25.47		0
	1	49	25.48		0
	25	0	24.45	0-1	1
	25	12	24.47		1
	25	25	24.45		1
	50	0	24.44		1
16QAM	1	0	24.45	0-1	1
	1	25	24.48		1
	1	49	24.45		1
	25	0	23.45	0-2	2
	25	12	23.46		2
	25	25	23.49		2
	50	0	23.50		2
64QAM	1	0	23.33	0-2	2
	1	25	23.18		2
	1	49	23.25		2
	25	0	22.40	0-3	3
	25	12	22.31		3
	25	25	22.33		3
	50	0	21.90		3

Note: LTE Band 5 (Cell) at 10 MHz bandwidth does not support three non-overlapping channels. Per KDB Publication 941225 D05v02, when a device supports overlapping channel assignment in a channel bandwidth configuration, the middle channel of the group of overlapping channels should be selected for testing.

Table 9-8
LTE Band 5 (Cell) Conducted Powers - 5 MHz Bandwidth

LTE Band 5 (Cell) 5 MHz Bandwidth							
Modulation	RB Size	RB Offset	Low Channel	Mid Channel	High Channel	MPR Allowed per 3GPP [dB]	MPR [dB]
			20425 (826.5 MHz)	20525 (836.5 MHz)	20625 (846.5 MHz)		
			Conducted Power [dBm]				
QPSK	1	0	25.46	25.44	25.43	0	0
	1	12	25.48	25.43	25.44		0
	1	24	25.46	25.40	25.44		0
	12	0	24.43	24.50	24.46	0-1	1
	12	6	24.45	24.43	24.40		1
	12	13	24.44	24.48	24.48		1
	25	0	24.44	24.47	24.44		1
16QAM	1	0	24.49	24.43	24.43	0-1	1
	1	12	24.40	24.46	24.44		1
	1	24	24.43	24.40	24.40		1
	12	0	23.40	23.45	23.43	0-2	2
	12	6	23.40	23.40	23.44		2
	12	13	23.43	23.48	23.45		2
	25	0	23.44	23.43	23.49		2
64QAM	1	0	23.49	23.31	23.40	0-2	2
	1	12	23.39	23.40	23.43		2
	1	24	23.43	23.43	23.44		2
	12	0	22.43	22.43	22.41	0-3	3
	12	6	22.39	22.39	22.42		3
	12	13	22.39	22.46	22.45		3
	25	0	22.35	22.15	22.49		3



FCC ID: ZNFH871		SAR EVALUATION REPORT		Approved by: Quality Manager
Document S/N: 1M1701180032-01-R4.ZNF	Test Dates: 01/20/17 - 01/30/17	DUT Type: Portable Handset		Page 33 of 97

**Table 9-9
LTE Band 5 (Cell) Conducted Powers - 3 MHz Bandwidth**

LTE Band 5 (Cell) 3 MHz Bandwidth							
Modulation	RB Size	RB Offset	Low Channel	Mid Channel	High Channel	MPR Allowed per 3GPP [dB]	MPR [dB]
			20415 (825.5 MHz)	20525 (836.5 MHz)	20635 (847.5 MHz)		
			Conducted Power [dBm]				
QPSK	1	0	25.47	25.47	25.48	0	0
	1	7	25.49	25.47	25.45		0
	1	14	25.48	25.44	25.46		0
	8	0	24.45	24.45	24.45	0-1	1
	8	4	24.44	24.47	24.45		1
	8	7	24.45	24.43	24.46		1
	15	0	24.44	24.46	24.45		1
16QAM	1	0	24.46	24.48	24.44	0-1	1
	1	7	24.44	24.45	24.41		1
	1	14	24.40	24.46	24.45		1
	8	0	23.44	23.45	23.43	0-2	2
	8	4	23.43	23.43	23.44		2
	8	7	23.47	23.46	23.45		2
	15	0	23.46	23.44	23.44		2
64QAM	1	0	23.41	23.40	23.48	0-2	2
	1	7	23.39	23.47	23.37		2
	1	14	23.39	23.43	23.46		2
	8	0	22.46	22.40	22.36	0-3	3
	8	4	22.50	22.46	22.40		3
	8	7	22.48	22.39	22.31		3
	15	0	22.41	22.33	22.49		3

**Table 9-10
LTE Band 5 (Cell) Conducted Powers -1.4 MHz Bandwidth**

LTE Band 5 (Cell) 1.4 MHz Bandwidth							
Modulation	RB Size	RB Offset	Low Channel	Mid Channel	High Channel	MPR Allowed per 3GPP [dB]	MPR [dB]
			20407 (824.7 MHz)	20525 (836.5 MHz)	20643 (848.3 MHz)		
			Conducted Power [dBm]				
QPSK	1	0	25.47	25.46	25.45	0	0
	1	2	25.45	25.41	25.47		0
	1	5	25.45	25.47	25.40		0
	3	0	25.47	25.46	25.41		0
	3	2	25.46	25.45	25.42		0
	3	3	25.46	25.46	25.40		0
	6	0	24.35	24.43	24.44	0-1	1
16QAM	1	0	24.35	24.45	24.44	0-1	1
	1	2	24.35	24.43	24.45		1
	1	5	24.34	24.40	24.43		1
	3	0	24.35	24.41	24.41		1
	3	2	24.37	24.42	24.42		1
	3	3	24.34	24.41	24.45		1
	6	0	23.36	23.45	23.45	0-2	2
64QAM	1	0	23.43	23.34	23.40	0-2	2
	1	2	23.42	23.33	23.48		2
	1	5	23.32	23.39	23.41		2
	3	0	23.35	23.40	23.39		2
	3	2	23.39	23.33	23.42		2
	3	3	23.41	23.34	23.46		2
	6	0	22.39	22.45	22.45		0-3

FCC ID: ZNFH871	 PCTEST <small>PROFESSIONAL LABORATORY, INC.</small>	SAR EVALUATION REPORT	 LG	Approved by: Quality Manager
Document S/N: 1M1701180032-01-R4.ZNF	Test Dates: 01/20/17 - 01/30/17	DUT Type: Portable Handset	Page 34 of 97	

9.1.4

LTE Band 66 (AWS)

Table 9-11
LTE Band 66 (AWS) Conducted Powers - 20 MHz Bandwidth

LTE Band 66 (AWS) 20 MHz Bandwidth							
Modulation	RB Size	RB Offset	Low Channel	Mid Channel	High Channel	MPR Allowed per 3GPP [dB]	MPR [dB]
			132072 (1720.0 MHz)	132322 (1745.0 MHz)	132572 (1770.0 MHz)		
			Conducted Power [dBm]				
QPSK	1	0	25.40	25.44	25.48	0	0
	1	50	25.30	25.46	25.49		0
	1	99	25.50	25.13	25.46		0
	50	0	24.45	24.50	24.48	0-1	1
	50	25	24.45	24.48	24.47		1
	50	50	24.44	24.43	24.47		1
16QAM	100	0	24.46	24.46	24.48	0-1	1
	1	0	24.45	24.43	24.45		1
	1	50	24.43	24.45	24.46		1
	1	99	24.45	24.47	24.47	0-2	1
	50	0	23.46	23.49	23.45		2
	50	25	23.48	23.45	23.46		2
64QAM	50	50	23.50	23.46	23.48	0-2	2
	100	0	23.50	23.49	23.46		2
	1	0	23.43	23.39	23.45		0-2
	1	50	23.35	23.49	23.45	2	
	1	99	23.38	23.40	23.49	2	
	64QAM	50	0	22.42	22.47	22.46	0-3
50		25	22.20	22.38	22.40	3	
50		50	22.16	22.41	22.38	3	
100		0	22.44	22.40	22.36	3	

Table 9-12
LTE Band 66 (AWS) Conducted Powers - 15 MHz Bandwidth

LTE Band 66 (AWS) 15 MHz Bandwidth								
Modulation	RB Size	RB Offset	Low Channel	Mid Channel	High Channel	MPR Allowed per 3GPP [dB]	MPR [dB]	
			132047 (1717.5 MHz)	132322 (1745.0 MHz)	132597 (1772.5 MHz)			
			Conducted Power [dBm]					
QPSK	1	0	25.49	25.48	25.46	0	0	
	1	36	25.50	25.47	25.47		0	
	1	74	25.50	25.50	25.46		0	
	16QAM	36	0	24.43	24.45	24.48	0-1	1
		36	18	24.44	24.44	24.45		1
		36	37	24.45	24.46	24.47		1
		75	0	24.45	24.47	24.47		1
64QAM	1	0	24.47	24.48	24.45	0-1	1	
	1	36	24.43	24.45	24.45		1	
	1	74	24.43	24.47	24.50		1	
	16QAM	36	0	23.47	23.46	23.48	0-2	2
		36	18	23.45	23.47	23.46		2
		36	37	23.45	23.47	23.48		2
64QAM	75	0	23.45	23.46	23.46	0-2	2	
	1	0	23.47	23.42	23.40		2	
	1	36	23.30	23.46	23.47		2	
	16QAM	1	74	23.46	23.43	23.16	0-3	2
		36	0	22.48	22.22	22.49		3
		36	18	22.47	22.43	22.38		3
		36	37	22.46	22.42	22.47		3
75	0	22.50	22.41	22.50	3			



FCC ID: ZNFH871		SAR EVALUATION REPORT		Approved by: Quality Manager
Document S/N: 1M1701180032-01-R4.ZNF	Test Dates: 01/20/17 - 01/30/17	DUT Type: Portable Handset		Page 35 of 97

Table 9-13
LTE Band 66 (AWS) Conducted Powers - 10 MHz Bandwidth

LTE Band 66 (AWS) 10 MHz Bandwidth							
Modulation	RB Size	RB Offset	Low Channel	Mid Channel	High Channel	MPR Allowed per 3GPP [dB]	MPR [dB]
			132022 (1715.0 MHz)	132322 (1745.0 MHz)	132622 (1775.0 MHz)		
			Conducted Power [dBm]				
QPSK	1	0	25.46	25.49	25.46	0	0
	1	25	25.47	25.48	25.43		0
	1	49	25.48	25.50	25.42		0
	25	0	24.48	24.45	24.40	0-1	1
	25	12	24.43	24.48	24.43		1
	25	25	24.47	24.45	24.45		1
	50	0	24.48	24.43	24.44		1
16QAM	1	0	24.45	24.46	24.46	0-1	1
	1	25	24.48	24.48	24.46		1
	1	49	24.48	24.48	24.45		1
	25	0	23.47	23.45	23.43	0-2	2
	25	12	23.46	23.44	23.45		2
	25	25	23.48	23.43	23.45		2
	50	0	23.44	23.45	23.44		2
64QAM	1	0	23.46	23.45	23.47	0-2	2
	1	25	23.45	23.43	23.43		2
	1	49	23.42	23.49	23.41		2
	25	0	22.48	22.35	22.41	0-3	3
	25	12	22.48	22.37	22.47		3
	25	25	22.41	22.48	22.42		3
	50	0	22.44	22.48	22.37		3

Table 9-14
LTE Band 66 (AWS) Conducted Powers - 5 MHz Bandwidth

LTE Band 66 (AWS) 5 MHz Bandwidth							
Modulation	RB Size	RB Offset	Low Channel	Mid Channel	High Channel	MPR Allowed per 3GPP [dB]	MPR [dB]
			131997 (1712.5 MHz)	132322 (1745.0 MHz)	132647 (1777.5 MHz)		
			Conducted Power [dBm]				
QPSK	1	0	25.48	25.46	25.46	0	0
	1	12	25.49	25.43	25.46		0
	1	24	25.48	25.41	25.44		0
	12	0	24.43	24.50	24.46	0-1	1
	12	6	24.45	24.48	24.44		1
	12	13	24.44	24.48	24.48		1
	25	0	24.48	24.47	24.44		1
16QAM	1	0	24.49	24.48	24.46	0-1	1
	1	12	24.45	24.46	24.48		1
	1	24	24.43	24.45	24.40		1
	12	0	23.40	23.45	23.47	0-2	2
	12	6	23.43	23.46	23.44		2
	12	13	23.43	23.48	23.48		2
	25	0	23.44	23.44	23.47		2
64QAM	1	0	23.46	23.48	23.40	0-2	2
	1	12	23.20	23.50	23.22		2
	1	24	23.45	23.44	23.43		2
	12	0	22.40	22.47	22.47	0-3	3
	12	6	22.34	22.43	22.46		3
	12	13	22.39	22.43	22.13		3
	25	0	22.37	22.49	22.40		3



FCC ID: ZNFH871		SAR EVALUATION REPORT		Approved by: Quality Manager
Document S/N: 1M1701180032-01-R4.ZNF	Test Dates: 01/20/17 - 01/30/17	DUT Type: Portable Handset		Page 36 of 97



Table 9-15
LTE Band 66 (AWS) Conducted Powers - 3 MHz Bandwidth

LTE Band 66 (AWS) 3 MHz Bandwidth							
Modulation	RB Size	RB Offset	Low Channel	Mid Channel	High Channel	MPR Allowed per 3GPP [dB]	MPR [dB]
			131987 (1711.5 MHz)	132322 (1745.0 MHz)	132657 (1778.5 MHz)		
			Conducted Power [dBm]				
QPSK	1	0	25.47	25.46	25.48	0	0
	1	7	25.48	25.47	25.43		0
	1	14	25.48	25.46	25.49		0
	8	0	24.43	24.45	24.45	0-1	1
	8	4	24.45	24.46	24.48		1
	8	7	24.43	24.43	24.44		1
	15	0	24.46	24.46	24.45		1
16QAM	1	0	24.50	24.48	24.43	0-1	1
	1	7	24.44	24.49	24.41		1
	1	14	24.46	24.46	24.43		1
	8	0	23.45	23.46	23.45	0-2	2
	8	4	23.43	23.43	23.44		2
	8	7	23.46	23.45	23.46		2
	15	0	23.46	23.44	23.46		2
64QAM	1	0	23.47	23.42	23.35	0-2	2
	1	7	23.40	23.47	23.45		2
	1	14	23.46	23.39	23.38		2
	8	0	22.45	22.50	22.44	0-3	3
	8	4	22.42	22.48	22.33		3
	8	7	22.40	22.45	22.50		3
	15	0	22.35	22.45	22.50		3

Table 9-16
LTE Band 66 (AWS) Conducted Powers – 1.4 MHz Bandwidth

LTE Band 66 (AWS) 1.4 MHz Bandwidth								
Modulation	RB Size	RB Offset	Low Channel	Low-Mid Channel	Mid-High	High Channel	MPR Allowed per 3GPP [dB]	MPR [dB]
			131979 (1710.7 MHz)	132208 (1733.6 MHz)	132436 (1756.4 MHz)	132665 (1779.3 MHz)		
			Conducted Power [dBm]					
QPSK	1	0	25.39	25.35	25.36	25.43	0	0
	1	2	25.33	25.44	25.37	25.45		0
	1	5	25.42	25.36	25.45	25.34		0
	3	0	25.35	25.40	25.46	25.36		0
	3	2	25.41	25.30	25.37	25.36		0
	3	3	25.44	25.30	25.41	25.35		0
	6	0	24.40	24.35	24.41	24.32	0-1	1
16QAM	1	0	24.41	24.32	24.42	24.37	0-1	1
	1	2	24.42	24.34	24.37	24.45		1
	1	5	24.39	24.38	24.33	24.34		1
	3	0	24.39	24.31	24.34	24.29		1
	3	2	24.31	24.40	24.38	24.33		1
	3	3	24.39	24.44	24.38	24.38		1
	6	0	23.42	23.39	23.35	23.38	0-2	2
64QAM	1	0	23.34	23.20	23.41	23.34	0-2	2
	1	2	23.37	23.32	23.38	23.50		2
	1	5	23.41	23.46	23.42	23.33		2
	3	0	23.41	23.24	23.32	23.36		2
	3	2	23.24	23.42	23.26	23.34		2
	3	3	23.40	23.40	23.32	23.37		2
	6	0	22.45	22.42	22.38	22.44	0-3	3

Per FCC KDB Publication 447498 D01v06 Section 4.1g), 4 channels are required for LTE Band 66 with 1.4 MHz Bandwidth.

FCC ID: ZNFH871	 PCTEST <small>ENGINEERING LABORATORY, INC.</small>	SAR EVALUATION REPORT	 LG	Approved by: Quality Manager
Document S/N: 1M1701180032-01-R4.ZNF	Test Dates: 01/20/17 - 01/30/17	DUT Type: Portable Handset		Page 37 of 97

9.1.5

LTE Band 25 (PCS)

Table 9-17
LTE Band 25 (PCS) Conducted Powers - 20 MHz Bandwidth

LTE Band 25 (PCS) 20 MHz Bandwidth								
Modulation	RB Size	RB Offset	Low Channel	Mid Channel	High Channel	MPR Allowed per 3GPP [dB]	MPR [dB]	
			26140 (1860.0 MHz)	26365 (1882.5 MHz)	26590 (1905.0 MHz)			
			Conducted Power [dBm]					
QPSK	1	0	24.66	25.00	24.95	0	0	
	1	50	24.98	24.90	24.97		0	
	1	99	24.97	24.95	24.80		0	
	50	0	23.99	24.00	23.98	0-1	1	
	50	25	23.95	23.95	23.97		1	
	50	50	23.95	23.88	23.84		1	
16QAM	100	0	23.90	23.97	23.99	0-1	1	
	1	0	23.98	24.00	24.00		1	
	1	50	23.97	23.94	24.00		1	
	1	99	23.98	24.00	24.00	0-2	1	
	50	0	23.00	23.00	22.98		2	
	50	25	22.93	22.97	22.94		2	
64QAM	50	50	22.95	22.98	23.00	0-2	2	
	100	0	23.00	23.00	22.98		2	
	1	0	22.85	22.90	22.93		0-2	2
	1	50	22.92	22.95	22.97	2		
	1	99	22.68	22.90	22.85	2		
	64QAM	50	0	21.70	21.99	21.93	0-3	3
		50	25	22.00	21.97	21.90		3
		50	50	21.94	21.87	22.00		3
100		0	21.85	21.93	21.92	0-3	3	
50		0	21.70	21.99	21.93		3	
50		25	22.00	21.97	21.90		3	

Table 9-18
LTE Band 25 (PCS) Conducted Powers - 15 MHz Bandwidth

LTE Band 25 (PCS) 15 MHz Bandwidth								
Modulation	RB Size	RB Offset	Low Channel	Mid Channel	High Channel	MPR Allowed per 3GPP [dB]	MPR [dB]	
			26115 (1857.5 MHz)	26365 (1882.5 MHz)	26615 (1907.5 MHz)			
			Conducted Power [dBm]					
QPSK	1	0	25.00	24.97	24.96	0	0	
	1	36	24.95	24.94	24.98		0	
	1	74	24.97	24.98	24.94		0	
	QPSK	36	0	23.95	23.93	23.96	0-1	1
		36	18	23.30	23.93	23.98		1
		36	37	23.92	23.95	23.93		1
		75	0	23.94	23.97	23.95		1
1		0	23.95	23.96	23.94	0-1		1
16QAM	1	36	23.93	23.97	23.97		1	
	1	74	23.94	23.95	23.94		1	
	36	0	22.94	22.94	22.94	0-2	2	
	36	18	22.93	22.96	22.95		2	
	36	37	22.95	22.97	22.94		2	
	64QAM	75	0	22.94	22.98	22.96	0-2	2
1		0	22.85	22.93	22.85	2		
1		36	22.95	22.94	22.88	2		
64QAM		1	74	22.91	22.89	22.85	0-3	2
		36	0	21.87	21.89	21.90		3
		36	18	21.95	21.93	21.89		3
		36	37	21.94	21.88	21.96		3
		75	0	21.87	21.96	21.91		3



FCC ID: ZNFH871		SAR EVALUATION REPORT		Approved by: Quality Manager
Document S/N: 1M1701180032-01-R4.ZNF	Test Dates: 01/20/17 - 01/30/17	DUT Type: Portable Handset		Page 38 of 97

Table 9-19
LTE Band 25 (PCS) Conducted Powers - 10 MHz Bandwidth

LTE Band 25 (PCS) 10 MHz Bandwidth							
Modulation	RB Size	RB Offset	Low Channel	Mid Channel	High Channel	MPR Allowed per 3GPP [dB]	MPR [dB]
			26090 (1855.0 MHz)	26365 (1882.5 MHz)	26640 (1910.0 MHz)		
			Conducted Power [dBm]				
QPSK	1	0	24.93	24.94	24.96	0	0
	1	25	24.96	24.96	24.93		0
	1	49	24.95	24.96	24.94		0
	25	0	23.93	23.90	23.96	0-1	1
	25	12	23.92	23.90	23.94		1
	25	25	23.94	23.91	23.95		1
16QAM	50	0	23.96	23.95	23.94	0-1	1
	1	0	23.93	23.95	24.00		1
	1	25	23.94	23.96	23.94		1
	1	49	23.95	23.94	23.94	0-2	1
	25	0	22.94	22.93	22.95		2
	25	12	22.95	22.94	23.00		2
64QAM	25	25	22.94	22.93	23.00	0-2	2
	50	0	22.94	22.96	23.00		2
	1	0	22.88	22.97	22.93		0-3
	1	25	22.87	22.95	22.82	2	
	1	49	22.92	22.89	22.91	2	
	25	0	21.64	21.78	21.80	0-3	3
25	12	21.97	21.89	21.96	3		
25	25	21.88	21.96	21.96	3		
50	0	21.84	21.96	21.99		3	

Table 9-20
LTE Band 25 (PCS) Conducted Powers - 5 MHz Bandwidth

LTE Band 25 (PCS) 5 MHz Bandwidth							
Modulation	RB Size	RB Offset	Low Channel	Mid Channel	High Channel	MPR Allowed per 3GPP [dB]	MPR [dB]
			26065 (1852.5 MHz)	26365 (1882.5 MHz)	26665 (1912.5 MHz)		
			Conducted Power [dBm]				
QPSK	1	0	24.83	24.97	24.93	0	0
	1	12	25.00	24.96	24.99		0
	1	24	24.93	24.94	24.93		0
	12	0	23.94	23.93	23.95	0-1	1
	12	6	23.96	23.95	23.94		1
	12	13	23.94	23.94	23.95		1
16QAM	25	0	23.94	23.93	23.93	0-1	1
	1	0	24.00	23.95	24.00		1
	1	12	23.93	23.95	23.93		1
	1	24	23.94	23.94	23.94	0-2	1
	12	0	23.00	23.00	23.00		2
	12	6	22.94	22.94	22.94		2
64QAM	12	13	22.95	22.93	22.94	0-2	2
	25	0	22.94	22.95	23.00		2
	1	0	22.50	22.87	22.97		0-3
	1	12	23.00	22.88	22.95	2	
	1	24	22.92	22.91	22.99	2	
	12	0	22.00	21.98	21.66	0-3	3
12	6	21.89	21.88	21.94	3		
12	13	21.88	21.92	21.86	3		
25	0	21.97	21.96	21.92		3	





FCC ID: ZNFH871	 PCTEST ENGINEERING LABORATORY, INC.	SAR EVALUATION REPORT	 LG	Approved by: Quality Manager
Document S/N: 1M1701180032-01-R4.ZNF	Test Dates: 01/20/17 - 01/30/17	DUT Type: Portable Handset		Page 39 of 97

Table 9-21
LTE Band 25 (PCS) Conducted Powers - 3 MHz Bandwidth

LTE Band 25 (PCS) 3 MHz Bandwidth							
Modulation	RB Size	RB Offset	Low Channel	Mid Channel	High Channel	MPR Allowed per 3GPP [dB]	MPR [dB]
			26055 (1851.5 MHz)	26365 (1882.5 MHz)	26675 (1913.5 MHz)		
			Conducted Power [dBm]				
QPSK	1	0	24.98	24.97	24.97	0	0
	1	7	24.95	25.00	24.97		0
	1	14	24.95	24.94	24.93		0
	8	0	23.95	23.95	23.94	0-1	1
	8	4	23.95	23.93	23.97		1
	8	7	23.97	23.97	23.94		1
16QAM	15	0	23.94	23.93	23.94	0-1	1
	1	0	23.93	24.00	23.93		1
	1	7	23.96	23.94	23.94		1
	1	14	23.98	23.85	23.97	0-2	1
	8	0	23.00	23.00	23.00		2
	8	4	22.95	22.92	22.97		2
64QAM	8	7	23.00	23.00	22.94	0-2	2
	15	0	22.98	22.94	23.00		2
	1	0	22.98	22.99	22.88		0-2
	1	7	23.00	22.97	22.96	2	
	1	14	22.95	22.76	22.92	2	
	64QAM	8	0	21.90	21.95	21.96	0-3
8		4	21.96	21.91	21.97	3	
8		7	21.97	21.96	21.94	3	
15		0	21.89	22.00	21.96	0-3	3

Table 9-22
LTE Band 25 (PCS) Conducted Powers - 1.4 MHz Bandwidth

LTE Band 25 (PCS) 1.4 MHz Bandwidth								
Modulation	RB Size	RB Offset	Low Channel	Mid Channel	High Channel	MPR Allowed per 3GPP [dB]	MPR [dB]	
			26047 (1850.7 MHz)	26365 (1882.5 MHz)	26683 (1914.3 MHz)			
			Conducted Power [dBm]					
QPSK	1	0	24.97	24.97	24.93	0	0	
	1	2	24.97	24.95	24.97		0	
	1	5	24.93	24.91	24.94		0	
	3	0	24.96	24.94	24.85	0-1	0	
	3	2	24.95	24.93	24.94		0	
	3	3	24.93	24.95	24.92		0	
16QAM	6	0	23.93	23.85	23.94	0-1	1	
	1	0	23.94	23.94	23.93		0-1	1
	1	2	23.94	23.96	24.00			1
	1	5	23.93	23.97	23.94	0-1		1
	3	0	23.89	23.98	23.95		1	
	3	2	23.99	23.99	23.96		1	
64QAM	3	3	23.96	23.94	23.97	0-2	1	
	6	0	22.80	23.00	23.00		2	
	1	0	22.94	22.91	22.90		0-2	2
	1	2	22.93	22.99	22.90	2		
	1	5	22.83	22.94	22.98	2		
	3	0	22.83	22.93	22.89	0-2	2	
3	2	22.96	22.97	22.89	2			
3	3	22.98	22.92	22.89	2			
64QAM	6	0	21.86	21.85	21.68	0-3	3	

FCC ID: ZNFH871	 PCTEST ENGINEERING LABORATORY, INC.	SAR EVALUATION REPORT	 LG	Approved by: Quality Manager
Document S/N: 1M1701180032-01-R4.ZNF	Test Dates: 01/20/17 - 01/30/17	DUT Type: Portable Handset	Page 40 of 97	

9.1.6

LTE Band 30



Table 9-23
LTE Band 30 Conducted Powers - 10 MHz Bandwidth

LTE Band 30 10 MHz Bandwidth					
Modulation	RB Size	RB Offset	Mid Channel	MPR Allowed per 3GPP [dB]	MPR [dB]
			27710 (2310.0 MHz) Conducted Power [dBm]		
QPSK	1	0	25.48	0	0
	1	25	25.47		0
	1	49	25.41		0
	25	0	24.47	0-1	1
	25	12	24.48		1
	25	25	24.47		1
16QAM	50	0	24.33	0-1	1
	1	0	24.48		1
	1	25	24.47		1
	1	49	24.47	0-2	2
	25	0	23.47		2
	25	12	23.48		2
64QAM	25	25	23.47	0-2	2
	50	0	23.48		2
	1	0	23.28		0-3
	1	25	23.19	2	
	1	49	23.20	2	
	25	0	22.06	0-3	3
25	12	22.16	3		
25	25	22.14	3		
50	0	21.95		3	

Table 9-24
LTE Band 30 Conducted Powers - 5 MHz Bandwidth

LTE Band 30 5 MHz Bandwidth						
Modulation	RB Size	RB Offset	Mid Channel	MPR Allowed per 3GPP [dB]	MPR [dB]	
			27710 (2310.0 MHz) Conducted Power [dBm]			
QPSK	1	0	25.50	0	0	
	1	12	25.48		0	
	1	24	25.47		0	
	12	0	24.47	0-1	1	
	12	6	24.46		1	
	12	13	24.48		1	
	25	0	24.49		1	
16QAM	1	0	24.48	0-1	1	
	1	12	24.47		1	
	1	24	24.48		1	
	12	0	23.46	0-2	2	
	12	6	23.47		2	
	12	13	23.47		2	
64QAM	25	0	23.47	0-2	2	
	1	0	23.30		0-2	2
	1	12	23.22			2
	1	24	23.14	0-3		2
	12	0	22.20		3	
	12	6	22.25		3	
	12	13	22.43		3	
25	0	22.32		3		

Note: LTE Band 30 at 5 MHz bandwidth does not support three non-overlapping channels. Per KDB Publication 941225 D05v02, when a device supports overlapping channel assignment in a channel bandwidth configuration, the middle channel of the group of overlapping channels should be selected for testing.

FCC ID: ZNFH871		SAR EVALUATION REPORT		Approved by: Quality Manager
Document S/N: 1M1701180032-01-R4.ZNF	Test Dates: 01/20/17 - 01/30/17	DUT Type: Portable Handset		Page 41 of 97

9.1.7



LTE Band 7

Table 9-25
LTE Band 7 Conducted Powers - 20 MHz Bandwidth

LTE Band 7 20 MHz Bandwidth								
Modulation	RB Size	RB Offset	Low Channel	Mid Channel	High Channel	MPR Allowed per 3GPP [dB]	MPR [dB]	
			20850 (2510.0 MHz)	21100 (2535.0 MHz)	21350 (2560.0 MHz)			
			Conducted Power [dBm]					
QPSK	1	0	25.46	25.48	25.50	0	0	
	1	50	25.46	25.40	25.49		0	
	1	99	25.47	25.40	25.46		0	
	QPSK	50	0	24.44	24.30	24.48	0-1	1
		50	25	24.45	24.49	24.48		1
		50	50	24.43	24.43	24.47		1
100		0	24.46	24.44	24.48	1		
16QAM	1	0	24.45	24.43	24.45	0-1	1	
	1	50	24.43	24.45	24.46		1	
	1	99	24.45	24.47	24.44		1	
	16QAM	50	0	23.44	23.49	23.45	0-2	2
		50	25	23.48	23.46	23.44		2
		50	50	23.00	23.46	23.45		2
64QAM	100	0	23.50	23.47	23.50	0-2	2	
	1	0	23.40	23.41	23.40		0-2	2
	1	50	23.36	23.34	23.30			2
	64QAM	1	99	23.40	23.43	23.44		0-3
		50	0	22.50	22.38	22.37	3	
		50	25	22.41	22.49	22.40	3	
50		50	21.94	22.39	22.37	3		
100	0	22.49	22.44	22.38	3			

Table 9-26
LTE Band 7 Conducted Powers - 15 MHz Bandwidth

LTE Band 7 15 MHz Bandwidth								
Modulation	RB Size	RB Offset	Low Channel	Mid Channel	High Channel	MPR Allowed per 3GPP [dB]	MPR [dB]	
			20825 (2507.5 MHz)	21100 (2535.0 MHz)	21375 (2562.5 MHz)			
			Conducted Power [dBm]					
QPSK	1	0	25.45	25.45	25.45	0	0	
	1	36	25.40	25.47	25.44		0	
	1	74	25.43	25.43	25.43		0	
	QPSK	36	0	24.43	24.45	24.40	0-1	1
		36	18	24.43	24.43	24.44		1
		36	37	24.45	24.46	24.47		1
75		0	24.43	24.45	24.43	1		
16QAM	1	0	24.47	24.44	24.44	0-1	1	
	1	36	24.44	24.45	24.45		1	
	1	74	24.43	24.44	24.43		1	
	16QAM	36	0	23.43	23.46	23.44	0-2	2
		36	18	23.45	23.45	23.45		2
		36	37	23.44	23.46	23.44		2
64QAM	75	0	23.45	23.44	23.45	0-2	2	
	1	0	23.45	23.35	23.42		0-2	2
	1	36	23.28	23.40	23.37			2
	64QAM	1	74	23.45	23.45	23.34		0-3
		36	0	22.37	22.40	22.49	3	
		36	18	22.38	22.31	22.34	3	
36		37	22.32	22.48	22.32	3		
75	0	22.35	22.50	22.46	3			



FCC ID: ZNFH871	 PCTEST ENGINEERING LABORATORY, INC.	SAR EVALUATION REPORT	 LG	Approved by: Quality Manager
Document S/N: 1M1701180032-01-R4.ZNF	Test Dates: 01/20/17 - 01/30/17	DUT Type: Portable Handset		Page 42 of 97

**Table 9-27
LTE Band 7 Conducted Powers - 10 MHz Bandwidth**

LTE Band 7 10 MHz Bandwidth							
Modulation	RB Size	RB Offset	Low Channel	Mid Channel	High Channel	MPR Allowed per 3GPP [dB]	MPR [dB]
			20800 (2505.0 MHz)	21100 (2535.0 MHz)	21400 (2565.0 MHz)		
			Conducted Power [dBm]				
QPSK	1	0	25.44	25.41	25.44	0	0
	1	25	25.44	25.43	25.43		0
	1	49	25.43	25.43	25.42		0
	25	0	24.44	24.42	24.43	0-1	1
	25	12	24.40	24.43	24.43		1
	25	25	24.42	24.45	24.43		1
16QAM	50	0	24.40	24.40	24.44	0-1	1
	1	0	24.45	24.46	24.44		1
	1	25	24.43	24.40	24.46		1
	1	49	24.45	24.48	24.43	0-2	1
	25	0	23.43	23.43	23.43		2
	25	12	23.45	23.44	23.42		2
64QAM	25	25	23.42	23.43	23.45	0-2	2
	50	0	23.43	23.45	23.43		2
	1	0	23.30	23.47	23.35		0-2
	1	25	23.31	23.27	23.29	2	
	1	49	23.49	23.49	23.46	2	
	64QAM	25	0	22.43	22.29	22.33	0-3
25		12	22.50	22.36	22.34	3	
25		25	22.34	22.42	22.33	3	
50		0	22.41	22.44	22.46	3	

**Table 9-28
LTE Band 7 Conducted Powers - 5 MHz Bandwidth**



LTE Band 7 5 MHz Bandwidth								
Modulation	RB Size	RB Offset	Low Channel	Mid Channel	High Channel	MPR Allowed per 3GPP [dB]	MPR [dB]	
			20775 (2502.5 MHz)	21100 (2535.0 MHz)	21425 (2567.5 MHz)			
			Conducted Power [dBm]					
QPSK	1	0	25.40	25.44	25.44	0	0	
	1	12	25.38	25.43	25.43		0	
	1	24	25.39	25.40	25.42		0	
	12	0	24.41	24.43	24.46	0-1	1	
	12	6	24.40	24.43	24.40		1	
	12	13	24.44	24.44	24.48		1	
16QAM	25	0	24.44	24.47	24.43	0-1	1	
	1	0	24.45	24.40	24.46		0-1	1
	1	12	24.43	24.46	24.40			1
	1	24	24.41	24.43	24.41	0-2		1
	12	0	23.40	23.44	23.43		2	
	12	6	23.43	23.46	23.44		2	
64QAM	12	13	23.43	23.43	23.43	0-2	2	
	25	0	23.42	23.43	23.44		2	
	1	0	23.49	23.33	23.38		0-2	2
	1	12	23.33	23.46	23.24	2		
	1	24	23.38	23.43	23.46	2		
	64QAM	12	0	22.38	22.42	22.42	0-3	3
12		6	22.36	22.37	22.41	3		
12		13	22.46	22.45	22.35	3		
25		0	22.45	22.34	22.37	3		

FCC ID: ZNFH871		SAR EVALUATION REPORT		Approved by: Quality Manager
Document S/N: 1M1701180032-01-R4.ZNF	Test Dates: 01/20/17 - 01/30/17	DUT Type: Portable Handset		Page 43 of 97

9.1.8 LTE Carrier Aggregation Conducted Powers

**Table 9-29
LTE Carrier Aggregation Conducted Powers 2CC Powers**

PCC									SCC				Power	
PCC Band	PCC Bandwidth [MHz]	PCC (UL) Channel	PCC (UL) Frequency [MHz]	Modulation	PCC UL# RB	PCC UL RB Offset	PCC (DL) Channel	PCC (DL) Frequency [MHz]	SCC Band	SCC Bandwidth [MHz]	SCC (DL) Channel	SCC (DL) Frequency [MHz]	LTE Tx.Power with DL CA Enabled (dBm)	LTE Single Carrier Tx.Power (dBm)
LTE B2	20	18925	1882.5	QPSK	1	0	925	1962.5	LTE B4	20	2175	2132.5	24.97	25.00
LTE B2	20	18925	1882.5	QPSK	1	0	925	1962.5	LTE B12	10	5095	737.5	24.87	25.00
LTE B2	20	18925	1882.5	QPSK	1	0	925	1962.5	LTE B29	10	9715	722.5	24.97	25.00
LTE B2	20	18925	1882.5	QPSK	1	0	925	1962.5	LTE B5	10	2525	881.5	24.92	25.00
LTE B2	20	18925	1882.5	QPSK	1	0	925	1962.5	LTE B30	10	9820	2355	24.95	25.00
LTE B4	20	20050	1720	QPSK	1	99	2050	2120	LTE B2	20	900	1960	25.44	25.50
LTE B12	10	23095	707.5	QPSK	1	0	5095	737.5	LTE B2	20	900	1960	25.46	25.50
LTE B5	10	20525	836.5	QPSK	1	0	2525	881.5	LTE B2	20	900	1960	25.41	25.50
LTE B30	5	27710	2310	QPSK	1	0	9820	2355	LTE B2	20	900	1960	25.33	25.50
LTE B4	20	20050	1720	QPSK	1	99	2050	2120	LTE B29	10	9715	722.5	25.36	25.50
LTE B4	20	20050	1720	QPSK	1	99	2050	2120	LTE B12	10	5095	737.5	25.49	25.50
LTE B4	20	20050	1720	QPSK	1	99	2050	2120	LTE B5	10	2525	881.5	25.50	25.50
LTE B4	20	20050	1720	QPSK	1	99	2050	2120	LTE B30	10	9820	2355	25.40	25.50
LTE B2	20	18925	1882.5	QPSK	1	0	925	1962.5	LTE B66	20	66786	2145	25.00	25.00
LTE B5	10	20525	836.5	QPSK	1	0	2525	881.5	LTE B66	20	66786	2145	25.46	25.50
LTE B12	10	23095	707.5	QPSK	1	0	5095	737.5	LTE B4	20	2175	2132.5	25.39	25.50
LTE B5	10	20525	836.5	QPSK	1	0	2525	881.5	LTE B4	20	2175	2132.5	25.40	25.50
LTE B30	5	27710	2310	QPSK	1	0	9820	2355	LTE B4	20	2175	2132.5	25.46	25.50
LTE B66	20	132072	1720	QPSK	1	99	66536	2120	LTE B2	20	900	1960	25.37	25.50
LTE B66	20	132072	1720	QPSK	1	99	66536	2120	LTE B5	10	2525	881.5	25.46	25.50
LTE B5	10	20525	836.5	QPSK	1	0	2525	881.5	LTE B30	10	9820	2355	25.45	25.50
LTE B12	10	23095	707.5	QPSK	1	0	5095	737.5	LTE B30	10	9820	2355	25.29	25.50
LTE B30	5	27710	2310	QPSK	1	0	9820	2355	LTE B29	10	9715	722.5	25.46	25.50
LTE B12	10	23095	707.5	QPSK	1	0	5095	737.5	LTE B66	20	66786	2145	25.44	25.50
LTE B30	5	27710	2310	QPSK	1	0	9820	2355	LTE B5	10	2525	881.5	25.50	25.50
LTE B30	5	27710	2310	QPSK	1	0	9820	2355	LTE B12	10	5095	737.5	25.50	25.50
LTE B66	20	132072	1720	QPSK	1	99	66536	2120	LTE B12	10	5095	737.5	25.50	25.50
LTE B2	5	18625	1852.5	QPSK	1	12	625	1932.5	LTE B17	10	5790	740	24.41	25.00
LTE B4	10	20300	1745	QPSK	1	49	2300	2145	LTE B17	10	5790	740	25.40	25.50
LTE B4	20	20050	1720	QPSK	1	99	2050	2120	LTE B7	20	3100	2655	25.41	25.50
LTE B17	10	23765	707.5	QPSK	1	0	5765	737.5	LTE B2	10	900	1960	25.48	25.50
LTE B17	10	23765	707.5	QPSK	1	0	5765	737.5	LTE B4	10	2175	2132.5	25.38	25.50
LTE B7	20	21350	2560	QPSK	1	0	3350	2680	LTE B4	20	2175	2132.5	25.34	25.50
LTE B7	20	21350	2560	QPSK	1	0	3350	2680	LTE B12	10	5095	737.5	25.48	25.50
LTE B12	10	23095	707.5	QPSK	1	0	5095	737.5	LTE B7	20	3100	2655	25.44	25.50
LTE B66	20	132072	1720	QPSK	1	99	66536	2120	LTE B66	20	66734	2139.8	25.33	25.50
LTE B4	20	20050	1720	QPSK	1	99	2050	2120	LTE B4	5	2375	2152.5	25.45	25.50
LTE B2	20	18925	1882.5	QPSK	1	0	925	1962.5	LTE B2	5	625	1932.5	24.98	25.00
LTE B7	20	21350	2560	QPSK	1	0	3350	2680	LTE B7	5	2775	2622.5	25.46	25.50
LTE B66	20	132072	1720	QPSK	1	99	66536	2120	LTE B66	5	67111	2177.5	25.42	25.50
LTE B66	15	132047	1717.5	QPSK	1	99	66511	2117.5	LTE B66	5	66610	2127.4	25.48	25.50

FCC ID: ZNFH871	 PCTEST ENGINEERING LABORATORY, INC.	SAR EVALUATION REPORT	 LG	Approved by: Quality Manager
Document S/N: 1M1701180032-01-R4.ZNF	Test Dates: 01/20/17 - 01/30/17	DUT Type: Portable Handset	Page 44 of 97	

**Table 9-30
LTE Carrier Aggregation Conducted Powers 3CC Powers**



PCC Band	PCC Bandwidth [MHz]	PCC (UL) Channel	PCC				SCC 1			SCC 2			Power					
			PCC (UL) Frequency [MHz]	Modulation	PCC UL/RB	PCC (DL) Channel	PCC (DL) Frequency [MHz]	SCC Band	SCC Bandwidth [MHz]	SCC (DL) Channel	SCC (DL) Frequency [MHz]	SCC Band	SCC Bandwidth [MHz]	SCC (DL) Channel	SCC (DL) Frequency [MHz]	LTE Tx Power with DL CA Enabled (dBm)	LTE Single Carrier Tx Power (dBm)	
LTE B2	20	18925	1882.5	QPSK	1	0	925	1962.5	LTE B29	10	9715	722.5	LTE B30	10	9820	2355	24.91	25.00
LTE B4	20	20050	1720	QPSK	1	99	2050	2120	LTE B29	10	9715	722.5	LTE B30	10	9820	2355	25.46	25.50
LTE B2	20	18925	1882.5	QPSK	1	0	925	1962.5	LTE B5	10	2525	881.5	LTE B30	10	9820	2355	24.86	25.00
LTE B4	20	20050	1720	QPSK	1	99	2050	2120	LTE B5	10	2525	881.5	LTE B30	10	9820	2355	25.45	25.50
LTE B2	20	18925	1882.5	QPSK	1	0	925	1962.5	LTE B12	10	5095	737.5	LTE B30	10	9820	2355	24.98	25.00
LTE B4	20	20050	1720	QPSK	1	99	2050	2120	LTE B12	10	5095	737.5	LTE B30	10	9820	2355	25.38	25.50
LTE B30	5	27710	2310	QPSK	1	0	9820	2355	LTE B2	20	900	1960	LTE B29	10	9715	722.5	25.39	25.50
LTE B30	5	27710	2310	QPSK	1	0	9820	2355	LTE B4	20	2175	2132.5	LTE B29	10	9715	722.5	25.42	25.50
LTE B5	10	20525	836.5	QPSK	1	0	2525	881.5	LTE B2	20	900	1960	LTE B30	10	9820	2355	25.44	25.50
LTE B5	10	20525	836.5	QPSK	1	0	2525	881.5	LTE B4	20	2175	2132.5	LTE B30	10	9820	2355	25.47	25.50
LTE B12	10	23095	707.5	QPSK	1	0	5095	737.5	LTE B2	20	900	1960	LTE B30	10	9820	2355	25.45	25.50
LTE B12	10	23095	707.5	QPSK	1	0	5095	737.5	LTE B4	20	2175	2132.5	LTE B30	10	9820	2355	25.43	25.50
LTE B30	5	27710	2310	QPSK	1	0	9820	2355	LTE B2	20	900	1960	LTE B5	10	2525	881.5	25.46	25.50
LTE B30	5	27710	2310	QPSK	1	0	9820	2355	LTE B4	20	2175	2132.5	LTE B5	10	2525	881.5	25.42	25.50
LTE B30	5	27710	2310	QPSK	1	0	9820	2355	LTE B2	20	900	1960	LTE B12	10	5095	737.5	25.39	25.50
LTE B30	5	27710	2310	QPSK	1	0	9820	2355	LTE B4	20	2175	2132.5	LTE B12	10	5095	737.5	25.36	25.50
LTE B2	20	18925	1882.5	QPSK	1	0	925	1962.5	LTE B4	20	2175	2132.5	LTE B12	10	5095	737.5	24.95	25.00
LTE B2	20	18925	1882.5	QPSK	1	0	925	1962.5	LTE B4	20	2175	2132.5	LTE B5	10	2525	881.5	24.94	25.00
LTE B2	20	18925	1882.5	QPSK	1	0	925	1962.5	LTE B2	5	625	1932.5	LTE B5	10	2525	881.5	24.95	25.00
LTE B2	20	18925	1882.5	QPSK	1	0	925	1962.5	LTE B2	5	625	1932.5	LTE B12	10	5095	737.5	24.91	25.00
LTE B4	20	20050	1720	QPSK	1	99	2050	2120	LTE B4	5	2375	2152.5	LTE B5	10	2525	881.5	25.38	25.50
LTE B4	20	20050	1720	QPSK	1	99	2050	2120	LTE B4	5	2375	2152.5	LTE B12	10	5095	737.5	25.44	25.50
LTE B4	20	20050	1720	QPSK	1	99	2050	2120	LTE B2	20	900	1960	LTE B12	10	5095	737.5	25.40	25.50
LTE B4	20	20050	1720	QPSK	1	99	2050	2120	LTE B2	20	900	1960	LTE B5	10	2525	881.5	25.43	25.50
LTE B5	10	20525	836.5	QPSK	1	0	2525	881.5	LTE B2	20	900	1960	LTE B2	5	625	1932.5	25.50	25.50
LTE B12	10	23095	707.5	QPSK	1	0	5095	737.5	LTE B2	20	900	1960	LTE B2	5	625	1932.5	25.36	25.50
LTE B5	10	20525	836.5	QPSK	1	0	2525	881.5	LTE B4	20	2175	2132.5	LTE B4	5	2375	2152.5	25.41	25.50
LTE B12	10	23095	707.5	QPSK	1	0	5095	737.5	LTE B4	20	2175	2132.5	LTE B4	5	2375	2152.5	25.43	25.50
LTE B12	10	23095	707.5	QPSK	1	0	5095	737.5	LTE B2	20	900	1960	LTE B4	20	2175	2132.5	25.46	25.50
LTE B5	10	20525	836.5	QPSK	1	0	2525	881.5	LTE B2	20	900	1960	LTE B4	20	2175	2132.5	25.37	25.50
LTE B12	10	23095	707.5	QPSK	1	0	5095	737.5	LTE B66	20	66786	2145	LTE B66	5	67111	2177.5	25.49	25.50
LTE B2	20	18925	1882.5	QPSK	1	0	925	1962.5	LTE B4	20	2175	2132.5	LTE B4	5	2375	2152.5	24.98	25.00
LTE B4	20	20050	1720	QPSK	1	99	2050	2120	LTE B7	20	3100	2655	LTE B12	10	5095	737.5	25.43	25.50
LTE B2	20	18925	1882.5	QPSK	1	0	925	1962.5	LTE B4	20	2175	2132.5	LTE B29	10	9715	722.5	24.95	25.00
LTE B66	20	132072	1720	QPSK	1	99	66536	2120	LTE B12	10	5095	737.5	LTE B66	5	67111	2177.5	25.42	25.50
LTE B4	20	20050	1720	QPSK	1	99	2050	2120	LTE B4	5	2375	2152.5	LTE B2	20	900	1960	25.38	25.50
LTE B7	20	21350	2560	QPSK	1	0	3350	2680	LTE B4	20	2175	2132.5	LTE B12	10	5095	737.5	25.38	25.50
LTE B4	20	20050	1720	QPSK	1	99	2050	2120	LTE B2	20	900	1960	LTE B29	10	9715	722.5	25.39	25.50
LTE B12	10	23095	707.5	QPSK	1	0	5095	737.5	LTE B4	20	2175	2132.5	LTE B7	20	3100	2655	25.37	25.50

Notes:

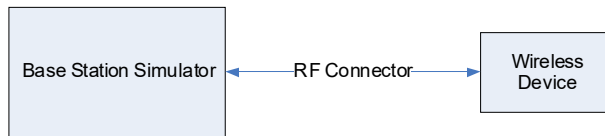
- The device only supports downlink Carrier Aggregation. Uplink Carrier Aggregation is not supported. For every supported combination of downlink carrier aggregation, power measurements were performed with the downlink carrier aggregation active for the configuration with highest measured maximum conducted power with downlink carrier aggregation inactive measured among the channel bandwidth, modulation, and RB combinations in each frequency band.
- All control and acknowledge data is sent on uplink channels that operate identical to specifications when downlink carrier aggregation is inactive.
- For downlink carrier aggregation combinations, PCC uplink channel was selected based on section C)3)b)ii) of KBD 941225 D05 V01r02. The downlink PCC channel was paired with the selected PCC uplink channel according to normal configurations without carrier aggregation. For inter-band CA, the SCC downlink channels were selected near the middle of their transmission bands. For contiguous intra-band CA, the downlink channel spacing between the component carriers was set to multiple of 300 kHz less than the nominal channel spacing defined in section 5.4.1A of 3GPP TS 36.521. For non-contiguous intra-band CA, the downlink channel spacing between the component carriers was set to be larger than the nominal channel spacing and provided maximum separation between the component carriers. All selected downlink channels remained fully within the downlink transmission band of the respective component carrier.
- Per FCC guidance LTE Band 12 standalone powers were used to select measurement configurations for LTE Band 17, LTE Band 66 standalone powers were used to select measurement configurations for LTE Band 4, and LTE B25 standalone SISO powers were used to select measurement configurations for LTE Band 2.



**Figure 9-3
Power Measurement Setup**

FCC ID: ZNFH871		SAR EVALUATION REPORT		Approved by: Quality Manager
Document S/N: 1M1701180032-01-R4.ZNF	Test Dates: 01/20/17 - 01/30/17	DUT Type: Portable Handset	Page 45 of 97	

9.2 WLAN Conducted Powers

Table 9-31
2.4 GHz WLAN Maximum Average RF Power – Primary Antenna

Freq [MHz]	Channel	2.4GHz Conducted Power [dBm]			
		IEEE Transmission Mode			
		802.11b	802.11g	802.11n	802.11ac
2412	1	18.02	15.05	15.03	15.02
2422	3	19.78	16.25	16.14	16.04
2437	6	19.81	16.28	16.15	16.13
2452	9	19.72	16.22	16.10	16.10
2462	11	18.11	15.23	15.16	15.06

Table 9-32
2.4 GHz WLAN Maximum Average RF Power – Secondary Antenna

Freq [MHz]	Channel	2.4GHz Conducted Power [dBm]			
		IEEE Transmission Mode			
		802.11b	802.11g	802.11n	802.11ac
2412	1	18.25	15.33	15.23	15.24
2422	3	18.51	15.50	15.55	15.43
2437	6	18.52	15.56	15.63	15.48
2452	9	18.51	15.51	15.62	15.40
2462	11	18.44	15.27	15.24	15.28

Table 9-33
2.4 GHz WLAN Reduced Average RF Power – Primary Antenna

Freq [MHz]	Channel	2.4GHz Conducted Power [dBm]			
		IEEE Transmission Mode			
		802.11b	802.11g	802.11n	802.11ac
2412	1	14.32	13.74	13.68	13.66
2422	3	15.42	14.94	14.96	14.79
2437	6	15.46	14.95	14.91	14.88
2452	9	15.45	14.97	14.94	14.85
2462	11	14.20	13.79	14.46	13.64

Table 9-34
2.4 GHz WLAN Reduced Average RF Power – Secondary Antenna

Freq [MHz]	Channel	2.4GHz Conducted Power [dBm]			
		IEEE Transmission Mode			
		802.11b	802.11g	802.11n	802.11ac
2412	1	14.96	14.62	14.46	14.33
2422	3	15.23	14.96	14.98	14.90
2437	6	15.31	14.95	14.96	14.90
2452	9	15.20	14.82	14.95	14.92
2462	11	14.95	14.51	14.48	14.31



FCC ID: ZNFH871		SAR EVALUATION REPORT		Approved by: Quality Manager
Document S/N: 1M1701180032-01-R4.ZNF	Test Dates: 01/20/17 - 01/30/17	DUT Type: Portable Handset		Page 46 of 97

Table 9-35
5 GHz WLAN Maximum Average RF Power – Primary Antenna

Freq [MHz]	Channel	5GHz (20MHz) Conducted Power [dBm]		
		IEEE Transmission Mode		
		802.11a	802.11n	802.11ac
5180	36	12.37	12.22	12.31
5200	40	16.18	16.09	15.96
5220	44	16.11	16.07	15.97
5240	48	16.04	16.09	16.02
5260	52	16.01	15.96	15.78
5280	56	15.89	15.88	15.81
5300	60	16.05	15.76	15.95
5320	64	12.02	12.04	12.11
5500	100	12.25	12.00	12.18
5580	116	15.86	15.86	15.79
5660	132	15.83	15.68	15.67
5720	144	15.76	15.67	15.56
5745	149	16.36	15.52	16.08
5785	157	15.95	16.01	15.85
5825	165	12.27	12.11	12.08

Table 9-36
5 GHz WLAN Maximum Average RF Power – Secondary Antenna

Freq [MHz]	Channel	5GHz (20MHz) Conducted Power [dBm]		
		IEEE Transmission Mode		
		802.11a	802.11n	802.11ac
5180	36	12.21	11.92	11.96
5200	40	15.96	15.87	15.68
5220	44	15.85	15.86	15.79
5240	48	15.97	15.90	15.87
5260	52	15.71	15.68	15.65
5280	56	15.76	15.71	15.59
5300	60	15.71	15.54	15.66
5320	64	11.88	11.68	11.72
5500	100	12.33	12.08	12.08
5580	116	15.85	15.83	15.82
5660	132	16.10	15.79	15.78
5720	144	15.63	15.51	15.53
5745	149	16.44	16.47	16.45
5785	157	16.06	16.00	15.83
5825	165	11.51	11.91	12.02





FCC ID: ZNFH871		SAR EVALUATION REPORT		Approved by: Quality Manager
Document S/N: 1M1701180032-01-R4.ZNF	Test Dates: 01/20/17 - 01/30/17	DUT Type: Portable Handset		Page 47 of 97

Table 9-37
5 GHz WLAN Reduced Average RF Power – Primary Antenna

Freq [MHz]	Channel	5GHz (20MHz) Conducted Power [dBm]		
		IEEE Transmission Mode		
		802.11a	802.11n	802.11ac
5180	36	12.37	12.22	12.31
5200	40	14.01	14.15	14.17
5220	44	14.04	14.28	14.31
5240	48	14.27	14.07	14.25
5260	52	14.12	14.09	14.09
5280	56	14.08	14.09	14.24
5300	60	14.14	14.19	14.20
5320	64	12.02	12.04	12.11
5500	100	12.25	12.00	12.18
5580	116	14.21	14.01	14.07
5660	132	13.91	13.88	13.76
5720	144	13.78	13.89	14.02
5745	149	14.01	14.11	14.28
5785	157	14.14	14.11	14.01
5825	165	12.27	12.11	12.08

Table 9-38
5 GHz WLAN Reduced Average RF Power – Secondary Antenna

Freq [MHz]	Channel	5GHz (20MHz) Conducted Power [dBm]		
		IEEE Transmission Mode		
		802.11a	802.11n	802.11ac
5180	36	12.21	11.92	11.96
5200	40	14.39	14.44	14.20
5220	44	14.46	14.31	14.49
5240	48	14.21	14.26	14.40
5260	52	14.41	14.22	14.23
5280	56	14.34	14.28	14.24
5300	60	14.38	14.27	14.23
5320	64	11.88	11.68	11.72
5500	100	12.33	12.08	12.08
5580	116	14.46	14.24	14.29
5660	132	13.83	13.99	13.97
5720	144	13.86	14.01	13.76
5745	149	14.32	14.45	14.46
5785	157	14.46	14.20	14.48
5825	165	11.51	11.91	12.02

FCC ID: ZNFH871		SAR EVALUATION REPORT		Approved by: Quality Manager
Document S/N: 1M1701180032-01-R4.ZNF	Test Dates: 01/20/17 - 01/30/17	DUT Type: Portable Handset		Page 48 of 97

Justification for test configurations for WLAN per KDB Publication 248227 D01v02r02:

- Power measurements were performed for the transmission mode configuration with the highest maximum output power specified for production units.
- For transmission modes with the same maximum output power specification, powers were measured for the largest channel bandwidth, lowest order modulation and lowest data rate.
- For transmission modes with identical maximum specified output power, channel bandwidth, modulation and data rates, power measurements were required for all identical configurations.
- For each transmission mode configuration, powers were measured for the highest and lowest channels; and at the mid-band channel(s) when there were at least 3 channels supported. For configurations with multiple mid-band channels, due to an even number of channels, both channels were measured.
- The bolded data rate and channel above were tested for SAR.

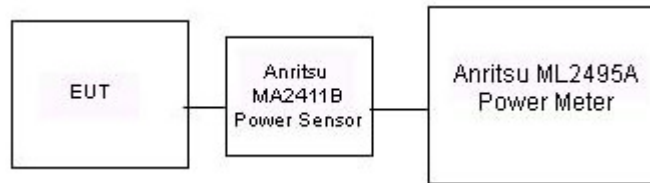



Figure 9-4
Power Measurement Setup

9.3 Bluetooth Conducted Powers and Duty Cycle Calculation

Table 9-39
Bluetooth Average RF Power

Frequency [MHz]	Data Rate [Mbps]	Channel No.	Avg Conducted Power	
			[dBm]	[mW]
2402	1.0	0	9.67	9.268
2441	1.0	39	10.65	11.612
2480	1.0	78	9.39	8.687
2402	2.0	0	7.86	6.105
2441	2.0	39	8.84	7.647
2480	2.0	78	7.61	5.773
2402	3.0	0	7.92	6.194
2441	3.0	39	8.92	7.805
2480	3.0	78	7.70	5.883

Note: The bolded data rate and channel above were tested for SAR.

FCC ID: ZNFH871	 PCTEST ENGINEERING LABORATORY, INC.	SAR EVALUATION REPORT	 LG	Approved by: Quality Manager
Document S/N: 1M1701180032-01-R4.ZNF	Test Dates: 01/20/17 - 01/30/17	DUT Type: Portable Handset		Page 49 of 97

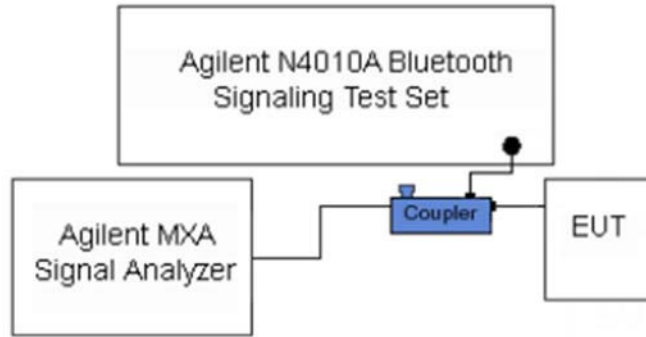

Figure 9-5
Power Measurement Setup

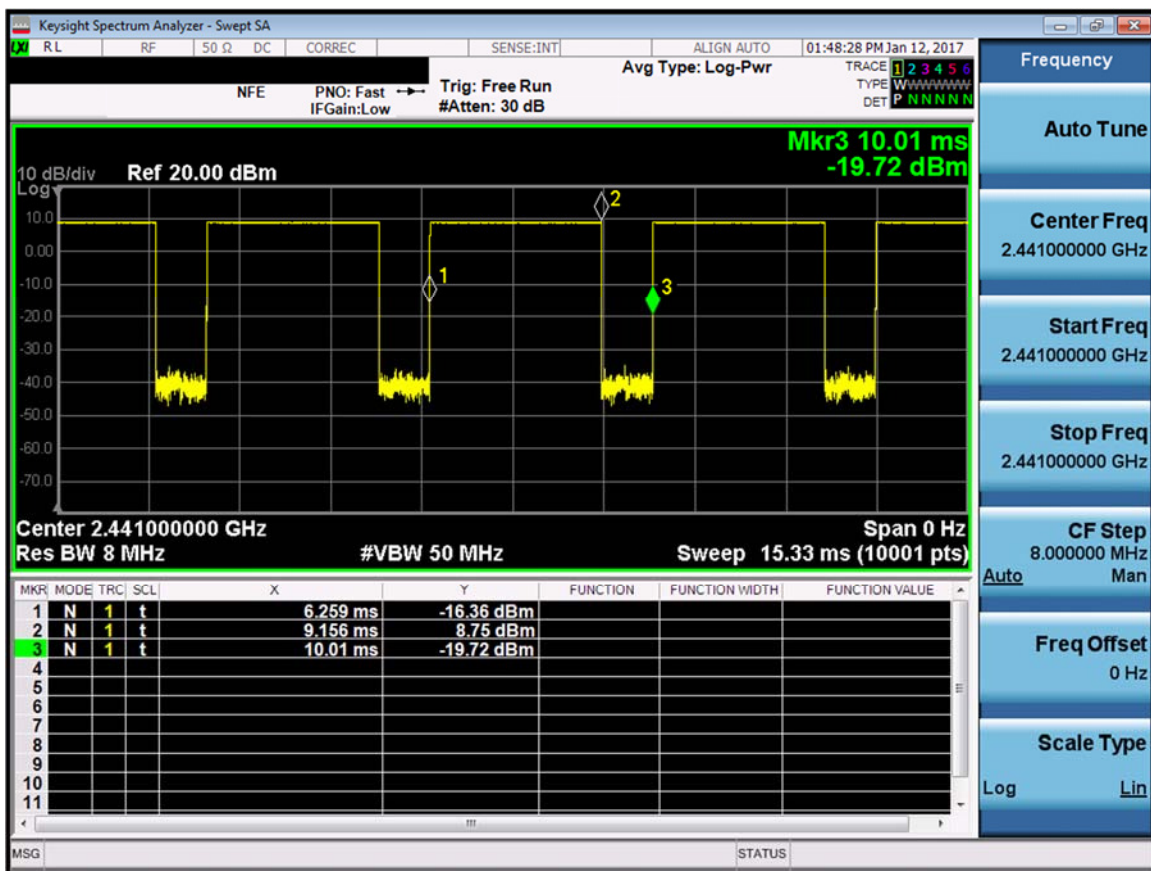



Figure 9-6
Bluetooth Transmission Plot

Equation 9-1
Bluetooth Duty Cycle Calculation

$$Duty\ Cycle = \frac{Pulse\ Width}{Period} * 100\% = \frac{(9.156 - 6.259)\ ms}{(10.01 - 6.259)\ ms} * 100\% = 77.2\%$$

FCC ID: ZNFH871		SAR EVALUATION REPORT		Approved by: Quality Manager
Document S/N: 1M1701180032-01-R4.ZNF	Test Dates: 01/20/17 - 01/30/17	DUT Type: Portable Handset		Page 50 of 97



10 SYSTEM VERIFICATION

10.1 Tissue Verification

**Table 10-1
Measured Tissue Properties**

Calibrated for Tests Performed on:	Tissue Type	Tissue Temp During Calibration (°C)	Measured Frequency (MHz)	Measured Conductivity, σ (S/m)	Measured Dielectric Constant, ϵ	TARGET Conductivity, σ (S/m)	TARGET Dielectric Constant, ϵ	% dev σ	% dev ϵ
1/25/2017	750H	22.2	700	0.859	42.900	0.889	42.201	-3.37%	1.66%
			710	0.869	42.739	0.890	42.149	-2.36%	1.40%
			740	0.897	42.315	0.893	41.994	0.45%	0.76%
			755	0.910	42.124	0.894	41.916	1.79%	0.50%
			770	0.924	41.938	0.895	41.838	3.24%	0.24%
			785	0.938	41.734	0.896	41.760	4.69%	-0.06%
1/30/2017	835H	22.6	820	0.878	40.696	0.899	41.578	-2.34%	-2.12%
			835	0.888	40.454	0.900	41.500	-1.33%	-2.52%
			850	0.907	40.351	0.916	41.500	-0.98%	-2.77%
1/27/2017	1750H	22.0	1710	1.325	39.024	1.348	40.142	-1.71%	-2.79%
			1750	1.360	38.821	1.371	40.079	-0.80%	-3.14%
			1790	1.398	38.651	1.394	40.016	0.29%	-3.41%
1/24/2017	1900H	22.5	1850	1.405	40.326	1.400	40.000	0.36%	0.82%
			1880	1.437	40.181	1.400	40.000	2.64%	0.45%
			1910	1.467	40.046	1.400	40.000	4.79%	0.11%
1/30/2017	1900H	21.3	1850	1.395	38.408	1.400	40.000	-0.36%	-3.98%
			1880	1.430	38.258	1.400	40.000	2.14%	-4.35%
			1910	1.464	38.120	1.400	40.000	4.57%	-4.70%
1/22/2017	2300H	24.0	2300	1.695	38.794	1.670	39.500	1.50%	-1.79%
			2310	1.708	38.758	1.679	39.480	1.73%	-1.83%
			2320	1.719	38.721	1.687	39.460	1.90%	-1.87%
1/20/2017	2450H	24.5	2400	1.828	39.570	1.756	39.289	4.10%	0.72%
			2450	1.878	39.433	1.800	39.200	4.33%	0.59%
			2500	1.935	39.193	1.855	39.136	4.31%	0.15%
1/22/2017	2600H	24.0	2500	1.931	37.926	1.855	39.136	4.10%	-3.09%
			2550	1.984	37.744	1.909	39.073	3.93%	-3.40%
			2600	2.042	37.518	1.964	39.009	3.97%	-3.82%
			5240	4.554	34.993	4.696	35.940	-3.02%	-2.63%
			5260	4.590	34.983	4.717	35.917	-2.69%	-2.60%
			5300	4.613	34.928	4.758	35.871	-3.05%	-2.63%
01/23/2017	5250H-5750H	20.3	5580	4.883	34.540	5.045	35.551	-3.21%	-2.84%
			5600	4.914	34.502	5.065	35.529	-2.98%	-2.89%
			5745	5.070	34.326	5.214	35.363	-2.76%	-2.93%
			5765	5.085	34.297	5.234	35.340	-2.85%	-2.95%
			5785	5.101	34.275	5.255	35.317	-2.93%	-2.95%
			700	0.913	55.104	0.959	55.726	-4.80%	-1.12%
1/30/2017	750B	20.8	710	0.923	54.953	0.960	55.687	-3.85%	-1.32%
			740	0.952	54.559	0.963	55.570	-1.14%	-1.82%
			755	0.966	54.398	0.964	55.512	0.21%	-2.01%
			770	0.981	54.248	0.965	55.453	1.66%	-2.17%
			785	0.996	54.069	0.966	55.395	3.11%	-2.39%
			820	0.986	55.671	0.969	55.258	1.75%	0.75%
1/30/2017	835B	21.1	835	0.999	55.523	0.970	55.200	2.99%	0.59%
			850	1.019	55.358	0.988	55.154	3.14%	0.37%
			1710	1.464	51.733	1.463	53.537	0.07%	-3.37%
1/23/2017	1750B	22.0	1750	1.506	51.573	1.488	53.432	1.21%	-3.48%
			1790	1.550	51.401	1.514	53.326	2.38%	-3.61%
			1710	1.444	52.390	1.463	53.537	-1.30%	-2.14%
1/27/2017	1750B	21.4	1750	1.498	52.205	1.488	53.432	0.00%	-2.30%
			1790	1.533	52.023	1.514	53.326	1.25%	-2.44%
			1850	1.480	52.091	1.520	53.300	-2.63%	-2.27%
1/23/2017	1900B	23.0	1880	1.512	51.983	1.520	53.300	-0.53%	-2.47%
			1910	1.544	51.897	1.520	53.300	1.58%	-2.63%
			1850	1.504	52.304	1.520	53.300	-1.05%	-1.87%
1/25/2017	1900B	22.9	1880	1.536	52.210	1.520	53.300	1.05%	-2.05%
			1910	1.570	52.121	1.520	53.300	3.29%	-2.21%
			1850	1.520	51.375	1.520	53.300	0.00%	-3.61%
1/30/2017	1900B	22.5	1880	1.554	51.266	1.520	53.300	2.24%	-3.82%
			1910	1.588	51.165	1.520	53.300	4.47%	-4.01%
			2300	1.833	52.814	1.809	52.900	1.33%	-0.16%
1/30/2017	2300B	22.6	2310	1.846	52.806	1.816	52.887	1.65%	-0.15%
			2320	1.862	52.761	1.825	52.873	1.97%	-0.21%
			2400	1.908	51.547	1.902	52.767	0.32%	-2.31%
1/24/2017	2450B	23.0	2450	1.973	51.355	1.950	52.700	1.18%	-2.55%
			2500	2.043	51.151	2.021	52.636	1.09%	-2.82%
			2500	2.104	52.057	2.021	52.636	4.11%	-1.10%
1/30/2017	2600B	22.6	2550	2.174	51.907	2.092	52.573	3.92%	-1.27%
			2600	2.250	51.689	2.163	52.509	4.02%	-1.56%
			5200	5.420	47.976	5.299	49.014	2.28%	-2.12%
01/22/2017	5250B-5750B	21.9	5240	5.489	47.916	5.346	48.960	2.67%	-2.13%
			5260	5.515	47.894	5.369	48.933	2.72%	-2.12%
			5280	5.551	47.844	5.393	48.906	2.93%	-2.17%
			5300	5.575	47.792	5.416	48.879	2.94%	-2.22%
			5580	5.949	47.365	5.743	48.499	3.59%	-2.34%
			5600	5.972	47.325	5.766	48.471	3.57%	-2.36%
			5650	6.058	47.190	5.837	48.390	3.79%	-2.48%
			5745	6.172	47.057	5.936	48.275	3.98%	-2.52%
			5765	6.196	47.001	5.959	48.248	3.98%	-2.58%

The above measured tissue parameters were used in the DASY software. The DASY software was used to perform interpolation to determine the dielectric parameters at the SAR test device frequencies (per KDB Publication 865664 D01v01r04 and IEEE 1528-2013 6.6.1.2). The tissue parameters listed in the SAR test plots may slightly differ from the table above due to significant digit rounding in the software.

FCC ID: ZNFH871		SAR EVALUATION REPORT			Approved by: Quality Manager
Document S/N: 1M1701180032-01-R4.ZNF	Test Dates: 01/20/17 - 01/30/17	DUT Type: Portable Handset			Page 51 of 97

10.2 Test System Verification

Prior to SAR assessment, the system is verified to $\pm 10\%$ of the SAR measurement on the reference dipole at the time of calibration by the calibration facility. Full system validation status and result summary can be found in Appendix E.

**Table 10-2
System Verification Results**

System Verification TARGET & MEASURED												
SAR System #	Tissue Frequency (MHz)	Tissue Type	Date:	Amb. Temp (°C)	Liquid Temp (°C)	Input Power (W)	Dipole SN	Probe SN	Measured SAR _{1g} (W/kg)	1 W Target SAR _{1g} (W/kg)	1 W Normalized SAR _{1g} (W/kg)	Deviation _{1g} (%)
I	750	HEAD	01/25/2017	22.3	22.2	0.200	1161	3209	1.570	8.170	7.850	-3.92%
G	835	HEAD	01/30/2017	23.0	21.3	0.200	4d047	3287	1.900	9.130	9.500	4.05%
I	1750	HEAD	01/27/2017	24.0	23.0	0.100	1148	3209	3.370	36.200	33.700	-6.91%
F	1900	HEAD	01/24/2017	22.7	22.5	0.100	5d149	3332	3.900	40.100	39.000	-2.74%
F	1900	HEAD	01/30/2017	22.5	21.5	0.100	5d149	3332	3.890	40.100	38.900	-2.99%
G	2300	HEAD	01/22/2017	23.2	22.5	0.100	1064	3287	4.960	48.400	49.600	2.48%
G	2450	HEAD	01/20/2017	24.1	23.1	0.100	797	3287	5.500	52.100	55.000	5.57%
G	2600	HEAD	01/22/2017	23.2	22.5	0.100	1071	3287	5.610	56.300	56.100	-0.36%
J	5250	HEAD	01/23/2017	20.9	20.3	0.050	1191	7357	3.880	78.900	77.600	-1.65%
J	5600	HEAD	01/23/2017	20.9	20.3	0.050	1191	7357	4.120	83.600	82.400	-1.44%
J	5750	HEAD	01/23/2017	20.9	20.3	0.050	1191	7357	3.910	79.100	78.200	-1.14%
I	750	BODY	01/30/2017	22.7	20.8	0.200	1161	3209	1.760	8.430	8.800	4.39%
H	835	BODY	01/30/2017	22.8	21.1	0.200	4d047	3319	1.950	9.570	9.750	1.88%
I	1750	BODY	01/23/2017	23.6	23.0	0.100	1148	3209	3.930	37.100	39.300	5.93%
D	1750	BODY	01/27/2017	23.2	21.6	0.100	1148	3213	3.570	37.100	35.700	-3.77%
K	1900	BODY	01/23/2017	23.9	23.4	0.100	5d149	7409	3.930	39.900	39.300	-1.50%
K	1900	BODY	01/25/2017	24.0	21.5	0.100	5d080	7409	3.980	39.100	39.800	1.79%
J	1900	BODY	01/30/2017	20.9	21.5	0.100	5d080	7357	4.180	39.100	41.800	6.91%
E	2300	BODY	01/30/2017	22.5	21.5	0.100	1064	7406	4.640	47.000	46.400	-1.28%
E	2450	BODY	01/24/2017	24.0	23.0	0.100	981	7406	4.940	50.800	49.400	-2.76%
E	2600	BODY	01/30/2017	22.5	21.5	0.100	1071	7406	5.790	54.200	57.900	6.83%
D	5250	BODY	01/22/2017	21.9	21.4	0.050	1237	3914	3.490	74.800	69.800	-6.68%
D	5600	BODY	01/22/2017	21.9	21.4	0.050	1237	3914	3.950	77.000	79.000	2.60%
D	5750	BODY	01/22/2017	21.9	21.4	0.050	1237	3914	3.430	75.400	68.600	-9.02%

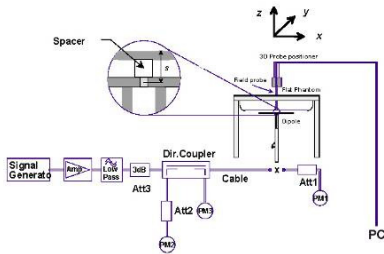

**Figure 10-1
System Verification Setup Diagram**



**Figure 10-2
System Verification Setup Photo**

FCC ID: ZNFH871	PCTEST ENGINEERING LABORATORY, INC.	SAR EVALUATION REPORT	LG	Approved by: Quality Manager
Document S/N: 1M1701180032-01-R4.ZNF	Test Dates: 01/20/17 - 01/30/17	DUT Type: Portable Handset		Page 52 of 97

11 SAR DATA SUMMARY



11.1 Standalone Head SAR Data

**Table 11-1
GSM 850 Head SAR**

MEASUREMENT RESULTS															
FREQUENCY		Mode/Band	Service	Maximum Allowed Power [dBm]	Conducted Power [dBm]	Power Drift [dB]	Side	Test Position	Device Serial Number	# of Time Slots	Duty Cycle	SAR (1g)	Scaling Factor	Reported SAR (1g)	Plot #
MHz	Ch.											(W/kg)		(W/kg)	
836.60	190	GSM 850	GSM	33.2	33.20	0.15	Right	Cheek	08465	1	1:8.3	0.135	1.000	0.135	
836.60	190	GSM 850	GSM	33.2	33.20	0.06	Right	Tilt	08465	1	1:8.3	0.091	1.000	0.091	
836.60	190	GSM 850	GSM	33.2	33.20	0.07	Left	Cheek	08465	1	1:8.3	0.191	1.000	0.191	
836.60	190	GSM 850	GSM	33.2	33.20	0.02	Left	Tilt	08465	1	1:8.3	0.086	1.000	0.086	
836.60	190	GSM 850	GPRS	30.2	30.20	0.04	Right	Cheek	08465	3	1:2.76	0.272	1.000	0.272	
836.60	190	GSM 850	GPRS	30.2	30.20	-0.09	Right	Tilt	08465	3	1:2.76	0.166	1.000	0.166	
836.60	190	GSM 850	GPRS	30.2	30.20	-0.11	Left	Cheek	08465	3	1:2.76	0.376	1.000	0.376	A1
836.60	190	GSM 850	GPRS	30.2	30.20	-0.14	Left	Tilt	08465	3	1:2.76	0.155	1.000	0.155	
ANSI / IEEE C95.1 1992 - SAFETY LIMIT Spatial Peak Uncontrolled Exposure/General Population							Head 1.6 W/kg (mW/g) averaged over 1 gram								

**Table 11-2
UMTS 850 Head SAR**

MEASUREMENT RESULTS														
FREQUENCY		Mode/Band	Service	Maximum Allowed Power [dBm]	Conducted Power [dBm]	Power Drift [dB]	Side	Test Position	Device Serial Number	Duty Cycle	SAR (1g)	Scaling Factor	Reported SAR (1g)	Plot #
MHz	Ch.										(W/kg)		(W/kg)	
836.60	4183	UMTS 850	RMC	24.7	24.65	-0.07	Right	Cheek	08465	1:1	0.044	1.012	0.045	
836.60	4183	UMTS 850	RMC	24.7	24.65	0.18	Right	Tilt	08465	1:1	0.029	1.012	0.029	
836.60	4183	UMTS 850	RMC	24.7	24.65	-0.05	Left	Cheek	08465	1:1	0.062	1.012	0.063	A2
836.60	4183	UMTS 850	RMC	24.7	24.65	0.16	Left	Tilt	08465	1:1	0.028	1.012	0.028	
ANSI / IEEE C95.1 1992 - SAFETY LIMIT Spatial Peak Uncontrolled Exposure/General Population							Head 1.6 W/kg (mW/g) averaged over 1 gram							

FCC ID: ZNFH871	 PCTEST ENGINEERING LABORATORY, INC.	SAR EVALUATION REPORT	 LG	Approved by: Quality Manager
Document S/N: 1M1701180032-01-R4.ZNF	Test Dates: 01/20/17 - 01/30/17	DUT Type: Portable Handset	Page 53 of 97	

**Table 11-3
UMTS 1750 Head SAR**



MEASUREMENT RESULTS														
FREQUENCY		Mode/Band	Service	Maximum Allowed Power [dBm]	Conducted Power [dBm]	Power Drift [dB]	Side	Test Position	Device Serial Number	Duty Cycle	SAR (1g)	Scaling Factor	Reported SAR (1g)	Plot #
MHz	Ch.										(W/kg)		(W/kg)	
1732.40	1412	UMTS 1750	RMC	25.0	24.98	0.09	Right	Cheek	06440	1:1	0.082	1.005	0.082	
1732.40	1412	UMTS 1750	RMC	25.0	24.98	0.01	Right	Tilt	06440	1:1	0.083	1.005	0.083	
1732.40	1412	UMTS 1750	RMC	25.0	24.98	0.00	Left	Cheek	06440	1:1	0.161	1.005	0.162	A3
1732.40	1412	UMTS 1750	RMC	25.0	24.98	-0.15	Left	Tilt	06440	1:1	0.103	1.005	0.104	
ANSI / IEEE C95.1 1992 - SAFETY LIMIT Spatial Peak Uncontrolled Exposure/General Population							Head 1.6 W/kg (mW/g) averaged over 1 gram							

**Table 11-4
GSM 1900 Head SAR**

MEASUREMENT RESULTS															
FREQUENCY		Mode/Band	Service	Maximum Allowed Power [dBm]	Conducted Power [dBm]	Power Drift [dB]	Side	Test Position	Device Serial Number	# of Time Slots	Duty Cycle	SAR (1g)	Scaling Factor	Reported SAR (1g)	Plot #
MHz	Ch.											(W/kg)		(W/kg)	
1880.00	661	GSM 1900	GSM	30.7	30.67	-0.11	Right	Cheek	08473	1	1:8.3	0.110	1.007	0.111	
1880.00	661	GSM 1900	GSM	30.7	30.67	-0.12	Right	Tilt	08473	1	1:8.3	0.036	1.007	0.036	
1880.00	661	GSM 1900	GSM	30.7	30.67	-0.04	Left	Cheek	08473	1	1:8.3	0.105	1.007	0.106	
1880.00	661	GSM 1900	GSM	30.7	30.67	0.15	Left	Tilt	08473	1	1:8.3	0.051	1.007	0.051	
1880.00	661	GSM 1900	GPRS	27.2	27.20	0.02	Right	Cheek	08473	3	1:2.76	0.122	1.000	0.122	
1880.00	661	GSM 1900	GPRS	27.2	27.20	0.15	Right	Tilt	08473	3	1:2.76	0.042	1.000	0.042	
1880.00	661	GSM 1900	GPRS	27.2	27.20	0.01	Left	Cheek	08473	3	1:2.76	0.146	1.000	0.146	A4
1880.00	661	GSM 1900	GPRS	27.2	27.20	0.15	Left	Tilt	08473	3	1:2.76	0.066	1.000	0.066	
ANSI / IEEE C95.1 1992 - SAFETY LIMIT Spatial Peak Uncontrolled Exposure/General Population							Head 1.6 W/kg (mW/g) averaged over 1 gram								

**Table 11-5
UMTS 1900 Head SAR**

MEASUREMENT RESULTS														
FREQUENCY		Mode/Band	Service	Maximum Allowed Power [dBm]	Conducted Power [dBm]	Power Drift [dB]	Side	Test Position	Device Serial Number	Duty Cycle	SAR (1g)	Scaling Factor	Reported SAR (1g)	Plot #
MHz	Ch.										(W/kg)		(W/kg)	
1880.00	9400	UMTS 1900	RMC	25.0	25.00	0.03	Right	Cheek	08465	1:1	0.188	1.000	0.188	
1880.00	9400	UMTS 1900	RMC	25.0	25.00	0.06	Right	Tilt	08465	1:1	0.081	1.000	0.081	
1880.00	9400	UMTS 1900	RMC	25.0	25.00	0.04	Left	Cheek	08465	1:1	0.225	1.000	0.225	A5
1880.00	9400	UMTS 1900	RMC	25.0	25.00	0.12	Left	Tilt	08465	1:1	0.092	1.000	0.092	
ANSI / IEEE C95.1 1992 - SAFETY LIMIT Spatial Peak Uncontrolled Exposure/General Population							Head 1.6 W/kg (mW/g) averaged over 1 gram							

FCC ID: ZNFH871		SAR EVALUATION REPORT		Approved by: Quality Manager
Document S/N: 1M1701180032-01-R4.ZNF	Test Dates: 01/20/17 - 01/30/17	DUT Type: Portable Handset		Page 54 of 97

**Table 11-6
LTE Band 12 Head SAR**



MEASUREMENT RESULTS																			
FREQUENCY		Mode	Bandwidth [MHz]	Maximum Allowed Power [dBm]	Conducted Power [dBm]	Power Drift [dB]	MPR [dB]	Side	Test Position	Modulation	RB Size	RB Offset	Device Serial Number	Duty Cycle	SAR (1g)	Scaling Factor	Reported SAR (1g)	Plot #	
MHz	Ch.														(W/kg)		(W/kg)		
707.50	23095	Mid	LTE Band 12	10	25.5	25.50	0.03	0	Right	Cheek	QPSK	1	0	08523	1:1	0.145	1.000	0.145	
707.50	23095	Mid	LTE Band 12	10	24.5	24.48	0.02	1	Right	Cheek	QPSK	25	25	08523	1:1	0.137	1.005	0.138	
707.50	23095	Mid	LTE Band 12	10	25.5	25.50	0.03	0	Right	Tilt	QPSK	1	0	08523	1:1	0.111	1.000	0.111	
707.50	23095	Mid	LTE Band 12	10	24.5	24.48	0.07	1	Right	Tilt	QPSK	25	25	08523	1:1	0.103	1.005	0.104	
707.50	23095	Mid	LTE Band 12	10	25.5	25.50	0.01	0	Left	Cheek	QPSK	1	0	08523	1:1	0.186	1.000	0.186	A6
707.50	23095	Mid	LTE Band 12	10	24.5	24.48	0.04	1	Left	Cheek	QPSK	25	25	08523	1:1	0.163	1.005	0.164	
707.50	23095	Mid	LTE Band 12	10	25.5	25.50	0.14	0	Left	Tilt	QPSK	1	0	08523	1:1	0.090	1.000	0.090	
707.50	23095	Mid	LTE Band 12	10	24.5	24.48	0.02	1	Left	Tilt	QPSK	25	25	08523	1:1	0.080	1.005	0.080	
ANSI / IEEE C95.1 1992 - SAFETY LIMIT Spatial Peak Uncontrolled Exposure/General Population										Head 1.6 W/kg (mW/g) averaged over 1 gram									

**Table 11-7
LTE Band 13 Head SAR**

MEASUREMENT RESULTS																			
FREQUENCY		Mode	Bandwidth [MHz]	Maximum Allowed Power [dBm]	Conducted Power [dBm]	Power Drift [dB]	MPR [dB]	Side	Test Position	Modulation	RB Size	RB Offset	Device Serial Number	Duty Cycle	SAR (1g)	Scaling Factor	Reported SAR (1g)	Plot #	
MHz	Ch.														(W/kg)		(W/kg)		
782.00	23230	Mid	LTE Band 13	10	25.5	25.20	0.13	0	Right	Cheek	QPSK	1	0	08523	1:1	0.070	1.072	0.075	
782.00	23230	Mid	LTE Band 13	10	24.5	24.16	0.14	1	Right	Cheek	QPSK	25	12	08523	1:1	0.059	1.081	0.064	
782.00	23230	Mid	LTE Band 13	10	25.5	25.20	0.13	0	Right	Tilt	QPSK	1	0	08523	1:1	0.046	1.072	0.049	
782.00	23230	Mid	LTE Band 13	10	24.5	24.16	0.13	1	Right	Tilt	QPSK	25	12	08523	1:1	0.040	1.081	0.043	
782.00	23230	Mid	LTE Band 13	10	25.5	25.20	-0.03	0	Left	Cheek	QPSK	1	0	08523	1:1	0.116	1.072	0.124	A7
782.00	23230	Mid	LTE Band 13	10	24.5	24.16	0.13	1	Left	Cheek	QPSK	25	12	08523	1:1	0.090	1.081	0.097	
782.00	23230	Mid	LTE Band 13	10	25.5	25.20	0.19	0	Left	Tilt	QPSK	1	0	08523	1:1	0.052	1.072	0.056	
782.00	23230	Mid	LTE Band 13	10	24.5	24.16	0.13	1	Left	Tilt	QPSK	25	12	08523	1:1	0.042	1.081	0.045	
ANSI / IEEE C95.1 1992 - SAFETY LIMIT Spatial Peak Uncontrolled Exposure/General Population										Head 1.6 W/kg (mW/g) averaged over 1 gram									

**Table 11-8
LTE Band 5 (Cell) Head SAR**

MEASUREMENT RESULTS																			
FREQUENCY		Mode	Bandwidth [MHz]	Maximum Allowed Power [dBm]	Conducted Power [dBm]	Power Drift [dB]	MPR [dB]	Side	Test Position	Modulation	RB Size	RB Offset	Device Serial Number	Duty Cycle	SAR (1g)	Scaling Factor	Reported SAR (1g)	Plot #	
MHz	Ch.														(W/kg)		(W/kg)		
836.50	20525	Mid	LTE Band 5 (Cell)	10	25.5	25.50	-0.07	0	Right	Cheek	QPSK	1	0	08516	1:1	0.170	1.000	0.170	
836.50	20525	Mid	LTE Band 5 (Cell)	10	24.5	24.47	0.03	1	Right	Cheek	QPSK	25	12	08516	1:1	0.117	1.007	0.118	
836.50	20525	Mid	LTE Band 5 (Cell)	10	25.5	25.50	0.09	0	Right	Tilt	QPSK	1	0	08516	1:1	0.118	1.000	0.118	
836.50	20525	Mid	LTE Band 5 (Cell)	10	24.5	24.47	0.02	1	Right	Tilt	QPSK	25	12	08516	1:1	0.076	1.007	0.077	
836.50	20525	Mid	LTE Band 5 (Cell)	10	25.5	25.50	0.08	0	Left	Cheek	QPSK	1	0	08516	1:1	0.238	1.000	0.238	A8
836.50	20525	Mid	LTE Band 5 (Cell)	10	24.5	24.47	-0.07	1	Left	Cheek	QPSK	25	12	08516	1:1	0.183	1.007	0.184	
836.50	20525	Mid	LTE Band 5 (Cell)	10	25.5	25.50	0.03	0	Left	Tilt	QPSK	1	0	08516	1:1	0.101	1.000	0.101	
836.50	20525	Mid	LTE Band 5 (Cell)	10	24.5	24.47	0.07	1	Left	Tilt	QPSK	25	12	08516	1:1	0.077	1.007	0.078	
ANSI / IEEE C95.1 1992 - SAFETY LIMIT Spatial Peak Uncontrolled Exposure/General Population										Head 1.6 W/kg (mW/g) averaged over 1 gram									

FCC ID: ZNFH871		SAR EVALUATION REPORT		Approved by: Quality Manager
Document S/N: 1M1701180032-01-R4.ZNF	Test Dates: 01/20/17 - 01/30/17	DUT Type: Portable Handset	Page 55 of 97	

**Table 11-9
LTE Band 66 (AWS) Head SAR**



MEASUREMENT RESULTS																			
FREQUENCY		Mode	Bandwidth [MHz]	Maximum Allowed Power [dBm]	Conducted Power [dBm]	Power Drift [dB]	MPR [dB]	Side	Test Position	Modulation	RB Size	RB Offset	Device Serial Number	Duty Cycle	SAR (1g)	Scaling Factor	Reported SAR (1g)	Plot #	
MHz	Ch.														(W/kg)		(W/kg)		
1720.00	132072	Low	LTE Band 66 (AWS)	20	25.5	25.50	0.05	0	Right	Cheek	QPSK	1	99	08440	1:1	0.169	1.000	0.169	
1745.00	132322	Mid	LTE Band 66 (AWS)	20	24.5	24.50	0.04	1	Right	Cheek	QPSK	50	0	08440	1:1	0.158	1.000	0.158	
1720.00	132072	Low	LTE Band 66 (AWS)	20	25.5	25.50	0.04	0	Right	Tilt	QPSK	1	99	08440	1:1	0.077	1.000	0.077	
1745.00	132322	Mid	LTE Band 66 (AWS)	20	24.5	24.50	0.04	1	Right	Tilt	QPSK	50	0	08440	1:1	0.062	1.000	0.062	
1720.00	132072	Low	LTE Band 66 (AWS)	20	25.5	25.50	0.13	0	Left	Cheek	QPSK	1	99	08440	1:1	0.228	1.000	0.228	A9
1745.00	132322	Mid	LTE Band 66 (AWS)	20	24.5	24.50	0.09	1	Left	Cheek	QPSK	50	0	08440	1:1	0.203	1.000	0.203	
1720.00	132072	Low	LTE Band 66 (AWS)	20	25.5	25.50	0.08	0	Left	Tilt	QPSK	1	99	08440	1:1	0.113	1.000	0.113	
1745.00	132322	Mid	LTE Band 66 (AWS)	20	24.5	24.50	0.07	1	Left	Tilt	QPSK	50	0	08440	1:1	0.098	1.000	0.098	
ANSI / IEEE C95.1 1992 - SAFETY LIMIT Spatial Peak Uncontrolled Exposure/General Population										Head 1.6 W/kg (mW/g) averaged over 1 gram									

**Table 11-10
LTE Band 25 (PCS) Head SAR**

MEASUREMENT RESULTS																			
FREQUENCY		Mode	Bandwidth [MHz]	Maximum Allowed Power [dBm]	Conducted Power [dBm]	Power Drift [dB]	MPR [dB]	Side	Test Position	Modulation	RB Size	RB Offset	Device Serial Number	Duty Cycle	SAR (1g)	Scaling Factor	Reported SAR (1g)	Plot #	
MHz	Ch.														(W/kg)		(W/kg)		
1882.50	26365	Mid	LTE Band 25 (PCS)	20	25.0	25.00	0.13	0	Right	Cheek	QPSK	1	0	08457	1:1	0.204	1.000	0.204	
1882.50	26365	Mid	LTE Band 25 (PCS)	20	24.0	24.00	0.01	1	Right	Cheek	QPSK	50	0	08457	1:1	0.144	1.000	0.144	
1882.50	26365	Mid	LTE Band 25 (PCS)	20	25.0	25.00	-0.08	0	Right	Tilt	QPSK	1	0	08457	1:1	0.071	1.000	0.071	
1882.50	26365	Mid	LTE Band 25 (PCS)	20	24.0	24.00	-0.02	1	Right	Tilt	QPSK	50	0	08457	1:1	0.056	1.000	0.056	
1882.50	26365	Mid	LTE Band 25 (PCS)	20	25.0	25.00	-0.01	0	Left	Cheek	QPSK	1	0	08457	1:1	0.209	1.000	0.209	A10
1882.50	26365	Mid	LTE Band 25 (PCS)	20	24.0	24.00	0.00	1	Left	Cheek	QPSK	50	0	08457	1:1	0.155	1.000	0.155	
1882.50	26365	Mid	LTE Band 25 (PCS)	20	25.0	25.00	-0.01	0	Left	Tilt	QPSK	1	0	08457	1:1	0.101	1.000	0.101	
1882.50	26365	Mid	LTE Band 25 (PCS)	20	24.0	24.00	-0.01	1	Left	Tilt	QPSK	50	0	08457	1:1	0.073	1.000	0.073	
ANSI / IEEE C95.1 1992 - SAFETY LIMIT Spatial Peak Uncontrolled Exposure/General Population										Head 1.6 W/kg (mW/g) averaged over 1 gram									

**Table 11-11
LTE Band 30 Head SAR**

MEASUREMENT RESULTS																			
FREQUENCY		Mode	Bandwidth [MHz]	Maximum Allowed Power [dBm]	Conducted Power [dBm]	Power Drift [dB]	MPR [dB]	Side	Test Position	Modulation	RB Size	RB Offset	Device Serial Number	Duty Cycle	SAR (1g)	Scaling Factor	Reported SAR (1g)	Plot #	
MHz	Ch.														(W/kg)		(W/kg)		
2310.00	27710	Mid	LTE Band 30	10	25.5	25.48	0.13	0	Right	Cheek	QPSK	1	0	08515	1:1	0.094	1.005	0.094	A11
2310.00	27710	Mid	LTE Band 30	10	24.5	24.48	0.15	1	Right	Cheek	QPSK	25	12	08515	1:1	0.072	1.005	0.072	
2310.00	27710	Mid	LTE Band 30	10	25.5	25.48	0.12	0	Right	Tilt	QPSK	1	0	08515	1:1	0.058	1.005	0.058	
2310.00	27710	Mid	LTE Band 30	10	24.5	24.48	0.13	1	Right	Tilt	QPSK	25	12	08515	1:1	0.041	1.005	0.041	
2310.00	27710	Mid	LTE Band 30	10	25.5	25.48	0.19	0	Left	Cheek	QPSK	1	0	08515	1:1	0.083	1.005	0.083	
2310.00	27710	Mid	LTE Band 30	10	24.5	24.48	0.16	1	Left	Cheek	QPSK	25	12	08515	1:1	0.067	1.005	0.067	
2310.00	27710	Mid	LTE Band 30	10	25.5	25.48	0.04	0	Left	Tilt	QPSK	1	0	08515	1:1	0.044	1.005	0.044	
2310.00	27710	Mid	LTE Band 30	10	24.5	24.48	0.05	1	Left	Tilt	QPSK	25	12	08515	1:1	0.033	1.005	0.033	
ANSI / IEEE C95.1 1992 - SAFETY LIMIT Spatial Peak Uncontrolled Exposure/General Population										Head 1.6 W/kg (mW/g) averaged over 1 gram									



FCC ID: ZNFH871		SAR EVALUATION REPORT		Approved by: Quality Manager
Document S/N: 1M1701180032-01-R4.ZNF	Test Dates: 01/20/17 - 01/30/17	DUT Type: Portable Handset		Page 56 of 97

**Table 11-12
LTE Band 7 Head SAR**

MEASUREMENT RESULTS																			
FREQUENCY		Mode	Bandwidth [MHz]	Maximum Allowed Power [dBm]	Conducted Power [dBm]	Power Drift [dB]	MPR [dB]	Side	Test Position	Modulation	RB Size	RB Offset	Device Serial Number	Duty Cycle	SAR (1g)	Scaling Factor	Reported SAR (1g)	Plot #	
MHz	Ch.														(W/kg)		(W/kg)		
2560.00	21350	High	LTE Band 7	20	25.5	25.50	0.09	0	Right	Cheek	QPSK	1	0	08523	1:1	0.066	1.000	0.066	
2535.00	21100	Mid	LTE Band 7	20	24.5	24.49	0.13	1	Right	Cheek	QPSK	50	25	08523	1:1	0.043	1.002	0.043	
2560.00	21350	High	LTE Band 7	20	25.5	25.50	0.19	0	Right	Tilt	QPSK	1	0	08523	1:1	0.045	1.000	0.045	
2535.00	21100	Mid	LTE Band 7	20	24.5	24.49	0.14	1	Right	Tilt	QPSK	50	25	08523	1:1	0.030	1.002	0.030	
2560.00	21350	High	LTE Band 7	20	25.5	25.50	0.12	0	Left	Cheek	QPSK	1	0	08523	1:1	0.079	1.000	0.079	A12
2535.00	21100	Mid	LTE Band 7	20	24.5	24.49	0.12	1	Left	Cheek	QPSK	50	25	08523	1:1	0.053	1.002	0.053	
2560.00	21350	High	LTE Band 7	20	25.5	25.50	0.15	0	Left	Tilt	QPSK	1	0	08523	1:1	0.022	1.000	0.022	
2535.00	21100	Mid	LTE Band 7	20	24.5	24.49	0.13	1	Left	Tilt	QPSK	50	25	08523	1:1	0.013	1.002	0.013	
ANSI / IEEE C95.1 1992 - SAFETY LIMIT Spatial Peak Uncontrolled Exposure/General Population										Head 1.6 W/kg (mW/g) averaged over 1 gram									



**Table 11-13
DTS Head SAR**

MEASUREMENT RESULTS																			
FREQUENCY		Mode	Service	Bandwidth [MHz]	Maximum Allowed Power [dBm]	Conducted Power [dBm]	Power Drift [dB]	Side	Test Position	Antenna Config.	Device Serial Number	Data Rate (Mbps)	Duty Cycle (%)	Peak SAR of Area Scan	SAR (1g)	Scaling Factor (Power)	Scaling Factor (Duty Cycle)	Reported SAR (1g)	Plot #
MHz	Ch.													W/kg	(W/kg)			(W/kg)	
2437	6	802.11b	DSSS	22	15.5	15.46	-0.10	Right	Cheek	Primary	08564	1	99.9	0.856	0.611	1.009	1.001	0.617	
2437	6	802.11b	DSSS	22	15.5	15.46	0.12	Right	Tilt	Primary	08564	1	99.9	0.188	0.163	1.009	1.001	0.165	
2437	6	802.11b	DSSS	22	15.5	15.46	0.12	Left	Cheek	Primary	08564	1	99.9	0.155	0.132	1.009	1.001	0.133	
2437	6	802.11b	DSSS	22	15.5	15.46	0.11	Left	Tilt	Primary	08564	1	99.9	0.061	-	1.009	1.001	-	
2437	6	802.11b	DSSS	22	15.5	15.31	-0.14	Right	Cheek	Secondary	08564	1	99.9	0.838	0.666	1.045	1.001	0.697	A13
2437	6	802.11b	DSSS	22	15.5	15.31	-0.02	Right	Tilt	Secondary	08564	1	99.9	0.763	0.567	1.045	1.001	0.593	
2437	6	802.11b	DSSS	22	15.5	15.31	-0.06	Left	Cheek	Secondary	08564	1	99.9	0.665	0.517	1.045	1.001	0.541	
2437	6	802.11b	DSSS	22	15.5	15.31	-0.07	Left	Tilt	Secondary	08564	1	99.9	0.497	-	1.045	1.001	-	
ANSI / IEEE C95.1 1992 - SAFETY LIMIT Spatial Peak Uncontrolled Exposure/General Population										Head 1.6 W/kg (mW/g) averaged over 1 gram									

FCC ID: ZNFH871		SAR EVALUATION REPORT		Approved by: Quality Manager
Document S/N: 1M1701180032-01-R4.ZNF	Test Dates: 01/20/17 - 01/30/17	DUT Type: Portable Handset	Page 57 of 97	

**Table 11-14
NII Head SAR**



MEASUREMENT RESULTS																			
FREQUENCY		Mode	Service	Bandwidth [MHz]	Maximum Allowed Power [dBm]	Conducted Power [dBm]	Power Drift [dB]	Side	Test Position	Antenna Config.	Device Serial Number	Data Rate (Mbps)	Duty Cycle (%)	Peak SAR of Area Scan	SAR (1g)	Scaling Factor (Power)	Scaling Factor (Duty Cycle)	Reported SAR (1g) (W/kg)	Plot #
MHz	Ch.													W/kg	(W/kg)				
5300	60	802.11a	OFDM	20	14.5	14.14	-0.16	Right	Cheek	Primary	08564	6	99.3	0.107	0.054	1.086	1.007	0.059	
5300	60	802.11a	OFDM	20	14.5	14.14	0.19	Right	Tilt	Primary	08564	6	99.3	0.051	-	1.086	1.007	-	
5300	60	802.11a	OFDM	20	14.5	14.14	0.10	Left	Cheek	Primary	08564	6	99.3	0.048	-	1.086	1.007	-	
5300	60	802.11a	OFDM	20	14.5	14.14	0.11	Left	Tilt	Primary	08564	6	99.3	0.037	-	1.086	1.007	-	
5260	52	802.11a	OFDM	20	14.5	14.41	0.10	Right	Cheek	Secondary	08564	6	99.3	1.329	0.634	1.021	1.007	0.652	A14
5260	52	802.11a	OFDM	20	14.5	14.41	0.10	Right	Tilt	Secondary	08564	6	99.3	1.216	0.574	1.021	1.007	0.590	
5260	52	802.11a	OFDM	20	14.5	14.41	0.11	Left	Cheek	Secondary	08564	6	99.3	0.553	-	1.021	1.007	-	
5260	52	802.11a	OFDM	20	14.5	14.41	0.10	Left	Tilt	Secondary	08564	6	99.3	0.483	-	1.021	1.007	-	
5580	116	802.11a	OFDM	20	14.5	14.21	-0.13	Right	Cheek	Primary	08564	6	99.3	0.120	0.042	1.069	1.007	0.045	
5580	116	802.11a	OFDM	20	14.5	14.21	-0.15	Right	Tilt	Primary	08564	6	99.3	0.063	-	1.069	1.007	-	
5580	116	802.11a	OFDM	20	14.5	14.21	0.12	Left	Cheek	Primary	08564	6	99.3	0.055	-	1.069	1.007	-	
5580	116	802.11a	OFDM	20	14.5	14.21	0.19	Left	Tilt	Primary	08564	6	99.3	0.038	-	1.069	1.007	-	
5580	116	802.11a	OFDM	20	14.5	14.46	0.17	Right	Cheek	Secondary	08564	6	99.3	0.441	0.309	1.009	1.007	0.314	
5580	116	802.11a	OFDM	20	14.5	14.46	0.12	Right	Tilt	Secondary	08564	6	99.3	0.272	-	1.009	1.007	-	
5580	116	802.11a	OFDM	20	14.5	14.46	0.10	Left	Cheek	Secondary	08564	6	99.3	0.228	-	1.009	1.007	-	
5580	116	802.11a	OFDM	20	14.5	14.46	0.10	Left	Tilt	Secondary	08564	6	99.3	0.170	-	1.009	1.007	-	
5785	157	802.11a	OFDM	20	14.5	14.14	0.10	Right	Cheek	Primary	08564	6	99.3	0.308	0.112	1.086	1.007	0.122	
5785	157	802.11a	OFDM	20	14.5	14.14	0.10	Right	Tilt	Primary	08564	6	99.3	0.101	-	1.086	1.007	-	
5785	157	802.11a	OFDM	20	14.5	14.14	0.11	Left	Cheek	Primary	08564	6	99.3	0.071	-	1.086	1.007	-	
5785	157	802.11a	OFDM	20	14.5	14.14	0.10	Left	Tilt	Primary	08564	6	99.3	0.053	-	1.086	1.007	-	
5785	157	802.11a	OFDM	20	14.5	14.46	0.10	Right	Cheek	Secondary	08564	6	99.3	0.071	0.003	1.009	1.007	0.003	
5785	157	802.11a	OFDM	20	14.5	14.46	0.10	Right	Tilt	Secondary	08564	6	99.3	0.065	-	1.009	1.007	-	
5785	157	802.11a	OFDM	20	14.5	14.46	0.10	Left	Cheek	Secondary	08564	6	99.3	0.045	-	1.009	1.007	-	
5785	157	802.11a	OFDM	20	14.5	14.46	0.15	Left	Tilt	Secondary	08564	6	99.3	0.041	-	1.009	1.007	-	
ANSI / IEEE C95.1 1992 - SAFETY LIMIT Spatial Peak Uncontrolled Exposure/General Population											Head 1.6 W/kg (mW/g) averaged over 1 gram								

FCC ID: ZNFH871		SAR EVALUATION REPORT		Approved by: Quality Manager
Document S/N: 1M1701180032-01-R4.ZNF	Test Dates: 01/20/17 - 01/30/17	DUT Type: Portable Handset		Page 58 of 97

11.2 Standalone Body-Worn SAR Data

**Table 11-15
GSM/UMTS Body-Worn SAR Data**

MEASUREMENT RESULTS															
FREQUENCY		Mode	Service	Maximum Allowed Power [dBm]	Conducted Power [dBm]	Power Drift [dB]	Spacing	Device Serial Number	# of Time Slots	Duty Cycle	Side	SAR (1g)	Scaling Factor	Reported SAR (1g)	Plot #
MHz	Ch.											(W/kg)		(W/kg)	
836.60	190	GSM 850	GSM	33.2	33.20	-0.03	10 mm	08465	1	1:8.3	back	0.534	1.000	0.534	
824.20	128	GSM 850	GPRS	30.2	30.14	0.00	10 mm	08465	3	1:2.76	back	0.815	1.014	0.826	
836.60	190	GSM 850	GPRS	30.2	30.20	-0.01	10 mm	08465	3	1:2.76	back	0.948	1.000	0.948	
848.80	251	GSM 850	GPRS	30.2	30.20	0.00	10 mm	08465	3	1:2.76	back	0.989	1.000	0.989	A15
836.60	4183	UMTS 850	RMC	24.7	24.65	-0.02	10 mm	08465	N/A	1:1	back	0.254	1.012	0.257	A17
1712.40	1312	UMTS 1750	RMC	25.0	24.96	-0.07	10 mm	08473	N/A	1:1	back	0.728	1.009	0.735	
1732.40	1412	UMTS 1750	RMC	25.0	24.98	0.01	10 mm	08473	N/A	1:1	back	0.882	1.005	0.886	
1752.60	1513	UMTS 1750	RMC	25.0	24.90	0.05	10 mm	08473	N/A	1:1	back	0.936	1.023	0.958	A18
1880.00	661	GSM 1900	GSM	30.7	30.67	-0.04	10 mm	08465	1	1:8.3	back	0.276	1.007	0.278	
1880.00	661	GSM 1900	GPRS	27.2	27.20	0.00	10 mm	08465	3	1:2.76	back	0.316	1.000	0.316	A19
1880.00	9400	UMTS 1900	RMC	25.0	25.00	-0.10	10 mm	08465	N/A	1:1	back	0.789	1.000	0.789	A21
ANSI / IEEE C95.1 1992 - SAFETY LIMIT Spatial Peak Uncontrolled Exposure/General Population							Body 1.6 W/kg (mW/g) averaged over 1 gram								

FCC ID: ZNFH871		SAR EVALUATION REPORT		Approved by: Quality Manager
Document S/N: 1M1701180032-01-R4.ZNF	Test Dates: 01/20/17 - 01/30/17	DUT Type: Portable Handset		Page 59 of 97



**Table 11-16
LTE Body-Worn SAR**

MEASUREMENT RESULTS																			
FREQUENCY		Mode	Bandwidth [MHz]	Maximum Allowed Power [dBm]	Conducted Power [dBm]	Power Drift [dB]	MPR [dB]	Device Serial Number	Modulation	RB Size	RB Offset	Spacing	Side	Duty Cycle	SAR (1g) (W/kg)	Scaling Factor	Reported SAR (1g) (W/kg)	Plot #	
MHz	Ch.																		
707.50	23095	Mid	LTE Band 12	10	25.5	25.50	0.01	0	08440	QPSK	1	0	10 mm	back	1:1	0.688	1.000	0.688	A22
707.50	23095	Mid	LTE Band 12	10	24.5	24.48	-0.02	1	08440	QPSK	25	25	10 mm	back	1:1	0.562	1.005	0.565	
782.00	23230	Mid	LTE Band 13	10	25.5	25.20	0.07	0	08440	QPSK	1	0	10 mm	back	1:1	0.442	1.072	0.474	A24
782.00	23230	Mid	LTE Band 13	10	24.5	24.16	-0.01	1	08440	QPSK	25	12	10 mm	back	1:1	0.320	1.081	0.346	
836.50	20525	Mid	LTE Band 5 (Cell)	10	25.5	25.50	-0.10	0	08440	QPSK	1	0	10 mm	back	1:1	0.495	1.000	0.495	A25
836.50	20525	Mid	LTE Band 5 (Cell)	10	24.5	24.47	0.05	1	08440	QPSK	25	12	10 mm	back	1:1	0.406	1.007	0.409	
1720.00	132072	Low	LTE Band 66 (AWS)	20	25.5	25.50	0.00	0	08440	QPSK	1	99	10 mm	back	1:1	1.060	1.000	1.060	
1745.00	132322	Mid	LTE Band 66 (AWS)	20	25.5	25.46	-0.02	0	08440	QPSK	1	50	10 mm	back	1:1	1.100	1.009	1.110	A27
1770.00	132572	High	LTE Band 66 (AWS)	20	25.5	25.49	0.02	0	08440	QPSK	1	50	10 mm	back	1:1	0.994	1.002	0.996	
1720.00	132072	Low	LTE Band 66 (AWS)	20	24.5	24.45	0.03	1	08440	QPSK	50	0	10 mm	back	1:1	0.906	1.012	0.917	
1745.00	132322	Mid	LTE Band 66 (AWS)	20	24.5	24.50	0.02	1	08440	QPSK	50	0	10 mm	back	1:1	0.946	1.000	0.946	
1770.00	132572	High	LTE Band 66 (AWS)	20	24.5	24.48	-0.01	1	08440	QPSK	50	0	10 mm	back	1:1	0.853	1.005	0.857	
1770.00	132572	High	LTE Band 66 (AWS)	20	24.5	24.48	-0.01	1	08440	QPSK	100	0	10 mm	back	1:1	0.863	1.005	0.867	
1745.00	132322	Mid	LTE Band 66 (AWS)	20	25.5	25.46	0.00	0	08440	QPSK	1	50	10 mm	back	1:1	1.030	1.009	1.039	
1860.00	26140	Low	LTE Band 25 (PCS)	20	25.0	24.98	0.02	0	08457	QPSK	1	50	10 mm	back	1:1	0.974	1.005	0.979	A28
1882.50	26365	Mid	LTE Band 25 (PCS)	20	25.0	25.00	-0.05	0	08457	QPSK	1	0	10 mm	back	1:1	0.898	1.000	0.898	
1905.00	26590	High	LTE Band 25 (PCS)	20	25.0	24.97	-0.01	0	08457	QPSK	1	50	10 mm	back	1:1	0.729	1.007	0.734	
1882.50	26365	Mid	LTE Band 25 (PCS)	20	24.0	24.00	-0.10	1	08457	QPSK	50	0	10 mm	back	1:1	0.677	1.000	0.677	
1905.00	26590	High	LTE Band 25 (PCS)	20	24.0	23.99	-0.08	1	08457	QPSK	100	0	10 mm	back	1:1	0.652	1.002	0.653	
2310.00	27710	Mid	LTE Band 30	10	25.5	25.48	0.10	0	08457	QPSK	1	0	10 mm	back	1:1	1.160	1.005	1.166	A30
2310.00	27710	Mid	LTE Band 30	10	24.5	24.48	0.05	1	08457	QPSK	25	12	10 mm	back	1:1	0.944	1.005	0.949	
2310.00	27710	Mid	LTE Band 30	10	24.5	24.33	0.05	1	08457	QPSK	50	0	10 mm	back	1:1	0.949	1.040	0.987	
2310.00	27710	Mid	LTE Band 30	10	25.5	25.48	0.04	0	08457	QPSK	1	0	10 mm	back	1:1	1.030	1.005	1.035	
2560.00	21350	High	LTE Band 7	20	25.5	25.50	-0.10	0	08515	QPSK	1	0	10 mm	back	1:1	0.317	1.000	0.317	A31
2535.00	21100	Mid	LTE Band 7	20	24.5	24.49	0.02	1	08515	QPSK	50	25	10 mm	back	1:1	0.196	1.002	0.196	
ANSI / IEEE C95.1 1992 - SAFETY LIMIT Spatial Peak Uncontrolled Exposure/General Population									Body 1.6 W/kg (mW/g) averaged over 1 gram										

Note: Blue entry represents variability measurement

**Table 11-17
DTS Body-Worn SAR**

MEASUREMENT RESULTS																			
FREQUENCY		Mode	Service	Bandwidth [MHz]	Maximum Allowed Power [dBm]	Conducted Power [dBm]	Power Drift [dB]	Spacing	Antenna Config.	Device Serial Number	Data Rate (Mbps)	Side	Duty Cycle (%)	Peak SAR of Area Scan (W/kg)	SAR (1g) (W/kg)	Scaling Factor (Power)	Scaling Factor (Duty Cycle)	Reported SAR (1g) (W/kg)	Plot #
MHz	Ch.																		
2437	6	802.11b	DSSS	22	20.0	19.81	0.18	10 mm	Primary	08564	1	back	99.9	0.424	0.293	1.045	1.001	0.306	
2437	6	802.11b	DSSS	22	19.5	18.52	-0.01	10 mm	Secondary	08564	1	back	99.9	0.505	0.332	1.253	1.001	0.416	A33
ANSI / IEEE C95.1 1992 - SAFETY LIMIT Spatial Peak Uncontrolled Exposure/General Population									Body 1.6 W/kg (mW/g) averaged over 1 gram										



FCC ID: ZNFH871		SAR EVALUATION REPORT		Approved by: Quality Manager
Document S/N: 1M1701180032-01-R4.ZNF	Test Dates: 01/20/17 - 01/30/17	DUT Type: Portable Handset	Page 60 of 97	

**Table 11-18
NII Body-Worn SAR**

MEASUREMENT RESULTS																			
FREQUENCY		Mode	Service	Bandwidth [MHz]	Maximum Allowed Power [dBm]	Conducted Power [dBm]	Power Drift [dB]	Spacing	Antenna Config.	Device Serial Number	Data Rate (Mbps)	Side	Duty Cycle (%)	Peak SAR of Area Scan	SAR (1g)	Scaling Factor (Power)	Scaling Factor (Duty Cycle)	Reported SAR (1g)	Plot #
MHz	Ch.													(W/kg)	(W/kg)			(W/kg)	
5300	60	802.11a	OFDM	20	16.5	16.05	0.11	10 mm	Primary	08564	6	back	99.3	0.707	0.360	1.109	1.007	0.402	
5280	56	802.11a	OFDM	20	16.5	15.76	0.08	10 mm	Secondary	08564	6	back	99.3	0.646	0.305	1.166	1.007	0.364	
5580	116	802.11a	OFDM	20	16.5	15.86	0.09	10 mm	Primary	08564	6	back	99.3	0.705	0.409	1.159	1.007	0.477	
5660	132	802.11a	OFDM	20	16.5	16.10	0.20	10 mm	Secondary	08564	6	back	99.3	0.242	0.121	1.096	1.007	0.134	
5745	149	802.11a	OFDM	20	16.5	16.36	0.10	10 mm	Primary	08564	6	back	99.3	0.834	0.481	1.033	1.007	0.500	A34
5745	149	802.11a	OFDM	20	16.5	16.44	0.19	10 mm	Secondary	08564	6	back	99.3	0.083	0.037	1.014	1.007	0.038	
ANSI / IEEE C95.1 1992 - SAFETY LIMIT Spatial Peak Uncontrolled Exposure/General Population								Body 1.6 W/kg (mW/g) averaged over 1 gram											

**Table 11-19
Bluetooth Body-Worn SAR**

MEASUREMENT RESULTS																
FREQUENCY		Mode	Service	Maximum Allowed Power [dBm]	Conducted Power [dBm]	Power Drift [dB]	Spacing	Device Serial Number	Data Rate (Mbps)	Side	Duty Cycle (%)	SAR (1g)	Scaling Factor (Power)	Scaling Factor (Duty Cycle)	Reported SAR (1g)	Plot #
MHz	Ch.											(W/kg)			(W/kg)	
2441	39	Bluetooth	FHSS	12.5	10.65	0.13	10 mm	08564	1	back	77.2	0.053	1.531	1.295	0.105	A35
ANSI / IEEE C95.1 1992 - SAFETY LIMIT Spatial Peak Uncontrolled Exposure/General Population								Body 1.6 W/kg (mW/g) averaged over 1 gram								



FCC ID: ZNFH871		SAR EVALUATION REPORT		Approved by: Quality Manager
Document S/N: 1M1701180032-01-R4.ZNF	Test Dates: 01/20/17 - 01/30/17	DUT Type: Portable Handset		Page 61 of 97

11.3 Standalone Hotspot SAR Data

**Table 11-20
GPRS/UMTS Hotspot SAR Data**

MEASUREMENT RESULTS															
FREQUENCY		Mode	Service	Maximum Allowed Power [dBm]	Conducted Power [dBm]	Power Drift [dB]	Spacing	Device Serial Number	# of GPRS Slots	Duty Cycle	Side	SAR (1g)	Scaling Factor	Reported SAR (1g)	Plot #
MHz	Ch.											(W/kg)		(W/kg)	
824.20	128	GSM 850	GPRS	30.2	30.14	0.00	10 mm	08465	3	1:2.76	back	0.815	1.014	0.826	
836.60	190	GSM 850	GPRS	30.2	30.20	-0.01	10 mm	08465	3	1:2.76	back	0.948	1.000	0.948	
848.80	251	GSM 850	GPRS	30.2	30.20	0.00	10 mm	08465	3	1:2.76	back	0.989	1.000	0.989	
824.20	128	GSM 850	GPRS	30.2	30.14	-0.11	10 mm	08465	3	1:2.76	front	0.912	1.014	0.925	
836.60	190	GSM 850	GPRS	30.2	30.20	-0.18	10 mm	08465	3	1:2.76	front	1.060	1.000	1.060	A16
848.80	251	GSM 850	GPRS	30.2	30.20	-0.07	10 mm	08465	3	1:2.76	front	1.050	1.000	1.050	
836.60	190	GSM 850	GPRS	30.2	30.20	-0.10	10 mm	08465	3	1:2.76	bottom	0.529	1.000	0.529	
836.60	190	GSM 850	GPRS	30.2	30.20	-0.08	10 mm	08465	3	1:2.76	right	0.229	1.000	0.229	
836.60	190	GSM 850	GPRS	30.2	30.20	-0.02	10 mm	08465	3	1:2.76	left	0.499	1.000	0.499	
836.60	190	GSM 850	GPRS	30.2	30.20	-0.08	10 mm	08465	3	1:2.76	front	1.040	1.000	1.040	
836.60	4183	UMTS 850	RMC	24.7	24.65	-0.02	10 mm	08465	N/A	1:1	back	0.254	1.012	0.257	A17
836.60	4183	UMTS 850	RMC	24.7	24.65	-0.01	10 mm	08465	N/A	1:1	front	0.248	1.012	0.251	
836.60	4183	UMTS 850	RMC	24.7	24.65	0.01	10 mm	08465	N/A	1:1	bottom	0.119	1.012	0.120	
836.60	4183	UMTS 850	RMC	24.7	24.65	0.01	10 mm	08465	N/A	1:1	right	0.052	1.012	0.053	
836.60	4183	UMTS 850	RMC	24.7	24.65	0.00	10 mm	08465	N/A	1:1	left	0.111	1.012	0.112	
1712.40	1312	UMTS 1750	RMC	25.0	24.96	-0.07	10 mm	08473	N/A	1:1	back	0.728	1.009	0.735	
1732.40	1412	UMTS 1750	RMC	25.0	24.98	0.01	10 mm	08473	N/A	1:1	back	0.882	1.005	0.886	
1752.60	1513	UMTS 1750	RMC	25.0	24.90	0.05	10 mm	08473	N/A	1:1	back	0.936	1.023	0.958	A18
1732.40	1412	UMTS 1750	RMC	25.0	24.98	0.00	10 mm	08473	N/A	1:1	front	0.654	1.005	0.657	
1732.40	1412	UMTS 1750	RMC	25.0	24.98	-0.04	10 mm	08473	N/A	1:1	bottom	0.384	1.005	0.386	
1732.40	1412	UMTS 1750	RMC	25.0	24.98	-0.03	10 mm	08473	N/A	1:1	left	0.255	1.005	0.256	
1880.00	661	GSM 1900	GPRS	27.2	27.20	0.00	10 mm	08465	3	1:2.76	back	0.316	1.000	0.316	
1880.00	661	GSM 1900	GPRS	27.2	27.20	-0.01	10 mm	08465	3	1:2.76	front	0.301	1.000	0.301	
1880.00	661	GSM 1900	GPRS	27.2	27.20	0.04	10 mm	08465	3	1:2.76	bottom	0.406	1.000	0.406	A20
1880.00	661	GSM 1900	GPRS	27.2	27.20	-0.12	10 mm	08465	3	1:2.76	left	0.162	1.000	0.162	
1880.00	9400	UMTS 1900	RMC	25.0	25.00	-0.10	10 mm	08465	N/A	1:1	back	0.789	1.000	0.789	A21
1880.00	9400	UMTS 1900	RMC	25.0	25.00	-0.02	10 mm	08465	N/A	1:1	front	0.718	1.000	0.718	
1880.00	9400	UMTS 1900	RMC	25.0	25.00	-0.02	10 mm	08465	N/A	1:1	bottom	0.736	1.000	0.736	
1880.00	9400	UMTS 1900	RMC	25.0	25.00	0.03	10 mm	08465	N/A	1:1	left	0.408	1.000	0.408	
ANSI / IEEE C95.1 1992 - SAFETY LIMIT Spatial Peak Uncontrolled Exposure/General Population								Body 1.6 W/kg (mW/g) averaged over 1 gram							

Note: Blue entry represents variability measurement



FCC ID: ZNFH871		SAR EVALUATION REPORT		Approved by: Quality Manager
Document S/N: 1M1701180032-01-R4.ZNF	Test Dates: 01/20/17 - 01/30/17	DUT Type: Portable Handset	Page 62 of 97	

**Table 11-21
LTE Band 12 Hotspot SAR**

MEASUREMENT RESULTS																			
FREQUENCY		Mode	Bandwidth [MHz]	Maximum Allowed Power [dBm]	Conducted Power [dBm]	Power Drift [dB]	MPR [dB]	Device Serial Number	Modulation	RB Size	RB Offset	Spacing	Side	Duty Cycle	SAR (1g)	Scaling Factor	Reported SAR (1g)	Plot #	
MHz	Ch.														(W/kg)		(W/kg)		
707.50	23095	Mid	LTE Band 12	10	25.5	25.50	0.01	0	08440	QPSK	1	0	10 mm	back	1:1	0.688	1.000	0.688	
707.50	23095	Mid	LTE Band 12	10	24.5	24.48	-0.02	1	08440	QPSK	25	25	10 mm	back	1:1	0.562	1.005	0.565	
707.50	23095	Mid	LTE Band 12	10	25.5	25.50	-0.01	0	08440	QPSK	1	0	10 mm	front	1:1	0.742	1.000	0.742	A23
707.50	23095	Mid	LTE Band 12	10	24.5	24.48	0.02	1	08440	QPSK	25	25	10 mm	front	1:1	0.610	1.005	0.613	
707.50	23095	Mid	LTE Band 12	10	25.5	25.50	-0.02	0	08440	QPSK	1	0	10 mm	bottom	1:1	0.426	1.000	0.426	
707.50	23095	Mid	LTE Band 12	10	24.5	24.48	-0.06	1	08440	QPSK	25	25	10 mm	bottom	1:1	0.350	1.005	0.352	
707.50	23095	Mid	LTE Band 12	10	25.5	25.50	-0.06	0	08440	QPSK	1	0	10 mm	right	1:1	0.294	1.000	0.294	
707.50	23095	Mid	LTE Band 12	10	24.5	24.48	-0.04	1	08440	QPSK	25	25	10 mm	right	1:1	0.225	1.005	0.226	
707.50	23095	Mid	LTE Band 12	10	25.5	25.50	0.01	0	08440	QPSK	1	0	10 mm	left	1:1	0.264	1.000	0.264	
707.50	23095	Mid	LTE Band 12	10	24.5	24.48	0.01	1	08440	QPSK	25	25	10 mm	left	1:1	0.239	1.005	0.240	
ANSI / IEEE C95.1 1992 - SAFETY LIMIT Spatial Peak Uncontrolled Exposure/General Population								Body 1.6 W/kg (mW/g) averaged over 1 gram											

**Table 11-22
LTE Band 13 Hotspot SAR**

MEASUREMENT RESULTS																			
FREQUENCY		Mode	Bandwidth [MHz]	Maximum Allowed Power [dBm]	Conducted Power [dBm]	Power Drift [dB]	MPR [dB]	Device Serial Number	Modulation	RB Size	RB Offset	Spacing	Side	Duty Cycle	SAR (1g)	Scaling Factor	Reported SAR (1g)	Plot #	
MHz	Ch.														(W/kg)		(W/kg)		
782.00	23230	Mid	LTE Band 13	10	25.5	25.20	0.07	0	08440	QPSK	1	0	10 mm	back	1:1	0.442	1.072	0.474	A24
782.00	23230	Mid	LTE Band 13	10	24.5	24.16	-0.01	1	08440	QPSK	25	12	10 mm	back	1:1	0.320	1.081	0.346	
782.00	23230	Mid	LTE Band 13	10	25.5	25.20	-0.02	0	08440	QPSK	1	0	10 mm	front	1:1	0.405	1.072	0.434	
782.00	23230	Mid	LTE Band 13	10	24.5	24.16	-0.01	1	08440	QPSK	25	12	10 mm	front	1:1	0.293	1.081	0.317	
782.00	23230	Mid	LTE Band 13	10	25.5	25.20	-0.01	0	08440	QPSK	1	0	10 mm	bottom	1:1	0.229	1.072	0.245	
782.00	23230	Mid	LTE Band 13	10	24.5	24.16	-0.02	1	08440	QPSK	25	12	10 mm	bottom	1:1	0.167	1.081	0.181	
782.00	23230	Mid	LTE Band 13	10	25.5	25.20	-0.02	0	08440	QPSK	1	0	10 mm	right	1:1	0.124	1.072	0.133	
782.00	23230	Mid	LTE Band 13	10	24.5	24.16	0.00	1	08440	QPSK	25	12	10 mm	right	1:1	0.083	1.081	0.090	
782.00	23230	Mid	LTE Band 13	10	25.5	25.20	0.00	0	08440	QPSK	1	0	10 mm	left	1:1	0.192	1.072	0.206	
782.00	23230	Mid	LTE Band 13	10	24.5	24.16	0.00	1	08440	QPSK	25	12	10 mm	left	1:1	0.150	1.081	0.162	
ANSI / IEEE C95.1 1992 - SAFETY LIMIT Spatial Peak Uncontrolled Exposure/General Population								Body 1.6 W/kg (mW/g) averaged over 1 gram											

FCC ID: ZNFH871		SAR EVALUATION REPORT		Approved by: Quality Manager
Document S/N: 1M1701180032-01-R4.ZNF	Test Dates: 01/20/17 - 01/30/17	DUT Type: Portable Handset	Page 63 of 97	



**Table 11-23
LTE Band 5 (Cell) Hotspot SAR**

MEASUREMENT RESULTS																			
FREQUENCY		Mode	Bandwidth [MHz]	Maximum Allowed Power [dBm]	Conducted Power [dBm]	Power Drift [dB]	MPR [dB]	Device Serial Number	Modulation	RB Size	RB Offset	Spacing	Side	Duty Cycle	SAR (1g) (W/kg)	Scaling Factor	Reported SAR (1g) (W/kg)	Plot #	
MHz	Ch.																		
836.50	20525	Mid	LTE Band 5 (Cell)	10	25.5	25.50	-0.10	0	08440	QPSK	1	0	10 mm	back	1:1	0.495	1.000	0.495	
836.50	20525	Mid	LTE Band 5 (Cell)	10	24.5	24.47	0.05	1	08440	QPSK	25	12	10 mm	back	1:1	0.406	1.007	0.409	
836.50	20525	Mid	LTE Band 5 (Cell)	10	25.5	25.50	0.00	0	08440	QPSK	1	0	10 mm	front	1:1	0.497	1.000	0.497	A26
836.50	20525	Mid	LTE Band 5 (Cell)	10	24.5	24.47	0.01	1	08440	QPSK	25	12	10 mm	front	1:1	0.419	1.007	0.422	
836.50	20525	Mid	LTE Band 5 (Cell)	10	25.5	25.50	-0.11	0	08440	QPSK	1	0	10 mm	bottom	1:1	0.328	1.000	0.328	
836.50	20525	Mid	LTE Band 5 (Cell)	10	24.5	24.47	-0.13	1	08440	QPSK	25	12	10 mm	bottom	1:1	0.278	1.007	0.280	
836.50	20525	Mid	LTE Band 5 (Cell)	10	25.5	25.50	-0.03	0	08440	QPSK	1	0	10 mm	right	1:1	0.130	1.000	0.130	
836.50	20525	Mid	LTE Band 5 (Cell)	10	24.5	24.47	0.01	1	08440	QPSK	25	12	10 mm	right	1:1	0.114	1.007	0.115	
836.50	20525	Mid	LTE Band 5 (Cell)	10	25.5	25.50	0.03	0	08440	QPSK	1	0	10 mm	left	1:1	0.285	1.000	0.285	
836.50	20525	Mid	LTE Band 5 (Cell)	10	24.5	24.47	0.15	1	08440	QPSK	25	12	10 mm	left	1:1	0.237	1.007	0.239	
ANSI / IEEE C95.1 1992 - SAFETY LIMIT Spatial Peak Uncontrolled Exposure/General Population										Body 1.6 W/kg (mW/g) averaged over 1 gram									

**Table 11-24
LTE Band 66 (AWS) Hotspot SAR**

MEASUREMENT RESULTS																			
FREQUENCY		Mode	Bandwidth [MHz]	Maximum Allowed Power [dBm]	Conducted Power [dBm]	Power Drift [dB]	MPR [dB]	Device Serial Number	Modulation	RB Size	RB Offset	Spacing	Side	Duty Cycle	SAR (1g) (W/kg)	Scaling Factor	Reported SAR (1g) (W/kg)	Plot #	
MHz	Ch.																		
1720.00	132072	Low	LTE Band 66 (AWS)	20	25.5	25.50	0.00	0	08440	QPSK	1	99	10 mm	back	1:1	1.060	1.000	1.060	
1745.00	132322	Mid	LTE Band 66 (AWS)	20	25.5	25.46	-0.02	0	08440	QPSK	1	50	10 mm	back	1:1	1.100	1.009	1.110	A27
1770.00	132572	High	LTE Band 66 (AWS)	20	25.5	25.49	0.02	0	08440	QPSK	1	50	10 mm	back	1:1	0.994	1.002	0.996	
1720.00	132072	Low	LTE Band 66 (AWS)	20	24.5	24.45	0.03	1	08440	QPSK	50	0	10 mm	back	1:1	0.906	1.012	0.917	
1745.00	132322	Mid	LTE Band 66 (AWS)	20	24.5	24.50	0.02	1	08440	QPSK	50	0	10 mm	back	1:1	0.946	1.000	0.946	
1770.00	132572	High	LTE Band 66 (AWS)	20	24.5	24.48	-0.01	1	08440	QPSK	50	0	10 mm	back	1:1	0.853	1.005	0.857	
1770.00	132572	High	LTE Band 66 (AWS)	20	24.5	24.48	-0.01	1	08440	QPSK	100	0	10 mm	back	1:1	0.863	1.005	0.867	
1720.00	132072	Low	LTE Band 66 (AWS)	20	25.5	25.50	-0.02	0	08440	QPSK	1	99	10 mm	front	1:1	1.100	1.000	1.100	
1745.00	132322	Mid	LTE Band 66 (AWS)	20	25.5	25.46	-0.06	0	08440	QPSK	1	50	10 mm	front	1:1	0.880	1.009	0.888	
1770.00	132572	High	LTE Band 66 (AWS)	20	25.5	25.49	0.03	0	08440	QPSK	1	50	10 mm	front	1:1	0.919	1.002	0.921	
1720.00	132072	Low	LTE Band 66 (AWS)	20	24.5	24.45	0.04	1	08440	QPSK	50	0	10 mm	front	1:1	0.782	1.012	0.791	
1745.00	132322	Mid	LTE Band 66 (AWS)	20	24.5	24.50	0.02	1	08440	QPSK	50	0	10 mm	front	1:1	0.764	1.000	0.764	
1770.00	132572	High	LTE Band 66 (AWS)	20	24.5	24.48	0.04	1	08440	QPSK	50	0	10 mm	front	1:1	0.817	1.005	0.821	
1770.00	132572	High	LTE Band 66 (AWS)	20	24.5	24.48	-0.08	1	08440	QPSK	100	0	10 mm	front	1:1	0.812	1.005	0.816	
1720.00	132072	Low	LTE Band 66 (AWS)	20	25.5	25.50	0.00	0	08440	QPSK	1	99	10 mm	bottom	1:1	1.020	1.000	1.020	
1745.00	132322	Mid	LTE Band 66 (AWS)	20	25.5	25.46	0.02	0	08440	QPSK	1	50	10 mm	bottom	1:1	0.862	1.009	0.870	
1770.00	132572	High	LTE Band 66 (AWS)	20	25.5	25.49	0.03	0	08440	QPSK	1	50	10 mm	bottom	1:1	1.040	1.002	1.042	
1745.00	132322	Mid	LTE Band 66 (AWS)	20	24.5	24.50	0.02	1	08440	QPSK	50	0	10 mm	bottom	1:1	0.760	1.000	0.760	
1770.00	132572	High	LTE Band 66 (AWS)	20	24.5	24.48	-0.01	1	08440	QPSK	100	0	10 mm	bottom	1:1	0.924	1.005	0.929	
1720.00	132072	Low	LTE Band 66 (AWS)	20	25.5	25.50	0.03	0	08440	QPSK	1	99	10 mm	left	1:1	0.450	1.000	0.450	
1745.00	132322	Mid	LTE Band 66 (AWS)	20	24.5	24.50	0.01	1	08440	QPSK	50	0	10 mm	left	1:1	0.407	1.000	0.407	
1745.00	132322	Mid	LTE Band 66 (AWS)	20	25.5	25.46	0.00	0	08440	QPSK	1	50	10 mm	back	1:1	1.030	1.009	1.039	
ANSI / IEEE C95.1 1992 - SAFETY LIMIT Spatial Peak Uncontrolled Exposure/General Population										Body 1.6 W/kg (mW/g) averaged over 1 gram									

Note: Blue entry represents variability measurement

FCC ID: ZNFH871		SAR EVALUATION REPORT		Approved by: Quality Manager
Document S/N: 1M1701180032-01-R4.ZNF	Test Dates: 01/20/17 - 01/30/17	DUT Type: Portable Handset		Page 64 of 97

**Table 11-25
LTE Band 25 (PCS) Hotspot SAR**



MEASUREMENT RESULTS																			
FREQUENCY		Mode	Bandwidth [MHz]	Maximum Allowed Power [dBm]	Conducted Power [dBm]	Power Drift [dB]	MPR [dB]	Device Serial Number	Modulation	RB Size	RB Offset	Spacing	Side	Duty Cycle	SAR (1g) (W/kg)	Scaling Factor	Reported SAR (1g) (W/kg)	Plot #	
MHz	Ch.																		
1860.00	26140	Low	LTE Band 25 (PCS)	20	25.0	24.98	0.02	0	08457	QPSK	1	50	10 mm	back	1:1	0.974	1.005	0.979	
1882.50	26365	Mid	LTE Band 25 (PCS)	20	25.0	25.00	-0.05	0	08457	QPSK	1	0	10 mm	back	1:1	0.898	1.000	0.898	
1905.00	26590	High	LTE Band 25 (PCS)	20	25.0	24.97	-0.01	0	08457	QPSK	1	50	10 mm	back	1:1	0.729	1.007	0.734	
1882.50	26365	Mid	LTE Band 25 (PCS)	20	24.0	24.00	-0.10	1	08457	QPSK	50	0	10 mm	back	1:1	0.677	1.000	0.677	
1905.00	26590	High	LTE Band 25 (PCS)	20	24.0	23.99	-0.08	1	08457	QPSK	100	0	10 mm	back	1:1	0.652	1.002	0.653	
1860.00	26140	Low	LTE Band 25 (PCS)	20	25.0	24.98	-0.01	0	08457	QPSK	1	50	10 mm	front	1:1	0.722	1.005	0.726	
1882.50	26365	Mid	LTE Band 25 (PCS)	20	25.0	25.00	-0.02	0	08457	QPSK	1	0	10 mm	front	1:1	0.823	1.000	0.823	
1905.00	26590	High	LTE Band 25 (PCS)	20	25.0	24.97	-0.04	0	08457	QPSK	1	50	10 mm	front	1:1	0.629	1.007	0.633	
1882.50	26365	Mid	LTE Band 25 (PCS)	20	24.0	24.00	0.01	1	08457	QPSK	50	0	10 mm	front	1:1	0.603	1.000	0.603	
1905.00	26590	High	LTE Band 25 (PCS)	20	24.0	23.99	-0.02	1	08457	QPSK	100	0	10 mm	front	1:1	0.555	1.002	0.556	
1860.00	26140	Low	LTE Band 25 (PCS)	20	25.0	24.98	0.06	0	08457	QPSK	1	50	10 mm	bottom	1:1	1.130	1.005	1.136	
1882.50	26365	Mid	LTE Band 25 (PCS)	20	25.0	25.00	-0.03	0	08457	QPSK	1	0	10 mm	bottom	1:1	1.190	1.000	1.190	A29
1905.00	26590	High	LTE Band 25 (PCS)	20	25.0	24.97	0.07	0	08457	QPSK	1	50	10 mm	bottom	1:1	0.852	1.007	0.858	
1860.00	26140	Low	LTE Band 25 (PCS)	20	24.0	23.99	0.05	1	08457	QPSK	50	0	10 mm	bottom	1:1	0.943	1.002	0.945	
1882.50	26365	Mid	LTE Band 25 (PCS)	20	24.0	24.00	0.00	1	08457	QPSK	50	0	10 mm	bottom	1:1	0.851	1.000	0.851	
1905.00	26590	High	LTE Band 25 (PCS)	20	24.0	23.98	0.07	1	08457	QPSK	50	0	10 mm	bottom	1:1	0.765	1.005	0.769	
1905.00	26590	High	LTE Band 25 (PCS)	20	24.0	23.99	0.09	1	08457	QPSK	100	0	10 mm	bottom	1:1	0.769	1.002	0.771	
1882.50	26365	Mid	LTE Band 25 (PCS)	20	25.0	25.00	-0.10	0	08457	QPSK	1	0	10 mm	left	1:1	0.393	1.000	0.393	
1882.50	26365	Mid	LTE Band 25 (PCS)	20	24.0	24.00	-0.02	1	08457	QPSK	50	0	10 mm	left	1:1	0.295	1.000	0.295	
1882.50	26365	Mid	LTE Band 25 (PCS)	20	25.0	25.00	-0.12	0	08457	QPSK	1	0	10 mm	bottom	1:1	1.080	1.000	1.080	
ANSI / IEEE C95.1 1992 - SAFETY LIMIT										Body									
Spatial Peak										1.6 W/kg (mW/g)									
Uncontrolled Exposure/General Population										averaged over 1 gram									

Note: Blue entry represents variability measurement

**Table 11-26
LTE Band 30 Hotspot SAR**

MEASUREMENT RESULTS																			
FREQUENCY		Mode	Bandwidth [MHz]	Maximum Allowed Power [dBm]	Conducted Power [dBm]	Power Drift [dB]	MPR [dB]	Device Serial Number	Modulation	RB Size	RB Offset	Spacing	Side	Duty Cycle	SAR (1g) (W/kg)	Scaling Factor	Reported SAR (1g) (W/kg)	Plot #	
MHz	Ch.																		
2310.00	27710	Mid	LTE Band 30	10	25.5	25.48	0.10	0	08457	QPSK	1	0	10 mm	back	1:1	1.160	1.005	1.166	A30
2310.00	27710	Mid	LTE Band 30	10	24.5	24.48	0.05	1	08457	QPSK	25	12	10 mm	back	1:1	0.944	1.005	0.949	
2310.00	27710	Mid	LTE Band 30	10	24.5	24.33	0.05	1	08457	QPSK	50	0	10 mm	back	1:1	0.949	1.040	0.987	
2310.00	27710	Mid	LTE Band 30	10	25.5	25.48	0.01	0	08457	QPSK	1	0	10 mm	front	1:1	0.276	1.005	0.277	
2310.00	27710	Mid	LTE Band 30	10	24.5	24.48	0.02	1	08457	QPSK	25	12	10 mm	front	1:1	0.224	1.005	0.225	
2310.00	27710	Mid	LTE Band 30	10	25.5	25.48	-0.02	0	08457	QPSK	1	0	10 mm	bottom	1:1	0.350	1.005	0.352	
2310.00	27710	Mid	LTE Band 30	10	24.5	24.48	0.05	1	08457	QPSK	25	12	10 mm	bottom	1:1	0.281	1.005	0.282	
2310.00	27710	Mid	LTE Band 30	10	25.5	25.48	0.10	0	08457	QPSK	1	0	10 mm	right	1:1	0.143	1.005	0.144	
2310.00	27710	Mid	LTE Band 30	10	24.5	24.48	-0.02	1	08457	QPSK	25	12	10 mm	right	1:1	0.116	1.005	0.117	
2310.00	27710	Mid	LTE Band 30	10	25.5	25.48	0.12	0	08457	QPSK	1	0	10 mm	left	1:1	0.027	1.005	0.027	
2310.00	27710	Mid	LTE Band 30	10	24.5	24.48	0.06	1	08457	QPSK	25	12	10 mm	left	1:1	0.022	1.005	0.022	
2310.00	27710	Mid	LTE Band 30	10	25.5	25.48	0.04	0	08457	QPSK	1	0	10 mm	back	1:1	1.030	1.005	1.035	
ANSI / IEEE C95.1 1992 - SAFETY LIMIT										Body									
Spatial Peak										1.6 W/kg (mW/g)									
Uncontrolled Exposure/General Population										averaged over 1 gram									

Note: Blue entry represents variability measurement



FCC ID: ZNFH871		SAR EVALUATION REPORT		Approved by: Quality Manager
Document S/N: 1M1701180032-01-R4.ZNF	Test Dates: 01/20/17 - 01/30/17	DUT Type: Portable Handset	Page 65 of 97	

**Table 11-27
LTE Band 7 Hotspot SAR**

MEASUREMENT RESULTS																			
FREQUENCY		Mode	Bandwidth [MHz]	Maximum Allowed Power [dBm]	Conducted Power [dBm]	Power Drift [dB]	MPR [dB]	Device Serial Number	Modulation	RB Size	RB Offset	Spacing	Side	Duty Cycle	SAR (1g) (W/kg)	Scaling Factor	Reported SAR (1g) (W/kg)	Plot #	
MHz	Ch.																		
2560.00	21350	High	LTE Band 7	20	25.5	25.50	-0.10	0	08515	QPSK	1	0	10 mm	back	1:1	0.317	1.000	0.317	
2535.00	21100	Mid	LTE Band 7	20	24.5	24.49	0.02	1	08515	QPSK	50	25	10 mm	back	1:1	0.196	1.002	0.196	
2560.00	21350	High	LTE Band 7	20	25.5	25.50	0.01	0	08515	QPSK	1	0	10 mm	front	1:1	0.263	1.000	0.263	
2535.00	21100	Mid	LTE Band 7	20	24.5	24.49	0.03	1	08515	QPSK	50	25	10 mm	front	1:1	0.169	1.002	0.169	
2560.00	21350	High	LTE Band 7	20	25.5	25.50	0.00	0	08515	QPSK	1	0	10 mm	bottom	1:1	0.447	1.000	0.447	A32
2535.00	21100	Mid	LTE Band 7	20	24.5	24.49	-0.20	1	08515	QPSK	50	25	10 mm	bottom	1:1	0.285	1.002	0.286	
2560.00	21350	High	LTE Band 7	20	25.5	25.50	0.08	0	08515	QPSK	1	0	10 mm	left	1:1	0.085	1.000	0.085	
2535.00	21100	Mid	LTE Band 7	20	24.5	24.49	0.13	1	08515	QPSK	50	25	10 mm	left	1:1	0.056	1.002	0.056	
ANSI / IEEE C95.1 1992 - SAFETY LIMIT Spatial Peak Uncontrolled Exposure/General Population										Body 1.6 W/kg (mW/g) averaged over 1 gram									

**Table 11-28
WLAN Hotspot SAR**

MEASUREMENT RESULTS																			
FREQUENCY		Mode	Service	Bandwidth [MHz]	Maximum Allowed Power [dBm]	Conducted Power [dBm]	Power Drift [dB]	Spacing	Antenna Config.	Device Serial Number	Data Rate (Mbps)	Side	Duty Cycle (%)	Peak SAR of Area Scan W/kg	SAR (1g) (W/kg)	Scaling Factor (Power)	Scaling Factor (Duty Cycle)	Reported SAR (1g) (W/kg)	Plot #
MHz	Ch.																		
2437	6	802.11b	DSSS	22	20.0	19.81	0.18	10 mm	Primary	08564	1	back	99.9	0.424	0.293	1.045	1.001	0.306	
2437	6	802.11b	DSSS	22	20.0	19.81	0.00	10 mm	Primary	08564	1	front	99.9	0.460	0.312	1.045	1.001	0.326	
2437	6	802.11b	DSSS	22	20.0	19.81	0.12	10 mm	Primary	08564	1	top	99.9	0.092	-	1.045	1.001	-	
2437	6	802.11b	DSSS	22	20.0	19.81	-0.01	10 mm	Primary	08564	1	left	99.9	0.499	0.322	1.045	1.001	0.337	
2437	6	802.11b	DSSS	22	19.5	18.52	-0.01	10 mm	Secondary	08564	1	back	99.9	0.505	0.332	1.253	1.001	0.416	A33
2437	6	802.11b	DSSS	22	19.5	18.52	0.11	10 mm	Secondary	08564	1	front	99.9	0.457	0.318	1.253	1.001	0.399	
2437	6	802.11b	DSSS	22	19.5	18.52	0.12	10 mm	Secondary	08564	1	top	99.9	0.451	-	1.253	1.001	-	
2437	6	802.11b	DSSS	22	19.5	18.52	0.15	10 mm	Secondary	08564	1	left	99.9	0.047	-	1.253	1.001	-	
5200	40	802.11a	OFDM	20	16.5	16.18	0.10	10 mm	Primary	08564	6	back	99.3	0.666	0.364	1.076	1.007	0.394	
5200	40	802.11a	OFDM	20	16.5	16.18	-0.12	10 mm	Primary	08564	6	front	99.3	0.032	0.029	1.076	1.007	0.031	
5200	40	802.11a	OFDM	20	16.5	16.18	0.14	10 mm	Primary	08564	6	top	99.3	0.084	-	1.076	1.007	-	
5200	40	802.11a	OFDM	20	16.5	16.18	0.11	10 mm	Primary	08564	6	left	99.3	0.198	-	1.076	1.007	-	
5240	48	802.11a	OFDM	20	16.5	15.97	0.10	10 mm	Secondary	08564	6	back	99.3	0.573	0.289	1.130	1.007	0.329	
5240	48	802.11a	OFDM	20	16.5	15.97	0.11	10 mm	Secondary	08564	6	front	99.3	0.244	0.137	1.130	1.007	0.156	
5240	48	802.11a	OFDM	20	16.5	15.97	0.13	10 mm	Secondary	08564	6	top	99.3	0.379	-	1.130	1.007	-	
5240	48	802.11a	OFDM	20	16.5	15.97	0.19	10 mm	Secondary	08564	6	left	99.3	0.114	-	1.130	1.007	-	
5745	149	802.11a	OFDM	20	16.5	16.36	0.10	10 mm	Primary	08564	6	back	99.3	0.834	0.481	1.033	1.007	0.500	A34
5745	149	802.11a	OFDM	20	16.5	16.36	0.13	10 mm	Primary	08564	6	front	99.3	0.071	0.045	1.033	1.007	0.047	
5745	149	802.11a	OFDM	20	16.5	16.36	0.10	10 mm	Primary	08564	6	top	99.3	0.149	-	1.033	1.007	-	
5745	149	802.11a	OFDM	20	16.5	16.36	0.16	10 mm	Primary	08564	6	left	99.3	0.418	0.192	1.033	1.007	0.200	
5745	149	802.11a	OFDM	20	16.5	16.44	0.19	10 mm	Secondary	08564	6	back	99.3	0.083	0.037	1.014	1.007	0.038	
5745	149	802.11a	OFDM	20	16.5	16.44	0.11	10 mm	Secondary	08564	6	front	99.3	0.019	0.016	1.014	1.007	0.016	
5745	149	802.11a	OFDM	20	16.5	16.44	0.15	10 mm	Secondary	08564	6	top	99.3	0.092	0.054	1.014	1.007	0.055	
5745	149	802.11a	OFDM	20	16.5	16.44	0.12	10 mm	Secondary	08564	6	left	99.3	0.018	-	1.014	1.007	-	
ANSI / IEEE C95.1 1992 - SAFETY LIMIT Spatial Peak Uncontrolled Exposure/General Population										Body 1.6 W/kg (mW/g) averaged over 1 gram									

FCC ID: ZNFH871		SAR EVALUATION REPORT		Approved by: Quality Manager
Document S/N: 1M1701180032-01-R4.ZNF	Test Dates: 01/20/17 - 01/30/17	DUT Type: Portable Handset		Page 66 of 97

11.4 SAR Test Notes

General Notes:



1. The test data reported are the worst-case SAR values according to test procedures specified in IEEE 1528-2013, and FCC KDB Publication 447498 D01v06.
2. Batteries are fully charged at the beginning of the SAR measurements.
3. Liquid tissue depth was at least 15.0 cm for all frequencies.
4. The manufacturer has confirmed that the device(s) tested have the same physical, mechanical and thermal characteristics and are within operational tolerances expected for production units.
5. SAR results were scaled to the maximum allowed power to demonstrate compliance per FCC KDB Publication 447498 D01v06.
6. Device was tested using a fixed spacing for body-worn accessory testing. A separation distance of 10 mm was considered because the manufacturer has determined that there will be body-worn accessories available in the marketplace for users to support this separation distance.
7. Per FCC KDB Publication 648474 D04v01r03, body-worn SAR was evaluated without a headset connected to the device. Since the standalone reported body-worn SAR was ≤ 1.2 W/kg, no additional body-worn SAR evaluations using a headset cable were required.
8. Per FCC KDB 865664 D01v01r04, variability SAR tests were performed when the measured SAR results for a frequency band were greater than or equal to 0.8 W/kg. Repeated SAR measurements are highlighted in the tables above for clarity. Please see Section 13 for variability analysis.
9. During SAR Testing for the Wireless Router conditions per FCC KDB Publication 941225 D06v02r01, the actual Portable Hotspot operation (with actual simultaneous transmission of a transmitter with WIFI) was not activated (See Section 6.7 for more details).

GSM Test Notes:

1. Body-Worn accessory testing is typically associated with voice operations. Therefore, GSM voice was evaluated for body-worn SAR.
2. Justification for reduced test configurations per KDB Publication 941225 D01v03r01 and October 2013 TCB Workshop Notes: The source-based frame-averaged output power was evaluated for all GPRS/EDGE slot configurations. The configuration with the highest target frame averaged output power was evaluated for hotspot SAR. When the maximum frame-averaged powers are equivalent across two or more slots (within 0.25 dB), the configuration with the most number of time slots was tested.
3. Per FCC KDB Publication 447498 D01v06, if the reported (scaled) SAR measured at the middle channel or highest output power channel for each test configuration is ≤ 0.8 W/kg then testing at the other channels is not required for such test configuration(s). When the maximum output power variation across the required test channels is $> \frac{1}{2}$ dB, instead of the middle channel, the highest output power channel was used.
4. GPRS was additionally evaluated for head and body-worn exposure conditions to address possible VoIP scenarios.

UMTS Notes:

1. UMTS mode in was tested under RMC 12.2 kbps with HSPA Inactive per KDB Publication 941225 D01v03r01. AMR and HSPA SAR was not required per the 3G Test Reduction Procedure in KDB Publication 941225 D01v03r01.
2. Per FCC KDB Publication 447498 D01v06, if the reported (scaled) SAR measured at the middle channel or highest output power channel for each test configuration is ≤ 0.8 W/kg then testing at the other channels is not required for such test configuration(s). When the maximum output power variation across the required test channels is $> \frac{1}{2}$ dB, instead of the middle channel, the highest output power channel was used.



FCC ID: ZNFH871	 PCTEST ENGINEERING LABORATORY, INC.	SAR EVALUATION REPORT	 LG	Approved by: Quality Manager
Document S/N: 1M1701180032-01-R4.ZNF	Test Dates: 01/20/17 - 01/30/17	DUT Type: Portable Handset	Page 67 of 97	

LTE Notes:

1. LTE Considerations: LTE test configurations are determined according to SAR Evaluation Considerations for LTE Devices in FCC KDB Publication 941225 D05v02r04. The general test procedures used for testing can be found in Section 8.5.4.
2. MPR is permanently implemented for this device by the manufacturer. The specific manufacturer target MPR is indicated alongside the SAR results. MPR is enabled for this device, according to 3GPP TS36.101 Section 6.2.3 – 6.2.5 under Table 6.2.3-1.
3. A-MPR was disabled for all SAR tests by setting NS=01 on the base station simulator. SAR tests were performed with the same number of RB and RB offsets transmitting on all TTI frames (maximum TTI).
4. Per KDB Publication 941225 D05Av01r02, SAR for LTE CA operations was not needed since the maximum average output power in LTE CA mode was not >0.25 dB higher than the maximum output power when downlink carrier aggregation was inactive.

WLAN/Bluetooth Notes:

1. For held-to-ear and hotspot operations, the initial test position procedures were applied. The test position with the highest extrapolated peak SAR will be used as the initial test position. When reported SAR for the initial test position is ≤ 0.4 W/kg, no additional testing for the remaining test positions was required. Otherwise, SAR is evaluated at the subsequent highest peak SAR positions until the reported SAR result is ≤ 0.8 W/kg or all test positions are measured.
2. Justification for test configurations for WLAN per KDB Publication 248227 D01v02r02 for 2.4 GHz WIFI single transmission chain operations, the highest measured maximum output power channel for DSSS was selected for SAR measurement. SAR for OFDM modes (2.4 GHz 802.11g/n) was not required due to the maximum allowed powers and the highest reported DSSS SAR. See Section 8.6.5 for more information.
3. Justification for test configurations for WLAN per KDB Publication 248227 D01v02r02 for 5 GHz WIFI single transmission chain operations, the initial test configuration was selected according to the transmission mode with the highest maximum allowed powers. Other transmission modes were not investigated since the highest reported SAR for initial test configuration adjusted by the ratio of maximum output powers is less than 1.2 W/kg. See Section 8.6.6 for more information.
4. Per KDB Publication 248227 D01v02r02, SAR for MIMO was evaluated by following the simultaneous SAR provisions from KDB Publication 447498 D01v06. Please see Section 12 for complete analysis.
5. When the maximum reported 1g averaged SAR is ≤ 0.8 W/kg, SAR testing on additional channels was not required. Otherwise, SAR for the next highest output power channel was required until the reported SAR result was ≤ 1.20 W/kg or all test channels were measured.
6. The device was configured to transmit continuously at the required data rate, channel bandwidth and signal modulation, using the highest transmission duty factor supported by the test mode tools. The reported SAR was scaled to the 100% transmission duty factor to determine compliance. Procedures used to measure the duty factor are identical to that in the associated EMC test reports.
7. Bluetooth SAR was measured with the device connected to a call box with hopping disabled with DH5 operation. Per October 2016 TCB Workshop Notes, the reported SAR was scaled to the 100% transmission duty factor to determine compliance. See Section 9.5 for the time-domain plot and calculation for the duty factor of the device.

FCC ID: ZNFH871	 SAR EVALUATION REPORT 		Approved by: Quality Manager
Document S/N: 1M1701180032-01-R4.ZNF	Test Dates: 01/20/17 - 01/30/17	DUT Type: Portable Handset	Page 68 of 97

12 FCC MULTI-TX AND ANTENNA SAR CONSIDERATIONS

12.1 Introduction

The following procedures adopted from FCC KDB Publication 447498 D01v06 are applicable to devices with built-in unlicensed transmitters such as 802.11 and Bluetooth devices which may simultaneously transmit with the licensed transmitter.

12.2 Simultaneous Transmission Procedures



This device contains transmitters that may operate simultaneously. Therefore simultaneous transmission analysis is required. Per FCC KDB Publication 447498 D01v06 4.3.2 and IEEE 1528-2013 Section 6.3.4.1.2, simultaneous transmission SAR test exclusion may be applied when the sum of the 1-g SAR for all the simultaneous transmitting antennas in a specific a physical test configuration is ≤ 1.6 W/kg. The different test positions in an exposure condition may be considered collectively to determine SAR test exclusion according to the sum of 1-g or 10-g SAR.

12.3 Head SAR Simultaneous Transmission Analysis

Table 12-1
Simultaneous Transmission Scenario with 2.4 GHz WLAN (Held to Ear)

Exposure Condition	Mode	2G/3G/4G SAR (W/kg)	2.4 GHz WLAN Primary Antenna SAR (W/kg)	2.4 GHz WLAN Secondary Antenna SAR (W/kg)	Σ SAR (W/kg)		
		1	2	3	1+2	1+3	1+2+3
Head SAR	GSM/GPRS 850	0.376	0.617	0.697	0.993	1.073	See Table Below
	UMTS 850	0.063	0.617	0.697	0.680	0.760	1.377
	UMTS 1750	0.162	0.617	0.697	0.779	0.859	1.476
	GSM/GPRS 1900	0.146	0.617	0.697	0.763	0.843	1.460
	UMTS 1900	0.225	0.617	0.697	0.842	0.922	1.539
	LTE Band 12	0.186	0.617	0.697	0.803	0.883	1.500
	LTE Band 13	0.124	0.617	0.697	0.741	0.821	1.438
	LTE Band 5 (Cell)	0.238	0.617	0.697	0.855	0.935	1.552
	LTE Band 66 (AWS)	0.228	0.617	0.697	0.845	0.925	1.542
	LTE Band 25 (PCS)	0.209	0.617	0.697	0.826	0.906	1.523
	LTE Band 30	0.094	0.617	0.697	0.711	0.791	1.408
LTE Band 7	0.079	0.617	0.697	0.696	0.776	1.393	

Simult Tx	Configuration	GPRS 850 SAR (W/kg)	2.4 GHz WLAN Primary Antenna SAR (W/kg)	2.4 GHz WLAN Secondary Antenna SAR (W/kg)	Σ SAR (W/kg)		
		1	2	3	1+2	1+3	1+2+3
Head SAR	Right Cheek	0.272	0.617	0.697	0.889	0.969	1.586
	Right Tilt	0.166	0.165	0.593	0.331	0.759	0.924
	Left Cheek	0.376	0.133	0.541	0.509	0.917	1.050
	Left Tilt	0.155	0.617*	0.697*	0.772	0.852	1.469

FCC ID: ZNFH871	 PCTEST ENGINEERING LABORATORY, INC.	SAR EVALUATION REPORT		Approved by: Quality Manager
Document S/N: 1M1701180032-01-R4.ZNF	Test Dates: 01/20/17 - 01/30/17	DUT Type: Portable Handset	Page 69 of 97	



**Table 12-2
Simultaneous Transmission Scenario with 5 GHz WLAN (Held to Ear)**

Exposure Condition	Mode	2G/3G/4G SAR (W/kg)	5 GHz WLAN Primary Antenna SAR (W/kg)	5 GHz WLAN Secondary Antenna SAR (W/kg)	Σ SAR (W/kg)		
		1	2	3	1+2	1+3	1+2+3
Head SAR	GSM/GPRS 850	0.376	0.122	0.652	0.498	1.028	1.150
	UMTS 850	0.063	0.122	0.652	0.185	0.715	0.837
	UMTS 1750	0.162	0.122	0.652	0.284	0.814	0.936
	GSM/GPRS 1900	0.146	0.122	0.652	0.268	0.798	0.920
	UMTS 1900	0.225	0.122	0.652	0.347	0.877	0.999
	LTE Band 12	0.186	0.122	0.652	0.308	0.838	0.960
	LTE Band 13	0.124	0.122	0.652	0.246	0.776	0.898
	LTE Band 5 (Cell)	0.238	0.122	0.652	0.360	0.890	1.012
	LTE Band 66 (AWS)	0.228	0.122	0.652	0.350	0.880	1.002
	LTE Band 25 (PCS)	0.209	0.122	0.652	0.331	0.861	0.983
	LTE Band 30	0.094	0.122	0.652	0.216	0.746	0.868
LTE Band 7	0.079	0.122	0.652	0.201	0.731	0.853	

**Table 12-3
Simultaneous Transmission Scenario with 2.4 GHz Primary Antenna and 5 GHz Secondary Antenna WLAN (Held to Ear)**

Exposure Condition	Mode	2G/3G/4G SAR (W/kg)	2.4 GHz WLAN Primary Antenna SAR (W/kg)	5 GHz WLAN Secondary Antenna SAR (W/kg)	Σ SAR (W/kg)		
		1	2	3	1+2	1+3	1+2+3
Head SAR	GSM/GPRS 850	0.376	0.617	0.652	0.993	1.028	See Table Below
	UMTS 850	0.063	0.617	0.652	0.680	0.715	1.332
	UMTS 1750	0.162	0.617	0.652	0.779	0.814	1.431
	GSM/GPRS 1900	0.146	0.617	0.652	0.763	0.798	1.415
	UMTS 1900	0.225	0.617	0.652	0.842	0.877	1.494
	LTE Band 12	0.186	0.617	0.652	0.803	0.838	1.455
	LTE Band 13	0.124	0.617	0.652	0.741	0.776	1.393
	LTE Band 5 (Cell)	0.238	0.617	0.652	0.855	0.890	1.507
	LTE Band 66 (AWS)	0.228	0.617	0.652	0.845	0.880	1.497
	LTE Band 25 (PCS)	0.209	0.617	0.652	0.826	0.861	1.478
	LTE Band 30	0.094	0.617	0.652	0.711	0.746	1.363
LTE Band 7	0.079	0.617	0.652	0.696	0.731	1.348	

Simult Tx	Configuration	GPRS 850 SAR (W/kg)	2.4 GHz WLAN Primary Antenna SAR (W/kg)	5 GHz WLAN Secondary Antenna SAR (W/kg)	Σ SAR (W/kg)		
		1	2	3	1+2	1+3	1+2+3
Head SAR	Right Cheek	0.272	0.617	0.652	0.889	0.924	1.541
	Right Tilt	0.166	0.165	0.590	0.331	0.756	0.921
	Left Cheek	0.376	0.133	0.652*	0.509	1.028	1.161
	Left Tilt	0.155	0.617*	0.652*	0.772	0.807	1.424



FCC ID: ZNFH871		SAR EVALUATION REPORT		Approved by: Quality Manager
Document S/N: 1M1701180032-01-R4.ZNF	Test Dates: 01/20/17 - 01/30/17	DUT Type: Portable Handset	Page 70 of 97	

**Table 12-4
Simultaneous Transmission Scenario with 2.4 GHz Secondary Antenna and 5 GHz Primary Antenna
WLAN (Held to Ear)**

Exposure Condition	Mode	2G/3G/4G SAR (W/kg)	2.4 GHz WLAN Secondary Antenna SAR (W/kg)	5 GHz WLAN Primary Antenna SAR (W/kg)	Σ SAR (W/kg)		
		1	2	3	1+2	1+3	1+2+3
Head SAR	GSM/GPRS 850	0.376	0.697	0.122	1.073	0.498	1.195
	UMTS 850	0.063	0.697	0.122	0.760	0.185	0.882
	UMTS 1750	0.162	0.697	0.122	0.859	0.284	0.981
	GSM/GPRS 1900	0.146	0.697	0.122	0.843	0.268	0.965
	UMTS 1900	0.225	0.697	0.122	0.922	0.347	1.044
	LTE Band 12	0.186	0.697	0.122	0.883	0.308	1.005
	LTE Band 13	0.124	0.697	0.122	0.821	0.246	0.943
	LTE Band 5 (Cell)	0.238	0.697	0.122	0.935	0.360	1.057
	LTE Band 66 (AWS)	0.228	0.697	0.122	0.925	0.350	1.047
	LTE Band 25 (PCS)	0.209	0.697	0.122	0.906	0.331	1.028
	LTE Band 30	0.094	0.697	0.122	0.791	0.216	0.913
LTE Band 7	0.079	0.697	0.122	0.776	0.201	0.898	

Notes:

1: (*) For test positions that were not required to be evaluated for WLAN SAR per FCC KDB Publication 248227, the worst case WLAN head SAR result was used for simultaneous transmission analysis.

FCC ID: ZNFH871	 PCTEST <small>ENGINEERING LABORATORY, INC.</small>	SAR EVALUATION REPORT		Approved by: Quality Manager
Document S/N: 1M1701180032-01-R4.ZNF	Test Dates: 01/20/17 - 01/30/17	DUT Type: Portable Handset	Page 71 of 97	

12.4 Body-Worn Simultaneous Transmission Analysis

Table 12-5
Simultaneous Transmission Scenario with 2.4 GHz WLAN (Body-Worn at 1.0 cm)

Exposure Condition	Mode	2G/3G/4G SAR (W/kg)	2.4 GHz WLAN Primary Antenna SAR (W/kg)	2.4 GHz WLAN Secondary Antenna SAR (W/kg)	Σ SAR (W/kg)			SPLSR		
		1	2	3	1+2	1+3	1+2+3	1+2	1+3	2+3
Body-Worn	GSM/GPRS 850	0.989	0.306	0.416	1.295	1.405	See Note 1	0.01	0.01	0.02
	UMTS 850	0.257	0.306	0.416	0.563	0.673	0.979	N/A	N/A	N/A
	UMTS 1750	0.958	0.306	0.416	1.264	1.374	See Note 1	0.01	0.01	0.02
	GSM/GPRS 1900	0.316	0.306	0.416	0.622	0.732	1.038	N/A	N/A	N/A
	UMTS 1900	0.789	0.306	0.416	1.095	1.205	1.511	N/A	N/A	N/A
	LTE Band 12	0.688	0.306	0.416	0.994	1.104	1.410	N/A	N/A	N/A
	LTE Band 13	0.474	0.306	0.416	0.780	0.890	1.196	N/A	N/A	N/A
	LTE Band 5 (Cell)	0.495	0.306	0.416	0.801	0.911	1.217	N/A	N/A	N/A
	LTE Band 66 (AWS)	1.110	0.306	0.416	1.416	1.526	See Note 1	0.02	0.01	0.02
	LTE Band 25 (PCS)	0.979	0.306	0.416	1.285	1.395	See Note 1	0.01	0.01	0.02
	LTE Band 30	1.166	0.306	0.416	1.472	1.582	See Note 1	0.01	0.01	0.02
LTE Band 7	0.317	0.306	0.416	0.623	0.733	1.039	N/A	N/A	N/A	

Table 12-6
Simultaneous Transmission Scenario with 5 GHz WLAN (Body-Worn at 1.0 cm)

Exposure Condition	Mode	2G/3G/4G SAR (W/kg)	5 GHz WLAN Primary Antenna SAR (W/kg)	5 GHz WLAN Secondary Antenna SAR (W/kg)	Σ SAR (W/kg)			SPLSR		
		1	2	3	1+2	1+3	1+2+3	1+2	1+3	2+3
Body-Worn	GSM/GPRS 850	0.989	0.500	0.364	1.489	1.353	See Note 1	0.02	0.01	0.03
	UMTS 850	0.257	0.500	0.364	0.757	0.621	1.121	N/A	N/A	N/A
	UMTS 1750	0.958	0.500	0.364	1.458	1.322	See Note 1	0.02	0.01	0.03
	GSM/GPRS 1900	0.316	0.500	0.364	0.816	0.680	1.180	N/A	N/A	N/A
	UMTS 1900	0.789	0.500	0.364	1.289	1.153	See Note 1	0.01	0.01	0.03
	LTE Band 12	0.688	0.500	0.364	1.188	1.052	1.552	N/A	N/A	N/A
	LTE Band 13	0.474	0.500	0.364	0.974	0.838	1.338	N/A	N/A	N/A
	LTE Band 5 (Cell)	0.495	0.500	0.364	0.995	0.859	1.359	N/A	N/A	N/A
	LTE Band 66 (AWS)	1.110	0.500	0.364	See Note 1	1.474	See Note 1	0.02	0.01	0.03
	LTE Band 25 (PCS)	0.979	0.500	0.364	1.479	1.343	See Note 1	0.02	0.01	0.03
	LTE Band 30	1.166	0.500	0.364	See Note 1	1.530	See Note 1	0.02	0.01	0.03
LTE Band 7	0.317	0.500	0.364	0.817	0.681	1.181	N/A	N/A	N/A	



FCC ID: ZNFH871	 PCTEST ENGINEERING LABORATORY, INC.	SAR EVALUATION REPORT		Approved by: Quality Manager
Document S/N: 1M1701180032-01-R4.ZNF	Test Dates: 01/20/17 - 01/30/17	DUT Type: Portable Handset	Page 72 of 97	

Table 12-7
Simultaneous Transmission Scenario with 2.4 GHz Primary Antenna and 5 GHz Secondary Antenna
WLAN (Body-Worn at 1.0 cm)

Exposure Condition	Mode	2G/3G/4G SAR (W/kg)	2.4 GHz WLAN Primary Antenna SAR (W/kg)	5 GHz WLAN Secondary Antenna SAR (W/kg)	Σ SAR (W/kg)			SPLSR		
		1	2	3	1+2	1+3	1+2+3	1+2	1+3	2+3
Body-Worn	GSM/GPRS 850	0.989	0.306	0.364	1.295	1.353	See Note 1	0.01	0.01	0.02
	UMTS 850	0.257	0.306	0.364	0.563	0.621	0.927	N/A	N/A	N/A
	UMTS 1750	0.958	0.306	0.364	1.264	1.322	See Note 1	0.01	0.01	0.02
	GSM/GPRS 1900	0.316	0.306	0.364	0.622	0.680	0.986	N/A	N/A	N/A
	UMTS 1900	0.789	0.306	0.364	1.095	1.153	1.459	N/A	N/A	N/A
	LTE Band 12	0.688	0.306	0.364	0.994	1.052	1.358	N/A	N/A	N/A
	LTE Band 13	0.474	0.306	0.364	0.780	0.838	1.144	N/A	N/A	N/A
	LTE Band 5 (Cell)	0.495	0.306	0.364	0.801	0.859	1.165	N/A	N/A	N/A
	LTE Band 66 (AWS)	1.110	0.306	0.364	1.416	1.474	See Note 1	0.02	0.01	0.02
	LTE Band 25 (PCS)	0.979	0.306	0.364	1.285	1.343	See Note 1	0.01	0.01	0.02
	LTE Band 30	1.166	0.306	0.364	1.472	1.530	See Note 1	0.01	0.01	0.02
LTE Band 7	0.317	0.306	0.364	0.623	0.681	0.987	N/A	N/A	N/A	

Table 12-8
Simultaneous Transmission Scenario with 2.4 GHz Secondary Antenna and 5 GHz Primary Antenna
WLAN (Body-Worn at 1.0 cm)

Exposure Condition	Mode	2G/3G/4G SAR (W/kg)	2.4 GHz WLAN Secondary Antenna SAR (W/kg)	5 GHz WLAN Primary Antenna SAR (W/kg)	Σ SAR (W/kg)			SPLSR		
		1	2	3	1+2	1+3	1+2+3	1+2	1+3	2+3
Body-Worn	GSM/GPRS 850	0.989	0.416	0.500	1.405	1.489	See Note 1	0.01	0.02	0.02
	UMTS 850	0.257	0.416	0.500	0.673	0.757	1.173	N/A	N/A	N/A
	UMTS 1750	0.958	0.416	0.500	1.374	1.458	See Note 1	0.01	0.02	0.02
	GSM/GPRS 1900	0.316	0.416	0.500	0.732	0.816	1.232	N/A	N/A	N/A
	UMTS 1900	0.789	0.416	0.500	1.205	1.289	See Note 1	0.01	0.01	0.02
	LTE Band 12	0.688	0.416	0.500	1.104	1.188	See Note 1	0.01	0.01	0.02
	LTE Band 13	0.474	0.416	0.500	0.890	0.974	1.390	N/A	N/A	N/A
	LTE Band 5 (Cell)	0.495	0.416	0.500	0.911	0.995	1.411	N/A	N/A	N/A
	LTE Band 66 (AWS)	1.110	0.416	0.500	1.526	See Note 1	See Note 1	0.01	0.02	0.02
	LTE Band 25 (PCS)	0.979	0.416	0.500	1.395	1.479	See Note 1	0.01	0.02	0.02
	LTE Band 30	1.166	0.416	0.500	1.582	See Note 1	See Note 1	0.01	0.02	0.02
LTE Band 7	0.317	0.416	0.500	0.733	0.817	1.233	N/A	N/A	N/A	





FCC ID: ZNFH871		SAR EVALUATION REPORT		Approved by: Quality Manager
Document S/N: 1M1701180032-01-R4.ZNF	Test Dates: 01/20/17 - 01/30/17	DUT Type: Portable Handset	Page 73 of 97	

Table 12-9
Simultaneous Transmission Scenario with Bluetooth (Body-Worn at 1.0 cm)

Exposure Condition	Mode	2G/3G/4G SAR (W/kg)	Bluetooth SAR (W/kg)	Σ SAR (W/kg)
		1	2	1+2
Body-Worn	GSM/GPRS 850	0.989	0.105	1.094
	UMTS 850	0.257	0.105	0.362
	UMTS 1750	0.958	0.105	1.063
	GSM/GPRS 1900	0.316	0.105	0.421
	UMTS 1900	0.789	0.105	0.894
	LTE Band 12	0.688	0.105	0.793
	LTE Band 13	0.474	0.105	0.579
	LTE Band 5 (Cell)	0.495	0.105	0.600
	LTE Band 66 (AWS)	1.110	0.105	1.215
	LTE Band 25 (PCS)	0.979	0.105	1.084
	LTE Band 30	1.166	0.105	1.271
	LTE Band 7	0.317	0.105	0.422

Notes:

1: No evaluation was performed to determine the aggregate 1g SAR for these configurations as the SPLS ratio between the antenna pairs was not greater than 0.04 per FCC KDB 447498 D01v05. See Section 12.6 for detailed SPLS ratio analysis.

FCC ID: ZNFH871		SAR EVALUATION REPORT		Approved by: Quality Manager
Document S/N: 1M1701180032-01-R4.ZNF	Test Dates: 01/20/17 - 01/30/17	DUT Type: Portable Handset	Page 74 of 97	



12.5 Hotspot SAR Simultaneous Transmission Analysis

Per FCC KDB Publication 941225 D06v02r01, the devices edges with antennas more than 2.5 cm from edge are not required to be evaluated for SAR (“-”).

Table 12-10
Simultaneous Transmission Scenario with 2.4 GHz WLAN (Hotspot at 1.0 cm)

Exposure Condition	Mode	2G/3G/4G SAR (W/kg)	2.4 GHz WLAN Primary Antenna SAR (W/kg)	2.4 GHz WLAN Secondary Antenna SAR (W/kg)	Σ SAR (W/kg)		
		1	2	3	1+2	1+3	1+2+3
Hotspot SAR	GPRS 850	1.060	0.337	0.416	1.397	1.476	See Table Below
	UMTS 850	0.257	0.337	0.416	0.594	0.673	1.010
	UMTS 1750	0.958	0.337	0.416	1.295	1.374	See Table Below
	GPRS 1900	0.406	0.337	0.416	0.743	0.822	1.159
	UMTS 1900	0.789	0.337	0.416	1.126	1.205	1.542
	LTE Band 12	0.742	0.337	0.416	1.079	1.158	1.495
	LTE Band 13	0.474	0.337	0.416	0.811	0.890	1.227
	LTE Band 5 (Cell)	0.497	0.337	0.416	0.834	0.913	1.250
	LTE Band 66 (AWS)	1.110	0.337	0.416	1.447	1.526	See Table Below
	LTE Band 25 (PCS)	1.190	0.337	0.416	1.527	See Table Below	See Table Below
	LTE Band 30	1.166	0.337	0.416	1.503	1.582	See Table Below
	LTE Band 7	0.447	0.337	0.416	0.784	0.863	1.200

Simult Tx	Configuration	GPRS 850 SAR (W/kg)	2.4 GHz WLAN Primary Antenna SAR (W/kg)	2.4 GHz WLAN Secondary Antenna SAR (W/kg)	Σ SAR (W/kg)	SPLSR		
		1	2	3	1+2+3	1+2	1+3	2+3
Hotspot SAR	Back	0.989	0.306	0.416	See Note 1	0.01	0.01	0.02
	Front	1.060	0.326	0.399	See Note 1	0.01	0.01	0.01
	Top	-	0.337*	0.416*	0.753	N/A	N/A	N/A
	Bottom	0.529	-	-	0.529	N/A	N/A	N/A
	Right	0.229	-	-	0.229	N/A	N/A	N/A
	Left	0.499	0.337	0.416*	1.252	N/A	N/A	N/A
Simult Tx	Configuration	UMTS 1750 SAR (W/kg)	2.4 GHz WLAN Primary Antenna SAR (W/kg)	2.4 GHz WLAN Secondary Antenna SAR (W/kg)	Σ SAR (W/kg)	SPLSR		
		1	2	3	1+2+3	1+2	1+3	2+3
Hotspot SAR	Back	0.958	0.306	0.416	See Note 1	0.01	0.01	0.02
	Front	0.657	0.326	0.399	1.382	N/A	N/A	N/A
	Top	-	0.337*	0.416*	0.753	N/A	N/A	N/A
	Bottom	0.386	-	-	0.386	N/A	N/A	N/A
	Right	-	-	-	0.000	N/A	N/A	N/A
	Left	0.256	0.337	0.416*	1.009	N/A	N/A	N/A
Simult Tx	Configuration	LTE Band 66 (AWS) SAR (W/kg)	2.4 GHz WLAN Primary Antenna SAR (W/kg)	2.4 GHz WLAN Secondary Antenna SAR (W/kg)	Σ SAR (W/kg)	SPLSR		
		1	2	3	1+2+3	1+2	1+3	2+3
Hotspot SAR	Back	1.110	0.306	0.416	See Note 1	0.02	0.01	0.02
	Front	1.100	0.326	0.399	See Note 1	0.01	0.01	0.01
	Top	-	0.337*	0.416*	0.753	N/A	N/A	N/A
	Bottom	1.042	-	-	1.042	N/A	N/A	N/A
	Right	-	-	-	0.000	N/A	N/A	N/A
	Left	0.450	0.337	0.416*	1.203	N/A	N/A	N/A



FCC ID: ZNFH871		SAR EVALUATION REPORT		Approved by: Quality Manager
Document S/N: 1M1701180032-01-R4.ZNF	Test Dates: 01/20/17 - 01/30/17	DUT Type: Portable Handset		Page 75 of 97

Simult Tx	Configuration	LTE Band 25 (PCS) SAR (W/kg)	2.4 GHz WLAN Primary Antenna SAR (W/kg)	2.4 GHz WLAN Secondary Antenna SAR (W/kg)	Σ SAR (W/kg)	SPLSR		
		1	2	3		1+2+3	1+2	1+3
Hotspot SAR	Back	0.979	0.306	0.416	See Note 1	0.01	0.01	0.02
	Front	0.823	0.326	0.399	1.548	N/A	N/A	N/A
	Top	-	0.337*	0.416*	0.753	N/A	N/A	N/A
	Bottom	1.190	-	-	1.190	N/A	N/A	N/A
	Right	-	-	-	0.000	N/A	N/A	N/A
	Left	0.393	0.337	0.416*	1.146	N/A	N/A	N/A
Simult Tx	Configuration	LTE Band 30 SAR (W/kg)	2.4 GHz WLAN Primary Antenna SAR (W/kg)	2.4 GHz WLAN Secondary Antenna SAR (W/kg)	Σ SAR (W/kg)	SPLSR		
		1	2	3		1+2+3	1+2	1+3
Hotspot SAR	Back	1.166	0.306	0.416	See Note 1	0.01	0.01	0.02
	Front	0.277	0.326	0.399	1.002	N/A	N/A	N/A
	Top	-	0.337*	0.416*	0.753	N/A	N/A	N/A
	Bottom	0.352	-	-	0.352	N/A	N/A	N/A
	Right	0.144	-	-	0.144	N/A	N/A	N/A
	Left	0.027	0.337	0.416*	0.780	N/A	N/A	N/A

Table 12-11
Simultaneous Transmission Scenario with 5 GHz WLAN (Hotspot at 1.0 cm)

Exposure Condition	Mode	2G/3G/4G SAR (W/kg)	5 GHz WLAN Primary Antenna SAR (W/kg)	5 GHz WLAN Secondary Antenna SAR (W/kg)	Σ SAR (W/kg)		
		1	2	3	1+2	1+3	1+2+3
Hotspot SAR	GPRS 850	1.060	0.500	0.329	1.560	1.389	See Table Below
	UMTS 850	0.257	0.500	0.329	0.757	0.586	1.086
	UMTS 1750	0.958	0.500	0.329	1.458	1.287	See Table Below
	GPRS 1900	0.406	0.500	0.329	0.906	0.735	1.235
	UMTS 1900	0.789	0.500	0.329	1.289	1.118	See Table Below
	LTE Band 12	0.742	0.500	0.329	1.242	1.071	1.571
	LTE Band 13	0.474	0.500	0.329	0.974	0.803	1.303
	LTE Band 5 (Cell)	0.497	0.500	0.329	0.997	0.826	1.326
	LTE Band 66 (AWS)	1.110	0.500	0.329	See Table Below	1.439	See Table Below
	LTE Band 25 (PCS)	1.190	0.500	0.329	See Table Below	1.519	See Table Below
	LTE Band 30	1.166	0.500	0.329	See Table Below	1.495	See Table Below
LTE Band 7	0.447	0.500	0.329	0.947	0.776	1.276	

Simult Tx	Configuration	GPRS 850 SAR (W/kg)	5 GHz WLAN Primary Antenna SAR (W/kg)	5 GHz WLAN Secondary Antenna SAR (W/kg)	Σ SAR (W/kg)	SPLSR		
		1	2	3		1+2+3	1+2	1+3
Hotspot SAR	Back	0.989	0.500	0.329	See Note 1	0.02	0.01	0.04
	Front	1.060	0.047	0.156	1.263	N/A	N/A	N/A
	Top	-	0.500*	0.055	0.555	N/A	N/A	N/A
	Bottom	0.529	-	-	0.529	N/A	N/A	N/A
	Right	0.229	-	-	0.229	N/A	N/A	N/A
	Left	0.499	0.200	0.329*	1.028	N/A	N/A	N/A
Simult Tx	Configuration	UMTS 1750 SAR (W/kg)	5 GHz WLAN Primary Antenna SAR (W/kg)	5 GHz WLAN Secondary Antenna SAR (W/kg)	Σ SAR (W/kg)	SPLSR		
		1	2	3		1+2+3	1+2	1+3
Hotspot SAR	Back	0.958	0.500	0.329	See Note 1	0.02	0.01	0.04
	Front	0.657	0.047	0.156	0.860	N/A	N/A	N/A
	Top	-	0.500*	0.055	0.555	N/A	N/A	N/A
	Bottom	0.386	-	-	0.386	N/A	N/A	N/A
	Right	-	-	-	0.000	N/A	N/A	N/A
	Left	0.256	0.200	0.329*	0.785	N/A	N/A	N/A

FCC ID: ZNFH871	 PCTEST ENGINEERING LABORATORY, INC.	SAR EVALUATION REPORT		Approved by: Quality Manager
Document S/N: 1M1701180032-01-R4.ZNF	Test Dates: 01/20/17 - 01/30/17	DUT Type: Portable Handset		Page 76 of 97

Simult Tx	Configuration	UMTS 1900 SAR (W/kg)	5 GHz WLAN Primary Antenna SAR (W/kg)	5 GHz WLAN Secondary Antenna SAR (W/kg)	Σ SAR (W/kg)	SPLSR		
		1	2	3		1+2+3	1+2	1+3
Hotspot SAR	Back	0.789	0.500	0.329	See Note 1	0.01	0.01	0.04
	Front	0.718	0.047	0.156	0.921	N/A	N/A	N/A
	Top	-	0.500*	0.055	0.555	N/A	N/A	N/A
	Bottom	0.736	-	-	0.736	N/A	N/A	N/A
	Right	-	-	-	0.000	N/A	N/A	N/A
	Left	0.408	0.200	0.329*	0.937	N/A	N/A	N/A
Simult Tx	Configuration	LTE Band 66 (AWS) SAR (W/kg)	5 GHz WLAN Primary Antenna SAR (W/kg)	5 GHz WLAN Secondary Antenna SAR (W/kg)	Σ SAR (W/kg)	SPLSR		
		1	2	3		1+2+3	1+2	1+3
Hotspot SAR	Back	1.110	0.500	0.329	See Note 1	0.02	0.01	0.04
	Front	1.100	0.047	0.156	1.303	N/A	N/A	N/A
	Top	-	0.500*	0.055	0.555	N/A	N/A	N/A
	Bottom	1.042	-	-	1.042	N/A	N/A	N/A
	Right	-	-	-	0.000	N/A	N/A	N/A
	Left	0.450	0.200	0.329*	0.979	N/A	N/A	N/A
Simult Tx	Configuration	LTE Band 25 (PCS) SAR (W/kg)	5 GHz WLAN Primary Antenna SAR (W/kg)	5 GHz WLAN Secondary Antenna SAR (W/kg)	Σ SAR (W/kg)	SPLSR		
		1	2	3		1+2+3	1+2	1+3
Hotspot SAR	Back	0.979	0.500	0.329	See Note 1	0.02	0.01	0.04
	Front	0.823	0.047	0.156	1.026	N/A	N/A	N/A
	Top	-	0.500*	0.055	0.555	N/A	N/A	N/A
	Bottom	1.190	-	-	1.190	N/A	N/A	N/A
	Right	-	-	-	0.000	N/A	N/A	N/A
	Left	0.393	0.200	0.329*	0.922	N/A	N/A	N/A
Simult Tx	Configuration	LTE Band 30 SAR (W/kg)	5 GHz WLAN Primary Antenna SAR (W/kg)	5 GHz WLAN Secondary Antenna SAR (W/kg)	Σ SAR (W/kg)	SPLSR		
		1	2	3		1+2+3	1+2	1+3
Hotspot SAR	Back	1.166	0.500	0.329	See Note 1	0.02	0.01	0.04
	Front	0.277	0.047	0.156	0.480	N/A	N/A	N/A
	Top	-	0.500*	0.055	0.555	N/A	N/A	N/A
	Bottom	0.352	-	-	0.352	N/A	N/A	N/A
	Right	0.144	-	-	0.144	N/A	N/A	N/A
	Left	0.027	0.200	0.329*	0.556	N/A	N/A	N/A



FCC ID: ZNFH871		SAR EVALUATION REPORT		Approved by: Quality Manager
Document S/N: 1M1701180032-01-R4.ZNF	Test Dates: 01/20/17 - 01/30/17	DUT Type: Portable Handset		Page 77 of 97



Table 12-12
Simultaneous Transmission Scenario with 2.4 GHz Primary Antenna and 5 GHz Secondary Antenna
WLAN (Hotspot at 1.0 cm)

Exposure Condition	Mode	2G/3G/4G SAR (W/kg)	2.4 GHz WLAN Primary Antenna SAR (W/kg)	5 GHz WLAN Secondary Antenna SAR (W/kg)	Σ SAR (W/kg)		
		1	2	3	1+2	1+3	1+2+3
Hotspot SAR	GPRS 850	1.060	0.337	0.329	1.397	1.389	See Table Below
	UMTS 850	0.257	0.337	0.329	0.594	0.586	0.923
	UMTS 1750	0.958	0.337	0.329	1.295	1.287	See Table Below
	GPRS 1900	0.406	0.337	0.329	0.743	0.735	1.072
	UMTS 1900	0.789	0.337	0.329	1.126	1.118	1.455
	LTE Band 12	0.742	0.337	0.329	1.079	1.071	1.408
	LTE Band 13	0.474	0.337	0.329	0.811	0.803	1.140
	LTE Band 5 (Cell)	0.497	0.337	0.329	0.834	0.826	1.163
	LTE Band 66 (AWS)	1.110	0.337	0.329	1.447	1.439	See Table Below
	LTE Band 25 (PCS)	1.190	0.337	0.329	1.527	1.519	See Table Below
	LTE Band 30	1.166	0.337	0.329	1.503	1.495	See Table Below
	LTE Band 7	0.447	0.337	0.329	0.784	0.776	1.113

Simult Tx	Configuration	GPRS 850 SAR (W/kg)	2.4 GHz WLAN Primary Antenna SAR (W/kg)	5 GHz WLAN Secondary Antenna SAR (W/kg)	Σ SAR (W/kg)	SPLSR		
		1	2	3	1+2+3	1+2	1+3	2+3
Hotspot SAR	Back	0.989	0.306	0.329	See Note 1	0.01	0.01	0.03
	Front	1.060	0.326	0.156	1.542	N/A	N/A	N/A
	Top	-	0.337*	0.055	0.392	N/A	N/A	N/A
	Bottom	0.529	-	-	0.529	N/A	N/A	N/A
	Right	0.229	-	-	0.229	N/A	N/A	N/A
	Left	0.499	0.337	0.329*	1.165	N/A	N/A	N/A

Simult Tx	Configuration	UMTS 1750 SAR (W/kg)	2.4 GHz WLAN Primary Antenna SAR (W/kg)	5 GHz WLAN Secondary Antenna SAR (W/kg)	Σ SAR (W/kg)
		1	2	3	1+2+3
Hotspot SAR	Back	0.958	0.306	0.329	1.593
	Front	0.657	0.326	0.156	1.139
	Top	-	0.337*	0.055	0.392
	Bottom	0.386	-	-	0.386
	Right	-	-	-	0.000
	Left	0.256	0.337	0.329*	0.922

Simult Tx	Configuration	LTE Band 66 (AWS) SAR (W/kg)	2.4 GHz WLAN Primary Antenna SAR (W/kg)	5 GHz WLAN Secondary Antenna SAR (W/kg)	Σ SAR (W/kg)	SPLSR		
		1	2	3	1+2+3	1+2	1+3	2+3
Hotspot SAR	Back	1.110	0.306	0.329	See Note 1	0.02	0.01	0.03
	Front	1.100	0.326	0.156	1.582	N/A	N/A	N/A
	Top	-	0.337*	0.055	0.392	N/A	N/A	N/A
	Bottom	1.042	-	-	1.042	N/A	N/A	N/A
	Right	-	-	-	0.000	N/A	N/A	N/A
	Left	0.450	0.337	0.329*	1.116	N/A	N/A	N/A



FCC ID: ZNFH871		SAR EVALUATION REPORT		Approved by: Quality Manager
Document S/N: 1M1701180032-01-R4.ZNF	Test Dates: 01/20/17 - 01/30/17	DUT Type: Portable Handset		Page 78 of 97

Simult Tx	Configuration	LTE Band 25 (PCS) SAR (W/kg)	2.4 GHz WLAN Secondary Antenna SAR (W/kg)	5 GHz WLAN Secondary Antenna SAR (W/kg)	Σ SAR (W/kg)	SPLSR		
		1	2	3		1+2+3	1+2	1+3
Hotspot SAR	Back	0.979	0.306	0.329	See Note 1	0.01	0.01	0.03
	Front	0.823	0.326	0.156	1.305	N/A	N/A	N/A
	Top	-	0.337*	0.055	0.392	N/A	N/A	N/A
	Bottom	1.190	-	-	1.190	N/A	N/A	N/A
	Right	-	-	-	0.000	N/A	N/A	N/A
	Left	0.393	0.337	0.329*	1.059	N/A	N/A	N/A
Simult Tx	Configuration	LTE Band 30 SAR (W/kg)	2.4 GHz WLAN Primary Antenna SAR (W/kg)	5 GHz WLAN Secondary Antenna SAR (W/kg)	Σ SAR (W/kg)	SPLSR		
		1	2	3		1+2+3	1+2	1+3
Hotspot SAR	Back	1.166	0.306	0.329	See Note 1	0.01	0.01	0.03
	Front	0.277	0.326	0.156	0.759	N/A	N/A	N/A
	Top	-	0.337*	0.055	0.392	N/A	N/A	N/A
	Bottom	0.352	-	-	0.352	N/A	N/A	N/A
	Right	0.144	-	-	0.144	N/A	N/A	N/A
	Left	0.027	0.337	0.329*	0.693	N/A	N/A	N/A

**Table 12-13
Simultaneous Transmission Scenario with 2.4 GHz Secondary Antenna and 5 GHz Primary Antenna WLAN (Hotspot at 1.0 cm)**

Exposure Condition	Mode	2G/3G/4G SAR (W/kg)	2.4 GHz WLAN Secondary Antenna SAR (W/kg)	5 GHz WLAN Primary Antenna SAR (W/kg)	Σ SAR (W/kg)		
		1	2	3	1+2	1+3	1+2+3
Hotspot SAR	GPRS 850	1.060	0.416	0.500	1.476	1.560	See Table Below
	UMTS 850	0.257	0.416	0.500	0.673	0.757	1.173
	UMTS 1750	0.958	0.416	0.500	1.374	1.458	See Table Below
	GPRS 1900	0.406	0.416	0.500	0.822	0.906	1.322
	UMTS 1900	0.789	0.416	0.500	1.205	1.289	See Table Below
	LTE Band 12	0.742	0.416	0.500	1.158	1.242	See Table Below
	LTE Band 13	0.474	0.416	0.500	0.890	0.974	1.390
	LTE Band 5 (Cell)	0.497	0.416	0.500	0.913	0.997	1.413
	LTE Band 66 (AWS)	1.110	0.416	0.500	1.526	See Table Below	See Table Below
	LTE Band 25 (PCS)	1.190	0.416	0.500	See Table Below	See Table Below	See Table Below
	LTE Band 30	1.166	0.416	0.500	1.582	See Table Below	See Table Below
LTE Band 7	0.447	0.416	0.500	0.863	0.947	1.363	



Simult Tx	Configuration	GPRS 850 SAR (W/kg)	2.4 GHz WLAN Secondary Antenna SAR (W/kg)	5 GHz WLAN Primary Antenna SAR (W/kg)	Σ SAR (W/kg)	SPLSR		
		1	2	3		1+2+3	1+2	1+3
Hotspot SAR	Back	0.989	0.416	0.500	See Note 1	0.01	0.02	0.02
	Front	1.060	0.399	0.047	1.506	N/A	N/A	N/A
	Top	-	0.416*	0.500*	0.916	N/A	N/A	N/A
	Bottom	0.529	-	-	0.529	N/A	N/A	N/A
	Right	0.229	-	-	0.229	N/A	N/A	N/A
	Left	0.499	0.416*	0.200	1.115	N/A	N/A	N/A
Simult Tx	Configuration	UMTS 1750 SAR (W/kg)	2.4 GHz WLAN Secondary Antenna SAR (W/kg)	5 GHz WLAN Primary Antenna SAR (W/kg)	Σ SAR (W/kg)	SPLSR		
		1	2	3		1+2+3	1+2	1+3
Hotspot SAR	Back	0.958	0.416	0.500	See Note 1	0.01	0.02	0.02
	Front	0.657	0.399	0.047	1.103	N/A	N/A	N/A
	Top	-	0.416*	0.500*	0.916	N/A	N/A	N/A
	Bottom	0.386	-	-	0.386	N/A	N/A	N/A
	Right	-	-	-	0.000	N/A	N/A	N/A
	Left	0.256	0.416*	0.200	0.872	N/A	N/A	N/A

FCC ID: ZNFH871		SAR EVALUATION REPORT		Approved by: Quality Manager
Document S/N: 1M1701180032-01-R4.ZNF	Test Dates: 01/20/17 - 01/30/17	DUT Type: Portable Handset		Page 79 of 97

Simult Tx	Configuration	UMTS 1900 SAR (W/kg)	2.4 GHz WLAN Secondary Antenna SAR (W/kg)	5 GHz WLAN Primary Antenna SAR (W/kg)	Σ SAR (W/kg)	SPLSR		
		1	2	3		1+2+3	1+2	1+3
Hotspot SAR	Back	0.789	0.416	0.500	See Note 1	0.01	0.01	0.02
	Front	0.718	0.399	0.047	1.164	N/A	N/A	N/A
	Top	-	0.416*	0.500*	0.916	N/A	N/A	N/A
	Bottom	0.736	-	-	0.736	N/A	N/A	N/A
	Right	-	-	-	0.000	N/A	N/A	N/A
	Left	0.408	0.416*	0.200	1.024	N/A	N/A	N/A
Simult Tx	Configuration	LTE Band 12 SAR (W/kg)	2.4 GHz WLAN Secondary Antenna SAR (W/kg)	5 GHz WLAN Primary Antenna SAR (W/kg)	Σ SAR (W/kg)	SPLSR		
	1	2	3	1+2+3		1+2	1+3	2+3
Hotspot SAR	Back	0.688	0.416	0.500	See Note 1	0.01	0.01	0.02
	Front	0.742	0.399	0.047	1.188	N/A	N/A	N/A
	Top	-	0.416*	0.500*	0.916	N/A	N/A	N/A
	Bottom	0.426	-	-	0.426	N/A	N/A	N/A
	Right	0.294	-	-	0.294	N/A	N/A	N/A
	Left	0.264	0.416*	0.200	0.880	N/A	N/A	N/A
Simult Tx	Configuration	LTE Band 66 (AWS) SAR (W/kg)	2.4 GHz WLAN Secondary Antenna SAR (W/kg)	5 GHz WLAN Primary Antenna SAR (W/kg)	Σ SAR (W/kg)	SPLSR		
	1	2	3	1+2+3		1+2	1+3	2+3
Hotspot SAR	Back	1.110	0.416	0.500	See Note 1	0.01	0.02	0.02
	Front	1.100	0.399	0.047	1.546	N/A	N/A	N/A
	Top	-	0.416*	0.500*	0.916	N/A	N/A	N/A
	Bottom	1.042	-	-	1.042	N/A	N/A	N/A
	Right	-	-	-	0.000	N/A	N/A	N/A
	Left	0.450	0.416*	0.200	1.066	N/A	N/A	N/A
Simult Tx	Configuration	LTE Band 25 (PCS) SAR (W/kg)	2.4 GHz WLAN Secondary Antenna SAR (W/kg)	5 GHz WLAN Primary Antenna SAR (W/kg)	Σ SAR (W/kg)	SPLSR		
	1	2	3	1+2+3		1+2	1+3	2+3
Hotspot SAR	Back	0.979	0.416	0.500	See Note 1	0.01	0.02	0.02
	Front	0.823	0.399	0.047	1.269	N/A	N/A	N/A
	Top	-	0.416*	0.500*	0.916	N/A	N/A	N/A
	Bottom	1.190	-	-	1.190	N/A	N/A	N/A
	Right	-	-	-	0.000	N/A	N/A	N/A
	Left	0.393	0.416*	0.200	1.009	N/A	N/A	N/A
Simult Tx	Configuration	LTE Band 30 SAR (W/kg)	2.4 GHz WLAN Secondary Antenna SAR (W/kg)	5 GHz WLAN Primary Antenna SAR (W/kg)	Σ SAR (W/kg)	SPLSR		
	1	2	3	1+2+3		1+2	1+3	2+3
Hotspot SAR	Back	1.166	0.416	0.500	See Note 1	0.01	0.02	0.02
	Front	0.277	0.399	0.047	0.723	N/A	N/A	N/A
	Top	-	0.416*	0.500*	0.916	N/A	N/A	N/A
	Bottom	0.352	-	-	0.352	N/A	N/A	N/A
	Right	0.144	-	-	0.144	N/A	N/A	N/A
	Left	0.027	0.416*	0.200	0.643	N/A	N/A	N/A

Notes:

- 1: No evaluation was performed to determine the aggregate 1g SAR for these configurations as the SPLS ratio between the antenna pairs was not greater than 0.04 per FCC KDB 447498 D01v05. See Section 12.6 for detailed SPLS ratio analysis.
- 2: (*) For test positions that were not required to be evaluated for WLAN SAR per FCC KDB Publication 248227, the worst case WLAN hotspot SAR result was used for simultaneous transmission analysis.

FCC ID: ZNFH871		SAR EVALUATION REPORT		Approved by: Quality Manager
Document S/N: 1M1701180032-01-R4.ZNF	Test Dates: 01/20/17 - 01/30/17	DUT Type: Portable Handset		Page 80 of 97

12.6 SPLSR Evaluation and Analysis

Per FCC KDB Publication 447498 D01v06, when the sum of the standalone transmitters is more than 1.6 W/kg for 1g, the SAR sum to peak locations can be analyzed to determine SAR distribution overlaps. When the SAR peak to location ratio (shown below) for each pair of antennas is

≤ 0.04 for 1g, simultaneous SAR evaluation is not required. The distance between the transmitters was calculated using the following formula.

$$\text{Distance}_{\text{TX1-TX2}} = R_i = \sqrt{(x_1 - x_2)^2 + (y_1 - y_2)^2}$$

$$\text{SPLSR Ratio} = \frac{(SAR_1 + SAR_2)^{1.5}}{R_i}$$

12.6.1 Body-Worn SPLSR Evaluation and Analysis

Table 12-14
Peak SAR Locations for Body-Worn

Mode/Band	x (mm)	y (mm)	Reported SAR (W/kg)
2.4 GHz WLAN Primary Ant	16.60	46.80	0.306
2.4 GHz WLAN Secondary Ant	-15.80	70.80	0.416
5 GHz WLAN Primary Ant	9.00	42.00	0.5
5 GHz WLAN Secondary Ant	5.00	67.00	0.364
GPRS 850	-22.50	-46.50	0.989
UMTS 1750	-5.00	-57.00	0.958
UMTS 1900	2.00	-73.00	0.789
LTE Band 12	-44.00	-49.50	0.688
LTE Band 66 (AWS)	-14.00	-55.50	1.11
LTE Band 25 (PCS)	7.00	-64.50	0.979
LTE Band 30	-37.40	-62.40	1.166



FCC ID: ZNFH871	 PCTEST ENGINEERING LABORATORY, INC.	SAR EVALUATION REPORT	 LG	Approved by: Quality Manager
Document S/N: 1M1701180032-01-R4.ZNF	Test Dates: 01/20/17 - 01/30/17	DUT Type: Portable Handset		Page 81 of 97

Table 12-15
Body-Worn SAR Sum to Peak Location Separation Ratio Calculations

Antenna Pair		Standalone 1g SAR (W/kg)		Standalone SAR Sum (W/kg)	Peak SAR Separation Distance (mm)	SPLS Ratio	Plot Number
Ant "a"	Ant "b"	a	b	a+b	D _{ab}	(a+b) ^{1.5} /D _{ab}	
2.4 GHz WLAN Primary Ant	2.4 GHz WLAN Secondary Ant	0.306	0.416	0.722	40.32	0.02	1
GPRS 850	2.4 GHz WLAN Primary Ant	0.989	0.306	1.295	101.16	0.01	
GPRS 850	2.4 GHz WLAN Secondary Ant	0.989	0.416	1.405	117.49	0.01	
2.4 GHz WLAN Primary Ant	2.4 GHz WLAN Secondary Ant	0.306	0.416	0.722	40.32	0.02	2
UMTS 1750	2.4 GHz WLAN Primary Ant	0.958	0.306	1.264	106.02	0.01	
UMTS 1750	2.4 GHz WLAN Secondary Ant	0.958	0.416	1.374	128.26	0.01	
2.4 GHz WLAN Primary Ant	2.4 GHz WLAN Secondary Ant	0.306	0.416	0.722	40.32	0.02	3
LTE Band 66 (AWS)	2.4 GHz WLAN Primary Ant	1.11	0.306	1.416	106.78	0.02	
LTE Band 66 (AWS)	2.4 GHz WLAN Secondary Ant	1.11	0.416	1.526	126.31	0.01	
2.4 GHz WLAN Primary Ant	2.4 GHz WLAN Secondary Ant	0.306	0.416	0.722	40.32	0.02	4
LTE Band 25 (PCS)	2.4 GHz WLAN Primary Ant	0.979	0.306	1.285	111.71	0.01	
LTE Band 25 (PCS)	2.4 GHz WLAN Secondary Ant	0.979	0.416	1.395	137.21	0.01	
2.4 GHz WLAN Primary Ant	2.4 GHz WLAN Secondary Ant	0.306	0.416	0.722	40.32	0.02	5
LTE Band 30	2.4 GHz WLAN Primary Ant	1.166	0.306	1.472	121.82	0.01	
LTE Band 30	2.4 GHz WLAN Secondary Ant	1.166	0.416	1.582	134.94	0.01	
5 GHz WLAN Primary Ant	5 GHz WLAN Secondary Ant	0.5	0.364	0.864	25.32	0.03	6
GPRS 850	5 GHz WLAN Primary Ant	0.989	0.5	1.489	93.94	0.02	
GPRS 850	5 GHz WLAN Secondary Ant	0.989	0.364	1.353	116.78	0.01	
5 GHz WLAN Primary Ant	5 GHz WLAN Secondary Ant	0.5	0.364	0.864	25.32	0.03	7
UMTS 1750	5 GHz WLAN Primary Ant	0.958	0.5	1.458	99.98	0.02	
UMTS 1750	5 GHz WLAN Secondary Ant	0.958	0.364	1.322	124.40	0.01	
5 GHz WLAN Primary Ant	5 GHz WLAN Secondary Ant	0.5	0.364	0.864	25.32	0.03	8
UMTS 1900	5 GHz WLAN Primary Ant	0.789	0.5	1.289	115.21	0.01	
UMTS 1900	5 GHz WLAN Secondary Ant	0.789	0.364	1.153	140.03	0.01	
5 GHz WLAN Primary Ant	5 GHz WLAN Secondary Ant	0.5	0.364	0.864	25.32	0.03	9
LTE Band 66 (AWS)	5 GHz WLAN Primary Ant	1.11	0.5	1.610	100.18	0.02	
LTE Band 66 (AWS)	5 GHz WLAN Secondary Ant	1.11	0.364	1.474	123.96	0.01	
5 GHz WLAN Primary Ant	5 GHz WLAN Secondary Ant	0.5	0.364	0.864	25.32	0.03	10
LTE Band 25 (PCS)	5 GHz WLAN Primary Ant	0.979	0.5	1.479	106.52	0.02	
LTE Band 25 (PCS)	5 GHz WLAN Secondary Ant	0.979	0.364	1.343	131.52	0.01	
5 GHz WLAN Primary Ant	5 GHz WLAN Secondary Ant	0.5	0.364	0.864	25.32	0.03	11
LTE Band 30	5 GHz WLAN Primary Ant	1.166	0.5	1.666	114.25	0.02	
LTE Band 30	5 GHz WLAN Secondary Ant	1.166	0.364	1.530	136.17	0.01	
2.4 GHz WLAN Primary Ant	5 GHz WLAN Secondary Ant	0.306	0.364	0.670	23.29	0.02	12
GPRS 850	2.4 GHz WLAN Primary Ant	0.989	0.306	1.295	101.16	0.01	
GPRS 850	5 GHz WLAN Secondary Ant	0.989	0.364	1.353	116.78	0.01	
2.4 GHz WLAN Primary Ant	5 GHz WLAN Secondary Ant	0.306	0.364	0.670	23.29	0.02	13
UMTS 1750	2.4 GHz WLAN Primary Ant	0.958	0.306	1.264	106.02	0.01	
UMTS 1750	5 GHz WLAN Secondary Ant	0.958	0.364	1.322	124.40	0.01	
2.4 GHz WLAN Primary Ant	5 GHz WLAN Secondary Ant	0.306	0.364	0.670	23.29	0.02	14
LTE Band 66 (AWS)	2.4 GHz WLAN Primary Ant	1.11	0.306	1.416	106.78	0.02	
LTE Band 66 (AWS)	5 GHz WLAN Secondary Ant	1.11	0.364	1.474	123.96	0.01	
2.4 GHz WLAN Primary Ant	5 GHz WLAN Secondary Ant	0.306	0.364	0.670	23.29	0.02	15
LTE Band 25 (PCS)	2.4 GHz WLAN Primary Ant	0.979	0.306	1.285	111.71	0.01	
LTE Band 25 (PCS)	5 GHz WLAN Secondary Ant	0.979	0.364	1.343	131.52	0.01	
2.4 GHz WLAN Primary Ant	5 GHz WLAN Secondary Ant	0.306	0.364	0.670	23.29	0.02	16
LTE Band 30	2.4 GHz WLAN Primary Ant	1.166	0.306	1.472	121.82	0.01	
LTE Band 30	5 GHz WLAN Secondary Ant	1.166	0.364	1.530	136.17	0.01	
2.4 GHz WLAN Secondary Ant	5 GHz WLAN Primary Ant	0.416	0.5	0.916	38.01	0.02	17
GPRS 850	2.4 GHz WLAN Secondary Ant	0.989	0.416	1.405	117.49	0.01	
GPRS 850	5 GHz WLAN Primary Ant	0.989	0.5	1.489	93.94	0.02	
2.4 GHz WLAN Secondary Ant	5 GHz WLAN Primary Ant	0.416	0.5	0.916	38.01	0.02	18
UMTS 1750	2.4 GHz WLAN Secondary Ant	0.958	0.416	1.374	128.26	0.01	
UMTS 1750	5 GHz WLAN Primary Ant	0.958	0.5	1.458	99.98	0.02	
2.4 GHz WLAN Secondary Ant	5 GHz WLAN Primary Ant	0.416	0.5	0.916	38.01	0.02	19
UMTS 1900	2.4 GHz WLAN Secondary Ant	0.789	0.416	1.205	144.90	0.01	
UMTS 1900	5 GHz WLAN Primary Ant	0.789	0.5	1.289	115.21	0.01	
2.4 GHz WLAN Secondary Ant	5 GHz WLAN Primary Ant	0.416	0.5	0.916	38.01	0.02	20
LTE Band 12	2.4 GHz WLAN Secondary Ant	0.688	0.416	1.104	123.56	0.01	
LTE Band 12	5 GHz WLAN Primary Ant	0.688	0.5	1.188	105.74	0.01	
2.4 GHz WLAN Secondary Ant	5 GHz WLAN Primary Ant	0.416	0.5	0.916	38.01	0.02	21
LTE Band 66 (AWS)	2.4 GHz WLAN Secondary Ant	1.11	0.416	1.526	126.31	0.01	
LTE Band 66 (AWS)	5 GHz WLAN Primary Ant	1.11	0.5	1.610	100.18	0.02	
2.4 GHz WLAN Secondary Ant	5 GHz WLAN Primary Ant	0.416	0.5	0.916	38.01	0.02	22
LTE Band 25 (PCS)	2.4 GHz WLAN Secondary Ant	0.979	0.416	1.395	137.21	0.01	
LTE Band 25 (PCS)	5 GHz WLAN Primary Ant	0.979	0.5	1.479	106.52	0.02	
2.4 GHz WLAN Secondary Ant	5 GHz WLAN Primary Ant	0.416	0.5	0.916	38.01	0.02	23
LTE Band 30	2.4 GHz WLAN Secondary Ant	1.166	0.416	1.582	134.94	0.01	
LTE Band 30	5 GHz WLAN Primary Ant	1.166	0.5	1.666	114.25	0.02	







FCC ID: ZNFH871		SAR EVALUATION REPORT		Approved by: Quality Manager
Document S/N: 1M1701180032-01-R4.ZNF	Test Dates: 01/20/17 - 01/30/17	DUT Type: Portable Handset		Page 82 of 97

Table 12-16
Body-Worn SAR Sum to Peak Location Separation Ratio Plots



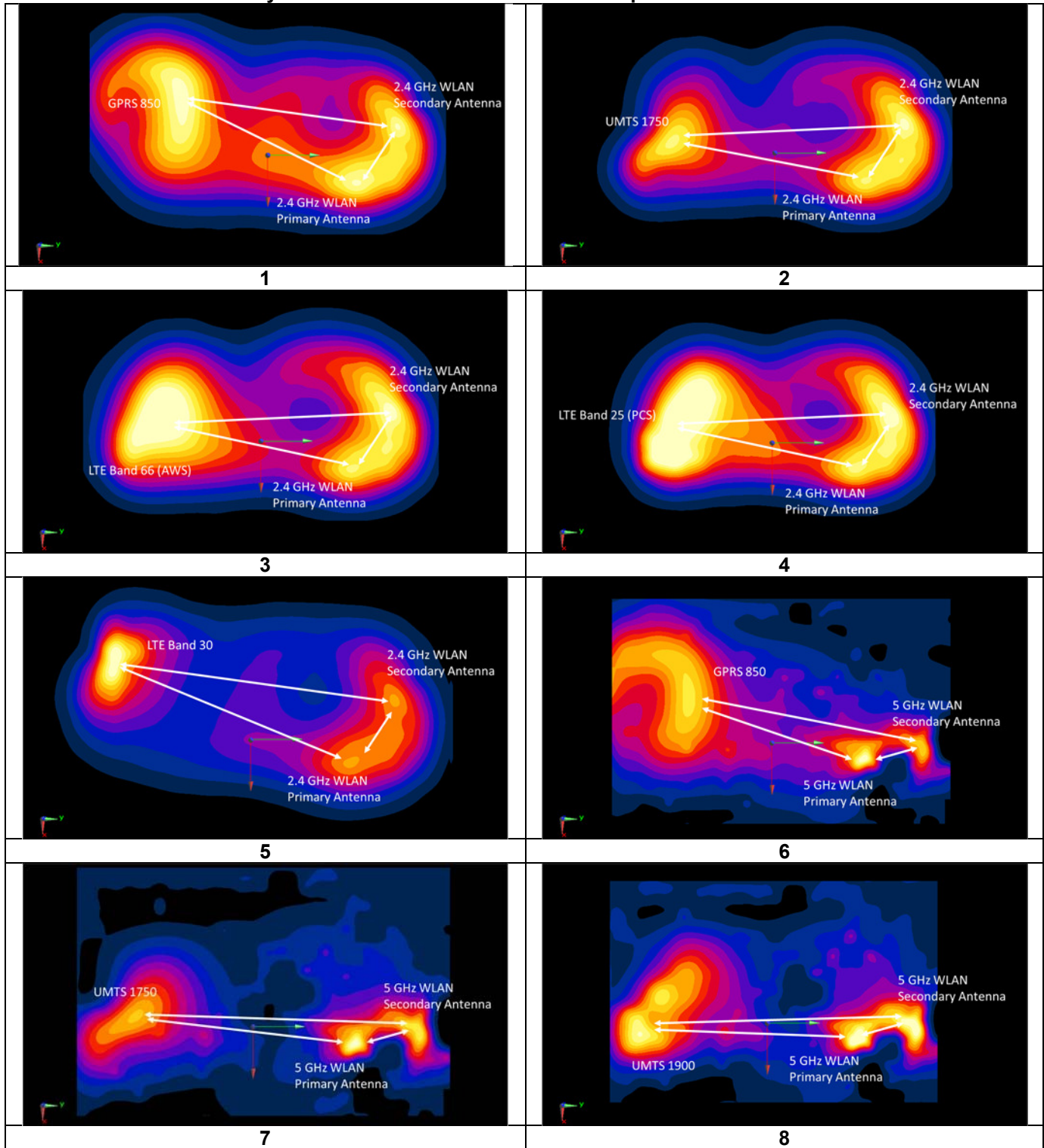

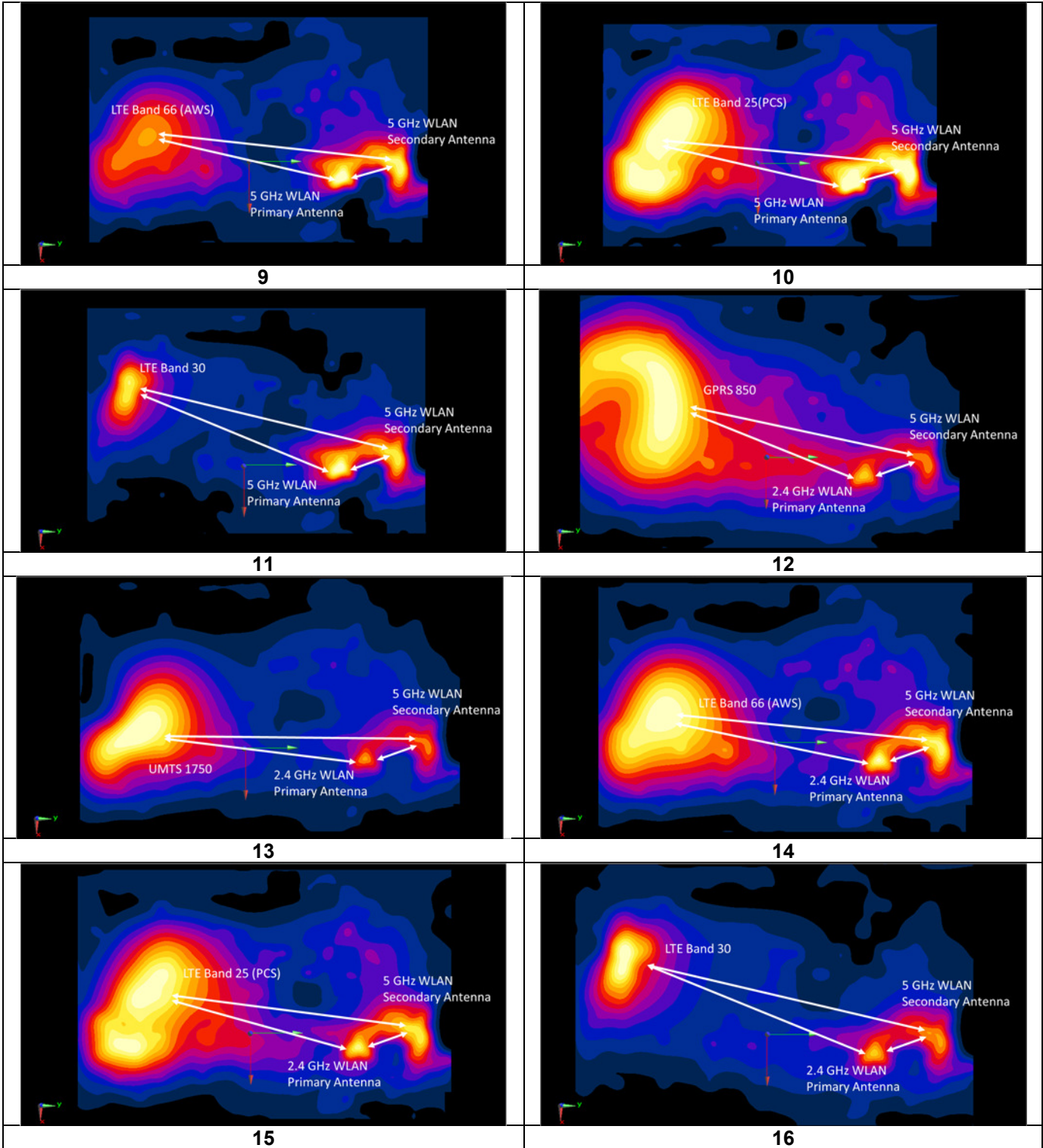
FCC ID: ZNFH871	 <small>PCTEST PROFESSIONAL LABORATORY, INC.</small>	SAR EVALUATION REPORT		Approved by: Quality Manager
Document S/N: 1M1701180032-01-R4.ZNF	Test Dates: 01/20/17 - 01/30/17	DUT Type: Portable Handset		Page 83 of 97

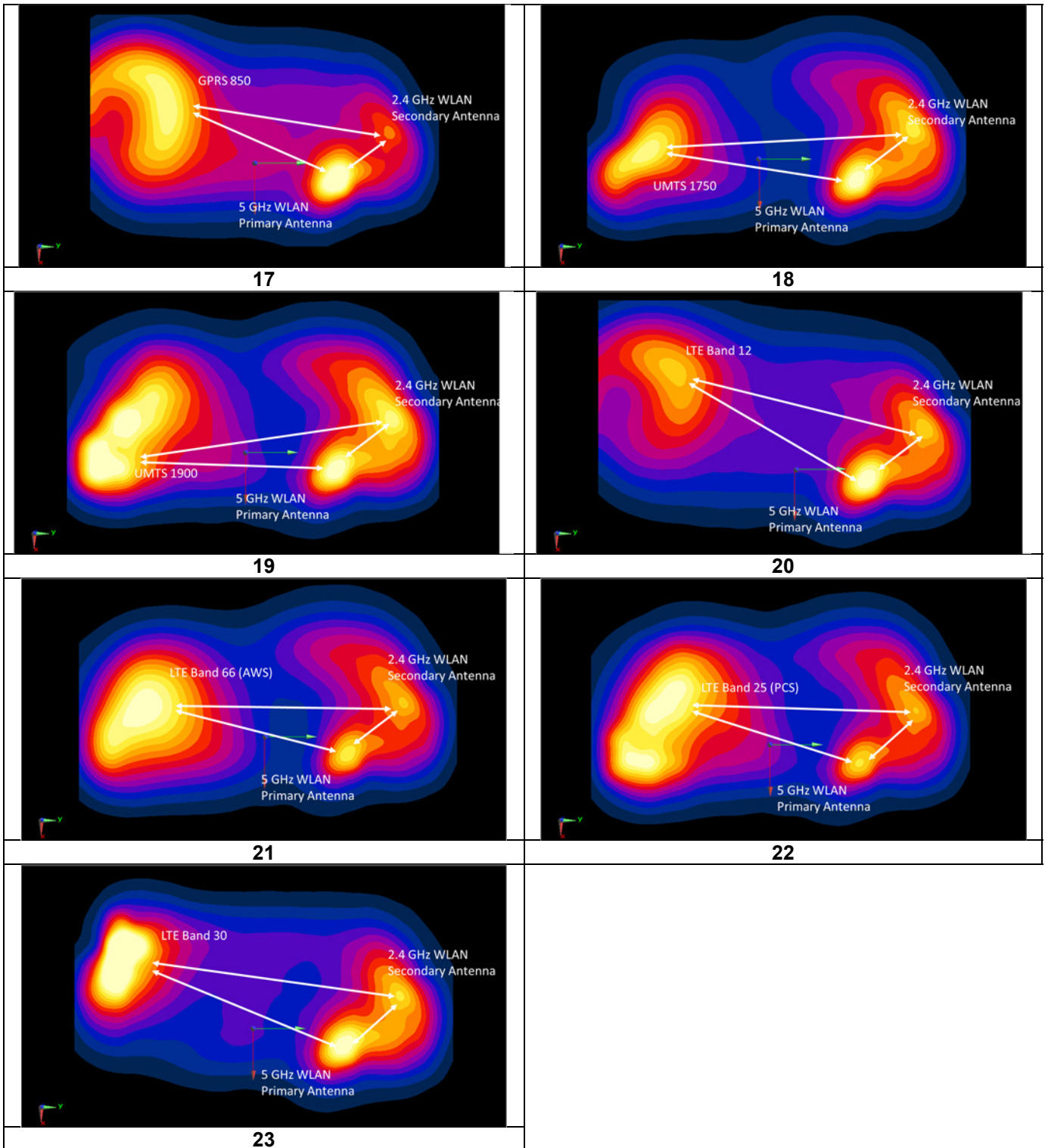

FCC ID: ZNFH871	 PCTEST ENGINEERING LABORATORY, INC.	SAR EVALUATION REPORT	 LG	Approved by: Quality Manager
Document S/N: 1M1701180032-01-R4.ZNF	Test Dates: 01/20/17 - 01/30/17	DUT Type: Portable Handset		Page 84 of 97





FCC ID: ZNFH871	 <small>PCTEST ENGINEERING LABORATORY, INC.</small>	SAR EVALUATION REPORT		Approved by: Quality Manager
Document S/N: 1M1701180032-01-R4.ZNF	Test Dates: 01/20/17 - 01/30/17	DUT Type: Portable Handset	Page 85 of 97	

12.6.2 Hotspot Back Side SPLSR Evaluation and Analysis

**Table 12-17
Peak SAR Locations for Hotspot Back Side**

Mode/Band	x (mm)	y (mm)	Reported SAR (W/kg)
2.4 GHz WLAN Primary Ant	16.60	46.80	0.306
2.4 GHz WLAN Secondary Ant	-15.80	70.80	0.416
5 GHz WLAN Primary Ant	9.00	42.00	0.5
5 GHz WLAN Secondary Ant	6.00	61.00	0.329
GPRS 850	-22.50	-46.50	0.989
UMTS 1750	-5.00	-57.00	0.958
UMTS 1900	2.00	-73.00	0.789
LTE Band 12	-44.00	-49.50	0.688
LTE Band 66 (AWS)	-14.00	-55.50	1.11
LTE Band 25 (PCS)	7.00	-64.50	0.979
LTE Band 30	-37.40	-62.40	1.166

FCC ID: ZNFH871	 PCTEST ENGINEERING LABORATORY, INC.	SAR EVALUATION REPORT	 LG	Approved by: Quality Manager
Document S/N: 1M1701180032-01-R4.ZNF	Test Dates: 01/20/17 - 01/30/17	DUT Type: Portable Handset	Page 86 of 97	

**Table 12-18
Hotspot Back Side SAR Sum to Peak Location Separation Ratio Calculations**

Antenna Pair		Standalone 1g SAR (W/kg)		Standalone SAR Sum (W/kg)	Peak SAR Separation Distance (mm)	SPLS Ratio	Plot Number
Ant "a"	Ant "b"	a	b	a+b	D _{a,b}	(a+b) ^{1.5} /D _{a,b}	
2.4 GHz WLAN Primary Ant	2.4 GHz WLAN Secondary Ant	0.306	0.416	0.722	40.32	0.02	1
GPRS 850	2.4 GHz WLAN Primary Ant	0.989	0.306	1.295	101.16	0.01	
GPRS 850	2.4 GHz WLAN Secondary Ant	0.989	0.416	1.405	117.49	0.01	
2.4 GHz WLAN Primary Ant	2.4 GHz WLAN Secondary Ant	0.306	0.416	0.722	40.32	0.02	2
UMTS 1750	2.4 GHz WLAN Primary Ant	0.958	0.306	1.264	106.02	0.01	
UMTS 1750	2.4 GHz WLAN Secondary Ant	0.958	0.416	1.374	128.26	0.01	
2.4 GHz WLAN Primary Ant	2.4 GHz WLAN Secondary Ant	0.306	0.416	0.722	40.32	0.02	3
LTE Band 66 (AWS)	2.4 GHz WLAN Primary Ant	1.11	0.306	1.416	106.78	0.02	
LTE Band 66 (AWS)	2.4 GHz WLAN Secondary Ant	1.11	0.416	1.526	126.31	0.01	
2.4 GHz WLAN Primary Ant	2.4 GHz WLAN Secondary Ant	0.306	0.416	0.722	40.32	0.02	4
LTE Band 25 (PCS)	2.4 GHz WLAN Primary Ant	0.979	0.306	1.285	111.71	0.01	
LTE Band 25 (PCS)	2.4 GHz WLAN Secondary Ant	0.979	0.416	1.395	137.21	0.01	
2.4 GHz WLAN Primary Ant	2.4 GHz WLAN Secondary Ant	0.306	0.416	0.722	40.32	0.02	5
LTE Band 30	2.4 GHz WLAN Primary Ant	1.166	0.306	1.472	121.82	0.01	
LTE Band 30	2.4 GHz WLAN Secondary Ant	1.166	0.416	1.582	134.94	0.01	
5 GHz WLAN Primary Ant	5 GHz WLAN Secondary Ant	0.5	0.329	0.829	19.24	0.04	6
GPRS 850	5 GHz WLAN Primary Ant	0.989	0.5	1.489	93.94	0.02	
GPRS 850	5 GHz WLAN Secondary Ant	0.989	0.329	1.318	111.21	0.01	
5 GHz WLAN Primary Ant	5 GHz WLAN Secondary Ant	0.5	0.329	0.829	19.24	0.04	7
UMTS 1750	5 GHz WLAN Primary Ant	0.958	0.5	1.458	99.98	0.02	
UMTS 1750	5 GHz WLAN Secondary Ant	0.958	0.329	1.287	118.51	0.01	
5 GHz WLAN Primary Ant	5 GHz WLAN Secondary Ant	0.5	0.329	0.829	19.24	0.04	8
UMTS 1900	5 GHz WLAN Primary Ant	0.789	0.5	1.289	115.21	0.01	
UMTS 1900	5 GHz WLAN Secondary Ant	0.789	0.329	1.118	134.06	0.01	
5 GHz WLAN Primary Ant	5 GHz WLAN Secondary Ant	0.5	0.329	0.829	19.24	0.04	9
LTE Band 66 (AWS)	5 GHz WLAN Primary Ant	1.11	0.5	1.610	100.18	0.02	
LTE Band 66 (AWS)	5 GHz WLAN Secondary Ant	1.11	0.329	1.439	118.20	0.01	
5 GHz WLAN Primary Ant	5 GHz WLAN Secondary Ant	0.5	0.329	0.829	19.24	0.04	10
LTE Band 25 (PCS)	5 GHz WLAN Primary Ant	0.979	0.5	1.479	106.52	0.02	
LTE Band 25 (PCS)	5 GHz WLAN Secondary Ant	0.979	0.329	1.308	125.50	0.01	
5 GHz WLAN Primary Ant	5 GHz WLAN Secondary Ant	0.5	0.329	0.829	19.24	0.04	11
LTE Band 30	5 GHz WLAN Primary Ant	1.166	0.5	1.666	114.25	0.02	
LTE Band 30	5 GHz WLAN Secondary Ant	1.166	0.329	1.495	130.81	0.01	
2.4 GHz WLAN Primary Ant	5 GHz WLAN Secondary Ant	0.306	0.329	0.635	17.72	0.03	12
GPRS 850	2.4 GHz WLAN Primary Ant	0.989	0.306	1.295	101.16	0.01	
GPRS 850	5 GHz WLAN Secondary Ant	0.989	0.329	1.318	111.21	0.01	
2.4 GHz WLAN Primary Ant	5 GHz WLAN Secondary Ant	0.306	0.329	0.635	17.72	0.03	13
UMTS 1750	2.4 GHz WLAN Primary Ant	0.958	0.306	1.264	106.02	0.01	
UMTS 1750	5 GHz WLAN Secondary Ant	0.958	0.329	1.287	118.51	0.01	
2.4 GHz WLAN Primary Ant	5 GHz WLAN Secondary Ant	0.306	0.329	0.635	17.72	0.03	14
LTE Band 66 (AWS)	2.4 GHz WLAN Primary Ant	1.11	0.306	1.416	106.78	0.02	
LTE Band 66 (AWS)	5 GHz WLAN Secondary Ant	1.11	0.329	1.439	118.20	0.01	
2.4 GHz WLAN Primary Ant	5 GHz WLAN Secondary Ant	0.306	0.329	0.635	17.72	0.03	15
LTE Band 25 (PCS)	2.4 GHz WLAN Primary Ant	0.979	0.306	1.285	111.71	0.01	
LTE Band 25 (PCS)	5 GHz WLAN Secondary Ant	0.979	0.329	1.308	125.50	0.01	
2.4 GHz WLAN Primary Ant	5 GHz WLAN Secondary Ant	0.306	0.329	0.635	17.72	0.03	16
LTE Band 30	2.4 GHz WLAN Primary Ant	1.166	0.306	1.472	121.82	0.01	
LTE Band 30	5 GHz WLAN Secondary Ant	1.166	0.329	1.495	130.81	0.01	
2.4 GHz WLAN Secondary Ant	5 GHz WLAN Primary Ant	0.416	0.5	0.916	38.01	0.02	17
GPRS 850	2.4 GHz WLAN Secondary Ant	0.989	0.416	1.405	117.49	0.01	
GPRS 850	5 GHz WLAN Primary Ant	0.989	0.5	1.489	93.94	0.02	
2.4 GHz WLAN Secondary Ant	5 GHz WLAN Primary Ant	0.416	0.5	0.916	38.01	0.02	18
UMTS 1750	2.4 GHz WLAN Secondary Ant	0.958	0.416	1.374	128.26	0.01	
UMTS 1750	5 GHz WLAN Primary Ant	0.958	0.5	1.458	99.98	0.02	
2.4 GHz WLAN Secondary Ant	5 GHz WLAN Primary Ant	0.416	0.5	0.916	38.01	0.02	19
UMTS 1900	2.4 GHz WLAN Secondary Ant	0.789	0.416	1.205	144.90	0.01	
UMTS 1900	5 GHz WLAN Primary Ant	0.789	0.5	1.289	115.21	0.01	
2.4 GHz WLAN Secondary Ant	5 GHz WLAN Primary Ant	0.416	0.5	0.916	38.01	0.02	20
LTE Band 12	2.4 GHz WLAN Secondary Ant	0.688	0.416	1.104	123.56	0.01	
LTE Band 12	5 GHz WLAN Primary Ant	0.688	0.5	1.188	105.74	0.01	
2.4 GHz WLAN Secondary Ant	5 GHz WLAN Primary Ant	0.416	0.5	0.916	38.01	0.02	21
LTE Band 66 (AWS)	2.4 GHz WLAN Secondary Ant	1.11	0.416	1.526	126.31	0.01	
LTE Band 66 (AWS)	5 GHz WLAN Primary Ant	1.11	0.5	1.610	100.18	0.02	
2.4 GHz WLAN Secondary Ant	5 GHz WLAN Primary Ant	0.416	0.5	0.916	38.01	0.02	22
LTE Band 25 (PCS)	2.4 GHz WLAN Secondary Ant	0.979	0.416	1.395	137.21	0.01	
LTE Band 25 (PCS)	5 GHz WLAN Primary Ant	0.979	0.5	1.479	106.52	0.02	
2.4 GHz WLAN Secondary Ant	5 GHz WLAN Primary Ant	0.416	0.5	0.916	38.01	0.02	23
LTE Band 30	2.4 GHz WLAN Secondary Ant	1.166	0.416	1.582	134.94	0.01	
LTE Band 30	5 GHz WLAN Primary Ant	1.166	0.5	1.666	114.25	0.02	







FCC ID: ZNFH871	 SAR EVALUATION REPORT 	Approved by: Quality Manager
Document S/N: 1M1701180032-01-R4.ZNF	Test Dates: 01/20/17 - 01/30/17	DUT Type: Portable Handset
		Page 87 of 97

Table 12-19
Back Side SAR Sum to Peak Location Separation Ratio Plots



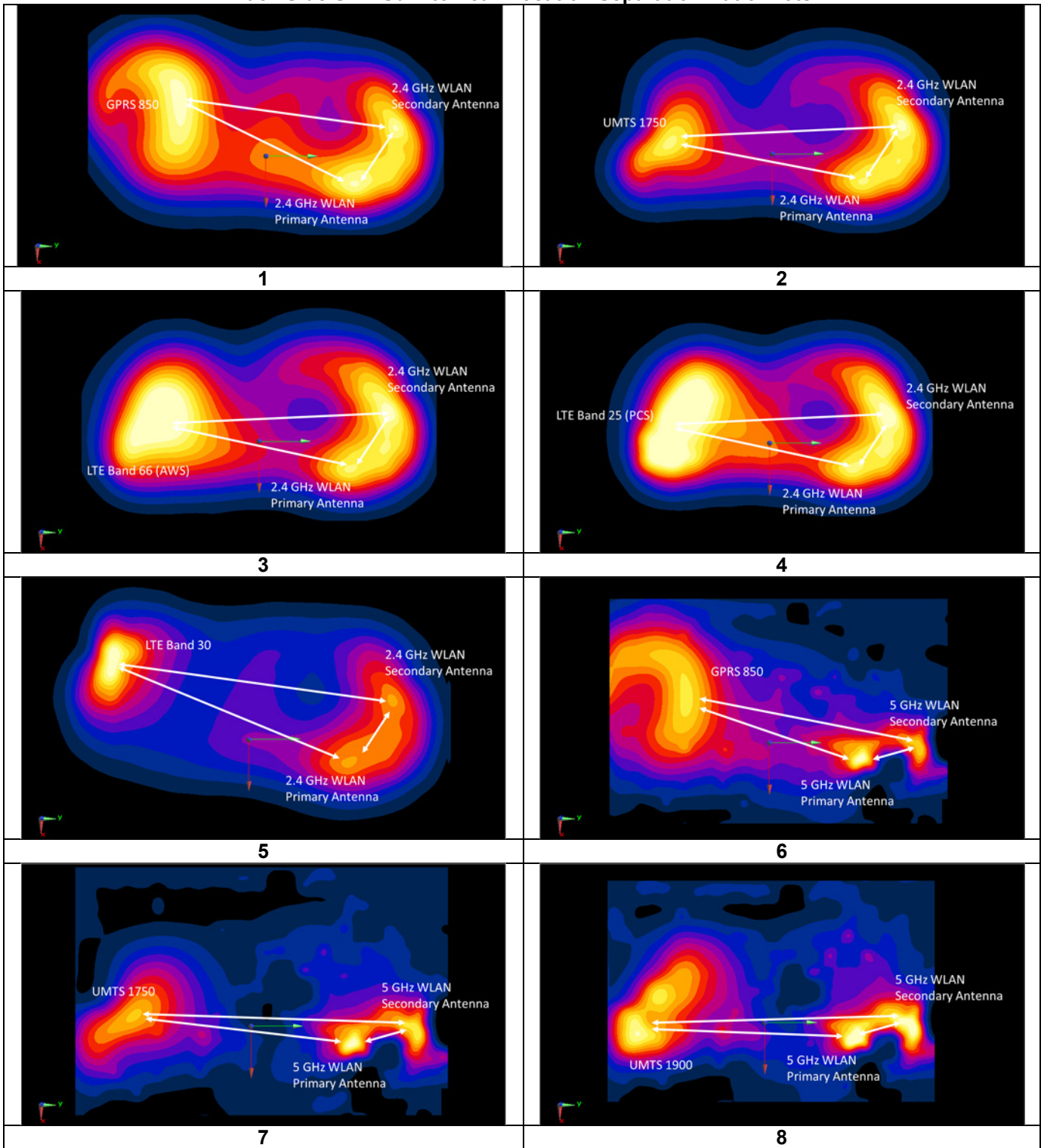

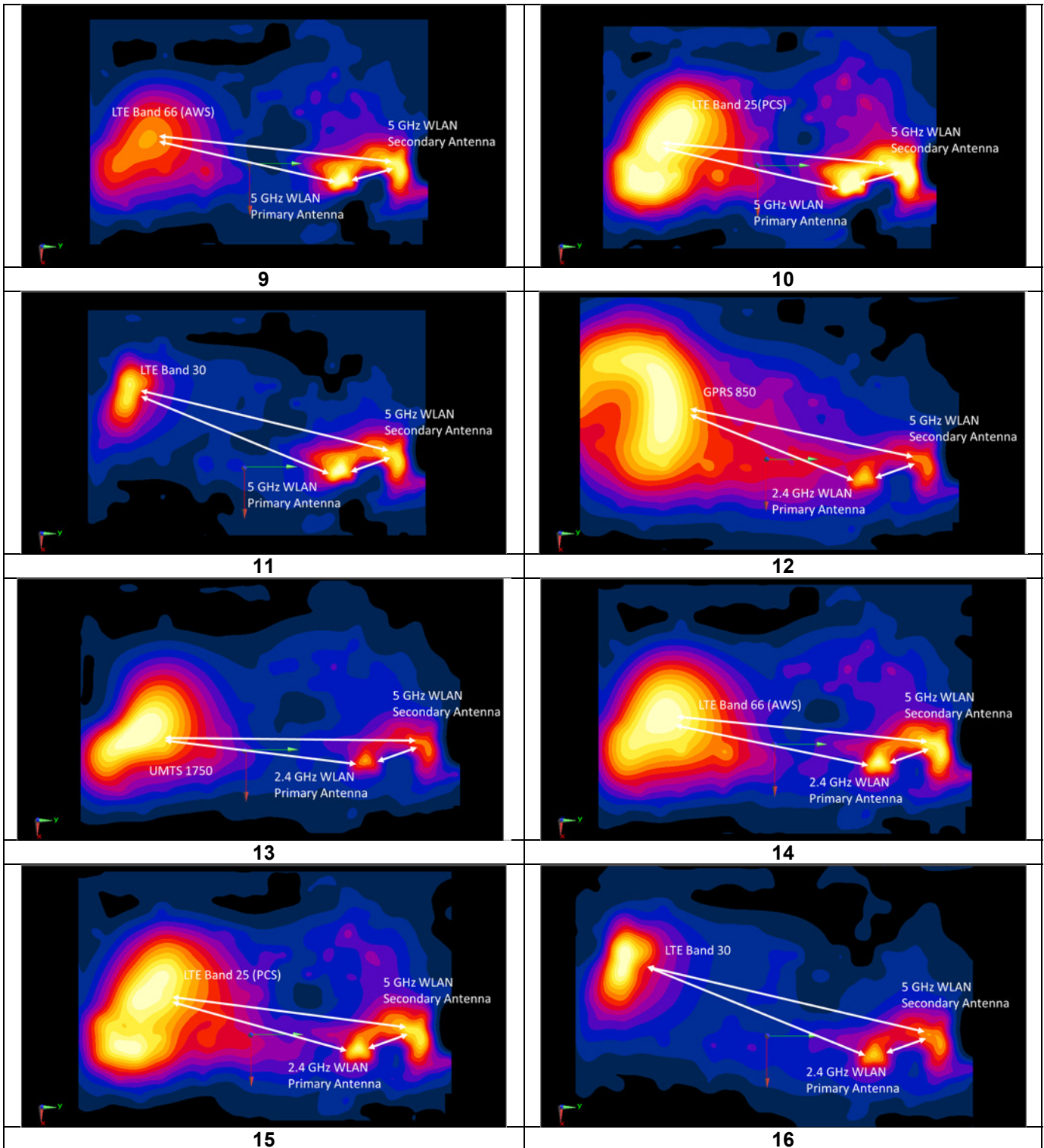
FCC ID: ZNFH871	 <small>PCTEST ENGINEERING LABORATORY, INC.</small>	SAR EVALUATION REPORT		Approved by: Quality Manager
Document S/N: 1M1701180032-01-R4.ZNF	Test Dates: 01/20/17 - 01/30/17	DUT Type: Portable Handset	Page 88 of 97	

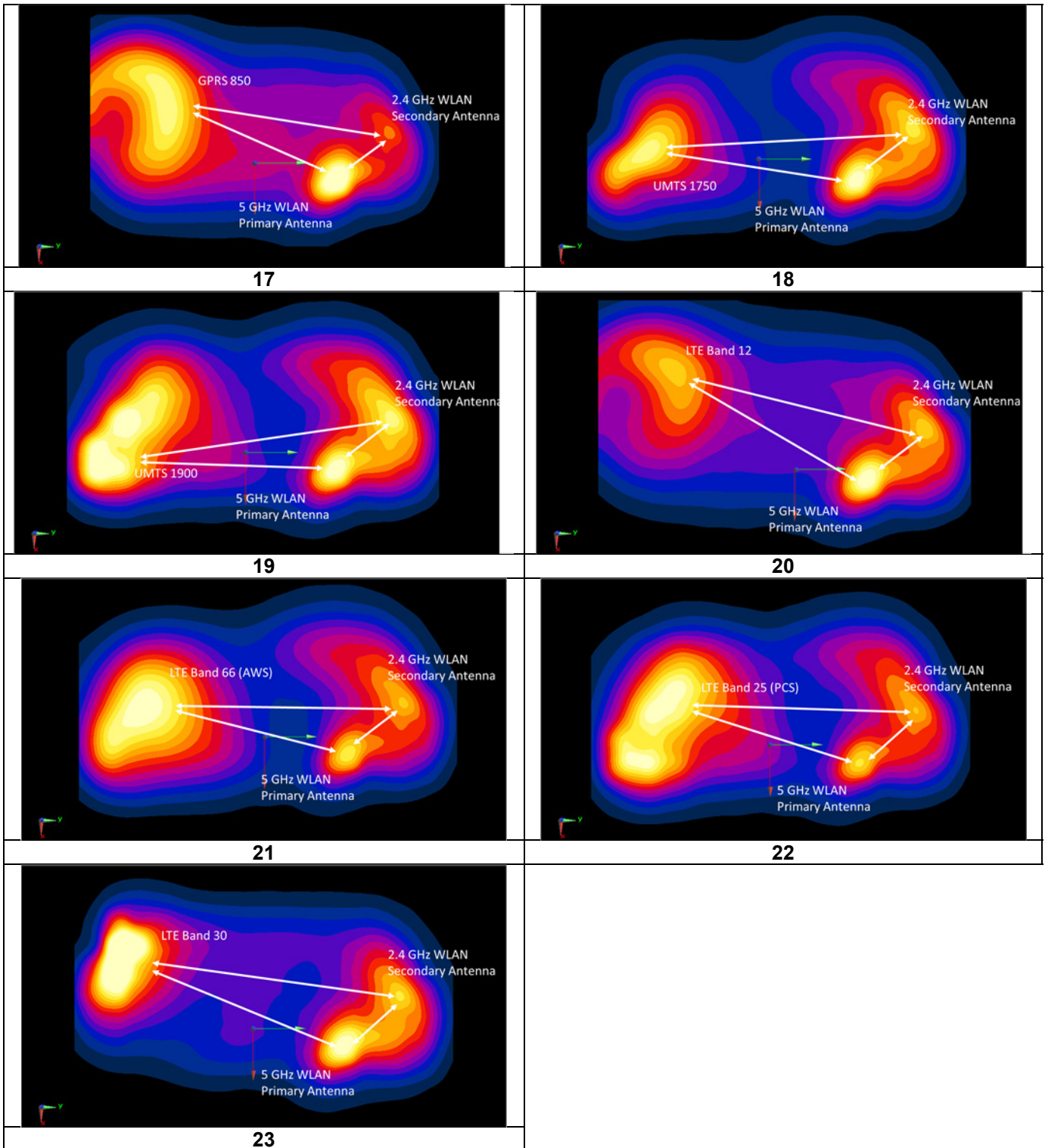

FCC ID: ZNFH871	 PCTEST ENGINEERING LABORATORY, INC.	SAR EVALUATION REPORT	 LG	Approved by: Quality Manager
Document S/N: 1M1701180032-01-R4.ZNF	Test Dates: 01/20/17 - 01/30/17	DUT Type: Portable Handset		Page 89 of 97



FCC ID: ZNFH871	 <small>PCTEST ENGINEERING LABORATORY, INC.</small>	SAR EVALUATION REPORT		Approved by: Quality Manager
Document S/N: 1M1701180032-01-R4.ZNF	Test Dates: 01/20/17 - 01/30/17	DUT Type: Portable Handset	Page 90 of 97	

12.6.3 Hotspot Front Side SPLSR Evaluation and Analysis

Table 12-20
Peak SAR Locations for Hotspot Front Side

Mode/Band	x (mm)	y (mm)	Reported SAR (W/kg)
2.4 GHz WLAN Primary Ant	-51.80	51.60	0.326
2.4 GHz WLAN Secondary Ant	-13.20	70.80	0.399
GPRS 850	2.00	-54.50	1.06
LTE Band 66 (AWS)	-16.00	-63.50	1.1

Table 12-21
Hotspot Front Side SAR Sum to Peak Location Separation Ratio Calculations

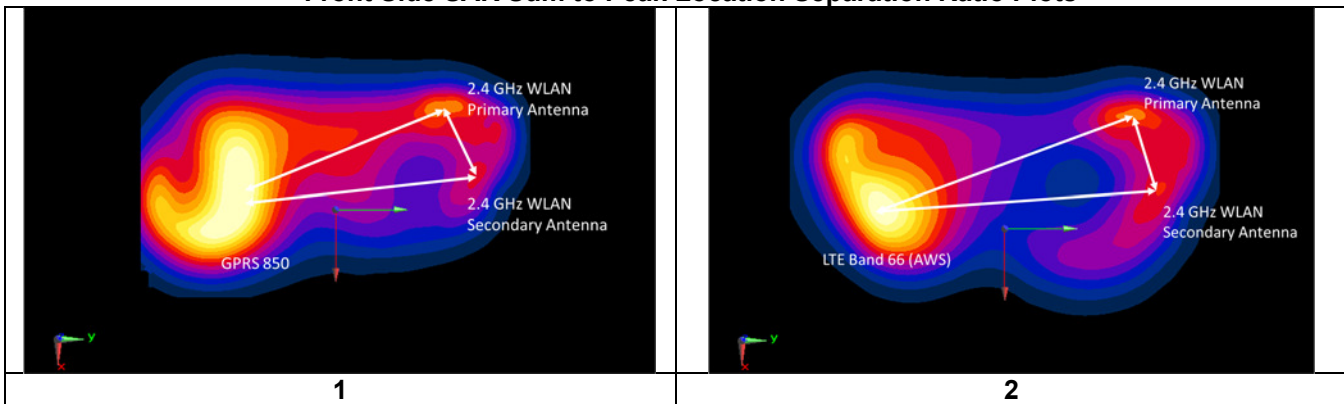

Antenna Pair		Standalone 1g SAR (W/kg)		Standalone SAR Sum (W/kg)	Peak SAR Separation Distance (mm)	SPLSR Ratio	Plot Number
Ant "a"	Ant "b"	a	b	a+b	D _{a-b}	(a+b) ^{1.5} /D _{a-b}	
2.4 GHz WLAN Primary Ant	2.4 GHz WLAN Secondary Ant	0.326	0.399	0.725	43.11	0.01	1
GPRS 850	2.4 GHz WLAN Primary Ant	1.06	0.326	1.386	118.96	0.01	
GPRS 850	2.4 GHz WLAN Secondary Ant	1.06	0.399	1.459	126.22	0.01	
2.4 GHz WLAN Primary Ant	2.4 GHz WLAN Secondary Ant	0.326	0.399	0.725	43.11	0.01	2
LTE Band 66 (AWS)	2.4 GHz WLAN Primary Ant	1.1	0.326	1.426	120.54	0.01	
LTE Band 66 (AWS)	2.4 GHz WLAN Secondary Ant	1.1	0.399	1.499	134.33	0.01	

Table 12-22
Front Side SAR Sum to Peak Location Separation Ratio Plots



12.7 Simultaneous Transmission Conclusion

The above numerical summed SAR results and SPLSR results for all the worst-case simultaneous transmission conditions were below the SAR limit. Therefore, the above analysis is sufficient to determine that simultaneous transmission cases will not exceed the SAR limit and therefore no measured volumetric simultaneous SAR summation is required per FCC KDB Publication 447498 D01v06 and IEEE 1528-2013 Section 6.3.4.1.2.

FCC ID: ZNFH871	 PCTEST PROFESSIONAL LABORATORY, INC.	SAR EVALUATION REPORT	 LG	Approved by: Quality Manager
Document S/N: 1M1701180032-01-R4.ZNF	Test Dates: 01/20/17 - 01/30/17	DUT Type: Portable Handset	Page 91 of 97	

13 SAR MEASUREMENT VARIABILITY

13.1 Measurement Variability

Per FCC KDB Publication 865664 D01v01r04, SAR measurement variability was assessed for each frequency band, which was determined by the SAR probe calibration point and tissue-equivalent medium used for the device measurements. When both head and body tissue-equivalent media were required for SAR measurements in a frequency band, the variability measurement procedures were applied to the tissue medium with the highest measured SAR, using the highest measured SAR configuration for that tissue-equivalent medium. These additional measurements were repeated after the completion of all measurements requiring the same head or body tissue-equivalent medium in a frequency band. The test device was returned to ambient conditions (normal room temperature) with the battery fully charged before it was re-mounted on the device holder for the repeated measurement(s) to minimize any unexpected variations in the repeated results.

SAR Measurement Variability was assessed using the following procedures for each frequency band:



- 1) When the original highest measured SAR is ≥ 0.80 W/kg, the measurement was repeated once.
- 2) A second repeated measurement was performed only if the ratio of largest to smallest SAR for the original and first repeated measurements was > 1.20 or when the original or repeated measurement was ≥ 1.45 W/kg (~ 10% from the 1-g SAR limit).
- 3) A third repeated measurement was performed only if the original, first or second repeated measurement was ≥ 1.5 W/kg and the ratio of largest to smallest SAR for the original, first and second repeated measurements is > 1.20 .
- 4) Repeated measurements are not required when the original highest measured SAR is < 0.80 W/kg

**Table 13-1
Body SAR Measurement Variability Results**

BODY VARIABILITY RESULTS														
Band	FREQUENCY		Mode	Service	# of Time Slots	Side	Spacing	Measured SAR (1g)	1st Repeated SAR (1g)	Ratio	2nd Repeated SAR (1g)	Ratio	3rd Repeated SAR (1g)	Ratio
	MHz	Ch.						(W/kg)	(W/kg)		(W/kg)		(W/kg)	
835	836.60	190	GSM850	GPRS	3	front	10 mm	1.060	1.040	1.02	N/A	N/A	N/A	N/A
1750	1745.00	132322	LTE Band 66 (AWS), 20 MHz Bandwidth	QPSK, 1 RB, 50 RB Offset	N/A	back	10 mm	1.100	1.030	1.07	N/A	N/A	N/A	N/A
1900	1882.50	26365	LTE Band 25 (PCS), 20 MHz Bandwidth	QPSK, 1 RB, 0 RB Offset	N/A	bottom	10 mm	1.190	1.080	1.10	N/A	N/A	N/A	N/A
2300	2310.00	27710	LTE Band 30, 10 MHz Bandwidth	QPSK, 1 RB, 0 RB Offset	N/A	back	10 mm	1.160	1.030	1.13	N/A	N/A	N/A	N/A
ANSI / IEEE C95.1 1992 - SAFETY LIMIT							Body							
Spatial Peak							1.6 W/kg (mW/g)							
Uncontrolled Exposure/General Population							averaged over 1 gram							

13.2 Measurement Uncertainty

The measured SAR was < 1.5 W/kg for all frequency bands. Therefore, per KDB Publication 865664 D01v01r04, the extended measurement uncertainty analysis per IEEE 1528-2013 was not required.



FCC ID: ZNFH871		SAR EVALUATION REPORT		Approved by: Quality Manager
Document S/N: 1M1701180032-01-R4.ZNF	Test Dates: 01/20/17 - 01/30/17	DUT Type: Portable Handset		Page 92 of 97

14 EQUIPMENT LIST

Manufacturer	Model	Description	Cal Date	Cal Interval	Cal Due	Serial Number
Agilent	E8257D	(250kHz-20GHz) Signal Generator	3/2/2016	Annual	3/2/2017	MY45470194
Agilent	8753E	(30kHz-6GHz) Network Analyzer	3/2/2016	Annual	3/2/2017	JP38020182
Agilent	E4438C	ESG Vector Signal Generator	3/13/2015	Biennial	3/13/2017	MY42082385
Agilent	E4432B	ESG-D Series Signal Generator	3/5/2016	Annual	3/5/2017	US40053896
Agilent	N5182A	MXG Vector Signal Generator	10/27/2016	Annual	10/27/2017	MY47420603
Agilent	8753ES	S-Parameter Network Analyzer	10/26/2016	Annual	10/26/2017	US39170118
Agilent	8753ES	S-Parameter Vector Network Analyzer	8/19/2016	Annual	8/19/2017	MY40003841
Agilent	E5515C	Wireless Communications Test Set	1/29/2016	Biennial	1/29/2018	GB46310798
Agilent	N4010A	Wireless Connectivity Test Set	CBT	N/A	CBT	GB44450273
Amplifier Research	15S1G6	Amplifier	CBT	N/A	CBT	433971
Anritsu	ML2495A	Power Meter	10/16/2015	Biennial	10/16/2017	941001
Anritsu	MA2411B	Pulse Power Sensor	8/18/2016	Annual	8/18/2017	1126066
Anritsu	MT8820C	Radio Communication Analyzer	9/15/2016	Annual	9/15/2017	6200901190
Anritsu	MA24106A	USB Power Sensor	6/2/2016	Annual	6/2/2017	1231538
COMTech	AR85729-5	Solid State Amplifier	CBT	N/A	CBT	M155A00-009
Control Company	4040	Digital Thermometer	3/15/2015	Biennial	3/15/2017	150194929
Control Company	4353	Long Stem Thermometer	3/5/2015	Biennial	3/5/2017	150149565
Control Company	4352	Ultra Long Stem Thermometer	3/8/2016	Biennial	3/8/2018	160261701
Keysight	772D	Dual Directional Coupler	CBT	N/A	CBT	MY52180215
MCL	BW-N6W5+	6dB Attenuator	CBT	N/A	CBT	1139
MiniCircuits	SLP-2400+	Low Pass Filter	CBT	N/A	CBT	R8979500903
MiniCircuits	VLF-6000+	Low Pass Filter	CBT	N/A	CBT	N/A
Mini-Circuits	BW-N20W5+	DC to 18 GHz Precision Fixed 20 dB Attenuator	CBT	N/A	CBT	N/A
Mini-Circuits	NLP-1200+	Low Pass Filter DC to 1000 MHz	CBT	N/A	CBT	N/A
Mini-Circuits	NLP-2950+	Low Pass Filter DC to 2700 MHz	CBT	N/A	CBT	N/A
Mini-Circuits	BW-N20W5	Power Attenuator	CBT	N/A	CBT	1226
Mitutoyo	CD-6"CSX	Digital Caliper	3/2/2016	Biennial	3/2/2018	13264162
Narda	4014C-6	4 - 8 GHz SMA 6 dB Directional Coupler	CBT	N/A	CBT	N/A
Narda	4772-3	Attenuator (3dB)	CBT	N/A	CBT	9406
Pasternack	PE2208-6	Bidirectional Coupler	CBT	N/A	CBT	N/A
Pasternack	PE2209-10	Bidirectional Coupler	CBT	N/A	CBT	N/A
Pasternack	NC-100	Torque Wrench	11/6/2015	Biennial	11/6/2017	N/A
Rohde & Schwarz	CMU200	Base Station Simulator	3/29/2016	Annual	3/29/2017	836371/0079
Rohde & Schwarz	CMW500	Radio Communication Tester	10/20/2016	Annual	10/20/2017	100976
Rohde & Schwarz	CMW500	Radio Communication Tester	4/26/2016	Annual	4/26/2017	112347
Seekonk	NC-100	Torque Wrench	11/6/2015	Biennial	11/6/2017	22313
SPEAG	DAK-3.5	Dielectric Assessment Kit	9/13/2016	Annual	9/13/2017	1091
SPEAG	DAK-12	Dielectric Assessment Kit (10MHz - 3GHz)	3/1/2016	Annual	3/1/2017	1102
SPEAG	DAKS-3.5	Portable Dielectric Assessment Kit	7/19/2016	Annual	7/19/2017	1039
SPEAG	D750V3	750 MHz SAR Dipole	7/13/2016	Annual	7/13/2017	1161
SPEAG	D835V2	835 MHz SAR Dipole	7/13/2016	Annual	7/13/2017	40407
SPEAG	D1750V2	1750 MHz SAR Dipole	5/9/2016	Annual	5/9/2017	1148
SPEAG	D1900V2	1900 MHz SAR Dipole	7/15/2016	Annual	7/15/2017	50149
SPEAG	D2300V2	2300 MHz SAR Dipole	11/15/2016	Annual	11/15/2017	1064
SPEAG	D2450V2	2450 MHz SAR Dipole	9/13/2016	Annual	9/13/2017	797
SPEAG	D2600V2	2600 MHz SAR Dipole	9/13/2016	Annual	9/13/2017	1071
SPEAG	D5GHzV2	5 GHz SAR Dipole	9/21/2016	Annual	9/21/2017	1191
SPEAG	D1900V2	1900 MHz SAR Dipole	7/8/2016	Annual	7/8/2017	50080
SPEAG	D2450V2	2450 MHz SAR Dipole	7/25/2016	Annual	7/25/2017	981
SPEAG	D5GHzV2	5 GHz SAR Dipole	8/2/2016	Annual	8/2/2017	1237
SPEAG	ES3DV3	SAR Probe	3/18/2016	Annual	3/18/2017	3209
SPEAG	ES3DV3	SAR Probe	9/19/2016	Annual	9/19/2017	3287
SPEAG	ES3DV3	SAR Probe	8/25/2016	Annual	8/25/2017	3332
SPEAG	EX3DV4	SAR Probe	4/19/2016	Annual	4/19/2017	7357
SPEAG	ES3DV3	SAR Probe	3/18/2016	Annual	3/18/2017	3319
SPEAG	ES3DV3	SAR Probe	2/19/2016	Annual	2/19/2017	3213
SPEAG	EX3DV4	SAR Probe	5/17/2016	Annual	5/17/2017	7409
SPEAG	EX3DV4	SAR Probe	4/19/2016	Annual	4/19/2017	7406
SPEAG	EX3DV4	SAR Probe	2/22/2016	Annual	2/22/2017	3914
SPEAG	DAE4	Dasy Data Acquisition Electronics	8/22/2016	Annual	8/22/2017	1364
SPEAG	DAE4	Dasy Data Acquisition Electronics	9/14/2016	Annual	9/14/2017	1408
SPEAG	DAE4	Dasy Data Acquisition Electronics	9/15/2016	Annual	9/15/2017	1333
SPEAG	DAE4	Dasy Data Acquisition Electronics	2/19/2016	Annual	2/19/2017	665
SPEAG	DAE4	Dasy Data Acquisition Electronics	3/14/2016	Annual	3/14/2017	1368
SPEAG	DAE4	Dasy Data Acquisition Electronics	2/18/2016	Annual	2/18/2017	1272
SPEAG	DAE4	Dasy Data Acquisition Electronics	5/11/2016	Annual	5/11/2017	859
SPEAG	DAE4	Dasy Data Acquisition Electronics	4/14/2016	Annual	4/14/2017	1407



Note:

1. CBT (Calibrated Before Testing). Prior to testing, the measurement paths containing a cable, amplifier, attenuator, coupler or filter were connected to a calibrated source (i.e. a signal generator) to determine the losses of the measurement path. The power meter offset was then adjusted to compensate for the measurement system losses. This level offset is stored within the power meter before measurements are made. This calibration verification procedure applies to the system verification and output power measurements. The calibrated reading is then taken directly from the power meter after compensation of the losses for all final power measurements.
2. All equipment were used solely within its calibration period.

FCC ID: ZNFH871		SAR EVALUATION REPORT		Approved by: Quality Manager
Document S/N: 1M1701180032-01-R4.ZNF	Test Dates: 01/20/17 - 01/30/17	DUT Type: Portable Handset		Page 93 of 97

15 MEASUREMENT UNCERTAINTIES

a	c	d	e= f(d,k)	f	g	h = c x f/e	i = c x g/e	k
Uncertainty Component	Tol. (± %)	Prob. Dist.	Div.	c _i 1gm	c _i 10 gms	1gm u _i (± %)	10gms u _i (± %)	v _i
Measurement System								
Probe Calibration	6.55	N	1	1.0	1.0	6.6	6.6	∞
Axial Isotropy	0.25	N	1	0.7	0.7	0.2	0.2	∞
Hemishperical Isotropy	1.3	N	1	0.7	0.7	0.9	0.9	∞
Boundary Effect	2.0	R	1.73	1.0	1.0	1.2	1.2	∞
Linearity	0.3	N	1	1.0	1.0	0.3	0.3	∞
System Detection Limits	0.25	R	1.73	1.0	1.0	0.1	0.1	∞
Readout Electronics	0.3	N	1	1.0	1.0	0.3	0.3	∞
Response Time	0.8	R	1.73	1.0	1.0	0.5	0.5	∞
Integration Time	2.6	R	1.73	1.0	1.0	1.5	1.5	∞
RF Ambient Conditions - Noise	3.0	R	1.73	1.0	1.0	1.7	1.7	∞
RF Ambient Conditions - Reflections	3.0	R	1.73	1.0	1.0	1.7	1.7	∞
Probe Positioner Mechanical Tolerance	0.4	R	1.73	1.0	1.0	0.2	0.2	∞
Probe Positioning w/ respect to Phantom	6.7	R	1.73	1.0	1.0	3.9	3.9	∞
Extrapolation, Interpolation & Integration algorithms for Max. SAR Evaluation	4.0	R	1.73	1.0	1.0	2.3	2.3	∞
Test Sample Related								
Test Sample Positioning	2.7	N	1	1.0	1.0	2.7	2.7	35
Device Holder Uncertainty	1.67	N	1	1.0	1.0	1.7	1.7	5
Output Power Variation - SAR drift measurement	5.0	R	1.73	1.0	1.0	2.9	2.9	∞
SAR Scaling	0.0	R	1.73	1.0	1.0	0.0	0.0	∞
Phantom & Tissue Parameters								
Phantom Uncertainty (Shape & Thickness tolerances)	7.6	R	1.73	1.0	1.0	4.4	4.4	∞
Liquid Conductivity - measurement uncertainty	4.2	N	1	0.78	0.71	3.3	3.0	10
Liquid Permittivity - measurement uncertainty	4.1	N	1	0.23	0.26	1.0	1.1	10
Liquid Conductivity - Temperature Uncertainty	3.4	R	1.73	0.78	0.71	1.5	1.4	∞
Liquid Permittivity - Temperature Uncertainty	0.6	R	1.73	0.23	0.26	0.1	0.1	∞
Liquid Conductivity - deviation from target values	5.0	R	1.73	0.64	0.43	1.8	1.2	∞
Liquid Permittivity - deviation from target values	5.0	R	1.73	0.60	0.49	1.7	1.4	∞
Combined Standard Uncertainty (k=1)	RSS					11.5	11.3	60
Expanded Uncertainty (95% CONFIDENCE LEVEL)	k=2					23.0	22.6	



FCC ID: ZNFH871	 PCTEST ENGINEERING LABORATORY, INC.	SAR EVALUATION REPORT			Approved by: Quality Manager
Document S/N: 1M1701180032-01-R4.ZNF	Test Dates: 01/20/17 - 01/30/17	DUT Type: Portable Handset			Page 94 of 97

16 CONCLUSION

16.1 Measurement Conclusion



The SAR evaluation indicates that the EUT complies with the RF radiation exposure limits of the FCC and Innovation, Science, and Economic Development Canada, with respect to all parameters subject to this test. These measurements were taken to simulate the RF effects of RF exposure under worst-case conditions. Precise laboratory measures were taken to assure repeatability of the tests. The results and statements relate only to the item(s) tested.

Please note that the absorption and distribution of electromagnetic energy in the body are very complex phenomena that depend on the mass, shape, and size of the body, the orientation of the body with respect to the field vectors, and the electrical properties of both the body and the environment. Other variables that may play a substantial role in possible biological effects are those that characterize the environment (e.g. ambient temperature, air velocity, relative humidity, and body insulation) and those that characterize the individual (e.g. age, gender, activity level, debilitation, or disease). Because various factors may interact with one another to vary the specific biological outcome of an exposure to electromagnetic fields, any protection guide should consider maximal amplification of biological effects as a result of field-body interactions, environmental conditions, and physiological variables. [3]



FCC ID: ZNFH871		SAR EVALUATION REPORT		Approved by: Quality Manager
Document S/N: 1M1701180032-01-R4.ZNF	Test Dates: 01/20/17 - 01/30/17	DUT Type: Portable Handset		Page 95 of 97

17 REFERENCES

- [1] Federal Communications Commission, ET Docket 93-62, Guidelines for Evaluating the Environmental Effects of Radiofrequency Radiation, Aug. 1996.
- [2] ANSI/IEEE C95.1-2005, American National Standard safety levels with respect to human exposure to radio frequency electromagnetic fields, 3kHz to 300GHz, New York: IEEE, 2006.
- [3] ANSI/IEEE C95.1-1992, American National Standard safety levels with respect to human exposure to radio frequency electromagnetic fields, 3kHz to 300GHz, New York: IEEE, Sept. 1992.
- [4] ANSI/IEEE C95.3-2002, IEEE Recommended Practice for the Measurement of Potentially Hazardous Electromagnetic Fields - RF and Microwave, New York: IEEE, December 2002.
- [5] IEEE Standards Coordinating Committee 39 –Standards Coordinating Committee 34 – IEEE Std. 1528-2013, IEEE Recommended Practice for Determining the Peak Spatial-Average Specific Absorption Rate (SAR) in the Human Head from Wireless Communications Devices: Measurement Techniques.
- [6] NCRP, National Council on Radiation Protection and Measurements, Biological Effects and Exposure Criteria for RadioFrequency Electromagnetic Fields, NCRP Report No. 86, 1986. Reprinted Feb. 1995.
- [7] T. Schmid, O. Egger, N. Kuster, Automated E-field scanning system for dosimetric assessments, IEEE Transaction on Microwave Theory and Techniques, vol. 44, Jan. 1996, pp. 105-113.
- [8] K. Pokovic, T. Schmid, N. Kuster, Robust setup for precise calibration of E-field probes in tissue simulating liquids at mobile communications frequencies, ICECOM97, Oct. 1997, pp. 1 -124.
- [9] K. Pokovic, T. Schmid, and N. Kuster, E-field Probe with improved isotropy in brain simulating liquids, Proceedings of the ELMAR, Zadar, Croatia, June 23-25, 1996, pp. 172-175.
- [10] Schmid & Partner Engineering AG, Application Note: Data Storage and Evaluation, June 1998, p2.
- [11] V. Hombach, K. Meier, M. Burkhardt, E. Kuhn, N. Kuster, The Dependence of EM Energy Absorption upon Human Modeling at 900 MHz, IEEE Transaction on Microwave Theory and Techniques, vol. 44 no. 10, Oct. 1996, pp. 1865-1873.
- [12] N. Kuster and Q. Balzano, Energy absorption mechanism by biological bodies in the near field of dipole antennas above 300MHz, IEEE Transaction on Vehicular Technology, vol. 41, no. 1, Feb. 1992, pp. 17-23.
- [13] G. Hartsgrove, A. Kraszewski, A. Surowiec, Simulated Biological Materials for Electromagnetic Radiation Absorption Studies, University of Ottawa, Bioelectromagnetics, Canada: 1987, pp. 29-36.
- [14] Q. Balzano, O. Garay, T. Manning Jr., Electromagnetic Energy Exposure of Simulated Users of Portable Cellular Telephones, IEEE Transactions on Vehicular Technology, vol. 44, no.3, Aug. 1995.
- [15] W. Gander, Computermathematick, Birkhaeuser, Basel, 1992.
- [16] W.H. Press, S.A. Teukolsky, W.T. Vetterling, and B.P. Flannery, Numerical Recipes in C, The Art of Scientific Computing, Second edition, Cambridge University Press, 1992.
- [17] N. Kuster, R. Kastle, T. Schmid, Dosimetric evaluation of mobile communications equipment with known precision, IEEE Transaction on Communications, vol. E80-B, no. 5, May 1997, pp. 645-652.

FCC ID: ZNFH871	 PCTEST ENGINEERING LABORATORY, INC.	SAR EVALUATION REPORT	 LG	Approved by: Quality Manager
Document S/N: 1M1701180032-01-R4.ZNF	Test Dates: 01/20/17 - 01/30/17	DUT Type: Portable Handset		Page 96 of 97

- [18] CENELEC CLC/SC111B, European Prestandard (prENV 50166-2), Human Exposure to Electromagnetic Fields High-frequency: 10kHz-300GHz, Jan. 1995.
- [19] Prof. Dr. Niels Kuster, ETH, Eidgenössische Technische Hochschule Zürich, Dosimetric Evaluation of the Cellular Phone.
- [20] IEC 62209-1, Human exposure to radio frequency fields from hand-held and body-mounted wireless communication devices - Human models, instrumentation, and procedures - Part 1: Procedure to determine the specific absorption rate (SAR) for hand-held devices used in close proximity to the ear (frequency range of 300 MHz to 3 GHz), Feb. 2005.
- [21] Innovation, Science, Economic Development Canada RSS-102 Radio Frequency Exposure Compliance of Radiocommunication Apparatus (All Frequency Bands) Issue 5, March 2015.
- [22] Health Canada Safety Code 6 Limits of Human Exposure to Radio Frequency Electromagnetic Fields in the Frequency Range from 3 kHz – 300 GHz, 2015
- [23] FCC SAR Test Procedures for 2G-3G Devices, Mobile Hotspot and UMPC Devices KDB Publications 941225, D01-D07
- [24] SAR Measurement Guidance for IEEE 802.11 Transmitters, KDB Publication 248227 D01
- [25] FCC SAR Considerations for Handsets with Multiple Transmitters and Antennas, KDB Publications 648474 D03-D04
- [26] FCC SAR Evaluation Considerations for Laptop, Notebook, Netbook and Tablet Computers, FCC KDB Publication 616217 D04
- [27] FCC SAR Measurement and Reporting Requirements for 100MHz – 6 GHz, KDB Publications 865664 D01-D02
- [28] FCC General RF Exposure Guidance and SAR Procedures for Dongles, KDB Publication 447498, D01-D02
- [29] Anexo à Resolução No. 533, de 10 de Setembro de 2009.
- [30] IEC 62209-2, Human exposure to radio frequency fields from hand-held and body-mounted wireless communication devices - Human models, instrumentation, and procedures - Part 2: Procedure to determine the specific absorption rate (SAR) for wireless communication devices used in close proximity to the human body (frequency range of 30 MHz to 6 GHz), Mar. 2010.

FCC ID: ZNFH871	 SAR EVALUATION REPORT 		Approved by: Quality Manager
Document S/N: 1M1701180032-01-R4.ZNF	Test Dates: 01/20/17 - 01/30/17	DUT Type: Portable Handset	Page 97 of 97

APPENDIX A: SAR TEST DATA

PCTEST ENGINEERING LABORATORY, INC.

DUT: ZNFH871; Type: Portable Handset; Serial: 08465

Communication System: UID 0, GSM GPRS; 3 Tx slots; Frequency: 836.6 MHz; Duty Cycle: 1:2.76
Medium: 835 Head Medium parameters used (interpolated):
 $f = 836.6$ MHz; $\sigma = 0.89$ S/m; $\epsilon_r = 40.443$; $\rho = 1000$ kg/m³
Phantom section: Left Section

Test Date: 1-30-2017; Ambient Temp: 23.0°C; Tissue Temp: 21.3°C

Probe: ES3DV3 - SN3287; ConvF(6.67, 6.67, 6.67); Calibrated: 9/19/2016;
Sensor-Surface: 3mm (Mechanical Surface Detection)
Electronics: DAE4 Sn1408; Calibrated: 9/14/2016
Phantom: SAM Front; Type: SAM; Serial: 1686
Measurement SW: DASY52, Version 52.8 (8); SEMCAD X Version 14.6.10 (7331)

Mode: GPRS 850, Left Head, Cheek, Mid.ch, 3 Tx slots

Area Scan (9x14x1): Measurement grid: dx=15mm, dy=15mm

Zoom Scan (6x6x7)/Cube 0: Measurement grid: dx=8mm, dy=8mm, dz=5mm

Reference Value = 21.48 V/m; Power Drift = -0.11 dB

Peak SAR (extrapolated) = 0.479 W/kg

SAR(1 g) = 0.376 W/kg

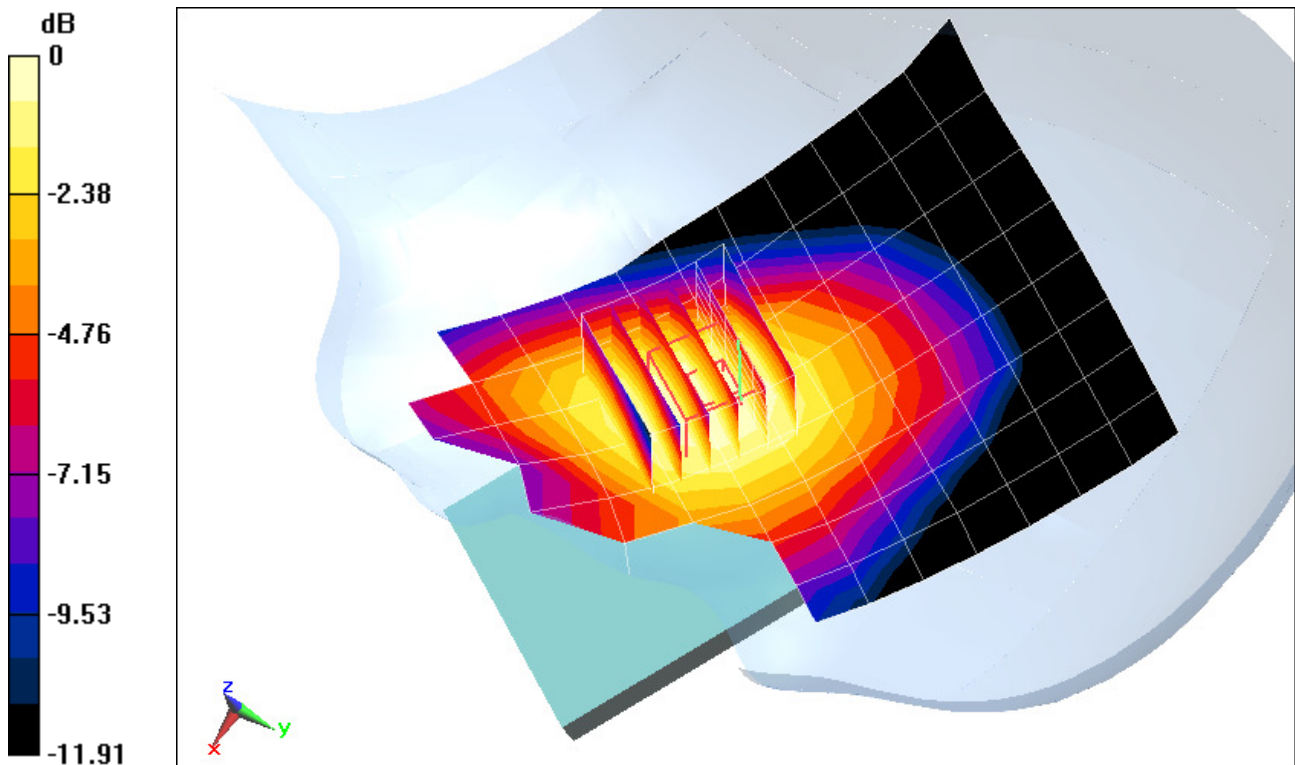

0 dB = 0.404 W/kg = -3.94 dBW/kg

PCTEST ENGINEERING LABORATORY, INC.

DUT: ZNFH871; Type: Portable Handset; Serial: 08465

Communication System: UID 0, UMTS; Frequency: 836.6 MHz; Duty Cycle: 1:1
Medium: 835 Head Medium parameters used (interpolated):
 $f = 836.6 \text{ MHz}$; $\sigma = 0.89 \text{ S/m}$; $\epsilon_r = 40.443$; $\rho = 1000 \text{ kg/m}^3$
Phantom section: Left Section

Test Date: 1-30-2017; Ambient Temp: 23.0°C; Tissue Temp: 21.3°C

Probe: ES3DV3 - SN3287; ConvF(6.67, 6.67, 6.67); Calibrated: 9/19/2016;
Sensor-Surface: 3mm (Mechanical Surface Detection)
Electronics: DAE4 Sn1408; Calibrated: 9/14/2016
Phantom: SAM Front; Type: SAM; Serial: 1686
Measurement SW: DASY52, Version 52.8 (8); SEMCAD X Version 14.6.10 (7331)

Mode: UMTS 850, Left Head, Cheek, Mid.ch

Area Scan (9x14x1): Measurement grid: dx=15mm, dy=15mm

Zoom Scan (5x5x7)/Cube 0: Measurement grid: dx=8mm, dy=8mm, dz=5mm

Reference Value = 8.759 V/m; Power Drift = -0.05 dB

Peak SAR (extrapolated) = 0.0780 W/kg

SAR(1 g) = 0.062 W/kg

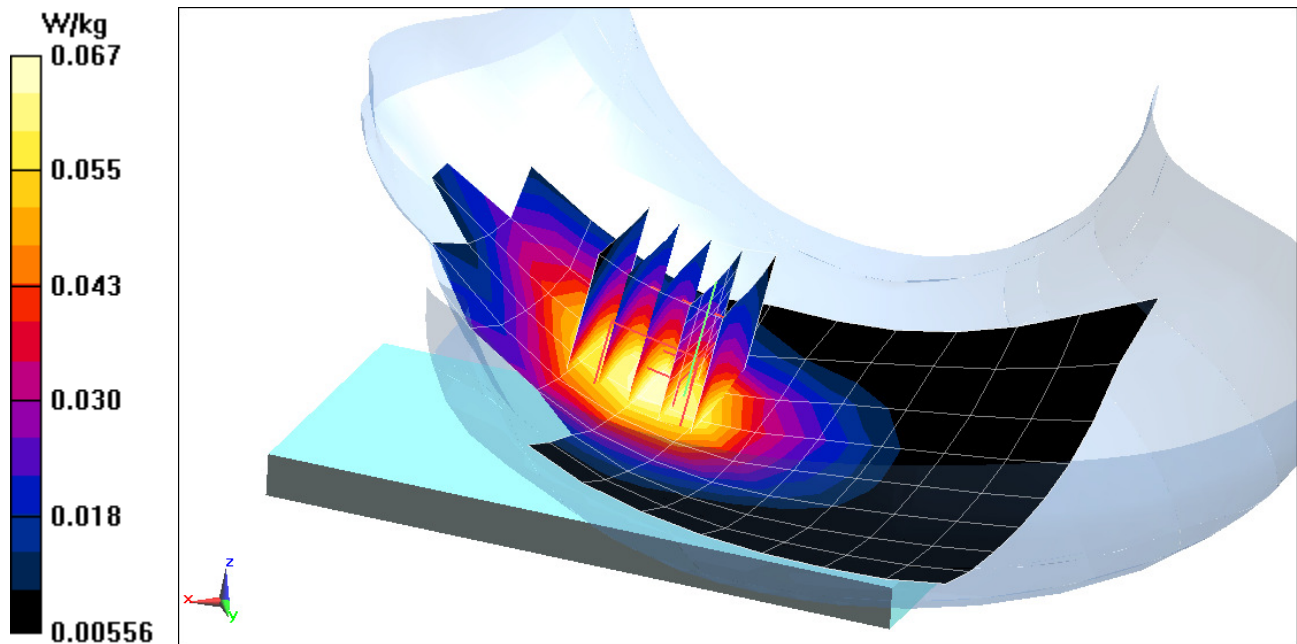

PCTEST ENGINEERING LABORATORY, INC.

DUT: ZNFH871; Type: Portable Handset; Serial: 06440

Communication System: UID 0, UMTS; Frequency: 1732.4 MHz; Duty Cycle: 1:1
Medium: 1750 Head Medium parameters used (interpolated):
 $f = 1732.4 \text{ MHz}$; $\sigma = 1.345 \text{ S/m}$; $\epsilon_r = 38.91$; $\rho = 1000 \text{ kg/m}^3$
Phantom section: Left Section

Test Date: 01-27-2017; Ambient Temp: 24.0°C; Tissue Temp: 23.0°C

Probe: ES3DV3 - SN3209; ConvF(5.28, 5.28, 5.28); Calibrated: 3/18/2016;
Sensor-Surface: 3mm (Mechanical Surface Detection)
Electronics: DAE4 Sn1364; Calibrated: 8/22/2016
Phantom: SAM Front; Type: QD000P40CD; Serial: TP:1758
Measurement SW: DASY52, Version 52.8 (8); SEMCAD X Version 14.6.10 (7331)

Mode: UMTS 1750, Left Head, Cheek, Mid.ch

Area Scan (9x15x1): Measurement grid: dx=15mm, dy=15mm
Zoom Scan (5x5x7)/Cube 0: Measurement grid: dx=8mm, dy=8mm, dz=5mm
Reference Value = 11.56 V/m; Power Drift = 0.00 dB
Peak SAR (extrapolated) = 0.251 W/kg
SAR(1 g) = 0.161 W/kg

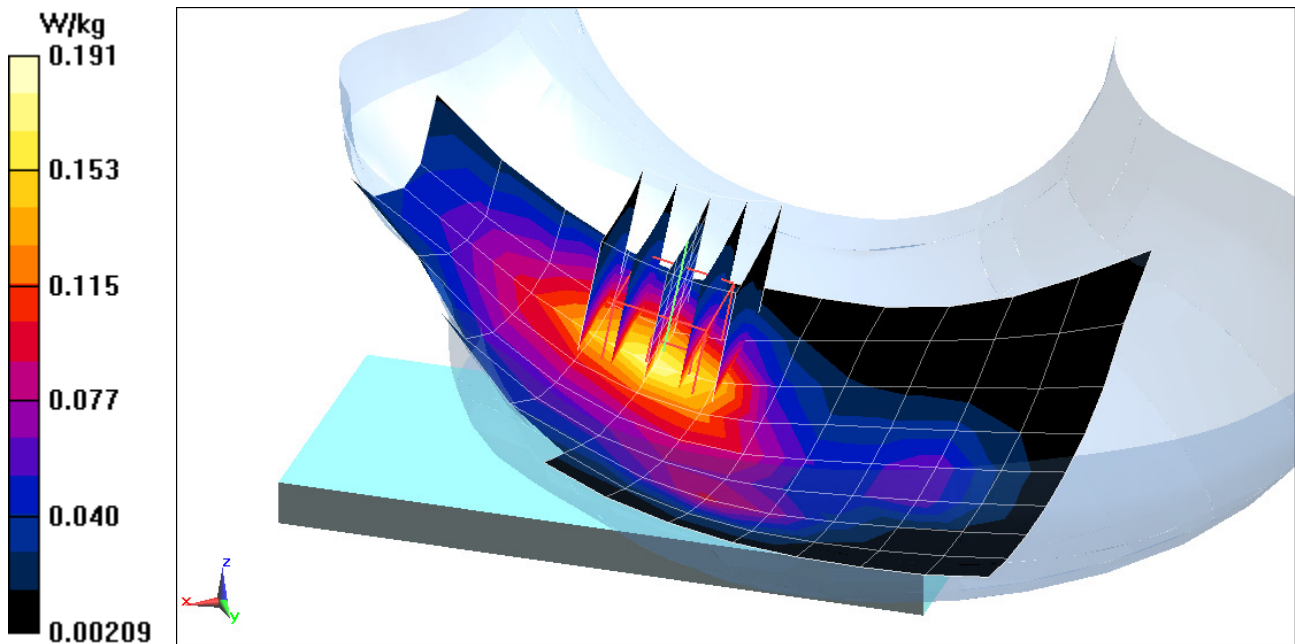

PCTEST ENGINEERING LABORATORY, INC.

DUT: ZNFH871; Type: Portable Handset; Serial: 08473

Communication System: UID 0, GSM GPRS; 3 Tx slots; Frequency: 1880 MHz; Duty Cycle: 1:2.76

Medium: 1900 Head Medium parameters used:

$f = 1880 \text{ MHz}$; $\sigma = 1.43 \text{ S/m}$; $\epsilon_r = 38.258$; $\rho = 1000 \text{ kg/m}^3$

Phantom section: Left Section

Test Date: 01-30-2017; Ambient Temp: 22.5°C; Tissue Temp: 21.5°C

Probe: ES3DV3 - SN3332; ConvF(5.45, 5.45, 5.45); Calibrated: 8/25/2016;

Sensor-Surface: 3mm (Mechanical Surface Detection)

Electronics: DAE4 Sn1333; Calibrated: 9/15/2016

Phantom: SAM Left; Type: SAM; Serial: 1688

Measurement SW: DASY52, Version 52.8 (8); SEMCAD X Version 14.6.10 (7331)

Mode: GPRS 1900, Left Head, Cheek, Mid.ch, 3 Tx slots

Area Scan (9x15x1): Measurement grid: dx=15mm, dy=15mm

Zoom Scan (5x5x7)/Cube 0: Measurement grid: dx=8mm, dy=8mm, dz=5mm

Reference Value = 10.68 V/m; Power Drift = 0.01 dB

Peak SAR (extrapolated) = 0.236 W/kg

SAR(1 g) = 0.146 W/kg

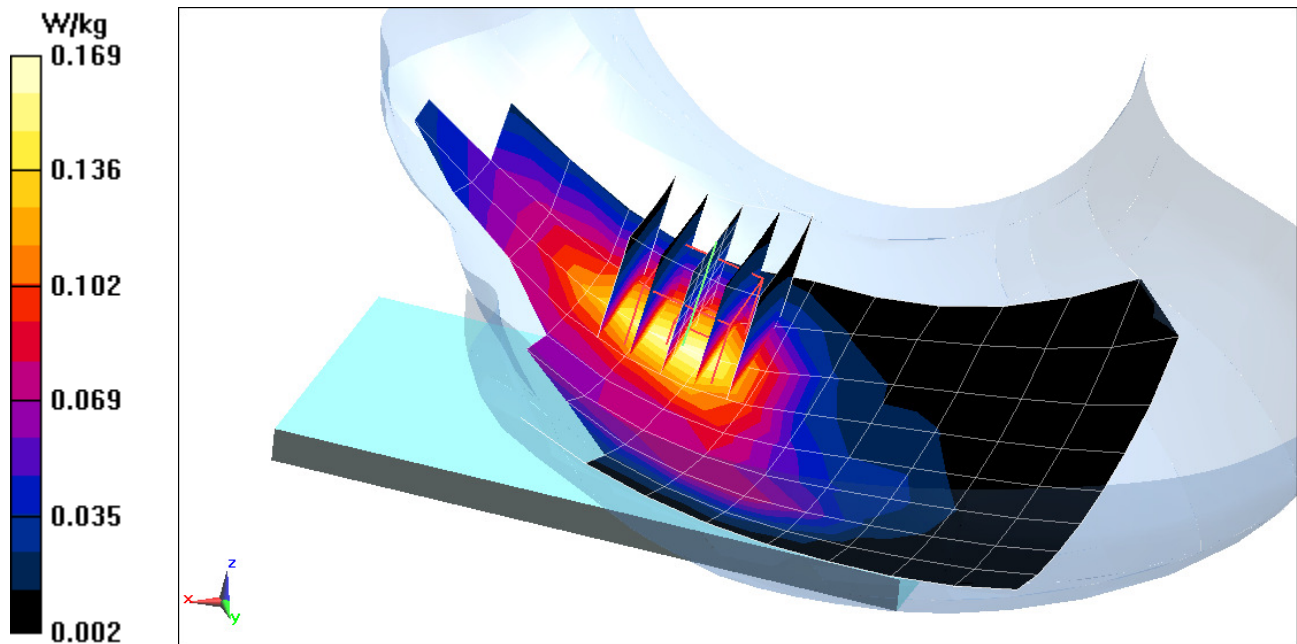

PCTEST ENGINEERING LABORATORY, INC.

DUT: ZNFH871; Type: Portable Handset; Serial: 08465

Communication System: UID 0, UMTS; Frequency: 1880 MHz; Duty Cycle: 1:1
Medium: 1900 Head Medium parameters used:
 $f = 1880 \text{ MHz}$; $\sigma = 1.43 \text{ S/m}$; $\epsilon_r = 38.258$; $\rho = 1000 \text{ kg/m}^3$
Phantom section: Left Section

Test Date: 01-30-2017; Ambient Temp: 22.5°C; Tissue Temp: 21.5°C

Probe: ES3DV3 - SN3332; ConvF(5.45, 5.45, 5.45); Calibrated: 8/25/2016;
Sensor-Surface: 3mm (Mechanical Surface Detection)
Electronics: DAE4 Sn1333; Calibrated: 9/15/2016
Phantom: SAM Left; Type: SAM; Serial: 1688
Measurement SW: DASY52, Version 52.8 (8); SEMCAD X Version 14.6.10 (7331)

Mode: UMTS 1900, Left Head, Cheek, Mid.ch

Area Scan (9x15x1): Measurement grid: dx=15mm, dy=15mm

Zoom Scan (5x5x7)/Cube 0: Measurement grid: dx=8mm, dy=8mm, dz=5mm

Reference Value = 13.46 V/m; Power Drift = 0.04 dB

Peak SAR (extrapolated) = 0.360 W/kg

SAR(1 g) = 0.225 W/kg

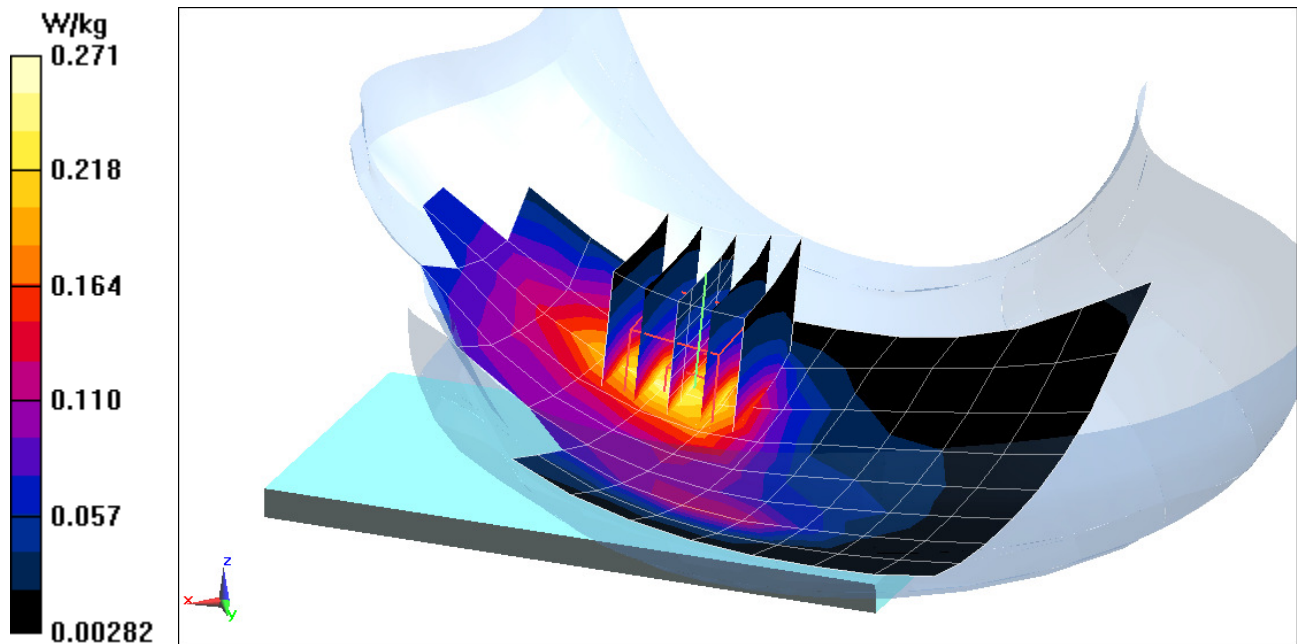

PCTEST ENGINEERING LABORATORY, INC.

DUT: ZNFH871; Type: Portable Handset; Serial: 08523

Communication System: UID 0, LTE Band 12; Frequency: 707.5 MHz; Duty Cycle: 1:1
Medium: 750 Head Medium parameters used (interpolated):
 $f = 707.5$ MHz; $\sigma = 0.866$ S/m; $\epsilon_r = 42.779$; $\rho = 1000$ kg/m³
Phantom section: Left Section

Test Date: 01-25-2017; Ambient Temp: 22.3°C; Tissue Temp: 22.2°C

Probe: ES3DV3 - SN3209; ConvF(6.6, 6.6, 6.6); Calibrated: 3/18/2016;
Sensor-Surface: 3mm (Mechanical Surface Detection)
Electronics: DAE4 Sn1364; Calibrated: 8/22/2016
Phantom: SAM Right; Type: SAM; Serial: 1757

Measurement SW: DASY52, Version 52.8 (8); SEMCAD X Version 14.6.10 (7331)

**Mode: LTE Band 12, Left Head, Cheek, Mid.ch, QPSK,
10 MHz Bandwidth, 1 RB, 0 RB Offset**

Area Scan (9x14x1): Measurement grid: dx=15mm, dy=15mm

Zoom Scan (5x5x7)/Cube 0: Measurement grid: dx=8mm, dy=8mm, dz=5mm

Reference Value = 15.80 V/m; Power Drift = 0.01 dB

Peak SAR (extrapolated) = 0.221 W/kg

SAR(1 g) = 0.186 W/kg

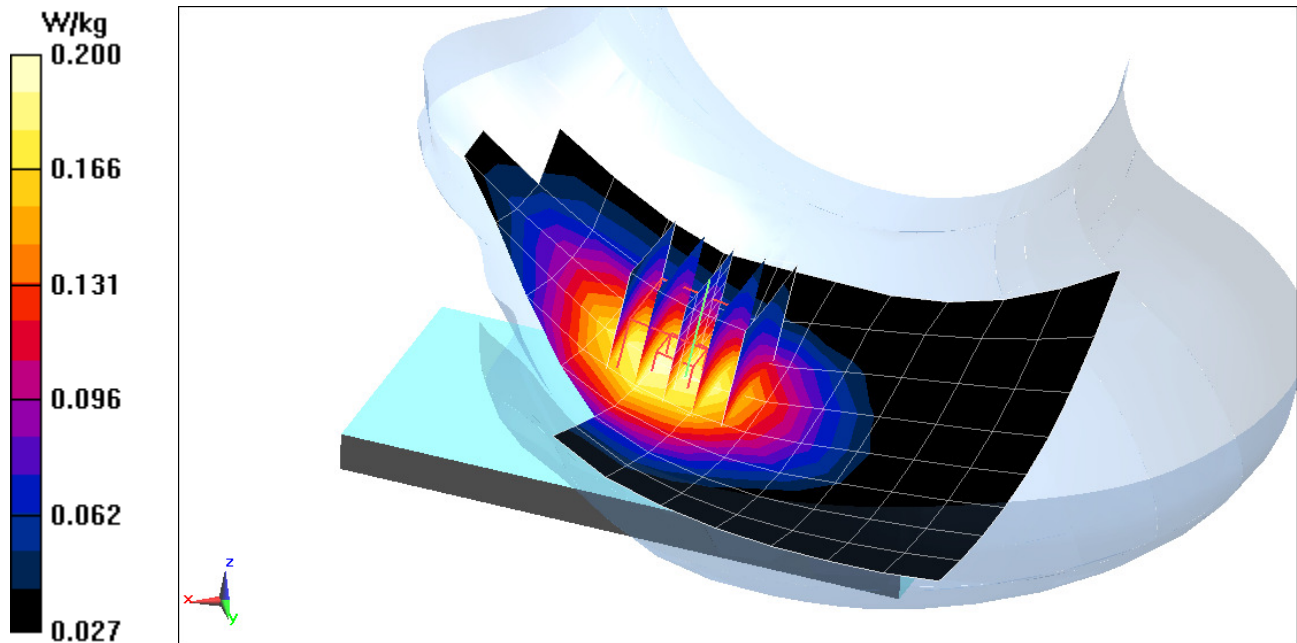

PCTEST ENGINEERING LABORATORY, INC.

DUT: ZNFH871; Type: Portable Handset; Serial: 08523

Communication System: UID 0, LTE Band 13; Frequency: 782 MHz; Duty Cycle: 1:1
Medium: 750 Head Medium parameters used (interpolated):
 $f = 782 \text{ MHz}$; $\sigma = 0.935 \text{ S/m}$; $\epsilon_r = 41.775$; $\rho = 1000 \text{ kg/m}^3$
Phantom section: Left Section

Test Date: 01-25-2017; Ambient Temp: 22.3°C; Tissue Temp: 22.2°C

Probe: ES3DV3 - SN3209; ConvF(6.6, 6.6, 6.6); Calibrated: 3/18/2016;
Sensor-Surface: 3mm (Mechanical Surface Detection)
Electronics: DAE4 Sn1364; Calibrated: 8/22/2016
Phantom: SAM Right; Type: SAM; Serial: 1757

Measurement SW: DASY52, Version 52.8 (8); SEMCAD X Version 14.6.10 (7331)

**Mode: LTE Band 13, Left Head, Cheek, Mid.ch, QPSK,
10 MHz Bandwidth, 1 RB, 0 RB Offset**

Area Scan (9x14x1): Measurement grid: $dx=15\text{mm}$, $dy=15\text{mm}$

Zoom Scan (5x5x7)/Cube 0: Measurement grid: $dx=8\text{mm}$, $dy=8\text{mm}$, $dz=5\text{mm}$

Reference Value = 12.01 V/m; Power Drift = -0.03 dB

Peak SAR (extrapolated) = 0.146 W/kg

SAR(1 g) = 0.116 W/kg

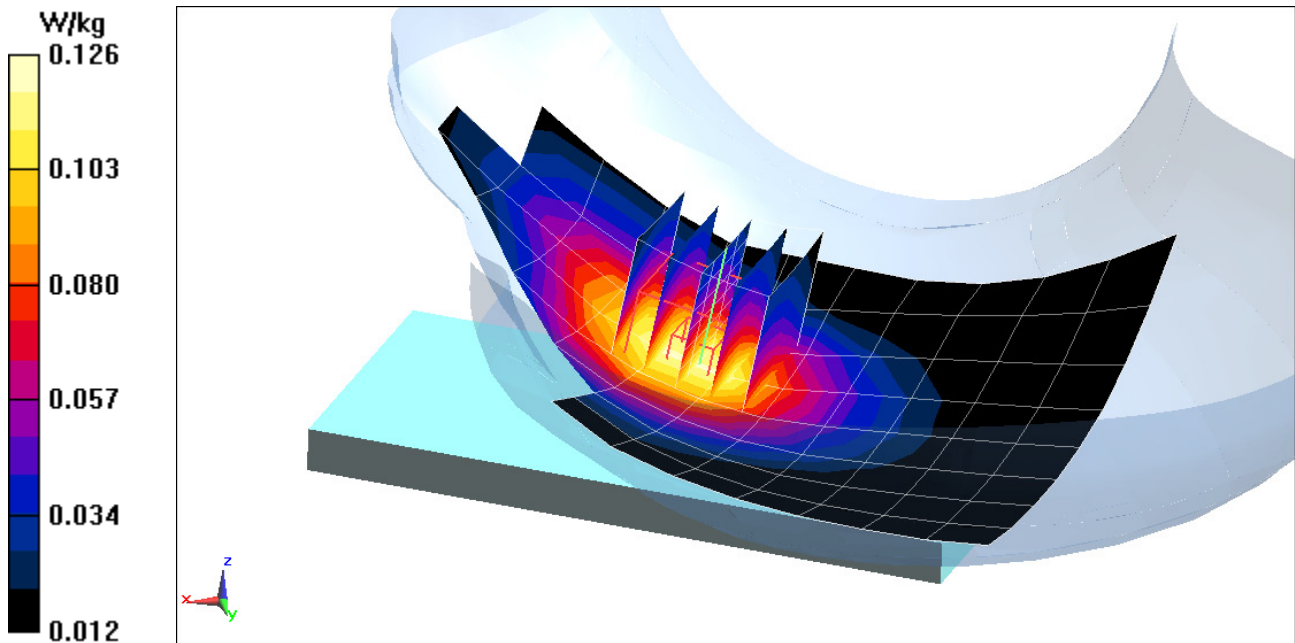

PCTEST ENGINEERING LABORATORY, INC.

DUT: ZNFH871; Type: Portable Handset; Serial: 08516

Communication System: UID 0, LTE Band 5 (Cell.); Frequency: 836.5 MHz; Duty Cycle: 1:1
Medium: 835 Head Medium parameters used (interpolated):
 $f = 836.5 \text{ MHz}$; $\sigma = 0.89 \text{ S/m}$; $\epsilon_r = 40.444$; $\rho = 1000 \text{ kg/m}^3$
Phantom section: Left Section

Test Date: 1-30-2017; Ambient Temp: 23.0°C; Tissue Temp: 21.3°C

Probe: ES3DV3 - SN3287; ConvF(6.67, 6.67, 6.67); Calibrated: 9/19/2016;
Sensor-Surface: 3mm (Mechanical Surface Detection)
Electronics: DAE4 Sn1408; Calibrated: 9/14/2016
Phantom: SAM Front; Type: SAM; Serial: 1686
Measurement SW: DASY52, Version 52.8 (8); SEMCAD X Version 14.6.10 (7331)

**Mode: LTE Band 5 (Cell.), Left Head, Cheek, Mid.ch,
10 MHz Bandwidth, QPSK, 1 RB, 0 RB Offset**

Area Scan (9x14x1): Measurement grid: dx=15mm, dy=15mm
Zoom Scan (5x5x7)/Cube 0: Measurement grid: dx=8mm, dy=8mm, dz=5mm
Reference Value = 16.96 V/m; Power Drift = 0.08 dB
Peak SAR (extrapolated) = 0.302 W/kg
SAR(1 g) = 0.238 W/kg

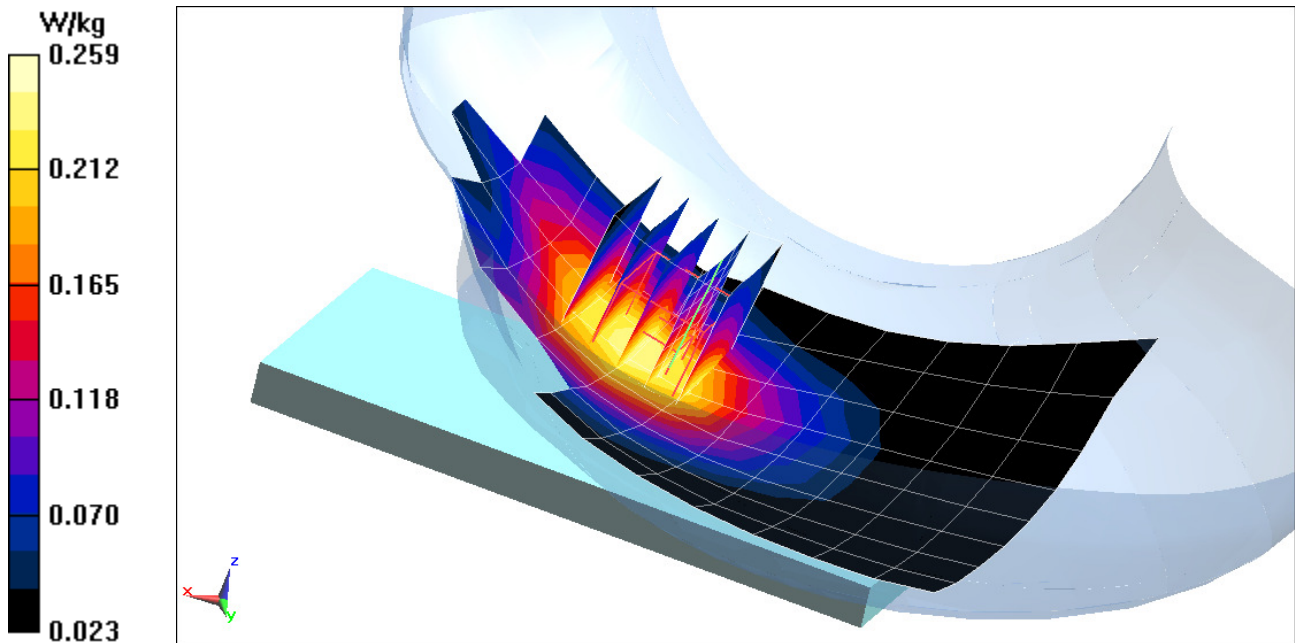

PCTEST ENGINEERING LABORATORY, INC.

DUT: ZNFH871; Type: Portable Handset; Serial: 08440

Communication System: UID 0, LTE Band 66 (AWS); Frequency: 1720 MHz; Duty Cycle: 1:1
Medium: 1750 Head Medium parameters used (interpolated):
 $f = 1720 \text{ MHz}$; $\sigma = 1.334 \text{ S/m}$; $\epsilon_r = 38.973$; $\rho = 1000 \text{ kg/m}^3$
Phantom section: Left Section

Test Date: 01-27-2017; Ambient Temp: 24.0°C; Tissue Temp: 23.0°C

Probe: ES3DV3 - SN3209; ConvF(5.28, 5.28, 5.28); Calibrated: 3/18/2016;
Sensor-Surface: 3mm (Mechanical Surface Detection)
Electronics: DAE4 Sn1364; Calibrated: 8/22/2016
Phantom: SAM Front; Type: QD000P40CD; Serial: TP:1758
Measurement SW: DASY52, Version 52.8 (8); SEMCAD X Version 14.6.10 (7331)

**Mode: LTE Band 66 (AWS), Left Head, Cheek, Low.ch,
20 MHz Bandwidth, QPSK, 1 RB, 99 RB Offset**

Area Scan (9x15x1): Measurement grid: dx=15mm, dy=15mm

Zoom Scan (5x5x7)/Cube 0: Measurement grid: dx=8mm, dy=8mm, dz=5mm

Reference Value = 13.68 V/m; Power Drift = 0.13 dB

Peak SAR (extrapolated) = 0.363 W/kg

SAR(1 g) = 0.228 W/kg

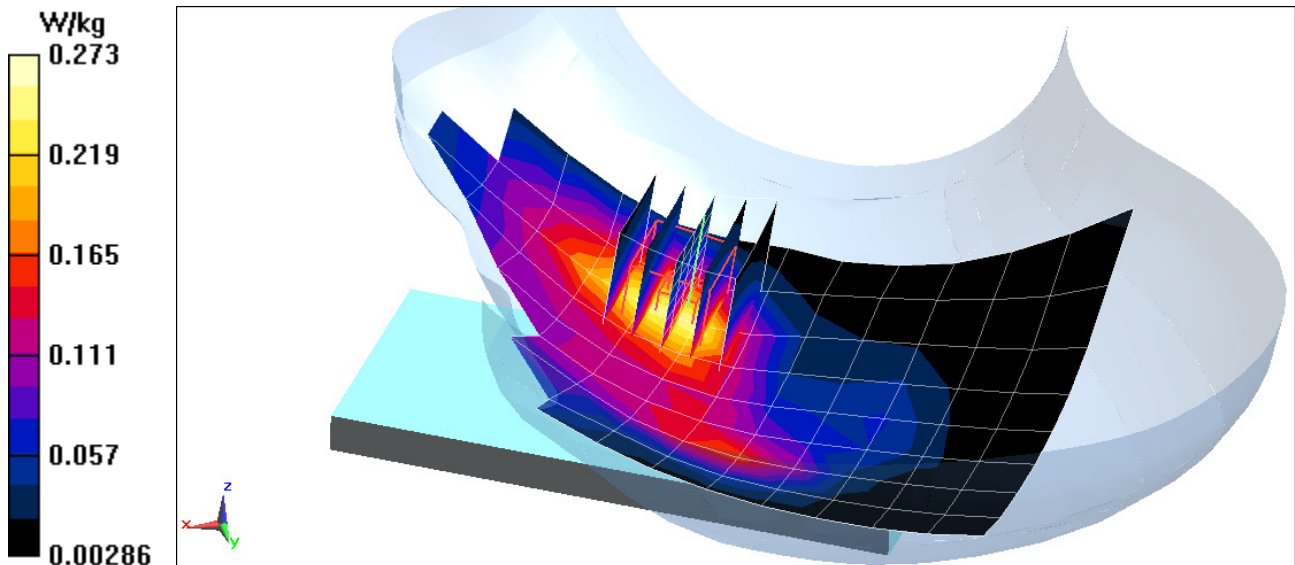

PCTEST ENGINEERING LABORATORY, INC.

DUT: ZNFH871; Type: Portable Handset; Serial: 08457

Communication System: UID 0, LTE Band 25 (PCS); Frequency: 1882.5 MHz; Duty Cycle: 1:1
Medium: 1900 Head Medium parameters used (interpolated):
 $f = 1882.5 \text{ MHz}$; $\sigma = 1.44 \text{ S/m}$; $\epsilon_r = 40.17$; $\rho = 1000 \text{ kg/m}^3$
Phantom section: Left Section

Test Date: 01-24-2017; Ambient Temp: 22.7°C; Tissue Temp: 22.5°C

Probe: ES3DV3 - SN3332; ConvF(5.45, 5.45, 5.45); Calibrated: 8/25/2016;
Sensor-Surface: 3mm (Mechanical Surface Detection)
Electronics: DAE4 Sn1333; Calibrated: 9/15/2016
Phantom: SAM Left; Type: SAM; Serial: 1688
Measurement SW: DASY52, Version 52.8 (8); SEMCAD X Version 14.6.10 (7331)

**Mode: LTE Band 25 (PCS), Left Head, Cheek, Mid.ch,
20 MHz Bandwidth, QPSK, 1 RB, 0 RB Offset**

Area Scan (7x14x1): Measurement grid: dx=15mm, dy=15mm
Zoom Scan (5x5x7)/Cube 0: Measurement grid: dx=8mm, dy=8mm, dz=5mm
Reference Value = 13.28 V/m; Power Drift = -0.01 dB
Peak SAR (extrapolated) = 0.342 W/kg
SAR(1 g) = 0.209 W/kg

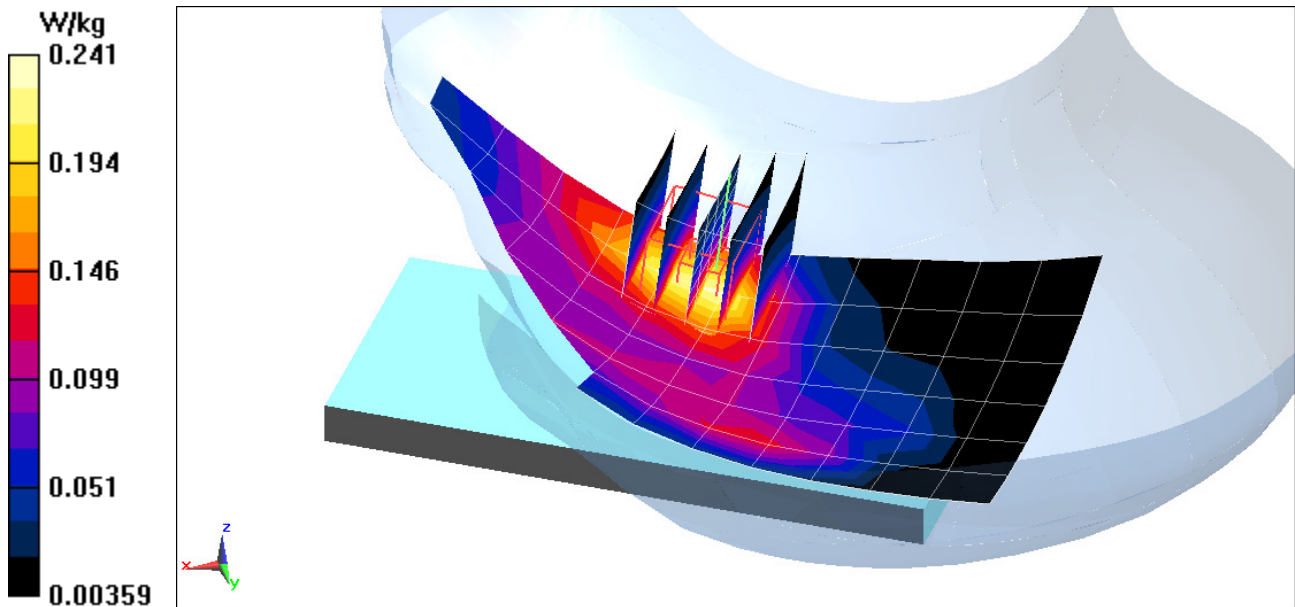

PCTEST ENGINEERING LABORATORY, INC.

DUT: ZNFH871; Type: Portable Handset; Serial: 08515

Communication System: UID 0, LTE Band 30; Frequency: 2310 MHz; Duty Cycle: 1:1

Medium: 2300 Head Medium parameters used:

$f = 2310$ MHz; $\sigma = 1.708$ S/m; $\epsilon_r = 38.758$; $\rho = 1000$ kg/m³

Phantom section: Right Section

Test Date: 01-22-2017; Ambient Temp: 23.2°C; Tissue Temp: 22.5°C

Probe: ES3DV3 - SN3287; ConvF(4.86, 4.86, 4.86); Calibrated: 9/19/2016;

Sensor-Surface: 3mm (Mechanical Surface Detection)

Electronics: DAE4 Sn1408; Calibrated: 9/14/2016

Phantom: SAM Front; Type: SAM; Serial: 1686

Measurement SW: DASY52, Version 52.8 (8); SEMCAD X Version 14.6.10 (7331)

**Mode: LTE Band 30, Right Head, Cheek, Mid.ch,
10 MHz Bandwidth, QPSK, 1 RB, 0 RB Offset**

Area Scan (11x17x1): Measurement grid: dx=12mm, dy=12mm

Zoom Scan (8x7x7)/Cube 0: Measurement grid: dx=5mm, dy=5mm, dz=5mm

Reference Value = 8.339 V/m; Power Drift = 0.13 dB

Peak SAR (extrapolated) = 0.148 W/kg

SAR(1 g) = 0.094 W/kg

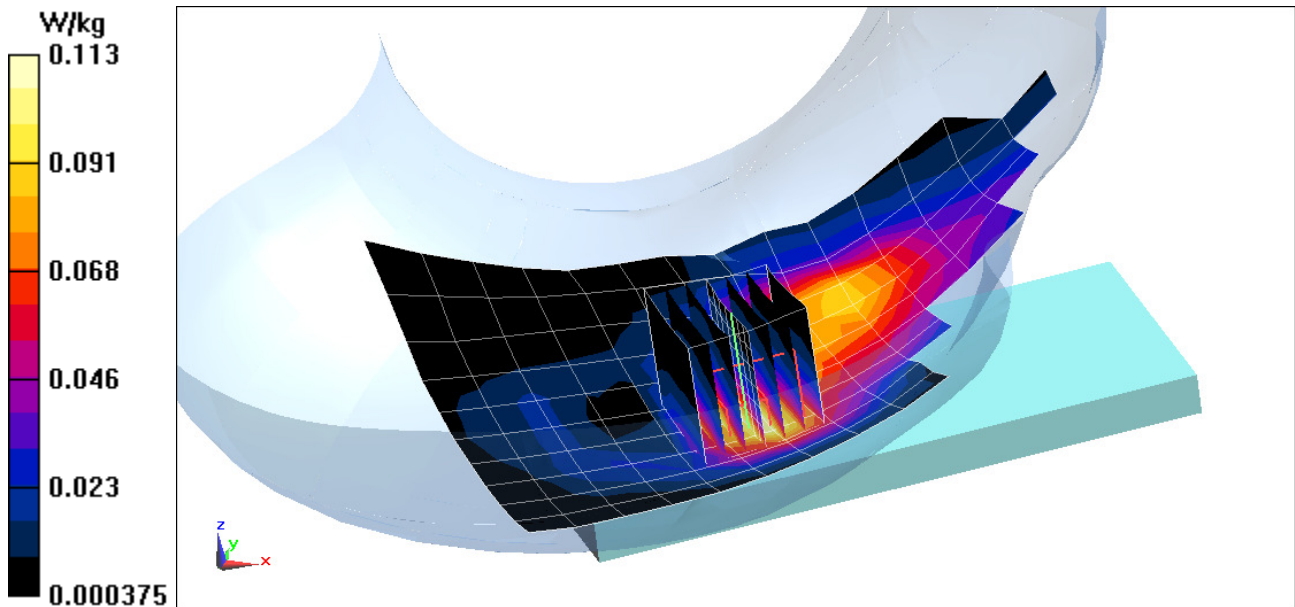

PCTEST ENGINEERING LABORATORY, INC.

DUT: ZNFH871; Type: Portable Handset; Serial: 08523

Communication System: UID 0, LTE Band 7; Frequency: 2560 MHz; Duty Cycle: 1:1
Medium: 2600 Head Medium parameters used (interpolated):
 $f = 2560$ MHz; $\sigma = 1.996$ S/m; $\epsilon_r = 37.699$; $\rho = 1000$ kg/m³
Phantom section: Left Section

Test Date: 01-22-2017; Ambient Temp: 23.2°C; Tissue Temp: 22.5°C

Probe: ES3DV3 - SN3287; ConvF(4.41, 4.41, 4.41); Calibrated: 9/19/2016;
Sensor-Surface: 3mm (Mechanical Surface Detection)
Electronics: DAE4 Sn1408; Calibrated: 9/14/2016
Phantom: SAM Front; Type: SAM; Serial: 1686
Measurement SW: DASY52, Version 52.8 (8); SEMCAD X Version 14.6.10 (7331)

**Mode: LTE Band 7, Left Head, Cheek, High.ch, QPSK,
20 MHz Bandwidth, 1 RB, 0 RB Offset**

Area Scan (11x18x1): Measurement grid: dx=12mm, dy=12mm
Zoom Scan (7x7x7)/Cube 0: Measurement grid: dx=5mm, dy=5mm, dz=5mm
Reference Value = 7.079 V/m; Power Drift = 0.12 dB
Peak SAR (extrapolated) = 0.155 W/kg
SAR(1 g) = 0.079 W/kg

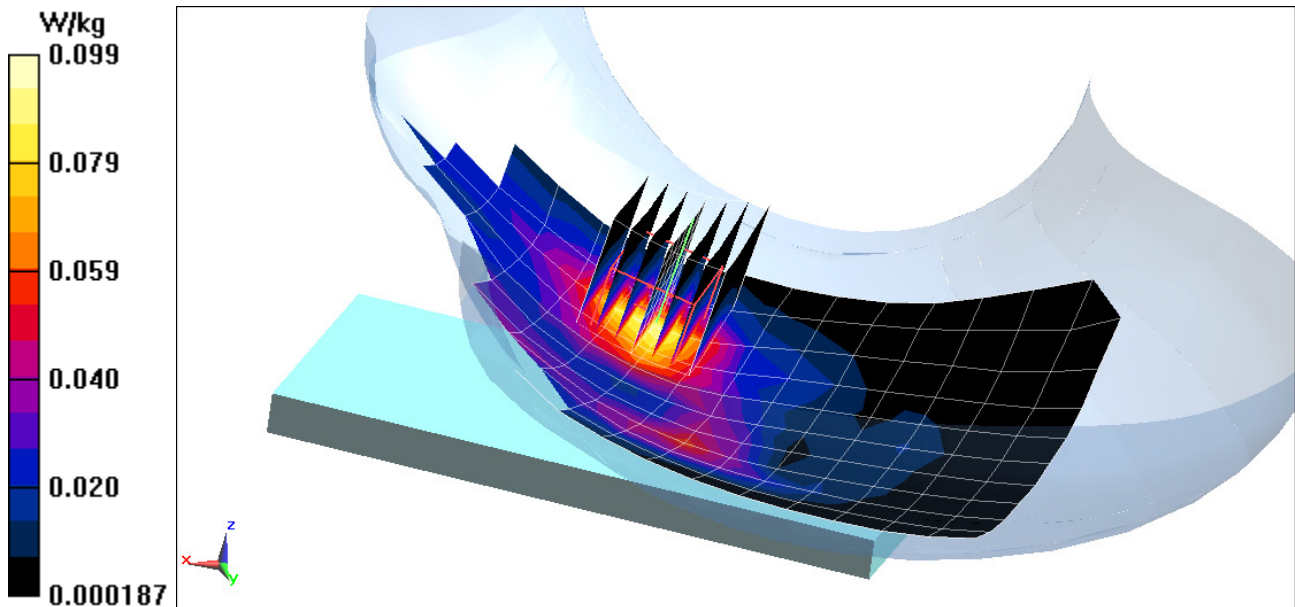

PCTEST ENGINEERING LABORATORY, INC.

DUT: ZNFH871; Type: Portable Handset; Serial: 08564

Communication System: UID 0, IEEE 802.11b; Frequency: 2437 MHz; Duty Cycle: 1:1
Medium: 2450 Head Medium parameters used (interpolated):
 $f = 2437 \text{ MHz}$; $\sigma = 1.865 \text{ S/m}$; $\epsilon_r = 39.469$; $\rho = 1000 \text{ kg/m}^3$
Phantom section: Right Section

Test Date: 01-20-2017; Ambient Temp: 24.1°C; Tissue Temp: 23.1°C

Probe: ES3DV3 - SN3287; ConvF(4.54, 4.54, 4.54); Calibrated: 9/19/2016;
Sensor-Surface: 3mm (Mechanical Surface Detection)
Electronics: DAE4 Sn1408; Calibrated: 9/14/2016
Phantom: SAM Front; Type: SAM; Serial: 1686
Measurement SW: DASY52, Version 52.8 (8); SEMCAD X Version 14.6.10 (7331)

Mode: IEEE 802.11b, 22 MHz Bandwidth, Right Head, Cheek, Ch 6, 1 Mbps, Secondary Ant

Area Scan (11x18x1): Measurement grid: dx=12mm, dy=12mm
Zoom Scan (8x7x7)/Cube 0: Measurement grid: dx=5mm, dy=5mm, dz=5mm
Reference Value = 29.30 V/m; Power Drift = -0.14 dB
Peak SAR (extrapolated) = 1.62 W/kg
SAR(1 g) = 0.666 W/kg

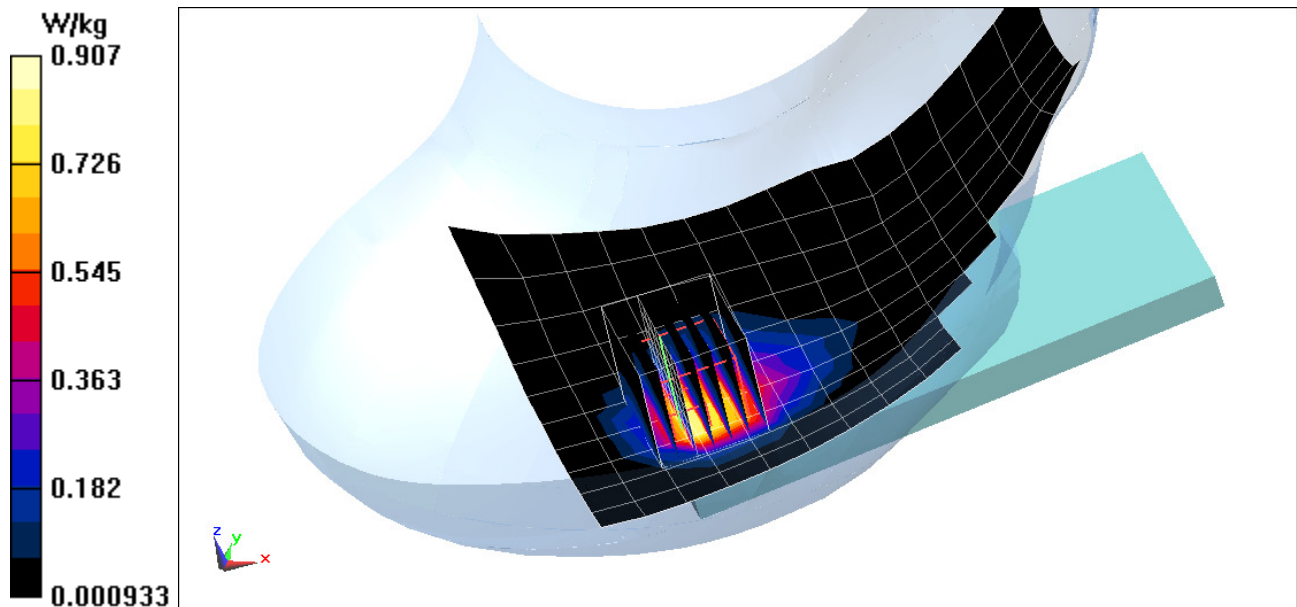

PCTEST ENGINEERING LABORATORY, INC.

DUT: ZNFH871; Type: Portable Handset; Serial: 08564

Communication System: UID 0, 802.11a 5.2-5.8 GHz Band; Frequency: 5260 MHz; Duty Cycle: 1:1

Medium: 5 GHz Head Medium parameters used:

$f = 5260 \text{ MHz}$; $\sigma = 4.59 \text{ S/m}$; $\epsilon_r = 34.983$; $\rho = 1000 \text{ kg/m}^3$

Phantom section: Right Section

Test Date: 01-23-2017; Ambient Temp: 20.9°C; Tissue Temp: 20.3°C

Probe: EX3DV4 - SN7357; ConvF(5.1, 5.1, 5.1); Calibrated: 4/19/2016;

Sensor-Surface: 1.4mm (Mechanical Surface Detection)

Electronics: DAE4 Sn665; Calibrated: 2/19/2016

Phantom: SAM with CRP v4.0; Type: QD000P40CD; Serial: TP:1800

Measurement SW: DASY52, Version 52.8 (8); SEMCAD X Version 14.6.10 (7331)

**Mode: IEEE 802.11a, U-NII-2A, 20 MHz Bandwidth, Right Head, Cheek,
Ch 52, 6 Mbps, Secondary Ant**

Area Scan (13x22x1): Measurement grid: dx=10mm, dy=10mm

Zoom Scan (7x7x7)/Cube 0: Measurement grid: dx=4mm, dy=4mm, dz=1.4mm; Graded Ratio: 1.4

Reference Value = 0 V/m; Power Drift = 0.10 dB

Peak SAR (extrapolated) = 2.98 W/kg

SAR(1 g) = 0.634 W/kg

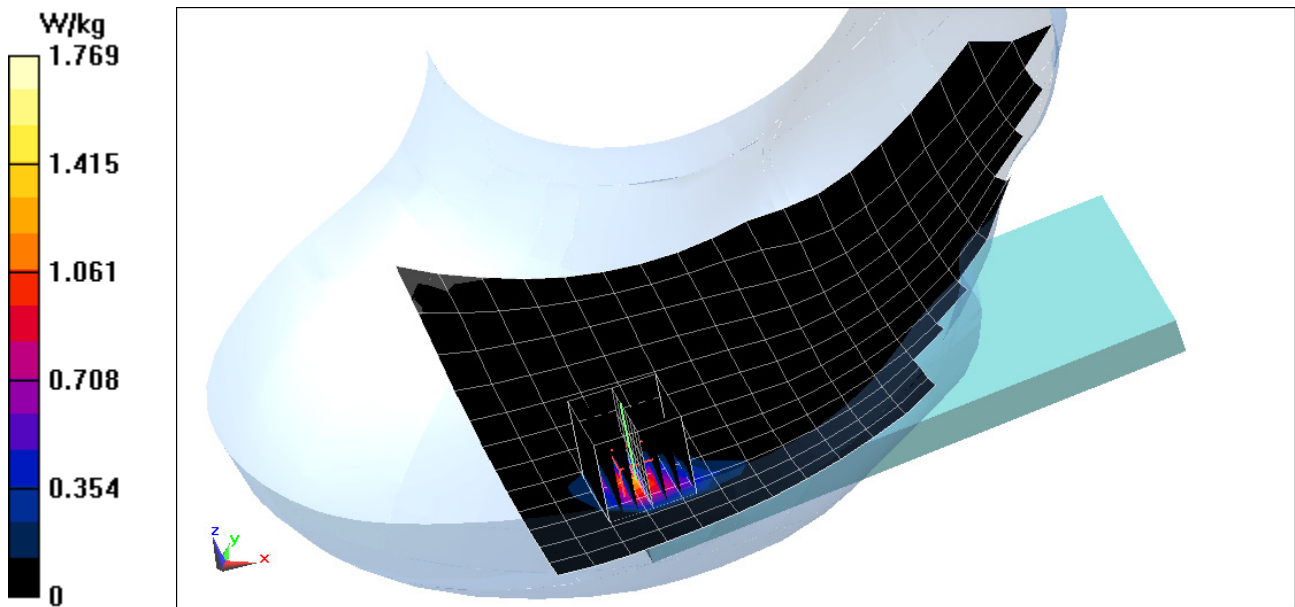

PCTEST ENGINEERING LABORATORY, INC.

DUT: ZNFH871; Type: Portable Handset; Serial: 08465

Communication System: UID 0, GSM GPRS; 3 Tx slots; Frequency: 848.8 MHz; Duty Cycle: 1:2.76
Medium: 835 Body Medium parameters used (interpolated):
 $f = 848.8 \text{ MHz}$; $\sigma = 1.017 \text{ S/m}$; $\epsilon_r = 55.371$; $\rho = 1000 \text{ kg/m}^3$
Phantom section: Flat Section; Space: 1.0 cm

Test Date: 01-30-2017; Ambient Temp: 22.8°C; Tissue Temp: 21.1°C

Probe: ES3DV3 - SN3319; ConvF(6.04, 6.04, 6.04); Calibrated: 3/18/2016;
Sensor-Surface: 3mm (Mechanical Surface Detection)
Electronics: DAE4 Sn1368; Calibrated: 3/14/2016
Phantom: SAM with CRP (Left); Type: SAM; Serial: 1715
Measurement SW: DASY52, Version 52.8 (8); SEMCAD X Version 14.6.10 (7331)

Mode: GPRS 850, Body SAR, Back side, High.ch, 3 Tx Slots

Area Scan (9x15x1): Measurement grid: dx=15mm, dy=15mm
Zoom Scan (5x5x7)/Cube 0: Measurement grid: dx=8mm, dy=8mm, dz=5mm
Reference Value = 32.32 V/m; Power Drift = 0.00 dB
Peak SAR (extrapolated) = 1.40 W/kg
SAR(1 g) = 0.989 W/kg

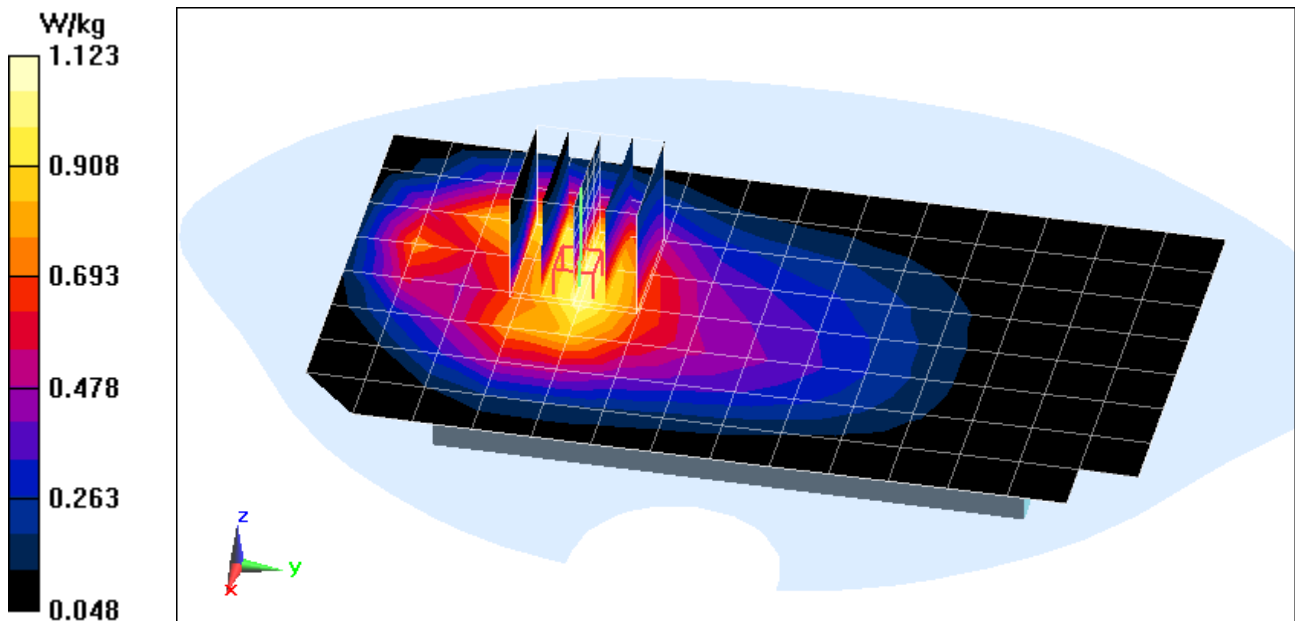

PCTEST ENGINEERING LABORATORY, INC.

DUT: ZNFH871; Type: Portable Handset; Serial: 08465

Communication System: UID 0, GSM GPRS; 3 Tx slots; Frequency: 836.6 MHz; Duty Cycle: 1:2.76
Medium: 835 Body Medium parameters used (interpolated):
 $f = 836.6$ MHz; $\sigma = 1.001$ S/m; $\epsilon_r = 55.505$; $\rho = 1000$ kg/m³
Phantom section: Flat Section; Space: 1.0 cm

Test Date: 01-30-2017; Ambient Temp: 22.8°C; Tissue Temp: 21.1°C

Probe: ES3DV3 - SN3319; ConvF(6.04, 6.04, 6.04); Calibrated: 3/18/2016;
Sensor-Surface: 3mm (Mechanical Surface Detection)
Electronics: DAE4 Sn1368; Calibrated: 3/14/2016
Phantom: SAM with CRP (Left); Type: SAM; Serial: 1715
Measurement SW: DASY52, Version 52.8 (8); SEMCAD X Version 14.6.10 (7331)

Mode: GPRS 850, Body SAR, Front side, Mid.ch, 3 Tx Slots

Area Scan (9x15x1): Measurement grid: dx=15mm, dy=15mm
Zoom Scan (5x5x7)/Cube 0: Measurement grid: dx=8mm, dy=8mm, dz=5mm
Reference Value = 33.83 V/m; Power Drift = -0.18 dB
Peak SAR (extrapolated) = 1.55 W/kg
SAR(1 g) = 1.06 W/kg

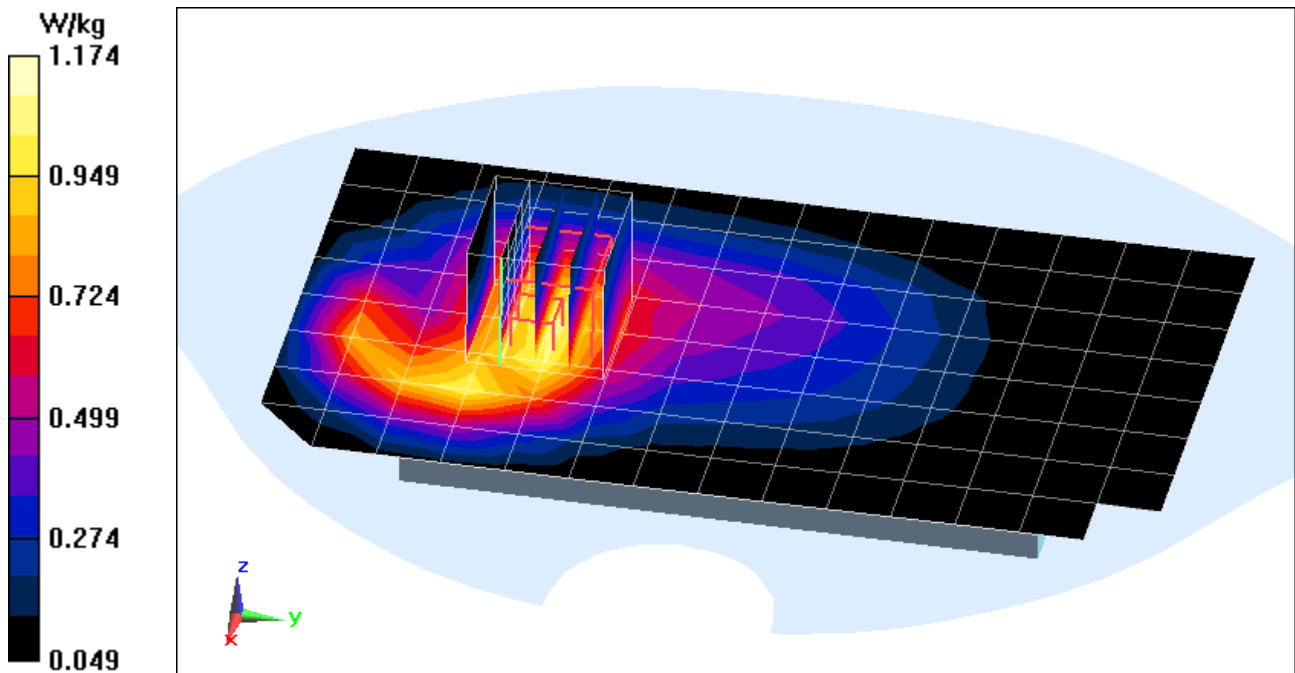

PCTEST ENGINEERING LABORATORY, INC.

DUT: ZNFH871; Type: Portable Handset; Serial: 08465

Communication System: UID 0, UMTS; Frequency: 836.6 MHz; Duty Cycle: 1:1
Medium: 835 Body Medium parameters used (interpolated):
 $f = 836.6 \text{ MHz}$; $\sigma = 1.001 \text{ S/m}$; $\epsilon_r = 55.505$; $\rho = 1000 \text{ kg/m}^3$
Phantom section: Flat Section; Space: 1.0 cm

Test Date: 01-30-2017; Ambient Temp: 22.8°C; Tissue Temp: 21.1°C

Probe: ES3DV3 - SN3319; ConvF(6.04, 6.04, 6.04); Calibrated: 3/18/2016;
Sensor-Surface: 3mm (Mechanical Surface Detection)
Electronics: DAE4 Sn1368; Calibrated: 3/14/2016
Phantom: SAM with CRP (Left); Type: SAM; Serial: 1715
Measurement SW: DASY52, Version 52.8 (8); SEMCAD X Version 14.6.10 (7331)

Mode: UMTS 850, Body SAR, Back side, Mid.ch

Area Scan (8x14x1): Measurement grid: $dx=15\text{mm}$, $dy=15\text{mm}$

Zoom Scan (6x6x7)/Cube 0: Measurement grid: $dx=8\text{mm}$, $dy=8\text{mm}$, $dz=5\text{mm}$

Reference Value = 16.71 V/m; Power Drift = -0.02 dB

Peak SAR (extrapolated) = 0.377 W/kg

SAR(1 g) = 0.254 W/kg

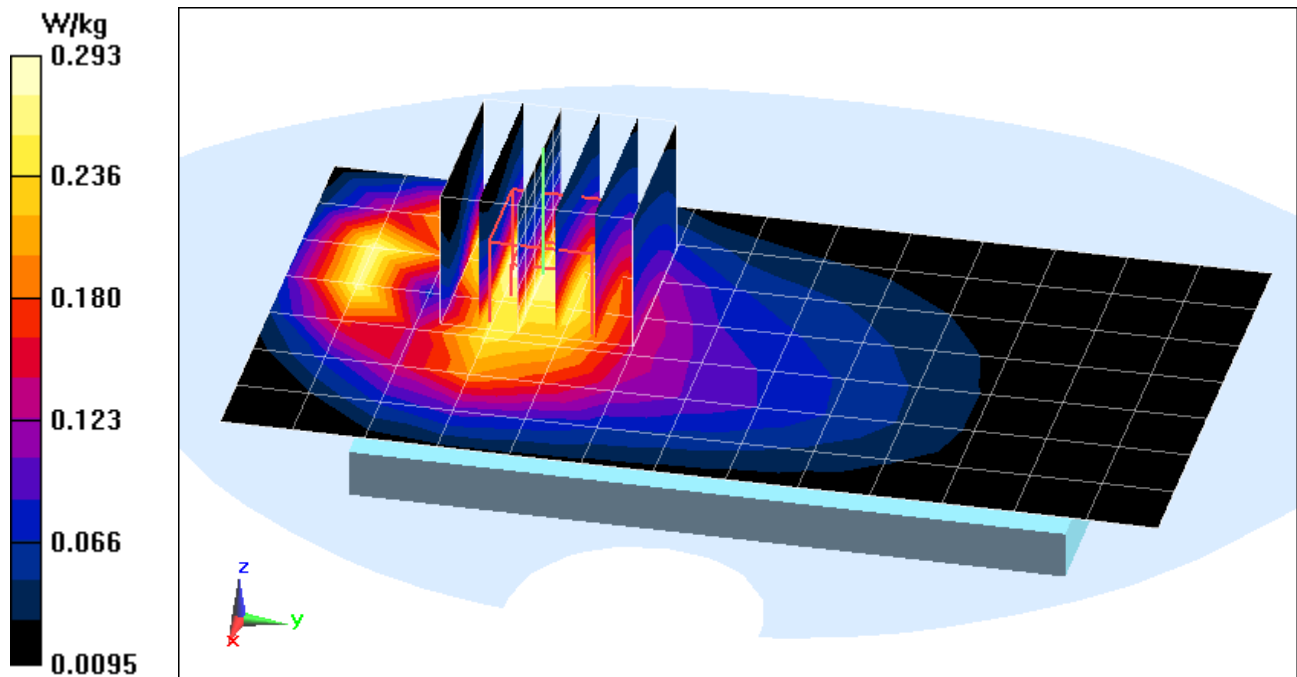

PCTEST ENGINEERING LABORATORY, INC.

DUT: ZNFH871; Type: Portable Handset; Serial: 08473

Communication System: UID 0, UMTS; Frequency: 1752.6 MHz; Duty Cycle: 1:1
Medium: 1750 Body Medium parameters used (interpolated):
 $f = 1752.6 \text{ MHz}$; $\sigma = 1.509 \text{ S/m}$; $\epsilon_r = 51.562$; $\rho = 1000 \text{ kg/m}^3$
Phantom section: Flat Section; Space: 1.0 cm

Test Date: 01-23-2017; Ambient Temp: 23.6°C; Tissue Temp: 23.0°C

Probe: ES3DV3 - SN3209; ConvF(4.99, 4.99, 4.99); Calibrated: 3/18/2016;
Sensor-Surface: 3mm (Mechanical Surface Detection)
Electronics: DAE4 Sn1364; Calibrated: 8/22/2016
Phantom: SAM Front; Type: QD000P40CD; Serial: TP:1758
Measurement SW: DASY52, Version 52.8 (8); SEMCAD X Version 14.6.10 (7331)

Mode: UMTS 1750, Body SAR, Back side, High.ch

Area Scan (9x15x1): Measurement grid: dx=15mm, dy=15mm
Zoom Scan (5x5x7)/Cube 0: Measurement grid: dx=8mm, dy=8mm, dz=5mm
Reference Value = 26.27 V/m; Power Drift = 0.05 dB
Peak SAR (extrapolated) = 1.43 W/kg
SAR(1 g) = 0.936 W/kg

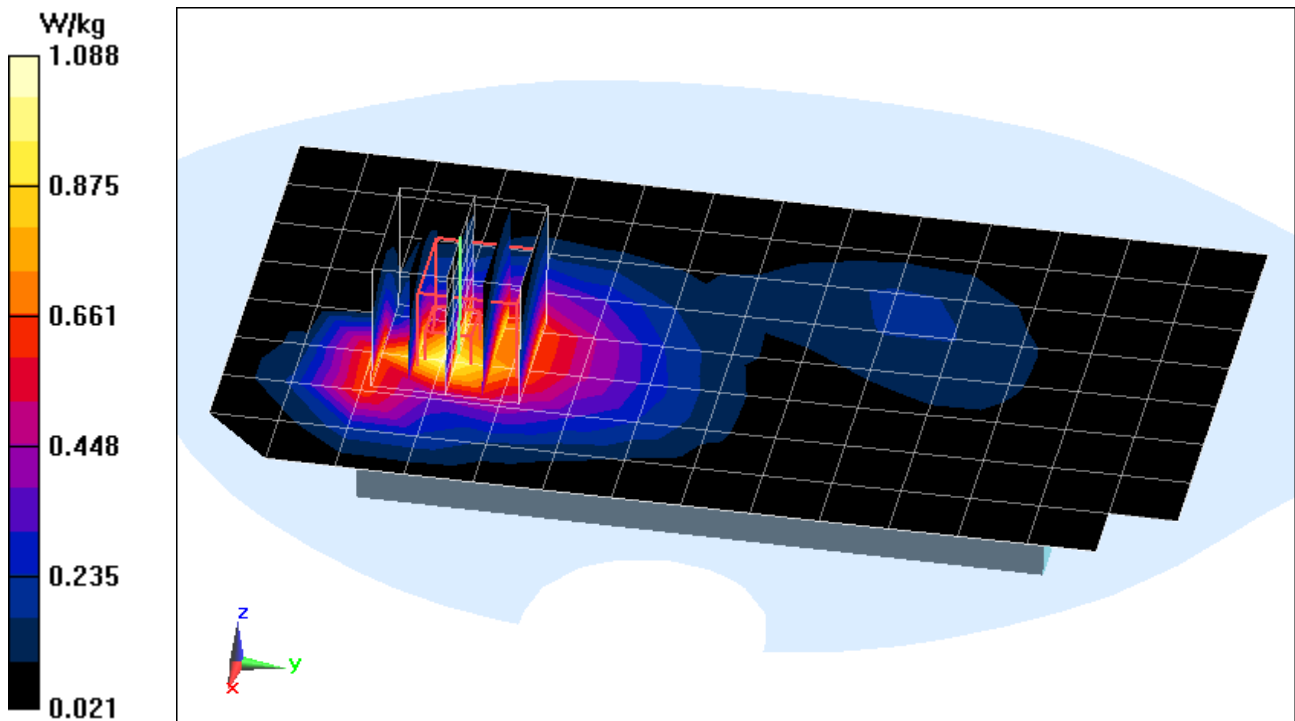

PCTEST ENGINEERING LABORATORY, INC.

DUT: ZNFH871; Type: Portable Handset; Serial: 08465

Communication System: UID 0, GSM GPRS; 3 Tx slots; Frequency: 1880 MHz; Duty Cycle: 1:2.76

Medium: 1900 Body Medium parameters used:

$f = 1880 \text{ MHz}$; $\sigma = 1.536 \text{ S/m}$; $\epsilon_r = 52.21$; $\rho = 1000 \text{ kg/m}^3$

Phantom section: Flat Section; Space: 1.0 cm

Test Date: 1-25-2017; Ambient Temp: 24.0°C; Tissue Temp: 21.5°C

Probe: EX3DV4 - SN7409; ConvF(7.47, 7.47, 7.47); Calibrated: 5/17/2016;

Sensor-Surface: 1.4mm (Mechanical Surface Detection)

Electronics: DAE4 Sn859; Calibrated: 5/11/2016

Phantom: SAM Left; Type: QD000P40CC; Serial: TP: 1375

Measurement SW: DASY52, Version 52.8 (8); SEMCAD X Version 14.6.10 (7331)

Mode: GPRS 1900, Body SAR, Back side, Mid.ch, 3 Tx Slots

Area Scan (9x15x1): Measurement grid: dx=15mm, dy=15mm

Zoom Scan (6x6x7)/Cube 0: Measurement grid: dx=8mm, dy=8mm, dz=5mm

Reference Value = 15.11 V/m; Power Drift = 0.00 dB

Peak SAR (extrapolated) = 0.578 W/kg

SAR(1 g) = 0.316 W/kg

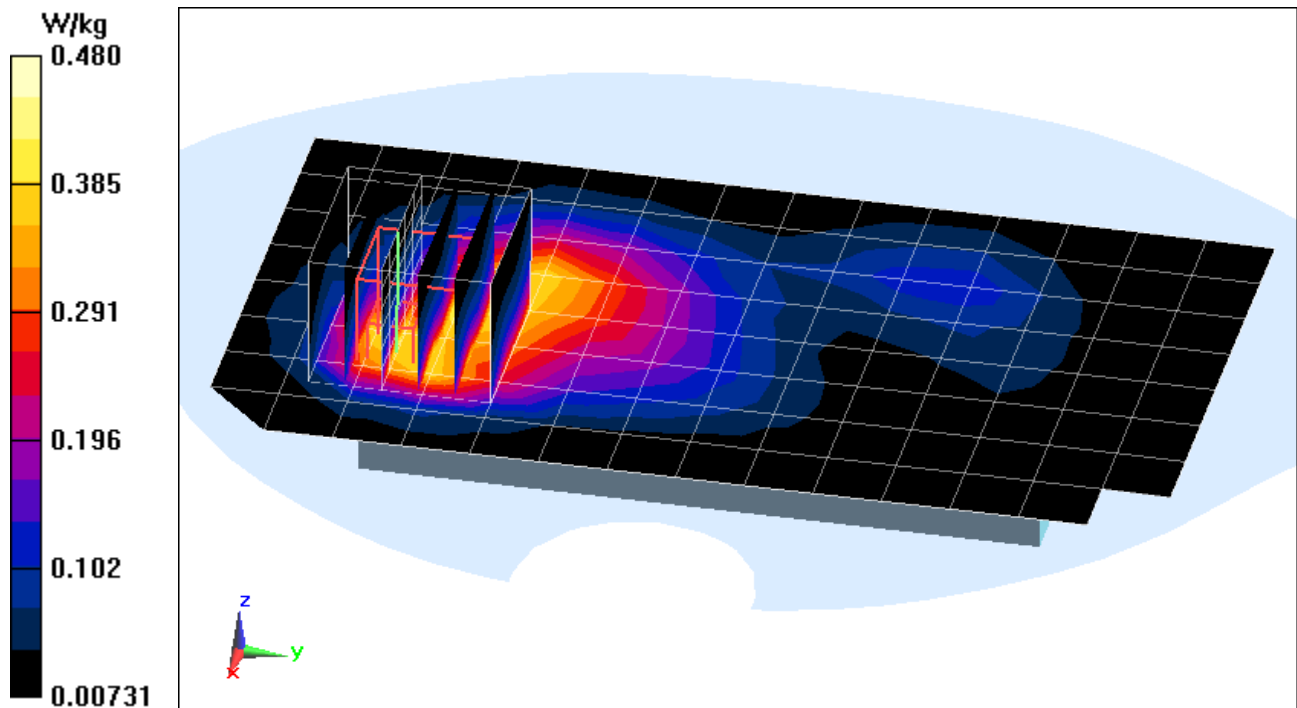

PCTEST ENGINEERING LABORATORY, INC.

DUT: ZNFH871; Type: Portable Handset; Serial: 08465

Communication System: UID 0, GSM GPRS; 3 Tx slots; Frequency: 1880 MHz; Duty Cycle: 1:2.76

Medium: 1900 Body Medium parameters used:

$f = 1880 \text{ MHz}$; $\sigma = 1.536 \text{ S/m}$; $\epsilon_r = 52.21$; $\rho = 1000 \text{ kg/m}^3$

Phantom section: Flat Section; Space: 1.0 cm

Test Date: 1-25-2017; Ambient Temp: 24.0°C; Tissue Temp: 21.5°C

Probe: EX3DV4 - SN7409; ConvF(7.47, 7.47, 7.47); Calibrated: 5/17/2016;

Sensor-Surface: 1.4mm (Mechanical Surface Detection)

Electronics: DAE4 Sn859; Calibrated: 5/11/2016

Phantom: SAM Left; Type: QD000P40CC; Serial: TP: 1375

Measurement SW: DASY52, Version 52.8 (8); SEMCAD X Version 14.6.10 (7331)

Mode: GPRS 1900, Body SAR, Bottom Edge, Mid.ch, 3 Tx Slots

Area Scan (10x7x1): Measurement grid: dx=5mm, dy=15mm

Zoom Scan (5x6x7)/Cube 0: Measurement grid: dx=8mm, dy=8mm, dz=5mm

Reference Value = 16.96 V/m; Power Drift = 0.04 dB

Peak SAR (extrapolated) = 0.698 W/kg

SAR(1 g) = 0.406 W/kg

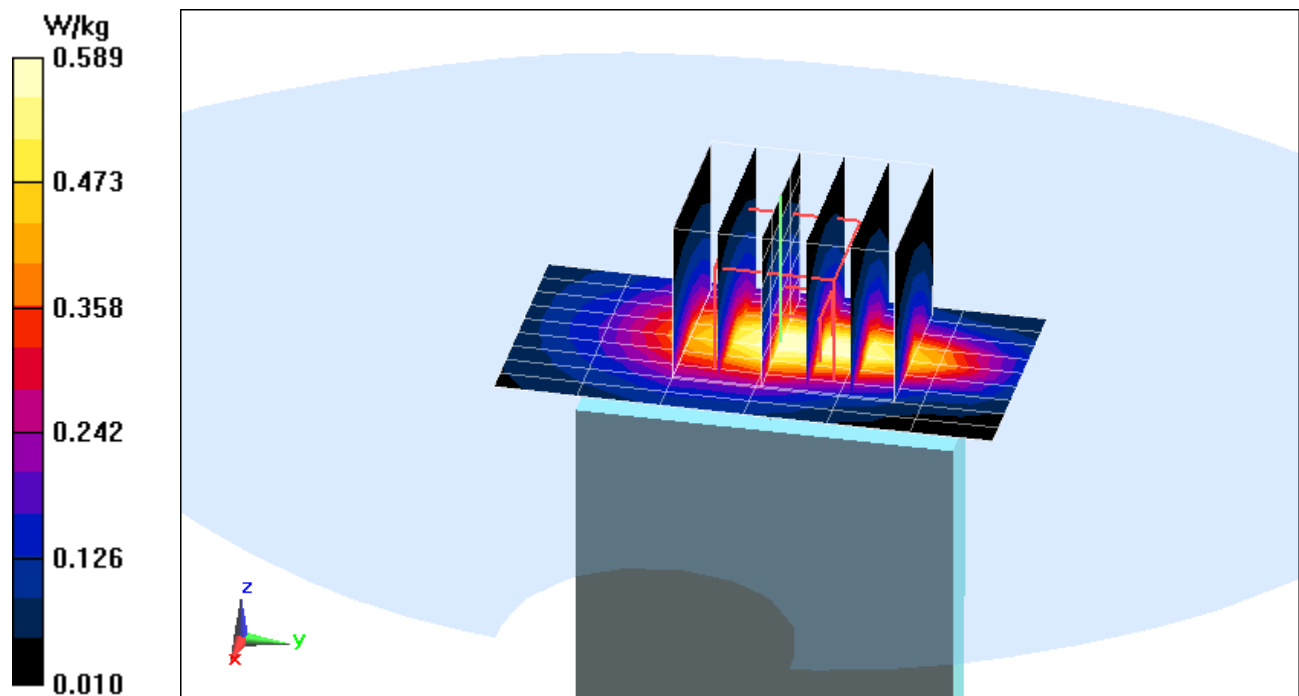

PCTEST ENGINEERING LABORATORY, INC.

DUT: ZNFH871; Type: Portable Handset; Serial: 08465

Communication System: UID 0, UMTS; Frequency: 1880 MHz; Duty Cycle: 1:1

Medium: 1900 Body Medium parameters used:

$f = 1880 \text{ MHz}$; $\sigma = 1.536 \text{ S/m}$; $\epsilon_r = 52.21$; $\rho = 1000 \text{ kg/m}^3$

Phantom section: Flat Section; Space: 1.0 cm

Test Date: 1-25-2017; Ambient Temp: 24.0°C; Tissue Temp: 21.5°C

Probe: EX3DV4 - SN7409; ConvF(7.47, 7.47, 7.47); Calibrated: 5/17/2016;

Sensor-Surface: 1.4mm (Mechanical Surface Detection)

Electronics: DAE4 Sn859; Calibrated: 5/11/2016

Phantom: SAM Left; Type: QD000P40CC; Serial: TP: 1375

Measurement SW: DASY52, Version 52.8 (8); SEMCAD X Version 14.6.10 (7331)

Mode: UMTS 1900, Body SAR, Back side, Mid.ch

Area Scan (9x14x1): Measurement grid: dx=15mm, dy=15mm

Zoom Scan (8x7x7)/Cube 1: Measurement grid: dx=8mm, dy=8mm, dz=5mm

Reference Value = 23.17 V/m; Power Drift = -0.10 dB

Peak SAR (extrapolated) = 1.33 W/kg

SAR(1 g) = 0.789 W/kg

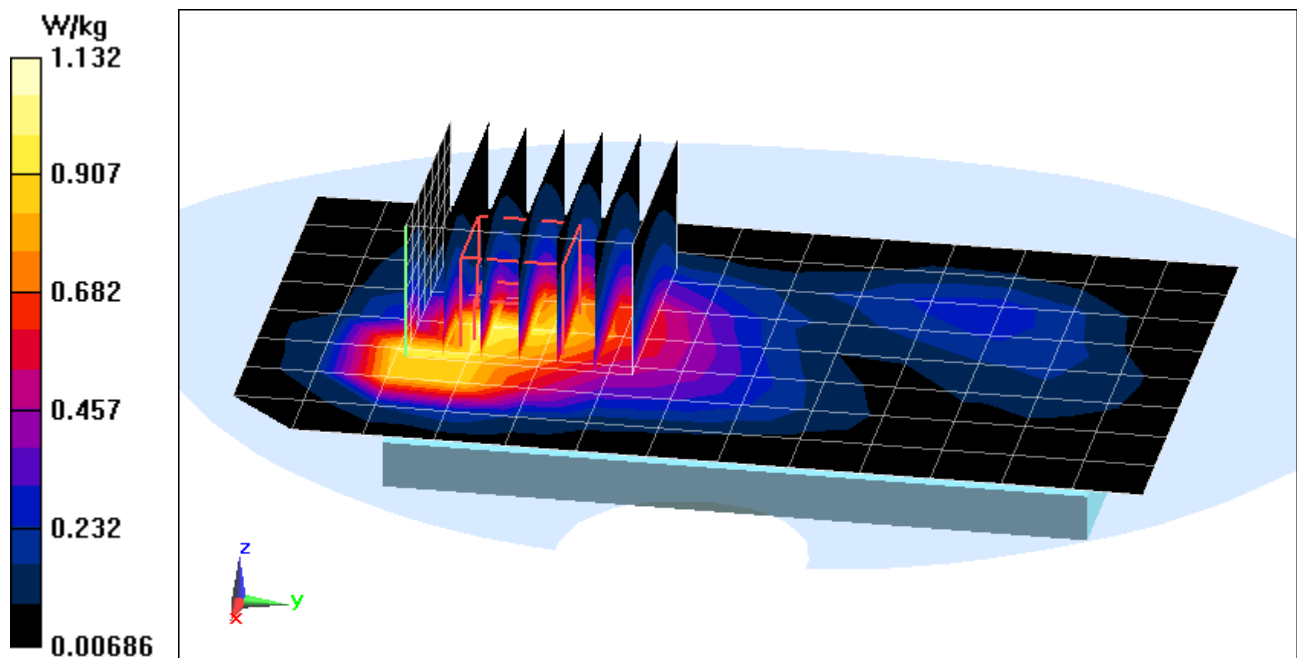

PCTEST ENGINEERING LABORATORY, INC.

DUT: ZNFH871; Type: Portable Handset; Serial: 08440

Communication System: UID 0, LTE Band 12; Frequency: 707.5 MHz; Duty Cycle: 1:1
Medium: 750 Body Medium parameters used (interpolated):
 $f = 707.5 \text{ MHz}$; $\sigma = 0.92 \text{ S/m}$; $\epsilon_r = 54.991$; $\rho = 1000 \text{ kg/m}^3$
Phantom section: Flat Section; Space: 1.0 cm

Test Date: 01-30-2017; Ambient Temp: 22.7°C; Tissue Temp: 20.8°C

Probe: ES3DV3 - SN3209; ConvF(6.19, 6.19, 6.19); Calibrated: 3/18/2016;
Sensor-Surface: 3mm (Mechanical Surface Detection)
Electronics: DAE4 Sn1364; Calibrated: 8/22/2016
Phantom: SAM Front; Type: QD000P40CD; Serial: TP:1758
Measurement SW: DASY52, Version 52.8 (8); SEMCAD X Version 14.6.10 (7331)

**Mode: LTE Band 12, Body SAR, Back side, Mid.ch, 10 MHz Bandwidth,
QPSK, 1 RB, 0 RB Offset**

Area Scan (9x13x1): Measurement grid: dx=15mm, dy=15mm

Zoom Scan (6x6x7)/Cube 0: Measurement grid: dx=8mm, dy=8mm, dz=5mm

Reference Value = 28.67 V/m; Power Drift = 0.01 dB

Peak SAR (extrapolated) = 1.03 W/kg

SAR(1 g) = 0.688 W/kg

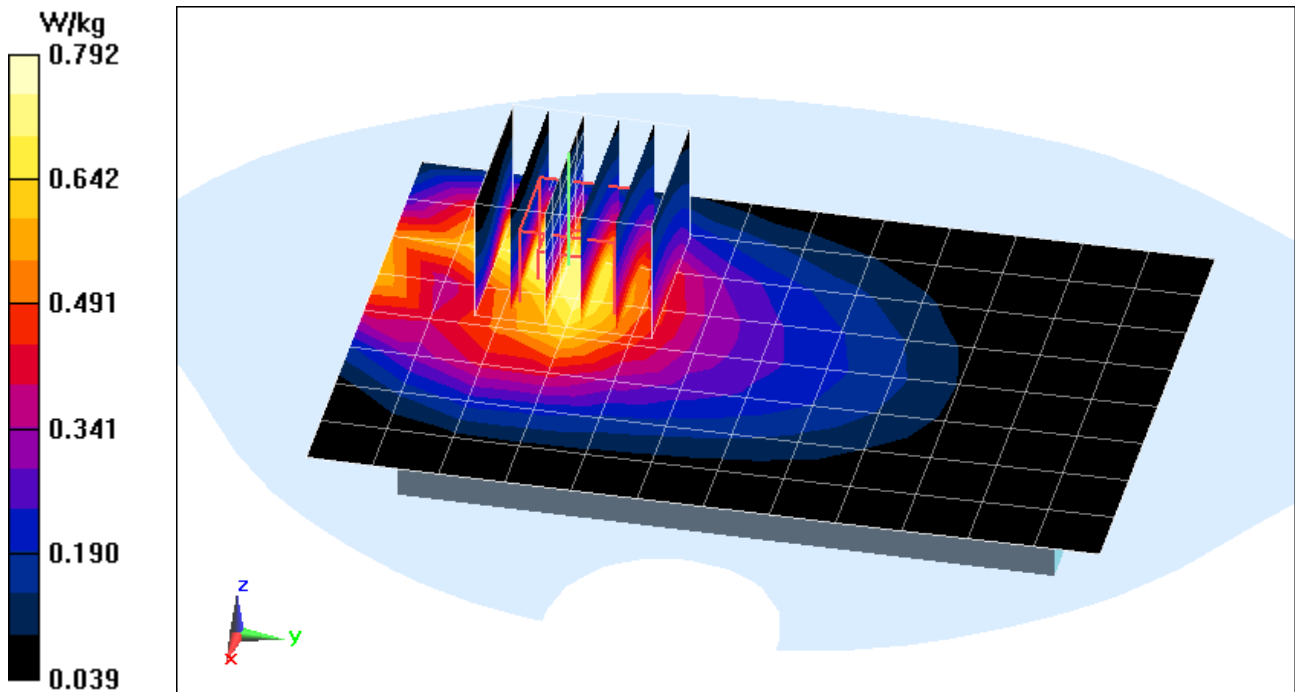

PCTEST ENGINEERING LABORATORY, INC.

DUT: ZNFH871; Type: Portable Handset; Serial: 08440

Communication System: UID 0, LTE Band 12; Frequency: 707.5 MHz; Duty Cycle: 1:1
Medium: 750 Body Medium parameters used (interpolated):
 $f = 707.5 \text{ MHz}$; $\sigma = 0.92 \text{ S/m}$; $\epsilon_r = 54.991$; $\rho = 1000 \text{ kg/m}^3$
Phantom section: Flat Section; Space: 1.0 cm

Test Date: 01-30-2017; Ambient Temp: 22.7°C; Tissue Temp: 20.8°C

Probe: ES3DV3 - SN3209; ConvF(6.19, 6.19, 6.19); Calibrated: 3/18/2016;
Sensor-Surface: 3mm (Mechanical Surface Detection)
Electronics: DAE4 Sn1364; Calibrated: 8/22/2016
Phantom: SAM Front; Type: QD000P40CD; Serial: TP:1758
Measurement SW: DASY52, Version 52.8 (8); SEMCAD X Version 14.6.10 (7331)

**Mode: LTE Band 12, Body SAR, Front side, Mid.ch, 10 MHz Bandwidth,
QPSK, 1 RB, 0 RB Offset**

Area Scan (9x13x1): Measurement grid: $dx=15\text{mm}$, $dy=15\text{mm}$

Zoom Scan (6x6x7)/Cube 0: Measurement grid: $dx=8\text{mm}$, $dy=8\text{mm}$, $dz=5\text{mm}$

Reference Value = 29.71 V/m; Power Drift = -0.01 dB

Peak SAR (extrapolated) = 1.23 W/kg

SAR(1 g) = 0.742 W/kg

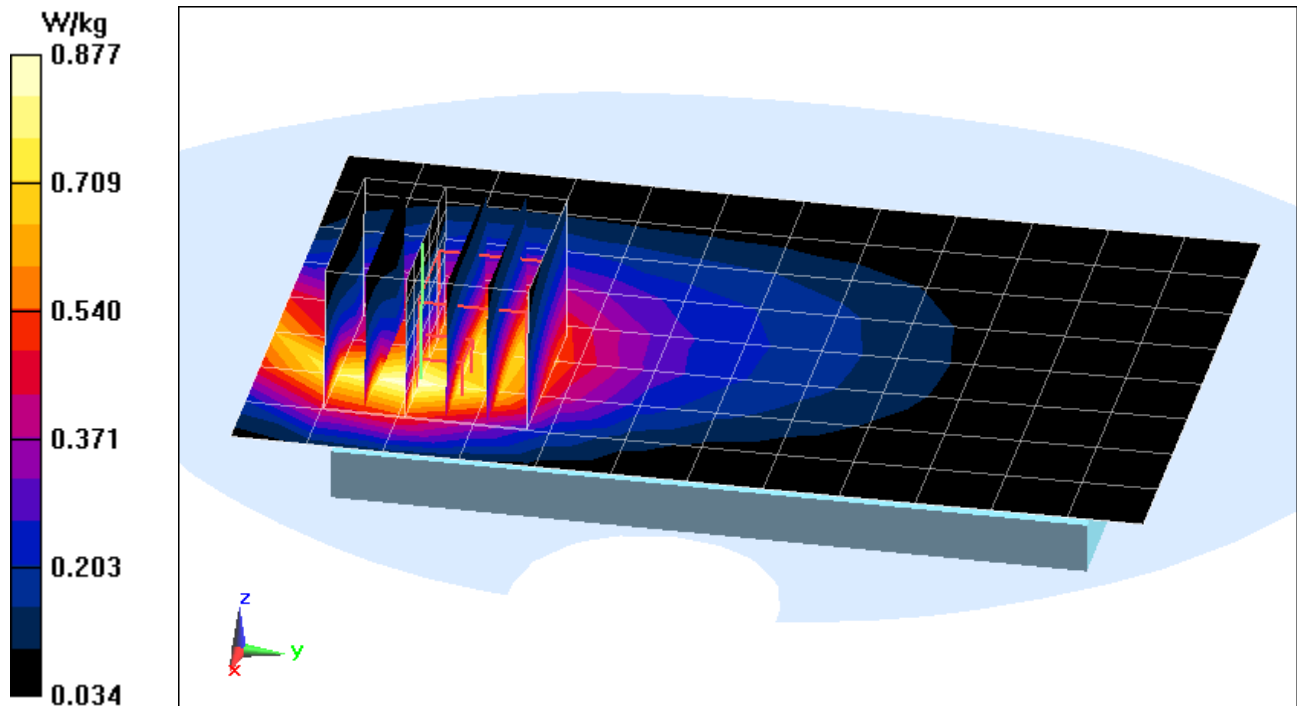

PCTEST ENGINEERING LABORATORY, INC.

DUT: ZNFH871; Type: Portable Handset; Serial: 08440

Communication System: UID 0, LTE Band 13; Frequency: 782 MHz; Duty Cycle: 1:1
Medium: 750 Body Medium parameters used (interpolated):
 $f = 782 \text{ MHz}$; $\sigma = 0.993 \text{ S/m}$; $\epsilon_r = 54.105$; $\rho = 1000 \text{ kg/m}^3$
Phantom section: Flat Section; Space: 1.0 cm

Test Date: 01-30-2017; Ambient Temp: 22.7°C; Tissue Temp: 20.8°C

Probe: ES3DV3 - SN3209; ConvF(6.19, 6.19, 6.19); Calibrated: 3/18/2016;
Sensor-Surface: 3mm (Mechanical Surface Detection)
Electronics: DAE4 Sn1364; Calibrated: 8/22/2016
Phantom: SAM Front; Type: QD000P40CD; Serial: TP:1758
Measurement SW: DASY52, Version 52.8 (8); SEMCAD X Version 14.6.10 (7331)

**Mode: LTE Band 13, Body SAR, Back side, Mid.ch, 10 MHz Bandwidth,
QPSK, 1 RB, 0 RB Offset**

Area Scan (9x13x1): Measurement grid: $dx=15\text{mm}$, $dy=15\text{mm}$

Zoom Scan (5x5x7)/Cube 0: Measurement grid: $dx=8\text{mm}$, $dy=8\text{mm}$, $dz=5\text{mm}$

Reference Value = 21.89 V/m; Power Drift = 0.07 dB

Peak SAR (extrapolated) = 0.656 W/kg

SAR(1 g) = 0.442 W/kg

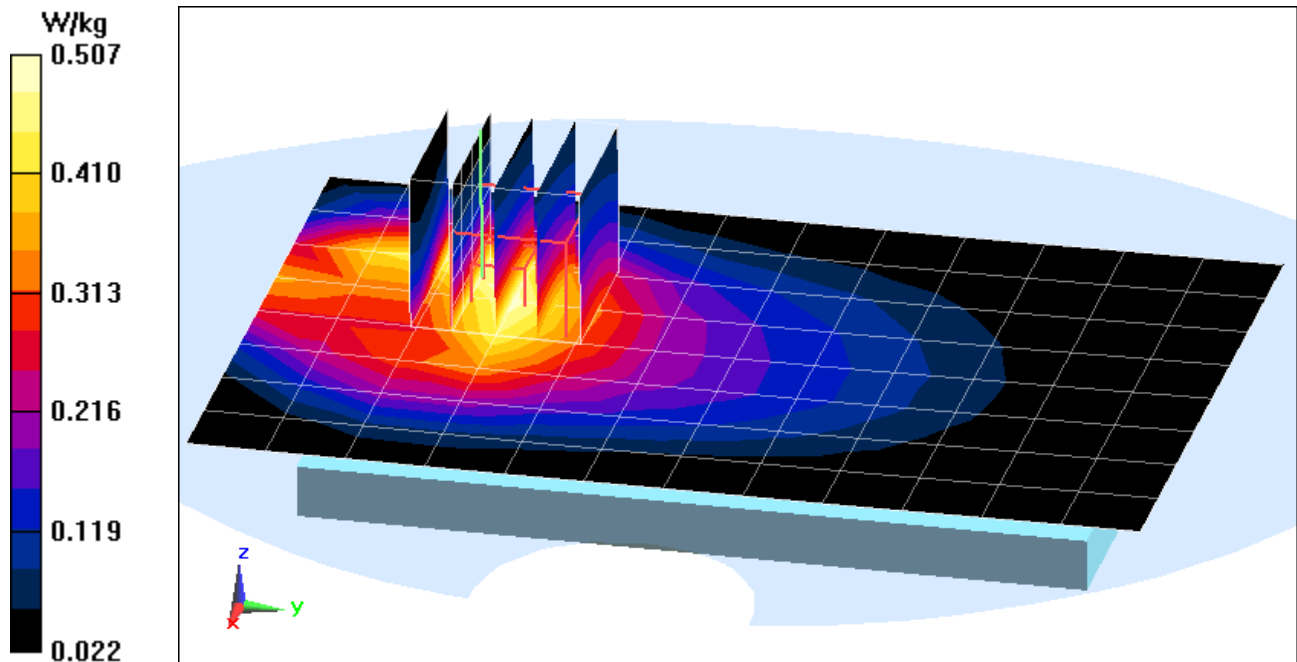

PCTEST ENGINEERING LABORATORY, INC.

DUT: ZNFH871; Type: Portable Handset; Serial: 08440

Communication System: UID 0, LTE Band 5; Frequency: 836.5 MHz; Duty Cycle: 1:1
Medium: 835 Body Medium parameters used (interpolated):
 $f = 836.5$ MHz; $\sigma = 1.001$ S/m; $\epsilon_r = 55.507$; $\rho = 1000$ kg/m³
Phantom section: Flat Section; Space: 1.0 cm

Test Date: 01-30-2017; Ambient Temp: 22.8°C; Tissue Temp: 21.1°C

Probe: ES3DV3 - SN3319; ConvF(6.04, 6.04, 6.04); Calibrated: 3/18/2016;
Sensor-Surface: 3mm (Mechanical Surface Detection)
Electronics: DAE4 Sn1368; Calibrated: 3/14/2016
Phantom: SAM with CRP (Left); Type: SAM; Serial: 1715
Measurement SW: DASY52, Version 52.8 (8); SEMCAD X Version 14.6.10 (7331)

**Mode: LTE Band 5 (Cell.), Body SAR, Back side, Mid.ch, 10 MHz Bandwidth,
QPSK, 1 RB, 0 RB Offset**

Area Scan (9x15x1): Measurement grid: dx=15mm, dy=15mm

Zoom Scan (6x6x7)/Cube 0: Measurement grid: dx=8mm, dy=8mm, dz=5mm

Reference Value = 23.32 V/m; Power Drift = -0.10 dB

Peak SAR (extrapolated) = 0.715 W/kg

SAR(1 g) = 0.495 W/kg

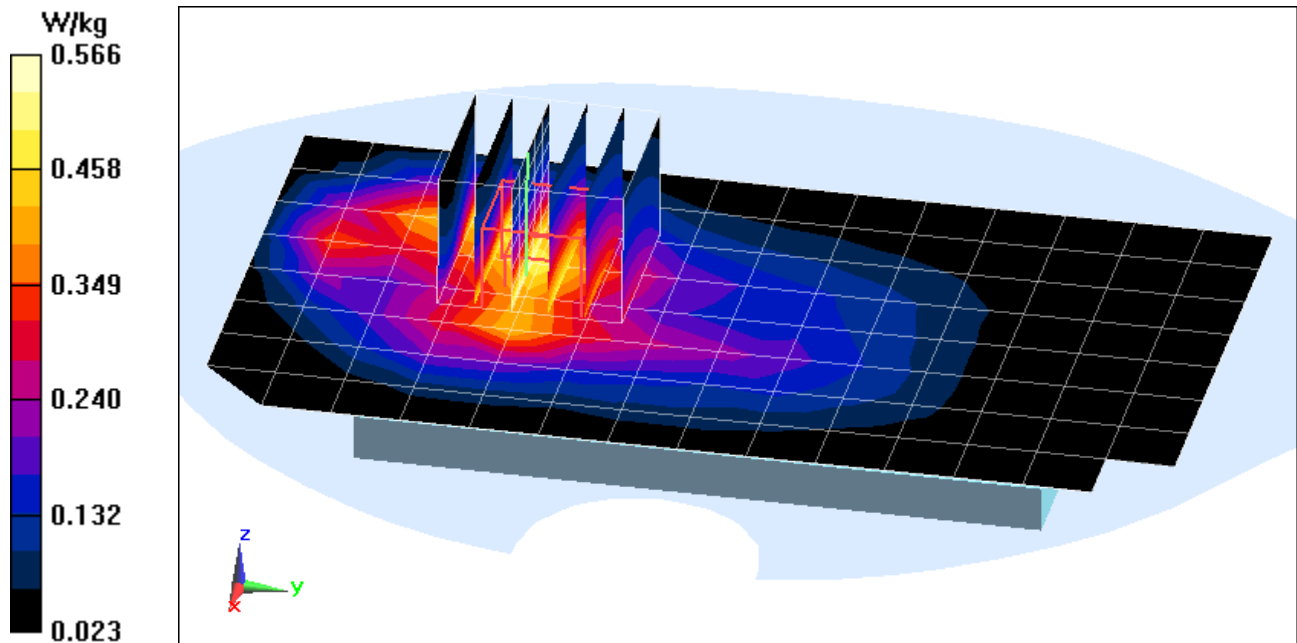

PCTEST ENGINEERING LABORATORY, INC.

DUT: ZNFH871; Type: Portable Handset; Serial: 08440

Communication System: UID 0, LTE Band 5 (Cell.); Frequency: 836.5 MHz; Duty Cycle: 1:1
Medium: 835 Body Medium parameters used (interpolated):
 $f = 836.5 \text{ MHz}$; $\sigma = 1.001 \text{ S/m}$; $\epsilon_r = 55.507$; $\rho = 1000 \text{ kg/m}^3$
Phantom section: Flat Section; Space: 1.0 cm

Test Date: 01-30-2017; Ambient Temp: 22.8°C; Tissue Temp: 21.1°C

Probe: ES3DV3 - SN3319; ConvF(6.04, 6.04, 6.04); Calibrated: 3/18/2016;
Sensor-Surface: 3mm (Mechanical Surface Detection)
Electronics: DAE4 Sn1368; Calibrated: 3/14/2016
Phantom: SAM with CRP (Left); Type: SAM; Serial: 1715
Measurement SW: DASY52, Version 52.8 (8); SEMCAD X Version 14.6.10 (7331)

**Mode: LTE Band 5 (Cell.), Body SAR, Front side, Mid.ch, 10 MHz Bandwidth,
QPSK, 1 RB, 0 RB Offset**

Area Scan (9x15x1): Measurement grid: dx=15mm, dy=15mm

Zoom Scan (8x7x7)/Cube 0: Measurement grid: dx=8mm, dy=8mm, dz=5mm

Reference Value = 21.74 V/m; Power Drift = 0.00 dB

Peak SAR (extrapolated) = 0.737 W/kg

SAR(1 g) = 0.497 W/kg

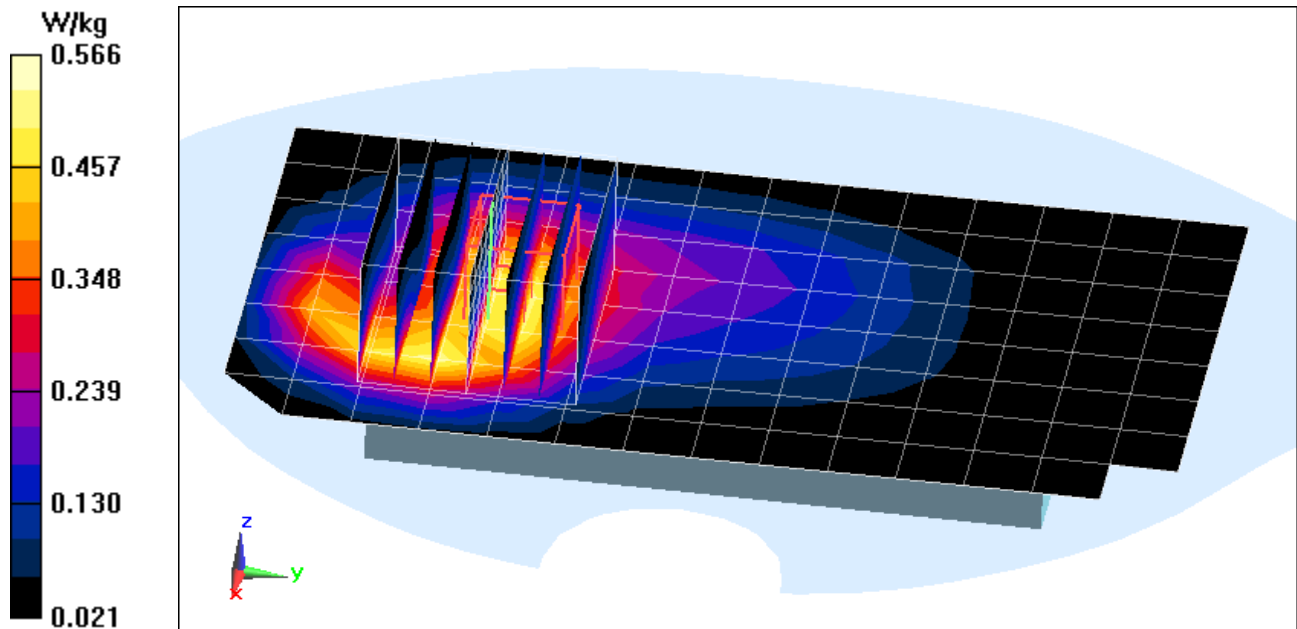

PCTEST ENGINEERING LABORATORY, INC.

DUT: ZNFH871; Type: Portable Handset; Serial: 08440

Communication System: UID 0, LTE Band 66 (AWS); Frequency: 1745 MHz; Duty Cycle: 1:1
Medium: 1750 Body Medium parameters used (interpolated):
 $f = 1745 \text{ MHz}$; $\sigma = 1.501 \text{ S/m}$; $\epsilon_r = 51.593$; $\rho = 1000 \text{ kg/m}^3$
Phantom section: Flat Section; Space: 1.0 cm

Test Date: 01-23-2017; Ambient Temp: 23.6°C; Tissue Temp: 23.0°C

Probe: ES3DV3 - SN3209; ConvF(4.99, 4.99, 4.99); Calibrated: 3/18/2016;
Sensor-Surface: 3mm (Mechanical Surface Detection)
Electronics: DAE4 Sn1364; Calibrated: 8/22/2016
Phantom: SAM Front; Type: QD000P40CD; Serial: TP:1758
Measurement SW: DASY52, Version 52.8 (8); SEMCAD X Version 14.6.10 (7331)

**Mode: LTE Band 66 (AWS), Body SAR, Back side, Mid.ch, 20 MHz Bandwidth,
QPSK, 1 RB, 50 RB Offset**

Area Scan (9x15x1): Measurement grid: dx=15mm, dy=15mm
Zoom Scan (5x5x7)/Cube 0: Measurement grid: dx=8mm, dy=8mm, dz=5mm
Reference Value = 28.69 V/m; Power Drift = -0.02 dB
Peak SAR (extrapolated) = 1.62 W/kg
SAR(1 g) = 1.100 W/kg

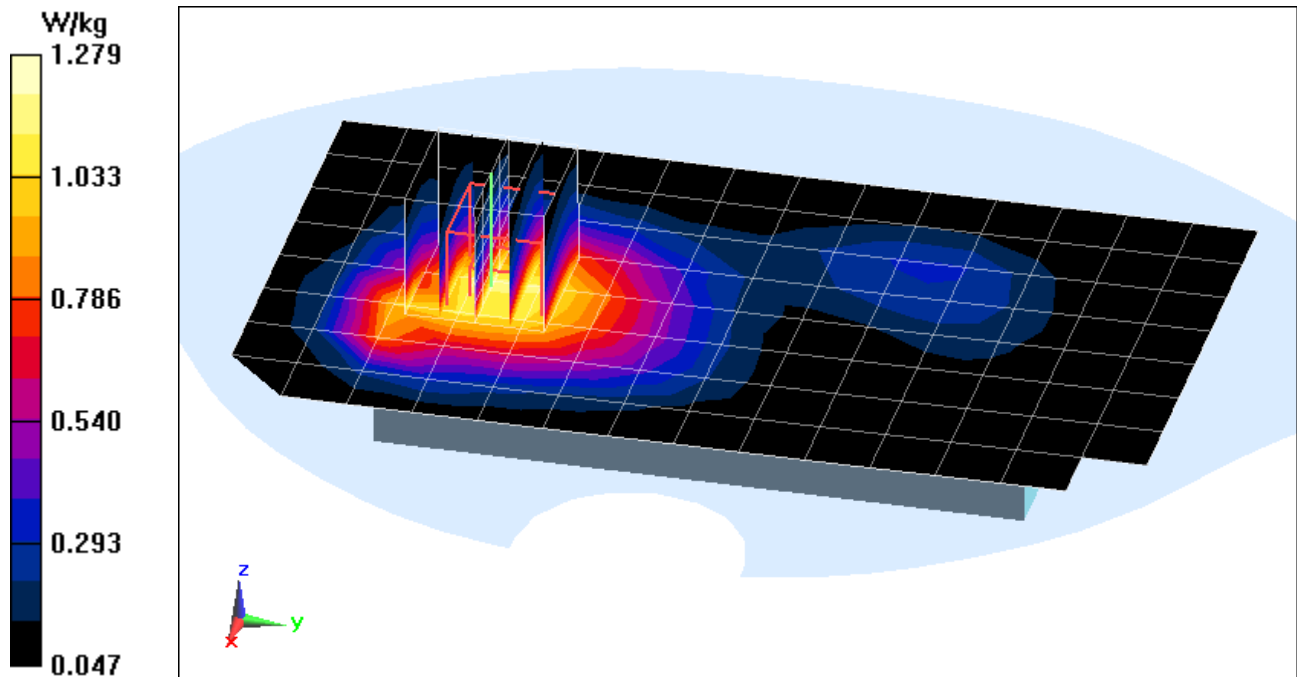

PCTEST ENGINEERING LABORATORY, INC.

DUT: ZNFH871; Type: Portable Handset; Serial: 08457

Communication System: UID 0, LTE Band 25 (PCS); Frequency: 1860 MHz; Duty Cycle: 1:1
Medium: 1900 Body Medium parameters used (interpolated):
 $f = 1860 \text{ MHz}$; $\sigma = 1.491 \text{ S/m}$; $\epsilon_r = 52.055$; $\rho = 1000 \text{ kg/m}^3$
Phantom section: Flat Section; Space: 1.0 cm

Test Date: 01-23-2017; Ambient Temp: 23.9°C; Tissue Temp: 23.4°C

Probe: EX3DV4 - SN7409; ConvF(7.47, 7.47, 7.47); Calibrated: 5/17/2016;
Sensor-Surface: 1.4mm (Mechanical Surface Detection)
Electronics: DAE4 Sn859; Calibrated: 5/11/2016
Phantom: SAM Left; Type: QD000P40CC; Serial: TP: 1375
Measurement SW: DASY52, Version 52.8 (8); SEMCAD X Version 14.6.10 (7331)

**Mode: LTE Band 25 (PCS), Body SAR, Back side, Low.ch, 20 MHz Bandwidth,
QPSK, 1 RB, 50 RB Offset**

Area Scan (9x15x1): Measurement grid: $dx=15\text{mm}$, $dy=15\text{mm}$

Zoom Scan (9x7x7)/Cube 0: Measurement grid: $dx=8\text{mm}$, $dy=8\text{mm}$, $dz=5\text{mm}$

Reference Value = 25.86 V/m; Power Drift = 0.02 dB

Peak SAR (extrapolated) = 1.68 W/kg

SAR(1 g) = 0.974 W/kg

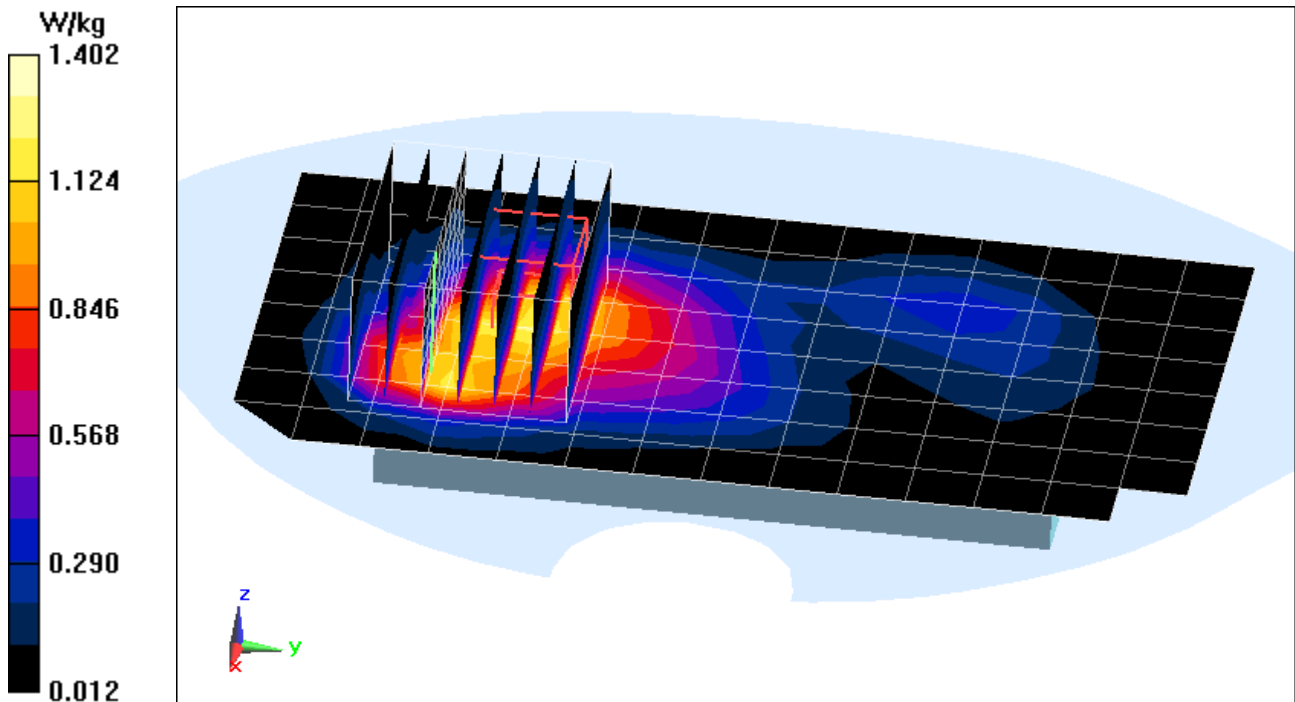

PCTEST ENGINEERING LABORATORY, INC.

DUT: ZNFH871; Type: Portable Handset; Serial: 08457

Communication System: UID 0, LTE Band 25 (PCS); Frequency: 1882.5 MHz; Duty Cycle: 1:1
Medium: 1900 Body Medium parameters used (interpolated):
 $f = 1882.5 \text{ MHz}$; $\sigma = 1.515 \text{ S/m}$; $\epsilon_r = 51.976$; $\rho = 1000 \text{ kg/m}^3$
Phantom section: Flat Section; Space: 1.0 cm

Test Date: 01-23-2017; Ambient Temp: 23.9°C; Tissue Temp: 23.4°C

Probe: EX3DV4 - SN7409; ConvF(7.47, 7.47, 7.47); Calibrated: 5/17/2016;
Sensor-Surface: 1.4mm (Mechanical Surface Detection)
Electronics: DAE4 Sn859; Calibrated: 5/11/2016
Phantom: SAM Left; Type: QD000P40CC; Serial: TP: 1375
Measurement SW: DASY52, Version 52.8 (8); SEMCAD X Version 14.6.10 (7331)

**Mode: LTE Band 25 (PCS), Body SAR, Bottom Edge, Mid.ch, 20 MHz Bandwidth,
QPSK, 1 RB, 0 RB Offset**

Area Scan (9x9x1): Measurement grid: dx=5mm, dy=15mm

Zoom Scan (5x5x7)/Cube 0: Measurement grid: dx=8mm, dy=8mm, dz=5mm

Reference Value = 29.04 V/m; Power Drift = -0.03 dB

Peak SAR (extrapolated) = 2.09 W/kg

SAR(1 g) = 1.19 W/kg

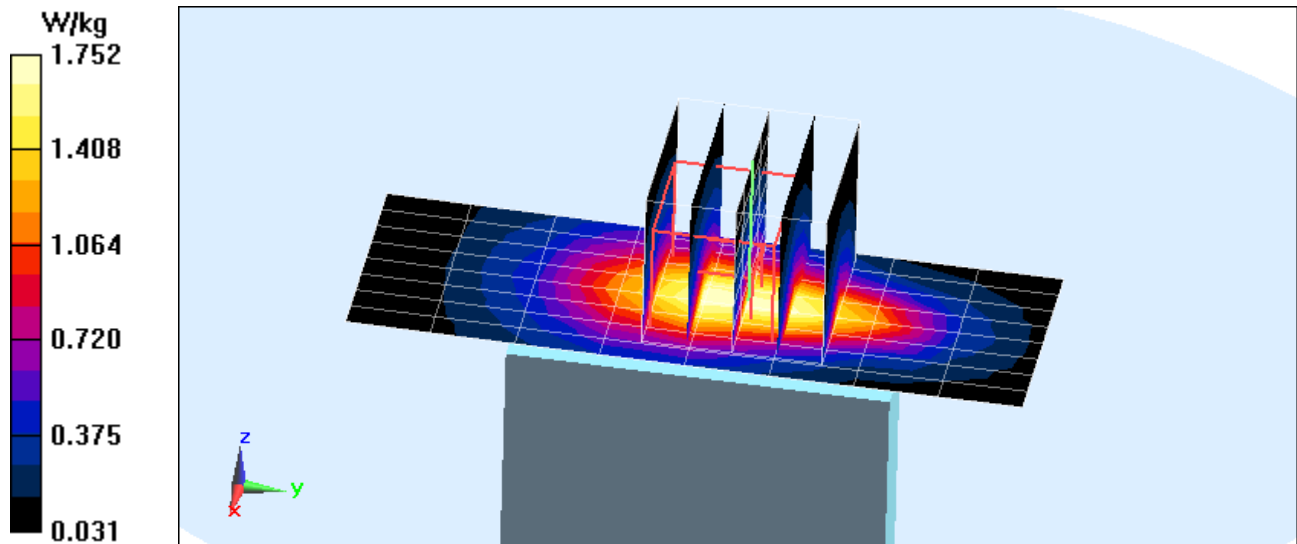

PCTEST ENGINEERING LABORATORY, INC.

DUT: ZNFH871; Type: Portable Handset; Serial: 08457

Communication System: UID 0, LTE Band 30; Frequency: 2310 MHz; Duty Cycle: 1:1
Medium: 2300 Body Medium parameters used:
 $f = 2310 \text{ MHz}$; $\sigma = 1.846 \text{ S/m}$; $\epsilon_r = 52.806$; $\rho = 1000 \text{ kg/m}^3$
Phantom section: Flat Section; Space: 1.0 cm

Test Date: 01-30-2017; Ambient Temp: 22.5°C; Tissue Temp: 21.5°C

Probe: EX3DV4 - SN7406; ConvF(7.37, 7.37, 7.37); Calibrated: 4/19/2016;

Sensor-Surface: 1.4mm (Mechanical Surface Detection)

Electronics: DAE4 Sn1407; Calibrated: 4/14/2016

Phantom: SAM 5.0 front; Type: QD000P40CD; Serial: TP:-1648

Measurement SW: DASY52, Version 52.8 (8); SEMCAD X Version 14.6.10 (7331)

**Mode: LTE Band 30, Body SAR, Back side, Mid.ch, 10 MHz Bandwidth,
QPSK, 1 RB, 0 RB Offset**

Area Scan (11x18x1): Measurement grid: dx=12mm, dy=12mm

Zoom Scan (7x7x7)/Cube 0: Measurement grid: dx=5mm, dy=5mm, dz=5mm

Reference Value = 26.62 V/m; Power Drift = 0.10 dB

Peak SAR (extrapolated) = 2.21 W/kg

SAR(1 g) = 1.16 W/kg

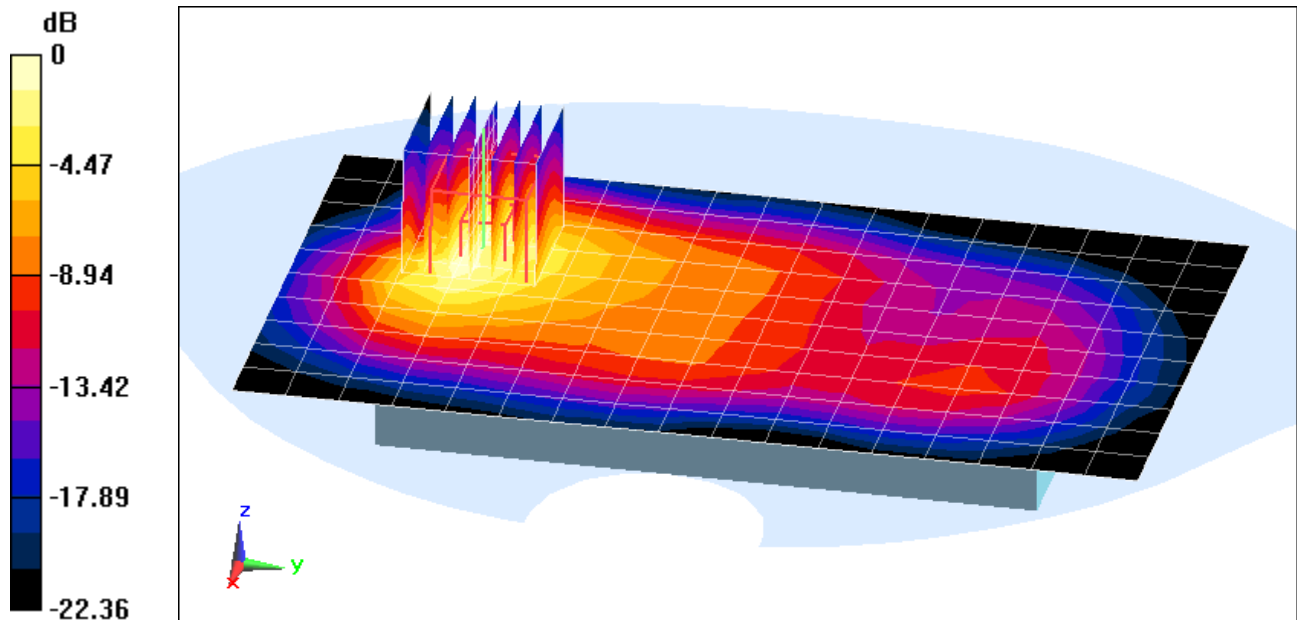

0 dB = 1.79 W/kg = 2.53 dBW/kg

PCTEST ENGINEERING LABORATORY, INC.

DUT: ZNFH871; Type: Portable Handset; Serial: 08515

Communication System: UID 0, LTE Band 7; Frequency: 2560 MHz; Duty Cycle: 1:1
Medium: 2600 Body Medium parameters used (interpolated):
 $f = 2560 \text{ MHz}$; $\sigma = 2.189 \text{ S/m}$; $\epsilon_r = 51.863$; $\rho = 1000 \text{ kg/m}^3$
Phantom section: Flat Section; Space: 1.0 cm

Test Date: 01-30-2017; Ambient Temp: 22.5°C; Tissue Temp: 21.5°C

Probe: EX3DV4 - SN7406; ConvF(6.94, 6.94, 6.94); Calibrated: 4/19/2016;

Sensor-Surface: 1.4mm (Mechanical Surface Detection)

Electronics: DAE4 Sn1407; Calibrated: 4/14/2016

Phantom: SAM 5.0 front; Type: QD000P40CD; Serial: TP:-1648

Measurement SW: DASY52, Version 52.8 (8); SEMCAD X Version 14.6.10 (7331)

**Mode: LTE Band 7, Body SAR, Back side, High.ch, 20 MHz Bandwidth,
QPSK, 1 RB, 0 RB Offset**

Area Scan (11x18x1): Measurement grid: dx=12mm, dy=12mm

Zoom Scan (7x7x7)/Cube 0: Measurement grid: dx=5mm, dy=5mm, dz=5mm

Reference Value = 12.76 V/m; Power Drift = -0.10 dB

Peak SAR (extrapolated) = 0.837 W/kg

SAR(1 g) = 0.317 W/kg

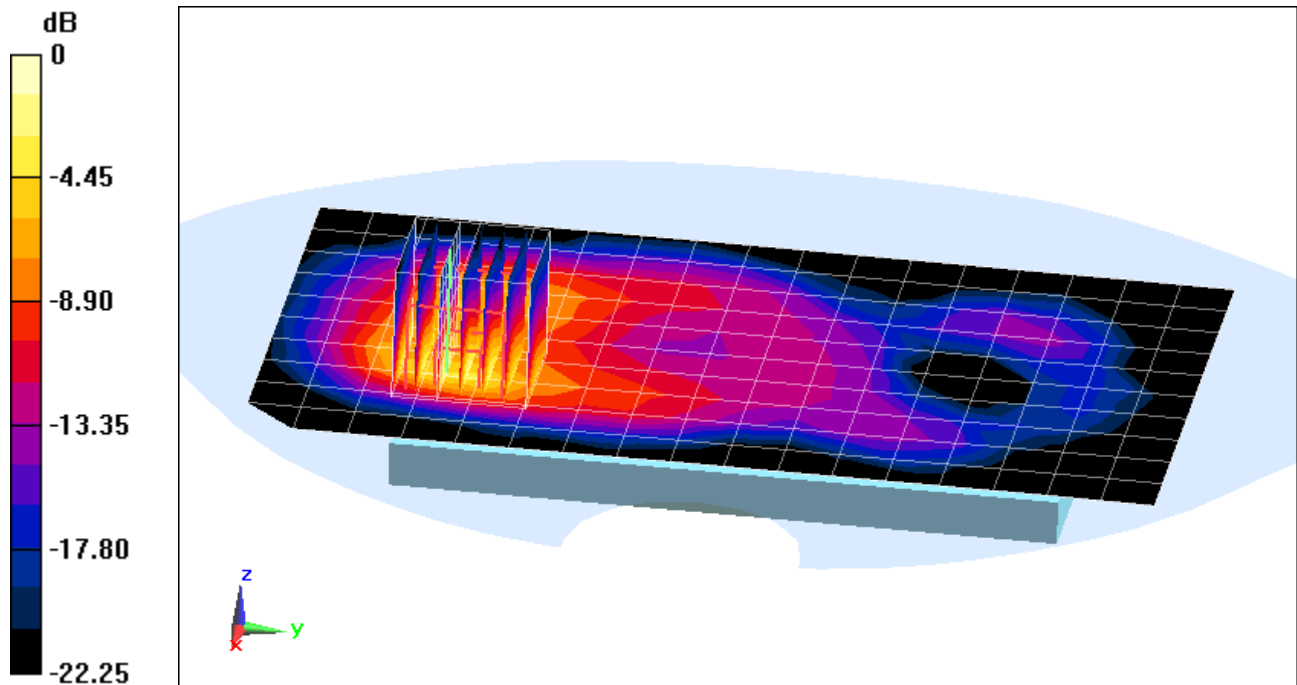

0 dB = 0.607 W/kg = -2.17 dBW/kg

PCTEST ENGINEERING LABORATORY, INC.

DUT: ZNFH871; Type: Portable Handset; Serial: 08515

Communication System: UID 0, LTE Band 7; Frequency: 2560 MHz; Duty Cycle: 1:1
Medium: 2600 Body Medium parameters used (interpolated):
 $f = 2560$ MHz; $\sigma = 2.189$ S/m; $\epsilon_r = 51.863$; $\rho = 1000$ kg/m³
Phantom section: Flat Section; Space: 1.0 cm

Test Date: 01-30-2017; Ambient Temp: 22.5°C; Tissue Temp: 21.5°C

Probe: EX3DV4 - SN7406; ConvF(6.94, 6.94, 6.94); Calibrated: 4/19/2016;

Sensor-Surface: 1.4mm (Mechanical Surface Detection)

Electronics: DAE4 Sn1407; Calibrated: 4/14/2016

Phantom: SAM 5.0 front; Type: QD000P40CD; Serial: TP:-1648

Measurement SW: DASY52, Version 52.8 (8); SEMCAD X Version 14.6.10 (7331)

**Mode: LTE Band 7, Body SAR, Bottom Edge, High.ch, 20 MHz Bandwidth,
QPSK, 1 RB, 0 RB Offset**

Area Scan (11x11x1): Measurement grid: dx=5mm, dy=12mm

Zoom Scan (7x7x7)/Cube 0: Measurement grid: dx=5mm, dy=5mm, dz=5mm

Reference Value = 15.00 V/m; Power Drift = 0.00 dB

Peak SAR (extrapolated) = 0.900 W/kg

SAR(1 g) = 0.447 W/kg

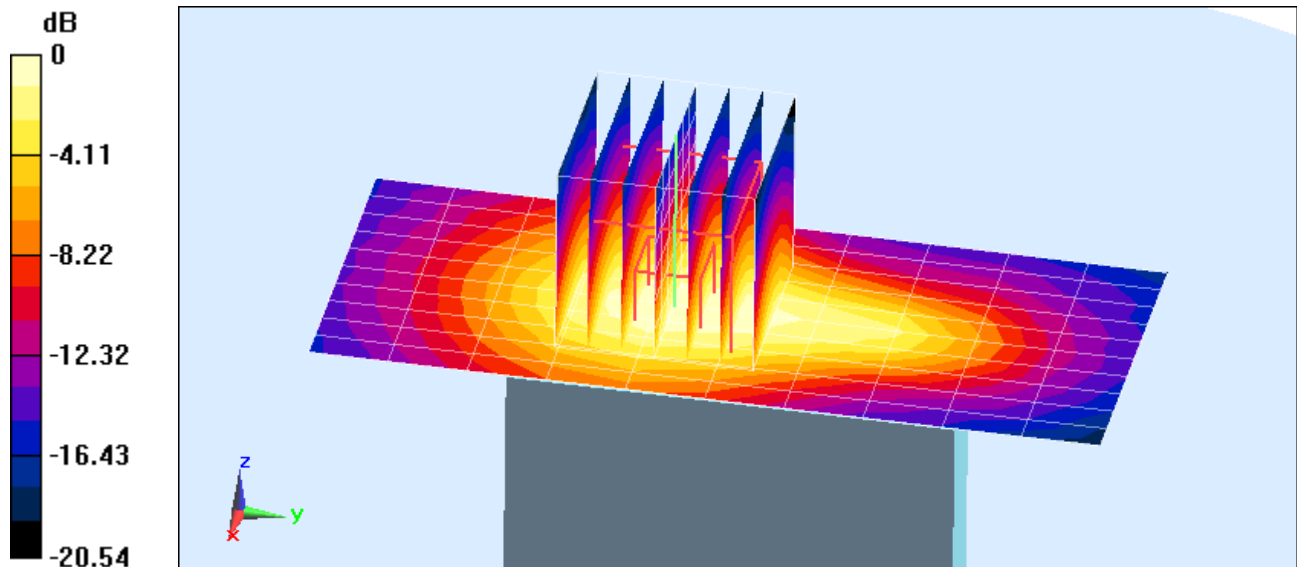

0 dB = 0.720 W/kg = -1.43 dBW/kg

PCTEST ENGINEERING LABORATORY, INC.

DUT: ZNFH871; Type: Portable Handset; Serial: 08564

Communication System: UID 0, IEEE 802.11b; Frequency: 2437 MHz; Duty Cycle: 1:1
Medium: 2450 Body Medium parameters used (interpolated):
 $f = 2437 \text{ MHz}$; $\sigma = 1.956 \text{ S/m}$; $\epsilon_r = 51.405$; $\rho = 1000 \text{ kg/m}^3$
Phantom section: Flat Section; Space: 1.0 cm

Test Date: 01-24-2017; Ambient Temp: 24.0°C; Tissue Temp: 23.0°C

Probe: EX3DV4 - SN7406; ConvF(7.24, 7.24, 7.24); Calibrated: 4/19/2016;
Sensor-Surface: 1.4mm (Mechanical Surface Detection)
Electronics: DAE4 Sn1407; Calibrated: 4/14/2016
Phantom: SAM 5.0 front; Type: QD000P40CD; Serial: TP:-1648
Measurement SW: DASY52, Version 52.8 (8); SEMCAD X Version 14.6.10 (7331)

**Mode: IEEE 802.11b, 22 MHz Bandwidth, Body SAR,
Ch 6, 1 Mbps, Back Side, Secondary Ant**

Area Scan (11x17x1): Measurement grid: $dx=12\text{mm}$, $dy=12\text{mm}$
Zoom Scan (7x7x7)/Cube 0: Measurement grid: $dx=5\text{mm}$, $dy=5\text{mm}$, $dz=5\text{mm}$
Reference Value = 13.70 V/m; Power Drift = -0.01 dB
Peak SAR (extrapolated) = 0.618 W/kg
SAR(1 g) = 0.332 W/kg

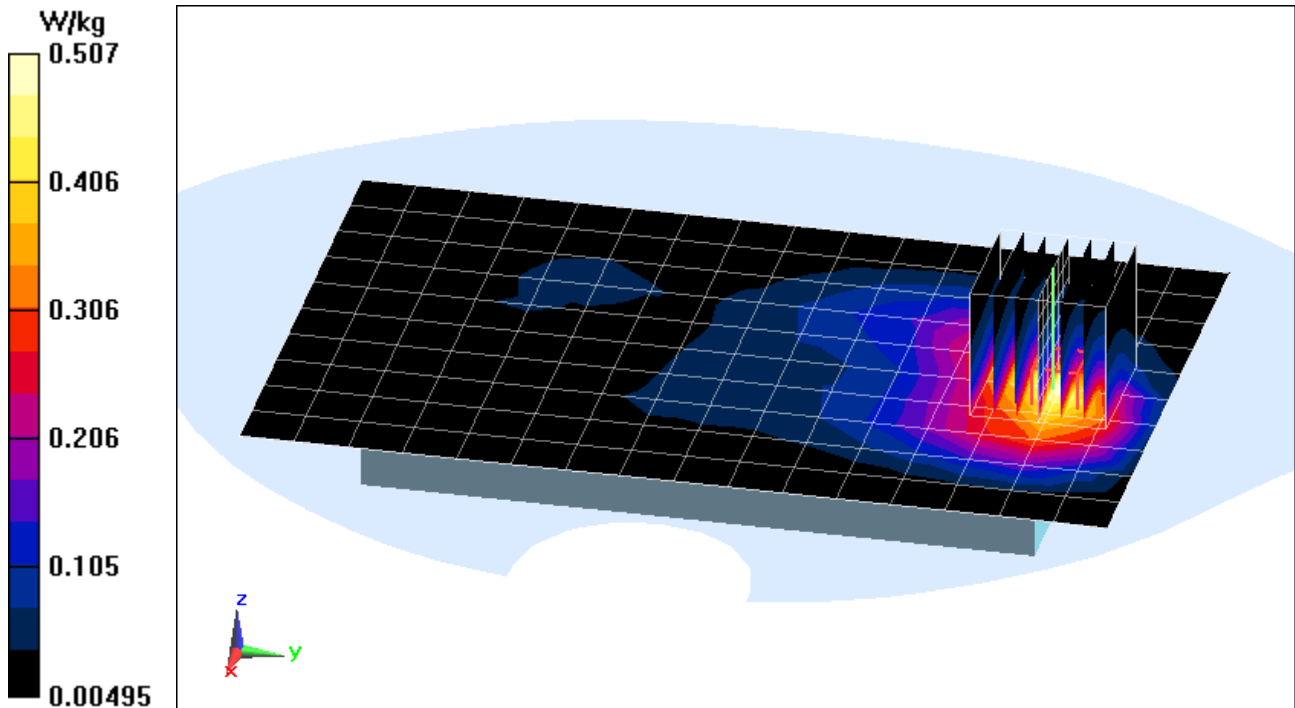

PCTEST ENGINEERING LABORATORY, INC.

DUT: ZNFH871; Type: Portable Handset; Serial: 08564

Communication System: UID 0, 802.11a 5.2-5.8 GHz Band; Frequency: 5745 MHz; Duty Cycle: 1:1

Medium: 5 GHz Body Medium parameters used:

$f = 5745 \text{ MHz}$; $\sigma = 6.172 \text{ S/m}$; $\epsilon_r = 47.057$; $\rho = 1000 \text{ kg/m}^3$

Phantom section: Flat Section; Space: 1.0 cm

Test Date: 01-22-2017; Ambient Temp: 21.9°C; Tissue Temp: 21.4°C

Probe: EX3DV4 - SN3914; ConvF(3.86, 3.86, 3.86); Calibrated: 2/22/2016;

Sensor-Surface: 1.4mm (Mechanical Surface Detection)

Electronics: DAE4 Sn1272; Calibrated: 2/18/2016

Phantom: SAM with CRP v5.0 Front; Type: QD000P40CD; Serial: 1646

Measurement SW: DASY52, Version 52.8 (8); SEMCAD X Version 14.6.10 (7331)

**Mode: IEEE 802.11a, UNII-3, 20 MHz Bandwidth, Body SAR,
Ch 149, 6 Mbps, Back Side, Primary Ant**

Area Scan (13x19x1): Measurement grid: dx=10mm, dy=10mm

Zoom Scan (7x7x7)/Cube 0: Measurement grid: dx=4mm, dy=4mm, dz=1.4mm; Graded Ratio: 1.4

Reference Value = 9.189 V/m; Power Drift = 0.10 dB

Peak SAR (extrapolated) = 1.75 W/kg

SAR(1 g) = 0.481 W/kg

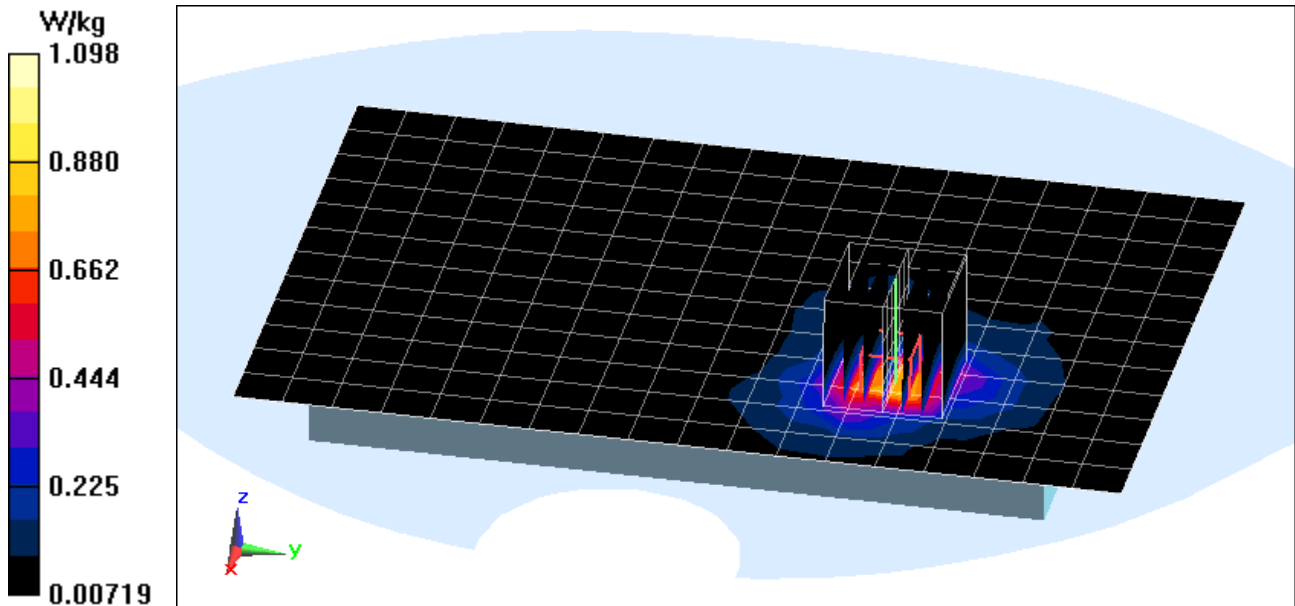

PCTEST ENGINEERING LABORATORY, INC.

DUT: ZNFH871; Type: Portable Handset; Serial: 08564

Communication System: UID 0, Bluetooth; Frequency: 2441 MHz; Duty Cycle: 1:1.295

Medium: 2450 Body Medium parameters used (interpolated):

$f = 2441 \text{ MHz}$; $\sigma = 1.961 \text{ S/m}$; $\epsilon_r = 51.39$; $\rho = 1000 \text{ kg/m}^3$

Phantom section: Flat Section; Space: 1.0 cm

Test Date: 01-24-2017; Ambient Temp: 24.0°C; Tissue Temp: 23.0°C

Probe: EX3DV4 - SN7406; ConvF(7.24, 7.24, 7.24); Calibrated: 4/19/2016;

Sensor-Surface: 1.4mm (Mechanical Surface Detection)

Electronics: DAE4 Sn1407; Calibrated: 4/14/2016

Phantom: SAM 5.0 front; Type: QD000P40CD; Serial: TP:-1648

Measurement SW: DASY52, Version 52.8 (8); SEMCAD X Version 14.6.10 (7331)

Mode: Bluetooth, Body SAR, Ch 39, 1 Mbps, Back Side

Area Scan (11x17x1): Measurement grid: dx=12mm, dy=12mm

Zoom Scan (7x7x7)/Cube 0: Measurement grid: dx=5mm, dy=5mm, dz=5mm

Reference Value = 5.432 V/m; Power Drift = 0.13 dB

Peak SAR (extrapolated) = 0.0980 W/kg

SAR(1 g) = 0.053 W/kg

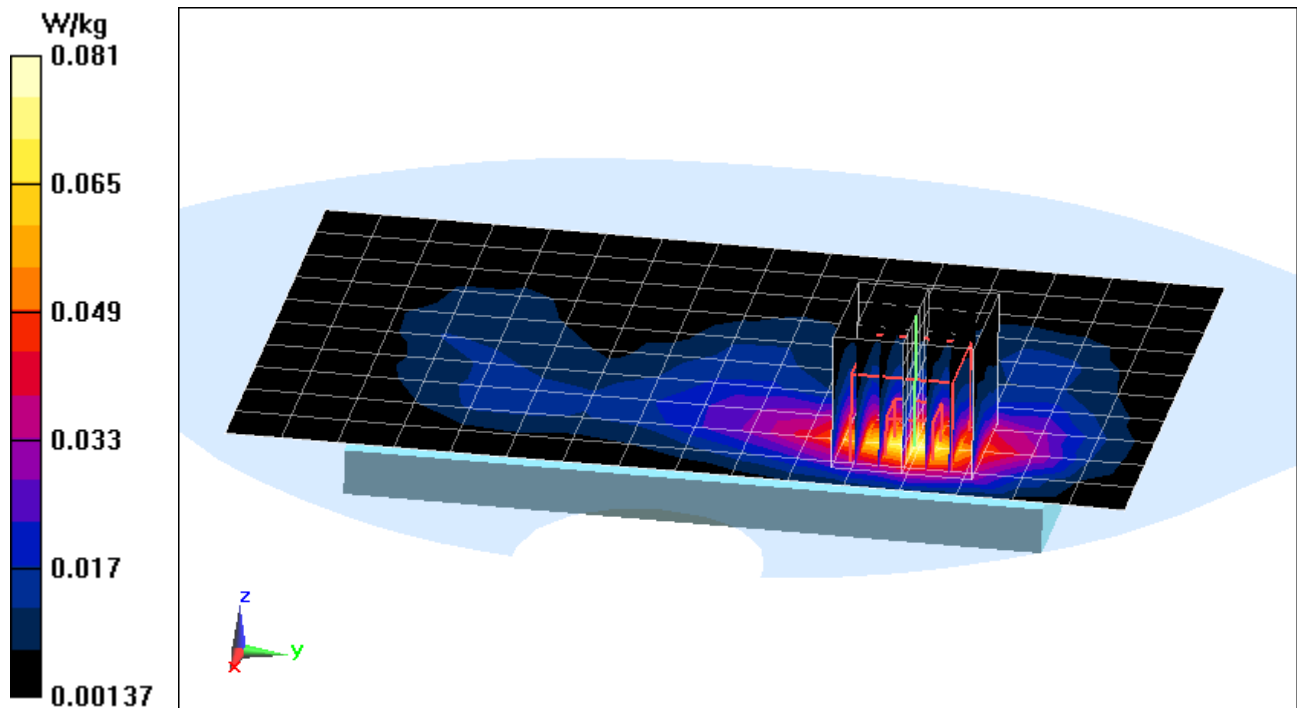

APPENDIX B: SYSTEM VERIFICATION

PCTEST ENGINEERING LABORATORY, INC.

DUT: Dipole 750 MHz; Type: D750V3; Serial: 1161

Communication System: UID 0, CW; Frequency: 750 MHz; Duty Cycle: 1:1

Medium: 750 Head Medium parameters used (interpolated):

$f = 750 \text{ MHz}$; $\sigma = 0.906 \text{ S/m}$; $\epsilon_r = 42.188$; $\rho = 1000 \text{ kg/m}^3$

Phantom section: Flat Section; Space: 1.5 cm

Test Date: 01-25-2017; Ambient Temp: 22.3°C; Tissue Temp: 22.2°C

Probe: ES3DV3 - SN3209; ConvF(6.6, 6.6, 6.6); Calibrated: 3/18/2016;

Sensor-Surface: 3mm (Mechanical Surface Detection)

Electronics: DAE4 Sn1364; Calibrated: 8/22/2016

Phantom: SAM Right; Type: SAM; Serial: 1757

Measurement SW: DASY52, Version 52.8 (8); SEMCAD X Version 14.6.10 (7331)

750 MHz System Verification at 23.0 dBm (200 mW)

Area Scan (7x15x1): Measurement grid: dx=15mm, dy=15mm

Zoom Scan (5x5x7)/Cube 0: Measurement grid: dx=8mm, dy=8mm, dz=5mm

Peak SAR (extrapolated) = 2.29 W/kg

SAR(1 g) = 1.57 W/kg

Deviation(1 g) = -3.92%

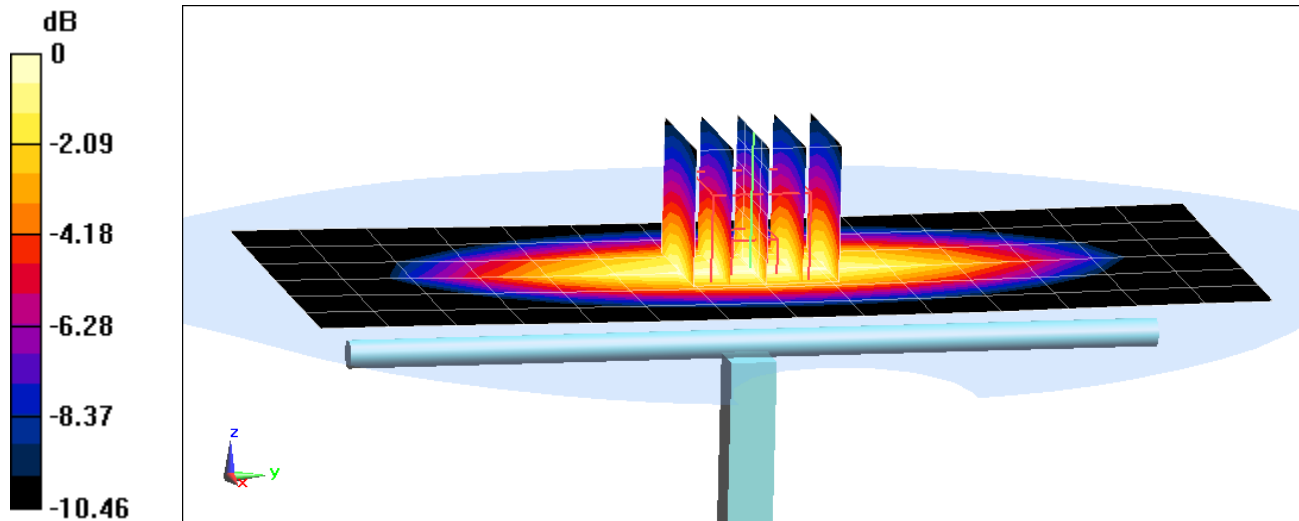

0 dB = 1.84 W/kg = 2.65 dBW/kg

PCTEST ENGINEERING LABORATORY, INC.

DUT: Dipole 835 MHz; Type: D835V2; Serial: 4d047

Communication System: UID 0, CW; Frequency: 835 MHz; Duty Cycle: 1:1

Medium: 835 Head Medium parameters used:

$f = 835 \text{ MHz}$; $\sigma = 0.888 \text{ S/m}$; $\epsilon_r = 40.454$; $\rho = 1000 \text{ kg/m}^3$

Phantom section: Flat Section; Space: 1.5 cm

Test Date: 01-30-2017; Ambient Temp: 23.0°C; Tissue Temp: 21.3°C

Probe: ES3DV3 - SN3287; ConvF(6.67, 6.67, 6.67); Calibrated: 9/19/2016;

Sensor-Surface: 3mm (Mechanical Surface Detection)

Electronics: DAE4 Sn1408; Calibrated: 9/14/2016

Phantom: SAM Front; Type: SAM; Serial: 1686

Measurement SW: DASY52, Version 52.8 (8); SEMCAD X Version 14.6.10 (7331)

835 MHz System Verification at 23.0 dBm (200 mW)

Area Scan (7x14x1): Measurement grid: dx=15mm, dy=15mm

Zoom Scan (5x5x7)/Cube 0: Measurement grid: dx=8mm, dy=8mm, dz=5mm

Peak SAR (extrapolated) = 2.80 W/kg

SAR(1 g) = 1.9 W/kg

Deviation(1 g) = 4.05%

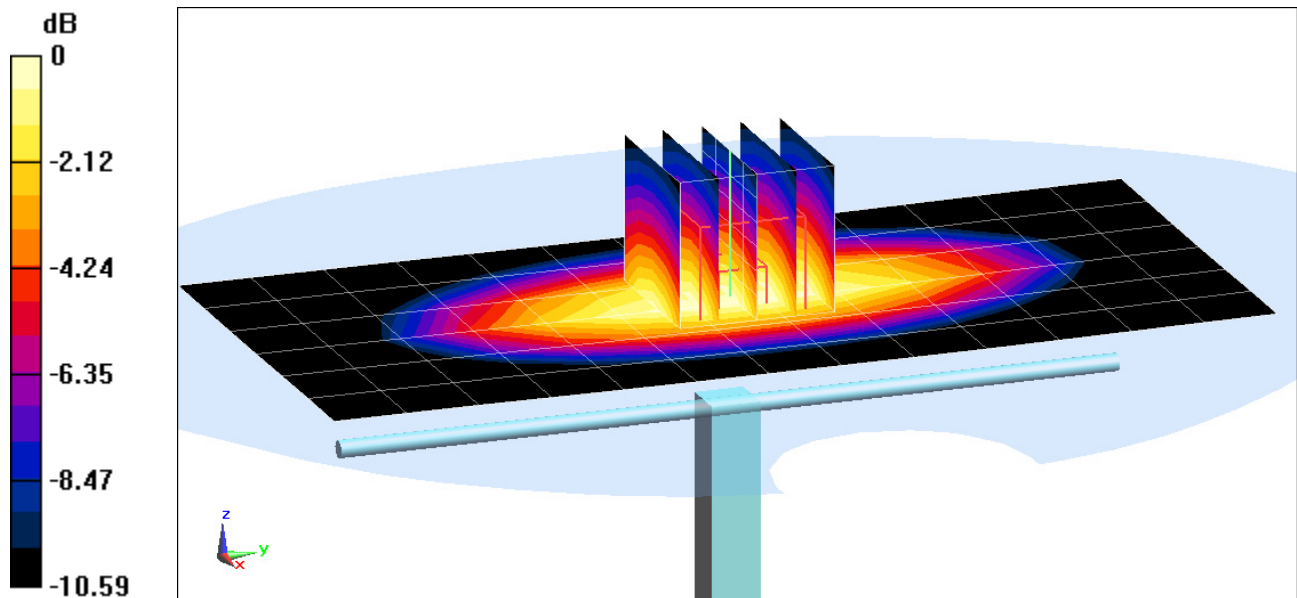

0 dB = 2.23 W/kg = 3.48 dBW/kg

PCTEST ENGINEERING LABORATORY, INC.

DUT: Dipole 1750 MHz; Type: D1750V2; Serial: 1148

Communication System: UID 0, CW; Frequency: 1750 MHz; Duty Cycle: 1:1

Medium: 1750 Head Medium parameters used:

$f = 1750 \text{ MHz}$; $\sigma = 1.36 \text{ S/m}$; $\epsilon_r = 38.821$; $\rho = 1000 \text{ kg/m}^3$

Phantom section: Flat Section; Space: 1.0 cm

Test Date: 01-27-2017; Ambient Temp: 24.0°C; Tissue Temp: 23.0°C

Probe: ES3DV3 - SN3209; ConvF(5.28, 5.28, 5.28); Calibrated: 3/18/2016;

Sensor-Surface: 3mm (Mechanical Surface Detection)

Electronics: DAE4 Sn1364; Calibrated: 8/22/2016

Phantom: SAM Front; Type: QD000P40CD; Serial: TP:1758

Measurement SW: DASY52, Version 52.8 (8); SEMCAD X Version 14.6.10 (7331)

1750 MHz System Verification at 20.0 dBm (100 mW)

Area Scan (7x9x1): Measurement grid: dx=15mm, dy=15mm

Zoom Scan (5x5x7)/Cube 0: Measurement grid: dx=8mm, dy=8mm, dz=5mm

Peak SAR (extrapolated) = 6.02 W/kg

SAR(1 g) = 3.37 W/kg

Deviation(1 g) = -6.91%

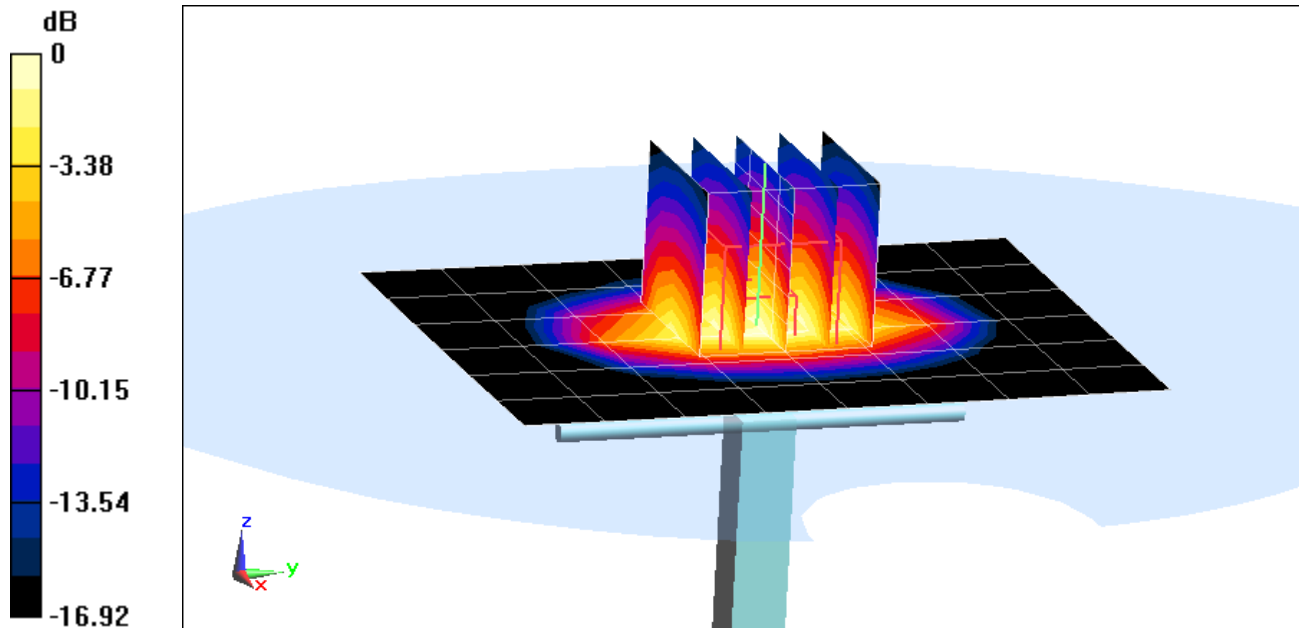

0 dB = 4.22 W/kg = 6.25 dBW/kg

PCTEST ENGINEERING LABORATORY, INC.

DUT: Dipole 1900 MHz; Type: D1900V2; Serial: 5d149

Communication System: UID 0, CW; Frequency: 1900 MHz; Duty Cycle: 1:1
Medium: 1900 Head Medium parameters used (interpolated):
 $f = 1900$ MHz; $\sigma = 1.453$ S/m; $\epsilon_r = 38.166$; $\rho = 1000$ kg/m³
Phantom section: Flat Section; Space: 1.0 cm

Test Date: 01-30-2017; Ambient Temp: 22.5°C; Tissue Temp: 21.5°C

Probe: ES3DV3 - SN3332; ConvF(5.45, 5.45, 5.45); Calibrated: 8/25/2016;
Sensor-Surface: 3mm (Mechanical Surface Detection)
Electronics: DAE4 Sn1333; Calibrated: 9/15/2016
Phantom: SAM Left; Type: SAM; Serial: 1688
Measurement SW: DASY52, Version 52.8 (8); SEMCAD X Version 14.6.10 (7331)

1900 MHz System Verification at 20.0 dBm (100 mW)

Area Scan (7x10x1): Measurement grid: dx=15mm, dy=15mm
Zoom Scan (5x5x7)/Cube 0: Measurement grid: dx=8mm, dy=8mm, dz=5mm
Peak SAR (extrapolated) = 7.11 W/kg
SAR(1 g) = 3.89 W/kg
Deviation(1 g) = -2.99%

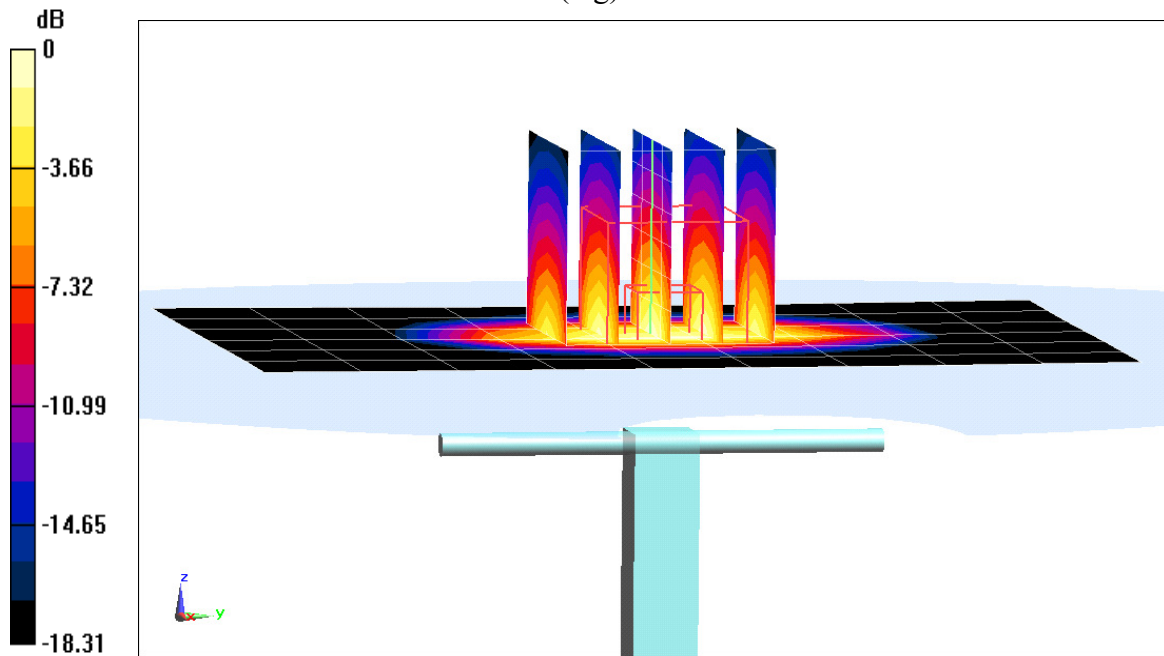

0 dB = 4.92 W/kg = 6.92 dBW/kg

PCTEST ENGINEERING LABORATORY, INC.

DUT: Dipole 2300 MHz; Type: D2300V2; Serial: 1064

Communication System: UID 0, CW; Frequency: 2300 MHz; Duty Cycle: 1:1

Medium: 2300 Head Medium parameters used:

$f = 2300 \text{ MHz}$; $\sigma = 1.695 \text{ S/m}$; $\epsilon_r = 38.794$; $\rho = 1000 \text{ kg/m}^3$

Phantom section: Flat Section; Space: 1.0 cm

Test Date: 01-22-2017; Ambient Temp: 23.2°C; Tissue Temp: 22.5°C

Probe: ES3DV3 - SN3287; ConvF(4.86, 4.86, 4.86); Calibrated: 9/19/2016;

Sensor-Surface: 3mm (Mechanical Surface Detection)

Electronics: DAE4 Sn1408; Calibrated: 9/14/2016

Phantom: SAM Front; Type: SAM; Serial: 1686

Measurement SW: DASY52, Version 52.8 (8); SEMCAD X Version 14.6.10 (7331)

2300 MHz System Verification at 20.0 dBm (100 mW)

Area Scan (8x9x1): Measurement grid: dx=12mm, dy=12mm

Zoom Scan (7x7x7)/Cube 0: Measurement grid: dx=5mm, dy=5mm, dz=5mm

Peak SAR (extrapolated) = 10.0 W/kg

SAR(1 g) = 4.96 W/kg

Deviation(1 g) = 2.48%

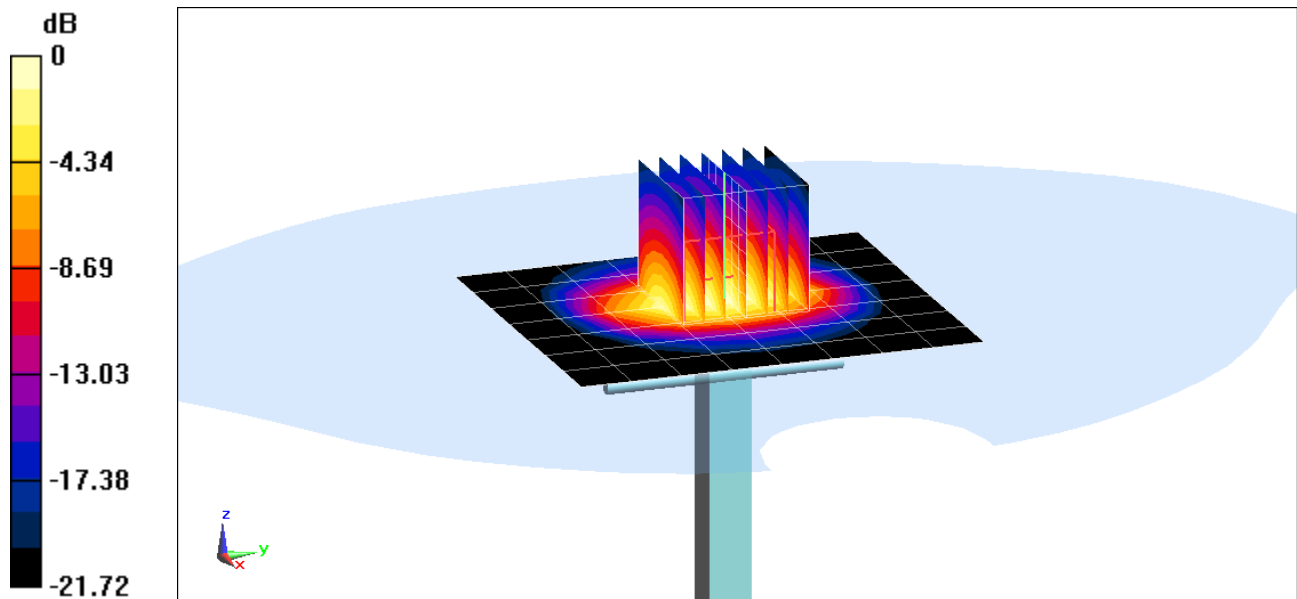

0 dB = 6.44 W/kg = 8.09 dBW/kg

PCTEST ENGINEERING LABORATORY, INC.

DUT: Dipole 2450 MHz; Type: D2450V2; Serial: 797

Communication System: UID 0, CW; Frequency: 2450 MHz; Duty Cycle: 1:1

Medium: 2450 Head Medium parameters used:

$f = 2450 \text{ MHz}$; $\sigma = 1.878 \text{ S/m}$; $\epsilon_r = 39.433$; $\rho = 1000 \text{ kg/m}^3$

Phantom section: Flat Section; Space: 1.0 cm

Test Date: 01-20-2017; Ambient Temp: 24.1°C; Tissue Temp: 23.1°C

Probe: ES3DV3 - SN3287; ConvF(4.54, 4.54, 4.54); Calibrated: 9/19/2016;

Sensor-Surface: 3mm (Mechanical Surface Detection)

Electronics: DAE4 Sn1408; Calibrated: 9/14/2016

Phantom: SAM Front; Type: SAM; Serial: 1686

Measurement SW: DASY52, Version 52.8 (8); SEMCAD X Version 14.6.10 (7331)

2450 MHz System Verification at 20.0 dBm (100 mW)

Area Scan (8x9x1): Measurement grid: dx=12mm, dy=12mm

Zoom Scan (7x8x7)/Cube 0: Measurement grid: dx=5mm, dy=5mm, dz=5mm

Peak SAR (extrapolated) = 11.6 W/kg

SAR(1 g) = 5.50 W/kg

Deviation(1 g) = 5.57%

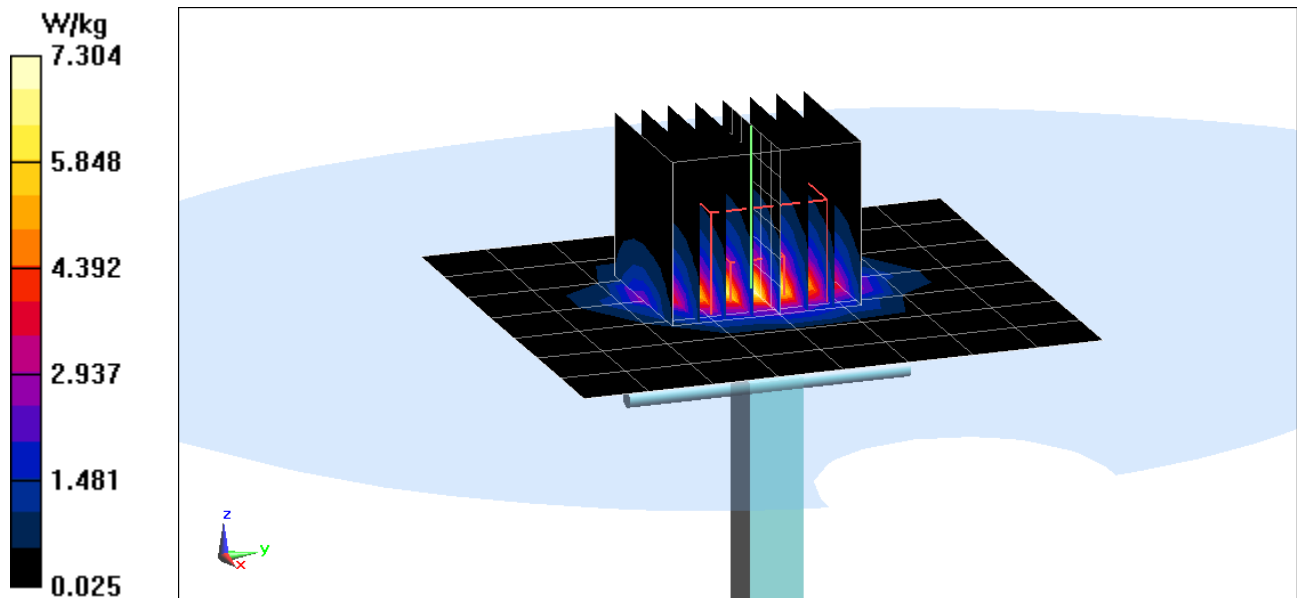

PCTEST ENGINEERING LABORATORY, INC.

DUT: Dipole 2600 MHz; Type: D2600V2; Serial: 1071

Communication System: UID 0, CW; Frequency: 2600 MHz; Duty Cycle: 1:1

Medium: 2600 Head Medium parameters used:

$f = 2600$ MHz; $\sigma = 2.042$ S/m; $\epsilon_r = 37.518$; $\rho = 1000$ kg/m³

Phantom section: Flat Section; Space: 1.0 cm

Test Date: 01-22-2017; Ambient Temp: 23.2°C; Tissue Temp: 22.5°C

Probe: ES3DV3 - SN3287; ConvF(4.41, 4.41, 4.41); Calibrated: 9/19/2016;

Sensor-Surface: 3mm (Mechanical Surface Detection)

Electronics: DAE4 Sn1408; Calibrated: 9/14/2016

Phantom: SAM Front; Type: SAM; Serial: 1686

Measurement SW: DASY52, Version 52.8 (8); SEMCAD X Version 14.6.10 (7331)

2600 MHz System Verification at 20.0 dBm (100 mW)

Area Scan (8x9x1): Measurement grid: dx=12mm, dy=12mm

Zoom Scan (7x7x7)/Cube 0: Measurement grid: dx=5mm, dy=5mm, dz=5mm

Peak SAR (extrapolated) = 12.8 W/kg

SAR(1 g) = 5.61 W/kg

Deviation(1 g) = -0.36%

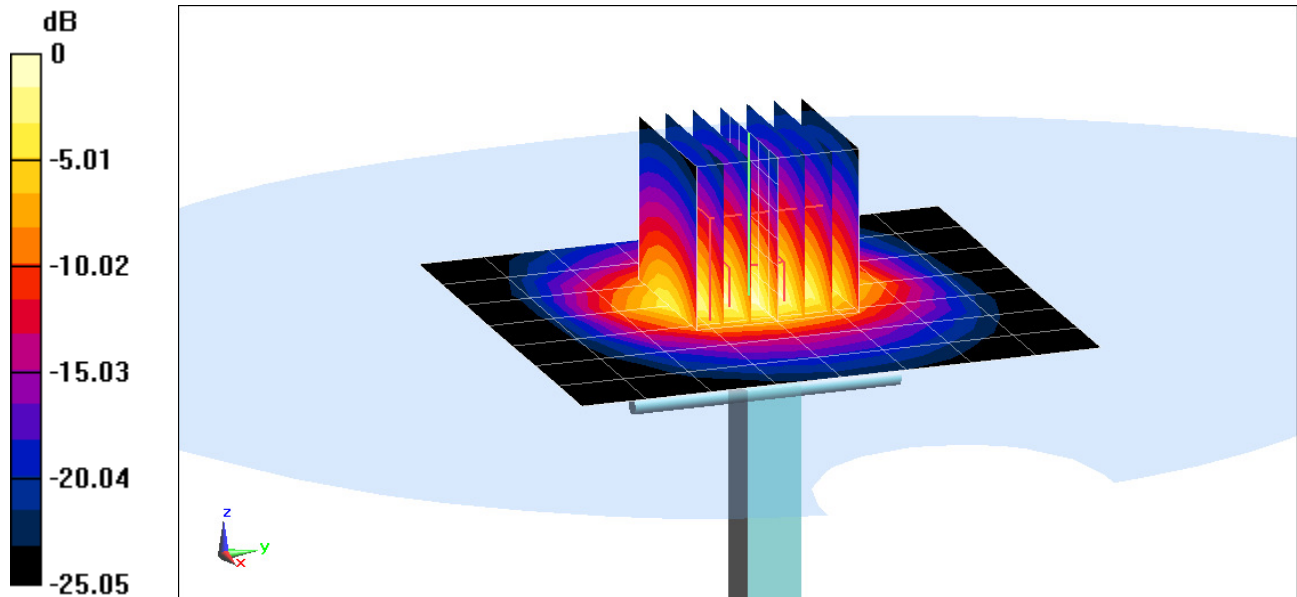

0 dB = 7.56 W/kg = 8.79 dBW/kg

PCTEST ENGINEERING LABORATORY, INC.

DUT: Dipole 5 GHz; Type: D5GHzV2; Serial: 1191

Communication System: UID 0, CW; Frequency: 5250 MHz; Duty Cycle: 1:1

Medium: 5 GHz Head Medium parameters used (interpolated):

$f = 5250$ MHz; $\sigma = 4.572$ S/m; $\epsilon_r = 34.988$; $\rho = 1000$ kg/m³

Phantom section: Flat Section; Space: 1.0 cm

Test Date: 01-23-2017; Ambient Temp: 20.9°C; Tissue Temp: 20.3°C

Probe: EX3DV4 - SN7357; ConvF(5.1, 5.1, 5.1); Calibrated: 4/19/2016;

Sensor-Surface: 1.4mm (Mechanical Surface Detection)

Electronics: DAE4 Sn665; Calibrated: 2/19/2016

Phantom: SAM with CRP v4.0; Type: QD000P40CD; Serial: TP:1800

Measurement SW: DASY52, Version 52.8 (8); SEMCAD X Version 14.6.10 (7331)

5250 MHz System Verification at 17.0 dBm (50 mW)

Area Scan (7x7x1): Measurement grid: dx=10mm, dy=10mm

Zoom Scan (8x8x7)/Cube 0: Measurement grid: dx=4mm, dy=4mm, dz=1.4mm; Graded Ratio: 1.4

Peak SAR (extrapolated) = 16.0 W/kg

SAR(1 g) = 3.88 W/kg

Deviation(1 g) = -1.65%

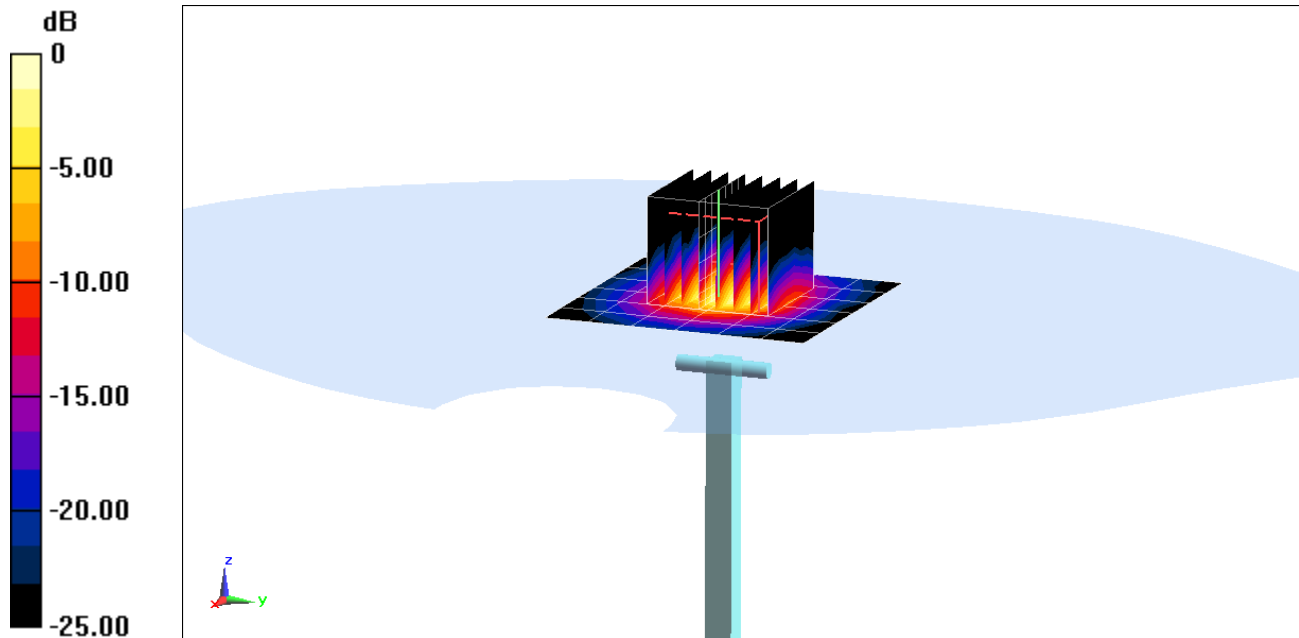

0 dB = 9.08 W/kg = 9.58 dBW/kg

PCTEST ENGINEERING LABORATORY, INC.

DUT: Dipole 5 GHz; Type: D5GHzV2; Serial: 1191

Communication System: UID 0, CW; Frequency: 5600 MHz; Duty Cycle: 1:1

Medium: 5 GHz Head Medium parameters used:

$f = 5600 \text{ MHz}$; $\sigma = 4.914 \text{ S/m}$; $\epsilon_r = 34.502$; $\rho = 1000 \text{ kg/m}^3$

Phantom section: Flat Section; Space: 1.0 cm

Test Date: 01-23-2017; Ambient Temp: 20.9°C; Tissue Temp: 20.3°C

Probe: EX3DV4 - SN7357; ConvF(4.41, 4.41, 4.41); Calibrated: 4/19/2016;

Sensor-Surface: 1.4mm (Mechanical Surface Detection)

Electronics: DAE4 Sn665; Calibrated: 2/19/2016

Phantom: SAM with CRP v4.0; Type: QD000P40CD; Serial: TP:1800

Measurement SW: DASY52, Version 52.8 (8); SEMCAD X Version 14.6.10 (7331)

5600 MHz System Verification at 17.0 dBm (50 mW)

Area Scan (7x7x1): Measurement grid: dx=10mm, dy=10mm

Zoom Scan (8x8x7)/Cube 0: Measurement grid: dx=4mm, dy=4mm, dz=1.4mm; Graded Ratio: 1.4

Peak SAR (extrapolated) = 17.2 W/kg

SAR(1 g) = 4.12 W/kg

Deviation(1 g) = -1.44%

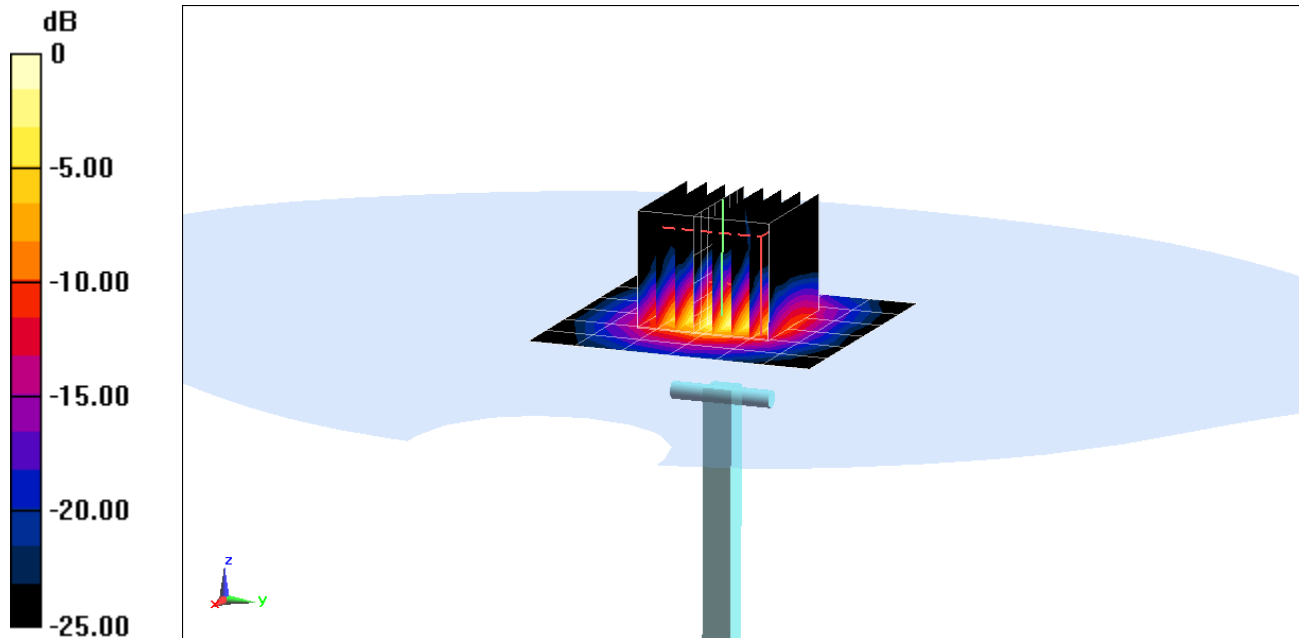

0 dB = 10.1 W/kg = 10.04 dBW/kg

PCTEST ENGINEERING LABORATORY, INC.

DUT: Dipole 5 GHz; Type: D5GHzV2; Serial: 1191

Communication System: UID 0, CW; Frequency: 5750 MHz; Duty Cycle: 1:1

Medium: 5 GHz Head Medium parameters used (interpolated):

$f = 5750 \text{ MHz}$; $\sigma = 5.074 \text{ S/m}$; $\epsilon_r = 34.319$; $\rho = 1000 \text{ kg/m}^3$

Phantom section: Flat Section; Space: 1.0 cm

Test Date: 01-23-2017; Ambient Temp: 20.9°C; Tissue Temp: 20.3°C

Probe: EX3DV4 - SN7357; ConvF(4.65, 4.65, 4.65); Calibrated: 4/19/2016;

Sensor-Surface: 1.4mm (Mechanical Surface Detection)

Electronics: DAE4 Sn665; Calibrated: 2/19/2016

Phantom: SAM with CRP v4.0; Type: QD000P40CD; Serial: TP:1800

Measurement SW: DASY52, Version 52.8 (8); SEMCAD X Version 14.6.10 (7331)

5750 MHz System Verification at 17.0 dBm (50 mW)

Area Scan (7x7x1): Measurement grid: dx=10mm, dy=10mm

Zoom Scan (8x8x7)/Cube 0: Measurement grid: dx=4mm, dy=4mm, dz=1.4mm; Graded Ratio: 1.4

Peak SAR (extrapolated) = 17.0 W/kg

SAR(1 g) = 3.91 W/kg

Deviation(1 g) = -1.14%

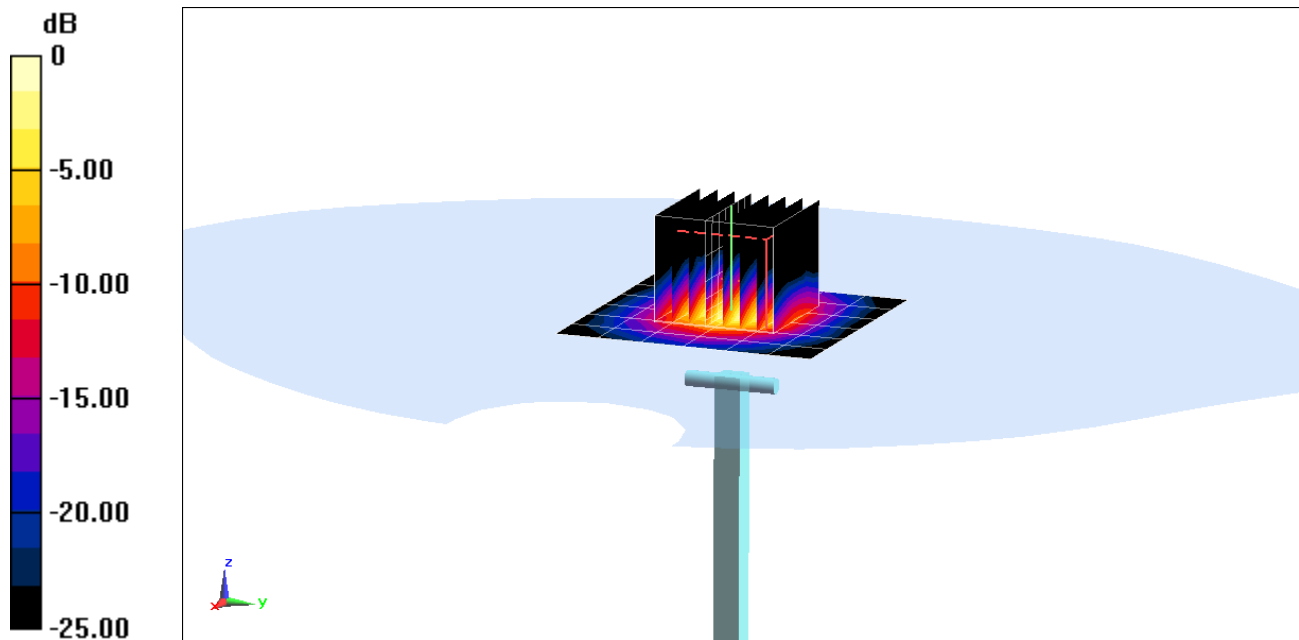

0 dB = 9.67 W/kg = 9.85 dBW/kg

PCTEST ENGINEERING LABORATORY, INC.

DUT: Dipole 750 MHz; Type: D750V3; Serial: 1161

Communication System: UID 0, CW; Frequency: 750 MHz; Duty Cycle: 1:1

Medium: 750 Body Medium parameters used (interpolated):

$f = 750 \text{ MHz}$; $\sigma = 0.961 \text{ S/m}$; $\epsilon_r = 54.452$; $\rho = 1000 \text{ kg/m}^3$

Phantom section: Flat Section; Space: 1.5 cm

Test Date: 01-30-2017; Ambient Temp: 22.7°C; Tissue Temp: 20.8°C

Probe: ES3DV3 - SN3209; ConvF(6.19, 6.19, 6.19); Calibrated: 3/18/2016;

Sensor-Surface: 3mm (Mechanical Surface Detection)

Electronics: DAE4 Sn1364; Calibrated: 8/22/2016

Phantom: SAM Front; Type: QD000P40CD; Serial: TP:1758

Measurement SW: DASY52, Version 52.8 (8); SEMCAD X Version 14.6.10 (7331)

750 MHz System Verification at 23.0 dBm (200 mW)

Area Scan (7x15x1): Measurement grid: dx=15mm, dy=15mm

Zoom Scan (5x5x7)/Cube 0: Measurement grid: dx=8mm, dy=8mm, dz=5mm

Peak SAR (extrapolated) = 2.57 W/kg

SAR(1 g) = 1.76 W/kg

Deviation(1 g) = 4.39%

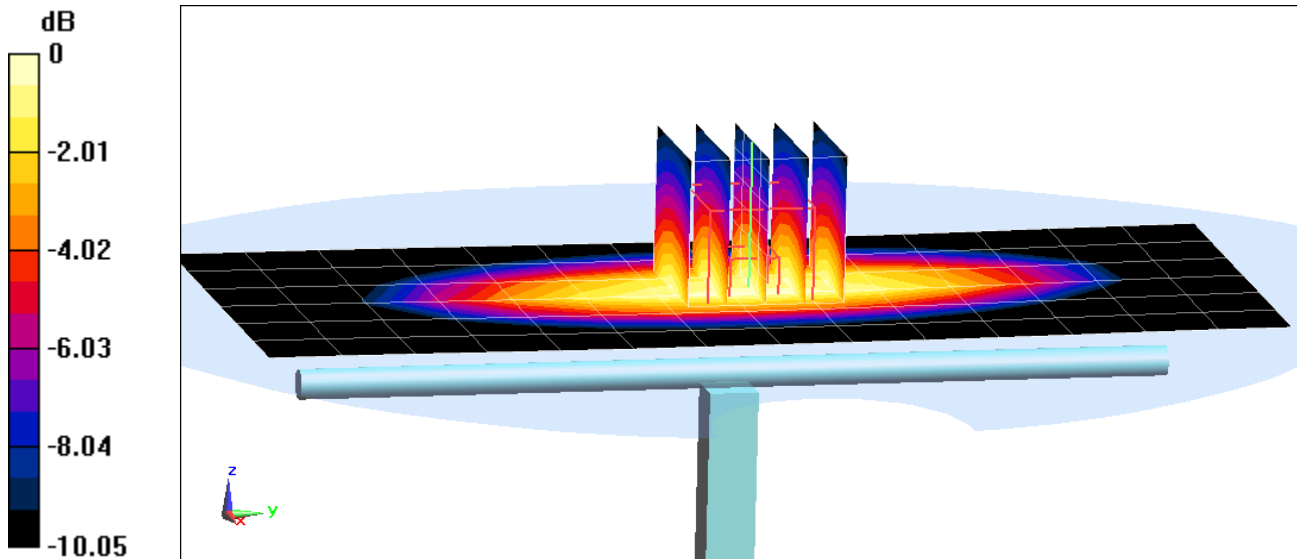

0 dB = 2.05 W/kg = 3.12 dBW/kg

PCTEST ENGINEERING LABORATORY, INC.

DUT: Dipole 835 MHz; Type: D835V2; Serial: 4d047

Communication System: UID 0, CW; Frequency: 835 MHz; Duty Cycle: 1:1

Medium: 835 Body Medium parameters used:

$f = 835 \text{ MHz}$; $\sigma = 0.999 \text{ S/m}$; $\epsilon_r = 55.523$; $\rho = 1000 \text{ kg/m}^3$

Phantom section: Flat Section; Space: 1.5 cm

Test Date: 01-30-2017; Ambient Temp: 22.8°C; Tissue Temp: 21.1°C

Probe: ES3DV3 - SN3319; ConvF(6.04, 6.04, 6.04); Calibrated: 3/18/2016;

Sensor-Surface: 3mm (Mechanical Surface Detection)

Electronics: DAE4 Sn1368; Calibrated: 3/14/2016

Phantom: SAM with CRP (Left); Type: SAM; Serial: 1715

Measurement SW: DASY52, Version 52.8 (8); SEMCAD X Version 14.6.10 (7331)

835 MHz System Verification at 23.0 dBm (200 mW)

Area Scan (7x14x1): Measurement grid: dx=15mm, dy=15mm

Zoom Scan (5x5x7)/Cube 0: Measurement grid: dx=8mm, dy=8mm, dz=5mm

Peak SAR (extrapolated) = 2.86 W/kg

SAR(1 g) = 1.95 W/kg

Deviation(1 g) = 1.88%

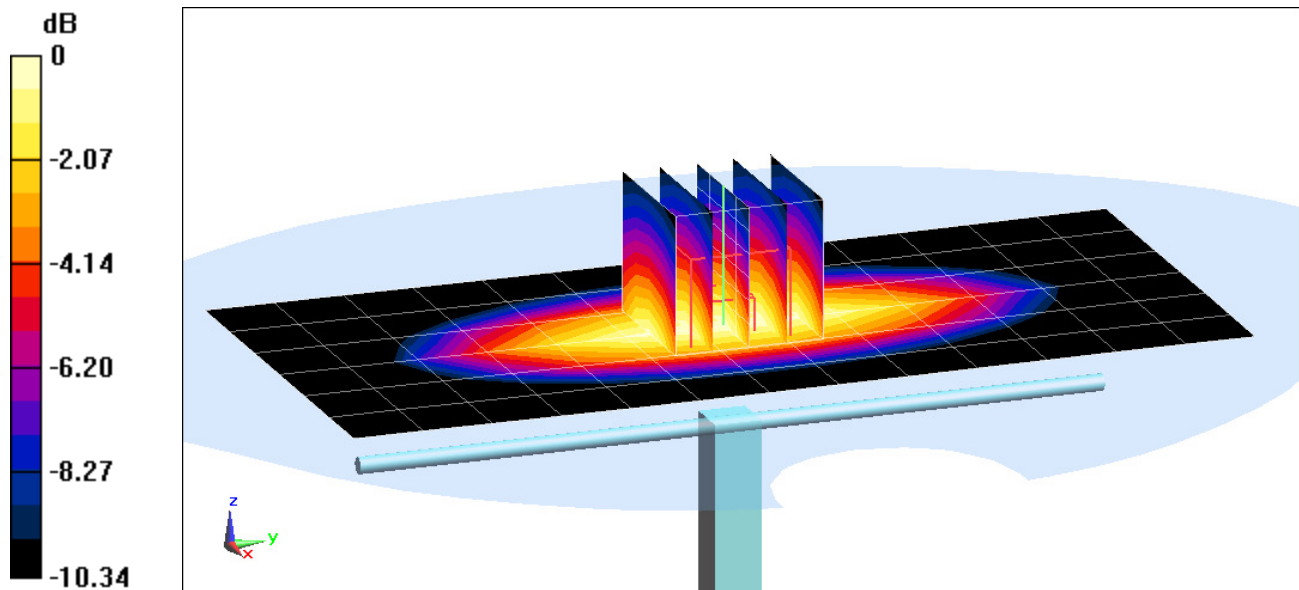

0 dB = 2.28 W/kg = 3.58 dBW/kg

PCTEST ENGINEERING LABORATORY, INC.

DUT: Dipole 1750 MHz; Type: D1750V2; Serial: 1148

Communication System: UID 0, CW; Frequency: 1750 MHz; Duty Cycle: 1:1

Medium: 1750 Body Medium parameters used:

$f = 1750 \text{ MHz}$; $\sigma = 1.506 \text{ S/m}$; $\epsilon_r = 51.573$; $\rho = 1000 \text{ kg/m}^3$

Phantom section: Flat Section; Space: 1.0 cm

Test Date: 01-23-2017; Ambient Temp: 23.6°C; Tissue Temp: 23.0°C

Probe: ES3DV3 - SN3209; ConvF(4.99, 4.99, 4.99); Calibrated: 3/18/2016;

Sensor-Surface: 3mm (Mechanical Surface Detection)

Electronics: DAE4 Sn1364; Calibrated: 8/22/2016

Phantom: SAM Front; Type: QD000P40CD; Serial: TP:1758

Measurement SW: DASY52, Version 52.8 (8); SEMCAD X Version 14.6.10 (7331)

1750 MHz System Verification at 20.0 dBm (100 mW)

Area Scan (7x9x1): Measurement grid: dx=15mm, dy=15mm

Zoom Scan (5x5x7)/Cube 0: Measurement grid: dx=8mm, dy=8mm, dz=5mm

Peak SAR (extrapolated) = 6.96 W/kg

SAR(1 g) = 3.93 W/kg

Deviation(1 g) = 5.93%

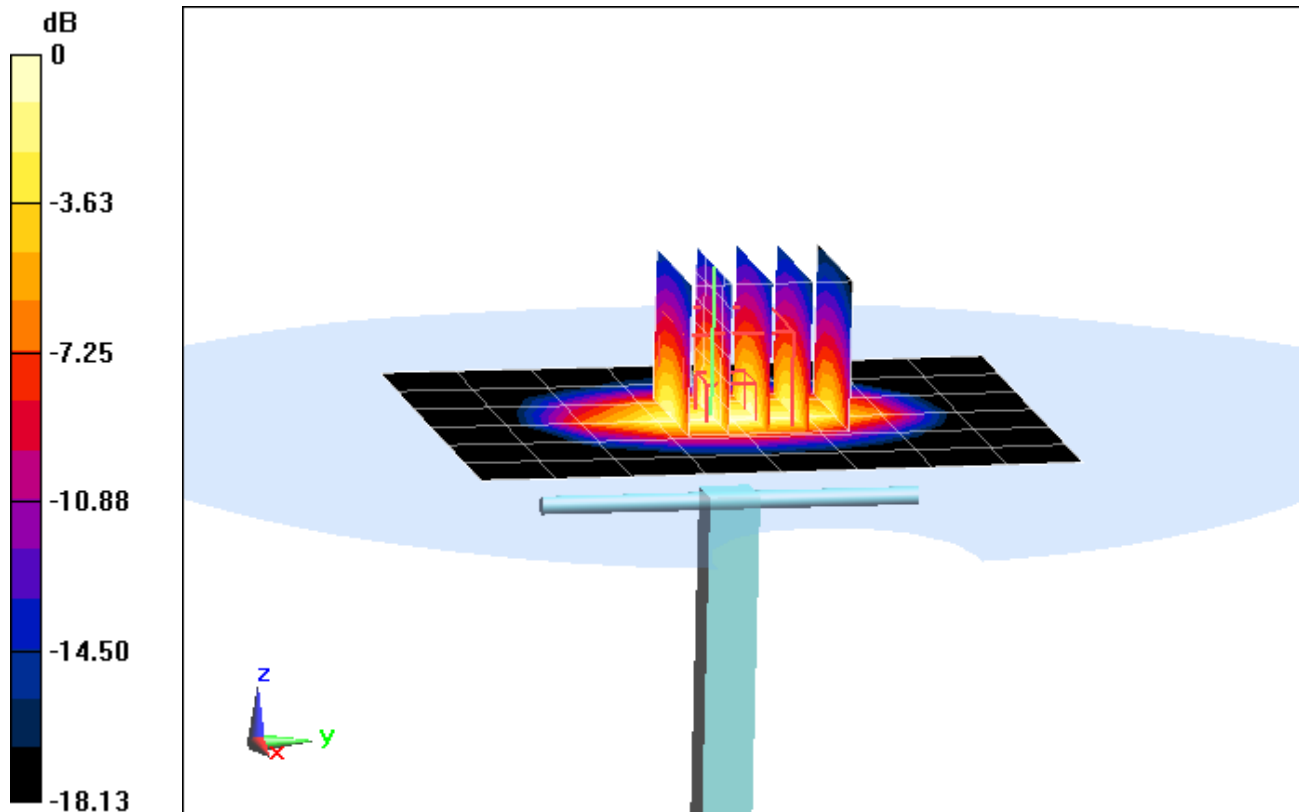

0 dB = 4.81 W/kg = 6.82 dBW/kg

PCTEST ENGINEERING LABORATORY, INC.

DUT: Dipole 1750 MHz; Type: D1750V2; Serial: 1148

Communication System: UID 0, CW; Frequency: 1750 MHz; Duty Cycle: 1:1

Medium: 1750 Body Medium parameters used:

$f = 1750 \text{ MHz}$; $\sigma = 1.488 \text{ S/m}$; $\epsilon_r = 52.205$; $\rho = 1000 \text{ kg/m}^3$

Phantom section: Flat Section; Space: 1.0 cm

Test Date: 01-27-2017; Ambient Temp: 23.2°C; Tissue Temp: 21.6°C

Probe: ES3DV3 - SN3213; ConvF(4.94, 4.94, 4.94); Calibrated: 2/19/2016;

Sensor-Surface: 3mm (Mechanical Surface Detection)

Electronics: DAE4 Sn1272; Calibrated: 2/18/2016

Phantom: SAM with CRP v5.0 Left; Type: QD000P40CD; Serial: 1687

Measurement SW: DASY52, Version 52.8 (8); SEMCAD X Version 14.6.10 (7331)

1750 MHz System Verification at 20.0 dBm (100 mW)

Area Scan (7x9x1): Measurement grid: dx=15mm, dy=15mm

Zoom Scan (5x6x7)/Cube 0: Measurement grid: dx=8mm, dy=8mm, dz=5mm

Peak SAR (extrapolated) = 6.23 W/kg

SAR(1 g) = 3.57 W/kg

Deviation(1 g) = -3.77%

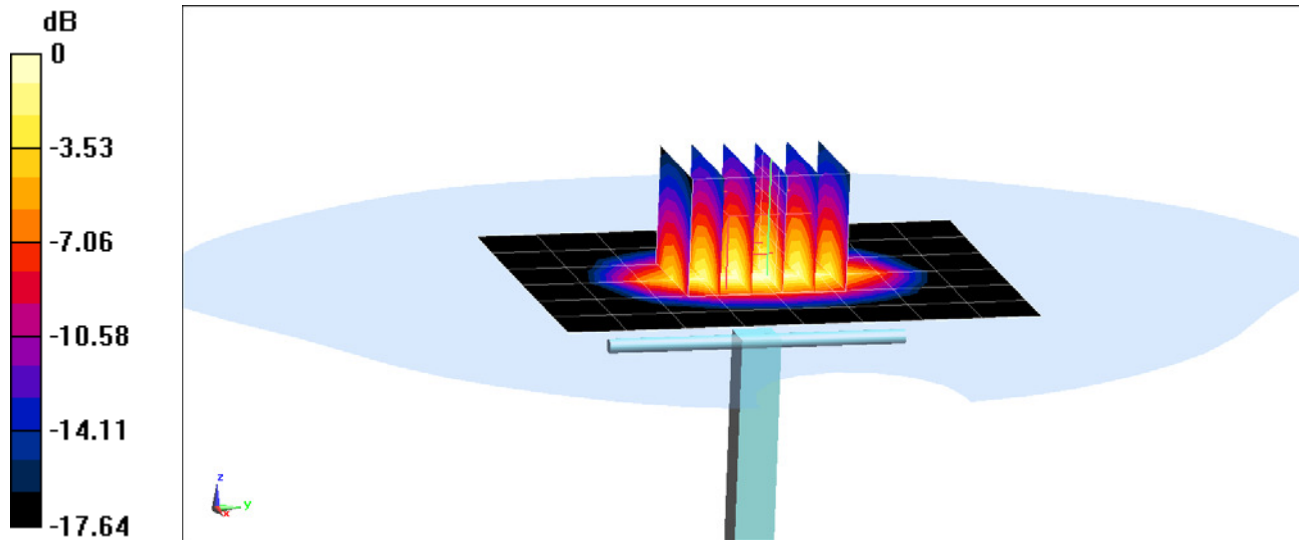

0 dB = 4.46 W/kg = 6.49 dBW/kg

PCTEST ENGINEERING LABORATORY, INC.

DUT: Dipole 1900 MHz; Type: D1900V2; Serial: 5d149

Communication System: UID 0, CW; Frequency: 1900 MHz; Duty Cycle: 1:1

Medium: 1900 Body Medium parameters used (interpolated):

$f = 1900$ MHz; $\sigma = 1.533$ S/m; $\epsilon_r = 51.926$; $\rho = 1000$ kg/m³

Phantom section: Flat Section; Space: 1.0 cm

Test Date: 01-23-2017; Ambient Temp: 23.9°C; Tissue Temp: 23.4°C

Probe: EX3DV4 - SN7409; ConvF(7.47, 7.47, 7.47); Calibrated: 5/17/2016;

Sensor-Surface: 1.4mm (Mechanical Surface Detection)

Electronics: DAE4 Sn859; Calibrated: 5/11/2016

Phantom: SAM Left; Type: QD000P40CC; Serial: TP: 1375

Measurement SW: DASY52, Version 52.8 (8); SEMCAD X Version 14.6.10 (7331)

1900 MHz System Verification at 20.0 dBm (100 mW)

Area Scan (7x11x1): Measurement grid: dx=15mm, dy=15mm

Zoom Scan (5x5x7)/Cube 0: Measurement grid: dx=8mm, dy=8mm, dz=5mm

Peak SAR (extrapolated) = 7.33 W/kg

SAR(1 g) = 3.93 W/kg

Deviation(1 g) = -1.50%

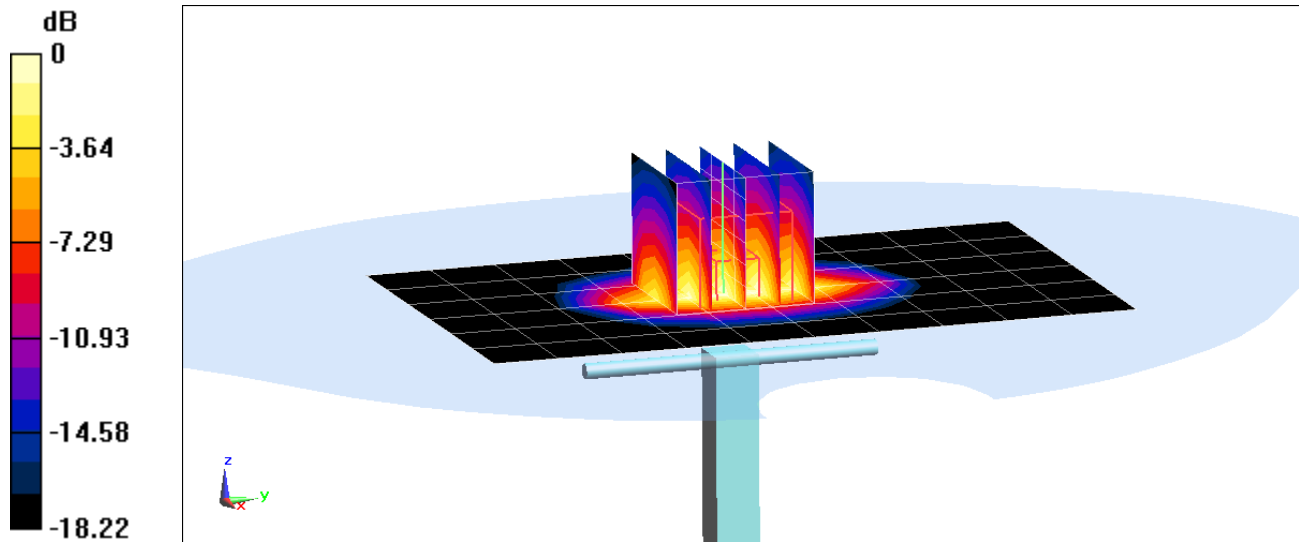

0 dB = 6.13 W/kg = 7.87 dBW/kg

PCTEST ENGINEERING LABORATORY, INC.

DUT: Dipole 1900 MHz; Type: D1900V2; Serial: 5d080

Communication System: UID 0, CW; Frequency: 1900 MHz; Duty Cycle: 1:1

Medium: 1900 Body Medium parameters used (interpolated):

$f = 1900$ MHz; $\sigma = 1.559$ S/m; $\epsilon_r = 52.151$; $\rho = 1000$ kg/m³

Phantom section: Flat Section; Space: 1.0 cm

Test Date: 01-25-2017; Ambient Temp: 24.0°C; Tissue Temp: 21.5°C

Probe: EX3DV4 - SN7409; ConvF(7.47, 7.47, 7.47); Calibrated: 5/17/2016;

Sensor-Surface: 1.4mm (Mechanical Surface Detection)

Electronics: DAE4 Sn859; Calibrated: 5/11/2016

Phantom: SAM Left; Type: QD000P40CC; Serial: TP: 1375

Measurement SW: DASY52, Version 52.8 (8); SEMCAD X Version 14.6.10 (7331)

1900 MHz System Verification at 20.0 dBm (100 mW)

Area Scan (7x11x1): Measurement grid: dx=15mm, dy=15mm

Zoom Scan (5x5x7)/Cube 0: Measurement grid: dx=8mm, dy=8mm, dz=5mm

Peak SAR (extrapolated) = 7.37 W/kg

SAR(1 g) = 3.98 W/kg

Deviation(1 g) = 1.79%

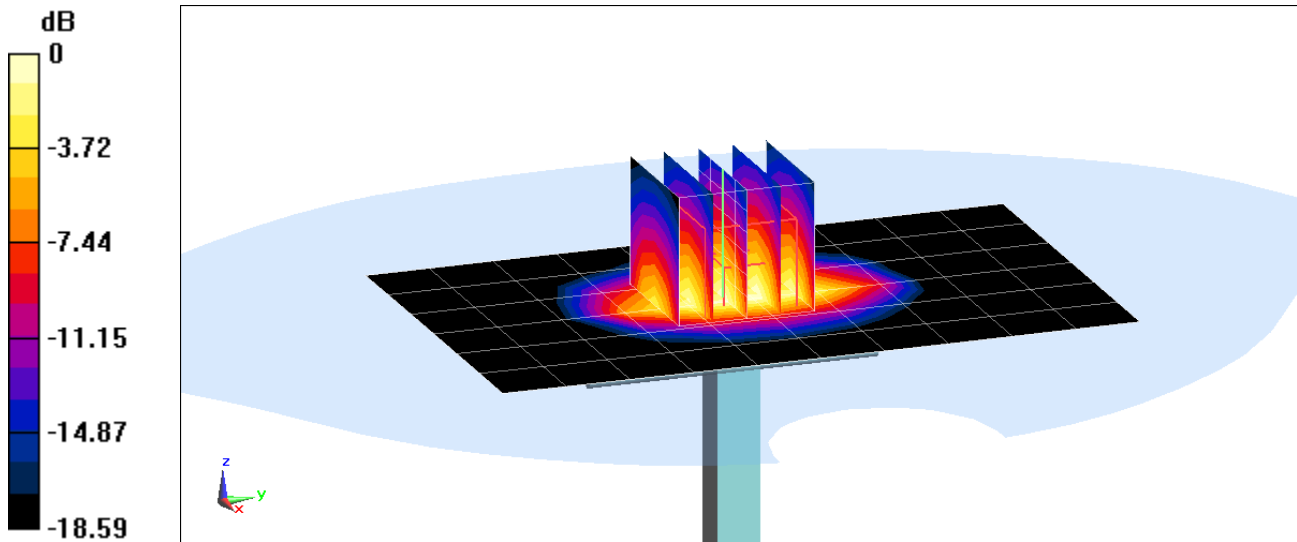

0 dB = 6.13 W/kg = 7.87 dBW/kg

PCTEST ENGINEERING LABORATORY, INC.

DUT: Dipole 1900 MHz; Type: D1900V2; Serial: 5d080

Communication System: UID 0, CW; Frequency: 1900 MHz; Duty Cycle: 1:1

Medium: 1900 Body Medium parameters used (interpolated):

$f = 1900 \text{ MHz}$; $\sigma = 1.577 \text{ S/m}$; $\epsilon_r = 51.199$; $\rho = 1000 \text{ kg/m}^3$

Phantom section: Flat Section; Space: 1.0 cm

Test Date: 01-30-2017; Ambient Temp: 20.9°C; Tissue Temp: 21.5°C

Probe: EX3DV4 - SN7357; ConvF(7.84, 7.84, 7.84); Calibrated: 4/19/2016;

Sensor-Surface: 1.4mm (Mechanical Surface Detection)

Electronics: DAE4 Sn665; Calibrated: 2/19/2016

Phantom: SAM with CRP v4.0 Left; Type: QD000P40CD; Serial: TP:1692

Measurement SW: DASY52, Version 52.8 (8); SEMCAD X Version 14.6.10 (7331)

1900 MHz System Verification at 20.0 dBm (100 mW)

Area Scan (7x11x1): Measurement grid: dx=15mm, dy=15mm

Zoom Scan (6x6x8)/Cube 0: Measurement grid: dx=8mm, dy=8mm, dz=5mm

Peak SAR (extrapolated) = 7.84 W/kg

SAR(1 g) = 4.18 W/kg

Deviation(1 g) = 6.91%

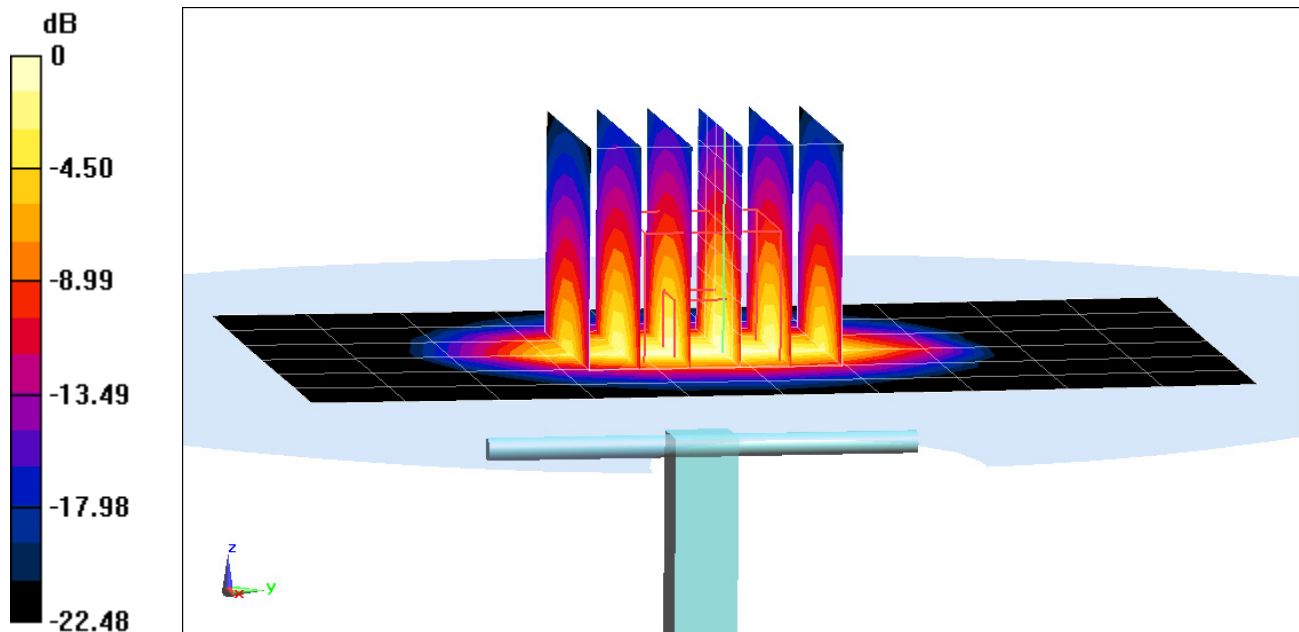

0 dB = 6.14 W/kg = 7.88 dBW/kg

PCTEST ENGINEERING LABORATORY, INC.

DUT: Dipole 2300 MHz; Type: D2300V2; Serial: 1064

Communication System: UID 0, CW; Frequency: 2300 MHz; Duty Cycle: 1:1

Medium: 2300 Body Medium parameters used:

$f = 2300 \text{ MHz}$; $\sigma = 1.833 \text{ S/m}$; $\epsilon_r = 52.814$; $\rho = 1000 \text{ kg/m}^3$

Phantom section: Flat Section; Space: 1.0 cm

Test Date: 01-30-2017; Ambient Temp: 22.5°C; Tissue Temp: 21.5°C

Probe: EX3DV4 - SN7406; ConvF(7.37, 7.37, 7.37); Calibrated: 4/19/2016;

Sensor-Surface: 1.4mm (Mechanical Surface Detection)

Electronics: DAE4 Sn1407; Calibrated: 4/14/2016

Phantom: SAM 5.0 front; Type: QD000P40CD; Serial: TP:-1648

Measurement SW: DASY52, Version 52.8 (8); SEMCAD X Version 14.6.10 (7331)

2300 MHz System Verification at 20.0 dBm (100 mW)

Area Scan (8x9x1): Measurement grid: dx=12mm, dy=12mm

Zoom Scan (7x7x7)/Cube 0: Measurement grid: dx=5mm, dy=5mm, dz=5mm

Peak SAR (extrapolated) = 9.28 W/kg

SAR(1 g) = 4.64 W/kg

Deviation(1 g) = -1.28%

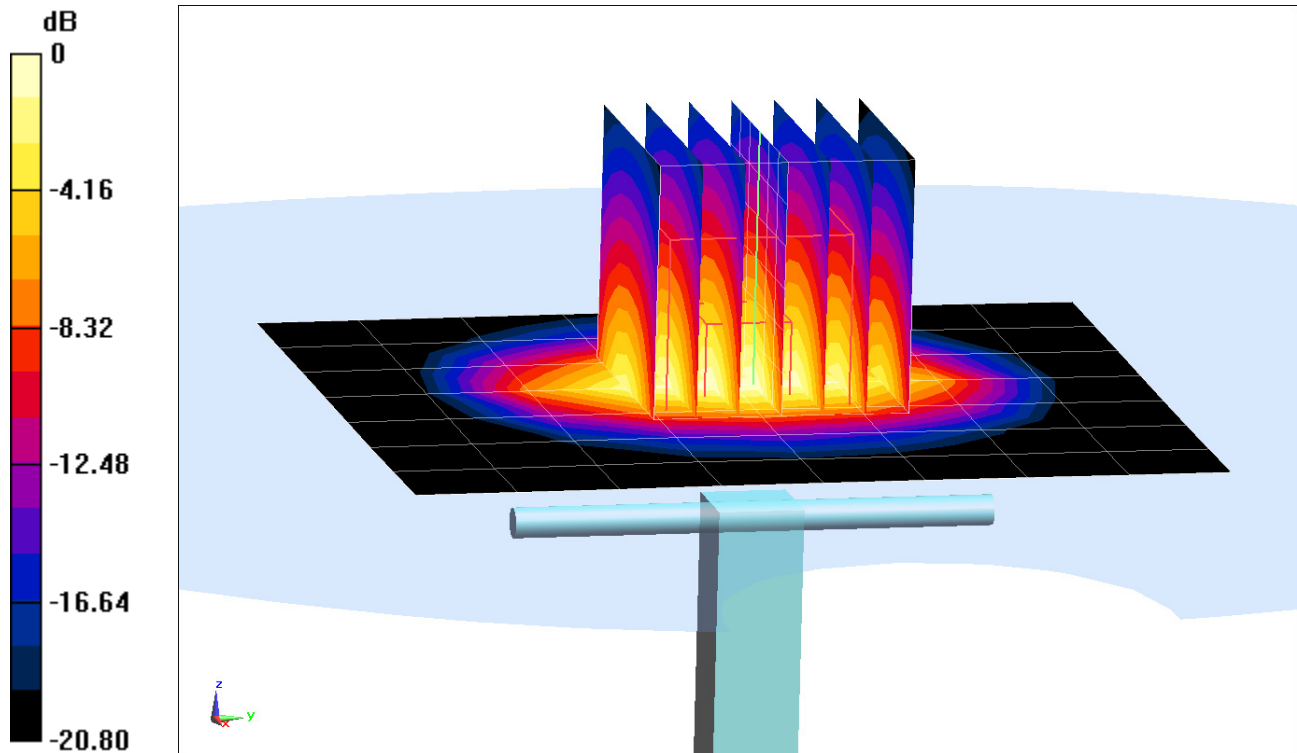

0 dB = 7.54 W/kg = 8.77 dBW/kg

PCTEST ENGINEERING LABORATORY, INC.

DUT: Dipole 2450 MHz; Type: D2450V2; Serial: 981

Communication System: UID 0, CW; Frequency: 2450 MHz; Duty Cycle: 1:1

Medium: 2450 Body Medium parameters used:

$f = 2450$ MHz; $\sigma = 1.973$ S/m; $\epsilon_r = 51.355$; $\rho = 1000$ kg/m³

Phantom section: Flat Section; Space: 1.0 cm

Test Date: 01-24-2017; Ambient Temp: 24.0°C; Tissue Temp: 23.0°C

Probe: EX3DV4 - SN7406; ConvF(7.24, 7.24, 7.24); Calibrated: 4/19/2016;

Sensor-Surface: 1.4mm (Mechanical Surface Detection)

Electronics: DAE4 Sn1407; Calibrated: 4/14/2016

Phantom: SAM 5.0 front; Type: QD000P40CD; Serial: TP:-1648

Measurement SW: DASY52, Version 52.8 (8); SEMCAD X Version 14.6.10 (7331)

2450 MHz System Verification at 20.0 dBm (100 mW)

Area Scan (8x9x1): Measurement grid: dx=12mm, dy=12mm

Zoom Scan (7x7x7)/Cube 0: Measurement grid: dx=5mm, dy=5mm, dz=5mm

Peak SAR (extrapolated) = 10.1 W/kg

SAR(1 g) = 4.94 W/kg

Deviation(1 g) = -2.76%

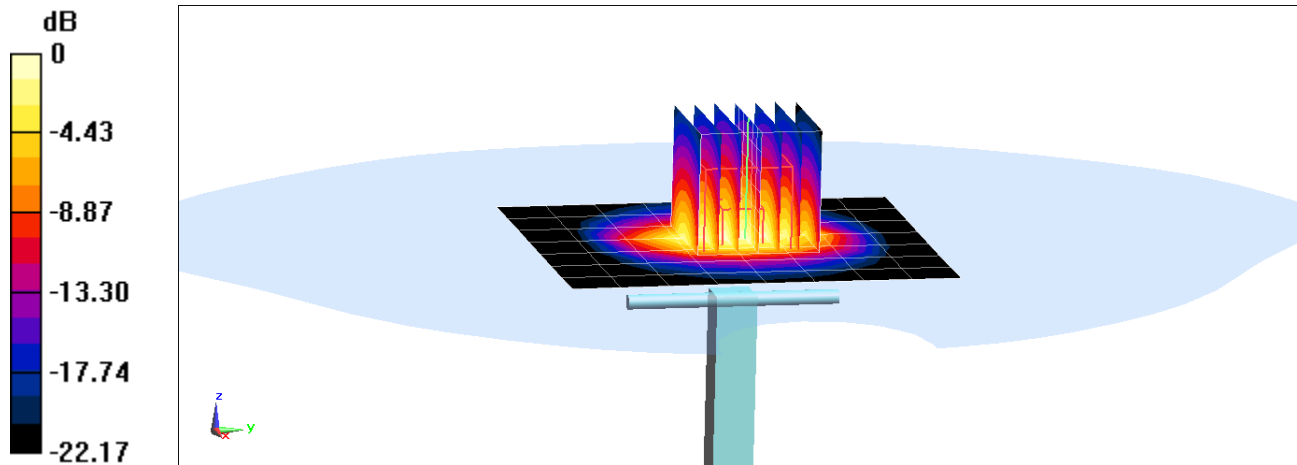

0 dB = 8.19 W/kg = 9.13 dBW/kg

PCTEST ENGINEERING LABORATORY, INC.

DUT: Dipole 2600 MHz; Type: D2600V2; Serial: 1071

Communication System: UID 0, CW; Frequency: 2600 MHz; Duty Cycle: 1:1

Medium: 2600 Body Medium parameters used:

$f = 2600 \text{ MHz}$; $\sigma = 2.25 \text{ S/m}$; $\epsilon_r = 51.689$; $\rho = 1000 \text{ kg/m}^3$

Phantom section: Flat Section; Space: 1.0 cm

Test Date: 01-30-2017; Ambient Temp: 22.5°C; Tissue Temp: 21.5°C

Probe: EX3DV4 - SN7406; ConvF(6.94, 6.94, 6.94); Calibrated: 4/19/2016;

Sensor-Surface: 1.4mm (Mechanical Surface Detection)

Electronics: DAE4 Sn1407; Calibrated: 4/14/2016

Phantom: SAM 5.0 front; Type: QD000P40CD; Serial: TP:-1648

Measurement SW: DASY52, Version 52.8 (8); SEMCAD X Version 14.6.10 (7331)

2600 MHz System Verification at 20.0 dBm (100 mW)

Area Scan (8x9x1): Measurement grid: dx=12mm, dy=12mm

Zoom Scan (7x7x7)/Cube 0: Measurement grid: dx=5mm, dy=5mm, dz=5mm

Peak SAR (extrapolated) = 12.9 W/kg

SAR(1 g) = 5.79 W/kg

Deviation(1 g) = 6.83%

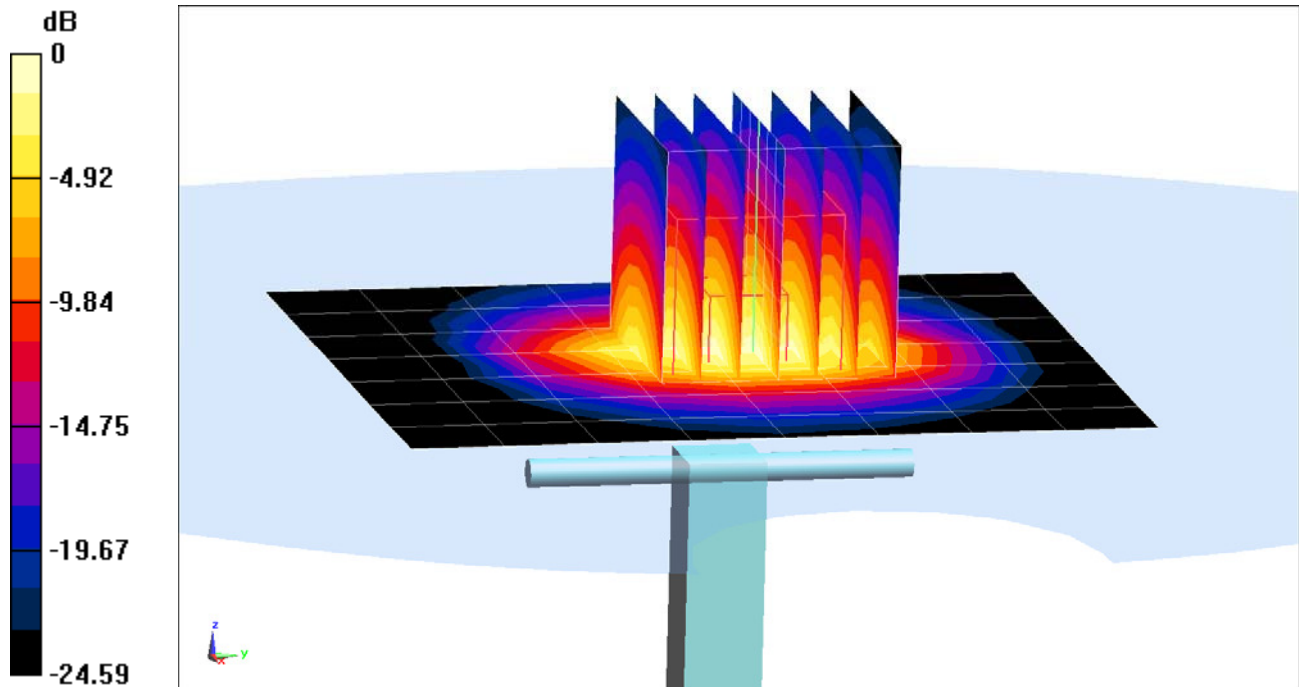

0 dB = 10.1 W/kg = 10.04 dBW/kg

PCTEST ENGINEERING LABORATORY, INC.

DUT: Dipole 5 GHz; Type: D5GHzV2; Serial: 1237

Communication System: UID 0, CW; Frequency: 5250 MHz; Duty Cycle: 1:1
Medium: 5 GHz Body Medium parameters used (interpolated):
 $f = 5250 \text{ MHz}$; $\sigma = 5.502 \text{ S/m}$; $\epsilon_r = 47.905$; $\rho = 1000 \text{ kg/m}^3$
Phantom section: Flat Section; Space: 1.0 cm

Test Date: 01-22-2017; Ambient Temp: 21.9°C; Tissue Temp: 21.4°C

Probe: EX3DV4 - SN3914; ConvF(4.32, 4.32, 4.32); Calibrated: 2/22/2016;
Sensor-Surface: 1.4mm (Mechanical Surface Detection)
Electronics: DAE4 Sn1272; Calibrated: 2/18/2016

Phantom: SAM with CRP v5.0 Front; Type: QD000P40CD; Serial: 1646
Measurement SW: DASY52, Version 52.8 (8); SEMCAD X Version 14.6.10 (7331)

5250 MHz System Verification at 17.0 dBm (50 mW)

Area Scan (7x7x1): Measurement grid: dx=10mm, dy=10mm

Zoom Scan (8x8x7)/Cube 0: Measurement grid: dx=4mm, dy=4mm, dz=1.4mm; Graded Ratio: 1.4

Peak SAR (extrapolated) = 14.3 W/kg

SAR(1 g) = 3.49 W/kg

Deviation(1 g) = -6.68%

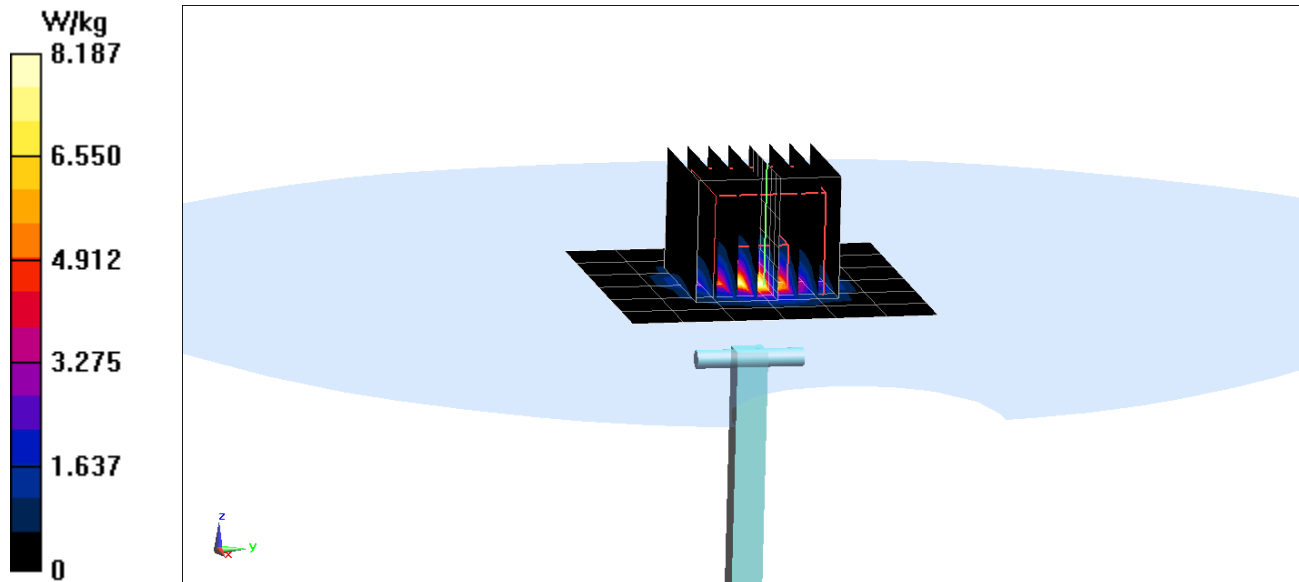

PCTEST ENGINEERING LABORATORY, INC.

DUT: Dipole 5 GHz; Type: D5GHzV2; Serial: 1237

Communication System: UID 0, CW; Frequency: 5600 MHz; Duty Cycle: 1:1

Medium: 5 GHz Body Medium parameters used:

$f = 5600 \text{ MHz}$; $\sigma = 5.972 \text{ S/m}$; $\epsilon_r = 47.325$; $\rho = 1000 \text{ kg/m}^3$

Phantom section: Flat Section; Space: 1.0 cm

Test Date: 01-22-2017; Ambient Temp: 21.9°C; Tissue Temp: 21.4°C

Probe: EX3DV4 - SN3914; ConvF(3.63, 3.63, 3.63); Calibrated: 2/22/2016;

Sensor-Surface: 1.4mm (Mechanical Surface Detection)

Electronics: DAE4 Sn1272; Calibrated: 2/18/2016

Phantom: SAM with CRP v5.0 Front; Type: QD000P40CD; Serial: 1646

Measurement SW: DASY52, Version 52.8 (8); SEMCAD X Version 14.6.10 (7331)

5600 MHz System Verification at 17.0 dBm (50 mW)

Area Scan (7x7x1): Measurement grid: dx=10mm, dy=10mm

Zoom Scan (8x8x7)/Cube 0: Measurement grid: dx=4mm, dy=4mm, dz=1.4mm; Graded Ratio: 1.4

Peak SAR (extrapolated) = 16.3 W/kg

SAR(1 g) = 3.95 W/kg

Deviation(1 g) = 2.60%

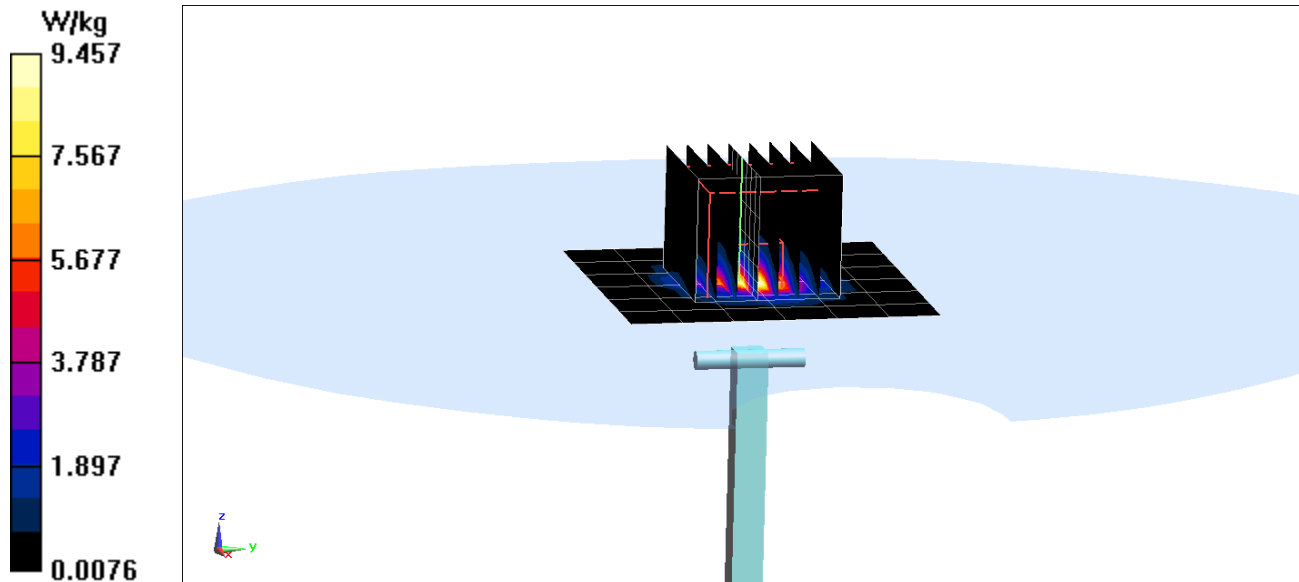

PCTEST ENGINEERING LABORATORY, INC.

DUT: Dipole 5 GHz; Type: D5GHzV2; Serial: 1237

Communication System: UID 0, CW; Frequency: 5750 MHz; Duty Cycle: 1:1
Medium: 5 GHz Body Medium parameters used (interpolated):
 $f = 5750 \text{ MHz}$; $\sigma = 6.178 \text{ S/m}$; $\epsilon_r = 47.043$; $\rho = 1000 \text{ kg/m}^3$
Phantom section: Flat Section; Space: 1.0 cm

Test Date: 01-22-2017; Ambient Temp: 21.9°C; Tissue Temp: 21.4°C

Probe: EX3DV4 - SN3914; ConvF(3.86, 3.86, 3.86); Calibrated: 2/22/2016;
Sensor-Surface: 1.4mm (Mechanical Surface Detection)
Electronics: DAE4 Sn1272; Calibrated: 2/18/2016
Phantom: SAM with CRP v5.0 Front; Type: QD000P40CD; Serial: 1646
Measurement SW: DASY52, Version 52.8 (8); SEMCAD X Version 14.6.10 (7331)

5750 MHz System Verification at 17.0 dBm (50 mW)

Area Scan (7x7x1): Measurement grid: dx=10mm, dy=10mm

Zoom Scan (8x8x7)/Cube 0: Measurement grid: dx=4mm, dy=4mm, dz=1.4mm; Graded Ratio: 1.4

Peak SAR (extrapolated) = 14.8 W/kg

SAR(1 g) = 3.43 W/kg

Deviation(1 g) = -9.02%

