

FCC LTE REPORT

FCC Certification

Applicant Name: LG Electronics MobileComm U.S.A., Inc.	Date of Issue: October 14, 2015
Address: 1000 Sylvan Avenue, Englewood Cliffs NJ 07632	Location: HCT CO., LTD., 74, Seoicheon-ro 578beon-gil, Majang-myeon, Icheon-si, Gyeonggi-do, 17383, Rep. of KOREA
	Report No.: HCT-R-1510-F005
	HCT FRN: 0005866421

FCC ID: ZNFH815PX

APPLICANT: LG Electronics MobileComm U.S.A., Inc.

FCC Model(s): LG-H815PX
Additional FCC Model(s): LGH815PX, H815PX, LG-H815Px, LGH815Px, H815Px, LG-H815pX, LGH815pX, H815pX, LG-H815px, LGH815px, H815px

EUT Type: Cellular/PCS GSM/GPRS/EDGE/WCDMA/HSDPA/HSUPA/LTE Phone with Bluetooth, WLAN, NFC

FCC Classification: Licensed Portable Transmitter Held to Ear (PCE)

FCC Rule Part(s): §2 , §22, §24

Standalone with normal cover

Mode (MHz)	Tx Frequency (MHz)	Emission Designator	Modulation	EIRP	
				Max. Power (W)	Max. Power (dBm)
LTE – Band2 (1.4)	1850.7 - 1909.3	1M09G7D	QPSK	0.203	23.07
		1M09W7D	16QAM	0.145	21.63
LTE – Band2 (3)	1851.5 - 1908.5	2M70G7D	QPSK	0.189	22.76
		2M70W7D	16QAM	0.147	21.68
LTE – Band2 (5)	1852.5 - 1907.5	4M49G7D	QPSK	0.192	22.84
		4M50W7D	16QAM	0.146	21.65
LTE – Band2 (10)	1855.0 - 1905.0	8M98G7D	QPSK	0.200	23.01
		8M96W7D	16QAM	0.154	21.88
LTE – Band2 (15)	1857.5 - 1902.5	13M5G7D	QPSK	0.220	23.43
		13M5W7D	16QAM	0.163	22.13
LTE – Band2 (20)	1860.0 - 1900.0	18M0G7D	QPSK	0.219	23.41
		18M0W7D	16QAM	0.173	22.38

Mode (MHz)	Tx Frequency (MHz)	Emission Designator	Modulation	ERP	
				Max. Power (W)	Max. Power (dBm)
LTE – Band5 (1.4)	824.7 – 848.3	1M09G7D	QPSK	0.064	18.04
		1M10W7D	16QAM	0.046	16.59
LTE – Band5 (3)	825.5 – 847.5	2M71G7D	QPSK	0.063	17.96
		2M70W7D	16QAM	0.047	16.73
LTE – Band5 (5)	826.5 – 846.5	4M51G7D	QPSK	0.065	18.11
		4M51W7D	16QAM	0.047	16.73
LTE – Band5 (10)	829.0 – 844.0	8M99G7D	QPSK	0.060	17.75
		8M95W7D	16QAM	0.044	16.46

Standalone with wireless charging cover (close)

Mode (MHz)	Tx Frequency (MHz)	Modulation	EIRP	
			Max. Power (W)	Max. Power (dBm)
LTE – Band2 (1.4)	1850.7 - 1909.3	QPSK	0.235	23.72
		16QAM	0.174	22.41
LTE – Band2 (3)	1851.5 - 1908.5	QPSK	0.224	23.50
		16QAM	0.174	22.41
LTE – Band2 (5)	1852.5 - 1907.5	QPSK	0.228	23.58
		16QAM	0.173	22.38
LTE – Band2 (10)	1855.0 - 1905.0	QPSK	0.236	23.74
		16QAM	0.179	22.54
LTE – Band2 (15)	1857.5 - 1902.5	QPSK	0.268	24.28
		16QAM	0.198	22.97
LTE – Band2 (20)	1860.0 - 1900.0	QPSK	0.261	24.17
		16QAM	0.208	23.18

Mode (MHz)	Tx Frequency (MHz)	Modulation	ERP	
			Max. Power (W)	Max. Power (dBm)
LTE – Band5 (1.4)	824.7 – 848.3	QPSK	0.067	18.25
		16QAM	0.049	16.92
LTE – Band5 (3)	825.5 – 847.5	QPSK	0.055	17.44
		16QAM	0.042	16.21
LTE – Band5 (5)	826.5 – 846.5	QPSK	0.058	17.66
		16QAM	0.043	16.35
LTE – Band5 (10)	829.0 – 844.0	QPSK	0.057	17.55
		16QAM	0.041	16.12

With wireless charging pad

Mode (MHz)	Tx Frequency (MHz)	Modulation	EIRP	
			Max. Power (W)	Max. Power (dBm)
LTE – Band2 (1.4)	1850.7 - 1909.3	QPSK	0.125	20.98
		16QAM	0.090	19.55
LTE – Band2 (3)	1851.5 - 1908.5	QPSK	0.117	20.69
		16QAM	0.093	19.67
LTE – Band2 (5)	1852.5 - 1907.5	QPSK	0.119	20.77
		16QAM	0.091	19.59
LTE – Band2 (10)	1855.0 - 1905.0	QPSK	0.123	20.91
		16QAM	0.094	19.72
LTE – Band2 (15)	1857.5 - 1902.5	QPSK	0.136	21.33
		16QAM	0.102	20.10
LTE – Band2 (20)	1860.0 - 1900.0	QPSK	0.137	21.37
		16QAM	0.108	20.34

Mode (MHz)	Tx Frequency (MHz)	Modulation	ERP	
			Max. Power (W)	Max. Power (dBm)
LTE – Band5 (1.4)	824.7 – 848.3	QPSK	0.057	17.59
		16QAM	0.042	16.20
LTE – Band5 (3)	825.5 – 847.5	QPSK	0.059	17.69
		16QAM	0.041	16.17
LTE – Band5 (5)	826.5 – 846.5	QPSK	0.060	17.77
		16QAM	0.042	16.26
LTE – Band5 (10)	829.0 – 844.0	QPSK	0.057	17.54
		16QAM	0.043	16.36

The measurements shown in this report were made in accordance with the procedures specified in CFR47 section §2.947. I assume full responsibility for the accuracy and completeness of these measurements, and for the qualifications of all persons taking them.

HCT CO., LTD. Certifies that no party to this application has subject to a denial of Federal benefits that includes FCC benefits pursuant to section 5301 of the Anti-Drug Abuse Act of 1998,21 U.S. C.853(a)



Report prepared by
: Jeong Ho Kim
Test engineer of RF Team



Approved by
: Yong Hyun Lee
Manager of RF Team

This report only responds to the tested sample and may not be reproduced, except in full, without written approval of the HCT Co., Ltd.

Version

TEST REPORT NO.	DATE	DESCRIPTION
HCT-R-1510-F005	October 14, 2015	- First Approval Report

Table of Contents

1. GENERAL INFORMATION	7
2. INTRODUCTION	10
2.1. EUT DESCRIPTION.....	10
2.2. MEASURING INSTRUMENT CALIBRATION.....	10
2.3. TEST FACILITY	10
3. DESCRIPTION OF TESTS	11
3.1 ERP/EIRP RADIATED POWER AND RADIATED SPURIOUS EMISSIONS.....	11
3.2 FREQUENCY RANGE.....	12
3.3 PEAK-AVERAGE RATIO.	13
3.4 OCCUPIED BANDWIDTH.	15
3.5 SPURIOUS AND HARMONIC EMISSIONS AT ANTENNA TERMINAL.....	16
3.6 FREQUENCY STABILITY / VARIATION OF AMBIENT TEMPERATURE	17
4. LIST OF TEST EQUIPMENT	18
5. SUMMARY OF TEST RESULTS	19
6. SAMPLE CALCULATION.....	20
7. TEST DATA	21
7.1 EQUIVALENT ISOTROPIC RADIATED POWER (Band 2) _ Standalone with normal cover	21
7.2 EFFECTIVE RADIATED POWER (Band 5) _ Standalone with normal cover	25
7.3 EQUIVALENT ISOTROPIC RADIATED POWER (Band 2) _ Standalone with wireless charging cover (close)	28
7.4 EFFECTIVE RADIATED POWER (Band 5) _ Standalone with wireless charging cover (close)	32
7.5 EQUIVALENT ISOTROPIC RADIATED POWER (Band 2) _ With wireless charging pad.....	35
7.6 EFFECTIVE RADIATED POWER (Band 5) _ With wireless charging pad.....	39
7.7 RADIATED SPURIOUS EMISSIONS _ Standalone with normal cover	42
7.7.1 RADIATED SPURIOUS EMISSIONS (1.4 MHz Band 2 LTE).....	42
7.7.2 RADIATED SPURIOUS EMISSIONS (3 MHz Band 2 LTE).....	43
7.7.3 RADIATED SPURIOUS EMISSIONS (5 MHz Band 2 LTE).....	44
7.7.4 RADIATED SPURIOUS EMISSIONS (10 MHz Band 2 LTE).....	45
7.7.5 RADIATED SPURIOUS EMISSIONS (15 MHz Band 2 LTE).....	46
7.7.6 RADIATED SPURIOUS EMISSIONS (20 MHz Band 2 LTE).....	47
7.7.7 RADIATED SPURIOUS EMISSIONS (1.4 MHz Band 5 LTE).....	48
7.7.8 RADIATED SPURIOUS EMISSIONS (3 MHz Band 5 LTE).....	49
7.7.9 RADIATED SPURIOUS EMISSIONS (5 MHz Band 5 LTE).....	50
7.7.10 RADIATED SPURIOUS EMISSIONS (10 MHz Band 5 LTE).....	51
7.8 RADIATED SPURIOUS EMISSIONS _ Standalone with wireless charging cover (close)	52
7.8.1 RADIATED SPURIOUS EMISSIONS (1.4 MHz Band 2 LTE).....	52
7.8.2 RADIATED SPURIOUS EMISSIONS (3 MHz Band 2 LTE).....	53
7.8.3 RADIATED SPURIOUS EMISSIONS (5 MHz Band 2 LTE).....	54
7.8.4 RADIATED SPURIOUS EMISSIONS (10 MHz Band 2 LTE).....	55
7.8.5 RADIATED SPURIOUS EMISSIONS (15 MHz Band 2 LTE).....	56
7.8.6 RADIATED SPURIOUS EMISSIONS (20 MHz Band 2 LTE).....	57

7.8.7 RADIATED SPURIOUS EMISSIONS (1.4 MHz Band 5 LTE).....	58
7.8.8 RADIATED SPURIOUS EMISSIONS (3 MHz Band 5 LTE).....	59
7.8.9 RADIATED SPURIOUS EMISSIONS (5 MHz Band 5 LTE).....	60
7.8.10 RADIATED SPURIOUS EMISSIONS (10 MHz Band 5 LTE).....	61
7.9 RADIATED SPURIOUS EMISSIONS _ With wireless charging pad	62
7.9.1 RADIATED SPURIOUS EMISSIONS (1.4 MHz Band 2 LTE).....	62
7.9.2 RADIATED SPURIOUS EMISSIONS (3 MHz Band 2 LTE).....	63
7.9.3 RADIATED SPURIOUS EMISSIONS (5 MHz Band 2 LTE).....	64
7.9.4 RADIATED SPURIOUS EMISSIONS (10 MHz Band 2 LTE).....	65
7.9.5 RADIATED SPURIOUS EMISSIONS (15 MHz Band 2 LTE).....	66
7.9.6 RADIATED SPURIOUS EMISSIONS (20 MHz Band 2 LTE).....	67
7.9.7 RADIATED SPURIOUS EMISSIONS (1.4 MHz Band 5 LTE).....	68
7.9.8 RADIATED SPURIOUS EMISSIONS (3 MHz Band 5 LTE).....	69
7.9.9 RADIATED SPURIOUS EMISSIONS (5 MHz Band 5 LTE).....	70
7.9.10 RADIATED SPURIOUS EMISSIONS (10 MHz Band 5 LTE).....	71
7.10 PEAK-TO-AVERAGE RATIO	72
7.11 OCCUPIED BANDWIDTH	73
7.12 CONDUCTED SPURIOUS EMISSIONS	74
7.12.1 BAND EDGE.....	75
7.13 FREQUENCY STABILITY / VARIATION OF AMBIENT TEMPERATURE	76
7.13.1 FREQUENCY STABILITY (1.4 MHz Band 2 LTE).....	76
7.13.2 FREQUENCY STABILITY (3 MHz Band 2 LTE).....	77
7.13.3 FREQUENCY STABILITY (5 MHz Band 2 LTE).....	78
7.13.4 FREQUENCY STABILITY (10 MHz Band 2 LTE).....	79
7.13.5 FREQUENCY STABILITY (15 MHz Band 2 LTE).....	80
7.13.6 FREQUENCY STABILITY (20 MHz Band 2 LTE).....	81
7.13.7 FREQUENCY STABILITY (1.4 MHz Band 5 LTE).....	82
7.13.8 FREQUENCY STABILITY (3 MHz Band 5 LTE).....	83
7.13.9 FREQUENCY STABILITY (5 MHz Band 5 LTE).....	84
7.13.10 FREQUENCY STABILITY (10 MHz Band 5 LTE).....	85
8. TEST PLOTS.....	86

MEASUREMENT REPORT

1. GENERAL INFORMATION

Applicant Name: LG Electronics MobileComm U.S.A., Inc.
Address: 1000 Sylvan Avenue, Englewood Cliffs NJ 07632
FCC ID: ZNFH815PX
Application Type: Certification
FCC Classification: Licensed Portable Transmitter Held to Ear (PCE)
FCC Rule Part(s): §2 , §22, §24
EUT Type: Cellular/PCS GSM/GPRS/EDGE/WCDMA/HSDPA/HSUPA/LTE Phone with Bluetooth, WLAN, NFC
FCC Model(s): LG-H815PX
Additional FCC Model(s): LGH815PX, H815PX, LG-H815Px, LGH815Px, H815Px, LG-H815pX, LGH815pX, H815pX, LG-H815px, LGH815px, H815px

Tx Frequency: 1850.7 MHz – 1909.3 MHz (LTE – Band2 (1.4 MHz))
1851.5 MHz – 1908.5 MHz (LTE – Band2 (3 MHz))
1852.5 MHz – 1907.5 MHz (LTE – Band2 (5 MHz))
1855.0 MHz – 1905.0 MHz (LTE – Band2 (10 MHz))
1857.5 MHz – 1902.5 MHz (LTE – Band2 (15 MHz))
1860.0 MHz – 1900.0 MHz (LTE – Band2 (20 MHz))

824.7 MHz – 848.3 MHz (LTE – Band 5 (1.4 MHz))
825.5 MHz – 847.5 MHz (LTE – Band 5 (3 MHz))
826.5 MHz – 846.5 MHz (LTE – Band 5 (5 MHz))
829.0 MHz – 844.0 MHz (LTE – Band 5 (10 MHz))

Max. RF Output Power:

Standalone with normal cover:

Band 2 (1.4 MHz) :	0.203 W (QPSK) (23.07 dBm) 0.145 W (16-QAM) (21.63 dBm)
Band 2 (3 MHz) :	0.189 W (QPSK) (22.76 dBm) 0.147 W (16-QAM) (21.68 dBm)
Band 2 (5 MHz) :	0.192 W (QPSK) (22.84 dBm) 0.146 W (16-QAM) (21.65 dBm)
Band 2 (10 MHz) :	0.200 W (QPSK) (23.01 dBm) 0.154 W (16-QAM) (21.88 dBm)
Band 2 (15 MHz) :	0.220 W (QPSK) (23.43 dBm) 0.163 W (16-QAM) (22.13 dBm)
Band 2 (20 MHz) :	0.219 W (QPSK) (23.41 dBm) 0.173 W (16-QAM) (22.38 dBm)
Band 5 (1.4 MHz) :	0.064 W (QPSK) (18.04 dBm) 0.046 W (16-QAM) (16.59 dBm)
Band 5 (3 MHz) :	0.063 W (QPSK) (17.96 dBm) 0.047 W (16-QAM) (16.73 dBm)
Band 5 (5 MHz) :	0.065 W (QPSK) (18.11 dBm) 0.047 W (16-QAM) (16.73 dBm)
Band 5 (10 MHz) :	0.060 W (QPSK) (17.75 dBm) 0.044 W (16-QAM) (16.46 dBm)

Standalone with wireless charging cover (close) :

Band 2 (1.4 MHz) :	0.235 W (QPSK) (23.72 dBm)
	0.174 W (16-QAM) (22.41 dBm)
Band 2 (3 MHz) :	0.224 W (QPSK) (23.50 dBm)
	0.174 W (16-QAM) (22.41 dBm)
Band 2 (5 MHz) :	0.228 W (QPSK) (23.58 dBm)
	0.173 W (16-QAM) (22.38 dBm)
Band 2 (10 MHz) :	0.236 W (QPSK) (23.74 dBm)
	0.179 W (16-QAM) (22.54 dBm)
Band 2 (15 MHz) :	0.268 W (QPSK) (24.28 dBm)
	0.198 W (16-QAM) (22.97 dBm)
Band 2 (20 MHz) :	0.261 W (QPSK) (24.17 dBm)
	0.208 W (16-QAM) (23.18 dBm)

Band 5 (1.4 MHz) :	0.067 W (QPSK) (18.25 dBm)
	0.049 W (16-QAM) (16.92 dBm)
Band 5 (3 MHz) :	0.055 W (QPSK) (17.44 dBm)
	0.042 W (16-QAM) (16.21 dBm)
Band 5 (5 MHz) :	0.058 W (QPSK) (17.66 dBm)
	0.043 W (16-QAM) (16.35 dBm)
Band 5 (10 MHz) :	0.057 W (QPSK) (17.55 dBm)
	0.041 W (16-QAM) (16.12 dBm)

With wireless charging pad :

Band 2 (1.4 MHz) :	0.125 W (QPSK) (20.98 dBm)
	0.090 W (16-QAM) (19.55 dBm)
Band 2 (3 MHz) :	0.117 W (QPSK) (20.69 dBm)
	0.093 W (16-QAM) (19.67 dBm)
Band 2 (5 MHz) :	0.119 W (QPSK) (20.77 dBm)
	0.091 W (16-QAM) (19.59 dBm)
Band 2 (10 MHz) :	0.123 W (QPSK) (20.91 dBm)
	0.094 W (16-QAM) (19.72 dBm)
Band 2 (15 MHz) :	0.136 W (QPSK) (21.33 dBm)
	0.102 W (16-QAM) (20.10 dBm)
Band 2 (20 MHz) :	0.137 W (QPSK) (21.37 dBm)
	0.108 W (16-QAM) (20.34 dBm)

Band 5 (1.4 MHz) :	0.057 W (QPSK) (17.59 dBm)
	0.042 W (16-QAM) (16.20 dBm)
Band 5 (3 MHz) :	0.059 W (QPSK) (17.69 dBm)
	0.041 W (16-QAM) (16.17 dBm)
Band 5 (5 MHz) :	0.060 W (QPSK) (17.77 dBm)
	0.042 W (16-QAM) (16.26 dBm)
Band 5 (10 MHz) :	0.057 W (QPSK) (17.54 dBm)
	0.043 W (16-QAM) (16.36 dBm)

Emission Designator(s):

Band 2 (1.4 MHz) :	1M09G7D (QPSK) / 1M09W7D (16-QAM)
Band 2 (3 MHz) :	2M70G7D (QPSK) / 2M70W7D (16-QAM)
Band 2 (5 MHz) :	4M49G7D (QPSK) / 4M50W7D (16-QAM)
Band 2 (10 MHz) :	8M98G7D (QPSK) / 8M96W7D (16-QAM)
Band 2 (15 MHz) :	13M5G7D (QPSK) / 13M5W7D (16-QAM)
Band 2 (20 MHz) :	18M0G7D (QPSK) / 18M0W7D (16-QAM)
Band 5 (1.4 MHz) :	1M09G7D (QPSK) / 1M10W7D (16-QAM)
Band 5 (3 MHz) :	2M71G7D (QPSK) / 2M70W7D (16-QAM)
Band 5 (5 MHz) :	4M51G7D (QPSK) / 4M51W7D (16-QAM)
Band 5 (10 MHz) :	8M99G7D (QPSK) / 8M95W7D (16-QAM)

Date(s) of Tests: March 21, 2015 ~ April 14, 2015

Antenna Specification
Manufacturer: Ace Technology
Antenna type: PIFA Antenna (Planar Inverted F)
Peak Gain: Band 2: -3.33 dBi
Peak Gain: Band 5: -2.58 dBi

Note: The device, LG-H815PX (FCC ID: ZNFH815PX) is electrically identical compare to LG-H815 (FCC ID: ZNFH815), and There is no Hardware Change. Simply enable software to WCDMA Band4. So, we reuse the test data of model LG-H815 (FCC ID: ZNFH815). But WCDMA B4 was Test.

2. INTRODUCTION

2.1. EUT DESCRIPTION

The LG Electronics MobileComm U.S.A., Inc. LG-H815PX Cellular/PCS GSM/GPRS/EDGE/WCDMA/HSDPA/HSUPA/LTE Phone with Bluetooth, WLAN, NFC consists of LTE 2 and 5.

2.2. MEASURING INSTRUMENT CALIBRATION

The measuring equipment, which was utilized in performing the tests documented herein, has been calibrated in accordance with the manufacturer's recommendations for utilizing calibration equipment, which is traceable to recognized national standards.

2.3. TEST FACILITY

The Fully-anechoic chamber and conducted measurement facility used to collect the radiated data are located at the **74, Seoicheon-ro 578beon-gil, Majang-myeon, Icheon-si, Gyeonggi-do, 17383, Rep. of KOREA.**

3. DESCRIPTION OF TESTS

3.1 ERP/EIRP RADIATED POWER AND RADIATED SPURIOUS EMISSIONS

Note: ERP(Effective Radiated Power), EIRP(Effective Isotropic Radiated Power)

Test Procedure

Radiated emission measurements are performed in the Fully-anechoic chamber. The equipment under test is placed on a non-conductive table 3-meters away from the receive antenna in accordance with ANSI/TIA-603-D-2010 Clause 2.2.17. The turntable is rotated through 360 degrees, and the receiving antenna scans in order to determine the level of the maximized emission. The level and position of the maximized emission is recorded with the spectrum analyzer using a RMS detector.

A half wave dipole is then substituted in place of the EUT. For emissions above 1GHz, a horn antenna is substituted in place of the EUT. The substitute antenna is driven by a signal generator and the previously recorded signal was duplicated.

The power is calculated by the following formula;

$$P_{d(\text{dBm})} = P_{g(\text{dBm})} - \text{cable loss}_{(\text{dB})} + \text{antenna gain}_{(\text{dB})}$$

Where: P_d is the dipole equivalent power and P_g is the generator output power into the substitution antenna.

The maximum EIRP is calculated by adding the forward power to the calibrated source plus its appropriate gain value. These steps are repeated with the receiving antenna in both vertical and horizontal polarization. the difference between the gain of the horn and an isotropic antenna are taken into consideration

Radiated spurious emissions

: Frequency Range : 30 MHz ~ 10th Harmonics of highest channel fundamental frequency.

3.2 FREQUENCY RANGE

§22.917(a): Cellular – Mobile Frequency Blocks

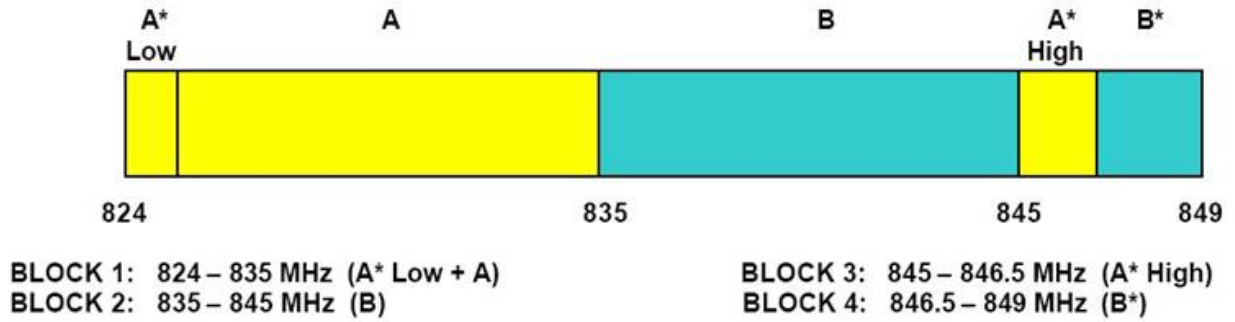

§ 24.229: PCS – Mobile Frequency Blocks

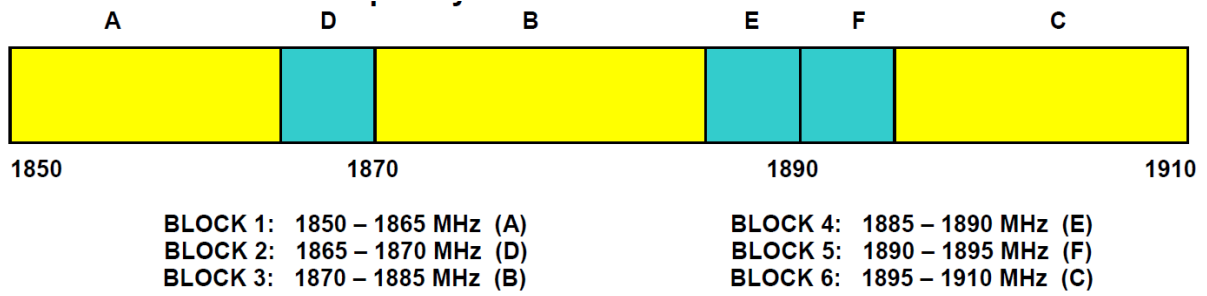

3.3 PEAK-AVERAGE RATIO.

Test Procedure

Peak to Average Power Ratio is tested in accordance with KDB971168 D01 Power Meas License Digital Systems v02r02, October 17, 2014, Section 5.7.

- Section 5.7.1 CCDF Procedure

- a) Set resolution/measurement bandwidth \geq signal's occupied bandwidth;
- b) Set the number of counts to a value that stabilizes the measured CCDF curve;
- c) Set the measurement interval as follows:
 - 1) for continuous transmissions, set to 1 ms,
 - 2) for burst transmissions, employ an external trigger that is synchronized with the EUT burst timing sequence, or use the internal burst trigger with a trigger level that allows the burst to stabilize and set the measurement interval to a time that is less than or equal to the burst duration.
- d) Record the maximum PAPR level associated with a probability of 0.1%.

- Section 5.7.2 Alternate Procedure

Use one of the procedures presented in 5.1 to measure the total peak power and record as P_{Pk} . Use one of the applicable procedures presented 5.2 to measure the total average power and record as P_{Avg} . Determine the P.A.R. from: $P.A.R_{(dB)} = P_{Pk (dBm)} - P_{Avg (dBm)}$ (P_{Avg} = Average Power + Duty cycle Factor)

5.1.1 Peak power measurements with a spectrum/signal analyzer or EMI receiver

The following procedure can be used to determine the total peak output power.

- a) Set the RBW \geq OBW.
- b) Set VBW $\geq 3 \times$ RBW.
- c) Set span $\geq 2 \times$ RBW
- d) Sweep time = auto couple.
- e) Detector = peak.
- f) Ensure that the number of measurement points \geq span/RBW.
- g) Trace mode = max hold.
- h) Allow trace to fully stabilize.
- i) Use the peak marker function to determine the peak amplitude level.

5.2.2 Procedures for use with a spectrum/signal analyzer when EUT cannot be configured to transmit continuously and sweep triggering/signal gating cannot be properly implemented

If the EUT cannot be configured to transmit continuously (burst duty cycle < 98%), then one of the following procedures can be used. The selection of the applicable procedure will depend on the characteristics of the measured burst duty cycle.

Measure the burst duty cycle with a spectrum/signal analyzer or EMC receiver can be used in zero-span mode if the response time and spacing between bins on the sweep are sufficient to permit accurate measurement of the burst on/off time of the transmitted signal.

5.2.2.2 Constant burst duty cycle

If the measured burst duty cycle is constant (i.e., duty cycle variations are less than ± 2 percent), then:

- a) Set span to at least 1.5 times the OBW.
- b) Set RBW = 1-5% of the OBW, not to exceed 1 MHz.
- c) Set VBW $\geq 3 \times$ RBW.
- d) Number of points in sweep $\geq 2 \times$ span / RBW. (This gives bin-to-bin spacing \leq RBW/2, so that narrowband signals are not lost between frequency bins.)
- e) Sweep time = auto.
- f) Detector = RMS (power averaging).
- g) Set sweep trigger to "free run".
- h) Trace average at least 100 traces in power averaging (i.e., RMS) mode.
- i) Compute power by integrating the spectrum across the OBW of the signal using the instrument's band power measurement function with band limits set equal to the OBW band edges. If the instrument does not have a band power function, sum the spectrum levels (in power units) at intervals equal to the RBW extending across the entire OBW of the spectrum.
- j) Add $10 \log (1/x)$, where x is the duty cycle, to the measured power in order to compute the average power during the actual transmission times (because the measurement represents an average over both the on and off times of the transmission).

For example, add $10 \log (1/0.25) = 6$ dB if the duty cycle is a constant 25%.

3.4 OCCUPIED BANDWIDTH.

Test set-up

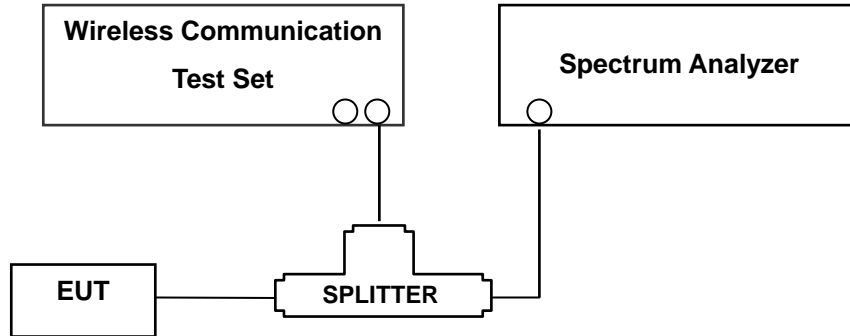

(Configuration of conducted Emission measurement)

The width of a frequency band such that, below the lower and above the upper frequency limits, the mean powers emitted are each equal to a specified percentage 0.5 % of the total mean power of a given emission.

Test Procedure

OBW is tested in accordance with KDB971168 D01 Power Meas License Digital Systems v02r02, October 17, 2014, Section 4.2.

The EUT makes a call to the communication simulator. The power was measured with R&S Spectrum Analyzer. All measurements were done at 3 channels(low, middle and high operational range.)

The conducted occupied bandwidth used the power splitter via EUT RF power connector between simulation base station and spectrum analyzer.

The communication simulator station system controlled a EUT to export maximum output power under transmission mode and specific channel frequency. Use OBW measurement function of Spectrum analyzer to measure 99 % occupied bandwidth

3.5 SPURIOUS AND HARMONIC EMISSIONS AT ANTENNA TERMINAL.

Test Procedure

Spurious and harmonic emissions at antenna terminal is tested in accordance with KDB971168 D01 Power Meas License Digital Systems v02r02, October 17, 2014, Section 6.0.

The level of the carrier and the various conducted spurious and harmonic frequencies is measured by means of a calibrated spectrum analyzer.

The EUT was setup to maximum output power at its lowest channel. The Resolution BW of the analyzer is set to 1 % of the emission bandwidth to show compliance with the -13 dBm limit, in the 1 MHz bands immediately outside and adjacent to the edge of the frequency block. The 1 MHz RBW was used to scan from 30 MHz to 10th Harmonics. A display line was placed at -13 dBm to show compliance. The high, lowest and a middle channel were tested for out of band measurements.

- Band Edge Requirement : In the 1MHz bands immediately outside and adjacent to the frequency block, a resolution bandwidth of at least 1 percent of the emission bandwidth of the fundamental emission of the transmitter may be employed to measure the out of band Emissions. Limit, -13 dBm.

NOTES: The analyzer plot offsets were determined by below conditions.

- For LTE Band 2, total offset 27.4 dBm = 20 dBm attenuator + 6 dBm Divider + 1.4 dBm RF cables.
- For LTE Band 5, total offset 26.8 dB = 20 dB attenuator + 6 dB Divider + 0.8 dB RF cables.

3.6 FREQUENCY STABILITY / VARIATION OF AMBIENT TEMPERATURE

Test Set-up

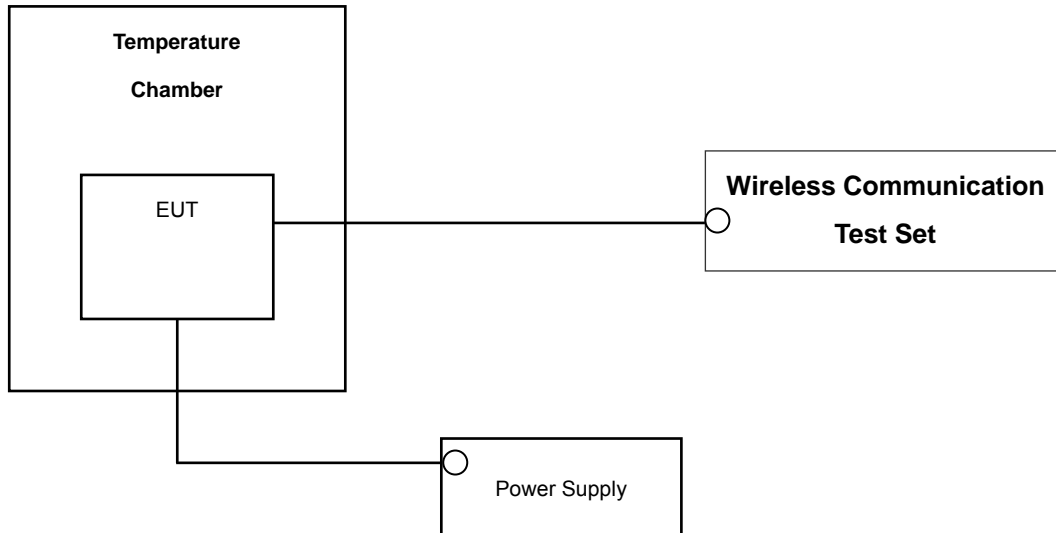

* Nominal Operating Voltage

Test Procedure

Frequency stability is tested in accordance with ANSI/TIA-603-D-2010 section 2.2.2

The frequency stability of the transmitter is measured by:

- a.) **Temperature:** The temperature is varied from - 30 °C to + 50 °C using an environmental chamber.
- b.) **Primary Supply Voltage:** The primary supply voltage is varied from the end point to 100 % of the voltage normally at the input to the device or at the power supply terminals if cables are not normally supplied.

Specification — the frequency stability shall be sufficient to ensure that the fundamental emission stays within the authorized frequency block (LTE Band2). The frequency stability of the transmitter shall be maintained within ± 0.00025 % (± 2.5 ppm) of the center frequency. (LTE Band5).

Time Period and Procedure:

The carrier frequency of the transmitter is measured at room temperature (20°C to provide a reference).

1. The equipment is turned on in a “standby” condition for one minute before applying power to the transmitter. Measurement of the carrier frequency of the transmitter is made within one minute after applying power to the transmitter.
2. Frequency measurements are made at 10°C intervals ranging from -30°C to +50°C. A period of at least one half-hour is provided to allow stabilization of the equipment at each temperature level.

NOTE: The EUT is tested down to the battery endpoint.

4. LIST OF TEST EQUIPMENT

Manufacture	Model/ Equipment	Serial Number	Calibration Interval	Calibration Due
LG innotek CHINA	WCD-110/WCP	LF1NA625283010191(1.1)		
Agilent	N1921A/ Power Sensor	MY45241059	Annual	07/09/2016
Agilent	N1911A/ Power Meter	MY45100523	Annual	07/09/2016
MITEQ	AMF-6D-001180-35-20P/AMP	1081666	Annual	09/03/2016
Wainwright	WHK1.2/15G-10EF/H.P.F	4	Annual	04/27/2016
Wainwright	WHK3.3/18G-10EF/H.P.F	2	Annual	04/27/2016
Hewlett Packard	11667B / Power Splitter	10545	Annual	02/16/2016
Hewlett Packard	11667B / Power Splitter	11275	Annual	04/29/2016
ITECT	IT6720/ Power Supply	010002156267001199	Annual	11/04/2015
Schwarzbeck	UHAP/ Dipole Antenna	557	Biennial	03/23/2017
Schwarzbeck	UHAP/ Dipole Antenna	558	Biennial	03/23/2017
EXP	EX-TH400/ Chamber	None	Annual	05/29/2016
Schwarzbeck	BBHA 9120D/ Horn Antenna	147	Biennial	09/01/2016
Schwarzbeck	BBHA 9120D/ Horn Antenna	1299	Biennial	05/15/2017
Schwarzbeck	BBHA 9170/ Horn Antenna(15~40GHz)	BBHA9170342	Biennial	04/30/2017
Schwarzbeck	BBHA 9170/ Horn Antenna(15~35GHz)	BBHA9170124	Biennial	04/30/2017
Agilent	N9020A/ Signal Analyzer	MY47380318	Annual	09/07/2016
WEINSCHTEL	ATTENUATOR	BR0592	Annual	10/22/2015
REOHDE&SCHWARZ	FSV40/Spectrum Analyzer	1307.9002K40-100931-NK	Annual	06/04/2016
Agilent	8960 (E5515C)/ Base Station	MY48360800	Annual	10/30/2015
Anritsu Corp.	MT8820C/Wideband Radio Communication Tester	6200863156	Annual	03/24/2016

5. SUMMARY OF TEST RESULTS

FCC Part Section(s)	Test Description	Test Limit	Test Condition	Test Result
2.1049	Occupied Bandwidth	N/A	CONDUCTED	PASS
2.1051, 22.917(a), 24.238(a)	Band Edge / Spurious and Harmonic Emissions at Antenna Terminal.	< 43 + 10log ₁₀ (P[Watts]) at Band Edge and for all out-of-band emissions		PASS
* 2.1046	Conducted Output Power	N/A		PASS
24.232(d)	Peak- to- Average Ratio	< 13 dB		PASS
2.1055, 22.355	Frequency stability / variation of ambient temperature	< 2.5 ppm (Part22)		PASS
24.235		Emission must remain in band (Part24)		PASS
22.913(a)(2)	Effective Radiated Power (Band 5)	< 7 Watts max. ERP	RADIATED	PASS
24.232(c)	Equivalent Isotropic Radiated Power (Band 2)	< 2 Watts max. EIRP		PASS
2.1053, 22.917(a), 24.238(a)	Radiated Spurious and Harmonic Emissions	< 43 + 10log ₁₀ (P[Watts]) for all out-of band emissions		PASS

*: See SAR Report

6. SAMPLE CALCULATION

A. ERP Sample Calculation

Mode	Ch./ Freq.		Measured Level(dBm)	Substitute LEVEL(dBm)	Ant. Gain (dBd)	C.L	Pol.	ERP	
	channel	Freq.(MHz)						W	dBm
LTE Band5	20525	836.60	-6.73	40.89	-10.54	0.96	V	0.869	29.39

ERP = SubstituteLEVEL(dBm) + Ant. Gain – CL(Cable Loss)

- 1) The EUT mounted on a wooden tripod is 2.5 meter above test site ground level.
- 2) During the test , the turn table is rotated and the antenna height is found.
- 3) Record the field strength meter's level.
- 4) Replace the EUT with dipole/Horn antenna that is connected to a calibrated signal generator.
- 5) Increase the signal generator output till the field strength meter's level is equal to the item (3).
- 6) The signal generator output level with Ant. Gain and cable loss are the rating of effective radiated power (ERP).

B. Emission Designator

QPSK Modulation

5MHz Bandwidth

Emission Designator = 4M48G7D

LTE BW = 4.48 MHz

G = Phase Modulation

7 = Quantized/Digital Info

D = Data transmission; telemetry; telecommand

10MHz Bandwidth

Emission Designator = 8M95G7D

LTE BW = 8.95 MHz

G = Phase Modulation

7 = Quantized/Digital Info

D = Data transmission; telemetry; telecommand

16QAM Modulation

5MHz Bandwidth

Emission Designator = 4M48W7D

LTE BW = 4.48 MHz

W = main carrier modulated in a combination of two or more of the following modes;
amplitude, angle, pulse

7 = Quantized/Digital Info

D = Data transmission; telemetry; telecommand

10MHz Bandwidth

Emission Designator = 8M95W7D

LTE BW = 8.95 MHz

W = main carrier modulated in a combination of two or more of the following modes;
amplitude, angle, pulse

7 = Quantized/Digital Info

D = Data transmission; telemetry; telecommand

7. TEST DATA

7.1 EQUIVALENT ISOTROPIC RADIATED POWER (Band 2) _ Standalone with normal cover

Freq (MHz)	Band Width (MHz)	Modulation	Measured Level (dBm)	Substitute Level (dBm)	Ant. Gain(dBi)	C.L	Pol	EIRP	
								W	dBm
1850.7	1.4	QPSK	-18.30	14.39	10.04	1.36	H	0.203	23.07
		16-QAM	-19.74	12.95	10.04	1.36	H	0.145	21.63
1880.0		QPSK	-19.18	13.78	10.05	1.37	H	0.176	22.46
		16-QAM	-20.65	12.31	10.05	1.37	H	0.126	20.99
1909.3		QPSK	-19.46	13.74	10.06	1.38	H	0.175	22.42
		16-QAM	-20.84	12.36	10.06	1.38	H	0.127	21.04

Equivalent Isotropic Radiated Power Output Data (1.4 MHz Band 2 LTE)

Note: All of RB size has been tested for emissions and EIRP, with the 1RB configuration observed as the worst case

Freq (MHz)	Band Width (MHz)	Modulation	Measured Level (dBm)	Substitute Level (dBm)	Ant. Gain(dBi)	C.L	Pol	EIRP	
								W	dBm
1851.5	3	QPSK	-18.61	14.08	10.04	1.36	H	0.189	22.76
		16-QAM	-19.69	13.00	10.04	1.36	H	0.147	21.68
1880.0		QPSK	-19.49	13.47	10.05	1.37	H	0.164	22.15
		16-QAM	-20.76	12.20	10.05	1.37	H	0.122	20.88
1908.5		QPSK	-19.65	13.52	10.06	1.38	H	0.166	22.20
		16-QAM	-20.91	12.26	10.06	1.38	H	0.124	20.94

Equivalent Isotropic Radiated Power Output Data (3 MHz Band 2 LTE)

Note: All of RB size has been tested for emissions and EIRP, with the 1RB configuration observed as the worst case

Freq (MHz)	Band Width (MHz)	Modulation	Measured Level (dBm)	Substitute Level (dBm)	Ant. Gain(dBi)	C.L	Pol	EIRP	
								W	dBm
1852.5	5	QPSK	-18.53	14.16	10.04	1.36	H	0.192	22.84
		16-QAM	-19.72	12.97	10.04	1.36	H	0.146	21.65
1880.0		QPSK	-19.43	13.53	10.05	1.37	H	0.166	22.21
		16-QAM	-20.75	12.21	10.05	1.37	H	0.123	20.89
1907.5		QPSK	-19.58	13.56	10.06	1.38	H	0.167	22.24
		16-QAM	-20.94	12.20	10.06	1.38	H	0.122	20.88

Equivalent Isotropic Radiated Power Output Data (5 MHz Band 2 LTE)

Note: All of RB size has been tested for emissions and EIRP, with the 1RB configuration observed as the worst case

Freq (MHz)	Band Width (MHz)	Modulation	Measured Level (dBm)	Substitute Level (dBm)	Ant. Gain(dBi)	C.L	Pol	EIRP	
								W	dBm
1855.0	10	QPSK	-18.36	14.33	10.04	1.36	H	0.200	23.01
		16-QAM	-19.49	13.20	10.04	1.36	H	0.154	21.88
1880.0		QPSK	-19.32	13.63	10.05	1.37	H	0.170	22.31
		16-QAM	-20.62	12.33	10.05	1.37	H	0.126	21.01
1905.0		QPSK	-19.61	13.45	10.05	1.38	H	0.163	22.12
		16-QAM	-20.84	12.22	10.05	1.38	H	0.123	20.89

Equivalent Isotropic Radiated Power Output Data (10 MHz Band 2 LTE)

Note: All of RB size has been tested for emissions and EIRP, with the 1RB configuration observed as the worst case

Freq (MHz)	Band Width (MHz)	Modulation	Measured Level (dBm)	Substitute Level (dBm)	Ant. Gain(dBi)	C.L	Pol	EIRP	
								W	dBm
1857.5	15	QPSK	-17.94	14.75	10.04	1.36	H	0.220	23.43
		16-QAM	-19.24	13.45	10.04	1.36	H	0.163	22.13
1880.0		QPSK	-18.80	14.14	10.04	1.36	H	0.191	22.82
		16-QAM	-20.01	12.93	10.04	1.36	H	0.145	21.61
1902.5		QPSK	-19.27	13.78	10.05	1.38	H	0.176	22.45
		16-QAM	-20.31	12.74	10.05	1.38	H	0.138	21.41

Equivalent Isotropic Radiated Power Output Data (15 MHz Band 2 LTE)

Note: All of RB size has been tested for emissions and EIRP, with the 1RB configuration observed as the worst case

Freq (MHz)	Band Width (MHz)	Modulation	Measured Level (dBm)	Substitute Level (dBm)	Ant. Gain(dBi)	C.L	Pol	EIRP	
								W	dBm
1860.0	20	QPSK	-17.96	14.73	10.04	1.36	H	0.219	23.41
		16-QAM	-18.99	13.70	10.04	1.36	H	0.173	22.38
1880.0		QPSK	-18.83	14.10	10.04	1.36	H	0.190	22.78
		16-QAM	-19.70	13.23	10.04	1.36	H	0.155	21.91
1900.0		QPSK	-19.11	13.95	10.05	1.38	H	0.183	22.62
		16-QAM	-20.15	12.91	10.05	1.38	H	0.144	21.58

Equivalent Isotropic Radiated Power Output Data (20 MHz Band 2 LTE)

Note: All of RB size has been tested for emissions and EIRP, with the 1RB configuration observed as the worst case

NOTES:

Equivalent Isotropic Radiated Power Measurements by Substitution Method according to ANSI/TIA/EIA-603-D-2010 June 24, 2010:

The EUT was placed on a non-conductive styrofoam resin table 3-meters from the receive antenna. Turntable rotation was adjusted for the highest reading on the receive spectrum analyzer. For LTE signals, RBW = 1-5% of the OBW, not to exceed 1MHz, VBW ≥ 3 x RBW, Detector = RMS. A Horn antenna was substituted in place of the EUT. This Horn antenna was driven by a signal generator and the level of the signal generator was adjusted to obtain the same receive spectrum analyzer reading. The conducted power at the terminals of the Horn antenna is measured. The difference between the gain of the horn and an isotropic antenna is

taken into consideration and the EIRP is recorded.

Also, we have done x, y, z planes in EUT and horizontal and vertical polarization in detecting antenna. The worst case of the EUT is x plane in LTE mode. Also worst case of detecting Antenna is horizontal polarization in LTE mode.

We were attached the results of standalone with wireless charging cover (close). Because the results of close condition is higher than open condition.

7.2 EFFECTIVE RADIATED POWER (Band 5) _ Standalone with normal cover

Freq (MHz)	Bandwidth	Modulation	Measured Level (dBm)	Substitute Level (dBm)	Ant. Gain(dBd)	C.L	Pol	ERP	
								W	dBm
824.7	1.4 MHz	QPSK	-32.42	29.51	-10.59	0.88	H	0.064	18.04
		16-QAM	-33.87	28.06	-10.59	0.88	H	0.046	16.59
836.5		QPSK	-33.47	28.21	-10.54	0.89	H	0.048	16.78
		16-QAM	-34.74	26.94	-10.54	0.89	H	0.036	15.51
848.3		QPSK	-33.16	27.80	-10.49	0.89	H	0.044	16.42
		16-QAM	-34.11	26.85	-10.49	0.89	H	0.035	15.47

Effective Radiated Power Data (1.4 MHz Band 5 LTE)

Note: All of RB size has been tested for emissions and ERP, with the 1RB configuration observed as the worst case

Freq (MHz)	Bandwidth	Modulation	Measured Level (dBm)	Substitute Level (dBm)	Ant. Gain(dBd)	C.L	Pol	ERP	
								W	dBm
825.5	3 MHz	QPSK	-32.57	29.43	-10.59	0.88	H	0.063	17.96
		16-QAM	-33.80	28.20	-10.59	0.88	H	0.047	16.73
836.5		QPSK	-33.75	27.93	-10.54	0.89	H	0.045	16.50
		16-QAM	-34.73	26.95	-10.54	0.89	H	0.036	15.52
847.5		QPSK	-33.14	27.85	-10.49	0.89	H	0.044	16.47
		16-QAM	-34.13	26.86	-10.49	0.89	H	0.035	15.48

Effective Radiated Power Data (3 MHz Band 5 LTE)

Note: All of RB size has been tested for emissions and ERP, with the 1RB configuration observed as the worst case

Freq (MHz)	Bandwidth	Modulation	Measured Level (dBm)	Substitute Level (dBm)	Ant. Gain(dBd)	C.L	Pol	ERP	
								W	dBm
826.5	5 MHz	QPSK	-32.53	29.57	-10.58	0.88	H	0.065	18.11
		16-QAM	-33.91	28.19	-10.58	0.88	H	0.047	16.73
836.5		QPSK	-33.57	28.11	-10.54	0.89	H	0.047	16.68
		16-QAM	-34.83	26.85	-10.54	0.89	H	0.035	15.42
846.5		QPSK	-32.98	28.08	-10.50	0.89	H	0.047	16.69
		16-QAM	-34.40	26.66	-10.50	0.89	H	0.034	15.27

Effective Radiated Power Data (5 MHz Band 5 LTE)

Note: All of RB size has been tested for emissions and ERP, with the 1RB configuration observed as the worst case

Freq (MHz)	Bandwidth	Modulation	Measured Level (dBm)	Substitute Level (dBm)	Ant. Gain(dBd)	C.L	Pol	ERP	
								W	dBm
829.0	10 MHz	QPSK	-32.62	29.20	-10.57	0.88	H	0.060	17.75
		16-QAM	-33.91	27.91	-10.57	0.88	H	0.044	16.46
836.5		QPSK	-33.18	28.50	-10.54	0.89	H	0.051	17.07
		16-QAM	-34.45	27.23	-10.54	0.89	H	0.038	15.80
844.0		QPSK	-33.40	27.99	-10.51	0.89	H	0.046	16.59
		16-QAM	-34.60	26.79	-10.51	0.89	H	0.035	15.39

Effective Radiated Power Data (10 MHz Band 5 LTE)

Note: All of RB size has been tested for emissions and ERP, with the 1RB configuration observed as the worst case

NOTES:

Effective Radiated Power Output Measurements by Substitution Method

according to ANSI/TIA/EIA-603-D-2010 June 24, 2010:

The EUT was placed on a non-conductive styrofoam resin table 3-meters from the receive antenna. The receive antenna height and turntable rotation was adjusted for the highest reading on the receive spectrum analyzer. For LTE signals, RBW = 1-5% of the OBW, not to exceed 1MHz, VBW ≥ 3 x RBW, Detector = RMS.

A half-wave dipole was substituted in place of the EUT. This dipole antenna was driven by a signal generator and the level of the signal generator was adjusted to obtain the same receive spectrum analyzer reading. The conducted power at the terminals of the dipole is measured. The ERP is recorded.

Also, we have done x, y, z planes in EUT and horizontal and vertical polarization in detecting antenna. The worst case of the EUT is z plane in LTE mode. Also worst case of detecting Antenna is horizontal polarization in LTE mode.

We were attached the results of standalone with wireless charging cover (close). Because the results of close condition is higher than open condition.

7.3 EQUIVALENT ISOTROPIC RADIATED POWER (Band 2) _ Standalone with wireless charging cover (close)

Freq (MHz)	Band Width (MHz)	Modulation	Measured Level (dBm)	Substitute Level (dBm)	Ant. Gain(dBi)	C.L	Pol	EIRP	
								W	dBm
1850.7	1.4	QPSK	-17.65	15.04	10.04	1.36	H	0.235	23.72
		16-QAM	-18.96	13.73	10.04	1.36	H	0.174	22.41
1880.0		QPSK	-17.98	14.98	10.05	1.37	H	0.232	23.66
		16-QAM	-19.54	13.42	10.05	1.37	H	0.162	22.10
1909.3		QPSK	-18.68	14.52	10.06	1.38	H	0.209	23.20
		16-QAM	-19.96	13.24	10.06	1.38	H	0.156	21.92

Equivalent Isotropic Radiated Power Output Data (1.4 MHz Band 2 LTE)

Note: All of RB size has been tested for emissions and EIRP, with the 1RB configuration observed as the worst case

Freq (MHz)	Band Width (MHz)	Modulation	Measured Level (dBm)	Substitute Level (dBm)	Ant. Gain(dBi)	C.L	Pol	EIRP	
								W	dBm
1851.5	3	QPSK	-17.87	14.82	10.04	1.36	H	0.224	23.50
		16-QAM	-18.96	13.73	10.04	1.36	H	0.174	22.41
1880.0		QPSK	-18.34	14.62	10.05	1.37	H	0.214	23.30
		16-QAM	-19.66	13.30	10.05	1.37	H	0.158	21.98
1908.5		QPSK	-18.85	14.32	10.06	1.38	H	0.200	23.00
		16-QAM	-20.11	13.06	10.06	1.38	H	0.149	21.74

Equivalent Isotropic Radiated Power Output Data (3 MHz Band 2 LTE)

Note: All of RB size has been tested for emissions and EIRP, with the 1RB configuration observed as the worst case

Freq (MHz)	Band Width (MHz)	Modulation	Measured Level (dBm)	Substitute Level (dBm)	Ant. Gain(dBi)	C.L	Pol	EIRP	
								W	dBm
1852.5	5	QPSK	-17.79	14.90	10.04	1.36	H	0.228	23.58
		16-QAM	-18.99	13.70	10.04	1.36	H	0.173	22.38
1880.0		QPSK	-18.30	14.66	10.05	1.37	H	0.216	23.34
		16-QAM	-19.63	13.33	10.05	1.37	H	0.159	22.01
1907.5		QPSK	-18.77	14.37	10.06	1.38	H	0.202	23.05
		16-QAM	-20.11	13.03	10.06	1.38	H	0.148	21.71

Equivalent Isotropic Radiated Power Output Data (5 MHz Band 2 LTE)

Note: All of RB size has been tested for emissions and EIRP, with the 1RB configuration observed as the worst case

Freq (MHz)	Band Width (MHz)	Modulation	Measured Level (dBm)	Substitute Level (dBm)	Ant. Gain(dBi)	C.L	Pol	EIRP	
								W	dBm
1855.0	10	QPSK	-17.63	15.06	10.04	1.36	H	0.236	23.74
		16-QAM	-18.83	13.86	10.04	1.36	H	0.179	22.54
1880.0		QPSK	-18.26	14.69	10.05	1.37	H	0.217	23.37
		16-QAM	-19.59	13.36	10.05	1.37	H	0.160	22.04
1905.0		QPSK	-18.61	14.45	10.05	1.38	H	0.205	23.12
		16-QAM	-19.93	13.13	10.05	1.38	H	0.151	21.80

Equivalent Isotropic Radiated Power Output Data (10 MHz Band 2 LTE)

Note: All of RB size has been tested for emissions and EIRP, with the 1RB configuration observed as the worst case

Freq (MHz)	Band Width (MHz)	Modulation	Measured Level (dBm)	Substitute Level (dBm)	Ant. Gain(dBi)	C.L	Pol	EIRP	
								W	dBm
1857.5	15	QPSK	-17.09	15.60	10.04	1.36	H	0.268	24.28
		16-QAM	-18.40	14.29	10.04	1.36	H	0.198	22.97
1880.0		QPSK	-17.58	15.36	10.04	1.36	H	0.253	24.04
		16-QAM	-18.95	13.99	10.04	1.36	H	0.185	22.67
1902.5		QPSK	-18.01	15.04	10.05	1.38	H	0.235	23.71
		16-QAM	-19.18	13.87	10.05	1.38	H	0.180	22.54

Equivalent Isotropic Radiated Power Output Data (15 MHz Band 2 LTE)

Note: All of RB size has been tested for emissions and EIRP, with the 1RB configuration observed as the worst case

Freq (MHz)	Band Width (MHz)	Modulation	Measured Level (dBm)	Substitute Level (dBm)	Ant. Gain(dBi)	C.L	Pol	EIRP	
								W	dBm
1860.0	20	QPSK	-17.20	15.49	10.04	1.36	H	0.261	24.17
		16-QAM	-18.19	14.50	10.04	1.36	H	0.208	23.18
1880.0		QPSK	-17.45	15.48	10.04	1.36	H	0.261	24.16
		16-QAM	-18.54	14.39	10.04	1.36	H	0.203	23.07
1900.0		QPSK	-17.90	15.16	10.05	1.38	H	0.242	23.83
		16-QAM	-18.93	14.13	10.05	1.38	H	0.191	22.80

Equivalent Isotropic Radiated Power Output Data (20 MHz Band 2 LTE)

Note: All of RB size has been tested for emissions and EIRP, with the 1RB configuration observed as the worst case

NOTES:

Equivalent Isotropic Radiated Power Measurements by Substitution Method according to ANSI/TIA/EIA-603-D-2010 June 24, 2010:

The EUT was placed on a non-conductive styrofoam resin table 3-meters from the receive antenna. Turntable rotation was adjusted for the highest reading on the receive spectrum analyzer. For LTE signals, RBW = 1-5% of the OBW, not to exceed 1MHz, VBW ≥ 3 x RBW, Detector = RMS. A Horn antenna was substituted in place of the EUT. This Horn antenna was driven by a signal generator and the level of the signal generator was adjusted to obtain the same receive spectrum analyzer reading. The conducted power at the terminals

of the Horn antenna is measured. The difference between the gain of the horn and an isotropic antenna is taken into consideration and the EIRP is recorded.

Also, we have done x, y, z planes in EUT and horizontal and vertical polarization in detecting antenna. The worst case of the EUT is x plane in LTE mode. Also worst case of detecting Antenna is horizontal polarization in LTE mode.

We were attached the results of standalone with wireless charging cover (close). Because the results of close condition is higher than open condition.

7.4 EFFECTIVE RADIATED POWER (Band 5) _ Standalone with wireless charging cover (close)

Freq (MHz)	Bandwidth	Modulation	Measured Level (dBm)	Substitute Level (dBm)	Ant. Gain(dBd)	C.L	Pol	ERP	
								W	dBm
824.7	1.4 MHz	QPSK	-32.21	29.72	-10.59	0.88	V	0.067	18.25
		16-QAM	-33.54	28.39	-10.59	0.88	V	0.049	16.92
836.5		QPSK	-32.62	29.06	-10.54	0.89	V	0.058	17.63
		16-QAM	-33.98	27.70	-10.54	0.89	V	0.042	16.27
848.3		QPSK	-32.51	28.45	-10.49	0.89	V	0.051	17.07
		16-QAM	-33.76	27.20	-10.49	0.89	V	0.038	15.82

Effective Radiated Power Data (1.4 MHz Band 5 LTE)

Note: All of RB size has been tested for emissions and ERP, with the 1RB configuration observed as the worst case

Freq (MHz)	Bandwidth	Modulation	Measured Level (dBm)	Substitute Level (dBm)	Ant. Gain(dBd)	C.L	Pol	ERP	
								W	dBm
825.5	3 MHz	QPSK	-33.09	28.91	-10.59	0.88	V	0.055	17.44
		16-QAM	-34.32	27.68	-10.59	0.88	V	0.042	16.21
836.5		QPSK	-33.14	28.54	-10.54	0.89	V	0.051	17.11
		16-QAM	-34.22	27.46	-10.54	0.89	V	0.040	16.03
847.5		QPSK	-32.46	28.53	-10.49	0.89	V	0.052	17.15
		16-QAM	-33.34	27.65	-10.49	0.89	V	0.042	16.27

Effective Radiated Power Data (3 MHz Band 5 LTE)

Note: All of RB size has been tested for emissions and ERP, with the 1RB configuration observed as the worst case

Freq (MHz)	Bandwidth	Modulation	Measured Level (dBm)	Substitute Level (dBm)	Ant. Gain(dBd)	C.L	Pol	ERP	
								W	dBm
826.5	5 MHz	QPSK	-32.98	29.12	-10.58	0.88	V	0.058	17.66
		16-QAM	-34.29	27.81	-10.58	0.88	V	0.043	16.35
836.5		QPSK	-33.01	28.67	-10.54	0.89	V	0.053	17.24
		16-QAM	-34.30	27.38	-10.54	0.89	V	0.039	15.95
846.5		QPSK	-32.21	28.85	-10.50	0.89	V	0.056	17.46
		16-QAM	-33.48	27.58	-10.50	0.89	V	0.042	16.19

Effective Radiated Power Data (5 MHz Band 5 LTE)

Note: All of RB size has been tested for emissions and ERP, with the 1RB configuration observed as the worst case

Freq (MHz)	Bandwidth	Modulation	Measured Level (dBm)	Substitute Level (dBm)	Ant. Gain(dBd)	C.L	Pol	ERP	
								W	dBm
829.0	10 MHz	QPSK	-32.95	28.87	-10.57	0.88	V	0.055	17.42
		16-QAM	-34.25	27.57	-10.57	0.88	V	0.041	16.12
836.5		QPSK	-32.84	28.84	-10.54	0.89	V	0.055	17.41
		16-QAM	-34.07	27.61	-10.54	0.89	V	0.041	16.18
844.0		QPSK	-32.44	28.95	-10.51	0.89	V	0.057	17.55
		16-QAM	-33.84	27.55	-10.51	0.89	V	0.041	16.15

Effective Radiated Power Data (10 MHz Band 5 LTE)

Note: All of RB size has been tested for emissions and ERP, with the 1RB configuration observed as the worst case

NOTES:

Effective Radiated Power Output Measurements by Substitution Method

according to ANSI/TIA/EIA-603-D-2010 June 24, 2010:

The EUT was placed on a non-conductive styrofoam resin table 3-meters from the receive antenna. The receive antenna height and turntable rotation was adjusted for the highest reading on the receive spectrum analyzer. For LTE signals, RBW = 1-5% of the OBW, not to exceed 1MHz, VBW ≥ 3 x RBW, Detector = RMS.

A half-wave dipole was substituted in place of the EUT. This dipole antenna was driven by a signal generator and the level of the signal generator was adjusted to obtain the same receive spectrum analyzer reading. The conducted power at the terminals of the dipole is measured. The ERP is recorded.

Also, we have done x, y, z planes in EUT and horizontal and vertical polarization in detecting antenna. The worst case of the EUT is y plane in LTE mode. Also worst case of detecting Antenna is vertical polarization in LTE mode.

We were attached the results of standalone with wireless charging cover (close). Because the results of close condition is higher than open condition.

7.5 EQUIVALENT ISOTROPIC RADIATED POWER (Band 2) _ With wireless charging pad

Freq (MHz)	Band Width (MHz)	Modulation	Measured Level (dBm)	Substitute Level (dBm)	Ant. Gain(dBi)	C.L	Pol	EIRP	
								W	dBm
1850.7	1.4	QPSK	-20.39	12.30	10.04	1.36	V	0.125	20.98
		16-QAM	-21.82	10.87	10.04	1.36	V	0.090	19.55
1880.0		QPSK	-21.27	11.69	10.05	1.37	V	0.109	20.37
		16-QAM	-22.79	10.17	10.05	1.37	V	0.077	18.85
1909.3		QPSK	-22.52	10.68	10.06	1.38	V	0.086	19.36
		16-QAM	-23.83	9.37	10.06	1.38	V	0.064	18.05

Equivalent Isotropic Radiated Power Output Data (1.4 MHz Band 2 LTE)

Note: All of RB size has been tested for emissions and EIRP, with the 1RB configuration observed as the worst case

Freq (MHz)	Band Width (MHz)	Modulation	Measured Level (dBm)	Substitute Level (dBm)	Ant. Gain(dBi)	C.L	Pol	EIRP	
								W	dBm
1851.5	3	QPSK	-20.68	12.01	10.04	1.36	V	0.117	20.69
		16-QAM	-21.70	10.99	10.04	1.36	V	0.093	19.67
1880.0		QPSK	-21.61	11.35	10.05	1.37	V	0.101	20.03
		16-QAM	-22.93	10.03	10.05	1.37	V	0.074	18.71
1908.5		QPSK	-22.63	10.54	10.06	1.38	V	0.084	19.22
		16-QAM	-23.89	9.28	10.06	1.38	V	0.063	17.96

Equivalent Isotropic Radiated Power Output Data (3 MHz Band 2 LTE)

Note: All of RB size has been tested for emissions and EIRP, with the 1RB configuration observed as the worst case

Freq (MHz)	Band Width (MHz)	Modulation	Measured Level (dBm)	Substitute Level (dBm)	Ant. Gain(dBi)	C.L	Pol	EIRP	
								W	dBm
1852.5	5	QPSK	-20.60	12.09	10.04	1.36	V	0.119	20.77
		16-QAM	-21.78	10.91	10.04	1.36	V	0.091	19.59
1880.0		QPSK	-21.54	11.42	10.05	1.37	V	0.102	20.10
		16-QAM	-22.88	10.08	10.05	1.37	V	0.075	18.76
1907.5		QPSK	-22.53	10.61	10.06	1.38	V	0.085	19.29
		16-QAM	-23.81	9.33	10.06	1.38	V	0.063	18.01

Equivalent Isotropic Radiated Power Output Data (5 MHz Band 2 LTE)

Note: All of RB size has been tested for emissions and EIRP, with the 1RB configuration observed as the worst case

Freq (MHz)	Band Width (MHz)	Modulation	Measured Level (dBm)	Substitute Level (dBm)	Ant. Gain(dBi)	C.L	Pol	EIRP	
								W	dBm
1855.0	10	QPSK	-20.46	12.23	10.04	1.36	V	0.123	20.91
		16-QAM	-21.65	11.04	10.04	1.36	V	0.094	19.72
1880.0		QPSK	-21.50	11.45	10.05	1.37	V	0.103	20.13
		16-QAM	-22.73	10.22	10.05	1.37	V	0.078	18.90
1905.0		QPSK	-22.38	10.68	10.05	1.38	V	0.086	19.35
		16-QAM	-23.62	9.44	10.05	1.38	V	0.065	18.11

Equivalent Isotropic Radiated Power Output Data (10 MHz Band 2 LTE)

Note: All of RB size has been tested for emissions and EIRP, with the 1RB configuration observed as the worst case

Freq (MHz)	Band Width (MHz)	Modulation	Measured Level (dBm)	Substitute Level (dBm)	Ant. Gain(dBi)	C.L	Pol	EIRP	
								W	dBm
1857.5	15	QPSK	-20.04	12.65	10.04	1.36	V	0.136	21.33
		16-QAM	-21.27	11.42	10.04	1.36	V	0.102	20.10
1880.0		QPSK	-20.73	12.21	10.04	1.36	V	0.123	20.89
		16-QAM	-22.14	10.80	10.04	1.36	V	0.089	19.48
1902.5		QPSK	-21.89	11.16	10.05	1.38	V	0.096	19.83
		16-QAM	-23.10	9.95	10.05	1.38	V	0.073	18.62

Equivalent Isotropic Radiated Power Output Data (15 MHz Band 2 LTE)

Note: All of RB size has been tested for emissions and EIRP, with the 1RB configuration observed as the worst case

Freq (MHz)	Band Width (MHz)	Modulation	Measured Level (dBm)	Substitute Level (dBm)	Ant. Gain(dBi)	C.L	Pol	EIRP	
								W	dBm
1860.0	20	QPSK	-20.00	12.69	10.04	1.36	V	0.137	21.37
		16-QAM	-21.03	11.66	10.04	1.36	V	0.108	20.34
1880.0		QPSK	-20.78	12.15	10.04	1.36	V	0.121	20.83
		16-QAM	-21.83	11.10	10.04	1.36	V	0.095	19.78
1900.0		QPSK	-21.71	11.35	10.05	1.38	V	0.100	20.02
		16-QAM	-22.76	10.30	10.05	1.38	V	0.079	18.97

Equivalent Isotropic Radiated Power Output Data (20 MHz Band 2 LTE)

Note: All of RB size has been tested for emissions and EIRP, with the 1RB configuration observed as the worst case

NOTES:

Equivalent Isotropic Radiated Power Measurements by Substitution Method

according to ANSI/TIA/EIA-603-D-2010 June 24, 2010:

The EUT was placed on a non-conductive styrofoam resin table 3-meters from the receive antenna. Turntable rotation was adjusted for the highest reading on the receive spectrum analyzer. For LTE signals, RBW = 1-5% of the OBW, not to exceed 1MHz, VBW ≥ 3 x RBW, Detector = RMS. A Horn antenna was substituted in place of the EUT. This Horn antenna was driven by a signal generator and the level of the signal generator was adjusted to obtain the same receive spectrum analyzer reading. The conducted power at the terminals

of the Horn antenna is measured. The difference between the gain of the horn and an isotropic antenna is taken into consideration and the EIRP is recorded.

Also, we have done x, y, z planes in EUT and horizontal and vertical polarization in detecting antenna. The worst case of the EUT is y plane in LTE mode. Also worst case of detecting Antenna is vertical polarization in LTE mode.

We were attached the results of standalone with wireless charging cover (close). Because the results of close condition is higher than open condition.

7.6 EFFECTIVE RADIATED POWER (Band 5) _ With wireless charging pad

Freq (MHz)	Bandwidth	Modulation	Measured Level (dBm)	Substitute Level (dBm)	Ant. Gain(dBd)	C.L	Pol	ERP	
								W	dBm
824.7	1.4 MHz	QPSK	-32.87	29.06	-10.59	0.88	V	0.057	17.59
		16-QAM	-34.36	27.57	-10.59	0.88	V	0.041	16.10
836.5		QPSK	-32.88	28.80	-10.54	0.89	V	0.055	17.37
		16-QAM	-34.05	27.63	-10.54	0.89	V	0.042	16.20
848.3		QPSK	-33.18	27.78	-10.49	0.89	V	0.044	16.40
		16-QAM	-33.73	27.23	-10.49	0.89	V	0.038	15.85

Effective Radiated Power Data (1.4 MHz Band 5 LTE)

Note: All of RB size has been tested for emissions and ERP, with the 1RB configuration observed as the worst case

Freq (MHz)	Bandwidth	Modulation	Measured Level (dBm)	Substitute Level (dBm)	Ant. Gain(dBd)	C.L	Pol	ERP	
								W	dBm
825.5	3 MHz	QPSK	-32.84	29.16	-10.59	0.88	V	0.059	17.69
		16-QAM	-34.36	27.64	-10.59	0.88	V	0.041	16.17
836.5		QPSK	-33.11	28.57	-10.54	0.89	V	0.052	17.14
		16-QAM	-34.10	27.58	-10.54	0.89	V	0.041	16.15
847.5		QPSK	-32.63	28.36	-10.49	0.89	V	0.050	16.98
		16-QAM	-33.57	27.42	-10.49	0.89	V	0.040	16.04

Effective Radiated Power Data (3 MHz Band 5 LTE)

Note: All of RB size has been tested for emissions and ERP, with the 1RB configuration observed as the worst case

Freq (MHz)	Bandwidth	Modulation	Measured Level (dBm)	Substitute Level (dBm)	Ant. Gain(dBd)	C.L	Pol	ERP	
								W	dBm
826.5	5 MHz	QPSK	-32.87	29.23	-10.58	0.88	V	0.060	17.77
		16-QAM	-34.38	27.72	-10.58	0.88	V	0.042	16.26
836.5		QPSK	-32.98	28.70	-10.54	0.89	V	0.053	17.27
		16-QAM	-34.23	27.45	-10.54	0.89	V	0.040	16.02
846.5		QPSK	-32.02	29.04	-10.50	0.89	V	0.058	17.65
		16-QAM	-33.68	27.38	-10.50	0.89	V	0.040	15.99

Effective Radiated Power Data (5 MHz Band 5 LTE)

Note: All of RB size has been tested for emissions and ERP, with the 1RB configuration observed as the worst case

Freq (MHz)	Bandwidth	Modulation	Measured Level (dBm)	Substitute Level (dBm)	Ant. Gain(dBd)	C.L	Pol	ERP	
								W	dBm
829.0	10 MHz	QPSK	-32.95	28.87	-10.57	0.88	V	0.055	17.42
		16-QAM	-34.12	27.70	-10.57	0.88	V	0.042	16.25
836.5		QPSK	-32.71	28.97	-10.54	0.89	V	0.057	17.54
		16-QAM	-34.16	27.52	-10.54	0.89	V	0.041	16.09
844.0		QPSK	-32.52	28.87	-10.51	0.89	V	0.056	17.47
		16-QAM	-33.63	27.76	-10.51	0.89	V	0.043	16.36

Effective Radiated Power Data (10 MHz Band 5 LTE)

Note: All of RB size has been tested for emissions and ERP, with the 1RB configuration observed as the worst case

NOTES:

Effective Radiated Power Output Measurements by Substitution Method

according to ANSI/TIA/EIA-603-D-2010 June 24, 2010:

The EUT was placed on a non-conductive styrofoam resin table 3-meters from the receive antenna. The receive antenna height and turntable rotation was adjusted for the highest reading on the receive spectrum analyzer. For LTE signals, RBW = 1-5% of the OBW, not to exceed 1MHz, VBW ≥ 3 x RBW, Detector = RMS.

A half-wave dipole was substituted in place of the EUT. This dipole antenna was driven by a signal generator and the level of the signal generator was adjusted to obtain the same receive spectrum analyzer reading. The conducted power at the terminals of the dipole is measured. The ERP is recorded.

Also, we have done x, y, z planes in EUT and horizontal and vertical polarization in detecting antenna. The worst case of the EUT is y plane in LTE mode. Also worst case of detecting Antenna is vertical polarization in LTE mode.

We were attached the results of standalone with wireless charging cover (close). Because the results of close condition is higher than open condition.

7.7 RADIATED SPURIOUS EMISSIONS _ Standalone with normal cover

7.7.1 RADIATED SPURIOUS EMISSIONS (1.4 MHz Band 2 LTE)

■ OPERATING FREQUENCY :	<u>1850.70 MHz</u>
■ MEASURED OUTPUT POWER:	<u>23.07 dBm = 0.203 W</u>
■ MODULATION SIGNAL:	<u>1.4 MHz QPSK</u>
■ DISTANCE:	<u>3 meters</u>
■ LIMIT: $43 + 10 \log_{10}(W) =$	<u>36.07 dBc</u>

Ch	Freq (MHz)	Measured Level (dBm)	Ant. Gain (dBi)	Substitute Level (dBm)	C.L	Pol	EIRP (dBm)	dBc
18607 (1850.7)	3,701.40	-33.81	12.32	-37.47	2.02	H	-27.17	50.24
	5,552.10	-54.27	13.02	-53.15	2.52	H	-42.65	65.72
	7,402.80	-56.34	11.06	-46.97	2.91	H	-38.82	61.89
18900 (1880.0)	3,760.00	-38.15	12.29	-41.75	1.93	H	-31.39	54.46
	5,640.00	-51.19	13.12	-50.26	2.57	V	-39.71	62.78
	7,520.00	-54.62	11.09	-45.78	3.03	H	-37.72	60.79
19193 (1909.3)	3,818.60	-39.05	12.28	-42.08	2.04	H	-31.84	54.91
	5,727.90	-51.46	13.06	-50.27	2.55	V	-39.76	62.83
	7,637.20	-51.80	11.37	-42.36	3.13	H	-34.12	57.19

NOTES: 1. Radiated Spurious Emission Measurements at 3 meters by Substitution Method

according to ANSI/TIA/EIA-603-D-2010 June 24, 2010:

2. We are performed all frequency to 10th harmonics from 30 MHz. Measurements above show only up to 3 maximum emissions noted, or would be lesser if no specific emissions from the EUT are recorded (ie: margin > 20 dB from the applicable limit) and considered that's already beyond the background noise floor.
3. we have done x, y, z planes in EUT and horizontal and vertical polarization in detecting antenna.
4. All of RB size has been tested for emissions and EIRP, with the 1RB configuration observed as the worst case
5. We are performed 16QAM and QPSK modulations. The worst case data are reported in the table above.
6. We were attached the results of standalone with wireless charging cover (close). Because the results of close condition is higher than open condition.

7.7.2 RADIATED SPURIOUS EMISSIONS (3 MHz Band 2 LTE)

- OPERATING FREQUENCY : 1851.50 MHz
- MEASURED OUTPUT POWER: 22.76 dBm = 0.189 W
- MODULATION SIGNAL: 3 MHz QPSK
- DISTANCE: 3 meters
- LIMIT: $43 + 10 \log_{10}(W) =$ 35.76 dBc

Ch	Freq (MHz)	Measured Level (dBm)	Ant. Gain (dBi)	Substitute Level (dBm)	C.L	Pol	EIRP (dBm)	dBc
18615 (1851.5)	3,703.00	-33.24	12.32	-36.88	2.02	H	-26.58	49.34
	5,554.50	-55.87	13.03	-54.76	2.52	V	-44.25	67.01
	7,406.00	-55.31	11.05	-45.87	2.92	H	-37.74	60.50
18900 (1880.0)	3,760.00	-40.23	12.29	-43.83	1.93	H	-33.47	56.23
	5,640.00	-53.10	13.12	-52.17	2.57	V	-41.62	64.38
	7,520.00	-56.61	11.09	-47.77	3.03	H	-39.71	62.47
19185 (1908.5)	3,817.00	-40.65	12.28	-43.76	2.04	H	-33.52	56.28
	5,725.50	-50.97	13.07	-49.78	2.56	V	-39.27	62.03
	7,634.00	-54.99	11.37	-45.54	3.16	V	-37.33	60.09

- NOTES:**
1. Radiated Spurious Emission Measurements at 3 meters by Substitution Method according to ANSI/TIA/EIA-603-D-2010 June 24, 2010:
 2. We are performed all frequency to 10th harmonics from 30 MHz. Measurements above show only up to 3 maximum emissions noted, or would be lesser if no specific emissions from the EUT are recorded (ie: margin > 20 dB from the applicable limit) and considered that's already beyond the background noise floor.
 3. we have done x, y, z planes in EUT and horizontal and vertical polarization in detecting antenna.
 4. All of RB size has been tested for emissions and EIRP, with the 1RB configuration observed as the worst case
 5. We are performed 16QAM and QPSK modulations. The worst case data are reported in the table above.
 6. We were attached the results of standalone with wireless charging cover (close). Because the results of close condition is higher than open condition.

7.7.3 RADIATED SPURIOUS EMISSIONS (5 MHz Band 2 LTE)

- ▣ OPERATING FREQUENCY : 1852.50 MHz
- ▣ MEASURED OUTPUT POWER: 22.84 dBm = 0.192 W
- ▣ MODULATION SIGNAL: 5 MHz QPSK
- ▣ DISTANCE: 3 meters
- ▣ LIMIT: $43 + 10 \log_{10} (W) =$ 35.84 dBc

Ch	Freq (MHz)	Measured Level (dBm)	Ant. Gain (dBi)	Substitute Level (dBm)	C.L	Pol	EIRP (dBm)	dBc
18625 (1852.5)	3,705.00	-33.47	12.32	-37.10	2.01	H	-26.79	49.63
	5,557.50	-53.54	13.04	-52.42	2.53	V	-41.91	64.75
	7,410.00	-55.24	11.05	-45.74	2.92	V	-37.61	60.45
18900 (1880.0)	3,760.00	-38.84	12.29	-42.44	1.93	H	-32.08	54.92
	5,640.00	-49.91	13.12	-48.98	2.57	V	-38.43	61.27
	7,520.00	-55.43	11.09	-46.59	3.03	V	-38.53	61.37
19175 (1907.5)	3,815.00	-41.68	12.29	-44.89	2.04	H	-34.64	57.48
	5,722.50	-49.30	13.08	-48.11	2.57	V	-37.60	60.44
	7,630.00	-54.06	11.36	-44.60	3.19	H	-36.43	59.27

- NOTES:**
1. Radiated Spurious Emission Measurements at 3 meters by Substitution Method according to ANSI/TIA/EIA-603-D-2010 June 24, 2010:
 2. We are performed all frequency to 10th harmonics from 30 MHz. Measurements above show only up to 3 maximum emissions noted, or would be lesser if no specific emissions from the EUT are recorded (ie: margin > 20 dB from the applicable limit) and considered that's already beyond the background noise floor.
 3. we have done x, y, z planes in EUT and horizontal and vertical polarization in detecting antenna.
 4. All of RB size has been tested for emissions and EIRP, with the 1RB configuration observed as the worst case
 5. We are performed 16QAM and QPSK modulations. The worst case data are reported in the table above.
 6. We were attached the results of standalone with wireless charging cover (close). Because the results of close condition is higher than open condition.

7.7.4 RADIATED SPURIOUS EMISSIONS (10 MHz Band 2 LTE)

- OPERATING FREQUENCY : 1855.00 MHz
- MEASURED OUTPUT POWER: 23.01 dBm = 0.200 W
- MODULATION SIGNAL: 10 MHz QPSK
- DISTANCE: 3 meters
- LIMIT: $43 + 10 \log_{10}(W) =$ 36.01 dBc

Ch	Freq (MHz)	Measured Level (dBm)	Ant. Gain (dBi)	Substitute Level (dBm)	C.L	Pol	EIRP (dBm)	dBc
18650 (1855.0)	3,710.00	-34.64	12.31	-38.22	1.99	H	-27.90	50.91
	5,565.00	-53.41	13.05	-52.25	2.51	V	-41.71	64.72
	7,420.00	-56.47	11.05	-46.99	2.93	H	-38.87	61.88
18900 (1880.0)	3,760.00	-42.29	12.29	-45.89	1.93	H	-35.53	58.54
	5,640.00	-50.08	13.12	-49.15	2.57	V	-38.60	61.61
	7,520.00	-55.84	11.09	-47.00	3.03	V	-38.94	61.95
19150 (1905.0)	3,810.00	-41.54	12.29	-44.99	2.03	H	-34.73	57.74
	5,715.00	-49.81	13.10	-48.47	2.54	V	-37.91	60.92
	7,620.00	-54.17	11.33	-44.83	3.08	H	-36.58	59.59

- NOTES:**
1. Radiated Spurious Emission Measurements at 3 meters by Substitution Method according to ANSI/TIA/EIA-603-D-2010 June 24, 2010:
 2. We are performed all frequency to 10th harmonics from 30 MHz. Measurements above show only up to 3 maximum emissions noted, or would be lesser if no specific emissions from the EUT are recorded (ie: margin > 20 dB from the applicable limit) and considered that's already beyond the background noise floor.
 3. we have done x, y, z planes in EUT and horizontal and vertical polarization in detecting antenna.
 4. All of RB size has been tested for emissions and EIRP, with the 1RB configuration observed as the worst case
 5. We are performed 16QAM and QPSK modulations. The worst case data are reported in the table above.
 6. We were attached the results of standalone with wireless charging cover (close). Because the results of close condition is higher than open condition.

7.7.5 RADIATED SPURIOUS EMISSIONS (15 MHz Band 2 LTE)

- ▣ OPERATING FREQUENCY : 1857.50 MHz
- ▣ MEASURED OUTPUT POWER: 23.43 dBm = 0.220 W
- ▣ MODULATION SIGNAL: 15 MHz QPSK
- ▣ DISTANCE: 3 meters
- ▣ LIMIT: $43 + 10 \log_{10} (W) =$ 36.43 dBc

Ch	Freq (MHz)	Measured Level (dBm)	Ant. Gain (dBi)	Substitute Level (dBm)	C.L	Pol	EIRP (dBm)	dBc
18675 (1857.5)	3,715.00	-32.71	12.31	-36.40	2.03	H	-26.12	49.55
	5,572.50	-53.84	13.06	-52.62	2.50	H	-42.06	65.49
	7,430.00	-55.18	11.04	-46.02	2.92	H	-37.90	61.33
18900 (1880.0)	3,760.00	-39.23	12.29	-42.83	1.93	H	-32.47	55.90
	5,640.00	-50.20	13.12	-49.27	2.57	V	-38.72	62.15
	7,520.00	-56.34	11.09	-47.50	3.03	H	-39.44	62.87
19125 (1902.5)	3,805.00	-38.10	12.30	-41.47	2.04	H	-31.21	54.64
	5,707.50	-51.11	13.12	-49.70	2.51	V	-39.09	62.52
	7,610.00	-50.08	11.31	-40.95	3.09	V	-32.73	56.16

- NOTES:**
1. Radiated Spurious Emission Measurements at 3 meters by Substitution Method according to ANSI/TIA/EIA-603-D-2010 June 24, 2010:
 2. We are performed all frequency to 10th harmonics from 30 MHz. Measurements above show only up to 3 maximum emissions noted, or would be lesser if no specific emissions from the EUT are recorded (ie: margin > 20 dB from the applicable limit) and considered that's already beyond the background noise floor.
 3. we have done x, y, z planes in EUT and horizontal and vertical polarization in detecting antenna.
 4. All of RB size has been tested for emissions and EIRP, with the 1RB configuration observed as the worst case
 5. We are performed 16QAM and QPSK modulations. The worst case data are reported in the table above.
 6. We were attached the results of standalone with wireless charging cover (close). Because the results of close condition is higher than open condition.

7.7.6 RADIATED SPURIOUS EMISSIONS (20 MHz Band 2 LTE)

- OPERATING FREQUENCY : 1860.00 MHz
- MEASURED OUTPUT POWER: 23.41 dBm = 0.219 W
- MODULATION SIGNAL: 20 MHz QPSK
- DISTANCE: 3 meters
- LIMIT: $43 + 10 \log_{10} (W) =$ 36.41 dBc

Ch	Freq (MHz)	Measured Level (dBm)	Ant. Gain (dBi)	Substitute Level (dBm)	C.L	Pol	EIRP (dBm)	dBc
18700 (1860.0)	3,720.00	-32.88	12.31	-36.67	2.07	H	-26.43	49.84
	5,580.00	-53.69	13.07	-52.41	2.51	H	-41.85	65.26
	7,440.00	-54.01	11.04	-44.70	2.92	V	-36.58	59.99
18900 (1880.0)	3,760.00	-38.13	12.29	-41.73	1.93	H	-31.37	54.78
	5,640.00	-49.32	13.12	-48.39	2.57	V	-37.84	61.25
	7,520.00	-56.41	11.09	-47.57	3.03	V	-39.51	62.92
19100 (1900.0)	3,800.00	-37.18	12.30	-40.47	2.04	H	-30.21	53.62
	5,700.00	-51.66	13.13	-50.48	2.52	V	-39.87	63.28
	7,600.00	-54.05	11.29	-44.81	3.05	H	-36.57	59.98

- NOTES:**
1. Radiated Spurious Emission Measurements at 3 meters by Substitution Method according to ANSI/TIA/EIA-603-D-2010 June 24, 2010:
 2. We are performed all frequency to 10th harmonics from 30 MHz. Measurements above show only up to 3 maximum emissions noted, or would be lesser if no specific emissions from the EUT are recorded (ie: margin > 20 dB from the applicable limit) and considered that's already beyond the background noise floor.
 3. we have done x, y, z planes in EUT and horizontal and vertical polarization in detecting antenna.
 4. All of RB size has been tested for emissions and EIRP, with the 1RB configuration observed as the worst case
 5. We are performed 16QAM and QPSK modulations. The worst case data are reported in the table above.
 6. We were attached the results of standalone with wireless charging cover (close). Because the results of close condition is higher than open condition.

7.7.7 RADIATED SPURIOUS EMISSIONS (1.4 MHz Band 5 LTE)

- ▣ OPERATING FREQUENCY : 824.70 MHz
- ▣ MEASURED OUTPUT POWER: 18.04 dBm = 0.064 W
- ▣ MODULATION SIGNAL: 1.4 MHz QPSK
- ▣ DISTANCE: 3 meters
- ▣ LIMIT: $43 + 10 \log_{10} (W) =$ 31.04 dBc

Ch	Freq (MHz)	Measured Level (dBm)	Ant. Gain (dBd)	Substitute Level (dBm)	C.L	Pol	ERP (dBm)	dBc
20407 (824.7)	1,649.40	-53.19	9.71	-61.23	1.29	H	-52.81	70.85
	2,474.10	-57.45	10.54	-62.57	1.60	H	-53.63	71.67
	3,298.80	-56.97	12.23	-62.05	1.85	H	-51.67	69.71
20525 (836.5)	1,673.00	-53.60	9.78	-61.77	1.28	H	-53.27	71.31
	2,509.50	-57.77	10.65	-62.77	1.61	H	-53.73	71.77
	3,346.00	-57.53	12.41	-63.01	1.86	V	-52.46	70.50
20643 (848.3)	1,696.60	-51.58	9.84	-59.80	1.30	H	-51.26	69.30
	2,544.90	-57.27	10.72	-62.16	1.63	V	-53.07	71.11
	3,393.20	-55.02	12.40	-60.31	1.87	H	-49.78	67.82

- NOTES:**
1. Radiated Spurious Emission Measurements at 3 meters by Substitution Method according to ANSI/TIA/EIA-603-D-2010 June 24, 2010:
 2. We are performed all frequency to 10th harmonics from 30 MHz. Measurements above show only up to 3 maximum emissions noted, or would be lesser if no specific emissions from the EUT are recorded (ie: margin > 20 dB from the applicable limit) and considered that's already beyond the background noise floor.
 3. we have done x, y, z planes in EUT and horizontal and vertical polarization in detecting antenna.
 4. All of RB size has been tested for emissions and ERP, with the 1RB configuration observed as the worst case
 5. We are performed 16QAM and QPSK modulations. The worst case data are reported in the table above.
 6. We were attached the results of standalone with wireless charging cover (close). Because the results of close condition is higher than open condition.

7.7.8 RADIATED SPURIOUS EMISSIONS (3 MHz Band 5 LTE)

- OPERATING FREQUENCY : 825.50 MHz
- MEASURED OUTPUT POWER: 17.96 dBm = 0.063 W
- MODULATION SIGNAL: 3 MHz QPSK
- DISTANCE: 3 meters
- LIMIT: $43 + 10 \log_{10} (W) =$ 30.96 dBc

Ch	Freq (MHz)	Measured Level (dBm)	Ant. Gain (dBd)	Substitute Level (dBm)	C.L	Pol	ERP (dBm)	dBc
20415 (825.5)	1,651.00	-54.84	9.71	-62.88	1.29	H	-54.46	72.42
	2,476.50	-56.07	10.54	-61.14	1.61	V	-52.21	70.17
	3,302.00	-56.92	12.25	-62.05	1.85	V	-51.65	69.61
20525 (836.5)	1,673.00	-53.38	9.78	-61.55	1.28	H	-53.05	71.01
	2,509.50	-57.71	10.65	-62.71	1.61	H	-53.67	71.63
	3,346.00	-56.20	12.41	-61.68	1.86	H	-51.13	69.09
20635 (847.5)	1,695.00	-51.23	9.84	-59.47	1.30	H	-50.93	68.89
	2,542.50	-54.61	10.72	-59.47	1.63	H	-50.38	68.34
	3,390.00	-57.10	12.40	-62.33	1.84	H	-51.77	69.73

- NOTES:**
1. Radiated Spurious Emission Measurements at 3 meters by Substitution Method according to ANSI/TIA/EIA-603-D-2010 June 24, 2010:
 2. We are performed all frequency to 10th harmonics from 30 MHz. Measurements above show only up to 3 maximum emissions noted, or would be lesser if no specific emissions from the EUT are recorded (ie: margin > 20 dB from the applicable limit) and considered that's already beyond the background noise floor.
 3. we have done x, y, z planes in EUT and horizontal and vertical polarization in detecting antenna.
 4. All of RB size has been tested for emissions and ERP, with the 1RB configuration observed as the worst case
 5. We are performed 16QAM and QPSK modulations. The worst case data are reported in the table above.
 6. We were attached the results of standalone with wireless charging cover (close). Because the results of close condition is higher than open condition.

7.7.9 RADIATED SPURIOUS EMISSIONS (5 MHz Band 5 LTE)

- ▣ OPERATING FREQUENCY : 826.50 MHz
- ▣ MEASURED OUTPUT POWER: 18.11 dBm = 0.065 W
- ▣ MODULATION SIGNAL: 5 MHz QPSK
- ▣ DISTANCE: 3 meters
- ▣ LIMIT: $43 + 10 \log_{10} (W) =$ 31.11 dBc

Ch	Freq (MHz)	Measured Level (dBm)	Ant. Gain (dBd)	Substitute Level (dBm)	C.L	Pol	ERP (dBm)	dBc
20425 (826.5)	1,653.00	-55.27	9.72	-63.32	1.29	H	-54.89	73.00
	2,479.50	-57.47	10.54	-62.49	1.61	H	-53.56	71.67
	3,306.00	-56.48	12.26	-61.67	1.86	V	-51.27	69.38
20525 (836.5)	1,673.00	-52.64	9.78	-60.81	1.28	H	-52.31	70.42
	2,509.50	-57.42	10.65	-62.42	1.61	H	-53.38	71.49
	3,346.00	-56.86	12.41	-62.34	1.86	H	-51.79	69.90
20625 (846.5)	1,693.00	-51.32	9.83	-59.57	1.30	H	-51.04	69.15
	2,539.50	-55.20	10.71	-60.02	1.63	H	-50.94	69.05
	3,386.00	-55.54	12.40	-60.93	1.84	H	-50.37	68.48

- NOTES:**
1. Radiated Spurious Emission Measurements at 3 meters by Substitution Method according to ANSI/TIA/EIA-603-D-2010 June 24, 2010:
 2. We are performed all frequency to 10th harmonics from 30 MHz. Measurements above show only up to 3 maximum emissions noted, or would be lesser if no specific emissions from the EUT are recorded (ie: margin > 20 dB from the applicable limit) and considered that's already beyond the background noise floor.
 3. we have done x, y, z planes in EUT and horizontal and vertical polarization in detecting antenna.
 4. All of RB size has been tested for emissions and ERP, with the 1RB configuration observed as the worst case
 5. We are performed 16QAM and QPSK modulations. The worst case data are reported in the table above.
 6. We were attached the results of standalone with wireless charging cover (close). Because the results of close condition is higher than open condition.

7.7.10 RADIATED SPURIOUS EMISSIONS (10 MHz Band 5 LTE)

■ OPERATING FREQUENCY :	_____	829.00 MHz
■ MEASURED OUTPUT POWER:	_____	17.75 dBm = 0.060 W
■ MODULATION SIGNAL:	_____	10 MHz QPSK
■ DISTANCE:	_____	3 meters
■ LIMIT: $43 + 10 \log_{10}(W) =$	_____	30.75 dBc

Ch	Freq (MHz)	Measured Level (dBm)	Ant. Gain (dBd)	Substitute Level (dBm)	C.L	Pol	ERP (dBm)	dBc
20450 (829.0)	1,658.00	-53.91	9.73	-61.98	1.28	H	-53.53	71.28
	2,487.00	-57.05	10.54	-62.03	1.62	H	-53.11	70.86
	3,316.00	-56.42	12.30	-61.73	1.89	H	-51.32	69.07
20525 (836.5)	1,673.00	-52.66	9.78	-60.83	1.28	H	-52.33	70.08
	2,509.50	-56.70	10.65	-61.70	1.61	V	-52.66	70.41
	3,346.00	-56.86	12.41	-62.34	1.86	V	-51.79	69.54
20600 (844.0)	1,688.00	-54.91	9.81	-63.15	1.30	H	-54.64	72.39
	2,532.00	-52.45	10.69	-57.22	1.62	V	-48.15	65.90
	3,376.00	-55.66	12.41	-61.19	1.85	V	-50.63	68.38

NOTES: 1. Radiated Spurious Emission Measurements at 3 meters by Substitution Method

according to ANSI/TIA/EIA-603-D-2010 June 24, 2010:

2. We are performed all frequency to 10th harmonics from 30 MHz. Measurements above show only up to 3 maximum emissions noted, or would be lesser if no specific emissions from the EUT are recorded (ie: margin > 20 dB from the applicable limit) and considered that's already beyond the background noise floor.

3. we have done x, y, z planes in EUT and horizontal and vertical polarization in detecting antenna.

4. All of RB size has been tested for emissions and ERP, with the 1RB configuration observed as the worst case

5. We are performed 16QAM and QPSK modulations. The worst case data are reported in the table above.

6. We were attached the results of standalone with wireless charging cover (close). Because the results of close condition is higher than open condition.

7.8 RADIATED SPURIOUS EMISSIONS _ Standalone with wireless charging cover (close)

7.8.1 RADIATED SPURIOUS EMISSIONS (1.4 MHz Band 2 LTE)

- ▣ OPERATING FREQUENCY : _____ 1850.70 MHz
- ▣ MEASURED OUTPUT POWER: _____ 23.72 dBm = 0.235 W
- ▣ MODULATION SIGNAL: _____ 1.4 MHz QPSK
- ▣ DISTANCE: _____ 3 meters
- ▣ LIMIT: $43 + 10 \log_{10}(W) =$ _____ 36.72 dBc

Ch	Freq (MHz)	Measured Level (dBm)	Ant. Gain (dBi)	Substitute Level (dBm)	C.L	Pol	EIRP (dBm)	dBc
18607 (1850.7)	3,701.40	-33.54	12.32	-37.20	2.02	H	-26.90	50.62
	5,552.10	-53.06	13.02	-51.94	2.52	V	-41.44	65.16
	7,402.80	-56.62	11.06	-47.25	2.91	V	-39.10	62.82
18900 (1880.0)	3,760.00	-38.70	12.29	-42.30	1.93	H	-31.94	55.66
	5,640.00	-50.95	13.12	-50.02	2.57	H	-39.47	63.19
	7,520.00	-56.92	11.09	-48.08	3.03	V	-40.02	63.74
19193 (1909.3)	3,818.60	-38.20	12.28	-41.23	2.04	H	-30.99	54.71
	5,727.90	-51.69	13.06	-50.50	2.55	V	-39.99	63.71
	7,637.20	-53.99	11.37	-44.55	3.13	H	-36.31	60.03

NOTES: 1. Radiated Spurious Emission Measurements at 3 meters by Substitution Method

according to ANSI/TIA/EIA-603-D-2010 June 24, 2010:

2. We are performed all frequency to 10th harmonics from 30 MHz. Measurements above show only up to 3 maximum emissions noted, or would be lesser if no specific emissions from the EUT are recorded (ie: margin > 20 dB from the applicable limit) and considered that's already beyond the background noise floor.

3. we have done x, y, z planes in EUT and horizontal and vertical polarization in detecting antenna.

4. All of RB size has been tested for emissions and EIRP, with the 1RB configuration observed as the worst case

5. We are performed 16QAM and QPSK modulations. The worst case data are reported in the table above.

6. We were attached the results of standalone with wireless charging cover (close). Because the results of close condition is higher than open condition.

7.8.2 RADIATED SPURIOUS EMISSIONS (3 MHz Band 2 LTE)

- OPERATING FREQUENCY : 1851.50 MHz
- MEASURED OUTPUT POWER: 23.50 dBm = 0.224 W
- MODULATION SIGNAL: 3 MHz QPSK
- DISTANCE: 3 meters
- LIMIT: $43 + 10 \log_{10}(W) =$ 36.50 dBc

Ch	Freq (MHz)	Measured Level (dBm)	Ant. Gain (dBi)	Substitute Level (dBm)	C.L	Pol	EIRP (dBm)	dBc
18615 (1851.5)	3,703.00	-34.40	12.32	-38.04	2.02	H	-27.74	51.24
	5,554.50	-54.06	13.03	-52.95	2.52	V	-42.44	65.94
	7,406.00	-59.85	11.05	-50.41	2.92	H	-42.28	65.78
18900 (1880.0)	3,760.00	-40.96	12.29	-44.56	1.93	V	-34.20	57.70
	5,640.00	-52.07	13.12	-51.14	2.57	H	-40.59	64.09
	7,520.00	-56.44	11.09	-47.60	3.03	H	-39.54	63.04
19185 (1908.5)	3,817.00	-40.99	12.28	-44.10	2.04	H	-33.86	57.36
	5,725.50	-50.20	13.07	-49.01	2.56	V	-38.50	62.00
	7,634.00	-56.60	11.37	-47.15	3.16	V	-38.94	62.44

- NOTES:**
1. Radiated Spurious Emission Measurements at 3 meters by Substitution Method according to ANSI/TIA/EIA-603-D-2010 June 24, 2010:
 2. We are performed all frequency to 10th harmonics from 30 MHz. Measurements above show only up to 3 maximum emissions noted, or would be lesser if no specific emissions from the EUT are recorded (ie: margin > 20 dB from the applicable limit) and considered that's already beyond the background noise floor.
 3. we have done x, y, z planes in EUT and horizontal and vertical polarization in detecting antenna.
 4. All of RB size has been tested for emissions and EIRP, with the 1RB configuration observed as the worst case
 5. We are performed 16QAM and QPSK modulations. The worst case data are reported in the table above.
 6. We were attached the results of standalone with wireless charging cover (close). Because the results of close condition is higher than open condition.

7.8.3 RADIATED SPURIOUS EMISSIONS (5 MHz Band 2 LTE)

- ▣ OPERATING FREQUENCY : 1852.50 MHz
- ▣ MEASURED OUTPUT POWER: 23.58 dBm = 0.228 W
- ▣ MODULATION SIGNAL: 5 MHz QPSK
- ▣ DISTANCE: 3 meters
- ▣ LIMIT: $43 + 10 \log_{10} (W) =$ 36.58 dBc

Ch	Freq (MHz)	Measured Level (dBm)	Ant. Gain (dBi)	Substitute Level (dBm)	C.L	Pol	EIRP (dBm)	dBc
18625 (1852.5)	3,705.00	-34.70	12.32	-38.33	2.01	H	-28.02	51.60
	5,557.50	-35.42	13.04	-34.30	2.53	H	-23.79	47.37
	7,410.00	-57.37	11.05	-47.87	2.92	H	-39.74	63.32
18900 (1880.0)	3,760.00	-40.01	12.29	-43.61	1.93	H	-33.25	56.83
	5,640.00	-51.16	13.12	-50.23	2.57	H	-39.68	63.26
	7,520.00	-58.50	11.09	-49.66	3.03	V	-41.60	65.18
19175 (1907.5)	3,815.00	-40.90	12.29	-44.11	2.04	H	-33.86	57.44
	5,722.50	-50.30	13.08	-49.11	2.57	H	-38.60	62.18
	7,630.00	-56.16	11.36	-46.70	3.19	H	-38.53	62.11

- NOTES:**
1. Radiated Spurious Emission Measurements at 3 meters by Substitution Method according to ANSI/TIA/EIA-603-D-2010 June 24, 2010:
 2. We are performed all frequency to 10th harmonics from 30 MHz. Measurements above show only up to 3 maximum emissions noted, or would be lesser if no specific emissions from the EUT are recorded (ie: margin > 20 dB from the applicable limit) and considered that's already beyond the background noise floor.
 3. we have done x, y, z planes in EUT and horizontal and vertical polarization in detecting antenna.
 4. All of RB size has been tested for emissions and EIRP, with the 1RB configuration observed as the worst case
 5. We are performed 16QAM and QPSK modulations. The worst case data are reported in the table above.
 6. We were attached the results of standalone with wireless charging cover (close). Because the results of close condition is higher than open condition.

7.8.4 RADIATED SPURIOUS EMISSIONS (10 MHz Band 2 LTE)

- OPERATING FREQUENCY : 1855.00 MHz
- MEASURED OUTPUT POWER: 23.74 dBm = 0.236 W
- MODULATION SIGNAL: 10 MHz QPSK
- DISTANCE: 3 meters
- LIMIT: $43 + 10 \log_{10}(W) =$ 36.74 dBc

Ch	Freq (MHz)	Measured Level (dBm)	Ant. Gain (dBi)	Substitute Level (dBm)	C.L	Pol	EIRP (dBm)	dBc
18650 (1855.0)	3,710.00	-34.39	12.31	-37.97	1.99	H	-27.65	51.39
	5,565.00	-53.32	13.05	-52.16	2.51	H	-41.62	65.36
	7,420.00	-57.39	11.05	-47.91	2.93	H	-39.79	63.53
18900 (1880.0)	3,760.00	-48.81	12.29	-52.41	1.93	H	-42.05	65.79
	5,640.00	-56.72	13.12	-55.79	2.57	H	-45.24	68.98
	7,520.00	-58.36	11.09	-49.52	3.03	V	-41.46	65.20
19150 (1905.0)	3,810.00	-40.67	12.29	-44.12	2.03	H	-33.86	57.60
	5,715.00	-49.35	13.10	-48.01	2.54	V	-37.45	61.19
	7,620.00	-56.57	11.33	-47.23	3.08	H	-38.98	62.72

- NOTES:**
1. Radiated Spurious Emission Measurements at 3 meters by Substitution Method according to ANSI/TIA/EIA-603-D-2010 June 24, 2010:
 2. We are performed all frequency to 10th harmonics from 30 MHz. Measurements above show only up to 3 maximum emissions noted, or would be lesser if no specific emissions from the EUT are recorded (ie: margin > 20 dB from the applicable limit) and considered that's already beyond the background noise floor.
 3. we have done x, y, z planes in EUT and horizontal and vertical polarization in detecting antenna.
 4. All of RB size has been tested for emissions and EIRP, with the 1RB configuration observed as the worst case
 5. We are performed 16QAM and QPSK modulations. The worst case data are reported in the table above.
 6. We were attached the results of standalone with wireless charging cover (close). Because the results of close condition is higher than open condition.

7.8.5 RADIATED SPURIOUS EMISSIONS (15 MHz Band 2 LTE)

- ▣ OPERATING FREQUENCY : 1857.50 MHz
- ▣ MEASURED OUTPUT POWER: 24.28 dBm = 0.268 W
- ▣ MODULATION SIGNAL: 15 MHz QPSK
- ▣ DISTANCE: 3 meters
- ▣ LIMIT: $43 + 10 \log_{10}(W) =$ 37.28 dBc

Ch	Freq (MHz)	Measured Level (dBm)	Ant. Gain (dBi)	Substitute Level (dBm)	C.L	Pol	EIRP (dBm)	dBc
18675 (1857.5)	3,715.00	-33.78	12.31	-37.47	2.03	H	-27.19	51.47
	5,572.50	-53.70	13.06	-52.48	2.50	H	-41.92	66.20
	7,430.00	-55.64	11.04	-46.48	2.92	H	-38.36	62.64
18900 (1880.0)	3,760.00	-38.98	12.29	-42.58	1.93	H	-32.22	56.50
	5,640.00	-50.93	13.12	-50.00	2.57	H	-39.45	63.73
	7,520.00	-59.02	11.09	-50.18	3.03	V	-42.12	66.40
19125 (1902.5)	3,805.00	-39.22	12.30	-42.59	2.04	H	-32.33	56.61
	5,707.50	-48.97	13.12	-47.56	2.51	V	-36.95	61.23
	7,610.00	-52.24	11.31	-43.11	3.09	H	-34.89	59.17

- NOTES:**
1. Radiated Spurious Emission Measurements at 3 meters by Substitution Method according to ANSI/TIA/EIA-603-D-2010 June 24, 2010:
 2. We are performed all frequency to 10th harmonics from 30 MHz. Measurements above show only up to 3 maximum emissions noted, or would be lesser if no specific emissions from the EUT are recorded (ie: margin > 20 dB from the applicable limit) and considered that's already beyond the background noise floor.
 3. we have done x, y, z planes in EUT and horizontal and vertical polarization in detecting antenna.
 4. All of RB size has been tested for emissions and EIRP, with the 1RB configuration observed as the worst case
 5. We are performed 16QAM and QPSK modulations. The worst case data are reported in the table above.
 6. We were attached the results of standalone with wireless charging cover (close). Because the results of close condition is higher than open condition.

7.8.6 RADIATED SPURIOUS EMISSIONS (20 MHz Band 2 LTE)

■ OPERATING FREQUENCY :	_____	1860.00 MHz
■ MEASURED OUTPUT POWER:	_____	24.17 dBm = 0.261 W
■ MODULATION SIGNAL:	_____	20 MHz QPSK
■ DISTANCE:	_____	3 meters
■ LIMIT: $43 + 10 \log_{10} (W) =$	_____	37.17 dBc

Ch	Freq (MHz)	Measured Level (dBm)	Ant. Gain (dBi)	Substitute Level (dBm)	C.L	Pol	EIRP (dBm)	dBc
18700 (1860.0)	3,720.00	-34.29	12.31	-38.08	2.07	H	-27.84	52.01
	5,580.00	-53.65	13.07	-52.37	2.51	H	-41.81	65.98
	7,440.00	-56.30	11.04	-46.99	2.92	H	-38.87	63.04
18900 (1880.0)	3,760.00	-39.39	12.29	-42.99	1.93	H	-32.63	56.80
	5,640.00	-50.08	13.12	-49.15	2.57	H	-38.60	62.77
	7,520.00	-57.56	11.09	-48.72	3.03	H	-40.66	64.83
19100 (1900.0)	3,800.00	-37.35	12.30	-40.64	2.04	H	-30.38	54.55
	5,700.00	-51.55	13.13	-50.37	2.52	H	-39.76	63.93
	7,600.00	-52.29	11.29	-43.05	3.05	V	-34.81	58.98

NOTES: 1. Radiated Spurious Emission Measurements at 3 meters by Substitution Method

according to ANSI/TIA/EIA-603-D-2010 June 24, 2010:

2. We are performed all frequency to 10th harmonics from 30 MHz. Measurements above show only up to 3 maximum emissions noted, or would be lesser if no specific emissions from the EUT are recorded (ie: margin > 20 dB from the applicable limit) and considered that's already beyond the background noise floor.

3. we have done x, y, z planes in EUT and horizontal and vertical polarization in detecting antenna.

4. All of RB size has been tested for emissions and EIRP, with the 1RB configuration observed as the worst case

5. We are performed 16QAM and QPSK modulations. The worst case data are reported in the table above.

6. We were attached the results of standalone with wireless charging cover (close). Because the results of close condition is higher than open condition.

7.8.7 RADIATED SPURIOUS EMISSIONS (1.4 MHz Band 5 LTE)

- ▣ OPERATING FREQUENCY : 824.70 MHz
- ▣ MEASURED OUTPUT POWER: 18.25 dBm = 0.067 W
- ▣ MODULATION SIGNAL: 1.4 MHz QPSK
- ▣ DISTANCE: 3 meters
- ▣ LIMIT: $43 + 10 \log_{10} (W) =$ 31.25 dBc

Ch	Freq (MHz)	Measured Level (dBm)	Ant. Gain (dBd)	Substitute Level (dBm)	C.L	Pol	ERP (dBm)	dBc
20407 (824.7)	1,649.40	-50.01	9.71	-58.05	1.29	H	-49.63	67.88
	2,474.10	-56.08	10.54	-61.20	1.60	H	-52.26	70.51
	3,298.80	-57.14	12.23	-62.22	1.85	H	-51.84	70.09
20525 (836.5)	1,673.00	-52.75	9.78	-60.92	1.28	H	-52.42	70.67
	2,509.50	-56.59	10.65	-61.59	1.61	H	-52.55	70.80
	3,346.00	-57.49	12.41	-62.97	1.86	V	-52.42	70.67
20643 (848.3)	1,696.60	-52.12	9.84	-60.34	1.30	H	-51.80	70.05
	2,544.90	-56.74	10.72	-61.63	1.63	V	-52.54	70.79
	3,393.20	-55.34	12.40	-60.63	1.87	H	-50.10	68.35

- NOTES:**
1. Radiated Spurious Emission Measurements at 3 meters by Substitution Method according to ANSI/TIA/EIA-603-D-2010 June 24, 2010:
 2. We are performed all frequency to 10th harmonics from 30 MHz. Measurements above show only up to 3 maximum emissions noted, or would be lesser if no specific emissions from the EUT are recorded (ie: margin > 20 dB from the applicable limit) and considered that's already beyond the background noise floor.
 3. we have done x, y, z planes in EUT and horizontal and vertical polarization in detecting antenna.
 4. All of RB size has been tested for emissions and ERP, with the 1RB configuration observed as the worst case
 5. We are performed 16QAM and QPSK modulations. The worst case data are reported in the table above.
 6. We were attached the results of standalone with wireless charging cover (close). Because the results of close condition is higher than open condition.

7.8.8 RADIATED SPURIOUS EMISSIONS (3 MHz Band 5 LTE)

- OPERATING FREQUENCY : 825.50 MHz
- MEASURED OUTPUT POWER: 17.44 dBm = 0.055 W
- MODULATION SIGNAL: 3 MHz QPSK
- DISTANCE: 3 meters
- LIMIT: $43 + 10 \log_{10}(W) =$ 30.44 dBc

Ch	Freq (MHz)	Measured Level (dBm)	Ant. Gain (dBd)	Substitute Level (dBm)	C.L	Pol	ERP (dBm)	dBc
20415 (825.5)	1,651.00	-49.98	9.71	-58.02	1.29	H	-49.60	67.04
	2,476.50	-56.76	10.54	-61.83	1.61	V	-52.90	70.34
	3,302.00	-57.19	12.25	-62.32	1.85	V	-51.92	69.36
20525 (836.5)	1,673.00	-52.05	9.78	-60.22	1.28	H	-51.72	69.16
	2,509.50	-57.22	10.65	-62.22	1.61	H	-53.18	70.62
	3,346.00	-57.21	12.41	-62.69	1.86	H	-52.14	69.58
20635 (847.5)	1,695.00	-51.56	9.84	-59.80	1.30	H	-51.26	68.70
	2,542.50	-56.51	10.72	-61.37	1.63	H	-52.28	69.72
	3,390.00	-56.90	12.40	-62.13	1.84	H	-51.57	69.01

- NOTES:**
1. Radiated Spurious Emission Measurements at 3 meters by Substitution Method according to ANSI/TIA/EIA-603-D-2010 June 24, 2010:
 2. We are performed all frequency to 10th harmonics from 30 MHz. Measurements above show only up to 3 maximum emissions noted, or would be lesser if no specific emissions from the EUT are recorded (ie: margin > 20 dB from the applicable limit) and considered that's already beyond the background noise floor.
 3. we have done x, y, z planes in EUT and horizontal and vertical polarization in detecting antenna.
 4. All of RB size has been tested for emissions and ERP, with the 1RB configuration observed as the worst case
 5. We are performed 16QAM and QPSK modulations. The worst case data are reported in the table above.
 6. We were attached the results of standalone with wireless charging cover (close). Because the results of close condition is higher than open condition.

7.8.9 RADIATED SPURIOUS EMISSIONS (5 MHz Band 5 LTE)

- OPERATING FREQUENCY : 826.50 MHz
- MEASURED OUTPUT POWER: 17.66 dBm = 0.058 W
- MODULATION SIGNAL: 5 MHz QPSK
- DISTANCE: 3 meters
- LIMIT: $43 + 10 \log_{10} (W) =$ 30.66 dBc

Ch	Freq (MHz)	Measured Level (dBm)	Ant. Gain (dBd)	Substitute Level (dBm)	C.L	Pol	ERP (dBm)	dBc
20425 (826.5)	1,653.00	-50.62	9.72	-58.67	1.29	H	-50.24	67.90
	2,479.50	-56.78	10.54	-61.80	1.61	H	-52.87	70.53
	3,306.00	-56.89	12.26	-62.08	1.86	V	-51.68	69.34
20525 (836.5)	1,673.00	-51.24	9.78	-59.41	1.28	H	-50.91	68.57
	2,509.50	-57.71	10.65	-62.71	1.61	H	-53.67	71.33
	3,346.00	-56.67	12.41	-62.15	1.86	H	-51.60	69.26
20625 (846.5)	1,693.00	-51.22	9.83	-59.47	1.30	H	-50.94	68.60
	2,539.50	-53.69	10.71	-58.51	1.63	H	-49.43	67.09
	3,386.00	-54.89	12.40	-60.28	1.84	H	-49.72	67.38

- NOTES:**
1. Radiated Spurious Emission Measurements at 3 meters by Substitution Method according to ANSI/TIA/EIA-603-D-2010 June 24, 2010:
 2. We are performed all frequency to 10th harmonics from 30 MHz. Measurements above show only up to 3 maximum emissions noted, or would be lesser if no specific emissions from the EUT are recorded (ie: margin > 20 dB from the applicable limit) and considered that's already beyond the background noise floor.
 3. we have done x, y, z planes in EUT and horizontal and vertical polarization in detecting antenna.
 4. All of RB size has been tested for emissions and ERP, with the 1RB configuration observed as the worst case
 5. We are performed 16QAM and QPSK modulations. The worst case data are reported in the table above.
 6. We were attached the results of standalone with wireless charging cover (close). Because the results of close condition is higher than open condition.

7.8.10 RADIATED SPURIOUS EMISSIONS (10 MHz Band 5 LTE)

- OPERATING FREQUENCY : 844.00 MHz
- MEASURED OUTPUT POWER: 17.55 dBm = 0.057 W
- MODULATION SIGNAL: 10 MHz QPSK
- DISTANCE: 3 meters
- LIMIT: $43 + 10 \log_{10}(W) =$ 30.55 dBc

Ch	Freq (MHz)	Measured Level (dBm)	Ant. Gain (dBd)	Substitute Level (dBm)	C.L	Pol	ERP (dBm)	dBc
20450 (829.0)	1,658.00	-50.84	9.73	-58.91	1.28	H	-50.46	68.01
	2,487.00	-49.27	10.54	-54.25	1.62	H	-45.33	62.88
	3,316.00	-56.75	12.30	-62.06	1.89	H	-51.65	69.20
20525 (836.5)	1,673.00	-49.06	9.78	-57.23	1.28	H	-48.73	66.28
	2,509.50	-48.07	10.65	-53.07	1.61	V	-44.03	61.58
	3,346.00	-56.22	12.41	-61.70	1.86	V	-51.15	68.70
20600 (844.0)	1,688.00	-52.38	9.81	-60.62	1.30	H	-52.11	69.66
	2,532.00	-50.75	10.69	-55.52	1.62	V	-46.45	64.00
	3,376.00	-56.68	12.41	-62.21	1.85	V	-51.65	69.20

- NOTES:**
1. Radiated Spurious Emission Measurements at 3 meters by Substitution Method according to ANSI/TIA/EIA-603-D-2010 June 24, 2010:
 2. We are performed all frequency to 10th harmonics from 30 MHz. Measurements above show only up to 3 maximum emissions noted, or would be lesser if no specific emissions from the EUT are recorded (ie: margin > 20 dB from the applicable limit) and considered that's already beyond the background noise floor.
 3. we have done x, y, z planes in EUT and horizontal and vertical polarization in detecting antenna.
 4. All of RB size has been tested for emissions and ERP, with the 1RB configuration observed as the worst case
 5. We are performed 16QAM and QPSK modulations. The worst case data are reported in the table above.
 6. We were attached the results of standalone with wireless charging cover (close). Because the results of close condition is higher than open condition.

7.9 RADIATED SPURIOUS EMISSIONS _ With wireless charging pad

7.9.1 RADIATED SPURIOUS EMISSIONS (1.4 MHz Band 2 LTE)

■ OPERATING FREQUENCY :	_____ 1850.70 MHz
■ MEASURED OUTPUT POWER:	_____ 20.98 dBm = 0.125 W
■ MODULATION SIGNAL:	_____ 1.4 MHz QPSK
■ DISTANCE:	_____ 3 meters
■ LIMIT: $43 + 10 \log_{10}(W) =$	_____ 33.98 dBc

Ch	Freq (MHz)	Measured Level (dBm)	Ant. Gain (dBi)	Substitute Level (dBm)	C.L	Pol	EIRP (dBm)	dBc
18607 (1850.7)	3,701.40	-38.98	12.32	-42.64	2.02	H	-32.34	53.32
	5,552.10	-51.21	13.02	-50.09	2.52	V	-39.59	60.57
	7,402.80	-55.61	11.06	-46.24	2.91	H	-38.09	59.07
18900 (1880.0)	3,760.00	-40.84	12.29	-44.44	1.93	V	-34.08	55.06
	5,640.00	-50.27	13.12	-49.34	2.57	V	-38.79	59.77
	7,520.00	-56.52	11.09	-47.68	3.03	H	-39.62	60.60
19193 (1909.3)	3,818.60	-41.45	12.28	-44.48	2.04	V	-34.24	55.22
	5,727.90	-52.20	13.06	-51.01	2.55	H	-40.50	61.48
	7,637.20	-53.50	11.37	-44.06	3.13	H	-35.82	56.80

NOTES: 1. Radiated Spurious Emission Measurements at 3 meters by Substitution Method

according to ANSI/TIA/EIA-603-D-2010 June 24, 2010:

2. We are performed all frequency to 10th harmonics from 30 MHz. Measurements above show only up to 3 maximum emissions noted, or would be lesser if no specific emissions from the EUT are recorded (ie: margin > 20 dB from the applicable limit) and considered that's already beyond the background noise floor.

3. we have done x, y, z planes in EUT and horizontal and vertical polarization in detecting antenna.

4. All of RB size has been tested for emissions and EIRP, with the 1RB configuration observed as the worst case

5. We are performed 16QAM and QPSK modulations. The worst case data are reported in the table above.

6. We were attached the results of standalone with wireless charging cover (close). Because the results of close condition is higher than open condition.

7.9.2 RADIATED SPURIOUS EMISSIONS (3 MHz Band 2 LTE)

- OPERATING FREQUENCY : 1851.50 MHz
- MEASURED OUTPUT POWER: 20.69 dBm = 0.117 W
- MODULATION SIGNAL: 3 MHz QPSK
- DISTANCE: 3 meters
- LIMIT: $43 + 10 \log_{10}(W) =$ 33.69 dBc

Ch	Freq (MHz)	Measured Level (dBm)	Ant. Gain (dBi)	Substitute Level (dBm)	C.L	Pol	EIRP (dBm)	dBc
18615 (1851.5)	3,703.00	-40.42	12.32	-44.06	2.02	H	-33.76	54.45
	5,554.50	-51.42	13.03	-50.31	2.52	V	-39.80	60.49
	7,406.00	-56.35	11.05	-46.91	2.92	V	-38.78	59.47
18900 (1880.0)	3,760.00	-43.14	12.29	-46.74	1.93	H	-36.38	57.07
	5,640.00	-49.06	13.12	-48.13	2.57	V	-37.58	58.27
	7,520.00	-56.36	11.09	-47.52	3.03	H	-39.46	60.15
19185 (1908.5)	3,817.00	-42.66	12.28	-45.77	2.04	V	-35.53	56.22
	5,725.50	-49.32	13.07	-48.13	2.56	H	-37.62	58.31
	7,634.00	-56.12	11.37	-46.67	3.16	H	-38.46	59.15

NOTES: 1. Radiated Spurious Emission Measurements at 3 meters by Substitution Method

according to ANSI/TIA/EIA-603-D-2010 June 24, 2010:

2. We are performed all frequency to 10th harmonics from 30 MHz. Measurements above show only up to 3 maximum emissions noted, or would be lesser if no specific emissions from the EUT are recorded (ie: margin > 20 dB from the applicable limit) and considered that's already beyond the background noise floor.

3. we have done x, y, z planes in EUT and horizontal and vertical polarization in detecting antenna.

4. All of RB size has been tested for emissions and EIRP, with the 1RB configuration observed as the worst case

5. We are performed 16QAM and QPSK modulations. The worst case data are reported in the table above.

6. We were attached the results of standalone with wireless charging cover (close). Because the results of close condition is higher than open condition.

7.9.3 RADIATED SPURIOUS EMISSIONS (5 MHz Band 2 LTE)

- OPERATING FREQUENCY : 1852.50 MHz
- MEASURED OUTPUT POWER: 20.77 dBm = 0.119 W
- MODULATION SIGNAL: 5 MHz QPSK
- DISTANCE: 3 meters
- LIMIT: $43 + 10 \log_{10}(W) =$ 33.77 dBc

Ch	Freq (MHz)	Measured Level (dBm)	Ant. Gain (dBi)	Substitute Level (dBm)	C.L	Pol	EIRP (dBm)	dBc
18625 (1852.5)	3,705.00	-39.91	12.32	-43.54	2.01	H	-33.23	54.00
	5,557.50	-51.92	13.04	-50.80	2.53	V	-40.29	61.06
	7,410.00	-56.24	11.05	-46.74	2.92	H	-38.61	59.38
18900 (1880.0)	3,760.00	-43.16	12.29	-46.76	1.93	V	-36.40	57.17
	5,640.00	-49.51	13.12	-48.58	2.57	V	-38.03	58.80
	7,520.00	-56.88	11.09	-48.04	3.03	V	-39.98	60.75
19175 (1907.5)	3,815.00	-45.07	12.29	-48.28	2.04	H	-38.03	58.80
	5,722.50	-48.64	13.08	-47.45	2.57	H	-36.94	57.71
	7,630.00	-57.02	11.36	-47.56	3.19	V	-39.39	60.16

- NOTES:**
1. Radiated Spurious Emission Measurements at 3 meters by Substitution Method according to ANSI/TIA/EIA-603-D-2010 June 24, 2010:
 2. We are performed all frequency to 10th harmonics from 30 MHz. Measurements above show only up to 3 maximum emissions noted, or would be lesser if no specific emissions from the EUT are recorded (ie: margin > 20 dB from the applicable limit) and considered that's already beyond the background noise floor.
 3. we have done x, y, z planes in EUT and horizontal and vertical polarization in detecting antenna.
 4. All of RB size has been tested for emissions and EIRP, with the 1RB configuration observed as the worst case
 5. We are performed 16QAM and QPSK modulations. The worst case data are reported in the table above.
 6. We were attached the results of standalone with wireless charging cover (close). Because the results of close condition is higher than open condition.

7.9.4 RADIATED SPURIOUS EMISSIONS (10 MHz Band 2 LTE)

■ OPERATING FREQUENCY :	_____	1855.00 MHz
■ MEASURED OUTPUT POWER:	_____	20.91 dBm = 0.123 W
■ MODULATION SIGNAL:	_____	10 MHz QPSK
■ DISTANCE:	_____	3 meters
■ LIMIT: $43 + 10 \log_{10}(W) =$	_____	33.91 dBc

Ch	Freq (MHz)	Measured Level (dBm)	Ant. Gain (dBi)	Substitute Level (dBm)	C.L	Pol	EIRP (dBm)	dBc
18650 (1855.0)	3,710.00	-39.50	12.31	-43.08	1.99	V	-32.76	53.67
	5,565.00	-52.28	13.05	-51.12	2.51	V	-40.58	61.49
	7,420.00	-57.48	11.05	-48.00	2.93	H	-39.88	60.79
18900 (1880.0)	3,760.00	-43.92	12.29	-47.52	1.93	V	-37.16	58.07
	5,640.00	-50.00	13.12	-49.07	2.57	V	-38.52	59.43
	7,520.00	-56.35	11.09	-47.51	3.03	H	-39.45	60.36
19150 (1905.0)	3,810.00	-43.97	12.29	-47.42	2.03	H	-37.16	58.07
	5,715.00	-49.09	13.10	-47.75	2.54	V	-37.19	58.10
	7,620.00	-56.93	11.33	-47.59	3.08	V	-39.34	60.25

NOTES: 1. Radiated Spurious Emission Measurements at 3 meters by Substitution Method

according to ANSI/TIA/EIA-603-D-2010 June 24, 2010:

2. We are performed all frequency to 10th harmonics from 30 MHz. Measurements above show only up to 3 maximum emissions noted, or would be lesser if no specific emissions from the EUT are recorded (ie: margin > 20 dB from the applicable limit) and considered that's already beyond the background noise floor.

3. we have done x, y, z planes in EUT and horizontal and vertical polarization in detecting antenna.

4. All of RB size has been tested for emissions and EIRP, with the 1RB configuration observed as the worst case

5. We are performed 16QAM and QPSK modulations. The worst case data are reported in the table above.

6. We were attached the results of standalone with wireless charging cover (close). Because the results of close condition is higher than open condition.

7.9.5 RADIATED SPURIOUS EMISSIONS (15 MHz Band 2 LTE)

- ▣ OPERATING FREQUENCY : 1857.50 MHz
- ▣ MEASURED OUTPUT POWER: 21.33 dBm = 0.136 W
- ▣ MODULATION SIGNAL: 15 MHz QPSK
- ▣ DISTANCE: 3 meters
- ▣ LIMIT: $43 + 10 \log_{10} (W) =$ 34.33 dBc

Ch	Freq (MHz)	Measured Level (dBm)	Ant. Gain (dBi)	Substitute Level (dBm)	C.L	Pol	EIRP (dBm)	dBc
18675 (1857.5)	3,715.00	-39.54	12.31	-43.23	2.03	H	-32.95	54.28
	5,572.50	-51.45	13.06	-50.23	2.50	V	-39.67	61.00
	7,430.00	-54.06	11.04	-44.90	2.92	H	-36.78	58.11
18900 (1880.0)	3,760.00	-43.99	12.29	-47.59	1.93	V	-37.23	58.56
	5,640.00	-49.50	13.12	-48.57	2.57	V	-38.02	59.35
	7,520.00	-56.55	11.09	-47.71	3.03	H	-39.65	60.98
19125 (1902.5)	3,805.00	-42.46	12.30	-45.83	2.04	H	-35.57	56.90
	5,707.50	-49.91	13.12	-48.50	2.51	V	-37.89	59.22
	7,610.00	-52.53	11.31	-43.40	3.09	H	-35.18	56.51

- NOTES:**
1. Radiated Spurious Emission Measurements at 3 meters by Substitution Method according to ANSI/TIA/EIA-603-D-2010 June 24, 2010:
 2. We are performed all frequency to 10th harmonics from 30 MHz. Measurements above show only up to 3 maximum emissions noted, or would be lesser if no specific emissions from the EUT are recorded (ie: margin > 20 dB from the applicable limit) and considered that's already beyond the background noise floor.
 3. we have done x, y, z planes in EUT and horizontal and vertical polarization in detecting antenna.
 4. All of RB size has been tested for emissions and EIRP, with the 1RB configuration observed as the worst case
 5. We are performed 16QAM and QPSK modulations. The worst case data are reported in the table above.
 6. We were attached the results of standalone with wireless charging cover (close). Because the results of close condition is higher than open condition.

7.9.6 RADIATED SPURIOUS EMISSIONS (20 MHz Band 2 LTE)

- OPERATING FREQUENCY : 1860.00 MHz
- MEASURED OUTPUT POWER: 21.37 dBm = 0.137 W
- MODULATION SIGNAL: 20 MHz QPSK
- DISTANCE: 3 meters
- LIMIT: $43 + 10 \log_{10}(W) =$ 34.37 dBc

Ch	Freq (MHz)	Measured Level (dBm)	Ant. Gain (dBi)	Substitute Level (dBm)	C.L	Pol	EIRP (dBm)	dBc
18700 (1860.0)	3,720.00	-39.20	12.31	-42.99	2.07	H	-32.75	54.12
	5,580.00	-49.87	13.07	-48.59	2.51	V	-38.03	59.40
	7,440.00	-57.05	11.04	-47.74	2.92	V	-39.62	60.99
18900 (1880.0)	3,760.00	-44.51	12.29	-48.11	1.93	H	-37.75	59.12
	5,640.00	-49.07	13.12	-48.14	2.57	V	-37.59	58.96
	7,520.00	-57.06	11.09	-48.22	3.03	H	-40.16	61.53
19100 (1900.0)	3,800.00	-41.51	12.30	-44.80	2.04	H	-34.54	55.91
	5,700.00	-50.87	13.13	-49.69	2.52	V	-39.08	60.45
	7,600.00	-56.80	11.29	-47.56	3.05	V	-39.32	60.69

- NOTES:**
1. Radiated Spurious Emission Measurements at 3 meters by Substitution Method according to ANSI/TIA/EIA-603-D-2010 June 24, 2010:
 2. We are performed all frequency to 10th harmonics from 30 MHz. Measurements above show only up to 3 maximum emissions noted, or would be lesser if no specific emissions from the EUT are recorded (ie: margin > 20 dB from the applicable limit) and considered that's already beyond the background noise floor.
 3. we have done x, y, z planes in EUT and horizontal and vertical polarization in detecting antenna.
 4. All of RB size has been tested for emissions and EIRP, with the 1RB configuration observed as the worst case
 5. We are performed 16QAM and QPSK modulations. The worst case data are reported in the table above.
 6. We were attached the results of standalone with wireless charging cover (close). Because the results of close condition is higher than open condition.

7.9.7 RADIATED SPURIOUS EMISSIONS (1.4 MHz Band 5 LTE)

- ▣ OPERATING FREQUENCY : 824.70 MHz
- ▣ MEASURED OUTPUT POWER: 17.59 dBm = 0.057 W
- ▣ MODULATION SIGNAL: 1.4 MHz QPSK
- ▣ DISTANCE: 3 meters
- ▣ LIMIT: $43 + 10 \log_{10} (W) =$ 30.59 dBc

Ch	Freq (MHz)	Measured Level (dBm)	Ant. Gain (dBd)	Substitute Level (dBm)	C.L	Pol	ERP (dBm)	dBc
20407 (824.7)	1,649.40	-54.91	9.71	-62.95	1.29	V	-54.53	72.12
	2,474.10	-55.69	10.54	-60.81	1.60	V	-51.87	69.46
	3,298.80	-56.73	12.23	-61.81	1.85	H	-51.43	69.02
20525 (836.5)	1,673.00	-52.40	9.78	-60.57	1.28	H	-52.07	69.66
	2,509.50	-57.28	10.65	-62.28	1.61	H	-53.24	70.83
	3,346.00	-56.65	12.41	-62.13	1.86	H	-51.58	69.17
20643 (848.3)	1,696.60	-51.09	9.84	-59.31	1.30	V	-50.77	68.36
	2,544.90	-57.14	10.72	-62.03	1.63	H	-52.94	70.53
	3,393.20	-55.75	12.40	-61.04	1.87	H	-50.51	68.10

- NOTES:**
1. Radiated Spurious Emission Measurements at 3 meters by Substitution Method according to ANSI/TIA/EIA-603-D-2010 June 24, 2010:
 2. We are performed all frequency to 10th harmonics from 30 MHz. Measurements above show only up to 3 maximum emissions noted, or would be lesser if no specific emissions from the EUT are recorded (ie: margin > 20 dB from the applicable limit) and considered that's already beyond the background noise floor.
 3. we have done x, y, z planes in EUT and horizontal and vertical polarization in detecting antenna.
 4. All of RB size has been tested for emissions and ERP, with the 1RB configuration observed as the worst case
 5. We are performed 16QAM and QPSK modulations. The worst case data are reported in the table above.
 6. We were attached the results of standalone with wireless charging cover (close). Because the results of close condition is higher than open condition.

7.9.8 RADIATED SPURIOUS EMISSIONS (3 MHz Band 5 LTE)

- OPERATING FREQUENCY : 825.50 MHz
- MEASURED OUTPUT POWER: 17.69 dBm = 0.059 W
- MODULATION SIGNAL: 3 MHz QPSK
- DISTANCE: 3 meters
- LIMIT: $43 + 10 \log_{10}(W) =$ 30.69 dBc

Ch	Freq (MHz)	Measured Level (dBm)	Ant. Gain (dBd)	Substitute Level (dBm)	C.L	Pol	ERP (dBm)	dBc
20415 (825.5)	1,651.00	-55.05	9.71	-63.09	1.29	V	-54.67	72.36
	2,476.50	-56.84	10.54	-61.91	1.61	V	-52.98	70.67
	3,302.00	-55.93	12.25	-61.06	1.85	V	-50.66	68.35
20525 (836.5)	1,673.00	-52.85	9.78	-61.02	1.28	H	-52.52	70.21
	2,509.50	-56.71	10.65	-61.71	1.61	H	-52.67	70.36
	3,346.00	-56.98	12.41	-62.46	1.86	V	-51.91	69.60
20635 (847.5)	1,695.00	-52.18	9.84	-60.42	1.30	H	-51.88	69.57
	2,542.50	-56.39	10.72	-61.25	1.63	V	-52.16	69.85
	3,390.00	-56.03	12.40	-61.26	1.84	V	-50.70	68.39

- NOTES:**
1. Radiated Spurious Emission Measurements at 3 meters by Substitution Method according to ANSI/TIA/EIA-603-D-2010 June 24, 2010:
 2. We are performed all frequency to 10th harmonics from 30 MHz. Measurements above show only up to 3 maximum emissions noted, or would be lesser if no specific emissions from the EUT are recorded (ie: margin > 20 dB from the applicable limit) and considered that's already beyond the background noise floor.
 3. we have done x, y, z planes in EUT and horizontal and vertical polarization in detecting antenna.
 4. All of RB size has been tested for emissions and ERP, with the 1RB configuration observed as the worst case
 5. We are performed 16QAM and QPSK modulations. The worst case data are reported in the table above.
 6. We were attached the results of standalone with wireless charging cover (close). Because the results of close condition is higher than open condition.

7.9.9 RADIATED SPURIOUS EMISSIONS (5 MHz Band 5 LTE)

- OPERATING FREQUENCY : 826.50 MHz
- MEASURED OUTPUT POWER: 17.77 dBm = 0.060 W
- MODULATION SIGNAL: 5 MHz QPSK
- DISTANCE: 3 meters
- LIMIT: $43 + 10 \log_{10}(W) =$ 30.77 dBc

Ch	Freq (MHz)	Measured Level (dBm)	Ant. Gain (dBd)	Substitute Level (dBm)	C.L	Pol	ERP (dBm)	dBc
20425 (826.5)	1,653.00	-54.85	9.72	-62.90	1.29	V	-54.47	72.24
	2,479.50	-56.79	10.54	-61.81	1.61	V	-52.88	70.65
	3,306.00	-56.27	12.26	-61.46	1.86	H	-51.06	68.83
20525 (836.5)	1,673.00	-51.43	9.78	-59.60	1.28	V	-51.10	68.87
	2,509.50	-56.59	10.65	-61.59	1.61	V	-52.55	70.32
	3,346.00	-56.27	12.41	-61.75	1.86	V	-51.20	68.97
20625 (846.5)	1,693.00	-49.97	9.83	-58.22	1.30	H	-49.69	67.46
	2,539.50	-56.02	10.71	-60.84	1.63	V	-51.76	69.53
	3,386.00	-55.72	12.40	-61.11	1.84	H	-50.55	68.32

- NOTES:**
1. Radiated Spurious Emission Measurements at 3 meters by Substitution Method according to ANSI/TIA/EIA-603-D-2010 June 24, 2010:
 2. We are performed all frequency to 10th harmonics from 30 MHz. Measurements above show only up to 3 maximum emissions noted, or would be lesser if no specific emissions from the EUT are recorded (ie: margin > 20 dB from the applicable limit) and considered that's already beyond the background noise floor.
 3. we have done x, y, z planes in EUT and horizontal and vertical polarization in detecting antenna.
 4. All of RB size has been tested for emissions and ERP, with the 1RB configuration observed as the worst case
 5. We are performed 16QAM and QPSK modulations. The worst case data are reported in the table above.
 6. We were attached the results of standalone with wireless charging cover (close). Because the results of close condition is higher than open condition.

7.9.10 RADIATED SPURIOUS EMISSIONS (10 MHz Band 5 LTE)

- OPERATING FREQUENCY : 836.50 MHz
- MEASURED OUTPUT POWER: 17.54 dBm = 0.057 W
- MODULATION SIGNAL: 10 MHz QPSK
- DISTANCE: 3 meters
- LIMIT: $43 + 10 \log_{10} (W) =$ 30.54 dBc

Ch	Freq (MHz)	Measured Level (dBm)	Ant. Gain (dBd)	Substitute Level (dBm)	C.L	Pol	ERP (dBm)	dBc
20450 (829.0)	1,658.00	-55.73	9.73	-63.80	1.28	V	-55.35	72.89
	2,487.00	-55.25	10.54	-60.23	1.62	H	-51.31	68.85
	3,316.00	-55.91	12.30	-61.22	1.89	V	-50.81	68.35
20525 (836.5)	1,673.00	-50.05	9.78	-58.22	1.28	V	-49.72	67.26
	2,509.50	-56.71	10.65	-61.71	1.61	H	-52.67	70.21
	3,346.00	-56.89	12.41	-62.37	1.86	H	-51.82	69.36
20600 (844.0)	1,688.00	-53.40	9.81	-61.64	1.30	V	-53.13	70.67
	2,532.00	-57.11	10.69	-61.88	1.62	H	-52.81	70.35
	3,376.00	-56.46	12.41	-61.99	1.85	V	-51.43	68.97

- NOTES:**
1. Radiated Spurious Emission Measurements at 3 meters by Substitution Method according to ANSI/TIA/EIA-603-D-2010 June 24, 2010:
 2. We are performed all frequency to 10th harmonics from 30 MHz. Measurements above show only up to 3 maximum emissions noted, or would be lesser if no specific emissions from the EUT are recorded (ie: margin > 20 dB from the applicable limit) and considered that's already beyond the background noise floor.
 3. we have done x, y, z planes in EUT and horizontal and vertical polarization in detecting antenna.
 4. All of RB size has been tested for emissions and ERP, with the 1RB configuration observed as the worst case
 5. We are performed 16QAM and QPSK modulations. The worst case data are reported in the table above.
 6. We were attached the results of standalone with wireless charging cover (close). Because the results of close condition is higher than open condition.

7.10 PEAK-TO-AVERAGE RATIO

Band	Band Width	Frequency (MHz)	Modulation	Resource Block Size	Resource Block Offset	Data (dB)
Band 2	1.4 MHz	1880.0	QPSK	6	0	5.05
			16-QAM	6	0	5.90
	3 MHz		QPSK	15	0	5.12
			16-QAM	15	0	5.91
	5 MHz		QPSK	25	0	5.08
			16-QAM	25	0	5.88
	10 MHz		QPSK	50	0	5.13
			16-QAM	50	0	5.89
	15 MHz		QPSK	75	0	4.94
			16-QAM	75	0	5.75
	20 MHz		QPSK	100	0	4.97
			16-QAM	100	0	5.78

Band	Band Width	Frequency (MHz)	Modulation	Resource Block Size	Resource Block Offset	Data (dB)
Band 5	1.4 MHz	836.5	QPSK	6	0	4.12
			16-QAM	6	0	4.88
	3 MHz		QPSK	15	0	4.49
			16-QAM	15	0	5.32
	5 MHz		QPSK	25	0	4.39
			16-QAM	25	0	5.14
	10 MHz		QPSK	50	0	4.61
			16-QAM	50	0	5.37

- Plots of the EUT's Peak- to- Average Ratio are shown Page 97 ~ 106.

7.11 OCCUPIED BANDWIDTH

Band	Band Width	Frequency (MHz)	Modulation	Resource Block Size	Resource Block Offset	Data (MHz)
Band 2	1.4 MHz	1880.0	QPSK	6	0	1.0887
			16-QAM	6	0	1.0923
	3 MHz		QPSK	15	0	2.6979
			16-QAM	15	0	2.7012
	5 MHz		QPSK	25	0	4.4919
			16-QAM	25	0	4.5012
	10 MHz		QPSK	50	0	8.9848
			16-QAM	50	0	8.9604
	15 MHz		QPSK	75	0	13.4860
			16-QAM	75	0	13.4700
	20 MHz		QPSK	100	0	17.9720
			16-QAM	100	0	17.9740

Band	Band Width	Frequency (MHz)	Modulation	Resource Block Size	Resource Block Offset	Data (MHz)
Band 5	1.4 MHz	836.5	QPSK	6	0	1.0935
			16-QAM	6	0	1.0970
	3 MHz		QPSK	15	0	2.7078
			16-QAM	15	0	2.7031
	5 MHz		QPSK	25	0	4.5123
			16-QAM	25	0	4.5068
	10 MHz		QPSK	50	0	8.9850
			16-QAM	50	0	8.9482

- Plots of the EUT's Occupied Bandwidth are shown Page 87 ~ 96.

7.12 CONDUCTED SPURIOUS EMISSIONS

Band	Band Width (MHz)	Frequency (MHz)	Modulation	Resource Block Size	Resource Block Offset	Frequency of Maximum Harmonic (GHz)	Maximum Data [dBm]
Band 2	1.4	1850.7	QPSK	1	0	3.7005	-27.95
		1880.0	QPSK	1	0	3.7593	-27.05
		1909.3	QPSK	1	0	16.7825	-28.44
	3	1851.5	QPSK	1	0	3.7005	-25.86
		1880.0	QPSK	1	0	19.0350	-28.40
		1908.5	QPSK	1	0	16.9705	-27.35
	5	1852.5	QPSK	1	0	3.7010	-26.70
		1880.0	QPSK	1	0	16.4665	-28.06
		1907.5	QPSK	1	0	17.0390	-27.31
	10	1855.0	QPSK	1	0	3.7015	-25.33
		1880.0	QPSK	1	0	16.7720	-28.31
		1905.0	QPSK	1	0	16.5800	-27.94
	15	1857.5	QPSK	1	0	3.7020	-26.81
		1880.0	QPSK	1	0	3.7468	-25.20
		1902.5	QPSK	1	0	16.8505	-28.24
	20	1860.0	QPSK	1	0	3.7024	-25.03
		1880.0	QPSK	1	0	19.0730	-26.94
		1900.0	QPSK	1	0	16.8085	-28.31

Band	Band Width (MHz)	Frequency (MHz)	Modulation	Resource Block Size	Resource Block Offset	Frequency of Maximum Harmonic (GHz)	Maximum Data [dBm]
Band 5	1.4	824.7	QPSK	1	0	3.161100	-31.86
		836.5		1	0	3.292805	-32.44
		848.3		1	0	5.811000	-31.93
	3	825.5		1	0	3.191417	-32.03
		836.5		1	0	3.098478	-32.41
		847.5		1	0	3.149172	-32.76
	5	826.5		1	0	5.644500	-32.35
		836.5		1	0	2.399199	-32.39
		846.5		1	0	3.111400	-31.94
	10	829.0		1	0	2.691435	-31.92
		836.5		1	0	2.144735	-32.26
		844.0		1	0	5.785500	-31.98

- Plots of the EUT's Conducted Spurious Emissions are shown Page 137~ 166.

7.12.1 BAND EDGE

- Plots of the EUT's Band Edge are shown Page 107 ~ 136

7.13 FREQUENCY STABILITY / VARIATION OF AMBIENT TEMPERATURE

7.13.1 FREQUENCY STABILITY (1.4 MHz Band 2 LTE)

- ▣ OPERATING FREQUENCY: 1880,000,000 Hz
- ▣ CHANNEL: 18900 (1.4 MHz)
- ▣ REFERENCE VOLTAGE: 3.85 VDC
- ▣ DEVIATION LIMIT: -

Voltage (%)	Power (VDC)	Temp. (°C)	Frequency (Hz)	Frequency Error (Hz)	Deviation (%)	ppm
100%	3.85	+20(Ref)	1880 000 007	0	0.000 000	0.000
100%		-30	1880 000 004	-2.80	0.000 000	-0.001
100%		-20	1880 000 000	-7.20	0.000 000	-0.004
100%		-10	1880 000 002	-5.00	0.000 000	-0.003
100%		0	1880 000 003	-3.90	0.000 000	-0.002
100%		+10	1880 000 002	-5.20	0.000 000	-0.003
100%		+30	1880 000 001	-6.70	0.000 000	-0.004
100%		+40	1880 000 013	6.00	0.000 000	0.003
100%		+50	1880 000 001	-6.50	0.000 000	-0.003
Batt. Endpoint		3.27	+20	1880 000 003	-3.80	0.000 000

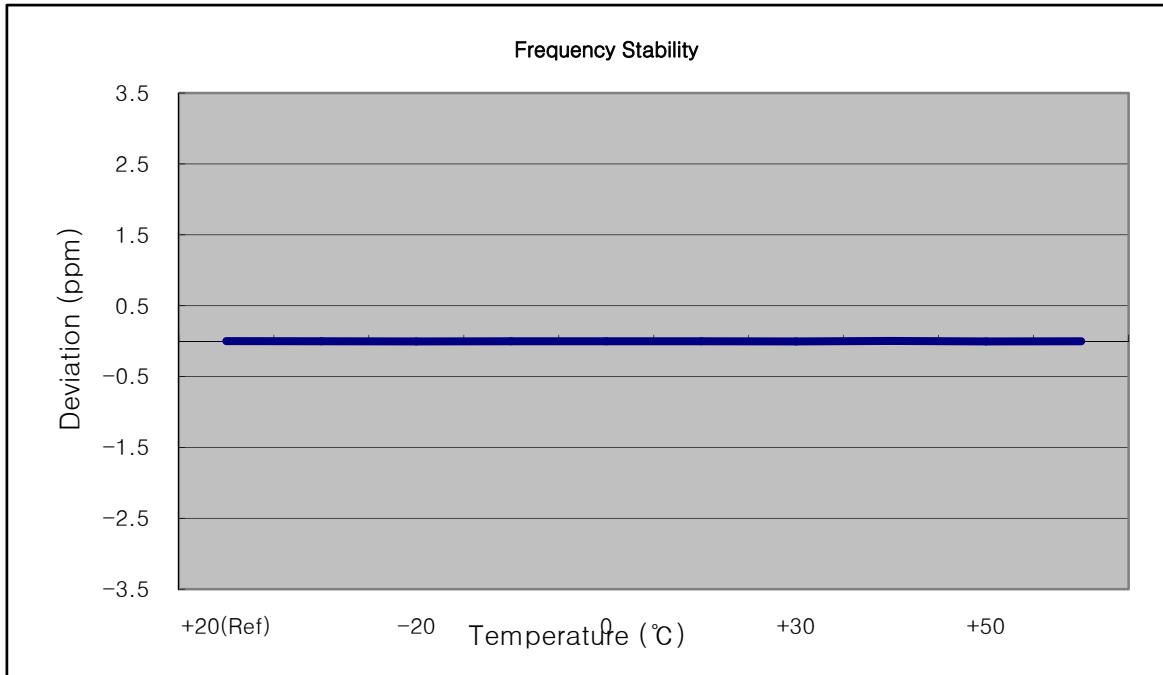

7.13.2 FREQUENCY STABILITY (3 MHz Band 2 LTE)

- ▣ OPERATING FREQUENCY: 1880,000,000 Hz
- ▣ CHANNEL: 18900 (3 MHz)
- ▣ REFERENCE VOLTAGE: 3.85 VDC
- ▣ DEVIATION LIMIT: -

Voltage (%)	Power (VDC)	Temp. (°C)	Frequency (Hz)	Frequency Error (Hz)	Deviation (%)	ppm
100%	3.85	+20(Ref)	1880 000 009	0	0.000 000	0.000
100%		-30	1880 000 002	-7.00	0.000 000	-0.004
100%		-20	1880 000 014	4.80	0.000 000	0.003
100%		-10	1880 000 002	-6.90	0.000 000	-0.004
100%		0	1880 000 005	-3.70	0.000 000	-0.002
100%		+10	1880 000 002	-7.10	0.000 000	-0.004
100%		+30	1880 000 003	-6.00	0.000 000	-0.003
100%		+40	1880 000 003	-6.60	0.000 000	-0.004
100%		+50	1880 000 001	-7.70	0.000 000	-0.004
Batt. Endpoint	3.27	+20	1880 000 018	9.00	0.000 000	0.005

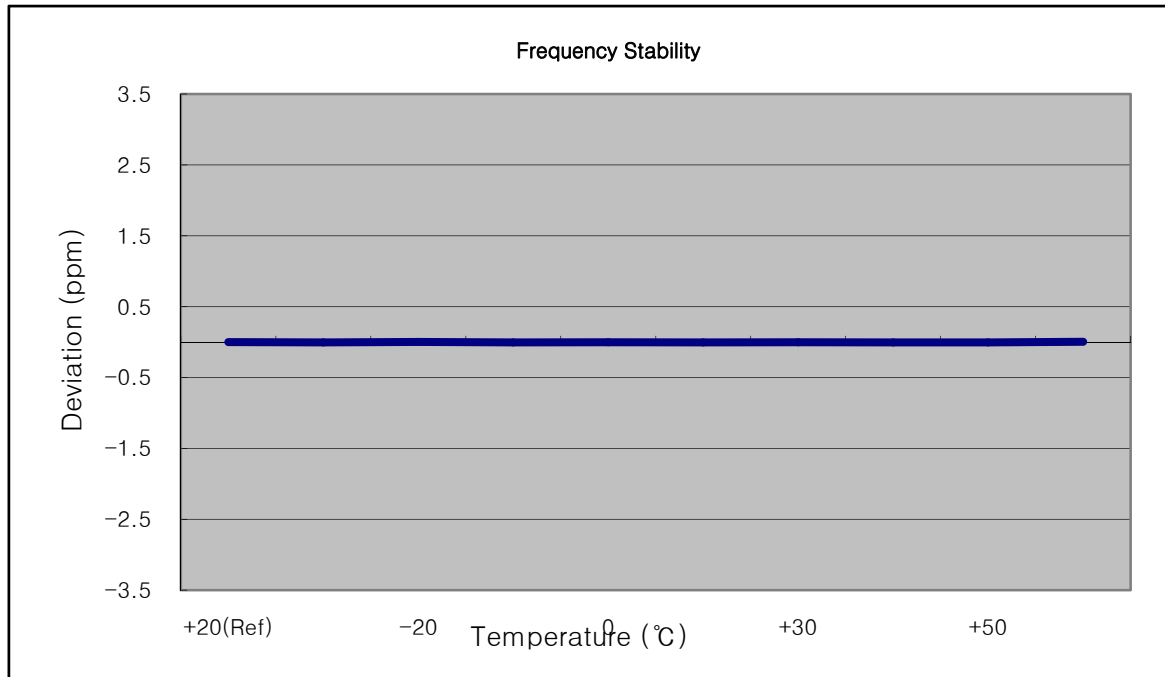

7.13.3 FREQUENCY STABILITY (5 MHz Band 2 LTE)

- ▣ OPERATING FREQUENCY: 1880,000,000 Hz
- ▣ CHANNEL: 18900 (5 MHz)
- ▣ REFERENCE VOLTAGE: 3.85 VDC
- ▣ DEVIATION LIMIT: -

Voltage (%)	Power (VDC)	Temp. (°C)	Frequency (Hz)	Frequency Error (Hz)	Deviation (%)	ppm
100%	3.85	+20(Ref)	1880 000 004	0	0.000 000	0.000
100%		-30	1879 999 997	-6.70	0.000 000	-0.004
100%		-20	1879 999 996	-7.90	0.000 000	-0.004
100%		-10	1879 999 999	-5.60	0.000 000	-0.003
100%		0	1880 000 000	-4.50	0.000 000	-0.002
100%		+10	1879 999 998	-5.80	0.000 000	-0.003
100%		+30	1879 999 999	-5.60	0.000 000	-0.003
100%		+40	1880 000 000	-3.80	0.000 000	-0.002
100%		+50	1879 999 999	-5.60	0.000 000	-0.003
Batt. Endpoint	3.27	+20	1879 999 999	-4.90	0.000 000	-0.003

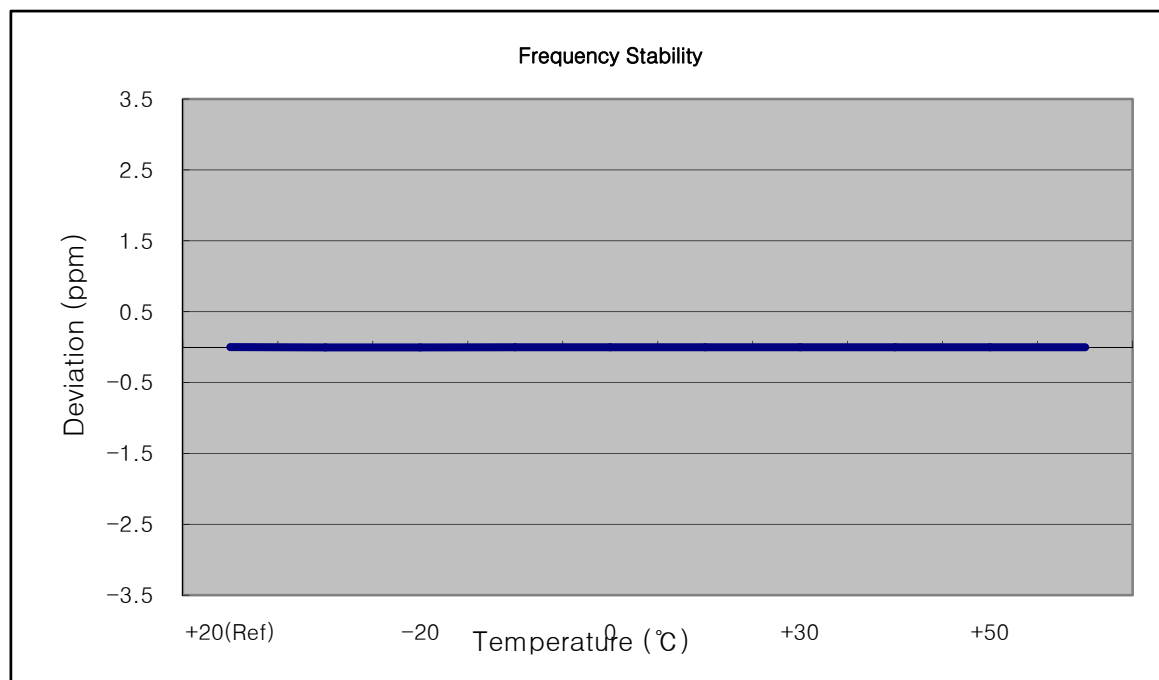

7.13.4 FREQUENCY STABILITY (10 MHz Band 2 LTE)

- ▣ OPERATING FREQUENCY: 1880,000,000 Hz
- ▣ CHANNEL: 18900 (10 MHz)
- ▣ REFERENCE VOLTAGE: 3.85 VDC
- ▣ DEVIATION LIMIT: -

Voltage (%)	Power (VDC)	Temp. (°C)	Frequency (Hz)	Frequency Error (Hz)	Deviation (%)	ppm
100%	3.85	+20(Ref)	1880 000 005	0	0.000 000	0.000
100%		-30	1880 000 003	-2.50	0.000 000	-0.001
100%		-20	1880 000 001	-4.10	0.000 000	-0.002
100%		-10	1879 999 998	-7.20	0.000 000	-0.004
100%		0	1879 999 997	-8.20	0.000 000	-0.004
100%		+10	1880 000 001	-4.90	0.000 000	-0.003
100%		+30	1880 000 000	-5.50	0.000 000	-0.003
100%		+40	1880 000 013	7.40	0.000 000	0.004
100%		+50	1880 000 001	-4.90	0.000 000	-0.003
Batt. Endpoint		3.27	+20	1879 999 999	-6.10	0.000 000

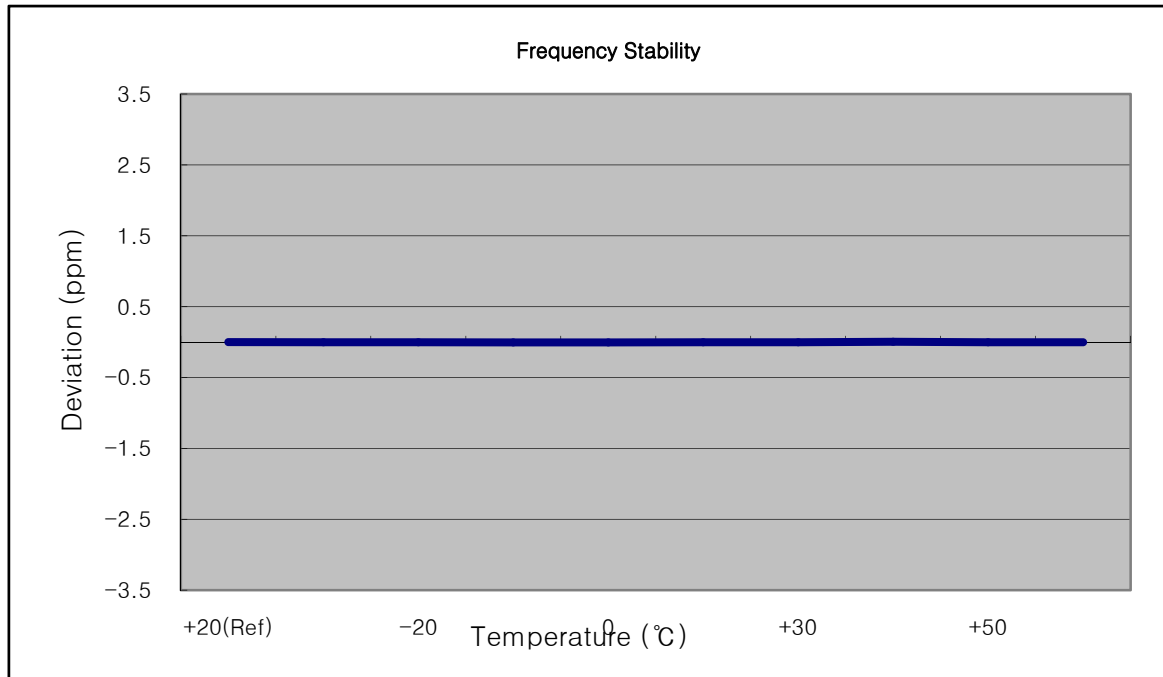

7.13.5 FREQUENCY STABILITY (15 MHz Band 2 LTE)

- ▣ OPERATING FREQUENCY: 1880,000,000 Hz
- ▣ CHANNEL: 18900 (15 MHz)
- ▣ REFERENCE VOLTAGE: 3.85 VDC
- ▣ DEVIATION LIMIT: -

Voltage (%)	Power (VDC)	Temp. (°C)	Frequency (Hz)	Frequency Error (Hz)	Deviation (%)	ppm
100%	3.85	+20(Ref)	1880 000 004	0	0.000 000	0.000
100%		-30	1879 999 996	-8.30	0.000 000	-0.004
100%		-20	1880 000 000	-4.60	0.000 000	-0.002
100%		-10	1879 999 998	-5.70	0.000 000	-0.003
100%		0	1880 000 010	5.60	0.000 000	0.003
100%		+10	1880 000 000	-4.30	0.000 000	-0.002
100%		+30	1880 000 007	3.30	0.000 000	0.002
100%		+40	1879 999 999	-4.70	0.000 000	-0.002
100%		+50	1880 000 009	4.60	0.000 000	0.002
Batt. Endpoint	3.27	+20	1879 999 997	-6.70	0.000 000	-0.004

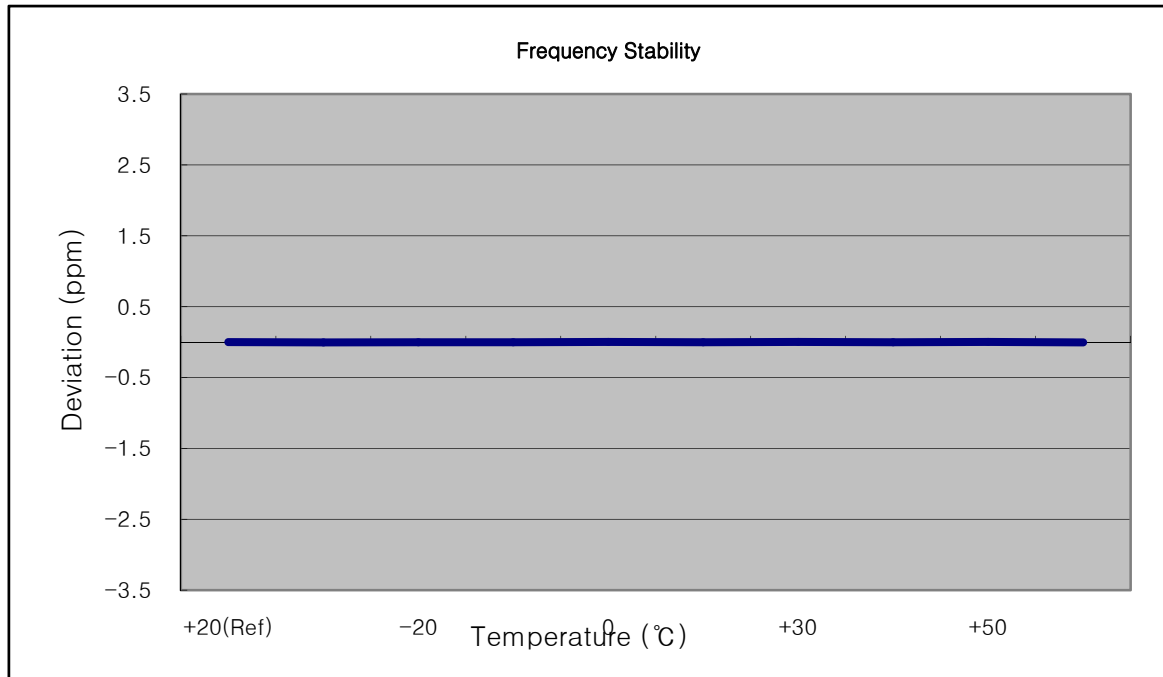

7.13.6 FREQUENCY STABILITY (20 MHz Band 2 LTE)

- ▣ OPERATING FREQUENCY: 1880,000,000 Hz
- ▣ CHANNEL: 18900 (20 MHz)
- ▣ REFERENCE VOLTAGE: 3.85 VDC
- ▣ DEVIATION LIMIT: -

Voltage (%)	Power (VDC)	Temp. (°C)	Frequency (Hz)	Frequency Error (Hz)	Deviation (%)	ppm
100%	3.85	+20(Ref)	1879 999 995	0	0.000 000	0.000
100%		-30	1879 999 992	-3.50	0.000 000	-0.002
100%		-20	1879 999 991	-4.40	0.000 000	-0.002
100%		-10	1879 999 988	-6.80	0.000 000	-0.004
100%		0	1879 999 990	-5.40	0.000 000	-0.003
100%		+10	1879 999 990	-5.60	0.000 000	-0.003
100%		+30	1879 999 991	-4.40	0.000 000	-0.002
100%		+40	1879 999 990	-5.30	0.000 000	-0.003
100%		+50	1879 999 989	-6.00	0.000 000	-0.003
Batt. Endpoint	3.27	+20	1879 999 987	-8.00	0.000 000	-0.004

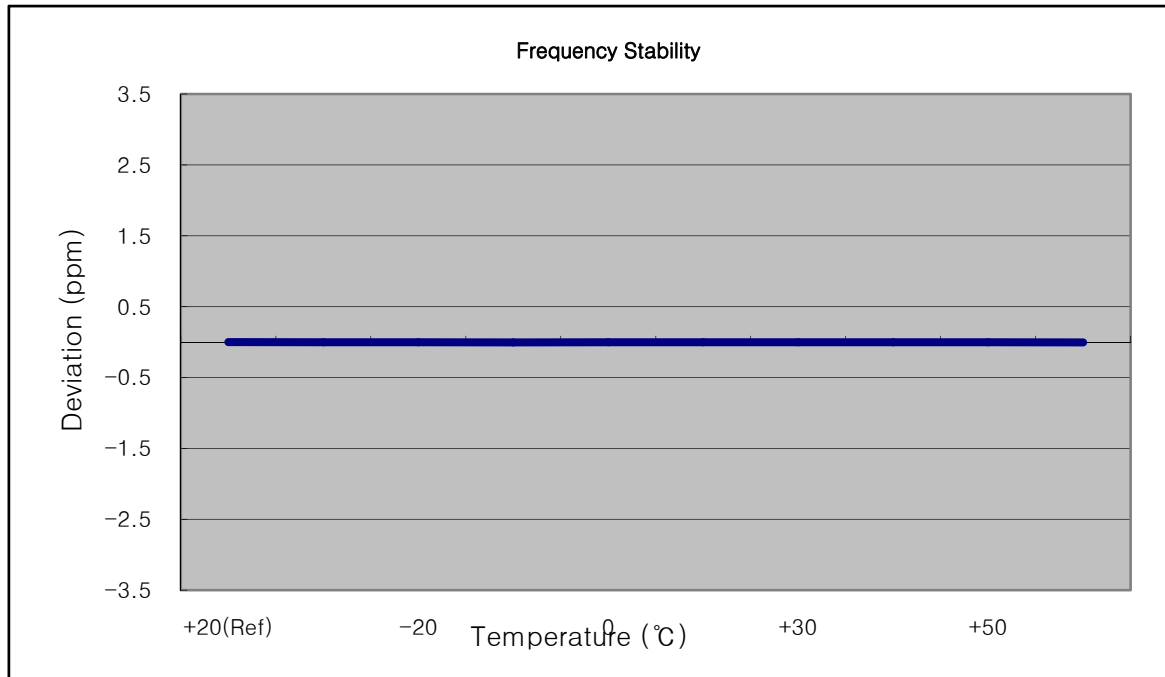

7.13.7 FREQUENCY STABILITY (1.4 MHz Band 5 LTE)

- ▣ OPERATING FREQUENCY: 836,500,000 Hz
- ▣ CHANNEL: 20525 (1.4 MHz)
- ▣ REFERENCE VOLTAGE: 3.85 VDC
- ▣ DEVIATION LIMIT: ± 0.000 25 % or 2.5 ppm

Voltage (%)	Power (VDC)	Temp. (°C)	Frequency (Hz)	Frequency Error (Hz)	Deviation (%)	ppm
100%	3.85	+20(Ref)	836 499 996	0	0.000 000	0.000
100%		-30	836 500 003	6.40	0.000 001	0.008
100%		-20	836 500 001	4.40	0.000 001	0.005
100%		-10	836 500 000	4.20	0.000 001	0.005
100%		0	836 499 999	2.50	0.000 000	0.003
100%		+10	836 499 998	1.50	0.000 000	0.002
100%		+30	836 499 999	2.60	0.000 000	0.003
100%		+40	836 500 003	6.60	0.000 001	0.008
100%		+50	836 499 998	2.20	0.000 000	0.003
Batt. Endpoint	3.27	+20	836 500 000	3.30	0.000 000	0.004

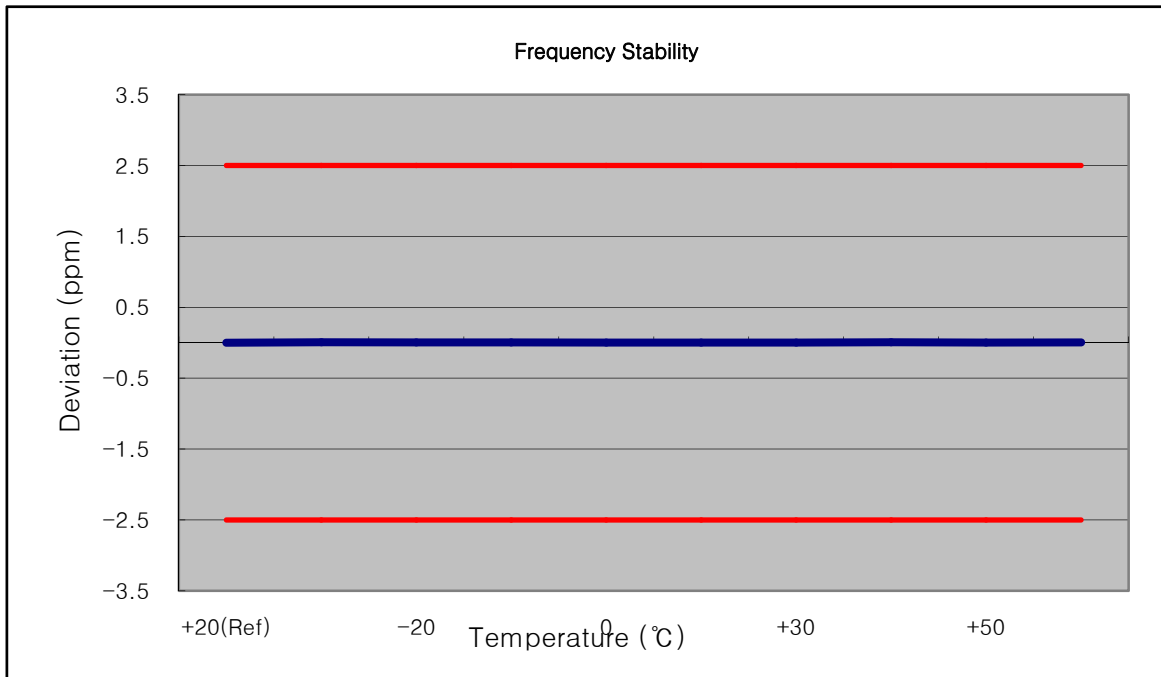

7.13.8 FREQUENCY STABILITY (3 MHz Band 5 LTE)

- ▣ OPERATING FREQUENCY: 836,500,000 Hz
- ▣ CHANNEL: 20525 (3 MHz)
- ▣ REFERENCE VOLTAGE: 3.85 VDC
- ▣ DEVIATION LIMIT: ± 0.000 25 % or 2.5 ppm

Voltage (%)	Power (VDC)	Temp. (°C)	Frequency (Hz)	Frequency Error (Hz)	Deviation (%)	ppm
100%	3.85	+20(Ref)	836 499 996	0	0.000 000	0.000
100%		-30	836 500 000	4.00	0.000 000	0.005
100%		-20	836 500 001	5.60	0.000 001	0.007
100%		-10	836 500 000	4.50	0.000 001	0.005
100%		0	836 500 000	3.80	0.000 000	0.005
100%		+10	836 500 002	6.00	0.000 001	0.007
100%		+30	836 500 000	3.70	0.000 000	0.004
100%		+40	836 499 994	-2.30	0.000 000	-0.003
100%		+50	836 499 999	3.40	0.000 000	0.004
Batt. Endpoint	3.27	+20	836 500 001	5.60	0.000 001	0.007

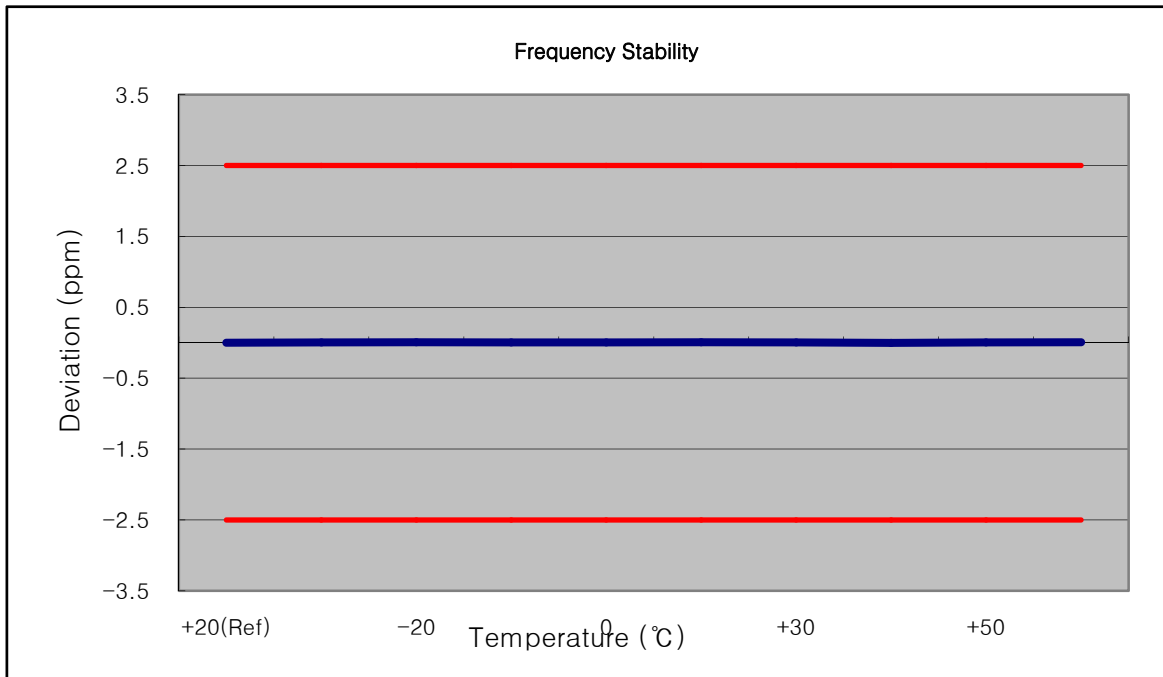

7.13.9 FREQUENCY STABILITY (5 MHz Band 5 LTE)

- ▣ OPERATING FREQUENCY: 836,500,000 Hz
- ▣ CHANNEL: 20525 (5 MHz)
- ▣ REFERENCE VOLTAGE: 3.85 VDC
- ▣ DEVIATION LIMIT: ± 0.000 25 % or 2.5 ppm

Voltage (%)	Power (VDC)	Temp. (°C)	Frequency (Hz)	Frequency Error (Hz)	Deviation (%)	ppm
100%	3.85	+20(Ref)	836 499 996	0	0.000 000	0.000
100%		-30	836 500 001	5.50	0.000 001	0.007
100%		-20	836 499 999	3.60	0.000 000	0.004
100%		-10	836 500 003	7.40	0.000 001	0.009
100%		0	836 499 999	3.40	0.000 000	0.004
100%		+10	836 500 000	4.60	0.000 001	0.005
100%		+30	836 500 001	4.90	0.000 001	0.006
100%		+40	836 500 000	4.20	0.000 001	0.005
100%		+50	836 499 999	3.60	0.000 000	0.004
Batt. Endpoint	3.27	+20	836 500 001	5.10	0.000 001	0.006

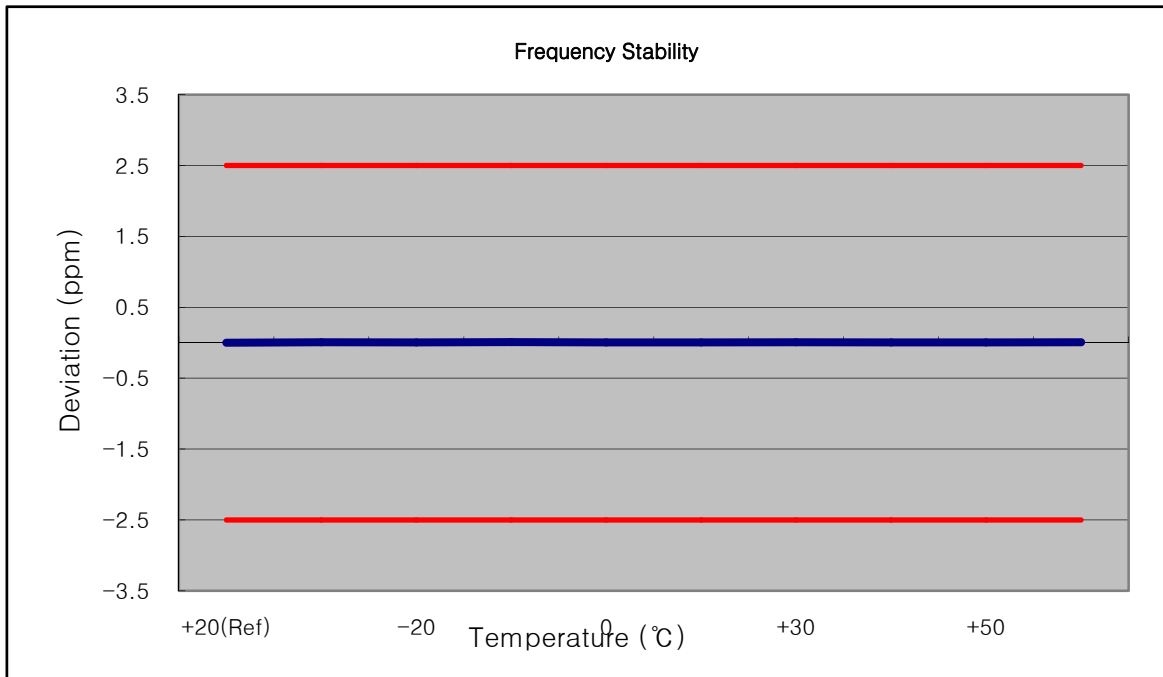

7.13.10 FREQUENCY STABILITY (10 MHz Band 5 LTE)

- OPERATING FREQUENCY: 836,500,000 Hz
- CHANNEL: 20525 (10 MHz)
- REFERENCE VOLTAGE: 3.85 VDC
- DEVIATION LIMIT: ± 0.000 25 % or 2.5 ppm

Voltage (%)	Power (VDC)	Temp. (°C)	Frequency (Hz)	Frequency Error (Hz)	Deviation (%)	ppm
100%	3.85	+20(Ref)	836 499 997	0	0.000 000	0.000
100%		-30	836 500 003	6.20	0.000 001	0.007
100%		-20	836 499 994	-2.30	0.000 000	-0.003
100%		-10	836 500 000	3.60	0.000 000	0.004
100%		0	836 500 000	3.40	0.000 000	0.004
100%		+10	836 500 001	4.10	0.000 000	0.005
100%		+30	836 500 000	3.40	0.000 000	0.004
100%		+40	836 500 002	5.30	0.000 001	0.006
100%		+50	836 500 001	4.40	0.000 001	0.005
Batt. Endpoint	3.27	+20	836 500 001	4.20	0.000 001	0.005

