



SAR EVALUATION REPORT

Applicant Name:
 LG Electronics MobileComm U.S.A., Inc.
 1000 Sylvan Avenue
 Englewood Cliffs, NJ 07632
 United States

Date of Testing:
 03/17/15 - 04/20/15
Test Site/Location:
 PCTEST Lab, Columbia, MD, USA
Document Serial No.:
 0Y1503170617.ZNF

FCC ID: ZNFH636
APPLICANT: LG ELECTRONICS MOBILECOMM U.S.A., INC.

DUT Type: Portable Handset
Application Type: Certification
FCC Rule Part(s): CFR §2.1093
Model(s): H636, LGH636, LG-H636

Equipment Class	Band & Mode	Tx Frequency	SAR			
			1 gm Head (W/kg)	1 gm Body-Worn (W/kg)	1 gm Hotspot (W/kg)	10 gm Extremity (W/kg)
PCE	GSM/GPRS/EDGE 850	824.20 - 848.80 MHz	0.36	0.42	0.55	
PCE	GSM/GPRS/EDGE 1900	1850.20 - 1909.80 MHz	0.32	0.42	0.42	
PCE	UMTS 850	826.40 - 846.60 MHz	0.48	0.65	0.76	
PCE	UMTS 1750	1712.4 - 1752.5 MHz	0.63	0.72	0.80	
PCE	UMTS 1900	1852.4 - 1907.6 MHz	0.66	0.78	0.78	
PCE	LTE Band 12	699.7 - 715.3 MHz	0.38	0.76	0.76	
PCE	LTE Band 5 (Cell)	824.7 - 848.3 MHz	0.43	0.58	0.71	
PCE	LTE Band 4 (AWS)	1710.7 - 1754.3 MHz	0.59	0.86	0.86	
PCE	LTE Band 2 (PCS)	1850.7 - 1909.3 MHz	0.54	0.74	0.74	
PCE	LTE Band 7	2502.5 - 2567.5 MHz	0.12	0.42	0.42	
DTS	2.4 GHz WLAN	2412 - 2462 MHz	0.24	0.10	0.10	
DTS	Bluetooth LE	2402 - 2480 MHz	N/A			
Nil	U-NII-1	5180 - 5240 MHz	N/A			
Nil	U-NII-2A	5260 - 5320 MHz	0.29	< 0.1		0.24
Nil	U-NII-2C	5500 - 5700 MHz	0.30	0.11		0.29
Nil	U-NII-3	5745 - 5825 MHz	0.36	0.12	0.12	
DSS	Bluetooth	2402 - 2480 MHz		< 0.1		< 0.1
Simultaneous SAR per KDB 690783 D01v01r03:			1.02	0.98	0.98	0.29

This wireless portable device has been shown to be capable of compliance for localized specific absorption rate (SAR) for uncontrolled environment/general population exposure limits specified in ANSI/IEEE C95.1-1992 and has been tested in accordance with the measurement procedures specified in Section 1.8 of this report; for North American frequency bands only.

I attest to the accuracy of data. All measurements reported herein were performed by me or were made under my supervision and are correct to the best of my knowledge and belief. I assume full responsibility for the completeness of these measurements and vouch for the qualifications of all persons taking them. Test results reported herein relate only to the item(s) tested.

Randy Ortanez
 President





The SAR Tick is an initiative of the Mobile Manufacturers Forum (MMF). While a product may be considered eligible, use of the SAR Tick logo requires an agreement with the MMF. Further details can be obtained by emailing: sartick@mmfai.info.

FCC ID: ZNFH636	SAR EVALUATION REPORT		Reviewed by: Quality Manager
Document S/N: 0Y1503170617.ZNF	Test Dates: 03/17/15 - 04/20/15	DUT Type: Portable Handset	Page 1 of 77

T A B L E O F C O N T E N T S

1	DEVICE UNDER TEST	3
2	LTE INFORMATION	9
3	INTRODUCTION	10
4	DOSIMETRIC ASSESSMENT	11
5	DEFINITION OF REFERENCE POINTS	12
6	TEST CONFIGURATION POSITIONS FOR HANDSETS	13
7	RF EXPOSURE LIMITS	16
8	FCC MEASUREMENT PROCEDURES.....	17
9	RF CONDUCTED POWERS.....	23
10	SYSTEM VERIFICATION.....	51
11	SAR DATA SUMMARY	55
12	FCC MULTI-TX AND ANTENNA SAR CONSIDERATIONS.....	67
13	SAR MEASUREMENT VARIABILITY	71
14	EQUIPMENT LIST.....	72
15	MEASUREMENT UNCERTAINTIES	73
16	CONCLUSION.....	75
17	REFERENCES	76
APPENDIX A: SAR TEST PLOTS		
APPENDIX B: SAR DIPOLE VERIFICATION PLOTS		
APPENDIX C: PROBE AND DIPOLE CALIBRATION CERTIFICATES		
APPENDIX D: SAR TISSUE SPECIFICATIONS		
APPENDIX E: SAR SYSTEM VALIDATION		
APPENDIX F: DUT ANTENNA DIAGRAM AND SAR TEST SETUP PHOTOGRAPHS		

FCC ID: ZNFH636	 PCTEST <small>ENGINEERING LABORATORY, INC.</small>	SAR EVALUATION REPORT	 LG	Reviewed by: Quality Manager
Document S/N: 0Y1503170617.ZNF	Test Dates: 03/17/15 - 04/20/15	DUT Type: Portable Handset	Page 2 of 77	

1 DEVICE UNDER TEST



1.1 Device Overview

Band & Mode	Operating Modes	Tx Frequency
GSM/GPRS/EDGE 850	Voice/Data	824.20 - 848.80 MHz
GSM/GPRS/EDGE 1900	Voice/Data	1850.20 - 1909.80 MHz
UMTS 850	Voice/Data	826.40 - 846.60 MHz
UMTS 1750	Voice/Data	1712.4 - 1752.5 MHz
UMTS 1900	Voice/Data	1852.4 - 1907.6 MHz
LTE Band 12	Voice/Data	699.7 - 715.3 MHz
LTE Band 17	Voice/Data	706.5 - 713.5 MHz
LTE Band 5 (Cell)	Voice/Data	824.7 - 848.3 MHz
LTE Band 4 (AWS)	Voice/Data	1710.7 - 1754.3 MHz
LTE Band 2 (PCS)	Voice/Data	1850.7 - 1909.3 MHz
LTE Band 7	Voice/Data	2502.5 - 2567.5 MHz
2.4 GHz WLAN	Data	2412 - 2462 MHz
U-NII-1	Data	5180 - 5240 MHz
U-NII-2A	Data	5260 - 5320 MHz
U-NII-2C	Data	5500 - 5700 MHz
U-NII-3	Data	5745 - 5825 MHz
Bluetooth	Data	2402 - 2480 MHz
Bluetooth LE	Data	2402 - 2480 MHz
NFC	Data	13.56 MHz

1.2 Nominal and Maximum Output Power Specifications

This device operates using the following maximum and nominal output power specifications. SAR values were scaled to the maximum allowed power to determine compliance per KDB Publication 447498 D01v05.



Mode / Band		Voice (dBm)	Burst Average GMSK (dBm)					Burst Average 8-PSK (dBm)			
		1 TX Slot	1 TX Slot	2 TX Slots	3 TX Slots	4 TX Slots	1 TX Slot	2 TX Slots	3 TX Slots	4 TX Slots	
GSM/GPRS/EDGE 850	Maximum	33.7	33.7	29.7	27.7	26.7	26.7	26.7	24.7	23.7	
	Nominal	33.2	33.2	29.2	27.2	26.2	26.2	26.2	24.2	23.2	
GSM/GPRS/EDGE 1900	Maximum	31.2	31.2	28.2	27.2	25.2	25.7	25.7	25.2	24.2	
	Nominal	30.7	30.7	27.7	26.7	24.7	25.2	25.2	24.7	23.7	

FCC ID: ZNFH636	 SAR EVALUATION REPORT 		Reviewed by: Quality Manager
Document S/N: 0Y1503170617.ZNF	Test Dates: 03/17/15 - 04/20/15	DUT Type: Portable Handset	Page 3 of 77

Mode / Band		Modulated Average (dBm)			
		3GPP WCDMA Rel. 99	3GPP HSDPA Rel. 5	3GPP HSUPA Rel. 6	3GPP DC-HSDPA Rel. 8
UMTS Band 5 (850 MHz)	Maximum	24.7	24.7	24.7	24.7
	Nominal	24.2	24.2	24.2	24.2
UMTS Band 4 (1750 MHz)	Maximum	23.7	23.7	23.7	23.7
	Nominal	23.2	23.2	23.2	23.2
UMTS Band 2 (1900 MHz)	Maximum	24.7	24.7	24.7	24.7
	Nominal	24.2	24.2	24.2	24.2

Mode / Band		Modulated Average (dBm)
LTE Band 12	Maximum	24.7
	Nominal	24.2
LTE Band 17	Maximum	24.7
	Nominal	24.2
LTE Band 5 (Cell)	Maximum	24.2
	Nominal	23.7
LTE Band 4 (AWS)	Maximum	23.7
	Nominal	23.2
LTE Band 2 (PCS)	Maximum	23.7
	Nominal	23.2
LTE Band 7	Maximum	23.7
	Nominal	23.2

Mode / Band		Modulated Average (dBm)
IEEE 802.11b (2.4 GHz)	Maximum	16.0
	Nominal	15.0
IEEE 802.11g (2.4 GHz)	Maximum	15.0
	Nominal	14.0
IEEE 802.11n (2.4 GHz)	Maximum	15.0
	Nominal	14.0
IEEE 802.11a (5 GHz)	Maximum	15.0
	Nominal	14.0
IEEE 802.11n (5 GHz)	Maximum	15.0
	Nominal	14.0
Bluetooth	Maximum	10.0
	Nominal	9.0
Bluetooth LE	Maximum	1.0
	Nominal	0.0

FCC ID: ZNFH636	 SAR EVALUATION REPORT 		Reviewed by: Quality Manager
Document S/N: 0Y1503170617.ZNF	Test Dates: 03/17/15 - 04/20/15	DUT Type: Portable Handset	Page 4 of 77

1.3 DUT Antenna Locations

The overall dimensions of this device are > 9 x 5 cm. Since the diagonal dimension of this device is > 160 mm and <200 mm, it is considered a “phablet”. A diagram showing the location of the device antennas can be found in Appendix F. Exact antenna dimensions and separation distances are shown in the Technical Descriptions in the FCC Filing.



**Table 1-1
Sides for SAR Testing**

Mode	Back	Front	Top	Bottom	Right	Left
GPRS 850	Yes	Yes	No	Yes	Yes	No
GPRS 1900	Yes	Yes	No	Yes	No	Yes
UMTS 850	Yes	Yes	No	Yes	Yes	No
UMTS 1750	Yes	Yes	No	Yes	No	Yes
UMTS 1900	Yes	Yes	No	Yes	No	Yes
LTE Band 12	Yes	Yes	No	Yes	Yes	No
LTE Band 5 (Cell)	Yes	Yes	No	Yes	Yes	No
LTE Band 4 (AWS)	Yes	Yes	No	Yes	No	Yes
LTE Band 2 (PCS)	Yes	Yes	No	Yes	No	Yes
LTE Band 7	Yes	Yes	No	Yes	Yes	No
2.4 GHz WLAN	Yes	Yes	Yes	No	Yes	No
5 GHz WLAN	Yes	Yes	Yes	No	Yes	No
Bluetooth	Yes	Yes	Yes	No	Yes	No

Note: Particular DUT edges were not required to be evaluated for Wireless Router SAR or Extremity SAR if the edges were greater than 2.5 cm from the transmitting antenna according to FCC KDB Publication 941225 D06v02 guidance, page 2 and FCC KDB 648474 D04v01r01. The distances between the transmit antennas and the edges of the device are included in the filing.

1.4 Near Field Communications (NFC) Antenna

This DUT has NFC operations. The NFC antenna is integrated into the battery cover. All SAR tests were performed with the battery cover with NFC antenna already incorporated. A diagram showing the location of the NFC antenna can be found in Appendix F.

FCC ID: ZNFH636	 SAR EVALUATION REPORT 		Reviewed by: Quality Manager
Document S/N: 0Y1503170617.ZNF	Test Dates: 03/17/15 - 04/20/15	DUT Type: Portable Handset	Page 5 of 77

1.5 Simultaneous Transmission Capabilities

According to FCC KDB Publication 447498 D05v01, transmitters are considered to be transmitting simultaneously when there is overlapping transmission, with the exception of transmissions during network hand-offs with maximum hand-off duration less than 30 seconds. Possible transmission paths for the DUT are shown in Figure 1-1 and are color-coded to indicate communication modes which share the same path. Modes which share the same transmission path cannot transmit simultaneously with one another.





Figure 1-1
Simultaneous Transmission Paths

This device contains multiple transmitters that may operate simultaneously, and therefore requires a simultaneous transmission analysis according to FCC KDB Publication 447498 D01v05 3) procedures.

Table 1-2
Simultaneous Transmission Scenarios

No.	Capable Transmit Configuration	Head	Body-Worn Accessory	Wireless Router	Extremity	Notes
1	GSM voice + 2.4 GHz Wi-Fi	Yes	Yes	N/A	Yes	
2	GSM voice + 5 GHz Wi-Fi	Yes	Yes	N/A	Yes	
3	GSM voice + 2.4 GHz Bluetooth	N/A	Yes	N/A	Yes	
4	UMTS + 2.4 GHz Wi-Fi	Yes	Yes	Yes	Yes	
5	UMTS + 5 GHz Wi-Fi	Yes	Yes	Yes	Yes	
6	UMTS + 2.4 GHz Bluetooth	N/A	Yes	N/A	Yes	
7	LTE + 2.4 GHz Wi-Fi	Yes	Yes	Yes	Yes	
8	LTE + 5 GHz Wi-Fi	Yes	Yes	Yes	Yes	
9	LTE + 2.4 GHz Bluetooth	N/A	Yes	N/A	Yes	
10	GPRS/EDGE + 2.4 GHz Wi-Fi	Yes*	Yes*	Yes	Yes	*-Pre-installed VOIP applications are considered.
11	GPRS/EDGE + 5 GHz Wi-Fi	Yes*	Yes*	Yes	Yes	*-Pre-installed VOIP applications are considered.
12	GPRS/EDGE + 2.4 GHz Bluetooth	N/A	Yes*	N/A	Yes	*-Pre-installed VOIP applications are considered.

- 2.4 GHz WLAN, 5 GHz WLAN, and 2.4 GHz Bluetooth share the same antenna path and cannot transmit simultaneously.
- All licensed modes share the same antenna path and cannot transmit simultaneously.
- When the user utilizes multiple services in UMTS 3G mode it uses multi-Radio Access Bearer or multi-RAB. The power control is based on a physical control channel (Dedicated Physical Control Channel [DPCCH]) and power control will be adjusted to meet the needs of both services. Therefore, the UMTS+WLAN scenario also represents the UMTS Voice/DATA + WLAN Hotspot scenario.
- Per the manufacturer, WIFI Direct is expected to be used in conjunction with a held-to-ear or body-worn accessory voice call. Simultaneous transmission scenarios involving WIFI direct are specified in the above table.
- 5 GHz wireless router is only supported for U-NII-3 by S/W, therefore U-NII-1, U-NII-2A and U-NII-2C were not evaluated for wireless router conditions.
- This device supports VoLTE.

FCC ID: ZNFH636	 SAR EVALUATION REPORT 		Reviewed by: Quality Manager
Document S/N: 0Y1503170617.ZNF	Test Dates: 03/17/15 - 04/20/15	DUT Type: Portable Handset	Page 6 of 77

1.6 SAR Test Exclusions Applied

(A) WIFI/BT

Since Wireless Router operations are not allowed by the chipset firmware using U-NII-1, U-NII-2A & U-NII-2C WIFI, only 2.4 GHz and U-NII-3 WIFI Hotspot SAR tests and combinations are considered for SAR with respect to Wireless Router configurations according to FCC KDB 941225 D06v02.

Since U-NII-1 and U-NII-2A bands have the same maximum output power and the highest reported SAR for U-NII-2A is less than 1.2 W/kg, SAR is not required for U-NII-1 band according to FCC KDB 248227 D01v02.

Per FCC KDB 447498 D01v05, the 1g SAR exclusion threshold for distances <50mm is defined by the following equation:

$$\frac{\text{Max Power of Channel (mW)}}{\text{Test Separation Dist (mm)}} * \sqrt{\text{Frequency(GHz)}} \leq 3.0$$

Based on the maximum conducted power of Bluetooth LE (rounded to the nearest mW) and the antenna to user separation distance, body-worn Bluetooth LE SAR was not required; $[(1/10) * \sqrt{2.480}] = 0.2 < 3.0$. Per KDB Publication 447498 D01v05, the maximum power of the channel was rounded to the nearest mW before calculation.

Per FCC KDB 447498 D01v05, the 10g SAR exclusion threshold for distances <50mm is defined by the following equation:

$$\frac{\text{Max Power of Channel (mW)}}{\text{Test Separation Dist (mm)}} * \sqrt{\text{Frequency(GHz)}} \leq 7.5$$

Based on the maximum conducted power of Bluetooth LE (rounded to the nearest mW) and the antenna to user separation distance, extremity Bluetooth LE SAR was not required; $[(1/5) * \sqrt{2.480}] = 0.3 < 7.5$. Per KDB Publication 447498 D01v05, the maximum power of the channel was rounded to the nearest mW before calculation. Bluetooth 10g SAR measurement was additionally evaluated per manufacturer's request.



Per FCC KDB Publication 648474 D04v01r01, this device is considered a "phablet" since the diagonal dimension is greater than 160mm and less than 200mm. Extremity SAR tests are required when wireless router mode does not apply or if wireless router 1g SAR > 1.2 W/kg. Because wireless router operations are not supported for U-NII-2A and U-NII-2C WLAN, extremity SAR tests were performed. Extremity SAR was not evaluated for 2.4 GHz WLAN and U-NII-3 WLAN operations since wireless router 1g SAR was < 1.2 W/kg.

(B) Licensed Transmitter(s)

GSM/GPRS/EDGE DTM is not supported for US bands. Therefore, the GSM Voice modes in this report do not transmit simultaneously with GPRS/EDGE Data.

This device is only capable of QPSK HSUPA in the uplink. Therefore, no additional SAR tests are required beyond that described for devices with HSUPA in KDB 941225 D01v03.

This device additionally supports LTE B17. LTE Band 12 and LTE Band 17 share the same transmission path. LTE Band 17 was not evaluated for SAR since the supported frequency range falls within the LTE Band 12 supported frequency range and the Band 17 target power was the same as the Band 12 target power.

FCC ID: ZNFH636	 PCTEST ENGINEERING LABORATORY, INC.	SAR EVALUATION REPORT	 LG	Reviewed by: Quality Manager
Document S/N: 0Y1503170617.ZNF	Test Dates: 03/17/15 - 04/20/15	DUT Type: Portable Handset		Page 7 of 77

LTE SAR for the higher modulations and lower bandwidths were not tested since the maximum average output power of all required channels and configurations was not more than 0.5 dB higher than the highest bandwidth; and the reported LTE SAR for the highest bandwidth was less than 1.45 W/kg for all configurations according to FCC KDB 941225 D05v02r03.

Per FCC KDB Publication 648474 D04v01r01, this device is considered a "phablet" since the diagonal dimension is greater than 160mm and less than 200mm. Therefore, extremity SAR tests are required when wireless router mode does not apply or if wireless router 1g SAR > 1.2 W/kg. Extremity SAR was not evaluated for licensed technologies since wireless router 1g SAR was < 1.2 W/kg for these modes.

1.7 Power Reduction for SAR

There is no power reduction used for any band/mode implemented in this device for SAR purposes.



1.8 Guidance Applied

- IEEE 1528-2003
- FCC KDB Publication 941225 D01v03, D05v02r03, D06v02 (2G/3G/4G and Hotspot)
- FCC KDB Publication 248227 D01v02 (SAR Considerations for 802.11 Devices)
- FCC KDB Publication 447498 D01v05r02 (General SAR Guidance)
- FCC KDB Publication 865664 D01v01r03, D02v01r01 (SAR Measurements up to 6 GHz)
- FCC KDB Publication 648474 D03-D04 (Phablet Procedures)
- October 2013 TCB Workshop Notes (GPRS Testing Considerations)

1.9 Device Serial Numbers

Several samples with identical hardware were used to support SAR testing. The manufacturer has confirmed that the device(s) tested have the same physical, mechanical and thermal characteristics and are within operational tolerances expected for production units.



	Head Serial Number	Body-Worn Serial Number	Hotspot Serial Number	Extremity Serial Number
GSM/GPRS/EDGE 850	1TU8L	1TU8L	1TU8L	-
GSM/GPRS/EDGE 1900	1TU8L	1TU8L	1TU8L	-
UMTS 850	1TU8L	1TU8L	1TU8L	-
UMTS 1750	1TU8L	1TU8L	1TU8L	-
UMTS 1900	1TU8L	1TU8L	1TU8L	-
LTE Band 12	1TU8K	1TU8K	1TU8K	-
LTE Band 5 (Cell)	1TU8K	1TU8K	1TU8K	-
LTE Band 4 (AWS)	1TU8K	1TU8K	1TU8K	-
LTE Band 2 (PCS)	1TU8K	1TU8K	1TU8K	-
LTE Band 7	1TU8K	1TU8K	1TU8K	-
2.4 GHz WLAN	1TU8Q	1TU8Q	1TU8Q	-
5 GHz WLAN	1TU8Q	1TU8Q	1TU8Q	1TU8Q
Bluetooth	-	1MKUW	-	1MKUW

FCC ID: ZNFH636	 SAR EVALUATION REPORT 		Reviewed by: Quality Manager
Document S/N: 0Y1503170617.ZNF	Test Dates: 03/17/15 - 04/20/15	DUT Type: Portable Handset	Page 8 of 77

2

LTE INFORMATION

LTE Information			
FCC ID	ZNFH636		
Form Factor	Portable Handset		
Frequency Range of each LTE transmission band	LTE Band 12 (699.7 - 715.3 MHz)		
	LTE Band 17 (706.5 - 713.5 MHz)		
	LTE Band 5 (Cell) (824.7 - 848.3 MHz)		
	LTE Band 4 (AWS) (1710.7 - 1754.3 MHz)		
	LTE Band 2 (PCS) (1850.7 - 1909.3 MHz)		
	LTE Band 7 (2502.5 - 2567.5 MHz)		
Channel Bandwidths	LTE Band 12: 1.4 MHz, 3 MHz, 5 MHz, 10 MHz		
	LTE Band 17: 5 MHz, 10 MHz		
	LTE Band 5 (Cell): 1.4 MHz, 3 MHz, 5 MHz, 10 MHz		
	LTE Band 4 (AWS): 1.4 MHz, 3 MHz, 5 MHz, 10 MHz, 15 MHz, 20 MHz		
	LTE Band 2 (PCS): 1.4 MHz, 3 MHz, 5 MHz, 10 MHz, 15 MHz, 20 MHz		
Channel Numbers and Frequencies (MHz)	Low	Mid	High
	LTE Band 12: 1.4 MHz	699.7 (23017)	707.5 (23095)
LTE Band 12: 3 MHz	700.5 (23025)	707.5 (23095)	714.5 (23165)
LTE Band 12: 5 MHz	701.5 (23035)	707.5 (23095)	713.5 (23155)
LTE Band 12: 10 MHz	704 (23060)	707.5 (23095)	711 (23130)
LTE Band 17: 5 MHz	706.5 (23755)	710 (23790)	713.5 (23825)
LTE Band 17: 10 MHz	709 (23780)	710 (23790)	711 (23800)
LTE Band 5 (Cell): 1.4 MHz	824.7 (20407)	836.5 (20525)	848.3 (20643)
LTE Band 5 (Cell): 3 MHz	825.5 (20415)	836.5 (20525)	847.5 (20635)
LTE Band 5 (Cell): 5 MHz	826.5 (20425)	836.5 (20525)	846.5 (20625)
LTE Band 5 (Cell): 10 MHz	829 (20450)	836.5 (20525)	844 (20600)
LTE Band 4 (AWS): 1.4 MHz	1710.7 (19957)	1732.5 (20175)	1754.3 (20393)
LTE Band 4 (AWS): 3 MHz	1711.5 (19965)	1732.5 (20175)	1753.5 (20385)
LTE Band 4 (AWS): 5 MHz	1712.5 (19975)	1732.5 (20175)	1752.5 (20375)
LTE Band 4 (AWS): 10 MHz	1715 (20000)	1732.5 (20175)	1750 (20350)
LTE Band 4 (AWS): 15 MHz	1717.5 (20025)	1732.5 (20175)	1747.5 (20325)
LTE Band 4 (AWS): 20 MHz	1720 (20050)	1732.5 (20175)	1745 (20300)
LTE Band 2 (PCS): 1.4 MHz	1850.7 (18607)	1880 (18900)	1909.3 (19193)
LTE Band 2 (PCS): 3 MHz	1851.5 (18615)	1880 (18900)	1908.5 (19185)
LTE Band 2 (PCS): 5 MHz	1852.5 (18625)	1880 (18900)	1907.5 (19175)
LTE Band 2 (PCS): 10 MHz	1855 (18650)	1880 (18900)	1905 (19150)
LTE Band 2 (PCS): 15 MHz	1857.5 (18675)	1880 (18900)	1902.5 (19125)
LTE Band 2 (PCS): 20 MHz	1860 (18700)	1880 (18900)	1900 (19100)
LTE Band 7: 5 MHz	2502.5 (20775)	2535 (21100)	2567.5 (21425)
LTE Band 7: 10 MHz	2505 (20800)	2535 (21100)	2565 (21400)
LTE Band 7: 15 MHz	2507.5 (20825)	2535 (21100)	2562.5 (21375)
LTE Band 7: 20 MHz	2510 (20850)	2535 (21100)	2560 (21350)
UE Category	4		
Modulations Supported in UL	QPSK, 16QAM		
LTE MPR Permanently implemented per 3GPP TS 36.101 section 6.2.3-6.2.5? (manufacturer attestation to be provided)	YES		
A-MPR (Additional MPR) disabled for SAR Testing?	YES		
LTE Release 10 Additional Information	This device does not support full LTE Release 10 features such as: Carrier Aggregation, Relay, HetNet, Enhanced MIMO, eICI, WIFI Offloading, MDH, eMBMA, Cross-Carrier Scheduling, Enhanced SC-FDMA.		

FCC ID: ZNFH636	 PCTEST ENGINEERING LABORATORY, INC.	SAR EVALUATION REPORT	 LG	Reviewed by: Quality Manager
Document S/N: 0Y1503170617.ZNF	Test Dates: 03/17/15 - 04/20/15	DUT Type: Portable Handset	Page 9 of 77	

3 INTRODUCTION

The FCC and Industry Canada have adopted the guidelines for evaluating the environmental effects of radio frequency (RF) radiation in ET Docket 93-62 on Aug. 6, 1996 and Health Canada Safety Code 6 to protect the public and workers from the potential hazards of RF emissions due to FCC-regulated portable devices. [1]

The safety limits used for the environmental evaluation measurements are based on the criteria published by the American National Standards Institute (ANSI) for localized specific absorption rate (SAR) in IEEE/ANSI C95.1-1992 Standard for Safety Levels with Respect to Human Exposure to Radio Frequency Electromagnetic Fields, 3 kHz to 300 GHz [3] and Health Canada RF Exposure Guidelines Safety Code 6 [22]. The measurement procedure described in IEEE/ANSI C95.3-2002 Recommended Practice for the Measurement of Potentially Hazardous Electromagnetic Fields - RF and Microwave [4] is used for guidance in measuring the Specific Absorption Rate (SAR) due to the RF radiation exposure from the Equipment Under Test (EUT). These criteria for SAR evaluation are similar to those recommended by the International Committee for Non-Ionizing Radiation Protection (ICNIRP) in Biological Effects and Exposure Criteria for Radiofrequency Electromagnetic Fields,” Report No. Vol 74. SAR is a measure of the rate of energy absorption due to exposure to an RF transmitting source. SAR values have been related to threshold levels for potential biological hazards.

3.1 SAR Definition

Specific Absorption Rate is defined as the time derivative (rate) of the incremental energy (dU) absorbed by (dissipated in) an incremental mass (dm) contained in a volume element (dV) of a given density (ρ). It is also defined as the rate of RF energy absorption per unit mass at a point in an absorbing body (see Equation 3-1).

**Equation 3-1
SAR Mathematical Equation**

$$SAR = \frac{d}{dt} \left(\frac{dU}{dm} \right) = \frac{d}{dt} \left(\frac{dU}{\rho dv} \right)$$



SAR is expressed in units of Watts per Kilogram (W/kg).

$$SAR = \frac{\sigma \cdot E^2}{\rho}$$

where:

- σ = conductivity of the tissue-simulating material (S/m)
- ρ = mass density of the tissue-simulating material (kg/m³)
- E = Total RMS electric field strength (V/m)

NOTE: The primary factors that control rate of energy absorption were found to be the wavelength of the incident field in relation to the dimensions and geometry of the irradiated organism, the orientation of the organism in relation to the polarity of field vectors, the presence of reflecting surfaces, and whether conductive contact is made by the organism with a ground plane.[6]

FCC ID: ZNFH636	 SAR EVALUATION REPORT 		Reviewed by: Quality Manager
Document S/N: 0Y1503170617.ZNF	Test Dates: 03/17/15 - 04/20/15	DUT Type: Portable Handset	Page 10 of 77

4 DOSIMETRIC ASSESSMENT

4.1 Measurement Procedure

The evaluation was performed using the following procedure compliant to FCC KDB Publication 865664 D01v01 and IEEE 1528-2013:

1. The SAR distribution at the exposed side of the head or body was measured at a distance no greater than 5.0 mm from the inner surface of the shell. The area covered the entire dimension of the device-head and body interface and the horizontal grid resolution was determined per FCC KDB Publication 865664 D01v01 (See Table 4-1) and IEEE 1528-2013.
2. The point SAR measurement was taken at the maximum SAR region determined from Step 1 to enable the monitoring of SAR fluctuations/drifts during the 1g/10g cube evaluation. SAR at this fixed point was measured and used as a reference value.
3. Based on the area scan data, the peak of the region with maximum SAR was determined by spline interpolation. Around this point, a volume was assessed according to the measurement resolution and volume size requirements of FCC KDB Publication 865664 D01v01 (See Table 4-1) and IEEE 1528-2013. On the basis of this data set, the spatial peak SAR value was evaluated with the following procedure (see references or the DASy manual online for more details):
 - a. SAR values at the inner surface of the phantom are extrapolated from the measured values along the line away from the surface with spacing no greater than that in Table 4-1. The extrapolation was based on a least-squares algorithm. A polynomial of the fourth order was calculated through the points in the z-axis (normal to the phantom shell).
 - b. After the maximum interpolated values were calculated between the points in the cube, the SAR was averaged over the spatial volume (1g or 10g) using a 3D-Spline interpolation algorithm. The 3D-spline is composed of three one-dimensional splines with the “Not a knot” condition (in x, y, and z directions). The volume was then integrated with the trapezoidal algorithm. One thousand points (10 x 10 x 10) were obtained through interpolation, in order to calculate the averaged SAR.
 - c. All neighboring volumes were evaluated until no neighboring volume with a higher average value was found.
4. The SAR reference value, at the same location as step 2, was re-measured after the zoom scan was complete to calculate the SAR drift. If the drift deviated by more than 5%, the SAR test and drift measurements were repeated.

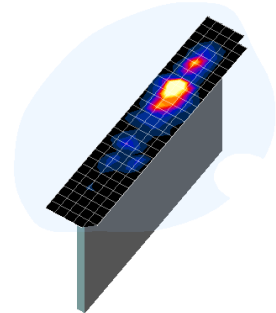

Figure 4-1
Sample SAR Area Scan

Table 4-1
Area and Zoom Scan Resolutions per FCC KDB Publication 865664 D01v01*

Frequency	Maximum Area Scan Resolution (mm) ($\Delta x_{area}, \Delta y_{area}$)	Maximum Zoom Scan Resolution (mm) ($\Delta x_{zoom}, \Delta y_{zoom}$)	Maximum Zoom Scan Spatial Resolution (mm)			Minimum Zoom Scan Volume (mm) (x, y, z)
			Uniform Grid	Graded Grid		
			$\Delta z_{zoom}(n)$	$\Delta z_{zoom}(1)^*$	$\Delta z_{zoom}(n>1)^*$	
≤ 2 GHz	≤ 15	≤ 8	≤ 5	≤ 4	≤ 1.5* $\Delta z_{zoom}(n-1)$	≥ 30
2-3 GHz	≤ 12	≤ 5	≤ 5	≤ 4	≤ 1.5* $\Delta z_{zoom}(n-1)$	≥ 30
3-4 GHz	≤ 12	≤ 5	≤ 4	≤ 3	≤ 1.5* $\Delta z_{zoom}(n-1)$	≥ 28
4-5 GHz	≤ 10	≤ 4	≤ 3	≤ 2.5	≤ 1.5* $\Delta z_{zoom}(n-1)$	≥ 25
5-6 GHz	≤ 10	≤ 4	≤ 2	≤ 2	≤ 1.5* $\Delta z_{zoom}(n-1)$	≥ 22

*Also compliant to IEEE 1528-2013 Table 6

FCC ID: ZNFH636	PCTEST <small>ENGINEERING LABORATORY, INC.</small>		SAR EVALUATION REPORT	LG	Reviewed by: Quality Manager
Document S/N: 0Y1503170617.ZNF	Test Dates: 03/17/15 - 04/20/15	DUT Type: Portable Handset			Page 11 of 77

5 DEFINITION OF REFERENCE POINTS

5.1 EAR REFERENCE POINT

Figure 5-2 shows the front, back and side views of the SAM Twin Phantom. The point “M” is the reference point for the center of the mouth, “LE” is the left ear reference point (ERP), and “RE” is the right ERP. The ERP is 15mm posterior to the entrance to the ear canal (EEC) along the B-M line (Back-Mouth), as shown in Figure 5-1. The plane passing through the two ear canals and M is defined as the Reference Plane. The line N-F (Neck-Front), also called the Reference Pivoting Line, is not perpendicular to the reference plane (see Figure 5-1). Line B-M is perpendicular to the N-F line. Both N-F and B-M lines are marked on the external phantom shell to facilitate handset positioning [5].

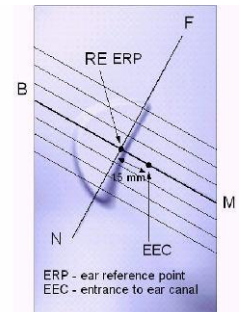

Figure 5-1
Close-Up Side view of ERP

5.2 HANDSET REFERENCE POINTS

Two imaginary lines on the handset were established: the vertical centerline and the horizontal line. The test device was placed in a normal operating position with the acoustic output located along the “vertical centerline” on the front of the device aligned to the “ear reference point” (See Figure 5-3). The acoustic output was then located at the same level as the center of the ear reference point. The test device was positioned so that the “vertical centerline” was bisecting the front surface of the handset at its top and bottom edges, positioning the “ear reference point” on the outer surface of the both the left and right head phantoms on the ear reference point.



Figure 5-2
Front, back and side view of SAM Twin Phantom

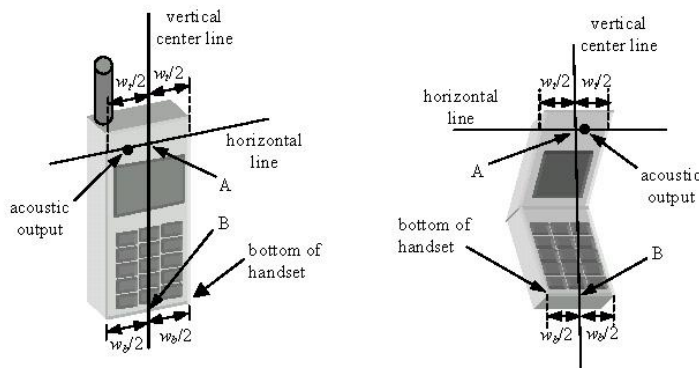



Figure 5-3
Handset Vertical Center & Horizontal Line Reference Points

FCC ID: ZNFH636	 PCTEST ENGINEERING LABORATORY, INC.	SAR EVALUATION REPORT	 LG	Reviewed by: Quality Manager
Document S/N: 0Y1503170617.ZNF	Test Dates: 03/17/15 - 04/20/15	DUT Type: Portable Handset		Page 12 of 77

6 TEST CONFIGURATION POSITIONS FOR HANDSETS

6.1 Device Holder

The device holder is made out of low-loss POM material having the following dielectric parameters: relative permittivity $\epsilon = 3$ and loss tangent $\delta = 0.02$.

6.2 Positioning for Cheek

1. The test device was positioned with the device close to the surface of the phantom such that point A is on the (virtual) extension of the line passing through points RE and LE on the phantom (see Figure 6-1), such that the plane defined by the vertical center line and the horizontal line of the phone is approximately parallel to the sagittal plane of the phantom.

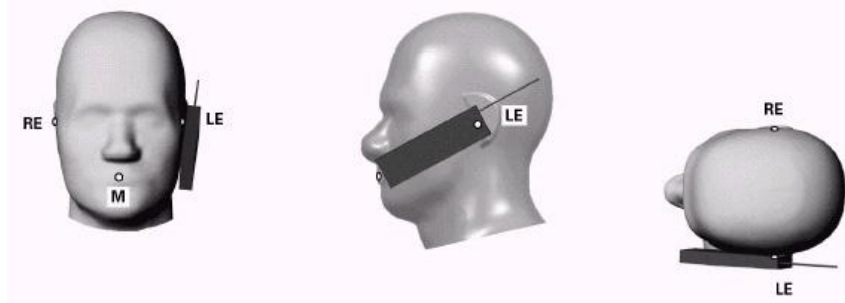



Figure 6-1 Front, Side and Top View of Cheek Position

2. The handset was translated towards the phantom along the line passing through RE & LE until the handset touches the pinna.
3. While maintaining the handset in this plane, the handset was rotated around the LE-RE line until the vertical centerline was in the reference plane.
4. The phone was then rotated around the vertical centerline until the phone (horizontal line) was symmetrical with respect to the line NF.
5. While maintaining the vertical centerline in the reference plane, keeping point A on the line passing through RE and LE, and maintaining the device contact with the ear, the device was rotated about the NF line until any point on the handset made contact with a phantom point below the ear (cheek) (See Figure 6-2).

6.3 Positioning for Ear / 15° Tilt

With the test device aligned in the “Cheek Position”:

1. While maintaining the orientation of the phone, the phone was retracted parallel to the reference plane far enough to enable a rotation of the phone by 15 degrees.
2. The phone was then rotated around the horizontal line by 15 degrees.
3. While maintaining the orientation of the phone, the phone was moved parallel to the reference plane until any part of the handset touched the head. (In this position, point A was located on the line RE-LE). The tilted position is obtained when the contact is on the pinna. If the contact was at any location other than the pinna, the angle of the phone would then be reduced. In this situation, the tilted position was obtained when any part of the phone was in contact of the ear as well as a second part of the phone was in contact with the head (see Figure 6-2).

FCC ID: ZNFH636	 PCTEST ENGINEERING LABORATORY, INC.	SAR EVALUATION REPORT	 LG	Reviewed by: Quality Manager
Document S/N: 0Y1503170617.ZNF	Test Dates: 03/17/15 - 04/20/15	DUT Type: Portable Handset		Page 13 of 77

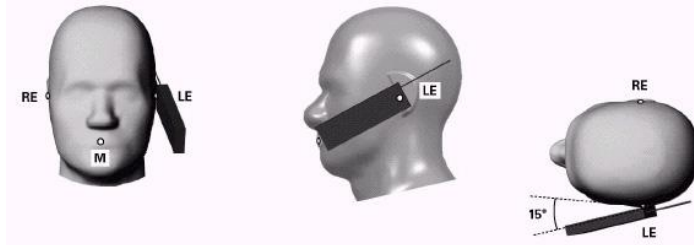

Figure 6-2 Front, Side and Top View of Ear/15° Tilt Position

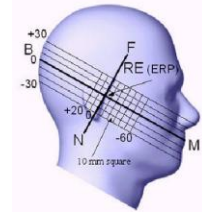

Figure 6-3 Side view w/ relevant markings

6.4 Body-Worn Accessory Configurations

Body-worn operating configurations are tested with the belt-clips and holsters attached to the device and positioned against a flat phantom in a normal use configuration (see Figure 6-4). Per FCC KDB Publication 648474 D04v01, Body-worn accessory exposure is typically related to voice mode operations when handsets are carried in body-worn accessories. The body-worn accessory procedures in FCC KDB Publication 447498 D01v05 should be used to test for body-worn accessory SAR compliance, without a headset connected to it. This enables the test results for such configuration to be compatible with that required for hotspot mode when the body-worn accessory test separation distance is greater than or equal to that required for hotspot mode, when applicable. When the reported SAR for a body-worn accessory, measured without a headset connected to the handset, is $> 1.2 \text{ W/kg}$, the highest reported SAR configuration for that wireless mode and frequency band should be repeated for that body-worn accessory with a headset attached to the handset.

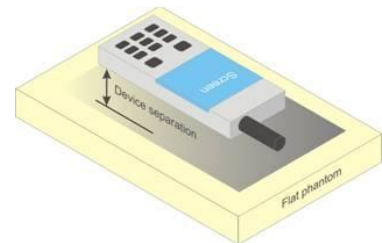



Figure 6-4 Sample Body-Worn Diagram

Accessories for Body-worn operation configurations are divided into two categories: those that do not contain metallic components and those that do contain metallic components. When multiple accessories that do not contain metallic components are supplied with the device, the device is tested with only the accessory that dictates the closest spacing to the body. Then multiple accessories that contain metallic components are tested with the device with each accessory. If multiple accessories share an identical metallic component (i.e. the same metallic belt-clip used with different holsters with no other metallic components) only the accessory that dictates the closest spacing to the body is tested.

Body-worn accessories may not always be supplied or available as options for some devices intended to be authorized for body-worn use. In this case, a test configuration with a separation distance between the back of the device and the flat phantom is used. Test position spacing was documented. Transmitters that are designed to operate in front of a person's face, as in push-to-talk configurations, are tested for SAR compliance with the front of the device positioned to face the flat phantom in head fluid. For devices that are carried next to the body such as a shoulder, waist or chest-worn transmitters, SAR compliance is tested with the accessories, including headsets and microphones, attached to the device and positioned against a flat phantom in a normal use configuration.

FCC ID: ZNFH636	 SAR EVALUATION REPORT 		Reviewed by: Quality Manager
Document S/N: 0Y1503170617.ZNF	Test Dates: 03/17/15 - 04/20/15	DUT Type: Portable Handset	Page 14 of 77

6.5 Extremity Exposure Configurations



Devices that are designed or intended for use on extremities or mainly operated in extremity only exposure conditions; i.e., hands, wrists, feet and ankles, may require extremity SAR evaluation. When the device also operates in close proximity to the user's body, SAR compliance for the body is also required. The 1-g body and 10-g extremity SAR Exclusion Thresholds found in KDB Publication 44798 D01v05 should be applied to determine SAR test requirements.

For smart phones with a display diagonal dimension > 15.0 cm or an overall diagonal dimension > 16.0 cm that provide similar mobile web access and multimedia support found in mini-tablets or UMPC minitables that support voice calls next to the ear, the phablets procedures outlined in KDB Publication 648474 D04 v01r01DR04 should be applied to evaluate SAR compliance. A device marketed as phablets, regardless of form factors and operating characteristics must be tested as a phablet to determine SAR compliance. In addition to the normally required head and body-worn accessory SAR test procedures required for handsets, the UMPC mini-tablet procedures must also be applied to test the SAR of all surfaces and edges with an antenna ≤ 25 mm from that surface or edge, in direct contact with the phantom, for 10-g SAR. The UMPC mini-tablet 1-g SAR at 5 mm is not required. When hotspot mode applies, 10-g SAR is required only for the surfaces and edges with hotspot mode 1-g SAR > 1.2 W/kg.

6.6 Wireless Router Configurations

Some battery-operated handsets have the capability to transmit and receive user data through simultaneous transmission of WIFI simultaneously with a separate licensed transmitter. The FCC has provided guidance in FCC KDB Publication 941225 D06v02 where SAR test considerations for handsets ($L \times W \geq 9 \text{ cm} \times 5 \text{ cm}$) are based on a composite test separation distance of 10 mm from the front, back and edges of the device containing transmitting antennas within 2.5 cm of their edges, determined from general mixed use conditions for this type of devices. Since the hotspot SAR results may overlap with the body-worn accessory SAR requirements, the more conservative configurations can be considered, thus excluding some body-worn accessory SAR tests.

When the user enables the personal wireless router functions for the handset, actual operations include simultaneous transmission of both the WIFI transmitter and another licensed transmitter. Both transmitters often do not transmit at the same transmitting frequency and thus cannot be evaluated for SAR under actual use conditions due to the limitations of the SAR assessment probes. Therefore, SAR must be evaluated for each frequency transmission and mode separately and spatially summed with the WIFI transmitter according to FCC KDB Publication 447498 D01v05 publication procedures. The "Portable Hotspot" feature on the handset was NOT activated during SAR assessments, to ensure the SAR measurements were evaluated for a single transmission frequency RF signal at a time.

FCC ID: ZNFH636	 SAR EVALUATION REPORT 		Reviewed by: Quality Manager
Document S/N: 0Y1503170617.ZNF	Test Dates: 03/17/15 - 04/20/15	DUT Type: Portable Handset	Page 15 of 77

7 RF EXPOSURE LIMITS

7.1 Uncontrolled Environment

UNCONTROLLED ENVIRONMENTS are defined as locations where there is the exposure of individuals who have no knowledge or control of their exposure. The general population/uncontrolled exposure limits are applicable to situations in which the general public may be exposed or in which persons who are exposed as a consequence of their employment may not be made fully aware of the potential for exposure or cannot exercise control over their exposure. Members of the general public would come under this category when exposure is not employment-related; for example, in the case of a wireless transmitter that exposes persons in its vicinity.



7.2 Controlled Environment

CONTROLLED ENVIRONMENTS are defined as locations where there is exposure that may be incurred by persons who are aware of the potential for exposure, (i.e. as a result of employment or occupation). In general, occupational/controlled exposure limits are applicable to situations in which persons are exposed as a consequence of their employment, who have been made fully aware of the potential for exposure and can exercise control over their exposure. This exposure category is also applicable when the exposure is of a transient nature due to incidental passage through a location where the exposure levels may be higher than the general population/uncontrolled limits, but the exposed person is fully aware of the potential for exposure and can exercise control over his or her exposure by leaving the area or by some other appropriate means.

**Table 7-1
SAR Human Exposure Specified in ANSI/IEEE C95.1-1992 and Health Canada Safety Code 6**

HUMAN EXPOSURE LIMITS		
	UNCONTROLLED ENVIRONMENT <i>General Population</i> (W/kg) or (mW/g)	CONTROLLED ENVIRONMENT <i>Occupational</i> (W/kg) or (mW/g)
Peak Spatial Average SAR Head	1.6	8.0
Whole Body SAR	0.08	0.4
Peak Spatial Average SAR Hands, Feet, Ankle, Wrists, etc.	4.0	20

1. The Spatial Peak value of the SAR averaged over any 1 gram of tissue (defined as a tissue volume in the shape of a cube) and over the appropriate averaging time.
2. The Spatial Average value of the SAR averaged over the whole body.
3. The Spatial Peak value of the SAR averaged over any 10 grams of tissue (defined as a tissue volume in the shape of a cube) and over the appropriate averaging time.

FCC ID: ZNFH636	 PCTEST ENGINEERING LABORATORY, INC.	SAR EVALUATION REPORT	 LG	Reviewed by: Quality Manager
Document S/N: 0Y1503170617.ZNF	Test Dates: 03/17/15 - 04/20/15	DUT Type: Portable Handset	Page 16 of 77	

Power measurements were performed using a base station simulator under digital average power.

8.1 Measured and Reported SAR

Per FCC KDB Publication 447498 D01v05, When SAR is not measured at the maximum power level allowed for production units, the results must be scaled to the maximum tune-up tolerance limit according to the power applied to the individual channels tested to determine compliance. For simultaneous transmission, the measured aggregate SAR must be scaled according to the sum of the differences between the maximum tune-up tolerance and actual power used to test each transmitter. When SAR is measured at or scaled to the maximum tune-up tolerance limit, the results are referred to as *reported* SAR. The highest *reported* SAR results are identified on the grant of equipment authorization according to procedures in KDB 690783 D01v01r02.



8.2 3G SAR Test Reduction Procedure

In FCC KDB Publication 941225 D01v03, certain transmission modes within a frequency band and wireless mode evaluated for SAR are defined as primary modes. The equivalent modes considered for SAR test reduction are denoted as secondary modes. When the maximum output power including tuneup tolerance specified for production units in a secondary mode is ≤ 0.25 dB higher than the primary mode or when the highest reported SAR of the primary mode, scaled by the ratio of specified maximum output power and tune-up tolerance of secondary to primary mode, is ≤ 1.2 W/kg, SAR measurements are not required for the secondary mode. These criteria are referred to as the 3G SAR test reduction procedure. When the 3G SAR test reduction procedure is not satisfied, SAR measurements are additionally required for the secondary mode.

8.3 Procedures Used to Establish RF Signal for SAR

The following procedures are according to FCC KDB Publication 941225 D01v03 “SAR Measurement Procedures for 3G Devices”, October 2014.

The device was placed into a simulated call using a base station simulator in a RF shielded chamber. Establishing connections in this manner ensure a consistent means for testing SAR and are recommended for evaluating SAR [4]. Devices under test were evaluated prior to testing, with a fully charged battery and were configured to operate at maximum output power. In order to verify that the device was tested throughout the SAR test at maximum output power, the SAR measurement system measures a “point SAR” at an arbitrary reference point at the start and end of the 1 gram SAR evaluation, to assess for any power drifts during the evaluation. If the power drift deviated by more than 5%, the SAR test and drift measurements were repeated.

FCC ID: ZNFH636	 PCTEST ENGINEERING LABORATORY, INC.	SAR EVALUATION REPORT	 LG	Reviewed by: Quality Manager
Document S/N: 0Y1503170617.ZNF	Test Dates: 03/17/15 - 04/20/15	DUT Type: Portable Handset		Page 17 of 77

8.4 SAR Measurement Conditions for UMTS

8.4.1 Output Power Verification

Maximum output power is verified on the High, Middle and Low channels according to the general descriptions in section 5.2 of 3GPP TS 34.121, using the appropriate RMC with TPC (transmit power control) set to all “1s” or applying the required inner loop power control procedures to maintain maximum output power while HSUPA is active. Results for all applicable physical channel configurations (DPCCH, DPDCHn and spreading codes, HS-DPCCH etc) are tabulated in this test report. All configurations that are not supported by the DUT or cannot be measured due to technical or equipment limitations are identified.

8.4.2 Head SAR Measurements

SAR for next to the ear head exposure is measured using a 12.2 kbps RMC with TPC bits configured to all “1s”. The 3G SAR test reduction procedure is applied to AMR configurations with 12.2 kbps RMC as the primary mode. Otherwise, SAR is measured for 12.2 kbps AMR in 3.4 kbps SRB (signaling radio bearer) using the highest reported SAR configuration in 12.2 kbps RMC for head exposure.

8.4.3 Body SAR Measurements

SAR for body exposure configurations is measured using the 12.2 kbps RMC with the TPC bits all “1s”. The 3G SAR test reduction procedure is applied to other spreading codes and multiple DPDCHn configurations supported by the handset with 12.2 kbps RMC as the primary mode. Otherwise, SAR is measured using an applicable RMC configuration with the corresponding spreading code or DPDCHn, for the highest reported SAR configuration in 12.2 kbps RMC.

8.4.4 SAR Measurements with Rel 5 HSDPA

The 3G SAR test reduction procedure is applied to HSDPA body configurations with 12.2 kbps RMC as the primary mode. Otherwise, Body SAR for HSDPA is measured using an FRC with HSet 1 in Sub-test 1 and a 12.2 kbps RMC configured in Test Loop Mode 1, for the highest reported SAR configuration in 12.2 kbps RMC without HSDPA. Handsets with both HSDPA and HSUPA are tested according to Release 6 HSPA test procedures.



8.4.5 SAR Measurements with Rel 6 HSUPA

The 3G SAR test reduction procedure is applied to HSPA (HSUPA/HSDPA with RMC) body configurations with 12.2 kbps RMC as the primary mode. Otherwise, Body SAR for HSPA is measured with E-DCH Sub-test 5, using H-Set 1 and QPSK for FRC and a 12.2 kbps RMC configured in Test Loop Mode 1 and power control algorithm 2, according to the highest reported body SAR configuration in 12.2 kbps RMC without HSPA.

When VOIP applies to head exposure, the 3G SAR test reduction procedure is applied with 12.2 kbps RMC as the primary mode; otherwise, the same HSPA configuration used for body SAR measurements are applied to head exposure testing.

8.4.6 SAR Measurement Conditions for DC-HSDPA

SAR is required for Rel. 8 DC-HSDPA when SAR is required for Rel. 5 HSDPA; otherwise, the 3G SAR test reduction procedure is applied to DC-HSDPA with 12.2 kbps RMC as the primary mode. Power is measured for DC-HSDPA according to the H-Set 12, FRC configuration in Table C.8.1.12 of 3GPP TS 34.121-1 to determine SAR test reduction. A primary and a secondary serving HSDSCH Cell are required to perform the power measurement and for the results to be acceptable.

FCC ID: ZNFH636	 PCTEST ENGINEERING LABORATORY, INC.	SAR EVALUATION REPORT	 LG	Reviewed by: Quality Manager
Document S/N: 0Y1503170617.ZNF	Test Dates: 03/17/15 - 04/20/15	DUT Type: Portable Handset		Page 18 of 77

8.5 SAR Measurement Conditions for LTE

LTE modes were tested according to FCC KDB 941225 D05v02r03 publication. Please see notes after the tabulated SAR data for required test configurations. Establishing connections with base station simulators ensure a consistent means for testing SAR and are recommended for evaluating SAR [4]. The R&S CMW500 was used for LTE output power measurements and SAR testing. Closed loop power control was used so the UE transmits with maximum output power during SAR testing. SAR tests were performed with the same number of RB and RB offsets transmitting on all TTI frames (maximum TTI).

8.5.1 Spectrum Plots for RB Configurations

A properly configured base station simulator was used for SAR tests and power measurements. Therefore, spectrum plots for RB configurations were not required to be included in this report.

8.5.2 MPR

MPR is permanently implemented for this device by the manufacturer. The specific manufacturer target MPR is indicated alongside the SAR results. MPR is enabled for this device, according to 3GPP TS36.101 Section 6.2.3 – 6.2.5 under Table 6.2.3-1.



8.5.3 A-MPR

A-MPR (Additional MPR) has been disabled for all SAR tests by setting NS=01 on the base station simulator.

8.5.4 Required RB Size and RB Offsets for SAR Testing

According to FCC KDB 941225 D05v02r03:

- a. Per Section 5.2.1, SAR is required for QPSK 1 RB Allocation for the largest bandwidth
 - i. The required channel and offset combination with the highest maximum output power is required for SAR.
 - ii. When the reported SAR is ≤ 0.8 W/kg, testing of the remaining RB offset configurations and required test channels is not required. Otherwise, SAR is required for the remaining required test channels using the RB offset configuration with highest output power for that channel.
 - iii. When the reported SAR for a required test channel is > 1.45 W/kg, SAR is required for all RB offset configurations for that channel.
- b. Per Section 5.2.2, SAR is required for 50% RB allocation using the largest bandwidth following the same procedures outlined in Section 5.2.1.
- c. Per Section 5.2.3, QPSK SAR is not required for the 100% allocation when the highest maximum output power for the 100% allocation is less than the highest maximum output power of the 1 RB and 50% RB allocations and the reported SAR for the 1 RB and 50% RB allocations is < 0.8 W/kg.
- d. Per Section 5.2.4 and 5.3, SAR tests for higher order modulations and lower bandwidths configurations are not required when the conducted power of the required test configurations determined by Sections 5.2.1 through 5.2.3 is less than or equal to $\frac{1}{2}$ dB higher than the equivalent configuration using QPSK modulation and when the QPSK SAR for those configurations is < 1.45 W/kg.

FCC ID: ZNFH636	 PCTEST ENGINEERING LABORATORY, INC.	SAR EVALUATION REPORT	 LG	Reviewed by: Quality Manager
Document S/N: 0Y1503170617.ZNF	Test Dates: 03/17/15 - 04/20/15	DUT Type: Portable Handset		Page 19 of 77

8.6 SAR Testing with 802.11 Transmitters

The normal network operating configurations of 802.11 transmitters are not suitable for SAR measurements. Unpredictable fluctuations in network traffic and antenna diversity conditions can introduce undesirable variations in SAR results. The SAR for these devices should be measured using chipset based test mode software to ensure the results are consistent and reliable. See KDB Publication 248227 D01v02 for more details.

8.6.1 General Device Setup

Chipset based test mode software is hardware dependent and generally varies among manufacturers. The device operating parameters established in test mode for SAR measurements must be identical to those programmed in production units, including output power levels, amplifier gain settings and other RF performance tuning parameters.

A periodic duty factor is required for current generation SAR systems to measure SAR. When 802.11 frame gaps are accounted for in the transmission, a maximum transmission duty factor of 92 - 96% is typically achievable in most test mode configurations. A minimum transmission duty factor of 85% is required to avoid certain hardware and device implementation issues related to wide range SAR scaling. The reported SAR is scaled to 100% transmission duty factor to determine compliance at the maximum tune-up tolerance limit.



8.6.2 U-NII-1 and U-NII-2A

For devices that operate in both U-NII-1 and U-NII-2A bands, when the same maximum output power is specified for both bands, SAR measurement using OFDM SAR test procedures is not required for U-NII-1 unless the highest reported SAR for U-NII-2A is > 1.2 W/kg. When different maximum output powers are specified for the bands, SAR measurement for the U-NII band with the lower maximum output power is not required unless the highest reported SAR for the U-NII band with the higher maximum output power, adjusted by the ratio of lower to higher specified maximum output power for the two bands, is > 1.2 W/kg.

8.6.3 U-NII-2C and U-NII-3

The frequency range covered by U-NII-2C and U-NII-3 is 380 MHz (5.47 – 5.85 GHz), which requires a minimum of at least two SAR probe calibration frequency points to support SAR measurements. When Terminal Doppler Weather Radar (TDWR) restriction applies, the channels at 5.60 – 5.65 GHz in U-NII-2C band must be disabled with acceptable mechanisms and documented in the equipment certification.

Unless band gap channels are permanently disabled, SAR must be considered for these channels. To maintain SAR measurement accuracy and to facilitate test reduction, the channels in U-NII-2C band above 5.65 GHz are grouped with the 5.8 GHz channels in U-NII-3 band or §15.247 5.8 GHz band to enable two SAR probe calibration frequency points to cover the bands, including the band gap channels. When band gap channels are disabled, each band is tested independently according to the normally required OFDM SAR measurement and probe calibration frequency points requirements.

FCC ID: ZNFH636	 PCTEST ENGINEERING LABORATORY, INC.	SAR EVALUATION REPORT		Reviewed by: Quality Manager
Document S/N: 0Y1503170617.ZNF	Test Dates: 03/17/15 - 04/20/15	DUT Type: Portable Handset		Page 20 of 77

8.6.4 Initial Test Position Procedure

For exposure conditions with multiple test positions, such as handset operating next to the ear, devices with hotspot mode or UMPC mini-tablet, procedures for initial test position can be applied. Using the transmission mode determined by the DSSS procedure or initial test configuration, area scans are measured for all positions in an exposure condition. The test position with the highest extrapolated (peak) SAR is used as the initial test position. When reported SAR for the initial test position is ≤ 0.4 W/kg, no additional testing for the remaining test positions is required. Otherwise, SAR is evaluated at the subsequent highest peak SAR positions until the reported SAR result is ≤ 0.8 W/kg or all test positions are measured.

8.6.5 2.4 GHz SAR Test Requirements



SAR is measured for 2.4 GHz 802.11b DSSS using either the fixed test position or, when applicable, the initial test position procedure. SAR test reduction is determined according to the following:

- 1) When the reported SAR of the highest measured maximum output power channel for the exposure configuration is ≤ 0.8 W/kg, no further SAR testing is required for 802.11b DSSS in that exposure configuration.
- 2) When the reported SAR is > 0.8 W/kg, SAR is required for that position using the next highest measured output power channel. When any reported SAR is > 1.2 W/kg, SAR is required for the third channel; i.e., all channels require testing.

2.4 GHz 802.11 g/n OFDM are additionally evaluated for SAR if the highest reported SAR for 802.11b, adjusted by the ratio of the OFDM to DSSS specified maximum output power, is > 1.2 W/kg. When SAR is required for OFDM modes in 2.4 GHz band, the Initial Test Configuration Procedures should be followed.

8.6.6 OFDM Transmission Mode and SAR Test Channel Selection

For the 2.4 GHz and 5 GHz bands, when the same maximum output power was specified for multiple OFDM transmission mode configurations in a frequency band or aggregated band, SAR is measured using the configuration with the largest channel bandwidth, lowest order modulation and lowest data rate. When the maximum output power of a channel is the same for equivalent OFDM configurations; for example, 802.11a, 802.11n and 802.11ac or 802.11g and 802.11n with the same channel bandwidth, modulation and data rate etc., the lower order 802.11 mode i.e., 802.11a, then 802.11n and 802.11ac or 802.11g then 802.11n, is used for SAR measurement. When the maximum output power are the same for multiple test channels, either according to the default or additional power measurement requirements, SAR is measured using the channel closest to the middle of the frequency band or aggregated band. When there are multiple channels with the same maximum output power, SAR is measured using the higher number channel.

FCC ID: ZNFH636	 PCTEST ENGINEERING LABORATORY, INC.	SAR EVALUATION REPORT	 LG	Reviewed by: Quality Manager
Document S/N: 0Y1503170617.ZNF	Test Dates: 03/17/15 - 04/20/15	DUT Type: Portable Handset	Page 21 of 77	



8.6.7 Initial Test Configuration Procedure

For OFDM, in both 2.4 and 5 GHz bands, an initial test configuration is determined for each frequency band and aggregated band, according to the transmission mode with the highest maximum output power specified for SAR measurements. When the same maximum output power is specified for multiple OFDM transmission mode configurations in a frequency band or aggregated band, SAR is measured using the configuration(s) with the largest channel bandwidth, lowest order modulation, and lowest data rate. If the average RF output powers of the highest identical transmission modes are within 0.25 dB of each other, mid channel of the transmission mode with highest average RF output power is the initial test channel. Otherwise, the channel of the transmission mode with the highest average RF output conducted power will be the initial test configuration.

When the reported SAR is ≤ 0.8 W/kg, no additional measurements on other test channels are required. Otherwise, SAR is evaluated using the subsequent highest average RF output channel until the reported SAR result is ≤ 1.2 W/kg or all channels are measured. When there are multiple untested channels having the same subsequent highest average RF output power, the channel with higher frequency from the lowest 802.11 mode is considered for SAR measurements (See Section 8.6.6).

8.6.8 Subsequent Test Configuration Procedures

For OFDM configurations in each frequency band and aggregated band, SAR is evaluated for initial test configuration using the fixed test position or the initial test position procedure. When the highest reported SAR (for the initial test configuration), adjusted by the ratio of the specified maximum output power of the subsequent test configuration to initial test configuration, is ≤ 1.2 W/kg, no additional SAR tests for the subsequent test configurations are required.

FCC ID: ZNFH636	 SAR EVALUATION REPORT 		Reviewed by: Quality Manager
Document S/N: 0Y1503170617.ZNF	Test Dates: 03/17/15 - 04/20/15	DUT Type: Portable Handset	Page 22 of 77

9 RF CONDUCTED POWERS

9.1 GSM Conducted Powers

		Maximum Burst-Averaged Output Power									
		Voice	GPRS/EDGE Data (GMSK)				EDGE Data (8-PSK)				
Band	Channel	GSM [dBm] CS (1 Slot)	GPRS [dBm] 1 Tx Slot	GPRS [dBm] 2 Tx Slot	GPRS [dBm] 3 Tx Slot	GPRS [dBm] 4 Tx Slot	EDGE [dBm] 1 Tx Slot	EDGE [dBm] 2 Tx Slot	EDGE [dBm] 3 Tx Slot	EDGE [dBm] 4 Tx Slot	
GSM 850	128	33.54	33.53	29.70	27.59	26.64	26.67	26.57	24.43	23.66	
	190	33.62	33.59	29.70	27.70	26.70	26.64	26.70	24.63	23.70	
	251	33.61	33.61	29.67	27.53	26.47	26.70	26.55	24.53	23.53	
GSM 1900	512	31.18	31.04	27.93	26.80	25.17	25.61	25.67	25.10	24.20	
	661	31.06	30.93	27.70	26.83	24.90	25.70	25.52	24.95	23.99	
	810	30.90	30.79	27.87	26.82	24.85	25.68	25.41	25.06	24.00	
		Calculated Maximum Frame-Averaged Output Power									
		Voice	GPRS/EDGE Data (GMSK)				EDGE Data (8-PSK)				
Band	Channel	GSM [dBm] CS (1 Slot)	GPRS [dBm] 1 Tx Slot	GPRS [dBm] 2 Tx Slot	GPRS [dBm] 3 Tx Slot	GPRS [dBm] 4 Tx Slot	EDGE [dBm] 1 Tx Slot	EDGE [dBm] 2 Tx Slot	EDGE [dBm] 3 Tx Slot	EDGE [dBm] 4 Tx Slot	
GSM 850	128	24.51	24.50	23.68	23.33	23.63	17.64	20.55	20.17	20.65	
	190	24.59	24.56	23.68	23.44	23.69	17.61	20.68	20.37	20.69	
	251	24.58	24.58	23.65	23.27	23.46	17.67	20.53	20.27	20.52	
GSM 1900	512	22.15	22.01	21.91	22.54	22.16	16.58	19.65	20.84	21.19	
	661	22.03	21.90	21.68	22.57	21.89	16.67	19.50	20.69	20.98	
	810	21.67	21.76	21.85	22.56	21.84	16.65	19.39	20.80	20.99	
GSM 850	Frame Avg.Targets:	24.17	24.17	23.18	22.94	23.19	17.17	20.18	19.94	20.19	
GSM 1900	Frame Avg.Targets:	21.67	21.67	21.68	22.44	21.69	16.17	19.18	20.44	20.69	

Note:

- Both burst-averaged and calculated frame-averaged powers are included. Frame-averaged power was calculated from the measured burst-averaged power by converting the slot powers into linear units and calculating the energy over 8 timeslots.
- Per October 2013 TCB Workshop Notes, the source-based frame-averaged output power was evaluated for all GPRS/EDGE slot configurations. The configuration with the highest target frame averaged output power was evaluated for SAR. When the maximum frame-averaged powers are equivalent across two or more slots (within 0.25 dB), the configuration with the most number of time slots was tested.
- GPRS/EDGE (GMSK) output powers were measured with coding scheme setting of 1 (CS1) on the base station simulator. CS1 was configured to measure GPRS output power measurements and SAR to ensure GMSK modulation in the signal. Our Investigation has shown that CS1 - CS4 settings do not have any impact on the output levels or modulation in the GPRS modes.
- EDGE (8-PSK) output powers were measured with MCS7 on the base station simulator. MCS7 coding scheme was used to measure the output powers for EDGE since investigation has shown that choosing MCS7 coding scheme will ensure 8-PSK modulation. It has been shown that MCS levels that produce 8PSK modulation do not have an impact on output power.

GSM Class: B
GPRS Multislot class: 12 (Max 4 Tx uplink slots)
EDGE Multislot class: 12 (Max 4 Tx uplink slots)
DTM Multislot Class: N/A

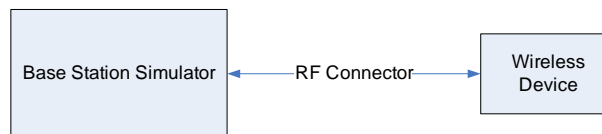

Figure 9-1
Power Measurement Setup

FCC ID: ZNFH636	SAR EVALUATION REPORT		Reviewed by: Quality Manager
Document S/N: 0Y1503170617.ZNF	Test Dates: 03/17/15 - 04/20/15	DUT Type: Portable Handset	Page 23 of 77

9.2 UMTS Conducted Powers

3GPP Release Version	Mode	3GPP 34.121 Subtest	Cellular Band [dBm]			AWS Band [dBm]			PCS Band [dBm]			3GPP MPR [dB]
			4132	4183	4233	1312	1412	1862	9262	9400	9538	
99	WCDMA	12.2 kbps RMC	24.69	24.70	24.68	23.69	23.68	23.66	24.67	24.70	24.69	-
99		12.2 kbps AMR	24.69	24.70	24.66	23.70	23.67	23.67	24.70	24.66	24.68	-
6	HSDPA	Subtest 1	24.69	24.70	24.65	23.69	23.67	23.66	24.67	24.63	24.69	0
6		Subtest 2	24.70	24.68	24.69	23.67	23.68	23.64	24.70	24.68	24.70	0
6		Subtest 3	24.16	24.16	24.11	23.16	23.19	23.23	24.13	24.05	24.18	0.5
6		Subtest 4	24.13	24.12	24.07	23.09	23.13	23.19	24.07	24.04	24.15	0.5
6	HSUPA	Subtest 1	24.43	24.46	24.43	23.49	23.52	23.57	24.48	24.47	24.56	0
6		Subtest 2	23.53	23.10	23.38	22.29	22.54	22.68	23.36	23.26	23.38	2
6		Subtest 3	23.31	23.23	23.47	22.65	22.57	22.67	23.02	23.30	23.40	1
6		Subtest 4	23.68	23.51	23.70	22.15	22.64	22.70	23.42	23.43	23.66	2
6		Subtest 5	24.46	24.51	24.41	23.52	23.55	23.56	24.49	24.41	24.55	0
8	DC-HSDPA	Subtest 1	24.52	24.51	24.46	23.50	23.58	23.66	24.59	24.62	24.57	0
8		Subtest 2	24.51	24.35	24.54	23.58	23.63	23.49	24.55	24.49	24.50	0
8		Subtest 3	23.70	23.72	23.70	22.80	22.82	22.63	23.73	23.62	23.66	0.5
8		Subtest 4	23.76	23.63	23.65	22.77	22.86	22.78	23.81	23.76	23.67	0.5

DC-HSDPA considerations

- 3GPP Specification 34.121-1 Release 8 Ver 8.10.0 was used for DC-HSDPA guidance
- H-Set 12 (QPSK) was confirmed to be used during DC-HSDPA measurements
- The DUT supports UE category 24 for HSDPA

It is expected by the manufacturer that MPR for some HSPA subtests may be up to 1 dB more than specified by 3GPP, but also as low as 0 dB according to the chipset implementation in this model.

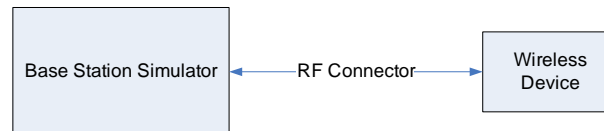



Figure 9-2
Power Measurement Setup

FCC ID: ZNFH636	 SAR EVALUATION REPORT 		Reviewed by: Quality Manager
Document S/N: 0Y1503170617.ZNF	Test Dates: 03/17/15 - 04/20/15	DUT Type: Portable Handset	Page 24 of 77

9.3 LTE Conducted Powers



9.3.1

LTE Band 12

Table 9-1
LTE Band 12 Conducted Powers - 10 MHz Bandwidth



	Frequency [MHz]	Channel	Bandwidth [MHz]	Modulation	RB Size	RB Offset	Conducted Power [dBm]	MPR Allowed per 3GPP [dB]	MPR [dB]
Mid	707.5	23095	10	QPSK	1	0	24.20	0	0
	707.5	23095	10	QPSK	1	25	24.53	0	0
	707.5	23095	10	QPSK	1	49	24.25	0	0
	707.5	23095	10	QPSK	25	0	23.48	0-1	1
	707.5	23095	10	QPSK	25	12	23.61	0-1	1
	707.5	23095	10	QPSK	25	25	23.56	0-1	1
	707.5	23095	10	QPSK	50	0	23.60	0-1	1
	707.5	23095	10	16QAM	1	0	23.68	0-1	1
	707.5	23095	10	16QAM	1	25	23.33	0-1	1
	707.5	23095	10	16QAM	1	49	23.50	0-1	1
	707.5	23095	10	16QAM	25	0	22.53	0-2	2
	707.5	23095	10	16QAM	25	12	22.44	0-2	2
	707.5	23095	10	16QAM	25	25	22.47	0-2	2
707.5	23095	10	16QAM	50	0	22.55	0-2	2	

Note: LTE Band 12 at 10 MHz bandwidth does not support three non-overlapping channels. Per KDB Publication 941225 D05v02r03, when a device supports overlapping channel assignment in a channel bandwidth configuration, the middle channel of the group of overlapping channels should be selected for testing.

FCC ID: ZNFH636	 SAR EVALUATION REPORT 		Reviewed by: Quality Manager
Document S/N: 0Y1503170617.ZNF	Test Dates: 03/17/15 - 04/20/15	DUT Type: Portable Handset	Page 25 of 77



**Table 9-2
LTE Band 12 Conducted Powers - 5 MHz Bandwidth**

	Frequency [MHz]	Channel	Bandwidth [MHz]	Modulation	RB Size	RB Offset	Conducted Power [dBm]	MPR Allowed per 3GPP [dB]	MPR [dB]
Low	701.5	23035	5	QPSK	1	0	24.45	0	0
	701.5	23035	5	QPSK	1	12	24.64	0	0
	701.5	23035	5	QPSK	1	24	24.48	0	0
	701.5	23035	5	QPSK	12	0	23.38	0-1	1
	701.5	23035	5	QPSK	12	6	23.46	0-1	1
	701.5	23035	5	QPSK	12	13	23.43	0-1	1
	701.5	23035	5	QPSK	25	0	23.45	0-1	1
	701.5	23035	5	16-QAM	1	0	23.51	0-1	1
	701.5	23035	5	16-QAM	1	12	23.54	0-1	1
	701.5	23035	5	16-QAM	1	24	23.14	0-1	1
	701.5	23035	5	16-QAM	12	0	22.35	0-2	2
	701.5	23035	5	16-QAM	12	6	22.37	0-2	2
701.5	23035	5	16-QAM	12	13	22.34	0-2	2	
701.5	23035	5	16-QAM	25	0	22.47	0-2	2	
Mid	707.5	23095	5	QPSK	1	0	24.47	0	0
	707.5	23095	5	QPSK	1	12	24.63	0	0
	707.5	23095	5	QPSK	1	24	24.57	0	0
	707.5	23095	5	QPSK	12	0	23.50	0-1	1
	707.5	23095	5	QPSK	12	6	23.52	0-1	1
	707.5	23095	5	QPSK	12	13	23.54	0-1	1
	707.5	23095	5	QPSK	25	0	23.47	0-1	1
	707.5	23095	5	16-QAM	1	0	23.59	0-1	1
	707.5	23095	5	16-QAM	1	12	23.69	0-1	1
	707.5	23095	5	16-QAM	1	24	23.64	0-1	1
	707.5	23095	5	16-QAM	12	0	22.24	0-2	2
	707.5	23095	5	16-QAM	12	6	22.43	0-2	2
707.5	23095	5	16-QAM	12	13	22.54	0-2	2	
707.5	23095	5	16-QAM	25	0	22.48	0-2	2	
High	713.5	23155	5	QPSK	1	0	24.58	0	0
	713.5	23155	5	QPSK	1	12	24.69	0	0
	713.5	23155	5	QPSK	1	24	24.47	0	0
	713.5	23155	5	QPSK	12	0	23.47	0-1	1
	713.5	23155	5	QPSK	12	6	23.48	0-1	1
	713.5	23155	5	QPSK	12	13	23.42	0-1	1
	713.5	23155	5	QPSK	25	0	23.46	0-1	1
	713.5	23155	5	16-QAM	1	0	23.49	0-1	1
	713.5	23155	5	16-QAM	1	12	23.56	0-1	1
	713.5	23155	5	16-QAM	1	24	23.38	0-1	1
	713.5	23155	5	16-QAM	12	0	22.41	0-2	2
	713.5	23155	5	16-QAM	12	6	22.44	0-2	2
713.5	23155	5	16-QAM	12	13	22.39	0-2	2	
713.5	23155	5	16-QAM	25	0	22.58	0-2	2	

FCC ID: ZNFH636		SAR EVALUATION REPORT		Reviewed by: Quality Manager
Document S/N: 0Y1503170617.ZNF	Test Dates: 03/17/15 - 04/20/15	DUT Type: Portable Handset		Page 26 of 77



**Table 9-3
LTE Band 12 Conducted Powers - 3 MHz Bandwidth**

	Frequency [MHz]	Channel	Bandwidth [MHz]	Modulation	RB Size	RB Offset	Conducted Power [dBm]	MPR Allowed per 3GPP [dB]	MPR [dB]
Low	700.5	23025	3	QPSK	1	0	24.70	0	0
	700.5	23025	3	QPSK	1	7	24.68	0	0
	700.5	23025	3	QPSK	1	14	24.59	0	0
	700.5	23025	3	QPSK	8	0	23.68	0-1	1
	700.5	23025	3	QPSK	8	4	23.66	0-1	1
	700.5	23025	3	QPSK	8	7	23.68	0-1	1
	700.5	23025	3	QPSK	15	0	23.66	0-1	1
	700.5	23025	3	16-QAM	1	0	23.60	0-1	1
	700.5	23025	3	16-QAM	1	7	23.57	0-1	1
	700.5	23025	3	16-QAM	1	14	23.52	0-1	1
	700.5	23025	3	16-QAM	8	0	22.63	0-2	2
	700.5	23025	3	16-QAM	8	4	22.55	0-2	2
700.5	23025	3	16-QAM	8	7	22.58	0-2	2	
700.5	23025	3	16-QAM	15	0	22.59	0-2	2	
Mid	707.5	23095	3	QPSK	1	0	24.39	0	0
	707.5	23095	3	QPSK	1	7	24.60	0	0
	707.5	23095	3	QPSK	1	14	24.48	0	0
	707.5	23095	3	QPSK	8	0	23.65	0-1	1
	707.5	23095	3	QPSK	8	4	23.61	0-1	1
	707.5	23095	3	QPSK	8	7	23.67	0-1	1
	707.5	23095	3	QPSK	15	0	23.67	0-1	1
	707.5	23095	3	16-QAM	1	0	23.49	0-1	1
	707.5	23095	3	16-QAM	1	7	23.40	0-1	1
	707.5	23095	3	16-QAM	1	14	23.30	0-1	1
	707.5	23095	3	16-QAM	8	0	22.38	0-2	2
	707.5	23095	3	16-QAM	8	4	22.22	0-2	2
707.5	23095	3	16-QAM	8	7	22.27	0-2	2	
707.5	23095	3	16-QAM	15	0	22.55	0-2	2	
High	714.5	23165	3	QPSK	1	0	24.66	0	0
	714.5	23165	3	QPSK	1	7	24.70	0	0
	714.5	23165	3	QPSK	1	14	24.58	0	0
	714.5	23165	3	QPSK	8	0	23.57	0-1	1
	714.5	23165	3	QPSK	8	4	23.55	0-1	1
	714.5	23165	3	QPSK	8	7	23.50	0-1	1
	714.5	23165	3	QPSK	15	0	23.59	0-1	1
	714.5	23165	3	16-QAM	1	0	23.66	0-1	1
	714.5	23165	3	16-QAM	1	7	23.70	0-1	1
	714.5	23165	3	16-QAM	1	14	23.38	0-1	1
	714.5	23165	3	16-QAM	8	0	22.59	0-2	2
	714.5	23165	3	16-QAM	8	4	22.57	0-2	2
714.5	23165	3	16-QAM	8	7	22.64	0-2	2	
714.5	23165	3	16-QAM	15	0	22.48	0-2	2	

FCC ID: ZNFH636		SAR EVALUATION REPORT		Reviewed by: Quality Manager
Document S/N: 0Y1503170617.ZNF	Test Dates: 03/17/15 - 04/20/15	DUT Type: Portable Handset		Page 27 of 77

**Table 9-4
LTE Band 12 Conducted Powers - 1.4 MHz Bandwidth**

	Frequency [MHz]	Channel	Bandwidth [MHz]	Modulation	RB Size	RB Offset	Conducted Power [dBm]	MPR Allowed per 3GPP [dB]	MPR [dB]
Low	699.7	23017	1.4	QPSK	1	0	24.56	0	0
	699.7	23017	1.4	QPSK	1	2	24.57	0	0
	699.7	23017	1.4	QPSK	1	5	24.48	0	0
	699.7	23017	1.4	QPSK	3	0	24.47	0	0
	699.7	23017	1.4	QPSK	3	2	24.65	0	0
	699.7	23017	1.4	QPSK	3	3	24.66	0	0
	699.7	23017	1.4	QPSK	6	0	23.65	0-1	1
	699.7	23017	1.4	16-QAM	1	0	23.48	0-1	1
	699.7	23017	1.4	16-QAM	1	2	23.51	0-1	1
	699.7	23017	1.4	16-QAM	1	5	23.46	0-1	1
	699.7	23017	1.4	16-QAM	3	0	23.22	0-1	1
	699.7	23017	1.4	16-QAM	3	2	23.45	0-1	1
	699.7	23017	1.4	16-QAM	3	3	23.18	0-1	1
699.7	23017	1.4	16-QAM	6	0	22.70	0-2	2	
Mid	707.5	23095	1.4	QPSK	1	0	24.59	0	0
	707.5	23095	1.4	QPSK	1	2	24.62	0	0
	707.5	23095	1.4	QPSK	1	5	24.67	0	0
	707.5	23095	1.4	QPSK	3	0	24.52	0	0
	707.5	23095	1.4	QPSK	3	2	24.63	0	0
	707.5	23095	1.4	QPSK	3	3	24.55	0	0
	707.5	23095	1.4	QPSK	6	0	23.64	0-1	1
	707.5	23095	1.4	16-QAM	1	0	23.57	0-1	1
	707.5	23095	1.4	16-QAM	1	2	23.56	0-1	1
	707.5	23095	1.4	16-QAM	1	5	23.31	0-1	1
	707.5	23095	1.4	16-QAM	3	0	23.70	0-1	1
	707.5	23095	1.4	16-QAM	3	2	23.57	0-1	1
	707.5	23095	1.4	16-QAM	3	3	23.60	0-1	1
707.5	23095	1.4	16-QAM	6	0	22.21	0-2	2	
High	715.3	23173	1.4	QPSK	1	0	24.68	0	0
	715.3	23173	1.4	QPSK	1	2	24.42	0	0
	715.3	23173	1.4	QPSK	1	5	24.68	0	0
	715.3	23173	1.4	QPSK	3	0	24.67	0	0
	715.3	23173	1.4	QPSK	3	2	24.43	0	0
	715.3	23173	1.4	QPSK	3	3	24.56	0	0
	715.3	23173	1.4	QPSK	6	0	23.50	0-1	1
	715.3	23173	1.4	16-QAM	1	0	23.56	0-1	1
	715.3	23173	1.4	16-QAM	1	2	23.66	0-1	1
	715.3	23173	1.4	16-QAM	1	5	23.44	0-1	1
	715.3	23173	1.4	16-QAM	3	0	23.65	0-1	1
	715.3	23173	1.4	16-QAM	3	2	23.58	0-1	1
	715.3	23173	1.4	16-QAM	3	3	23.49	0-1	1
715.3	23173	1.4	16-QAM	6	0	22.54	0-2	2	

FCC ID: ZNFH636	 SAR EVALUATION REPORT 	Reviewed by: Quality Manager
Document S/N: 0Y1503170617.ZNF	Test Dates: 03/17/15 - 04/20/15	DUT Type: Portable Handset
		Page 28 of 77

9.3.2

LTE Band 5 (Cell)

**Table 9-5
LTE Band 5 (Cell) Conducted Powers - 10 MHz Bandwidth**

	Frequency [MHz]	Channel	Bandwidth [MHz]	Modulation	RB Size	RB Offset	Conducted Power [dBm]	MPR Allowed per 3GPP [dB]	MPR [dB]
Mid	836.5	20525	10	QPSK	1	0	24.06	0	0
	836.5	20525	10	QPSK	1	25	24.11	0	0
	836.5	20525	10	QPSK	1	49	24.04	0	0
	836.5	20525	10	QPSK	25	0	23.08	0-1	1
	836.5	20525	10	QPSK	25	12	23.02	0-1	1
	836.5	20525	10	QPSK	25	25	23.11	0-1	1
	836.5	20525	10	QPSK	50	0	23.01	0-1	1
	836.5	20525	10	16QAM	1	0	22.99	0-1	1
	836.5	20525	10	16QAM	1	25	22.88	0-1	1
	836.5	20525	10	16QAM	1	49	23.08	0-1	1
	836.5	20525	10	16QAM	25	0	22.20	0-2	2
	836.5	20525	10	16QAM	25	12	22.19	0-2	2
	836.5	20525	10	16QAM	25	25	22.18	0-2	2
	836.5	20525	10	16QAM	50	0	22.16	0-2	2

Note: LTE Band 5 (Cell) at 10 MHz bandwidth does not support three non-overlapping channels. Per KDB Publication 941225 D05v02r03, when a device supports overlapping channel assignment in a channel bandwidth configuration, the middle channel of the group of overlapping channels should be selected for testing.





FCC ID: ZNFH636	 SAR EVALUATION REPORT			Reviewed by: Quality Manager
Document S/N: 0Y1503170617.ZNF	Test Dates: 03/17/15 - 04/20/15	DUT Type: Portable Handset		Page 29 of 77



Table 9-6
LTE Band 5 (Cell) Conducted Powers - 5 MHz Bandwidth

	Frequency [MHz]	Channel	Bandwidth [MHz]	Modulation	RB Size	RB Offset	Conducted Power [dBm]	MPR Allowed per 3GPP [dB]	MPR [dB]
Low	826.5	20425	5	QPSK	1	0	24.04	0	0
	826.5	20425	5	QPSK	1	12	24.07	0	0
	826.5	20425	5	QPSK	1	24	23.97	0	0
	826.5	20425	5	QPSK	12	0	22.97	0-1	1
	826.5	20425	5	QPSK	12	6	22.99	0-1	1
	826.5	20425	5	QPSK	12	13	22.98	0-1	1
	826.5	20425	5	QPSK	25	0	23.04	0-1	1
	826.5	20425	5	16-QAM	1	0	22.65	0-1	1
	826.5	20425	5	16-QAM	1	12	22.89	0-1	1
	826.5	20425	5	16-QAM	1	24	22.93	0-1	1
	826.5	20425	5	16-QAM	12	0	21.84	0-2	2
	826.5	20425	5	16-QAM	12	6	21.92	0-2	2
	826.5	20425	5	16-QAM	12	13	21.95	0-2	2
826.5	20425	5	16-QAM	25	0	22.14	0-2	2	
Mid	836.5	20525	5	QPSK	1	0	23.76	0	0
	836.5	20525	5	QPSK	1	12	24.00	0	0
	836.5	20525	5	QPSK	1	24	23.91	0	0
	836.5	20525	5	QPSK	12	0	22.94	0-1	1
	836.5	20525	5	QPSK	12	6	22.88	0-1	1
	836.5	20525	5	QPSK	12	13	22.97	0-1	1
	836.5	20525	5	QPSK	25	0	22.86	0-1	1
	836.5	20525	5	16-QAM	1	0	22.50	0-1	1
	836.5	20525	5	16-QAM	1	12	22.81	0-1	1
	836.5	20525	5	16-QAM	1	24	22.95	0-1	1
	836.5	20525	5	16-QAM	12	0	21.94	0-2	2
	836.5	20525	5	16-QAM	12	6	21.77	0-2	2
	836.5	20525	5	16-QAM	12	13	21.82	0-2	2
836.5	20525	5	16-QAM	25	0	21.99	0-2	2	
High	846.5	20625	5	QPSK	1	0	23.92	0	0
	846.5	20625	5	QPSK	1	12	23.91	0	0
	846.5	20625	5	QPSK	1	24	23.88	0	0
	846.5	20625	5	QPSK	12	0	22.83	0-1	1
	846.5	20625	5	QPSK	12	6	22.89	0-1	1
	846.5	20625	5	QPSK	12	13	22.91	0-1	1
	846.5	20625	5	QPSK	25	0	22.88	0-1	1
	846.5	20625	5	16-QAM	1	0	22.93	0-1	1
	846.5	20625	5	16-QAM	1	12	22.89	0-1	1
	846.5	20625	5	16-QAM	1	24	22.76	0-1	1
	846.5	20625	5	16-QAM	12	0	22.01	0-2	2
	846.5	20625	5	16-QAM	12	6	22.04	0-2	2
	846.5	20625	5	16-QAM	12	13	21.74	0-2	2
846.5	20625	5	16-QAM	25	0	21.98	0-2	2	

FCC ID: ZNFH636	 SAR EVALUATION REPORT 	Reviewed by: Quality Manager
Document S/N: 0Y1503170617.ZNF	Test Dates: 03/17/15 - 04/20/15	DUT Type: Portable Handset
		Page 30 of 77



**Table 9-7
LTE Band 5 (Cell) Conducted Powers - 3 MHz Bandwidth**

	Frequency [MHz]	Channel	Bandwidth [MHz]	Modulation	RB Size	RB Offset	Conducted Power [dBm]	MPR Allowed per 3GPP [dB]	MPR [dB]
Low	825.5	20415	3	QPSK	1	0	24.15	0	0
	825.5	20415	3	QPSK	1	7	24.19	0	0
	825.5	20415	3	QPSK	1	14	24.16	0	0
	825.5	20415	3	QPSK	8	0	23.13	0-1	1
	825.5	20415	3	QPSK	8	4	23.08	0-1	1
	825.5	20415	3	QPSK	8	7	23.12	0-1	1
	825.5	20415	3	QPSK	15	0	23.05	0-1	1
	825.5	20415	3	16-QAM	1	0	23.11	0-1	1
	825.5	20415	3	16-QAM	1	7	22.90	0-1	1
	825.5	20415	3	16-QAM	1	14	23.20	0-1	1
	825.5	20415	3	16-QAM	8	0	21.82	0-2	2
	825.5	20415	3	16-QAM	8	4	22.14	0-2	2
	825.5	20415	3	16-QAM	8	7	21.94	0-2	2
825.5	20415	3	16-QAM	15	0	22.04	0-2	2	
Mid	836.5	20525	3	QPSK	1	0	24.07	0	0
	836.5	20525	3	QPSK	1	7	24.12	0	0
	836.5	20525	3	QPSK	1	14	24.13	0	0
	836.5	20525	3	QPSK	8	0	22.96	0-1	1
	836.5	20525	3	QPSK	8	4	22.92	0-1	1
	836.5	20525	3	QPSK	8	7	22.92	0-1	1
	836.5	20525	3	QPSK	15	0	22.93	0-1	1
	836.5	20525	3	16-QAM	1	0	23.02	0-1	1
	836.5	20525	3	16-QAM	1	7	22.96	0-1	1
	836.5	20525	3	16-QAM	1	14	22.84	0-1	1
	836.5	20525	3	16-QAM	8	0	21.80	0-2	2
	836.5	20525	3	16-QAM	8	4	21.86	0-2	2
	836.5	20525	3	16-QAM	8	7	21.84	0-2	2
836.5	20525	3	16-QAM	15	0	21.85	0-2	2	
High	847.5	20635	3	QPSK	1	0	24.18	0	0
	847.5	20635	3	QPSK	1	7	24.16	0	0
	847.5	20635	3	QPSK	1	14	23.95	0	0
	847.5	20635	3	QPSK	8	0	23.01	0-1	1
	847.5	20635	3	QPSK	8	4	23.02	0-1	1
	847.5	20635	3	QPSK	8	7	23.06	0-1	1
	847.5	20635	3	QPSK	15	0	23.06	0-1	1
	847.5	20635	3	16-QAM	1	0	22.90	0-1	1
	847.5	20635	3	16-QAM	1	7	23.12	0-1	1
	847.5	20635	3	16-QAM	1	14	23.04	0-1	1
	847.5	20635	3	16-QAM	8	0	22.13	0-2	2
	847.5	20635	3	16-QAM	8	4	22.11	0-2	2
	847.5	20635	3	16-QAM	8	7	22.13	0-2	2
847.5	20635	3	16-QAM	15	0	22.10	0-2	2	

FCC ID: ZNFH636	 SAR EVALUATION REPORT 	Reviewed by: Quality Manager
Document S/N: 0Y1503170617.ZNF	Test Dates: 03/17/15 - 04/20/15	DUT Type: Portable Handset
Page 31 of 77		

**Table 9-8
LTE Band 5 (Cell) Conducted Powers - 1.4 MHz Bandwidth**

	Frequency [MHz]	Channel	Bandwidth [MHz]	Modulation	RB Size	RB Offset	Conducted Power [dBm]	MPR Allowed per 3GPP [dB]	MPR [dB]
Low	824.7	20407	1.4	QPSK	1	0	24.00	0	0
	824.7	20407	1.4	QPSK	1	2	24.17	0	0
	824.7	20407	1.4	QPSK	1	5	24.19	0	0
	824.7	20407	1.4	QPSK	3	0	24.01	0	0
	824.7	20407	1.4	QPSK	3	2	24.05	0	0
	824.7	20407	1.4	QPSK	3	3	24.06	0	0
	824.7	20407	1.4	QPSK	6	0	23.03	0-1	1
	824.7	20407	1.4	16-QAM	1	0	23.10	0-1	1
	824.7	20407	1.4	16-QAM	1	2	23.20	0-1	1
	824.7	20407	1.4	16-QAM	1	5	23.15	0-1	1
	824.7	20407	1.4	16-QAM	3	0	23.05	0-1	1
	824.7	20407	1.4	16-QAM	3	2	22.86	0-1	1
	824.7	20407	1.4	16-QAM	3	3	22.71	0-1	1
824.7	20407	1.4	16-QAM	6	0	21.75	0-2	2	
Mid	836.5	20525	1.4	QPSK	1	0	24.13	0	0
	836.5	20525	1.4	QPSK	1	2	24.20	0	0
	836.5	20525	1.4	QPSK	1	5	24.15	0	0
	836.5	20525	1.4	QPSK	3	0	24.10	0	0
	836.5	20525	1.4	QPSK	3	2	24.11	0	0
	836.5	20525	1.4	QPSK	3	3	24.02	0	0
	836.5	20525	1.4	QPSK	6	0	22.96	0-1	1
	836.5	20525	1.4	16-QAM	1	0	23.15	0-1	1
	836.5	20525	1.4	16-QAM	1	2	22.94	0-1	1
	836.5	20525	1.4	16-QAM	1	5	22.73	0-1	1
	836.5	20525	1.4	16-QAM	3	0	23.08	0-1	1
	836.5	20525	1.4	16-QAM	3	2	23.06	0-1	1
	836.5	20525	1.4	16-QAM	3	3	22.78	0-1	1
836.5	20525	1.4	16-QAM	6	0	21.65	0-2	2	
High	848.3	20643	1.4	QPSK	1	0	24.15	0	0
	848.3	20643	1.4	QPSK	1	2	24.06	0	0
	848.3	20643	1.4	QPSK	1	5	24.18	0	0
	848.3	20643	1.4	QPSK	3	0	24.14	0	0
	848.3	20643	1.4	QPSK	3	2	24.11	0	0
	848.3	20643	1.4	QPSK	3	3	23.98	0	0
	848.3	20643	1.4	QPSK	6	0	23.04	0-1	1
	848.3	20643	1.4	16-QAM	1	0	22.80	0-1	1
	848.3	20643	1.4	16-QAM	1	2	22.81	0-1	1
	848.3	20643	1.4	16-QAM	1	5	23.16	0-1	1
	848.3	20643	1.4	16-QAM	3	0	22.96	0-1	1
	848.3	20643	1.4	16-QAM	3	2	22.82	0-1	1
	848.3	20643	1.4	16-QAM	3	3	23.13	0-1	1
848.3	20643	1.4	16-QAM	6	0	21.65	0-2	2	

FCC ID: ZNFH636	 SAR EVALUATION REPORT 	Reviewed by: Quality Manager
Document S/N: 0Y1503170617.ZNF	Test Dates: 03/17/15 - 04/20/15	DUT Type: Portable Handset
© 2015 PCTEST Engineering Laboratory, Inc.		Page 32 of 77

9.3.3

LTE Band 4 (AWS)

Table 9-9
LTE Band 4 (AWS) Conducted Powers - 20 MHz Bandwidth

	Frequency [MHz]	Channel	Bandwidth [MHz]	Modulation	RB Size	RB Offset	Conducted Power [dBm]	MPR Allowed per 3GPP [dB]	MPR [dB]
Mid	1732.5	20175	20	QPSK	1	0	23.60	0	0
	1732.5	20175	20	QPSK	1	50	23.24	0	0
	1732.5	20175	20	QPSK	1	99	23.54	0	0
	1732.5	20175	20	QPSK	50	0	22.24	0-1	1
	1732.5	20175	20	QPSK	50	25	22.08	0-1	1
	1732.5	20175	20	QPSK	50	50	22.00	0-1	1
	1732.5	20175	20	QPSK	100	0	22.01	0-1	1
	1732.5	20175	20	16QAM	1	0	21.90	0-1	1
	1732.5	20175	20	16QAM	1	50	22.02	0-1	1
	1732.5	20175	20	16QAM	1	99	21.92	0-1	1
	1732.5	20175	20	16QAM	50	0	21.22	0-2	2
	1732.5	20175	20	16QAM	50	25	21.17	0-2	2
	1732.5	20175	20	16QAM	50	50	21.13	0-2	2
	1732.5	20175	20	16QAM	100	0	21.10	0-2	2

Note: LTE Band 4 (AWS) at 20 MHz bandwidth does not support three non-overlapping channels. Per KDB Publication 941225 D05v02r03, when a device supports overlapping channel assignment in a channel bandwidth configuration, the middle channel of the group of overlapping channels should be selected for testing.



FCC ID: ZNFH636			SAR EVALUATION REPORT		Reviewed by: Quality Manager
Document S/N: 0Y1503170617.ZNF	Test Dates: 03/17/15 - 04/20/15	DUT Type: Portable Handset		Page 33 of 77	

Table 9-10
LTE Band 4 (AWS) Conducted Powers - 15 MHz Bandwidth

	Frequency [MHz]	Channel	Bandwidth [MHz]	Modulation	RB Size	RB Offset	Conducted Power [dBm]	MPR Allowed per 3GPP [dB]	MPR [dB]
Low	1717.5	20025	15	QPSK	1	0	22.94	0	0
	1717.5	20025	15	QPSK	1	36	22.87	0	0
	1717.5	20025	15	QPSK	1	74	22.73	0	0
	1717.5	20025	15	QPSK	36	0	21.90	0-1	1
	1717.5	20025	15	QPSK	36	18	21.74	0-1	1
	1717.5	20025	15	QPSK	36	37	21.79	0-1	1
	1717.5	20025	15	QPSK	75	0	21.84	0-1	1
	1717.5	20025	15	16QAM	1	0	21.89	0-1	1
	1717.5	20025	15	16QAM	1	36	21.70	0-1	1
	1717.5	20025	15	16QAM	1	74	21.87	0-1	1
	1717.5	20025	15	16QAM	36	0	20.94	0-2	2
	1717.5	20025	15	16QAM	36	18	20.94	0-2	2
1717.5	20025	15	16QAM	36	37	20.83	0-2	2	
1717.5	20025	15	16QAM	75	0	20.98	0-2	2	
Mid	1732.5	20175	15	QPSK	1	0	22.92	0	0
	1732.5	20175	15	QPSK	1	36	22.79	0	0
	1732.5	20175	15	QPSK	1	74	22.72	0	0
	1732.5	20175	15	QPSK	36	0	21.92	0-1	1
	1732.5	20175	15	QPSK	36	18	21.74	0-1	1
	1732.5	20175	15	QPSK	36	37	21.76	0-1	1
	1732.5	20175	15	QPSK	75	0	21.81	0-1	1
	1732.5	20175	15	16QAM	1	0	21.89	0-1	1
	1732.5	20175	15	16QAM	1	36	21.71	0-1	1
	1732.5	20175	15	16QAM	1	74	21.79	0-1	1
	1732.5	20175	15	16QAM	36	0	20.87	0-2	2
	1732.5	20175	15	16QAM	36	18	20.97	0-2	2
1732.5	20175	15	16QAM	36	37	20.81	0-2	2	
1732.5	20175	15	16QAM	75	0	20.93	0-2	2	
High	1747.5	20325	15	QPSK	1	0	22.86	0	0
	1747.5	20325	15	QPSK	1	36	22.72	0	0
	1747.5	20325	15	QPSK	1	74	22.77	0	0
	1747.5	20325	15	QPSK	36	0	22.02	0-1	1
	1747.5	20325	15	QPSK	36	18	21.76	0-1	1
	1747.5	20325	15	QPSK	36	37	21.72	0-1	1
	1747.5	20325	15	QPSK	75	0	21.71	0-1	1
	1747.5	20325	15	16QAM	1	0	21.81	0-1	1
	1747.5	20325	15	16QAM	1	36	21.76	0-1	1
	1747.5	20325	15	16QAM	1	74	21.77	0-1	1
	1747.5	20325	15	16QAM	36	0	20.80	0-2	2
	1747.5	20325	15	16QAM	36	18	20.87	0-2	2
1747.5	20325	15	16QAM	36	37	20.84	0-2	2	
1747.5	20325	15	16QAM	75	0	20.88	0-2	2	



FCC ID: ZNFH636	 SAR EVALUATION REPORT 	Reviewed by: Quality Manager
Document S/N: 0Y1503170617.ZNF	Test Dates: 03/17/15 - 04/20/15	DUT Type: Portable Handset
Page 34 of 77		

Table 9-11
LTE Band 4 (AWS) Conducted Powers - 10 MHz Bandwidth

	Frequency [MHz]	Channel	Bandwidth [MHz]	Modulation	RB Size	RB Offset	Conducted Power [dBm]	MPR Allowed per 3GPP [dB]	MPR [dB]
Low	1715	20000	10	QPSK	1	0	23.03	0	0
	1715	20000	10	QPSK	1	25	22.93	0	0
	1715	20000	10	QPSK	1	49	22.72	0	0
	1715	20000	10	QPSK	25	0	21.97	0-1	1
	1715	20000	10	QPSK	25	12	21.78	0-1	1
	1715	20000	10	QPSK	25	25	21.85	0-1	1
	1715	20000	10	QPSK	50	0	21.91	0-1	1
	1715	20000	10	16QAM	1	0	21.83	0-1	1
	1715	20000	10	16QAM	1	25	21.77	0-1	1
	1715	20000	10	16QAM	1	49	21.97	0-1	1
	1715	20000	10	16QAM	25	0	20.96	0-2	2
	1715	20000	10	16QAM	25	12	20.88	0-2	2
	1715	20000	10	16QAM	25	25	20.84	0-2	2
1715	20000	10	16QAM	50	0	20.88	0-2	2	
Mid	1732.5	20175	10	QPSK	1	0	22.96	0	0
	1732.5	20175	10	QPSK	1	25	22.79	0	0
	1732.5	20175	10	QPSK	1	49	22.73	0	0
	1732.5	20175	10	QPSK	25	0	21.96	0-1	1
	1732.5	20175	10	QPSK	25	12	21.79	0-1	1
	1732.5	20175	10	QPSK	25	25	21.76	0-1	1
	1732.5	20175	10	QPSK	50	0	21.88	0-1	1
	1732.5	20175	10	16QAM	1	0	21.85	0-1	1
	1732.5	20175	10	16QAM	1	25	21.81	0-1	1
	1732.5	20175	10	16QAM	1	49	21.78	0-1	1
	1732.5	20175	10	16QAM	25	0	20.89	0-2	2
	1732.5	20175	10	16QAM	25	12	21.06	0-2	2
	1732.5	20175	10	16QAM	25	25	20.84	0-2	2
1732.5	20175	10	16QAM	50	0	20.97	0-2	2	
High	1750	20350	10	QPSK	1	0	22.86	0	0
	1750	20350	10	QPSK	1	25	22.78	0	0
	1750	20350	10	QPSK	1	49	22.77	0	0
	1750	20350	10	QPSK	25	0	22.05	0-1	1
	1750	20350	10	QPSK	25	12	21.71	0-1	1
	1750	20350	10	QPSK	25	25	21.79	0-1	1
	1750	20350	10	QPSK	50	0	21.78	0-1	1
	1750	20350	10	16QAM	1	0	21.84	0-1	1
	1750	20350	10	16QAM	1	25	21.80	0-1	1
	1750	20350	10	16QAM	1	49	21.71	0-1	1
	1750	20350	10	16QAM	25	0	20.82	0-2	2
	1750	20350	10	16QAM	25	12	20.78	0-2	2
	1750	20350	10	16QAM	25	25	20.90	0-2	2
1750	20350	10	16QAM	50	0	20.82	0-2	2	



FCC ID: ZNFH636		SAR EVALUATION REPORT		Reviewed by: Quality Manager
Document S/N: 0Y1503170617.ZNF	Test Dates: 03/17/15 - 04/20/15	DUT Type: Portable Handset		Page 35 of 77

Table 9-12
LTE Band 4 (AWS) Conducted Powers - 5 MHz Bandwidth

	Frequency [MHz]	Channel	Bandwidth [MHz]	Modulation	RB Size	RB Offset	Conducted Power [dBm]	MPR Allowed per 3GPP [dB]	MPR [dB]
Low	1712.5	19975	5	QPSK	1	0	22.96	0	0
	1712.5	19975	5	QPSK	1	12	22.94	0	0
	1712.5	19975	5	QPSK	1	24	22.77	0	0
	1712.5	19975	5	QPSK	12	0	21.90	0-1	1
	1712.5	19975	5	QPSK	12	6	21.78	0-1	1
	1712.5	19975	5	QPSK	12	13	21.85	0-1	1
	1712.5	19975	5	QPSK	25	0	21.92	0-1	1
	1712.5	19975	5	16-QAM	1	0	21.98	0-1	1
	1712.5	19975	5	16-QAM	1	12	21.78	0-1	1
	1712.5	19975	5	16-QAM	1	24	21.82	0-1	1
	1712.5	19975	5	16-QAM	12	0	21.03	0-2	2
	1712.5	19975	5	16-QAM	12	6	20.84	0-2	2
1712.5	19975	5	16-QAM	12	13	20.89	0-2	2	
1712.5	19975	5	16-QAM	25	0	21.04	0-2	2	
Mid	1732.5	20175	5	QPSK	1	0	22.96	0	0
	1732.5	20175	5	QPSK	1	12	22.86	0	0
	1732.5	20175	5	QPSK	1	24	22.80	0	0
	1732.5	20175	5	QPSK	12	0	21.98	0-1	1
	1732.5	20175	5	QPSK	12	6	21.79	0-1	1
	1732.5	20175	5	QPSK	12	13	21.76	0-1	1
	1732.5	20175	5	QPSK	25	0	21.85	0-1	1
	1732.5	20175	5	16-QAM	1	0	21.80	0-1	1
	1732.5	20175	5	16-QAM	1	12	21.76	0-1	1
	1732.5	20175	5	16-QAM	1	24	21.73	0-1	1
	1732.5	20175	5	16-QAM	12	0	20.85	0-2	2
	1732.5	20175	5	16-QAM	12	6	20.97	0-2	2
1732.5	20175	5	16-QAM	12	13	20.88	0-2	2	
1732.5	20175	5	16-QAM	25	0	21.01	0-2	2	
High	1752.5	20375	5	QPSK	1	0	22.95	0	0
	1752.5	20375	5	QPSK	1	12	22.77	0	0
	1752.5	20375	5	QPSK	1	24	22.71	0	0
	1752.5	20375	5	QPSK	12	0	22.08	0-1	1
	1752.5	20375	5	QPSK	12	6	21.73	0-1	1
	1752.5	20375	5	QPSK	12	13	21.72	0-1	1
	1752.5	20375	5	QPSK	25	0	21.76	0-1	1
	1752.5	20375	5	16-QAM	1	0	21.86	0-1	1
	1752.5	20375	5	16-QAM	1	12	21.74	0-1	1
	1752.5	20375	5	16-QAM	1	24	21.83	0-1	1
	1752.5	20375	5	16-QAM	12	0	20.81	0-2	2
	1752.5	20375	5	16-QAM	12	6	20.81	0-2	2
1752.5	20375	5	16-QAM	12	13	20.90	0-2	2	
1752.5	20375	5	16-QAM	25	0	20.84	0-2	2	





FCC ID: ZNFH636		SAR EVALUATION REPORT		Reviewed by: Quality Manager
Document S/N: 0Y1503170617.ZNF	Test Dates: 03/17/15 - 04/20/15	DUT Type: Portable Handset		Page 36 of 77



Table 9-13
LTE Band 4 (AWS) Conducted Powers - 3 MHz Bandwidth

	Frequency [MHz]	Channel	Bandwidth [MHz]	Modulation	RB Size	RB Offset	Conducted Power [dBm]	MPR Allowed per 3GPP [dB]	MPR [dB]
Low	1711.5	19965	3	QPSK	1	0	23.02	0	0
	1711.5	19965	3	QPSK	1	7	23.06	0	0
	1711.5	19965	3	QPSK	1	14	23.06	0	0
	1711.5	19965	3	QPSK	8	0	21.78	0-1	1
	1711.5	19965	3	QPSK	8	4	21.71	0-1	1
	1711.5	19965	3	QPSK	8	7	21.86	0-1	1
	1711.5	19965	3	QPSK	15	0	21.82	0-1	1
	1711.5	19965	3	16-QAM	1	0	21.76	0-1	1
	1711.5	19965	3	16-QAM	1	7	21.80	0-1	1
	1711.5	19965	3	16-QAM	1	14	22.06	0-1	1
	1711.5	19965	3	16-QAM	8	0	20.90	0-2	2
	1711.5	19965	3	16-QAM	8	4	20.97	0-2	2
1711.5	19965	3	16-QAM	8	7	20.85	0-2	2	
1711.5	19965	3	16-QAM	15	0	20.89	0-2	2	
Mid	1732.5	20175	3	QPSK	1	0	23.02	0	0
	1732.5	20175	3	QPSK	1	7	23.06	0	0
	1732.5	20175	3	QPSK	1	14	23.05	0	0
	1732.5	20175	3	QPSK	8	0	21.78	0-1	1
	1732.5	20175	3	QPSK	8	4	21.70	0-1	1
	1732.5	20175	3	QPSK	8	7	21.84	0-1	1
	1732.5	20175	3	QPSK	15	0	21.83	0-1	1
	1732.5	20175	3	16-QAM	1	0	21.80	0-1	1
	1732.5	20175	3	16-QAM	1	7	21.81	0-1	1
	1732.5	20175	3	16-QAM	1	14	22.09	0-1	1
	1732.5	20175	3	16-QAM	8	0	20.89	0-2	2
	1732.5	20175	3	16-QAM	8	4	21.01	0-2	2
1732.5	20175	3	16-QAM	8	7	20.82	0-2	2	
1732.5	20175	3	16-QAM	15	0	20.91	0-2	2	
High	1753.5	20385	3	QPSK	1	0	23.01	0	0
	1753.5	20385	3	QPSK	1	7	23.06	0	0
	1753.5	20385	3	QPSK	1	14	23.05	0	0
	1753.5	20385	3	QPSK	8	0	21.82	0-1	1
	1753.5	20385	3	QPSK	8	4	21.73	0-1	1
	1753.5	20385	3	QPSK	8	7	21.80	0-1	1
	1753.5	20385	3	QPSK	15	0	21.81	0-1	1
	1753.5	20385	3	16-QAM	1	0	21.80	0-1	1
	1753.5	20385	3	16-QAM	1	7	21.79	0-1	1
	1753.5	20385	3	16-QAM	1	14	22.09	0-1	1
	1753.5	20385	3	16-QAM	8	0	20.91	0-2	2
	1753.5	20385	3	16-QAM	8	4	21.01	0-2	2
1753.5	20385	3	16-QAM	8	7	20.80	0-2	2	
1753.5	20385	3	16-QAM	15	0	20.89	0-2	2	

FCC ID: ZNFH636	 SAR EVALUATION REPORT 	Reviewed by: Quality Manager
Document S/N: 0Y1503170617.ZNF	Test Dates: 03/17/15 - 04/20/15	DUT Type: Portable Handset
Page 37 of 77		

**Table 9-14
LTE Band 4 (AWS) Conducted Powers - 1.4 MHz Bandwidth**

	Frequency [MHz]	Channel	Bandwidth [MHz]	Modulation	RB Size	RB Offset	Conducted Power [dBm]	MPR Allowed per 3GPP [dB]	MPR [dB]
Low	1710.7	19957	1.4	QPSK	1	0	23.06	0	0
	1710.7	19957	1.4	QPSK	1	2	23.03	0	0
	1710.7	19957	1.4	QPSK	1	5	23.07	0	0
	1710.7	19957	1.4	QPSK	3	0	22.79	0	0
	1710.7	19957	1.4	QPSK	3	2	22.70	0	0
	1710.7	19957	1.4	QPSK	3	3	22.82	0	0
	1710.7	19957	1.4	QPSK	6	0	21.82	0-1	1
	1710.7	19957	1.4	16-QAM	1	0	21.84	0-1	1
	1710.7	19957	1.4	16-QAM	1	2	21.80	0-1	1
	1710.7	19957	1.4	16-QAM	1	5	22.11	0-1	1
	1710.7	19957	1.4	16-QAM	3	0	21.92	0-1	1
	1710.7	19957	1.4	16-QAM	3	2	21.98	0-1	1
	1710.7	19957	1.4	16-QAM	3	3	21.84	0-1	1
1710.7	19957	1.4	16-QAM	6	0	20.87	0-2	2	
Mid	1732.5	20175	1.4	QPSK	1	0	23.04	0	0
	1732.5	20175	1.4	QPSK	1	2	23.03	0	0
	1732.5	20175	1.4	QPSK	1	5	23.03	0	0
	1732.5	20175	1.4	QPSK	3	0	22.82	0	0
	1732.5	20175	1.4	QPSK	3	2	22.76	0	0
	1732.5	20175	1.4	QPSK	3	3	22.83	0	0
	1732.5	20175	1.4	QPSK	6	0	21.85	0-1	1
	1732.5	20175	1.4	16-QAM	1	0	21.82	0-1	1
	1732.5	20175	1.4	16-QAM	1	2	21.81	0-1	1
	1732.5	20175	1.4	16-QAM	1	5	22.07	0-1	1
	1732.5	20175	1.4	16-QAM	3	0	21.92	0-1	1
	1732.5	20175	1.4	16-QAM	3	2	21.99	0-1	1
	1732.5	20175	1.4	16-QAM	3	3	21.86	0-1	1
1732.5	20175	1.4	16-QAM	6	0	20.87	0-2	2	
High	1754.3	20393	1.4	QPSK	1	0	22.99	0	0
	1754.3	20393	1.4	QPSK	1	2	23.02	0	0
	1754.3	20393	1.4	QPSK	1	5	23.01	0	0
	1754.3	20393	1.4	QPSK	3	0	22.76	0	0
	1754.3	20393	1.4	QPSK	3	2	22.70	0	0
	1754.3	20393	1.4	QPSK	3	3	22.87	0	0
	1754.3	20393	1.4	QPSK	6	0	21.86	0-1	1
	1754.3	20393	1.4	16-QAM	1	0	21.77	0-1	1
	1754.3	20393	1.4	16-QAM	1	2	21.80	0-1	1
	1754.3	20393	1.4	16-QAM	1	5	22.09	0-1	1
	1754.3	20393	1.4	16-QAM	3	0	21.93	0-1	1
	1754.3	20393	1.4	16-QAM	3	2	21.98	0-1	1
	1754.3	20393	1.4	16-QAM	3	3	21.78	0-1	1
1754.3	20393	1.4	16-QAM	6	0	20.92	0-2	2	

FCC ID: ZNFH636	 SAR EVALUATION REPORT 	Reviewed by: Quality Manager
Document S/N: OY1503170617.ZNF	Test Dates: 03/17/15 - 04/20/15	DUT Type: Portable Handset
		Page 38 of 77

9.3.4

LTE Band 2 (PCS)

Table 9-15
LTE Band 2 (PCS) Conducted Powers - 20 MHz Bandwidth

	Frequency [MHz]	Channel	Bandwidth [MHz]	Modulation	RB Size	RB Offset	Conducted Power [dBm]	MPR Allowed per 3GPP [dB]	MPR [dB]
Low	1860	18700	20	QPSK	1	0	23.43	0	0
	1860	18700	20	QPSK	1	50	23.48	0	0
	1860	18700	20	QPSK	1	99	23.24	0	0
	1860	18700	20	QPSK	50	0	22.28	0-1	1
	1860	18700	20	QPSK	50	25	22.15	0-1	1
	1860	18700	20	QPSK	50	50	22.10	0-1	1
	1860	18700	20	QPSK	100	0	22.09	0-1	1
	1860	18700	20	16QAM	1	0	21.84	0-1	1
	1860	18700	20	16QAM	1	50	21.75	0-1	1
	1860	18700	20	16QAM	1	99	21.78	0-1	1
	1860	18700	20	16QAM	50	0	21.24	0-2	2
	1860	18700	20	16QAM	50	25	21.10	0-2	2
1860	18700	20	16QAM	50	50	21.11	0-2	2	
1860	18700	20	16QAM	100	0	21.02	0-2	2	
Mid	1880.0	18900	20	QPSK	1	0	23.46	0	0
	1880.0	18900	20	QPSK	1	50	23.33	0	0
	1880.0	18900	20	QPSK	1	99	23.54	0	0
	1880.0	18900	20	QPSK	50	0	22.16	0-1	1
	1880.0	18900	20	QPSK	50	25	22.04	0-1	1
	1880.0	18900	20	QPSK	50	50	21.98	0-1	1
	1880.0	18900	20	QPSK	100	0	22.03	0-1	1
	1880.0	18900	20	16QAM	1	0	22.15	0-1	1
	1880.0	18900	20	16QAM	1	50	22.16	0-1	1
	1880.0	18900	20	16QAM	1	99	22.00	0-1	1
	1880.0	18900	20	16QAM	50	0	21.16	0-2	2
	1880.0	18900	20	16QAM	50	25	21.10	0-2	2
1880.0	18900	20	16QAM	50	50	21.02	0-2	2	
1880.0	18900	20	16QAM	100	0	21.02	0-2	2	
High	1900	19100	20	QPSK	1	0	23.18	0	0
	1900	19100	20	QPSK	1	50	23.12	0	0
	1900	19100	20	QPSK	1	99	23.07	0	0
	1900	19100	20	QPSK	50	0	22.07	0-1	1
	1900	19100	20	QPSK	50	25	22.03	0-1	1
	1900	19100	20	QPSK	50	50	21.98	0-1	1
	1900	19100	20	QPSK	100	0	21.96	0-1	1
	1900	19100	20	16QAM	1	0	21.97	0-1	1
	1900	19100	20	16QAM	1	50	21.94	0-1	1
	1900	19100	20	16QAM	1	99	21.84	0-1	1
	1900	19100	20	16QAM	50	0	20.99	0-2	2
	1900	19100	20	16QAM	50	25	21.01	0-2	2
1900	19100	20	16QAM	50	50	20.94	0-2	2	
1900	19100	20	16QAM	100	0	21.05	0-2	2	



FCC ID: ZNFH636	 SAR EVALUATION REPORT 		Reviewed by: Quality Manager
Document S/N: 0Y1503170617.ZNF	Test Dates: 03/17/15 - 04/20/15	DUT Type: Portable Handset	Page 39 of 77

Table 9-16
LTE Band 2 (PCS) Conducted Powers - 15 MHz Bandwidth

	Frequency [MHz]	Channel	Bandwidth [MHz]	Modulation	RB Size	RB Offset	Conducted Power [dBm]	MPR Allowed per 3GPP [dB]	MPR [dB]
Low	1857.5	18675	15	QPSK	1	0	23.34	0	0
	1857.5	18675	15	QPSK	1	36	23.48	0	0
	1857.5	18675	15	QPSK	1	74	23.32	0	0
	1857.5	18675	15	QPSK	36	0	22.23	0-1	1
	1857.5	18675	15	QPSK	36	18	22.14	0-1	1
	1857.5	18675	15	QPSK	36	37	22.01	0-1	1
	1857.5	18675	15	QPSK	75	0	22.17	0-1	1
	1857.5	18675	15	16QAM	1	0	21.76	0-1	1
	1857.5	18675	15	16QAM	1	36	21.82	0-1	1
	1857.5	18675	15	16QAM	1	74	21.83	0-1	1
	1857.5	18675	15	16QAM	36	0	21.18	0-2	2
	1857.5	18675	15	16QAM	36	18	21.17	0-2	2
1857.5	18675	15	16QAM	36	37	21.11	0-2	2	
1857.5	18675	15	16QAM	75	0	21.05	0-2	2	
Mid	1880.0	18900	15	QPSK	1	0	23.43	0	0
	1880.0	18900	15	QPSK	1	36	23.40	0	0
	1880.0	18900	15	QPSK	1	74	23.56	0	0
	1880.0	18900	15	QPSK	36	0	22.20	0-1	1
	1880.0	18900	15	QPSK	36	18	22.03	0-1	1
	1880.0	18900	15	QPSK	36	37	21.97	0-1	1
	1880.0	18900	15	QPSK	75	0	22.01	0-1	1
	1880.0	18900	15	16QAM	1	0	22.12	0-1	1
	1880.0	18900	15	16QAM	1	36	22.25	0-1	1
	1880.0	18900	15	16QAM	1	74	21.91	0-1	1
	1880.0	18900	15	16QAM	36	0	21.08	0-2	2
	1880.0	18900	15	16QAM	36	18	21.04	0-2	2
1880.0	18900	15	16QAM	36	37	20.94	0-2	2	
1880.0	18900	15	16QAM	75	0	20.95	0-2	2	
High	1902.5	19125	15	QPSK	1	0	23.23	0	0
	1902.5	19125	15	QPSK	1	36	23.02	0	0
	1902.5	19125	15	QPSK	1	74	23.03	0	0
	1902.5	19125	15	QPSK	36	0	22.07	0-1	1
	1902.5	19125	15	QPSK	36	18	21.99	0-1	1
	1902.5	19125	15	QPSK	36	37	21.92	0-1	1
	1902.5	19125	15	QPSK	75	0	22.06	0-1	1
	1902.5	19125	15	16QAM	1	0	21.94	0-1	1
	1902.5	19125	15	16QAM	1	36	22.03	0-1	1
	1902.5	19125	15	16QAM	1	74	21.75	0-1	1
	1902.5	19125	15	16QAM	36	0	20.95	0-2	2
	1902.5	19125	15	16QAM	36	18	21.01	0-2	2
1902.5	19125	15	16QAM	36	37	20.85	0-2	2	
1902.5	19125	15	16QAM	75	0	20.98	0-2	2	



FCC ID: ZNFH636	 SAR EVALUATION REPORT 	Reviewed by: Quality Manager
Document S/N: 0Y1503170617.ZNF	Test Dates: 03/17/15 - 04/20/15	DUT Type: Portable Handset
Page 40 of 77		

Table 9-17
LTE Band 2 (PCS) Conducted Powers - 10 MHz Bandwidth

	Frequency [MHz]	Channel	Bandwidth [MHz]	Modulation	RB Size	RB Offset	Conducted Power [dBm]	MPR Allowed per 3GPP [dB]	MPR [dB]
Low	1855	18650	10	QPSK	1	0	23.51	0	0
	1855	18650	10	QPSK	1	25	23.51	0	0
	1855	18650	10	QPSK	1	49	23.19	0	0
	1855	18650	10	QPSK	25	0	22.25	0-1	1
	1855	18650	10	QPSK	25	12	22.20	0-1	1
	1855	18650	10	QPSK	25	25	22.13	0-1	1
	1855	18650	10	QPSK	50	0	22.09	0-1	1
	1855	18650	10	16QAM	1	0	21.75	0-1	1
	1855	18650	10	16QAM	1	25	21.71	0-1	1
	1855	18650	10	16QAM	1	49	21.73	0-1	1
	1855	18650	10	16QAM	25	0	21.21	0-2	2
	1855	18650	10	16QAM	25	12	21.17	0-2	2
Mid	1855	18650	10	16QAM	25	25	21.06	0-2	2
	1855	18650	10	16QAM	50	0	21.11	0-2	2
	1880.0	18900	10	QPSK	1	0	23.43	0	0
	1880.0	18900	10	QPSK	1	25	23.26	0	0
	1880.0	18900	10	QPSK	1	49	23.51	0	0
	1880.0	18900	10	QPSK	25	0	22.06	0-1	1
	1880.0	18900	10	QPSK	25	12	22.09	0-1	1
	1880.0	18900	10	QPSK	25	25	22.02	0-1	1
	1880.0	18900	10	QPSK	50	0	22.07	0-1	1
	1880.0	18900	10	16QAM	1	0	22.05	0-1	1
	1880.0	18900	10	16QAM	1	25	22.14	0-1	1
	1880.0	18900	10	16QAM	1	49	22.10	0-1	1
High	1880.0	18900	10	16QAM	25	0	21.17	0-2	2
	1880.0	18900	10	16QAM	25	12	21.02	0-2	2
	1880.0	18900	10	16QAM	25	25	21.02	0-2	2
	1880.0	18900	10	16QAM	50	0	20.92	0-2	2
	1905	19150	10	QPSK	1	0	23.09	0	0
	1905	19150	10	QPSK	1	25	23.05	0	0
	1905	19150	10	QPSK	1	49	23.14	0	0
	1905	19150	10	QPSK	25	0	22.09	0-1	1
	1905	19150	10	QPSK	25	12	21.97	0-1	1
	1905	19150	10	QPSK	25	25	21.93	0-1	1
	1905	19150	10	QPSK	50	0	21.94	0-1	1
	1905	19150	10	16QAM	1	0	22.04	0-1	1
1905	19150	10	16QAM	1	25	21.90	0-1	1	
1905	19150	10	16QAM	1	49	21.84	0-1	1	
1905	19150	10	16QAM	25	0	21.04	0-2	2	
1905	19150	10	16QAM	25	12	21.03	0-2	2	
1905	19150	10	16QAM	25	25	20.87	0-2	2	
1905	19150	10	16QAM	50	0	21.10	0-2	2	



FCC ID: ZNFH636		SAR EVALUATION REPORT		Reviewed by: Quality Manager
Document S/N: 0Y1503170617.ZNF	Test Dates: 03/17/15 - 04/20/15	DUT Type: Portable Handset		Page 41 of 77

Table 9-18
LTE Band 2 (PCS) Conducted Powers - 5 MHz Bandwidth

	Frequency [MHz]	Channel	Bandwidth [MHz]	Modulation	RB Size	RB Offset	Conducted Power [dBm]	MPR Allowed per 3GPP [dB]	MPR [dB]
Low	1852.5	18625	5	QPSK	1	0	23.33	0	0
	1852.5	18625	5	QPSK	1	12	23.55	0	0
	1852.5	18625	5	QPSK	1	24	23.24	0	0
	1852.5	18625	5	QPSK	12	0	22.29	0-1	1
	1852.5	18625	5	QPSK	12	6	22.24	0-1	1
	1852.5	18625	5	QPSK	12	13	22.13	0-1	1
	1852.5	18625	5	QPSK	25	0	22.04	0-1	1
	1852.5	18625	5	16-QAM	1	0	21.89	0-1	1
	1852.5	18625	5	16-QAM	1	12	21.77	0-1	1
	1852.5	18625	5	16-QAM	1	24	21.84	0-1	1
	1852.5	18625	5	16-QAM	12	0	21.34	0-2	2
	1852.5	18625	5	16-QAM	12	6	21.10	0-2	2
	1852.5	18625	5	16-QAM	12	13	21.09	0-2	2
1852.5	18625	5	16-QAM	25	0	21.12	0-2	2	
Mid	1880.0	18900	5	QPSK	1	0	23.56	0	0
	1880.0	18900	5	QPSK	1	12	23.23	0	0
	1880.0	18900	5	QPSK	1	24	23.64	0	0
	1880.0	18900	5	QPSK	12	0	22.20	0-1	1
	1880.0	18900	5	QPSK	12	6	22.11	0-1	1
	1880.0	18900	5	QPSK	12	13	22.07	0-1	1
	1880.0	18900	5	QPSK	25	0	22.06	0-1	1
	1880.0	18900	5	16-QAM	1	0	22.18	0-1	1
	1880.0	18900	5	16-QAM	1	12	22.22	0-1	1
	1880.0	18900	5	16-QAM	1	24	21.92	0-1	1
	1880.0	18900	5	16-QAM	12	0	21.09	0-2	2
	1880.0	18900	5	16-QAM	12	6	21.12	0-2	2
	1880.0	18900	5	16-QAM	12	13	21.07	0-2	2
1880.0	18900	5	16-QAM	25	0	21.12	0-2	2	
High	1907.5	19175	5	QPSK	1	0	23.27	0	0
	1907.5	19175	5	QPSK	1	12	23.11	0	0
	1907.5	19175	5	QPSK	1	24	23.05	0	0
	1907.5	19175	5	QPSK	12	0	22.01	0-1	1
	1907.5	19175	5	QPSK	12	6	22.12	0-1	1
	1907.5	19175	5	QPSK	12	13	21.94	0-1	1
	1907.5	19175	5	QPSK	25	0	22.02	0-1	1
	1907.5	19175	5	16-QAM	1	0	22.04	0-1	1
	1907.5	19175	5	16-QAM	1	12	22.04	0-1	1
	1907.5	19175	5	16-QAM	1	24	21.80	0-1	1
	1907.5	19175	5	16-QAM	12	0	21.08	0-2	2
	1907.5	19175	5	16-QAM	12	6	21.01	0-2	2
	1907.5	19175	5	16-QAM	12	13	20.88	0-2	2
1907.5	19175	5	16-QAM	25	0	21.09	0-2	2	



FCC ID: ZNFH636	 PCTEST <small>ENGINEERING LABORATORY, INC.</small>	SAR EVALUATION REPORT		Reviewed by: Quality Manager
Document S/N: 0Y1503170617.ZNF	Test Dates: 03/17/15 - 04/20/15	DUT Type: Portable Handset		Page 42 of 77

Table 9-19
LTE Band 2 (PCS) Conducted Powers - 3 MHz Bandwidth

	Frequency [MHz]	Channel	Bandwidth [MHz]	Modulation	RB Size	RB Offset	Conducted Power [dBm]	MPR Allowed per 3GPP [dB]	MPR [dB]
Low	1851.5	18615	3	QPSK	1	0	23.44	0	0
	1851.5	18615	3	QPSK	1	7	23.42	0	0
	1851.5	18615	3	QPSK	1	14	23.47	0	0
	1851.5	18615	3	QPSK	8	0	22.06	0-1	1
	1851.5	18615	3	QPSK	8	4	21.98	0-1	1
	1851.5	18615	3	QPSK	8	7	22.16	0-1	1
	1851.5	18615	3	QPSK	15	0	22.07	0-1	1
	1851.5	18615	3	16-QAM	1	0	22.30	0-1	1
	1851.5	18615	3	16-QAM	1	7	22.26	0-1	1
	1851.5	18615	3	16-QAM	1	14	22.24	0-1	1
	1851.5	18615	3	16-QAM	8	0	20.84	0-2	2
	1851.5	18615	3	16-QAM	8	4	21.01	0-2	2
	1851.5	18615	3	16-QAM	8	7	21.09	0-2	2
	1851.5	18615	3	16-QAM	15	0	20.83	0-2	2
Mid	1880.0	18900	3	QPSK	1	0	23.17	0	0
	1880.0	18900	3	QPSK	1	7	23.53	0	0
	1880.0	18900	3	QPSK	1	14	23.37	0	0
	1880.0	18900	3	QPSK	8	0	21.93	0-1	1
	1880.0	18900	3	QPSK	8	4	21.91	0-1	1
	1880.0	18900	3	QPSK	8	7	22.06	0-1	1
	1880.0	18900	3	QPSK	15	0	21.98	0-1	1
	1880.0	18900	3	16-QAM	1	0	21.96	0-1	1
	1880.0	18900	3	16-QAM	1	7	21.88	0-1	1
	1880.0	18900	3	16-QAM	1	14	21.92	0-1	1
	1880.0	18900	3	16-QAM	8	0	20.94	0-2	2
	1880.0	18900	3	16-QAM	8	4	21.17	0-2	2
	1880.0	18900	3	16-QAM	8	7	20.98	0-2	2
	1880.0	18900	3	16-QAM	15	0	20.76	0-2	2
High	1908.5	19185	3	QPSK	1	0	23.29	0	0
	1908.5	19185	3	QPSK	1	7	23.26	0	0
	1908.5	19185	3	QPSK	1	14	23.13	0	0
	1908.5	19185	3	QPSK	8	0	22.01	0-1	1
	1908.5	19185	3	QPSK	8	4	22.02	0-1	1
	1908.5	19185	3	QPSK	8	7	22.01	0-1	1
	1908.5	19185	3	QPSK	15	0	22.03	0-1	1
	1908.5	19185	3	16-QAM	1	0	21.75	0-1	1
	1908.5	19185	3	16-QAM	1	7	21.79	0-1	1
	1908.5	19185	3	16-QAM	1	14	21.91	0-1	1
	1908.5	19185	3	16-QAM	8	0	21.11	0-2	2
	1908.5	19185	3	16-QAM	8	4	21.12	0-2	2
	1908.5	19185	3	16-QAM	8	7	20.97	0-2	2
	1908.5	19185	3	16-QAM	15	0	20.95	0-2	2





FCC ID: ZNFH636	 SAR EVALUATION REPORT 	Reviewed by: Quality Manager
Document S/N: 0Y1503170617.ZNF	Test Dates: 03/17/15 - 04/20/15	DUT Type: Portable Handset
Page 43 of 77		

Table 9-20
LTE Band 2 (PCS) Conducted Powers - 1.4 MHz Bandwidth

	Frequency [MHz]	Channel	Bandwidth [MHz]	Modulation	RB Size	RB Offset	Conducted Power [dBm]	MPR Allowed per 3GPP [dB]	MPR [dB]
Low	1850.7	18607	1.4	QPSK	1	0	23.47	0	0
	1850.7	18607	1.4	QPSK	1	2	23.43	0	0
	1850.7	18607	1.4	QPSK	1	5	23.43	0	0
	1850.7	18607	1.4	QPSK	3	0	23.07	0	0
	1850.7	18607	1.4	QPSK	3	2	22.98	0	0
	1850.7	18607	1.4	QPSK	3	3	23.10	0	0
	1850.7	18607	1.4	QPSK	6	0	22.06	0-1	1
	1850.7	18607	1.4	16-QAM	1	0	22.13	0-1	1
	1850.7	18607	1.4	16-QAM	1	2	22.09	0-1	1
	1850.7	18607	1.4	16-QAM	1	5	22.03	0-1	1
	1850.7	18607	1.4	16-QAM	3	0	21.81	0-1	1
	1850.7	18607	1.4	16-QAM	3	2	22.03	0-1	1
	1850.7	18607	1.4	16-QAM	3	3	22.12	0-1	1
1850.7	18607	1.4	16-QAM	6	0	20.85	0-2	2	
Mid	1880.0	18900	1.4	QPSK	1	0	23.19	0	0
	1880.0	18900	1.4	QPSK	1	2	23.51	0	0
	1880.0	18900	1.4	QPSK	1	5	23.36	0	0
	1880.0	18900	1.4	QPSK	3	0	22.91	0	0
	1880.0	18900	1.4	QPSK	3	2	22.89	0	0
	1880.0	18900	1.4	QPSK	3	3	23.08	0	0
	1880.0	18900	1.4	QPSK	6	0	21.99	0-1	1
	1880.0	18900	1.4	16-QAM	1	0	21.92	0-1	1
	1880.0	18900	1.4	16-QAM	1	2	21.87	0-1	1
	1880.0	18900	1.4	16-QAM	1	5	21.90	0-1	1
	1880.0	18900	1.4	16-QAM	3	0	21.97	0-1	1
	1880.0	18900	1.4	16-QAM	3	2	22.13	0-1	1
	1880.0	18900	1.4	16-QAM	3	3	21.97	0-1	1
1880.0	18900	1.4	16-QAM	6	0	20.78	0-2	2	
High	1909.3	19193	1.4	QPSK	1	0	23.30	0	0
	1909.3	19193	1.4	QPSK	1	2	23.27	0	0
	1909.3	19193	1.4	QPSK	1	5	23.17	0	0
	1909.3	19193	1.4	QPSK	3	0	23.05	0	0
	1909.3	19193	1.4	QPSK	3	2	22.99	0	0
	1909.3	19193	1.4	QPSK	3	3	22.98	0	0
	1909.3	19193	1.4	QPSK	6	0	21.99	0-1	1
	1909.3	19193	1.4	16-QAM	1	0	21.75	0-1	1
	1909.3	19193	1.4	16-QAM	1	2	21.82	0-1	1
	1909.3	19193	1.4	16-QAM	1	5	21.88	0-1	1
	1909.3	19193	1.4	16-QAM	3	0	22.08	0-1	1
	1909.3	19193	1.4	16-QAM	3	2	22.15	0-1	1
	1909.3	19193	1.4	16-QAM	3	3	21.98	0-1	1
1909.3	19193	1.4	16-QAM	6	0	20.92	0-2	2	



FCC ID: ZNFH636		SAR EVALUATION REPORT		Reviewed by: Quality Manager
Document S/N: 0Y1503170617.ZNF	Test Dates: 03/17/15 - 04/20/15	DUT Type: Portable Handset		Page 44 of 77

9.3.5

LTE Band 7

Table 9-21
LTE Band 7 Conducted Powers - 20 MHz Bandwidth

	Frequency [MHz]	Channel	Bandwidth [MHz]	Modulation	RB Size	RB Offset	Conducted Power [dBm]	MPR Allowed per 3GPP [dB]	MPR [dB]
Low	2510	20850	20	QPSK	1	0	23.24	0	0
	2510	20850	20	QPSK	1	50	23.35	0	0
	2510	20850	20	QPSK	1	99	23.11	0	0
	2510	20850	20	QPSK	50	0	21.89	0-1	1
	2510	20850	20	QPSK	50	25	21.87	0-1	1
	2510	20850	20	QPSK	50	50	21.84	0-1	1
	2510	20850	20	QPSK	100	0	21.87	0-1	1
	2510	20850	20	16QAM	1	0	21.79	0-1	1
	2510	20850	20	16QAM	1	50	21.91	0-1	1
	2510	20850	20	16QAM	1	99	21.71	0-1	1
	2510	20850	20	16QAM	50	0	20.85	0-2	2
	2510	20850	20	16QAM	50	25	20.83	0-2	2
	2510	20850	20	16QAM	50	50	20.79	0-2	2
	2510	20850	20	16QAM	100	0	20.89	0-2	2
Mid	2535.0	21100	20	QPSK	1	0	23.17	0	0
	2535.0	21100	20	QPSK	1	50	23.15	0	0
	2535.0	21100	20	QPSK	1	99	23.11	0	0
	2535.0	21100	20	QPSK	50	0	21.79	0-1	1
	2535.0	21100	20	QPSK	50	25	21.78	0-1	1
	2535.0	21100	20	QPSK	50	50	21.70	0-1	1
	2535.0	21100	20	QPSK	100	0	21.78	0-1	1
	2535.0	21100	20	16QAM	1	0	22.28	0-1	1
	2535.0	21100	20	16QAM	1	50	22.26	0-1	1
	2535.0	21100	20	16QAM	1	99	22.20	0-1	1
	2535.0	21100	20	16QAM	50	0	21.03	0-2	2
	2535.0	21100	20	16QAM	50	25	21.00	0-2	2
	2535.0	21100	20	16QAM	50	50	21.02	0-2	2
	2535.0	21100	20	16QAM	100	0	20.80	0-2	2
High	2560	21350	20	QPSK	1	0	23.31	0	0
	2560	21350	20	QPSK	1	50	23.34	0	0
	2560	21350	20	QPSK	1	99	23.14	0	0
	2560	21350	20	QPSK	50	0	21.82	0-1	1
	2560	21350	20	QPSK	50	25	21.83	0-1	1
	2560	21350	20	QPSK	50	50	21.70	0-1	1
	2560	21350	20	QPSK	100	0	21.74	0-1	1
	2560	21350	20	16QAM	1	0	21.92	0-1	1
	2560	21350	20	16QAM	1	50	21.95	0-1	1
	2560	21350	20	16QAM	1	99	21.70	0-1	1
	2560	21350	20	16QAM	50	0	20.77	0-2	2
	2560	21350	20	16QAM	50	25	20.87	0-2	2
	2560	21350	20	16QAM	50	50	20.73	0-2	2
	2560	21350	20	16QAM	100	0	20.89	0-2	2

FCC ID: ZNFH636	 SAR EVALUATION REPORT 		Reviewed by: Quality Manager
Document S/N: 0Y1503170617.ZNF	Test Dates: 03/17/15 - 04/20/15	DUT Type: Portable Handset	Page 45 of 77

**Table 9-22
LTE Band 7 Conducted Powers - 15 MHz Bandwidth**

	Frequency [MHz]	Channel	Bandwidth [MHz]	Modulation	RB Size	RB Offset	Conducted Power [dBm]	MPR Allowed per 3GPP [dB]	MPR [dB]
Low	2507.5	20825	15	QPSK	1	0	22.83	0	0
	2507.5	20825	15	QPSK	1	36	22.93	0	0
	2507.5	20825	15	QPSK	1	74	23.08	0	0
	2507.5	20825	15	QPSK	36	0	21.91	0-1	1
	2507.5	20825	15	QPSK	36	18	21.89	0-1	1
	2507.5	20825	15	QPSK	36	37	21.88	0-1	1
	2507.5	20825	15	QPSK	75	0	21.93	0-1	1
	2507.5	20825	15	16QAM	1	0	22.35	0-1	1
	2507.5	20825	15	16QAM	1	36	22.05	0-1	1
	2507.5	20825	15	16QAM	1	74	22.13	0-1	1
	2507.5	20825	15	16QAM	36	0	21.01	0-2	2
	2507.5	20825	15	16QAM	36	18	20.88	0-2	2
	2507.5	20825	15	16QAM	36	37	20.97	0-2	2
2507.5	20825	15	16QAM	75	0	20.87	0-2	2	
Mid	2535.0	21100	15	QPSK	1	0	23.20	0	0
	2535.0	21100	15	QPSK	1	36	23.09	0	0
	2535.0	21100	15	QPSK	1	74	23.22	0	0
	2535.0	21100	15	QPSK	36	0	21.88	0-1	1
	2535.0	21100	15	QPSK	36	18	21.79	0-1	1
	2535.0	21100	15	QPSK	36	37	21.78	0-1	1
	2535.0	21100	15	QPSK	75	0	21.88	0-1	1
	2535.0	21100	15	16QAM	1	0	21.90	0-1	1
	2535.0	21100	15	16QAM	1	36	21.76	0-1	1
	2535.0	21100	15	16QAM	1	74	21.80	0-1	1
	2535.0	21100	15	16QAM	36	0	20.75	0-2	2
	2535.0	21100	15	16QAM	36	18	20.71	0-2	2
	2535.0	21100	15	16QAM	36	37	20.73	0-2	2
2535.0	21100	15	16QAM	75	0	20.92	0-2	2	
High	2562.5	21375	15	QPSK	1	0	23.10	0	0
	2562.5	21375	15	QPSK	1	36	22.97	0	0
	2562.5	21375	15	QPSK	1	74	23.03	0	0
	2562.5	21375	15	QPSK	36	0	21.82	0-1	1
	2562.5	21375	15	QPSK	36	18	21.81	0-1	1
	2562.5	21375	15	QPSK	36	37	21.74	0-1	1
	2562.5	21375	15	QPSK	75	0	21.83	0-1	1
	2562.5	21375	15	16QAM	1	0	22.27	0-1	1
	2562.5	21375	15	16QAM	1	36	22.07	0-1	1
	2562.5	21375	15	16QAM	1	74	22.09	0-1	1
	2562.5	21375	15	16QAM	36	0	20.85	0-2	2
	2562.5	21375	15	16QAM	36	18	20.83	0-2	2
	2562.5	21375	15	16QAM	36	37	20.71	0-2	2
2562.5	21375	15	16QAM	75	0	20.81	0-2	2	





FCC ID: ZNFH636	 PCTEST <small>ENGINEERING LABORATORY, INC.</small>	SAR EVALUATION REPORT		Reviewed by: Quality Manager
Document S/N: 0Y1503170617.ZNF	Test Dates: 03/17/15 - 04/20/15	DUT Type: Portable Handset		Page 46 of 77



Table 9-23
LTE Band 7 Conducted Powers - 10 MHz Bandwidth

	Frequency [MHz]	Channel	Bandwidth [MHz]	Modulation	RB Size	RB Offset	Conducted Power [dBm]	MPR Allowed per 3GPP [dB]	MPR [dB]
Low	2505	20800	10	QPSK	1	0	23.02	0	0
	2505	20800	10	QPSK	1	25	22.71	0	0
	2505	20800	10	QPSK	1	49	22.95	0	0
	2505	20800	10	QPSK	25	0	21.81	0-1	1
	2505	20800	10	QPSK	25	12	21.80	0-1	1
	2505	20800	10	QPSK	25	25	21.82	0-1	1
	2505	20800	10	QPSK	50	0	21.77	0-1	1
	2505	20800	10	16QAM	1	0	21.81	0-1	1
	2505	20800	10	16QAM	1	25	21.94	0-1	1
	2505	20800	10	16QAM	1	49	21.85	0-1	1
	2505	20800	10	16QAM	25	0	20.93	0-2	2
	2505	20800	10	16QAM	25	12	20.95	0-2	2
Mid	2505	20800	10	16QAM	25	25	20.95	0-2	2
	2505	20800	10	16QAM	50	0	20.92	0-2	2
	2535.0	21100	10	QPSK	1	0	22.98	0	0
	2535.0	21100	10	QPSK	1	25	22.84	0	0
	2535.0	21100	10	QPSK	1	49	22.79	0	0
	2535.0	21100	10	QPSK	25	0	21.83	0-1	1
	2535.0	21100	10	QPSK	25	12	21.76	0-1	1
	2535.0	21100	10	QPSK	25	25	21.81	0-1	1
	2535.0	21100	10	QPSK	50	0	21.90	0-1	1
	2535.0	21100	10	16QAM	1	0	21.77	0-1	1
	2535.0	21100	10	16QAM	1	25	21.99	0-1	1
	2535.0	21100	10	16QAM	1	49	21.76	0-1	1
High	2535.0	21100	10	16QAM	25	0	21.06	0-2	2
	2535.0	21100	10	16QAM	25	12	20.98	0-2	2
	2535.0	21100	10	16QAM	25	25	20.92	0-2	2
	2535.0	21100	10	16QAM	50	0	20.81	0-2	2
	2565	21400	10	QPSK	1	0	22.89	0	0
	2565	21400	10	QPSK	1	25	22.81	0	0
	2565	21400	10	QPSK	1	49	22.77	0	0
	2565	21400	10	QPSK	25	0	21.78	0-1	1
	2565	21400	10	QPSK	25	12	21.77	0-1	1
	2565	21400	10	QPSK	25	25	21.72	0-1	1
	2565	21400	10	QPSK	50	0	21.73	0-1	1
	2565	21400	10	16QAM	1	0	22.09	0-1	1
2565	21400	10	16QAM	1	25	22.15	0-1	1	
2565	21400	10	16QAM	1	49	21.73	0-1	1	
2565	21400	10	16QAM	25	0	20.82	0-2	2	
2565	21400	10	16QAM	25	12	20.70	0-2	2	
2565	21400	10	16QAM	25	25	20.74	0-2	2	
2565	21400	10	16QAM	50	0	20.72	0-2	2	

FCC ID: ZNFH636		SAR EVALUATION REPORT		Reviewed by: Quality Manager
Document S/N: 0Y1503170617.ZNF	Test Dates: 03/17/15 - 04/20/15	DUT Type: Portable Handset		Page 47 of 77

**Table 9-24
LTE Band 7 Conducted Powers - 5 MHz Bandwidth**

	Frequency [MHz]	Channel	Bandwidth [MHz]	Modulation	RB Size	RB Offset	Conducted Power [dBm]	MPR Allowed per 3GPP [dB]	MPR [dB]
Low	2502.5	20775	5	QPSK	1	0	22.95	0	0
	2502.5	20775	5	QPSK	1	12	22.87	0	0
	2502.5	20775	5	QPSK	1	24	22.82	0	0
	2502.5	20775	5	QPSK	12	0	21.83	0-1	1
	2502.5	20775	5	QPSK	12	6	21.76	0-1	1
	2502.5	20775	5	QPSK	12	13	21.74	0-1	1
	2502.5	20775	5	QPSK	25	0	21.72	0-1	1
	2502.5	20775	5	16-QAM	1	0	22.28	0-1	1
	2502.5	20775	5	16-QAM	1	12	21.71	0-1	1
	2502.5	20775	5	16-QAM	1	24	21.97	0-1	1
	2502.5	20775	5	16-QAM	12	0	20.77	0-2	2
	2502.5	20775	5	16-QAM	12	6	20.89	0-2	2
	2502.5	20775	5	16-QAM	12	13	20.83	0-2	2
	2502.5	20775	5	16-QAM	25	0	20.88	0-2	2
Mid	2535.0	21100	5	QPSK	1	0	22.97	0	0
	2535.0	21100	5	QPSK	1	12	22.93	0	0
	2535.0	21100	5	QPSK	1	24	22.94	0	0
	2535.0	21100	5	QPSK	12	0	21.93	0-1	1
	2535.0	21100	5	QPSK	12	6	21.84	0-1	1
	2535.0	21100	5	QPSK	12	13	21.83	0-1	1
	2535.0	21100	5	QPSK	25	0	21.77	0-1	1
	2535.0	21100	5	16-QAM	1	0	21.90	0-1	1
	2535.0	21100	5	16-QAM	1	12	21.99	0-1	1
	2535.0	21100	5	16-QAM	1	24	21.81	0-1	1
	2535.0	21100	5	16-QAM	12	0	20.74	0-2	2
	2535.0	21100	5	16-QAM	12	6	20.79	0-2	2
	2535.0	21100	5	16-QAM	12	13	20.90	0-2	2
	2535.0	21100	5	16-QAM	25	0	20.84	0-2	2
High	2567.5	21425	5	QPSK	1	0	22.79	0	0
	2567.5	21425	5	QPSK	1	12	22.90	0	0
	2567.5	21425	5	QPSK	1	24	22.78	0	0
	2567.5	21425	5	QPSK	12	0	21.71	0-1	1
	2567.5	21425	5	QPSK	12	6	21.72	0-1	1
	2567.5	21425	5	QPSK	12	13	21.75	0-1	1
	2567.5	21425	5	QPSK	25	0	21.73	0-1	1
	2567.5	21425	5	16-QAM	1	0	22.58	0-1	1
	2567.5	21425	5	16-QAM	1	12	22.41	0-1	1
	2567.5	21425	5	16-QAM	1	24	22.24	0-1	1
	2567.5	21425	5	16-QAM	12	0	20.86	0-2	2
	2567.5	21425	5	16-QAM	12	6	20.78	0-2	2
	2567.5	21425	5	16-QAM	12	13	20.73	0-2	2
	2567.5	21425	5	16-QAM	25	0	20.80	0-2	2

FCC ID: ZNFH636		SAR EVALUATION REPORT		Reviewed by: Quality Manager
Document S/N: 0Y1503170617.ZNF	Test Dates: 03/17/15 - 04/20/15	DUT Type: Portable Handset		Page 48 of 77

9.4 WLAN Conducted Powers

Table 9-25
IEEE 802.11b Average RF Power

Freq [MHz]	Channel	2.4 GHz Conducted Power [dBm]
		IEEE Transmission Mode
		802.11b
2412	1	15.58
2437	6	15.98
2462	11	15.81

Table 9-26
IEEE 802.11g Average RF Power



Freq [MHz]	Channel	2.4 GHz Conducted Power [dBm]
		IEEE Transmission Mode
		802.11g
2412	1	13.59
2437	6	14.19
2462	11	14.61

Table 9-27
IEEE 802.11n Average RF Power

Freq [MHz]	Channel	2.4 GHz Conducted Power [dBm]
		IEEE Transmission Mode
		802.11n
2412	1	13.76
2437	6	14.27
2462	11	14.45

Table 9-28
5 GHz (40 MHz Bandwidth) Average RF Power

Freq [MHz]	Channel	40MHz BW 802.11n (5GHz) Conducted Power [dBm]
		Data Rate [Mbps]
		13.5
5190	38	14.06
5230	46	13.79
5270	54	14.01
5310	62	13.96
5510	102	13.95
5550	110	13.92
5590	118	N/A
5630	126	N/A
5670	134	13.70
5755	151	13.65
5795	159	13.92

FCC ID: ZNFH636	 PCTEST ENGINEERING LABORATORY, INC.	SAR EVALUATION REPORT	 LG	Reviewed by: Quality Manager
Document S/N: 0Y1503170617.ZNF	Test Dates: 03/17/15 - 04/20/15	DUT Type: Portable Handset	Page 49 of 77	

Justification for reduced test configurations for WIFI channels per KDB Publication 248227 D01v02:

- Power measurements were performed for the transmission mode configuration with the highest maximum output power specified for production units.
- For transmission modes with the same maximum output power specification, powers were measured for the largest channel bandwidth, lowest order modulation and lowest data rate.
- For transmission modes with identical maximum specified output power, channel bandwidth, modulation and data rates, power measurements were required for all identical configurations.
- For each transmission mode configuration, powers were measured for the highest and lowest channels; and at the mid-band channel(s) when there were at least 3 channels supported. For configurations with multiple mid-band channels, due to an even number of channels, both channels were measured.
- The bolded data rate and channel above were tested for SAR.

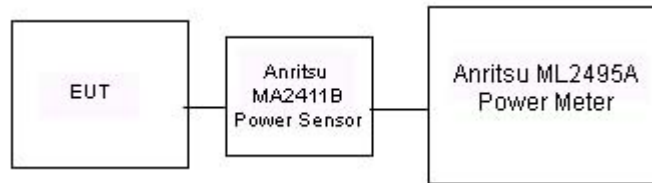

Figure 9-3
Power Measurement Setup

9.5 Bluetooth Conducted Powers

Table 9-29
Bluetooth RF Conducted Powers

Frequency [MHz]	Data Rate [Mbps]	Channel No.	Avg Conducted Power	
			[dBm]	[mW]
2402	1.0	0	7.76	5.966
2441	1.0	39	9.40	8.709
2480	1.0	78	8.28	6.736
2402	2.0	0	5.32	3.404
2441	2.0	39	6.93	4.930
2480	2.0	78	5.79	3.794
2402	3.0	0	5.34	3.416
2441	3.0	39	6.94	4.946
2480	3.0	78	5.83	3.824

Notes:

- The bolded data rate and channel above were tested for SAR.
- Bluetooth 1g body-worn and 10g extremity SAR was evaluated per manufacturer's request.

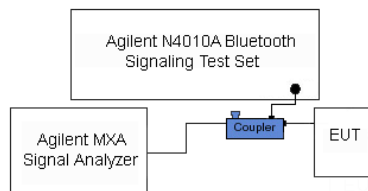



Figure 9-4
Power Measurement Setup



FCC ID: ZNFH636	 SAR EVALUATION REPORT 		Reviewed by: Quality Manager
Document S/N: 0Y1503170617.ZNF	Test Dates: 03/17/15 - 04/20/15	DUT Type: Portable Handset	Page 50 of 77

10 SYSTEM VERIFICATION

10.1 Tissue Verification

**Table 10-1
Measured Head Tissue Properties**



Calibrated for Tests Performed on:	Tissue Type	Tissue Temp During Calibration (C°)	Measured Frequency (MHz)	Measured Conductivity, σ (S/m)	Measured Dielectric Constant, ϵ	TARGET Conductivity, σ (S/m)	TARGET Dielectric Constant, ϵ	% dev σ	% dev ϵ
03/25/2015	750H	21.8	695	0.855	41.707	0.889	42.227	-3.82%	-1.23%
			710	0.87	41.474	0.890	42.149	-2.25%	-1.60%
			725	0.883	41.277	0.891	42.071	-0.90%	-1.89%
			740	0.898	41.103	0.893	41.994	0.56%	-2.12%
			755	0.911	40.903	0.894	41.916	1.90%	-2.42%
03/25/2015	835H	22.0	820	0.885	40.469	0.899	41.578	-1.56%	-2.67%
			835	0.899	40.279	0.900	41.500	-0.11%	-2.94%
			850	0.913	40.097	0.916	41.500	-0.33%	-3.38%
03/23/2015	1750H	20.4	1710	1.365	38.761	1.348	40.142	1.26%	-3.44%
			1750	1.409	38.615	1.371	40.079	2.77%	-3.65%
			1790	1.444	38.393	1.394	40.016	3.59%	-4.06%
03/23/2015	1900H	21.6	1850	1.379	40.155	1.400	40.000	-1.50%	0.39%
			1880	1.409	40.048	1.400	40.000	0.64%	0.12%
			1910	1.443	39.906	1.400	40.000	3.07%	-0.24%
03/23/2015	2450H	21.4	2401	1.776	39.180	1.756	39.287	1.14%	-0.27%
			2450	1.829	38.982	1.800	39.200	1.61%	-0.56%
			2499	1.884	38.812	1.853	39.138	1.67%	-0.83%
			2500	1.883	38.810	1.855	39.136	1.51%	-0.83%
			2550	1.943	38.638	1.909	39.073	1.78%	-1.11%
			2600	1.998	38.444	1.964	39.009	1.73%	-1.45%
03/26/2015	5200H-5800H	21.1	5260	4.649	36.728	4.717	35.917	-1.44%	2.26%
			5280	4.664	36.688	4.737	35.894	-1.54%	2.21%
			5300	4.691	36.654	4.758	35.871	-1.41%	2.18%
			5500	4.868	36.398	4.963	35.643	-1.91%	2.12%
			5520	4.900	36.361	4.983	35.620	-1.67%	2.08%
			5785	5.184	35.960	5.255	35.317	-1.35%	1.82%
			5800	5.201	35.955	5.270	35.300	-1.31%	1.86%

FCC ID: ZNFH636	 SAR EVALUATION REPORT 		Reviewed by: Quality Manager
Document S/N: 0Y1503170617.ZNF	Test Dates: 03/17/15 - 04/20/15	DUT Type: Portable Handset	Page 51 of 77

**Table 10-2
Measured Body Tissue Properties**

Calibrated for Tests Performed on:	Tissue Type	Tissue Temp During Calibration (C°)	Measured Frequency (MHz)	Measured Conductivity, σ (S/m)	Measured Dielectric Constant, ϵ	TARGET Conductivity, σ (S/m)	TARGET Dielectric Constant, ϵ	% dev σ	% dev ϵ
03/24/2015	750B	22.1	695	0.924	55.511	0.959	55.745	-3.65%	-0.42%
			710	0.936	55.316	0.960	55.687	-2.50%	-0.67%
			725	0.950	55.208	0.961	55.629	-1.14%	-0.76%
			740	0.965	55.021	0.963	55.570	0.21%	-0.99%
			755	0.977	54.880	0.964	55.512	1.35%	-1.14%
03/19/2015	835B	22.0	820	0.945	53.089	0.969	55.258	-2.48%	-3.93%
			835	0.961	52.937	0.970	55.200	-0.93%	-4.10%
			850	0.978	52.768	0.988	55.154	-1.01%	-4.33%
03/23/2015	835B	21.4	820	0.922	53.160	0.969	55.258	-4.85%	-3.80%
			835	0.936	53.015	0.970	55.200	-3.51%	-3.96%
			850	0.952	52.891	0.988	55.154	-3.64%	-4.10%
03/25/2015	1750B	21.4	1710	1.471	53.041	1.463	53.537	0.55%	-0.93%
			1750	1.518	52.874	1.488	53.432	2.02%	-1.04%
			1790	1.565	52.723	1.514	53.326	3.37%	-1.13%
03/23/2015	1900B	21.7	1850	1.506	52.078	1.520	53.300	-0.92%	-2.29%
			1880	1.537	51.957	1.520	53.300	1.12%	-2.52%
			1910	1.575	51.822	1.520	53.300	3.62%	-2.77%
03/17/2015	2450B	22.4	2401	1.958	50.991	1.903	52.765	2.89%	-3.36%
			2450	2.028	50.797	1.950	52.700	4.00%	-3.61%
			2499	2.089	50.607	2.019	52.638	3.47%	-3.86%
			2500	2.091	50.607	2.021	52.636	3.46%	-3.85%
			2550	2.159	50.405	2.092	52.573	3.20%	-4.12%
			2600	2.228	50.192	2.163	52.509	3.01%	-4.41%
03/25/2015	2450B	21.2	2401	1.973	51.277	1.903	52.765	3.68%	-2.82%
			2450	2.041	51.077	1.950	52.700	4.67%	-3.08%
			2499	2.104	50.901	2.019	52.638	4.21%	-3.30%
			2500	2.104	50.891	2.021	52.636	4.11%	-3.32%
			2550	2.176	50.719	2.092	52.573	4.02%	-3.53%
04/20/2015	2450B	22.5	2600	2.247	50.520	2.163	52.509	3.88%	-3.79%
			2401	1.976	50.935	1.903	52.765	3.84%	-3.47%
			2450	2.041	50.778	1.950	52.700	4.67%	-3.65%
03/31/2015	5200B-5800B	20.7	2499	2.107	50.579	2.019	52.638	4.36%	-3.91%
			5260	5.368	46.978	5.369	48.933	-0.02%	-4.00%
			5280	5.398	46.941	5.393	48.906	0.09%	-4.02%
			5300	5.420	46.896	5.416	48.879	0.07%	-4.06%
			5500	5.695	46.548	5.650	48.607	0.80%	-4.24%
			5520	5.719	46.498	5.673	48.580	0.81%	-4.29%
			5785	6.044	46.139	5.982	48.220	1.04%	-4.32%
			5800	6.065	46.114	6.000	48.200	1.08%	-4.33%

The above measured tissue parameters were used in the DASY software. The DASY software was used to perform interpolation to determine the dielectric parameters at the SAR test device frequencies (per KDB Publication 865664 and IEEE 1528-2013 6.6.1.2). The tissue parameters listed in the SAR test plots may slightly differ from the table above due to significant digit rounding in the software.



FCC ID: ZNFH636		SAR EVALUATION REPORT		Reviewed by: Quality Manager
Document S/N: 0Y1503170617.ZNF	Test Dates: 03/17/15 - 04/20/15	DUT Type: Portable Handset		Page 52 of 77

10.2 Test System Verification

Prior to SAR assessment, the system is verified to $\pm 10\%$ of the SAR measurement on the reference dipole at the time of calibration by the calibration facility. Full system validation status and result summary can be found in Appendix E.

Table 10-3
System Verification Results – 1 g

System Verification TARGET & MEASURED												
SAR System #	Tissue Frequency (MHz)	Tissue Type	Date:	Amb. Temp (°C)	Liquid Temp (°C)	Input Power (W)	Dipole SN	Probe SN	Measured SAR _{1g} (W/kg)	1 W Target SAR _{1g} (W/kg)	1 W Normalized SAR _{1g} (W/kg)	Deviation _{1g} (%)
J	750	HEAD	03/25/2015	22.9	21.8	0.100	1003	3022	0.856	8.090	8.560	5.81%
K	835	HEAD	03/25/2015	22.8	22.0	0.100	4d133	3288	0.945	9.200	9.450	2.72%
B	1750	HEAD	03/23/2015	23.4	20.4	0.100	1051	3334	3.860	36.200	38.600	6.63%
G	1900	HEAD	03/23/2015	22.6	21.6	0.100	5d141	3213	4.240	40.100	42.400	5.74%
K	2450	HEAD	03/23/2015	23.1	21.4	0.100	719	3288	5.590	52.100	55.900	7.29%
H	5300	HEAD	03/26/2015	22.6	21.0	0.050	1057	3920	4.060	84.700	81.200	-4.13%
H	5500	HEAD	03/26/2015	22.5	21.2	0.050	1057	3920	3.870	84.300	77.400	-8.19%
H	5800	HEAD	03/26/2015	22.7	21.1	0.050	1057	3920	3.990	81.100	79.800	-1.60%
D	750	BODY	03/24/2015	23.0	22.1	0.100	1003	3263	0.916	8.460	9.160	8.27%
C	835	BODY	03/19/2015	24.4	22.0	0.100	4d132	3333	0.956	9.140	9.560	4.60%
C	835	BODY	03/23/2015	24.5	21.4	0.100	4d132	3333	0.917	9.140	9.170	0.33%
B	1750	BODY	03/25/2015	23.3	21.4	0.100	1051	3334	3.630	37.400	36.300	-2.94%
J	1900	BODY	03/23/2015	23.3	21.7	0.100	5d141	3022	4.310	40.600	43.100	6.16%
G	2450	BODY	03/17/2015	23.1	22.4	0.100	719	3213	5.290	51.800	52.900	2.12%
G	2450	BODY	03/25/2015	22.9	21.2	0.100	719	3213	5.510	51.800	55.100	6.37%
B	2450	BODY	04/20/2015	23.4	22.5	0.100	882	3334	5.440	50.700	54.400	7.30%
A	5300	BODY	03/31/2015	24.2	20.9	0.050	1191	3914	3.990	79.900	79.800	-0.13%
A	5500	BODY	03/31/2015	24.3	20.8	0.050	1191	3914	4.200	83.100	84.000	1.08%
A	5800	BODY	03/31/2015	24.4	20.6	0.050	1191	3914	3.820	78.000	76.400	-2.05%

FCC ID: ZNFH636	 PCTEST ENGINEERING LABORATORY, INC.	SAR EVALUATION REPORT		Reviewed by: Quality Manager
Document S/N: 0Y1503170617.ZNF	Test Dates: 03/17/15 - 04/20/15	DUT Type: Portable Handset	Page 53 of 77	

**Table 10-4
System Verification Results – 10 g**

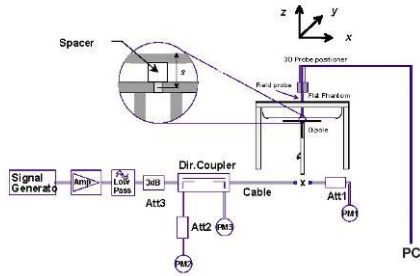

System Verification TARGET & MEASURED												
SAR System #	Tissue Frequency (MHz)	Tissue Type	Date:	Amb. Temp (°C)	Liquid Temp (°C)	Input Power (W)	Dipole SN	Probe SN	Measured SAR _{10g} (W/kg)	1 W Target SAR _{10g} (W/kg)	1 W Normalized SAR _{10g} (W/kg)	Deviation _{10g} (%)
B	2450	BODY	04/20/2015	23.4	22.5	0.100	882	3334	2.480	23.500	24.800	5.53%
A	5300	BODY	03/31/2015	24.2	20.9	0.050	1191	3914	1.100	22.300	22.000	-1.35%
A	5500	BODY	03/31/2015	24.3	20.8	0.050	1191	3914	1.160	23.000	23.200	0.87%



**Figure 10-1
System Verification Setup Diagram**



**Figure 10-2
System Verification Setup Photo**

FCC ID: ZNFH636	 PCTEST <small>ENGINEERING LABORATORY, INC.</small>	SAR EVALUATION REPORT		Reviewed by: Quality Manager
Document S/N: 0Y1503170617.ZNF	Test Dates: 03/17/15 - 04/20/15	DUT Type: Portable Handset	Page 54 of 77	

11 SAR DATA SUMMARY



11.1 Standalone Head SAR Data

**Table 11-1
GSM 850 Head SAR**

MEASUREMENT RESULTS															
FREQUENCY		Mode/Band	Service	Maximum Allowed Power [dBm]	Conducted Power [dBm]	Power Drift [dB]	Side	Test Position	Device Serial Number	# of Time Slots	Duty Cycle	SAR (1g)	Scaling Factor	Scaled SAR (1g)	Plot #
MHz	Ch.											(W/kg)		(W/kg)	
836.60	190	GSM 850	GSM	33.7	33.62	0.02	Right	Cheek	1TU8L	1	1:8.3	0.355	1.019	0.362	A1
836.60	190	GSM 850	GSM	33.7	33.62	0.16	Right	Tilt	1TU8L	1	1:8.3	0.217	1.019	0.221	
836.60	190	GSM 850	GSM	33.7	33.62	-0.07	Left	Cheek	1TU8L	1	1:8.3	0.314	1.019	0.320	
836.60	190	GSM 850	GSM	33.7	33.62	-0.01	Left	Tilt	1TU8L	1	1:8.3	0.216	1.019	0.220	
836.60	190	GSM 850	GPRS	33.7	33.59	0.09	Right	Cheek	1TU8L	1	1:8.3	0.341	1.026	0.350	
836.60	190	GSM 850	GPRS	33.7	33.59	-0.11	Right	Tilt	1TU8L	1	1:8.3	0.188	1.026	0.193	
836.60	190	GSM 850	GPRS	33.7	33.59	0.05	Left	Cheek	1TU8L	1	1:8.3	0.273	1.026	0.280	
836.60	190	GSM 850	GPRS	33.7	33.59	0.16	Left	Tilt	1TU8L	1	1:8.3	0.113	1.026	0.116	
ANSI / IEEE C95.1 1992 - SAFETY LIMIT Spatial Peak Uncontrolled Exposure/General Population							Head 1.6 W/kg (mW/g) averaged over 1 gram								

**Table 11-2
GSM 1900 Head SAR**

MEASUREMENT RESULTS															
FREQUENCY		Mode/Band	Service	Maximum Allowed Power [dBm]	Conducted Power [dBm]	Power Drift [dB]	Side	Test Position	Device Serial Number	# of Time Slots	Duty Cycle	SAR (1g)	Scaling Factor	Scaled SAR (1g)	Plot #
MHz	Ch.											(W/kg)		(W/kg)	
1880.00	661	GSM 1900	GSM	31.2	31.06	0.13	Right	Cheek	1TU8L	1	1:8.3	0.147	1.033	0.152	
1880.00	661	GSM 1900	GSM	31.2	31.06	0.05	Right	Tilt	1TU8L	1	1:8.3	0.120	1.033	0.124	
1880.00	661	GSM 1900	GSM	31.2	31.06	0.14	Left	Cheek	1TU8L	1	1:8.3	0.276	1.033	0.285	
1880.00	661	GSM 1900	GSM	31.2	31.06	-0.16	Left	Tilt	1TU8L	1	1:8.3	0.140	1.033	0.145	
1880.00	661	GSM 1900	GPRS	27.2	26.83	0.02	Right	Cheek	1TU8L	3	1:2.76	0.153	1.089	0.167	
1880.00	661	GSM 1900	GPRS	27.2	26.83	0.02	Right	Tilt	1TU8L	3	1:2.76	0.108	1.089	0.118	
1880.00	661	GSM 1900	GPRS	27.2	26.83	-0.18	Left	Cheek	1TU8L	3	1:2.76	0.293	1.089	0.319	A2
1880.00	661	GSM 1900	GPRS	27.2	26.83	-0.08	Left	Tilt	1TU8L	3	1:2.76	0.148	1.089	0.161	
ANSI / IEEE C95.1 1992 - SAFETY LIMIT Spatial Peak Uncontrolled Exposure/General Population							Head 1.6 W/kg (mW/g) averaged over 1 gram								

FCC ID: ZNFH636	 PCTEST ENGINEERING LABORATORY, INC.	SAR EVALUATION REPORT		Reviewed by: Quality Manager
Document S/N: 0Y1503170617.ZNF	Test Dates: 03/17/15 - 04/20/15	DUT Type: Portable Handset		Page 55 of 77

**Table 11-3
UMTS 850 Head SAR**



MEASUREMENT RESULTS														
FREQUENCY		Mode/Band	Service	Maximum Allowed Power [dBm]	Conducted Power [dBm]	Power Drift [dB]	Side	Test Position	Device Serial Number	Duty Cycle	SAR (1g)	Scaling Factor	Scaled SAR (1g)	Plot #
MHz	Ch.										(W/kg)		(W/kg)	
836.60	4183	UMTS 850	RMC	24.7	24.70	0.01	Right	Cheek	1TU8L	1:1	0.477	1.000	0.477	A3
836.60	4183	UMTS 850	RMC	24.7	24.70	0.05	Right	Tilt	1TU8L	1:1	0.292	1.000	0.292	
836.60	4183	UMTS 850	RMC	24.7	24.70	0.01	Left	Cheek	1TU8L	1:1	0.392	1.000	0.392	
836.60	4183	UMTS 850	RMC	24.7	24.70	0.05	Left	Tilt	1TU8L	1:1	0.282	1.000	0.282	
ANSI / IEEE C95.1 1992 - SAFETY LIMIT Spatial Peak Uncontrolled Exposure/General Population							Head 1.6 W/kg (mW/g) averaged over 1 gram							

**Table 11-4
UMTS 1750 Head SAR**

MEASUREMENT RESULTS														
FREQUENCY		Mode/Band	Service	Maximum Allowed Power [dBm]	Conducted Power [dBm]	Power Drift [dB]	Side	Test Position	Device Serial Number	Duty Cycle	SAR (1g)	Scaling Factor	Scaled SAR (1g)	Plot #
MHz	Ch.										(W/kg)		(W/kg)	
1732.40	1412	UMTS 1750	RMC	23.7	23.68	0.13	Right	Cheek	1TU8L	1:1	0.446	1.005	0.448	
1732.40	1412	UMTS 1750	RMC	23.7	23.68	0.03	Right	Tilt	1TU8L	1:1	0.403	1.005	0.405	
1732.40	1412	UMTS 1750	RMC	23.7	23.68	-0.12	Left	Cheek	1TU8L	1:1	0.626	1.005	0.629	A4
1732.40	1412	UMTS 1750	RMC	23.7	23.68	0.07	Left	Tilt	1TU8L	1:1	0.356	1.005	0.358	
ANSI / IEEE C95.1 1992 - SAFETY LIMIT Spatial Peak Uncontrolled Exposure/General Population							Head 1.6 W/kg (mW/g) averaged over 1 gram							

**Table 11-5
UMTS 1900 Head SAR**

MEASUREMENT RESULTS														
FREQUENCY		Mode/Band	Service	Maximum Allowed Power [dBm]	Conducted Power [dBm]	Power Drift [dB]	Side	Test Position	Device Serial Number	Duty Cycle	SAR (1g)	Scaling Factor	Scaled SAR (1g)	Plot #
MHz	Ch.										(W/kg)		(W/kg)	
1880.00	9400	UMTS 1900	RMC	24.7	24.70	0.06	Right	Cheek	1TU8L	1:1	0.355	1.000	0.355	
1880.00	9400	UMTS 1900	RMC	24.7	24.70	0.00	Right	Tilt	1TU8L	1:1	0.265	1.000	0.265	
1880.00	9400	UMTS 1900	RMC	24.7	24.70	0.00	Left	Cheek	1TU8L	1:1	0.663	1.000	0.663	A5
1880.00	9400	UMTS 1900	RMC	24.7	24.70	0.15	Left	Tilt	1TU8L	1:1	0.315	1.000	0.315	
ANSI / IEEE C95.1 1992 - SAFETY LIMIT Spatial Peak Uncontrolled Exposure/General Population							Head 1.6 W/kg (mW/g) averaged over 1 gram							

FCC ID: ZNFH636	 PCTEST <small>ENGINEERING LABORATORY, INC.</small>	SAR EVALUATION REPORT		Reviewed by: Quality Manager
Document S/N: 0Y1503170617.ZNF	Test Dates: 03/17/15 - 04/20/15	DUT Type: Portable Handset		Page 56 of 77

**Table 11-6
LTE Band 12 Head SAR**



MEASUREMENT RESULTS																			
FREQUENCY		Mode	Bandwidth [MHz]	Maximum Allowed Power [dBm]	Conducted Power [dBm]	Power Drift [dB]	MPR [dB]	Side	Test Position	Modulation	RB Size	RB Offset	Device Serial Number	Duty Cycle	SAR (1g)	Scaling Factor	Scaled SAR (1g)	Plot #	
MHz	Ch.														(W/kg)		(W/kg)		
707.50	23095	Mid	LTE Band 12	10	24.7	24.53	0.06	0	Right	Cheek	QPSK	1	25	1TU8K	1:1	0.365	1.040	0.380	A6
707.50	23095	Mid	LTE Band 12	10	23.7	23.61	0.11	1	Right	Cheek	QPSK	25	12	1TU8K	1:1	0.268	1.021	0.274	
707.50	23095	Mid	LTE Band 12	10	24.7	24.53	-0.14	0	Right	Tilt	QPSK	1	25	1TU8K	1:1	0.203	1.040	0.211	
707.50	23095	Mid	LTE Band 12	10	23.7	23.61	-0.05	1	Right	Tilt	QPSK	25	12	1TU8K	1:1	0.149	1.021	0.152	
707.50	23095	Mid	LTE Band 12	10	24.7	24.53	0.14	0	Left	Cheek	QPSK	1	25	1TU8K	1:1	0.347	1.040	0.361	
707.50	23095	Mid	LTE Band 12	10	23.7	23.61	-0.10	1	Left	Cheek	QPSK	25	12	1TU8K	1:1	0.253	1.021	0.258	
707.50	23095	Mid	LTE Band 12	10	24.7	24.53	0.15	0	Left	Tilt	QPSK	1	25	1TU8K	1:1	0.221	1.040	0.230	
707.50	23095	Mid	LTE Band 12	10	23.7	23.61	0.07	1	Left	Tilt	QPSK	25	12	1TU8K	1:1	0.149	1.021	0.152	
ANSI / IEEE C95.1 1992 - SAFETY LIMIT Spatial Peak Uncontrolled Exposure/General Population										Head 1.6 W/kg (mW/g) averaged over 1 gram									

**Table 11-7
LTE Band 5 (Cell) Head SAR**

MEASUREMENT RESULTS																			
FREQUENCY		Mode	Bandwidth [MHz]	Maximum Allowed Power [dBm]	Conducted Power [dBm]	Power Drift [dB]	MPR [dB]	Side	Test Position	Modulation	RB Size	RB Offset	Device Serial Number	Duty Cycle	SAR (1g)	Scaling Factor	Scaled SAR (1g)	Plot #	
MHz	Ch.														(W/kg)		(W/kg)		
836.50	20525	Mid	LTE Band 5 (Cell)	10	24.2	24.11	0.19	0	Right	Cheek	QPSK	1	25	1TU8K	1:1	0.416	1.021	0.425	A7
836.50	20525	Mid	LTE Band 5 (Cell)	10	23.2	23.11	0.08	1	Right	Cheek	QPSK	25	25	1TU8K	1:1	0.308	1.021	0.314	
836.50	20525	Mid	LTE Band 5 (Cell)	10	24.2	24.11	0.14	0	Right	Tilt	QPSK	1	25	1TU8K	1:1	0.259	1.021	0.264	
836.50	20525	Mid	LTE Band 5 (Cell)	10	23.2	23.11	0.02	1	Right	Tilt	QPSK	25	25	1TU8K	1:1	0.180	1.021	0.184	
836.50	20525	Mid	LTE Band 5 (Cell)	10	24.2	24.11	0.03	0	Left	Cheek	QPSK	1	25	1TU8K	1:1	0.357	1.021	0.364	
836.50	20525	Mid	LTE Band 5 (Cell)	10	23.2	23.11	0.07	1	Left	Cheek	QPSK	25	25	1TU8K	1:1	0.259	1.021	0.264	
836.50	20525	Mid	LTE Band 5 (Cell)	10	24.2	24.11	0.16	0	Left	Tilt	QPSK	1	25	1TU8K	1:1	0.265	1.021	0.271	
836.50	20525	Mid	LTE Band 5 (Cell)	10	23.2	23.11	0.06	1	Left	Tilt	QPSK	25	25	1TU8K	1:1	0.180	1.021	0.184	
ANSI / IEEE C95.1 1992 - SAFETY LIMIT Spatial Peak Uncontrolled Exposure/General Population										Head 1.6 W/kg (mW/g) averaged over 1 gram									

**Table 11-8
LTE Band 4 (AWS) Head SAR**

MEASUREMENT RESULTS																			
FREQUENCY		Mode	Bandwidth [MHz]	Maximum Allowed Power [dBm]	Conducted Power [dBm]	Power Drift [dB]	MPR [dB]	Side	Test Position	Modulation	RB Size	RB Offset	Device Serial Number	Duty Cycle	SAR (1g)	Scaling Factor	Scaled SAR (1g)	Plot #	
MHz	Ch.														(W/kg)		(W/kg)		
1732.50	20175	Mid	LTE Band 4 (AWS)	20	23.7	23.60	0.07	0	Right	Cheek	QPSK	1	0	1TU8K	1:1	0.435	1.023	0.445	
1732.50	20175	Mid	LTE Band 4 (AWS)	20	22.7	22.24	0.03	1	Right	Cheek	QPSK	50	0	1TU8K	1:1	0.318	1.112	0.354	
1732.50	20175	Mid	LTE Band 4 (AWS)	20	23.7	23.60	0.02	0	Right	Tilt	QPSK	1	0	1TU8K	1:1	0.397	1.023	0.406	
1732.50	20175	Mid	LTE Band 4 (AWS)	20	22.7	22.24	-0.06	1	Right	Tilt	QPSK	50	0	1TU8K	1:1	0.310	1.112	0.345	
1732.50	20175	Mid	LTE Band 4 (AWS)	20	23.7	23.60	0.10	0	Left	Cheek	QPSK	1	0	1TU8K	1:1	0.572	1.023	0.585	A8
1732.50	20175	Mid	LTE Band 4 (AWS)	20	22.7	22.24	-0.02	1	Left	Cheek	QPSK	50	0	1TU8K	1:1	0.447	1.112	0.497	
1732.50	20175	Mid	LTE Band 4 (AWS)	20	23.7	23.60	-0.14	0	Left	Tilt	QPSK	1	0	1TU8K	1:1	0.426	1.023	0.436	
1732.50	20175	Mid	LTE Band 4 (AWS)	20	22.7	22.24	0.06	1	Left	Tilt	QPSK	50	0	1TU8K	1:1	0.289	1.112	0.321	
ANSI / IEEE C95.1 1992 - SAFETY LIMIT Spatial Peak Uncontrolled Exposure/General Population										Head 1.6 W/kg (mW/g) averaged over 1 gram									

FCC ID: ZNFH636		SAR EVALUATION REPORT		Reviewed by: Quality Manager
Document S/N: 0Y1503170617.ZNF	Test Dates: 03/17/15 - 04/20/15	DUT Type: Portable Handset		Page 57 of 77

**Table 11-9
LTE Band 2 (PCS) Head SAR**



MEASUREMENT RESULTS																			
FREQUENCY		Mode	Bandwidth [MHz]	Maximum Allowed Power [dBm]	Conducted Power [dBm]	Power Drift [dB]	MPR [dB]	Side	Test Position	Modulation	RB Size	RB Offset	Device Serial Number	Duty Cycle	SAR (1g)	Scaling Factor	Scaled SAR (1g)	Plot #	
MHz	Ch.														(W/kg)		(W/kg)		
1880.00	18900	Mid	LTE Band 2 (PCS)	20	23.7	23.54	0.03	0	Right	Cheek	QPSK	1	99	1TU8K	1:1	0.246	1.038	0.255	
1860.00	18700	Low	LTE Band 2 (PCS)	20	22.7	22.28	-0.06	1	Right	Cheek	QPSK	50	0	1TU8K	1:1	0.173	1.102	0.191	
1880.00	18900	Mid	LTE Band 2 (PCS)	20	23.7	23.54	0.12	0	Right	Tilt	QPSK	1	99	1TU8K	1:1	0.225	1.038	0.234	
1860.00	18700	Low	LTE Band 2 (PCS)	20	22.7	22.28	0.13	1	Right	Tilt	QPSK	50	0	1TU8K	1:1	0.164	1.102	0.181	
1880.00	18900	Mid	LTE Band 2 (PCS)	20	23.7	23.54	0.12	0	Left	Cheek	QPSK	1	99	1TU8K	1:1	0.519	1.038	0.539	A9
1860.00	18700	Low	LTE Band 2 (PCS)	20	22.7	22.28	0.15	1	Left	Cheek	QPSK	50	0	1TU8K	1:1	0.350	1.102	0.386	
1880.00	18900	Mid	LTE Band 2 (PCS)	20	23.7	23.54	0.14	0	Left	Tilt	QPSK	1	99	1TU8K	1:1	0.298	1.038	0.309	
1860.00	18700	Low	LTE Band 2 (PCS)	20	22.7	22.28	0.05	1	Left	Tilt	QPSK	50	0	1TU8K	1:1	0.212	1.102	0.234	
ANSI / IEEE C95.1 1992 - SAFETY LIMIT Spatial Peak Uncontrolled Exposure/General Population										Head 1.6 W/kg (mW/g) averaged over 1 gram									

**Table 11-10
LTE Band 7 Head SAR**

MEASUREMENT RESULTS																			
FREQUENCY		Mode	Bandwidth [MHz]	Maximum Allowed Power [dBm]	Conducted Power [dBm]	Power Drift [dB]	MPR [dB]	Side	Test Position	Modulation	RB Size	RB Offset	Device Serial Number	Duty Cycle	SAR (1g)	Scaling Factor	Scaled SAR (1g)	Plot #	
MHz	Ch.														(W/kg)		(W/kg)		
2510.00	20850	Low	LTE Band 7	20	23.7	23.35	0.13	0	Right	Cheek	QPSK	1	50	1TU8K	1:1	0.109	1.084	0.118	A10
2510.00	20850	Low	LTE Band 7	20	22.7	21.89	0.18	1	Right	Cheek	QPSK	50	0	1TU8K	1:1	0.078	1.205	0.094	
2510.00	20850	Low	LTE Band 7	20	23.7	23.35	0.12	0	Right	Tilt	QPSK	1	50	1TU8K	1:1	0.052	1.084	0.056	
2510.00	20850	Low	LTE Band 7	20	22.7	21.89	0.14	1	Right	Tilt	QPSK	50	0	1TU8K	1:1	0.037	1.205	0.045	
2510.00	20850	Low	LTE Band 7	20	23.7	23.35	-0.19	0	Left	Cheek	QPSK	1	50	1TU8K	1:1	0.079	1.084	0.086	
2510.00	20850	Low	LTE Band 7	20	22.7	21.89	-0.03	1	Left	Cheek	QPSK	50	0	1TU8K	1:1	0.062	1.205	0.075	
2510.00	20850	Low	LTE Band 7	20	23.7	23.35	0.17	0	Left	Tilt	QPSK	1	50	1TU8K	1:1	0.069	1.084	0.075	
2510.00	20850	Low	LTE Band 7	20	22.7	21.89	0.03	1	Left	Tilt	QPSK	50	0	1TU8K	1:1	0.054	1.205	0.065	
ANSI / IEEE C95.1 1992 - SAFETY LIMIT Spatial Peak Uncontrolled Exposure/General Population										Head 1.6 W/kg (mW/g) averaged over 1 gram									

**Table 11-11
DTS Head SAR**

MEASUREMENT RESULTS																		
FREQUENCY		Mode	Service	Bandwidth [MHz]	Maximum Allowed Power [dBm]	Conducted Power [dBm]	Power Drift [dB]	Side	Test Position	Device Serial Number	Data Rate (Mbps)	Duty Cycle (%)	Peak SAR of Area Scan	SAR (1g)	Scaling Factor (Power)	Scaling Factor (Duty Cycle)	Scaled SAR (1g)	Plot #
MHz	Ch.												(W/kg)	(W/kg)			(W/kg)	
2437	6	802.11b	DSSS	22	16.0	15.98	-	Right	Cheek	1TU8Q	1	99.3	0.101	-	1.005	1.007	-	
2437	6	802.11b	DSSS	22	16.0	15.98	-	Right	Tilt	1TU8Q	1	99.3	0.081	-	1.005	1.007	-	
2437	6	802.11b	DSSS	22	16.0	15.98	0.04	Left	Cheek	1TU8Q	1	99.3	0.307	0.240	1.005	1.007	0.243	A11
2437	6	802.11b	DSSS	22	16.0	15.98	-	Left	Tilt	1TU8Q	1	99.3	0.254	-	1.005	1.007	-	
ANSI / IEEE C95.1 1992 - SAFETY LIMIT Spatial Peak Uncontrolled Exposure/General Population										Head 1.6 W/kg (mW/g) averaged over 1 gram								

FCC ID: ZNFH636		SAR EVALUATION REPORT		Reviewed by: Quality Manager
Document S/N: 0Y1503170617.ZNF	Test Dates: 03/17/15 - 04/20/15	DUT Type: Portable Handset		Page 58 of 77



**Table 11-12
NII Head SAR**

MEASUREMENT RESULTS																		
FREQUENCY		Mode	Service	Bandwidth [MHz]	Maximum Allowed Power [dBm]	Conducted Power [dBm]	Power Drift [dB]	Side	Test Position	Device Serial Number	Data Rate (Mbps)	Duty Cycle (%)	Peak SAR of Area Scan [W/kg]	SAR (1g) [W/kg]	Scaling Factor (Power)	Scaling Factor (Duty Cycle)	Scaled SAR (1g) [W/kg]	Plot #
MHz	Ch.																	
5270	54	802.11n	OFDM	40	15.0	14.01	-	Right	Cheek	1TU8Q	13.5	93.0	0.215	-	1.256	1.075	-	-
5270	54	802.11n	OFDM	40	15.0	14.01	-	Right	Tilt	1TU8Q	13.5	93.0	0.176	-	1.256	1.075	-	-
5270	54	802.11n	OFDM	40	15.0	14.01	0.10	Left	Cheek	1TU8Q	13.5	93.0	0.532	0.217	1.256	1.075	0.293	-
5270	54	802.11n	OFDM	40	15.0	14.01	-	Left	Tilt	1TU8Q	13.5	93.0	0.267	-	1.256	1.075	-	-
5510	102	802.11n	OFDM	40	15.0	13.95	-	Right	Cheek	1TU8Q	13.5	93.0	0.229	-	1.274	1.075	-	-
5510	102	802.11n	OFDM	40	15.0	13.95	-	Right	Tilt	1TU8Q	13.5	93.0	0.170	-	1.274	1.075	-	-
5510	102	802.11n	OFDM	40	15.0	13.95	0.14	Left	Cheek	1TU8Q	13.5	93.0	0.537	0.219	1.274	1.075	0.300	-
5510	102	802.11n	OFDM	40	15.0	13.95	-	Left	Tilt	1TU8Q	13.5	93.0	0.273	-	1.274	1.075	-	-
5795	159	802.11n	OFDM	40	15.0	13.92	-	Right	Cheek	1TU8Q	13.5	93.0	0.306	-	1.282	1.075	-	-
5795	159	802.11n	OFDM	40	15.0	13.92	-	Right	Tilt	1TU8Q	13.5	93.0	0.249	-	1.282	1.075	-	-
5795	159	802.11n	OFDM	40	15.0	13.92	0.10	Left	Cheek	1TU8Q	13.5	93.0	0.682	0.260	1.282	1.075	0.358	A12
5795	159	802.11n	OFDM	40	15.0	13.92	-	Left	Tilt	1TU8Q	13.5	93.0	0.371	-	1.282	1.075	-	-
ANSI / IEEE C95.1 1992 - SAFETY LIMIT Spatial Peak Uncontrolled Exposure/General Population									Head 1.6 W/kg (mW/g) averaged over 1 gram									

11.2 Standalone Body-Worn SAR Data

**Table 11-13
GSM/UMTS Body-Worn SAR Data**

MEASUREMENT RESULTS															
FREQUENCY		Mode	Service	Maximum Allowed Power [dBm]	Conducted Power [dBm]	Power Drift [dB]	Spacing	Device Serial Number	# of Time Slots	Duty Cycle	Side	SAR (1g) [W/kg]	Scaling Factor	Scaled SAR (1g) [W/kg]	Plot #
MHz	Ch.														
836.60	190	GSM 850	GSM	33.7	33.62	0.04	10 mm	1TU8L	1	1:8.3	back	0.413	1.019	0.421	A13
836.60	190	GSM 850	GPRS	33.7	33.59	0.01	10 mm	1TU8L	1	1:8.3	back	0.393	1.026	0.403	-
1880.00	661	GSM 1900	GSM	31.2	31.06	-0.07	10 mm	1TU8L	1	1:8.3	back	0.371	1.033	0.383	-
1880.00	661	GSM 1900	GPRS	27.2	26.83	-0.03	10 mm	1TU8L	3	1:2.76	back	0.382	1.089	0.416	A15
836.60	4183	UMTS 850	RMC	24.7	24.70	0.05	10 mm	1TU8L	N/A	1:1	back	0.645	1.000	0.645	A16
1732.40	1412	UMTS 1750	RMC	23.7	23.68	0.06	10 mm	1TU8L	N/A	1:1	back	0.720	1.005	0.724	A18
1880.00	9400	UMTS 1900	RMC	24.7	24.70	0.00	10 mm	1TU8L	N/A	1:1	back	0.783	1.000	0.783	A20
ANSI / IEEE C95.1 1992 - SAFETY LIMIT Spatial Peak Uncontrolled Exposure/General Population									Body 1.6 W/kg (mW/g) averaged over 1 gram						

FCC ID: ZNFH636		SAR EVALUATION REPORT		Reviewed by: Quality Manager
Document S/N: 0Y1503170617.ZNF	Test Dates: 03/17/15 - 04/20/15	DUT Type: Portable Handset		Page 59 of 77

**Table 11-14
LTE Body-Worn SAR**

MEASUREMENT RESULTS																			
FREQUENCY		Mode	Service	Bandwidth [MHz]	Maximum Allowed Power [dBm]	Conducted Power [dBm]	Power Drift [dB]	MPR [dB]	Device Serial Number	Modulation	RB Size	RB Offset	Spacing	Side	Duty Cycle	SAR (1g) (W/kg)	Scaling Factor	Scaled SAR (1g) (W/kg)	Plot #
MHz	Ch.																		
707.50	23095	Mid	LTE Band 12	10	24.7	24.53	0.15	0	1TU8K	QPSK	1	25	10 mm	back	1:1	0.734	1.040	0.763	A21
707.50	23095	Mid	LTE Band 12	10	23.7	23.61	0.02	1	1TU8K	QPSK	25	12	10 mm	back	1:1	0.543	1.021	0.554	
836.50	20525	Mid	LTE Band 5 (Cell)	10	24.2	24.11	0.17	0	1TU8K	QPSK	1	25	10 mm	back	1:1	0.568	1.021	0.580	A22
836.50	20525	Mid	LTE Band 5 (Cell)	10	23.2	23.11	0.14	1	1TU8K	QPSK	25	25	10 mm	back	1:1	0.413	1.021	0.422	
1732.50	20175	Mid	LTE Band 4 (AWS)	20	23.7	23.60	-0.14	0	1TU8K	QPSK	1	0	10 mm	back	1:1	0.808	1.023	0.827	
1732.50	20175	Mid	LTE Band 4 (AWS)	20	22.7	22.24	0.01	1	1TU8K	QPSK	50	0	10 mm	back	1:1	0.574	1.112	0.638	
1732.50	20175	Mid	LTE Band 4 (AWS)	20	22.7	22.01	0.03	1	1TU8K	QPSK	100	0	10 mm	back	1:1	0.525	1.172	0.615	
1732.50	20175	Mid	LTE Band 4 (AWS)	20	23.7	23.60	0.18	0	1TU8K	QPSK	1	0	10 mm	back	1:1	0.838	1.023	0.857	A24
1880.00	18900	Mid	LTE Band 2 (PCS)	20	23.7	23.54	-0.04	0	1TU8K	QPSK	1	99	10 mm	back	1:1	0.714	1.038	0.741	A25
1860.00	18700	Low	LTE Band 2 (PCS)	20	22.7	22.28	-0.05	1	1TU8K	QPSK	50	0	10 mm	back	1:1	0.449	1.102	0.495	
2510.00	20850	Low	LTE Band 7	20	23.7	23.35	-0.15	0	1TU8K	QPSK	1	50	10 mm	back	1:1	0.386	1.084	0.418	A26
2510.00	20850	Low	LTE Band 7	20	22.7	21.89	0.09	1	1TU8K	QPSK	50	0	10 mm	back	1:1	0.281	1.205	0.339	
ANSI / IEEE C95.1 1992 - SAFETY LIMIT Spatial Peak Uncontrolled Exposure/General Population										Body 1.6 W/kg (mW/g) averaged over 1 gram									

Blue entry represents variability measurement.

**Table 11-15
DTS Body-Worn SAR**



MEASUREMENT RESULTS																		
FREQUENCY		Mode	Service	Bandwidth [MHz]	Maximum Allowed Power [dBm]	Conducted Power [dBm]	Power Drift [dB]	Spacing	Device Serial Number	Data Rate (Mbps)	Side	Duty Cycle (%)	Peak SAR of Area Scan (W/kg)	SAR (1g) (W/kg)	Scaling Factor (Power)	Scaling Factor (Duty Cycle)	Scaled SAR (1g) (W/kg)	Plot #
MHz	Ch.																	
2437	6	802.11b	DSSS	22	16.0	15.98	-0.09	10 mm	1TU8Q	1	back	99.3	0.127	0.094	1.005	1.007	0.095	A27
ANSI / IEEE C95.1 1992 - SAFETY LIMIT Spatial Peak Uncontrolled Exposure/General Population										Body 1.6 W/kg (mW/g) averaged over 1 gram								

**Table 11-16
NII Body-Worn SAR**

MEASUREMENT RESULTS																		
FREQUENCY		Mode	Service	Bandwidth [MHz]	Maximum Allowed Power [dBm]	Conducted Power [dBm]	Power Drift [dB]	Spacing	Device Serial Number	Data Rate (Mbps)	Side	Duty Cycle (%)	Peak SAR of Area Scan (W/kg)	SAR (1g) (W/kg)	Scaling Factor (Power)	Scaling Factor (Duty Cycle)	Scaled SAR (1g) (W/kg)	Plot #
MHz	Ch.																	
5270	54	802.11n	OFDM	40	15.0	14.01	0.17	10 mm	1TU8Q	13.5	back	93.0	0.144	0.056	1.256	1.075	0.075	
5510	102	802.11n	OFDM	40	15.0	13.95	0.20	10 mm	1TU8Q	13.5	back	93.0	0.218	0.080	1.274	1.075	0.110	
5795	159	802.11n	OFDM	40	15.0	13.92	-0.09	10 mm	1TU8Q	13.5	back	93.0	0.246	0.090	1.282	1.075	0.124	A28
ANSI / IEEE C95.1 1992 - SAFETY LIMIT Spatial Peak Uncontrolled Exposure/General Population										Body 1.6 W/kg (mW/g) averaged over 1 gram								

**Table 11-17
DSS Body-Worn SAR**

MEASUREMENT RESULTS																	
FREQUENCY		Mode	Service	Maximum Allowed Power [dBm]	Conducted Power [dBm]	Power Drift [dB]	Spacing	Device Serial Number	Data Rate (Mbps)	Side	Duty Cycle	SAR (1g) (W/kg)	Scaling Factor	Scaled SAR (1g) (W/kg)	Plot #		
MHz	Ch.																
2441	39	Bluetooth	FHSS	10.0	9.40	0.16	10 mm	1MKUW	1	back	1:1	0.010	1.148	0.011	A29		
ANSI / IEEE C95.1 1992 - SAFETY LIMIT Spatial Peak Uncontrolled Exposure/General Population										Body 1.6 W/kg (mW/g) averaged over 1 gram							

FCC ID: ZNFH636		SAR EVALUATION REPORT		Reviewed by: Quality Manager
Document S/N: 0Y1503170617.ZNF	Test Dates: 03/17/15 - 04/20/15	DUT Type: Portable Handset		Page 60 of 77



11.3 Standalone Wireless Router SAR Data

**Table 11-18
GPRS/UMTS Hotspot SAR Data**

MEASUREMENT RESULTS															
FREQUENCY		Mode	Service	Maximum Allowed Power [dBm]	Conducted Power [dBm]	Power Drift [dB]	Spacing	Device Serial Number	# of GPRS Slots	Duty Cycle	Side	SAR (1g)	Scaling Factor	Scaled SAR (1g)	Plot #
MHz	Ch.											(W/kg)		(W/kg)	
836.60	190	GSM 850	GPRS	33.7	33.59	0.01	10 mm	1TU8L	1	1:8.3	back	0.393	1.026	0.403	
836.60	190	GSM 850	GPRS	33.7	33.59	0.09	10 mm	1TU8L	1	1:8.3	front	0.326	1.026	0.334	
836.60	190	GSM 850	GPRS	33.7	33.59	0.04	10 mm	1TU8L	1	1:8.3	bottom	0.337	1.026	0.346	
836.60	190	GSM 850	GPRS	33.7	33.59	-0.01	10 mm	1TU8L	1	1:8.3	right	0.532	1.026	0.546	A14
1880.00	661	GSM 1900	GPRS	27.2	26.83	-0.03	10 mm	1TU8L	3	1:2.76	back	0.382	1.089	0.416	A15
1880.00	661	GSM 1900	GPRS	27.2	26.83	-0.05	10 mm	1TU8L	3	1:2.76	front	0.343	1.089	0.374	
1880.00	661	GSM 1900	GPRS	27.2	26.83	-0.03	10 mm	1TU8L	3	1:2.76	bottom	0.243	1.089	0.265	
1880.00	661	GSM 1900	GPRS	27.2	26.83	0.03	10 mm	1TU8L	3	1:2.76	left	0.256	1.089	0.279	
836.60	4183	UMTS 850	RMC	24.7	24.70	0.05	10 mm	1TU8L	N/A	1:1	back	0.645	1.000	0.645	
836.60	4183	UMTS 850	RMC	24.7	24.70	-0.01	10 mm	1TU8L	N/A	1:1	front	0.514	1.000	0.514	
836.60	4183	UMTS 850	RMC	24.7	24.70	-0.02	10 mm	1TU8L	N/A	1:1	bottom	0.530	1.000	0.530	
836.60	4183	UMTS 850	RMC	24.7	24.70	0.01	10 mm	1TU8L	N/A	1:1	right	0.764	1.000	0.764	A17
1732.40	1412	UMTS 1750	RMC	23.7	23.68	0.06	10 mm	1TU8L	N/A	1:1	back	0.720	1.005	0.724	
1732.40	1412	UMTS 1750	RMC	23.7	23.68	0.04	10 mm	1TU8L	N/A	1:1	front	0.792	1.005	0.796	A19
1732.40	1412	UMTS 1750	RMC	23.7	23.68	0.08	10 mm	1TU8L	N/A	1:1	bottom	0.553	1.005	0.556	
1732.40	1412	UMTS 1750	RMC	23.7	23.68	0.09	10 mm	1TU8L	N/A	1:1	left	0.575	1.005	0.578	
1880.00	9400	UMTS 1900	RMC	24.7	24.70	0.00	10 mm	1TU8L	N/A	1:1	back	0.783	1.000	0.783	A20
1880.00	9400	UMTS 1900	RMC	24.7	24.70	-0.05	10 mm	1TU8L	N/A	1:1	front	0.763	1.000	0.763	
1880.00	9400	UMTS 1900	RMC	24.7	24.70	-0.03	10 mm	1TU8L	N/A	1:1	bottom	0.577	1.000	0.577	
1880.00	9400	UMTS 1900	RMC	24.7	24.70	0.01	10 mm	1TU8L	N/A	1:1	left	0.550	1.000	0.550	
ANSI / IEEE C95.1 1992 - SAFETY LIMIT Spatial Peak Uncontrolled Exposure/General Population								Body 1.6 W/kg (mW/g) averaged over 1 gram							

**Table 11-19
LTE Band 12 Hotspot SAR**

MEASUREMENT RESULTS																			
FREQUENCY		Mode	Bandwidth [MHz]	Maximum Allowed Power [dBm]	Conducted Power [dBm]	Power Drift [dB]	MPR [dB]	Device Serial Number	Modulation	RB Size	RB Offset	Spacing	Side	Duty Cycle	SAR (1g)	Scaling Factor	Scaled SAR (1g)	Plot #	
MHz	Ch.														(W/kg)		(W/kg)		
707.50	23095	Mid	LTE Band 12	10	24.7	24.53	0.15	0	1TU8K	QPSK	1	25	10 mm	back	1:1	0.734	1.040	0.763	A21
707.50	23095	Mid	LTE Band 12	10	23.7	23.61	0.02	1	1TU8K	QPSK	25	12	10 mm	back	1:1	0.543	1.021	0.554	
707.50	23095	Mid	LTE Band 12	10	24.7	24.53	-0.12	0	1TU8K	QPSK	1	25	10 mm	front	1:1	0.519	1.040	0.540	
707.50	23095	Mid	LTE Band 12	10	23.7	23.61	-0.06	1	1TU8K	QPSK	25	12	10 mm	front	1:1	0.384	1.021	0.392	
707.50	23095	Mid	LTE Band 12	10	24.7	24.53	0.14	0	1TU8K	QPSK	1	25	10 mm	bottom	1:1	0.237	1.040	0.246	
707.50	23095	Mid	LTE Band 12	10	23.7	23.61	-0.03	1	1TU8K	QPSK	25	12	10 mm	bottom	1:1	0.181	1.021	0.185	
707.50	23095	Mid	LTE Band 12	10	24.7	24.53	0.15	0	1TU8K	QPSK	1	25	10 mm	right	1:1	0.213	1.040	0.222	
707.50	23095	Mid	LTE Band 12	10	23.7	23.61	0.06	1	1TU8K	QPSK	25	12	10 mm	right	1:1	0.163	1.021	0.166	
ANSI / IEEE C95.1 1992 - SAFETY LIMIT Spatial Peak Uncontrolled Exposure/General Population								Body 1.6 W/kg (mW/g) averaged over 1 gram											

FCC ID: ZNFH636	 PCTEST ENGINEERING LABORATORY, INC.	SAR EVALUATION REPORT		Reviewed by: Quality Manager
Document S/N: 0Y1503170617.ZNF	Test Dates: 03/17/15 - 04/20/15	DUT Type: Portable Handset	Page 61 of 77	

**Table 11-20
LTE Band 5 (Cell) Hotspot SAR**

MEASUREMENT RESULTS																			
FREQUENCY		Mode	Bandwidth [MHz]	Maximum Allowed Power [dBm]	Conducted Power [dBm]	Power Drift [dB]	MPR [dB]	Device Serial Number	Modulation	RB Size	RB Offset	Spacing	Side	Duty Cycle	SAR (1g)	Scaling Factor	Scaled SAR (1g)	Plot #	
MHz	Ch.														(W/kg)		(W/kg)		
836.50	20525	Mid	LTE Band 5 (Cell)	10	24.2	24.11	0.17	0	1TU8K	QPSK	1	25	10 mm	back	1:1	0.568	1.021	0.580	
836.50	20525	Mid	LTE Band 5 (Cell)	10	23.2	23.11	0.14	1	1TU8K	QPSK	25	25	10 mm	back	1:1	0.413	1.021	0.422	
836.50	20525	Mid	LTE Band 5 (Cell)	10	24.2	24.11	-0.01	0	1TU8K	QPSK	1	25	10 mm	front	1:1	0.452	1.021	0.461	
836.50	20525	Mid	LTE Band 5 (Cell)	10	23.2	23.11	0.03	1	1TU8K	QPSK	25	25	10 mm	front	1:1	0.331	1.021	0.338	
836.50	20525	Mid	LTE Band 5 (Cell)	10	24.2	24.11	0.12	0	1TU8K	QPSK	1	25	10 mm	bottom	1:1	0.451	1.021	0.460	
836.50	20525	Mid	LTE Band 5 (Cell)	10	23.2	23.11	-0.01	1	1TU8K	QPSK	25	25	10 mm	bottom	1:1	0.356	1.021	0.363	
836.50	20525	Mid	LTE Band 5 (Cell)	10	24.2	24.11	0.13	0	1TU8K	QPSK	1	25	10 mm	right	1:1	0.694	1.021	0.709	A23
836.50	20525	Mid	LTE Band 5 (Cell)	10	23.2	23.11	0.00	1	1TU8K	QPSK	25	25	10 mm	right	1:1	0.529	1.021	0.540	
ANSI / IEEE C95.1 1992 - SAFETY LIMIT Spatial Peak Uncontrolled Exposure/General Population										Body 1.6 W/kg (mW/g) averaged over 1 gram									



**Table 11-21
LTE Band 4 (AWS) Hotspot SAR**

MEASUREMENT RESULTS																			
FREQUENCY		Mode	Bandwidth [MHz]	Maximum Allowed Power [dBm]	Conducted Power [dBm]	Power Drift [dB]	MPR [dB]	Device Serial Number	Modulation	RB Size	RB Offset	Spacing	Side	Duty Cycle	SAR (1g)	Scaling Factor	Scaled SAR (1g)	Plot #	
MHz	Ch.														(W/kg)		(W/kg)		
1732.50	20175	Mid	LTE Band 4 (AWS)	20	23.7	23.60	-0.14	0	1TU8K	QPSK	1	0	10 mm	back	1:1	0.808	1.023	0.827	
1732.50	20175	Mid	LTE Band 4 (AWS)	20	22.7	22.24	0.01	1	1TU8K	QPSK	50	0	10 mm	back	1:1	0.574	1.112	0.638	
1732.50	20175	Mid	LTE Band 4 (AWS)	20	22.7	22.01	0.03	1	1TU8K	QPSK	100	0	10 mm	back	1:1	0.525	1.172	0.615	
1732.50	20175	Mid	LTE Band 4 (AWS)	20	23.7	23.60	0.10	0	1TU8K	QPSK	1	0	10 mm	front	1:1	0.769	1.023	0.787	
1732.50	20175	Mid	LTE Band 4 (AWS)	20	22.7	22.24	-0.03	1	1TU8K	QPSK	50	0	10 mm	front	1:1	0.540	1.112	0.600	
1732.50	20175	Mid	LTE Band 4 (AWS)	20	23.7	23.60	0.14	0	1TU8K	QPSK	1	0	10 mm	bottom	1:1	0.569	1.023	0.582	
1732.50	20175	Mid	LTE Band 4 (AWS)	20	22.7	22.24	0.04	1	1TU8K	QPSK	50	0	10 mm	bottom	1:1	0.413	1.112	0.459	
1732.50	20175	Mid	LTE Band 4 (AWS)	20	23.7	23.60	-0.20	0	1TU8K	QPSK	1	0	10 mm	left	1:1	0.563	1.023	0.576	
1732.50	20175	Mid	LTE Band 4 (AWS)	20	22.7	22.24	-0.04	1	1TU8K	QPSK	50	0	10 mm	left	1:1	0.413	1.112	0.459	
1732.50	20175	Mid	LTE Band 4 (AWS)	20	23.7	23.60	0.18	0	1TU8K	QPSK	1	0	10 mm	back	1:1	0.838	1.023	0.857	A24
ANSI / IEEE C95.1 1992 - SAFETY LIMIT Spatial Peak Uncontrolled Exposure/General Population										Body 1.6 W/kg (mW/g) averaged over 1 gram									

Blue entry represents variability measurement.

**Table 11-22
LTE Band 2 (PCS) Hotspot SAR**

MEASUREMENT RESULTS																			
FREQUENCY		Mode	Bandwidth [MHz]	Maximum Allowed Power [dBm]	Conducted Power [dBm]	Power Drift [dB]	MPR [dB]	Device Serial Number	Modulation	RB Size	RB Offset	Spacing	Side	Duty Cycle	SAR (1g)	Scaling Factor	Scaled SAR (1g)	Plot #	
MHz	Ch.														(W/kg)		(W/kg)		
1880.00	18900	Mid	LTE Band 2 (PCS)	20	23.7	23.54	-0.04	0	1TU8K	QPSK	1	99	10 mm	back	1:1	0.714	1.038	0.741	A25
1860.00	18700	Low	LTE Band 2 (PCS)	20	22.7	22.28	-0.05	1	1TU8K	QPSK	50	0	10 mm	back	1:1	0.449	1.102	0.495	
1880.00	18900	Mid	LTE Band 2 (PCS)	20	23.7	23.54	-0.16	0	1TU8K	QPSK	1	99	10 mm	front	1:1	0.645	1.038	0.670	
1860.00	18700	Low	LTE Band 2 (PCS)	20	22.7	22.28	0.06	1	1TU8K	QPSK	50	0	10 mm	front	1:1	0.397	1.102	0.437	
1880.00	18900	Mid	LTE Band 2 (PCS)	20	23.7	23.54	0.12	0	1TU8K	QPSK	1	99	10 mm	bottom	1:1	0.415	1.038	0.431	
1860.00	18700	Low	LTE Band 2 (PCS)	20	22.7	22.28	0.03	1	1TU8K	QPSK	50	0	10 mm	bottom	1:1	0.259	1.102	0.285	
1880.00	18900	Mid	LTE Band 2 (PCS)	20	23.7	23.54	0.15	0	1TU8K	QPSK	1	99	10 mm	left	1:1	0.475	1.038	0.493	
1860.00	18700	Low	LTE Band 2 (PCS)	20	22.7	22.28	-0.02	1	1TU8K	QPSK	50	0	10 mm	left	1:1	0.285	1.102	0.314	
ANSI / IEEE C95.1 1992 - SAFETY LIMIT Spatial Peak Uncontrolled Exposure/General Population										Body 1.6 W/kg (mW/g) averaged over 1 gram									

FCC ID: ZNFH636		SAR EVALUATION REPORT		Reviewed by: Quality Manager
Document S/N: 0Y1503170617.ZNF	Test Dates: 03/17/15 - 04/20/15	DUT Type: Portable Handset	Page 62 of 77	

**Table 11-23
LTE Band 7 Hotspot SAR**

MEASUREMENT RESULTS																			
FREQUENCY		Mode	Bandwidth [MHz]	Maximum Allowed Power [dBm]	Conducted Power [dBm]	Power Drift [dB]	MPR [dB]	Device Serial Number	Modulation	RB Size	RB Offset	Spacing	Side	Duty Cycle	SAR (1g) (W/kg)	Scaling Factor	Scaled SAR (1g) (W/kg)	Plot #	
MHz	Ch.																		
2510.00	20850	Low	LTE Band 7	20	23.7	23.35	-0.15	0	1TU8K	QPSK	1	50	10 mm	back	1:1	0.386	1.084	0.418	A26
2510.00	20850	Low	LTE Band 7	20	22.7	21.89	0.09	1	1TU8K	QPSK	50	0	10 mm	back	1:1	0.281	1.205	0.339	
2510.00	20850	Low	LTE Band 7	20	23.7	23.35	0.00	0	1TU8K	QPSK	1	50	10 mm	front	1:1	0.282	1.084	0.306	
2510.00	20850	Low	LTE Band 7	20	22.7	21.89	0.08	1	1TU8K	QPSK	50	0	10 mm	front	1:1	0.203	1.205	0.245	
2510.00	20850	Low	LTE Band 7	20	23.7	23.35	0.16	0	1TU8K	QPSK	1	50	10 mm	bottom	1:1	0.358	1.084	0.388	
2510.00	20850	Low	LTE Band 7	20	22.7	21.89	-0.03	1	1TU8K	QPSK	50	0	10 mm	bottom	1:1	0.273	1.205	0.329	
2510.00	20850	Low	LTE Band 7	20	23.7	23.35	0.12	0	1TU8K	QPSK	1	50	10 mm	right	1:1	0.096	1.084	0.104	
2510.00	20850	Low	LTE Band 7	20	22.7	21.89	0.04	1	1TU8K	QPSK	50	0	10 mm	right	1:1	0.066	1.205	0.080	
ANSI / IEEE C95.1 1992 - SAFETY LIMIT Spatial Peak Uncontrolled Exposure/General Population								Body 1.6 W/kg (mW/g) averaged over 1 gram											



**Table 11-24
WLAN Hotspot SAR**

MEASUREMENT RESULTS																		
FREQUENCY		Mode	Service	Bandwidth [MHz]	Maximum Allowed Power [dBm]	Conducted Power [dBm]	Power Drift [dB]	Spacing	Device Serial Number	Data Rate (Mbps)	Side	Duty Cycle (%)	Peak SAR of Area Scan (W/kg)	SAR (1g) (W/kg)	Scaling Factor (Power)	Scaling Factor (Duty Cycle)	Scaled SAR (1g) (W/kg)	Plot #
MHz	Ch.																	
2437	6	802.11b	DSSS	22	16.0	15.98	-0.09	10 mm	1TU8Q	1	back	99.3	0.127	0.094	1.005	1.007	0.095	A27
2437	6	802.11b	DSSS	22	16.0	15.98	-	10 mm	1TU8Q	1	front	99.3	0.048	-	1.005	1.007	-	
2437	6	802.11b	DSSS	22	16.0	15.98	-	10 mm	1TU8Q	1	top	99.3	0.042	-	1.005	1.007	-	
2437	6	802.11b	DSSS	22	16.0	15.98	-	10 mm	1TU8Q	1	right	99.3	0.031	-	1.005	1.007	-	
5795	159	802.11n	OFDM	40	15.0	13.92	-0.09	10 mm	1TU8Q	13.5	back	93.0	0.246	0.090	1.282	1.075	0.124	A28
5795	159	802.11n	OFDM	40	15.0	13.92	-	10 mm	1TU8Q	13.5	front	93.0	0.114	-	1.282	1.075	-	
5795	159	802.11n	OFDM	40	15.0	13.92	-	10 mm	1TU8Q	13.5	top	93.0	0.092	-	1.282	1.075	-	
5795	159	802.11n	OFDM	40	15.0	13.92	-	10 mm	1TU8Q	13.5	right	93.0	0.181	-	1.282	1.075	-	
ANSI / IEEE C95.1 1992 - SAFETY LIMIT Spatial Peak Uncontrolled Exposure/General Population								Body 1.6 W/kg (mW/g) averaged over 1 gram										

11.4 Standalone Hand SAR Data

**Table 11-25
WLAN Extremity SAR**

MEASUREMENT RESULTS																		
FREQUENCY		Mode	Service	Bandwidth [MHz]	Maximum Allowed Power [dBm]	Conducted Power [dBm]	Power Drift [dB]	Spacing	Device Serial Number	Data Rate (Mbps)	Side	Duty Cycle (%)	Peak SAR of Area Scan (W/kg)	SAR (10g) (W/kg)	Scaling Factor (Power)	Scaling Factor (Duty Cycle)	Scaled SAR (10g) (W/kg)	Plot #
MHz	Ch.																	
5270	54	802.11n	OFDM	40	15.0	14.01	0.12	0 mm	1TU8Q	13.5	back	93.0	2.440	0.175	1.256	1.075	0.237	
5270	54	802.11n	OFDM	40	15.0	14.01	-	0 mm	1TU8Q	13.5	front	93.0	1.120	-	1.256	1.075	-	
5270	54	802.11n	OFDM	40	15.0	14.01	-	0 mm	1TU8Q	13.5	top	93.0	0.543	-	1.256	1.075	-	
5270	54	802.11n	OFDM	40	15.0	14.01	-	0 mm	1TU8Q	13.5	right	93.0	1.790	-	1.256	1.075	-	
5510	102	802.11n	OFDM	40	15.0	13.95	0.14	0 mm	1TU8Q	13.5	back	93.0	3.730	0.208	1.274	1.075	0.285	A30
5510	102	802.11n	OFDM	40	15.0	13.95	-	0 mm	1TU8Q	13.5	front	93.0	1.170	-	1.274	1.075	-	
5510	102	802.11n	OFDM	40	15.0	13.95	-	0 mm	1TU8Q	13.5	top	93.0	0.628	-	1.274	1.075	-	
5510	102	802.11n	OFDM	40	15.0	13.95	-	0 mm	1TU8Q	13.5	right	93.0	1.970	-	1.274	1.075	-	
ANSI / IEEE C95.1 1992 - SAFETY LIMIT Spatial Peak Uncontrolled Exposure/General Population								Extremity 4.0 W/kg (mW/g) averaged over 10 grams										

FCC ID: ZNFH636		SAR EVALUATION REPORT		Reviewed by: Quality Manager
Document S/N: 0Y1503170617.ZNF	Test Dates: 03/17/15 - 04/20/15	DUT Type: Portable Handset		Page 63 of 77



**Table 11-26
Bluetooth Extremity SAR**

MEASUREMENT RESULTS															
FREQUENCY		Mode	Service	Maximum Allowed Power [dBm]	Conducted Power [dBm]	Power Drift [dB]	Spacing	Device Serial Number	Data Rate (Mbps)	Side	Duty Cycle	SAR (10g)	Scaling Factor	Scaled SAR (10g)	Plot #
MHz	Ch.											(W/kg)		(W/kg)	
2441	39	Bluetooth	FHSS	10.0	9.40	0.01	0 mm	1MKUW	1	back	1:1	0.035	1.148	0.040	A31
2441	39	Bluetooth	FHSS	10.0	9.40	0.05	0 mm	1MKUW	1	front	1:1	0.023	1.148	0.026	
2441	39	Bluetooth	FHSS	10.0	9.40	-0.15	0 mm	1MKUW	1	top	1:1	0.014	1.148	0.016	
2441	39	Bluetooth	FHSS	10.0	9.40	0.16	0 mm	1MKUW	1	right	1:1	0.020	1.148	0.023	
ANSI / IEEE C95.1 1992 - SAFETY LIMIT Spatial Peak Uncontrolled Exposure/General Population							Hand 4.0 W/kg (mW/g) averaged over 10 grams								

11.5 SAR Test Notes

General Notes:

1. The test data reported are the worst-case SAR values according to test procedures specified in IEEE 1528-2003, and FCC KDB Publication 447498 D01v05.
2. Batteries are fully charged at the beginning of the SAR measurements.
3. Liquid tissue depth was at least 15.0 cm for all frequencies.
4. The manufacturer has confirmed that the device(s) tested have the same physical, mechanical and thermal characteristics and are within operational tolerances expected for production units.
5. SAR results were scaled to the maximum allowed power to demonstrate compliance per FCC KDB Publication 447498 D01v05.
6. Device was tested using a fixed spacing for body-worn accessory testing. A separation distance of 10 mm was considered because the manufacturer has determined that there will be body-worn accessories available in the marketplace for users to support this separation distance.
7. Per FCC KDB Publication 648474 D04v01, body-worn SAR was evaluated without a headset connected to the device. Since the standalone reported body-worn SAR was ≤ 1.2 W/kg, no additional body-worn SAR evaluations using a headset cable were required.
8. Per FCC KDB 865664 D01 v01, variability SAR tests were performed when the measured SAR results for a frequency band were greater than 0.8 W/kg. Repeated SAR measurements are highlighted in the tables above for clarity. Please see Section 13 for variability analysis.
9. During SAR Testing for the Wireless Router conditions per FCC KDB Publication 941225 D06v02, the actual Portable Hotspot operation (with actual simultaneous transmission of a transmitter with WIFI) was not activated (See Section 6.6 for more details).
10. Per FCC KDB Publication 648474 D04v01r01, this device is considered a "phablet" since the diagonal dimension is > 160 mm and < 200 mm. Therefore, extremity SAR tests are required when wireless router mode does not apply or if wireless router 1g SAR > 1.2 W/kg.

FCC ID: ZNFH636	 PCTEST <small>ENGINEERING LABORATORY, INC.</small>	SAR EVALUATION REPORT		Reviewed by: Quality Manager
Document S/N: 0Y1503170617.ZNF	Test Dates: 03/17/15 - 04/20/15	DUT Type: Portable Handset		Page 64 of 77

GSM Test Notes:



1. Body-Worn accessory testing is typically associated with voice operations. Therefore, GSM voice was evaluated for body-worn SAR. GPRS was additionally evaluated for head and body-worn voice calls to cover VoIP.
2. Justification for reduced test configurations per KDB Publication 941225 D01v03 and October 2013 TCB Workshop Notes: The source-based frame-averaged output power was evaluated for all GPRS/EDGE slot configurations. The configuration with the highest target frame averaged output power was evaluated for SAR. When the maximum frame-averaged powers are equivalent across two or more slots (within 0.25 dB), the configuration with the most number of time slots was tested.
3. Per FCC KDB Publication 447498 D01v05, if the reported (scaled) SAR measured at the middle channel or highest output power channel for each test configuration is ≤ 0.8 W/kg then testing at the other channels is not required for such test configuration(s). When the maximum output power variation across the required test channels is $> \frac{1}{2}$ dB, instead of the middle channel, the highest output power channel was used.

UMTS Notes:

1. UMTS mode in was tested under RMC 12.2 kbps with HSPA Inactive per KDB Publication 941225 D01v03. HSPA SAR was not required since the average output power of the HSPA subtests was not more than 0.25 dB higher than the RMC level and SAR was less than 1.2 W/kg.
2. Per FCC KDB Publication 447498 D01v05, if the reported (scaled) SAR measured at the middle channel or highest output power channel for each test configuration is ≤ 0.8 W/kg then testing at the other channels is not required for such test configuration(s). When the maximum output power variation across the required test channels is $> \frac{1}{2}$ dB, instead of the middle channel, the highest output power channel was used.



LTE Notes:

1. LTE Considerations: LTE test configurations are determined according to SAR Evaluation Considerations for LTE Devices in FCC KDB Publication 941225 D05v02r03. The general test procedures used for testing can be found in Section 8.5.4.
2. MPR is permanently implemented for this device by the manufacturer. The specific manufacturer target MPR is indicated alongside the SAR results. MPR is enabled for this device, according to 3GPP TS36.101 Section 6.2.3 – 6.2.5 under Table 6.2.3-1.
3. A-MPR was disabled for all SAR tests by setting NS=01 on the base station simulator. SAR tests were performed with the same number of RB and RB offsets transmitting on all TTI frames (maximum TTI).

FCC ID: ZNFH636	 SAR EVALUATION REPORT 		Reviewed by: Quality Manager
Document S/N: 0Y1503170617.ZNF	Test Dates: 03/17/15 - 04/20/15	DUT Type: Portable Handset	Page 65 of 77

BT/WLAN Notes:

1. For held-to-ear and hotspot operations, the initial test position procedures were applied. The test position with the highest extrapolated peak SAR will be used as the initial test position. When reported SAR for the initial test position is ≤ 0.4 W/kg, no additional testing for the remaining test positions was required. Otherwise, SAR is evaluated at the subsequent highest peak SAR positions until the reported SAR result is ≤ 0.8 W/kg or all test positions are measured.
2. Justification for test configurations for WLAN per KDB Publication 248227 D01v02 for 2.4 GHz WIFI operations, the highest measured maximum output power channel for DSSS was selected for SAR measurement. SAR for OFDM modes (2.4 GHz 802.11g/n) was not required due to the maximum allowed powers and the highest reported DSSS SAR. See Section 8.6.5 for more information.
3. Justification for test configurations for WLAN per KDB Publication 248227 D01v02 for 5 GHz WIFI operations, the initial test configuration was selected according to the transmission mode with the highest maximum allowed powers. Other transmission modes were not investigated since the highest reported SAR for initial test configuration adjusted by the ratio of maximum output powers is less than 1.2 W/kg. See Section 8.6.6 for more information.
4. When the maximum reported 1g averaged SAR is ≤ 0.8 W/kg, SAR testing on additional channels was not required. Otherwise, SAR for the next highest output power channel was required until the reported SAR result was ≤ 1.20 W/kg or all test channels were measured.
5. The device was configured to transmit continuously at the required data rate, channel bandwidth and signal modulation, using the highest transmission duty factor supported by the test mode tools. The reported SAR was scaled to the 100% transmission duty factor to determine compliance. Procedures used to measure the duty factor are identical to that in the associated EMC test reports.
6. When Hotspot is enabled, U-NII-1, U-NII-2A, and U-NII-2C are disabled. Therefore no U-NII-1, U-NII-2A, and U-NII-2C WIFI Wireless Router SAR Data was required.
7. The channel and data rate with the highest average output power were evaluated for Bluetooth.

FCC ID: ZNFH636	 SAR EVALUATION REPORT 		Reviewed by: Quality Manager
Document S/N: 0Y1503170617.ZNF	Test Dates: 03/17/15 - 04/20/15	DUT Type: Portable Handset	Page 66 of 77

12 FCC MULTI-TX AND ANTENNA SAR CONSIDERATIONS

12.1 Introduction



The following procedures adopted from FCC KDB Publication 447498 D01v05 are applicable to handsets with built-in unlicensed transmitters such as 802.11a/b/g/n and Bluetooth devices which may simultaneously transmit with the licensed transmitter.

12.2 Simultaneous Transmission Procedures

This device contains transmitters that may operate simultaneously. Therefore simultaneous transmission analysis is required. Per FCC KDB 447498 D01v05 IV.C.1.iii and IEEE 1528-2013 Section 6.3.4.1.2, simultaneous transmission SAR test exclusion may be applied when the sum of the 1-g SAR for all the simultaneous transmitting antennas in a specific physical test configuration is ≤ 1.6 W/kg. The different test positions in an exposure condition may be considered collectively to determine SAR test exclusion according to the sum of 1-g or 10-g SAR.

Held-to ear configurations are not applicable to Bluetooth operations and therefore were not considered for simultaneous transmission.

Main antenna SAR testing was not required for extremity exposure conditions per FCC KDB 648474. Therefore, no further analysis was required to determine that possible simultaneous scenarios would not exceed the SAR limit.

FCC ID: ZNFH636	 PCTEST ENGINEERING LABORATORY, INC.	SAR EVALUATION REPORT	 LG	Reviewed by: Quality Manager
Document S/N: 0Y1503170617.ZNF	Test Dates: 03/17/15 - 04/20/15	DUT Type: Portable Handset		Page 67 of 77

12.3 Head SAR Simultaneous Transmission Analysis



Table 12-1
Simultaneous Transmission Scenario with 2.4 GHz WLAN (Held to Ear)

Exposure Condition	Mode	2G/3G/4G SAR (W/kg)	2.4 GHz WLAN SAR (W/kg)	Σ SAR (W/kg)
Head SAR	GSM 850	0.362	0.243	0.605
	GPRS 850	0.350	0.243	0.593
	GSM 1900	0.285	0.243	0.528
	GPRS 1900	0.319	0.243	0.562
	UMTS 850	0.477	0.243	0.720
	UMTS 1750	0.629	0.243	0.872
	UMTS 1900	0.663	0.243	0.906
	LTE Band 12	0.380	0.243	0.623
	LTE Band 5	0.425	0.243	0.668
	LTE Band 4	0.585	0.243	0.828
	LTE Band 2	0.539	0.243	0.782
	LTE Band 7	0.118	0.243	0.361

Table 12-2
Simultaneous Transmission Scenario with 5 GHz WLAN (Held to Ear)

Exposure Condition	Mode	2G/3G/4G SAR (W/kg)	5 GHz WLAN SAR (W/kg)	Σ SAR (W/kg)
Head SAR	GSM 850	0.362	0.358	0.720
	GPRS 850	0.350	0.358	0.708
	GSM 1900	0.285	0.358	0.643
	GPRS 1900	0.319	0.358	0.677
	UMTS 850	0.477	0.358	0.835
	UMTS 1750	0.629	0.358	0.987
	UMTS 1900	0.663	0.358	1.021
	LTE Band 12	0.380	0.358	0.738
	LTE Band 5	0.425	0.358	0.783
	LTE Band 4	0.585	0.358	0.943
	LTE Band 2	0.539	0.358	0.897
	LTE Band 7	0.118	0.358	0.476

The worst case 5 GHz WIFI reported SAR for each head configuration was considered for simultaneous SAR exclusion via summation of standalone SAR, regardless of whether the WIFI channel has WIFI Hotspot capability, for simplicity to determine compliance. Please note that the actual simultaneous transmission SAR will not exceed the summed levels indicated.

FCC ID: ZNFH636	 SAR EVALUATION REPORT 		Reviewed by: Quality Manager
Document S/N: 0Y1503170617.ZNF	Test Dates: 03/17/15 - 04/20/15	DUT Type: Portable Handset	Page 68 of 77

12.4 Body-Worn Simultaneous Transmission Analysis

Table 12-3
Simultaneous Transmission Scenario with 2.4 GHz WLAN (Body-Worn at 1.0 cm)

Configuration	Mode	2G/3G/4G SAR (W/kg)	2.4 GHz WLAN SAR (W/kg)	Σ SAR (W/kg)
Back Side	GSM 850	0.421	0.095	0.516
Back Side	GPRS 850	0.403	0.095	0.498
Back Side	GSM 1900	0.383	0.095	0.478
Back Side	GPRS 1900	0.416	0.095	0.511
Back Side	UMTS 850	0.645	0.095	0.740
Back Side	UMTS 1750	0.724	0.095	0.819
Back Side	UMTS 1900	0.783	0.095	0.878
Back Side	LTE Band 12	0.763	0.095	0.858
Back Side	LTE Band 5 (Cell)	0.580	0.095	0.675
Back Side	LTE Band 4 (AWS)	0.857	0.095	0.952
Back Side	LTE Band 2 (PCS)	0.741	0.095	0.836
Back Side	LTE Band 7	0.418	0.095	0.513



Table 12-4
Simultaneous Transmission Scenario with 5 GHz WLAN (Body-Worn at 1.0 cm)

Configuration	Mode	2G/3G/4G SAR (W/kg)	5 GHz WLAN SAR (W/kg)	Σ SAR (W/kg)
Back Side	GSM 850	0.421	0.124	0.545
Back Side	GPRS 850	0.403	0.124	0.527
Back Side	GSM 1900	0.383	0.124	0.507
Back Side	GPRS 1900	0.416	0.124	0.540
Back Side	UMTS 850	0.645	0.124	0.769
Back Side	UMTS 1750	0.724	0.124	0.848
Back Side	UMTS 1900	0.783	0.124	0.907
Back Side	LTE Band 12	0.763	0.124	0.887
Back Side	LTE Band 5 (Cell)	0.580	0.124	0.704
Back Side	LTE Band 4 (AWS)	0.857	0.124	0.981
Back Side	LTE Band 2 (PCS)	0.741	0.124	0.865
Back Side	LTE Band 7	0.418	0.124	0.542

The worst case 5 GHz WIFI reported SAR for each body-worn configuration was considered for simultaneous SAR exclusion via summation of standalone SAR, regardless of whether the WIFI channel has WIFI Hotspot capability, for simplicity to determine compliance. Please note that the actual simultaneous transmission SAR will not exceed the summed levels indicated.

Table 12-5
Simultaneous Transmission Scenario with Bluetooth (Body-Worn at 1.0 cm)

Configuration	Mode	2G/3G/4G SAR (W/kg)	Bluetooth SAR (W/kg)	Σ SAR (W/kg)
Back Side	GSM 850	0.421	0.011	0.432
Back Side	GPRS 850	0.403	0.011	0.414
Back Side	GSM 1900	0.383	0.011	0.394
Back Side	GPRS 1900	0.416	0.011	0.427
Back Side	UMTS 850	0.645	0.011	0.656
Back Side	UMTS 1750	0.724	0.011	0.735
Back Side	UMTS 1900	0.783	0.011	0.794
Back Side	LTE Band 12	0.763	0.011	0.774
Back Side	LTE Band 5 (Cell)	0.580	0.011	0.591
Back Side	LTE Band 4 (AWS)	0.857	0.011	0.868
Back Side	LTE Band 2 (PCS)	0.741	0.011	0.752
Back Side	LTE Band 7	0.418	0.011	0.429

FCC ID: ZNFH636	 SAR EVALUATION REPORT 		Reviewed by: Quality Manager
Document S/N: 0Y1503170617.ZNF	Test Dates: 03/17/15 - 04/20/15	DUT Type: Portable Handset	Page 69 of 77

12.5 Hotspot SAR Simultaneous Transmission Analysis

Per FCC KDB Publication 941225 D06v02, the devices edges with antennas more than 2.5 cm from edge are not required to be evaluated for SAR (“-”).

Table 12-6
Simultaneous Transmission Scenario with 2.4 GHz WLAN (Hotspot at 1.0 cm)



Exposure Condition	Mode	2G/3G/4G SAR (W/kg)	2.4 GHz WLAN SAR (W/kg)	Σ SAR (W/kg)
Hotspot SAR	GPRS 850	0.546	0.095	0.641
	GPRS 1900	0.416	0.095	0.511
	UMTS 850	0.764	0.095	0.859
	UMTS 1750	0.796	0.095	0.891
	UMTS 1900	0.783	0.095	0.878
	LTE Band 12	0.763	0.095	0.858
	LTE Band 5	0.709	0.095	0.804
	LTE Band 4	0.857	0.095	0.952
	LTE Band 2	0.741	0.095	0.836
LTE Band 7	0.418	0.095	0.513	

Table 12-7
Simultaneous Transmission Scenario with 5 GHz WLAN (Hotspot at 1.0 cm)

Exposure Condition	Mode	2G/3G/4G SAR (W/kg)	5 GHz WLAN SAR (W/kg)	Σ SAR (W/kg)
Hotspot SAR	GPRS 850	0.546	0.124	0.670
	GPRS 1900	0.416	0.124	0.540
	UMTS 850	0.764	0.124	0.888
	UMTS 1750	0.796	0.124	0.920
	UMTS 1900	0.783	0.124	0.907
	LTE Band 12	0.763	0.124	0.887
	LTE Band 5	0.709	0.124	0.833
	LTE Band 4	0.857	0.124	0.981
	LTE Band 2	0.741	0.124	0.865
LTE Band 7	0.418	0.124	0.542	

12.6 Simultaneous Transmission Conclusion

The above numerical summed SAR results for all the worst-case simultaneous transmission conditions were below the SAR limit. Therefore, the above analysis is sufficient to determine that simultaneous transmission cases will not exceed the SAR limit and therefore no measured volumetric simultaneous SAR summation is required per FCC KDB Publication 447498 D01v05 and IEEE 1528-2013 Section 6.3.4.1.2.

FCC ID: ZNFH636	 SAR EVALUATION REPORT 		Reviewed by: Quality Manager
Document S/N: 0Y1503170617.ZNF	Test Dates: 03/17/15 - 04/20/15	DUT Type: Portable Handset	Page 70 of 77

13 SAR MEASUREMENT VARIABILITY

13.1 Measurement Variability

Per FCC KDB Publication 865664 D01v01, SAR measurement variability was assessed for each frequency band, which was determined by the SAR probe calibration point and tissue-equivalent medium used for the device measurements. When both head and body tissue-equivalent media were required for SAR measurements in a frequency band, the variability measurement procedures were applied to the tissue medium with the highest measured SAR, using the highest measured SAR configuration for that tissue-equivalent medium. These additional measurements were repeated after the completion of all measurements requiring the same head or body tissue-equivalent medium in a frequency band. The test device was returned to ambient conditions (normal room temperature) with the battery fully charged before it was re-mounted on the device holder for the repeated measurement(s) to minimize any unexpected variations in the repeated results.

SAR Measurement Variability was assessed using the following procedures for each frequency band:



- 1) When the original highest measured SAR is ≥ 0.80 W/kg, the measurement was repeated once.
- 2) A second repeated measurement was performed only if the ratio of largest to smallest SAR for the original and first repeated measurements was > 1.20 or when the original or repeated measurement was ≥ 1.45 W/kg (~ 10% from the 1-g SAR limit).
- 3) A third repeated measurement was performed only if the original, first or second repeated measurement was ≥ 1.5 W/kg and the ratio of largest to smallest SAR for the original, first and second repeated measurements is > 1.20 .
- 4) Repeated measurements are not required when the original highest measured SAR is < 0.80 W/kg

**Table 13-1
Body SAR Measurement Variability Results**

BODY VARIABILITY RESULTS													
Band	FREQUENCY		Mode	Service	Side	Spacing	Measured SAR (1g)	1st Repeated SAR (1g)	Ratio	2nd Repeated SAR (1g)	Ratio	3rd Repeated SAR (1g)	Ratio
	MHz	Ch.					(W/kg)	(W/kg)		(W/kg)		(W/kg)	
1750	1732.50	20175	LTE Band 4 (AWS)	QPSK, 1 RB, 0 RB Offset	back	10 mm	0.808	0.838	1.04	N/A	N/A	N/A	N/A
ANSI / IEEE C95.1 1992 - SAFETY LIMIT Spatial Peak Uncontrolled Exposure/General Population						Body 1.6 W/kg (mW/g) averaged over 1 gram							

13.2 Measurement Uncertainty

The measured SAR was < 1.5 W/kg for all frequency bands. Therefore, per KDB Publication 865664 D01v01, the extended measurement uncertainty analysis per IEEE 1528-2003 was not required.



FCC ID: ZNFH636	 PCTEST ENGINEERING LABORATORY, INC.	SAR EVALUATION REPORT	 LG	Reviewed by: Quality Manager
Document S/N: 0Y1503170617.ZNF	Test Dates: 03/17/15 - 04/20/15	DUT Type: Portable Handset	Page 71 of 77	

14 EQUIPMENT LIST

Manufacturer	Model	Description	Cal Date	Cal Interval	Cal Due	Serial Number
Gigatronics	80701A	(0.05-18GHz) Power Sensor	10/30/2014	Annual	10/30/2015	1833460
Agilent	E4438C	Signal Generator	2/13/2014	Biennial	2/13/2016	MY49070494
Agilent	8753E	(30kHz-6GHz) Network Analyzer	12/30/2014	Annual	12/30/2015	JP38020182
Agilent	8594A	(9kHz-2.9GHz) Spectrum Analyzer	N/A	N/A	N/A	3051A00187
Agilent	E4438C	Signal Generator	3/5/2015	Biennial	3/5/2017	MY49070496
SPEAG	D750V3	750 MHz Dipole	1/16/2015	Annual	1/16/2016	1003
SPEAG	D835V2	835 MHz SAR Dipole	7/24/2014	Annual	7/24/2015	4d133
SPEAG	D835V2	835 MHz SAR Dipole	1/16/2015	Annual	1/16/2016	4d132
SPEAG	D1750V2	1750 MHz SAR Dipole	4/10/2014	Annual	4/10/2015	1051
SPEAG	D1900V2	1900 MHz SAR Dipole	4/9/2014	Annual	4/9/2015	504141
SPEAG	D2450V2	2450 MHz SAR Dipole	8/11/2014	Annual	8/11/2015	719
SPEAG	D2450V2	2450 MHz SAR Dipole	2/18/2015	Annual	2/18/2016	882
SPEAG	D5GHzV2	5 GHz SAR Dipole	1/21/2015	Annual	1/21/2016	1057
SPEAG	D5GHzV2	5 GHz SAR Dipole	9/25/2014	Annual	9/25/2015	1191
SPEAG	ES3DV3	SAR Probe	5/15/2014	Annual	5/15/2015	3263
SPEAG	ES3DV2	SAR Probe	8/19/2014	Annual	8/19/2015	3022
SPEAG	ES3DV3	SAR Probe	9/24/2014	Annual	9/24/2015	3288
SPEAG	ES3DV3	SAR Probe	10/24/2014	Annual	10/24/2015	3333
SPEAG	EX3DV4	SAR Probe	12/12/2014	Annual	12/12/2015	3920
SPEAG	ES3DV3	SAR Probe	12/16/2014	Annual	12/16/2015	3334
SPEAG	ES3DV3	SAR Probe	1/20/2015	Annual	1/20/2016	3213
SPEAG	EX3DV4	SAR Probe	2/10/2015	Annual	2/10/2016	3914
SPEAG	DAE4	Dasy Data Acquisition Electronics	5/14/2014	Annual	5/14/2015	859
SPEAG	DAE4	Dasy Data Acquisition Electronics	8/12/2014	Annual	8/12/2015	1322
SPEAG	DAE4	Dasy Data Acquisition Electronics	9/18/2014	Annual	9/18/2015	1364
SPEAG	DAE4	Dasy Data Acquisition Electronics	10/23/2014	Annual	10/23/2015	1408
SPEAG	DAE4	Dasy Data Acquisition Electronics	10/31/2014	Annual	10/31/2015	1333
SPEAG	DAE4	Dasy Data Acquisition Electronics	12/12/2014	Annual	12/12/2015	1415
SPEAG	DAE4	Dasy Data Acquisition Electronics	2/18/2015	Annual	2/18/2016	665
SPEAG	DAE4	Dasy Data Acquisition Electronics	1/19/2015	Annual	1/19/2016	1407
Rohde & Schwarz	CMU200	Base Station Simulator	6/6/2014	Annual	6/6/2015	109892
Rohde & Schwarz	CMU200	Base Station Simulator	12/4/2014	Annual	12/4/2015	833855/0010
SPEAG	DAK-3.5	Dielectric Assessment Kit	5/6/2014	Annual	5/6/2015	1070
Mitutoyo	CD-6"CSX	Digital Caliper	5/8/2014	Biennial	5/8/2016	13264162
Fisher Scientific	15-077-960	Digital Thermometer	12/4/2013	Biennial	12/4/2015	130764558
Agilent	E4438C	ESG Vector Signal Generator	3/4/2015	Biennial	3/4/2017	MY45090555
Agilent	E4438C	ESG Vector Signal Generator	10/24/2014	Biennial	10/24/2016	MY44270752
Control Company	4052	Long Stem Thermometer	9/27/2013	Biennial	9/27/2015	130567447
SPEAG	DAKS-3.5	Portable Dielectric Assessment Kit	7/15/2014	Annual	7/15/2015	1039
Anritsu	MA2411B	Pulse Power Sensor	11/17/2014	Annual	11/17/2015	1207364
Anritsu	MA2411B	Pulse Power Sensor	11/17/2014	Annual	11/17/2015	1126066
Anritsu	ML2495A	Power Meter	10/31/2013	Biennial	10/31/2015	0941001
Anritsu	ML2495A	Power Meter	10/31/2013	Biennial	10/31/2015	1039008
Anritsu	MT8820C	Radio Communication Analyzer	5/6/2014	Annual	5/6/2015	6201144419
Anritsu	MT8820C	Radio Communication Analyzer	8/28/2014	Annual	8/28/2015	6201240328
Rohde & Schwarz	CMW500	Radio Communication Tester	10/4/2013	Biennial	10/4/2015	103962
Tektronix	RSA6114A	Real Time Spectrum Analyzer	4/16/2014	Annual	4/16/2015	8010177
Agilent	8753ES	S-Parameter Network Analyzer	1/20/2015	Annual	1/20/2016	US39170122
Agilent	N9020A	MXA Signal Analyzer	10/27/2014	Annual	10/27/2015	US46470561
Rohde & Schwarz	CMU200	Base Station Simulator	6/6/2014	Annual	6/6/2015	109892
Control Company	4040	Thermometer	8/5/2013	Biennial	8/5/2015	130448366
Seekonk	NC-100	Torque Wrench 5/16", 8" lbs	3/18/2014	Biennial	3/18/2016	N/A
Gigatronics	8651A	Universal Power Meter	10/30/2014	Annual	10/30/2015	8650319
Control Company	36934-158	Wall-Mounted Thermometer	4/29/2014	Biennial	4/29/2016	122014488
Agilent	E5515C	Wireless Communications Test Set	5/9/2013	Biennial	5/9/2015	GB43304447
Agilent	E5515C	Wireless Communications Test Set	8/9/2014	Annual	8/9/2015	GB43304278
Agilent	N4010A	Wireless Connectivity Test Set	N/A	N/A	N/A	GB44450273
MiniCircuits	VLF-6000+	Low Pass Filter	CBT	N/A	CBT	N/A
MiniCircuits	SLP-2400+	Low Pass Filter	CBT	N/A	CBT	R8979500903
Mini-Circuits	NLP-1200+	Low Pass Filter DC to 1000 MHz	CBT	N/A	CBT	N/A
Mini-Circuits	NLP-2950+	Low Pass Filter DC to 2700 MHz	CBT	N/A	CBT	N/A
Pasternack	PE2208-6	Bidirectional Coupler	CBT	N/A	CBT	N/A
Pasternack	PE2209-10	Bidirectional Coupler	CBT	N/A	CBT	N/A
Narda	4014C-6	4 - 8 GHz SMA 6 dB Directional Coupler	CBT	N/A	CBT	N/A
Mini-Circuits	BW-N20W5+	DC to 18 GHz Precision Fixed 20 dB Attenuator	CBT	N/A	CBT	N/A
Mini-Circuits	BW-N20W5	Power Attenuator	CBT	N/A	CBT	1226
MCL	BW-N6W5+	6dB Attenuator	CBT	N/A	CBT	1139
Narda	4772-3	Attenuator (3dB)	CBT	N/A	CBT	9406
Amplifier Research	1551G6	Amplifier	CBT	N/A	CBT	433971
Amplifier Research	1551G6	Amplifier	CBT	N/A	CBT	433972

Note:

1. CBT (Calibrated Before Testing). Prior to testing, the measurement paths containing a cable, amplifier, attenuator, coupler or filter were connected to a calibrated source (i.e. a signal generator) to determine the losses of the measurement path. The power meter offset was then adjusted to compensate for the measurement system losses. This level offset is stored within the power meter before measurements are made. This calibration verification procedure applies to the system verification and output power measurements. The calibrated reading is then taken directly from the power meter after compensation of the losses for all final power measurements.
2. Each equipment item was used solely within its respective calibration period.



FCC ID: ZNFH636	 SAR EVALUATION REPORT 		Reviewed by: Quality Manager
Document S/N: 0Y1503170617.ZNF	Test Dates: 03/17/15 - 04/20/15	DUT Type: Portable Handset	Page 72 of 77

15 MEASUREMENT UNCERTAINTIES

Applicable for frequencies less than 3000 MHz.

a	b	c	d	e= f(d,k)	f	g	h = c x f/e	i = c x g/e	k
Uncertainty Component	IEEE 1528 Sec.	Tol. (± %)	Prob. Dist.	Div.	c _i 1gm	c _i 10 gms	1gm u _i (± %)	10gms u _i (± %)	v _i
Measurement System									
Probe Calibration	E.2.1	6.0	N	1	1.0	1.0	6.0	6.0	∞
Axial Isotropy	E.2.2	0.25	N	1	0.7	0.7	0.2	0.2	∞
Hemishperical Isotropy	E.2.2	1.3	N	1	1.0	1.0	1.3	1.3	∞
Boundary Effect	E.2.3	0.4	N	1	1.0	1.0	0.4	0.4	∞
Linearity	E.2.4	0.3	N	1	1.0	1.0	0.3	0.3	∞
System Detection Limits	E.2.5	5.1	N	1	1.0	1.0	5.1	5.1	∞
Readout Electronics	E.2.6	1.0	N	1	1.0	1.0	1.0	1.0	∞
Response Time	E.2.7	0.8	R	1.73	1.0	1.0	0.5	0.5	∞
Integration Time	E.2.8	2.6	R	1.73	1.0	1.0	1.5	1.5	∞
RF Ambient Conditions	E.6.1	3.0	R	1.73	1.0	1.0	1.7	1.7	∞
Probe Positioner Mechanical Tolerance	E.6.2	0.4	R	1.73	1.0	1.0	0.2	0.2	∞
Probe Positioning w/ respect to Phantom	E.6.3	2.9	R	1.73	1.0	1.0	1.7	1.7	∞
Extrapolation, Interpolation & Integration algorithms for Max. SAR Evaluation	E.5	1.0	R	1.73	1.0	1.0	0.6	0.6	∞
Test Sample Related									
Test Sample Positioning	E.4.2	6.0	N	1	1.0	1.0	6.0	6.0	287
Device Holder Uncertainty	E.4.1	3.32	R	1.73	1.0	1.0	1.9	1.9	∞
Output Power Variation - SAR drift measurement	6.6.2	5.0	R	1.73	1.0	1.0	2.9	2.9	∞
Phantom & Tissue Parameters									
Phantom Uncertainty (Shape & Thickness tolerances)	E.3.1	4.0	R	1.73	1.0	1.0	2.3	2.3	∞
Liquid Conductivity - deviation from target values	E.3.2	5.0	R	1.73	0.64	0.43	1.8	1.2	∞
Liquid Conductivity - measurement uncertainty	E.3.3	3.8	N	1	0.64	0.43	2.4	1.6	6
Liquid Permittivity - deviation from target values	E.3.2	5.0	R	1.73	0.60	0.49	1.7	1.4	∞
Liquid Permittivity - measurement uncertainty	E.3.3	4.5	N	1	0.60	0.49	2.7	2.2	6
Combined Standard Uncertainty (k=1)	RSS						12.1	11.7	299
Expanded Uncertainty (95% CONFIDENCE LEVEL)	k=2						24.2	23.5	



The above measurement uncertainties are according to IEEE Std. 1528-2003

FCC ID: ZNFH636	 SAR EVALUATION REPORT			Reviewed by: Quality Manager
Document S/N: 0Y1503170617.ZNF	Test Dates: 03/17/15 - 04/20/15	DUT Type: Portable Handset		Page 73 of 77

Applicable for frequencies up to 6 GHz.

a	b	c	d	e= f(d,k)	f	g	h= c x f/e	i= c x g/e	k
Uncertainty Component	IEEE 1528 Sec.	Tol. (± %)	Prob. Dist.	Div.	c _i 1gm	c _i 10 gms	1gm u _i (± %)	10gms u _i (± %)	v _i
Measurement System									
Probe Calibration	E.2.1	6.55	N	1	1.0	1.0	6.6	6.6	∞
Axial Isotropy	E.2.2	0.25	N	1	0.7	0.7	0.2	0.2	∞
Hemishperical Isotropy	E.2.2	1.3	N	1	1.0	1.0	1.3	1.3	∞
Boundary Effect	E.2.3	0.4	N	1	1.0	1.0	0.4	0.4	∞
Linearity	E.2.4	0.3	N	1	1.0	1.0	0.3	0.3	∞
System Detection Limits	E.2.5	5.1	N	1	1.0	1.0	5.1	5.1	∞
Readout Electronics	E.2.6	1.0	N	1	1.0	1.0	1.0	1.0	∞
Response Time	E.2.7	0.8	R	1.73	1.0	1.0	0.5	0.5	∞
Integration Time	E.2.8	2.6	R	1.73	1.0	1.0	1.5	1.5	∞
RF Ambient Conditions	E.6.1	3.0	R	1.73	1.0	1.0	1.7	1.7	∞
Probe Positioner Mechanical Tolerance	E.6.2	0.4	R	1.73	1.0	1.0	0.2	0.2	∞
Probe Positioning w/ respect to Phantom	E.6.3	2.9	R	1.73	1.0	1.0	1.7	1.7	∞
Extrapolation, Interpolation & Integration algorithms for Max. SAR Evaluation	E.5	1.0	R	1.73	1.0	1.0	0.6	0.6	∞
Test Sample Related									
Test Sample Positioning	E.4.2	6.0	N	1	1.0	1.0	6.0	6.0	287
Device Holder Uncertainty	E.4.1	3.32	R	1.73	1.0	1.0	1.9	1.9	∞
Output Power Variation - SAR drift measurement	6.6.2	5.0	R	1.73	1.0	1.0	2.9	2.9	∞
Phantom & Tissue Parameters									
Phantom Uncertainty (Shape & Thickness tolerances)	E.3.1	4.0	R	1.73	1.0	1.0	2.3	2.3	∞
Liquid Conductivity - deviation from target values	E.3.2	5.0	R	1.73	0.64	0.43	1.8	1.2	∞
Liquid Conductivity - measurement uncertainty	E.3.3	3.8	N	1	0.64	0.43	2.4	1.6	6
Liquid Permittivity - deviation from target values	E.3.2	5.0	R	1.73	0.60	0.49	1.7	1.4	∞
Liquid Permittivity - measurement uncertainty	E.3.3	4.5	N	1	0.60	0.49	2.7	2.2	6
Combined Standard Uncertainty (k=1)	RSS						12.4	12.0	299
Expanded Uncertainty (95% CONFIDENCE LEVEL)	k=2						24.7	24.0	

The above measurement uncertainties are according to IEEE Std. 1528-2003



FCC ID: ZNFH636	 SAR EVALUATION REPORT			Reviewed by: Quality Manager
Document S/N: 0Y1503170617.ZNF	Test Dates: 03/17/15 - 04/20/15	DUT Type: Portable Handset		Page 74 of 77

16 CONCLUSION

16.1 Measurement Conclusion



The SAR evaluation indicates that the EUT complies with the RF radiation exposure limits of the FCC and Industry Canada, with respect to all parameters subject to this test. These measurements were taken to simulate the RF effects of RF exposure under worst-case conditions. Precise laboratory measures were taken to assure repeatability of the tests. The results and statements relate only to the item(s) tested.

Please note that the absorption and distribution of electromagnetic energy in the body are very complex phenomena that depend on the mass, shape, and size of the body, the orientation of the body with respect to the field vectors, and the electrical properties of both the body and the environment. Other variables that may play a substantial role in possible biological effects are those that characterize the environment (e.g. ambient temperature, air velocity, relative humidity, and body insulation) and those that characterize the individual (e.g. age, gender, activity level, debilitation, or disease). Because various factors may interact with one another to vary the specific biological outcome of an exposure to electromagnetic fields, any protection guide should consider maximal amplification of biological effects as a result of field-body interactions, environmental conditions, and physiological variables. [3]



FCC ID: ZNFH636	 PCTEST ENGINEERING LABORATORY, INC.	SAR EVALUATION REPORT	 LG	Reviewed by: Quality Manager
Document S/N: 0Y1503170617.ZNF	Test Dates: 03/17/15 - 04/20/15	DUT Type: Portable Handset		Page 75 of 77

17 REFERENCES

- [1] Federal Communications Commission, ET Docket 93-62, Guidelines for Evaluating the Environmental Effects of Radiofrequency Radiation, Aug. 1996.
- [2] ANSI/IEEE C95.1-2005, American National Standard safety levels with respect to human exposure to radio frequency electromagnetic fields, 3kHz to 300GHz, New York: IEEE, 2006.
- [3] ANSI/IEEE C95.1-1992, American National Standard safety levels with respect to human exposure to radio frequency electromagnetic fields, 3kHz to 300GHz, New York: IEEE, Sept. 1992.
- [4] ANSI/IEEE C95.3-2002, IEEE Recommended Practice for the Measurement of Potentially Hazardous Electromagnetic Fields - RF and Microwave, New York: IEEE, December 2002.
- [5] IEEE Standards Coordinating Committee 39 –Standards Coordinating Committee 34 – IEEE Std. 1528-2003, Recommended Practice for Determining the Peak Spatial-Average Specific Absorption Rate (SAR) in the Human Head Due to Wireless Communications Devices: Measurement Techniques.
- [6] NCRP, National Council on Radiation Protection and Measurements, Biological Effects and Exposure Criteria for RadioFrequency Electromagnetic Fields, NCRP Report No. 86, 1986. Reprinted Feb. 1995.
- [7] T. Schmid, O. Egger, N. Kuster, Automated E-field scanning system for dosimetric assessments, IEEE Transaction on Microwave Theory and Techniques, vol. 44, Jan. 1996, pp. 105-113.
- [8] K. Pokovic, T. Schmid, N. Kuster, Robust setup for precise calibration of E-field probes in tissue simulating liquids at mobile communications frequencies, ICECOM97, Oct. 1997, pp.1 -124.
- [9] K. Pokovic, T. Schmid, and N. Kuster, E-field Probe with improved isotropy in brain simulating liquids, Proceedings of the ELMAR, Zadar, Croatia, June 23-25, 1996, pp. 172-175.
- [10] Schmid & Partner Engineering AG, Application Note: Data Storage and Evaluation, June 1998, p2.
- [11] V. Hombach, K. Meier, M. Burkhardt, E. Kuhn, N. Kuster, The Dependence of EM Energy Absorption upon Human Modeling at 900 MHz, IEEE Transaction on Microwave Theory and Techniques, vol. 44 no. 10, Oct. 1996, pp. 1865-1873.
- [12] N. Kuster and Q. Balzano, Energy absorption mechanism by biological bodies in the near field of dipole antennas above 300MHz, IEEE Transaction on Vehicular Technology, vol. 41, no. 1, Feb. 1992, pp. 17-23.
- [13] G. Hartsgrrove, A. Kraszewski, A. Surowiec, Simulated Biological Materials for Electromagnetic Radiation Absorption Studies, University of Ottawa, Bioelectromagnetics, Canada: 1987, pp. 29-36.
- [14] Q. Balzano, O. Garay, T. Manning Jr., Electromagnetic Energy Exposure of Simulated Users of Portable Cellular Telephones, IEEE Transactions on Vehicular Technology, vol. 44, no.3, Aug. 1995.
- [15] W. Gander, Computermathematick, Birkhaeuser, Basel, 1992.
- [16] W.H. Press, S.A. Teukolsky, W.T. Vetterling, and B.P. Flannery, Numerical Recipes in C, The Art of Scientific Computing, Second edition, Cambridge University Press, 1992.
- [17] N. Kuster, R. Kastle, T. Schmid, Dosimetric evaluation of mobile communications equipment with known precision, IEEE Transaction on Communications, vol. E80-B, no. 5, May 1997, pp. 645-652.

FCC ID: ZNFH636	 SAR EVALUATION REPORT 		Reviewed by: Quality Manager
Document S/N: 0Y1503170617.ZNF	Test Dates: 03/17/15 - 04/20/15	DUT Type: Portable Handset	Page 76 of 77

- [18] CENELEC CLC/SC111B, European Prestandard (prENV 50166-2), Human Exposure to Electromagnetic Fields High-frequency: 10kHz-300GHz, Jan. 1995.
- [19] Prof. Dr. Niels Kuster, ETH, Eidgenössische Technische Hochschule Zürich, Dosimetric Evaluation of the Cellular Phone.
- [20] IEC 62209-1, Human exposure to radio frequency fields from hand-held and body-mounted wireless communication devices - Human models, instrumentation, and procedures - Part 1: Procedure to determine the specific absorption rate (SAR) for hand-held devices used in close proximity to the ear (frequency range of 300 MHz to 3 GHz), Feb. 2005.
- [21] Industry Canada RSS-102 Radio Frequency Exposure Compliance of Radiocommunication Apparatus (All Frequency Bands) Issue 4, March 2010.
- [22] Health Canada Safety Code 6 Limits of Human Exposure to Radio Frequency Electromagnetic Fields in the Frequency Range from 3 kHz – 300 GHz, 2009
- [23] FCC SAR Test Procedures for 2G-3G Devices, Mobile Hotspot and UMPC Devices KDB Publications 941225, D01-D06
- [24] SAR Measurement procedures for IEEE 802.11a/b/g KDB Publication 248227 D01v02
- [25] FCC SAR Considerations for Handsets with Multiple Transmitters and Antennas, KDB Publications 648474 D02-D04
- [26] FCC SAR Evaluation Considerations for Laptop, Notebook, Netbook and Tablet Computers, FCC KDB Publication 616217 D04
- [27] FCC SAR Measurement and Reporting Requirements for 100MHz – 6 GHz, KDB Publications 865664 D01-D02
- [28] FCC General RF Exposure Guidance and SAR Procedures for Dongles, KDB Publication 447498, D01-D02
- [29] Anexo à Resolução No. 533, de 10 de Setembro de 2009.
- [30] IEC 62209-2, Human exposure to radio frequency fields from hand-held and body-mounted wireless communication devices - Human models, instrumentation, and procedures - Part 2: Procedure to determine the specific absorption rate (SAR) for wireless communication devices used in close proximity to the human body (frequency range of 30 MHz to 6 GHz), Mar. 2010.

FCC ID: ZNFH636	 SAR EVALUATION REPORT 		Reviewed by: Quality Manager
Document S/N: 0Y1503170617.ZNF	Test Dates: 03/17/15 - 04/20/15	DUT Type: Portable Handset	Page 77 of 77

APPENDIX A: SAR TEST DATA

PCTEST ENGINEERING LABORATORY, INC.

DUT: ZNFH636; Type: Portable Handset; Serial: 1TU8L

Communication System: UID 0, GSM; Frequency: 836.6 MHz; Duty Cycle: 1:8.3
Medium: 835 Head Medium parameters used (interpolated):
 $f = 836.6 \text{ MHz}$; $\sigma = 0.9 \text{ S/m}$; $\epsilon_r = 40.26$; $\rho = 1000 \text{ kg/m}^3$
Phantom section: Right Section

Test Date: 03-25-2015; Ambient Temp: 22.8°C; Tissue Temp: 22.0°C

Probe: ES3DV3 - SN3288; ConvF(6.51, 6.51, 6.51); Calibrated: 9/24/2014;
Sensor-Surface: 3mm (Mechanical Surface Detection)
Electronics: DAE4 Sn1364; Calibrated: 9/18/2014
Phantom: SAM with CRP v4.0; Type: QD000P40CD; Serial: TP:1797
Measurement SW: DASY52, Version 52.8 (8); SEMCAD X Version 14.6.10 (7331)

Mode: GSM 850, Right Head, Cheek, Mid.ch

Area Scan (9x14x1): Measurement grid: dx=15mm, dy=15mm

Zoom Scan (5x5x7)/Cube 0: Measurement grid: dx=8mm, dy=8mm, dz=5mm

Reference Value = 19.93 V/m; Power Drift = 0.02 dB

Peak SAR (extrapolated) = 0.453 W/kg

SAR (1 g) = 0.355 W/kg

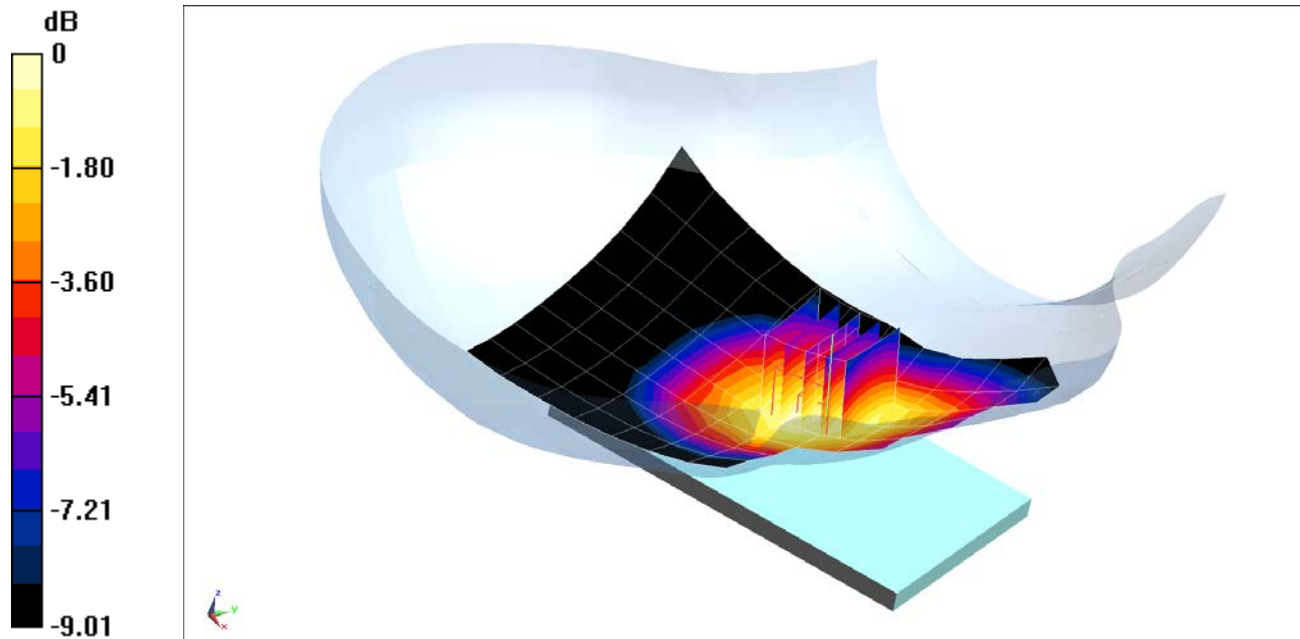

0 dB = 0.389 W/kg = -4.10 dBW/kg

PCTEST ENGINEERING LABORATORY, INC.

DUT: ZNFH636; Type: Portable Handset; Serial: 1TU8L

Communication System: UID 0, GSM GPRS; 3 Tx slots; Frequency: 1880 MHz; Duty Cycle: 1:2.76
Medium: 1900 Head Medium parameters used:
 $f = 1880 \text{ MHz}$; $\sigma = 1.409 \text{ S/m}$; $\epsilon_r = 40.048$; $\rho = 1000 \text{ kg/m}^3$
Phantom section: Left Section

Test Date: 03-23-2015; Ambient Temp: 22.6°C; Tissue Temp: 21.6°C

Probe: ES3DV3 - SN3213; ConvF(5.06, 5.06, 5.06); Calibrated: 1/20/2015;
Sensor-Surface: 3mm (Mechanical Surface Detection)
Electronics: DAE4 Sn1407; Calibrated: 1/19/2015
Phantom: SAM Front; Type: SAM; Serial: 1686
Measurement SW: DASY52, Version 52.8 (8); SEMCAD X Version 14.6.10 (7331)

Mode: GPRS 1900, Left Head, Cheek, Mid.ch, 3 Tx slots

Area Scan (9x15x1): Measurement grid: dx=15mm, dy=15mm
Zoom Scan (5x5x7)/Cube 0: Measurement grid: dx=8mm, dy=8mm, dz=5mm
Reference Value = 14.78 V/m; Power Drift = -0.18 dB
Peak SAR (extrapolated) = 0.448 W/kg
SAR (1 g) = 0.293 W/kg

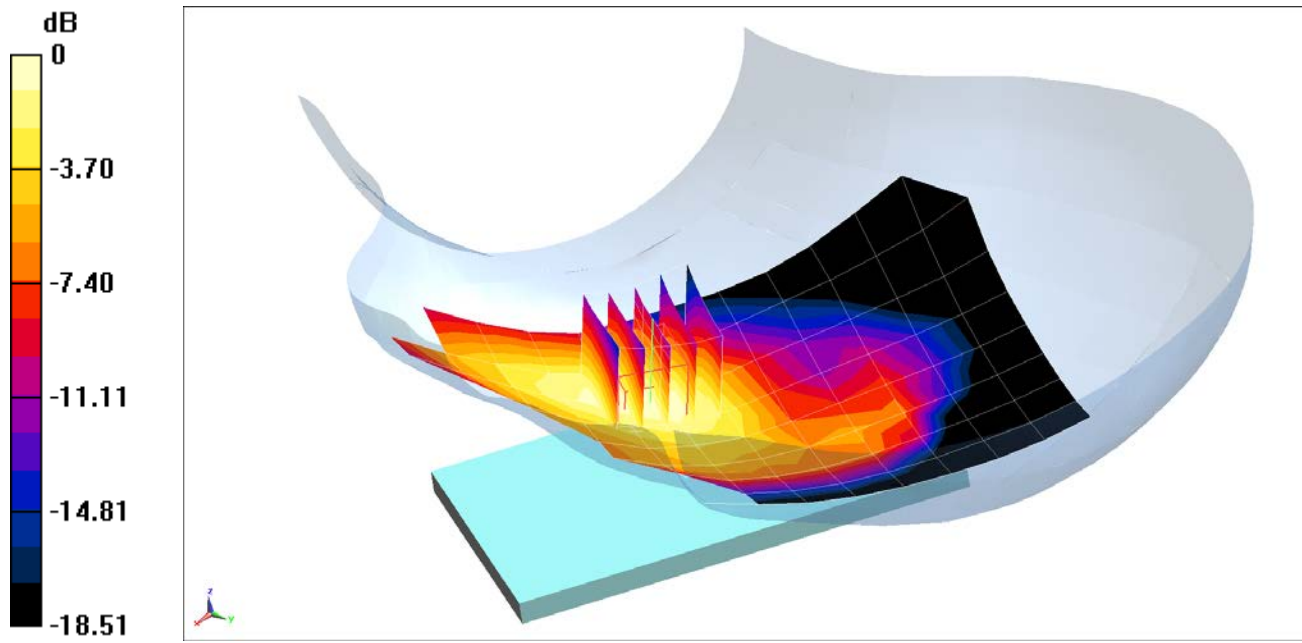

0 dB = 0.337 W/kg = -4.72 dBW/kg

PCTEST ENGINEERING LABORATORY, INC.

DUT: ZNFH636; Type: Portable Handset; Serial: 1TU8L

Communication System: UID 0, UMTS; Frequency: 836.6 MHz; Duty Cycle: 1:1
Medium: 835 Head Medium parameters used (interpolated):
 $f = 836.6 \text{ MHz}$; $\sigma = 0.9 \text{ S/m}$; $\epsilon_r = 40.26$; $\rho = 1000 \text{ kg/m}^3$
Phantom section: Right Section

Test Date: 03-25-2015; Ambient Temp: 22.8°C; Tissue Temp: 22.0°C

Probe: ES3DV3 - SN3288; ConvF(6.51, 6.51, 6.51); Calibrated: 9/24/2014;
Sensor-Surface: 3mm (Mechanical Surface Detection)
Electronics: DAE4 Sn1364; Calibrated: 9/18/2014
Phantom: SAM with CRP v4.0; Type: QD000P40CD; Serial: TP:1797
Measurement SW: DASY52, Version 52.8 (8); SEMCAD X Version 14.6.10 (7331)

Mode: UMTS 850, Right Head, Cheek, Mid.ch

Area Scan (9x14x1): Measurement grid: dx=15mm, dy=15mm

Zoom Scan (5x5x7)/Cube 0: Measurement grid: dx=8mm, dy=8mm, dz=5mm

Reference Value = 23.21 V/m; Power Drift = 0.01 dB

Peak SAR (extrapolated) = 0.609 W/kg

SAR (1 g) = 0.477 W/kg

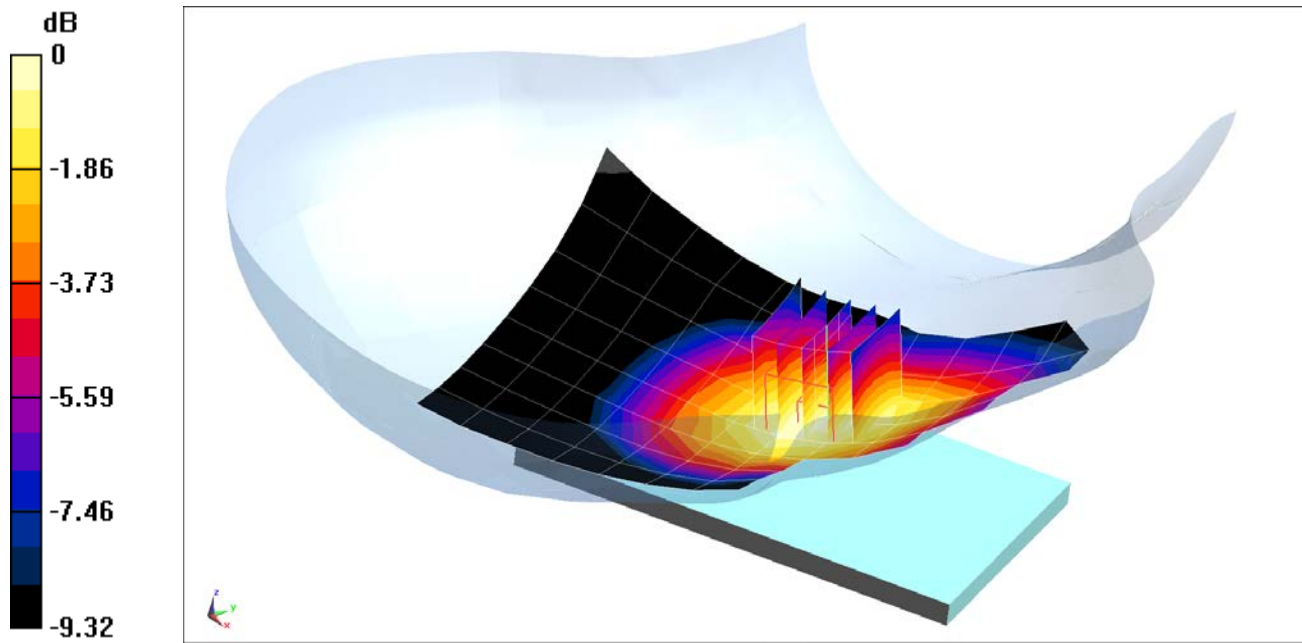

0 dB = 0.522 W/kg = -2.82 dBW/kg

PCTEST ENGINEERING LABORATORY, INC.

DUT: ZNFH636; Type: Portable Handset; Serial: 1TU8L

Communication System: UID 0, UMTS; Frequency: 1732.4 MHz; Duty Cycle: 1:1
Medium: 1750 Head Medium parameters used (interpolated):
 $f = 1732.4 \text{ MHz}$; $\sigma = 1.39 \text{ S/m}$; $\epsilon_r = 38.679$; $\rho = 1000 \text{ kg/m}^3$
Phantom section: Left Section

Test Date: 03-23-2015; Ambient Temp: 23.4°C; Tissue Temp: 20.4°C

Probe: ES3DV3 - SN3334; ConvF(5.21, 5.21, 5.21); Calibrated: 12/16/2014;
Sensor-Surface: 3mm (Mechanical Surface Detection)
Electronics: DAE4 Sn1415; Calibrated: 12/12/2014
Phantom: Sub Twin Sam v5.0; Type: QD000P40CD; Serial: TP:1626
Measurement SW: DASY52, Version 52.8 (8); SEMCAD X Version 14.6.10 (7331)

Mode: AWS UMTS, Left Head, Cheek, Mid.ch

Area Scan (9x15x1): Measurement grid: $dx=15\text{mm}$, $dy=15\text{mm}$

Zoom Scan (5x5x7)/Cube 0: Measurement grid: $dx=8\text{mm}$, $dy=8\text{mm}$, $dz=5\text{mm}$

Reference Value = 21.74 V/m; Power Drift = -0.12 dB

Peak SAR (extrapolated) = 0.953 W/kg

SAR (1 g) = 0.626 W/kg

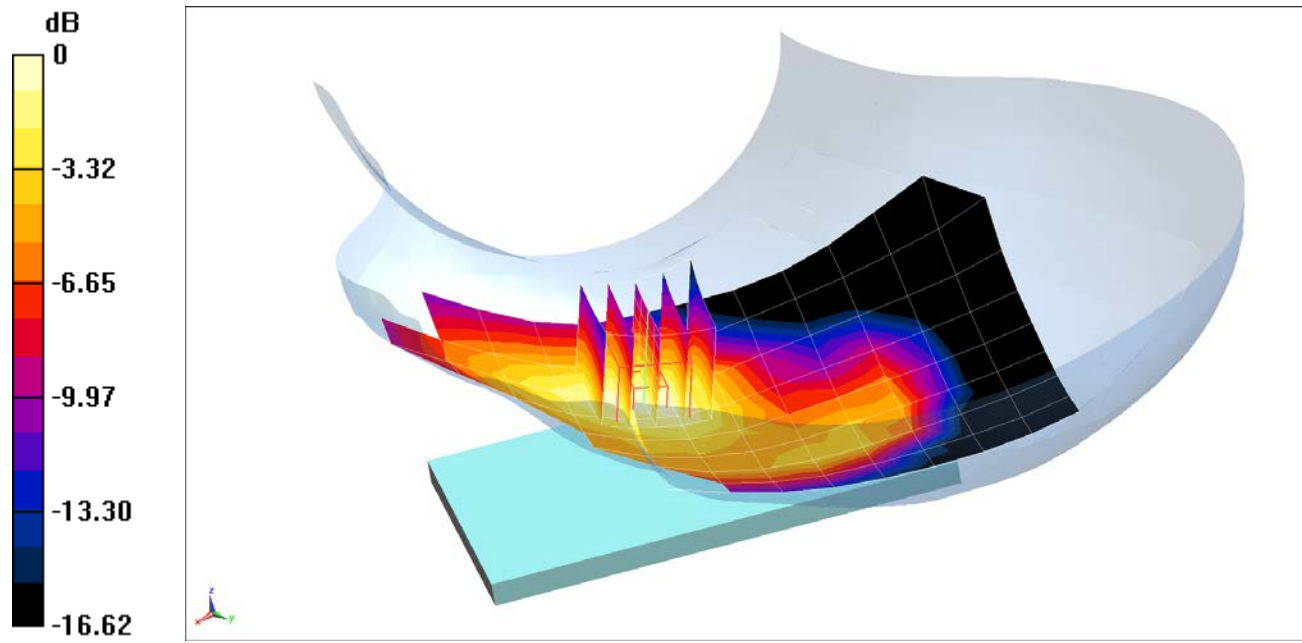

0 dB = 0.746 W/kg = -1.27 dBW/kg

PCTEST ENGINEERING LABORATORY, INC.

DUT: ZNFH636; Type: Portable Handset; Serial: 1TU8L

Communication System: UID 0, UMTS; Frequency: 1880 MHz; Duty Cycle: 1:1
Medium: 1900 Head Medium parameters used:
 $f = 1880 \text{ MHz}$; $\sigma = 1.409 \text{ S/m}$; $\epsilon_r = 40.048$; $\rho = 1000 \text{ kg/m}^3$
Phantom section: Left Section

Test Date: 03-23-2015; Ambient Temp: 22.6°C; Tissue Temp: 21.6°C

Probe: ES3DV3 - SN3213; ConvF(5.06, 5.06, 5.06); Calibrated: 1/20/2015;
Sensor-Surface: 3mm (Mechanical Surface Detection)
Electronics: DAE4 Sn1407; Calibrated: 1/19/2015
Phantom: SAM Front; Type: SAM; Serial: 1686
Measurement SW: DASYS2, Version 52.8 (8); SEMCAD X Version 14.6.10 (7331)

Mode: UMTS 1900, Left Head, Cheek, Mid.ch

Area Scan (9x14x1): Measurement grid: dx=15mm, dy=15mm

Zoom Scan (5x5x7)/Cube 0: Measurement grid: dx=8mm, dy=8mm, dz=5mm

Reference Value = 22.61 V/m; Power Drift = 0.00 dB

Peak SAR (extrapolated) = 1.03 W/kg

SAR (1 g) = 0.663 W/kg

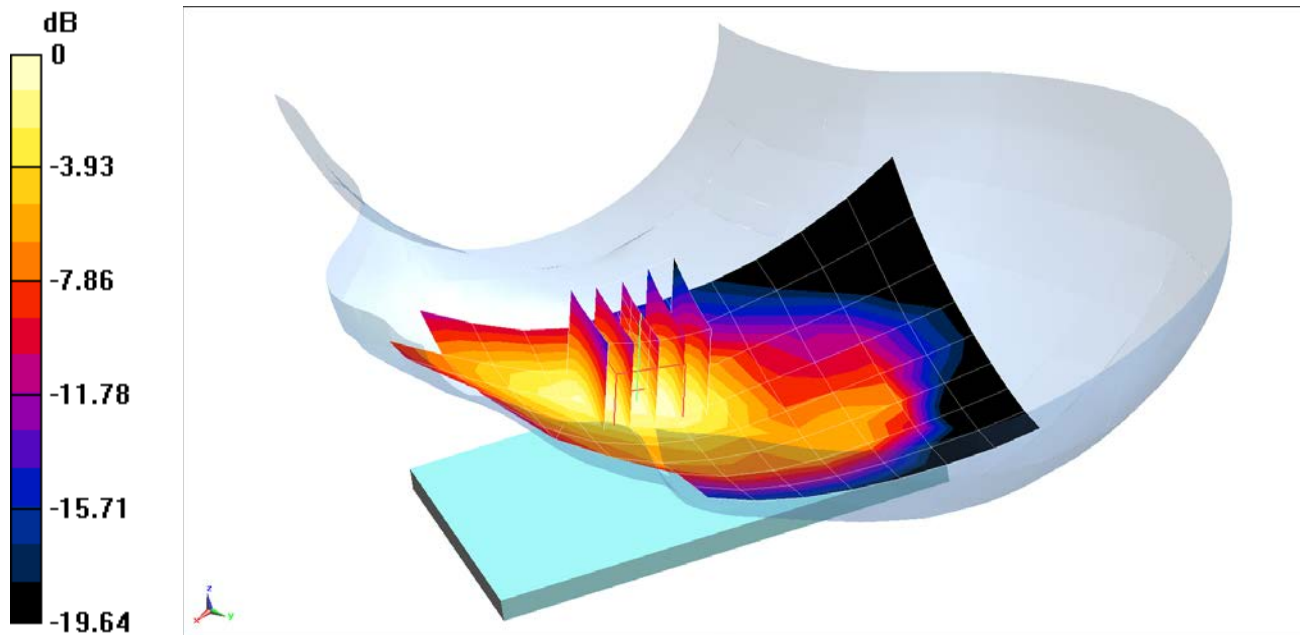

0 dB = 0.788 W/kg = -1.03 dBW/kg

PCTEST ENGINEERING LABORATORY, INC.

DUT: ZNFH636; Type: Portable Handset; Serial: 1TU8K

Communication System: UID 0, LTE Band 12; Frequency: 707.5 MHz; Duty Cycle: 1:1
Medium: 750 Head Medium parameters used (interpolated):
 $f = 707.5 \text{ MHz}$; $\sigma = 0.867 \text{ S/m}$; $\epsilon_r = 41.513$; $\rho = 1000 \text{ kg/m}^3$
Phantom section: Right Section

Test Date: 03-25-2015; Ambient Temp: 22.9°C; Tissue Temp: 21.8°C

Probe: ES3DV2 - SN3022; ConvF(6.39, 6.39, 6.39); Calibrated: 8/19/2014;
Sensor-Surface: 3mm (Mechanical Surface Detection)
Electronics: DAE4 Sn1322; Calibrated: 8/12/2014

Phantom: SAM with CRP v4.0; Type: QD000P40CD; Serial: TP:1800
Measurement SW: DASY52, Version 52.8 (8); SEMCAD X Version 14.6.10 (7331)

Mode: LTE Band 12, Right Head, Cheek, Mid.ch
10 MHz Bandwidth, QPSK, 1 RB, 25 RB Offset

Area Scan (8x13x1): Measurement grid: dx=15mm, dy=15mm

Zoom Scan (5x5x7)/Cube 0: Measurement grid: dx=8mm, dy=8mm, dz=5mm

Reference Value = 22.34 V/m; Power Drift = 0.06 dB

Peak SAR (extrapolated) = 0.456 W/kg

SAR (1 g) = 0.365 W/kg

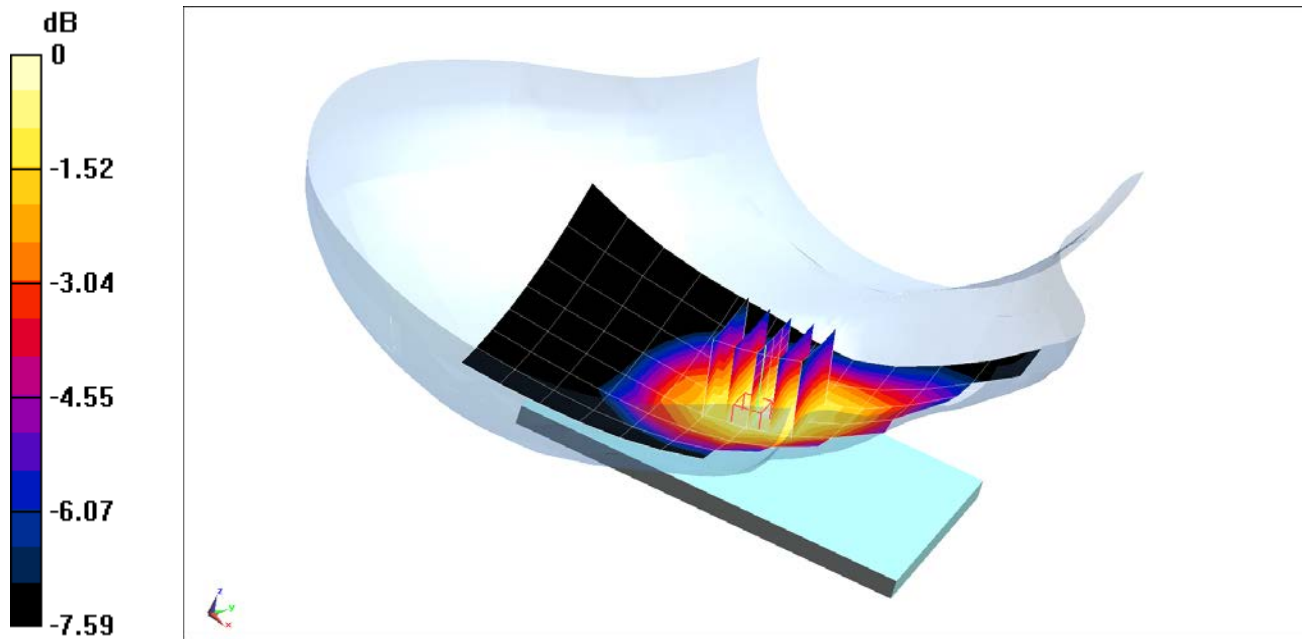

0 dB = 0.422 W/kg = -3.75 dBW/kg

PCTEST ENGINEERING LABORATORY, INC.

DUT: ZNFH636; Type: Portable Handset; Serial: 1TU8K

Communication System: UID 0, LTE Band 5 (Cell.); Frequency: 836.5 MHz; Duty Cycle: 1:1
Medium: 835 Head Medium parameters used (interpolated):
 $f = 836.5 \text{ MHz}$; $\sigma = 0.9 \text{ S/m}$; $\epsilon_r = 40.261$; $\rho = 1000 \text{ kg/m}^3$
Phantom section: Right Section

Test Date: 03-25-2015; Ambient Temp: 22.8°C; Tissue Temp: 22.0°C

Probe: ES3DV3 - SN3288; ConvF(6.51, 6.51, 6.51); Calibrated: 9/24/2014;
Sensor-Surface: 3mm (Mechanical Surface Detection)
Electronics: DAE4 Sn1364; Calibrated: 9/18/2014
Phantom: SAM with CRP v4.0; Type: QD000P40CD; Serial: TP:1797
Measurement SW: DASY52, Version 52.8 (8); SEMCAD X Version 14.6.10 (7331)

Mode: LTE Band 5 (Cell.), Right Head, Cheek, Mid.ch
10 MHz Bandwidth, QPSK, 1 RB, 25 RB Offset

Area Scan (9x15x1): Measurement grid: $dx=15\text{mm}$, $dy=15\text{mm}$
Zoom Scan (5x5x7)/Cube 0: Measurement grid: $dx=8\text{mm}$, $dy=8\text{mm}$, $dz=5\text{mm}$
Reference Value = 22.94 V/m; Power Drift = 0.19 dB
Peak SAR (extrapolated) = 0.549 W/kg
SAR (1 g) = 0.416 W/kg

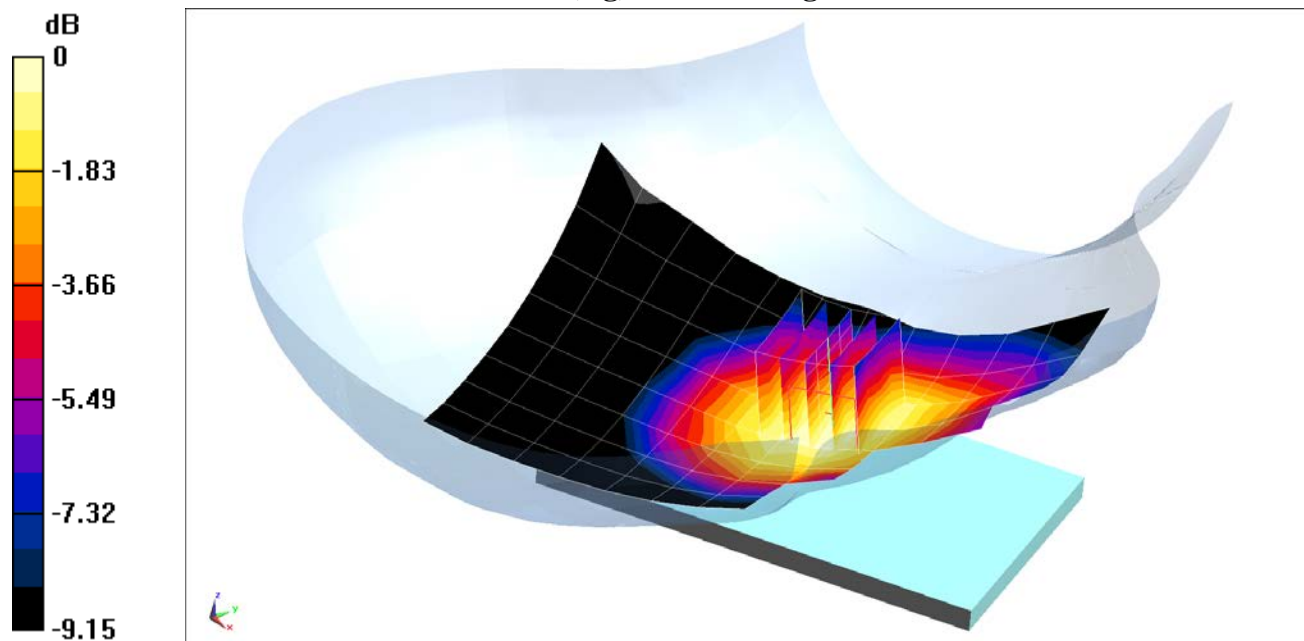

0 dB = 0.457 W/kg = -3.40 dBW/kg

PCTEST ENGINEERING LABORATORY, INC.

DUT: ZNFH636; Type: Portable Handset; Serial: 1TU8K

Communication System: UID 0, LTE RF Band 4; Frequency: 1732.5 MHz; Duty Cycle: 1:1
Medium: 1750 Head Medium parameters used (interpolated):
 $f = 1732.5 \text{ MHz}$; $\sigma = 1.39 \text{ S/m}$; $\epsilon_r = 38.679$; $\rho = 1000 \text{ kg/m}^3$
Phantom section: Left Section

Test Date: 03-23-2015; Ambient Temp: 23.4°C; Tissue Temp: 20.4°C

Probe: ES3DV3 - SN3334; ConvF(5.21, 5.21, 5.21); Calibrated: 12/16/2014;
Sensor-Surface: 3mm (Mechanical Surface Detection)
Electronics: DAE4 Sn1415; Calibrated: 12/12/2014

Phantom: Sub Twin Sam v5.0; Type: QD000P40CD; Serial: TP:1626
Measurement SW: DASY52, Version 52.8 (8); SEMCAD X Version 14.6.10 (7331)

Mode: LTE Band 4 (AWS), Left Head, Cheek, Mid.ch
20 MHz Bandwidth, QPSK, 1 RB, 0 RB Offset

Area Scan (9x15x1): Measurement grid: dx=15mm, dy=15mm

Zoom Scan (5x5x7)/Cube 0: Measurement grid: dx=8mm, dy=8mm, dz=5mm

Reference Value = 21.98 V/m; Power Drift = 0.10 dB

Peak SAR (extrapolated) = 0.827 W/kg

SAR (1 g) = 0.572 W/kg

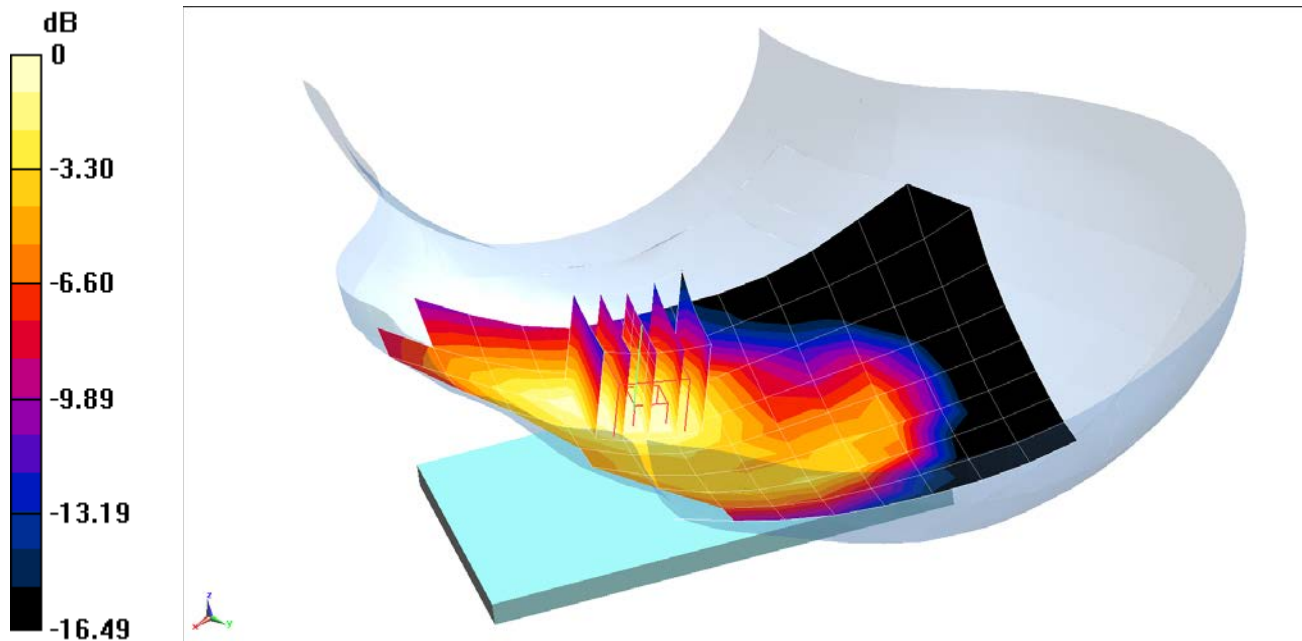

0 dB = 0.655 W/kg = -1.84 dBW/kg

PCTEST ENGINEERING LABORATORY, INC.

DUT: ZNFH636; Type: Portable Handset; Serial: 1TU8K

Communication System: UID 0, LTE Band 2 (PCS); Frequency: 1880 MHz; Duty Cycle: 1:1
Medium: 1900 Head Medium parameters used:
 $f = 1880 \text{ MHz}$; $\sigma = 1.409 \text{ S/m}$; $\epsilon_r = 40.048$; $\rho = 1000 \text{ kg/m}^3$
Phantom section: Left Section

Test Date: 03-23-2015; Ambient Temp: 22.6°C; Tissue Temp: 21.6°C

Probe: ES3DV3 - SN3213; ConvF(5.06, 5.06, 5.06); Calibrated: 1/20/2015;
Sensor-Surface: 3mm (Mechanical Surface Detection)
Electronics: DAE4 Sn1407; Calibrated: 1/19/2015
Phantom: SAM Front; Type: SAM; Serial: 1686
Measurement SW: DASY52, Version 52.8 (8); SEMCAD X Version 14.6.10 (7331)

Mode: LTE Band 2 (PCS), Left Head, Cheek, Mid.ch
20 MHz Bandwidth, QPSK, 1 RB, 99 RB Offset

Area Scan (8x13x1): Measurement grid: dx=15mm, dy=15mm
Zoom Scan (5x5x7)/Cube 0: Measurement grid: dx=8mm, dy=8mm, dz=5mm
Reference Value = 20.85 V/m; Power Drift = 0.12 dB
Peak SAR (extrapolated) = 0.815 W/kg
SAR (1 g) = 0.519 W/kg

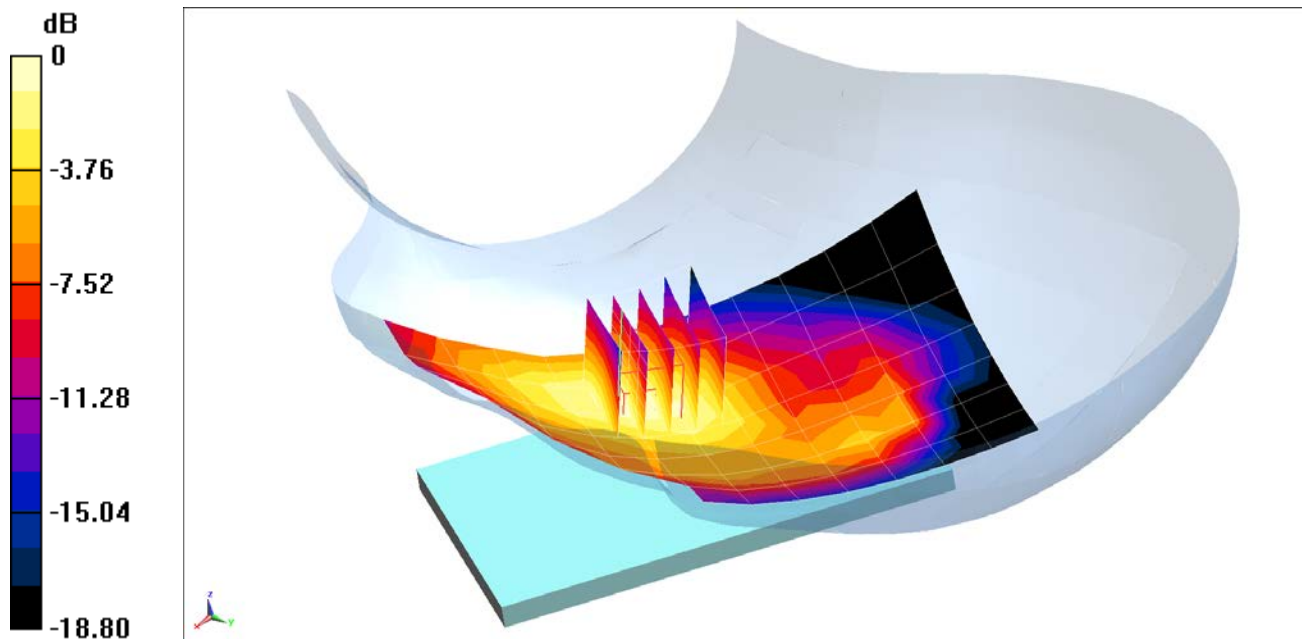

0 dB = 0.591 W/kg = -2.28 dBW/kg

PCTEST ENGINEERING LABORATORY, INC.

DUT: ZNFH636; Type: Portable Handset; Serial: 1TU8K

Communication System: UID 0, LTE Band 7; Frequency: 2510 MHz; Duty Cycle: 1:1
Medium: 2500 Head Medium parameters used (interpolated):
 $f = 2510 \text{ MHz}$; $\sigma = 1.895 \text{ S/m}$; $\epsilon_r = 38.776$; $\rho = 1000 \text{ kg/m}^3$
Phantom section: Right Section

Test Date: 03-23-2015; Ambient Temp: 23.1°C; Tissue Temp: 21.4°C

Probe: ES3DV3 - SN3288; ConvF(4.56, 4.56, 4.56); Calibrated: 9/24/2014;
Sensor-Surface: 3mm (Mechanical Surface Detection)
Electronics: DAE4 Sn1364; Calibrated: 9/18/2014
Phantom: SAM with CRP v4.0; Type: QD000P40CD; Serial: TP:1797
Measurement SW: DASY52, Version 52.8 (8); SEMCAD X Version 14.6.10 (7331)

Mode: LTE Band 7, Right Head, Cheek, Low.ch
20 MHz Bandwidth, QPSK, 1 RB, 50 RB Offset

Area Scan (11x18x1): Measurement grid: dx=12mm, dy=12mm

Zoom Scan (7x7x7)/Cube 0: Measurement grid: dx=5mm, dy=5mm, dz=5mm

Reference Value = 8.278 V/m; Power Drift = 0.13 dB

Peak SAR (extrapolated) = 0.188 W/kg

SAR (1 g) = 0.109 W/kg

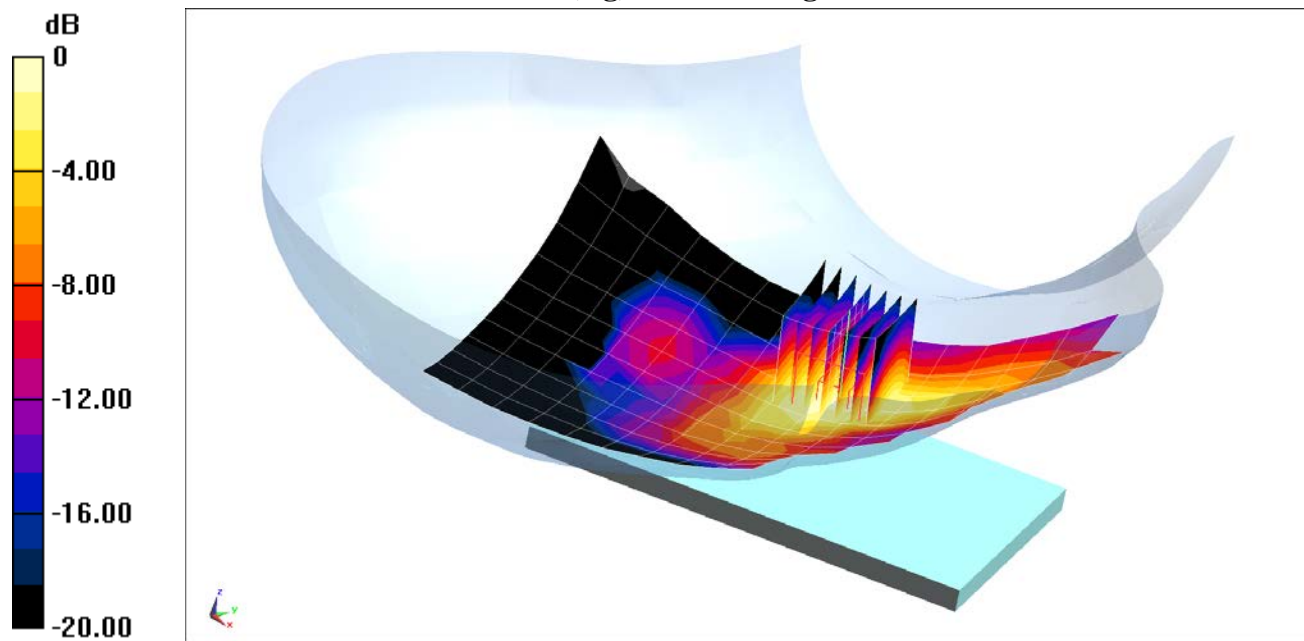

0 dB = 0.134 W/kg = -8.73 dBW/kg

PCTEST ENGINEERING LABORATORY, INC.

DUT: ZNFH636; Type: Portable Handset; Serial: 1TU8Q

Communication System: UID 0, IEEE 802.11b; Frequency: 2437 MHz; Duty Cycle: 1:1
Medium: 2450 Head Medium parameters used (interpolated):
 $f = 2437 \text{ MHz}$; $\sigma = 1.815 \text{ S/m}$; $\epsilon_r = 39.035$; $\rho = 1000 \text{ kg/m}^3$
Phantom section: Left Section

Test Date: 03-23-2015; Ambient Temp: 23.1°C; Tissue Temp: 21.4°C

Probe: ES3DV3 - SN3288; ConvF(4.56, 4.56, 4.56); Calibrated: 9/24/2014;
Sensor-Surface: 3mm (Mechanical Surface Detection)
Electronics: DAE4 Sn1364; Calibrated: 9/18/2014
Phantom: SAM with CRP v4.0; Type: QD000P40CD; Serial: TP:1797
Measurement SW: DASY52, Version 52.8 (8); SEMCAD X Version 14.6.10 (7331)

Mode: IEEE 802.11b, Left Head, Cheek, Ch 06, 1 Mbps, 22 MHz Bandwidth

Area Scan (11x18x1): Measurement grid: $dx=12\text{mm}$, $dy=12\text{mm}$
Zoom Scan (7x7x7)/Cube 0: Measurement grid: $dx=5\text{mm}$, $dy=5\text{mm}$, $dz=5\text{mm}$
Reference Value = 10.86 V/m; Power Drift = 0.04 dB
Peak SAR (extrapolated) = 0.552 W/kg
SAR (1 g) = 0.240 W/kg

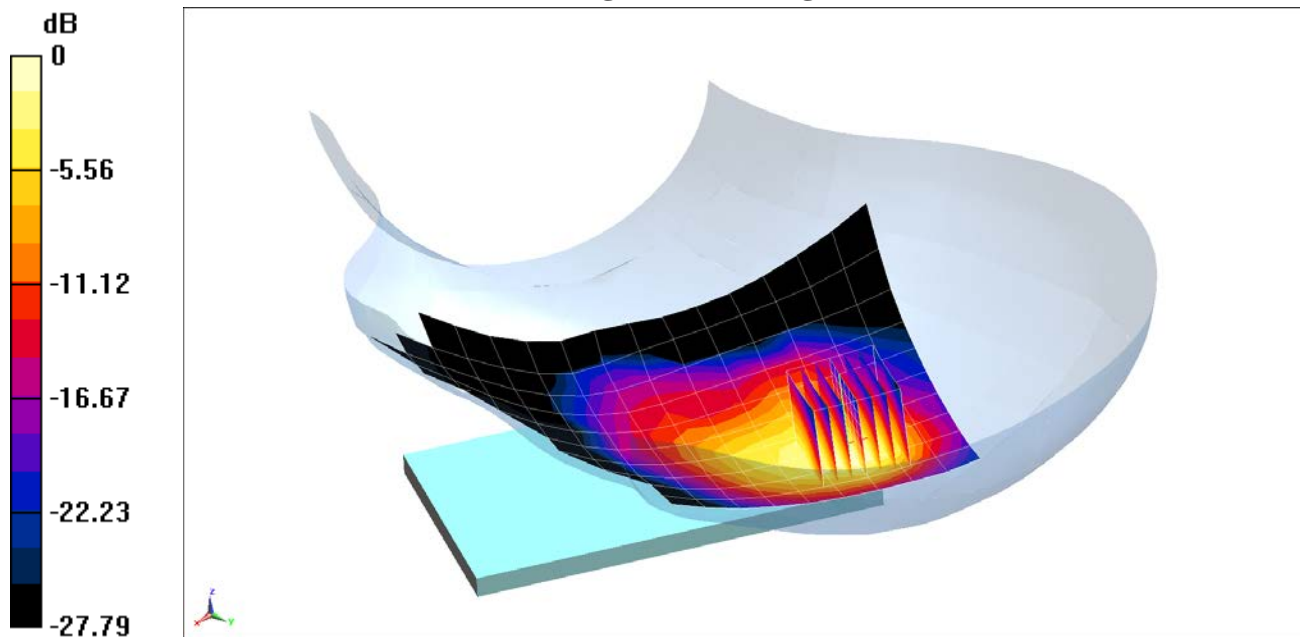

0 dB = 0.307 W/kg = -5.13 dBW/kg

PCTEST ENGINEERING LABORATORY, INC.

DUT: ZNFH636; Type: Portable Handset; Serial: 1TU8Q

Communication System: UID 0, IEEE 802.11n; Frequency: 5795 MHz; Duty Cycle: 1:1
Medium: 5GHz Head Medium parameters used (interpolated):
 $f = 5795 \text{ MHz}$; $\sigma = 5.195 \text{ S/m}$; $\epsilon_r = 35.957$; $\rho = 1000 \text{ kg/m}^3$
Phantom section: Left Section

Test Date: 03-26-2015; Ambient Temp: 22.7°C; Tissue Temp: 21.1°C

Probe: EX3DV4 - SN3920; ConvF(4.27, 4.27, 4.27); Calibrated: 12/12/2014;
Sensor-Surface: 1.4mm (Mechanical Surface Detection)
Electronics: DAE4 Sn665; Calibrated: 2/18/2015
Phantom: SAM, Left; Type: QD000P40CD; Serial: TP:1759
Measurement SW: DASY52, Version 52.8 (8); SEMCAD X Version 14.6.10 (7331)

Mode: IEEE 802.11n, 5.8 GHz, Left Head, Cheek, Ch 159, 13.5 Mbps, 40 MHz Bandwidth

Area Scan (13x20x1): Measurement grid: dx=10mm, dy=10mm

Zoom Scan (7x7x7)/Cube 0: Measurement grid: dx=4mm, dy=4mm, dz=1.4mm; Graded Ratio = 1.4
Reference Value = 7.604 V/m; Power Drift = 0.10 dB
Peak SAR (extrapolated) = 1.30 W/kg
SAR (1 g) = 0.260 W/kg

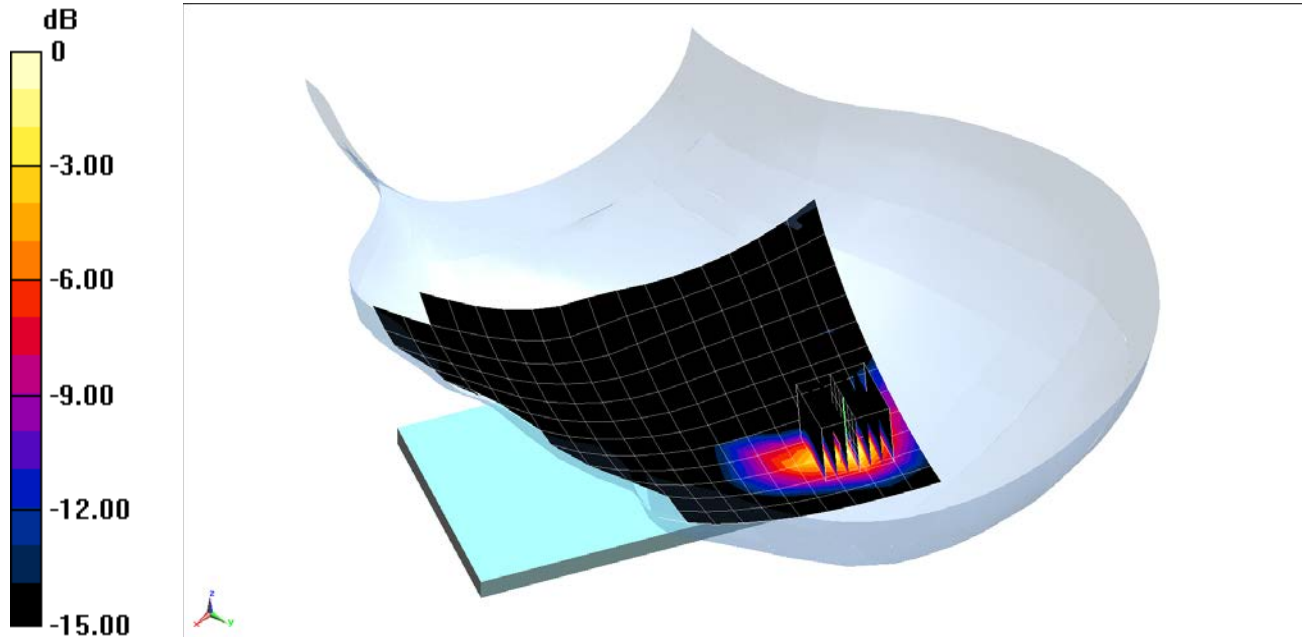

0 dB = 0.679 W/kg = -1.68 dBW/kg

PCTEST ENGINEERING LABORATORY, INC.

DUT: ZNFH636; Type: Portable Handset; Serial: 1TU8L

Communication System: UID 0, GSM; Frequency: 836.6 MHz; Duty Cycle: 1:8.3
Medium: 835 Body Medium parameters used (interpolated):
 $f = 836.6 \text{ MHz}$; $\sigma = 0.963 \text{ S/m}$; $\epsilon_r = 52.919$; $\rho = 1000 \text{ kg/m}^3$
Phantom section: Flat Section; Space: 1.0 cm

Test Date: 03-19-2015; Ambient Temp: 24.4°C; Tissue Temp: 22.0°C

Probe: ES3DV3 - SN3333; ConvF(6.12, 6.12, 6.12); Calibrated: 10/24/2014;
Sensor-Surface: 3mm (Mechanical Surface Detection)
Electronics: DAE4 Sn1408; Calibrated: 10/23/2014
Phantom: Sub TWIN SAM; Type: QD000P40CC; Serial: TP-1357
Measurement SW: DASYS2, Version 52.8 (8); SEMCAD X Version 14.6.10 (7331)

Mode: GSM 850, Body SAR, Back side, Mid.ch

Area Scan (9x15x1): Measurement grid: $dx=15\text{mm}$, $dy=15\text{mm}$

Zoom Scan (5x5x7)/Cube 0: Measurement grid: $dx=8\text{mm}$, $dy=8\text{mm}$, $dz=5\text{mm}$

Reference Value = 21.24 V/m; Power Drift = 0.04 dB

Peak SAR (extrapolated) = 0.725 W/kg

SAR (1 g) = 0.413 W/kg

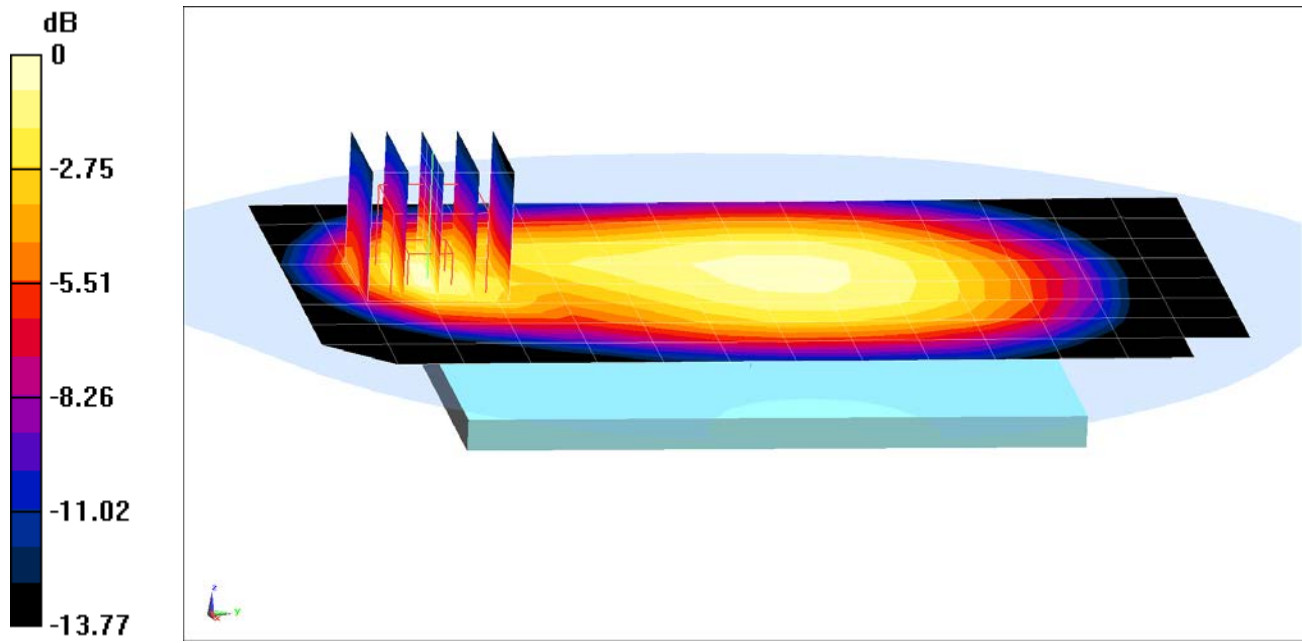

0 dB = 0.518 W/kg = -2.86 dBW/kg

PCTEST ENGINEERING LABORATORY, INC.

DUT: ZNFH636; Type: Portable Handset; Serial: 1TU8L

Communication System: UID 0, GSM GPRS 1 Tx slot; Frequency: 836.6 MHz; Duty Cycle: 1:8.3
Medium: 835 Body Medium parameters used (interpolated):
 $f = 836.6 \text{ MHz}$; $\sigma = 0.963 \text{ S/m}$; $\epsilon_r = 52.919$; $\rho = 1000 \text{ kg/m}^3$
Phantom section: Flat Section; Space: 1.0 cm

Test Date: 03-19-2015; Ambient Temp: 24.4°C; Tissue Temp: 22.0°C

Probe: ES3DV3 - SN3333; ConvF(6.12, 6.12, 6.12); Calibrated: 10/24/2014;
Sensor-Surface: 3mm (Mechanical Surface Detection)
Electronics: DAE4 Sn1408; Calibrated: 10/23/2014
Phantom: Sub TWIN SAM; Type: QD000P40CC; Serial: TP-1357
Measurement SW: DASY52, Version 52.8 (8); SEMCAD X Version 14.6.10 (7331)

Mode: GPRS 850, Body SAR, Right Edge, Mid.ch, 1 Tx Slot

Area Scan (10x13x1): Measurement grid: $dx=5\text{mm}$, $dy=15\text{mm}$
Zoom Scan (5x5x7)/Cube 0: Measurement grid: $dx=8\text{mm}$, $dy=8\text{mm}$, $dz=5\text{mm}$
Reference Value = 24.40 V/m; Power Drift = -0.01 dB
Peak SAR (extrapolated) = 0.733 W/kg
SAR (1 g) = 0.532 W/kg

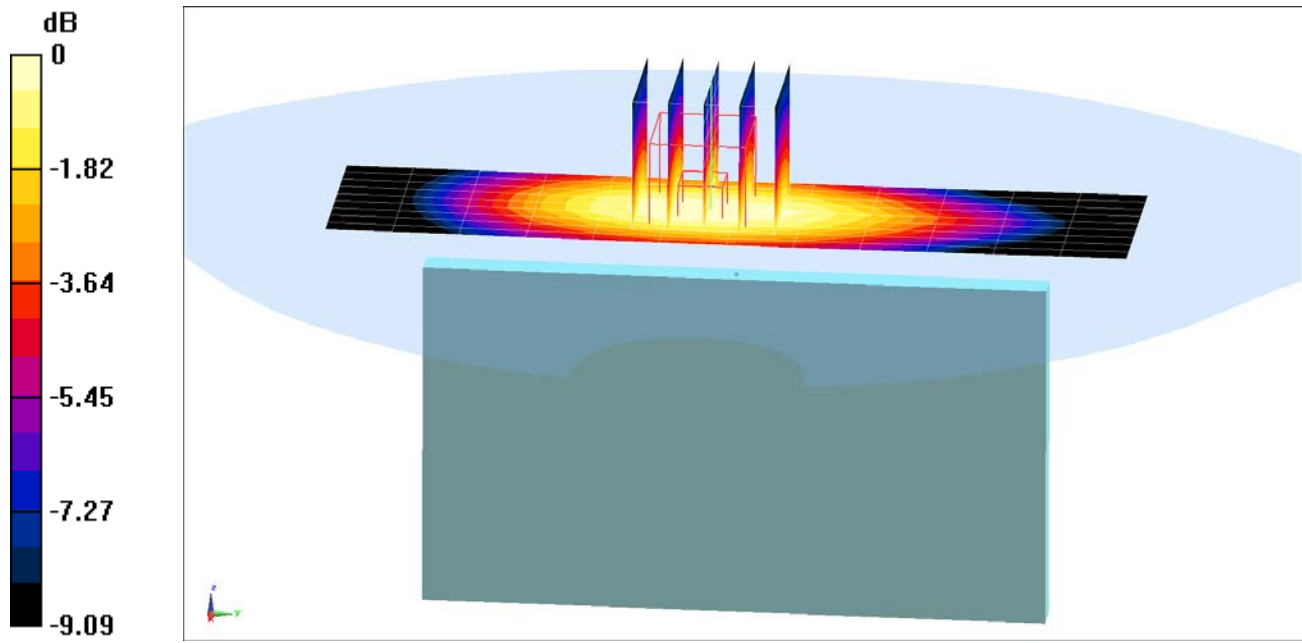

0 dB = 0.606 W/kg = -2.18 dBW/kg

PCTEST ENGINEERING LABORATORY, INC.

DUT: ZNFH636; Type: Portable Handset; Serial: 1TU8L

Communication System: UID 0, GSM GPRS 3 Tx slots; Frequency: 1880 MHz; Duty Cycle: 1:2.76
Medium: 1900 Body Medium parameters used:
 $f = 1880 \text{ MHz}$; $\sigma = 1.537 \text{ S/m}$; $\epsilon_r = 51.957$; $\rho = 1000 \text{ kg/m}^3$
Phantom section: Flat Section; Space: 1.0 cm

Test Date: 03-23-2015; Ambient Temp: 23.3°C; Tissue Temp: 21.7°C

Probe: ES3DV2 - SN3022; ConvF(4.49, 4.49, 4.49); Calibrated: 8/19/2014;
Sensor-Surface: 3mm (Mechanical Surface Detection)
Electronics: DAE4 Sn1322; Calibrated: 8/12/2014
Phantom: ELI v5.0; Type: QDOVA001BB; Serial: 1226
Measurement SW: DASYS2, Version 52.8 (8); SEMCAD X Version 14.6.10 (7331)

Mode: GPRS 1900, Body SAR, Back side, Mid.ch, 3 Tx Slots

Area Scan (8x14x1): Measurement grid: dx=15mm, dy=15mm
Zoom Scan (5x5x7)/Cube 0: Measurement grid: dx=8mm, dy=8mm, dz=5mm
Reference Value = 16.42 V/m; Power Drift = -0.03 dB
Peak SAR (extrapolated) = 0.653 W/kg
SAR (1 g) = 0.382 W/kg

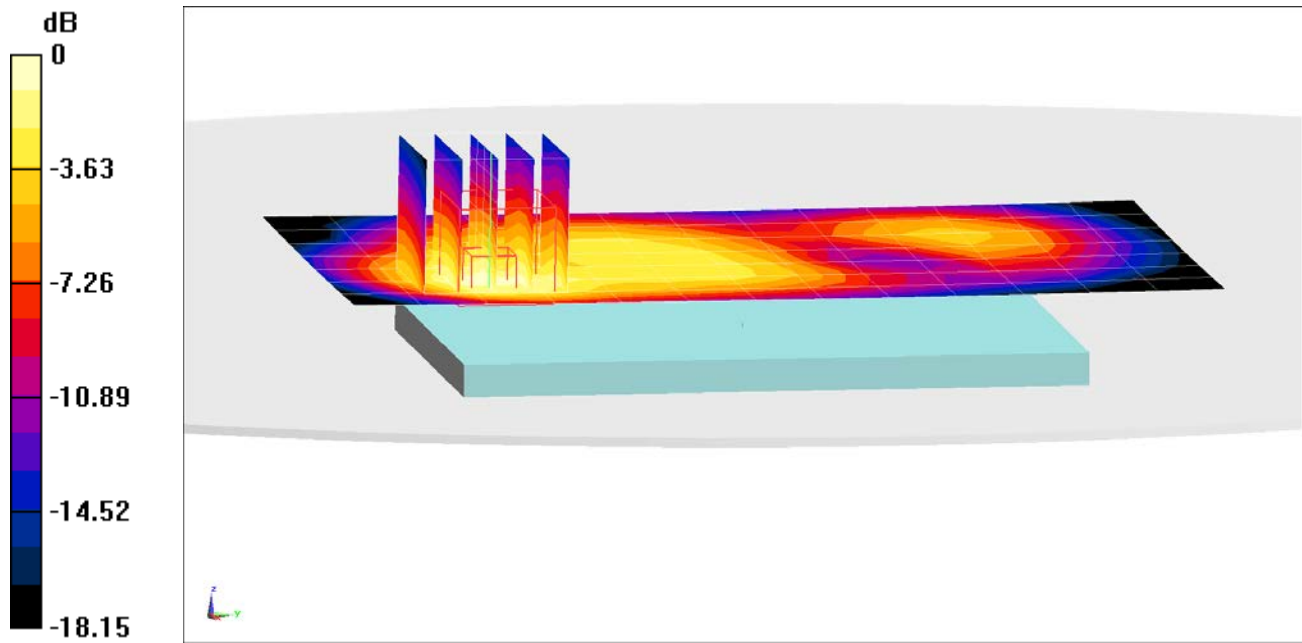

0 dB = 0.446 W/kg = -3.51 dBW/kg

PCTEST ENGINEERING LABORATORY, INC.

DUT: ZNFH636; Type: Portable Handset; Serial: 1TU8L

Communication System: UID 0, UMTS; Frequency: 836.6 MHz; Duty Cycle: 1:1
Medium: 835 Body Medium parameters used (interpolated):
 $f = 836.6 \text{ MHz}$; $\sigma = 0.963 \text{ S/m}$; $\epsilon_r = 52.919$; $\rho = 1000 \text{ kg/m}^3$
Phantom section: Flat Section; Space: 1.0 cm

Test Date: 03-19-2015; Ambient Temp: 24.4°C; Tissue Temp: 22.0°C

Probe: ES3DV3 - SN3333; ConvF(6.12, 6.12, 6.12); Calibrated: 10/24/2014;
Sensor-Surface: 3mm (Mechanical Surface Detection)
Electronics: DAE4 Sn1408; Calibrated: 10/23/2014
Phantom: Sub TWIN SAM; Type: QD000P40CC; Serial: TP-1357
Measurement SW: DASYS2, Version 52.8 (8); SEMCAD X Version 14.6.10 (7331)

Mode: UMTS 850, Body SAR, Back side, Mid.ch

Area Scan (9x15x1): Measurement grid: $dx=15\text{mm}$, $dy=15\text{mm}$

Zoom Scan (5x5x7)/Cube 0: Measurement grid: $dx=8\text{mm}$, $dy=8\text{mm}$, $dz=5\text{mm}$

Reference Value = 26.16 V/m; Power Drift = 0.05 dB

Peak SAR (extrapolated) = 1.15 W/kg

SAR (1 g) = 0.645 W/kg

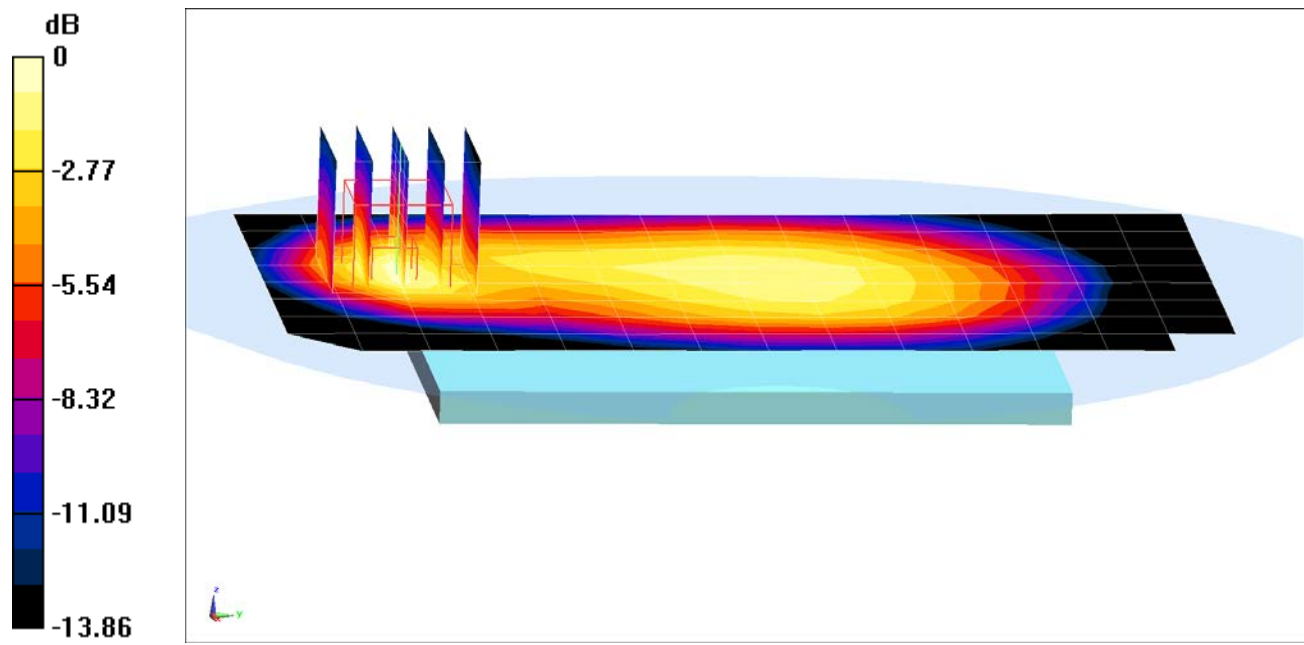

0 dB = 0.808 W/kg = -0.93 dBW/kg

PCTEST ENGINEERING LABORATORY, INC.

DUT: ZNFH636; Type: Portable Handset; Serial: 1TU8L

Communication System: UID 0, UMTS; Frequency: 836.6 MHz; Duty Cycle: 1:1
Medium: 835 Body Medium parameters used (interpolated):
 $f = 836.6 \text{ MHz}$; $\sigma = 0.963 \text{ S/m}$; $\epsilon_r = 52.919$; $\rho = 1000 \text{ kg/m}^3$
Phantom section: Flat Section; Space: 1.0 cm

Test Date: 03-19-2015; Ambient Temp: 24.4°C; Tissue Temp: 22.0°C

Probe: ES3DV3 - SN3333; ConvF(6.12, 6.12, 6.12); Calibrated: 10/24/2014;
Sensor-Surface: 3mm (Mechanical Surface Detection)
Electronics: DAE4 Sn1408; Calibrated: 10/23/2014
Phantom: Sub TWIN SAM; Type: QD000P40CC; Serial: TP-1357
Measurement SW: DASY52, Version 52.8 (8); SEMCAD X Version 14.6.10 (7331)

Mode: UMTS 850, Body SAR, Right Edge, Mid.ch

Area Scan (10x13x1): Measurement grid: dx=5mm, dy=15mm

Zoom Scan (5x5x7)/Cube 0: Measurement grid: dx=8mm, dy=8mm, dz=5mm

Reference Value = 28.93 V/m; Power Drift = 0.01 dB

Peak SAR (extrapolated) = 1.07 W/kg

SAR (1 g) = 0.764 W/kg

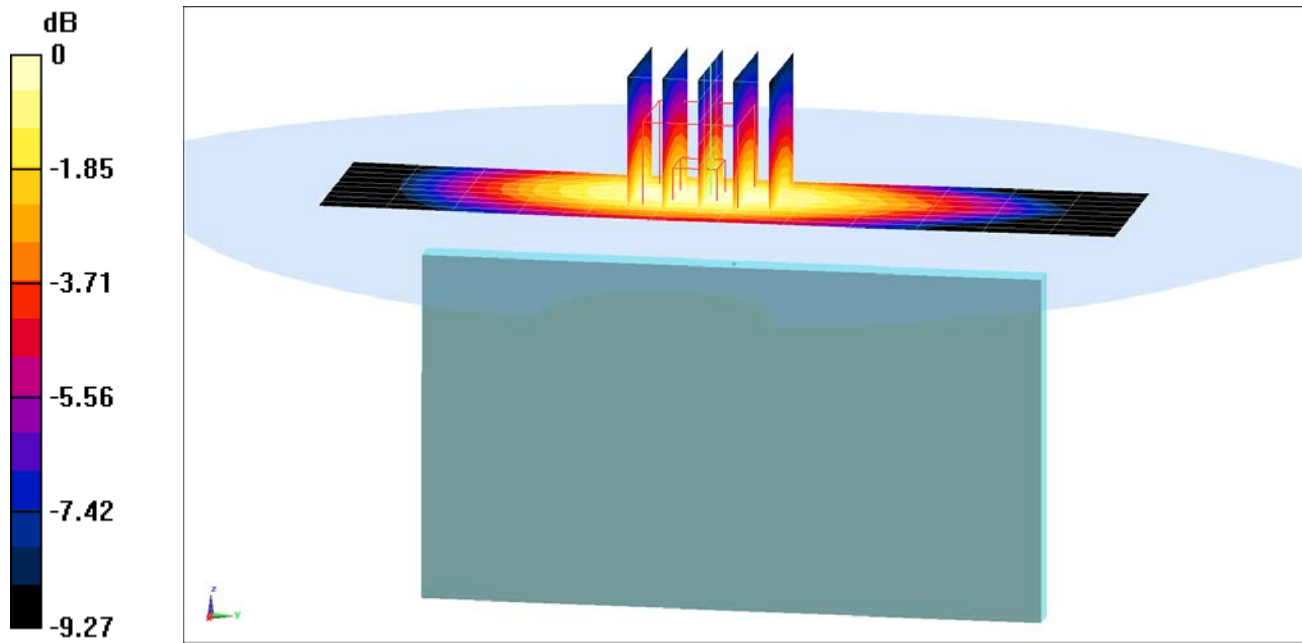

0 dB = 0.872 W/kg = -0.59 dBW/kg

PCTEST ENGINEERING LABORATORY, INC.

DUT: ZNFH636; Type: Portable Handset; Serial: 1TU8L

Communication System: UID 0, UMTS; Frequency: 1732.4 MHz; Duty Cycle: 1:1
Medium: 1750 Body Medium parameters used (interpolated):
 $f = 1732.4 \text{ MHz}$; $\sigma = 1.497 \text{ S/m}$; $\epsilon_r = 52.947$; $\rho = 1000 \text{ kg/m}^3$
Phantom section: Flat Section; Space: 1.0 cm

Test Date: 03-25-2015; Ambient Temp: 23.3°C; Tissue Temp: 21.4°C

Probe: ES3DV3 - SN3334; ConvF(4.94, 4.94, 4.94); Calibrated: 12/16/2014;
Sensor-Surface: 3mm (Mechanical Surface Detection)
Electronics: DAE4 Sn1415; Calibrated: 12/12/2014
Phantom: ELI v5.0; Type: QDOVA001BB; Serial: 1158
Measurement SW: DASY52, Version 52.8 (8); SEMCAD X Version 14.6.10 (7331)

Mode: AWS UMTS, Body SAR, Back side, Mid.ch

Area Scan (9x13x1): Measurement grid: $dx=15\text{mm}$, $dy=15\text{mm}$

Zoom Scan (6x6x7)/Cube 0: Measurement grid: $dx=8\text{mm}$, $dy=8\text{mm}$, $dz=5\text{mm}$

Reference Value = 22.67 V/m; Power Drift = 0.06 dB

Peak SAR (extrapolated) = 1.04 W/kg

SAR (1 g) = 0.720 W/kg

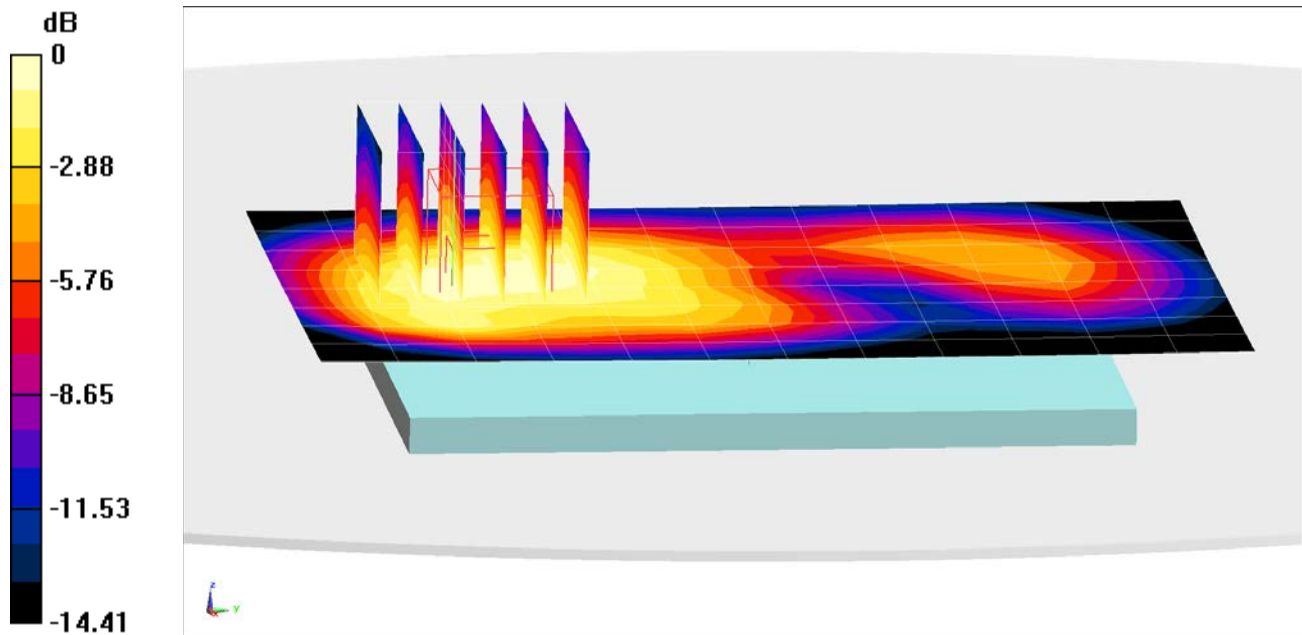

0 dB = 0.823 W/kg = -0.85 dBW/kg

PCTEST ENGINEERING LABORATORY, INC.

DUT: ZNFH636; Type: Portable Handset; Serial: 1TU8L

Communication System: UID 0, UMTS; Frequency: 1732.4 MHz; Duty Cycle: 1:1
Medium: 1750 Body Medium parameters used (interpolated):
 $f = 1732.4 \text{ MHz}$; $\sigma = 1.497 \text{ S/m}$; $\epsilon_r = 52.947$; $\rho = 1000 \text{ kg/m}^3$
Phantom section: Flat Section; Space: 1.0 cm

Test Date: 03-25-2015; Ambient Temp: 23.3°C; Tissue Temp: 21.4°C

Probe: ES3DV3 - SN3334; ConvF(4.94, 4.94, 4.94); Calibrated: 12/16/2014;
Sensor-Surface: 3mm (Mechanical Surface Detection)
Electronics: DAE4 Sn1415; Calibrated: 12/12/2014
Phantom: ELI v5.0; Type: QDOVA001BB; Serial: 1158
Measurement SW: DASYS2, Version 52.8 (8); SEMCAD X Version 14.6.10 (7331)

Mode: AWS UMTS, Body SAR, Front side, Mid.ch

Area Scan (9x13x1): Measurement grid: dx=15mm, dy=15mm

Zoom Scan (5x5x7)/Cube 0: Measurement grid: dx=8mm, dy=8mm, dz=5mm

Reference Value = 24.50 V/m; Power Drift = 0.04 dB

Peak SAR (extrapolated) = 1.37 W/kg

SAR (1 g) = 0.792 W/kg

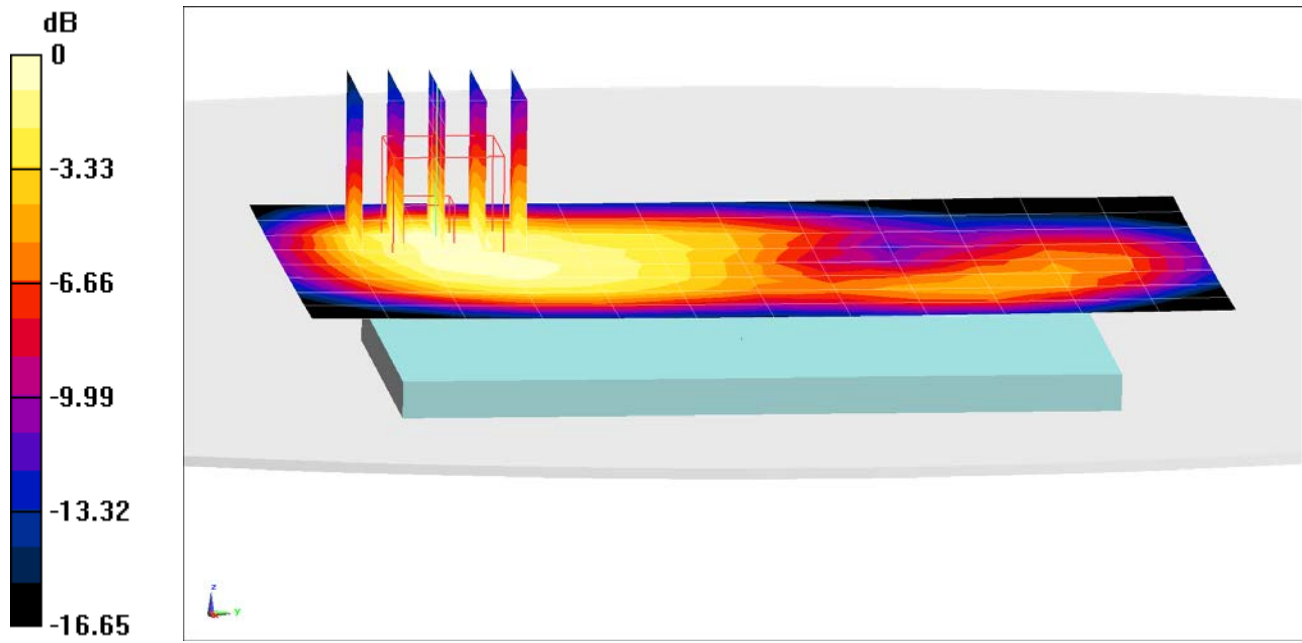

0 dB = 0.946 W/kg = -0.24 dBW/kg

PCTEST ENGINEERING LABORATORY, INC.

DUT: ZNFH636; Type: Portable Handset; Serial: 1TU8L

Communication System: UID 0, UMTS; Frequency: 1880 MHz; Duty Cycle: 1:1
Medium: 1900 Body Medium parameters used:
 $f = 1880 \text{ MHz}$; $\sigma = 1.537 \text{ S/m}$; $\epsilon_r = 51.957$; $\rho = 1000 \text{ kg/m}^3$
Phantom section: Flat Section; Space: 1.0 cm

Test Date: 03-23-2015; Ambient Temp: 23.3°C; Tissue Temp: 21.7°C

Probe: ES3DV2 - SN3022; ConvF(4.49, 4.49, 4.49); Calibrated: 8/19/2014;
Sensor-Surface: 3mm (Mechanical Surface Detection)
Electronics: DAE4 Sn1322; Calibrated: 8/12/2014
Phantom: ELI v5.0; Type: QDOVA001BB; Serial: 1226
Measurement SW: DASY52, Version 52.8 (8); SEMCAD X Version 14.6.10 (7331)

Mode: UMTS 1900, Body SAR, Back side, Mid.ch

Area Scan (9x15x1): Measurement grid: dx=15mm, dy=15mm

Zoom Scan (5x5x7)/Cube 0: Measurement grid: dx=8mm, dy=8mm, dz=5mm

Reference Value = 23.48 V/m; Power Drift = 0.00 dB

Peak SAR (extrapolated) = 1.34 W/kg

SAR (1 g) = 0.783 W/kg

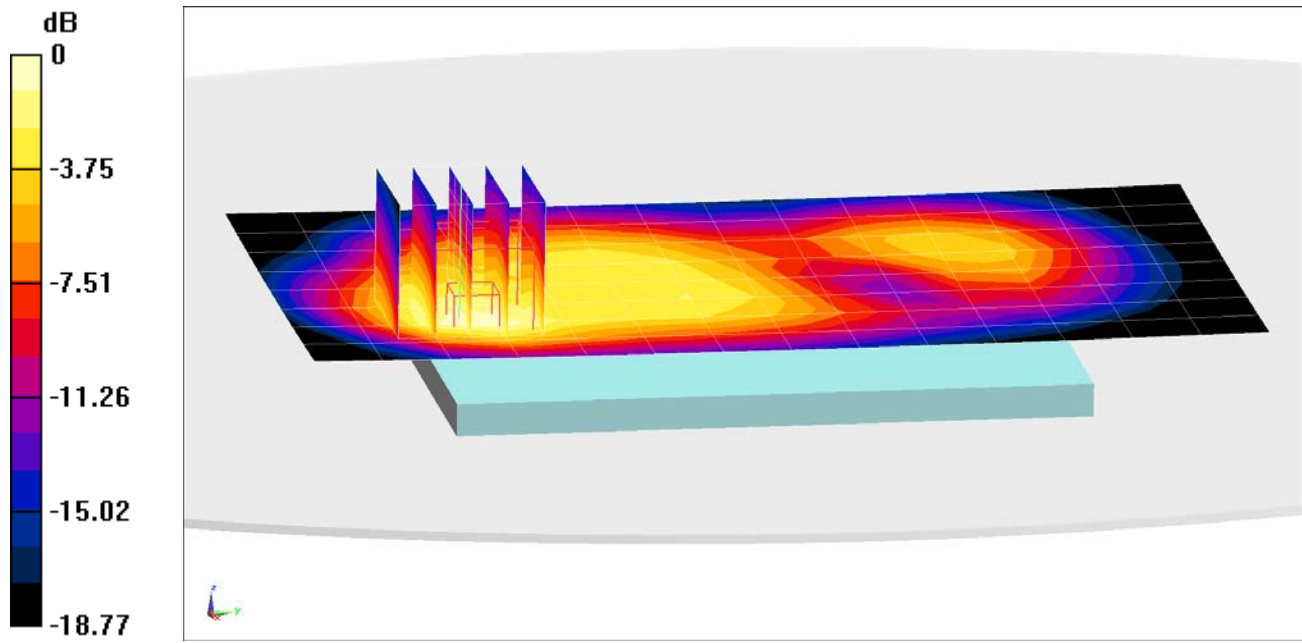

0 dB = 0.948 W/kg = -0.23 dBW/kg

PCTEST ENGINEERING LABORATORY, INC.

DUT: ZNFH636; Type: Portable Handset; Serial: 1TU8K

Communication System: UID 0, LTE Band 12; Frequency: 707.5 MHz; Duty Cycle: 1:1
Medium: 750 Body Medium parameters used (interpolated):
 $f = 707.5 \text{ MHz}$; $\sigma = 0.934 \text{ S/m}$; $\epsilon_r = 55.349$; $\rho = 1000 \text{ kg/m}^3$
Phantom section: Flat Section; Space: 1.0 cm

Test Date: 03-24-2015; Ambient Temp: 23.0°C; Tissue Temp: 22.1°C

Probe: ES3DV3 - SN3263; ConvF(6.19, 6.19, 6.19); Calibrated: 5/15/2014;
Sensor-Surface: 3mm (Mechanical Surface Detection)
Electronics: DAE4 Sn859; Calibrated: 5/14/2014

Phantom: SAM v5.0 Left; Type: QD000P40CD; Serial: TP: 1687
Measurement SW: DASY52, Version 52.8 (8); SEMCAD X Version 14.6.10 (7331)

Mode: LTE Band 12, Body SAR, Back side, Mid.ch
10 MHz Bandwidth, QPSK, 1 RB, 25 RB Offset

Area Scan (9x13x1): Measurement grid: dx=15mm, dy=15mm

Zoom Scan (5x6x7)/Cube 0: Measurement grid: dx=8mm, dy=8mm, dz=5mm

Reference Value = 28.31 V/m; Power Drift = 0.15 dB

Peak SAR (extrapolated) = 0.945 W/kg

SAR (1 g) = 0.734 W/kg

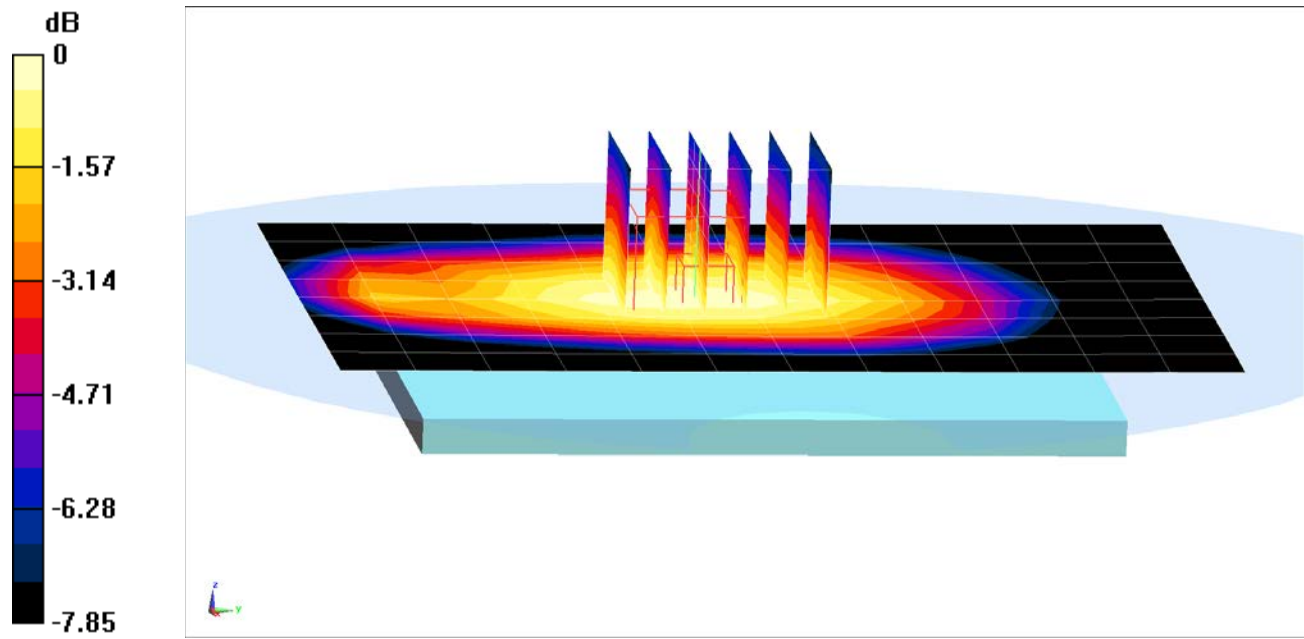

0 dB = 0.808 W/kg = -0.93 dBW/kg

PCTEST ENGINEERING LABORATORY, INC.

DUT: ZNFH636; Type: Portable Handset; Serial: 1TU8K

Communication System: UID 0, LTE Band 5; Frequency: 836.5 MHz; Duty Cycle: 1:1
Medium: 835 Body Medium parameters used (interpolated):
 $f = 836.5 \text{ MHz}$; $\sigma = 0.938 \text{ S/m}$; $\epsilon_r = 53.003$; $\rho = 1000 \text{ kg/m}^3$
Phantom section: Flat Section; Space: 1.0 cm

Test Date: 03-23-2015; Ambient Temp: 24.5°C; Tissue Temp: 21.4°C

Probe: ES3DV3 - SN3333; ConvF(6.12, 6.12, 6.12); Calibrated: 10/24/2014;
Sensor-Surface: 3mm (Mechanical Surface Detection)
Electronics: DAE4 Sn1408; Calibrated: 10/23/2014
Phantom: Sub TWIN SAM; Type: QD000P40CC; Serial: TP-1357
Measurement SW: DASY52, Version 52.8 (8); SEMCAD X Version 14.6.10 (7331)

Mode: LTE Band 5 (Cell.), Body SAR, Back side, Mid.ch
10 MHz Bandwidth, QPSK, 1 RB, 25 RB Offset

Area Scan (9x15x1): Measurement grid: dx=15mm, dy=15mm

Zoom Scan (6x6x7)/Cube 0: Measurement grid: dx=8mm, dy=8mm, dz=5mm

Reference Value = 24.82 V/m; Power Drift = 0.17 dB

Peak SAR (extrapolated) = 0.763 W/kg

SAR (1 g) = 0.568 W/kg

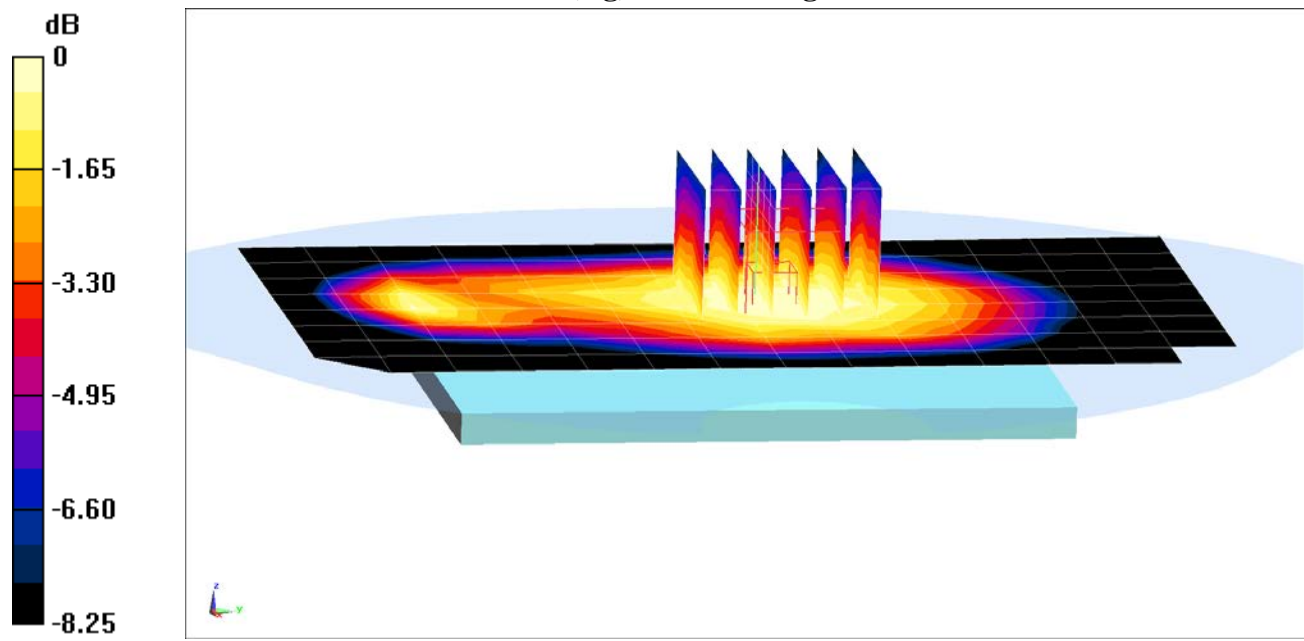

0 dB = 0.630 W/kg = -2.01 dBW/kg

PCTEST ENGINEERING LABORATORY, INC.

DUT: ZNFH636; Type: Portable Handset; Serial: 1TU8K

Communication System: UID 0, LTE Band 5 (Cell.); Frequency: 836.5 MHz; Duty Cycle: 1:1
Medium: 835 Body Medium parameters used (interpolated):
 $f = 836.5 \text{ MHz}$; $\sigma = 0.938 \text{ S/m}$; $\epsilon_r = 53.003$; $\rho = 1000 \text{ kg/m}^3$
Phantom section: Flat Section; Space: 1.0 cm

Test Date: 03-23-2015; Ambient Temp: 24.5°C; Tissue Temp: 21.4°C

Probe: ES3DV3 - SN3333; ConvF(6.12, 6.12, 6.12); Calibrated: 10/24/2014;
Sensor-Surface: 3mm (Mechanical Surface Detection)
Electronics: DAE4 Sn1408; Calibrated: 10/23/2014
Phantom: Sub TWIN SAM; Type: QD000P40CC; Serial: TP-1357
Measurement SW: DASY52, Version 52.8 (8); SEMCAD X Version 14.6.10 (7331)

Mode: LTE Band 5 (Cell.), Body SAR, Right Edge, Mid.ch
10 MHz Bandwidth, QPSK, 1 RB, 25 RB Offset

Area Scan (11x13x1): Measurement grid: $dx=5\text{mm}$, $dy=15\text{mm}$

Zoom Scan (5x5x7)/Cube 0: Measurement grid: $dx=8\text{mm}$, $dy=8\text{mm}$, $dz=5\text{mm}$

Reference Value = 28.08 V/m; Power Drift = 0.13 dB

Peak SAR (extrapolated) = 0.938 W/kg

SAR (1 g) = 0.694 W/kg

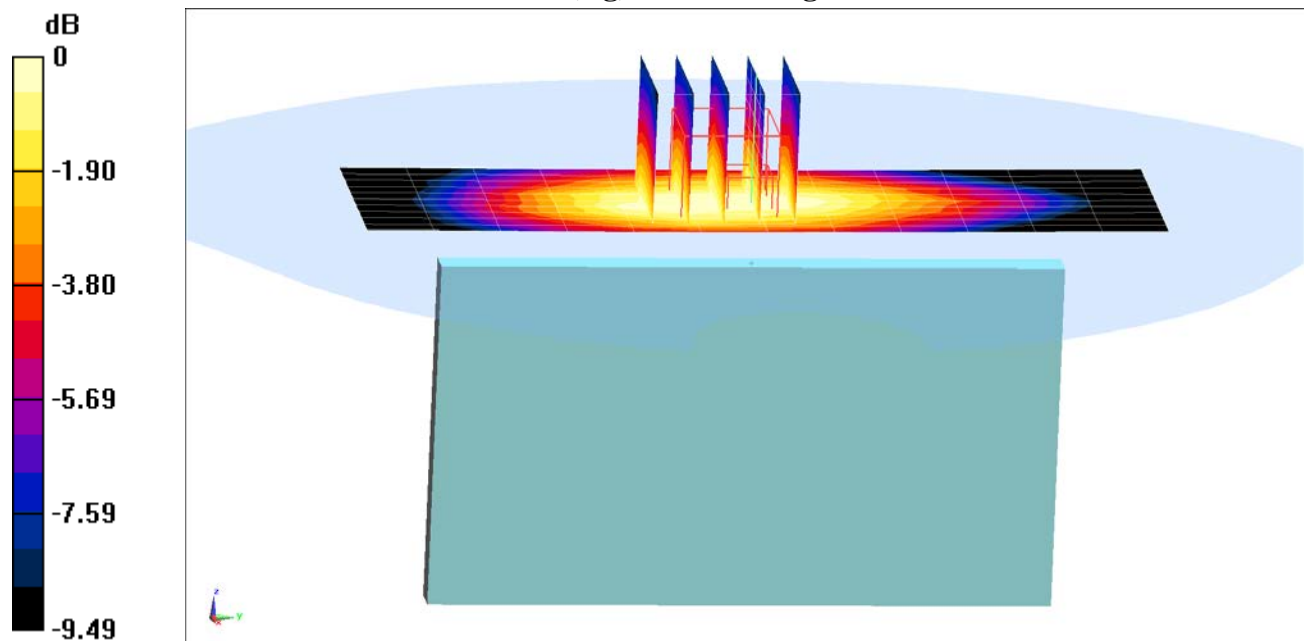

0 dB = 0.792 W/kg = -1.01 dBW/kg

PCTEST ENGINEERING LABORATORY, INC.

DUT: ZNFH636; Type: Portable Handset; Serial: 1TU8K

Communication System: UID 0, LTE Band 4 (AWS); Frequency: 1732.5 MHz; Duty Cycle: 1:1
Medium: 1750 Body Medium parameters used (interpolated):
 $f = 1732.5 \text{ MHz}$; $\sigma = 1.497 \text{ S/m}$; $\epsilon_r = 52.947$; $\rho = 1000 \text{ kg/m}^3$
Phantom section: Flat Section; Space: 1.0 cm

Test Date: 03-25-2015; Ambient Temp: 23.3°C; Tissue Temp: 21.4°C

Probe: ES3DV3 - SN3334; ConvF(4.94, 4.94, 4.94); Calibrated: 12/16/2014;
Sensor-Surface: 3mm (Mechanical Surface Detection)
Electronics: DAE4 Sn1415; Calibrated: 12/12/2014
Phantom: ELI v5.0; Type: QDOVA001BB; Serial: 1158
Measurement SW: DASY52, Version 52.8 (8); SEMCAD X Version 14.6.10 (7331)

Mode: LTE Band 4 (AWS), Body SAR, Back side, Mid.ch
20 MHz Bandwidth, QPSK, 1 RB, 0 RB Offset

Area Scan (9x13x1): Measurement grid: dx=15mm, dy=15mm

Zoom Scan (5x6x7)/Cube 0: Measurement grid: dx=8mm, dy=8mm, dz=5mm

Reference Value = 24.63 V/m; Power Drift = 0.18 dB

Peak SAR (extrapolated) = 1.22 W/kg

SAR (1 g) = 0.838 W/kg

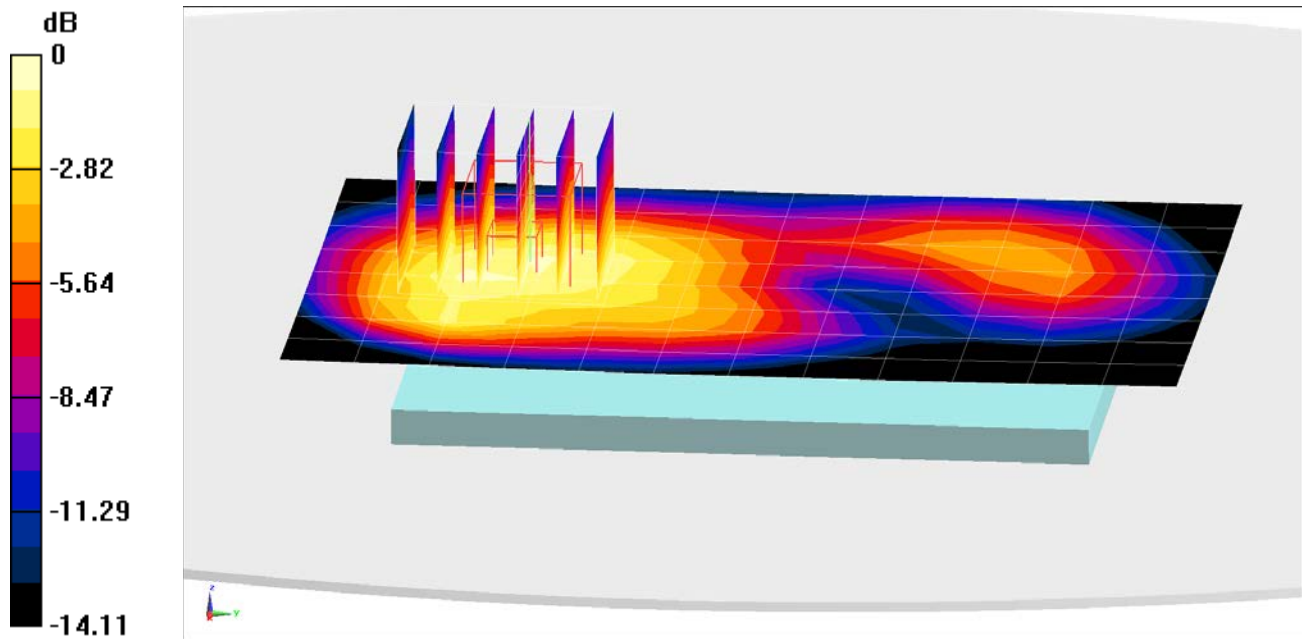

0 dB = 0.967 W/kg = -0.15 dBW/kg

PCTEST ENGINEERING LABORATORY, INC.

DUT: ZNFH636; Type: Portable Handset; Serial: 1TU8K

Communication System: UID 0, LTE Band 2 (PCS); Frequency: 1880 MHz; Duty Cycle: 1:1
Medium: 1900 Body Medium parameters used:
 $f = 1880 \text{ MHz}$; $\sigma = 1.537 \text{ S/m}$; $\epsilon_r = 51.957$; $\rho = 1000 \text{ kg/m}^3$
Phantom section: Flat Section; Space: 1.0 cm

Test Date: 03-23-2015; Ambient Temp: 23.3°C; Tissue Temp: 21.7°C

Probe: ES3DV2 - SN3022; ConvF(4.49, 4.49, 4.49); Calibrated: 8/19/2014;
Sensor-Surface: 3mm (Mechanical Surface Detection)
Electronics: DAE4 Sn1322; Calibrated: 8/12/2014
Phantom: ELI v5.0; Type: QDOVA001BB; Serial: 1226
Measurement SW: DASYS2, Version 52.8 (8); SEMCAD X Version 14.6.10 (7331)

Mode: LTE Band 2 (PCS), Body SAR, Back side, Mid.ch
20 MHz Bandwidth, QPSK, 1 RB, 99 RB Offset

Area Scan (8x14x1): Measurement grid: dx=15mm, dy=15mm
Zoom Scan (5x5x7)/Cube 0: Measurement grid: dx=8mm, dy=8mm, dz=5mm
Reference Value = 23.16 V/m; Power Drift = -0.04 dB
Peak SAR (extrapolated) = 1.23 W/kg
SAR (1 g) = 0.714 W/kg

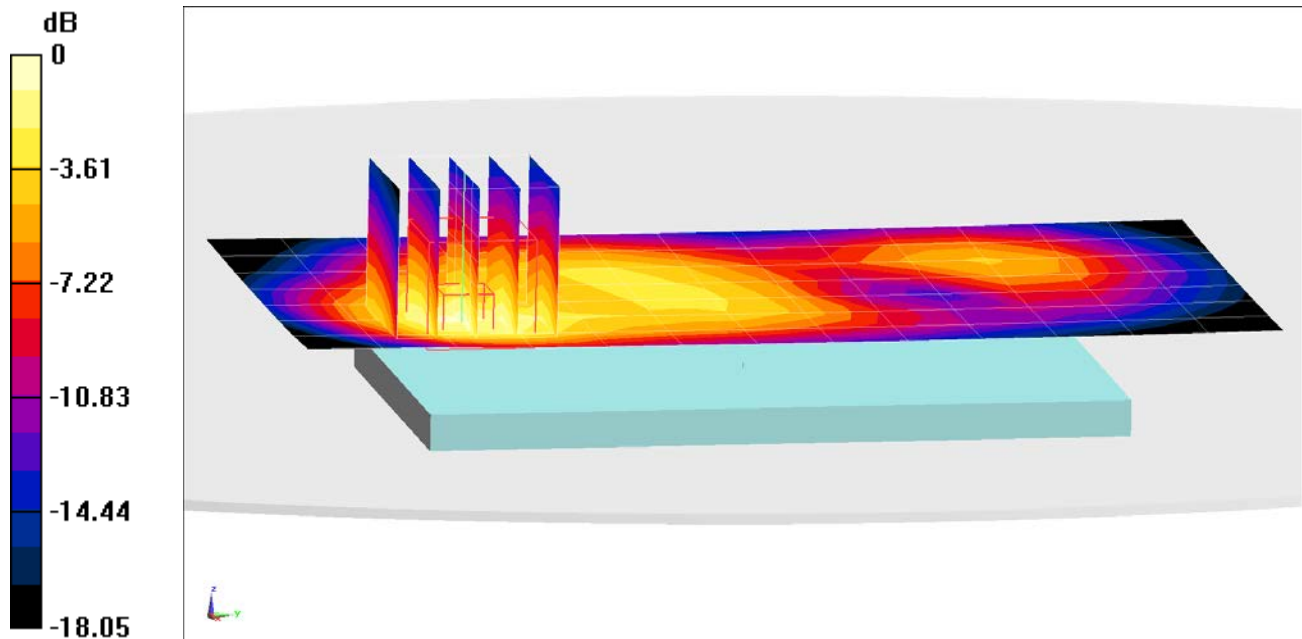

0 dB = 0.885 W/kg = -0.53 dBW/kg

PCTEST ENGINEERING LABORATORY, INC.

DUT: ZNFH636; Type: Portable Handset; Serial: 1TU8K

Communication System: UID 0, LTE Band 7; Frequency: 2510 MHz; Duty Cycle: 1:1
Medium: 2500 Body Medium parameters used (interpolated):
 $f = 2510 \text{ MHz}$; $\sigma = 2.118 \text{ S/m}$; $\epsilon_r = 50.857$; $\rho = 1000 \text{ kg/m}^3$
Phantom section: Flat Section; Space: 1.0 cm

Test Date: 03-25-2015; Ambient Temp: 22.9°C; Tissue Temp: 21.2°C

Probe: ES3DV3 - SN3213; ConvF(4.37, 4.37, 4.37); Calibrated: 1/20/2015;
Sensor-Surface: 3mm (Mechanical Surface Detection)
Electronics: DAE4 Sn1407; Calibrated: 1/19/2015
Phantom: ELI v6.0; Type: QDOVA003AA; Serial: TP:2027
Measurement SW: DASYS2, Version 52.8 (8); SEMCAD X Version 14.6.10 (7331)

Mode: LTE Band 7, Body SAR, Back side, Low.ch
20 MHz Bandwidth, QPSK, 1 RB, 50 RB Offset

Area Scan (11x18x1): Measurement grid: dx=12mm, dy=12mm

Zoom Scan (7x7x7)/Cube 0: Measurement grid: dx=5mm, dy=5mm, dz=5mm

Reference Value = 18.72 V/m; Power Drift = -0.15 dB

Peak SAR (extrapolated) = 1.40 W/kg

SAR (1 g) = 0.386 W/kg

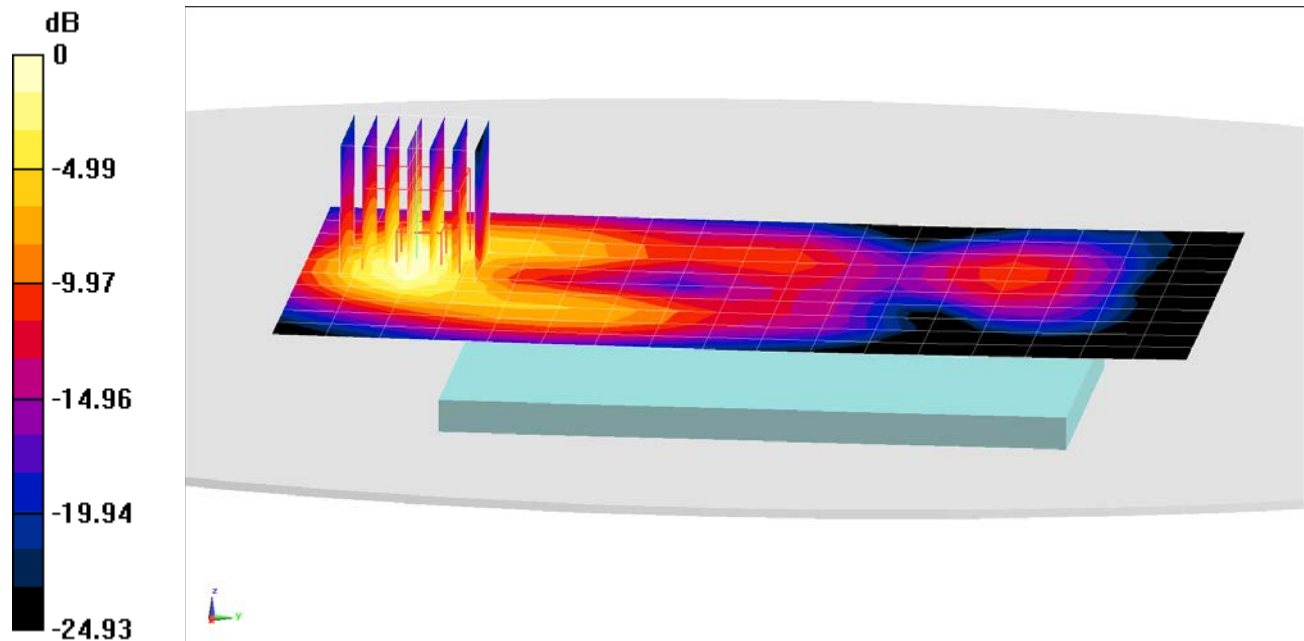

0 dB = 0.848 W/kg = -0.72 dBW/kg

PCTEST ENGINEERING LABORATORY, INC.

DUT: ZNFH636; Type: Portable Handset; Serial: 1TU8Q

Communication System: UID 0, IEEE 802.11b; Frequency: 2437 MHz; Duty Cycle: 1:1
Medium: 2450 Body Medium parameters used (interpolated):
 $f = 2437 \text{ MHz}$; $\sigma = 2.009 \text{ S/m}$; $\epsilon_r = 50.848$; $\rho = 1000 \text{ kg/m}^3$
Phantom section: Flat Section; Space: 1.0 cm

Test Date: 03-17-2015; Ambient Temp: 23.1°C; Tissue Temp: 22.4°C

Probe: ES3DV3 - SN3213; ConvF(4.37, 4.37, 4.37); Calibrated: 1/20/2015;
Sensor-Surface: 3mm (Mechanical Surface Detection)
Electronics: DAE4 Sn1407; Calibrated: 1/19/2015
Phantom: SAM Front; Type: SAM; Serial: 1686
Measurement SW: DASY52, Version 52.8 (8); SEMCAD X Version 14.6.10 (7331)

**Mode: IEEE 802.11b, Body SAR, Ch 6, 1 Mbps
22 MHz Bandwidth, Back Side**

Area Scan (11x17x1): Measurement grid: dx=12mm, dy=12mm

Zoom Scan (7x7x7)/Cube 0: Measurement grid: dx=5mm, dy=5mm, dz=5mm

Reference Value = 7.434 V/m; Power Drift = -0.09 dB

Peak SAR (extrapolated) = 0.209 W/kg

SAR (1 g) = 0.094 W/kg

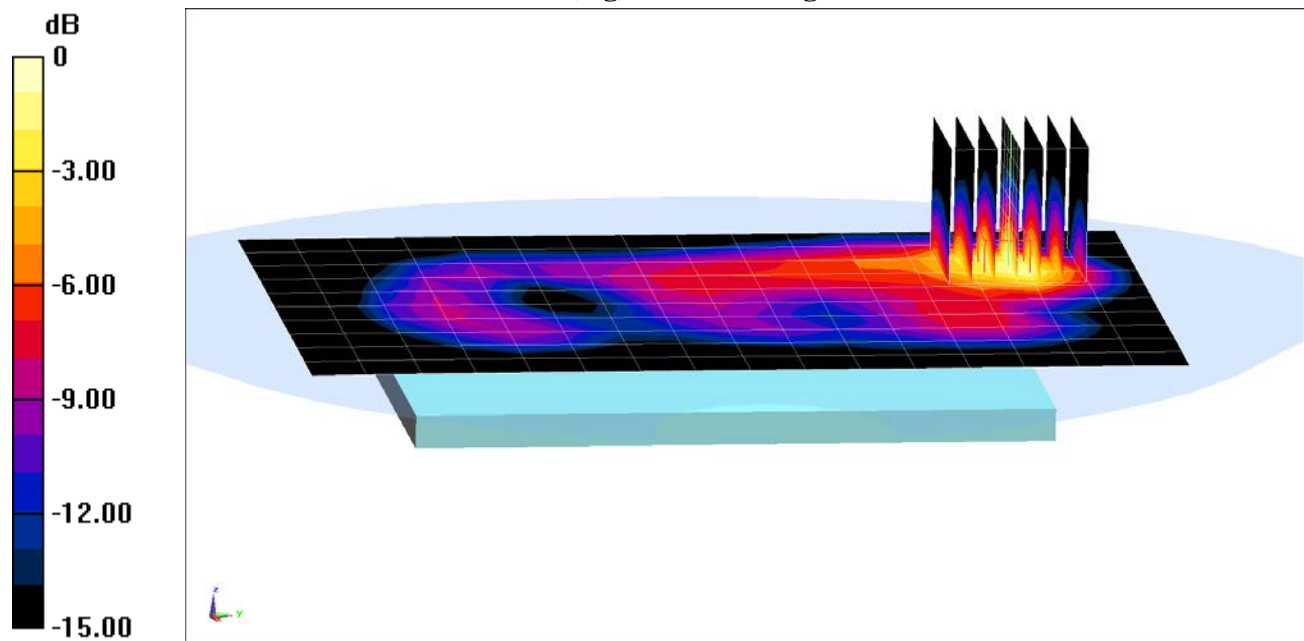

0 dB = 0.127 W/kg = -8.96 dBW/kg

PCTEST ENGINEERING LABORATORY, INC.

DUT: ZNFH636; Type: Portable Handset; Serial: 1TU8Q

Communication System: UID 0, IEEE 802.11n; Frequency: 5795 MHz; Duty Cycle: 1:1
Medium: 5GHz Body Medium parameters used (interpolated):
 $f = 5795 \text{ MHz}$; $\sigma = 6.058 \text{ S/m}$; $\epsilon_r = 46.122$; $\rho = 1000 \text{ kg/m}^3$
Phantom section: Flat Section; Space: 1.0 cm

Test Date: 03-31-2015; Ambient Temp: 24.4°C; Tissue Temp: 20.6°C

Probe: EX3DV4 - SN3914; ConvF(4.01, 4.01, 4.01); Calibrated: 2/10/2015;
Sensor-Surface: 1.4mm (Mechanical Surface Detection)
Electronics: DAE4 Sn1333; Calibrated: 10/31/2014
Phantom: SAM Sub; Type: QD000P40CC; Serial: TP:1357
Measurement SW: DASY52, Version 52.8 (8); SEMCAD X Version 14.6.10 (7331)

**Mode: IEEE 802.11n, 5.8 GHz, Body SAR, Ch 159, 13.5 Mbps
40 MHz Bandwidth, Back Side**

Area Scan (13x21x1): Measurement grid: dx=10mm, dy=10mm

Zoom Scan (7x7x7)/Cube 0: Measurement grid: dx=4mm, dy=4mm, dz=1.4mm; Graded Ratio = 1.4
Reference Value = 3.717 V/m; Power Drift = -0.09 dB
Peak SAR (extrapolated) = 0.418 W/kg
SAR (1 g) = 0.090 W/kg

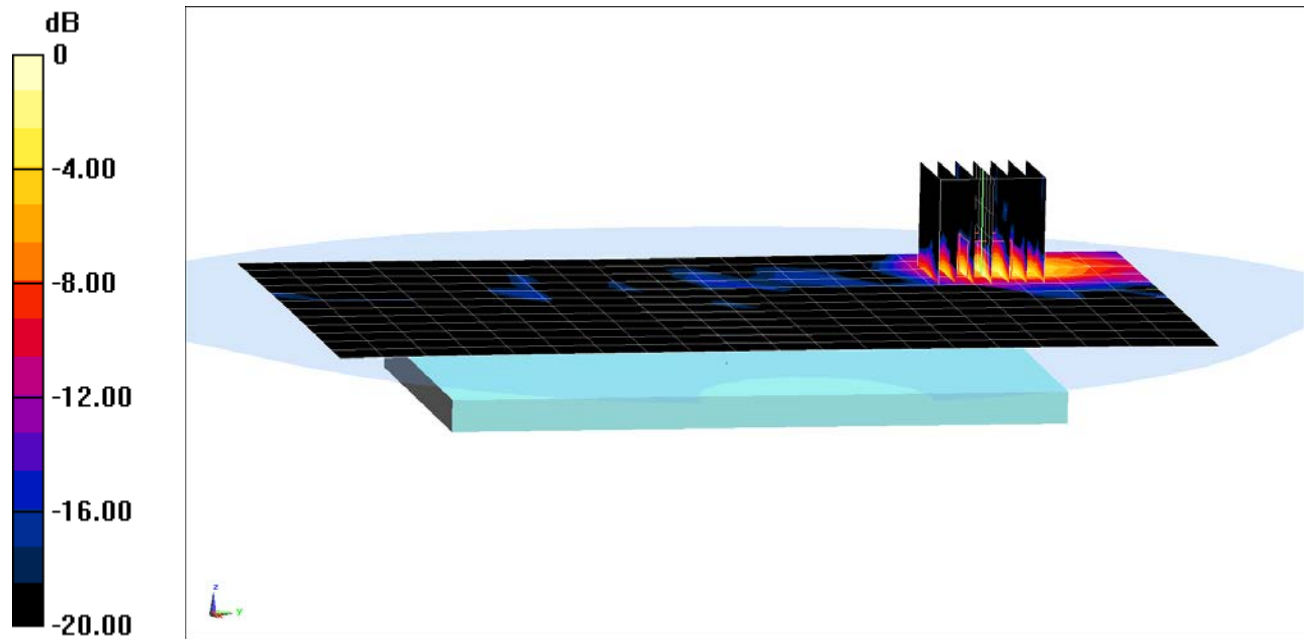

0 dB = 0.245 W/kg = -6.11 dBW/kg

PCTEST ENGINEERING LABORATORY, INC.

DUT: ZNFH636; Type: Portable Handset; Serial: 1MKUW

Communication System: UID 0, Bluetooth; Frequency: 2441 MHz; Duty Cycle: 1:1
Medium: 2450 Body Medium parameters used (interpolated):
 $f = 2441 \text{ MHz}$; $\sigma = 2.029 \text{ S/m}$; $\epsilon_r = 50.807$; $\rho = 1000 \text{ kg/m}^3$
Phantom section: Flat Section; Space: 1.0 cm

Test Date: 04-20-2015; Ambient Temp: 23.4°C; Tissue Temp: 22.5°C

Probe: ES3DV3 - SN3334; ConvF(4.28, 4.28, 4.28); Calibrated: 12/16/2014;
Sensor-Surface: 3mm (Mechanical Surface Detection)
Electronics: DAE4 Sn1415; Calibrated: 12/12/2014
Phantom: Sub Twin Sam v5.0; Type: QD000P40CD; Serial: TP:1626
Measurement SW: DASY52, Version 52.8 (8); SEMCAD X Version 14.6.10 (7331)

Mode: Bluetooth, Body SAR, Ch 39, 1 Mbps, Back Side

Area Scan (11x17x1): Measurement grid: $dx=12\text{mm}$, $dy=12\text{mm}$

Zoom Scan (7x7x7)/Cube 0: Measurement grid: $dx=5\text{mm}$, $dy=5\text{mm}$, $dz=5\text{mm}$

Reference Value = 2.160 V/m; Power Drift = 0.16 dB

Peak SAR (extrapolated) = 0.0230 W/kg

SAR (1 g) = 0.010 W/kg

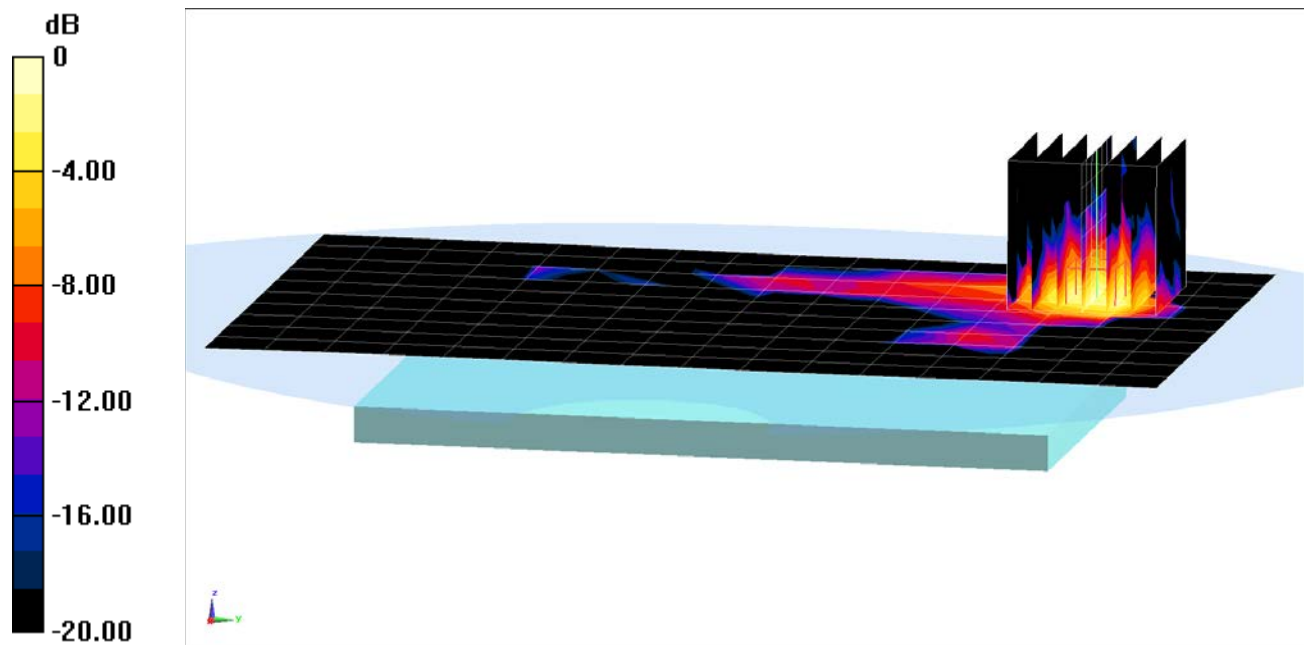

0 dB = 0.0149 W/kg = -18.27 dBW/kg

PCTEST ENGINEERING LABORATORY, INC.

DUT: ZNFH636; Type: Portable Handset; Serial: 1TU8Q

Communication System: UID 0, IEEE 802.11n; Frequency: 5510 MHz; Duty Cycle: 1:1
Medium: 5GHz Body Medium parameters used (interpolated):
 $f = 5510 \text{ MHz}$; $\sigma = 5.707 \text{ S/m}$; $\epsilon_r = 46.523$; $\rho = 1000 \text{ kg/m}^3$
Phantom section: Flat Section; Space: 0.0 cm

Test Date: 03-31-2015; Ambient Temp: 24.3°C; Tissue Temp: 20.8°C

Probe: EX3DV4 - SN3914; ConvF(3.91, 3.91, 3.91); Calibrated: 2/10/2015;
Sensor-Surface: 1.4mm (Mechanical Surface Detection)
Electronics: DAE4 Sn1333; Calibrated: 10/31/2014
Phantom: SAM Sub ; Type: QD000P40CC; Serial: TP:1357
Measurement SW: DASY52, Version 52.8 (8); SEMCAD X Version 14.6.10 (7331)

**Mode: IEEE 802.11n, 5.5 GHz, Extremity SAR, Ch 102, 13.5 Mbps
40 MHz Bandwidth, Back Side**

Area Scan (13x19x1): Measurement grid: dx=10mm, dy=10mm

Zoom Scan (8x8x7)/Cube 0: Measurement grid: dx=4mm, dy=4mm, dz=1.4mm; Graded Ratio = 1.4
Reference Value = 15.44 V/m; Power Drift = 0.14 dB
Peak SAR (extrapolated) = 8.34 W/kg
SAR (10 g) = 0.208 W/kg

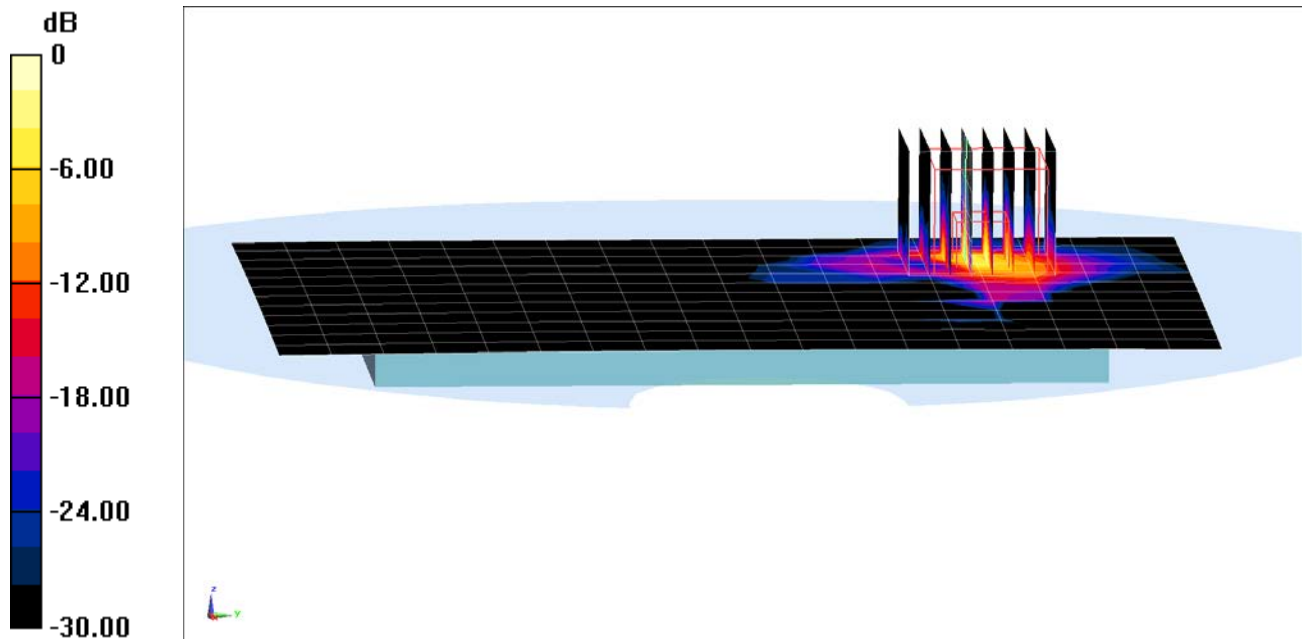

0 dB = 3.71 W/kg = 5.69 dBW/kg

PCTEST ENGINEERING LABORATORY, INC.

DUT: ZNFH636; Type: Portable Handset; Serial: 1MKUW

Communication System: UID 0, Bluetooth; Frequency: 2441 MHz; Duty Cycle: 1:1
Medium: 2450 Body Medium parameters used (interpolated):
 $f = 2441 \text{ MHz}$; $\sigma = 2.029 \text{ S/m}$; $\epsilon_r = 50.807$; $\rho = 1000 \text{ kg/m}^3$
Phantom section: Flat Section; Space: 0.0 cm

Test Date: 04-20-2015; Ambient Temp: 23.4°C; Tissue Temp: 22.5°C

Probe: ES3DV3 - SN3334; ConvF(4.28, 4.28, 4.28); Calibrated: 12/16/2014;
Sensor-Surface: 3mm (Mechanical Surface Detection)
Electronics: DAE4 Sn1415; Calibrated: 12/12/2014
Phantom: Sub Twin Sam v5.0; Type: QD000P40CD; Serial: TP:1626
Measurement SW: DASY52, Version 52.8 (8); SEMCAD X Version 14.6.10 (7331)

Mode: Bluetooth, Extremity SAR, Ch 39, 1 Mbps, Back Side

Area Scan (11x17x1): Measurement grid: dx=12mm, dy=12mm
Zoom Scan (7x7x7)/Cube 0: Measurement grid: dx=5mm, dy=5mm, dz=5mm
Reference Value = 6.206 V/m; Power Drift = 0.01 dB
Peak SAR (extrapolated) = 0.346 W/kg
SAR (10 g) = 0.035 W/kg

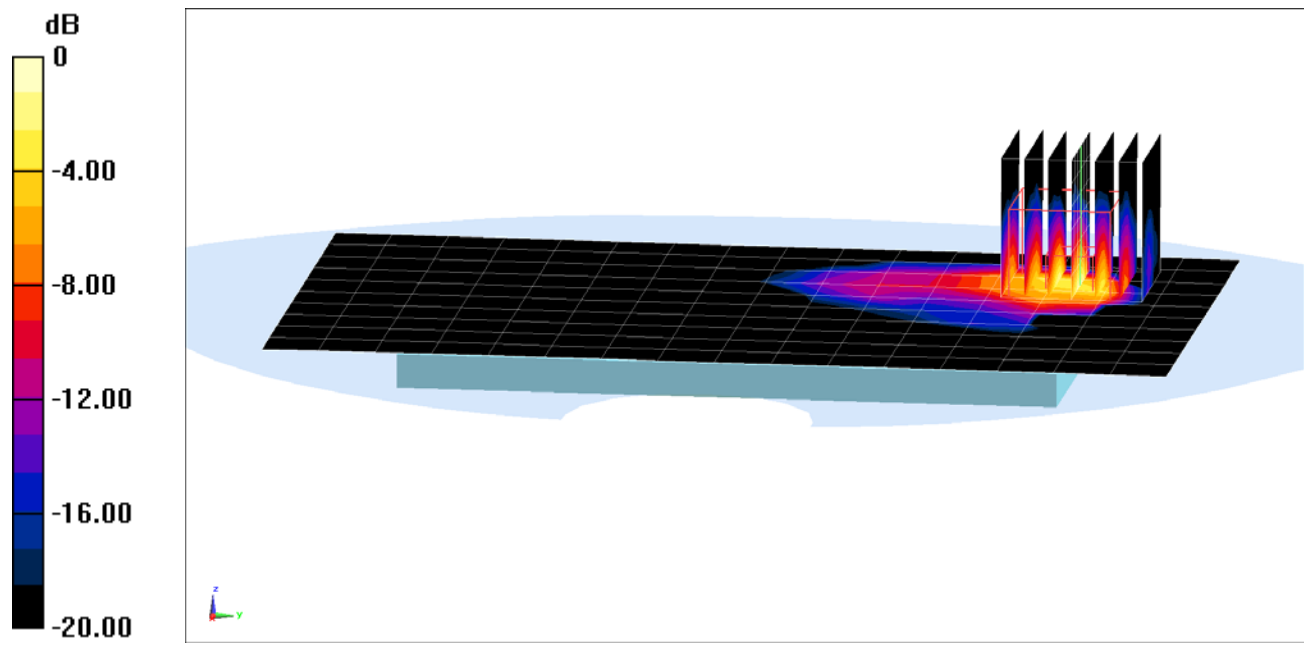

0 dB = 0.165 W/kg = -7.83 dBW/kg

APPENDIX B: SYSTEM VERIFICATION

PCTEST ENGINEERING LABORATORY, INC.

DUT: Dipole 750 MHz; Type: D750V3; Serial: 1003

Communication System: UID 0, CW; Frequency: 750 MHz; Duty Cycle: 1:1

Medium: 750 Head Medium parameters used (interpolated):

$f = 750 \text{ MHz}$; $\sigma = 0.907 \text{ S/m}$; $\epsilon_r = 40.97$; $\rho = 1000 \text{ kg/m}^3$

Phantom section: Flat Section; Space: 1.5 cm

Test Date: 03-25-2015; Ambient Temp: 22.9°C; Tissue Temp: 21.8°C

Probe: ES3DV2 - SN3022; ConvF(6.39, 6.39, 6.39); Calibrated: 8/19/2014;

Sensor-Surface: 3mm (Mechanical Surface Detection)

Electronics: DAE4 Sn1322; Calibrated: 8/12/2014

Phantom: SAM with CRP v4.0; Type: QD000P40CD; Serial: TP:1800

Measurement SW: DASY52, Version 52.8 (8); SEMCAD X Version 14.6.10 (7331)

750 MHz System Verification

Area Scan (7x15x1): Measurement grid: dx=15mm, dy=15mm

Zoom Scan (5x5x7)/Cube 0: Measurement grid: dx=8mm, dy=8mm, dz=5mm

Input Power = 20 dBm (100 mW)

Peak SAR (extrapolated) = 1.27 W/kg

SAR (1 g) = 0.856 W/kg

Deviation = 5.81%

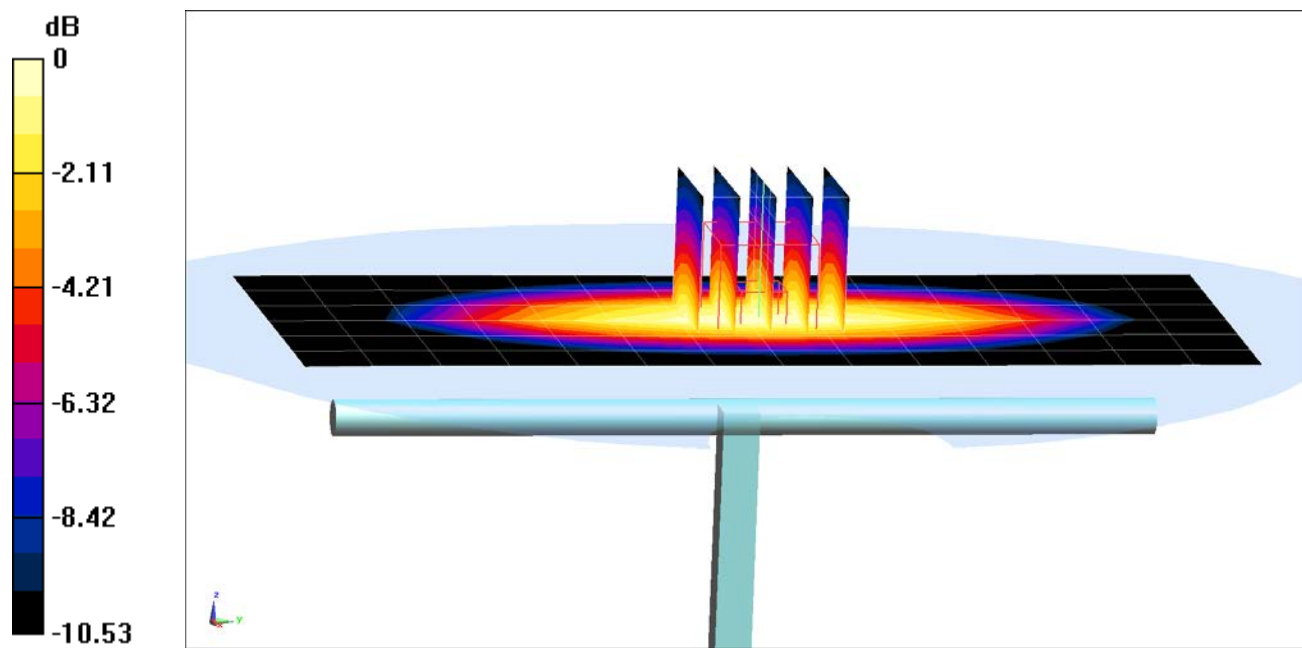

0 dB = 1.00 W/kg = 0.00 dBW/kg

PCTEST ENGINEERING LABORATORY, INC.

DUT: Dipole 835 MHz; Type: D835V2; Serial: 4d133

Communication System: UID 0, CW; Frequency: 835 MHz; Duty Cycle: 1:1

Medium: 835 Head Medium parameters used:

$f = 835 \text{ MHz}$; $\sigma = 0.899 \text{ S/m}$; $\epsilon_r = 40.279$; $\rho = 1000 \text{ kg/m}^3$

Phantom section: Flat Section; Space: 1.5 cm

Test Date: 03-25-2015; Ambient Temp: 22.8°C; Tissue Temp: 22.0°C

Probe: ES3DV3 - SN3288; ConvF(6.51, 6.51, 6.51); Calibrated: 9/24/2014;

Sensor-Surface: 3mm (Mechanical Surface Detection)

Electronics: DAE4 Sn1364; Calibrated: 9/18/2014

Phantom: SAM with CRP v4.0; Type: QD000P40CD; Serial: TP:1797

Measurement SW: DASY52, Version 52.8 (8); SEMCAD X Version 14.6.10 (7331)

835 MHz System Verification

Area Scan (7x14x1): Measurement grid: dx=15mm, dy=15mm

Zoom Scan (5x5x7)/Cube 0: Measurement grid: dx=8mm, dy=8mm, dz=5mm

Input Power = 20 dBm (100 mW)

Peak SAR (extrapolated) = 1.40 W/kg

SAR (1 g) = 0.945 W/kg

Deviation = 2.72%

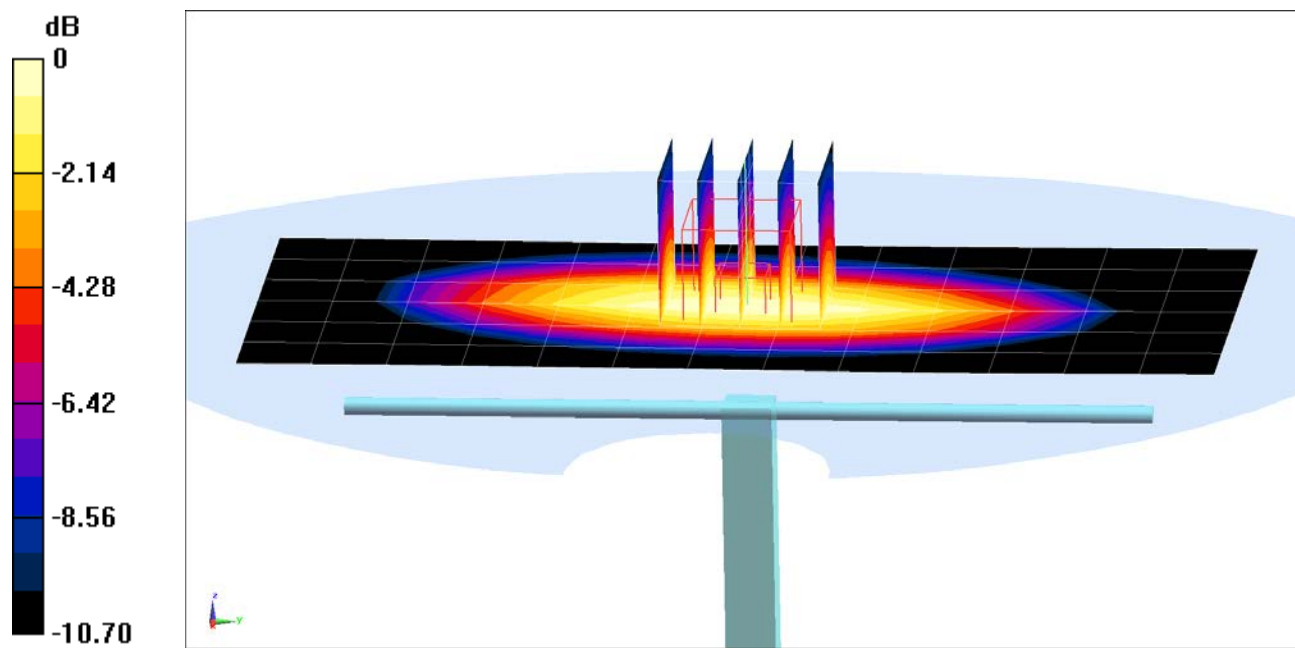

0 dB = 1.11 W/kg = 0.45 dBW/kg

PCTEST ENGINEERING LABORATORY, INC.

DUT: Dipole 1750 MHz; Type: D1750V2; Serial: 1051

Communication System: UID 0, CW; Frequency: 1750 MHz; Duty Cycle: 1:1
Medium: 1750 Head Medium parameters used:
 $f = 1750 \text{ MHz}$; $\sigma = 1.409 \text{ S/m}$; $\epsilon_r = 38.615$; $\rho = 1000 \text{ kg/m}^3$
Phantom section: Flat Section; Space: 1.0 cm

Test Date: 03-23-2015; Ambient Temp: 23.4°C; Tissue Temp: 20.4°C

Probe: ES3DV3 - SN3334; ConvF(5.21, 5.21, 5.21); Calibrated: 12/16/2014;
Sensor-Surface: 3mm (Mechanical Surface Detection)
Electronics: DAE4 Sn1415; Calibrated: 12/12/2014
Phantom: Sub Twin Sam v5.0; Type: QD000P40CD; Serial: TP:1626
Measurement SW: DASY52, Version 52.8 (8); SEMCAD X Version 14.6.10 (7331)

1750 MHz System Verification

Area Scan (7x9x1): Measurement grid: dx=15mm, dy=15mm

Zoom Scan (5x5x7)/Cube 0: Measurement grid: dx=8mm, dy=8mm, dz=5mm

Input Power = 20 dBm (100 mW)

Peak SAR (extrapolated) = 7.05 W/kg

SAR (1 g) = 3.86 W/kg

Deviation = 6.63%

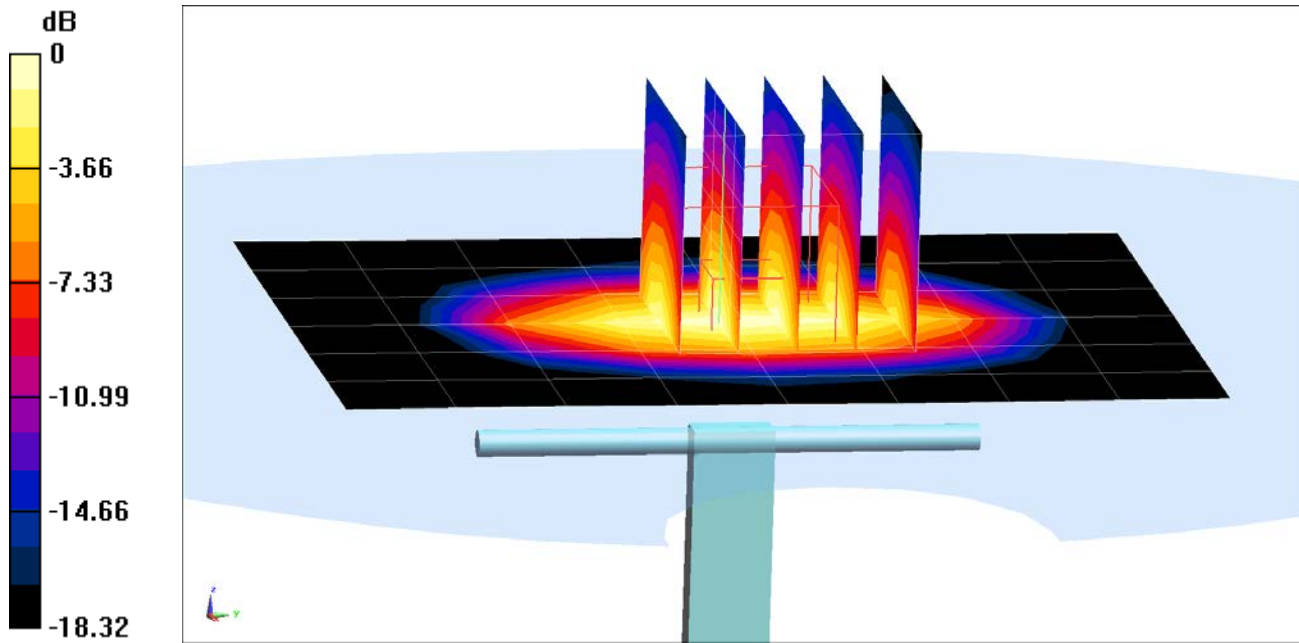

0 dB = 4.81 W/kg = 6.82 dBW/kg

PCTEST ENGINEERING LABORATORY, INC.

DUT: Dipole 1900 MHz; Type: D1900V2; Serial: 5d141

Communication System: UID 0, CW; Frequency: 1900 MHz; Duty Cycle: 1:1

Medium: 1900 Head Medium parameters used (interpolated):

$f = 1900 \text{ MHz}$; $\sigma = 1.432 \text{ S/m}$; $\epsilon_r = 39.953$; $\rho = 1000 \text{ kg/m}^3$

Phantom section: Flat Section; Space: 1.0 cm

Test Date: 03-23-2015; Ambient Temp: 22.6°C; Tissue Temp: 21.6°C

Probe: ES3DV3 - SN3213; ConvF(5.06, 5.06, 5.06); Calibrated: 1/20/2015;

Sensor-Surface: 3mm (Mechanical Surface Detection)

Electronics: DAE4 Sn1407; Calibrated: 1/19/2015

Phantom: SAM Front; Type: SAM; Serial: 1686

Measurement SW: DASY52, Version 52.8 (8); SEMCAD X Version 14.6.10 (7331)

1900 MHz System Verification

Area Scan (7x9x1): Measurement grid: dx=15mm, dy=15mm

Zoom Scan (5x5x7)/Cube 0: Measurement grid: dx=8mm, dy=8mm, dz=5mm

Input Power = 20 dBm (100 mW)

Peak SAR (extrapolated) = 7.72 W/kg

SAR (1 g) = 4.24 W/kg

Deviation = 5.74%

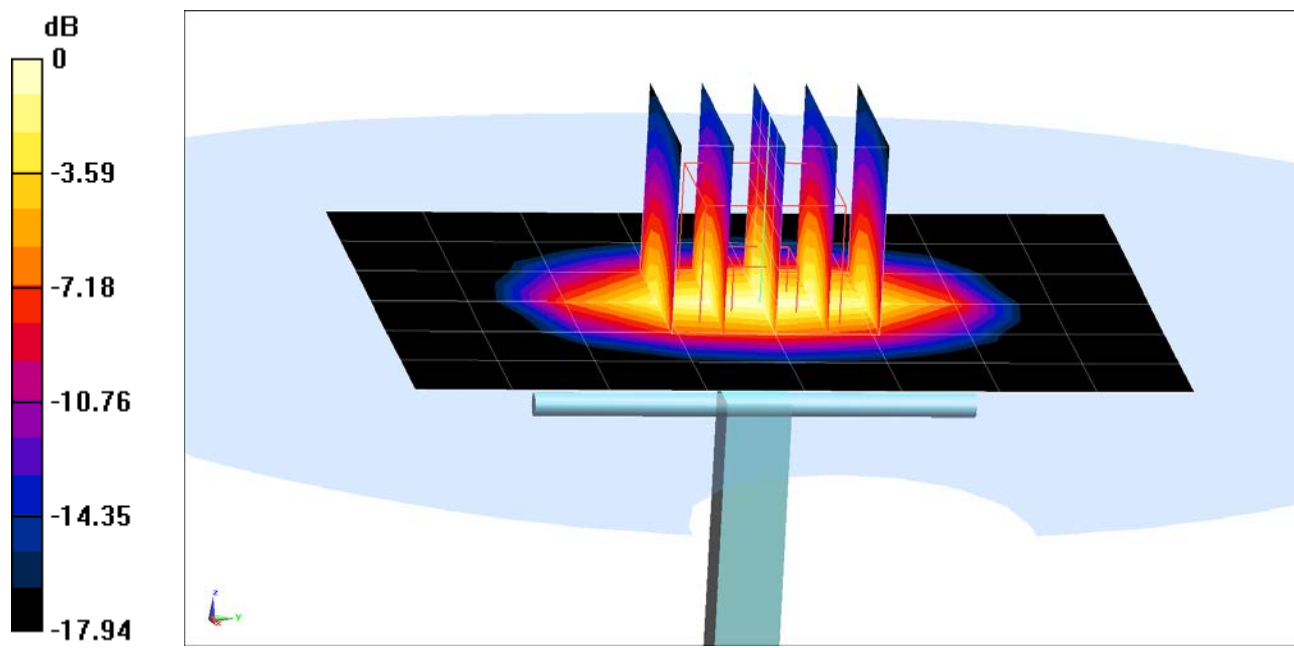

0 dB = 5.39 W/kg = 7.32 dBW/kg

PCTEST ENGINEERING LABORATORY, INC.

DUT: Dipole 2450 MHz; Type: D2450V2; Serial: 719

Communication System: UID 0, CW; Frequency: 2450 MHz; Duty Cycle: 1:1

Medium: 2450 Head Medium parameters used:

$f = 2450 \text{ MHz}$; $\sigma = 1.829 \text{ S/m}$; $\epsilon_r = 38.982$; $\rho = 1000 \text{ kg/m}^3$

Phantom section: Flat Section; Space: 1.0 cm

Test Date: 03-23-2015; Ambient Temp: 23.1°C; Tissue Temp: 21.4°C

Probe: ES3DV3 - SN3288; ConvF(4.56, 4.56, 4.56); Calibrated: 9/24/2014;

Sensor-Surface: 3mm (Mechanical Surface Detection)

Electronics: DAE4 Sn1364; Calibrated: 9/18/2014

Phantom: SAM with CRP v4.0; Type: QD000P40CD; Serial: TP:1797

Measurement SW: DASY52, Version 52.8 (8); SEMCAD X Version 14.6.10 (7331)

2450 MHz System Verification

Area Scan (8x9x1): Measurement grid: dx=12mm, dy=12mm

Zoom Scan (7x7x7)/Cube 0: Measurement grid: dx=5mm, dy=5mm, dz=5mm

Input Power = 20 dBm (100 mW)

Peak SAR (extrapolated) = 11.7 W/kg

SAR (1 g) = 5.59 W/kg

Deviation = 7.29%

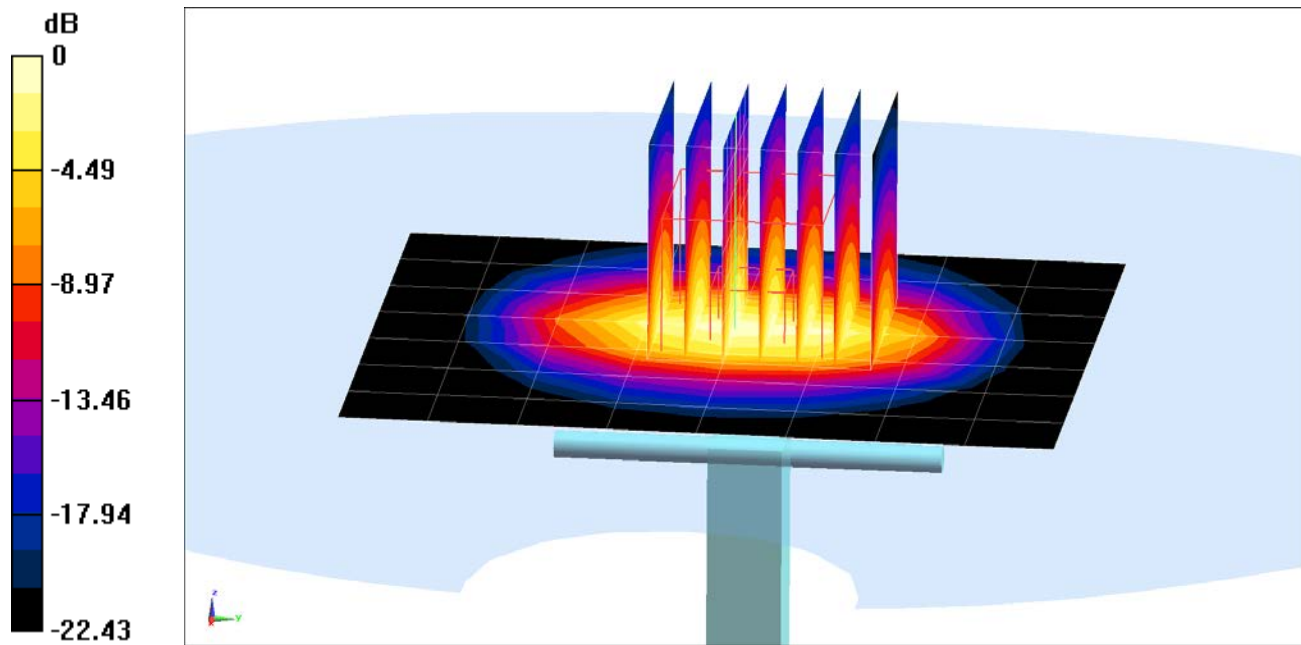

0 dB = 7.32 W/kg = 8.65 dBW/kg

PCTEST ENGINEERING LABORATORY, INC.

DUT: Dipole 5300 MHz; Type: D5GHzV2; Serial: 1057

Communication System: UID 0, CW; Frequency: 5300 MHz; Duty Cycle: 1:1
Medium: 5GHz Head Medium parameters used:
 $f = 5300 \text{ MHz}$; $\sigma = 4.691 \text{ S/m}$; $\epsilon_r = 36.654$; $\rho = 1000 \text{ kg/m}^3$
Phantom section: Flat Section; Space: 1.0 cm

Test Date: 03-26-2015; Ambient Temp: 22.6°C; Tissue Temp: 21.0°C

Probe: EX3DV4 - SN3920; ConvF(4.69, 4.69, 4.69); Calibrated: 12/12/2014;
Sensor-Surface: 1.4mm (Mechanical Surface Detection)
Electronics: DAE4 Sn665; Calibrated: 2/18/2015
Phantom: SAM, Left; Type: QD000P40CD; Serial: TP:1759
Measurement SW: DASY52, Version 52.8 (8); SEMCAD X Version 14.6.10 (7331)

5300 MHz System Verification

Area Scan (7x8x1): Measurement grid: dx=10mm, dy=10mm

Zoom Scan (8x8x7)/Cube 0: Measurement grid: dx=4mm, dy=4mm, dz=1.4mm; Graded Ratio = 1.4

Input Power = 17 dBm (50 mW)

Peak SAR (extrapolated) = 16.8 W/kg

SAR (1 g) = 4.06 W/kg

Deviation (1 g) = -4.13%

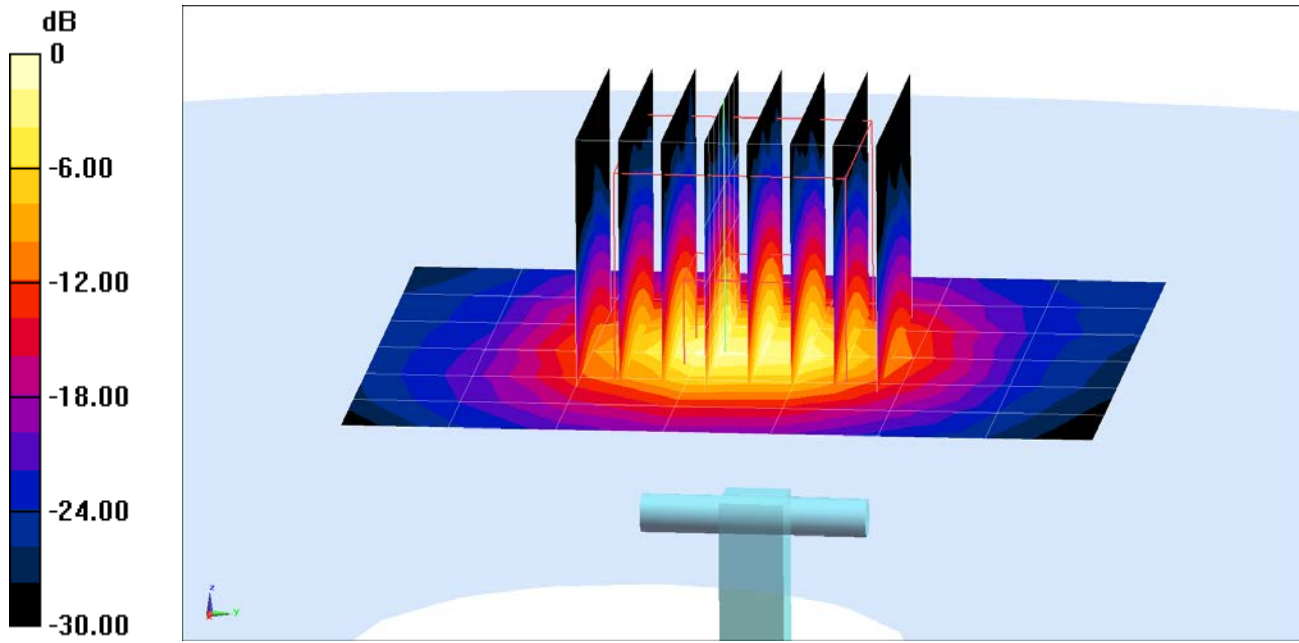

0 dB = 9.34 W/kg = 9.70 dBW/kg

PCTEST ENGINEERING LABORATORY, INC.

DUT: Dipole 5500 MHz; Type: D5GHzV2; Serial: 1057

Communication System: UID 0, CW; Frequency: 5500 MHz; Duty Cycle: 1:1
Medium: 5GHz Head Medium parameters used:
 $f = 5500 \text{ MHz}$; $\sigma = 4.868 \text{ S/m}$; $\epsilon_r = 36.398$; $\rho = 1000 \text{ kg/m}^3$
Phantom section: Flat Section; Space: 1.0 cm

Test Date: 03-26-2015; Ambient Temp: 22.5°C; Tissue Temp: 21.2°C

Probe: EX3DV4 - SN3920; ConvF(4.44, 4.44, 4.44); Calibrated: 12/12/2014;
Sensor-Surface: 1.4mm (Mechanical Surface Detection)
Electronics: DAE4 Sn665; Calibrated: 2/18/2015
Phantom: SAM, Left; Type: QD000P40CD; Serial: TP:1759
Measurement SW: DASY52, Version 52.8 (8); SEMCAD X Version 14.6.10 (7331)

5500 MHz System Verification

Area Scan (7x7x1): Measurement grid: dx=10mm, dy=10mm

Zoom Scan (8x8x7)/Cube 0: Measurement grid: dx=4mm, dy=4mm, dz=1.4mm; Graded Ratio = 1.4

Input Power = 17 dBm (50 mW)

Peak SAR (extrapolated) = 16.4 W/kg

SAR (1 g) = 3.87 W/kg

Deviation (1 g) = -8.19%

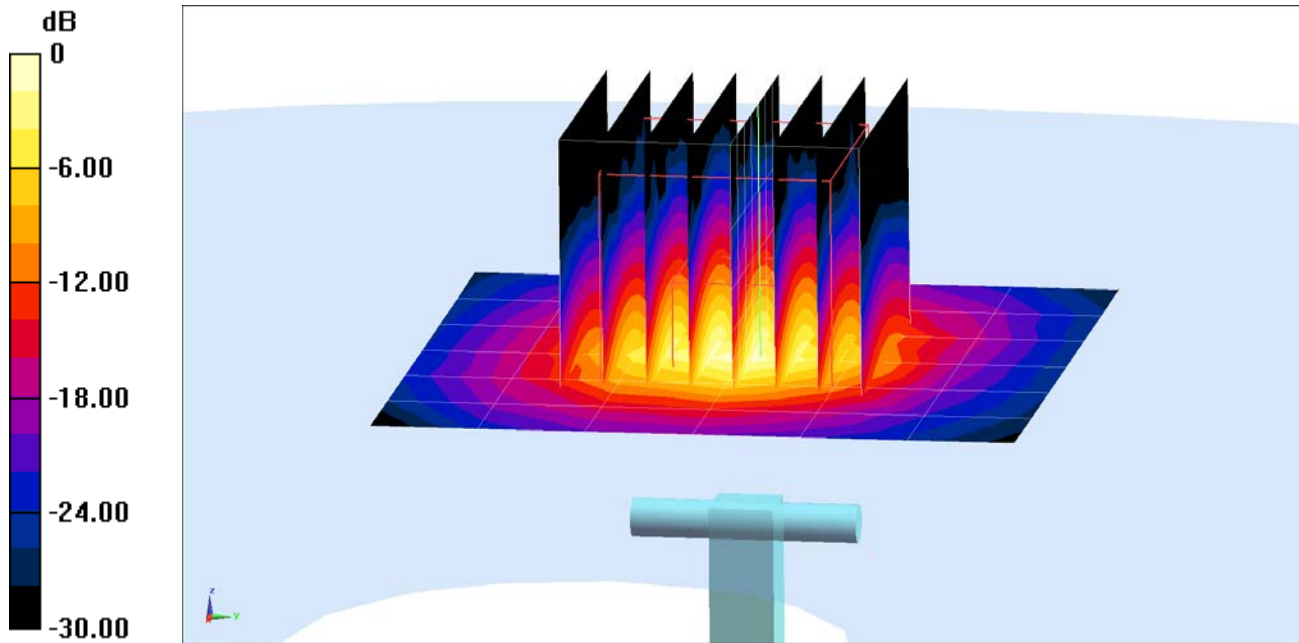

0 dB = 9.10 W/kg = 9.59 dBW/kg

PCTEST ENGINEERING LABORATORY, INC.

DUT: Dipole 5800 MHz; Type: D5GHzV2; Serial: 1057

Communication System: UID 0, CW; Frequency: 5800 MHz; Duty Cycle: 1:1
Medium: 5GHz Head Medium parameters used:
 $f = 5800 \text{ MHz}$; $\sigma = 5.201 \text{ S/m}$; $\epsilon_r = 35.955$; $\rho = 1000 \text{ kg/m}^3$
Phantom section: Flat Section; Space: 1.0 cm

Test Date: 03-26-2015; Ambient Temp: 22.7°C; Tissue Temp: 21.1°C

Probe: EX3DV4 - SN3920; ConvF(4.27, 4.27, 4.27); Calibrated: 12/12/2014;
Sensor-Surface: 1.4mm (Mechanical Surface Detection)
Electronics: DAE4 Sn665; Calibrated: 2/18/2015
Phantom: SAM, Left; Type: QD000P40CD; Serial: TP:1759
Measurement SW: DASY52, Version 52.8 (8); SEMCAD X Version 14.6.10 (7331)

5800 MHz System Verification

Area Scan (7x7x1): Measurement grid: dx=10mm, dy=10mm

Zoom Scan (8x8x7)/Cube 0: Measurement grid: dx=4mm, dy=4mm, dz=1.4mm; Graded Ratio = 1.4

Input Power = 17 dBm (50 mW)

Peak SAR (extrapolated) = 17.9 W/kg

SAR (1 g) = 3.99 W/kg

Deviation = -1.60%

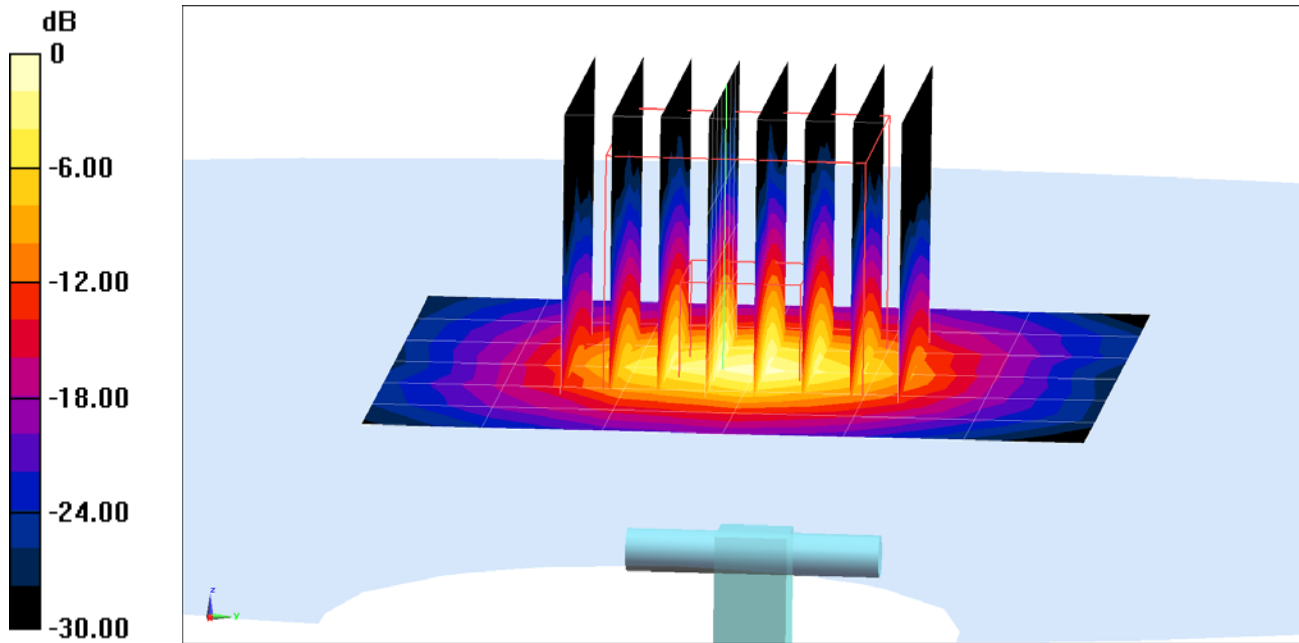

0 dB = 9.57 W/kg = 9.81 dBW/kg

PCTEST ENGINEERING LABORATORY, INC.

DUT: Dipole 750 MHz; Type: D750V3; Serial: 1003

Communication System: UID 0, CW; Frequency: 750 MHz; Duty Cycle: 1:1

Medium: 750 Body Medium parameters used (interpolated):

$f = 750 \text{ MHz}$; $\sigma = 0.973 \text{ S/m}$; $\epsilon_r = 54.927$; $\rho = 1000 \text{ kg/m}^3$

Phantom section: Flat Section; Space: 1.5 cm

Test Date: 03-24-2015; Ambient Temp: 23.0°C; Tissue Temp: 22.1°C

Probe: ES3DV3 - SN3263; ConvF(6.19, 6.19, 6.19); Calibrated: 5/15/2014;

Sensor-Surface: 3mm (Mechanical Surface Detection)

Electronics: DAE4 Sn859; Calibrated: 5/14/2014

Phantom: SAM v5.0 Left; Type: QD000P40CD; Serial: TP: 1687

Measurement SW: DASY52, Version 52.8 (8); SEMCAD X Version 14.6.10 (7331)

750 MHz System Verification

Area Scan (7x15x1): Measurement grid: $dx=15\text{mm}$, $dy=15\text{mm}$

Zoom Scan (5x5x7)/Cube 0: Measurement grid: $dx=8\text{mm}$, $dy=8\text{mm}$, $dz=5\text{mm}$

Input Power = 20 dBm (100 mW)

Peak SAR (extrapolated) = 1.35 W/kg

SAR (1 g) = 0.916 W/kg

Deviation = 8.27%

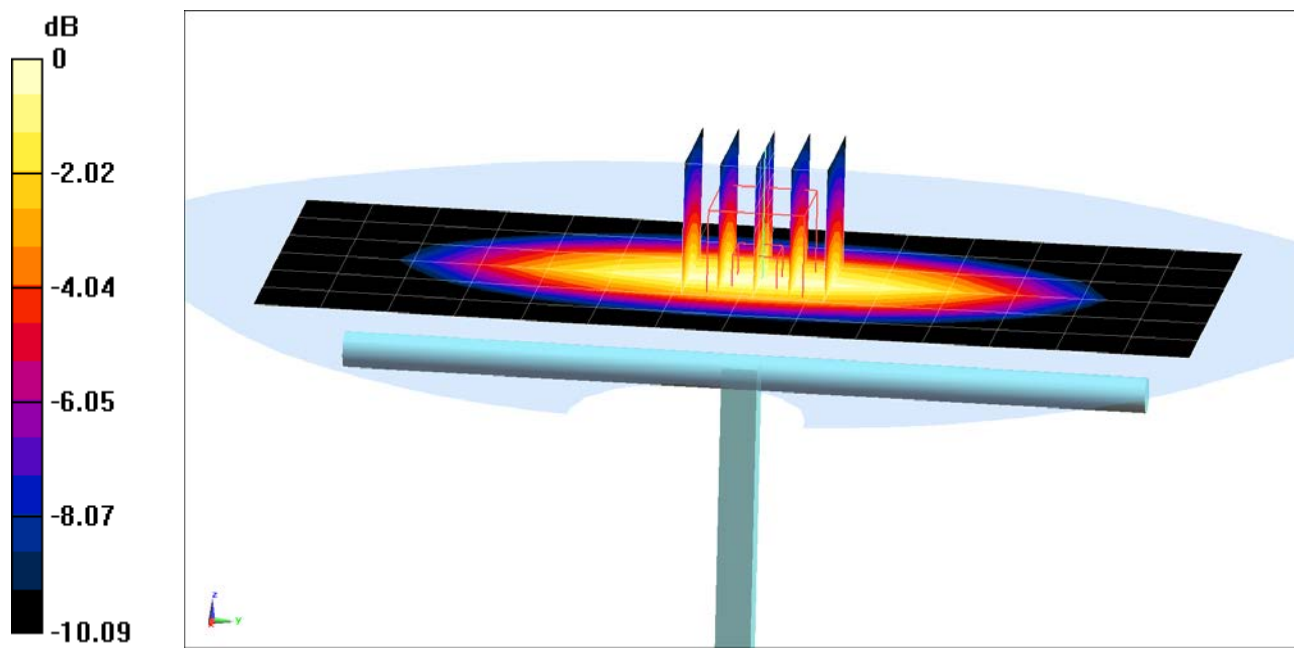

0 dB = 1.06 W/kg = 0.25 dBW/kg

PCTEST ENGINEERING LABORATORY, INC.

DUT: Dipole 835 MHz; Type: D835V2; Serial: 4d132

Communication System: UID 0, CW; Frequency: 835 MHz; Duty Cycle: 1:1
Medium: 835 Body Medium parameters used:
 $f = 835 \text{ MHz}$; $\sigma = 0.961 \text{ S/m}$; $\epsilon_r = 52.937$; $\rho = 1000 \text{ kg/m}^3$
Phantom section: Flat Section; Space: 1.5 cm

Test Date: 03-19-2015; Ambient Temp: 24.4°C; Tissue Temp: 22.0°C

Probe: ES3DV3 - SN3333; ConvF(6.12, 6.12, 6.12); Calibrated: 10/24/2014;
Sensor-Surface: 3mm (Mechanical Surface Detection)
Electronics: DAE4 Sn1408; Calibrated: 10/23/2014
Phantom: Sub TWIN SAM; Type: QD000P40CC; Serial: TP-1357
Measurement SW: DASY52, Version 52.8 (8); SEMCAD X Version 14.6.10 (7331)

835 MHz System Verification

Area Scan (7x14x1): Measurement grid: $dx=15\text{mm}$, $dy=15\text{mm}$

Zoom Scan (5x5x7)/Cube 0: Measurement grid: $dx=8\text{mm}$, $dy=8\text{mm}$, $dz=5\text{mm}$

Input Power = 20 dBm (100 mW)

Peak SAR (extrapolated) = 1.39 W/kg

SAR (1 g) = 0.956 W/kg

Deviation = 4.60%

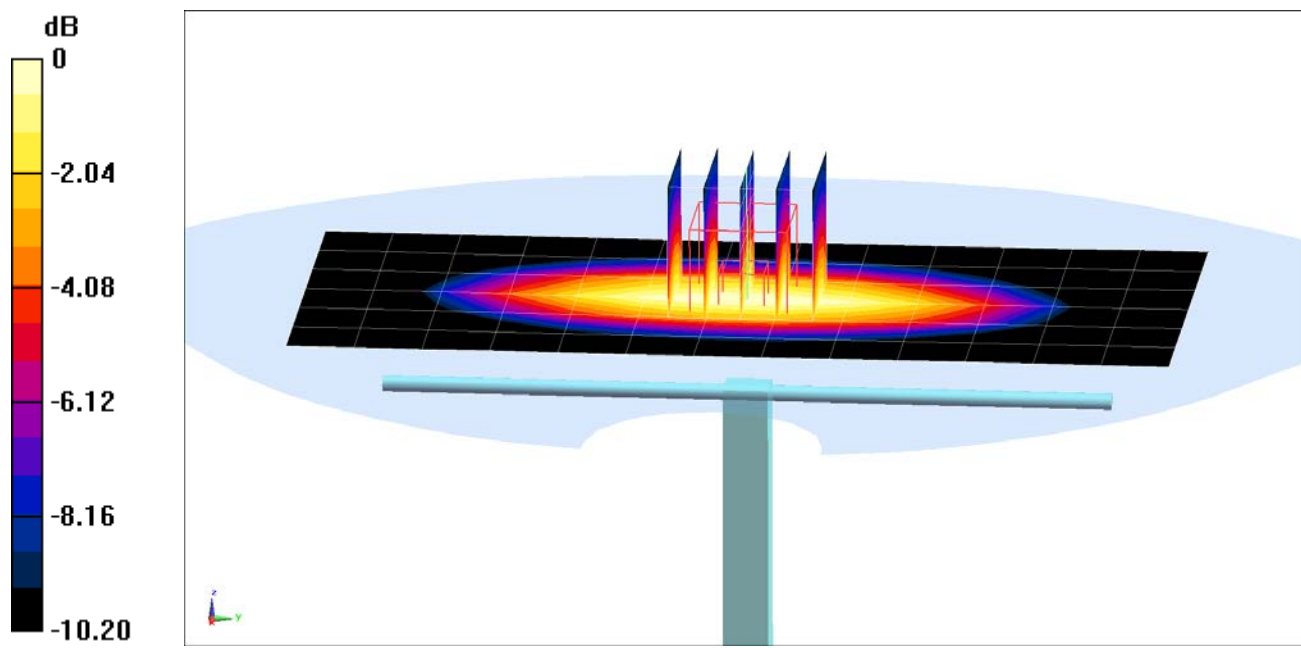

0 dB = 1.12 W/kg = 0.49 dBW/kg

PCTEST ENGINEERING LABORATORY, INC.

DUT: Dipole 1750 MHz; Type: D1750V2; Serial: 1051

Communication System: UID 0, CW; Frequency: 1750 MHz; Duty Cycle: 1:1

Medium: 1750 Body Medium parameters used:

$f = 1750 \text{ MHz}$; $\sigma = 1.518 \text{ S/m}$; $\epsilon_r = 52.874$; $\rho = 1000 \text{ kg/m}^3$

Phantom section: Flat Section; Space: 1.0 cm

Test Date: 03-25-2015; Ambient Temp: 23.3°C; Tissue Temp: 21.4°C

Probe: ES3DV3 - SN3334; ConvF(4.94, 4.94, 4.94); Calibrated: 12/16/2014;

Sensor-Surface: 3mm (Mechanical Surface Detection)

Electronics: DAE4 Sn1415; Calibrated: 12/12/2014

Phantom: ELI v5.0; Type: QDOVA001BB; Serial: 1158

Measurement SW: DASY52, Version 52.8 (8); SEMCAD X Version 14.6.10 (7331)

1750 MHz System Verification

Area Scan (7x9x1): Measurement grid: dx=15mm, dy=15mm

Zoom Scan (5x5x7)/Cube 0: Measurement grid: dx=8mm, dy=8mm, dz=5mm

Input Power = 20 dBm (100 mW)

Peak SAR (extrapolated) = 6.30 W/kg

SAR (1 g) = 3.63 W/kg

Deviation = -2.94%

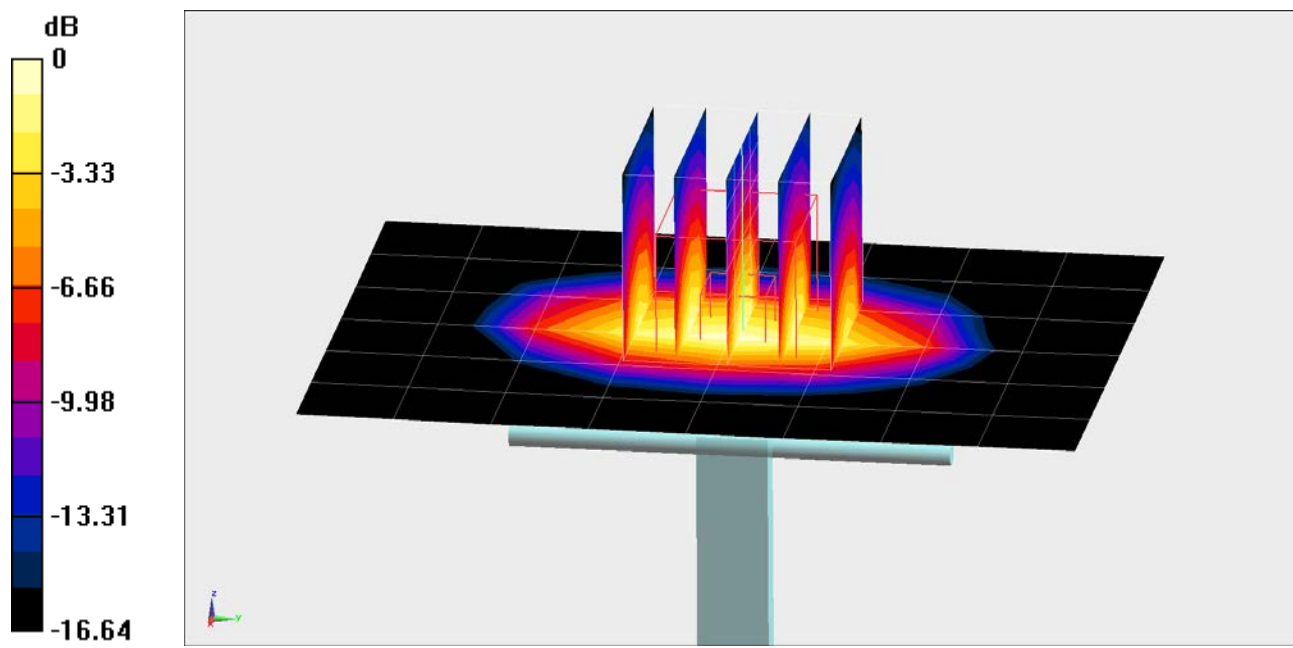

0 dB = 4.54 W/kg = 6.57 dBW/kg

PCTEST ENGINEERING LABORATORY, INC.

DUT: Dipole 1900 MHz; Type: D1900V2; Serial: 5d141

Communication System: UID 0, CW; Frequency: 1900 MHz; Duty Cycle: 1:1
Medium: 1900 Body Medium parameters used (interpolated):
 $f = 1900 \text{ MHz}$; $\sigma = 1.562 \text{ S/m}$; $\epsilon_r = 51.867$; $\rho = 1000 \text{ kg/m}^3$
Phantom section: Flat Section; Space: 1.0 cm

Test Date: 03-23-2015; Ambient Temp: 23.3°C; Tissue Temp: 21.7°C

Probe: ES3DV2 - SN3022; ConvF(4.49, 4.49, 4.49); Calibrated: 8/19/2014;
Sensor-Surface: 3mm (Mechanical Surface Detection)
Electronics: DAE4 Sn1322; Calibrated: 8/12/2014
Phantom: ELI v5.0; Type: QDOVA001BB; Serial: 1226
Measurement SW: DASY52, Version 52.8 (8); SEMCAD X Version 14.6.10 (7331)

1900 MHz System Verification

Area Scan (7x10x1): Measurement grid: dx=15mm, dy=15mm

Zoom Scan (5x5x7)/Cube 0: Measurement grid: dx=8mm, dy=8mm, dz=5mm

Input Power = 20 dBm (100 mW)

Peak SAR (extrapolated) = 7.54 W/kg

SAR (1 g) = 4.31 W/kg

Deviation = 6.16%

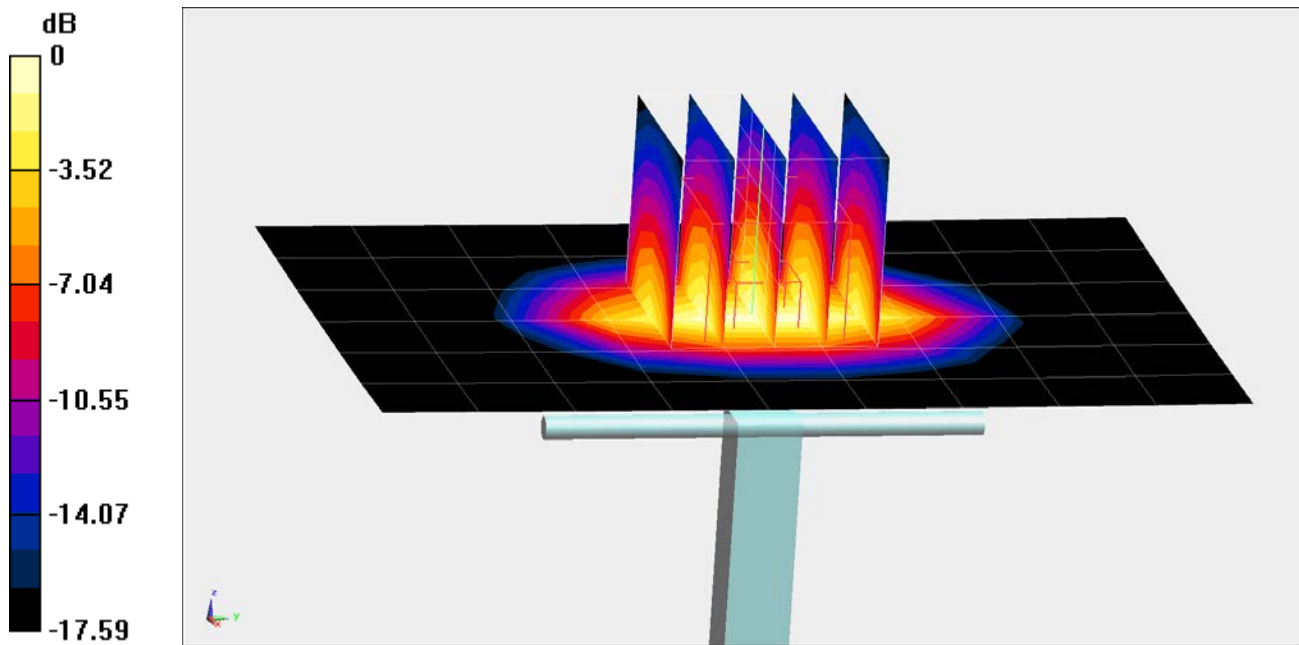

0 dB = 5.45 W/kg = 7.36 dBW/kg

PCTEST ENGINEERING LABORATORY, INC.

DUT: Dipole 2450 MHz; Type: D2450V2; Serial: 719

Communication System: UID 0, CW; Frequency: 2450 MHz; Duty Cycle: 1:1
Medium: 2450 Body Medium parameters used:
 $f = 2450 \text{ MHz}$; $\sigma = 2.028 \text{ S/m}$; $\epsilon_r = 50.797$; $\rho = 1000 \text{ kg/m}^3$
Phantom section: Flat Section; Space: 1.0 cm

Test Date: 03-17-2015; Ambient Temp: 23.1°C; Tissue Temp: 22.4°C

Probe: ES3DV3 - SN3213; ConvF(4.37, 4.37, 4.37); Calibrated: 1/20/2015;
Sensor-Surface: 3mm (Mechanical Surface Detection)
Electronics: DAE4 Sn1407; Calibrated: 1/19/2015
Phantom: SAM Front; Type: SAM; Serial: 1686
Measurement SW: DASY52, Version 52.8 (8); SEMCAD X Version 14.6.10 (7331)

2450 MHz System Verification

Area Scan (8x9x1): Measurement grid: dx=12mm, dy=12mm
Zoom Scan (7x7x7)/Cube 0: Measurement grid: dx=5mm, dy=5mm, dz=5mm
Input Power = 20 dBm (100 mW)
Peak SAR (extrapolated) = 11.5 W/kg
SAR (1 g) = 5.29 W/kg
Deviation = 2.12%

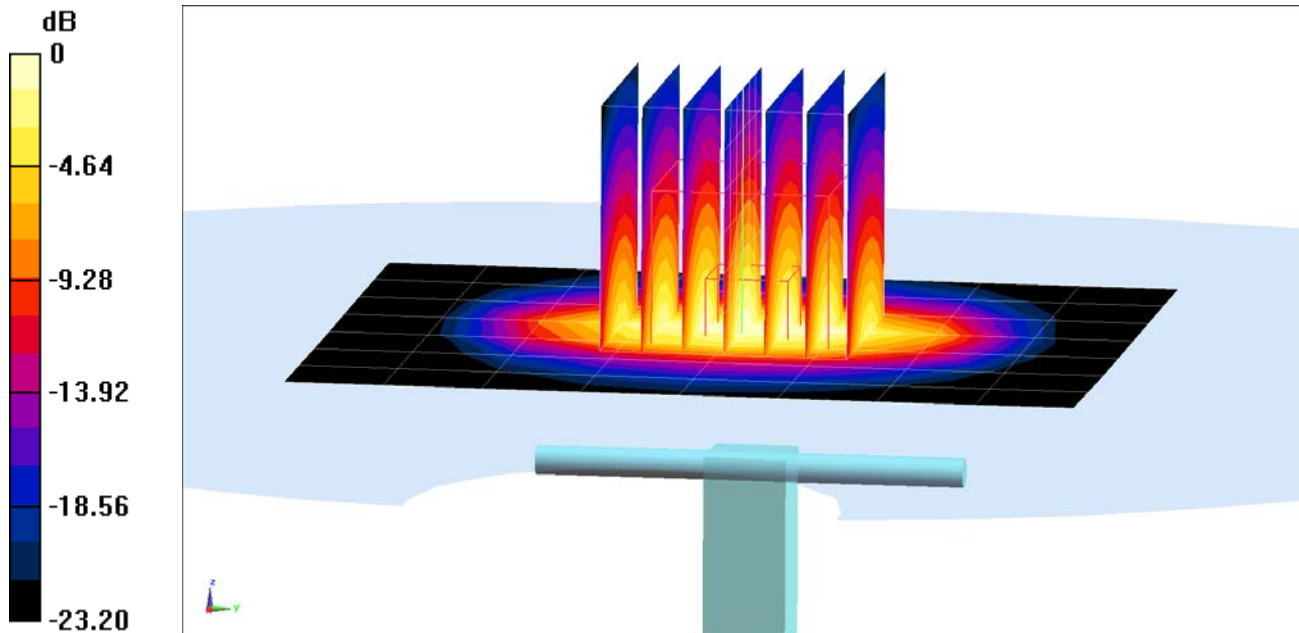

0 dB = 6.74 W/kg = 8.29 dBW/kg

PCTEST ENGINEERING LABORATORY, INC.

DUT: Dipole 2450 MHz; Type: D2450V2; Serial: 719

Communication System: UID 0, CW; Frequency: 2450 MHz; Duty Cycle: 1:1

Medium: 2450 Body Medium parameters used:

$f = 2450$ MHz; $\sigma = 2.041$ S/m; $\epsilon_r = 51.077$; $\rho = 1000$ kg/m³

Phantom section: Flat Section; Space: 1.0 cm

Test Date: 03-25-2015; Ambient Temp: 22.9°C; Tissue Temp: 21.2°C

Probe: ES3DV3 - SN3213; ConvF(4.37, 4.37, 4.37); Calibrated: 1/20/2015;

Sensor-Surface: 3mm (Mechanical Surface Detection)

Electronics: DAE4 Sn1407; Calibrated: 1/19/2015

Phantom: ELI v6.0; Type: QDOVA003AA; Serial: TP:2027

Measurement SW: DASY52, Version 52.8 (8); SEMCAD X Version 14.6.10 (7331)

2450 MHz System Verification

Area Scan (8x9x1): Measurement grid: dx=12mm, dy=12mm

Zoom Scan (7x7x7)/Cube 0: Measurement grid: dx=5mm, dy=5mm, dz=5mm

Input Power = 20 dBm (100 mW)

Peak SAR (extrapolated) = 11.8 W/kg

SAR (1 g) = 5.51 W/kg

Deviation = 6.37%

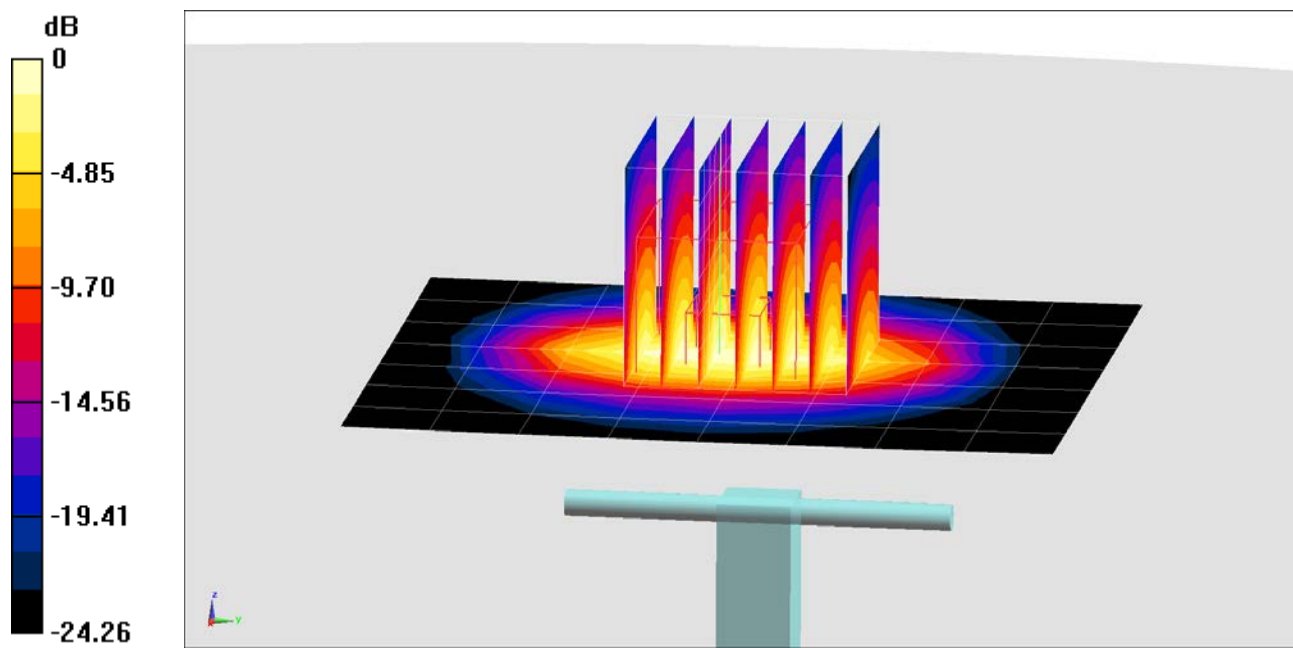

0 dB = 7.23 W/kg = 8.59 dBW/kg

PCTEST ENGINEERING LABORATORY, INC.

DUT: Dipole 2450 MHz; Type: D2450V2; Serial: 882

Communication System: UID 0, CW; Frequency: 2450 MHz; Duty Cycle: 1:1
Medium: 2450 Body Medium parameters used:
 $f = 2450 \text{ MHz}$; $\sigma = 2.041 \text{ S/m}$; $\epsilon_r = 50.778$; $\rho = 1000 \text{ kg/m}^3$
Phantom section: Flat Section; Space: 1.0 cm

Test Date: 04-20-2015; Ambient Temp: 23.4°C; Tissue Temp: 22.5°C

Probe: ES3DV3 - SN3334; ConvF(4.28, 4.28, 4.28); Calibrated: 12/16/2014;
Sensor-Surface: 3mm (Mechanical Surface Detection)
Electronics: DAE4 Sn1415; Calibrated: 12/12/2014
Phantom: Sub Twin Sam v5.0; Type: QD000P40CD; Serial: TP:1626
Measurement SW: DASY52, Version 52.8 (8); SEMCAD X Version 14.6.10 (7331)

2450 MHz System Verification

Area Scan (8x9x1): Measurement grid: dx=12mm, dy=12mm

Zoom Scan (7x7x7)/Cube 0: Measurement grid: dx=5mm, dy=5mm, dz=5mm

Input Power = 20 dBm (100 mW)

Peak SAR (extrapolated) = 11.6 W/kg

SAR (1 g) = 5.44 W/kg; SAR (10 g) = 2.48 W/kg

Deviation (1 g) = 7.30% ; Deviation (10 g) = 5.53%

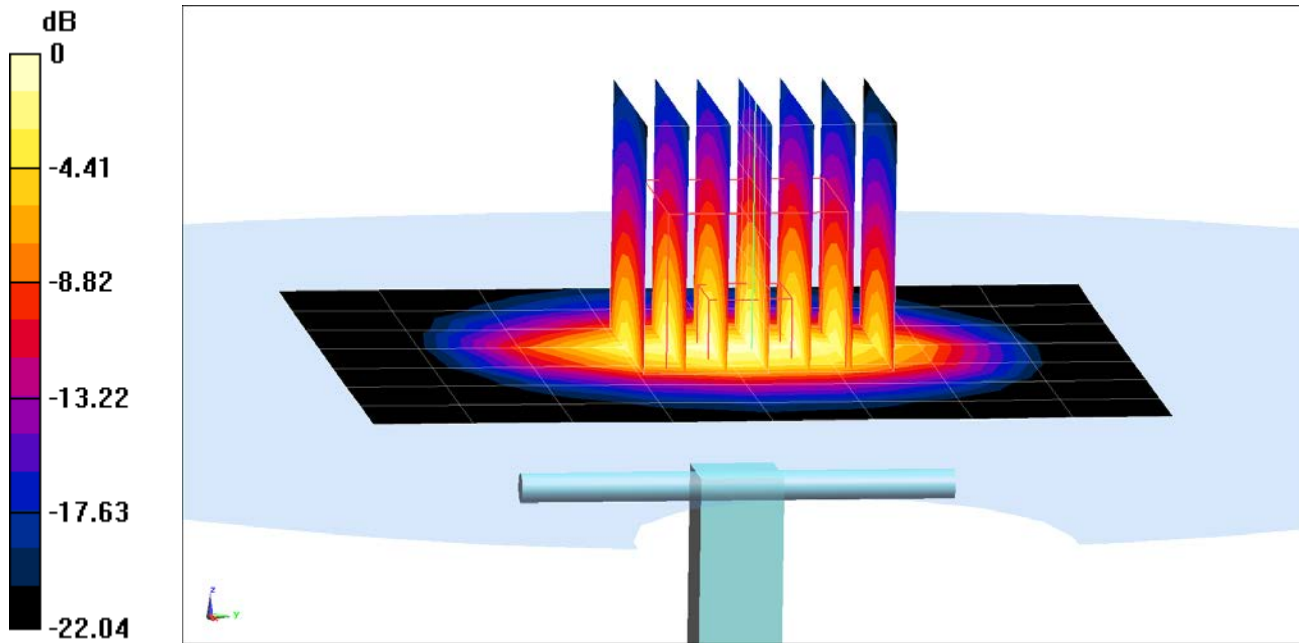

0 dB = 7.18 W/kg = 8.56 dBW/kg

PCTEST ENGINEERING LABORATORY, INC.

DUT: Dipole 5300 MHz; Type: D5GHzV2; Serial: 1191

Communication System: UID 0, CW; Frequency: 5300 MHz; Duty Cycle: 1:1
Medium: 5GHz Body Medium parameters used:
 $f = 5300 \text{ MHz}$; $\sigma = 5.42 \text{ S/m}$; $\epsilon_r = 46.896$; $\rho = 1000 \text{ kg/m}^3$
Phantom section: Flat Section; Space: 1.0 cm

Test Date: 03-31-2015; Ambient Temp: 24.2°C; Tissue Temp: 20.9°C

Probe: EX3DV4 - SN3914; ConvF(4.33, 4.33, 4.33); Calibrated: 2/10/2015;
Sensor-Surface: 1.4mm (Mechanical Surface Detection)
Electronics: DAE4 Sn1333; Calibrated: 10/31/2014
Phantom: SAM Sub; Type: QD000P40CC; Serial: TP:1357
Measurement SW: DASY52, Version 52.8 (8); SEMCAD X Version 14.6.10 (7331)

5300 MHz System Verification

Area Scan (7x8x1): Measurement grid: dx=10mm, dy=10mm

Zoom Scan (8x8x7)/Cube 0: Measurement grid: dx=4mm, dy=4mm, dz=1.4mm; Graded Ratio = 1.4

Input Power = 17 dBm (50 mW)

Peak SAR (extrapolated) = 17.2 W/kg

SAR (1 g) = 3.99 W/kg; SAR (10 g) = 1.10 W/kg

Deviation (1 g) = -0.13 %; Deviation (10 g) = -1.35%

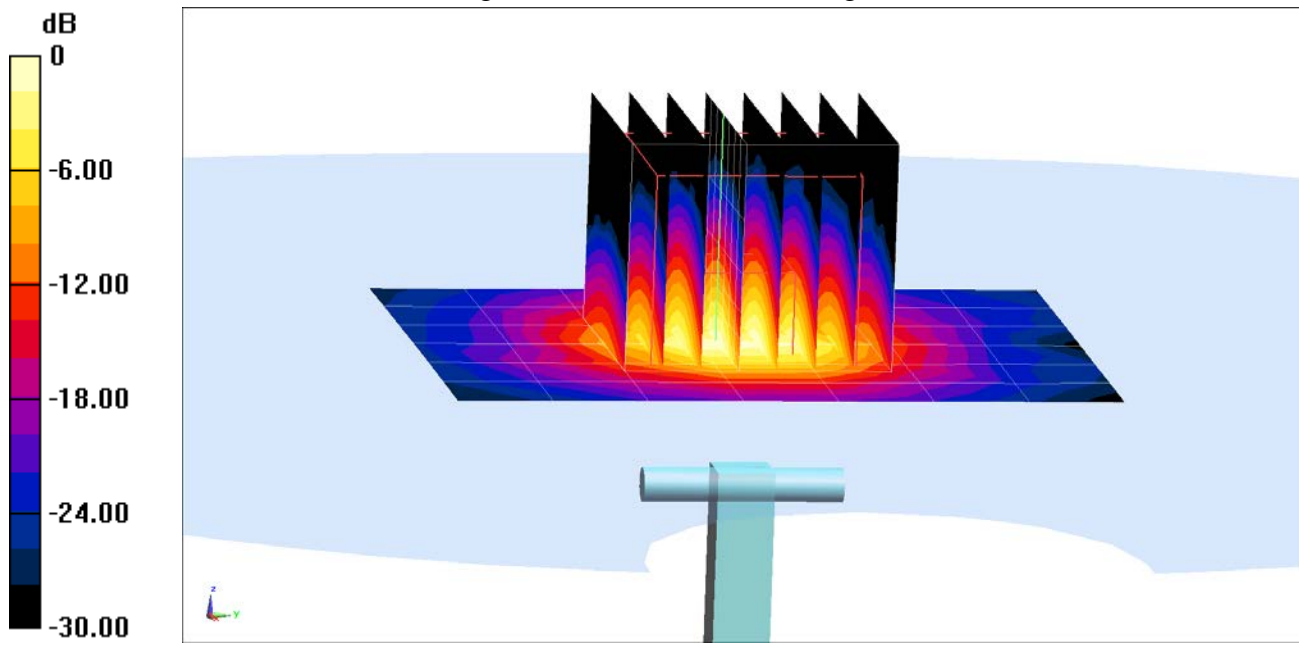

PCTEST ENGINEERING LABORATORY, INC.

DUT: Dipole 5500 MHz; Type: D5GHzV2; Serial: 1191

Communication System: UID 0, CW; Frequency: 5500 MHz; Duty Cycle: 1:1
Medium: 5GHz Body Medium parameters used:
 $f = 5500 \text{ MHz}$; $\sigma = 5.695 \text{ S/m}$; $\epsilon_r = 46.548$; $\rho = 1000 \text{ kg/m}^3$
Phantom section: Flat Section; Space: 1.0 cm

Test Date: 03-31-2015; Ambient Temp: 24.3°C; Tissue Temp: 20.8°C

Probe: EX3DV4 - SN3914; ConvF(3.91, 3.91, 3.91); Calibrated: 2/10/2015;
Sensor-Surface: 1.4mm (Mechanical Surface Detection)
Electronics: DAE4 Sn1333; Calibrated: 10/31/2014
Phantom: SAM Sub; Type: QD000P40CC; Serial: TP:1357
Measurement SW: DASY52, Version 52.8 (8); SEMCAD X Version 14.6.10 (7331)

5500 MHz System Verification

Area Scan (7x7x1): Measurement grid: dx=10mm, dy=10mm

Zoom Scan (8x8x7)/Cube 0: Measurement grid: dx=4mm, dy=4mm, dz=1.4mm; Graded Ratio = 1.4

Input Power = 17 dBm (50 mW)

Peak SAR (extrapolated) = 17.9 W/kg

SAR (1 g) = 4.2 W/kg; SAR (10 g) = 1.16 W/kg

Deviation (1 g) = 1.08%; Deviation (10 g) = 0.87%

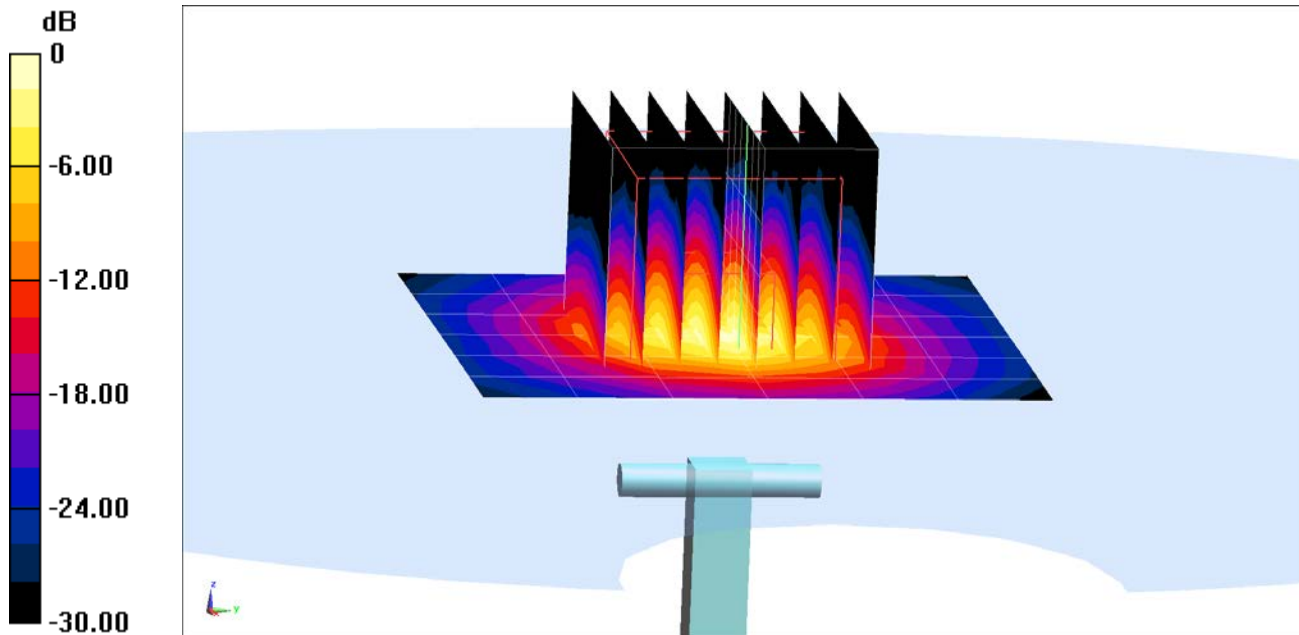

0 dB = 10.1 W/kg = 10.04 dBW/kg

PCTEST ENGINEERING LABORATORY, INC.

DUT: Dipole 5800 MHz; Type: D5GHzV2; Serial: 1191

Communication System: UID 0, CW; Frequency: 5800 MHz; Duty Cycle: 1:1
Medium: 5GHz Body Medium parameters used:
 $f = 5800 \text{ MHz}$; $\sigma = 6.065 \text{ S/m}$; $\epsilon_r = 46.114$; $\rho = 1000 \text{ kg/m}^3$
Phantom section: Flat Section; Space: 1.0 cm

Test Date: 03-31-2015; Ambient Temp: 24.4°C; Tissue Temp: 20.6°C

Probe: EX3DV4 - SN3914; ConvF(4.01, 4.01, 4.01); Calibrated: 2/10/2015;
Sensor-Surface: 1.4mm (Mechanical Surface Detection)
Electronics: DAE4 Sn1333; Calibrated: 10/31/2014
Phantom: SAM Sub; Type: QD000P40CC; Serial: TP:1357
Measurement SW: DASY52, Version 52.8 (8); SEMCAD X Version 14.6.10 (7331)

5800 MHz System Verification

Area Scan (7x7x1): Measurement grid: dx=10mm, dy=10mm

Zoom Scan (8x8x7)/Cube 0: Measurement grid: dx=4mm, dy=4mm, dz=1.4mm; Graded Ratio = 1.4

Input Power = 17 dBm (50 mW)

Peak SAR (extrapolated) = 17.2 W/kg

SAR (1 g) = 3.82 W/kg

Deviation = -2.05%

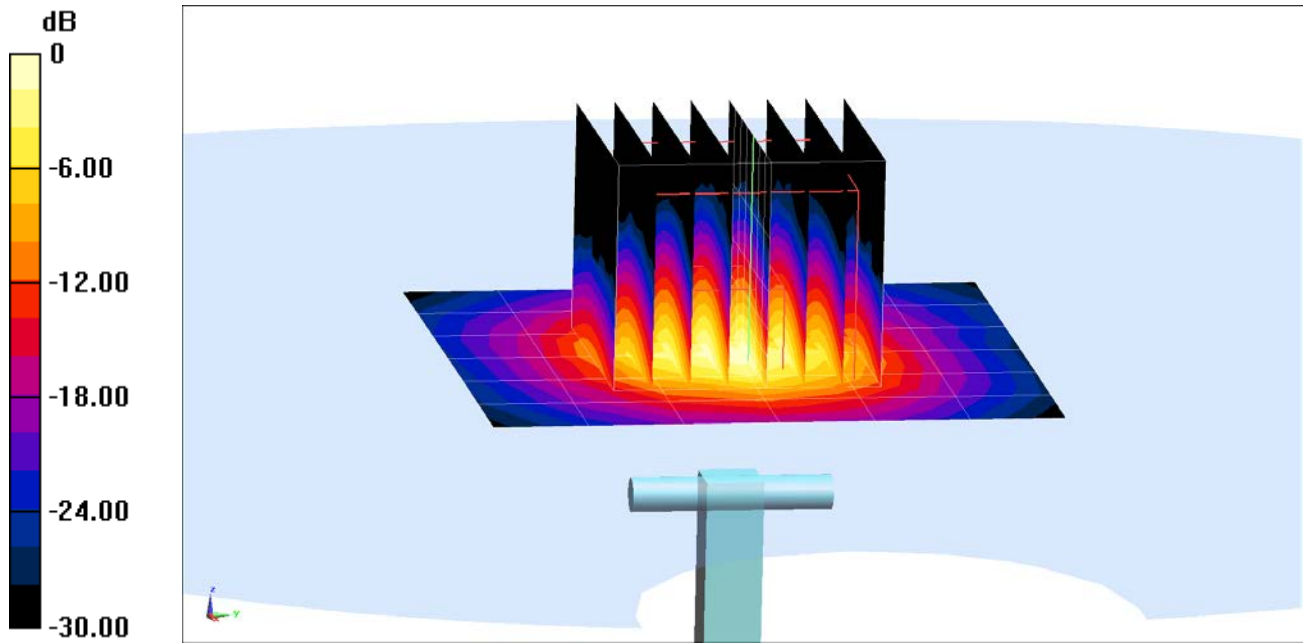

0 dB = 9.49 W/kg = 9.77 dBW/kg

APPENDIX C: PROBE CALIBRATION



Accreditation No.: SCS 0108

Accredited by the Swiss Accreditation Service (SAS)
The Swiss Accreditation Service is one of the signatories to the EA
Multilateral Agreement for the recognition of calibration certificates

Certificate No: D750V3-1003_Jan15

Client **PC Test**

CALIBRATION CERTIFICATE

Object D750V3 - SN: 1003

Calibration procedure(s) QA CAL-05.v9
Calibration procedure for dipole validation kits above 700 MHz

CC
2/3/15

Calibration date: January 16, 2015

This calibration certificate documents the traceability to national standards, which realize the physical units of measurements (SI).
The measurements and the uncertainties with confidence probability are given on the following pages and are part of the certificate.

All calibrations have been conducted in the closed laboratory facility: environment temperature $(22 \pm 3)^\circ\text{C}$ and humidity $< 70\%$.

Calibration Equipment used (M&TE critical for calibration)

Primary Standards	ID #	Cal Date (Certificate No.)	Scheduled Calibration
Power meter EPM-442A	GB37480704	07-Oct-14 (No. 217-02020)	Oct-15
Power sensor HP 8481A	US37292783	07-Oct-14 (No. 217-02020)	Oct-15
Power sensor HP 8481A	MY41092317	07-Oct-14 (No. 217-02021)	Oct-15
Reference 20 dB Attenuator	SN: 5058 (20k)	03-Apr-14 (No. 217-01918)	Apr-15
Type-N mismatch combination	SN: 5047.2 / 06327	03-Apr-14 (No. 217-01921)	Apr-15
Reference Probe ES3DV3	SN: 3205	30-Dec-14 (No. ES3-3205_Dec14)	Dec-15
DAE4	SN: 601	18-Aug-14 (No. DAE4-601_Aug14)	Aug-15
Secondary Standards	ID #	Check Date (in house)	Scheduled Check
RF generator R&S SMT-06	100005	04-Aug-99 (in house check Oct-13)	In house check: Oct-16
Network Analyzer HP 8753E	US37390585 S4206	18-Oct-01 (in house check Oct-14)	In house check: Oct-15

Calibrated by: Name Michael Weber Function Laboratory Technician

Signature

Approved by: Katja Pokovic Technical Manager

Issued: January 19, 2015

This calibration certificate shall not be reproduced except in full without written approval of the laboratory.



Accredited by the Swiss Accreditation Service (SAS)

The Swiss Accreditation Service is one of the signatories to the EA Multilateral Agreement for the recognition of calibration certificates

Glossary:

TSL	tissue simulating liquid
ConvF	sensitivity in TSL / NORM x,y,z
N/A	not applicable or not measured

Calibration is Performed According to the Following Standards:

- IEEE Std 1528-2013, "IEEE Recommended Practice for Determining the Peak Spatial-Averaged Specific Absorption Rate (SAR) in the Human Head from Wireless Communications Devices: Measurement Techniques", June 2013
- IEC 62209-1, "Procedure to measure the Specific Absorption Rate (SAR) for hand-held devices used in close proximity to the ear (frequency range of 300 MHz to 3 GHz)", February 2005
- KDB 865664, "SAR Measurement Requirements for 100 MHz to 6 GHz"

Additional Documentation:

- DASY4/5 System Handbook

Methods Applied and Interpretation of Parameters:

- Measurement Conditions:* Further details are available from the Validation Report at the end of the certificate. All figures stated in the certificate are valid at the frequency indicated.
- Antenna Parameters with TSL:* The dipole is mounted with the spacer to position its feed point exactly below the center marking of the flat phantom section, with the arms oriented parallel to the body axis.
- Feed Point Impedance and Return Loss:* These parameters are measured with the dipole positioned under the liquid filled phantom. The impedance stated is transformed from the measurement at the SMA connector to the feed point. The Return Loss ensures low reflected power. No uncertainty required.
- Electrical Delay:* One-way delay between the SMA connector and the antenna feed point. No uncertainty required.
- SAR measured:* SAR measured at the stated antenna input power.
- SAR normalized:* SAR as measured, normalized to an input power of 1 W at the antenna connector.
- SAR for nominal TSL parameters:* The measured TSL parameters are used to calculate the nominal SAR result.

The reported uncertainty of measurement is stated as the standard uncertainty of measurement multiplied by the coverage factor $k=2$, which for a normal distribution corresponds to a coverage probability of approximately 95%.

Measurement Conditions

DASY system configuration, as far as not given on page 1.

DASY Version	DASY5	V52.8.8
Extrapolation	Advanced Extrapolation	
Phantom	Modular Flat Phantom	
Distance Dipole Center - TSL	15 mm	with Spacer
Zoom Scan Resolution	dx, dy, dz = 5 mm	
Frequency	750 MHz ± 1 MHz	

Head TSL parameters

The following parameters and calculations were applied.

	Temperature	Permittivity	Conductivity
Nominal Head TSL parameters	22.0 °C	41.9	0.89 mho/m
Measured Head TSL parameters	(22.0 ± 0.2) °C	41.7 ± 6 %	0.91 mho/m ± 6 %
Head TSL temperature change during test	< 0.5 °C	----	----

SAR result with Head TSL

SAR averaged over 1 cm³ (1 g) of Head TSL	Condition	
SAR measured	250 mW input power	2.06 W/kg
SAR for nominal Head TSL parameters	normalized to 1W	8.09 W/kg ± 17.0 % (k=2)

SAR averaged over 10 cm³ (10 g) of Head TSL	condition	
SAR measured	250 mW input power	1.35 W/kg
SAR for nominal Head TSL parameters	normalized to 1W	5.32 W/kg ± 16.5 % (k=2)

Body TSL parameters

The following parameters and calculations were applied.

	Temperature	Permittivity	Conductivity
Nominal Body TSL parameters	22.0 °C	55.5	0.96 mho/m
Measured Body TSL parameters	(22.0 ± 0.2) °C	56.0 ± 6 %	0.99 mho/m ± 6 %
Body TSL temperature change during test	< 0.5 °C	----	----

SAR result with Body TSL

SAR averaged over 1 cm³ (1 g) of Body TSL	Condition	
SAR measured	250 mW input power	2.16 W/kg
SAR for nominal Body TSL parameters	normalized to 1W	8.46 W/kg ± 17.0 % (k=2)

SAR averaged over 10 cm³ (10 g) of Body TSL	condition	
SAR measured	250 mW input power	1.42 W/kg
SAR for nominal Body TSL parameters	normalized to 1W	5.58 W/kg ± 16.5 % (k=2)

Appendix (Additional assessments outside the scope of SCS0108)

Antenna Parameters with Head TSL

Impedance, transformed to feed point	53.7 Ω - 1.4 j Ω
Return Loss	- 28.5 dB

Antenna Parameters with Body TSL

Impedance, transformed to feed point	48.3 Ω - 3.8 j Ω
Return Loss	- 27.5 dB

General Antenna Parameters and Design

Electrical Delay (one direction)	1.043 ns
----------------------------------	----------

After long term use with 100W radiated power, only a slight warming of the dipole near the feedpoint can be measured.

The dipole is made of standard semirigid coaxial cable. The center conductor of the feeding line is directly connected to the second arm of the dipole. The antenna is therefore short-circuited for DC-signals. On some of the dipoles, small end caps are added to the dipole arms in order to improve matching when loaded according to the position as explained in the "Measurement Conditions" paragraph. The SAR data are not affected by this change. The overall dipole length is still according to the Standard.

No excessive force must be applied to the dipole arms, because they might bend or the soldered connections near the feedpoint may be damaged.

Additional EUT Data

Manufactured by	SPEAG
Manufactured on	January 21, 2009

DASY5 Validation Report for Head TSL

Date: 16.01.2015

Test Laboratory: SPEAG, Zurich, Switzerland

DUT: Dipole 750 MHz; Type: D750V3; Serial: D750V3 - SN: 1003

Communication System: UID 0 - CW; Frequency: 750 MHz

Medium parameters used: $f = 750$ MHz; $\sigma = 0.91$ S/m; $\epsilon_r = 41.7$; $\rho = 1000$ kg/m³

Phantom section: Flat Section

Measurement Standard: DASY5 (IEEE/IEC/ANSI C63.19-2011)

DASY52 Configuration:

- Probe: ES3DV3 - SN3205; ConvF(6.44, 6.44, 6.44); Calibrated: 30.12.2014;
- Sensor-Surface: 3mm (Mechanical Surface Detection)
- Electronics: DAE4 Sn601; Calibrated: 18.08.2014
- Phantom: Flat Phantom 4.9L; Type: QD000P49AA; Serial: 1001
- DASY52 52.8.8(1222); SEMCAD X 14.6.10(7331)

Dipole Calibration for Head Tissue/Pin=250 mW, d=15mm/Zoom Scan (7x7x7)/Cube 0:

Measurement grid: dx=5mm, dy=5mm, dz=5mm

Reference Value = 53.08 V/m; Power Drift = 0.00 dB

Peak SAR (extrapolated) = 3.05 W/kg

SAR(1 g) = 2.06 W/kg; SAR(10 g) = 1.35 W/kg

Maximum value of SAR (measured) = 2.41 W/kg

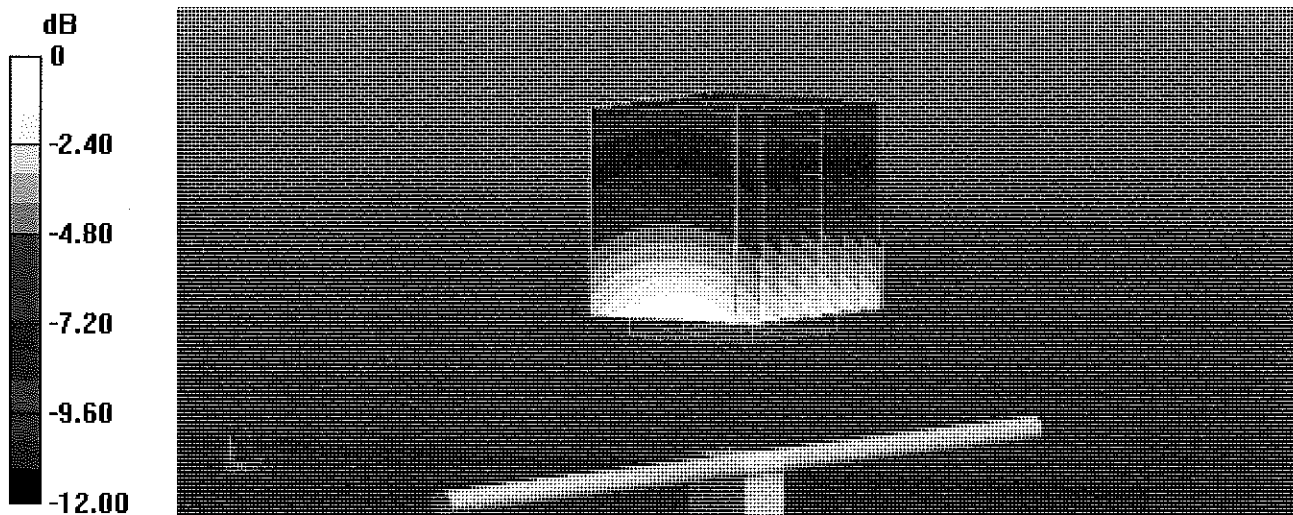

0 dB = 2.41 W/kg = 3.82 dBW/kg

Impedance Measurement Plot for Head TSL

16 Jan 2015 16:07:22

CH1 S11 1 U FS 1: 53.666 Ω -1.3730 Δ 154.55 pF 750.000 000 MHz

*
De1
Ca
Avg
16
H1d

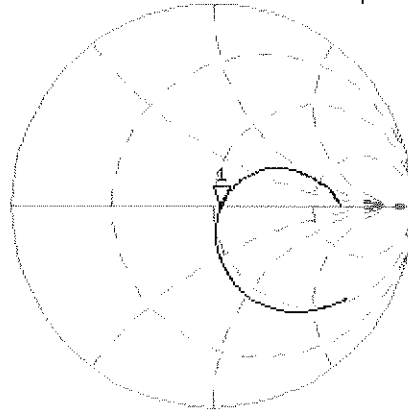

CH2 S11 LOG 5 dB/REF -20 dB 1:-28.456 dB 750.000 000 MHz

Ca
Avg
16
H1d

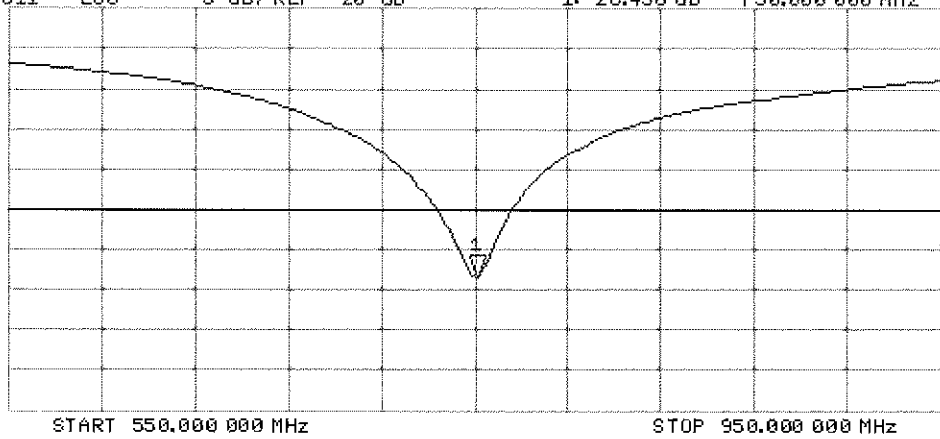

DASY5 Validation Report for Body TSL

Date: 16.01.2015

Test Laboratory: SPEAG, Zurich, Switzerland

DUT: Dipole 750 MHz; Type: D750V3; Serial: D750V3 - SN: 1003

Communication System: UID 0 - CW; Frequency: 750 MHz

Medium parameters used: $f = 750 \text{ MHz}$; $\sigma = 0.99 \text{ S/m}$; $\epsilon_r = 56$; $\rho = 1000 \text{ kg/m}^3$

Phantom section: Flat Section

Measurement Standard: DASY5 (IEEE/IEC/ANSI C63.19-2011)

DASY52 Configuration:

- Probe: ES3DV3 - SN3205; ConvF(6.21, 6.21, 6.21); Calibrated: 30.12.2014;
- Sensor-Surface: 3mm (Mechanical Surface Detection)
- Electronics: DAE4 Sn601; Calibrated: 18.08.2014
- Phantom: Flat Phantom 4.9L; Type: QD000P49AA; Serial: 1001
- DASY52 52.8.8(1222); SEMCAD X 14.6.10(7331)

Dipole Calibration for Body Tissue/Pin=250 mW, d=15mm/Zoom Scan (7x7x7)/Cube 0:

Measurement grid: dx=5mm, dy=5mm, dz=5mm

Reference Value = 52.21 V/m; Power Drift = -0.00 dB

Peak SAR (extrapolated) = 3.16 W/kg

SAR(1 g) = 2.16 W/kg; SAR(10 g) = 1.42 W/kg

Maximum value of SAR (measured) = 2.52 W/kg

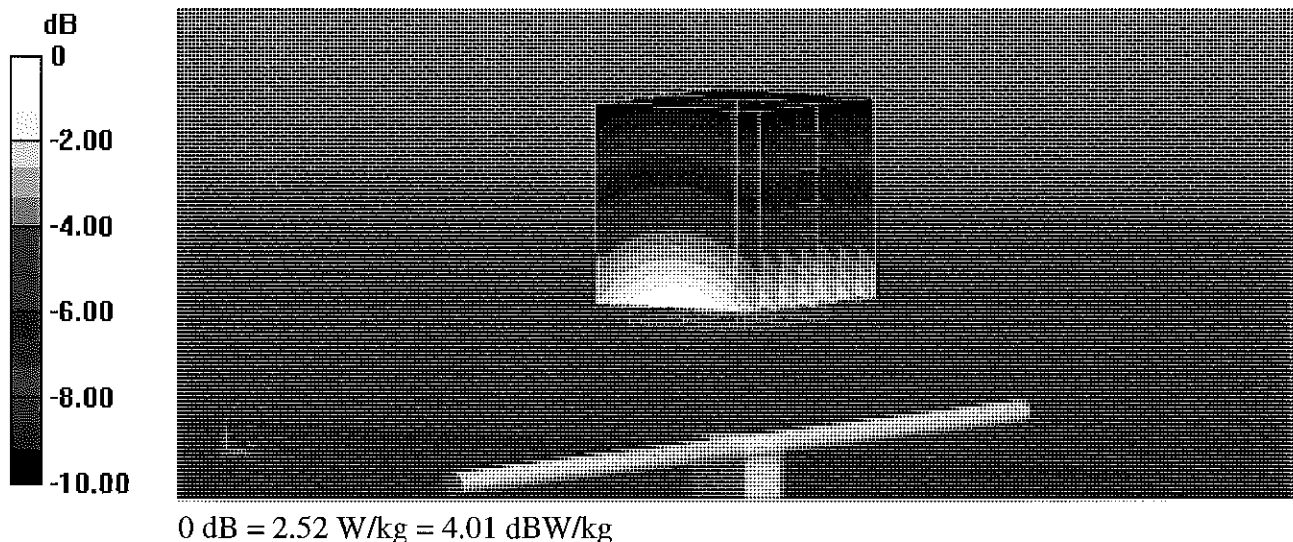

Impedance Measurement Plot for Body TSL

16 Jan 2015 13:37:35

[CH1] S11 1 U FS 1: 48.268 Ω -3.7676 Ω 56.324 pF 750.000 000 MHz

*
De1
CA

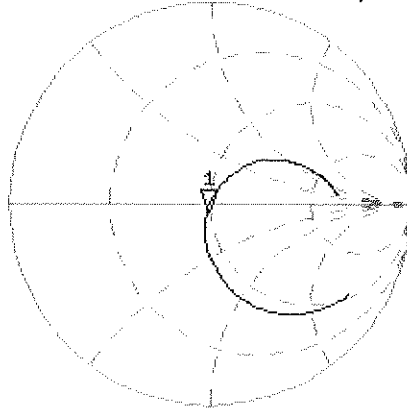

Avg
16

H1d

CH2 S11 LOG 5 dB/REF -20 dB 1:-27.498 dB 750.000 000 MHz

CA

Avg
16

H1d

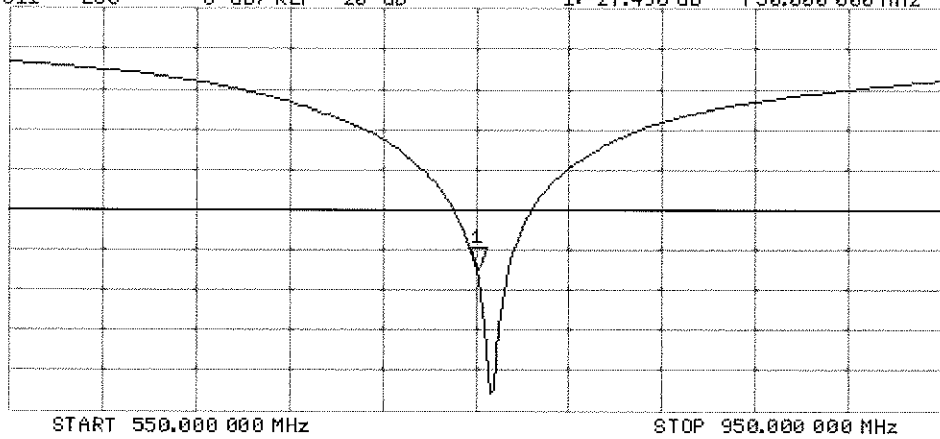

**Calibration Laboratory of
Schmid & Partner
Engineering AG**
Zeughausstrasse 43, 8004 Zurich, Switzerland



S Schweizerischer Kalibrierdienst
S Service suisse d'étalonnage
C Servizio svizzero di taratura
S Swiss Calibration Service

Accredited by the Swiss Accreditation Service (SAS)
The Swiss Accreditation Service is one of the signatories to the EA
Multilateral Agreement for the recognition of calibration certificates

Accreditation No.: **SCS 108**

Client **PC Test**

Certificate No: **D835V2-4d133_Jul14**

CALIBRATION CERTIFICATE

Object **D835V2 - SN: 4d133**

Calibration procedure(s) **QA CAL-05.v9
Calibration procedure for dipole validation kits above 700 MHz**

CC
W/G/M

Calibration date: **July 24, 2014**

This calibration certificate documents the traceability to national standards, which realize the physical units of measurements (SI).
The measurements and the uncertainties with confidence probability are given on the following pages and are part of the certificate.

All calibrations have been conducted in the closed laboratory facility: environment temperature (22 ± 3)°C and humidity < 70%.

Calibration Equipment used (M&TE critical for calibration)

Primary Standards	ID #	Cal Date (Certificate No.)	Scheduled Calibration
Power meter EPM-442A	GB37480704	09-Oct-13 (No. 217-01827)	Oct-14
Power sensor HP 8481A	US37292783	09-Oct-13 (No. 217-01827)	Oct-14
Power sensor HP 8481A	MY41092317	09-Oct-13 (No. 217-01828)	Oct-14
Reference 20 dB Attenuator	SN: 5058 (20k)	03-Apr-14 (No. 217-01918)	Apr-15
Type-N mismatch combination	SN: 5047.2 / 06327	03-Apr-14 (No. 217-01921)	Apr-15
Reference Probe ES3DV3	SN: 3205	30-Dec-13 (No. ES3-3205_Dec13)	Dec-14
DAE4	SN: 601	30-Apr-14 (No. DAE4-601_Apr14)	Apr-15
Secondary Standards	ID #	Check Date (in house)	Scheduled Check
RF generator R&S SMT-06	100005	04-Aug-99 (in house check Oct-13)	In house check: Oct-16
Network Analyzer HP 8763E	US37390585 S4206	18-Oct-01 (in house check Oct-13)	In house check: Oct-14

Calibrated by: **Jeton Kastrali** (Name), **Laboratory Technician** (Function), *[Signature]* (Signature)

Approved by: **Katja Pokovic** (Name), **Technical Manager** (Function), *[Signature]* (Signature)

Issued: July 24, 2014

This calibration certificate shall not be reproduced except in full without written approval of the laboratory.

**Calibration Laboratory of
Schmid & Partner
Engineering AG**
Zeughausstrasse 43, 8004 Zurich, Switzerland



S Schweizerischer Kalibrierdienst
C Service suisse d'étalonnage
S Servizio svizzero di taratura
S Swiss Calibration Service

Accredited by the Swiss Accreditation Service (SAS)
The Swiss Accreditation Service is one of the signatories to the EA
Multilateral Agreement for the recognition of calibration certificates

Accreditation No.: **SCS 108**

Glossary:

TSL	tissue simulating liquid
ConvF	sensitivity in TSL / NORM x,y,z
N/A	not applicable or not measured

Calibration is Performed According to the Following Standards:

- IEEE Std 1528-2013, "IEEE Recommended Practice for Determining the Peak Spatial-Averaged Specific Absorption Rate (SAR) in the Human Head from Wireless Communications Devices: Measurement Techniques", June 2013
- IEC 62209-1, "Procedure to measure the Specific Absorption Rate (SAR) for hand-held devices used in close proximity to the ear (frequency range of 300 MHz to 3 GHz)", February 2005
- KDB 865664, "SAR Measurement Requirements for 100 MHz to 6 GHz"

Additional Documentation:

- DASY4/5 System Handbook

Methods Applied and Interpretation of Parameters:

- Measurement Conditions:* Further details are available from the Validation Report at the end of the certificate. All figures stated in the certificate are valid at the frequency indicated.
- Antenna Parameters with TSL:* The dipole is mounted with the spacer to position its feed point exactly below the center marking of the flat phantom section, with the arms oriented parallel to the body axis.
- Feed Point Impedance and Return Loss:* These parameters are measured with the dipole positioned under the liquid filled phantom. The impedance stated is transformed from the measurement at the SMA connector to the feed point. The Return Loss ensures low reflected power. No uncertainty required.
- Electrical Delay:* One-way delay between the SMA connector and the antenna feed point. No uncertainty required.
- SAR measured:* SAR measured at the stated antenna input power.
- SAR normalized:* SAR as measured, normalized to an input power of 1 W at the antenna connector.
- SAR for nominal TSL parameters:* The measured TSL parameters are used to calculate the nominal SAR result.

The reported uncertainty of measurement is stated as the standard uncertainty of measurement multiplied by the coverage factor $k=2$, which for a normal distribution corresponds to a coverage probability of approximately 95%.

Measurement Conditions

DASY system configuration, as far as not given on page 1.

DASY Version	DASY5	V52.8.8
Extrapolation	Advanced Extrapolation	
Phantom	Modular Flat Phantom	
Distance Dipole Center - TSL	15 mm	with Spacer
Zoom Scan Resolution	dx, dy, dz = 5 mm	
Frequency	835 MHz \pm 1 MHz	

Head TSL parameters

The following parameters and calculations were applied.

	Temperature	Permittivity	Conductivity
Nominal Head TSL parameters	22.0 °C	41.5	0.90 mho/m
Measured Head TSL parameters	(22.0 \pm 0.2) °C	41.1 \pm 6 %	0.94 mho/m \pm 6 %
Head TSL temperature change during test	< 0.5 °C	----	----

SAR result with Head TSL

SAR averaged over 1 cm ³ (1 g) of Head TSL	Condition	
SAR measured	250 mW input power	2.38 W/kg
SAR for nominal Head TSL parameters	normalized to 1W	9.20 W/kg \pm 17.0 % (k=2)

SAR averaged over 10 cm ³ (10 g) of Head TSL	condition	
SAR measured	250 mW input power	1.53 W/kg
SAR for nominal Head TSL parameters	normalized to 1W	5.96 W/kg \pm 16.5 % (k=2)

Body TSL parameters

The following parameters and calculations were applied.

	Temperature	Permittivity	Conductivity
Nominal Body TSL parameters	22.0 °C	55.2	0.97 mho/m
Measured Body TSL parameters	(22.0 \pm 0.2) °C	53.8 \pm 6 %	1.02 mho/m \pm 6 %
Body TSL temperature change during test	< 0.5 °C	----	----

SAR result with Body TSL

SAR averaged over 1 cm ³ (1 g) of Body TSL	Condition	
SAR measured	250 mW input power	2.44 W/kg
SAR for nominal Body TSL parameters	normalized to 1W	9.35 W/kg \pm 17.0 % (k=2)

SAR averaged over 10 cm ³ (10 g) of Body TSL	condition	
SAR measured	250 mW input power	1.59 W/kg
SAR for nominal Body TSL parameters	normalized to 1W	6.15 W/kg \pm 16.5 % (k=2)

Appendix (Additional assessments outside the scope of SCS108)

Antenna Parameters with Head TSL

Impedance, transformed to feed point	51.6 Ω - 1.0 $j\Omega$
Return Loss	- 34.7 dB

Antenna Parameters with Body TSL

Impedance, transformed to feed point	47.8 Ω - 3.3 $j\Omega$
Return Loss	- 27.8 dB

General Antenna Parameters and Design

Electrical Delay (one direction)	1.395 ns
----------------------------------	----------

After long term use with 100W radiated power, only a slight warming of the dipole near the feedpoint can be measured.

The dipole is made of standard semirigid coaxial cable. The center conductor of the feeding line is directly connected to the second arm of the dipole. The antenna is therefore short-circuited for DC-signals. On some of the dipoles, small end caps are added to the dipole arms in order to improve matching when loaded according to the position as explained in the "Measurement Conditions" paragraph. The SAR data are not affected by this change. The overall dipole length is still according to the Standard.

No excessive force must be applied to the dipole arms, because they might bend or the soldered connections near the feedpoint may be damaged.

Additional EUT Data

Manufactured by	SPEAG
Manufactured on	July 22, 2011

DASY5 Validation Report for Head TSL

Date: 24.07.2014

Test Laboratory: SPEAG, Zurich, Switzerland

DUT: Dipole 835 MHz; Type: D835V2; Serial: D835V2 - SN: 4d133

Communication System: UID 0 - CW; Frequency: 835 MHz

Medium parameters used: $f = 835$ MHz; $\sigma = 0.94$ S/m; $\epsilon_r = 41.1$; $\rho = 1000$ kg/m³

Phantom section: Flat Section

Measurement Standard: DASY5 (IEEE/IEC/ANSI C63.19-2011)

DASY52 Configuration:

- Probe: ES3DV3 - SN3205; ConvF(6.22, 6.22, 6.22); Calibrated: 30.12.2013;
- Sensor-Surface: 3mm (Mechanical Surface Detection)
- Electronics: DAE4 Sn601; Calibrated: 30.04.2014
- Phantom: Flat Phantom 4.9L; Type: QD000P49AA; Serial: 1001
- DASY52 52.8.8(1222); SEMCAD X 14.6.10(7331)

Dipole Calibration for Head Tissue/Pin=250 mW, d=15mm/Zoom Scan (7x7x7)/Cube 0:

Measurement grid: dx=5mm, dy=5mm, dz=5mm

Reference Value = 56.07 V/m; Power Drift = 0.03 dB

Peak SAR (extrapolated) = 3.58 W/kg

SAR(1 g) = 2.38 W/kg; SAR(10 g) = 1.53 W/kg

Maximum value of SAR (measured) = 2.79 W/kg

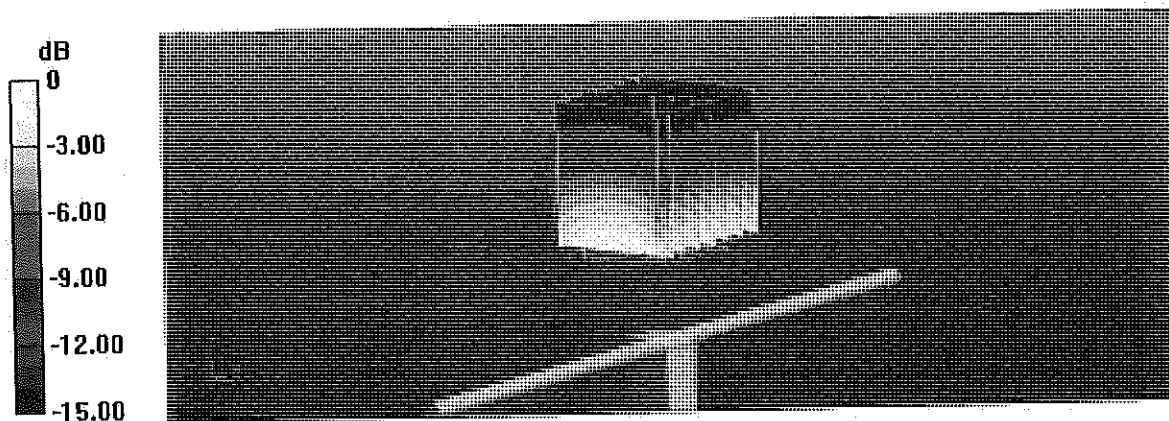

0 dB = 2.79 W/kg = 4.46 dBW/kg

Impedance Measurement Plot for Head TSL

24 Jul 2014 11:33:11

[CHI] S11 1 U F6

Z: 51.553 Ω -1.0293 Ω 105.19 pF 835.000 000 MHz

De1

CA

Avg
16

H1d

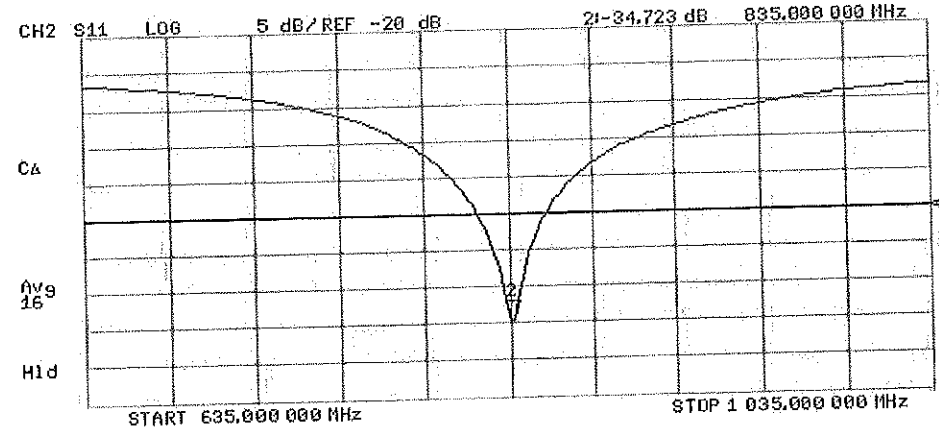
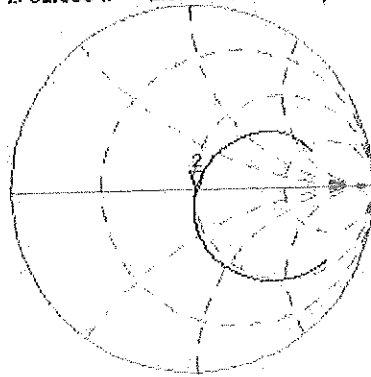

DASY5 Validation Report for Body TSL

Date: 17.07.2014

Test Laboratory: SPEAG, Zurich, Switzerland

DUT: Dipole 835 MHz; Type: D835V2; Serial: D835V2 - SN: 4d133

Communication System: UID 0 - CW; Frequency: 835 MHz
Medium parameters used: $f = 835$ MHz; $\sigma = 1.02$ S/m; $\epsilon_r = 53.8$; $\rho = 1000$ kg/m³
Phantom section: Flat Section
Measurement Standard: DASY5 (IEEE/IEC/ANSI C63.19-2011)

DASY52 Configuration:

- Probe: ES3DV3 - SN3205; ConvF(6.09, 6.09, 6.09); Calibrated: 30.12.2013;
- Sensor-Surface: 3mm (Mechanical Surface Detection)
- Electronics: DAE4 Sn601; Calibrated: 30.04.2014
- Phantom: Flat Phantom 4.9L; Type: QD000P49AA; Serial: 1001
- DASY52 52.8.8(1222); SEMCAD X 14.6.10(7331)

Dipole Calibration for Body Tissue/Pin=250 mW, d=15mm/Zoom Scan (7x7x7)/Cube 0:

Measurement grid: dx=5mm, dy=5mm, dz=5mm
Reference Value = 54.61 V/m; Power Drift = -0.01 dB
Peak SAR (extrapolated) = 3.59 W/kg
SAR(1 g) = 2.44 W/kg; SAR(10 g) = 1.59 W/kg
Maximum value of SAR (measured) = 2.84 W/kg

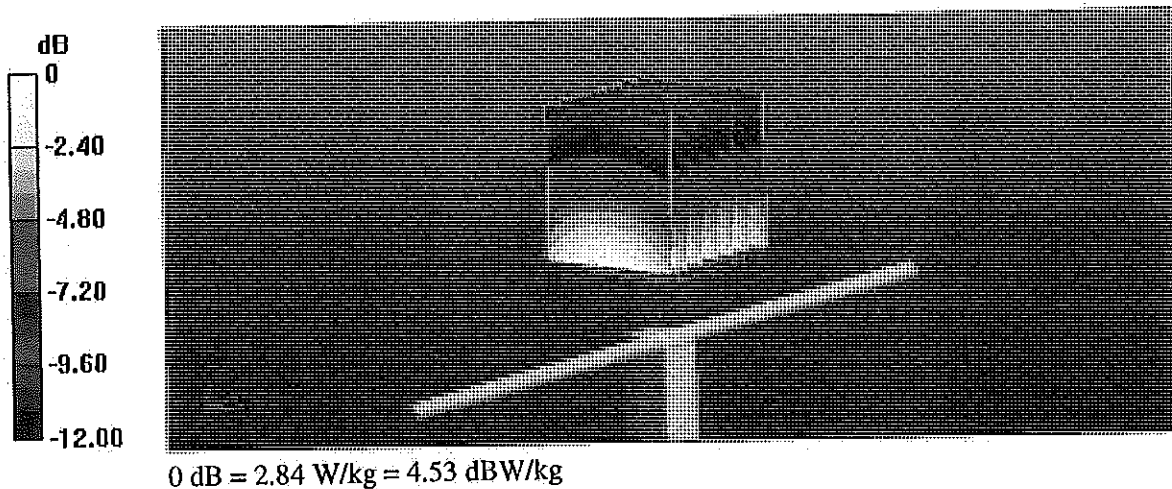

Impedance Measurement Plot for Body TSL

17 Jul 2014 13:43:24

CH1 S11 1 U F8

1: 47.799 Ω -3.3184 Ω 57.439 pF

835.000 000 MHz

*
De1
CA

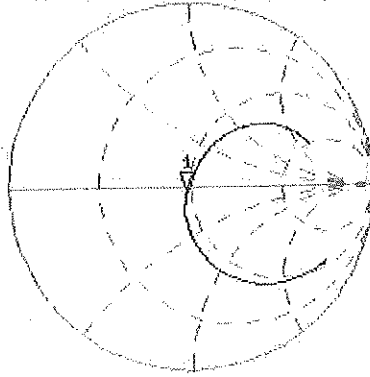

Avg
16

H1d

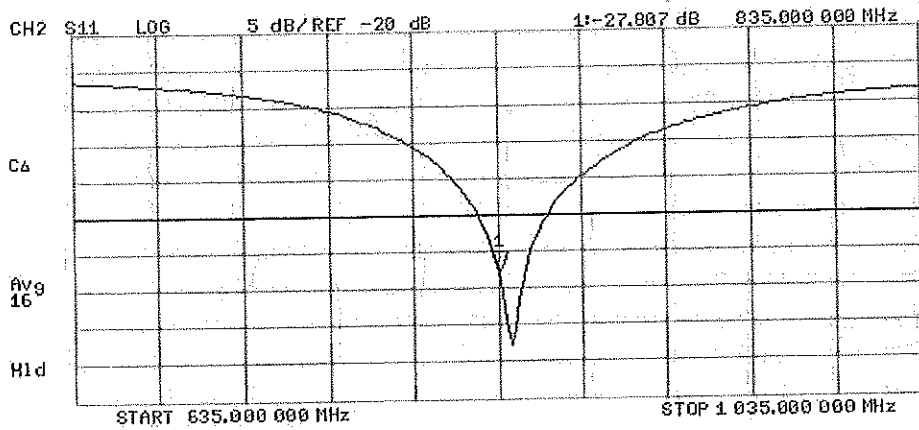

**Calibration Laboratory of
Schmid & Partner
Engineering AG**
Zeughausstrasse 43, 8004 Zurich, Switzerland



S Schweizerischer Kalibrierdienst
C Service suisse d'étalonnage
S Servizio svizzero di taratura
S Swiss Calibration Service

Accredited by the Swiss Accreditation Service (SAS)
The Swiss Accreditation Service is one of the signatories to the EA
Multilateral Agreement for the recognition of calibration certificates

Accreditation No.: **SCS 108**

Client **PC Test**

Certificate No: **D1750V2-1051_Apr14**

CALIBRATION CERTIFICATE

Object **D1750V2 - SN: 1051**

Calibration procedure(s) **QA CAL-05.v9
Calibration procedure for dipole validation kits above 700 MHz**

Calibration date: **April 10, 2014**

*✓
Kok
5/7/14*

This calibration certificate documents the traceability to national standards, which realize the physical units of measurements (SI).
The measurements and the uncertainties with confidence probability are given on the following pages and are part of the certificate.

All calibrations have been conducted in the closed laboratory facility: environment temperature (22 ± 3)°C and humidity < 70%.

Calibration Equipment used (M&TE critical for calibration)

Primary Standards	ID #	Cal Date (Certificate No.)	Scheduled Calibration
Power meter EPM-442A	GB37480704	09-Oct-13 (No. 217-01027)	Oct-14
Power sensor HP 8401A	US37292783	09-Oct-13 (No. 217-01027)	Oct-14
Power sensor HP 8481A	MY41092317	09-Oct-13 (No. 217-01028)	Oct-14
Reference 20 dB Attenuator	SN: 5058 (20k)	03-Apr-14 (No. 217-01018)	Apr-15
Type-N mismatch combination	SN: 5047.2 / 06327	03-Apr-14 (No. 217-01021)	Apr-15
Reference Probe ES3DV3	SN: 3205	30-Dec-13 (No. ES3-3205_Dec13)	Dec-14
DAE4	SN: 601	25-Apr-13 (No. DAE4-601_Apr13)	Apr-14
Secondary Standards	ID #	Check Date (in house)	Scheduled Check
RF generator R&S SMT-06	100005	04-Aug-99 (in house check Oct-13)	In house check: Oct-16
Network Analyzer HP 8753E	US37390585 S4206	18-Oct-01 (in house check Oct-13)	In house check: Oct-14

Calibrated by:	Name Israe El-Naouq	Function Laboratory Technician	Signature <i>Israe El-Naouq</i>
Approved by:	Kalja Pokovic	Technical Manager	<i>Kalja Pokovic</i>

Issued: April 10, 2014

This calibration certificate shall not be reproduced except in full without written approval of the laboratory.



Accredited by the Swiss Accreditation Service (SAS)

The Swiss Accreditation Service is one of the signatories to the EA
Multilateral Agreement for the recognition of calibration certificates

Accreditation No.: **SCS 108**

Glossary:

TSL	tissue simulating liquid
ConvF	sensitivity in TSL / NORM x,y,z
N/A	not applicable or not measured

Calibration is Performed According to the Following Standards:

- IEEE Std 1528-2013, "IEEE Recommended Practice for Determining the Peak Spatial-Averaged Specific Absorption Rate (SAR) in the Human Head from Wireless Communications Devices: Measurement Techniques", June 2013
- IEC 62209-1, "Procedure to measure the Specific Absorption Rate (SAR) for hand-held devices used in close proximity to the ear (frequency range of 300 MHz to 3 GHz)", February 2005
- KDB 865664, "SAR Measurement Requirements for 100 MHz to 6 GHz"

Additional Documentation:

- DASY4/5 System Handbook

Methods Applied and Interpretation of Parameters:

- Measurement Conditions:* Further details are available from the Validation Report at the end of the certificate. All figures stated in the certificate are valid at the frequency indicated.
- Antenna Parameters with TSL:* The dipole is mounted with the spacer to position its feed point exactly below the center marking of the flat phantom section, with the arms oriented parallel to the body axis.
- Feed Point Impedance and Return Loss:* These parameters are measured with the dipole positioned under the liquid filled phantom. The impedance stated is transformed from the measurement at the SMA connector to the feed point. The Return Loss ensures low reflected power. No uncertainty required.
- Electrical Delay:* One-way delay between the SMA connector and the antenna feed point. No uncertainty required.
- SAR measured:* SAR measured at the stated antenna input power.
- SAR normalized:* SAR as measured, normalized to an input power of 1 W at the antenna connector.
- SAR for nominal TSL parameters:* The measured TSL parameters are used to calculate the nominal SAR result.

The reported uncertainty of measurement is stated as the standard uncertainty of measurement multiplied by the coverage factor $k=2$, which for a normal distribution corresponds to a coverage probability of approximately 95%.

Measurement Conditions

DASY system configuration, as far as not given on page 1.

DASY Version	DASY5	V52.8.7
Extrapolation	Advanced Extrapolation	
Phantom	Modular Flat Phantom	
Distance Dipole Center - TSL	10 mm	with Spacer
Zoom Scan Resolution	dx, dy, dz = 5 mm	
Frequency	1750 MHz \pm 1 MHz	

Head TSL parameters

The following parameters and calculations were applied.

	Temperature	Permittivity	Conductivity
Nominal Head TSL parameters	22.0 °C	40.1	1.37 mho/m
Measured Head TSL parameters	(22.0 \pm 0.2) °C	39.1 \pm 6 %	1.35 mho/m \pm 6 %
Head TSL temperature change during test	< 0.5 °C	----	----

SAR result with Head TSL

SAR averaged over 1 cm ³ (1 g) of Head TSL	Condition	
SAR measured	250 mW input power	9.02 W/kg
SAR for nominal Head TSL parameters	normalized to 1W	36.2 W/kg \pm 17.0 % (k=2)

SAR averaged over 10 cm ³ (10 g) of Head TSL	condition	
SAR measured	250 mW input power	4.79 W/kg
SAR for nominal Head TSL parameters	normalized to 1W	19.2 W/kg \pm 16.5 % (k=2)

Body TSL parameters

The following parameters and calculations were applied.

	Temperature	Permittivity	Conductivity
Nominal Body TSL parameters	22.0 °C	53.4	1.49 mho/m
Measured Body TSL parameters	(22.0 \pm 0.2) °C	52.0 \pm 6 %	1.48 mho/m \pm 6 %
Body TSL temperature change during test	< 0.5 °C	----	----

SAR result with Body TSL

SAR averaged over 1 cm ³ (1 g) of Body TSL	Condition	
SAR measured	250 mW input power	9.37 W/kg
SAR for nominal Body TSL parameters	normalized to 1W	37.4 W/kg \pm 17.0 % (k=2)

SAR averaged over 10 cm ³ (10 g) of Body TSL	condition	
SAR measured	250 mW input power	5.04 W/kg
SAR for nominal Body TSL parameters	normalized to 1W	20.1 W/kg \pm 16.5 % (k=2)

Appendix

Antenna Parameters with Head TSL

Impedance, transformed to feed point	$50.7 \Omega + 0.4 j\Omega$
Return Loss	- 41.5 dB

Antenna Parameters with Body TSL

Impedance, transformed to feed point	$46.8 \Omega + 0.8 j\Omega$
Return Loss	- 29,3 dB

General Antenna Parameters and Design

Electrical Delay (one direction)	1.222 ns
----------------------------------	----------

After long term use with 100W radiated power, only a slight warming of the dipole near the feedpoint can be measured.

The dipole is made of standard semirigid coaxial cable. The center conductor of the feeding line is directly connected to the second arm of the dipole. The antenna is therefore short-circuited for DC-signals. On some of the dipoles, small end caps are added to the dipole arms in order to improve matching when loaded according to the position as explained in the "Measurement Conditions" paragraph. The SAR data are not affected by this change. The overall dipole length is still according to the Standard.

No excessive force must be applied to the dipole arms, because they might bend or the soldered connections near the feedpoint may be damaged.

Additional EUT Data

Manufactured by	SPEAG
Manufactured on	February 19, 2010

DASY5 Validation Report for Head TSL

Date: 10.04.2014

Test Laboratory: SPEAG, Zurich, Switzerland

DUT: Dipole 1750 MHz; Type: D1750V2; Serial: D1750V2 - SN: 1051

Communication System: UID 0 - CW; Frequency: 1750 MHz

Medium parameters used: $f = 1750$ MHz; $\sigma = 1.35$ S/m; $\epsilon_r = 39.1$; $\rho = 1000$ kg/m³

Phantom section: Flat Section

Measurement Standard: DASY5 (IEEE/IEC/ANSI C63.19-2007)

DASY52 Configuration:

- Probe: ES3DV3 - SN3205; ConvF(5.23, 5.23, 5.23); Calibrated: 30.12.2013;
- Sensor-Surface: 3mm (Mechanical Surface Detection)
- Electronics: DAE4 Sn601; Calibrated: 25.04.2013
- Phantom: Flat Phantom 5.0 (front); Type: QD000P50AA; Serial: I001
- DASY52 52.8.7(1137); SEMCAD X 14.6.10(7164)

Dipole Calibration for Head Tissue/Pin=250 mW, d=10mm/Zoom Scan (7x7x7)/Cube 0:

Measurement grid: dx=5mm, dy=5mm, dz=5mm

Reference Value = 94.631 V/m; Power Drift = 0.00 dB

Peak SAR (extrapolated) = 16.2 W/kg

SAR(1 g) = 9.02 W/kg; SAR(10 g) = 4.79 W/kg

Maximum value of SAR (measured) = 11.3 W/kg

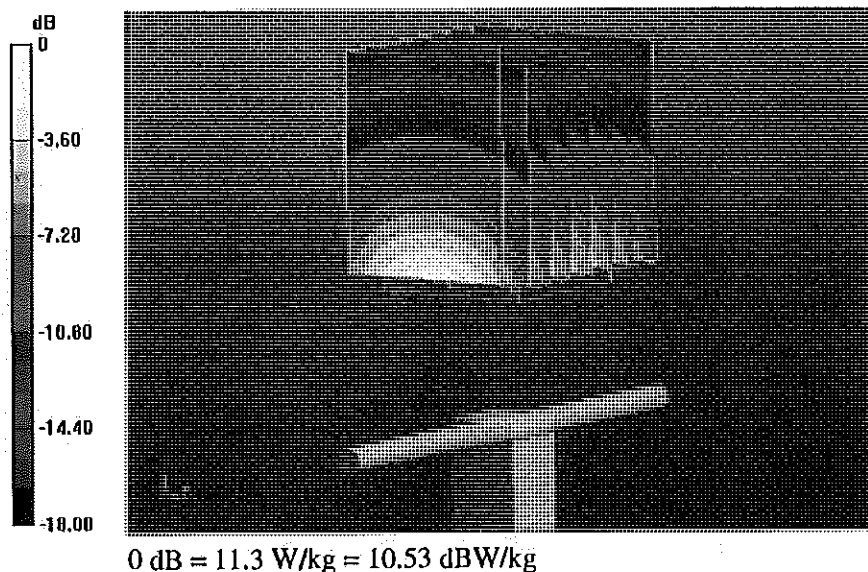

Impedance Measurement Plot for Head TSL

10 Apr 2014 12:21:05

[CH1] S11 1 U FS 1: 50.727 Ω 0.4230 μ 38.545 pF 1 750.000 000 MHz

*
Del
CA
Avg
16
H1d

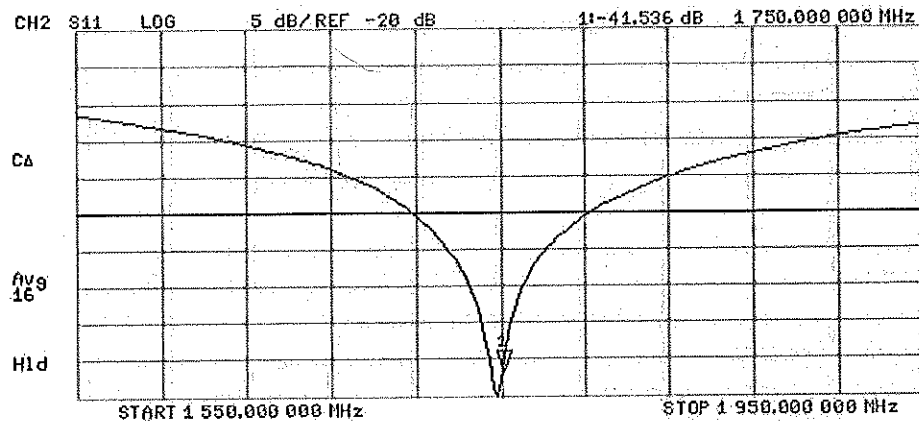
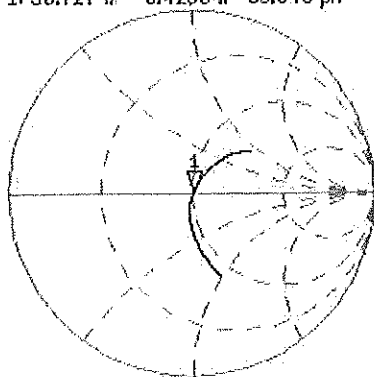

DASY5 Validation Report for Body TSL

Date: 10.04.2014

Test Laboratory: SPEAG, Zurich, Switzerland

DUT: Dipole 1750 MHz; Type: D1750V2; Serial: D1750V2 - SN: 1051

Communication System: UID 0 - CW; Frequency: 1750 MHz

Medium parameters used: $f = 1750$ MHz; $\sigma = 1.48$ S/m; $\epsilon_r = 52$; $\rho = 1000$ kg/m³

Phantom section: Flat Section

Measurement Standard: DASY5 (IEEE/IEC/ANSI C63.19-2007)

DASY52 Configuration:

- Probe: ES3DV3 - SN3205; ConvF(4.89, 4.89, 4.89); Calibrated: 30.12.2013;
- Sensor-Surface: 3mm (Mechanical Surface Detection)
- Electronics: DAE4 Sn601; Calibrated: 25.04.2013
- Phantom: Flat Phantom 5.0 (back); Type: QD000P50AA; Serial: 1002
- DASY52 52.8.7(1137); SEMCAD X 14.6.10(7164)

Dipole Calibration for Body Tissue/Pin=250 mW, d=10mm/Zoom Scan (7x7x7)/Cube 0:

Measurement grid: dx=5mm, dy=5mm, dz=5mm

Reference Value = 93.321 V/m; Power Drift = -0,01 dB

Peak SAR (extrapolated) = 16.1 W/kg

SAR(1 g) = 9.37 W/kg; SAR(10 g) = 5.04 W/kg

Maximum value of SAR (measured) = 11.8 W/kg

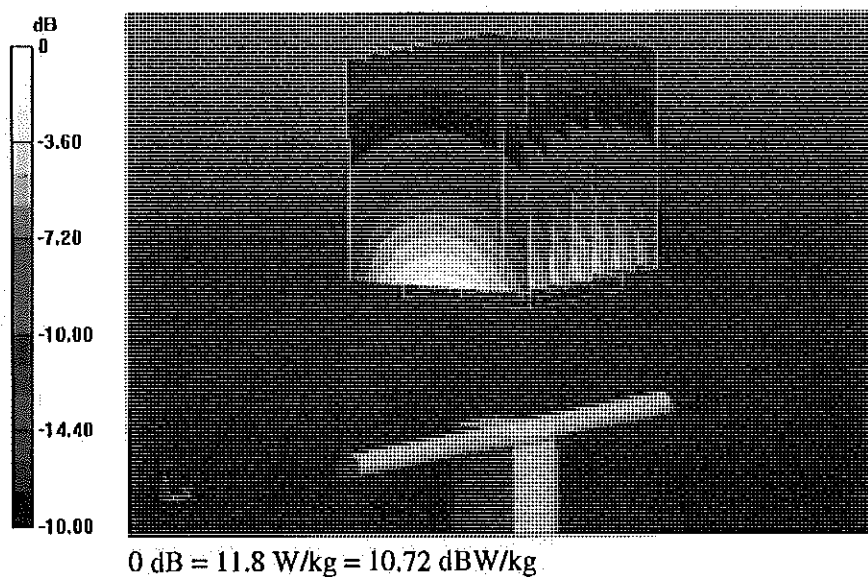

Impedance Measurement Plot for Body TSL

10 Apr 2014 12:20:40

CH1 S11 1 U FS 1: 46.787 Ω 0.8086 Ω 73.538 pH 1 750.000 000 MHz

*
De I
CA

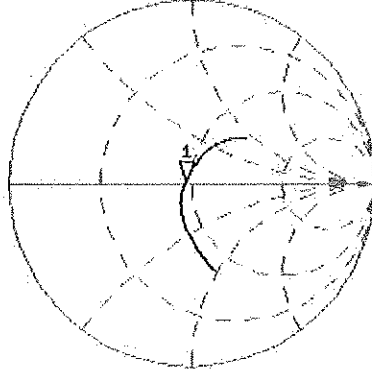

Avg
16

H1 d

CH2 S11 LOG 5 dB/REF -20 dB 1:-29.320 dB 1 750.000 000 MHz

CA

Avg
16

H1 d

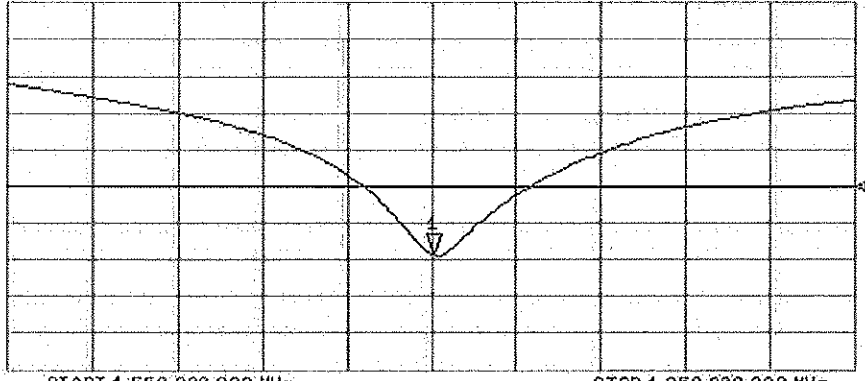



Accredited by the Swiss Accreditation Service (SAS)
The Swiss Accreditation Service is one of the signatories to the EA
Multilateral Agreement for the recognition of calibration certificates

Accreditation No.: **SCS 108**

Client **PC Test**

Certificate No: **D1900V2-5d141_Apr14**

CALIBRATION CERTIFICATE

Object **D1900V2 - SN: 5d141**

Calibration procedure(s) **QA CAL-05.v9
Calibration procedure for dipole validation kits above 700 MHz**

Calibration date: **April 09, 2014**

✓
Kok
5/7/14

This calibration certificate documents the traceability to national standards, which realize the physical units of measurements (SI).
The measurements and the uncertainties with confidence probability are given on the following pages and are part of the certificate.

All calibrations have been conducted in the closed laboratory facility: environment temperature (22 ± 3)°C and humidity < 70%.

Calibration Equipment used (M&TE critical for calibration)

Primary Standards	ID #	Cal Date (Certificate No.)	Scheduled Calibration
Power meter EPM-442A	GB37480704	09-Oct-13 (No. 217-01827)	Oct-14
Power sensor HP 8481A	US37292783	09-Oct-13 (No. 217-01827)	Oct-14
Power sensor HP 8481A	MY41092317	09-Oct-13 (No. 217-01828)	Oct-14
Reference 20 dB Attenuator	SN: 5058 (20k)	03-Apr-14 (No. 217-01918)	Apr-15
Type-N mismatch combination	SN: 5047,2 / 06327	03-Apr-14 (No. 217-01921)	Apr-15
Reference Probe ES3DV3	SN: 3205	30-Dec-13 (No. ES3-3205_Dec13)	Dec-14
DAE4	SN: 801	25-Apr-13 (No. DAE4-801_Apr13)	Apr-14

Secondary Standards	ID #	Check Date (in house)	Scheduled Check
RF generator R&S SMT-06	100005	04-Aug-99 (in house check Oct-13)	In house check: Oct-16
Network Analyzer HP 8753E	US37390585 S4206	18-Oct-01 (in house check Oct-13)	In house check: Oct-14

Calibrated by: **Claudio Leubler** Function: **Laboratory Technician**

Approved by: **Katja Pokovic** Technical Manager

Signature

Issued: April 9, 2014

This calibration certificate shall not be reproduced except in full without written approval of the laboratory.



Accredited by the Swiss Accreditation Service (SAS)
The Swiss Accreditation Service is one of the signatories to the EA
Multilateral Agreement for the recognition of calibration certificates

Accreditation No.: **SCS 108**

Glossary:

TSL	tissue simulating liquid
ConvF	sensitivity in TSL / NORM x,y,z
N/A	not applicable or not measured

Calibration is Performed According to the Following Standards:

- a) IEEE Std 1528-2013, "IEEE Recommended Practice for Determining the Peak Spatial-Averaged Specific Absorption Rate (SAR) in the Human Head from Wireless Communications Devices: Measurement Techniques", June 2013
- b) IEC 62209-1, "Procedure to measure the Specific Absorption Rate (SAR) for hand-held devices used in close proximity to the ear (frequency range of 300 MHz to 3 GHz)", February 2005
- c) KDB 865664, "SAR Measurement Requirements for 100 MHz to 6 GHz"

Additional Documentation:

- d) DASY4/5 System Handbook

Methods Applied and Interpretation of Parameters:

- *Measurement Conditions:* Further details are available from the Validation Report at the end of the certificate. All figures stated in the certificate are valid at the frequency indicated.
- *Antenna Parameters with TSL:* The dipole is mounted with the spacer to position its feed point exactly below the center marking of the flat phantom section, with the arms oriented parallel to the body axis.
- *Feed Point Impedance and Return Loss:* These parameters are measured with the dipole positioned under the liquid filled phantom. The impedance stated is transformed from the measurement at the SMA connector to the feed point. The Return Loss ensures low reflected power. No uncertainty required.
- *Electrical Delay:* One-way delay between the SMA connector and the antenna feed point. No uncertainty required.
- *SAR measured:* SAR measured at the stated antenna input power.
- *SAR normalized:* SAR as measured, normalized to an input power of 1 W at the antenna connector.
- *SAR for nominal TSL parameters:* The measured TSL parameters are used to calculate the nominal SAR result.

The reported uncertainty of measurement is stated as the standard uncertainty of measurement multiplied by the coverage factor $k=2$, which for a normal distribution corresponds to a coverage probability of approximately 95%.

Measurement Conditions

DASY system configuration, as far as not given on page 1.

DASY Version	DASY5	V52.8.7
Extrapolation	Advanced Extrapolation	
Phantom	Modular Flat Phantom	
Distance Dipole Center - TSL	10 mm	with Spacer
Zoom Scan Resolution	dx, dy, dz = 5 mm	
Frequency	1900 MHz \pm 1 MHz	

Head TSL parameters

The following parameters and calculations were applied.

	Temperature	Permittivity	Conductivity
Nominal Head TSL parameters	22.0 °C	40.0	1.40 mho/m
Measured Head TSL parameters	(22.0 \pm 0.2) °C	39.1 \pm 6 %	1.36 mho/m \pm 6 %
Head TSL temperature change during test	< 0.5 °C	----	----

SAR result with Head TSL

SAR averaged over 1 cm ³ (1 g) of Head TSL	Condition	
SAR measured	250 mW input power	9.91 W/kg
SAR for nominal Head TSL parameters	normalized to 1W	40.1 W/kg \pm 17.0 % (k=2)

SAR averaged over 10 cm ³ (10 g) of Head TSL	condition	
SAR measured	250 mW input power	5.17 W/kg
SAR for nominal Head TSL parameters	normalized to 1W	20.8 W/kg \pm 16.5 % (k=2)

Body TSL parameters

The following parameters and calculations were applied.

	Temperature	Permittivity	Conductivity
Nominal Body TSL parameters	22.0 °C	53.3	1.52 mho/m
Measured Body TSL parameters	(22.0 \pm 0.2) °C	52.4 \pm 6 %	1.52 mho/m \pm 6 %
Body TSL temperature change during test	< 0.5 °C	----	----

SAR result with Body TSL

SAR averaged over 1 cm ³ (1 g) of Body TSL	Condition	
SAR measured	250 mW input power	10.2 W/kg
SAR for nominal Body TSL parameters	normalized to 1W	40.6 W/kg \pm 17.0 % (k=2)

SAR averaged over 10 cm ³ (10 g) of Body TSL	condition	
SAR measured	250 mW input power	5.41 W/kg
SAR for nominal Body TSL parameters	normalized to 1W	21.6 W/kg \pm 16.5 % (k=2)

Appendix

Antenna Parameters with Head TSL

Impedance, transformed to feed point	52.8 Ω + 5.5 j Ω
Return Loss	- 24.5 dB

Antenna Parameters with Body TSL

Impedance, transformed to feed point	48.8 Ω + 6.3 j Ω
Return Loss	- 23.7 dB

General Antenna Parameters and Design

Electrical Delay (one direction)	1.199 ns
----------------------------------	----------

After long term use with 100W radiated power, only a slight warming of the dipole near the feedpoint can be measured.

The dipole is made of standard semirigid coaxial cable. The center conductor of the feeding line is directly connected to the second arm of the dipole. The antenna is therefore short-circuited for DC-signals. On some of the dipoles, small end caps are added to the dipole arms in order to improve matching when loaded according to the position as explained in the "Measurement Conditions" paragraph. The SAR data are not affected by this change. The overall dipole length is still according to the Standard.

No excessive force must be applied to the dipole arms, because they might bend or the soldered connections near the feedpoint may be damaged.

Additional EUT Data

Manufactured by	SPEAG
Manufactured on	March 11, 2011

DASY5 Validation Report for Head TSL

Date: 09.04.2014

Test Laboratory: SPEAG, Zurich, Switzerland

DUT: Dipole 1900 MHz; Type: D1900V2; Serial: D1900V2 - SN: 5d141

Communication System: UID 0 - CW; Frequency: 1900 MHz

Medium parameters used: $f = 1900$ MHz; $\sigma = 1.36$ S/m; $\epsilon_r = 39.1$; $\rho = 1000$ kg/m³

Phantom section: Flat Section

Measurement Standard: DASY5 (IEEE/IEC/ANSI C63.19-2007)

DASY52 Configuration:

- Probe: ES3DV3 - SN3205; ConvF(5.06, 5.06, 5.06); Calibrated: 30.12.2013;
- Sensor-Surface: 3mm (Mechanical Surface Detection)
- Electronics: DAE4 Sn601; Calibrated: 25.04.2013
- Phantom: Flat Phantom 5.0 (front); Type: QD000P50AA; Serial: 1001
- DASY52 52.8.7(1137); SEMCAD X 14.6.10(7164)

Dipole Calibration for Head Tissue/ $P_{in}=250$ mW, $d=10$ mm/Zoom Scan (7x7x7)/Cube 0:

Measurement grid: $dx=5$ mm, $dy=5$ mm, $dz=5$ mm

Reference Value = 99.080 V/m; Power Drift = 0.01 dB

Peak SAR (extrapolated) = 18.2 W/kg

SAR(1 g) = 9.91 W/kg; SAR(10 g) = 5.17 W/kg

Maximum value of SAR (measured) = 12.5 W/kg

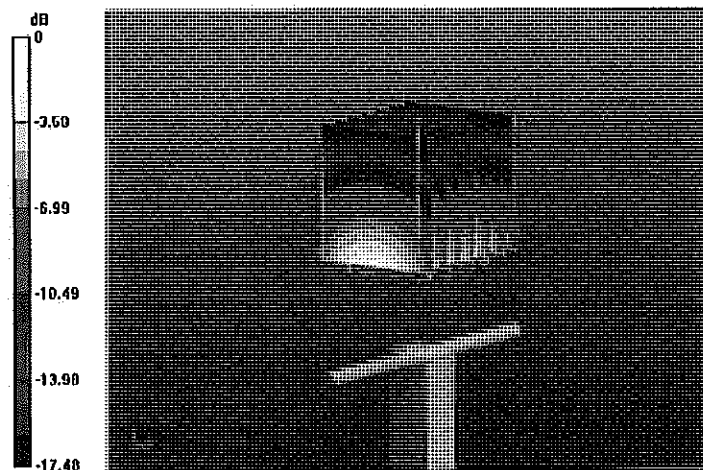

0 dB = 12.5 W/kg = 10.97 dBW/kg

Impedance Measurement Plot for Head TSL

9 Apr 2014 11:03:32

CH1 S11 1 U FS 1: 52.760 n 5.4512 n 456.62 pH 1 900.000 000 MHz

*
Del
CA

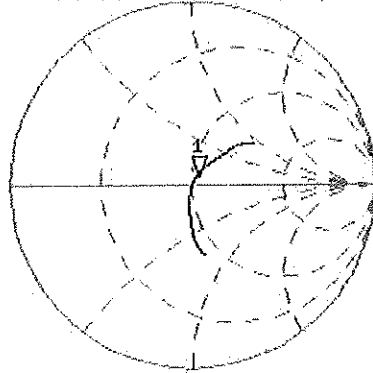

AVG
16

H1d

CH2 S11 LOG 5 dB/REF -20 dB 1: -24.525 dB 1 900.000 000 MHz

CA

AVG
16

H1d

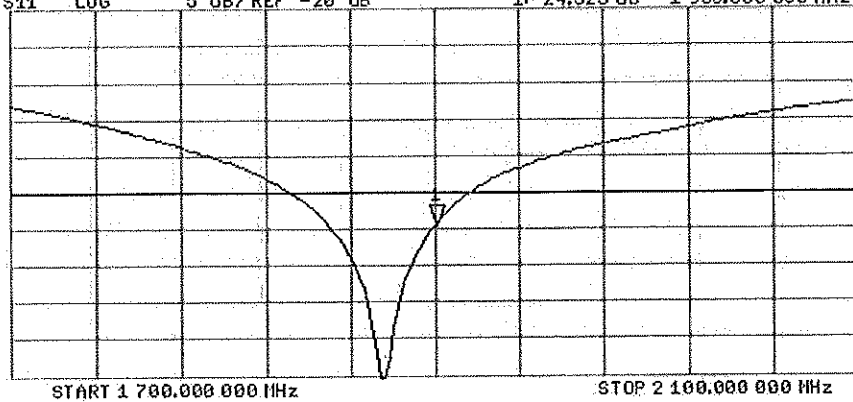

DASY5 Validation Report for Body TSL

Date: 09.04.2014

Test Laboratory: SPEAG, Zurich, Switzerland

DUT: Dipole 1900 MHz; Type: D1900V2; Serial: D1900V2 - SN: 5d141

Communication System: UID 0 - CW; Frequency: 1900 MHz

Medium parameters used: $f = 1900$ MHz; $\sigma = 1.52$ S/m; $\epsilon_r = 52.4$; $\rho = 1000$ kg/m³

Phantom section: Flat Section

Measurement Standard: DASY5 (IEEE/IEC/ANSI C63.19-2007)

DASY52 Configuration:

- Probe: ES3DV3 - SN3205; ConvF(4.76, 4.76, 4.76); Calibrated: 30.12.2013;
- Sensor-Surface: 3mm (Mechanical Surface Detection)
- Electronics: DAE4 Sn601; Calibrated: 25.04.2013
- Phantom: Flat Phantom 5.0 (back); Type: QD000P50AA; Serial: 1002
- DASY52 52.8.7(1137); SEMCAD X 14.6.10(7164)

Dipole Calibration for Body Tissue/Pin=250 mW, d=10mm/Zoom Scan (7x7x7)/Cube 0:

Measurement grid: dx=5mm, dy=5mm, dz=5mm

Reference Value = 95.820 V/m; Power Drift = -0.01 dB

Peak SAR (extrapolated) = 17.9 W/kg

SAR(1 g) = 10.2 W/kg; SAR(10 g) = 5.41 W/kg

Maximum value of SAR (measured) = 12.9 W/kg

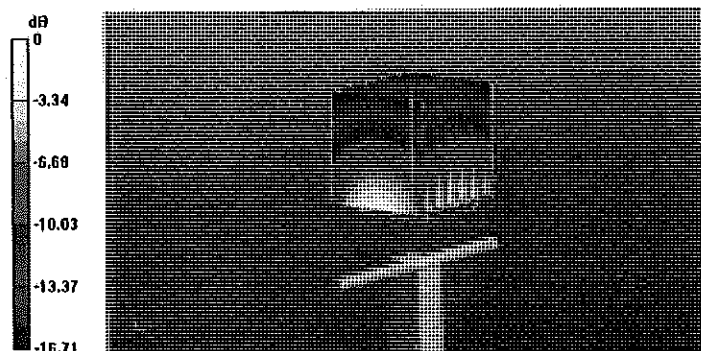

0 dB = 12.9 W/kg = 11.11 dBW/kg

Impedance Measurement Plot for Body TSL

9 Apr 2014 11:02:32

CH1 S11 1 U FS 1: 48.752 Ω 6.3320 Ω 530.41 μ H 1 900.000 000 MHz

*
Del
CA
Avg
16
↑

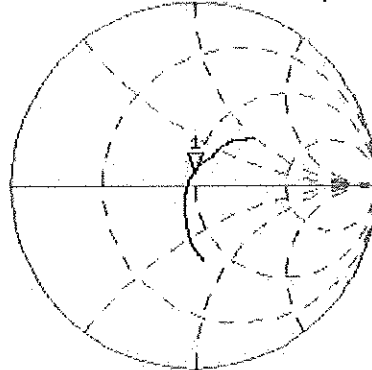

CH2 S11 LOG 5 dB/REF -20 dB 1: -23.715 dB 1 900.000 000 MHz

CA
Avg
16
↑

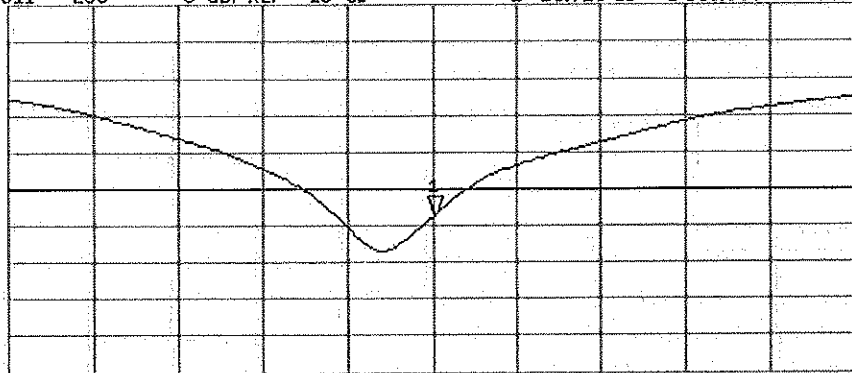



Accredited by the Swiss Accreditation Service (SAS)
The Swiss Accreditation Service is one of the signatories to the EA
Multilateral Agreement for the recognition of calibration certificates

Accreditation No.: **SCS 108**

Client **PC Test**

Certificate No: **D2450V2-719_Aug14**

CALIBRATION CERTIFICATE

Object **D2450V2 - SN: 719**

Calibration procedure(s) **QA CAL-05.v9
Calibration procedure for dipole validation kits above 700 MHz**

Calibration date: **August 11, 2014**

✓
KOK
9/8/14

This calibration certificate documents the traceability to national standards, which realize the physical units of measurements (SI).
The measurements and the uncertainties with confidence probability are given on the following pages and are part of the certificate.

All calibrations have been conducted in the closed laboratory facility: environment temperature (22 ± 3)°C and humidity < 70%.

Calibration Equipment used (M&TE critical for calibration)

Primary Standards	ID #	Cal Date (Certificate No.)	Scheduled Calibration
Power meter EPM-442A	GB37480704	09-Oct-13 (No. 217-01827)	Oct-14
Power sensor HP 8481A	US37292783	09-Oct-13 (No. 217-01827)	Oct-14
Power sensor HP 8481A	MY41092317	09-Oct-13 (No. 217-01828)	Oct-14
Reference 20 dB Attenuator	SN: 5058 (20k)	03-Apr-14 (No. 217-01918)	Apr-15
Type-N mismatch combination	SN: 5047.2 / 06327	03-Apr-14 (No. 217-01921)	Apr-15
Reference Probe ES3DV3	SN: 3205	30-Dec-13 (No. ES3-3205_Dec13)	Dec-14
DAE4	SN: 601	30-Apr-14 (No. DAE4-601_Apr14)	Apr-15
Secondary Standards	ID #	Check Date (in house)	Scheduled Check
RF generator R&S SMT-06	100005	04-Aug-99 (in house check Oct-13)	In house check: Oct-16
Network Analyzer HP 8753E	US37390585 S4206	18-Oct-01 (in house check Oct-13)	In house check: Oct-14

Calibrated by: **Michael Weber** Function: **Laboratory Technician** Signature: *M. Weber*

Approved by: **Katja Pokovic** Technical Manager *[Signature]*

Issued: August 12, 2014

This calibration certificate shall not be reproduced except in full without written approval of the laboratory.



Accredited by the Swiss Accreditation Service (SAS)
The Swiss Accreditation Service is one of the signatories to the EA
Multilateral Agreement for the recognition of calibration certificates

Glossary:

TSL	tissue simulating liquid
ConvF	sensitivity in TSL / NORM x,y,z
N/A	not applicable or not measured

Calibration is Performed According to the Following Standards:

- a) IEEE Std 1528-2013, "IEEE Recommended Practice for Determining the Peak Spatial-Averaged Specific Absorption Rate (SAR) in the Human Head from Wireless Communications Devices: Measurement Techniques", June 2013
- b) IEC 62209-1, "Procedure to measure the Specific Absorption Rate (SAR) for hand-held devices used in close proximity to the ear (frequency range of 300 MHz to 3 GHz)", February 2005
- c) KDB 865664, "SAR Measurement Requirements for 100 MHz to 6 GHz"

Additional Documentation:

- d) DASY4/5 System Handbook

Methods Applied and Interpretation of Parameters:

- *Measurement Conditions:* Further details are available from the Validation Report at the end of the certificate. All figures stated in the certificate are valid at the frequency indicated.
- *Antenna Parameters with TSL:* The dipole is mounted with the spacer to position its feed point exactly below the center marking of the flat phantom section, with the arms oriented parallel to the body axis.
- *Feed Point Impedance and Return Loss:* These parameters are measured with the dipole positioned under the liquid filled phantom. The impedance stated is transformed from the measurement at the SMA connector to the feed point. The Return Loss ensures low reflected power. No uncertainty required.
- *Electrical Delay:* One-way delay between the SMA connector and the antenna feed point. No uncertainty required.
- *SAR measured:* SAR measured at the stated antenna input power.
- *SAR normalized:* SAR as measured, normalized to an input power of 1 W at the antenna connector.
- *SAR for nominal TSL parameters:* The measured TSL parameters are used to calculate the nominal SAR result.

The reported uncertainty of measurement is stated as the standard uncertainty of measurement multiplied by the coverage factor $k=2$, which for a normal distribution corresponds to a coverage probability of approximately 95%.

Measurement Conditions

DASY system configuration, as far as not given on page 1.

DASY Version	DASY5	V52.8.8
Extrapolation	Advanced Extrapolation	
Phantom	Modular Flat Phantom	
Distance Dipole Center - TSL	10 mm	with Spacer
Zoom Scan Resolution	dx, dy, dz = 5 mm	
Frequency	2450 MHz \pm 1 MHz	

Head TSL parameters

The following parameters and calculations were applied.

	Temperature	Permittivity	Conductivity
Nominal Head TSL parameters	22.0 °C	39.2	1.80 mho/m
Measured Head TSL parameters	(22.0 \pm 0.2) °C	38.0 \pm 6 %	1.82 mho/m \pm 6 %
Head TSL temperature change during test	< 0.5 °C	----	----

SAR result with Head TSL

SAR averaged over 1 cm ³ (1 g) of Head TSL	Condition	
SAR measured	250 mW input power	13.2 W/kg
SAR for nominal Head TSL parameters	normalized to 1W	52.1 W/kg \pm 17.0 % (k=2)

SAR averaged over 10 cm ³ (10 g) of Head TSL	condition	
SAR measured	250 mW input power	6.09 W/kg
SAR for nominal Head TSL parameters	normalized to 1W	24.2 W/kg \pm 16.5 % (k=2)

Body TSL parameters

The following parameters and calculations were applied.

	Temperature	Permittivity	Conductivity
Nominal Body TSL parameters	22.0 °C	52.7	1.95 mho/m
Measured Body TSL parameters	(22.0 \pm 0.2) °C	50.5 \pm 6 %	2.02 mho/m \pm 6 %
Body TSL temperature change during test	< 0.5 °C	----	----

SAR result with Body TSL

SAR averaged over 1 cm ³ (1 g) of Body TSL	Condition	
SAR measured	250 mW input power	13.3 W/kg
SAR for nominal Body TSL parameters	normalized to 1W	51.8 W/kg \pm 17.0 % (k=2)

SAR averaged over 10 cm ³ (10 g) of Body TSL	condition	
SAR measured	250 mW input power	6.10 W/kg
SAR for nominal Body TSL parameters	normalized to 1W	24.0 W/kg \pm 16.5 % (k=2)

Appendix (Additional assessments outside the scope of SCS108)

Antenna Parameters with Head TSL

Impedance, transformed to feed point	54.9 Ω + 3.0 j Ω
Return Loss	- 25.2 dB

Antenna Parameters with Body TSL

Impedance, transformed to feed point	50.9 Ω + 5.8 j Ω
Return Loss	- 24.7 dB

General Antenna Parameters and Design

Electrical Delay (one direction)	1.149 ns
----------------------------------	----------

After long term use with 100W radiated power, only a slight warming of the dipole near the feedpoint can be measured.

The dipole is made of standard semirigid coaxial cable. The center conductor of the feeding line is directly connected to the second arm of the dipole. The antenna is therefore short-circuited for DC-signals. On some of the dipoles, small end caps are added to the dipole arms in order to improve matching when loaded according to the position as explained in the "Measurement Conditions" paragraph. The SAR data are not affected by this change. The overall dipole length is still according to the Standard.

No excessive force must be applied to the dipole arms, because they might bend or the soldered connections near the feedpoint may be damaged.

Additional EUT Data

Manufactured by	SPEAG
Manufactured on	September 10, 2002

DASY5 Validation Report for Head TSL

Date: 11.08.2014

Test Laboratory: SPEAG, Zurich, Switzerland

DUT: Dipole 2450 MHz; Type: D2450V2; Serial: D2450V2 - SN: 719

Communication System: UID 0 - CW; Frequency: 2450 MHz

Medium parameters used: $f = 2450$ MHz; $\sigma = 1.82$ S/m; $\epsilon_r = 38$; $\rho = 1000$ kg/m³

Phantom section: Flat Section

Measurement Standard: DASY5 (IEEE/IEC/ANSI C63.19-2011)

DASY52 Configuration:

- Probe: ES3DV3 - SN3205; ConvF(4.53, 4.53, 4.53); Calibrated: 30.12.2013;
- Sensor-Surface: 3mm (Mechanical Surface Detection)
- Electronics: DAE4 Sn601; Calibrated: 30.04.2014
- Phantom: Flat Phantom 5.0 (front); Type: QD000P50AA; Serial: 1001
- DASY52 52.8.8(1222); SEMCAD X 14.6.10(7331)

Dipole Calibration for Head Tissue/Pin=250 mW, d=10mm/Zoom Scan (7x7x7)/Cube 0:

Measurement grid: dx=5mm, dy=5mm, dz=5mm

Reference Value = 101.6 V/m; Power Drift = 0.03 dB

Peak SAR (extrapolated) = 27.5 W/kg

SAR(1 g) = 13.2 W/kg; SAR(10 g) = 6.09 W/kg

Maximum value of SAR (measured) = 17.4 W/kg

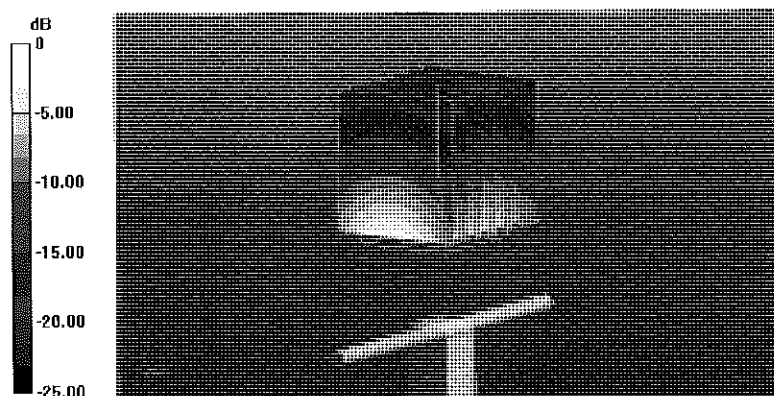

0 dB = 17.4 W/kg = 12.41 dBW/kg

Impedance Measurement Plot for Head TSL

11 Aug 2014 11:49:06

CH1 S11 1 U FS

1: 54.887 Ω 3.0391 Ω 197.42 pF

2 450.000 000 MHz

Del
C Δ

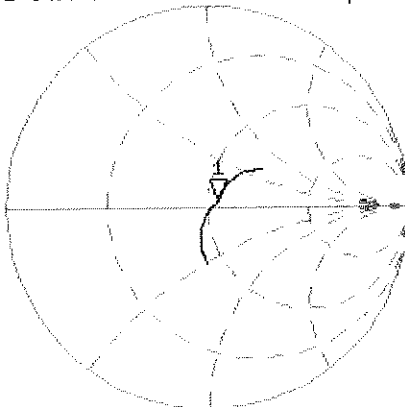

Avg
16

H1 d

CH2 S11 LOG 5 dB/REF -20 dB 1: -25.212 dB 2 450.000 000 MHz

C Δ

Avg
16

H1 d

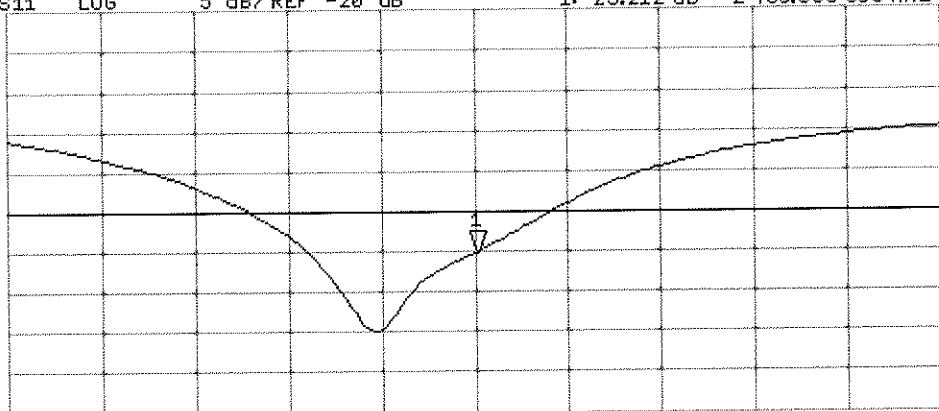

START 2 250.000 000 MHz

STOP 2 650.000 000 MHz

DASY5 Validation Report for Body TSL

Date: 11.08.2014

Test Laboratory: SPEAG, Zurich, Switzerland

DUT: Dipole 2450 MHz; Type: D2450V2; Serial: D2450V2 - SN: 719

Communication System: UID 0 - CW; Frequency: 2450 MHz

Medium parameters used: $f = 2450$ MHz; $\sigma = 2.02$ S/m; $\epsilon_r = 50.5$; $\rho = 1000$ kg/m³

Phantom section: Flat Section

Measurement Standard: DASY5 (IEEE/IEC/ANSI C63.19-2011)

DASY52 Configuration:

- Probe: ES3DV3 - SN3205; ConvF(4.35, 4.35, 4.35); Calibrated: 30.12.2013;
- Sensor-Surface: 3mm (Mechanical Surface Detection)
- Electronics: DAE4 Sn601; Calibrated: 30.04.2014
- Phantom: Flat Phantom 5.0 (back); Type: QD000P50AA; Serial: 1002
- DASY52 52.8.8(1222); SEMCAD X 14.6.10(7331)

Dipole Calibration for Body Tissue/ $P_{in}=250$ mW, $d=10$ mm/Zoom Scan (7x7x7)/Cube 0:

Measurement grid: $dx=5$ mm, $dy=5$ mm, $dz=5$ mm

Reference Value = 96.08 V/m; Power Drift = -0.01 dB

Peak SAR (extrapolated) = 27.9 W/kg

SAR(1 g) = 13.3 W/kg; SAR(10 g) = 6.1 W/kg

Maximum value of SAR (measured) = 17.6 W/kg

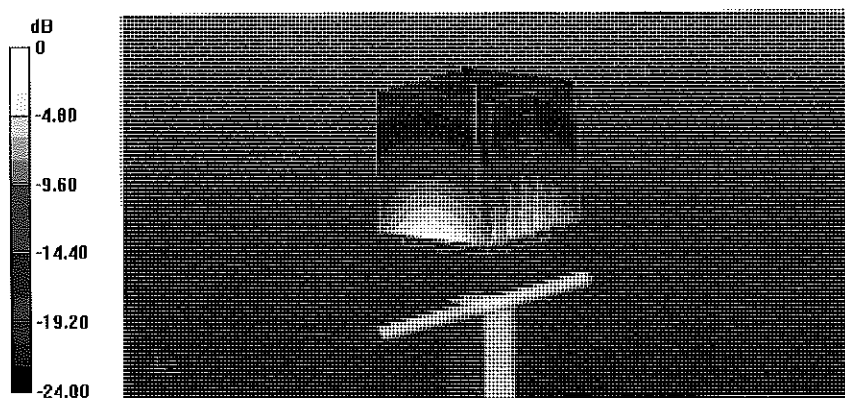

0 dB = 17.6 W/kg = 12.46 dBW/kg

Impedance Measurement Plot for Body TSL

11 Aug 2014 11:48:32

CH1 S11 1 U FS 1: 50.928 Δ 5.8223 Δ 378.22 pF 2 450.000 000 MHz

*
De1
CA

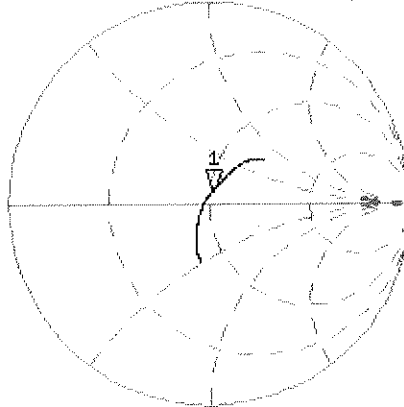

Avg
1E
H1d

CH2 S11 LOG 5 dB/REF -20 dB 1: -24.679 dB 2 450.000 000 MHz

CA
Avg
1E
H1d

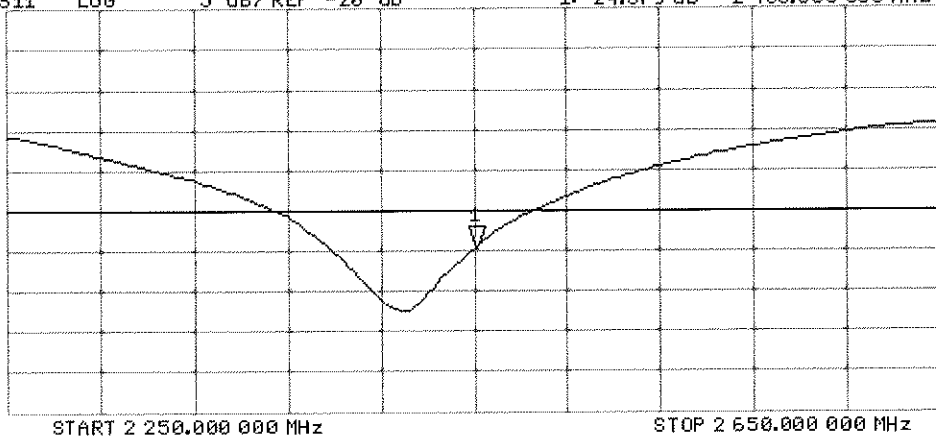



Accredited by the Swiss Accreditation Service (SAS)
The Swiss Accreditation Service is one of the signatories to the EA
Multilateral Agreement for the recognition of calibration certificates

Accreditation No.: **SCS 0108**

Client **PC Test**

Certificate No: **D5GHzV2-1057_Jan15**

CALIBRATION CERTIFICATE

Object **D5GHzV2 - SN:1057**

Calibration procedure(s) **QA CAL-22.v2
Calibration procedure for dipole validation kits between 3-6 GHz**

CC
2/3/15

Calibration date: **January 21, 2015**

This calibration certificate documents the traceability to national standards, which realize the physical units of measurements (SI).
The measurements and the uncertainties with confidence probability are given on the following pages and are part of the certificate.

All calibrations have been conducted in the closed laboratory facility: environment temperature (22 ± 3)°C and humidity < 70%.

Calibration Equipment used (M&TE critical for calibration)

Primary Standards	ID #	Cal Date (Certificate No.)	Scheduled Calibration
Power meter EPM-442A	GB37480704	07-Oct-14 (No. 217-02020)	Oct-15
Power sensor HP 8481A	US37292783	07-Oct-14 (No. 217-02020)	Oct-15
Power sensor HP 8481A	MY41092317	07-Oct-14 (No. 217-02021)	Oct-15
Reference 20 dB Attenuator	SN: 5058 (20k)	03-Apr-14 (No. 217-01918)	Apr-15
Type-N mismatch combination	SN: 5047.2 / 06327	03-Apr-14 (No. 217-01921)	Apr-15
Reference Probe EX3DV4	SN: 3503	30-Dec-14 (No. EX3-3503_Dec14)	Dec-15
DAE4	SN: 601	18-Aug-14 (No. DAE4-601_Aug14)	Aug-15
Secondary Standards	ID #	Check Date (in house)	Scheduled Check
RF generator R&S SMT-06	100005	04-Aug-99 (in house check Oct-13)	In house check: Oct-16
Network Analyzer HP 8753E	US37390585 S4206	18-Oct-01 (in house check Oct-14)	In house check: Oct-15

Calibrated by: **Name** Michael Weber **Function** Laboratory Technician

Signature

Approved by: **Name** Katja Pokovic **Function** Technical Manager

Issued: January 22, 2015

This calibration certificate shall not be reproduced except in full without written approval of the laboratory.



Accredited by the Swiss Accreditation Service (SAS)
The Swiss Accreditation Service is one of the signatories to the EA
Multilateral Agreement for the recognition of calibration certificates

Accreditation No.: **SCS 0108**

Glossary:

TSL	tissue simulating liquid
ConvF	sensitivity in TSL / NORM x,y,z
N/A	not applicable or not measured

Calibration is Performed According to the Following Standards:

- a) IEC 62209-2, "Evaluation of Human Exposure to Radio Frequency Fields from Handheld and Body-Mounted Wireless Communication Devices in the Frequency Range of 30 MHz to 6 GHz: Human models, Instrumentation, and Procedures"; Part 2: "Procedure to determine the Specific Absorption Rate (SAR) for including accessories and multiple transmitters", March 2010
- b) KDB 865664, "SAR Measurement Requirements for 100 MHz to 6 GHz"
- c) IEEE Std 1528-2013, "IEEE Recommended Practice for Determining the Peak Spatial-Averaged Specific Absorption Rate (SAR) in the Human Head from Wireless Communications Devices: Measurement Techniques", June 2013

Additional Documentation:

- d) DASY4/5 System Handbook

Methods Applied and Interpretation of Parameters:

- *Measurement Conditions:* Further details are available from the Validation Report at the end of the certificate. All figures stated in the certificate are valid at the frequency indicated.
- *Antenna Parameters with TSL:* The dipole is mounted with the spacer to position its feed point exactly below the center marking of the flat phantom section, with the arms oriented parallel to the body axis.
- *Feed Point Impedance and Return Loss:* These parameters are measured with the dipole positioned under the liquid filled phantom. The impedance stated is transformed from the measurement at the SMA connector to the feed point. The Return Loss ensures low reflected power. No uncertainty required.
- *Electrical Delay:* One-way delay between the SMA connector and the antenna feed point. No uncertainty required.
- *SAR measured:* SAR measured at the stated antenna input power.
- *SAR normalized:* SAR as measured, normalized to an input power of 1 W at the antenna connector.
- *SAR for nominal TSL parameters:* The measured TSL parameters are used to calculate the nominal SAR result.

The reported uncertainty of measurement is stated as the standard uncertainty of measurement multiplied by the coverage factor $k=2$, which for a normal distribution corresponds to a coverage probability of approximately 95%.

Measurement Conditions

DASY system configuration, as far as not given on page 1.

DASY Version	DASY5	V52.8.8
Extrapolation	Advanced Extrapolation	
Phantom	Modular Flat Phantom V5.0	
Distance Dipole Center - TSL	10 mm	with Spacer
Zoom Scan Resolution	dx, dy = 4.0 mm, dz = 1.4 mm	Graded Ratio = 1.4 (Z direction)
Frequency	5200 MHz ± 1 MHz 5300 MHz ± 1 MHz 5500 MHz ± 1 MHz 5600 MHz ± 1 MHz 5800 MHz ± 1 MHz	

Head TSL parameters at 5200 MHz

The following parameters and calculations were applied.

	Temperature	Permittivity	Conductivity
Nominal Head TSL parameters	22.0 °C	36.0	4.66 mho/m
Measured Head TSL parameters	(22.0 ± 0.2) °C	36.3 ± 6 %	4.56 mho/m ± 6 %
Head TSL temperature change during test	< 0.5 °C	----	----

SAR result with Head TSL at 5200 MHz

SAR averaged over 1 cm ³ (1 g) of Head TSL	Condition	
SAR measured	100 mW input power	8.14 W/kg
SAR for nominal Head TSL parameters	normalized to 1W	81.5 W/kg ± 19.9 % (k=2)

SAR averaged over 10 cm ³ (10 g) of Head TSL	condition	
SAR measured	100 mW input power	2.31 W/kg
SAR for nominal Head TSL parameters	normalized to 1W	23.1 W/kg ± 19.5 % (k=2)

Head TSL parameters at 5300 MHz

The following parameters and calculations were applied.

	Temperature	Permittivity	Conductivity
Nominal Head TSL parameters	22.0 °C	35.9	4.76 mho/m
Measured Head TSL parameters	(22.0 ± 0.2) °C	36.1 ± 6 %	4.66 mho/m ± 6 %
Head TSL temperature change during test	< 0.5 °C	----	----

SAR result with Head TSL at 5300 MHz

SAR averaged over 1 cm ³ (1 g) of Head TSL	Condition	
SAR measured	100 mW input power	8.47 W/kg
SAR for nominal Head TSL parameters	normalized to 1W	84.7 W / kg ± 19.9 % (k=2)

SAR averaged over 10 cm ³ (10 g) of Head TSL	condition	
SAR measured	100 mW input power	2.41 W/kg
SAR for nominal Head TSL parameters	normalized to 1W	24.1 W/kg ± 19.5 % (k=2)

Head TSL parameters at 5500 MHz

The following parameters and calculations were applied.

	Temperature	Permittivity	Conductivity
Nominal Head TSL parameters	22.0 °C	35.6	4.96 mho/m
Measured Head TSL parameters	(22.0 ± 0.2) °C	35.9 ± 6 %	4.86 mho/m ± 6 %
Head TSL temperature change during test	< 0.5 °C	----	----

SAR result with Head TSL at 5500 MHz

SAR averaged over 1 cm ³ (1 g) of Head TSL	Condition	
SAR measured	100 mW input power	8.43 W/kg
SAR for nominal Head TSL parameters	normalized to 1W	84.3 W/kg ± 19.9 % (k=2)

SAR averaged over 10 cm ³ (10 g) of Head TSL	condition	
SAR measured	100 mW input power	2.38 W/kg
SAR for nominal Head TSL parameters	normalized to 1W	23.8 W/kg ± 19.5 % (k=2)

Head TSL parameters at 5600 MHz

The following parameters and calculations were applied.

	Temperature	Permittivity	Conductivity
Nominal Head TSL parameters	22.0 °C	35.5	5.07 mho/m
Measured Head TSL parameters	(22.0 ± 0.2) °C	35.6 ± 6 %	4.97 mho/m ± 6 %
Head TSL temperature change during test	< 0.5 °C	----	----

SAR result with Head TSL at 5600 MHz

SAR averaged over 1 cm ³ (1 g) of Head TSL	Condition	
SAR measured	100 mW input power	8.38 W/kg
SAR for nominal Head TSL parameters	normalized to 1W	83.8 W/kg ± 19.9 % (k=2)

SAR averaged over 10 cm ³ (10 g) of Head TSL	condition	
SAR measured	100 mW input power	2.37 W/kg
SAR for nominal Head TSL parameters	normalized to 1W	23.7 W/kg ± 19.5 % (k=2)

Head TSL parameters at 5800 MHz

The following parameters and calculations were applied.

	Temperature	Permittivity	Conductivity
Nominal Head TSL parameters	22.0 °C	35.3	5.27 mho/m
Measured Head TSL parameters	(22.0 ± 0.2) °C	35.4 ± 6 %	5.18 mho/m ± 6 %
Head TSL temperature change during test	< 0.5 °C	----	----

SAR result with Head TSL at 5800 MHz

SAR averaged over 1 cm ³ (1 g) of Head TSL	Condition	
SAR measured	100 mW input power	8.11 W/kg
SAR for nominal Head TSL parameters	normalized to 1W	81.1 W/kg ± 19.9 % (k=2)

SAR averaged over 10 cm ³ (10 g) of Head TSL	condition	
SAR measured	100 mW input power	2.29 W/kg
SAR for nominal Head TSL parameters	normalized to 1W	22.9 W/kg ± 19.5 % (k=2)

Body TSL parameters at 5200 MHz

The following parameters and calculations were applied.

	Temperature	Permittivity	Conductivity
Nominal Body TSL parameters	22.0 °C	49.0	5.30 mho/m
Measured Body TSL parameters	(22.0 ± 0.2) °C	49.4 ± 6 %	5.42 mho/m ± 6 %
Body TSL temperature change during test	< 0.5 °C	----	----

SAR result with Body TSL at 5200 MHz

SAR averaged over 1 cm ³ (1 g) of Body TSL	Condition	
SAR measured	100 mW input power	7.37 W/kg
SAR for nominal Body TSL parameters	normalized to 1W	73.9 W/kg ± 19.9 % (k=2)

SAR averaged over 10 cm ³ (10 g) of Body TSL	condition	
SAR measured	100 mW input power	2.05 W/kg
SAR for nominal Body TSL parameters	normalized to 1W	20.6 W/kg ± 19.5 % (k=2)

Body TSL parameters at 5300 MHz

The following parameters and calculations were applied.

	Temperature	Permittivity	Conductivity
Nominal Body TSL parameters	22.0 °C	48.9	5.42 mho/m
Measured Body TSL parameters	(22.0 ± 0.2) °C	49.2 ± 6 %	5.55 mho/m ± 6 %
Body TSL temperature change during test	< 0.5 °C	----	----

SAR result with Body TSL at 5300 MHz

SAR averaged over 1 cm ³ (1 g) of Body TSL	Condition	
SAR measured	100 mW input power	7.41 W/kg
SAR for nominal Body TSL parameters	normalized to 1W	74.2 W/kg ± 19.9 % (k=2)

SAR averaged over 10 cm ³ (10 g) of Body TSL	condition	
SAR measured	100 mW input power	2.08 W/kg
SAR for nominal Body TSL parameters	normalized to 1W	20.9 W/kg ± 19.5 % (k=2)

Body TSL parameters at 5500 MHz

The following parameters and calculations were applied.

	Temperature	Permittivity	Conductivity
Nominal Body TSL parameters	22.0 °C	48.6	5.65 mho/m
Measured Body TSL parameters	(22.0 ± 0.2) °C	48.9 ± 6 %	5.82 mho/m ± 6 %
Body TSL temperature change during test	< 0.5 °C	----	----

SAR result with Body TSL at 5500 MHz

SAR averaged over 1 cm ³ (1 g) of Body TSL	Condition	
SAR measured	100 mW input power	7.90 W/kg
SAR for nominal Body TSL parameters	normalized to 1W	79.2 W/kg ± 19.9 % (k=2)

SAR averaged over 10 cm ³ (10 g) of Body TSL	condition	
SAR measured	100 mW input power	2.19 W/kg
SAR for nominal Body TSL parameters	normalized to 1W	22.0 W/kg ± 19.5 % (k=2)

Body TSL parameters at 5600 MHz

The following parameters and calculations were applied.

	Temperature	Permittivity	Conductivity
Nominal Body TSL parameters	22.0 °C	48.5	5.77 mho/m
Measured Body TSL parameters	(22.0 ± 0.2) °C	48.7 ± 6 %	5.96 mho/m ± 6 %
Body TSL temperature change during test	< 0.5 °C	----	----

SAR result with Body TSL at 5600 MHz

SAR averaged over 1 cm ³ (1 g) of Body TSL	Condition	
SAR measured	100 mW input power	7.75 W/kg
SAR for nominal Body TSL parameters	normalized to 1W	77.7 W/kg ± 19.9 % (k=2)

SAR averaged over 10 cm ³ (10 g) of Body TSL	condition	
SAR measured	100 mW input power	2.14 W/kg
SAR for nominal Body TSL parameters	normalized to 1W	21.5 W/kg ± 19.5 % (k=2)

Body TSL parameters at 5800 MHz

The following parameters and calculations were applied.

	Temperature	Permittivity	Conductivity
Nominal Body TSL parameters	22.0 °C	48.2	6.00 mho/m
Measured Body TSL parameters	(22.0 ± 0.2) °C	48.4 ± 6 %	6.25 mho/m ± 6 %
Body TSL temperature change during test	< 0.5 °C	----	----

SAR result with Body TSL at 5800 MHz

SAR averaged over 1 cm ³ (1 g) of Body TSL	Condition	
SAR measured	100 mW input power	7.49 W/kg
SAR for nominal Body TSL parameters	normalized to 1W	75.1 W/kg ± 19.9 % (k=2)

SAR averaged over 10 cm ³ (10 g) of Body TSL	condition	
SAR measured	100 mW input power	2.06 W/kg
SAR for nominal Body TSL parameters	normalized to 1W	20.6 W/kg ± 19.5 % (k=2)

Appendix (Additional assessments outside the scope of SCS0108)

Antenna Parameters with Head TSL at 5200 MHz

Impedance, transformed to feed point	49.0 Ω - 9.4 j Ω
Return Loss	- 20.4 dB

Antenna Parameters with Head TSL at 5300 MHz

Impedance, transformed to feed point	48.3 Ω - 4.2 j Ω
Return Loss	- 26.8 dB

Antenna Parameters with Head TSL at 5500 MHz

Impedance, transformed to feed point	49.2 Ω - 5.0 j Ω
Return Loss	- 25.9 dB

Antenna Parameters with Head TSL at 5600 MHz

Impedance, transformed to feed point	54.4 Ω - 4.8 j Ω
Return Loss	- 24.1 dB

Antenna Parameters with Head TSL at 5800 MHz

Impedance, transformed to feed point	51.8 Ω - 2.6 j Ω
Return Loss	- 30.1 dB

Antenna Parameters with Body TSL at 5200 MHz

Impedance, transformed to feed point	48.2 Ω - 8.4 j Ω
Return Loss	- 21.2 dB

Antenna Parameters with Body TSL at 5300 MHz

Impedance, transformed to feed point	48.6 Ω - 3.6 j Ω
Return Loss	- 28.2 dB

Antenna Parameters with Body TSL at 5500 MHz

Impedance, transformed to feed point	49.4 Ω - 4.1 j Ω
Return Loss	- 27.6 dB

Antenna Parameters with Body TSL at 5600 MHz

Impedance, transformed to feed point	55.1 Ω - 4.0 j Ω
Return Loss	- 24.2 dB

Antenna Parameters with Body TSL at 5800 MHz

Impedance, transformed to feed point	51.6 Ω - 1.6 j Ω
Return Loss	- 33.0 dB

General Antenna Parameters and Design

Electrical Delay (one direction)	1.202 ns
----------------------------------	----------

After long term use with 100W radiated power, only a slight warming of the dipole near the feedpoint can be measured.

The dipole is made of standard semirigid coaxial cable. The center conductor of the feeding line is directly connected to the second arm of the dipole. The antenna is therefore short-circuited for DC-signals. On some of the dipoles, small end caps are added to the dipole arms in order to improve matching when loaded according to the position as explained in the "Measurement Conditions" paragraph. The SAR data are not affected by this change. The overall dipole length is still according to the Standard.

No excessive force must be applied to the dipole arms, because they might bend or the soldered connections near the feedpoint may be damaged.

Additional EUT Data

Manufactured by	SPEAG
Manufactured on	November 27, 2006

DASY5 Validation Report for Head TSL

Date: 21.01.2015

Test Laboratory: SPEAG, Zurich, Switzerland

DUT: Dipole 5GHz; Type: D5GHzV2; Serial: D5GHzV2 - SN:1057

Communication System: UID 0 - CW; Frequency: 5200 MHz, Frequency: 5300 MHz, Frequency: 5500 MHz, Frequency: 5600 MHz, Frequency: 5800 MHz

Medium parameters used: $f = 5200$ MHz; $\sigma = 4.56$ S/m; $\epsilon_r = 36.3$; $\rho = 1000$ kg/m³, Medium parameters used: $f = 5300$ MHz; $\sigma = 4.66$ S/m; $\epsilon_r = 36.1$; $\rho = 1000$ kg/m³, Medium parameters used: $f = 5500$ MHz; $\sigma = 4.86$ S/m; $\epsilon_r = 35.9$; $\rho = 1000$ kg/m³, Medium parameters used: $f = 5600$ MHz; $\sigma = 4.97$ S/m; $\epsilon_r = 35.6$; $\rho = 1000$ kg/m³, Medium parameters used: $f = 5800$ MHz; $\sigma = 5.18$ S/m; $\epsilon_r = 35.4$; $\rho = 1000$ kg/m³

Phantom section: Flat Section

Measurement Standard: DASY5 (IEEE/IEC/ANSI C63.19-2011)

DASY52 Configuration:

- Probe: EX3DV4 - SN3503; ConvF(5.51, 5.51, 5.51); Calibrated: 30.12.2014, ConvF(5.21, 5.21, 5.21); Calibrated: 30.12.2014, ConvF(5.12, 5.12, 5.12); Calibrated: 30.12.2014, ConvF(4.92, 4.92, 4.92); Calibrated: 30.12.2014, ConvF(4.9, 4.9, 4.9); Calibrated: 30.12.2014;
- Sensor-Surface: 1.4mm (Mechanical Surface Detection)
- Electronics: DAE4 Sn601; Calibrated: 18.08.2014
- Phantom: Flat Phantom 5.0 (front); Type: QD000P50AA; Serial: 1001
- DASY52 52.8.8(1222); SEMCAD X 14.6.10(7331)

Dipole Calibration for Head Tissue/Pin=100mW, dist=10mm, f=5200 MHz/Zoom Scan, dist=1.4mm (8x8x7)/Cube 0: Measurement grid: dx=4mm, dy=4mm, dz=1.4mm

Reference Value = 65.51 V/m; Power Drift = -0.02 dB

Peak SAR (extrapolated) = 29.8 W/kg

SAR(1 g) = 8.14 W/kg; SAR(10 g) = 2.31 W/kg

Maximum value of SAR (measured) = 19.3 W/kg

Dipole Calibration for Head Tissue/Pin=100mW, dist=10mm, f=5300 MHz/Zoom Scan, dist=1.4mm (8x8x7)/Cube 0: Measurement grid: dx=4mm, dy=4mm, dz=1.4mm

Reference Value = 65.30 V/m; Power Drift = 0.06 dB

Peak SAR (extrapolated) = 32.1 W/kg

SAR(1 g) = 8.47 W/kg; SAR(10 g) = 2.41 W/kg

Maximum value of SAR (measured) = 20.4 W/kg

Dipole Calibration for Head Tissue/Pin=100mW, dist=10mm, f=5500 MHz/Zoom Scan, dist=1.4mm (8x8x7)/Cube 0: Measurement grid: dx=4mm, dy=4mm, dz=1.4mm

Reference Value = 64.33 V/m; Power Drift = 0.07 dB

Peak SAR (extrapolated) = 33.5 W/kg

SAR(1 g) = 8.43 W/kg; SAR(10 g) = 2.38 W/kg

Maximum value of SAR (measured) = 20.6 W/kg

Dipole Calibration for Head Tissue/Pin=100mW, dist=10mm, f=5600 MHz/Zoom Scan, dist=1.4mm (8x8x7)/Cube 0: Measurement grid: dx=4mm, dy=4mm, dz=1.4mm
Reference Value = 64.47 V/m; Power Drift = 0.09 dB
Peak SAR (extrapolated) = 33.5 W/kg
SAR(1 g) = 8.38 W/kg; SAR(10 g) = 2.37 W/kg
Maximum value of SAR (measured) = 20.2 W/kg

Dipole Calibration for Head Tissue/Pin=100mW, dist=10mm, f=5800 MHz/Zoom Scan, dist=1.4mm (8x8x7)/Cube 0: Measurement grid: dx=4mm, dy=4mm, dz=1.4mm
Reference Value = 62.34 V/m; Power Drift = 0.06 dB
Peak SAR (extrapolated) = 33.8 W/kg
SAR(1 g) = 8.11 W/kg; SAR(10 g) = 2.29 W/kg
Maximum value of SAR (measured) = 19.8 W/kg

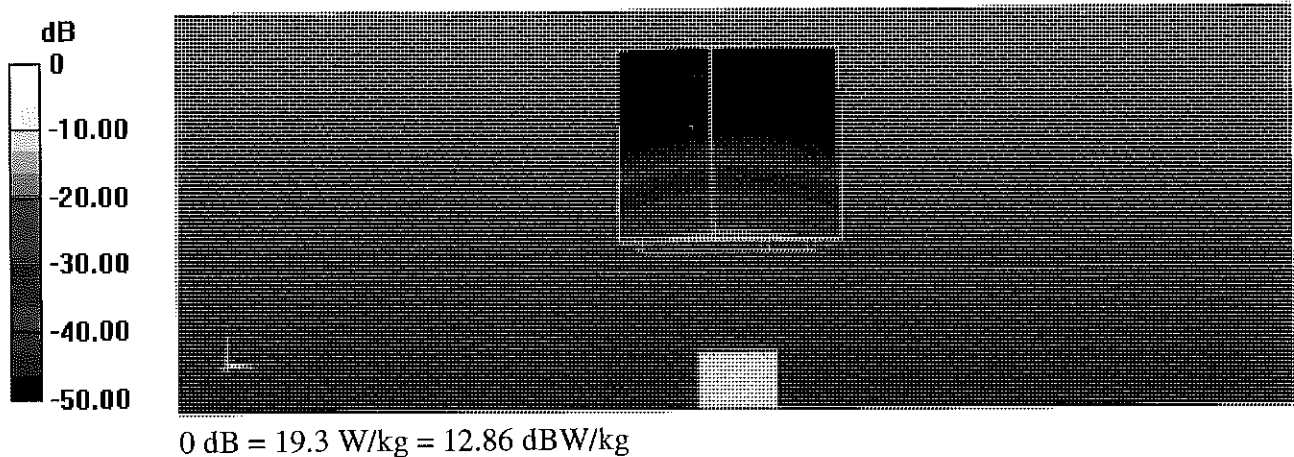

Impedance Measurement Plot for Head TSL

21 Jan 2015 18:20:46

CH1 S11 1 U FS 1: 48.969 Ω -9.4141 Ω 3.2512 pF 5 200.000 000 MHz

*
Del
Cor
Avg
16
H1d

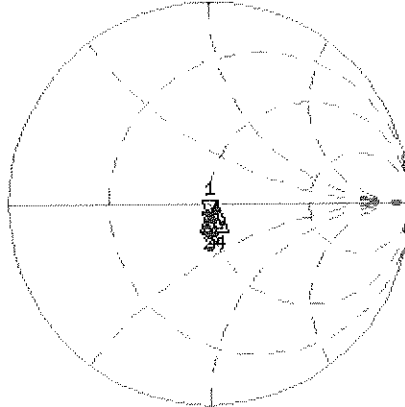

CH1 Markers
2: 48.281 Ω
-4.1660 Ω
5.30000 GHz
3: 49.166 Ω
-4.9727 Ω
5.50000 GHz
4: 54.434 Ω
-4.7793 Ω
5.60000 GHz
5: 51.846 Ω
-2.5781 Ω
5.80000 GHz

CH2 S11 LOG 5 dB/REF -20 dB 1: -20.422 dB 5 200.000 000 MHz

Cor
Avg
16
H1d

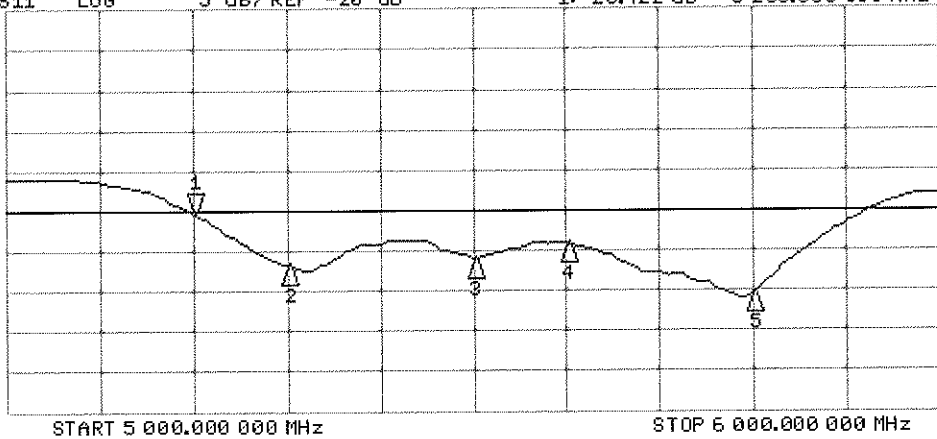

CH2 Markers
2: -26.780 dB
5.30000 GHz
3: -25.882 dB
5.50000 GHz
4: -24.101 dB
5.60000 GHz
5: -30.135 dB
5.80000 GHz

START 5 000.000 000 MHz

STOP 6 000.000 000 MHz

DASY5 Validation Report for Body TSL

Date: 20.01.2015

Test Laboratory: SPEAG, Zurich, Switzerland

DUT: Dipole 5GHz; Type: D5GHzV2; Serial: D5GHzV2 - SN:1057

Communication System: UID 0 - CW; Frequency: 5200 MHz, Frequency: 5300 MHz, Frequency: 5500 MHz, Frequency: 5600 MHz, Frequency: 5800 MHz

Medium parameters used: $f = 5200$ MHz; $\sigma = 5.42$ S/m; $\epsilon_r = 49.4$; $\rho = 1000$ kg/m³, Medium parameters used: $f = 5300$ MHz; $\sigma = 5.55$ S/m; $\epsilon_r = 49.2$; $\rho = 1000$ kg/m³, Medium parameters used: $f = 5500$ MHz; $\sigma = 5.82$ S/m; $\epsilon_r = 48.9$; $\rho = 1000$ kg/m³, Medium parameters used: $f = 5600$ MHz; $\sigma = 5.96$ S/m; $\epsilon_r = 48.7$; $\rho = 1000$ kg/m³, Medium parameters used: $f = 5800$ MHz; $\sigma = 6.25$ S/m; $\epsilon_r = 48.4$; $\rho = 1000$ kg/m³

Phantom section: Flat Section

Measurement Standard: DASY5 (IEEE/IEC/ANSI C63.19-2011)

DASY52 Configuration:

- Probe: EX3DV4 - SN3503; ConvF(4.95, 4.95, 4.95); Calibrated: 30.12.2014, ConvF(4.78, 4.78, 4.78); Calibrated: 30.12.2014, ConvF(4.45, 4.45, 4.45); Calibrated: 30.12.2014, ConvF(4.35, 4.35, 4.35); Calibrated: 30.12.2014, ConvF(4.32, 4.32, 4.32); Calibrated: 30.12.2014;
- Sensor-Surface: 1.4mm (Mechanical Surface Detection)
- Electronics: DAE4 Sn601; Calibrated: 18.08.2014
- Phantom: Flat Phantom 5.0 (back); Type: QD000P50AA; Serial: 1002
- DASY52 52.8.8(1222); SEMCAD X 14.6.10(7331)

Dipole Calibration for Body Tissue/Pin=100mW, dist=10mm, f=5200 MHz/Zoom Scan, dist=1.4mm (8x8x7)/Cube 0: Measurement grid: dx=4mm, dy=4mm, dz=1.4mm

Reference Value = 58.76 V/m; Power Drift = -0.03 dB

Peak SAR (extrapolated) = 28.9 W/kg

SAR(1 g) = 7.37 W/kg; SAR(10 g) = 2.05 W/kg

Maximum value of SAR (measured) = 17.4 W/kg

Dipole Calibration for Body Tissue/Pin=100mW, dist=10mm, f=5300 MHz/Zoom Scan, dist=1.4mm (8x8x7)/Cube 0: Measurement grid: dx=4mm, dy=4mm, dz=1.4mm

Reference Value = 58.35 V/m; Power Drift = 0.01 dB

Peak SAR (extrapolated) = 29.8 W/kg

SAR(1 g) = 7.41 W/kg; SAR(10 g) = 2.08 W/kg

Maximum value of SAR (measured) = 17.6 W/kg

Dipole Calibration for Body Tissue/Pin=100mW, dist=10mm, f=5500 MHz/Zoom Scan, dist=1.4mm (8x8x7)/Cube 0: Measurement grid: dx=4mm, dy=4mm, dz=1.4mm

Reference Value = 59.04 V/m; Power Drift = 0.01 dB

Peak SAR (extrapolated) = 33.7 W/kg

SAR(1 g) = 7.9 W/kg; SAR(10 g) = 2.19 W/kg

Maximum value of SAR (measured) = 19.2 W/kg

Dipole Calibration for Body Tissue/Pin=100mW, dist=10mm, f=5600 MHz/Zoom Scan, dist=1.4mm (8x8x7)/Cube 0: Measurement grid: dx=4mm, dy=4mm, dz=1.4mm

Reference Value = 57.74 V/m; Power Drift = 0.01 dB

Peak SAR (extrapolated) = 34.1 W/kg

SAR(1 g) = 7.75 W/kg; SAR(10 g) = 2.14 W/kg

Maximum value of SAR (measured) = 19.1 W/kg

Dipole Calibration for Body Tissue/Pin=100mW, dist=10mm, f=5800 MHz/Zoom Scan, dist=1.4mm (8x8x7)/Cube 0: Measurement grid: dx=4mm, dy=4mm, dz=1.4mm

Reference Value = 55.86 V/m; Power Drift = -0.01 dB

Peak SAR (extrapolated) = 34.7 W/kg

SAR(1 g) = 7.49 W/kg; SAR(10 g) = 2.06 W/kg

Maximum value of SAR (measured) = 18.6 W/kg

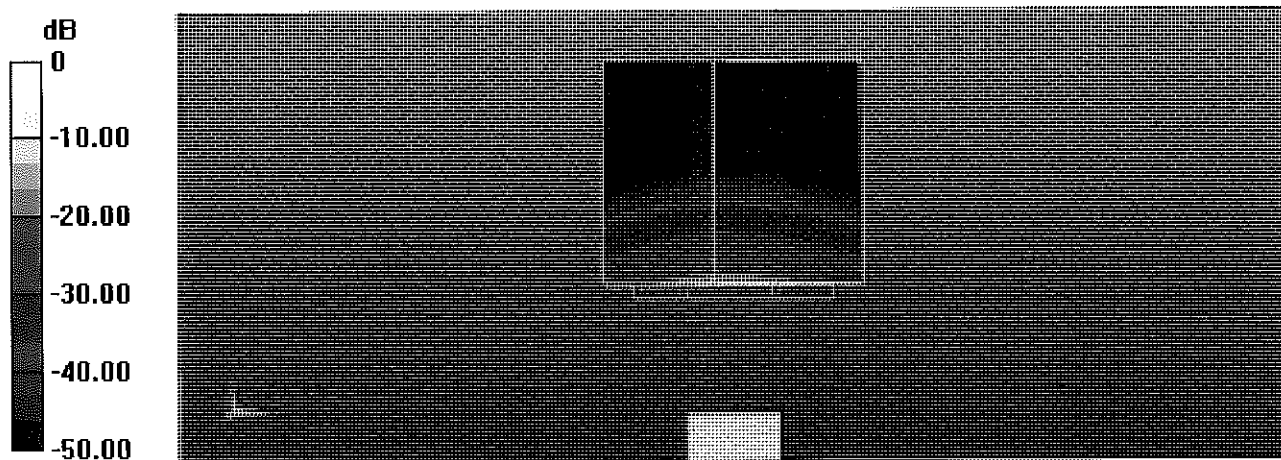

0 dB = 17.4 W/kg = 12.41 dBW/kg

Impedance Measurement Plot for Body TSL

20 Jan 2015 12:31:19

CH1 S11 1 U FS 1: 48.223 Ω -8.4023 Ω 3.6426 pF 5 200.000 000 MHz

*
Del
Cor
Avg
16
H1d

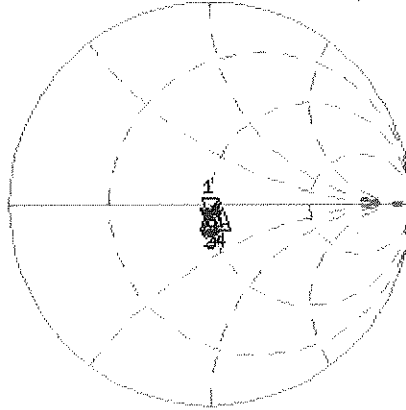

CH1 Markers

- 2: 48.646 Ω
-3.6016 Ω
5.30000 GHz
- 3: 49.350 Ω
-4.0879 Ω
5.50000 GHz
- 4: 55.062 Ω
-4.0215 Ω
5.60000 GHz
- 5: 51.545 Ω
-1.5840 Ω
5.80000 GHz

CH2 S11 LOG 5 dB/REF -20 dB 1: -21.137 dB 5 200.000 000 MHz

Cor
Avg
16
H1d

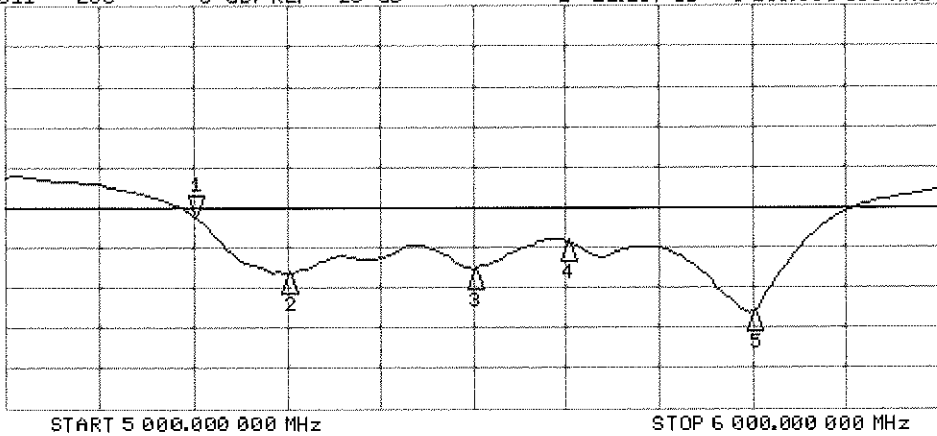

CH2 Markers

- 2: -28.183 dB
5.30000 GHz
- 3: -27.611 dB
5.50000 GHz
- 4: -24.217 dB
5.60000 GHz
- 5: -32.954 dB
5.80000 GHz



Accredited by the Swiss Accreditation Service (SAS)
The Swiss Accreditation Service is one of the signatories to the EA
Multilateral Agreement for the recognition of calibration certificates

Accreditation No.: **SCS 0108**

Client **PC Test**

Certificate No: **D835V2-4d132_Jan15**

CALIBRATION CERTIFICATE

Object **D835V2 - SN: 4d132**

Calibration procedure(s) **QA CAL-05.v9
Calibration procedure for dipole validation kits above 700 MHz**

*CC
2/3/15*

Calibration date: **January 16, 2015**

This calibration certificate documents the traceability to national standards, which realize the physical units of measurements (SI).
The measurements and the uncertainties with confidence probability are given on the following pages and are part of the certificate.

All calibrations have been conducted in the closed laboratory facility: environment temperature (22 ± 3)°C and humidity < 70%.

Calibration Equipment used (M&TE critical for calibration)

Primary Standards	ID #	Cal Date (Certificate No.)	Scheduled Calibration
Power meter EPM-442A	GB37480704	07-Oct-14 (No. 217-02020)	Oct-15
Power sensor HP 8481A	US37292783	07-Oct-14 (No. 217-02020)	Oct-15
Power sensor HP 8481A	MY41092317	07-Oct-14 (No. 217-02021)	Oct-15
Reference 20 dB Attenuator	SN: 5058 (20k)	03-Apr-14 (No. 217-01918)	Apr-15
Type-N mismatch combination	SN: 5047.2 / 06327	03-Apr-14 (No. 217-01921)	Apr-15
Reference Probe ES3DV3	SN: 3205	30-Dec-14 (No. ES3-3205_Dec14)	Dec-15
DAE4	SN: 601	18-Aug-14 (No. DAE4-601_Aug14)	Aug-15
Secondary Standards	ID #	Check Date (in house)	Scheduled Check
RF generator R&S SMT-06	100005	04-Aug-99 (in house check Oct-13)	In house check: Oct-16
Network Analyzer HP 8753E	US37390585 S4206	18-Oct-01 (in house check Oct-14)	In house check: Oct-15

Calibrated by: **Michael Weber** Name: Michael Weber Function: Laboratory Technician

Signature: *M. Weber*

Approved by: **Katja Pokovic** Name: Katja Pokovic Technical Manager

Signature: *Katja Pokovic*

Issued: January 19, 2015

This calibration certificate shall not be reproduced except in full without written approval of the laboratory.



Accredited by the Swiss Accreditation Service (SAS)

The Swiss Accreditation Service is one of the signatories to the EA Multilateral Agreement for the recognition of calibration certificates

Accreditation No.: **SCS 0108**

Glossary:

TSL	tissue simulating liquid
ConvF	sensitivity in TSL / NORM x,y,z
N/A	not applicable or not measured

Calibration is Performed According to the Following Standards:

- IEEE Std 1528-2013, "IEEE Recommended Practice for Determining the Peak Spatial-Averaged Specific Absorption Rate (SAR) in the Human Head from Wireless Communications Devices: Measurement Techniques", June 2013
- IEC 62209-1, "Procedure to measure the Specific Absorption Rate (SAR) for hand-held devices used in close proximity to the ear (frequency range of 300 MHz to 3 GHz)", February 2005
- KDB 865664, "SAR Measurement Requirements for 100 MHz to 6 GHz"

Additional Documentation:

- DASY4/5 System Handbook

Methods Applied and Interpretation of Parameters:

- Measurement Conditions:** Further details are available from the Validation Report at the end of the certificate. All figures stated in the certificate are valid at the frequency indicated.
- Antenna Parameters with TSL:** The dipole is mounted with the spacer to position its feed point exactly below the center marking of the flat phantom section, with the arms oriented parallel to the body axis.
- Feed Point Impedance and Return Loss:** These parameters are measured with the dipole positioned under the liquid filled phantom. The impedance stated is transformed from the measurement at the SMA connector to the feed point. The Return Loss ensures low reflected power. No uncertainty required.
- Electrical Delay:** One-way delay between the SMA connector and the antenna feed point. No uncertainty required.
- SAR measured:** SAR measured at the stated antenna input power.
- SAR normalized:** SAR as measured, normalized to an input power of 1 W at the antenna connector.
- SAR for nominal TSL parameters:** The measured TSL parameters are used to calculate the nominal SAR result.

The reported uncertainty of measurement is stated as the standard uncertainty of measurement multiplied by the coverage factor $k=2$, which for a normal distribution corresponds to a coverage probability of approximately 95%.

Measurement Conditions

DASY system configuration, as far as not given on page 1.

DASY Version	DASY5	V52.8.8
Extrapolation	Advanced Extrapolation	
Phantom	Modular Flat Phantom	
Distance Dipole Center - TSL	15 mm	with Spacer
Zoom Scan Resolution	dx, dy, dz = 5 mm	
Frequency	835 MHz \pm 1 MHz	

Head TSL parameters

The following parameters and calculations were applied.

	Temperature	Permittivity	Conductivity
Nominal Head TSL parameters	22.0 °C	41.5	0.90 mho/m
Measured Head TSL parameters	(22.0 \pm 0.2) °C	41.5 \pm 6 %	0.93 mho/m \pm 6 %
Head TSL temperature change during test	< 0.5 °C	----	----

SAR result with Head TSL

SAR averaged over 1 cm³ (1 g) of Head TSL	Condition	
SAR measured	250 mW input power	2.37 W/kg
SAR for nominal Head TSL parameters	normalized to 1W	9.25 W/kg \pm 17.0 % (k=2)

SAR averaged over 10 cm³ (10 g) of Head TSL	condition	
SAR measured	250 mW input power	1.54 W/kg
SAR for nominal Head TSL parameters	normalized to 1W	6.04 W/kg \pm 16.5 % (k=2)

Body TSL parameters

The following parameters and calculations were applied.

	Temperature	Permittivity	Conductivity
Nominal Body TSL parameters	22.0 °C	55.2	0.97 mho/m
Measured Body TSL parameters	(22.0 \pm 0.2) °C	55.8 \pm 6 %	1.01 mho/m \pm 6 %
Body TSL temperature change during test	< 0.5 °C	----	----

SAR result with Body TSL

SAR averaged over 1 cm³ (1 g) of Body TSL	Condition	
SAR measured	250 mW input power	2.35 W/kg
SAR for nominal Body TSL parameters	normalized to 1W	9.14 W/kg \pm 17.0 % (k=2)

SAR averaged over 10 cm³ (10 g) of Body TSL	condition	
SAR measured	250 mW input power	1.53 W/kg
SAR for nominal Body TSL parameters	normalized to 1W	5.98 W/kg \pm 16.5 % (k=2)

Appendix (Additional assessments outside the scope of SCS0108)

Antenna Parameters with Head TSL

Impedance, transformed to feed point	51.8 Ω - 2.3 j Ω
Return Loss	- 30.8 dB

Antenna Parameters with Body TSL

Impedance, transformed to feed point	47.5 Ω - 4.3 j Ω
Return Loss	- 25.9 dB

General Antenna Parameters and Design

Electrical Delay (one direction)	1.385 ns
----------------------------------	----------

After long term use with 100W radiated power, only a slight warming of the dipole near the feedpoint can be measured.

The dipole is made of standard semirigid coaxial cable. The center conductor of the feeding line is directly connected to the second arm of the dipole. The antenna is therefore short-circuited for DC-signals. On some of the dipoles, small end caps are added to the dipole arms in order to improve matching when loaded according to the position as explained in the "Measurement Conditions" paragraph. The SAR data are not affected by this change. The overall dipole length is still according to the Standard.

No excessive force must be applied to the dipole arms, because they might bend or the soldered connections near the feedpoint may be damaged.

Additional EUT Data

Manufactured by	SPEAG
Manufactured on	July 22, 2011

DASY5 Validation Report for Head TSL

Date: 16.01.2015

Test Laboratory: SPEAG, Zurich, Switzerland

DUT: Dipole 835 MHz; Type: D835V2; Serial: D835V2 - SN: 4d132

Communication System: UID 0 - CW; Frequency: 835 MHz

Medium parameters used: $f = 835$ MHz; $\sigma = 0.93$ S/m; $\epsilon_r = 41.5$; $\rho = 1000$ kg/m³

Phantom section: Flat Section

Measurement Standard: DASY5 (IEEE/IEC/ANSI C63.19-2011)

DASY52 Configuration:

- Probe: ES3DV3 - SN3205; ConvF(6.2, 6.2, 6.2); Calibrated: 30.12.2014;
- Sensor-Surface: 3mm (Mechanical Surface Detection)
- Electronics: DAE4 Sn601; Calibrated: 18.08.2014
- Phantom: Flat Phantom 4.9L; Type: QD000P49AA; Serial: 1001
- DASY52 52.8.8(1222); SEMCAD X 14.6.10(7331)

Dipole Calibration for Head Tissue/Pin=250 mW, d=15mm/Zoom Scan (7x7x7)/Cube 0:

Measurement grid: dx=5mm, dy=5mm, dz=5mm

Reference Value = 56.27 V/m; Power Drift = -0.00 dB

Peak SAR (extrapolated) = 3.51 W/kg

SAR(1 g) = 2.37 W/kg; SAR(10 g) = 1.54 W/kg

Maximum value of SAR (measured) = 2.77 W/kg

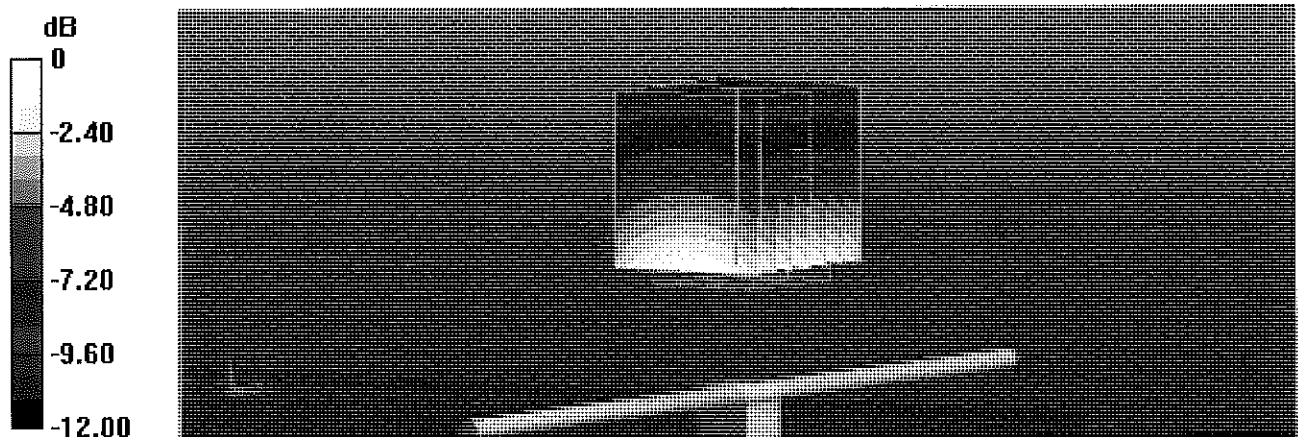

Impedance Measurement Plot for Head TSL

16 Jan 2015 16:20:53

CH1 S11 1 U FS 1: 51.828 Ω -2.2891 Ω 83.268 pF 835.000 000 MHz

*
De1
CA
Avg
16
H1d

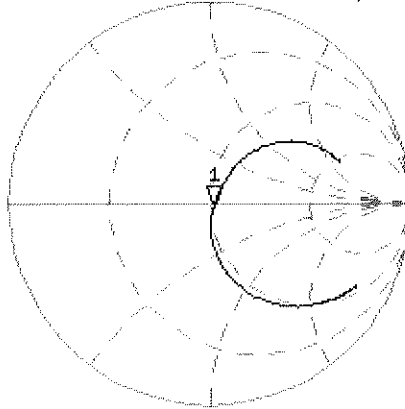

CH2 S11 LOG 5 dB/REF -20 dB 1: -30.820 dB 835.000 000 MHz

CA
Avg
16
H1d

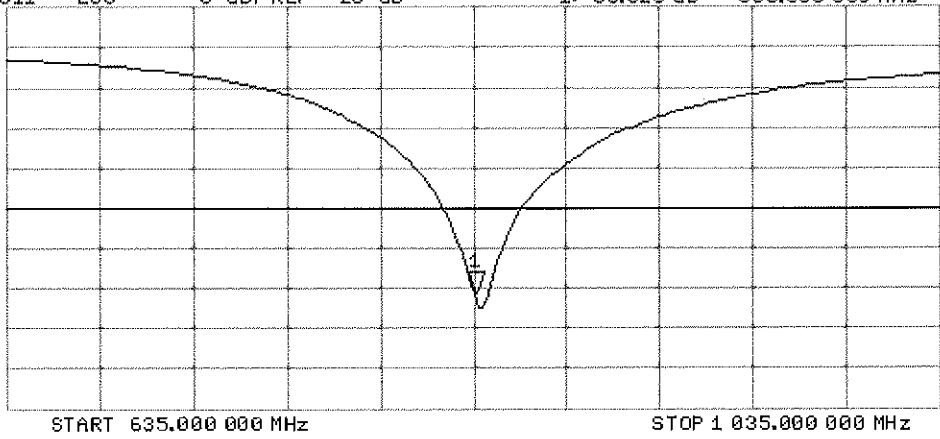

DASY5 Validation Report for Body TSL

Date: 16.01.2015

Test Laboratory: SPEAG, Zurich, Switzerland

DUT: Dipole 835 MHz; Type: D835V2; Serial: D835V2 - SN: 4d132

Communication System: UID 0 - CW; Frequency: 835 MHz

Medium parameters used: $f = 835 \text{ MHz}$; $\sigma = 1.01 \text{ S/m}$; $\epsilon_r = 55.8$; $\rho = 1000 \text{ kg/m}^3$

Phantom section: Flat Section

Measurement Standard: DASY5 (IEEE/IEC/ANSI C63.19-2011)

DASY52 Configuration:

- Probe: ES3DV3 - SN3205; ConvF(6.17, 6.17, 6.17); Calibrated: 30.12.2014;
- Sensor-Surface: 3mm (Mechanical Surface Detection)
- Electronics: DAE4 Sn601; Calibrated: 18.08.2014
- Phantom: Flat Phantom 4.9L; Type: QD000P49AA; Serial: 1001
- DASY52 52.8.8(1222); SEMCAD X 14.6.10(7331)

Dipole Calibration for Body Tissue/Pin=250 mW, d=15mm/Zoom Scan (7x7x7)/Cube 0:

Measurement grid: $dx=5\text{mm}$, $dy=5\text{mm}$, $dz=5\text{mm}$

Reference Value = 54.27 V/m; Power Drift = -0.03 dB

Peak SAR (extrapolated) = 3.47 W/kg

SAR(1 g) = 2.35 W/kg; SAR(10 g) = 1.53 W/kg

Maximum value of SAR (measured) = 2.75 W/kg

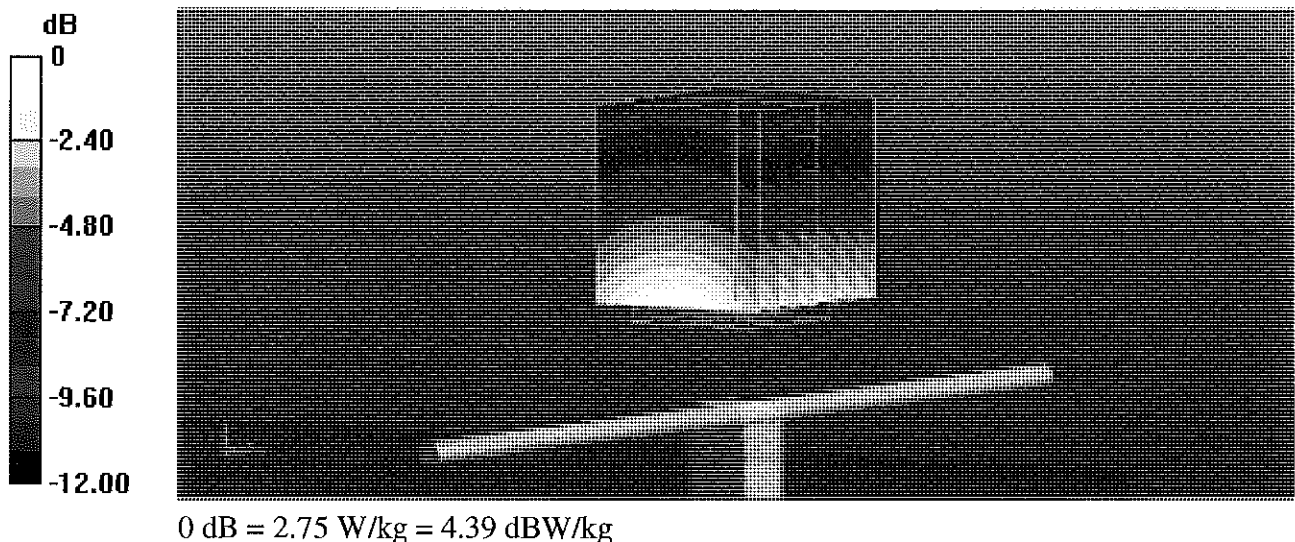

Impedance Measurement Plot for Body TSL

16 Jan 2015 13:51:19

CH1 S11 1 U FS

1: 47.498 Ω -4.2520 Ω 44.828 μ F 835.000 000 MHz

*
De1
CA

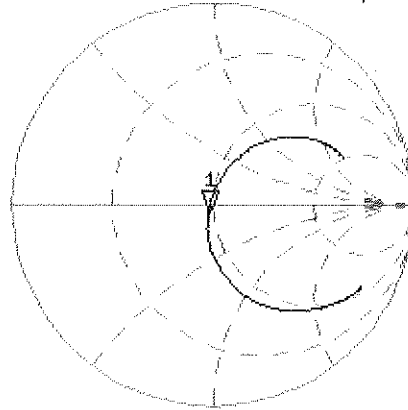

Avg
16

H1d

CH2 S11 LOG 5 dB/REF -20 dB 1:-25.931 dB 835.000 000 MHz

CA

Avg
16

H1d

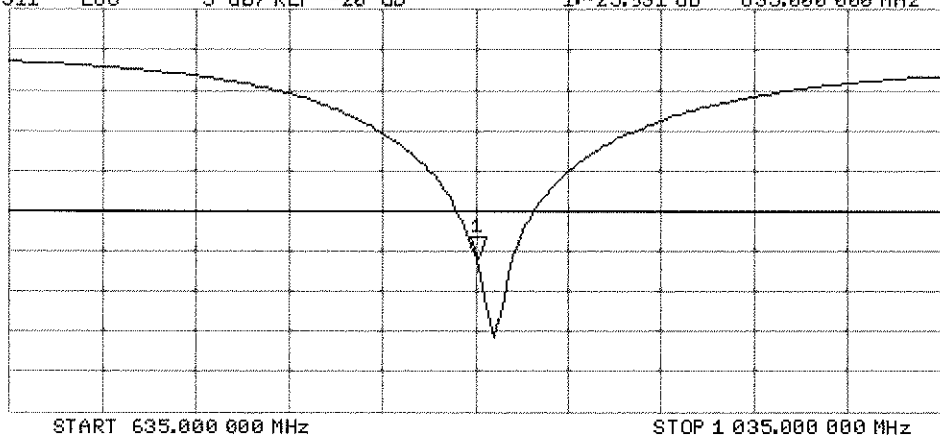



Accredited by the Swiss Accreditation Service (SAS)
The Swiss Accreditation Service is one of the signatories to the EA
Multilateral Agreement for the recognition of calibration certificates

Accreditation No.: **SCS 0108**

Client **PC Test**

Certificate No: **D2450V2-882_Feb15**

CALIBRATION CERTIFICATE

Object **D2450V2 - SN:882**

Calibration procedure(s) **QA CAL-05.v9
Calibration procedure for dipole validation kits above 700 MHz**

Calibration date: **February 18, 2015**

PTV
3/6/15

This calibration certificate documents the traceability to national standards, which realize the physical units of measurements (SI).
The measurements and the uncertainties with confidence probability are given on the following pages and are part of the certificate.

All calibrations have been conducted in the closed laboratory facility: environment temperature (22 ± 3)°C and humidity < 70%.

Calibration Equipment used (M&TE critical for calibration)

Primary Standards	ID #	Cal Date (Certificate No.)	Scheduled Calibration
Power meter EPM-442A	GB37480704	07-Oct-14 (No. 217-02020)	Oct-15
Power sensor HP 8481A	US37292783	07-Oct-14 (No. 217-02020)	Oct-15
Power sensor HP 8481A	MY41092317	07-Oct-14 (No. 217-02021)	Oct-15
Reference 20 dB Attenuator	SN: 5058 (20k)	03-Apr-14 (No. 217-01918)	Apr-15
Type-N mismatch combination	SN: 5047.2 / 06327	03-Apr-14 (No. 217-01921)	Apr-15
Reference Probe ES3DV3	SN: 3205	30-Dec-14 (No. ES3-3205_Dec14)	Dec-15
DAE4	SN: 601	18-Aug-14 (No. DAE4-601_Aug14)	Aug-15
Secondary Standards	ID #	Check Date (in house)	Scheduled Check
RF generator R&S SMT-06	100005	04-Aug-99 (in house check Oct-13)	In house check: Oct-16
Network Analyzer HP 8753E	US37390585 S4206	18-Oct-01 (in house check Oct-14)	In house check: Oct-15

Calibrated by: **Michael Weber** Name: Michael Weber Function: Laboratory Technician

Signature: *[Handwritten Signature]*

Approved by: **Katja Pokovic** Name: Katja Pokovic Function: Technical Manager

Signature: *[Handwritten Signature]*

Issued: February 18, 2015

This calibration certificate shall not be reproduced except in full without written approval of the laboratory.



Accreditation No.: **SCS 0108**

Accredited by the Swiss Accreditation Service (SAS)

The Swiss Accreditation Service is one of the signatories to the EA
Multilateral Agreement for the recognition of calibration certificates

Glossary:

TSL	tissue simulating liquid
ConvF	sensitivity in TSL / NORM x,y,z
N/A	not applicable or not measured

Calibration is Performed According to the Following Standards:

- IEEE Std 1528-2013, "IEEE Recommended Practice for Determining the Peak Spatial-Averaged Specific Absorption Rate (SAR) in the Human Head from Wireless Communications Devices: Measurement Techniques", June 2013
- IEC 62209-1, "Procedure to measure the Specific Absorption Rate (SAR) for hand-held devices used in close proximity to the ear (frequency range of 300 MHz to 3 GHz)", February 2005
- KDB 865664, "SAR Measurement Requirements for 100 MHz to 6 GHz"

Additional Documentation:

- DASY4/5 System Handbook

Methods Applied and Interpretation of Parameters:

- Measurement Conditions:* Further details are available from the Validation Report at the end of the certificate. All figures stated in the certificate are valid at the frequency indicated.
- Antenna Parameters with TSL:* The dipole is mounted with the spacer to position its feed point exactly below the center marking of the flat phantom section, with the arms oriented parallel to the body axis.
- Feed Point Impedance and Return Loss:* These parameters are measured with the dipole positioned under the liquid filled phantom. The impedance stated is transformed from the measurement at the SMA connector to the feed point. The Return Loss ensures low reflected power. No uncertainty required.
- Electrical Delay:* One-way delay between the SMA connector and the antenna feed point. No uncertainty required.
- SAR measured:* SAR measured at the stated antenna input power.
- SAR normalized:* SAR as measured, normalized to an input power of 1 W at the antenna connector.
- SAR for nominal TSL parameters:* The measured TSL parameters are used to calculate the nominal SAR result.

The reported uncertainty of measurement is stated as the standard uncertainty of measurement multiplied by the coverage factor $k=2$, which for a normal distribution corresponds to a coverage probability of approximately 95%.

Measurement Conditions

DASY system configuration, as far as not given on page 1.

DASY Version	DASY5	V52.8.8
Extrapolation	Advanced Extrapolation	
Phantom	Modular Flat Phantom	
Distance Dipole Center - TSL	10 mm	with Spacer
Zoom Scan Resolution	dx, dy, dz = 5 mm	
Frequency	2450 MHz \pm 1 MHz	

Head TSL parameters

The following parameters and calculations were applied.

	Temperature	Permittivity	Conductivity
Nominal Head TSL parameters	22.0 °C	39.2	1.80 mho/m
Measured Head TSL parameters	(22.0 \pm 0.2) °C	38.2 \pm 6 %	1.87 mho/m \pm 6 %
Head TSL temperature change during test	< 0.5 °C	----	----

SAR result with Head TSL

SAR averaged over 1 cm³ (1 g) of Head TSL	Condition	
SAR measured	250 mW input power	13.4 W/kg
SAR for nominal Head TSL parameters	normalized to 1W	52.3 W/kg \pm 17.0 % (k=2)

SAR averaged over 10 cm³ (10 g) of Head TSL	condition	
SAR measured	250 mW input power	6.16 W/kg
SAR for nominal Head TSL parameters	normalized to 1W	24.3 W/kg \pm 16.5 % (k=2)

Body TSL parameters

The following parameters and calculations were applied.

	Temperature	Permittivity	Conductivity
Nominal Body TSL parameters	22.0 °C	52.7	1.95 mho/m
Measured Body TSL parameters	(22.0 \pm 0.2) °C	51.7 \pm 6 %	2.04 mho/m \pm 6 %
Body TSL temperature change during test	< 0.5 °C	----	----

SAR result with Body TSL

SAR averaged over 1 cm³ (1 g) of Body TSL	Condition	
SAR measured	250 mW input power	13.0 W/kg
SAR for nominal Body TSL parameters	normalized to 1W	50.7 W/kg \pm 17.0 % (k=2)

SAR averaged over 10 cm³ (10 g) of Body TSL	condition	
SAR measured	250 mW input power	5.97 W/kg
SAR for nominal Body TSL parameters	normalized to 1W	23.5 W/kg \pm 16.5 % (k=2)

Appendix (Additional assessments outside the scope of SCS0108)

Antenna Parameters with Head TSL

Impedance, transformed to feed point	52.8 Ω - 0.2 j Ω
Return Loss	- 31.2 dB

Antenna Parameters with Body TSL

Impedance, transformed to feed point	50.4 Ω + 1.9 j Ω
Return Loss	- 34.4 dB

General Antenna Parameters and Design

Electrical Delay (one direction)	1.156 ns
----------------------------------	----------

After long term use with 100W radiated power, only a slight warming of the dipole near the feedpoint can be measured.

The dipole is made of standard semirigid coaxial cable. The center conductor of the feeding line is directly connected to the second arm of the dipole. The antenna is therefore short-circuited for DC-signals. On some of the dipoles, small end caps are added to the dipole arms in order to improve matching when loaded according to the position as explained in the "Measurement Conditions" paragraph. The SAR data are not affected by this change. The overall dipole length is still according to the Standard.

No excessive force must be applied to the dipole arms, because they might bend or the soldered connections near the feedpoint may be damaged.

Additional EUT Data

Manufactured by	SPEAG
Manufactured on	October 06, 2011

DASY5 Validation Report for Head TSL

Date: 18.02.2015

Test Laboratory: SPEAG, Zurich, Switzerland

DUT: Dipole 2450 MHz; Type: D2450V2; Serial: D2450V2 - SN:882

Communication System: UID 0 - CW; Frequency: 2450 MHz

Medium parameters used: $f = 2450$ MHz; $\sigma = 1.87$ S/m; $\epsilon_r = 38.2$; $\rho = 1000$ kg/m³

Phantom section: Flat Section

Measurement Standard: DASY5 (IEEE/IEC/ANSI C63.19-2011)

DASY52 Configuration:

- Probe: ES3DV3 - SN3205; ConvF(4.54, 4.54, 4.54); Calibrated: 30.12.2014;
- Sensor-Surface: 3mm (Mechanical Surface Detection)
- Electronics: DAE4 Sn601; Calibrated: 18.08.2014
- Phantom: Flat Phantom 5.0 (front); Type: QD000P50AA; Serial: 1001
- DASY52 52.8.8(1222); SEMCAD X 14.6.10(7331)

Dipole Calibration for Head Tissue - ES Probe/Pin=250 mW, d=10mm/Zoom Scan

(7x7x7)/Cube 0: Measurement grid: dx=5mm, dy=5mm, dz=5mm

Reference Value = 99.95 V/m; Power Drift = 0.03 dB

Peak SAR (extrapolated) = 27.9 W/kg

SAR(1 g) = 13.4 W/kg; SAR(10 g) = 6.16 W/kg

Maximum value of SAR (measured) = 17.3 W/kg

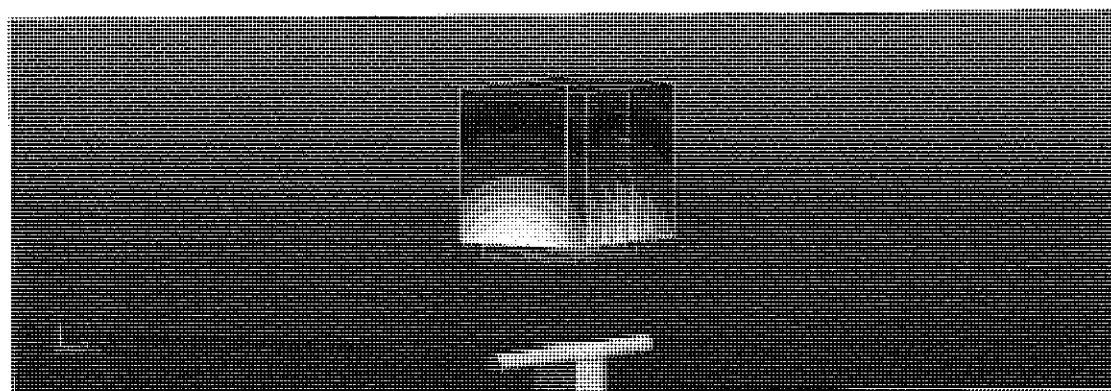
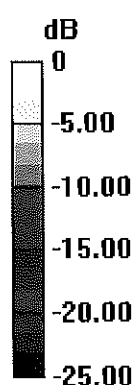

0 dB = 17.3 W/kg = 12.38 dBW/kg

Impedance Measurement Plot for Head TSL

18 Feb 2015 11:27:18

CH1 S11 1 U FS 1: 52.885 Δ -212.89 m Δ 305.14 pF 2 450.000 000 MHz

*
De1
C Δ

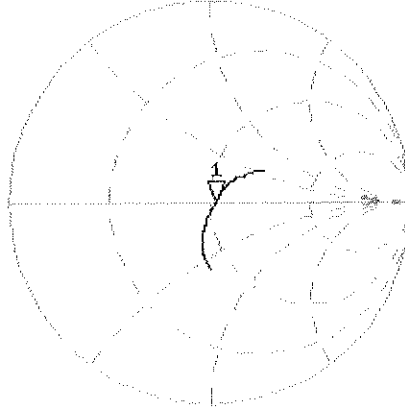

Avg
16

H1d

CH2 S11 LOG 5 dB/REF -20 dB 1: -31.245 dB 2 450.000 000 MHz

C Δ

Avg
16

H1d

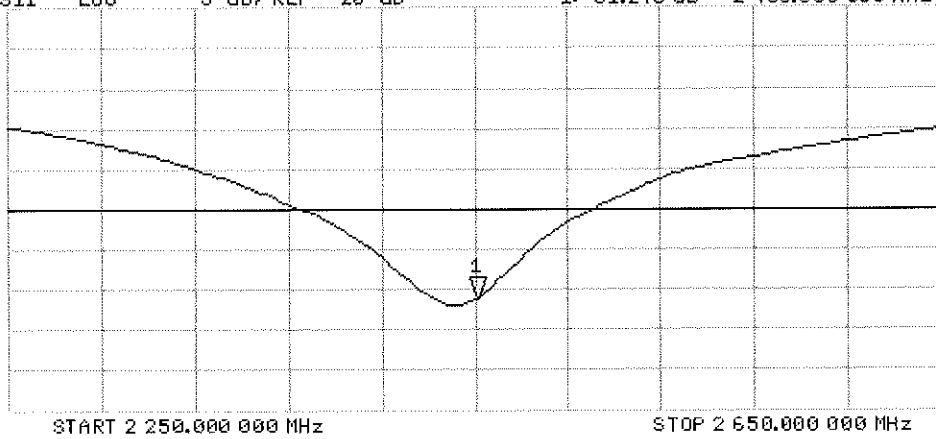

DASY5 Validation Report for Body TSL

Date: 18.02.2015

Test Laboratory: SPEAG, Zurich, Switzerland

DUT: Dipole 2450 MHz; Type: D2450V2; Serial: D2450V2 - SN:882

Communication System: UID 0 - CW; Frequency: 2450 MHz

Medium parameters used: $f = 2450$ MHz; $\sigma = 2.04$ S/m; $\epsilon_r = 51.7$; $\rho = 1000$ kg/m³

Phantom section: Flat Section

Measurement Standard: DASY5 (IEEE/IEC/ANSI C63.19-2011)

DASY52 Configuration:

- Probe: ES3DV3 - SN3205; ConvF(4.32, 4.32, 4.32); Calibrated: 30.12.2014;
- Sensor-Surface: 3mm (Mechanical Surface Detection)
- Electronics: DAE4 Sn601; Calibrated: 18.08.2014
- Phantom: Flat Phantom 5.0 (back); Type: QD000P50AA; Serial: 1002
- DASY52 52.8.8(1222); SEMCAD X 14.6.10(7331)

Dipole Calibration for Body Tissue - ES Probe/Pin=250 mW, d=10mm/Zoom Scan

(7x7x7)/Cube 0: Measurement grid: dx=5mm, dy=5mm, dz=5mm

Reference Value = 94.16 V/m; Power Drift = 0.02 dB

Peak SAR (extrapolated) = 27.2 W/kg

SAR(1 g) = 13 W/kg; SAR(10 g) = 5.97 W/kg

Maximum value of SAR (measured) = 17.0 W/kg

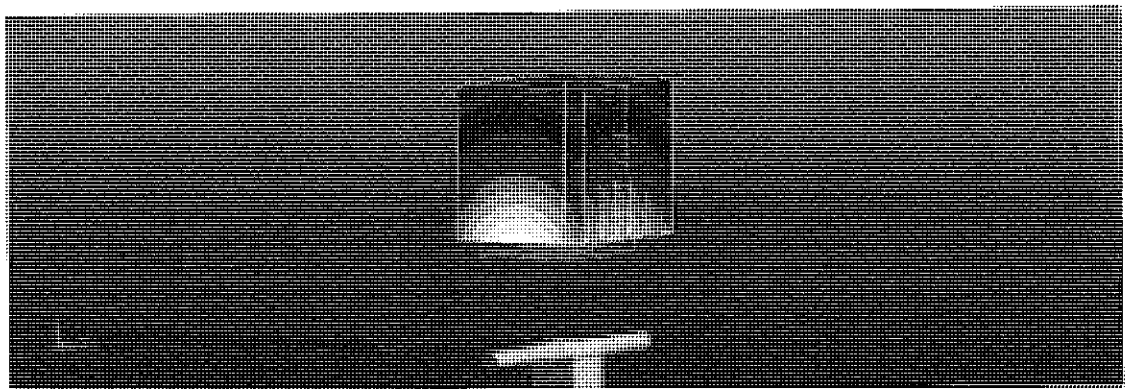
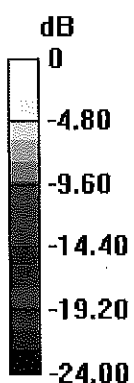

0 dB = 17.0 W/kg = 12.30 dBW/kg

Impedance Measurement Plot for Body TSL

18 Feb 2015 11:26:48

CH1 S11 1 U FS 1: 50.354 Δ 1.8009 Δ 122.18 μ H 2 450.000 000 MHz

*
De1
C Δ

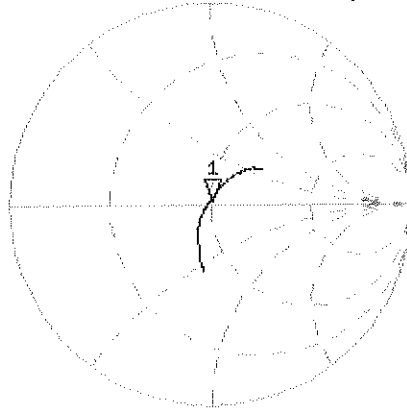

Avg
15

H1d

CH2 S11 LOG 5 dB/REF -20 dB 1: -34.367 dB 2 450.000 000 MHz

C Δ

Avg
15

H1d

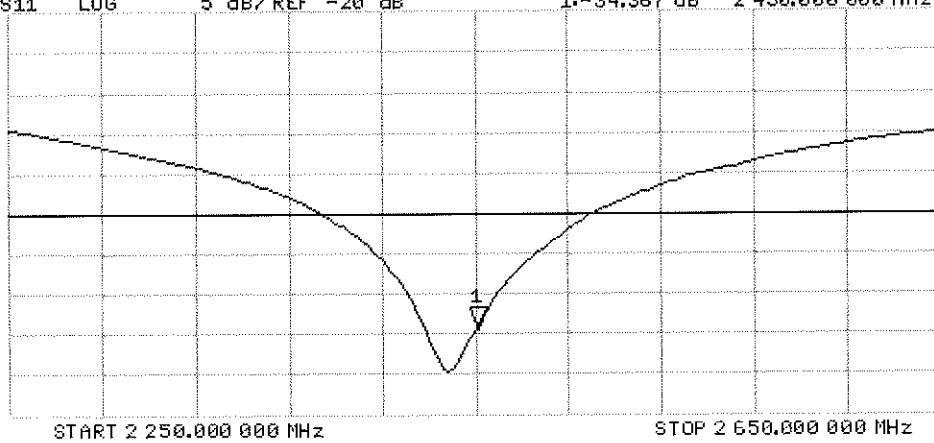



Accredited by the Swiss Accreditation Service (SAS)
The Swiss Accreditation Service is one of the signatories to the EA
Multilateral Agreement for the recognition of calibration certificates

Accreditation No.: **SCS 108**

Client **PC Test**

Certificate No: **D5GHzV2-1191_Sep14**

CALIBRATION CERTIFICATE

Object **D5GHzV2 - SN:1191**

Calibration procedure(s) **QA CAL-22.v2
Calibration procedure for dipole validation kits between 3-6 GHz**

*CC
11/14*

Calibration date: **September 25, 2014**

This calibration certificate documents the traceability to national standards, which realize the physical units of measurements (SI).
The measurements and the uncertainties with confidence probability are given on the following pages and are part of the certificate.

All calibrations have been conducted in the closed laboratory facility: environment temperature (22 ± 3)°C and humidity < 70%.

Calibration Equipment used (M&TE critical for calibration)

Primary Standards	ID #	Cal Date (Certificate No.)	Scheduled Calibration
Power meter EPM-442A	GB37480704	09-Oct-13 (No. 217-01827)	Oct-14
Power sensor HP 8481A	US37292783	09-Oct-13 (No. 217-01827)	Oct-14
Power sensor HP 8481A	MY41092317	09-Oct-13 (No. 217-01828)	Oct-14
Reference 20 dB Attenuator	SN: 5058 (20k)	03-Apr-14 (No. 217-01918)	Apr-15
Type-N mismatch combination	SN: 5047.2 / 06327	03-Apr-14 (No. 217-01921)	Apr-15
Reference Probe EX3DV4	SN: 3503	30-Dec-13 (No. EX3-3503_Dec13)	Dec-14
DAE4	SN: 601	18-Aug-14 (No. DAE4-601_Aug14)	Aug-15
Secondary Standards	ID #	Check Date (in house)	Scheduled Check
RF generator R&S SMT-06	100005	04-Aug-99 (in house check Oct-13)	In house check: Oct-16
Network Analyzer HP 8753E	US37390585 S4206	18-Oct-01 (in house check Oct-13)	In house check: Oct-14

Calibrated by: **Claudio Leubler** Name: Claudio Leubler Function: Laboratory Technician

Signature

Approved by: **Katja Pokovic** Name: Katja Pokovic Technical Manager

Issued: September 25, 2014

This calibration certificate shall not be reproduced except in full without written approval of the laboratory.

**Calibration Laboratory of
Schmid & Partner
Engineering AG**
Zeughausstrasse 43, 8004 Zurich, Switzerland



S Schweizerischer Kalibrierdienst
C Service suisse d'étalonnage
S Servizio svizzero di taratura
S Swiss Calibration Service

Accreditation No.: **SCS 108**

Accredited by the Swiss Accreditation Service (SAS)
The Swiss Accreditation Service is one of the signatories to the EA
Multilateral Agreement for the recognition of calibration certificates

Glossary:

TSL	tissue simulating liquid
ConvF	sensitivity in TSL / NORM x,y,z
N/A	not applicable or not measured

Calibration is Performed According to the Following Standards:

- IEC 62209-2, "Evaluation of Human Exposure to Radio Frequency Fields from Handheld and Body-Mounted Wireless Communication Devices in the Frequency Range of 30 MHz to 6 GHz: Human models, Instrumentation, and Procedures"; Part 2: "Procedure to determine the Specific Absorption Rate (SAR) for including accessories and multiple transmitters", March 2010
- KDB 865664, "SAR Measurement Requirements for 100 MHz to 6 GHz"
- IEEE Std 1528-2013, "IEEE Recommended Practice for Determining the Peak Spatial-Averaged Specific Absorption Rate (SAR) in the Human Head from Wireless Communications Devices: Measurement Techniques", June 2013

Additional Documentation:

- DASY4/5 System Handbook

Methods Applied and Interpretation of Parameters:

- Measurement Conditions:* Further details are available from the Validation Report at the end of the certificate. All figures stated in the certificate are valid at the frequency indicated.
- Antenna Parameters with TSL:* The dipole is mounted with the spacer to position its feed point exactly below the center marking of the flat phantom section, with the arms oriented parallel to the body axis.
- Feed Point Impedance and Return Loss:* These parameters are measured with the dipole positioned under the liquid filled phantom. The impedance stated is transformed from the measurement at the SMA connector to the feed point. The Return Loss ensures low reflected power. No uncertainty required.
- Electrical Delay:* One-way delay between the SMA connector and the antenna feed point. No uncertainty required.
- SAR measured:* SAR measured at the stated antenna input power.
- SAR normalized:* SAR as measured, normalized to an input power of 1 W at the antenna connector.
- SAR for nominal TSL parameters:* The measured TSL parameters are used to calculate the nominal SAR result.

The reported uncertainty of measurement is stated as the standard uncertainty of measurement multiplied by the coverage factor $k=2$, which for a normal distribution corresponds to a coverage probability of approximately 95%.

Measurement Conditions

DASY system configuration, as far as not given on page 1.

DASY Version	DASY5	V52.8.8
Extrapolation	Advanced Extrapolation	
Phantom	Modular Flat Phantom V5.0	
Distance Dipole Center - TSL	10 mm	with Spacer
Zoom Scan Resolution	dx, dy = 4.0 mm, dz = 1.4 mm	Graded Ratio = 1.4 (Z direction)
Frequency	5200 MHz ± 1 MHz 5300 MHz ± 1 MHz 5500 MHz ± 1 MHz 5600 MHz ± 1 MHz 5800 MHz ± 1 MHz	

Head TSL parameters at 5200 MHz

The following parameters and calculations were applied.

	Temperature	Permittivity	Conductivity
Nominal Head TSL parameters	22.0 °C	36.0	4.66 mho/m
Measured Head TSL parameters	(22.0 ± 0.2) °C	34.9 ± 6 %	4.54 mho/m ± 6 %
Head TSL temperature change during test	< 0.5 °C	----	----

SAR result with Head TSL at 5200 MHz

SAR averaged over 1 cm ³ (1 g) of Head TSL	Condition	
SAR measured	100 mW input power	8.17 W/kg
SAR for nominal Head TSL parameters	normalized to 1W	81.1 W/kg ± 19.9 % (k=2)

SAR averaged over 10 cm ³ (10 g) of Head TSL	condition	
SAR measured	100 mW input power	2.33 W/kg
SAR for nominal Head TSL parameters	normalized to 1W	23.1 W/kg ± 19.5 % (k=2)

Head TSL parameters at 5300 MHz

The following parameters and calculations were applied.

	Temperature	Permittivity	Conductivity
Nominal Head TSL parameters	22.0 °C	35.9	4.76 mho/m
Measured Head TSL parameters	(22.0 ± 0.2) °C	34.8 ± 6 %	4.64 mho/m ± 6 %
Head TSL temperature change during test	< 0.5 °C	----	----

SAR result with Head TSL at 5300 MHz

SAR averaged over 1 cm ³ (1 g) of Head TSL	Condition	
SAR measured	100 mW input power	8.64 W/kg
SAR for nominal Head TSL parameters	normalized to 1W	85.8 W / kg ± 19.9 % (k=2)

SAR averaged over 10 cm ³ (10 g) of Head TSL	condition	
SAR measured	100 mW input power	2.47 W/kg
SAR for nominal Head TSL parameters	normalized to 1W	24.5 W/kg ± 19.5 % (k=2)

Head TSL parameters at 5500 MHz

The following parameters and calculations were applied.

	Temperature	Permittivity	Conductivity
Nominal Head TSL parameters	22.0 °C	35.6	4.96 mho/m
Measured Head TSL parameters	(22.0 ± 0.2) °C	34.5 ± 6 %	4.83 mho/m ± 6 %
Head TSL temperature change during test	< 0.5 °C	----	----

SAR result with Head TSL at 5500 MHz

SAR averaged over 1 cm ³ (1 g) of Head TSL	Condition	
SAR measured	100 mW input power	8.93 W/kg
SAR for nominal Head TSL parameters	normalized to 1W	88.6 W/kg ± 19.9 % (k=2)

SAR averaged over 10 cm ³ (10 g) of Head TSL	condition	
SAR measured	100 mW input power	2.54 W/kg
SAR for nominal Head TSL parameters	normalized to 1W	25.2 W/kg ± 19.5 % (k=2)

Head TSL parameters at 5600 MHz

The following parameters and calculations were applied.

	Temperature	Permittivity	Conductivity
Nominal Head TSL parameters	22.0 °C	35.5	5.07 mho/m
Measured Head TSL parameters	(22.0 ± 0.2) °C	34.4 ± 6 %	4.93 mho/m ± 6 %
Head TSL temperature change during test	< 0.5 °C	----	----

SAR result with Head TSL at 5600 MHz

SAR averaged over 1 cm ³ (1 g) of Head TSL	Condition	
SAR measured	100 mW input power	8.76 W/kg
SAR for nominal Head TSL parameters	normalized to 1W	86.9 W/kg ± 19.9 % (k=2)

SAR averaged over 10 cm ³ (10 g) of Head TSL	condition	
SAR measured	100 mW input power	2.49 W/kg
SAR for nominal Head TSL parameters	normalized to 1W	24.7 W/kg ± 19.5 % (k=2)

Head TSL parameters at 5800 MHz

The following parameters and calculations were applied.

	Temperature	Permittivity	Conductivity
Nominal Head TSL parameters	22.0 °C	35.3	5.27 mho/m
Measured Head TSL parameters	(22.0 ± 0.2) °C	34.1 ± 6 %	5.14 mho/m ± 6 %
Head TSL temperature change during test	< 0.5 °C	----	----

SAR result with Head TSL at 5800 MHz

SAR averaged over 1 cm ³ (1 g) of Head TSL	Condition	
SAR measured	100 mW input power	8.30 W/kg
SAR for nominal Head TSL parameters	normalized to 1W	82.3 W/kg ± 19.9 % (k=2)

SAR averaged over 10 cm ³ (10 g) of Head TSL	condition	
SAR measured	100 mW input power	2.35 W/kg
SAR for nominal Head TSL parameters	normalized to 1W	23.3 W/kg ± 19.5 % (k=2)

Body TSL parameters at 5200 MHz

The following parameters and calculations were applied.

	Temperature	Permittivity	Conductivity
Nominal Body TSL parameters	22.0 °C	49.0	5.30 mho/m
Measured Body TSL parameters	(22.0 ± 0.2) °C	47.1 ± 6 %	5.40 mho/m ± 6 %
Body TSL temperature change during test	< 0.5 °C	----	----

SAR result with Body TSL at 5200 MHz

SAR averaged over 1 cm ³ (1 g) of Body TSL	Condition	
SAR measured	100 mW input power	7.84 W/kg
SAR for nominal Body TSL parameters	normalized to 1W	77.8 W/kg ± 19.9 % (k=2)

SAR averaged over 10 cm ³ (10 g) of Body TSL	condition	
SAR measured	100 mW input power	2.18 W/kg
SAR for nominal Body TSL parameters	normalized to 1W	21.6 W/kg ± 19.5 % (k=2)

Body TSL parameters at 5300 MHz

The following parameters and calculations were applied.

	Temperature	Permittivity	Conductivity
Nominal Body TSL parameters	22.0 °C	48.9	5.42 mho/m
Measured Body TSL parameters	(22.0 ± 0.2) °C	46.9 ± 6 %	5.53 mho/m ± 6 %
Body TSL temperature change during test	< 0.5 °C	----	----

SAR result with Body TSL at 5300 MHz

SAR averaged over 1 cm ³ (1 g) of Body TSL	Condition	
SAR measured	100 mW input power	8.05 W/kg
SAR for nominal Body TSL parameters	normalized to 1W	79.9 W/kg ± 19.9 % (k=2)

SAR averaged over 10 cm ³ (10 g) of Body TSL	condition	
SAR measured	100 mW input power	2.25 W/kg
SAR for nominal Body TSL parameters	normalized to 1W	22.3 W/kg ± 19.5 % (k=2)

Body TSL parameters at 5500 MHz

The following parameters and calculations were applied.

	Temperature	Permittivity	Conductivity
Nominal Body TSL parameters	22.0 °C	48.6	5.65 mho/m
Measured Body TSL parameters	(22.0 ± 0.2) °C	46.6 ± 6 %	5.79 mho/m ± 6 %
Body TSL temperature change during test	< 0.5 °C	----	----

SAR result with Body TSL at 5500 MHz

SAR averaged over 1 cm ³ (1 g) of Body TSL	Condition	
SAR measured	100 mW input power	8.37 W/kg
SAR for nominal Body TSL parameters	normalized to 1W	83.1 W/kg ± 19.9 % (k=2)

SAR averaged over 10 cm ³ (10 g) of Body TSL	condition	
SAR measured	100 mW input power	2.32 W/kg
SAR for nominal Body TSL parameters	normalized to 1W	23.0 W/kg ± 19.5 % (k=2)

Body TSL parameters at 5600 MHz

The following parameters and calculations were applied.

	Temperature	Permittivity	Conductivity
Nominal Body TSL parameters	22.0 °C	48.5	5.77 mho/m
Measured Body TSL parameters	(22.0 ± 0.2) °C	46.4 ± 6 %	5.93 mho/m ± 6 %
Body TSL temperature change during test	< 0.5 °C	----	----

SAR result with Body TSL at 5600 MHz

SAR averaged over 1 cm ³ (1 g) of Body TSL	Condition	
SAR measured	100 mW input power	8.48 W/kg
SAR for nominal Body TSL parameters	normalized to 1W	84.1 W/kg ± 19.9 % (k=2)

SAR averaged over 10 cm ³ (10 g) of Body TSL	condition	
SAR measured	100 mW input power	2.35 W/kg
SAR for nominal Body TSL parameters	normalized to 1W	23.3 W/kg ± 19.5 % (k=2)

Body TSL parameters at 5800 MHz

The following parameters and calculations were applied.

	Temperature	Permittivity	Conductivity
Nominal Body TSL parameters	22.0 °C	48.2	6.00 mho/m
Measured Body TSL parameters	(22.0 ± 0.2) °C	46.1 ± 6 %	6.21 mho/m ± 6 %
Body TSL temperature change during test	< 0.5 °C	----	----

SAR result with Body TSL at 5800 MHz

SAR averaged over 1 cm ³ (1 g) of Body TSL	Condition	
SAR measured	100 mW input power	7.86 W/kg
SAR for nominal Body TSL parameters	normalized to 1W	78.0 W/kg ± 19.9 % (k=2)

SAR averaged over 10 cm ³ (10 g) of Body TSL	condition	
SAR measured	100 mW input power	2.17 W/kg
SAR for nominal Body TSL parameters	normalized to 1W	21.5 W/kg ± 19.5 % (k=2)

Appendix (Additional assessments outside the scope of SCS108)

Antenna Parameters with Head TSL at 5200 MHz

Impedance, transformed to feed point	51.8 Ω - 9.9 j Ω
Return Loss	- 20.1 dB

Antenna Parameters with Head TSL at 5300 MHz

Impedance, transformed to feed point	54.5 Ω - 1.5 j Ω
Return Loss	- 26.8 dB

Antenna Parameters with Head TSL at 5500 MHz

Impedance, transformed to feed point	49.6 Ω - 2.0 j Ω
Return Loss	- 33.9 dB

Antenna Parameters with Head TSL at 5600 MHz

Impedance, transformed to feed point	56.5 Ω - 4.4 j Ω
Return Loss	- 22.7 dB

Antenna Parameters with Head TSL at 5800 MHz

Impedance, transformed to feed point	56.6 Ω + 4.4 j Ω
Return Loss	- 22.6 dB

Antenna Parameters with Body TSL at 5200 MHz

Impedance, transformed to feed point	51.9 Ω - 8.1 j Ω
Return Loss	- 21.8 dB

Antenna Parameters with Body TSL at 5300 MHz

Impedance, transformed to feed point	54.5 Ω + 0.1 j Ω
Return Loss	- 27.3 dB

Antenna Parameters with Body TSL at 5500 MHz

Impedance, transformed to feed point	50.2 Ω - 0.6 j Ω
Return Loss	- 43.8 dB

Antenna Parameters with Body TSL at 5600 MHz

Impedance, transformed to feed point	57.5 Ω - 3.2 j Ω
Return Loss	- 22.4 dB

Antenna Parameters with Body TSL at 5800 MHz

Impedance, transformed to feed point	57.2 Ω + 5.2 j Ω
Return Loss	- 21.7 dB

General Antenna Parameters and Design

Electrical Delay (one direction)	1.202 ns
----------------------------------	----------

After long term use with 100W radiated power, only a slight warming of the dipole near the feedpoint can be measured.

The dipole is made of standard semirigid coaxial cable. The center conductor of the feeding line is directly connected to the second arm of the dipole. The antenna is therefore short-circuited for DC-signals. On some of the dipoles, small end caps are added to the dipole arms in order to improve matching when loaded according to the position as explained in the "Measurement Conditions" paragraph. The SAR data are not affected by this change. The overall dipole length is still according to the Standard.

No excessive force must be applied to the dipole arms, because they might bend or the soldered connections near the feedpoint may be damaged.

Additional EUT Data

Manufactured by	SPEAG
Manufactured on	April 01, 2014

DASY5 Validation Report for Head TSL

Date: 25.09.2014

Test Laboratory: SPEAG, Zurich, Switzerland

DUT: Dipole 5GHz; Type: D5GHzV2; Serial: D5GHzV2 - SN:1191

Communication System: UID 0 - CW; Frequency: 5200 MHz, Frequency: 5300 MHz, Frequency: 5500 MHz, Frequency: 5600 MHz, Frequency: 5800 MHz

Medium parameters used: $f = 5200$ MHz; $\sigma = 4.54$ S/m; $\epsilon_r = 34.9$; $\rho = 1000$ kg/m³

Medium parameters used: $f = 5300$ MHz; $\sigma = 4.64$ S/m; $\epsilon_r = 34.8$; $\rho = 1000$ kg/m³

Medium parameters used: $f = 5500$ MHz; $\sigma = 4.83$ S/m; $\epsilon_r = 34.5$; $\rho = 1000$ kg/m³

Medium parameters used: $f = 5600$ MHz; $\sigma = 4.93$ S/m; $\epsilon_r = 34.4$; $\rho = 1000$ kg/m³

Medium parameters used: $f = 5800$ MHz; $\sigma = 5.14$ S/m; $\epsilon_r = 34.1$; $\rho = 1000$ kg/m³

Phantom section: Flat Section

Measurement Standard: DASY5 (IBEE/IEC/ANSI C63.19-2011)

DASY52 Configuration:

- Probe: EX3DV4 - SN3503; ConvF(5.52, 5.52, 5.52); Calibrated: 30.12.2013, ConvF(5.2, 5.2, 5.2); Calibrated: 30.12.2013, ConvF(5.01, 5.01, 5.01); Calibrated: 30.12.2013, ConvF(4.86, 4.86, 4.86); Calibrated: 30.12.2013, ConvF(4.91, 4.91, 4.91); Calibrated: 30.12.2013;
- Sensor-Surface: 1.4mm (Mechanical Surface Detection)
- Electronics: DAE4 Sn601; Calibrated: 18.08.2014
- Phantom: Flat Phantom 5.0 (front); Type: QD000P50AA; Serial: 1001
- DASY52 52.8.8(1222); SEMCAD X 14.6.10(7331)

Dipole Calibration for Head Tissue/Pin=100mW, dist=10mm, f=5200 MHz/Zoom Scan,

dist=1.4mm (8x8x7)/Cube 0: Measurement grid: dx=4mm, dy=4mm, dz=1.4mm

Reference Value = 65.20 V/m; Power Drift = 0.04 dB

Peak SAR (extrapolated) = 30.0 W/kg

SAR(1 g) = 8.17 W/kg; SAR(10 g) = 2.33 W/kg

Maximum value of SAR (measured) = 18.5 W/kg

Dipole Calibration for Head Tissue/Pin=100mW, dist=10mm, f=5300 MHz/Zoom Scan,

dist=1.4mm (8x8x7)/Cube 0: Measurement grid: dx=4mm, dy=4mm, dz=1.4mm

Reference Value = 65.90 V/m; Power Drift = 0.09 dB

Peak SAR (extrapolated) = 32.7 W/kg

SAR(1 g) = 8.64 W/kg; SAR(10 g) = 2.47 W/kg

Maximum value of SAR (measured) = 19.8 W/kg

Dipole Calibration for Head Tissue/Pin=100mW, dist=10mm, f=5500 MHz/Zoom Scan,

dist=1.4mm (8x8x7)/Cube 0: Measurement grid: dx=4mm, dy=4mm, dz=1.4mm

Reference Value = 65.91 V/m; Power Drift = 0.09 dB

Peak SAR (extrapolated) = 35.3 W/kg

SAR(1 g) = 8.93 W/kg; SAR(10 g) = 2.54 W/kg

Maximum value of SAR (measured) = 20.9 W/kg

Dipole Calibration for Head Tissue/Pin=100mW, dist=10mm, f=5600 MHz/Zoom Scan, dist=1.4mm (8x8x7)/Cube 0: Measurement grid: dx=4mm, dy=4mm, dz=1.4mm

Reference Value = 65.29 V/m; Power Drift = 0.07 dB

Peak SAR (extrapolated) = 34.8 W/kg

SAR(1 g) = 8.76 W/kg; SAR(10 g) = 2.49 W/kg

Maximum value of SAR (measured) = 20.7 W/kg

Dipole Calibration for Head Tissue/Pin=100mW, dist=10mm, f=5800 MHz/Zoom Scan, dist=1.4mm (8x8x7)/Cube 0: Measurement grid: dx=4mm, dy=4mm, dz=1.4mm

Reference Value = 62.74 V/m; Power Drift = 0.06 dB

Peak SAR (extrapolated) = 34.4 W/kg

SAR(1 g) = 8.3 W/kg; SAR(10 g) = 2.35 W/kg

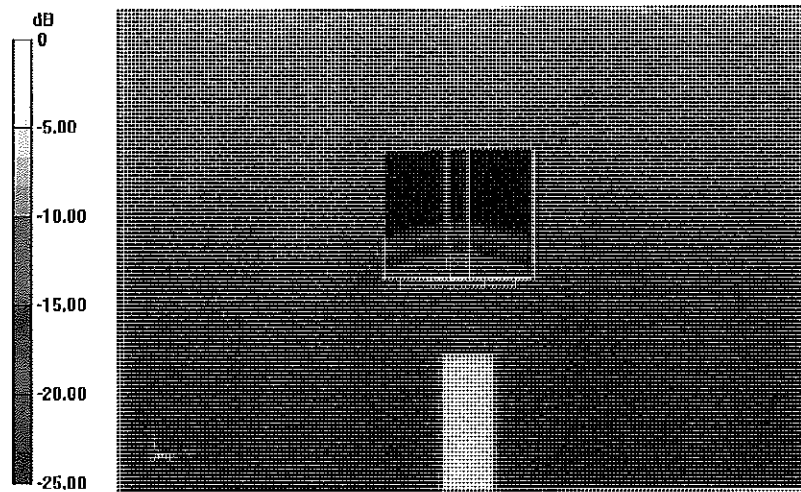

0 dB = 19.8 W/kg = 12.97 dBW/kg

Impedance Measurement Plot for Head TSL

25 Sep 2014 11:07:52

CH1 S11 1 U FS 1: 51.911 Ω -9.9180 Ω 3.0860 pF 5 200.000 000 MHz

*
Del
Cor
Avg
0
H1d

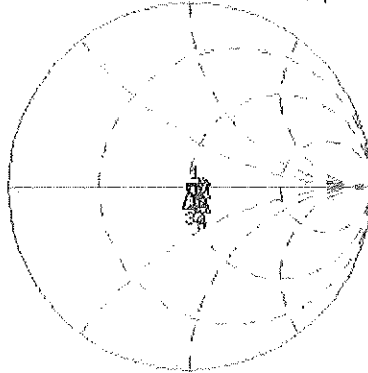

CH1 Markers

2: 54.518 Ω
-1.5078 Ω
5.30000 GHz
3: 49.566 Ω
-1.9707 Ω
5.50000 GHz
4: 56.516 Ω
-4.3633 Ω
5.60000 GHz
5: 56.555 Ω
4.3904 Ω
5.80000 GHz

CH2 S11 LOG 5 dB/REF -20 dB 1:-20.126 dB 5 200.000 000 MHz

Cor
Avg
0
H1d

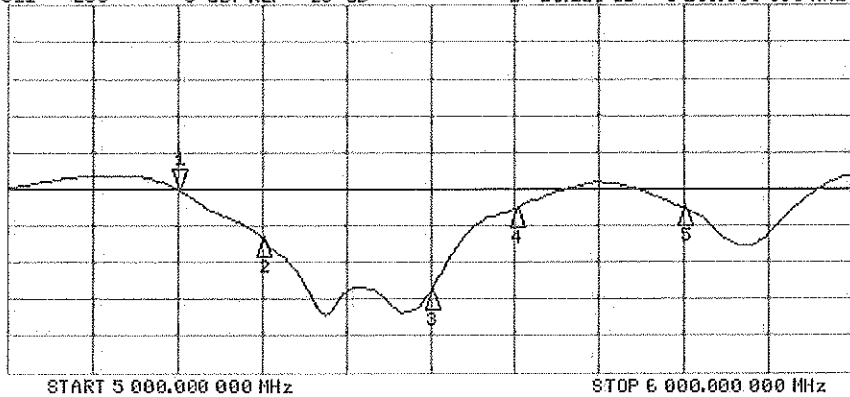

CH2 Markers

2: -26.825 dB
5.30000 GHz
3: -33.870 dB
5.50000 GHz
4: -22.660 dB
5.60000 GHz
5: -22.611 dB
5.80000 GHz

DASY5 Validation Report for Body TSL

Date: 24.09.2014

Test Laboratory: SPEAG, Zurich, Switzerland

DUT: Dipole 5GHz; Type: D5GHzV2; Serial: D5GHzV2 - SN:1191

Communication System: UID 0 - CW; Frequency: 5200 MHz, Frequency: 5300 MHz, Frequency: 5500 MHz, Frequency: 5600 MHz, Frequency: 5800 MHz

Medium parameters used: $f = 5200$ MHz; $\sigma = 5.4$ S/m; $\epsilon_r = 47.1$; $\rho = 1000$ kg/m³

Medium parameters used: $f = 5300$ MHz; $\sigma = 5.53$ S/m; $\epsilon_r = 46.9$; $\rho = 1000$ kg/m³

Medium parameters used: $f = 5500$ MHz; $\sigma = 5.79$ S/m; $\epsilon_r = 46.6$; $\rho = 1000$ kg/m³

Medium parameters used: $f = 5600$ MHz; $\sigma = 5.93$ S/m; $\epsilon_r = 46.4$; $\rho = 1000$ kg/m³

Medium parameters used: $f = 5800$ MHz; $\sigma = 6.21$ S/m; $\epsilon_r = 46.1$; $\rho = 1000$ kg/m³

Phantom section: Flat Section

Measurement Standard: DASY5 (IEBE/IEC/ANSI C63.19-2011)

DASY52 Configuration:

- Probe: EX3DV4 - SN3503; ConvF(5.01, 5.01, 5.01); Calibrated: 30.12.2013, ConvF(4.76, 4.76, 4.76); Calibrated: 30.12.2013, ConvF(4.52, 4.52, 4.52); Calibrated: 30.12.2013, ConvF(4.3, 4.3, 4.3); Calibrated: 30.12.2013, ConvF(4.47, 4.47, 4.47); Calibrated: 30.12.2013;
- Sensor-Surface: 1.4mm (Mechanical Surface Detection)
- Electronics: DAE4 Sn601; Calibrated: 18.08.2014
- Phantom: Flat Phantom 5.0 (back); Type: QD000P50AA; Serial: 1002
- DASY52 52.8.8(1222); SEMCAD X 14.6.10(7331)

Dipole Calibration for Body Tissue/Pin=100mW, dist=10mm, f=5200 MHz/Zoom Scan, dist=1.4mm (8x8x7)/Cube 0: Measurement grid: dx=4mm, dy=4mm, dz=1.4mm

Reference Value = 60.46 V/m; Power Drift = 0.02 dB

Peak SAR (extrapolated) = 30.7 W/kg

SAR(1 g) = 7.84 W/kg; SAR(10 g) = 2.18 W/kg

Maximum value of SAR (measured) = 18.5 W/kg

Dipole Calibration for Body Tissue/Pin=100mW, dist=10mm, f=5300 MHz/Zoom Scan, dist=1.4mm (8x8x7)/Cube 0: Measurement grid: dx=4mm, dy=4mm, dz=1.4mm

Reference Value = 60.42 V/m; Power Drift = 0.03 dB

Peak SAR (extrapolated) = 32.1 W/kg

SAR(1 g) = 8.05 W/kg; SAR(10 g) = 2.25 W/kg

Maximum value of SAR (measured) = 19.1 W/kg

Dipole Calibration for Body Tissue/Pin=100mW, dist=10mm, f=5500 MHz/Zoom Scan, dist=1.4mm (8x8x7)/Cube 0: Measurement grid: dx=4mm, dy=4mm, dz=1.4mm

Reference Value = 60.44 V/m; Power Drift = 0.02 dB

Peak SAR (extrapolated) = 35.8 W/kg

SAR(1 g) = 8.37 W/kg; SAR(10 g) = 2.32 W/kg

Maximum value of SAR (measured) = 20.4 W/kg

Dipole Calibration for Body Tissue/Pin=100mW, dist=10mm, f=5600 MHz/Zoom Scan, dist=1.4mm (8x8x7)/Cube 0: Measurement grid: dx=4mm, dy=4mm, dz=1.4mm
Reference Value = 60.44 V/m; Power Drift = 0.01 dB
Peak SAR (extrapolated) = 37.0 W/kg
SAR(1 g) = 8.48 W/kg; SAR(10 g) = 2.35 W/kg
Maximum value of SAR (measured) = 20.9 W/kg

Dipole Calibration for Body Tissue/Pin=100mW, dist=10mm, f=5800 MHz/Zoom Scan, dist=1.4mm (8x8x7)/Cube 0: Measurement grid: dx=4mm, dy=4mm, dz=1.4mm
Reference Value = 56.69 V/m; Power Drift = 0.01 dB
Peak SAR (extrapolated) = 36.4 W/kg
SAR(1 g) = 7.86 W/kg; SAR(10 g) = 2.17 W/kg
Maximum value of SAR (measured) = 19.7 W/kg

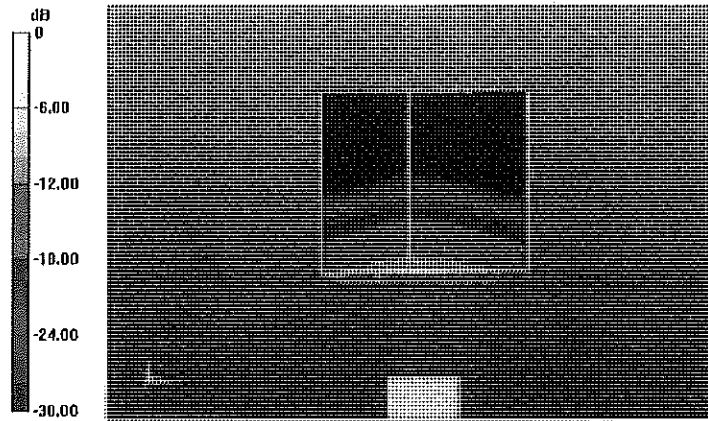

0 dB = 19.7 W/kg = 12.94 dBW/kg

Impedance Measurement Plot for Body TSL

24 Sep 2014 11:05:50

[CH1] S11 1 U FS 1: 51.867 Ω -8.0566 Ω 3.7989 pF 5 200.000 000 MHz

Del
Cor
Avg
16
H1d

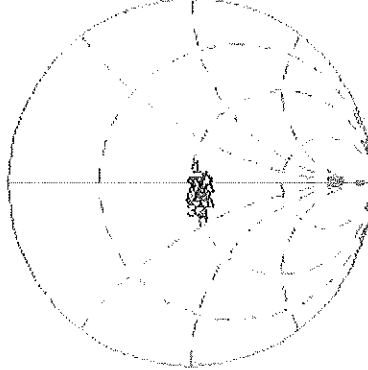

CH1 Markers

- 2: 54.531 Ω
0.1015 Ω
5.30000 GHz
- 3: 50.207 Ω
-613.28 pF
5.50000 GHz
- 4: 57.480 Ω
-3.1563 Ω
5.60000 GHz
- 5: 57.150 Ω
5.1934 Ω
5.80000 GHz

CH2 S11 LOG 5 dB/REF -20 dB 1: -21.835 dB 5 200.000 000 MHz

Cor
Avg
16
H1d

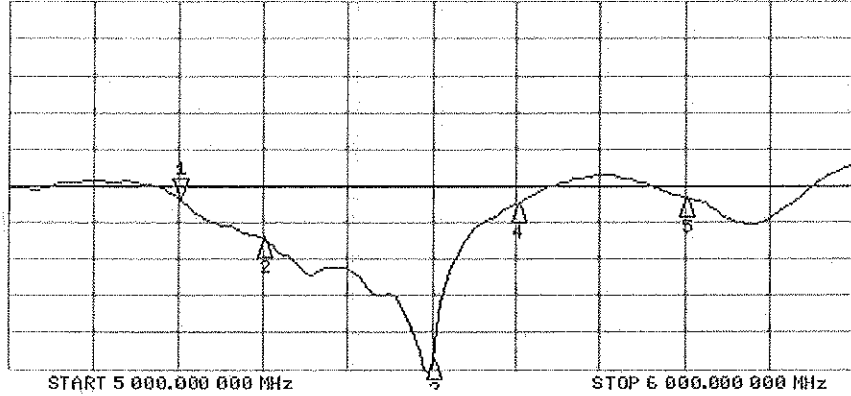

CH2 Markers

- 2: -27.251 dB
5.30000 GHz
- 3: -43.776 dB
5.50000 GHz
- 4: -22.442 dB
5.60000 GHz
- 5: -21.682 dB
5.80000 GHz