

SAR TEST REPORT

Test item : GSM/WCDMA/LTE Phone with Bluetooth, WLAN and NFC
Model No. : LG-H630, LGH630, H630, LG-H635C, LGH635C, H635C,
LG-H635c, LGH635c, H635c, LG-H635AR, LGH635AR, H635AR,
LG-H635ar, LGH635ar, H635ar
Order No. : DTNC1504-02037
Date of receipt : 2015-04-24
Test duration : 2015-05-01 ~ 2015-05-13
Date of issue : 2015-05-19
Use of report : FCC Original Grant

Applicant : LG Electronics MobileComm U.S.A., Inc.
1000 Sylvan Avenue, Englewood Cliffs NJ 07632

Test laboratory : DT&C Co., Ltd.
42, Yurim-ro, 154beon-gil, Cheoin-gu, Yongin-si, Gyeonggi-do, Korea 449-935

Test rule part : CFR §2.1093
Test environment : See appended test report
Test result : Pass Fail

The test results presented in this test report are limited only to the sample supplied by applicant and the use of this test report is inhibited other than its purpose. This test report shall not be reproduced except in full, without the written approval of DT&C Co., Ltd.

Tested by:



Engineer
ChangWon, Lee

Witnessed by:



Engineer
N/A

Reviewed by:



Technical Director
Harvey Sung

Table of Contents

1. DESCRIPTION OF DEVICE	5
1.1 Guidance Applied	6
1.2 Device Overview	6
1.3 Nominal and Maximum Output Power Specifications	7
1.4 DUT Antenna Locations	8
1.5 SAR Test Exclusions Applied	9
1.6 Power Reduction for SAR	9
1.7 Device Serial Numbers	9
1.8 LTE Information	10
2. INTROCUCTION	11
3. DESCRIPTION OF TEST EQUIPMENT	12
3.1 SAR MEASUREMENT SETUP	12
3.2 EX3DV4 / ES3DV3 Probe Specification	13
3.3 Probe Calibration Process	14
3.3.1 E-Probe Calibration	14
3.4 Data Extrapolation	15
3.5 SAM TwinPHANTOM	16
3.6 Device Holder for Transmitters	17
3.7 Brain & Muscle Simulation Mixture Characterization	17
3.8 SAR TEST EQUIPMENT	19
4. TEST SYSTEM SPECIFICATIONS	20
5. SAR MEASUREMENT PROCEDURE	21
5.1 Measurement Procedure	21
6. DEFINITION OF REFERENCE POINTS	22
6.1 Ear Reference Point	22
6.2 Handset Reference Points	22
7. TEST CONFIGURATION POSITIONS FOR HANDSETS	23
7.1 Device Holder	23
7.2 Positioning for Cheek/Touch	23
7.3 Positioning for Ear / 15 ° Tilt	23
7.4 Body-Worn Accessory Configurations	24
7.5 Extremity Exposure Configurations	24
7.6 Wireless Router Configurations	25
8. RF EXPOSURE LIMITS	26
9. FCC MEASUREMENT PROCEDURES	27
9.1 Measured and Reported SAR	27
9.2 Procedures Used to Establish RF Signal for SAR	27
9.3 SAR Measurement Conditions for WCDMA (UMTS)	27
9.3.1 Output Power Verification	27
9.3.2 Head SAR Measurements for Handsets	27
9.3.3 Body SAR Measurements	28
9.3.4 Release 5 HSDPA Data Devices	28
9.3.5 Release 6 HSUPA Data Devices	28
9.3.6 SAR Measurements Conditions for DC-HSDPA	29
9.4 SAR Measurement Conditions for LTE	29
9.4.1 Spectrum Plots for RB Configurations	29
9.4.2 MPR	29

9.4.3 A-MPR	29
9.4.4 Required RB Size and RB Offsets for SAR Testing	30
9.5 SAR Testing with 802.11 Transmitters.....	30
9.5.1 General Device Setup	30
9.5.2 Frequency Channel Configurations.....	30
10. RF CONDUCTED POWERS.....	31
10.1 GSM Conducted Powers.....	31
10.2 WCDMA Conducted Powers	32
10.3 LTE Conducted Powers	33
10.4 WLAN Conducted Powers	55
10.5 Bluetooth Conducted Powers.....	56
11. SYSTEM VERIFICATION.....	57
11.1 Tissue Verification.....	57
11.2 Test System Verification	59
12. SAR TEST RESULTS	60
12.1 Head SAR Results	60
12.2 Standalone Body-Worn SAR Worn SAR Results	64
12.3 Standalone Wireless router SAR Results	65
12.4 SAR Test Notes.....	70
13. FCC MULTI-TX AND ANTENNA SAR CONSIDERATIONS	72
13.1 Introduction.....	72
13.2 Simultaneous Transmission Procedures.....	72
13.3 Simultaneous Transmission Capabilities	72
13.4 Head SAR Simultaneous Transmission Analysis.....	74
13.5 Body-Worn Simultaneous Transmission Analysis.....	76
13.6 Hotspot SAR Simultaneous Transmission Analysis.....	77
13.7 Simultaneous Transmission Conclusion	78
14. SAR MEASUREMENT VARIABILITY	79
14.1 Measurement Variability	79
14.2 Measurement Uncertainty.....	79
15. IEEE P1528 –MEASUREMENT UNCERTAINTIES.....	80
16. CONCLUSION.....	92
17. REFERENCES	93
Attachment 1. – Probe Calibration Data	95
Attachment 2. – Dipole Calibration Data	118
Attachment 3. – SAR SYSTEM VALIDATION	167

Test Report Version

Test Report No.	Date	Description
DRRFCC1505-0046	May. 19, 2015	Final version for approval

1. DESCRIPTION OF DEVICE

Environmental evaluation measurements of specific absorption rate (SAR) distributions in emulated human head and body tissues exposed to radio frequency (RF) radiation from wireless portable devices for compliance with the rules and regulations of the U.S. Federal Communications Commission (FCC).

General Information:

EUT type	GSM/WCDMA/LTE Phone with Bluetooth, WLAN and NFC				
FCC ID	ZNFH630				
Equipment model name	LG-H630				
Equipment add model name	LGH630 H630, LG-H635C, LGH634C, H635C, LG-H635c, LGH635c, H635c, LG-H635AR, LGH635AR, H635AR, LG-H635ar, LGH635ar, H635ar 15 models are same mechanical, electrical and functional. The only difference is the model name, which are changed for marketing purpose.				
Equipment serial no.	Identical prototype				
Mode(s) of Operation	GSM 850, PCS 1900, WCDMA 850, WCDMA 1900, LTE Band 2, 4,5, 7,17, 2.4 G W-LAN (802.11b/g/n HT20),				
TX Frequency Range	824.2 ~ 848.8 MHz (Cellular Band) / 1850.2 ~ 1909.8 MHz (PCS Band) 826.4 ~ 846.6 MHz (WCDMA FDD V) / 1852.4 ~ 1907.6 MHz (WCDMA FDD II) 1710.7 ~ 1754.3 MHz (LTE Band 4) / 1850.7 ~ 1909.3 MHz (LTE Band 2) 824.7 ~ 848.3 MHz (LTE Band 5) / 2502.5 ~ 2567.5 MHz (LTE Band 7) 706.5 ~ 713.5 MHz (LTE Band 17) / 2412 ~ 2462 MHz (802.11b/g/n HT20)				
RX Frequency Range	869.2 ~ 893.8 MHz (Cellular Band) / 1930.2 ~ 1989.8 MHz (PCS Band) 871.4 ~ 891.6 MHz (WCDMA FDD V) / 1932.4 ~ 1987.6 MHz (WCDMA FDD II) 2110.7 ~ 2154.3 MHz (LTE Band 4) / 1930.7 ~ 1989.3 MHz (LTE Band 2) 869.7 ~ 893.3 MHz (LTE Band 5) / 2622.5 ~ 2687.5 MHz (LTE Band 7) 736.5 ~ 743.5 MHz (LTE Band 17) / 2412 ~ 2462 MHz (802.11b/g/n HT20)				
Equipment Class	Band	Measured Conducted Power [dBm]	Reported SAR		
			1g SAR (W/kg)		
			Head	Body-worn	Hotspot
PCE	GSM850	33.60	0.35	0.46	N/A
PCE	GPRS 850	27.60	0.43	0.51	0.51
PCE	PCS 1900	30.60	0.46	0.34	N/A
PCE	GPRS 1900	26.00	0.51	0.48	0.48
PCE	WCDMA 850	24.10	0.34	0.62	0.62
PCE	WCDMA 1900	23.70	0.53	0.64	0.64
PCE	LTE Band 17	23.60	0.27	0.52	0.52
PCE	LTE Band 5 (Cell)	23.10	0.39	0.56	0.56
PCE	LTE Band 4 (AWS)	23.00	0.74	0.74	0.74
PCE	LTE Band 2 (PCS)	23.10	0.51	0.62	0.62
PCE	LTE Band 7	23.05	0.16	1.09	1.09
DTS	2.4 GHz W-LAN	14.46	0.33	0.14	0.14
DSS/DTS	Bluetooth	7.59	N/A	0.12 ^{Note}	N/A
Simultaneous SAR per KDB 690783 D01v01r03			1.06	1.22	1.22
FCC Equipment Class	Licensed Portable Transmitter Held to Ear (PCE)				
Date(s) of Tests	2015-05-01 ~ 2015-05-13				
Antenna Type	Internal Type Antenna				
Note	Bluetooth SAR was estimated.				
Functions	<ul style="list-style-type: none"> ● GSM/GPRS(GPRS Class: 33) / EDGE (EDGE Class: 33) supported. * DTM is not supported. ● BT(2.4GHz) / W-LAN(2.4GHz 802.11b/g/n(HT20)) supported. * No simultaneous transmission between BT & WLAN. ● Simultaneous transmission between GSM, WCDMA voice & WLAN / GPRS, WCDMA & WLAN / LTE & WLAN. ● VoIP supported. ● W-LAN 2.4GHz Mobile Hotspot supported. 				

1.1 Guidance Applied

- IEEE 1528-2003
- FCC KDB Publication 941225 D01 3G SAR Measurement Procedures v03
- FCC KDB Publication 941225 D05 SAR for LTE Devices v02r03
- FCC KDB Publication 941225 D06 Hot Spot SAR v02
- FCC KDB Publication 248227 D01v02 (802.11 Wi-Fi SAR)
- FCC KDB Publication 447498 D01v05r02 (General SAR Guidance)
- FCC KDB Publication 648474 D04 Handset SAR v01r02
- FCC KDB Publication 865664 D01 SAR Measurement 100 MHz to 6 GHz v01r03
- FCC KDB Publication 865664 D02 RF Exposure Reporting v01r01
- October 2013 TCB Workshop Notes (GPRS testing criteria)

1.2 Device Overview

Band & Mode	Operating Modes	Tx Frequency
GSM/GPRS/EDGE 850	Voice/Data	824.2 ~ 848.8 MHz
GSM/GPRS/EDGE 1900	Voice/Data	1850.2 ~ 1909.8 MHz
WCDMA 850	Voice/Data	826.4 ~ 846.6 MHz
WCDMA 1900	Voice/Data	1852.4 ~ 1907.6 MHz
LTE Band 17	Data	706.5 ~ 713.5 MHz
LTE Band 5 (Cell)	Data	824.7 ~ 848.3 MHz
LTE Band 4 (AWS)	Data	1710.7 ~ 1754.3 MHz
LTE Band 2 (PCS)	Data	1850.7 ~ 1909.3 MHz
LTE Band 7	Data	2502.5 ~ 2567.5 MHz
2.4 GHz WLAN	Data	2412 ~ 2462 MHz
Bluetooth	Data	2402 ~ 2480 MHz
NFC	Data	13.56 MHz

1.3 Nominal and Maximum Output Power Specifications

This device operates using the following maximum and nominal output power specifications. SAR values were scaled to the maximum allowed power to determine compliance per KDB Publication 447498 D01v05r02.

Band & Mode		Voice [dBm]	Burst Average GMSK [dBm]				Burst Average 8-PSK [dBm]			
			1 TX Slot	1 TX Slot	2 TX Slot	3 TX Slot	4 TX Slot	1 TX Slot	2 TX Slot	3 TX Slot
GSM/GPRS/EDGE 850	Maximum	33.7	33.7	30.7	29.2	27.7	27.2	24.7	23.2	21.7
	Nominal	33.2	33.2	30.2	28.7	27.2	26.7	24.2	22.7	21.2
GSM/GPRS/EDGE 1900	Maximum	31.2	31.2	27.7	26.2	24.7	26.2	23.7	22.2	20.7
	Nominal	30.7	30.7	27.2	25.7	24.2	25.7	23.2	21.7	20.2

Band & Mode		3GPP WCDMA	Modulated Average [dBm]			
			3GPP HSDPA			
			Rel. 5			
		Rel. 99	Subtest 1	Subtest 2	Subtest 3	Subtest 4
WCDMA 850	Maximum	24.2	24.2	24.2	23.7	23.7
	Nominal	23.7	23.7	23.7	23.2	23.2
WCDMA 1900	Maximum	23.7	23.7	23.7	23.2	23.2
	Nominal	23.2	23.2	23.2	22.7	22.7

Note : This device supports HSUPA, DC-HSDPA but the manufacturer only declares on the tune-up procedure that the HSUPA, DC-HSDPA transmitter's power will not exceed the R99 maximum transmit power in devices based on Qualcomm's HSPA chipset solution.

Band & Mode	Modulated Average[dBm]	
LTE Band 17	Maximum	23.7
	Nominal	23.2
LTE Band 5 (Cell)	Maximum	23.2
	Nominal	22.7
LTE Band 4 (AWS)	Maximum	23.2
	Nominal	22.7
LTE Band 2 (PCS)	Maximum	23.2
	Nominal	22.7
LTE Band 7	Maximum	23.2
	Nominal	22.7

Band & Mode	Modulated Average[dBm]	
IEEE 802.11b (2.4 GHz)	Maximum	15.0
	Nominal	14.0
IEEE 802.11g (2.4 GHz)	Maximum	12.0
	Nominal	11.0
IEEE 802.11n HT20(2.4 GHz)	Maximum	11.0
	Nominal	10.0
Bluetooth 1 Mbps	Maximum	8.0
	Nominal	7.0
Bluetooth 2 Mbps	Maximum	6.0
	Nominal	5.0
Bluetooth 3 Mbps	Maximum	6.0
	Nominal	5.0
Bluetooth LE	Maximum	-1.0
	Nominal	-2.0

1.4 DUT Antenna Locations

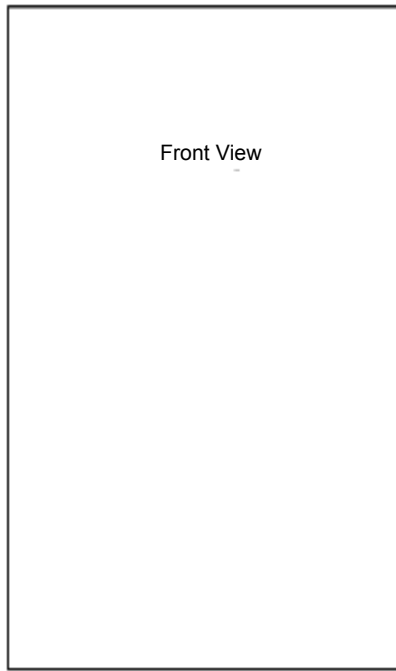

Note 1: Exact antenna dimensions and separation distances are shown in the “Antenna Distance_ZNFH630” in the FCC Filing.
 Note 2: Since the diagonal dimension of this device is > 160 mm, it is considered a “phablet”.

Mode	Mobile Hotspot Sides for SAR Testing					
	Top	Bottom	Front	Rear	Right	Left
GPRS 850	X	O	O	O	O	O
GPRS 1900	X	O	O	O	O	O
WCDMA 850	X	O	O	O	O	O
WCDMA 1900	X	O	O	O	O	O
LTE Band 17	X	O	O	O	O	O
LTE Band 5 (Cell)	X	O	O	O	O	O
LTE Band 4 (AWS)	X	O	O	O	O	O
LTE Band 2 (PCS)	X	O	O	O	O	O
LTE Band 7	X	O	O	O	O	O
2.4G W-LAN(802.11b/g/n)	O	X	O	O	O	X

Table 1.1 Mobile Hotspot Sides for SAR Testing

Note:

- Particular DUT edges were not required to be evaluated for Wireless Router SAR if the edges were greater than 2.5 cm from the transmitting antenna according to FCC KDB Publication 941225 D06v02 guidance, page 2. The antenna document shows the distances between the transmit antennas and the edges of the device.

1.5 SAR Test Exclusions Applied

(A) WIFI & BT

Since Wireless Router operations of this device are only allowed using 2.4 GHzWIFI,only 2.4 GHz WIFI Hotspot SAR tests and combinations are considered for SAR with respect to Wireless Router configurations according to FCC KDB 941225 D06v02.

Per FCC KDB 447498 D01v05r02, the SAR exclusion threshold for distances < 50 mm is defined by the following equation:

$$\frac{\text{Max Power of Channel (mW)}}{\text{Test Separation Dist (mm)}} * \sqrt{\text{Frequency(GHz)}} \leq 3.0$$

Based on the maximum conducted power of **Bluetooth** (rounded to the nearest mW) and the antenna to user separation distance, **Bluetooth SAR was not required**; $[(6/10)^* \sqrt{2.480}] = \underline{0.9} < 3.0$.

Based on the maximum conducted power of **Bluetooth LE** (rounded to the nearest mW) and the antenna to user separation distance, **Bluetooth LE SAR was not required**; $[(1/10)^* \sqrt{2.480}] = \underline{0.1} < 3.0$.

Based on the maximum conducted power of **2.4 GHz WIFI** (rounded to the nearest mW) and the antenna to user separation distance, **2.4 GHz WIFI SAR was required**; $[(28/10)^* \sqrt{2.462}] = \underline{4.4} > 3.0$.

Per KDBPublication 447498 D01v05r02, the maximum power of the channel was rounded to the nearest mWbefore calculation.

(B) Licensed Transmitter(s)

GSM/GPRS DTM is not supported for US bands. Therefore, the GSM Voice modes in this report donot transmit simultaneously with GPRS/EDGE Data.

1.6 Power Reduction for SAR

There is no power reduction used for any band/mode implemented in this device for SAR purposes.

1.7 Device Serial Numbers

Band & Mode	Head Serial Number	Body-Worn Serial Number	Hotspot Serial Number
GSM/GPRS 850	FCC #1	FCC #1	FCC #1
GSM/GPRS 1900	FCC #1	FCC #1	FCC #1
WCDMA 850	FCC #1	FCC #1	FCC #1
WCDMA 1900	FCC #1	FCC #1	FCC #1
LTE Band 17	FCC #1	FCC #1	FCC #1
LTE Band 5 (Cell)	FCC #1	FCC #1	FCC #1
LTE Band 4 (AWS)	FCC #1	FCC #1	FCC #1
LTE Band 2 (PCS)	FCC #1	FCC #1	FCC #1
LTE Band 7	FCC #1	FCC #1	FCC #1
2.4 GHz WLAN	FCC #1	FCC #1	FCC #1

1.8 LTE Information

LTE Information			
FCC ID	ZNFH630		
Form Factor	Portable Handset		
Frequency Range of each LTE transmission Band	LTE Band 17 (706.5 ~ 713.5 MHz)		
	LTE Band 5 (Cell) (824.7 ~ 848.3 MHz)		
	LTE Band 4 (AWS) (1710.7 ~ 1754.3 MHz)		
	LTE Band 2 (PCS) (1850.7 ~ 1909.3 MHz)		
	LTE Band 7 (2502.5 ~ 2567.5 MHz)		
Channel Bandwidths	LTE Band 17: 10 MHz, 5 MHz		
	LTE Band 5 (Cell): 10 MHz, 5 MHz, 3 MHz, 1.4 MHz		
	LTE Band 4 (AWS): 20 MHz, 15 MHz, 10 MHz, 5 MHz, 3 MHz, 1.4 MHz		
	LTE Band 2 (PCS): 20 MHz, 15 MHz, 10 MHz, 5 MHz, 3 MHz, 1.4 MHz		
	LTE Band 7: 20 MHz, 15 MHz, 10 MHz, 5 MHz		
Channel Number and Frequencies (MHz)	Low	Mid	High
LTE Band 17: 10 MHz	709(23780) ^{Note1}	-	711(23800) ^{Note1}
LTE Band 17: 5 MHz	706.5(23755) ^{Note1}	-	713.5(23825) ^{Note1}
LTE Band 5 (Cell): 10 MHz	829(20450) ^{Note1}	-	844(20600) ^{Note1}
LTE Band 5 (Cell): 5 MHz	826.5(20425)	836.5(20525)	846.5(20625)
LTE Band 5 (Cell): 3 MHz	825.5(20415)	836.5(20525)	847.5(20635)
LTE Band 5 (Cell): 1.4 MHz	824.7(20407)	836.5(20525)	848.3(20643)
LTE Band 4 (AWS): 20 MHz	1720(20050) ^{Note1}	-	1745(20300) ^{Note1}
LTE Band 4 (AWS): 15 MHz	1717.5(20025)	1732.5(20175)	1747.5(20325)
LTE Band 4 (AWS): 10 MHz	1715(20000)	1732.5(20175)	1750(20350)
LTE Band 4 (AWS): 5 MHz	1712.5(19975)	1732.5(20175)	1752.5(20375)
LTE Band 4 (AWS): 3 MHz	1711.5(19965)	1732.5(20175)	1753.5(20385)
LTE Band 4 (AWS): 1.4 MHz	1710.7(19957)	1732.5(20175)	1754.3(20393)
LTE Band 2 (PCS): 20 MHz	1860(18700)	1880(18900)	1900(19100)
LTE Band 2 (PCS): 15 MHz	1857.5(18675)	1880(18900)	1902.5(19125)
LTE Band 2 (PCS): 10 MHz	1855(18650)	1880(18900)	1905(19150)
LTE Band 2 (PCS): 5 MHz	1852.5(18625)	1880(18900)	1907.5(19175)
LTE Band 2 (PCS): 3 MHz	1851.5(18615)	1880(18900)	1908.5(19185)
LTE Band 2 (PCS): 1.4 MHz	1850.7(18607)	1880(18900)	1909.3(19193)
LTE Band 7: 20 MHz	2510(20850)	2535(21100)	2560(21350)
LTE Band 7: 15 MHz	2507.5(20825)	2535(21100)	2562.5(21375)
LTE Band 7: 10 MHz	2505(20800)	2535(21100)	2565(21400)
LTE Band 7: 5 MHz	2502.5(20775)	2535(21100)	2567.5(21425)
UE Category / Modulations Supported	UE Category 4 / QPSK, 16QAM		
LTE MPR Permanently implemented per 3GPP TS 36.101 section 6.2.3~6.2.5? (manufacturer attestation to be provided)	Yes		
A-MPR (Additional MPR) disabled for SAR Testing?	Yes		
LTE Carrier Aggregation	This device does not support both UL and DL carrier aggregation.		

Note 1: LTE Band 4 (AWS) at 20 MHz bandwidth does not support 3 non-overlapping channels. Per KDB 941225D05v02r03, when a device does not support at least 3 non-overlapping channels in certain channel bandwidths, test the available non-overlapping channels.

2. INTROCUCTION

The FCC and Industry Canada have adopted the guidelines for evaluating the environmental effects of radio frequency (RF) radiation in ET Docket 93-62 on Aug. 6, 1996 and Health Canada Safety Code 6 to protect the public and workers from the potential hazards of RF emissions due to FCC-regulated portable devices.

The FCC has adopted the guidelines for evaluating the environmental effects of radio frequency radiation in ET Docket 93-62 on Aug. 6, 1996 to protect the public and workers from the potential hazards of RF emissions due to FCC-regulated portable devices. The safety limits used for the environmental evaluation measurements are based on the criteria published by the American National Standards Institute (ANSI) for localized specific absorption rate (SAR) in IEEE/ANSI C95.1-2005 Standard for Safety Levels with Respect to Human Exposure to Radio Frequency Electromagnetic Fields, 3 kHz to 300 GHz. 1992 by the Institute of Electrical and Electronics Engineers, Inc., New York, New York 10017. The measurement procedure described in IEEE/ANSI C95.3-1992 Recommended Practice for the Measurement of Potentially Hazardous Electromagnetic Fields - RF and Microwave is used for guidance in measuring SAR due to the RF radiation exposure from the Equipment Under Test (EUT). These criteria for SAR evaluation are similar to those recommended by the National Council on Radiation Protection and Measurements (NCRP) in Biological Effects and Exposure Criteria for Radio frequency Electromagnetic Fields," NCRP Report No. 86 NCRP, 1986, Bethesda, MD 20814. SAR is a measure of the rate of energy absorption due to exposure to an RF transmitting source. SAR values have been related to threshold levels for potential biological hazards.

SAR Definition

Specific Absorption Rate (SAR) is defined as the time derivative (rate) of the incremental energy (dU) absorbed by (dissipated in) an incremental mass (dm) contained in a volume element (dV) of a given density (ρ) It is also defined as the rate of RF energy absorption per unit mass at a point in an absorbing body (see Fig. 2.1)

$$SAR = \frac{d}{dt} \left(\frac{dU}{dm} \right) = \frac{d}{dt} \left(\frac{dU}{\rho dv} \right)$$

Fig. 2.1 SAR Mathematical Equation

SAR is expressed in units of Watts per Kilogram (W/kg).

$$SAR = \frac{\sigma \cdot E^2}{\rho}$$

where:

- σ = conductivity of the tissue-simulating material (S/m)
- ρ = mass density of the tissue-simulating material (kg/m^3)
- E = Total RMS electric field strength (V/m)

NOTE: The primary factors that control rate of energy absorption were found to be the wavelength of the incident field in relations to the dimensions and geometry of the irradiated organism, the orientation of the organism in relation to the polarity of field vectors, the presence of reflecting surfaces, and whether conductive contact is made by the organism with a ground plane.

3. DESCRIPTION OF TEST EQUIPMENT

3.1 SAR MEASUREMENT SETUP

Measurements are performed using the DASY5 automated dosimetric assessment system. The DASY5 is made by Schmid & Partner Engineering AG (SPEAG) in Zurich, Switzerland and consists of high precision robotics system (Staubli), robot controller, desktop computer, near-field probe, probe alignment sensor, and the generic twin phantom containing the brain equivalent material. The robot is a six-axis industrial robot performing precise movements to position the probe to the location (points) of maximum electromagnetic field (EMF) (see Fig. 3.1).

A cell controller system contains the power supply, robot controller teach pendant (Joystick), and a remote control used to drive the robot motors. The PC consists of the Intel Core i7-3770 3.40 GHz desktop computer with Windows NT system and SAR Measurement Software DASY5, A/D interface card, monitor, mouse, and keyboard. The Staubli Robot is connected to the cell controller to allow software manipulation of the robot. A data acquisition electronic (DAE) circuit that performs the signal amplification, signal multiplexing, AD-conversion, offset measurements, mechanical surface detection, collision detection, etc. is connected to the Electro-optical coupler (EOC). The EOC performs the conversion from the optical to digital electric signal of the DAE and transfers data to the PC plug-in card.

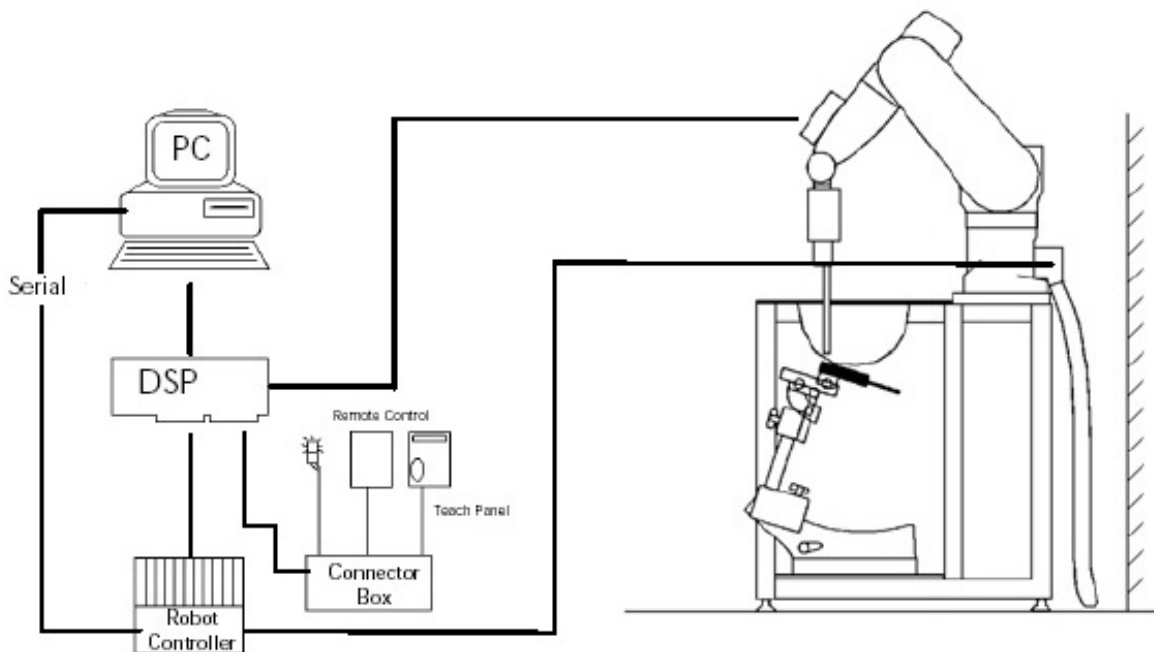

Figure 3.1 SAR Measurement System Setup

The DAE4 consists of a highly sensitive electrometer-grade preamplifier with auto-zeroing, a channel and gain-switching multiplexer, a fast 16 bit AD-converter and a command decoder and control logic unit. Transmission to the PC-card is accomplished through an optical downlink for data and status information and an optical uplink for commands and clock lines. The mechanical probe mounting device includes two different sensor systems for frontal and sidewise probe contacts. They are also used for mechanical surface detection and probe collision detection. The robot uses its on-controller with a built in VME-bus computer. The system is described in detail.

3.2 EX3DV4 / ES3DV3 Probe Specification

Calibration	In air from 10 MHz to 6 GHz / In air from 10 MHz to 3 GHz In brain and muscle simulating tissue at Frequencies of 450 MHz, 600 MHz, 750 MHz, 835 MHz, 900 MHz, 1750 MHz, 1900 MHz, 2300 MHz, 2450 MHz, 2600 MHz, 3500 MHz, 5200 MHz, 5300 MHz, 5500 MHz, 5600 MHz, 5800 MHz 450 MHz, 600 MHz, 750 MHz, 835 MHz, 900 MHz, 1750 MHz, 1900 MHz, 2300 MHz, 2450 MHz
Frequency	10 MHz to 6 GHz / 10 MHz to 3 GHz
Linearity	± 0.2 dB(30 MHz to 6 GHz) / ± 0.2 dB (30 MHz to 3 GHz)
Dynamic	10 μ W/g to > 100 mW/g
Range	Linearity : ± 0.2 dB
Dimensions	Overall length : 337 mm
Tip length	20 mm
Body diameter	12 mm
Tip diameter	2.5 mm
Distance from probe tip to sensor center	1.0 mm
Application	SAR Dosimetry Testing Compliance tests of mobile phones

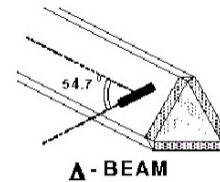
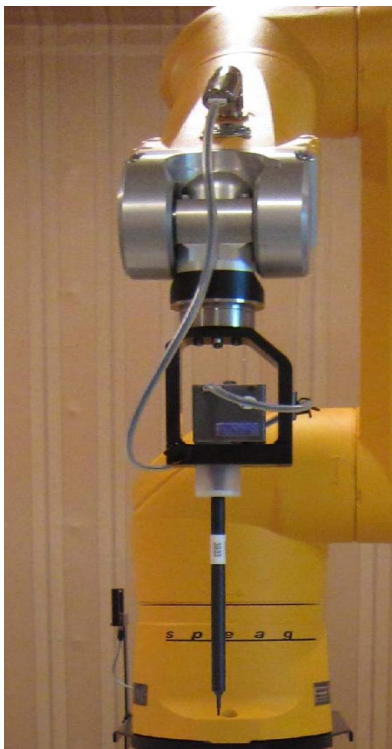

Figure 3.2 Triangular Probe Configurations



Figure 3.3 Probe Thick-Film Technique



DAE System

The SAR measurements were conducted with the dosimetric probe EX3DV4, designed in the classical triangular configuration (see Fig. 3.2) and optimized for dosimetric evaluation. The probe is constructed using the thick film technique; with printed resistive lines on ceramic substrates. The probe is equipped with an optical multi-tier line ending at the front of the probe tip. It is connected to the EOC box on the robot arm and provides an automatic detection of the phantom surface. Half of the fibers are connected to a pulsed infrared transmitter, the other half to a synchronized receiver. As the probe approaches the surface, the reflection from the surface produces a coupling from the transmitting to the receiving fibers. This reflection increases first during the approach, reaches maximum and then decreases. If the probe is flatly touching the surface, the coupling is zero. The distance of the coupling maximum to the surface is independent of the surface reflectivity and largely independent of the surface to probe angle. The DASY5 software reads the reflection during a software approach and looks for the maximum using a 2nd order fitting. The approach is stopped at reaching the maximum.

3.3 Probe Calibration Process

3.3.1E-Probe Calibration

Dosimetric Assessment Procedure

Each probe is calibrated according to a dosimetric assessment procedure with accuracy better than +/- 10%. The spherical isotropy was evaluated with the procedure and found to be better than +/-0.25dB. The sensitivity parameters (NormX, NormY, NormZ), the diode compression parameter (DCP) and the conversion factor (ConvF) of the probe is tested.

Free Space Assessment

The free space E-field from amplified probe outputs is determined in a test chamber. This is performed in a TEM cell for frequencies below 1 GHz, and in a waveguide above 1GHz for free space. For the free space calibration, the probe is placed in the volumetric center of the cavity at the proper orientation with the field. The probe is then rotated 360 degrees.

Temperature Assessment *

E-field temperature correlation calibration is performed in a flat phantom filled with the appropriate simulated brain tissue. The measured free space E-field in the medium, correlates to temperature rise in a dielectric medium. For temperature correlation calibration a RF transparent thermistor based temperature probe is used in conjunction with the E-field probe.

$$SAR = C \frac{\Delta T}{\Delta t}$$

where:

Δt = exposure time (30 seconds),

C = heat capacity of tissue (brain or muscle),

ΔT = temperature increase due to RF exposure.

$$SAR = \frac{|E|^2 \cdot \sigma}{\rho}$$

where:

σ = simulated tissue conductivity,

ρ = Tissue density (1.25 g/cm³ for brain tissue)

SAR is proportional to $\Delta T / \Delta t$, the initial rate of tissue heating, before thermal diffusion takes place. Now it's possible to quantify the electric field in the simulated tissue by equating the thermally derived SAR to the E- field;

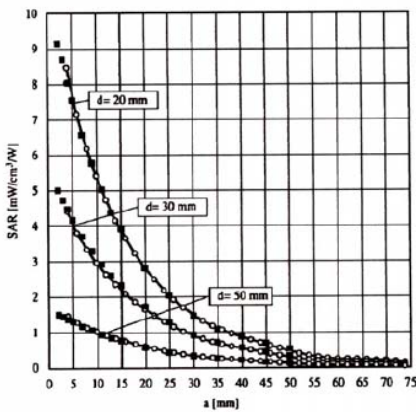

Figure 3.4 E-Field and Temperature Measurements at 900MHz

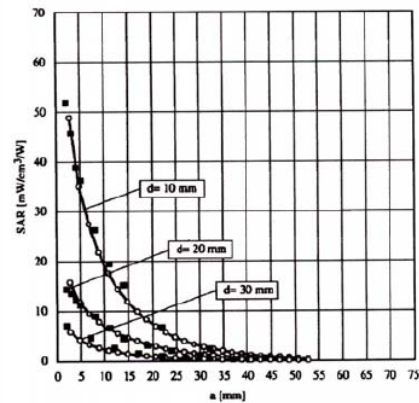

Figure 3.5 E-Field and Temperature Measurements at 1800MHz

3.4 Data Extrapolation

The DASYS5 software automatically executes the following procedures to calculate the field units from the microvolt readings at the probe connector. The first step of the evaluation is a linearization of the filtered input signal to account for the compression characteristics of the detector diode. The compensation depends on the input signal, the diode type and the DC-transmission factor from the diode to the evaluation electronics. If the exciting field is pulsed, the crest factor of the signal must be known to correctly compensate for peak power. The formula for each channel can be given like below;

$$V_i = U_i + U_i^2 \cdot \frac{cf}{dcp_i}$$

with V_i = compensated signal of channel i (i=x,y,z)
 U_i = input signal of channel i (i=x,y,z)
 cf = crest factor of exciting field (DASY parameter)
 dcp_i = diode compression point (DASY parameter)

From the compensated input signals the primary field data for each channel can be evaluated:

E-field probes:

$$E_i = \sqrt{\frac{V_i}{Norm_i \cdot ConvF}}$$

with V_i = compensated signal of channel i (i = x,y,z)
 $Norm_i$ = sensor sensitivity of channel i (i = x,y,z)
 $\mu V/(V/m)^2$ for E-field probes
 $ConvF$ = sensitivity of enhancement in solution
 E_i = electric field strength of channel i in V/m

The RSS value of the field components gives the total field strength (Hermetian magnitude):

$$E_{tot} = \sqrt{E_x^2 + E_y^2 + E_z^2}$$

The primary field data are used to calculate the derived field units.

$$SAR = E_{tot}^2 \cdot \frac{\sigma}{\rho \cdot 1000}$$

with SAR = local specific absorption rate in W/g
 E_{tot} = total field strength in V/m
 σ = conductivity in [mho/m] or [Siemens/m]
 ρ = equivalent tissue density in g/cm³

The power flow density is calculated assuming the excitation field to be a free space field.

$$P_{free} = \frac{E_{tot}^2}{3770}$$

with P_{free} = equivalent power density of a plane wave in W/cm²
 E_{tot} = total electric field strength in V/m

3.5 SAM TwinPHANTOM

The SAM Twin Phantom V5.0 is constructed of a fiberglass shell integrated in a woodentable. The shape of the shell is based on data from an anatomical study designed todetermine the maximum exposure in at least 90% of all users. Iteablesthedosimetric evaluation of left and right hand phone usage as well as body mounted usage at the flat phantom region. A cover preventsstheevaporation of the liquid.

Referencemarkings on thePhantom allow thecomplete setup of all predefined phantom positionsand measurement grids by manually teaching three points in the robot. (see Fig. 3.6)

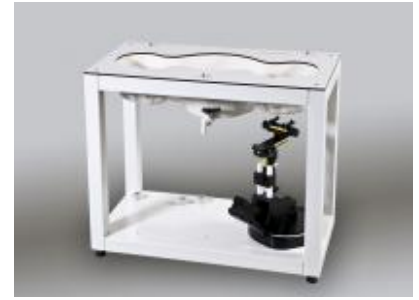

Figure 3.6 SAM Twin Phantom

SAM Twin Phantom Specification:

Construction	The shell corresponds to the specifications of the Specific Anthropomorphic Mannequin (SAM) phantom defined in IEEE 1528 and IEC 62209-1. It enables the dosimetric evaluation of left and right hand phone usage as well as body mounted usage at the flat phantom region. A cover prevents evaporation of the liquid. Reference markings on the phantom allow the complete setup of all predefined phantom positions and measurement grids by teaching three points with the robot. Twin SAM V5.0 has the same shell geometry and is manufactured from the same material as Twin SAM V4.0, but has reinforced top structure.
Shell Thickness	2 ± 0.2 mm
Filling Volume	Approx. 25 liters
Dimensions	Length: 1000 mm Width: 500 mm Height: adjustable feet

Specific Anthropomorphic Mannequin (SAM) Specifications:

The phantom for handset SAR assessment testing is a low-loss dielectric shell, with shapeand dimensions derived from theanthropometric data of the 90th percentile adult male head dimensions as tabulated by the US Army. The SAM Twin Phantom shell is bisected alongthemid-sagittal plane into right and left halves (see Fig. 3.7). The perimeter sidewalls of each phantom halves are extended to allow filling withliquidto a depth thatissufficienttominimized reflections from the upper surface. The liquiddepthismaintained at a minimum depth of 15cm to minimize reflections from the upper surface.



Figure 3.7 Sam Twin Phantom shell

3.6 Device Holder for Transmitters

In combination with the Twin SAM Phantom V4.0/V4.0c, V5.0 or ELI4, the Mounting Device enables the rotation of the mounted transmitter device in spherical coordinates. Rotation point is the ear opening point. Transmitter devices can be easily and accurately positioned according to IEC, IEEE, FCC or other specifications. The device holder can be locked for positioning at different phantom sections (left head, right head, flat).

Note: A simulating human hand is not used due to the complex anatomical and geometrical structure of the hand that may produce infinite number of configurations. To produce the worst-case condition (the hand absorbs antenna output power), the hand is omitted during the tests.



Figure 3.8 Mounting Device

3.7 Brain & Muscle Simulation Mixture Characterization

The brain and muscle mixtures consist of a viscous gel using hydrox-ethylcellulose (HEC) gelling agent and saline solution (see Table 3.1). Preservation with a bactericide is added and visual inspection is made to make sure air bubbles are not trapped during the mixing process. The mixture is calibrated to obtain proper dielectric constant (permittivity) and conductivity of the desired tissue. The mixture characterizations used for the brain and muscle tissue simulating liquids are according to the data by C. Gabriel and G. Hartsgrrove.



Figure 3.9 Simulated Tissue

Table 3.1 Composition of the Tissue Equivalent Matter

Ingredients (% by weight)	Frequency (MHz)							
	835		1900		2450		5200 ~ 5800	
Tissue Type	Head	Body	Head	Body	Head	Body	Head	Body
Water	40.19	50.75	55.24	70.23	71.88	73.40	65.52	80.00
Salt (NaCl)	1.480	0.940	0.310	0.290	0.160	0.060	-	-
Sugar	57.90	48.21	-	-	-	-	-	-
HEC	0.250	-	-	-	-	-	-	-
Bactericide	0.180	0.100	-	-	-	-	-	-
Triton X-100	-	-	-	-	19.97	-	17.24	-
DGBE	-	-	44.45	29.48	7.990	26.54	-	-
Diethylene glycol hexyl ether	-	-	-	-	-	-	17.24	-
Polysorbate (Tween) 80	-	-	-	-	-	-	-	20.00
Target for Dielectric Constant	41.5	55.2	40.0	53.3	39.2	52.7	-	-
Target for Conductivity (S/m)	0.90	0.97	1.40	1.52	1.80	1.95	-	-

Salt: 99 % Pure Sodium Chloride Sugar: 98 % Pure Sucrose
 Water: De-ionized, 16M resistivity HEC: Hydroxyethyl Cellulose
 DGBE: 99 % Di(ethylene glycol) butyl ether,[2-(2-butoxyethoxy) ethanol]
 Triton X-100(ultra pure): Polyethylene glycol mono[4-(1,1,3,3-tetramethylbutyl)phenyl] ether

3.8 SAR TEST EQUIPMENT

Table 3.2 Test Equipment Calibration

	Type	Manufacturer	Model	Cal.Date	Next.Cal.Date	S/N
<input checked="" type="checkbox"/>	SEMITEC Engineering	SEMITEC	N/A	N/A	N/A	Shield Room
<input checked="" type="checkbox"/>	Robot	SCHMID	TX60L	N/A	N/A	F12/5LP5A1/A/01
<input checked="" type="checkbox"/>	Robot Controller	SCHMID	C58C	N/A	N/A	F12/5LP5A1/C/01
<input checked="" type="checkbox"/>	Joystick	SCHMID	N/A	N/A	N/A	S-12030401
<input checked="" type="checkbox"/>	Intel Core i7-2600 3.40 GHz Windows 7 Professional	N/A	N/A	N/A	N/A	N/A
<input checked="" type="checkbox"/>	Probe Alignment Unit LB	N/A	N/A	N/A	N/A	SE UKS 030 AA
<input checked="" type="checkbox"/>	Mounting Device	SCHMID	Holder	N/A	N/A	SD000H01KA
<input checked="" type="checkbox"/>	Twin SAM Phantom	SCHMID	QD000P40CD	N/A	N/A	1679
<input type="checkbox"/>	Triple Modular Phantom	SCHMID	QD000P51CA	N/A	N/A	1147
<input checked="" type="checkbox"/>	DataAcquisition Electronics	SCHMID	DAE4	2014-07-22	2015-07-22	1394
<input checked="" type="checkbox"/>	Dosimetric E-Field Probe	SCHMID	ES3DV3	2015-03-24	2016-03-24	3328
<input checked="" type="checkbox"/>	Dosimetric E-Field Probe	SCHMID	EX3DV4	2014-07-22	2015-07-22	3930
<input type="checkbox"/>	Dummy Probe	N/A	N/A	N/A	N/A	N/A
<input checked="" type="checkbox"/>	835MHz SAR Dipole	SCHMID	D835V2	2014-11-19	2016-11-19	4d159
<input checked="" type="checkbox"/>	1800MHz SAR Dipole	SCHMID	D1800V2	2014-07-18	2016-07-18	2d047
<input checked="" type="checkbox"/>	1900MHz SAR Dipole	SCHMID	D1900V2	2014-11-14	2016-11-14	5d176
<input checked="" type="checkbox"/>	2450MHz SAR Dipole	SCHMID	D2450V2	2014-11-19	2016-11-19	920
<input checked="" type="checkbox"/>	2600 MHz SAR Dipole	SCHMID	D2600V2	2015-03-02	2017-03-02	1103
<input checked="" type="checkbox"/>	Network Analyzer	Agilent	E5071C	2014-10-21	2015-10-21	MY46106970
<input checked="" type="checkbox"/>	Signal Generator	Agilent	ESG-3000A	2014-06-26	2015-06-26	US37230529
<input checked="" type="checkbox"/>	Amplifier	EMPOWER	BBS3Q7ELU	2014-09-12	2015-09-12	1020
<input checked="" type="checkbox"/>	Amplifier	RFBAY Inc.	MPA-40-40	2015-05-08	2016-05-08	21151801
<input type="checkbox"/>	High Power RF Amplifier	EMPOWER	BBS3Q8CCJ	2014-10-20	2015-10-20	1005
<input checked="" type="checkbox"/>	Power Meter	HP	EPM-442A	2015-02-26	2016-02-26	GB37170267
<input checked="" type="checkbox"/>	Power Meter	Anritsu	ML2495A	2014-10-07	2015-10-07	1435003
<input checked="" type="checkbox"/>	Wide Bandwidth Power Sensor	Anritsu	MA2490A	2014-10-07	2015-10-07	1409034
<input checked="" type="checkbox"/>	Power Sensor	HP	8481A	2015-02-26	2016-02-26	3318A96566
<input checked="" type="checkbox"/>	Power Sensor	HP	8481A	2015-02-06	2016-02-06	2702A65976
<input checked="" type="checkbox"/>	Dual Directional Coupler	Agilent	778D-012	2015-01-06	2016-01-06	50228
<input checked="" type="checkbox"/>	Directional Coupler	HP	773D	2014-06-27	2015-06-27	2389A00640
<input checked="" type="checkbox"/>	Low Pass Filter 1.5GHz	Micro LAB	LA-15N	2014-09-11	2015-09-11	N/A
<input checked="" type="checkbox"/>	Low Pass Filter 3.0GHz	Micro LAB	LA-30N	2014-09-11	2015-09-11	N/A
<input checked="" type="checkbox"/>	Attenuators(3 dB)	Agilent	8491B	2014-06-27	2015-06-27	MY39260700
<input checked="" type="checkbox"/>	Attenuators(10 dB)	WEINSCHEL	23-10-34	2015-01-06	2016-01-06	BP4387
<input type="checkbox"/>	Step Attenuator	HP	8494A	2014-09-11	2015-09-11	3308A33341
<input checked="" type="checkbox"/>	Dielectric Probe kit	SCHMID	DAK-3.5	2014-12-09	2015-12-09	1092
<input checked="" type="checkbox"/>	8960 Series 10 Wireless Comms. Test Set	Agilent	E5515C	2014-09-12	2015-09-12	GB41321164
<input checked="" type="checkbox"/>	Wideband Radio Communication Tester	Rohde Schwarz	CMW500	2014-09-18	2015-09-18	101414
<input checked="" type="checkbox"/>	Power Splitter	Anritsu	K241B	2014-10-21	2015-10-21	1701102
<input checked="" type="checkbox"/>	Bluetooth Tester	TESCOM	TC-3000B	2014-06-26	2015-06-26	3000B640046

NOTE:The E-field probe was calibrated by SPEAG, by temperature measurement procedure. Dipole Verification measurement is performed by DT&C before each test. The brain and muscle simulating material are calibrated by DT&C using the dielectric probe system and network analyzer to determine the conductivity and permittivity (dielectric constant) of the brain-equivalent material. Each equipment item was used solely within its respective calibration period.

4. TEST SYSTEM SPECIFICATIONS

Automated TEST SYSTEM SPECIFICATIONS:

Positioner

Robot	StäubliUnimation Corp. Robot Model: TX60L
Repeatability	0.02 mm
No. of axis	6

Data Acquisition Electronic (DAE) System

Cell Controller

Processor	Intel Core i7-2600
Clock Speed	3.40 GHz
Operating System	Windows 7 Professional
Data Card	DASY5 PC-Board

Data Converter

Features	Signal, multiplexer, A/D converter. & control logic
Software	DASY5
Connecting Lines	Optical downlink for data and status info Optical uplink for commands and clock

PC Interface Card

Function	24 bit (64 MHz) DSP for real time processing Link to DAE 4 16 bit A/D converter for surface detection system serial link to robot direct emergency stop output for robot
-----------------	--

E-Field Probes

Model	EX3DV4 S/N: 3930, ES3DV3 S/N: 3328
Construction	Triangular core fiber optic detection system
Frequency	10 MHz to 6 GHz, 10 MHz to 3 GHz
Linearity	± 0.2 dB (30 MHz to 6 GHz), ± 0.2 dB (30 MHz to 3 GHz)

Phantom

Phantom	SAM Twin Phantom (V5.0)
Shell Material	Composite
Thickness	2.0 ± 0.2 mm

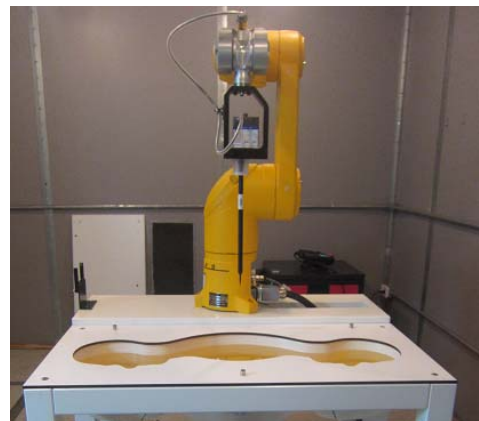

Figure 2.2 DASY5 Test System

5. SAR MEASUREMENT PROCEDURE

5.1 Measurement Procedure

The evaluation was performed using the following procedure compliant to FCC KDB Publication 865664 D01v01r03 and IEEE 1528-2013:

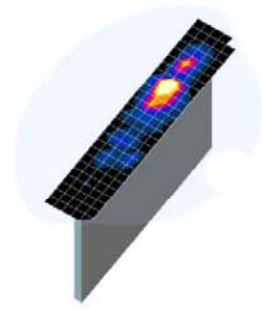

Figure 5.1
Sample SAR Area Scan

1. The SAR distribution at the exposed side of the head or body was measured at a distance no greater than 5.0 mm from the inner surface of the shell. The area covered the entire dimension of the device-head and body interface and the horizontal grid resolution was determined per FCC KDB Publication 865664 D01v01r03 (See Table 5-1) and IEEE 1528-2013.
2. The point SAR measurement was taken at the maximum SAR region determined from Step 1 to enable the monitoring of SAR fluctuations/drifts during the 1g/10g cube evaluation. SAR at this fixed point was measured and used as a reference value.
3. Based on the area scan data, the peak of the region with maximum SAR was determined by spline interpolation. Around this point, a volume was assessed according to the measurement resolution and volume size requirements of FCC KDB Publication 865664 D01v01r03 (See Table 5-1) and IEEE 1528-2013. On the basis of this data set, the spatial peak SAR value was evaluated with the following procedure (see references or the DASY manual online for more details):
 - a. SAR values at the inner surface of the phantom are extrapolated from the measured values along the line away from the surface with spacing no greater than that in Table 3-1. The extrapolation was based on a least-squares algorithm. A polynomial of the fourth order was calculated through the points in the z-axis (normal to the phantom shell).
 - b. After the maximum interpolated values were calculated between the points in the cube, the SAR was averaged over the spatial volume (1g or 10g) using a 3D-Spline interpolation algorithm. The 3D-spline is composed of three one-dimensional splines with the “Not a knot” condition (in x, y, and z directions). The volume was then integrated with the trapezoidal algorithm. One thousand points (10 x 10 x 10) were obtained through interpolation, in order to calculate the averaged SAR.
 - c. All neighboring volumes were evaluated until no neighboring volume with a higher average value was found.
4. The SAR reference value, at the same location as step 2, was re-measured after the zoom scan was complete to calculate the SAR drift. If the drift deviated by more than 5%, the SAR test and drift measurements were repeated.

Frequency	Maximum Area Scan Resolution (mm) ($\Delta x_{area}, \Delta y_{area}$)	Maximum Zoom Scan Resolution (mm) ($\Delta x_{zoom}, \Delta y_{zoom}$)	Maximum Zoom Scan Spatial Resolution (mm)			Minimum Zoom Scan Volume (mm) (x, y, z)
			Uniform Grid	Graded Grid		
			$\Delta z_{zoom}(n)$	$\Delta z_{zoom}(1)^*$	$\Delta z_{zoom}(n>1)^*$	
≤ 2 GHz	≤ 15	≤ 8	≤ 5	≤ 4	≤ 1.5 * $\Delta z_{zoom}(n-1)$	≥ 30
2-3 GHz	≤ 12	≤ 5	≤ 5	≤ 4	≤ 1.5 * $\Delta z_{zoom}(n-1)$	≥ 30
3-4 GHz	≤ 12	≤ 5	≤ 4	≤ 3	≤ 1.5 * $\Delta z_{zoom}(n-1)$	≥ 28
4-5 GHz	≤ 10	≤ 4	≤ 3	≤ 2.5	≤ 1.5 * $\Delta z_{zoom}(n-1)$	≥ 25
5-6 GHz	≤ 10	≤ 4	≤ 2	≤ 2	≤ 1.5 * $\Delta z_{zoom}(n-1)$	≥ 22

Table 5.1 Area and Zoom Scan Resolutions per FCC KDB Publication 865664 D01v01r03*

*Also compliant to IEEE 1528-2013 Table 6

6. DEFINITION OF REFERENCE POINTS

6.1 Ear Reference Point

Figure 6.1 shows the front, back and side views of the SAM Twin Phantom. The point “M” is the reference point for the center of the mouth, “LE” is the left ear reference point(ERP), and “RE” is the right ERP. The ERPs are 15mm posterior to the entrance to the Ear canal (EEC) along the B-M line (Back-Mouth), as shown in Figure 6.5. The plane Passing, through the two ear canals and M is defined as the Reference Plane. The line N-F (Neck- Front) is perpendicular to the reference plane and passing through the RE (or LE) is called the Reference Pivoting Line (see Figure 6.1). Line B-M is perpendicular to the N-F line. Both N-F and B-M lines are marked on the external phantom shell to facilitate handset positioning.

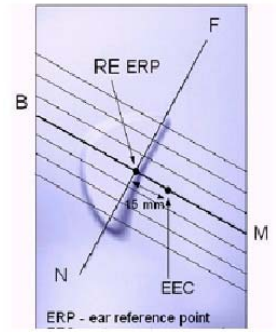

Figure 6.1
Close-up side view of ERP

6.2 Handset Reference Points

Two imaginary lines on the handset were established: the vertical centerline and the horizontal line. The test device was placed in a normal operating position with the “testdevice reference point” located along the “vertical centerline” on the front of the device aligned to the “ear reference point” (See Fig. 6.3). The “test device reference point” was then located at the same level as the center of the ear reference point. The test device was positioned so that the “vertical centerline” was bisecting the front surface of the handset at it’s top and bottom edges, positioning the “ear reference point” on the outer surface of the both the left and right head phantoms on the ear reference point.



Figure 6.2 Front, back and side view SAM Twin Phantom

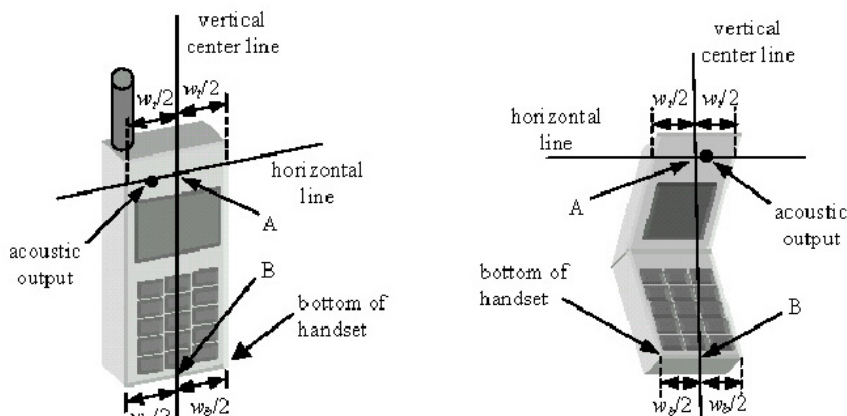

Figure 6.3 Handset Vertical Center & Horizontal Line Reference Points

7. TEST CONFIGURATION POSITIONS FOR HANDSETS

7.1 Device Holder

The device holder is made out of low-loss POM material having the following dielectric parameters: relative permittivity $\epsilon = 3$ and loss tangent $\delta = 0.02$.

7.2 Positioning for Cheek/Touch

1. The test device was positioned with the handset close to the surface of the phantom such that point A is on the (virtual) extension of the line passing through points RE and LE on the phantom (see Figure 7.1), such that the plane defined by the vertical center line and the horizontal line of the phone is approximately parallel to the sagittal plane of the phantom.

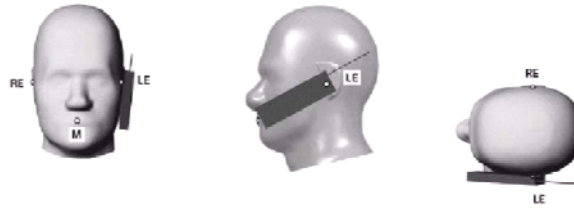

Figure 7.1 Front, Side and Top View of Cheek/Touch Position

2. The handset was translated towards the phantom along the line passing through RE & LE until the handset touches the ear.
3. While maintaining the handset in this plane, the handset was rotated around the LE-RE line until the vertical centerline was in the plane normal to MB-NF including the line MB (reference plane).
4. The phone was then rotated around the vertical centerline until the phone (horizontal line) was symmetrical with respect to the line NF.
5. While maintaining the vertical centerline in the reference plane, keeping point A on the line passing through RE and LE, and maintaining the phone contact with the ear, the handset was rotated about the line NF until any point on the handset made contact with a phantom point below the ear (cheek). (See Figure 7.2)

7.3 Positioning for Ear / 15 ° Tilt

With the test device aligned in the "Cheek/Touch Position":

1. While maintaining the orientation of the phone, the phone was retracted parallel to the reference plane far enough to enable a rotation of the phone by 15 degree.
2. The phone was then rotated around the horizontal line by 15 degree.
3. While maintaining the orientation of the phone, the phone was moved parallel to the reference plane until any part of the phone touches the head. (In this position, point A was located on the line RE-LE). The tilted position is obtained when the contact is on the pinna. If the contact was at any location other than the pinna, the angle of the phone would then be reduced. The tilted position was obtained when any part of the phone was in contact of the ear as well as a second part of the phone was in contact with the head (see Figure 7.3).

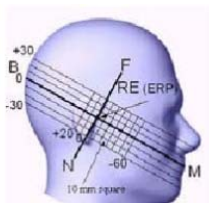

Figure 7.2 Side view w/ relevant markings

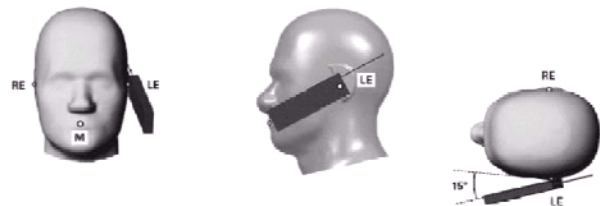

Figure 7.3 Front, Side and Top View of Ear/15° Position

7.4 Body-Worn Accessory Configurations

Body-worn operating configurations are tested with the belt-clips and holsters attached to the device and positioned against a flat phantom in a normal use configuration (see Figure 6.7). Per FCC KDB Publication 648474 D04v01r02, Body-worn accessory exposure is typically related to voice mode operations when handsets are carried in body-worn accessories. The body-worn accessory procedures in FCC KDB Publication 447498 D01v05r02 should be used to test for body-worn accessory SAR compliance, without a headset connected to it. This enables the test results for such configuration to be compatible with that required for hotspot mode when the body-worn accessory test separation distance is greater than or equal to that required for hotspot mode, when applicable. When the reported SAR for a body-worn accessory, measured without a headset connected to the handset, is > 1.2 W/kg, the highest reported SAR configuration for that wireless mode and frequency band should be repeated for that body-worn accessory with a headset attached to the handset.

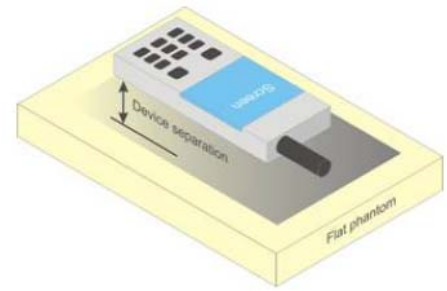

Figure 6.7 Sample Body-Worn Diagram

Accessories for Body-worn operation configurations are divided into two categories: those that do not contain metallic components and those that do contain metallic components. When multiple accessories that do not contain metallic components are supplied with the device, the device is tested with only the accessory that dictates the closest spacing to the body. Then multiple accessories that contain metallic components are tested with the device with each accessory. If multiple accessories share an identical metallic component (i.e. the same metallic belt-clip used with different holsters with no other metallic components) only the accessory that dictates the closest spacing to the body is tested.

Body-worn accessories may not always be supplied or available as options for some devices intended to be authorized for body-worn use. In this case, a test configuration with a separation distance between the back of the device and the flat phantom is used. Test position spacing was documented.

Transmitters that are designed to operate in front of a person's face, as in push-to-talk configurations, are tested for SAR compliance with the front of the device positioned to face the flat phantom in head fluid. For devices that are carried next to the body such as a shoulder, waist or chest-worn transmitters, SAR compliance is tested with the accessories, including headsets and microphones, attached to the device and positioned against a flat phantom in a normal use configuration.

7.5 Extremity Exposure Configurations

Devices that are designed or intended for use on extremities or mainly operated in extremity only exposure conditions; i.e., hands, wrists, feet and ankles, may require extremity SAR evaluation. When the device also operates in close proximity to the user's body, SAR compliance for the body is also required. The 1-g body and 10-g extremity SAR Exclusion Thresholds found in KDB Publication 447498 D01v05r02 should be applied to determine SAR test requirements.

Per KDB Publication 447498 D01v05r02, Cell phones (handsets) are not normally designed to be used on extremities or operated in extremity only exposure conditions. The maximum output power levels of handsets generally do not require extremity SAR testing to show compliance. Therefore, extremity SAR was not evaluated for this device.

7.6 Wireless Router Configurations

Some battery-operated handsets have the capability to transmit and receive user data through simultaneous transmission of WIFI simultaneously with a separate licensed transmitter. The FCC has provided guidance in FCC KDB Publication 941225 D06v02 where SAR test considerations for handsets ($L \times W \geq 9 \text{ cm} \times 5 \text{ cm}$) are based on a composite test separation distance of 10 mm from the front, back and edges of the device containing transmitting antennas within 2.5 cm of their edges, determined from general mixed use conditions for this type of devices. Since the hotspot SAR results may overlap with the body-worn accessory SAR requirements, the more conservative configurations can be considered, thus excluding some body-worn accessory SAR tests.

When the user enables the personal wireless router functions for the handset, actual operations include simultaneous transmission of both the WIFI transmitter and another licensed transmitter. Both transmitters often do not transmit at the same transmitting frequency and thus cannot be evaluated for SAR under actual use conditions due to the limitations of the SAR assessment probes.

Therefore, SAR must be evaluated for each frequency transmission and mode separately and spatially summed with the WIFI transmitter according to FCC KDB Publication 447498 D01v05r02 publication procedures. The "Portable Hotspot" feature on the handset was NOT activated during SAR assessments, to ensure the SAR measurements were evaluated for a single transmission frequency RF signal at a time.

8. RF EXPOSURE LIMITS

Uncontrolled Environment:

UNCONTROLLED ENVIRONMENTS are defined as locations where there is the exposure of individuals who have no knowledge or control of their exposure. The general population/uncontrolled exposure limits are applicable to situations in which the general public may be exposed or in which persons who are exposed as a consequence of their employment may not be made fully aware of the potential for exposure or cannot exercise control over their exposure. Members of the general public would come under this category when exposure is not employment-related; for example, in the case of a wireless transmitter that exposes persons in its vicinity.

Controlled Environment:

CONTROLLED ENVIRONMENTS are defined as locations where there is exposure that may be incurred by persons who are aware of the potential for exposure, (i.e. as a result of employment or occupation). In general, occupational/controlled exposure limits are employment, who have been made fully aware of the potential for exposure and can exercise control over their exposure. This exposure category is also applicable when the exposure is of a transient nature due to incidental passage through a location where the exposure levels may be higher than the general population/uncontrolled limits, but the exposed person is fully aware of the potential for exposure and can exercise control over his or her exposure by leaving the area or by some other appropriate means.

Table 8.1.SAR Human Exposure Specified in ANSI/IEEE C95.1-2005

	HUMAN EXPOSURE LIMITS	
	General Public Exposure (W/kg) or (mW/g)	Occupational Exposure (W/kg) or (mW/g)
SPATIAL PEAK SAR * (Brain)	1.60	8.00
SPATIAL AVERAGE SAR ** (Whole Body)	0.08	0.40
SPATIAL PEAK SAR *** (Hands / Feet / Ankle / Wrist)	4.00	20.0

1. The Spatial Peak value of the SAR averaged over any 1 gram of tissue (defined as a tissue volume in the shape of a cube) and over the appropriate averaging time.
2. The Spatial Average value of the SAR averaged over the whole body.
3. The Spatial Peak value of the SAR averaged over any 10 grams of tissue (defined as a tissue volume in the shape of a cube) and over the appropriate averaging time.

Uncontrolled Environments are defined as locations where there is the exposure of individuals who have no knowledge or control of their exposure.

Controlled Environments are defined as locations where there is exposure that may be incurred by persons who are aware of the potential for exposure, (i.e.as a result of employment or occupation).

9. FCC MEASUREMENT PROCEDURES

Power measurements were performed using a base station simulator under digital average power.

9.1 Measured and Reported SAR

Per FCC KDB Publication 447498 D01v05r02, When SAR is not measured at the maximum power level allowed for production units, the results must be scaled to the maximum tune-up tolerance limit according to the power applied to the individual channels tested to determine compliance. For simultaneous transmission, the measured aggregate SAR must be scaled according to the sum of the differences between the maximum tune-up tolerance and actual power used to test each transmitter. When SAR is measured at or scaled to the maximum tune-up tolerance limit, the results are referred to as reported SAR. The highest reported SAR results are identified on the grant of equipment authorization according to procedures in KDB 690783 D01v01r03.

9.2 Procedures Used to Establish RF Signal for SAR

The following procedures are according to FCC KDB Publication 941225 D01 "SAR Measurement Procedures" v03, October 2014.

The device was placed into a simulated call using a base station simulator in a RF shielded chamber. Establishing connections in this manner ensure a consistent means for testing SAR and are recommended for evaluating SAR [4]. Devices under test were evaluated prior to testing, with a fully charged battery and were configured to operate at maximum output power. In order to verify that the device was tested throughout the SAR test at maximum output power, the SAR measurement system measures a "point SAR" at an arbitrary reference point at the start and end of the 1 gram SAR evaluation, to assess for any power drifts during the evaluation. If the power drift deviated by more than 5%, the SAR test and drift measurements were repeated.

9.3 SAR Measurement Conditions for WCDMA (UMTS)

9.3.1 Output Power Verification

Maximum output power is measured on the High, Middle and Low channels for each applicable transmission band according to the general descriptions in section 5.2 of 3GPP TS 34.121, using the appropriate RMC or AMR with TPC (transmit power control) set to all "1s".

Maximum output power is verified on the High, Middle and Low channels according to the general, descriptions in section 5.2 of 3GPP TS 34.121 (release 5), using the appropriate RMC with TPC, (transmit power control) set to all "1s" or applying the required inner loop power control procedures to maintain maximum output power while HSUPA is active. Results for all applicable physical channel configurations (DPCCH, DPDCHn and spreading codes, HS-DPCCH etc) are tabulated in this test report. All configurations that are not supported by the DUT or cannot be measured due to technical or equipment limitations are identified.

9.3.2 Head SAR Measurements for Handsets

SAR for head exposure configurations is measured using the 12.2 kbps RMC with TPC bits configured to all "1s". SAR in AMR configurations is not required when the maximum average output of each RF channel for 12.2 kbps AMR is less than 0.25 dB higher than that measured in 12.2 kbps RMC. Otherwise, SAR is measured on the maximum output channel in 12.2 AMR with a 3.4 kbps SRB (signaling radio bearer) using the exposure configuration that resulted in the highest SAR for that RF channel in the 12.2 kbps RMC mode.

9.3.3 Body SAR Measurements

SAR for body exposure configurations is measured using the 12.2 kbps RMC with the TPC bits all "1s".

9.3.4 Release 5 HSDPA Data Devices

The following procedures are applicable to HSDPA data devices operating under 3GPP Release 5. SAR is required for devices in body-worn accessory and other body exposure conditions, including handsets and data modems operating in various electronic devices. HSDPA operates in conjunction with WCDMA and requires an active DPCCH. The default test configuration is to measure SAR in WCDMA with HSDPA remain inactive, to establish a radio link between the test device and a communication test set using a 12.2 kbps RMC configured in Test Loop Mode 1. SAR for HSDPA is selectively measured using the highest reported SAR configuration in WCDMA, with an FRC in H-set 1 and a 12.2 kbps RMC. SAR is selectively confirmed for other physical channel configurations (DPCCH & DPDCHn) according to exposure conditions, device operating capabilities and maximum output power specified for production units, including tune-up tolerance by applying the 3G SAR test reduction procedures. Maximum output power is verified according to the applicable versions of 3GPP TS 34.121. SAR must be measured based on these maximum output conditions and requirements in KDB Publication 447498, with respect to the UE Categories, and explained in the SAR report. When Maximum Power Reduction (MPR) applies, the implementations must be clearly identified in the SAR report to support test results according to Cubic Metric (CM) and, as appropriate, Enhanced MPR (E-MPR) requirements.

Sub-test	β_c	β_d	β_d (SF)	β_c/β_d	$\beta_{hs}^{(1)}$	CM (dB) ⁽²⁾
1	2/15	15/15	64	2/15	4/15	0.0
2	12/15 ⁽³⁾	15/15 ⁽³⁾	64	12/15 ⁽³⁾	24/15	1.0
3	15/15	8/15	64	15/8	30/15	1.5
4	15/15	4/15	64	15/4	30/15	1.5

Note 1: $\Delta_{ACK}, \Delta_{NACK}$ and $\Delta_{CQI} = 8 \Leftrightarrow A_{hs} = \beta_{hs}/\beta_c = 30/15 \Leftrightarrow \beta_{hs} = 30/15 * \beta_c$
 Note 2: CM = 1 for $\beta_c/\beta_d = 12/15, \beta_{hs}/\beta_c = 24/15$.
 Note 3: For subtest 2 the β_c/β_d ratio of 12/15 for the TFC during the measurement period (TF1, TF0) is achieved by setting the signaled gain factors for the reference TFC (TF1, TF1) to $\beta_c = 11/15$ and $\beta_d = 15/15$.

Figure 9.1 Table 1

9.3.5 Release 6 HSUPA Data Devices

The following procedures are applicable to HSPA (HSUPA/HSDPA) data devices operating under 3GPP Release 6. SAR is required for devices in body-worn accessory and other body exposure conditions, including handsets and data modems operating in various electronic devices. HSUPA operates in conjunction with WCDMA and HSDPA. SAR is initially measured in WCDMA test configurations with HSPA remain inactive. The default test configuration is to establish a radio link between the test device and a communication test set to configure a 12.2 kbps RMC in Test Loop Mode 1. SAR for HSPA is selectively measured with HS-DPCCH, E-DPCCH and E-DPDCH, all enabled, along with a 12.2 kbps RMC using the highest reported SAR configuration in WCDMA with 12.2 kbps RMC only.

An FRC is configured according to HS-DPCCH Sub-test 1 using H-set 1 and QPSK. HSPA is configured according to E-DCH Sub-test 5 requirements. SAR for other HSPA sub-test configurations is confirmed selectively according to exposure conditions, E-DCH UE Category and maximum output power of production units, including tune-up tolerance by applying the 3G SAR test reduction procedure. Maximum output power is verified according to procedures in applicable versions of 3GPP TS 34.121. SAR must be measured based on these maximum output conditions and requirements in KDB Publication 447498, with respect to the UE Categories for HS-DPCCH and HSPA, and explained in the SAR report. When Maximum Power Reduction (MPR) applies, the implementations must be clearly identified in the SAR report to support test results according to Cubic Metric (CM) and, as appropriate, Enhanced MPR (E-MPR) requirements.

Sub-test	β_c	β_d	β_d (SF)	β_c/β_d	$\beta_{hs}^{(1)}$	β_{ec}	β_{ed}	β_{ed} (SF)	β_{ed} (codes)	CM ⁽²⁾ (dB)	MPR (dB)	AG ⁽⁴⁾ Index	E-TFCI
1	11/15 ⁽³⁾	15/15 ⁽³⁾	64	11/15 ⁽³⁾	22/15	209/225	1039/225	4	1	1.0	0.0	20	75
2	6/15	15/15	64	6/15	12/15	12/15	94/75	4	1	3.0	2.0	12	67
3	15/15	9/15	64	15/9	30/15	30/15	$\beta_{ed}: 47/15$ $\beta_{ed}: 47/15$	4	2	2.0	1.0	15	92
4	2/15	15/15	64	2/15	4/15	2/15	56/75	4	1	3.0	2.0	17	71
5	15/15 ⁽⁴⁾	15/15 ⁽⁴⁾	64	15/15 ⁽⁴⁾	30/15	24/15	134/15	4	1	1.0	0.0	21	81

Note 1: Δ_{ACK} , Δ_{NACK} and $\Delta_{CQI} = 8 \Leftrightarrow A_{hs} = \beta_{hs}/\beta_c = 30/15 \Leftrightarrow \beta_{hs} = 30/15 * \beta_c$.
Note 2: CM = 1 for $\beta_c/\beta_d = 12/15$, $\beta_{hs}/\beta_c = 24/15$. For all other combinations of DPDCH, DPCCCH, HS-DPCCH, E-DPDCH and E-DPCCH the MPR is based on the relative CM difference.
Note 3: For subtest 1 the β_c/β_d ratio of 11/15 for the TFC during the measurement period (TF1, TF0) is achieved by setting the signaled gain factors for the reference TFC (TF1, TF1) to $\beta_c = 10/15$ and $\beta_d = 15/15$.
Note 4: For subtest 5 the β_c/β_d ratio of 15/15 for the TFC during the measurement period (TF1, TF0) is achieved by setting the signaled gain factors for the reference TFC (TF1, TF1) to $\beta_c = 14/15$ and $\beta_d = 15/15$.
Note 5: Testing UE using E-DPDCH Physical Layer category 1 Sub-test 3 is not required according to TS 25.306 Table 5.1g.
Note 6: β_{ed} cannot be set directly; it is set by Absolute Grant Value.

Figure 9.2 Table 2

9.3.6 SAR Measurements Conditions for DC-HSDPA

This device supports DC-HSDPA Rx only and DC-HSDPA SAR was not required according to the following 3G SAR reduction procedure and HSPA, HSPA+ and DC-HSDPA SAR Guidance of KDB 941225 D01v02.

In the following procedures, the mode tested for SAR is referred to as the primary mode. The equivalent modes considered for SAR test reduction are denoted as secondary modes. Both primary and secondary modes must be in the same frequency band. When the maximum output power and tune-up tolerance specified for production units in a secondary mode is $\leq 1/4$ dB higher than the primary mode or when the highest reported SAR of the primary mode is scaled by the ratio of specified maximum output power and tune-up tolerance of secondary to primary mode and the adjusted SAR is ≤ 1.2 W/kg, SAR measurement is not required for the secondary mode. This is referred to as the 3G SAR test reduction procedure in the following SAR test guidance, where the primary mode is identified in the applicable wireless mode test procedures and the secondary mode is wireless mode being considered for SAR test reduction by that procedure. When the 3G SAR test reduction procedure is not satisfied, it is identified as "otherwise" in the applicable procedures; SAR measurement is required for the secondary mode.

SAR is required for Rel. 8 DC-HSDPA when SAR is required for Rel. 5 HSDPA; otherwise, the 3G SAR test reduction procedure is applied to DC-HSDPA with 12.2 kbps RMC as the primary mode. Power is measured for DC-HSDPA according to the H-Set 12, FRC configuration in Table C.8.1.12 of 3GPP TS 34.121-1 to determine SAR test reduction. A primary and a secondary serving HS-DSCH Cell are required to perform the power measurement and for the results to be acceptable.

9.4 SAR Measurement Conditions for LTE

LTE modes were tested according to FCC KDB 941225 D05v02 publication. Please see notes after the tabulated SAR data for required test configurations. Establishing connections with base station simulators ensure a consistent means for testing SAR and are recommended for evaluating SAR. The R&S CMW500 was used for LTE output power measurement and SAR testing. Closed loop power control was used so the UE transmits with maximum output power during SAR testing. SAR tests were performed with the same number of RB and RB offsets transmitting on all TTI frames (maximum TTI).

9.4.1 Spectrum Plots for RB Configurations

A properly configured base station simulator was used for SAR tests and power measurements. Therefore, spectrum plots for RB configurations were not required to be included in this report.

9.4.2 MPR

MPR is permanently implemented for this device by the manufacturer. The specific manufacturer target MPR is indicated alongside the SAR results. MPR is enabled for this device, according to 3GPP TS36. 101 Section 6.2.3 – 6.2.5 under Table 6.2.3-1.

9.4.3 A-MPR

This device supports A-MPR.

A-MPR is disabled for all SAR tests by setting NS=01 on the base station simulator.

9.4.4 Required RB Size and RB Offsets for SAR Testing

According to FCC KDB 941225 D05v02r03:

- a. Per Section 4.2.1, SAR is required for QPSK 1 RB Allocation for the largest bandwidth
 - i. The required channel and offset combination with the highest maximum output power is required for SAR.
 - ii. When the reported SAR is ≤ 0.8 W/kg, testing of the remaining RB offset configurations and required test channel is not required. Otherwise, SAR is required for the remaining required test channels using the RB offset configuration with highest output power for that channel.
 - iii. When the reported SAR for a required test channel is > 1.45 W/kg, SAR is required for all RB offset configurations for that channel.
- b. Per Section 4.2.2, SAR is required for 50% RB allocation using the largest bandwidth following the same procedures outlined in Section 4.2.1.
- c. Per Section 4.2.3, QPSK SAR is not required for the 100% allocation when the highest maximum output power for the 100% allocation is less than the highest maximum output power of the 1 RB and 50% RB allocations and the reported SAR for the 1 RB and 50% RB allocations is < 0.8 W/kg.
- d. Per Section 4.2.4 and 4.3, SAR tests for higher order modulations and lower bandwidths configurations are not required when the conducted power of the required test configurations determined by Sections 4.2.1 through 4.2.3 is less than or equal to 0.5 dB higher than the equivalent configuration using QPSK modulation and when the QPSK SAR for those configurations is < 1.45 W/kg.

9.5 SAR Testing with 802.11 Transmitters

Normal network operating configurations are not suitable for measuring the SAR of 802.11 b/g/n transmitters. Unpredictable fluctuations in network traffic and antenna diversity conditions can introduce undesirable variations in SAR results. The SAR for these devices should be measured using chipset based test mode software to ensure the results are consistent and reliable. See KDB Publication 248227D01v02 for more details.

9.5.1 General Device Setup

Chipset based test mode software is hardware dependent and generally varies among manufacturers. The device operating parameters established in test mode for SAR measurements must be identical to those programmed in production units, including output power levels, amplifier gain settings and other RF performance tuning parameters. The test frequencies should correspond to actual channel frequencies defined for domestic use. SAR for devices with switched diversity should be measured with only one antenna transmitting at a time during each SAR measurement, according to a fixed modulation and data rate. The same data pattern should be used for all measurements.

9.5.2 Frequency Channel Configurations

For 2.4 GHz, the highest average RF output power channel between the low, mid and high channel at the lowest data rate was selected for SAR evaluation in 802.11b mode. 802.11g/n modes and higher data rates for 802.11b were additionally evaluated for SAR if the output power of the respective mode was 0.25 dB or higher than the powers of the SAR configurations tested in the 802.11b mode.

If the maximum extrapolated peak SAR of the zoom scan for the highest output channel was less than 1.6 W/kg and if the 1g averaged SAR was less than 0.8 W/kg, SAR testing was not required for the other test channels in the band.

10. RF CONDUCTED POWERS

10.1 GSM Conducted Powers

Band	Channel	Maximum Burst-Averaged Output Power (dBm)								
		Voice	GPRS/EDGE Data (GMSK)				EDGE Data (8-PSK)			
		GSM CS 1 Slot	GPRS 1 TX Slot	GPRS 2 TX Slot	GPRS 3 TX Slot	GPRS 4 TX Slot	EDGE 1 TX Slot	EDGE 2 TX Slot	EDGE 3 TX Slot	EDGE 4 TX Slot
GSM850	128	33.6	33.6	30.4	29.2	27.7	27.1	24.6	23.1	21.6
	190	33.6	33.6	30.4	29.1	27.6	27.1	24.7	23.2	21.6
	251	33.7	33.7	30.5	29.2	27.7	27.2	24.7	23.2	21.7
PCS 1900	512	30.5	30.5	27.4	25.8	24.4	25.6	23.7	22.1	20.7
	661	30.6	30.6	27.6	26.0	24.6	25.5	23.7	22.2	20.7
	810	30.5	30.5	27.3	25.8	24.5	25.4	23.7	22.0	20.6
Band	Channel	Calculated Maximum Frame-Averaged Output Power (dBm)								
		Voice	GPRS/EDGE Data (GMSK)				EDGE Data (8-PSK)			
		GSM CS 1 Slot	GPRS 1 TX Slot	GPRS 2 TX Slot	GPRS 3 TX Slot	GPRS 4 TX Slot	EDGE 1 TX Slot	EDGE 2 TX Slot	EDGE 3 TX Slot	EDGE 4 TX Slot
GSM850	128	24.57	24.57	24.38	24.94	24.69	18.07	18.58	18.84	18.59
	190	24.57	24.57	24.38	24.84	24.59	18.07	18.68	18.94	18.59
	251	24.67	24.67	24.48	24.94	24.69	18.17	18.68	18.94	18.69
PCS 1900	512	21.47	21.47	21.38	21.54	21.39	16.57	17.68	17.84	17.69
	661	21.57	21.57	21.58	21.74	21.59	16.47	17.68	17.94	17.69
	810	21.47	21.47	21.28	21.54	21.49	16.37	17.68	17.74	17.59
GSM850	Frame Avg. Targets:	24.67	24.67	24.68	24.94	24.69	18.17	18.68	18.94	18.69
PCS 1900		22.17	22.17	21.68	21.94	21.69	17.17	17.68	17.94	17.69

Table 10.1 The power was measured by E5515C

Note:

- Both burst-averaged and calculated frame-averaged powers are included. Frame-averaged power was calculated from the measured burst-averaged power by converting the slot powers into linear units and calculating the energy over 8 timeslots.
- The source-based frame-averaged output power was evaluated for all GPRS slot configurations. The configuration with the highest target frame averaged output power was evaluated for hotspot SAR. When the maximum frame-averaged powers are equivalent across two or more slots (within 0.25 dB), the configuration with the most number of time slots was tested.
- GPRS (GMSK) output powers were measured with coding scheme setting of 1 (CS1) on the base station simulator. CS1 was configured to measure GPRS output power measurements and SAR to ensure GMSK modulation in the signal. Our Investigation has shown that CS1 - CS4 settings do not have any impact on the output levels or modulation in the GPRS modes.
- EDGE (8-PSK) output powers were measured with MCS7 on the base station simulator. MCS7 coding scheme was used to measure the output powers for EDGE since investigation has shown that choosing MCS7 coding scheme will ensure 8-PSK modulation. It has been shown that MCS levels that produce 8PSK modulation do not have an impact on output power.

GPRS Multislot class: 33 (max 4 TX Uplink slots)
 EDGE Multislot class: 33 (max 4 TX Uplink slots)
 DTM Multislot Class: N/A



Figure 10.1 Power Measurement Setup

10.2 WCDMA Conducted Powers

3GPP Release Version	Mode	3GPP 34.121 Subtest	Cellular Band (dBm)			PCS Band (dBm)			3GPP MPR (dB)
			4132	4183	4233	9262	9400	9538	
99	WCDMA	12.2 kbps RMC	24.20	24.10	24.20	23.70	23.70	23.60	-
99		12.2 kbps AMR	24.16	24.11	24.15	23.65	23.67	23.60	-
5	HSDPA	Subtest 1	24.12	24.14	24.12	23.69	23.64	23.53	0
5		Subtest 2	24.14	24.09	24.13	23.68	23.66	23.55	0
5		Subtest 3	23.68	23.60	23.70	23.16	23.20	23.23	0.5
5		Subtest 4	23.60	23.60	23.70	23.15	23.23	23.19	0.5
6	HSUPA	Subtest 1	23.56	23.80	23.32	22.65	23.20	22.99	0
6		Subtest 2	22.54	22.73	22.70	21.92	21.73	22.20	2
6		Subtest 3	22.79	23.16	22.73	22.61	22.38	22.40	1
6		Subtest 4	22.50	22.94	22.55	22.23	22.10	22.16	2
6		Subtest 5	23.41	23.72	23.23	23.59	23.36	22.90	0
8	DC-HSDPA	Subtest 1	24.00	23.90	24.00	23.80	23.70	23.60	0
8		Subtest 2	23.90	23.90	24.00	23.70	23.70	23.60	0
8		Subtest 3	23.50	23.40	23.50	23.10	23.20	23.10	0.5
8		Subtest 4	23.40	23.40	23.50	23.20	23.20	23.20	0.5

Table 10.2 The power was measured by E5515C

WCDMA SAR was tested under RMC 12.2 kbps with HSPA Inactive per KDB Publication 941225 D01v03. HSPA SAR was not required since the average output power of the HSPA subtests was not more than 0.25 dB higher than the RMC level and SAR was less than 1.2 W/kg.

The manufacturer declares that the HSUPA, DC-HSDPA transmitter’s power will not exceed the R99 maximum transmit power in devices based on Qualcomm’s HSPA chipset solutions.

This device supported DC-HSDPA Rx only.



Figure 10.2 Power Measurement Setup

10.3 LTE Conducted Powers

1) LTE Band 17

Mode	Freq. (MHz)	Channel	LTE Band 17 Conducted Power- 10 MHz Bandwidth						
			Bandwidth (MHz)	Modulation	RB Size	RB Offset	Conducted Power(dBm)	MPRAllowed Per 3GPP(dB)	MPR (dB)
Low	709	23780	10	QPSK	1	0	23.40	0	0
	709	23780	10	QPSK	1	25	23.32	0	0
	709	23780	10	QPSK	1	49	23.60	0	0
	709	23780	10	QPSK	25	0	22.35	0-1	1
	709	23780	10	QPSK	25	12	22.36	0-1	1
	709	23780	10	QPSK	25	25	22.37	0-1	1
	709	23780	10	QPSK	50	0	22.30	0-1	1
	709	23780	10	16QAM	1	0	22.92	0-1	1
	709	23780	10	16QAM	1	25	22.85	0-1	1
	709	23780	10	16QAM	1	49	22.84	0-1	1
	709	23780	10	16QAM	25	0	21.46	0-2	2
	709	23780	10	16QAM	25	12	21.55	0-2	2
	709	23780	10	16QAM	25	25	21.46	0-2	2
	709	23780	10	16QAM	50	0	21.27	0-2	2
High	711	23800	10	QPSK	1	0	23.50	0	0
	711	23800	10	QPSK	1	25	23.43	0	0
	711	23800	10	QPSK	1	49	23.43	0	0
	711	23800	10	QPSK	25	0	22.30	0-1	1
	711	23800	10	QPSK	25	12	22.29	0-1	1
	711	23800	10	QPSK	25	25	22.19	0-1	1
	711	23800	10	QPSK	50	0	22.15	0-1	1
	711	23800	10	16QAM	1	0	22.77	0-1	1
	711	23800	10	16QAM	1	25	22.69	0-1	1
	711	23800	10	16QAM	1	49	22.65	0-1	1
	711	23800	10	16QAM	25	0	21.32	0-2	2
	711	23800	10	16QAM	25	12	21.42	0-2	2
	711	23800	10	16QAM	25	25	21.22	0-2	2
	711	23800	10	16QAM	50	0	21.22	0-2	2

Table 10.3.1 The power was measured by CMW500

Mode	Freq. (MHz)	Channel	LTE Band 17 Conducted Power– 5 MHz Bandwidth						
			Bandwidth (MHz)	Modulation	RB Size	RB Offset	Conducted Power(dBm)	MPRAllowed Per 3GPP(dB)	MPR (dB)
Low	706.5	23755	5	QPSK	1	0	23.44	0	0
	706.5	23755	5	QPSK	1	12	23.25	0	0
	706.5	23755	5	QPSK	1	24	23.18	0	0
	706.5	23755	5	QPSK	12	0	22.11	0-1	1
	706.5	23755	5	QPSK	12	6	22.18	0-1	1
	706.5	23755	5	QPSK	12	13	22.22	0-1	1
	706.5	23755	5	QPSK	25	0	22.23	0-1	1
	706.5	23755	5	16QAM	1	0	23.11	0-1	1
	706.5	23755	5	16QAM	1	12	23.04	0-1	1
	706.5	23755	5	16QAM	1	24	22.63	0-1	1
	706.5	23755	5	16QAM	12	0	21.14	0-2	2
	706.5	23755	5	16QAM	12	6	21.24	0-2	2
	706.5	23755	5	16QAM	12	13	21.16	0-2	2
	706.5	23755	5	16QAM	25	0	21.25	0-2	2
High	713.5	23825	5	QPSK	1	0	23.37	0	0
	713.5	23825	5	QPSK	1	12	23.16	0	0
	713.5	23825	5	QPSK	1	24	23.46	0	0
	713.5	23825	5	QPSK	12	0	22.15	0-1	1
	713.5	23825	5	QPSK	12	6	22.22	0-1	1
	713.5	23825	5	QPSK	12	13	22.29	0-1	1
	713.5	23825	5	QPSK	25	0	22.28	0-1	1
	713.5	23825	5	16QAM	1	0	22.66	0-1	1
	713.5	23825	5	16QAM	1	12	22.65	0-1	1
	713.5	23825	5	16QAM	1	24	22.71	0-1	1
	713.5	23825	5	16QAM	12	0	21.15	0-2	2
	713.5	23825	5	16QAM	12	6	21.24	0-2	2
	713.5	23825	5	16QAM	12	13	21.21	0-2	2
	713.5	23825	5	16QAM	25	0	21.41	0-2	2

Table 10.3.2The power was measured by CMW500

2) LTE Band 5

Mode	Freq. (MHz)	Channel	LTE Band 5 Conducted Power– 10 MHz Bandwidth						
			Bandwidth (MHz)	Modulation	RB Size	RB Offset	Conducted Power(dBm)	MPRAllowed Per 3GPP(dB)	MPR (dB)
Low	829	20450	10	QPSK	1	0	22.71	0	0
	829	20450	10	QPSK	1	25	22.79	0	0
	829	20450	10	QPSK	1	49	22.80	0	0
	829	20450	10	QPSK	25	0	21.48	0-1	1
	829	20450	10	QPSK	25	12	21.57	0-1	1
	829	20450	10	QPSK	25	25	21.70	0-1	1
	829	20450	10	QPSK	50	0	21.66	0-1	1
	829	20450	10	16QAM	1	0	22.12	0-1	1
	829	20450	10	16QAM	1	25	22.16	0-1	1
	829	20450	10	16QAM	1	49	22.44	0-1	1
	829	20450	10	16QAM	25	0	20.88	0-2	2
	829	20450	10	16QAM	25	12	20.69	0-2	2
	829	20450	10	16QAM	25	25	21.06	0-2	2
	829	20450	10	16QAM	50	0	20.65	0-2	2
High	844	20600	10	QPSK	1	0	22.79	0	0
	844	20600	10	QPSK	1	25	22.99	0	0
	844	20600	10	QPSK	1	49	23.10	0	0
	844	20600	10	QPSK	25	0	21.77	0-1	1
	844	20600	10	QPSK	25	12	21.80	0-1	1
	844	20600	10	QPSK	25	25	21.98	0-1	1
	844	20600	10	QPSK	50	0	21.96	0-1	1
	844	20600	10	16QAM	1	0	22.30	0-1	1
	844	20600	10	16QAM	1	25	22.56	0-1	1
	844	20600	10	16QAM	1	49	22.81	0-1	1
	844	20600	10	16QAM	25	0	20.92	0-2	2
	844	20600	10	16QAM	25	12	20.96	0-2	2
	844	20600	10	16QAM	25	25	21.31	0-2	2
	844	20600	10	16QAM	50	0	20.99	0-2	2

Table 10.3.3The power was measured by CMW500

Mode	Freq. (MHz)	Channel	LTE Band 5 Conducted Power- 5 MHz Bandwidth						
			Bandwidth (MHz)	Modulation	RB Size	RB Offset	Conducted Power(dBm)	MPRAllowed Per 3GPP(dB)	MPR (dB)
Low	826.5	20425	5	QPSK	1	0	22.49	0	0
	826.5	20425	5	QPSK	1	12	22.46	0	0
	826.5	20425	5	QPSK	1	24	22.46	0	0
	826.5	20425	5	QPSK	12	0	21.47	0-1	1
	826.5	20425	5	QPSK	12	6	21.35	0-1	1
	826.5	20425	5	QPSK	12	13	21.34	0-1	1
	826.5	20425	5	QPSK	25	0	21.36	0-1	1
	826.5	20425	5	16QAM	1	0	21.99	0-1	1
	826.5	20425	5	16QAM	1	12	21.92	0-1	1
	826.5	20425	5	16QAM	1	24	22.00	0-1	1
	826.5	20425	5	16QAM	12	0	20.55	0-2	2
	826.5	20425	5	16QAM	12	6	20.43	0-2	2
	826.5	20425	5	16QAM	12	13	20.77	0-2	2
	826.5	20425	5	16QAM	25	0	20.69	0-2	2
Mid	836.5	20525	5	QPSK	1	0	22.78	0	0
	836.5	20525	5	QPSK	1	12	22.70	0	0
	836.5	20525	5	QPSK	1	24	22.78	0	0
	836.5	20525	5	QPSK	12	0	21.78	0-1	1
	836.5	20525	5	QPSK	12	6	21.68	0-1	1
	836.5	20525	5	QPSK	12	13	21.67	0-1	1
	836.5	20525	5	QPSK	25	0	21.73	0-1	1
	836.5	20525	5	16QAM	1	0	22.19	0-1	1
	836.5	20525	5	16QAM	1	12	22.16	0-1	1
	836.5	20525	5	16QAM	1	24	22.35	0-1	1
	836.5	20525	5	16QAM	12	0	21.12	0-2	2
	836.5	20525	5	16QAM	12	6	21.01	0-2	2
	836.5	20525	5	16QAM	12	13	20.78	0-2	2
	836.5	20525	5	16QAM	25	0	20.98	0-2	2
High	846.5	20625	5	QPSK	1	0	22.72	0	0
	846.5	20625	5	QPSK	1	12	23.02	0	0
	846.5	20625	5	QPSK	1	24	23.10	0	0
	846.5	20625	5	QPSK	12	0	21.94	0-1	1
	846.5	20625	5	QPSK	12	6	22.14	0-1	1
	846.5	20625	5	QPSK	12	13	22.21	0-1	1
	846.5	20625	5	QPSK	25	0	22.08	0-1	1
	846.5	20625	5	16QAM	1	0	22.34	0-1	1
	846.5	20625	5	16QAM	1	12	22.60	0-1	1
	846.5	20625	5	16QAM	1	24	22.78	0-1	1
	846.5	20625	5	16QAM	12	0	21.07	0-2	2
	846.5	20625	5	16QAM	12	6	21.15	0-2	2
	846.5	20625	5	16QAM	12	13	21.42	0-2	2
	846.5	20625	5	16QAM	25	0	21.52	0-2	2

Table 10.3.4 The power was measured by CMW500

Mode	Freq. (MHz)	Channel	LTE Band 5 Conducted Power- 3 MHz Bandwidth						
			Bandwidth (MHz)	Modulation	RB Size	RB Offset	Conducted Power(dBm)	MPRAllowed Per 3GPP(dB)	MPR (dB)
Low	825.5	20415	3	QPSK	1	0	22.61	0	0
	825.5	20415	3	QPSK	1	7	22.69	0	0
	825.5	20415	3	QPSK	1	14	22.69	0	0
	825.5	20415	3	QPSK	8	0	21.49	0-1	1
	825.5	20415	3	QPSK	8	4	21.47	0-1	1
	825.5	20415	3	QPSK	8	7	21.44	0-1	1
	825.5	20415	3	QPSK	15	0	21.49	0-1	1
	825.5	20415	3	16QAM	1	0	22.66	0-1	1
	825.5	20415	3	16QAM	1	7	22.00	0-1	1
	825.5	20415	3	16QAM	1	14	22.04	0-1	1
	825.5	20415	3	16QAM	8	0	20.90	0-2	2
	825.5	20415	3	16QAM	8	4	20.85	0-2	2
	825.5	20415	3	16QAM	8	7	20.77	0-2	2
	825.5	20415	3	16QAM	15	0	20.90	0-2	2
Mid	836.5	20525	3	QPSK	1	0	22.94	0	0
	836.5	20525	3	QPSK	1	7	22.77	0	0
	836.5	20525	3	QPSK	1	14	22.86	0	0
	836.5	20525	3	QPSK	8	0	21.74	0-1	1
	836.5	20525	3	QPSK	8	4	21.65	0-1	1
	836.5	20525	3	QPSK	8	7	21.69	0-1	1
	836.5	20525	3	QPSK	15	0	21.68	0-1	1
	836.5	20525	3	16QAM	1	0	22.38	0-1	1
	836.5	20525	3	16QAM	1	7	22.22	0-1	1
	836.5	20525	3	16QAM	1	14	22.33	0-1	1
	836.5	20525	3	16QAM	8	0	20.93	0-2	2
	836.5	20525	3	16QAM	8	4	20.83	0-2	2
	836.5	20525	3	16QAM	8	7	21.05	0-2	2
	836.5	20525	3	16QAM	15	0	20.86	0-2	2
High	847.5	20635	3	QPSK	1	0	23.09	0	0
	847.5	20635	3	QPSK	1	7	23.12	0	0
	847.5	20635	3	QPSK	1	14	23.17	0	0
	847.5	20635	3	QPSK	8	0	22.22	0-1	1
	847.5	20635	3	QPSK	8	4	22.24	0-1	1
	847.5	20635	3	QPSK	8	7	22.36	0-1	1
	847.5	20635	3	QPSK	15	0	22.25	0-1	1
	847.5	20635	3	16QAM	1	0	22.64	0-1	1
	847.5	20635	3	16QAM	1	7	22.74	0-1	1
	847.5	20635	3	16QAM	1	14	22.23	0-1	1
	847.5	20635	3	16QAM	8	0	21.18	0-2	2
	847.5	20635	3	16QAM	8	4	21.46	0-2	2
	847.5	20635	3	16QAM	8	7	21.47	0-2	2
	847.5	20635	3	16QAM	15	0	21.55	0-2	2

Table 10.3.5 The power was measured by CMW500

Mode	Freq. (MHz)	Channel	LTE Band 5 Conducted Power- 1.4 MHz Bandwidth						
			Bandwidth (MHz)	Modulation	RB Size	RB Offset	Conducted Power(dBm)	MPRAllowed Per 3GPP(dB)	MPR (dB)
Low	824.7	20407	1.4	QPSK	1	0	22.58	0	0
	824.7	20407	1.4	QPSK	1	2	22.75	0	0
	824.7	20407	1.4	QPSK	1	5	22.61	0	0
	824.7	20407	1.4	QPSK	3	0	22.56	0-1	1
	824.7	20407	1.4	QPSK	3	2	22.61	0-1	1
	824.7	20407	1.4	QPSK	3	3	22.61	0-1	1
	824.7	20407	1.4	QPSK	6	0	21.50	0-1	1
	824.7	20407	1.4	16QAM	1	0	22.14	0-1	1
	824.7	20407	1.4	16QAM	1	2	22.13	0-1	1
	824.7	20407	1.4	16QAM	1	5	22.13	0-1	1
	824.7	20407	1.4	16QAM	3	0	21.92	0-2	2
	824.7	20407	1.4	16QAM	3	2	21.74	0-2	2
	824.7	20407	1.4	16QAM	3	3	22.05	0-2	2
	824.7	20407	1.4	16QAM	6	0	20.68	0-2	2
Mid	836.5	20525	1.4	QPSK	1	0	22.71	0	0
	836.5	20525	1.4	QPSK	1	2	22.82	0	0
	836.5	20525	1.4	QPSK	1	5	22.70	0	0
	836.5	20525	1.4	QPSK	3	0	22.77	0-1	1
	836.5	20525	1.4	QPSK	3	2	22.67	0-1	1
	836.5	20525	1.4	QPSK	3	3	22.74	0-1	1
	836.5	20525	1.4	QPSK	6	0	21.63	0-1	1
	836.5	20525	1.4	16QAM	1	0	22.22	0-1	1
	836.5	20525	1.4	16QAM	1	2	22.19	0-1	1
	836.5	20525	1.4	16QAM	1	5	22.14	0-1	1
	836.5	20525	1.4	16QAM	3	0	21.66	0-2	2
	836.5	20525	1.4	16QAM	3	2	21.66	0-2	2
	836.5	20525	1.4	16QAM	3	3	21.70	0-2	2
	836.5	20525	1.4	16QAM	6	0	20.82	0-2	2
High	848.3	20643	1.4	QPSK	1	0	23.04	0	0
	848.3	20643	1.4	QPSK	1	2	23.35	0	0
	848.3	20643	1.4	QPSK	1	5	23.38	0	0
	848.3	20643	1.4	QPSK	3	0	23.36	0-1	1
	848.3	20643	1.4	QPSK	3	2	23.23	0-1	1
	848.3	20643	1.4	QPSK	3	3	23.23	0-1	1
	848.3	20643	1.4	QPSK	6	0	22.19	0-1	1
	848.3	20643	1.4	16QAM	1	0	22.63	0-1	1
	848.3	20643	1.4	16QAM	1	2	22.24	0-1	1
	848.3	20643	1.4	16QAM	1	5	22.13	0-1	1
	848.3	20643	1.4	16QAM	3	0	22.34	0-2	2
	848.3	20643	1.4	16QAM	3	2	22.25	0-2	2
	848.3	20643	1.4	16QAM	3	3	22.15	0-2	2
	848.3	20643	1.4	16QAM	6	0	20.93	0-2	2

Table 10.3.6The power was measured by CMW500

3) LTE Band 4

Mode	Freq. (MHz)	Channel	LTE Band 4 (AWS) Conducted Power– 20 MHz Bandwidth						
			Bandwidth (MHz)	Modulation	RB Size	RB Offset	Conducted Power(dBm)	MPRAllowed Per 3GPP(dB)	MPR (dB)
Low	1720	20050	20	QPSK	1	0	22.92	0	0
	1720	20050	20	QPSK	1	50	23.00	0	0
	1720	20050	20	QPSK	1	99	22.58	0	0
	1720	20050	20	QPSK	50	0	21.92	0-1	1
	1720	20050	20	QPSK	50	25	21.87	0-1	1
	1720	20050	20	QPSK	50	50	21.73	0-1	1
	1720	20050	20	QPSK	100	0	21.89	0-1	1
	1720	20050	20	16QAM	1	0	22.42	0-1	1
	1720	20050	20	16QAM	1	50	22.35	0-1	1
	1720	20050	20	16QAM	1	99	22.11	0-1	1
	1720	20050	20	16QAM	50	0	20.98	0-2	2
	1720	20050	20	16QAM	50	25	20.94	0-2	2
	1720	20050	20	16QAM	50	50	20.69	0-2	2
	1720	20050	20	16QAM	100	0	20.85	0-2	2
High	1745	20300	20	QPSK	1	0	23.00	0	0
	1745	20300	20	QPSK	1	50	22.83	0	0
	1745	20300	20	QPSK	1	99	22.72	0	0
	1745	20300	20	QPSK	50	0	21.52	0-1	1
	1745	20300	20	QPSK	50	25	21.51	0-1	1
	1745	20300	20	QPSK	50	50	21.31	0-1	1
	1745	20300	20	QPSK	100	0	21.44	0-1	1
	1745	20300	20	16QAM	1	0	22.17	0-1	1
	1745	20300	20	16QAM	1	50	22.26	0-1	1
	1745	20300	20	16QAM	1	99	21.83	0-1	1
	1745	20300	20	16QAM	50	0	20.55	0-2	2
	1745	20300	20	16QAM	50	25	20.47	0-2	2
	1745	20300	20	16QAM	50	50	20.30	0-2	2
	1745	20300	20	16QAM	100	0	20.40	0-2	2

Table 10.3.7 The power was measured by CMW500

Mode	Freq. (MHz)	Channel	LTE Band 4 (AWS) Conducted Power- 15 MHz Bandwidth						
			Bandwidth (MHz)	Modulation	RB Size	RB Offset	Conducted Power(dBm)	MPRAllowed Per 3GPP(dB)	MPR (dB)
Low	1717.5	20025	15	QPSK	1	0	22.90	0	0
	1717.5	20025	15	QPSK	1	36	22.79	0	0
	1717.5	20025	15	QPSK	1	74	23.05	0	0
	1717.5	20025	15	QPSK	36	0	21.81	0-1	1
	1717.5	20025	15	QPSK	36	18	21.62	0-1	1
	1717.5	20025	15	QPSK	36	37	21.57	0-1	1
	1717.5	20025	15	QPSK	75	0	21.68	0-1	1
	1717.5	20025	15	16QAM	1	0	22.31	0-1	1
	1717.5	20025	15	16QAM	1	36	22.14	0-1	1
	1717.5	20025	15	16QAM	1	74	22.09	0-1	1
	1717.5	20025	15	16QAM	36	0	20.78	0-2	2
	1717.5	20025	15	16QAM	36	18	20.68	0-2	2
	1717.5	20025	15	16QAM	36	37	20.66	0-2	2
	1717.5	20025	15	16QAM	75	0	20.73	0-2	2
Mid	1732.5	20175	15	QPSK	1	0	23.10	0	0
	1732.5	20175	15	QPSK	1	36	22.74	0	0
	1732.5	20175	15	QPSK	1	74	22.66	0	0
	1732.5	20175	15	QPSK	36	0	21.67	0-1	1
	1732.5	20175	15	QPSK	36	18	21.56	0-1	1
	1732.5	20175	15	QPSK	36	37	21.52	0-1	1
	1732.5	20175	15	QPSK	75	0	21.57	0-1	1
	1732.5	20175	15	16QAM	1	0	22.45	0-1	1
	1732.5	20175	15	16QAM	1	36	21.99	0-1	1
	1732.5	20175	15	16QAM	1	74	22.03	0-1	1
	1732.5	20175	15	16QAM	36	0	20.73	0-2	2
	1732.5	20175	15	16QAM	36	18	20.64	0-2	2
	1732.5	20175	15	16QAM	36	37	20.59	0-2	2
	1732.5	20175	15	16QAM	75	0	20.51	0-2	2
High	1747.5	20325	15	QPSK	1	0	22.86	0	0
	1747.5	20325	15	QPSK	1	36	22.70	0	0
	1747.5	20325	15	QPSK	1	74	22.46	0	0
	1747.5	20325	15	QPSK	36	0	21.64	0-1	1
	1747.5	20325	15	QPSK	36	18	21.60	0-1	1
	1747.5	20325	15	QPSK	36	37	21.51	0-1	1
	1747.5	20325	15	QPSK	75	0	21.49	0-1	1
	1747.5	20325	15	16QAM	1	0	22.32	0-1	1
	1747.5	20325	15	16QAM	1	36	22.07	0-1	1
	1747.5	20325	15	16QAM	1	74	21.98	0-1	1
	1747.5	20325	15	16QAM	36	0	20.52	0-2	2
	1747.5	20325	15	16QAM	36	18	20.46	0-2	2
	1747.5	20325	15	16QAM	36	37	20.30	0-2	2
	1747.5	20325	15	16QAM	75	0	20.44	0-2	2

Table 10.3.8The power was measured by CMW500

Mode	Freq. (MHz)	Channel	LTE Band 4 (AWS) Conducted Power- 10 MHz Bandwidth						
			Bandwidth (MHz)	Modulation	RB Size	RB Offset	Conducted Power(dBm)	MPRAllowed Per 3GPP(dB)	MPR (dB)
Low	1715	20000	10	QPSK	1	0	23.01	0	0
	1715	20000	10	QPSK	1	25	22.76	0	0
	1715	20000	10	QPSK	1	49	23.00	0	0
	1715	20000	10	QPSK	25	0	21.67	0-1	1
	1715	20000	10	QPSK	25	12	21.65	0-1	1
	1715	20000	10	QPSK	25	25	21.56	0-1	1
	1715	20000	10	QPSK	50	0	21.67	0-1	1
	1715	20000	10	16QAM	1	0	22.24	0-1	1
	1715	20000	10	16QAM	1	25	22.18	0-1	1
	1715	20000	10	16QAM	1	49	22.20	0-1	1
	1715	20000	10	16QAM	25	0	20.95	0-2	2
	1715	20000	10	16QAM	25	12	20.92	0-2	2
	1715	20000	10	16QAM	25	25	20.98	0-2	2
	1715	20000	10	16QAM	50	0	20.77	0-2	2
Mid	1732.5	20175	10	QPSK	1	0	23.05	0	0
	1732.5	20175	10	QPSK	1	25	22.82	0	0
	1732.5	20175	10	QPSK	1	49	22.84	0	0
	1732.5	20175	10	QPSK	25	0	21.56	0-1	1
	1732.5	20175	10	QPSK	25	12	21.51	0-1	1
	1732.5	20175	10	QPSK	25	25	21.47	0-1	1
	1732.5	20175	10	QPSK	50	0	21.57	0-1	1
	1732.5	20175	10	16QAM	1	0	22.24	0-1	1
	1732.5	20175	10	16QAM	1	25	22.04	0-1	1
	1732.5	20175	10	16QAM	1	49	21.94	0-1	1
	1732.5	20175	10	16QAM	25	0	20.77	0-2	2
	1732.5	20175	10	16QAM	25	12	20.68	0-2	2
	1732.5	20175	10	16QAM	25	25	20.61	0-2	2
	1732.5	20175	10	16QAM	50	0	20.61	0-2	2
High	1750	20350	10	QPSK	1	0	22.98	0	0
	1750	20350	10	QPSK	1	25	22.71	0	0
	1750	20350	10	QPSK	1	49	22.76	0	0
	1750	20350	10	QPSK	25	0	21.64	0-1	1
	1750	20350	10	QPSK	25	12	21.58	0-1	1
	1750	20350	10	QPSK	25	25	21.47	0-1	1
	1750	20350	10	QPSK	50	0	21.51	0-1	1
	1750	20350	10	16QAM	1	0	22.22	0-1	1
	1750	20350	10	16QAM	1	25	22.22	0-1	1
	1750	20350	10	16QAM	1	49	22.06	0-1	1
	1750	20350	10	16QAM	25	0	20.93	0-2	2
	1750	20350	10	16QAM	25	12	20.59	0-2	2
	1750	20350	10	16QAM	25	25	20.76	0-2	2
	1750	20350	10	16QAM	50	0	20.59	0-2	2

Table 10.3.9 The power was measured by CMW500

Mode	Freq. (MHz)	Channel	LTE Band 4 (AWS) Conducted Power– 5 MHz Bandwidth						
			Bandwidth (MHz)	Modulation	RB Size	RB Offset	Conducted Power(dBm)	MPRAllowed Per 3GPP(dB)	MPR (dB)
Low	1712.5	19975	5	QPSK	1	0	22.81	0	0
	1712.5	19975	5	QPSK	1	12	22.85	0	0
	1712.5	19975	5	QPSK	1	24	22.88	0	0
	1712.5	19975	5	QPSK	12	0	21.67	0-1	1
	1712.5	19975	5	QPSK	12	6	21.59	0-1	1
	1712.5	19975	5	QPSK	12	13	21.62	0-1	1
	1712.5	19975	5	QPSK	25	0	21.63	0-1	1
	1712.5	19975	5	16QAM	1	0	22.46	0-1	1
	1712.5	19975	5	16QAM	1	12	22.07	0-1	1
	1712.5	19975	5	16QAM	1	24	22.08	0-1	1
	1712.5	19975	5	16QAM	12	0	20.75	0-2	2
	1712.5	19975	5	16QAM	12	6	20.76	0-2	2
	1712.5	19975	5	16QAM	12	13	20.70	0-2	2
	1712.5	19975	5	16QAM	25	0	20.93	0-2	2
Mid	1732.5	20175	5	QPSK	1	0	22.82	0	0
	1732.5	20175	5	QPSK	1	12	22.64	0	0
	1732.5	20175	5	QPSK	1	24	22.62	0	0
	1732.5	20175	5	QPSK	12	0	21.60	0-1	1
	1732.5	20175	5	QPSK	12	6	21.53	0-1	1
	1732.5	20175	5	QPSK	12	13	21.49	0-1	1
	1732.5	20175	5	QPSK	25	0	21.59	0-1	1
	1732.5	20175	5	16QAM	1	0	22.02	0-1	1
	1732.5	20175	5	16QAM	1	12	22.07	0-1	1
	1732.5	20175	5	16QAM	1	24	22.05	0-1	1
	1732.5	20175	5	16QAM	12	0	20.58	0-2	2
	1732.5	20175	5	16QAM	12	6	20.48	0-2	2
	1732.5	20175	5	16QAM	12	13	20.55	0-2	2
	1732.5	20175	5	16QAM	25	0	20.75	0-2	2
High	1752.5	20375	5	QPSK	1	0	22.92	0	0
	1752.5	20375	5	QPSK	1	12	22.67	0	0
	1752.5	20375	5	QPSK	1	24	22.71	0	0
	1752.5	20375	5	QPSK	12	0	21.55	0-1	1
	1752.5	20375	5	QPSK	12	6	21.55	0-1	1
	1752.5	20375	5	QPSK	12	13	21.52	0-1	1
	1752.5	20375	5	QPSK	25	0	21.53	0-1	1
	1752.5	20375	5	16QAM	1	0	22.14	0-1	1
	1752.5	20375	5	16QAM	1	12	21.00	0-1	1
	1752.5	20375	5	16QAM	1	24	21.95	0-1	1
	1752.5	20375	5	16QAM	12	0	20.51	0-2	2
	1752.5	20375	5	16QAM	12	6	20.55	0-2	2
	1752.5	20375	5	16QAM	12	13	20.51	0-2	2
	1752.5	20375	5	16QAM	25	0	20.53	0-2	2

Table 10.3.10The power was measured by CMW500

Mode	Freq. (MHz)	Channel	LTE Band 4 (AWS) Conducted Power– 3 MHz Bandwidth						
			Bandwidth (MHz)	Modulation	RB Size	RB Offset	Conducted Power(dBm)	MPRAllowed Per 3GPP(dB)	MPR (dB)
Low	1711.5	19965	3	QPSK	1	0	22.37	0	0
	1711.5	19965	3	QPSK	1	7	22.86	0	0
	1711.5	19965	3	QPSK	1	14	22.96	0	0
	1711.5	19965	3	QPSK	8	0	21.66	0-1	1
	1711.5	19965	3	QPSK	8	4	21.66	0-1	1
	1711.5	19965	3	QPSK	8	7	21.65	0-1	1
	1711.5	19965	3	QPSK	15	0	21.67	0-1	1
	1711.5	19965	3	16QAM	1	0	22.18	0-1	1
	1711.5	19965	3	16QAM	1	7	22.10	0-1	1
	1711.5	19965	3	16QAM	1	14	22.17	0-1	1
	1711.5	19965	3	16QAM	8	0	20.88	0-2	2
	1711.5	19965	3	16QAM	8	4	20.98	0-2	2
	1711.5	19965	3	16QAM	8	7	20.85	0-2	2
1711.5	19965	3	16QAM	15	0	20.86	0-2	2	
Mid	1732.5	20175	3	QPSK	1	0	22.75	0	0
	1732.5	20175	3	QPSK	1	7	22.66	0	0
	1732.5	20175	3	QPSK	1	14	22.58	0	0
	1732.5	20175	3	QPSK	8	0	21.61	0-1	1
	1732.5	20175	3	QPSK	8	4	21.61	0-1	1
	1732.5	20175	3	QPSK	8	7	21.51	0-1	1
	1732.5	20175	3	QPSK	15	0	21.52	0-1	1
	1732.5	20175	3	16QAM	1	0	22.15	0-1	1
	1732.5	20175	3	16QAM	1	7	21.92	0-1	1
	1732.5	20175	3	16QAM	1	14	22.08	0-1	1
	1732.5	20175	3	16QAM	8	0	20.78	0-2	2
	1732.5	20175	3	16QAM	8	4	20.44	0-2	2
	1732.5	20175	3	16QAM	8	7	20.74	0-2	2
1732.5	20175	3	16QAM	15	0	20.76	0-2	2	
High	1753.5	20385	3	QPSK	1	0	22.70	0	0
	1753.5	20385	3	QPSK	1	7	22.59	0	0
	1753.5	20385	3	QPSK	1	14	22.66	0	0
	1753.5	20385	3	QPSK	8	0	21.63	0-1	1
	1753.5	20385	3	QPSK	8	4	21.59	0-1	1
	1753.5	20385	3	QPSK	8	7	21.54	0-1	1
	1753.5	20385	3	QPSK	15	0	21.47	0-1	1
	1753.5	20385	3	16QAM	1	0	22.12	0-1	1
	1753.5	20385	3	16QAM	1	7	22.04	0-1	1
	1753.5	20385	3	16QAM	1	14	22.06	0-1	1
	1753.5	20385	3	16QAM	8	0	20.78	0-2	2
	1753.5	20385	3	16QAM	8	4	20.74	0-2	2
	1753.5	20385	3	16QAM	8	7	20.69	0-2	2
1753.5	20385	3	16QAM	15	0	20.73	0-2	2	

Table 10.3.11The power was measured by CMW500

Mode	Freq. (MHz)	Channel	LTE Band 4 (AWS) Conducted Power- 1.4 MHz Bandwidth						
			Bandwidth (MHz)	Modulation	RB Size	RB Offset	Conducted Power(dBm)	MPRAllowed Per 3GPP(dB)	MPR (dB)
Low	1710.7	19957	1.4	QPSK	1	0	22.47	0	0
	1710.7	19957	1.4	QPSK	1	2	22.54	0	0
	1710.7	19957	1.4	QPSK	1	5	22.41	0	0
	1710.7	19957	1.4	QPSK	3	0	22.48	0-1	1
	1710.7	19957	1.4	QPSK	3	2	22.52	0-1	1
	1710.7	19957	1.4	QPSK	3	3	22.54	0-1	1
	1710.7	19957	1.4	QPSK	6	0	21.56	0-1	1
	1710.7	19957	1.4	16QAM	1	0	22.11	0-1	1
	1710.7	19957	1.4	16QAM	1	2	22.13	0-1	1
	1710.7	19957	1.4	16QAM	1	5	22.13	0-1	1
	1710.7	19957	1.4	16QAM	3	0	21.69	0-2	2
	1710.7	19957	1.4	16QAM	3	2	21.75	0-2	2
	1710.7	19957	1.4	16QAM	3	3	21.69	0-2	2
	1710.7	19957	1.4	16QAM	6	0	20.75	0-2	2
Mid	1732.5	20175	1.4	QPSK	1	0	22.68	0	0
	1732.5	20175	1.4	QPSK	1	2	22.71	0	0
	1732.5	20175	1.4	QPSK	1	5	22.66	0	0
	1732.5	20175	1.4	QPSK	3	0	22.60	0-1	1
	1732.5	20175	1.4	QPSK	3	2	22.54	0-1	1
	1732.5	20175	1.4	QPSK	3	3	22.48	0-1	1
	1732.5	20175	1.4	QPSK	6	0	21.48	0-1	1
	1732.5	20175	1.4	16QAM	1	0	22.08	0-1	1
	1732.5	20175	1.4	16QAM	1	2	22.10	0-1	1
	1732.5	20175	1.4	16QAM	1	5	22.08	0-1	1
	1732.5	20175	1.4	16QAM	3	0	21.69	0-2	2
	1732.5	20175	1.4	16QAM	3	2	21.62	0-2	2
	1732.5	20175	1.4	16QAM	3	3	21.57	0-2	2
	1732.5	20175	1.4	16QAM	6	0	20.53	0-2	2
High	1754.3	20393	1.4	QPSK	1	0	22.63	0	0
	1754.3	20393	1.4	QPSK	1	2	22.81	0	0
	1754.3	20393	1.4	QPSK	1	5	22.64	0	0
	1754.3	20393	1.4	QPSK	3	0	22.55	0-1	1
	1754.3	20393	1.4	QPSK	3	2	22.55	0-1	1
	1754.3	20393	1.4	QPSK	3	3	22.48	0-1	1
	1754.3	20393	1.4	QPSK	6	0	21.51	0-1	1
	1754.3	20393	1.4	16QAM	1	0	21.87	0-1	1
	1754.3	20393	1.4	16QAM	1	2	22.04	0-1	1
	1754.3	20393	1.4	16QAM	1	5	22.10	0-1	1
	1754.3	20393	1.4	16QAM	3	0	21.67	0-2	2
	1754.3	20393	1.4	16QAM	3	2	21.39	0-2	2
	1754.3	20393	1.4	16QAM	3	3	21.64	0-2	2
	1754.3	20393	1.4	16QAM	6	0	20.65	0-2	2

Table 10.3.12The power was measured by CMW500

4) LTE Band 2

Mode	Freq. (MHz)	Channel	LTE Band 2 (PCS) Conducted Power- 20 MHz Bandwidth						
			Bandwidth (MHz)	Modulation	RB Size	RB Offset	Conducted Power(dBm)	MPRAllowed Per 3GPP(dB)	MPR (dB)
Low	1860	18700	20	QPSK	1	0	23.10	0	0
	1860	18700	20	QPSK	1	50	22.95	0	0
	1860	18700	20	QPSK	1	99	22.89	0	0
	1860	18700	20	QPSK	50	0	21.87	0-1	1
	1860	18700	20	QPSK	50	25	21.85	0-1	1
	1860	18700	20	QPSK	50	50	21.86	0-1	1
	1860	18700	20	QPSK	100	0	21.79	0-1	1
	1860	18700	20	16QAM	1	0	22.49	0-1	1
	1860	18700	20	16QAM	1	50	22.71	0-1	1
	1860	18700	20	16QAM	1	99	22.32	0-1	1
	1860	18700	20	16QAM	50	0	20.86	0-2	2
	1860	18700	20	16QAM	50	25	20.86	0-2	2
	1860	18700	20	16QAM	50	50	20.80	0-2	2
	1860	18700	20	16QAM	100	0	20.97	0-2	2
Mid	1880	18900	20	QPSK	1	0	23.05	0	0
	1880	18900	20	QPSK	1	50	23.02	0	0
	1880	18900	20	QPSK	1	99	22.84	0	0
	1880	18900	20	QPSK	50	0	22.00	0-1	1
	1880	18900	20	QPSK	50	25	21.91	0-1	1
	1880	18900	20	QPSK	50	50	21.81	0-1	1
	1880	18900	20	QPSK	100	0	21.90	0-1	1
	1880	18900	20	16QAM	1	0	22.50	0-1	1
	1880	18900	20	16QAM	1	50	22.49	0-1	1
	1880	18900	20	16QAM	1	99	22.36	0-1	1
	1880	18900	20	16QAM	50	0	21.15	0-2	2
	1880	18900	20	16QAM	50	25	20.90	0-2	2
	1880	18900	20	16QAM	50	50	20.96	0-2	2
	1880	18900	20	16QAM	100	0	20.96	0-2	2
High	1900	19100	20	QPSK	1	0	22.70	0	0
	1900	19100	20	QPSK	1	50	22.66	0	0
	1900	19100	20	QPSK	1	99	22.63	0	0
	1900	19100	20	QPSK	50	0	21.63	0-1	1
	1900	19100	20	QPSK	50	25	21.58	0-1	1
	1900	19100	20	QPSK	50	50	21.43	0-1	1
	1900	19100	20	QPSK	100	0	21.61	0-1	1
	1900	19100	20	16QAM	1	0	22.32	0-1	1
	1900	19100	20	16QAM	1	50	22.13	0-1	1
	1900	19100	20	16QAM	1	99	21.90	0-1	1
	1900	19100	20	16QAM	50	0	20.74	0-2	2
	1900	19100	20	16QAM	50	25	20.64	0-2	2
	1900	19100	20	16QAM	50	50	20.59	0-2	2
	1900	19100	20	16QAM	100	0	20.73	0-2	2

Table 10.3.13The power was measured by CMW500

Mode	Freq. (MHz)	Channel	LTE Band 2 (PCS) Conducted Power– 15 MHz Bandwidth						
			Bandwidth (MHz)	Modulation	RB Size	RB Offset	Conducted Power(dBm)	MPRAllowed Per 3GPP(dB)	MPR (dB)
Low	1857.5	18675	15	QPSK	1	0	22.97	0	0
	1857.5	18675	15	QPSK	1	36	22.45	0	0
	1857.5	18675	15	QPSK	1	74	22.54	0	0
	1857.5	18675	15	QPSK	36	0	21.69	0-1	1
	1857.5	18675	15	QPSK	36	18	21.73	0-1	1
	1857.5	18675	15	QPSK	36	37	21.75	0-1	1
	1857.5	18675	15	QPSK	75	0	21.72	0-1	1
	1857.5	18675	15	16QAM	1	0	21.95	0-1	1
	1857.5	18675	15	16QAM	1	36	21.86	0-1	1
	1857.5	18675	15	16QAM	1	74	22.11	0-1	1
	1857.5	18675	15	16QAM	36	0	20.87	0-2	2
	1857.5	18675	15	16QAM	36	18	20.78	0-2	2
	1857.5	18675	15	16QAM	36	37	20.83	0-2	2
	1857.5	18675	15	16QAM	75	0	20.80	0-2	2
Mid	1880	18900	15	QPSK	1	0	22.82	0	0
	1880	18900	15	QPSK	1	36	22.73	0	0
	1880	18900	15	QPSK	1	74	22.64	0	0
	1880	18900	15	QPSK	36	0	21.84	0-1	1
	1880	18900	15	QPSK	36	18	21.73	0-1	1
	1880	18900	15	QPSK	36	37	21.63	0-1	1
	1880	18900	15	QPSK	75	0	21.78	0-1	1
	1880	18900	15	16QAM	1	0	22.42	0-1	1
	1880	18900	15	16QAM	1	36	22.26	0-1	1
	1880	18900	15	16QAM	1	74	22.19	0-1	1
	1880	18900	15	16QAM	36	0	20.91	0-2	2
	1880	18900	15	16QAM	36	18	20.96	0-2	2
	1880	18900	15	16QAM	36	37	20.75	0-2	2
	1880	18900	15	16QAM	75	0	20.93	0-2	2
High	1902.5	19125	15	QPSK	1	0	22.92	0	0
	1902.5	19125	15	QPSK	1	36	22.79	0	0
	1902.5	19125	15	QPSK	1	74	22.71	0	0
	1902.5	19125	15	QPSK	36	0	21.81	0-1	1
	1902.5	19125	15	QPSK	36	18	21.70	0-1	1
	1902.5	19125	15	QPSK	36	37	21.66	0-1	1
	1902.5	19125	15	QPSK	75	0	21.61	0-1	1
	1902.5	19125	15	16QAM	1	0	22.39	0-1	1
	1902.5	19125	15	16QAM	1	36	22.22	0-1	1
	1902.5	19125	15	16QAM	1	74	22.14	0-1	1
	1902.5	19125	15	16QAM	36	0	20.81	0-2	2
	1902.5	19125	15	16QAM	36	18	20.72	0-2	2
	1902.5	19125	15	16QAM	36	37	20.70	0-2	2
	1902.5	19125	15	16QAM	75	0	20.70	0-2	2

Table 10.3.14 The power was measured by CMW500

Mode	Freq. (MHz)	Channel	LTE Band 2 (PCS) Conducted Power– 10 MHz Bandwidth						
			Bandwidth (MHz)	Modulation	RB Size	RB Offset	Conducted Power(dBm)	MPRAllowed Per 3GPP(dB)	MPR (dB)
Low	1855	18650	10	QPSK	1	0	22.57	0	0
	1855	18650	10	QPSK	1	25	22.68	0	0
	1855	18650	10	QPSK	1	49	22.71	0	0
	1855	18650	10	QPSK	25	0	21.66	0-1	1
	1855	18650	10	QPSK	25	12	21.64	0-1	1
	1855	18650	10	QPSK	25	25	21.72	0-1	1
	1855	18650	10	QPSK	50	0	21.69	0-1	1
	1855	18650	10	16QAM	1	0	22.23	0-1	1
	1855	18650	10	16QAM	1	25	22.17	0-1	1
	1855	18650	10	16QAM	1	49	22.18	0-1	1
	1855	18650	10	16QAM	25	0	20.90	0-2	2
	1855	18650	10	16QAM	25	12	20.90	0-2	2
	1855	18650	10	16QAM	25	25	20.98	0-2	2
	1855	18650	10	16QAM	50	0	20.75	0-2	2
Mid	1880	18900	10	QPSK	1	0	22.95	0	0
	1880	18900	10	QPSK	1	25	22.82	0	0
	1880	18900	10	QPSK	1	49	22.73	0	0
	1880	18900	10	QPSK	25	0	21.76	0-1	1
	1880	18900	10	QPSK	25	12	21.80	0-1	1
	1880	18900	10	QPSK	25	25	21.72	0-1	1
	1880	18900	10	QPSK	50	0	21.82	0-1	1
	1880	18900	10	16QAM	1	0	22.33	0-1	1
	1880	18900	10	16QAM	1	25	22.34	0-1	1
	1880	18900	10	16QAM	1	49	22.21	0-1	1
	1880	18900	10	16QAM	25	0	20.96	0-2	2
	1880	18900	10	16QAM	25	12	20.88	0-2	2
	1880	18900	10	16QAM	25	25	21.09	0-2	2
	1880	18900	10	16QAM	50	0	20.88	0-2	2
High	1905	19150	10	QPSK	1	0	22.93	0	0
	1905	19150	10	QPSK	1	25	22.56	0	0
	1905	19150	10	QPSK	1	49	22.58	0	0
	1905	19150	10	QPSK	25	0	21.75	0-1	1
	1905	19150	10	QPSK	25	12	21.58	0-1	1
	1905	19150	10	QPSK	25	25	21.58	0-1	1
	1905	19150	10	QPSK	50	0	21.60	0-1	1
	1905	19150	10	16QAM	1	0	22.43	0-1	1
	1905	19150	10	16QAM	1	25	22.33	0-1	1
	1905	19150	10	16QAM	1	49	22.17	0-1	1
	1905	19150	10	16QAM	25	0	20.89	0-2	2
	1905	19150	10	16QAM	25	12	20.71	0-2	2
	1905	19150	10	16QAM	25	25	20.72	0-2	2
	1905	19150	10	16QAM	50	0	20.70	0-2	2

Table 10.3.15The power was measured by CMW500

Mode	Freq. (MHz)	Channel	LTE Band 2 (PCS) Conducted Power– 5 MHz Bandwidth						
			Bandwidth (MHz)	Modulation	RB Size	RB Offset	Conducted Power(dBm)	MPRAllowed Per 3GPP(dB)	MPR (dB)
Low	1852.5	18625	5	QPSK	1	0	22.59	0	0
	1852.5	18625	5	QPSK	1	12	22.93	0	0
	1852.5	18625	5	QPSK	1	24	22.81	0	0
	1852.5	18625	5	QPSK	12	0	21.73	0-1	1
	1852.5	18625	5	QPSK	12	6	21.75	0-1	1
	1852.5	18625	5	QPSK	12	13	21.72	0-1	1
	1852.5	18625	5	QPSK	25	0	21.69	0-1	1
	1852.5	18625	5	16QAM	1	0	22.26	0-1	1
	1852.5	18625	5	16QAM	1	12	22.21	0-1	1
	1852.5	18625	5	16QAM	1	24	22.27	0-1	1
	1852.5	18625	5	16QAM	12	0	20.86	0-2	2
	1852.5	18625	5	16QAM	12	6	20.87	0-2	2
	1852.5	18625	5	16QAM	12	13	20.81	0-2	2
	1852.5	18625	5	16QAM	25	0	20.83	0-2	2
Mid	1880	18900	5	QPSK	1	0	22.82	0	0
	1880	18900	5	QPSK	1	12	22.77	0	0
	1880	18900	5	QPSK	1	24	22.85	0	0
	1880	18900	5	QPSK	12	0	21.85	0-1	1
	1880	18900	5	QPSK	12	6	21.84	0-1	1
	1880	18900	5	QPSK	12	13	21.86	0-1	1
	1880	18900	5	QPSK	25	0	21.88	0-1	1
	1880	18900	5	16QAM	1	0	22.46	0-1	1
	1880	18900	5	16QAM	1	12	22.43	0-1	1
	1880	18900	5	16QAM	1	24	22.32	0-1	1
	1880	18900	5	16QAM	12	0	20.99	0-2	2
	1880	18900	5	16QAM	12	6	20.98	0-2	2
	1880	18900	5	16QAM	12	13	20.91	0-2	2
	1880	18900	5	16QAM	25	0	21.02	0-2	2
High	1907.5	19175	5	QPSK	1	0	22.91	0	0
	1907.5	19175	5	QPSK	1	12	22.72	0	0
	1907.5	19175	5	QPSK	1	24	22.77	0	0
	1907.5	19175	5	QPSK	12	0	21.73	0-1	1
	1907.5	19175	5	QPSK	12	6	21.68	0-1	1
	1907.5	19175	5	QPSK	12	13	21.68	0-1	1
	1907.5	19175	5	QPSK	25	0	21.73	0-1	1
	1907.5	19175	5	16QAM	1	0	22.36	0-1	1
	1907.5	19175	5	16QAM	1	12	22.21	0-1	1
	1907.5	19175	5	16QAM	1	24	22.18	0-1	1
	1907.5	19175	5	16QAM	12	0	20.80	0-2	2
	1907.5	19175	5	16QAM	12	6	20.78	0-2	2
	1907.5	19175	5	16QAM	12	13	20.75	0-2	2
	1907.5	19175	5	16QAM	25	0	20.91	0-2	2

Table 10.3.16The power was measured by CMW500

Mode	Freq. (MHz)	Channel	LTE Band 2 (PCS) Conducted Power– 3 MHz Bandwidth						
			Bandwidth (MHz)	Modulation	RB Size	RB Offset	Conducted Power(dBm)	MPRAllowed Per 3GPP(dB)	MPR (dB)
Low	1851.5	18615	3	QPSK	1	0	22.76	0	0
	1851.5	18615	3	QPSK	1	7	22.77	0	0
	1851.5	18615	3	QPSK	1	14	22.83	0	0
	1851.5	18615	3	QPSK	8	0	21.51	0-1	1
	1851.5	18615	3	QPSK	8	4	21.55	0-1	1
	1851.5	18615	3	QPSK	8	7	21.58	0-1	1
	1851.5	18615	3	QPSK	15	0	21.51	0-1	1
	1851.5	18615	3	16QAM	1	0	22.30	0-1	1
	1851.5	18615	3	16QAM	1	7	22.18	0-1	1
	1851.5	18615	3	16QAM	1	14	22.07	0-1	1
	1851.5	18615	3	16QAM	8	0	21.11	0-2	2
	1851.5	18615	3	16QAM	8	4	21.18	0-2	2
	1851.5	18615	3	16QAM	8	7	21.01	0-2	2
	1851.5	18615	3	16QAM	15	0	20.74	0-2	2
Mid	1880	18900	3	QPSK	1	0	22.85	0	0
	1880	18900	3	QPSK	1	7	22.87	0	0
	1880	18900	3	QPSK	1	14	22.73	0	0
	1880	18900	3	QPSK	8	0	21.76	0-1	1
	1880	18900	3	QPSK	8	4	21.73	0-1	1
	1880	18900	3	QPSK	8	7	21.71	0-1	1
	1880	18900	3	QPSK	15	0	21.72	0-1	1
	1880	18900	3	16QAM	1	0	22.49	0-1	1
	1880	18900	3	16QAM	1	7	22.39	0-1	1
	1880	18900	3	16QAM	1	14	21.82	0-1	1
	1880	18900	3	16QAM	8	0	21.15	0-2	2
	1880	18900	3	16QAM	8	4	21.15	0-2	2
	1880	18900	3	16QAM	8	7	21.11	0-2	2
	1880	18900	3	16QAM	15	0	21.13	0-2	2
High	1908.5	19185	3	QPSK	1	0	22.65	0	0
	1908.5	19185	3	QPSK	1	7	22.64	0	0
	1908.5	19185	3	QPSK	1	14	22.72	0	0
	1908.5	19185	3	QPSK	8	0	21.78	0-1	0-1
	1908.5	19185	3	QPSK	8	4	21.56	0-1	0-1
	1908.5	19185	3	QPSK	8	7	21.67	0-1	0-1
	1908.5	19185	3	QPSK	15	0	21.66	0-1	0-1
	1908.5	19185	3	16QAM	1	0	22.32	0-1	0-1
	1908.5	19185	3	16QAM	1	7	22.21	0-1	0-1
	1908.5	19185	3	16QAM	1	14	22.35	0-1	0-1
	1908.5	19185	3	16QAM	8	0	21.09	0-2	0-2
	1908.5	19185	3	16QAM	8	4	21.03	0-2	0-2
	1908.5	19185	3	16QAM	8	7	21.10	0-2	0-2
	1908.5	19185	3	16QAM	15	0	21.03	0-2	0-2

Table 10.3.17The power was measured by CMW500

Mode	Freq. (MHz)	Channel	LTE Band 2 (PCS) Conducted Power- 1.4 MHz Bandwidth						
			Bandwidth (MHz)	Modulation	RB Size	RB Offset	Conducted Power(dBm)	MPRAllowed Per 3GPP(dB)	MPR (dB)
Low	1850.7	18607	1.4	QPSK	1	0	22.64	0	0
	1850.7	18607	1.4	QPSK	1	2	22.79	0	0
	1850.7	18607	1.4	QPSK	1	5	22.61	0	0
	1850.7	18607	1.4	QPSK	3	0	22.60	0-1	0-1
	1850.7	18607	1.4	QPSK	3	2	22.68	0-1	0-1
	1850.7	18607	1.4	QPSK	3	3	22.65	0-1	0-1
	1850.7	18607	1.4	QPSK	6	0	21.54	0-1	0-1
	1850.7	18607	1.4	16QAM	1	0	22.04	0-1	0-1
	1850.7	18607	1.4	16QAM	1	2	22.23	0-1	0-1
	1850.7	18607	1.4	16QAM	1	5	21.82	0-1	0-1
	1850.7	18607	1.4	16QAM	3	0	21.72	0-2	0-2
	1850.7	18607	1.4	16QAM	3	2	21.56	0-2	0-2
	1850.7	18607	1.4	16QAM	3	3	22.04	0-2	0-2
	1850.7	18607	1.4	16QAM	6	0	20.64	0-2	0-2
Mid	1880	18900	1.4	QPSK	1	0	22.77	0	0
	1880	18900	1.4	QPSK	1	2	22.82	0	0
	1880	18900	1.4	QPSK	1	5	22.75	0	0
	1880	18900	1.4	QPSK	3	0	22.85	0-1	0-1
	1880	18900	1.4	QPSK	3	2	22.89	0-1	0-1
	1880	18900	1.4	QPSK	3	3	22.85	0-1	0-1
	1880	18900	1.4	QPSK	6	0	21.72	0-1	0-1
	1880	18900	1.4	16QAM	1	0	22.44	0-1	0-1
	1880	18900	1.4	16QAM	1	2	22.37	0-1	0-1
	1880	18900	1.4	16QAM	1	5	22.44	0-1	0-1
	1880	18900	1.4	16QAM	3	0	21.94	0-2	0-2
	1880	18900	1.4	16QAM	3	2	21.97	0-2	0-2
	1880	18900	1.4	16QAM	3	3	22.12	0-2	0-2
1880	18900	1.4	16QAM	6	0	20.82	0-2	0-2	
High	1909.3	19193	1.4	QPSK	1	0	22.57	0	0
	1909.3	19193	1.4	QPSK	1	2	22.72	0	0
	1909.3	19193	1.4	QPSK	1	5	22.78	0	0
	1909.3	19193	1.4	QPSK	3	0	22.78	0-1	0-1
	1909.3	19193	1.4	QPSK	3	2	22.82	0-1	0-1
	1909.3	19193	1.4	QPSK	3	3	22.77	0-1	0-1
	1909.3	19193	1.4	QPSK	6	0	21.67	0-1	0-1
	1909.3	19193	1.4	16QAM	1	0	22.31	0-1	0-1
	1909.3	19193	1.4	16QAM	1	2	22.34	0-1	0-1
	1909.3	19193	1.4	16QAM	1	5	22.40	0-1	0-1
	1909.3	19193	1.4	16QAM	3	0	22.10	0-2	0-2
	1909.3	19193	1.4	16QAM	3	2	22.06	0-2	0-2
	1909.3	19193	1.4	16QAM	3	3	22.00	0-2	0-2
1909.3	19193	1.4	16QAM	6	0	20.84	0-2	0-2	

Table 10.3.18The power was measured by CMW500

5) LTE Band 7

Mode	Freq. (MHz)	Channel	LTE Band 7 Conducted Power– 20 MHz Bandwidth						
			Bandwidth (MHz)	Modulation	RB Size	RB Offset	Conducted Power(dBm)	MPRAllowed Per 3GPP(dB)	MPR (dB)
Low	2510	20850	20	QPSK	1	0	23.05	0	0
	2510	20850	20	QPSK	1	50	22.58	0	0
	2510	20850	20	QPSK	1	99	22.39	0	0
	2510	20850	20	QPSK	50	0	21.30	0-1	1
	2510	20850	20	QPSK	50	25	21.23	0-1	1
	2510	20850	20	QPSK	50	50	21.12	0-1	1
	2510	20850	20	QPSK	100	0	21.23	0-1	1
	2510	20850	20	16QAM	1	0	21.83	0-1	1
	2510	20850	20	16QAM	1	50	21.76	0-1	1
	2510	20850	20	16QAM	1	99	21.66	0-1	1
	2510	20850	20	16QAM	50	0	20.28	0-2	2
	2510	20850	20	16QAM	50	25	20.18	0-2	2
	2510	20850	20	16QAM	50	50	20.11	0-2	2
	2510	20850	20	16QAM	100	0	20.20	0-2	2
Mid	2535	21100	20	QPSK	1	0	22.99	0	0
	2535	21100	20	QPSK	1	50	23.00	0	0
	2535	21100	20	QPSK	1	99	22.87	0	0
	2535	21100	20	QPSK	50	0	21.66	0-1	1
	2535	21100	20	QPSK	50	25	21.60	0-1	1
	2535	21100	20	QPSK	50	50	21.56	0-1	1
	2535	21100	20	QPSK	100	0	21.65	0-1	1
	2535	21100	20	16QAM	1	0	22.32	0-1	1
	2535	21100	20	16QAM	1	50	22.32	0-1	1
	2535	21100	20	16QAM	1	99	22.14	0-1	1
	2535	21100	20	16QAM	50	0	20.65	0-2	2
	2535	21100	20	16QAM	50	25	20.70	0-2	2
	2535	21100	20	16QAM	50	50	20.45	0-2	2
	2535	21100	20	16QAM	100	0	20.52	0-2	2
High	2560	21350	20	QPSK	1	0	23.00	0	0
	2560	21350	20	QPSK	1	50	22.82	0	0
	2560	21350	20	QPSK	1	99	22.78	0	0
	2560	21350	20	QPSK	50	0	21.68	0-1	1
	2560	21350	20	QPSK	50	25	21.60	0-1	1
	2560	21350	20	QPSK	50	50	21.45	0-1	1
	2560	21350	20	QPSK	100	0	21.58	0-1	1
	2560	21350	20	16QAM	1	0	22.45	0-1	1
	2560	21350	20	16QAM	1	50	22.23	0-1	1
	2560	21350	20	16QAM	1	99	21.47	0-1	1
	2560	21350	20	16QAM	50	0	20.66	0-2	2
	2560	21350	20	16QAM	50	25	20.60	0-2	2
	2560	21350	20	16QAM	50	50	20.46	0-2	2
	2560	21350	20	16QAM	100	0	20.54	0-2	2

Table 10.3.19The power was measured by CMW500

Mode	Freq. (MHz)	Channel	LTE Band 7 Conducted Power– 15 MHz Bandwidth						
			Bandwidth (MHz)	Modulation	RB Size	RB Offset	Conducted Power(dBm)	MPRAllowed Per 3GPP(dB)	MPR (dB)
Low	2507.5	20825	15	QPSK	1	0	22.97	0	0
	2507.5	20825	15	QPSK	1	36	22.61	0	0
	2507.5	20825	15	QPSK	1	74	22.63	0	0
	2507.5	20825	15	QPSK	36	0	21.54	0-1	1
	2507.5	20825	15	QPSK	36	18	21.38	0-1	1
	2507.5	20825	15	QPSK	36	37	21.32	0-1	1
	2507.5	20825	15	QPSK	75	0	21.40	0-1	1
	2507.5	20825	15	16QAM	1	0	22.20	0-1	1
	2507.5	20825	15	16QAM	1	36	21.88	0-1	1
	2507.5	20825	15	16QAM	1	74	21.95	0-1	1
	2507.5	20825	15	16QAM	36	0	20.41	0-2	2
	2507.5	20825	15	16QAM	36	18	20.42	0-2	2
	2507.5	20825	15	16QAM	36	37	20.49	0-2	2
	2507.5	20825	15	16QAM	75	0	20.37	0-2	2
Mid	2535	21100	15	QPSK	1	0	22.55	0	0
	2535	21100	15	QPSK	1	36	22.43	0	0
	2535	21100	15	QPSK	1	74	22.71	0	0
	2535	21100	15	QPSK	36	0	21.48	0-1	1
	2535	21100	15	QPSK	36	18	21.33	0-1	1
	2535	21100	15	QPSK	36	37	21.38	0-1	1
	2535	21100	15	QPSK	75	0	21.38	0-1	1
	2535	21100	15	16QAM	1	0	22.04	0-1	1
	2535	21100	15	16QAM	1	36	21.93	0-1	1
	2535	21100	15	16QAM	1	74	21.94	0-1	1
	2535	21100	15	16QAM	36	0	20.47	0-2	2
	2535	21100	15	16QAM	36	18	20.32	0-2	2
	2535	21100	15	16QAM	36	37	20.40	0-2	2
	2535	21100	15	16QAM	75	0	20.48	0-2	2
High	2562.5	21375	15	QPSK	1	0	23.01	0	0
	2562.5	21375	15	QPSK	1	36	22.73	0	0
	2562.5	21375	15	QPSK	1	74	22.79	0	0
	2562.5	21375	15	QPSK	36	0	21.54	0-1	1
	2562.5	21375	15	QPSK	36	18	21.44	0-1	1
	2562.5	21375	15	QPSK	36	37	21.39	0-1	1
	2562.5	21375	15	QPSK	75	0	21.52	0-1	1
	2562.5	21375	15	16QAM	1	0	22.35	0-1	1
	2562.5	21375	15	16QAM	1	36	22.23	0-1	1
	2562.5	21375	15	16QAM	1	74	22.17	0-1	1
	2562.5	21375	15	16QAM	36	0	20.65	0-2	2
	2562.5	21375	15	16QAM	36	18	20.54	0-2	2
	2562.5	21375	15	16QAM	36	37	20.50	0-2	2
	2562.5	21375	15	16QAM	75	0	20.60	0-2	2

Table 10.3.20The power was measured by CMW500

Mode	Freq. (MHz)	Channel	LTE Band 7 Conducted Power– 10 MHz Bandwidth						
			Bandwidth (MHz)	Modulation	RB Size	RB Offset	Conducted Power(dBm)	MPRAllowed Per 3GPP(dB)	MPR (dB)
Low	2505	20800	10	QPSK	1	0	23.06	0	0
	2505	20800	10	QPSK	1	25	22.93	0	0
	2505	20800	10	QPSK	1	49	22.62	0	0
	2505	20800	10	QPSK	25	0	21.50	0-1	1
	2505	20800	10	QPSK	25	12	21.43	0-1	1
	2505	20800	10	QPSK	25	25	21.46	0-1	1
	2505	20800	10	QPSK	50	0	21.50	0-1	1
	2505	20800	10	16QAM	1	0	22.06	0-1	1
	2505	20800	10	16QAM	1	25	22.03	0-1	1
	2505	20800	10	16QAM	1	49	21.89	0-1	1
	2505	20800	10	16QAM	25	0	20.79	0-2	2
	2505	20800	10	16QAM	25	12	20.72	0-2	2
	2505	20800	10	16QAM	25	25	20.69	0-2	2
	2505	20800	10	16QAM	50	0	20.46	0-2	2
Mid	2535	21100	10	QPSK	1	0	22.96	0	0
	2535	21100	10	QPSK	1	25	22.74	0	0
	2535	21100	10	QPSK	1	49	22.77	0	0
	2535	21100	10	QPSK	25	0	21.46	0-1	1
	2535	21100	10	QPSK	25	12	21.43	0-1	1
	2535	21100	10	QPSK	25	25	21.36	0-1	1
	2535	21100	10	QPSK	50	0	21.34	0-1	1
	2535	21100	10	16QAM	1	0	22.01	0-1	1
	2535	21100	10	16QAM	1	25	21.98	0-1	1
	2535	21100	10	16QAM	1	49	22.02	0-1	1
	2535	21100	10	16QAM	25	0	20.60	0-2	2
	2535	21100	10	16QAM	25	12	20.46	0-2	2
	2535	21100	10	16QAM	25	25	20.29	0-2	2
	2535	21100	10	16QAM	50	0	20.42	0-2	2
High	2567.5	21400	10	QPSK	1	0	22.98	0	0
	2567.5	21400	10	QPSK	1	25	22.74	0	0
	2567.5	21400	10	QPSK	1	49	22.70	0	0
	2567.5	21400	10	QPSK	25	0	21.51	0-1	1
	2567.5	21400	10	QPSK	25	12	21.41	0-1	1
	2567.5	21400	10	QPSK	25	25	21.37	0-1	1
	2567.5	21400	10	QPSK	50	0	21.46	0-1	1
	2567.5	21400	10	16QAM	1	0	22.01	0-1	1
	2567.5	21400	10	16QAM	1	25	22.10	0-1	1
	2567.5	21400	10	16QAM	1	49	21.91	0-1	1
	2567.5	21400	10	16QAM	25	0	20.65	0-2	2
	2567.5	21400	10	16QAM	25	12	20.43	0-2	2
	2567.5	21400	10	16QAM	25	25	20.52	0-2	2
	2567.5	21400	10	16QAM	50	0	20.48	0-2	2

Table 10.3.21The power was measured by CMW500

Mode	Freq. (MHz)	Channel	LTE Band 7 Conducted Power– 5 MHz Bandwidth						
			Bandwidth (MHz)	Modulation	RB Size	RB Offset	Conducted Power(dBm)	MPRAllowed Per 3GPP(dB)	MPR (dB)
Low	2502.5	20775	5	QPSK	1	0	22.65	0	0
	2502.5	20775	5	QPSK	1	12	22.40	0	0
	2502.5	20775	5	QPSK	1	24	22.60	0	0
	2502.5	20775	5	QPSK	12	0	21.44	0-1	1
	2502.5	20775	5	QPSK	12	6	21.41	0-1	1
	2502.5	20775	5	QPSK	12	13	21.42	0-1	1
	2502.5	20775	5	QPSK	25	0	21.39	0-1	1
	2502.5	20775	5	16QAM	1	0	22.04	0-1	1
	2502.5	20775	5	16QAM	1	12	21.87	0-1	1
	2502.5	20775	5	16QAM	1	24	21.87	0-1	1
	2502.5	20775	5	16QAM	12	0	20.48	0-2	2
	2502.5	20775	5	16QAM	12	6	20.43	0-2	2
	2502.5	20775	5	16QAM	12	13	20.62	0-2	2
	2502.5	20775	5	16QAM	25	0	20.49	0-2	2
Mid	2535	21100	5	QPSK	1	0	22.55	0	0
	2535	21100	5	QPSK	1	12	22.74	0	0
	2535	21100	5	QPSK	1	24	22.68	0	0
	2535	21100	5	QPSK	12	0	21.38	0-1	1
	2535	21100	5	QPSK	12	6	21.32	0-1	1
	2535	21100	5	QPSK	12	13	21.37	0-1	1
	2535	21100	5	QPSK	25	0	21.27	0-1	1
	2535	21100	5	16QAM	1	0	21.93	0-1	1
	2535	21100	5	16QAM	1	12	21.89	0-1	1
	2535	21100	5	16QAM	1	24	21.87	0-1	1
	2535	21100	5	16QAM	12	0	20.41	0-2	2
	2535	21100	5	16QAM	12	6	20.33	0-2	2
	2535	21100	5	16QAM	12	13	20.32	0-2	2
	2535	21100	5	16QAM	25	0	20.37	0-2	2
High	2567.5	21425	5	QPSK	1	0	22.72	0	0
	2567.5	21425	5	QPSK	1	12	22.62	0	0
	2567.5	21425	5	QPSK	1	24	22.63	0	0
	2567.5	21425	5	QPSK	12	0	21.39	0-1	1
	2567.5	21425	5	QPSK	12	6	21.44	0-1	1
	2567.5	21425	5	QPSK	12	13	21.41	0-1	1
	2567.5	21425	5	QPSK	25	0	21.37	0-1	1
	2567.5	21425	5	16QAM	1	0	21.89	0-1	1
	2567.5	21425	5	16QAM	1	12	21.84	0-1	1
	2567.5	21425	5	16QAM	1	24	21.86	0-1	1
	2567.5	21425	5	16QAM	12	0	20.44	0-2	2
	2567.5	21425	5	16QAM	12	6	20.47	0-2	2
	2567.5	21425	5	16QAM	12	13	20.45	0-2	2
	2567.5	21425	5	16QAM	25	0	20.74	0-2	2

Table 10.3.22The power was measured by CMW500

10.4 WLAN Conducted Powers

Mode	Freq. (MHz)	Channel	802.11b (2.4 GHz) Conducted Power (dBm)			
			Data Rate (Mbps)			
	1	2	5.5	11		
802.11b	2412	1	13.98	13.92	13.85	13.88
	2437	6	<u>14.46</u>	14.41	14.38	14.42
	2462	11	13.94	13.85	13.87	13.91

Table 10.4.1 IEEE 802.11b Average RF Power

Mode	Freq. (MHz)	Channel	802.11g (2.4 GHz) Conducted Power (dBm)							
			Data Rate (Mbps)							
	6	9	12	18	24	36	48	54		
802.11g	2412	1	10.94	10.85	10.91	10.84	10.81	10.91	10.88	10.87
	2437	6	11.14	11.08	11.04	11.11	11.01	11.02	11.04	10.98
	2462	11	10.56	10.55	10.51	10.49	10.45	10.47	10.52	10.46

Table 10.4.2 IEEE 802.11g Average RF Power

Mode	Freq. (MHz)	Channel	802.11n HT20 (2.4 GHz) Conducted Power (dBm)							
			Data Rate (Mbps)							
	6.5	13	19.5	26	39	52	58.5	65		
802.11n (HT-20)	2412	1	10.03	9.98	9.95	10.01	9.91	9.89	9.85	9.97
	2437	6	10.23	10.11	10.21	10.14	10.16	10.07	10.13	10.15
	2462	11	9.62	9.55	9.42	9.48	9.46	9.51	9.47	9.57

Table 10.4.3 IEEE 802.11n HT20 Average RF Power

Justification for reduced test configurations for WIFI channels per KDB Publication 248227 D01v02 and October 2012 / April 2013 FCC/TCB Meeting Notes:

- For 2.4 GHz, highest average RF output power channel for the lowest data rate for IEEE 802.11b were selected for SAR evaluation. Other IEEE 802.11 modes (including 802.11g/n) were not investigated since the average output powers over all channels and data rates were not more than 0.25 dB higher than the tested channel in the lowest data rate of IEEE 802.11b mode.
- When the maximum extrapolated peak SAR of the zoom scan for the maximum output channel is <1.6 W/kg and the reported 1g averaged SAR is <0.8 W/kg, SAR testing on other channels is not required. Otherwise, the other default (or corresponding required) test channels were additionally tested using the lowest data rate.
- The underlined data rate and channel above were tested for SAR.

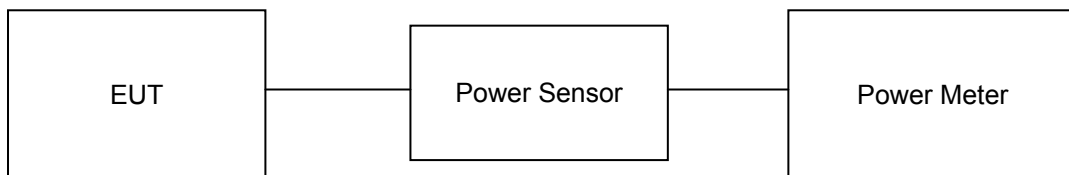

Figure 10.3 Average Power Measurement Setup

10.5 Bluetooth Conducted Powers

Channel	Frequency	Frame AVG Output Power (1Mbps)		Frame AVG Output Power (2Mbps)		Frame AVG Output Power (3Mbps)	
	(MHz)	(dBm)	(mW)	(dBm)	(mW)	(dBm)	(mW)
Low	2402	7.45	5.559	4.96	3.133	4.97	3.141
Mid	2441	7.59	5.741	5.12	3.251	5.14	3.266
High	2480	6.80	4.786	4.32	2.704	4.33	2.710

Table 10.5.1 Bluetooth Frame Average RF Power

Channel	Frequency	Frame AVG Output Power (LE)	
	(MHz)	(dBm)	(mW)
Low	2402	-2.21	0.601
Mid	2440	-1.99	0.632
High	2480	-2.92	0.511

Table 10.5.2 Bluetooth LE Frame Average RF Power

● **Bluetooth Conducted Powers procedures**

1. Bluetooth (BDR, EDR)

1) Enter DUT mode in EUT and operate it.

When it operating, The EUT is transmitting at maximum power level and duty cycle fixed.

2) Instruments and EUT were connected like Figure 10.4(A).

3) The maximum output powers of BDR(1 Mbps), EDR(2, 3 Mbps) and each frequency were set by a Bluetooth Tester.

4) Power levels were measured by a Power Meter.

2. Bluetooth (LE)

1) Enter LE mode in EUT and operate it.

When it operating, The EUT is transmitting at maximum power level and duty cycle fixed.

2) Instruments and EUT were connected like Figure 10.4(B).

3) The average conducted output powers of LE and each frequency can measurement according to setting program in EUT.

4) Power levels were measured by a Power Meter.

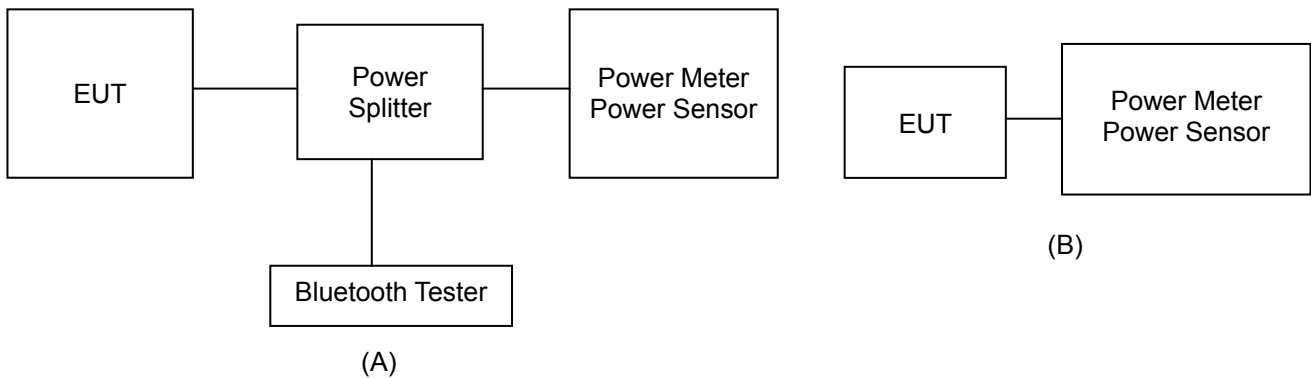

Figure 10.4 Average Power Measurement Setup

The average conducted output powers of Bluetooth were measured using above test setup and a wideband gated RF power meter when the EUT is transmitting at its maximum power level.

11. SYSTEM VERIFICATION

11.1 Tissue Verification

MEASURED TISSUE PARAMETERS										
Date(s)	Tissue Type	Ambient Temp.[°C]	Liquid Temp.[°C]	Measured Frequency [MHz]	Target Dielectric Constant, ϵ_r	Target Conductivity, σ (S/m)	Measured Dielectric Constant, ϵ_r	Measured Conductivity, σ (S/m)	ErDeviation [%]	σ Deviation [%]
May. 13. 2015	750 Head	22.1	22.7	709.0	42.119	0.887	42.144	0.888	0.06	0.11
				711.0	42.108	0.887	42.084	0.889	-0.06	0.23
				750.0	41.900	0.890	41.556	0.923	-0.82	3.71
May. 13. 2015	750 Body	22.1	22.7	709.0	55.691	0.960	56.227	0.963	0.96	0.31
				711.0	55.683	0.960	56.203	0.964	0.93	0.42
				750.0	55.531	0.963	55.791	0.998	0.47	3.63
May. 04. 2015	835 Head	21.3	21.7	824.2	41.552	0.899	40.424	0.880	-2.71	-2.11
				835.0	41.500	0.900	40.308	0.890	-2.87	-1.11
				836.6	41.500	0.901	40.293	0.891	-2.91	-1.11
				848.8	41.500	0.914	40.161	0.902	-3.23	-1.31
May. 04. 2015	835 Body	21.3	21.7	824.2	55.243	0.969	55.264	0.985	0.04	1.65
				835.0	55.200	0.970	55.177	0.994	-0.04	2.47
				836.6	55.197	0.971	55.160	0.996	-0.07	2.57
				848.8	55.160	0.986	55.048	1.006	-0.20	2.03
May. 09. 2015	835 Head	22.0	22.6	826.4	41.542	0.899	41.933	0.905	0.94	0.67
				835.0	41.500	0.900	41.835	0.913	0.81	1.44
				836.6	41.500	0.901	41.814	0.915	0.76	1.55
				846.6	41.500	0.912	41.690	0.923	0.46	1.21
May. 09. 2015	835 Body	22.0	22.6	826.4	55.235	0.969	55.518	0.989	0.51	2.06
				835.0	55.200	0.970	55.445	0.997	0.44	2.78
				836.6	55.197	0.971	55.430	0.998	0.42	2.78
				846.6	55.166	0.984	55.348	1.007	0.33	2.34
May. 08. 2015	835 Head	21.8	22.4	829.0	41.528	0.899	41.817	0.881	0.70	-2.00
				835.0	41.500	0.900	41.764	0.885	0.64	-1.67
				836.5	41.500	0.901	41.746	0.887	0.59	-1.55
				844.0	41.500	0.910	41.670	0.893	0.41	-1.87
May. 08. 2015	835 Body	21.8	22.4	829.0	55.223	0.970	54.925	0.998	-0.54	2.89
				835.0	55.200	0.970	54.875	1.004	-0.59	3.51
				836.5	55.197	0.971	54.869	1.005	-0.59	3.50
				844.0	55.172	0.981	54.793	1.012	-0.69	3.16
May. 07. 2015	1800 Head	22.1	22.5	1720.0	40.114	1.354	40.982	1.307	2.16	-3.47
				1732.5	40.097	1.361	40.923	1.317	2.06	-3.23
				1745.0	40.079	1.369	40.877	1.329	1.99	-2.92
				1800.0	40.000	1.400	40.693	1.384	1.73	-1.14
May. 07. 2015	1800 Body	22.1	22.5	1720.0	53.580	1.469	52.982	1.468	-1.12	-0.07
				1732.5	53.556	1.477	52.951	1.477	-1.13	0.00
				1745.0	53.530	1.485	52.927	1.487	-1.13	0.13
				1800.0	53.300	1.520	52.836	1.537	-0.87	1.12
May. 01. 2015	1900 Head	21.7	22.1	1850.2	40.000	1.400	40.711	1.371	1.78	-2.07
				1880.0	40.000	1.400	40.695	1.398	1.74	-0.14
				1900.0	40.000	1.400	40.650	1.416	1.63	1.14
				1909.8	40.000	1.400	40.626	1.426	1.56	1.86
May. 01. 2015	1900 Body	21.7	22.1	1850.2	53.300	1.520	52.342	1.504	-1.80	-1.05
				1880.0	53.300	1.520	52.316	1.528	-1.85	0.53
				1900.0	53.300	1.520	52.271	1.544	-1.93	1.58
				1909.8	53.300	1.520	52.256	1.552	-1.96	2.11
May. 02. 2015	1900 Head	21.9	22.3	1852.4	40.000	1.400	40.384	1.365	0.96	-2.50
				1880.0	40.000	1.400	40.362	1.392	0.91	-0.57
				1900.0	40.000	1.400	40.316	1.411	0.79	0.79
				1907.6	40.000	1.400	40.296	1.419	0.74	1.36
May. 02. 2015	1900 Body	21.9	22.3	1852.4	53.300	1.520	52.325	1.482	-1.83	-2.50
				1880.0	53.300	1.520	52.311	1.504	-1.86	-1.05
				1900.0	53.300	1.520	52.278	1.520	-1.92	0.00
				1907.6	53.300	1.520	52.264	1.527	-1.94	0.46

MEASURED TISSUE PARAMETERS										
Date(s)	Tissue Type	Ambient Temp.[°C]	Liquid Temp.[°C]	Measured Frequency [MHz]	Target Dielectric Constant, ϵ_r	Target Conductivity, σ (S/m)	Measured Dielectric Constant, ϵ_r	Measured Conductivity, σ (S/m)	ErDeviation [%]	σ Deviation [%]
May. 06. 2015	1900 Head	21.6	22.0	1860.0	40.000	1.400	40.126	1.382	0.31	-1.29
				1880.0	40.000	1.400	40.052	1.401	0.13	0.07
				1900.0	40.000	1.400	39.986	1.420	-0.04	1.43
May. 06. 2015	1900 Body	21.6	22.0	1860.0	53.300	1.520	52.371	1.511	-1.74	-0.59
				1880.0	53.300	1.520	52.345	1.527	-1.79	0.46
				1900.0	53.300	1.520	52.305	1.543	-1.87	1.51
May. 12. 2015	2450 Head	21.9	22.5	2412.0	39.265	1.766	40.226	1.790	2.45	1.36
				2437.0	39.222	1.788	40.352	1.817	2.88	1.62
				2450.0	39.200	1.800	40.313	1.832	2.84	1.78
				2462.0	39.184	1.813	40.290	1.845	2.82	1.77
May. 12. 2015	2450 Body	21.9	22.5	2412.0	52.751	1.914	51.139	1.935	-3.06	1.10
				2437.0	52.717	1.938	51.073	1.964	-3.12	1.34
				2450.0	52.700	1.950	51.033	1.980	-3.16	1.54
				2462.0	52.685	1.967	51.005	1.993	-3.19	1.32
May. 11. 2015	2600 Head	21.6	22.1	2510.0	39.120	1.864	38.769	1.903	-0.90	2.09
				2535.0	39.087	1.891	38.679	1.929	-1.04	2.01
				2560.0	39.053	1.917	38.591	1.958	-1.18	2.14
				2600.0	39.000	1.960	38.457	2.004	-1.39	2.24
May. 11. 2015	2600 Body	21.6	22.1	2510.0	52.624	2.035	52.031	2.008	-1.13	-1.33
				2535.0	52.592	2.071	51.995	2.037	-1.14	-1.64
				2560.0	52.560	2.106	51.954	2.066	-1.15	-1.90
				2600.0	52.509	2.163	51.878	2.113	-1.20	-2.31

The above measured tissue parameters were used in the DASY software. The DASY software was used to perform interpolation to determine the dielectric parameters at the SAR test device frequencies (perKDB 865664 and IEEE 1528-2013 6.6.1.2). The tissue parameters listed in the SAR test plots may slightly differ from the table above due to significant digit rounding in the software.

Measurement Procedure for Tissue verification:

- 1) The network analyzer and probe system was configured and calibrated.
- 2) The probe was immersed in the sample which was placed in a nonmetallic container. Trapped air bubbles beneath the flange were minimized by placing the probe at a slight angle.
- 3) The complex admittance with respect to the probe aperture was measured
- 4) The complex relative permittivity, for example from the below equation (Pournaropoulos and Misra):

$$Y = \frac{j2\omega\epsilon_r\epsilon_0}{[\ln(b/a)]^2} \int_a^b \int_a^b \int_0^\pi \cos\phi' \frac{\exp[-j\omega r(\mu_0\epsilon_r\epsilon_0)^{1/2}]}{r} d\phi' d\rho' d\rho$$

where Y is the admittance of the probe in contact with the sample, the primed and unprimed coordinates refer to source and observation points, respectively, $r^2 = \rho^2 + \rho'^2 - 2\rho\rho'\cos\phi'$, ω is the angular frequency, and $j = \sqrt{-1}$.

11.2 Test System Verification

Prior to assessment, the system is verified to the ± 10 % of the specifications at 750 MHz, 835 MHz, 1900 MHz, 2450 MHz and 2600 MHz by using the SAR Dipole kit(s). (Graphic Plots Attached)

SYSTEM DIPOLE VERIFICATION TARGET & MEASURED												
SAR System #	Freq. [MHz]	SAR Dipole kits	Date(s)	Tissue Type	Ambient Temp.[°C]	Liquid Temp.[°C]	Probe S/N	Input Power (mW)	1 W Target SAR _{1g} (W/kg)	Measured SAR _{1g} (W/kg)	1 W Normalized SAR _{1g} (W/kg)	Deviation [%]
B	750	D750V3, SN:1049	May. 13. 2015	Head	22.1	22.7	3328	250	8.22	2.17	8.68	5.60
B	750	D750V3, SN:1049	May. 13. 2015	Body	22.1	22.7	3328	250	8.56	2.09	8.36	-2.34
B	835	D835V2, SN:4d159	May. 04. 2015	Head	21.3	21.7	3328	250	9.19	2.34	9.36	1.85
B	835	D835V2, SN: 4d159	May. 04. 2015	Body	21.3	21.7	3328	250	9.64	2.58	10.32	7.05
B	835	D835V2, SN:4d159	May. 09. 2015	Head	22.0	22.6	3328	250	9.19	2.42	9.68	5.33
B	835	D835V2, SN:4d159	May. 09. 2015	Body	22.0	22.6	3328	250	9.64	2.49	9.96	3.32
B	835	D835V2, SN:4d159	May. 08. 2015	Head	21.8	22.4	3328	250	9.19	2.27	9.08	-1.20
B	835	D835V2, SN: 4d159	May. 08. 2015	Body	21.8	22.4	3328	250	9.64	2.44	9.76	1.24
B	1800	D1800V2, SN:2d047	May. 07. 2015	Head	22.1	22.5	3328	250	38.80	9.84	39.36	1.44
B	1800	D1800V2, SN:2d047	May. 07. 2015	Body	22.1	22.5	3328	250	38.10	9.46	37.84	-0.68
B	1900	D1900V2, SN:5d176	May. 01. 2015	Head	21.7	22.1	3328	250	40.10	10.10	40.40	0.75
B	1900	D1900V2, SN: 5d176	May. 01. 2015	Body	21.7	22.1	3328	250	40.00	10.20	40.80	2.00
B	1900	D1900V2, SN:5d176	May. 02. 2015	Head	21.9	22.3	3328	250	40.10	10.30	41.20	2.74
B	1900	D1900V2, SN: 5d176	May. 02. 2015	Body	21.9	22.3	3328	250	40.00	10.50	42.00	5.00
B	1900	D1900V2, SN:5d176	May. 06. 2015	Head	21.6	22.0	3328	250	40.10	9.80	39.20	-2.24
B	1900	D1900V2, SN:5d176	May. 06. 2015	Body	21.6	22.0	3328	250	40.00	10.10	40.40	1.00
B	2450	D2450V2, SN:920	May. 12. 2015	Head	21.9	22.5	3328	250	52.70	12.00	48.00	-8.92
B	2450	D2450V2, SN: 920	May. 12. 2015	Body	21.9	22.5	3328	250	51.40	12.90	51.60	0.39
B	2600	D2600V2, SN:1103	May. 11. 2015	Head	21.6	22.1	3930	250	56.50	14.80	59.20	4.78
B	2600	D2600V2, SN:1103	May. 11. 2015	Body	21.6	22.1	3930	250	56.20	13.90	55.60	-1.07

Note1 : System Verification was measured with input 250 mW and normalized to 1W.

Note2 : To confirm the proper SAR liquid depth, the z-axis plots from the system verifications were included since the system verifications were performed using the same liquid, probe and DAE as the SAR tests in the same time period.

Note3: Full system validation status and results can be found in Attachment 3.

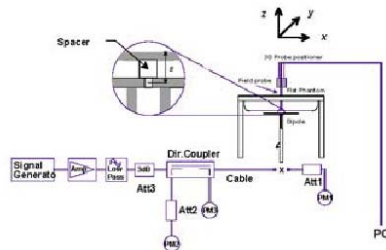

Figure 11.1 Dipole Verification Test Setup Diagram & Photo

12. SAR TEST RESULTS

12.1 Head SAR Results

Table 12.1 GSM/GPRS 850 Head SAR

MEASUREMENT RESULTS														
FREQUENCY		Mode/ Band	Service	Maximum Allowed Power [dBm]	Conducted Power [dBm]	Drift Power [dB]	Phantom Position	Device Serial Number	# of Time Slots	Duty Cycle	1g SAR (W/kg)	Scaling Factor	1g Scaled SAR (W/kg)	Plots #
MHz	Ch													
836.6	190	GSM850	GSM	33.70	33.60	0.170	Left Touch	FCC #1	1	1:8.3	0.340	1.023	0.348	
836.6	190	GSM850	GSM	33.70	33.60	0.070	Right Touch	FCC #1	1	1:8.3	0.331	1.023	0.339	
836.6	190	GSM850	GSM	33.70	33.60	-0.040	Left Tilt	FCC #1	1	1:8.3	0.218	1.023	0.223	
836.6	190	GSM850	GSM	33.70	33.60	-0.040	Right Tilt	FCC #1	1	1:8.3	0.187	1.023	0.191	
836.6	190	GSM850	GPRS	33.70	33.60	0.040	Left Touch	FCC #1	1	1:8.3	0.351	1.023	0.359	
836.6	190	GSM850	GPRS	30.70	30.40	0.180	Left Touch	FCC #1	2	1:4.15	0.295	1.072	0.316	
836.6	190	GSM850	GPRS	29.20	29.10	0.020	Left Touch	FCC #1	3	1:2.77	0.326	1.023	0.333	
836.6	190	GSM850	GPRS	27.70	27.60	0.110	Left Touch	FCC #1	4	1:2.075	0.419	1.023	0.429	A1
836.6	190	GSM850	GPRS	27.70	27.60	0.140	Right Touch	FCC #1	4	1:2.075	0.345	1.023	0.353	
836.6	190	GSM850	GPRS	27.70	27.60	-0.000	Left Tilt	FCC #1	4	1:2.075	0.218	1.023	0.223	
836.6	190	GSM850	GPRS	27.70	27.60	-0.180	Right Tilt	FCC #1	4	1:2.075	0.197	1.023	0.202	
836.6	190	GSM850	GPRS	27.70	27.60	0.020	Left Touch	FCC #1	4	1:2.075	0.352	1.023	0.360	
ANSI / IEEE C95.1-2005- SAFETY LIMIT Spatial Peak Uncontrolled Exposure/General Population Exposure								Head 1.6 W/kg (mW/g) averaged over 1 gram						

Note : Blue entries represent were tested with sim2 on the worst case sim1 tests.

Table 12.2 PCS/GPRS 1900 Head SAR

MEASUREMENT RESULTS														
FREQUENCY		Mode/ Band	Service	Maximum Allowed Power [dBm]	Conducted Power [dBm]	Drift Power [dB]	Phantom Position	Device Serial Number	# of Time Slots	Duty Cycle	1g SAR (W/kg)	Scaling Factor	1g Scaled SAR (W/kg)	Plots #
MHz	Ch													
1880.0	661	PCS1900	PCS	31.20	30.60	-0.150	Left Touch	FCC #1	1	1:8.3	0.397	1.148	0.456	
1880.0	661	PCS1900	PCS	31.20	30.60	0.180	Right Touch	FCC #1	1	1:8.3	0.218	1.148	0.250	
1880.0	661	PCS1900	PCS	31.20	30.60	0.070	Left Tilt	FCC #1	1	1:8.3	0.182	1.148	0.209	
1880.0	661	PCS1900	PCS	31.20	30.60	-0.190	Right Tilt	FCC #1	1	1:8.3	0.177	1.148	0.203	
1880.0	661	PCS1900	GPRS	31.20	30.60	0.090	Left Touch	FCC #1	1	1:8.3	0.403	1.148	0.463	
1880.0	661	PCS1900	GPRS	27.70	27.60	0.040	Left Touch	FCC #1	2	1:4.15	0.377	1.023	0.386	
1880.0	661	PCS1900	GPRS	26.20	26.00	0.130	Left Touch	FCC #1	3	1:2.77	0.489	1.047	0.512	A2
1880.0	661	PCS1900	GPRS	24.70	24.60	0.070	Left Touch	FCC #1	4	1:2.075	0.357	1.023	0.365	
1880.0	661	PCS1900	GPRS	26.20	26.00	0.170	Right Touch	FCC #1	3	1:2.77	0.229	1.047	0.240	
1880.0	661	PCS1900	GPRS	26.20	26.00	0.040	Left Tilt	FCC #1	3	1:2.77	0.181	1.047	0.190	
1880.0	661	PCS1900	GPRS	26.20	26.00	-0.180	Right Tilt	FCC #1	3	1:2.77	0.187	1.047	0.196	
1880.0	661	PCS1900	GPRS	26.20	26.00	0.110	Left Touch	FCC #1	3	1:2.77	0.448	1.047	0.469	
ANSI / IEEE C95.1-2005- SAFETY LIMIT Spatial Peak Uncontrolled Exposure/General Population Exposure								Head 1.6 W/kg (mW/g) averaged over 1 gram						

Note : Blue entries represent were tested with sim2 on the worst case sim1 tests.

Table 12.3 WCDMA 850 Head SAR

MEASUREMENT RESULTS													
FREQUENCY		Mode/ Band	Service	Maximum Allowed Power [dBm]	Conducted Power [dBm]	Drift Power [dB]	Phantom Position	Device Serial Number	Duty Cycle	1g SAR (W/kg)	Scaling Factor	1g Scaled SAR (W/kg)	Plots #
MHz	Ch												
836.6	4183	WCDMA 850	RMC	24.20	24.10	0.140	Left Touch	FCC #1	1:1	0.322	1.023	0.329	
836.6	4183	WCDMA 850	RMC	24.20	24.10	0.080	Right Touch	FCC #1	1:1	0.333	1.023	0.341	A3
836.6	4183	WCDMA 850	RMC	24.20	24.10	0.010	Left Tilt	FCC #1	1:1	0.252	1.023	0.258	
836.6	4183	WCDMA 850	RMC	24.20	24.10	0.000	Right Tilt	FCC #1	1:1	0.206	1.023	0.211	
836.6	4183	WCDMA 850	RMC	24.20	24.10	0.030	Right Touch	FCC #1	1:1	0.331	1.023	0.339	
ANSI / IEEE C95.1-2005– SAFETY LIMIT Spatial Peak Uncontrolled Exposure/General Population Exposure									Head 1.6 W/kg (mW/g) averaged over 1 gram				

Note : Blue entries represent were tested with sim2 on the worst case sim1 tests.

Table 12.4 WCDMA 1900 Head SAR

MEASUREMENT RESULTS													
FREQUENCY		Mode/ Band	Service	Maximum Allowed Power [dBm]	Conducted Power [dBm]	Drift Power [dB]	Phantom Position	Device Serial Number	Duty Cycle	1g SAR (W/kg)	Scaling Factor	1g Scaled SAR (W/kg)	Plots #
MHz	Ch												
1880.0	9400	WCDMA 1900	RMC	23.70	23.70	0.010	Left Touch	FCC #1	1:1	0.528	1.000	0.528	A4
1880.0	9400	WCDMA 1900	RMC	23.70	23.70	0.050	Right Touch	FCC #1	1:1	0.332	1.000	0.332	
1880.0	9400	WCDMA 1900	RMC	23.70	23.70	0.080	Left Tilt	FCC #1	1:1	0.251	1.000	0.251	
1880.0	9400	WCDMA 1900	RMC	23.70	23.70	-0.140	Right Tilt	FCC #1	1:1	0.240	1.000	0.240	
1880.0	9400	WCDMA 1900	RMC	23.70	23.70	0.080	Right Touch	FCC #1	1:1	0.475	1.000	0.475	
ANSI / IEEE C95.1-2005– SAFETY LIMIT Spatial Peak Uncontrolled Exposure/General Population Exposure									Head 1.6 W/kg (mW/g) averaged over 1 gram				

Note : Blue entries represent were tested with sim2 on the worst case sim1 tests.

Table 12.5 LTE Band 17 Head SAR

MEASUREMENT RESULTS																	
FREQUENCY		Mode/ Band	BW [MHz]	Max Allowed Power [dBm]	Cond. PWR [dBm]	Drift Power [dB]	MPR	Position	Device Serial Number	Mod.	RB Size	RB Offs.	Duty Cycle	1g SAR (W/kg)	Scaling Factor	1g Scaled SAR (W/kg)	Plots #
MHz	Ch																
709.0	23780	LTE B17	10	23.70	23.60	-0.170	0	Left Touch	FCC #1	QPSK	1	49	1:1	0.233	1.023	0.238	
709.0	23780	LTE B17	10	22.70	22.37	0.060	1	Left Touch	FCC #1	QPSK	25	25	1:1	0.180	1.079	0.194	
709.0	23780	LTE B17	10	23.70	23.60	0.150	0	Right Touch	FCC #1	QPSK	1	49	1:1	0.261	1.023	0.267	A7
709.0	23780	LTE B17	10	22.70	22.37	0.010	1	Right Touch	FCC #1	QPSK	25	25	1:1	0.189	1.079	0.204	
709.0	23780	LTE B17	10	23.70	23.60	0.040	0	Left Tilt	FCC #1	QPSK	1	49	1:1	0.138	1.023	0.141	
709.0	23780	LTE B17	10	22.70	22.37	0.040	1	Left Tilt	FCC #1	QPSK	25	25	1:1	0.101	1.079	0.109	
709.0	23780	LTE B17	10	23.70	23.60	0.120	0	Right Tilt	FCC #1	QPSK	1	49	1:1	0.131	1.023	0.134	
709.0	23780	LTE B17	10	22.70	22.37	-0.000	1	Right Tilt	FCC #1	QPSK	25	25	1:1	0.102	1.079	0.110	
709.0	23780	LTE B17	10	23.70	23.60	0.090	0	Right Touch	FCC #1	QPSK	1	49	1:1	0.246	1.023	0.252	
ANSI / IEEE C95.1-2005– SAFETY LIMIT Spatial Peak Uncontrolled Exposure/General Population Exposure									Head 1.6 W/kg (mW/g) averaged over 1 gram								

Note : Blue entries represent were tested with sim2 on the worst case sim1 tests.

Table 12.6 LTE Band 5 (Cell) Head SAR

MEASUREMENT RESULTS																	
FREQUENCY		Mode/ Band	BW [MHz]	Max Allowed Power [dBm]	Cond. PWR [dBm]	Drift Power [dB]	MPR	Position	Device Serial Number	Mod.	RB Size	RB Offs.	Duty Cycle	1g SAR (W/kg)	Scaling Factor	1g Scaled SAR (W/kg)	Plots #
MHz	Ch																
844.0	20600	LTE B5	10	23.20	23.10	0.050	0	Left Touch	FCC #1	QPSK	1	49	1:1	0.377	1.023	0.386	A5
844.0	20600	LTE B5	10	22.20	21.98	0.140	1	Left Touch	FCC #1	QPSK	25	25	1:1	0.276	1.052	0.290	
844.0	20600	LTE B5	10	23.20	23.10	0.050	0	Right Touch	FCC #1	QPSK	1	49	1:1	0.361	1.023	0.369	
844.0	20600	LTE B5	10	22.20	21.98	-0.040	1	Right Touch	FCC #1	QPSK	25	25	1:1	0.275	1.052	0.289	
844.0	20600	LTE B5	10	23.20	23.10	0.120	0	Left Tilt	FCC #1	QPSK	1	49	1:1	0.242	1.023	0.248	
844.0	20600	LTE B5	10	22.20	21.98	0.040	1	Left Tilt	FCC #1	QPSK	25	25	1:1	0.185	1.052	0.195	
844.0	20600	LTE B5	10	23.20	23.10	-0.030	0	Right Tilt	FCC #1	QPSK	1	49	1:1	0.238	1.023	0.243	
844.0	20600	LTE B5	10	22.20	21.98	0.070	1	Right Tilt	FCC #1	QPSK	25	25	1:1	0.164	1.052	0.173	
844.0	20600	LTE B5	10	23.20	23.10	0.070	0	Left Touch	FCC #1	QPSK	1	49	1:1	0.373	1.023	0.382	
ANSI / IEEE C95.1-2005- SAFETY LIMIT Spatial Peak Uncontrolled Exposure/General Population Exposure										Head 1.6 W/kg (mW/g) averaged over 1 gram							

Note : Blue entries represent were tested with sim2 on the worst case sim1 tests.

Table 12.7 LTE Band 4 (AWS) Head SAR

MEASUREMENT RESULTS																	
FREQUENCY		Mode/ Band	BW [MHz]	Max Allowed Power [dBm]	Cond. PWR [dBm]	Drift Power [dB]	MPR	Position	Device Serial Number	Mod.	RB Size	RB Offs.	Duty Cycle	1g SAR (W/kg)	Scaling Factor	1g Scaled SAR (W/kg)	Plots #
MHz	Ch																
1720.0	20050	LTE B4	20	23.20	23.00	0.080	0	Left Touch	FCC #1	QPSK	1	50	1:1	0.702	1.047	0.735	A6
1720.0	20050	LTE B4	20	22.20	21.92	0.140	1	Left Touch	FCC #1	QPSK	50	0	1:1	0.537	1.067	0.573	
1720.0	20050	LTE B4	20	23.20	23.00	0.050	0	Right Touch	FCC #1	QPSK	1	50	1:1	0.345	1.047	0.361	
1720.0	20050	LTE B4	20	22.20	21.92	0.090	1	Right Touch	FCC #1	QPSK	50	0	1:1	0.276	1.067	0.294	
1720.0	20050	LTE B4	20	23.20	23.00	-0.120	0	Left Tilt	FCC #1	QPSK	1	50	1:1	0.429	1.047	0.449	
1720.0	20050	LTE B4	20	22.20	21.92	0.070	1	Left Tilt	FCC #1	QPSK	50	0	1:1	0.331	1.067	0.353	
1720.0	20050	LTE B4	20	23.20	23.00	0.060	0	Right Tilt	FCC #1	QPSK	1	50	1:1	0.264	1.047	0.276	
1720.0	20050	LTE B4	20	22.20	21.92	-0.060	1	Right Tilt	FCC #1	QPSK	50	0	1:1	0.236	1.067	0.252	
1720.0	20050	LTE B4	20	23.20	23.00	0.080	0	Left Touch	FCC #1	QPSK	1	50	1:1	0.701	1.047	0.734	
ANSI / IEEE C95.1-2005- SAFETY LIMIT Spatial Peak Uncontrolled Exposure/General Population Exposure										Head 1.6 W/kg (mW/g) averaged over 1 gram							

Note : Blue entries represent were tested with sim2 on the worst case sim1 tests.

Table 12.8 LTE Band 2 (PCS) Head SAR

MEASUREMENT RESULTS																	
FREQUENCY		Mode/ Band	BW [MHz]	Max Allowed Power [dBm]	Cond. PWR [dBm]	Drift Power [dB]	MPR	Position	Device Serial Number	Mod.	RB Size	RB Offs.	Duty Cycle	1g SAR (W/kg)	Scaling Factor	1g Scaled SAR (W/kg)	Plots #
MHz	Ch																
1860.0	18700	LTE B2	20	23.20	23.10	0.040	0	Left Touch	FCC #1	QPSK	1	0	1:1	0.495	1.023	0.506	A7
1860.0	18700	LTE B2	20	22.20	21.87	0.050	1	Left Touch	FCC #1	QPSK	50	0	1:1	0.401	1.079	0.433	
1860.0	18700	LTE B2	20	23.20	23.10	0.100	0	Right Touch	FCC #1	QPSK	1	0	1:1	0.280	1.023	0.286	
1860.0	18700	LTE B2	20	22.20	21.87	0.140	1	Right Touch	FCC #1	QPSK	50	0	1:1	0.220	1.079	0.237	
1860.0	18700	LTE B2	20	23.20	23.10	0.160	0	Left Tilt	FCC #1	QPSK	1	0	1:1	0.302	1.023	0.309	
1860.0	18700	LTE B2	20	22.20	21.87	0.180	1	Left Tilt	FCC #1	QPSK	50	0	1:1	0.233	1.079	0.251	
1860.0	18700	LTE B2	20	23.20	23.10	0.130	0	Right Tilt	FCC #1	QPSK	1	0	1:1	0.195	1.023	0.199	
1860.0	18700	LTE B2	20	22.20	21.87	0.050	1	Right Tilt	FCC #1	QPSK	50	0	1:1	0.154	1.079	0.166	
1860.0	18700	LTE B2	20	23.20	23.10	0.120	0	Left Touch	FCC #1	QPSK	1	0	1:1	0.489	1.023	0.500	
ANSI / IEEE C95.1-2005- SAFETY LIMIT Spatial Peak Uncontrolled Exposure/General Population Exposure										Head 1.6 W/kg (mW/g) averaged over 1 gram							

Note : Blue entries represent were tested with sim2 on the worst case sim1 tests.

Table 12.9 LTE Band 7 Head SAR

MEASUREMENT RESULTS																	
FREQUENCY		Mode/ Band	BW [MHz]	Max Allowed Power [dBm]	Cond. PWR [dBm]	Drift Power [dB]	MPR	Position	Device Serial Number	Mod.	RB Size	RB Offs.	Duty Cycle	1g SAR (W/kg)	Scaling Factor	1g Scaled SAR (W/kg)	Plots #
MHz	Ch																
2510.0	20850	LTE B7	20	23.20	23.05	-0.000	0	Left Touch	FCC #1	QPSK	1	0	1:1	0.083	1.035	0.086	
2510.0	20850	LTE B7	20	22.20	21.30	-0.150	1	Left Touch	FCC #1	QPSK	50	0	1:1	0.074	1.230	0.091	
2510.0	20850	LTE B7	20	23.20	23.05	0.120	0	Right Touch	FCC #1	QPSK	1	0	1:1	0.157	1.035	0.162	A8
2510.0	20850	LTE B7	20	22.20	21.30	0.040	1	Right Touch	FCC #1	QPSK	50	0	1:1	0.122	1.230	0.150	
2510.0	20850	LTE B7	20	23.20	23.05	0.060	0	Left Tilt	FCC #1	QPSK	1	0	1:1	0.057	1.035	0.059	
2510.0	20850	LTE B7	20	22.20	21.30	0.080	1	Left Tilt	FCC #1	QPSK	50	0	1:1	0.039	1.230	0.048	
2510.0	20850	LTE B7	20	23.20	23.05	-0.070	0	Right Tilt	FCC #1	QPSK	1	0	1:1	0.029	1.035	0.030	
2510.0	20850	LTE B7	20	22.20	21.30	-0.050	1	Right Tilt	FCC #1	QPSK	50	0	1:1	0.026	1.230	0.032	
2510.0	20850	LTE B7	20	23.20	23.05	-0.030	0	Right Touch	FCC #1	QPSK	1	0	1:1	0.148	1.035	0.153	
ANSI / IEEE C95.1-2005- SAFETY LIMIT Spatial Peak Uncontrolled Exposure/General Population Exposure										Head 1.6 W/kg (mW/g) averaged over 1 gram							

Note : Blue entries represent were tested with sim2 on the worst case sim1 tests.

Table 12.10 DTS Head SAR

MEASUREMENT RESULTS																
FREQUENCY		Mode	Maximum Allowed Power [dBm]	Conducted Power [dBm]	Drift Power [dB]	Phantom Position	Device Serial Number	Peak SAR of Area Scan	Data Rate [Mbps]	Duty Cycle	1g SAR (W/kg)	Scaling Factor	Scaling Factor (Duty Cycle)	1g Scaled SAR (W/kg)	Plots #	
MHz	Ch															
2437	6	802.11b	15.00	14.46	0.080	Left Touch	FCC #1	0.265	1	99.2	0.288	1.132	1.008	0.329	A9	
2437	6	802.11b	15.00	14.46	0.180	Right Touch	FCC #1	0.0792	1	99.2	0.084	1.132	1.008	0.096		
2437	6	802.11b	15.00	14.46	-	Left Tilt	FCC #1	0.157	1	99.2	-	1.132	-	-		
2437	6	802.11b	15.00	14.46	-	Right Tilt	FCC #1	0.0612	1	99.2	-	1.132	-	-		
ANSI / IEEE C95.1-2005- SAFETY LIMIT Spatial Peak Uncontrolled Exposure/General Population Exposure										Head 1.6 W/kg (mW/g) averaged over 1 gram						

Note : Blue entries Additional required in order satisfying FCC simultaneous transmission limit criteria.

12.2 Standalone Body-Worn SAR Worn SAR Results

Table 12.11 GSM/PCS/GPRS/WCDMA Body-Worn SAR

MEASUREMENT RESULTS														
FREQUENCY		Mode/ Band	Service	Maximum Allowed Power [dBm]	Conducted Power [dBm]	Drift Power [dB]	Spacing [Side]	Device Serial Number	# of Time Slots	Duty Cycle	1g SAR (W/kg)	Scaling Factor	1g Scaled SAR (W/kg)	Plots #
MHz	Ch													
836.6	190	GSM850	GSM	33.70	33.60	0.010	10 mm [Rear]	FCC #1	1	1:8.3	0.452	1.023	0.462	A10
836.6	190	GSM850	GPRS	27.70	27.60	0.050	10 mm [Rear]	FCC #1	4	1:2.075	0.500	1.023	0.512	A11
1880.0	661	PCS1900	PCS	31.20	30.60	0.120	10 mm [Rear]	FCC #1	1	1:8.3	0.298	1.148	0.342	A12
1880.0	661	PCS1900	GPRS	26.20	26.00	0.020	10 mm [Rear]	FCC #1	3	1:2.77	0.459	1.047	0.481	A13
836.6	4183	WCDMA 850	RMC	24.20	24.10	0.060	10 mm [Rear]	FCC #1	N/A	1:1	0.605	1.023	0.619	A14
1880.0	9400	WCDMA 1900	RMC	23.70	23.70	0.060	10 mm [Rear]	FCC #1	N/A	1:1	0.639	1.000	0.639	A15
ANSI / IEEE C95.1-2005- SAFETY LIMIT Spatial Peak Uncontrolled Exposure/General Population Exposure									Body 1.6 W/kg (mW/g) averaged over 1 gram					

Table 12.12 LTE Body-Worn SAR

MEASUREMENT RESULTS																	
FREQUENCY		Mode/ Band	BW [MHz]	Max Allowed Power [dBm]	Cond. PWR [dBm]	Drift Power [dB]	MPR	Position	Device Serial Number	Mod.	RB Size	RB Offs.	Duty Cycle	1g SAR (W/kg)	Scaling Factor	1g Scaled SAR (W/kg)	Plots #
MHz	Ch																
709.0	23780	LTE B17	10	23.70	23.60	0.040	0	10 mm [Rear]	FCC #1	QPSK	1	49	1:1	0.505	1.023	0.517	A16
709.0	23780	LTE B17	10	22.70	22.37	-0.000	1	10 mm [Rear]	FCC #1	QPSK	25	25	1:1	0.379	1.079	0.409	
844.0	20600	LTE B5	10	23.20	23.10	-0.080	0	10 mm [Rear]	FCC #1	QPSK	1	49	1:1	0.551	1.023	0.564	A17
844.0	20600	LTE B5	10	22.20	21.98	0.050	1	10 mm [Rear]	FCC #1	QPSK	25	25	1:1	0.356	1.052	0.375	
1720.0	20050	LTE B4	20	23.20	23.00	0.080	0	10 mm [Rear]	FCC #1	QPSK	1	50	1:1	0.705	1.047	0.738	A18
1720.0	20050	LTE B4	20	22.20	21.92	0.010	1	10 mm [Rear]	FCC #1	QPSK	50	0	1:1	0.547	1.067	0.584	
1860.0	18700	LTE B2	20	23.20	23.10	0.030	0	10 mm [Rear]	FCC #1	QPSK	1	0	1:1	0.607	1.023	0.621	A19
1860.0	18700	LTE B2	20	22.20	21.87	0.010	1	10 mm [Rear]	FCC #1	QPSK	50	0	1:1	0.469	1.079	0.506	
2510.0	20850	LTE B7	20	23.20	23.05	-0.030	0	10 mm [Rear]	FCC #1	QPSK	1	0	1:1	1.050	1.035	1.087	A20
2535.0	21100	LTE B7	20	23.20	22.99	0.180	0	10 mm [Rear]	FCC #1	QPSK	1	0	1:1	0.995	1.050	1.045	
2560.0	21350	LTE B7	20	23.20	23.00	-0.000	0	10 mm [Rear]	FCC #1	QPSK	1	0	1:1	0.919	1.047	0.962	
2510.0	20850	LTE B7	20	22.20	21.30	-0.060	1	10 mm [Rear]	FCC #1	QPSK	50	0	1:1	0.802	1.230	0.986	
2535.0	21100	LTE B7	20	22.20	21.66	-0.020	1	10 mm [Rear]	FCC #1	QPSK	50	0	1:1	0.732	1.132	0.829	
2560.0	21350	LTE B7	20	22.20	21.68	-0.010	1	10 mm [Rear]	FCC #1	QPSK	50	0	1:1	0.728	1.127	0.820	
2510.0	20850	LTE B7	20	22.20	21.23	-0.080	1	10 mm [Rear]	FCC #1	QPSK	100	0	1:1	0.702	1.250	0.878	
ANSI / IEEE C95.1-2005- SAFETY LIMIT Spatial Peak Uncontrolled Exposure/General Population Exposure									Body 1.6 W/kg (mW/g) averaged over 1 gram								

Table 12.13 DTS Body-Worn SAR

MEASUREMENT RESULTS																
FREQUENCY		Mode	Maximum Allowed Power [dBm]	Conducted Power [dBm]	Drift Power [dB]	Phantom Position	Device Serial Number	Peak SAR of Area Scan	Data Rate [Mbps]	Duty Cycle	1g SAR (W/kg)	Scaling Factor	Scaling Factor (Duty Cycle)	SAR (W/kg)	Plots #	
MHz	Ch															
2437	6	802.11b	15.00	14.46	-0.050	10 mm [Rear]	FCC #1	0.129	1	99.2	0.120	1.132	1.008	0.137	A21	
ANSI / IEEE C95.1-2005- SAFETY LIMIT Spatial Peak Uncontrolled Exposure/General Population Exposure									Body 1.6 W/kg (mW/g) averaged over 1 gram							

12.3 Standalone Wireless router SAR Results

Table 12.14 GPRS Hotspot SAR

MEASUREMENT RESULTS

FREQUENCY		Mode/ Band	Service	Maximum Allowed Power [dBm]	Conducted Power [dBm]	Drift Power [dB]	Spacing [Side]	Device Serial Number	# of Time Slots	Duty Cycle	1g SAR (W/kg)	Scaling Factor	1g Scaled SAR (W/kg)	Plots #
MHz	Ch													
836.6	190	GSM850	GPRS	27.70	27.60	0.100	10 mm [Bottom]	FCC #1	4	1:2.075	0.268	1.023	0.274	
836.6	190	GSM850	GPRS	27.70	27.60	0.090	10 mm [Front]	FCC #1	4	1:2.075	0.299	1.023	0.306	
836.6	190	GSM850	GPRS	33.70	33.60	-0.130	10 mm [Rear]	FCC #1	1	1:8.3	0.457	1.023	0.468	
836.6	190	GSM850	GPRS	30.70	30.40	-0.070	10 mm [Rear]	FCC #1	2	1:4.15	0.449	1.072	0.481	
836.6	190	GSM850	GPRS	29.20	29.10	-0.030	10 mm [Rear]	FCC #1	3	1:2.77	0.435	1.023	0.445	
836.6	190	GSM850	GPRS	27.70	27.60	0.050	10 mm [Rear]	FCC #1	4	1:2.075	0.500	1.023	0.512	A11
836.6	190	GSM850	GPRS	27.70	27.60	0.060	10 mm [Right]	FCC #1	4	1:2.075	0.359	1.023	0.367	
836.6	190	GSM850	GPRS	27.70	27.60	-0.050	10 mm [Left]	FCC #1	4	1:2.075	0.236	1.023	0.241	
836.6	190	GSM850	GPRS	27.70	27.60	0.120	10 mm [Left]	FCC #1	4	1:2.075	0.467	1.023	0.478	
1880.0	661	PCS1900	GPRS	26.20	26.00	0.120	10 mm [Bottom]	FCC #1	3	1:2.77	0.207	1.047	0.217	
1880.0	661	PCS1900	GPRS	26.20	26.00	0.080	10 mm [Front]	FCC #1	3	1:2.77	0.332	1.047	0.348	
1880.0	661	PCS1900	GPRS	31.20	30.60	0.170	10 mm [Rear]	FCC #1	1	1:8.3	0.353	1.148	0.405	
1880.0	661	PCS1900	GPRS	27.70	27.60	0.120	10 mm [Rear]	FCC #1	2	1:4.15	0.325	1.023	0.332	
1880.0	661	PCS1900	GPRS	26.20	26.00	0.020	10 mm [Rear]	FCC #1	3	1:2.77	0.459	1.047	0.481	A13
1880.0	661	PCS1900	GPRS	24.70	24.60	-0.140	10 mm [Rear]	FCC #1	4	1:2.075	0.297	1.023	0.304	
1880.0	661	PCS1900	GPRS	26.20	26.00	0.150	10 mm [Right]	FCC #1	3	1:2.77	0.117	1.047	0.122	
1880.0	661	PCS1900	GPRS	26.20	26.00	0.060	10 mm [Left]	FCC #1	3	1:2.77	0.329	1.047	0.344	
1880.0	661	GSM850	GPRS	26.20	26.00	0.110	10 mm [Rear]	FCC #1	3	1:2.77	0.441	1.047	0.462	
ANSI / IEEE C95.1-2005- SAFETY LIMIT Spatial Peak Uncontrolled Exposure/General Population Exposure								Body 1.6 W/kg (mW/g) averaged over 1 gram						

Note : Blue entries represent were tested with sim2 on the worst case sim1 tests.

Table 12.15 WCDMA Hotspot SAR

MEASUREMENT RESULTS														
FREQUENCY		Mode/ Band	Service	Maximum Allowed Power [dBm]	Conducted Power [dBm]	Drift Power [dB]	Spacing [Side]	Device Serial Number	# of Time Slots	Duty Cycle	1g SAR (W/kg)	Scaling Factor	1g Scaled SAR (W/kg)	Plots #
MHz	Ch													
836.6	4183	WCDMA 850	RMC	24.20	24.10	0.120	10 mm [Bottom]	FCC #1	N/A	1:1	0.312	1.023	0.319	
836.6	4183	WCDMA 850	RMC	24.20	24.10	-0.020	10 mm [Front]	FCC #1	N/A	1:1	0.365	1.023	0.373	
836.6	4183	WCDMA 850	RMC	24.20	24.10	0.060	10 mm [Rear]	FCC #1	N/A	1:1	0.605	1.023	0.619	A14
836.6	4183	WCDMA 850	RMC	24.20	24.10	0.030	10 mm [Right]	FCC #1	N/A	1:1	0.424	1.023	0.434	
836.6	4183	WCDMA 850	RMC	24.20	24.10	-0.020	10 mm [Left]	FCC #1	N/A	1:1	0.294	1.023	0.301	
836.6	4183	WCDMA 850	RMC	24.20	24.10	0.100	10 mm [Rear]	FCC #1	N/A	1:1	0.529	1.023	0.541	
1880.0	9400	WCDMA 1900	RMC	23.70	23.70	0.170	10 mm [Bottom]	FCC #1	N/A	1:1	0.325	1.000	0.325	
1880.0	9400	WCDMA 1900	RMC	23.70	23.70	0.010	10 mm [Front]	FCC #1	N/A	1:1	0.568	1.000	0.568	
1880.0	9400	WCDMA 1900	RMC	23.70	23.70	0.060	10 mm [Rear]	FCC #1	N/A	1:1	0.639	1.000	0.639	A15
1880.0	9400	WCDMA 1900	RMC	23.70	23.70	0.100	10 mm [Right]	FCC #1	N/A	1:1	0.177	1.000	0.177	
1880.0	9400	WCDMA 1900	RMC	23.70	23.70	0.120	10 mm [Left]	FCC #1	N/A	1:1	0.464	1.000	0.464	
1880.0	9400	WCDMA 1900	RMC	23.70	23.70	0.070	10 mm [Rear]	FCC #1	N/A	1:1	0.638	1.000	0.638	
ANSI / IEEE C95.1-2005- SAFETY LIMIT Spatial Peak Uncontrolled Exposure/General Population Exposure									Body 1.6 W/kg (mW/g) averaged over 1 gram					

Note : Blue entries represent were tested with sim2 on the worst case sim1 tests.

Table 12.16 LTE Band 17 Hotspot SAR

MEASUREMENT RESULTS																	
FREQUENCY		Mode/ Band	BW [MHz]	Max Allowed Power [dBm]	Cond. PWR [dBm]	Drift Power [dB]	MPR	Position	Device Serial Number	Mod.	RB Size	RB Offs.	Duty Cycle	1g SAR (W/kg)	Scaling Factor	1g Scaled SAR (W/kg)	Plots #
MHz	Ch																
709.0	23780	LTE B17	10	23.7	23.60	-0.060	0	10 mm [Bot.]	FCC #1	QPSK	1	49	1:1	0.0984	1.023	0.101	
709.0	23780	LTE B17	10	22.7	22.37	-0.030	1	10 mm [Bot.]	FCC #1	QPSK	25	25	1:1	0.0738	1.079	0.080	
709.0	23780	LTE B17	10	23.7	23.60	0.000	0	10 mm [Front]	FCC #1	QPSK	1	49	1:1	0.308	1.023	0.315	
709.0	23780	LTE B17	10	22.7	22.37	0.010	1	10 mm [Front]	FCC #1	QPSK	25	25	1:1	0.234	1.079	0.252	
709.0	23780	LTE B17	10	23.7	23.60	0.040	0	10 mm [Rear]	FCC #1	QPSK	1	49	1:1	0.505	1.023	0.517	A16
709.0	23780	LTE B17	10	22.7	22.37	-0.000	1	10 mm [Rear]	FCC #1	QPSK	25	25	1:1	0.379	1.079	0.409	
709.0	23780	LTE B17	10	23.7	23.60	0.040	0	10 mm [Right]	FCC #1	QPSK	1	49	1:1	0.350	1.023	0.358	
709.0	23780	LTE B17	10	22.7	22.37	-0.010	1	10 mm [Right]	FCC #1	QPSK	25	25	1:1	0.275	1.079	0.297	
709.0	23780	LTE B17	10	23.7	23.60	0.110	0	10 mm [Left]	FCC #1	QPSK	1	49	1:1	0.239	1.023	0.244	
709.0	23780	LTE B17	10	22.7	22.37	0.020	1	10 mm [Left]	FCC #1	QPSK	25	25	1:1	0.172	1.079	0.186	
709.0	23780	LTE B17	10	23.7	23.60	0.100	0	10 mm [Rear]	FCC #1	QPSK	1	49	1:1	0.480	1.023	0.491	
ANSI / IEEE C95.1-2005- SAFETY LIMIT Spatial Peak Uncontrolled Exposure/General Population Exposure									Body 1.6 W/kg (mW/g) averaged over 1 gram								

Note : Blue entries represent were tested with sim2 on the worst case sim1 tests.

Table 12.17 LTE Band 5 (Cell) Hotspot SAR

MEASUREMENT RESULTS																	
FREQUENCY		Mode/ Band	BW [MHz]	Max Allowed Power [dBm]	Cond. PWR [dBm]	Drift Power [dB]	MPR	Position	Device Serial Number	Mod.	RB Size	RB Offs.	Duty Cycle	1g SAR (W/kg)	Scaling Factor	1g Scaled SAR (W/kg)	Plots #
MHz	Ch																
844.0	20600	LTE B5	10	23.20	23.10	0.110	0	10 mm [Bot.]	FCC #1	QPSK	1	49	1:1	0.245	1.023	0.251	
844.0	20600	LTE B5	10	22.20	21.98	0.140	1	10 mm [Bot.]	FCC #1	QPSK	25	25	1:1	0.182	1.052	0.191	
844.0	20600	LTE B5	10	23.20	23.10	-0.120	0	10 mm [Front]	FCC #1	QPSK	1	49	1:1	0.315	1.023	0.322	
844.0	20600	LTE B5	10	22.20	21.98	0.150	1	10 mm [Front]	FCC #1	QPSK	25	25	1:1	0.246	1.052	0.259	
844.0	20600	LTE B5	10	23.20	23.10	-0.080	0	10 mm [Rear]	FCC #1	QPSK	1	49	1:1	0.551	1.023	0.564	A17
844.0	20600	LTE B5	10	22.20	21.98	0.050	1	10 mm [Rear]	FCC #1	QPSK	25	25	1:1	0.356	1.052	0.375	
844.0	20600	LTE B5	10	23.20	23.10	-0.090	0	10 mm [Right]	FCC #1	QPSK	1	49	1:1	0.471	1.023	0.482	
844.0	20600	LTE B5	10	22.20	21.98	0.050	1	10 mm [Right]	FCC #1	QPSK	25	25	1:1	0.343	1.052	0.361	
844.0	20600	LTE B5	10	23.20	23.10	0.030	0	10 mm [Left]	FCC #1	QPSK	1	49	1:1	0.254	1.023	0.260	
844.0	20600	LTE B5	10	22.20	21.98	0.100	1	10 mm [Left]	FCC #1	QPSK	25	25	1:1	0.212	1.052	0.223	
844.0	20600	LTE B5	10	23.20	23.10	0.090	0	10 mm [Rear]	FCC #1	QPSK	1	49	1:1	0.477	1.023	0.488	
ANSI / IEEE C95.1-2005- SAFETY LIMIT Spatial Peak Uncontrolled Exposure/General Population Exposure										Body 1.6 W/kg (mW/g) averaged over 1 gram							

Note : Blue entries represent were tested with sim2 on the worst case sim1 tests.

Table 12.18 LTE Band 4(AWS) Hotspot SAR

MEASUREMENT RESULTS																	
FREQUENCY		Mode/ Band	BW [MHz]	Max Allowed Power [dBm]	Cond. PWR [dBm]	Drift Power [dB]	MPR	Position	Device Serial Number	Mod.	RB Size	RB Offs.	Duty Cycle	1g SAR (W/kg)	Scaling Factor	1g Scaled SAR (W/kg)	Plots #
MHz	Ch																
1720.0	20050	LTE B4	20	23.20	23.00	0.120	0	10 mm [Bot.]	FCC #1	QPSK	1	50	1:1	0.456	1.047	0.477	
1720.0	20050	LTE B4	20	22.20	21.92	-0.030	1	10 mm [Bot.]	FCC #1	QPSK	50	0	1:1	0.322	1.067	0.344	
1720.0	20050	LTE B4	20	23.20	23.00	-0.000	0	10 mm [Front]	FCC #1	QPSK	1	50	1:1	0.628	1.047	0.658	
1720.0	20050	LTE B4	20	22.20	21.92	-0.000	1	10 mm [Front]	FCC #1	QPSK	50	0	1:1	0.478	1.067	0.510	
1720.0	20050	LTE B4	20	23.20	23.00	0.080	0	10 mm [Rear]	FCC #1	QPSK	1	50	1:1	0.705	1.047	0.738	A18
1720.0	20050	LTE B4	20	22.20	21.92	0.010	1	10 mm [Rear]	FCC #1	QPSK	50	0	1:1	0.547	1.067	0.584	
1720.0	20050	LTE B4	20	23.20	23.00	-0.010	0	10 mm [Right]	FCC #1	QPSK	1	50	1:1	0.238	1.047	0.249	
1720.0	20050	LTE B4	20	22.20	21.92	0.040	1	10 mm [Right]	FCC #1	QPSK	50	0	1:1	0.184	1.067	0.196	
1720.0	20050	LTE B4	20	23.20	23.00	-0.020	0	10 mm [Left]	FCC #1	QPSK	1	50	1:1	0.622	1.047	0.651	
1720.0	20050	LTE B4	20	22.20	21.92	0.000	1	10 mm [Left]	FCC #1	QPSK	50	0	1:1	0.451	1.067	0.481	
1720.0	20050	LTE B4	20	23.20	23.00	-0.100	0	10 mm [Rear]	FCC #1	QPSK	1	50	1:1	0.690	1.047	0.722	
ANSI / IEEE C95.1-2005- SAFETY LIMIT Spatial Peak Uncontrolled Exposure/General Population Exposure										Body 1.6 W/kg (mW/g) averaged over 1 gram							

Note : Blue entries represent were tested with sim2 on the worst case sim1 tests.

Table 12.19 LTE Band 2 (PCS) Hotspot SAR

MEASUREMENT RESULTS

FREQUENCY		Mode/ Band	BW [MHz]	Max Allowed Power [dBm]	Cond. PWR [dBm]	Drift Power [dB]	MPR	Position	Device Serial Number	Mod.	RB Size	RB Offs.	Duty Cycle	1g SAR (W/kg)	Scaling Factor	1g Scaled SAR (W/kg)	Plots #
MHz	Ch																
1860.0	18700	LTE B2	20	23.20	23.10	0.040	0	10 mm [Bot.]	FCC #1	QPSK	1	0	1:1	0.236	1.023	0.241	
1860.0	18700	LTE B2	20	22.20	21.87	-0.060	1	10 mm [Bot.]	FCC #1	QPSK	50	0	1:1	0.202	1.079	0.218	
1860.0	18700	LTE B2	20	23.20	23.10	0.030	0	10 mm [Front]	FCC #1	QPSK	1	0	1:1	0.568	1.023	0.581	
1860.0	18700	LTE B2	20	22.20	21.87	0.040	1	10 mm [Front]	FCC #1	QPSK	50	0	1:1	0.441	1.079	0.476	
1860.0	18700	LTE B2	20	23.20	23.10	0.030	0	10 mm [Rear]	FCC #1	QPSK	1	0	1:1	0.607	1.023	0.621	A19
1860.0	18700	LTE B2	20	22.20	21.87	0.010	1	10 mm [Rear]	FCC #1	QPSK	50	0	1:1	0.469	1.079	0.506	
1860.0	18700	LTE B2	20	23.20	23.10	0.130	0	10 mm [Right]	FCC #1	QPSK	1	0	1:1	0.183	1.023	0.187	
1860.0	18700	LTE B2	20	22.20	21.87	0.120	1	10 mm [Right]	FCC #1	QPSK	50	0	1:1	0.136	1.079	0.147	
1860.0	18700	LTE B2	20	23.20	23.10	0.090	0	10 mm [Left]	FCC #1	QPSK	1	0	1:1	0.505	1.023	0.517	
1860.0	18700	LTE B2	20	22.20	21.87	0.030	1	10 mm [Left]	FCC #1	QPSK	50	0	1:1	0.385	1.079	0.415	
1860.0	18700	LTE B2	20	23.20	23.10	0.010	0	10 mm [Rear]	FCC #1	QPSK	1	0	1:1	0.588	1.023	0.602	
ANSI / IEEE C95.1-2005- SAFETY LIMIT Spatial Peak Uncontrolled Exposure/General Population Exposure									Body 1.6 W/kg (mW/g) averaged over 1 gram								

Note : Blue entries represent were tested with sim2 on the worst case sim1 tests.

Table 12.20 LTE Band 7 Hotspot SAR

MEASUREMENT RESULTS																	
FREQUENCY		Mode/ Band	BW [MHz]	Max Allowed Power [dBm]	Cond. PWR [dBm]	Drift Power [dB]	MPR	Position	Device Serial Number	Mod.	RB Size	RB Offs.	Duty Cycle	1g SAR (W/kg)	Scaling Factor	1g Scaled SAR (W/kg)	Plots #
MHz	Ch																
2510.0	20850	LTE B7	20	23.20	23.05	0.020	0	10 mm [Bot.]	FCC #1	QPSK	1	0	1:1	0.982	1.035	1.016	
2535.0	21100	LTE B7	20	23.20	22.99	-0.070	0	10 mm [Bot.]	FCC #1	QPSK	1	0	1:1	0.894	1.050	0.939	
2560.0	21350	LTE B7	20	23.20	23.00	0.020	0	10 mm [Bot.]	FCC #1	QPSK	1	0	1:1	0.972	1.047	1.018	
2510.0	20850	LTE B7	20	22.20	21.30	0.010	1	10 mm [Bot.]	FCC #1	QPSK	50	0	1:1	0.768	1.230	0.945	
2535.0	21100	LTE B7	20	22.20	21.66	0.030	1	10 mm [Bot.]	FCC #1	QPSK	50	0	1:1	0.711	1.132	0.805	
2560.0	21350	LTE B7	20	22.20	21.68	-0.060	1	10 mm [Bot.]	FCC #1	QPSK	50	0	1:1	0.696	1.127	0.784	
2510.0	20850	LTE B7	20	22.20	21.23	-0.050	1	10 mm [Rear]	FCC #1	QPSK	100	0	1:1	0.591	1.250	0.739	
2510.0	20850	LTE B7	20	23.20	23.05	-0.080	0	10 mm [Front]	FCC #1	QPSK	1	0	1:1	0.581	1.035	0.601	
2510.0	20850	LTE B7	20	22.20	21.30	0.020	1	10 mm [Front]	FCC #1	QPSK	50	0	1:1	0.454	1.230	0.558	
2510.0	20850	LTE B7	20	23.20	23.05	-0.030	0	10 mm [Rear]	FCC #1	QPSK	1	0	1:1	1.050	1.035	1.087	A20
2535.0	21100	LTE B7	20	23.20	22.99	0.180	0	10 mm [Rear]	FCC #1	QPSK	1	0	1:1	0.995	1.050	1.045	
2560.0	21350	LTE B7	20	23.20	23.00	-0.000	0	10 mm [Rear]	FCC #1	QPSK	1	0	1:1	0.919	1.047	0.962	
2510.0	20850	LTE B7	20	22.20	21.30	-0.060	1	10 mm [Rear]	FCC #1	QPSK	50	0	1:1	0.802	1.230	0.986	
2535.0	21100	LTE B7	20	22.20	21.66	-0.020	1	10 mm [Rear]	FCC #1	QPSK	50	0	1:1	0.732	1.132	0.829	
2560.0	21350	LTE B7	20	22.20	21.68	-0.010	1	10 mm [Rear]	FCC #1	QPSK	50	0	1:1	0.728	1.127	0.820	
2510.0	20850	LTE B7	20	22.20	21.23	-0.080	1	10 mm [Rear]	FCC #1	QPSK	100	0	1:1	0.702	1.250	0.878	
2510.0	20850	LTE B7	20	23.20	23.05	-0.160	0	10 mm [Right]	FCC #1	QPSK	1	0	1:1	0.308	1.035	0.319	
2510.0	20850	LTE B7	20	22.20	21.30	-0.020	1	10 mm [Right]	FCC #1	QPSK	50	0	1:1	0.243	1.230	0.299	
2510.0	20850	LTE B7	20	23.20	23.05	-0.100	0	10 mm [Left]	FCC #1	QPSK	1	0	1:1	0.039	1.035	0.040	
2510.0	20850	LTE B7	20	22.20	21.30	-0.010	1	10 mm [Left]	FCC #1	QPSK	50	0	1:1	0.026	1.230	0.032	
2510.0	20850	LTE B7	20	23.20	23.05	-0.170	0	10 mm [Rear]	FCC #1	QPSK	1	0	1:1	1.020	1.035	1.056	
2510.0	20850	LTE B7	20	23.20	23.05	-0.120	0	10 mm [Rear]	FCC #1	QPSK	1	0	1:1	0.997	1.035	1.032	
ANSI / IEEE C95.1-2005- SAFETY LIMIT Spatial Peak Uncontrolled Exposure/General Population Exposure										Body 1.6 W/kg (mW/g) averaged over 1 gram							

Note : Blue entries represent were tested with sim2 on the worst case sim1 tests.
/ Yellow entries represent variability measurements.

Table 12.21 W-LANHotspotSAR

MEASUREMENT RESULTS																
FREQUENCY		Mode	Maximum Allowed Power [dBm]	Conducted Power [dBm]	Drift Power [dB]	Phantom Position	Device Serial Number	Peak SAR of Area Scan	Data Rate [Mbps]	Duty Cycle	1g SAR (W/kg)	Scaling Factor	Scaling Factor (Duty Cycle)	SAR (W/kg)	Plots #	
MHz	Ch															
2437	6	802.11b	15.00	14.46	-	10 mm [Top]	FCC #1	0.039	1	99.2	-	1.132	1.008	-		
2437	6	802.11b	15.00	14.46	-	10 mm [Front]	FCC #1	0.045	1	99.2	-	1.132	1.008	-		
2437	6	802.11b	15.00	14.46	-0.050	10 mm [Rear]	FCC #1	0.129	1	99.2	0.120	1.132	1.008	0.137	A21	
2437	6	802.11b	15.00	14.46	-	10 mm [Right]	FCC #1	0.038	1	99.2	-	1.132	1.008	-		
ANSI / IEEE C95.1-2005- SAFETY LIMIT Spatial Peak Uncontrolled Exposure/General Population Exposure										Body 1.6 W/kg (mW/g) averaged over 1 gram						

12.4 SAR Test Notes

General Notes:

1. The test data reported are the worst-case SAR values according to test procedures specified in IEEE 1528-2003, and FCC KDB Publication 447498 D01v05r02.
2. Batteries are fully charged at the beginning of the SAR measurements. A standard battery was used for all SAR measurements.
3. Liquid tissue depth was at least 15.0 cm for all frequencies.
4. The manufacturer has confirmed that the device(s) tested have the same physical, mechanical and thermal characteristics and are within operational tolerances expected for production units.
5. SAR results were scaled to the maximum allowed power to demonstrate compliance per FCC KDB Publication 447498 D01v05r02.
6. Device was tested using a fixed spacing for body-worn accessory testing. A separation distance of 10 mm was considered because the manufacturer has determined that there will be body-worn accessories available in the marketplace for users to support this separation distance.
7. Per FCC KDB Publication 648474 D04v01r02, SAR was evaluated without a headset connected to the device. Since the standalone reported SAR was not > 1.2 W/kg, no additional SAR evaluations using a headset cable were performed.
8. During SAR Testing for the Wireless Router conditions per FCC KDB Publication 941225 D06v02, the actual Portable Hotspot operation (with actual simultaneous transmission of a transmitter with WIFI) was not activated (See Section 6.7 for more details).
9. Per FCC KDB 865664 D01v01r03, variability SAR tests were performed when the measured SAR results for a frequency band were greater than 0.8 W/kg. Repeated SAR measurements are highlighted in the tables above for clarity. Please see Section 14 for variability analysis.

GSM Notes:

1. Body-Worn accessory testing is typically associated with voice operations. Therefore, GSM voice was evaluated for body-worn SAR.
2. This device supports GSM VOIP in the head and body-worn configurations; therefore GPRS was additionally evaluated for head and body-worn compliance.
3. Justification for reduced test configurations per KDB Publication 941225 D01v03 and October 2013 TCB Workshop Notes: The source-based frame-averaged output power was evaluated for all GPRS/EDGE slot configurations. The configuration with the highest target frame averaged output power was evaluated for hotspot SAR. When the maximum frame-averaged powers are equivalent across two or more slots (within 0.25 dB), the configuration with the most number of time slots was tested.
4. Per FCC KDB Publication 447498 D01v05r02, if the reported (scaled) SAR measured at the middle channel or highest output power channel for each test configuration is ≤ 0.8 W/kg then testing at the other channels is not required for such test configuration(s). Since the maximum output power variation across the required test channels is not > 1/2 dB, the middle channel was used for testing.

WCDMA(UMTS) Notes:

1. WCDMA (UMTS) mode in was tested under RMC 12.2 kbps with HSPA Inactive per KDB Publication 941225 D01v03. HSPA SAR was not required since the average output power of the HSPA subtests was not more than 0.25 dB higher than the RMC level and SAR was less than 1.2 W/kg.
2. Per FCC KDB Publication 447498 D01v05r02, if the reported (scaled) SAR measured at the middle channel or highest output power channel for each test configuration is ≤ 0.8 W/kg then testing at the other channels is not required for such test configuration(s). When the maximum output power variation across the required test channels is $> \frac{1}{2}$ dB, instead of the middle channel, the highest output power channel was used.

LTE Notes:

1. LTE Considerations: LTE test configurations are determined according to SAR Evaluation Considerations for LTE Devices in FCC KDB Publication 941225 D05v02r03. The general test procedures used for testing can be found in Section 4.1.
2. MPR is permanently implemented for this device by the manufacturer. The specific manufacturer target MPR is indicated alongside the SAR results. MPR is enabled for this device, according to 3GPP TS36. 101 Section 6.2.3 – 6.2.5 under Table 6.2.3-1.
3. Per FCC Guidance, LTE CA SAR was not needed for testing since the data sent by uplink on uplink physical channels does not change between Rel 8 and Rel 10.

BT/WLAN Notes:

1. For held-to-ear and hotspot operations, the initial test position procedures were applied. The test position with the highest extrapolated peak SAR will be used as the initial test position. When reported SAR for the initial test position is ≤ 0.4 W/kg, no additional testing for the remaining test positions was required. Otherwise, SAR is evaluated at the subsequent highest peak SAR positions until the reported SAR result is ≤ 0.8 W/kg or all test positions are measured.
2. Justification for test configurations for WLAN per KDB Publication 248227 D01v02 for 2.4 GHz WIFI single transmission chain operations, the highest measured maximum output power channel for DSSS was selected for SAR measurement. SAR for OFDM modes (2.4 GHz 802.11g/n) was not required due to the maximum allowed powers and the highest reported DSSS SAR. See Section 8.6.5 for more information.
3. Justification for test configurations for WLAN per KDB Publication 248227 D01v02 for 5 GHz WIFI single transmission chain operations, the initial test configuration was selected according to the transmission mode with the highest maximum allowed powers. Other transmission modes were not investigated since the highest reported SAR for initial test configuration adjusted by the ratio of maximum output powers is less than 1.2 W/kg. See Section 8.6.6 for more information.
4. When the maximum reported 1g averaged SAR is ≤ 0.8 W/kg, SAR testing on additional channels was not required. Otherwise, SAR for the next highest output power channel was required until the reported SAR result was ≤ 1.20 W/kg or all test channels were measured.
5. The device was configured to transmit continuously at the required data rate, channel bandwidth and signal modulation, using the highest transmission duty factor supported by the test mode tools. The reported SAR was scaled to the 100% transmission duty factor to determine compliance.
6. The channel and data rate with the highest average output power were evaluated for Bluetooth.

13. FCC MULTI-TX AND ANTENNA SAR CONSIDERATIONS

13.1 Introduction

The following procedures adopted from FCC KDB Publication 447498 D01v05r02 are applicable to handsets with built-in unlicensed transmitters such as 802.11b/g/n and Bluetooth devices which may simultaneously transmit with the licensed transmitter.

13.2 Simultaneous Transmission Procedures

This device contains transmitters that may operate simultaneously. Therefore simultaneous transmission analysis is required. Per FCC KDB 447498 D01v05r02 IV.C.1.iii and IEEE 1528-2013 Section 6.3.4.1.2, simultaneous transmission SAR test exclusion may be applied when the sum of the 1-g SAR for all the simultaneous transmitting antennas in a specific physical test configuration is ≤ 1.6 W/kg. When standalone SAR is not required to be measured, per FCC KDB 447498 D01v05r02 4.3.2 2), the following equation must be used to estimate the standalone 1g SAR for simultaneous transmission assessment involving that transmitter.

$$\text{Estimated SAR} = \frac{\sqrt{f(\text{GHz})}}{7.5} * \frac{(\text{Max Power of channel, mW})}{\text{Min. Separation Distance, mm}}$$

Table 13.1 Estimated SAR

Mode	Frequency	Maximum Allowed Power		Separation Distance (Body)	Estimated SAR (Body)
	[MHz]	[dBm]	[mW]	[mm]	[W/kg]
Bluetooth	2441	7.59	6	10	0.120

Note :Held-to ear configurations are not applicable to Bluetooth operations and therefore were not considered for simultaneous transmission. Per KDB Publication 447498 D01v05, the maximum power of the channel was rounded to the nearest mW before calculation.

13.3 Simultaneous Transmission Capabilities

According to FCC KDB Publication 447498 D01v05r02, transmitters are considered to be transmitting simultaneously when there is overlapping transmission, with the exception of transmissions during network hand-offs with maximum hand-off duration less than 30 seconds. Possible transmission paths for the DUT are shown in Figure 13.1 and are color-coded to indicate communication modes which share the same path. Modes which share the same transmission path cannot transmit simultaneously with one another.



Figure 13.1 Simultaneous Transmission Paths

This device contains multiple transmitters that may operate simultaneously, and therefore requires a simultaneous transmission analysis according to FCC KDB Publication 447498 D01v05r02.

Table 13.2 Simultaneous Transmission Scenarios

No.	Capable TX Configuration	GSM850/1900 Voice	GPRS/EDGE 850/1900	WCDMA 850/1900 Voice	WCDMA 850/1900 data	LTE B2, B4, B5, B7 B17	WIFI 2.4 GHz 802.11b/g/n	Bluetooth 2.4GHz	NFC
1	GSM850/1900 Voice		No	No	No	No	Yes	Yes	Yes
2	GPRS/EDGE 850/1900	No		No	No	No	Yes	Yes	Yes
3	WCDMA 850/1900 Voice	No	No		No	No	Yes	Yes	Yes
4	WCDMA 850/1900 data	No	No	No		No	Yes	Yes	Yes
5	LTE B2, B4, B5, B7 B17	No	No	No	No		Yes	Yes	Yes
6	WIFI 2.4 GHz 802.11b/g/n	Yes	Yes	Yes	Yes	Yes		No	Yes
7	Bluetooth 2.4GHz	Yes	Yes	Yes	Yes	Yes	No		Yes
8	NFC	Yes	Yes	Yes	Yes	Yes	Yes	Yes	

Table 13.3 Simultaneous SAR Cases

No.	Capable Transmit Configuration	Head	Body-Worn Accessory	Wireless Router	Note
1	GSM850/1900 Voice + 2.4 GHz WIFI	Yes	Yes	Yes	
2	WCDMA 850/1900 + 2.4 GHz WIFI	Yes	Yes	Yes	
3	GSM850/1900 GPRS + 2.4 GHz WIFI	Yes *	Yes *	Yes	* Pre-installed VOIP applications are considered.
4	LTE Band 17/5/4/2/7 + 2.4 GHz WIFI	Yes *	Yes *	Yes	* Pre-installed VOIP applications are considered.
5	GSM850/1900 Voice + Bluetooth	N/A	Yes	N/A	
6	WCDMA 850/1900 + Bluetooth	N/A	Yes	N/A	
7	GSM850/1900 GPRS + Bluetooth	N/A	Yes	N/A	* Pre-installed VOIP applications are considered.
8	LTE Band 17/5/4/2/7 + Bluetooth	N/A	Yes	N/A	* Pre-installed VOIP applications are considered.

Notes:

- 2.4 GHz WIFI is supported Hotspot.
- GPRS, WCDMA, LTE is supported Hotspot.
- Bluetooth and WIFI cannot transmit simultaneously since they share the same chip.
- VOIP is supported.

Note:

- When the user utilizes multiple services in UMTS 3G mode it uses multi-Radio Access Bearer or multi-RAB. The power control is based on a physical control channel (Dedicated Physical Control Channel [DPCCH]) and power control will be adjusted to meet the needs of both services. Therefore, the UMTS+WLAN scenario also represents the UMTS Voice/DATA + WLAN Hotspot scenario.
- Per the manufacturer, WIFI Direct is not expected to be used in conjunction with a held-to-ear or body-worn accessory voice call. Therefore, there are no simultaneous transmission scenarios involving WIFI direct beyond that listed in the above table.

13.4 Head SAR Simultaneous Transmission Analysis

Table 13.3 Simultaneous Transmission Scenario for GSM with 2.4 GHz W-LAN (Held to Ear)

Simult TX	Configuration	GSM850 SAR (W/kg)	2.4G W-LAN (802.11b) SAR (W/kg)	Σ SAR (W/kg)	Simult TX	Configuration	PCS1900 SAR (W/kg)	2.4G W-LAN (802.11b) SAR (W/kg)	Σ SAR (W/kg)
Head SAR	Left Touch	0.348	0.329	0.677	Head SAR	Left Touch	0.456	0.329	0.785
	Right Touch	0.339	0.096	0.435		Right Touch	0.250	0.096	0.346
	Left Tilt	0.223	-	0.223		Left Tilt	0.209	-	0.209
	Right Tilt	0.191	-	0.191		Right Tilt	0.203	-	0.203

Table 13.4 Simultaneous Transmission Scenario for GPRS with 2.4 GHz W-LAN (Held to Ear)

Simult TX	Configuration	GPRS 850 SAR (W/kg)	2.4G W-LAN (802.11b) SAR (W/kg)	Σ SAR (W/kg)	Simult TX	Configuration	GPRS 1900 SAR (W/kg)	2.4G W-LAN (802.11b) SAR (W/kg)	Σ SAR (W/kg)
Head SAR	Left Touch	0.429	0.329	0.758	Head SAR	Left Touch	0.512	0.329	0.841
	Right Touch	0.353	0.096	0.449		Right Touch	0.240	0.096	0.336
	Left Tilt	0.223	-	0.223		Left Tilt	0.190	-	0.190
	Right Tilt	0.202	-	0.202		Right Tilt	0.196	-	0.196

Table 13.5 Simultaneous Transmission Scenario for WCDMA with 2.4 GHz W-LAN (Held to Ear)

Simult TX	Configuration	WCDMA 850 SAR (W/kg)	2.4G W-LAN (802.11b) SAR (W/kg)	Σ SAR (W/kg)	Simult TX	Configuration	WCDMA 1900 SAR (W/kg)	2.4G W-LAN (802.11b) SAR (W/kg)	Σ SAR (W/kg)
Head SAR	Left Touch	0.329	0.329	0.658	Head SAR	Left Touch	0.528	0.329	0.857
	Right Touch	0.341	0.096	0.437		Right Touch	0.332	0.096	0.428
	Left Tilt	0.258	-	0.258		Left Tilt	0.251	-	0.251
	Right Tilt	0.211	-	0.211		Right Tilt	0.240	-	0.240

Table 13.6 Simultaneous Transmission Scenario for LTE with 2.4 GHz W-LAN (Held to Ear)

Simult TX	Configuration	LTE Band 17 SAR (W/kg)	2.4G W-LAN (802.11b) SAR (W/kg)	ΣSAR (W/kg)	Simult TX	Configuration	LTE Band 5 SAR (W/kg)	2.4G W-LAN (802.11b) SAR (W/kg)	ΣSAR (W/kg)
Head SAR	Left Touch	0.238	0.329	0.567	Head SAR	Left Touch	0.386	0.329	0.715
	Right Touch	0.267	0.096	0.363		Right Touch	0.369	0.096	0.465
	Left Tilt	0.141	-	0.141		Left Tilt	0.248	-	0.248
	Right Tilt	0.134	-	0.134		Right Tilt	0.243	-	0.243
Simult TX	Configuration	LTE Band 4 SAR (W/kg)	2.4G W-LAN (802.11b) SAR (W/kg)	ΣSAR (W/kg)	Simult TX	Configuration	LTE Band 2 SAR (W/kg)	2.4G W-LAN (802.11b) SAR (W/kg)	ΣSAR (W/kg)
Head SAR	Left Touch	0.735	0.329	1.064	Head SAR	Left Touch	0.506	0.329	0.835
	Right Touch	0.361	0.096	0.457		Right Touch	0.286	0.096	0.382
	Left Tilt	0.449	-	0.449		Left Tilt	0.309	-	0.309
	Right Tilt	0.276	-	0.276		Right Tilt	0.199	-	0.199
Simult TX	Configuration	LTE Band 7 SAR (W/kg)	2.4G W-LAN (802.11b) SAR (W/kg)	ΣSAR (W/kg)					
Head SAR	Left Touch	0.086	0.329	0.415					
	Right Touch	0.162	0.096	0.258					
	Left Tilt	0.059	-	0.059					
	Right Tilt	0.03	-	0.030					

13.5 Body-Worn Simultaneous Transmission Analysis

Table 13.8 Simultaneous Transmission Scenario with 2.4 GHz W-LAN (Body-Worn at 10 mm)

Configuration	Mode	2G/3G SAR (W/kg)	2.4G W-LAN (802.11b) SAR (W/kg)	Σ SAR (W/kg)
Rear Side	GSM 850	0.462	0.137	0.595
Rear Side	GPRS 850	0.512	0.137	0.645
Rear Side	PCS 1900	0.342	0.137	0.475
Rear Side	GPRS 1900	0.481	0.137	0.614
Rear Side	WCDMA 850	0.619	0.137	0.752
Rear Side	WCDMA 1900	0.639	0.137	0.772
Rear Side	LTE Band 17	0.517	0.137	0.650
Rear Side	LTE Band 5	0.564	0.137	0.697
Rear Side	LTE Band 4	0.738	0.137	0.871
Rear Side	LTE Band 2	0.621	0.137	0.754
Rear Side	LTE Band 7	1.087	0.137	1.220

Table 13.9 Simultaneous Transmission Scenario with Bluetooth (Body-Worn at 10 mm)

Configuration	Mode	2G/3G SAR (W/kg)	Bluetooth SAR (W/kg)	Σ SAR (W/kg)
Rear Side	GSM 850	0.462	0.120	0.582
Rear Side	GPRS 850	0.512	0.120	0.632
Rear Side	PCS 1900	0.342	0.120	0.462
Rear Side	GPRS 1900	0.481	0.120	0.601
Rear Side	WCDMA 850	0.619	0.120	0.739
Rear Side	WCDMA 1900	0.639	0.120	0.759
Rear Side	LTE Band 17	0.517	0.120	0.637
Rear Side	LTE Band 5	0.564	0.120	0.684
Rear Side	LTE Band 4	0.738	0.120	0.858
Rear Side	LTE Band 2	0.621	0.120	0.741
Rear Side	LTE Band 7	1.087	0.120	1.207

Note: Bluetooth SAR was not required to be measured per FCC KDB 447498 D01v05r02. Estimated SAR results were used in the above table to determine simultaneous transmission SAR test exclusion.

13.6 Hotspot SAR Simultaneous Transmission Analysis

Per FCC KDB Publication 941225 D06v02, the device edges with antennas more than 2.5 cm from edge are not required to be evaluated for SAR ("").

Table 13.10 Simultaneous Transmission Scenario for GPRS with 2.4GHz W-LAN (Hotspot at 10 mm)

Simult TX	Configuration	GPRS 850 SAR (W/kg)	2.4G W-LAN (802.11b) SAR (W/kg)	Σ SAR (W/kg)	Simult TX	Configuration	GPRS 1900 SAR (W/kg)	2.4G W-LAN (802.11b) SAR (W/kg)	Σ SAR (W/kg)
Body SAR	Top	-	-	-	Body SAR	Top	-	-	-
	Bottom	0.274	-	0.274		Bottom	0.217	-	0.217
	Front	0.306	-	0.306		Front	0.348	-	0.348
	Rear	0.512	0.137	0.649		Rear	0.481	0.137	0.618
	Right	0.367	-	0.367		Right	0.122	-	0.122
	Left	0.241	-	0.241		Left	0.344	-	0.344

Table 13.11 Simultaneous Transmission Scenario for WCDMA with 2.4GHz W-LAN (Hotspot at 10 mm)

Simult TX	Configuration	WCDMA 850 SAR (W/kg)	2.4G W-LAN (802.11b) SAR (W/kg)	Σ SAR (W/kg)	Simult TX	Configuration	WCDMA 1900 SAR (W/kg)	2.4G W-LAN (802.11b) SAR (W/kg)	Σ SAR (W/kg)
Body SAR	Top	-	-	-	Body SAR	Top	-	-	-
	Bottom	0.319	-	0.319		Bottom	0.325	-	0.325
	Front	0.373	-	0.373		Front	0.568	-	0.568
	Rear	0.619	0.137	0.756		Rear	0.639	0.137	0.776
	Right	0.434	-	0.434		Right	0.177	-	0.177
	Left	0.301	-	0.301		Left	0.464	-	0.464

Table 13.12 Simultaneous Transmission Scenario for LTE with 2.4GHz W-LAN (Hotspot at 10 mm)

Simult TX	Configuration	LTE Band 4 SAR (W/kg)	2.4G W-LAN (802.11b) SAR (W/kg)	Σ SAR (W/kg)	Simult TX	Configuration	LTE Band 2 SAR (W/kg)	2.4G W-LAN (802.11b) SAR (W/kg)	Σ SAR (W/kg)
Body SAR	Top	-	-	-	Body SAR	Top	-	-	-
	Bottom	0.101	-	0.101		Bottom	0.251	-	0.251
	Front	0.315	-	0.315		Front	0.322	-	0.322
	Rear	0.517	0.137	0.654		Rear	0.564	0.137	0.701
	Right	0.358	-	0.358		Right	0.482	-	0.482
	Left	0.244	-	0.244		Left	0.260	-	0.260
Simult TX	Configuration	LTE Band 4 SAR (W/kg)	2.4G W-LAN (802.11b) SAR (W/kg)	Σ SAR (W/kg)	Simult TX	Configuration	LTE Band 2 SAR (W/kg)	2.4G W-LAN (802.11b) SAR (W/kg)	Σ SAR (W/kg)
Body SAR	Top	-	-	-	Body SAR	Top	-	-	-
	Bottom	0.477	-	0.477		Bottom	0.241	-	0.241
	Front	0.658	-	0.658		Front	0.581	-	0.581
	Rear	0.738	0.137	0.875		Rear	0.621	0.137	0.758
	Right	0.249	-	0.249		Right	0.187	-	0.187
	Left	0.651	-	0.651		Left	0.517	-	0.517
Simult TX	Configuration	LTE Band 7 SAR (W/kg)	2.4G W-LAN (802.11b) SAR (W/kg)	Σ SAR (W/kg)					
Body SAR	Top	-	-	-					
	Bottom	1.018	-	1.018					
	Front	0.601	-	0.601					
	Rear	1.087	0.137	1.224					
	Right	0.319	-	0.319					
	Left	0.040	-	0.040					

13.7 Simultaneous Transmission Conclusion

The above numerical summed SAR results for all the worst-case simultaneous transmission conditions were below the SAR limit. Therefore, the above analysis is sufficient to determine that simultaneous transmission cases will not exceed the SAR limit and therefore no measured volumetric simultaneous SAR summation is required per FCC KDB Publication 447498 D01v05r02 and IEEE 1528-2013 Section 6.3.4.1.2.

14. SAR MEASUREMENT VARIABILITY

14.1 Measurement Variability

Per FCC KDB Publication 865664 D01v01r03, SAR measurement variability was assessed for each frequency band, which was determined by the SAR probe calibration point and tissue-equivalent medium used for the device measurements. When both head and body tissue-equivalent media were required for SAR measurements in a frequency band, the variability measurement procedures were applied to the tissue medium with the highest measured SAR, using the highest measured SAR configuration for that tissue-equivalent medium. These additional measurements were repeated after the completion of all measurements requiring the same head or body tissue-equivalent medium in a frequency band. The test device was returned to ambient conditions (normal room temperature) with the battery fully charged before it was re-mounted on the device holder for the repeated measurement(s) to minimize any unexpected variations in the repeated results.

SAR Measurement Variability was assessed using the following procedures for each frequency band:

1. When the original highest measured SAR is ≥ 0.80 W/kg, the measurement was repeated once.
2. A second repeated measurement was performed only if the ratio of largest to smallest SAR for the original and first repeated measurements was > 1.20 or when the original or repeated measurement was ≥ 1.45 W/kg (~ 10% from the 1-g SAR limit).
3. A third repeated measurement was performed only if the original, first or second repeated measurement was ≥ 1.5 W/kg and the ratio of largest to smallest SAR for the original, first and second repeated measurements is > 1.20 .
4. Repeated measurements are not required when the original highest measured SAR is < 0.80 W/kg

Table 14.1 Body SAR Measurement Variability Results

Frequency		Mode	Service	# of Time Slots	Spacing [Side]	Measured SAR (1g)	1st Repeated SAR(1g)	Ratio	2nd Repeated SAR(1g)	Ratio	3rd Repeated SAR(1g)	Ratio
MHz	Ch.					(W/kg)	(W/kg)		(W/kg)		(W/kg)	
2510.0	20850	LTE B7	QPSK,1RB, 0 RB Offset	N/A	10 mm [Rear]	1.050	0.997	1.05	N/A	N/A	N/A	N/A
ANSI / IEEE C95.1-2005– SAFETY LIMIT Spatial Peak Uncontrolled Exposure/General Population Exposure							Body 1.6 W/kg (mW/g) averaged over 1 gram					

14.2 Measurement Uncertainty

The measured SAR was < 1.5 W/kg for all frequency bands. Therefore, per KDB Publication 865664D01v01r03, the standard measurement uncertainty analysis per IEEE 1528-2003 was not required.

15. IEEE P1528 –MEASUREMENT UNCERTAINTIES

750 MHz Head (ES3DV3-SN: 3328)

Error Description	Uncertainty value $\pm\%$	Probability Distribution	Divisor	(Ci) 1g	Standard (1g)	vi 2 or Veff
Measurement System						
Probe calibration	± 6.0	Normal	1	1	$\pm 6.0 \%$	∞
Axial isotropy	± 4.7	Rectangular	$\sqrt{3}$	1	$\pm 2.714 \%$	∞
Hemispherical isotropy	± 9.6	Rectangular	$\sqrt{3}$	1	$\pm 5.543 \%$	∞
Boundary Effects	± 0.8	Rectangular	$\sqrt{3}$	1	$\pm 0.462 \%$	∞
Probe Linearity	± 4.7	Rectangular	$\sqrt{3}$	1	$\pm 2.714 \%$	∞
Detection limits	± 0.25	Rectangular	$\sqrt{3}$	1	$\pm 0.144 \%$	∞
Readout Electronics	± 1.0	Normal	1	1	$\pm 1.0 \%$	∞
Response time	± 0.8	Rectangular	$\sqrt{3}$	1	$\pm 0.462 \%$	∞
Integration time	± 2.6	Rectangular	$\sqrt{3}$	1	$\pm 1.501 \%$	∞
RF Ambient Conditions	± 3.0	Rectangular	$\sqrt{3}$	1	$\pm 1.732 \%$	∞
Probe Positioner	± 0.4	Rectangular	$\sqrt{3}$	1	$\pm 0.231 \%$	∞
Probe Positioning	± 2.9	Rectangular	$\sqrt{3}$	1	$\pm 1.674 \%$	∞
Algorithms for Max. SAR Eval.	± 1.0	Rectangular	$\sqrt{3}$	1	$\pm 0.577 \%$	∞
Test Sample Related						
Device Positioning	± 2.9	Normal	1	1	$\pm 2.9 \%$	145
Device Holder	± 3.6	Normal	1	1	$\pm 3.6 \%$	5
Power Drift	± 5.0	Rectangular	$\sqrt{3}$	1	$\pm 2.887 \%$	∞
Physical Parameters						
Phantom Shell	± 4.0	Rectangular	$\sqrt{3}$	1	$\pm 2.309 \%$	∞
Liquid conductivity (Target)	± 5.0	Rectangular	$\sqrt{3}$	0.64	$\pm 2.887 \%$	∞
Liquid conductivity (Meas.)	± 3.8	Normal	1	0.64	$\pm 3.8 \%$	∞
Liquid permittivity (Target)	± 5.0	Rectangular	$\sqrt{3}$	0.6	$\pm 2.887 \%$	∞
Liquid permittivity (Meas.)	± 4.1	Normal	1	0.6	$\pm 4.1 \%$	∞
Combined Standard Uncertainty					$\pm 12.0 \%$	330
Expanded Uncertainty (k=2)					$\pm 24.0 \%$	

The above measurement uncertainties are according to IEEE P1528 (2003)

750 MHz Body (ES3DV3-SN: 3328)

Error Description	Uncertainty value $\pm\%$	Probability Distribution	Divisor	(Ci) 1g	Standard (1g)	vi 2 or Veff
Measurement System						
Probe calibration	± 6.0	Normal	1	1	$\pm 6.0 \%$	∞
Axial isotropy	± 4.7	Rectangular	$\sqrt{3}$	1	$\pm 2.714 \%$	∞
Hemispherical isotropy	± 9.6	Rectangular	$\sqrt{3}$	1	$\pm 5.543 \%$	∞
Boundary Effects	± 0.8	Rectangular	$\sqrt{3}$	1	$\pm 0.462 \%$	∞
Probe Linearity	± 4.7	Rectangular	$\sqrt{3}$	1	$\pm 2.714 \%$	∞
Detection limits	± 0.25	Rectangular	$\sqrt{3}$	1	$\pm 0.144 \%$	∞
Readout Electronics	± 1.0	Normal	1	1	$\pm 1.0 \%$	∞
Response time	± 0.8	Rectangular	$\sqrt{3}$	1	$\pm 0.462 \%$	∞
Integration time	± 2.6	Rectangular	$\sqrt{3}$	1	$\pm 1.501 \%$	∞
RF Ambient Conditions	± 3.0	Rectangular	$\sqrt{3}$	1	$\pm 1.732 \%$	∞
Probe Positioner	± 0.4	Rectangular	$\sqrt{3}$	1	$\pm 0.231 \%$	∞
Probe Positioning	± 2.9	Rectangular	$\sqrt{3}$	1	$\pm 1.674 \%$	∞
Algorithms for Max. SAR Eval.	± 1.0	Rectangular	$\sqrt{3}$	1	$\pm 0.577 \%$	∞
Test Sample Related						
Device Positioning	± 2.9	Normal	1	1	$\pm 2.9 \%$	145
Device Holder	± 3.6	Normal	1	1	$\pm 3.6 \%$	5
Power Drift	± 5.0	Rectangular	$\sqrt{3}$	1	$\pm 2.887 \%$	∞
Physical Parameters						
Phantom Shell	± 4.0	Rectangular	$\sqrt{3}$	1	$\pm 2.309 \%$	∞
Liquid conductivity (Target)	± 5.0	Rectangular	$\sqrt{3}$	0.64	$\pm 2.887 \%$	∞
Liquid conductivity (Meas.)	± 4.0	Normal	1	0.64	$\pm 4.0 \%$	∞
Liquid permittivity (Target)	± 5.0	Rectangular	$\sqrt{3}$	0.6	$\pm 2.887 \%$	∞
Liquid permittivity (Meas.)	± 3.8	Normal	1	0.6	$\pm 3.8 \%$	∞
Combined Standard Uncertainty					$\pm 12.0 \%$	330
Expanded Uncertainty (k=2)					$\pm 24.0 \%$	

The above measurement uncertainties are according to IEEE P1528 (2003)

835 MHz Head(ES3DV3-SN: 3328)

Error Description	Uncertainty value $\pm\%$	Probability Distribution	Divisor	(Ci) 1g	Standard (1g)	vi 2 or Veff
Measurement System						
Probe calibration	± 6.0	Normal	1	1	$\pm 6.0 \%$	∞
Axial isotropy	± 4.7	Rectangular	$\sqrt{3}$	1	$\pm 2.714 \%$	∞
Hemispherical isotropy	± 9.6	Rectangular	$\sqrt{3}$	1	$\pm 5.543 \%$	∞
Boundary Effects	± 0.8	Rectangular	$\sqrt{3}$	1	$\pm 0.462 \%$	∞
Probe Linearity	± 4.7	Rectangular	$\sqrt{3}$	1	$\pm 2.714 \%$	∞
Detection limits	± 0.25	Rectangular	$\sqrt{3}$	1	$\pm 0.144 \%$	∞
Readout Electronics	± 1.0	Normal	1	1	$\pm 1.0 \%$	∞
Response time	± 0.8	Rectangular	$\sqrt{3}$	1	$\pm 0.462 \%$	∞
Integration time	± 2.6	Rectangular	$\sqrt{3}$	1	$\pm 1.501 \%$	∞
RF Ambient Conditions	± 3.0	Rectangular	$\sqrt{3}$	1	$\pm 1.732 \%$	∞
Probe Positioner	± 0.4	Rectangular	$\sqrt{3}$	1	$\pm 0.231 \%$	∞
Probe Positioning	± 2.9	Rectangular	$\sqrt{3}$	1	$\pm 1.674 \%$	∞
Algorithms for Max. SAR Eval.	± 1.0	Rectangular	$\sqrt{3}$	1	$\pm 0.577 \%$	∞
Test Sample Related						
Device Positioning	± 2.9	Normal	1	1	$\pm 2.9 \%$	145
Device Holder	± 3.6	Normal	1	1	$\pm 3.6 \%$	5
Power Drift	± 5.0	Rectangular	$\sqrt{3}$	1	$\pm 2.887 \%$	∞
Physical Parameters						
Phantom Shell	± 4.0	Rectangular	$\sqrt{3}$	1	$\pm 2.309 \%$	∞
Liquid conductivity (Target)	± 5.0	Rectangular	$\sqrt{3}$	0.64	$\pm 2.887 \%$	∞
Liquid conductivity (Meas.)	± 4.1	Normal	1	0.64	$\pm 4.1 \%$	∞
Liquid permittivity (Target)	± 5.0	Rectangular	$\sqrt{3}$	0.6	$\pm 2.887 \%$	∞
Liquid permittivity (Meas.)	± 4.3	Normal	1	0.6	$\pm 4.3 \%$	∞
Combined Standard Uncertainty					$\pm 12.1 \%$	330
Expanded Uncertainty (k=2)					$\pm 24.2 \%$	

The above measurement uncertainties are according to IEEE P1528 (2003)

835 MHz Body(ES3DV3-SN: 3328)

Error Description	Uncertainty value $\pm\%$	Probability Distribution	Divisor	(Ci) 1g	Standard (1g)	vi 2 or Veff
Measurement System						
Probe calibration	± 6.0	Normal	1	1	$\pm 6.0 \%$	∞
Axial isotropy	± 4.7	Rectangular	$\sqrt{3}$	1	$\pm 2.714 \%$	∞
Hemispherical isotropy	± 9.6	Rectangular	$\sqrt{3}$	1	$\pm 5.543 \%$	∞
Boundary Effects	± 0.8	Rectangular	$\sqrt{3}$	1	$\pm 0.462 \%$	∞
Probe Linearity	± 4.7	Rectangular	$\sqrt{3}$	1	$\pm 2.714 \%$	∞
Detection limits	± 0.25	Rectangular	$\sqrt{3}$	1	$\pm 0.144 \%$	∞
Readout Electronics	± 1.0	Normal	1	1	$\pm 1.0 \%$	∞
Response time	± 0.8	Rectangular	$\sqrt{3}$	1	$\pm 0.462 \%$	∞
Integration time	± 2.6	Rectangular	$\sqrt{3}$	1	$\pm 1.501 \%$	∞
RF Ambient Conditions	± 3.0	Rectangular	$\sqrt{3}$	1	$\pm 1.732 \%$	∞
Probe Positioner	± 0.4	Rectangular	$\sqrt{3}$	1	$\pm 0.231 \%$	∞
Probe Positioning	± 2.9	Rectangular	$\sqrt{3}$	1	$\pm 1.674 \%$	∞
Algorithms for Max. SAR Eval.	± 1.0	Rectangular	$\sqrt{3}$	1	$\pm 0.577 \%$	∞
Test Sample Related						
Device Positioning	± 2.9	Normal	1	1	$\pm 2.9 \%$	145
Device Holder	± 3.6	Normal	1	1	$\pm 3.6 \%$	5
Power Drift	± 5.0	Rectangular	$\sqrt{3}$	1	$\pm 2.887 \%$	∞
Physical Parameters						
Phantom Shell	± 4.0	Rectangular	$\sqrt{3}$	1	$\pm 2.309 \%$	∞
Liquid conductivity (Target)	± 5.0	Rectangular	$\sqrt{3}$	0.64	$\pm 2.887 \%$	∞
Liquid conductivity (Meas.)	± 4.0	Normal	1	0.64	$\pm 4.0 \%$	∞
Liquid permittivity (Target)	± 5.0	Rectangular	$\sqrt{3}$	0.6	$\pm 2.887 \%$	∞
Liquid permittivity (Meas.)	± 4.4	Normal	1	0.6	$\pm 4.4 \%$	∞
Combined Standard Uncertainty					$\pm 12.1 \%$	330
Expanded Uncertainty (k=2)					$\pm 24.2 \%$	

The above measurement uncertainties are according to IEEE P1528 (2003)

1800 MHz Head(ES3DV3-SN: 3328)

Error Description	Uncertainty value $\pm\%$	Probability Distribution	Divisor	(Ci) 1g	Standard (1g)	vi 2 or Veff
Measurement System						
Probe calibration	± 6.0	Normal	1	1	$\pm 6.0 \%$	∞
Axial isotropy	± 4.7	Rectangular	$\sqrt{3}$	1	$\pm 2.714 \%$	∞
Hemispherical isotropy	± 9.6	Rectangular	$\sqrt{3}$	1	$\pm 5.543 \%$	∞
Boundary Effects	± 0.8	Rectangular	$\sqrt{3}$	1	$\pm 0.462 \%$	∞
Probe Linearity	± 4.7	Rectangular	$\sqrt{3}$	1	$\pm 2.714 \%$	∞
Detection limits	± 0.25	Rectangular	$\sqrt{3}$	1	$\pm 0.144 \%$	∞
Readout Electronics	± 1.0	Normal	1	1	$\pm 1.0 \%$	∞
Response time	± 0.8	Rectangular	$\sqrt{3}$	1	$\pm 0.462 \%$	∞
Integration time	± 2.6	Rectangular	$\sqrt{3}$	1	$\pm 1.501 \%$	∞
RF Ambient Conditions	± 3.0	Rectangular	$\sqrt{3}$	1	$\pm 1.732 \%$	∞
Probe Positioner	± 0.4	Rectangular	$\sqrt{3}$	1	$\pm 0.231 \%$	∞
Probe Positioning	± 2.9	Rectangular	$\sqrt{3}$	1	$\pm 1.674 \%$	∞
Algorithms for Max. SAR Eval.	± 1.0	Rectangular	$\sqrt{3}$	1	$\pm 0.577 \%$	∞
Test Sample Related						
Device Positioning	± 2.9	Normal	1	1	$\pm 2.9 \%$	145
Device Holder	± 3.6	Normal	1	1	$\pm 3.6 \%$	5
Power Drift	± 5.0	Rectangular	$\sqrt{3}$	1	$\pm 2.887 \%$	∞
Physical Parameters						
Phantom Shell	± 4.0	Rectangular	$\sqrt{3}$	1	$\pm 2.309 \%$	∞
Liquid conductivity (Target)	± 5.0	Rectangular	$\sqrt{3}$	0.64	$\pm 2.887 \%$	∞
Liquid conductivity (Meas.)	± 4.6	Normal	1	0.64	$\pm 4.6 \%$	∞
Liquid permittivity (Target)	± 5.0	Rectangular	$\sqrt{3}$	0.6	$\pm 2.887 \%$	∞
Liquid permittivity (Meas.)	± 4.8	Normal	1	0.6	$\pm 4.8 \%$	∞
Combined Standard Uncertainty					$\pm 12.2 \%$	330
Expanded Uncertainty (k=2)					$\pm 24.4 \%$	

The above measurement uncertainties are according to IEEE P1528 (2003)

1800 MHz Body(ES3DV3-SN: 3328)

Error Description	Uncertainty value $\pm\%$	Probability Distribution	Divisor	(Ci) 1g	Standard (1g)	vi 2 or Veff
Measurement System						
Probe calibration	± 6.0	Normal	1	1	$\pm 6.0 \%$	∞
Axial isotropy	± 4.7	Rectangular	$\sqrt{3}$	1	$\pm 2.714 \%$	∞
Hemispherical isotropy	± 9.6	Rectangular	$\sqrt{3}$	1	$\pm 5.543 \%$	∞
Boundary Effects	± 0.8	Rectangular	$\sqrt{3}$	1	$\pm 0.462 \%$	∞
Probe Linearity	± 4.7	Rectangular	$\sqrt{3}$	1	$\pm 2.714 \%$	∞
Detection limits	± 0.25	Rectangular	$\sqrt{3}$	1	$\pm 0.144 \%$	∞
Readout Electronics	± 1.0	Normal	1	1	$\pm 1.0 \%$	∞
Response time	± 0.8	Rectangular	$\sqrt{3}$	1	$\pm 0.462 \%$	∞
Integration time	± 2.6	Rectangular	$\sqrt{3}$	1	$\pm 1.501 \%$	∞
RF Ambient Conditions	± 3.0	Rectangular	$\sqrt{3}$	1	$\pm 1.732 \%$	∞
Probe Positioner	± 0.4	Rectangular	$\sqrt{3}$	1	$\pm 0.231 \%$	∞
Probe Positioning	± 2.9	Rectangular	$\sqrt{3}$	1	$\pm 1.674 \%$	∞
Algorithms for Max. SAR Eval.	± 1.0	Rectangular	$\sqrt{3}$	1	$\pm 0.577 \%$	∞
Test Sample Related						
Device Positioning	± 2.9	Normal	1	1	$\pm 2.9 \%$	145
Device Holder	± 3.6	Normal	1	1	$\pm 3.6 \%$	5
Power Drift	± 5.0	Rectangular	$\sqrt{3}$	1	$\pm 2.887 \%$	∞
Physical Parameters						
Phantom Shell	± 4.0	Rectangular	$\sqrt{3}$	1	$\pm 2.309 \%$	∞
Liquid conductivity (Target)	± 5.0	Rectangular	$\sqrt{3}$	0.64	$\pm 2.887 \%$	∞
Liquid conductivity (Meas.)	± 4.7	Normal	1	0.64	$\pm 4.7 \%$	∞
Liquid permittivity (Target)	± 5.0	Rectangular	$\sqrt{3}$	0.6	$\pm 2.887 \%$	∞
Liquid permittivity (Meas.)	± 4.8	Normal	1	0.6	$\pm 4.8 \%$	∞
Combined Standard Uncertainty					$\pm 12.3 \%$	330
Expanded Uncertainty (k=2)					$\pm 24.6 \%$	

The above measurement uncertainties are according to IEEE P1528 (2003)

1900 MHz Head(ES3DV3-SN: 3328)

Error Description	Uncertainty value $\pm\%$	Probability Distribution	Divisor	(Ci) 1g	Standard (1g)	vi 2 or Veff
Measurement System						
Probe calibration	± 6.0	Normal	1	1	$\pm 6.0 \%$	∞
Axial isotropy	± 4.7	Rectangular	$\sqrt{3}$	1	$\pm 2.714 \%$	∞
Hemispherical isotropy	± 9.6	Rectangular	$\sqrt{3}$	1	$\pm 5.543 \%$	∞
Boundary Effects	± 0.8	Rectangular	$\sqrt{3}$	1	$\pm 0.462 \%$	∞
Probe Linearity	± 4.7	Rectangular	$\sqrt{3}$	1	$\pm 2.714 \%$	∞
Detection limits	± 0.25	Rectangular	$\sqrt{3}$	1	$\pm 0.144 \%$	∞
Readout Electronics	± 1.0	Normal	1	1	$\pm 1.0 \%$	∞
Response time	± 0.8	Rectangular	$\sqrt{3}$	1	$\pm 0.462 \%$	∞
Integration time	± 2.6	Rectangular	$\sqrt{3}$	1	$\pm 1.501 \%$	∞
RF Ambient Conditions	± 3.0	Rectangular	$\sqrt{3}$	1	$\pm 1.732 \%$	∞
Probe Positioner	± 0.4	Rectangular	$\sqrt{3}$	1	$\pm 0.231 \%$	∞
Probe Positioning	± 2.9	Rectangular	$\sqrt{3}$	1	$\pm 1.674 \%$	∞
Algorithms for Max. SAR Eval.	± 1.0	Rectangular	$\sqrt{3}$	1	$\pm 0.577 \%$	∞
Test Sample Related						
Device Positioning	± 2.9	Normal	1	1	$\pm 2.9 \%$	145
Device Holder	± 3.6	Normal	1	1	$\pm 3.6 \%$	5
Power Drift	± 5.0	Rectangular	$\sqrt{3}$	1	$\pm 2.887 \%$	∞
Physical Parameters						
Phantom Shell	± 4.0	Rectangular	$\sqrt{3}$	1	$\pm 2.309 \%$	∞
Liquid conductivity (Target)	± 5.0	Rectangular	$\sqrt{3}$	0.64	$\pm 2.887 \%$	∞
Liquid conductivity (Meas.)	± 4.0	Normal	1	0.64	$\pm 4.0 \%$	∞
Liquid permittivity (Target)	± 5.0	Rectangular	$\sqrt{3}$	0.6	$\pm 2.887 \%$	∞
Liquid permittivity (Meas.)	± 4.5	Normal	1	0.6	$\pm 4.5 \%$	∞
Combined Standard Uncertainty					$\pm 12.1 \%$	330
Expanded Uncertainty (k=2)					$\pm 24.2 \%$	

The above measurement uncertainties are according to IEEE P1528 (2003)

1900 MHz Body(ES3DV3-SN: 3328)

Error Description	Uncertainty value $\pm\%$	Probability Distribution	Divisor	(Ci) 1g	Standard (1g)	vi 2 or Veff
Measurement System						
Probe calibration	± 6.0	Normal	1	1	$\pm 6.0 \%$	∞
Axial isotropy	± 4.7	Rectangular	$\sqrt{3}$	1	$\pm 2.714 \%$	∞
Hemispherical isotropy	± 9.6	Rectangular	$\sqrt{3}$	1	$\pm 5.543 \%$	∞
Boundary Effects	± 0.8	Rectangular	$\sqrt{3}$	1	$\pm 0.462 \%$	∞
Probe Linearity	± 4.7	Rectangular	$\sqrt{3}$	1	$\pm 2.714 \%$	∞
Detection limits	± 0.25	Rectangular	$\sqrt{3}$	1	$\pm 0.144 \%$	∞
Readout Electronics	± 1.0	Normal	1	1	$\pm 1.0 \%$	∞
Response time	± 0.8	Rectangular	$\sqrt{3}$	1	$\pm 0.462 \%$	∞
Integration time	± 2.6	Rectangular	$\sqrt{3}$	1	$\pm 1.501 \%$	∞
RF Ambient Conditions	± 3.0	Rectangular	$\sqrt{3}$	1	$\pm 1.732 \%$	∞
Probe Positioner	± 0.4	Rectangular	$\sqrt{3}$	1	$\pm 0.231 \%$	∞
Probe Positioning	± 2.9	Rectangular	$\sqrt{3}$	1	$\pm 1.674 \%$	∞
Algorithms for Max. SAR Eval.	± 1.0	Rectangular	$\sqrt{3}$	1	$\pm 0.577 \%$	∞
Test Sample Related						
Device Positioning	± 2.9	Normal	1	1	$\pm 2.9 \%$	145
Device Holder	± 3.6	Normal	1	1	$\pm 3.6 \%$	5
Power Drift	± 5.0	Rectangular	$\sqrt{3}$	1	$\pm 2.887 \%$	∞
Physical Parameters						
Phantom Shell	± 4.0	Rectangular	$\sqrt{3}$	1	$\pm 2.309 \%$	∞
Liquid conductivity (Target)	± 5.0	Rectangular	$\sqrt{3}$	0.64	$\pm 2.887 \%$	∞
Liquid conductivity (Meas.)	± 4.2	Normal	1	0.64	$\pm 4.2 \%$	∞
Liquid permittivity (Target)	± 5.0	Rectangular	$\sqrt{3}$	0.6	$\pm 2.887 \%$	∞
Liquid permittivity (Meas.)	± 4.8	Normal	1	0.6	$\pm 4.8 \%$	∞
Combined Standard Uncertainty					$\pm 12.2 \%$	330
Expanded Uncertainty (k=2)					$\pm 24.4 \%$	

The above measurement uncertainties are according to IEEE P1528 (2003)

2450 MHz Head (ES3DV3-SN: 3328)

Error Description	Uncertainty value $\pm\%$	Probability Distribution	Divisor	(Ci) 1g	Standard (1g)	vi 2 or Veff
Measurement System						
Probe calibration	± 6.0	Normal	1	1	$\pm 6.0 \%$	∞
Axial isotropy	± 4.7	Rectangular	$\sqrt{3}$	1	$\pm 2.714 \%$	∞
Hemispherical isotropy	± 9.6	Rectangular	$\sqrt{3}$	1	$\pm 5.543 \%$	∞
Boundary Effects	± 0.8	Rectangular	$\sqrt{3}$	1	$\pm 0.462 \%$	∞
Probe Linearity	± 4.7	Rectangular	$\sqrt{3}$	1	$\pm 2.714 \%$	∞
Detection limits	± 0.25	Rectangular	$\sqrt{3}$	1	$\pm 0.144 \%$	∞
Readout Electronics	± 1.0	Normal	1	1	$\pm 1.0 \%$	∞
Response time	± 0.8	Rectangular	$\sqrt{3}$	1	$\pm 0.462 \%$	∞
Integration time	± 2.6	Rectangular	$\sqrt{3}$	1	$\pm 1.501 \%$	∞
RF Ambient Conditions	± 3.0	Rectangular	$\sqrt{3}$	1	$\pm 1.732 \%$	∞
Probe Positioner	± 0.4	Rectangular	$\sqrt{3}$	1	$\pm 0.231 \%$	∞
Probe Positioning	± 2.9	Rectangular	$\sqrt{3}$	1	$\pm 1.674 \%$	∞
Algorithms for Max. SAR Eval.	± 1.0	Rectangular	$\sqrt{3}$	1	$\pm 0.577 \%$	∞
Test Sample Related						
Device Positioning	± 2.9	Normal	1	1	$\pm 2.9 \%$	145
Device Holder	± 3.6	Normal	1	1	$\pm 3.6 \%$	5
Power Drift	± 5.0	Rectangular	$\sqrt{3}$	1	$\pm 2.887 \%$	∞
Physical Parameters						
Phantom Shell	± 4.0	Rectangular	$\sqrt{3}$	1	$\pm 2.309 \%$	∞
Liquid conductivity (Target)	± 5.0	Rectangular	$\sqrt{3}$	0.64	$\pm 2.887 \%$	∞
Liquid conductivity (Meas.)	± 4.7	Normal	1	0.64	$\pm 4.7 \%$	∞
Liquid permittivity (Target)	± 5.0	Rectangular	$\sqrt{3}$	0.6	$\pm 2.887 \%$	∞
Liquid permittivity (Meas.)	± 4.8	Normal	1	0.6	$\pm 4.8 \%$	∞
Combined Standard Uncertainty					$\pm 12.3 \%$	330
Expanded Uncertainty (k=2)					$\pm 24.6 \%$	

The above measurement uncertainties are according to IEEE P1528 (2003)

2450 MHz Body (ES3DV3-SN: 3328)

Error Description	Uncertainty value $\pm\%$	Probability Distribution	Divisor	(Ci) 1g	Standard (1g)	vi 2 or Veff
Measurement System						
Probe calibration	± 6.0	Normal	1	1	$\pm 6.0 \%$	∞
Axial isotropy	± 4.7	Rectangular	$\sqrt{3}$	1	$\pm 2.714 \%$	∞
Hemispherical isotropy	± 9.6	Rectangular	$\sqrt{3}$	1	$\pm 5.543 \%$	∞
Boundary Effects	± 0.8	Rectangular	$\sqrt{3}$	1	$\pm 0.462 \%$	∞
Probe Linearity	± 4.7	Rectangular	$\sqrt{3}$	1	$\pm 2.714 \%$	∞
Detection limits	± 0.25	Rectangular	$\sqrt{3}$	1	$\pm 0.144 \%$	∞
Readout Electronics	± 1.0	Normal	1	1	$\pm 1.0 \%$	∞
Response time	± 0.8	Rectangular	$\sqrt{3}$	1	$\pm 0.462 \%$	∞
Integration time	± 2.6	Rectangular	$\sqrt{3}$	1	$\pm 1.501 \%$	∞
RF Ambient Conditions	± 3.0	Rectangular	$\sqrt{3}$	1	$\pm 1.732 \%$	∞
Probe Positioner	± 0.4	Rectangular	$\sqrt{3}$	1	$\pm 0.231 \%$	∞
Probe Positioning	± 2.9	Rectangular	$\sqrt{3}$	1	$\pm 1.674 \%$	∞
Algorithms for Max. SAR Eval.	± 1.0	Rectangular	$\sqrt{3}$	1	$\pm 0.577 \%$	∞
Test Sample Related						
Device Positioning	± 2.9	Normal	1	1	$\pm 2.9 \%$	145
Device Holder	± 3.6	Normal	1	1	$\pm 3.6 \%$	5
Power Drift	± 5.0	Rectangular	$\sqrt{3}$	1	$\pm 2.887 \%$	∞
Physical Parameters						
Phantom Shell	± 4.0	Rectangular	$\sqrt{3}$	1	$\pm 2.309 \%$	∞
Liquid conductivity (Target)	± 5.0	Rectangular	$\sqrt{3}$	0.64	$\pm 2.887 \%$	∞
Liquid conductivity (Meas.)	± 4.7	Normal	1	0.64	$\pm 4.7 \%$	∞
Liquid permittivity (Target)	± 5.0	Rectangular	$\sqrt{3}$	0.6	$\pm 2.887 \%$	∞
Liquid permittivity (Meas.)	± 4.8	Normal	1	0.6	$\pm 4.8 \%$	∞
Combined Standard Uncertainty					$\pm 12.3 \%$	330
Expanded Uncertainty (k=2)					$\pm 24.6 \%$	

The above measurement uncertainties are according to IEEE P1528 (2003)

2600 MHz Head (EX3DV4-SN: 3930)

Error Description	Uncertainty value $\pm\%$	Probability Distribution	Divisor	(Ci) 1g	Standard (1g)	vi 2 or Veff
Measurement System						
Probe calibration	± 6.0	Normal	1	1	$\pm 6.0 \%$	∞
Axial isotropy	± 4.7	Rectangular	$\sqrt{3}$	1	$\pm 2.714 \%$	∞
Hemispherical isotropy	± 9.6	Rectangular	$\sqrt{3}$	1	$\pm 5.543 \%$	∞
Boundary Effects	± 0.8	Rectangular	$\sqrt{3}$	1	$\pm 0.462 \%$	∞
Probe Linearity	± 4.7	Rectangular	$\sqrt{3}$	1	$\pm 2.714 \%$	∞
Detection limits	± 0.25	Rectangular	$\sqrt{3}$	1	$\pm 0.144 \%$	∞
Readout Electronics	± 1.0	Normal	1	1	$\pm 1.0 \%$	∞
Response time	± 0.8	Rectangular	$\sqrt{3}$	1	$\pm 0.462 \%$	∞
Integration time	± 2.6	Rectangular	$\sqrt{3}$	1	$\pm 1.501 \%$	∞
RF Ambient Conditions	± 3.0	Rectangular	$\sqrt{3}$	1	$\pm 1.732 \%$	∞
Probe Positioner	± 0.4	Rectangular	$\sqrt{3}$	1	$\pm 0.231 \%$	∞
Probe Positioning	± 2.9	Rectangular	$\sqrt{3}$	1	$\pm 1.674 \%$	∞
Algorithms for Max. SAR Eval.	± 1.0	Rectangular	$\sqrt{3}$	1	$\pm 0.577 \%$	∞
Test Sample Related						
Device Positioning	± 2.9	Normal	1	1	$\pm 2.9 \%$	145
Device Holder	± 3.6	Normal	1	1	$\pm 3.6 \%$	5
Power Drift	± 5.0	Rectangular	$\sqrt{3}$	1	$\pm 2.887 \%$	∞
Physical Parameters						
Phantom Shell	± 4.0	Rectangular	$\sqrt{3}$	1	$\pm 2.309 \%$	∞
Liquid conductivity (Target)	± 5.0	Rectangular	$\sqrt{3}$	0.64	$\pm 2.887 \%$	∞
Liquid conductivity (Meas.)	± 4.2	Normal	1	0.64	$\pm 4.2 \%$	∞
Liquid permittivity (Target)	± 5.0	Rectangular	$\sqrt{3}$	0.6	$\pm 2.887 \%$	∞
Liquid permittivity (Meas.)	± 4.6	Normal	1	0.6	$\pm 4.6 \%$	∞
Combined Standard Uncertainty					$\pm 12.2 \%$	330
Expanded Uncertainty (k=2)					$\pm 24.4\%$	

The above measurement uncertainties are according to IEEE P1528 (2003)

2600 MHz Body (EX3DV4-SN: 3930)

Error Description	Uncertainty value $\pm\%$	Probability Distribution	Divisor	(Ci) 1g	Standard (1g)	vi 2 or Veff
Measurement System						
Probe calibration	± 6.0	Normal	1	1	$\pm 6.0 \%$	∞
Axial isotropy	± 4.7	Rectangular	$\sqrt{3}$	1	$\pm 2.714 \%$	∞
Hemispherical isotropy	± 9.6	Rectangular	$\sqrt{3}$	1	$\pm 5.543 \%$	∞
Boundary Effects	± 0.8	Rectangular	$\sqrt{3}$	1	$\pm 0.462 \%$	∞
Probe Linearity	± 4.7	Rectangular	$\sqrt{3}$	1	$\pm 2.714 \%$	∞
Detection limits	± 0.25	Rectangular	$\sqrt{3}$	1	$\pm 0.144 \%$	∞
Readout Electronics	± 1.0	Normal	1	1	$\pm 1.0 \%$	∞
Response time	± 0.8	Rectangular	$\sqrt{3}$	1	$\pm 0.462 \%$	∞
Integration time	± 2.6	Rectangular	$\sqrt{3}$	1	$\pm 1.501 \%$	∞
RF Ambient Conditions	± 3.0	Rectangular	$\sqrt{3}$	1	$\pm 1.732 \%$	∞
Probe Positioner	± 0.4	Rectangular	$\sqrt{3}$	1	$\pm 0.231 \%$	∞
Probe Positioning	± 2.9	Rectangular	$\sqrt{3}$	1	$\pm 1.674 \%$	∞
Algorithms for Max. SAR Eval.	± 1.0	Rectangular	$\sqrt{3}$	1	$\pm 0.577 \%$	∞
Test Sample Related						
Device Positioning	± 2.9	Normal	1	1	$\pm 2.9 \%$	145
Device Holder	± 3.6	Normal	1	1	$\pm 3.6 \%$	5
Power Drift	± 5.0	Rectangular	$\sqrt{3}$	1	$\pm 2.887 \%$	∞
Physical Parameters						
Phantom Shell	± 4.0	Rectangular	$\sqrt{3}$	1	$\pm 2.309 \%$	∞
Liquid conductivity (Target)	± 5.0	Rectangular	$\sqrt{3}$	0.64	$\pm 2.887 \%$	∞
Liquid conductivity (Meas.)	± 4.6	Normal	1	0.64	$\pm 4.6 \%$	∞
Liquid permittivity (Target)	± 5.0	Rectangular	$\sqrt{3}$	0.6	$\pm 2.887 \%$	∞
Liquid permittivity (Meas.)	± 4.8	Normal	1	0.6	$\pm 4.8 \%$	∞
Combined Standard Uncertainty					$\pm 12.2 \%$	330
Expanded Uncertainty (k=2)					$\pm 24.4 \%$	

The above measurement uncertainties are according to IEEE P1528 (2003)

16. CONCLUSION

Measurement Conclusion

The SAR measurement indicates that the EUT complies with the RF radiation exposure limits of the FCC. These measurements are taken to simulate the RF effects exposure under the worst-case conditions. Precise laboratory measures were taken to assure repeatability of the tests. The tested device complies with the requirements in respect to all parameters subject to the test. The test results and statements relate only to the item(s) tested.

Please note that the absorption and distribution of electromagnetic energy in the body are every complex phenomena that depend on the mass, shape, and size of the body, the orientation of the body with respect to the field vectors, and the electrical properties of both the body and the environment. Other variables that may play a substantial role impossible biological effect are those that characterize the environment (e.g. ambient temperature, air velocity, relative humidity, and body insulation) and those that characterize the individual (e.g. age, gender, activity level, debilitation, or disease).

Because innumerable factors may interact to determine the specific biological outcome of an exposure to electromagnetic fields, any protection guide shall consider maximal amplification of biological effects as a result of field-body interactions, environmental conditions, and physiological variables.

17. REFERENCES

- [1] Federal Communications Commission, ET Docket 93-62, Guidelines for Evaluating the Environmental Effects of Radiofrequency Radiation, Aug. 1996.
- [2] ANSI/IEEE C95.1-2005, American National Standard safety levels with respect to human exposure to radiofrequency electromagnetic fields, 3kHz to 300GHz, New York: IEEE, 2006.
- [3] ANSI/IEEE C95.1-1992, American National Standard safety levels with respect to human exposure to radiofrequency electromagnetic fields, 3kHz to 300GHz, New York: IEEE, Sept. 1992.
- [4] ANSI/IEEE C95.3-2002, IEEE Recommended Practice for the Measurement of Potentially Hazardous Electromagnetic Fields - RF and Microwave, New York: IEEE, December 2002.
- [5] IEEE Standards Coordinating Committee 39 – Standards Coordinating Committee 34 – IEEE Std. 1528-2003, Recommended Practice for Determining the Peak Spatial-Average Specific Absorption Rate (SAR) in the Human Body Due to Wireless Communications Devices.
- [6] NCRP, National Council on Radiation Protection and Measurements, Biological Effects and Exposure Criteria for Radiofrequency Electromagnetic Fields, NCRP Report No. 86, 1986. Reprinted Feb. 1995.
- [7] T. Schmid, O. Egger, N. Kuster, Automated E-field scanning system for dosimetric assessments, IEEE Transaction on Microwave Theory and Techniques, vol. 44, Jan. 1996, pp. 105-113.
- [8] K. Pokovic, T. Schmid, N. Kuster, Robust setup for precise calibration of E-field probes in tissue simulating liquids at mobile communications frequencies, ICECOM97, Oct. 1997, pp. -124.
- [9] K. Pokovic, T. Schmid, and N. Kuster, E-field Probe with improved isotropy in brain simulating liquids, Proceedings of the ELMAR, Zadar, Croatia, June 23-25, 1996, pp. 172-175.
- [10] Schmid & Partner Engineering AG, Application Note: Data Storage and Evaluation, June 1998, p2.
- [11] V. Hombach, K. Meier, M. Burkhardt, E. Kuhn, N. Kuster, The Dependence of EM Energy Absorption upon Human Modeling at 900 MHz, IEEE Transaction on Microwave Theory and Techniques, vol. 44 no. 10, Oct. 1996, pp. 1865-1873.
- [12] N. Kuster and Q. Balzano, Energy absorption mechanism by biological bodies in the near field of dipole antennas above 300MHz, IEEE Transaction on Vehicular Technology, vol. 41, no. 1, Feb. 1992, pp. 17-23.
- [13] G. Hartsgrrove, A. Kraszewski, A. Surowiec, Simulated Biological Materials for Electromagnetic Radiation Absorption Studies, University of Ottawa, Bioelectromagnetics, Canada: 1987, pp. 29-36.
- [14] Q. Balzano, O. Garay, T. Manning Jr., Electromagnetic Energy Exposure of Simulated Users of Portable Cellular Telephones, IEEE Transactions on Vehicular Technology, vol. 44, no.3, Aug. 1995.
- [15] W. Gander, Computermathematik, Birkhaeuser, Basel, 1992.
- [16] W.H. Press, S.A. Teukolsky, W.T. Vetterling, and B.P. Flannery, Numerical Recipes in C, The Art of Scientific Computing, Second edition, Cambridge University Press, 1992.
- [17] N. Kuster, R. Kastle, T. Schmid, Dosimetric evaluation of mobile communications equipment with known precision, IEEE Transaction on Communications, vol. E80-B, no. 5, May 1997, pp. 645-652.
- [18] CENELEC CLC/SC111B, European Prestandard (prENV 50166-2), Human Exposure to Electromagnetic Fields High-frequency: 10kHz-300GHz, Jan. 1995.
- [19] Prof. Dr. Niels Kuster, ETH, Eidgenössische Technische Hochschule Zürich, Dosimetric Evaluation of the Cellular Phone.
- [20] IEC 62209-1, Human exposure to radio frequency fields from hand-held and body-mounted wireless communication devices - Human models, instrumentation, and procedures - Part 1: Procedure to determine the specific absorption rate (SAR) for hand-held devices used in close proximity to the ear (frequency range of 300MHz to 3 GHz), Feb. 2005.

- [21] Industry Canada RSS-102 Radio Frequency Exposure Compliance of Radiocommunication Apparatus (All Frequency Bands) Issue 4, March 2010.
- [22] Health Canada Safety Code 6 Limits of Human Exposure to Radio Frequency Electromagnetic Fields in the Frequency Range from 3 kHz – 300 GHz, 2009
- [23] FCC SAR Test Procedures for 2G-3G Devices, Mobile Hotspot and UMPC Devices KDB Publications 941225, D01-D07
- [24] SAR Measurement procedures for IEEE 802.11a/b/g KDB Publication 248227 D01v02
- [25] FCC SAR Considerations for Handsets with Multiple Transmitters and Antennas, KDB Publications 648474 D02-D04
- [26] FCC SAR Evaluation Considerations for Laptop, Notebook, Netbook and Tablet Computers, FCC KDB Publication 616217 D04
- [27] FCC SAR Measurement and Reporting Requirements for 100MHz – 6 GHz, KDB Publications 865664 D01-D02
- [28] FCC General RF Exposure Guidance and SAR Procedures for Dongles, KDB Publication 447498, D01-D02
- [29] 615223 D01 802 16e Wi-Max SAR Guidance v01, Nov. 13, 2009
- [30] Anexo à Resolução No. 533, de 10 de September de 2009.
- [31] IEC 62209-2, Human exposure to radio frequency fields from hand-held and body-mounted wireless communication devices - Human models, instrumentation, and procedures - Part 2: Procedure to determine the specific absorption rate (SAR) for wireless communication devices used in close proximity to the human body (frequency range of 30 MHz to 6 GHz), Mar. 2010.