

HAC-RF Emission

Communication System: UID 0, CW; Frequency: 835 MHz; Duty Cycle: 1:1

Phantom section: RF Section

DASY5 Configuration:

- Probe: ER3DV6 - SN2540; ConvF(1, 1, 1); Calibrated: 8/26/2014;
- Sensor-Surface: (Fix Surface)
- Electronics: DAE4 Sn1359; Calibrated: 2/17/2014
- Phantom: HAC Test Arch with AMCC; Type: SD HAC P01 BB
- Measurement SW: DASY52, Version 52.8 (7);SEMCAD X Version 14.6.10 (7164)

Dipole E-Field measurement/835 MHz/Hearing Aid Compatibility Test at 15mm distance

(41x361x1): Interpolated grid: dx=0.5000 mm, dy=0.5000 mm

Device Reference Point: 0, 0, -6.3 mm

Reference Value = 105.9 V/m; Power Drift = -0.29 dB

PMR not calibrated. PMF = 1.000 is applied.

E-field emissions = 112.5 V/m

Near-field category: **M4 (AWF 0 dB)**

PMF scaled E-field

Grid 1 M4 108.5 V/m	Grid 2 M4 112.5 V/m	Grid 3 M4 110.2 V/m
Grid 4 M4 64.25 V/m	Grid 5 M4 64.48 V/m	Grid 6 M4 63.53 V/m
Grid 7 M4 109.3 V/m	Grid 8 M4 111.7 V/m	Grid 9 M4 111.2 V/m

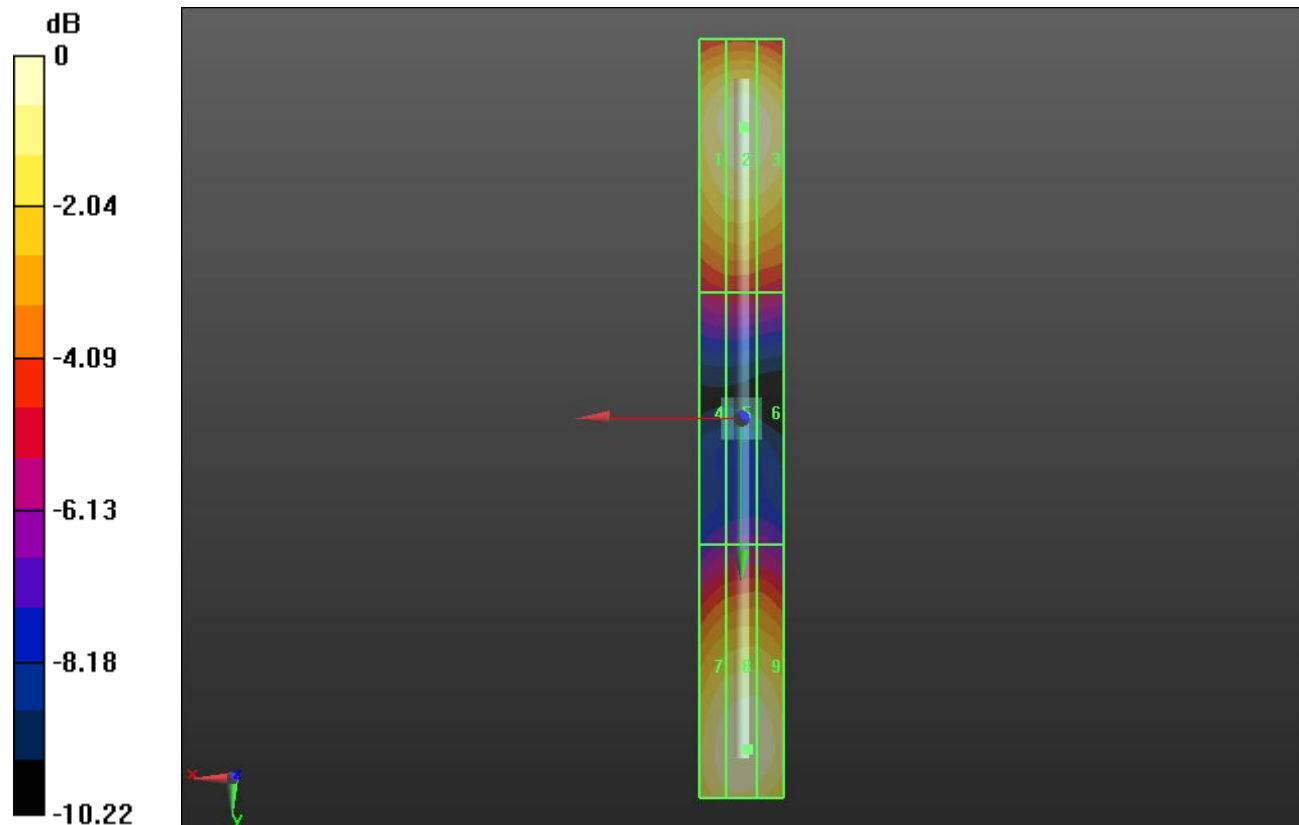

0 dB = 112.5 V/m = 41.02 dBV/m

HAC-RF Emission

Communication System: UID 0, CW; Frequency: 1880 MHz; Duty Cycle: 1:1

Phantom section: RF Section

DASY5 Configuration:

- Probe: ER3DV6 - SN2540; ConvF(1, 1, 1); Calibrated: 8/26/2014;
- Sensor-Surface: (Fix Surface)
- Electronics: DAE4 Sn1359; Calibrated: 2/17/2014
- Phantom: HAC Test Arch with AMCC; Type: SD HAC P01 BB
- Measurement SW: DASY52, Version 52.8 (7);SEMCAD X Version 14.6.10 (7164)

Dipole E-Field measurement/1880 MHz/Hearing Aid Compatibility Test at 15mm distance (41x181x1): Interpolated grid: dx=0.5000 mm, dy=0.5000 mm

Device Reference Point: 0, 0, -6.3 mm

Reference Value = 133.5 V/m; Power Drift = 0.01 dB

PMR not calibrated. PMF = 1.000 is applied.

E-field emissions = 88.42 V/m

Near-field category: **M3 (AWF 0 dB)**

PMF scaled E-field

Grid 1 M3 86.53 V/m	Grid 2 M3 88.42 V/m	Grid 3 M3 87.12 V/m
Grid 4 M3 67.92 V/m	Grid 5 M3 69.97 V/m	Grid 6 M3 69.86 V/m
Grid 7 M3 84.34 V/m	Grid 8 M3 86.70 V/m	Grid 9 M3 86.00 V/m

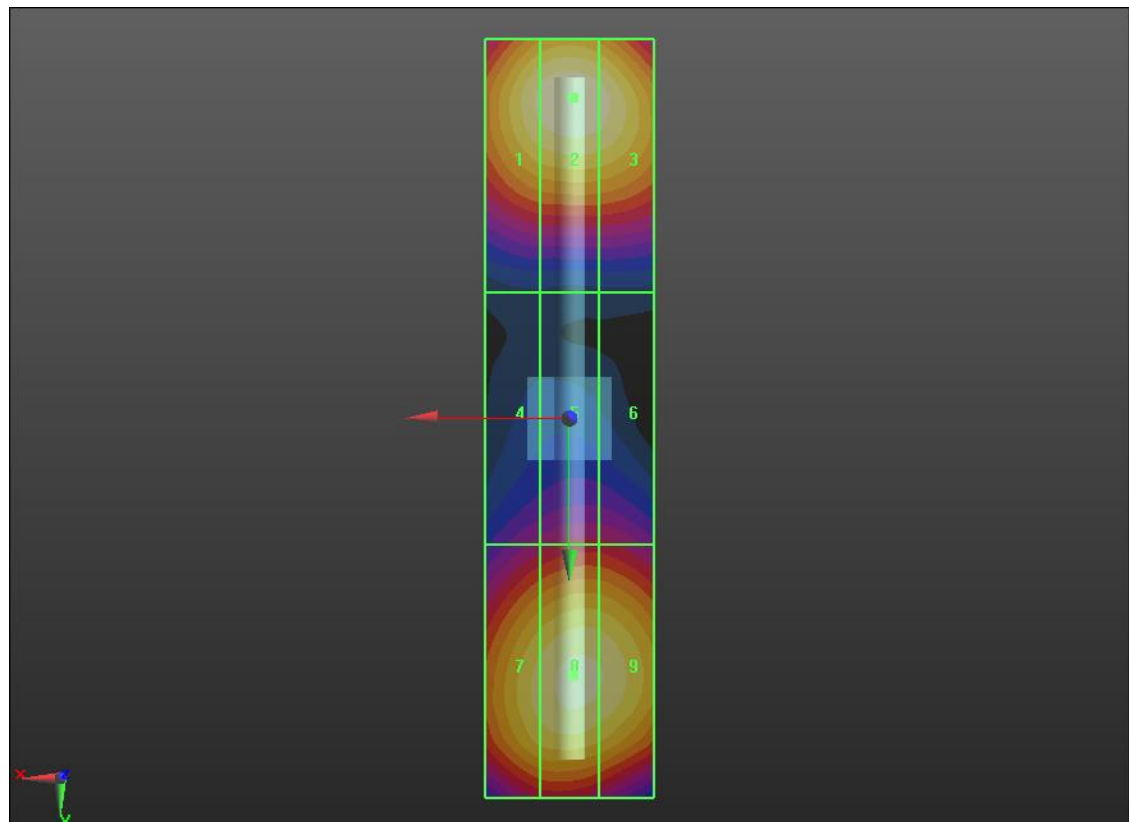
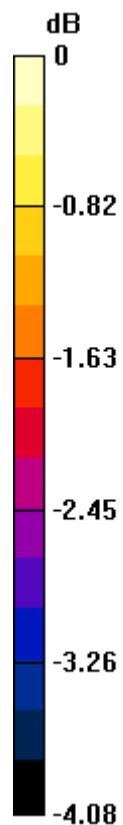

$$0 \text{ dB} = 88.42 \text{ V/m} = 38.93 \text{ dBV/m}$$