



SAR EVALUATION REPORT

Applicant Name:
 LG Electronics U.S.A., Inc.
 111 Sylvan Avenue, North Building
 Englewood Cliffs, NJ 07632
 United States

Date of Testing:
 06/25/20 – 08/05/20
Test Site/Location:
 PCTEST, Columbia, MD, USA
Document Serial No.:
 1M2006040088-01-R1.ZNF

FCC ID: **ZNFG900VM**

APPLICANT: **LG ELECTRONICS U.S.A., INC.**

DUT Type: Portable Handset
Application Type: Class II Permissive Change
FCC Rule Part(s): CFR §2.1093
Model: LM-G900VM
Additional Model(s): LMG900VM, G900VM, LM-G900QM6, LMG900QM6, G900QM6, LM-G902V, LMG902V, G902V
Permissive Change(s): See FCC Change Document
Date of Original Certification: 08/11/2020

Equipment Class	Band & Mode	Tx Frequency	SAR			
			1g Head (W/kg)	1g Body-Worn (W/kg)	1g Hotspot (W/kg)	10g Phablet (W/kg)
PCE	GSM/GPRS/EDGE 850	824.20 - 848.80 MHz	0.19	0.77	0.77	N/A
PCE	GSM/GPRS/EDGE 1900	1850.20 - 1909.80 MHz	< 0.1	0.45	0.98	N/A
PCE	UMTS 850	826.40 - 846.60 MHz	0.21	0.74	0.74	N/A
PCE	UMTS 1900	1852.4 - 1907.6 MHz	0.12	1.13	1.12	3.03
PCE	Cell. CDMA/EVDO	824.70 - 848.31 MHz	0.19	0.74	0.78	N/A
PCE	PCS CDMA/EVDO	1851.25 - 1908.75 MHz	< 0.1	0.93	1.01	2.85
PCE	LTE Band 12	699.7 - 715.3 MHz	0.12	0.33	0.33	N/A
PCE	LTE Band 13	779.5 - 784.5 MHz	0.18	0.62	0.62	N/A
PCE	LTE Band 5 (Cell)	824.7 - 848.3 MHz	0.20	0.69	0.69	N/A
PCE	LTE Band 66 (AWS)	1710.7 - 1779.3 MHz	< 0.1	0.95	0.95	2.86
PCE	LTE Band 4 (AWS)	1710.7 - 1754.3 MHz	N/A	N/A	N/A	N/A
PCE	LTE Band 2 (PCS)	1850.7 - 1909.3 MHz	0.13	1.14	1.07	2.99
CBE	LTE Band 48	3552.5 - 3697.5 MHz	0.27	0.20	0.20	N/A
PCE	NR Band n5 (Cell)	826.5 - 846.5 MHz	0.14	0.62	0.62	N/A
PCE	NR Band n66 (AWS)	1712.5 - 1777.5 MHz	0.20	0.50	1.00	3.14
PCE	NR Band n2 (PCS)	1852.5 - 1907.5 MHz	0.17	0.40	0.83	N/A
DTS	2.4 GHz WLAN	2412 - 2472 MHz	0.61	0.34	0.48	N/A
Nil	U-NII-1	5180 - 5240 MHz	N/A	N/A	0.49	N/A
Nil	U-NII-2A	5260 - 5320 MHz	0.22	0.34	N/A	1.15
Nil	U-NII-2C	5500 - 5720 MHz	0.26	0.29	N/A	0.73
Nil	U-NII-3	5745 - 5825 MHz	0.14	0.24	0.24	N/A
DSS/DTS	Bluetooth	2402 - 2480 MHz	< 0.1	< 0.1	< 0.1	N/A
Simultaneous SAR per KDB 690783 D01v01r03:			1.13	1.59	1.59	3.96

Note: This revised Test Report (1M2006040088-01-R1.ZNF) supersedes and replaces the previously issued test report on the same subject device for the same type of testing as indicated. Please discard or destroy the previously issued test report(s) and dispose of it accordingly.

This wireless portable device has been shown to be capable of compliance for localized specific absorption rate (SAR) for uncontrolled environment/general population exposure limits specified in ANSI/IEEE C95.1-1992 and has been tested in accordance with the measurement procedures specified in Section 1.10 of this report; for North American frequency bands only.

I attest to the accuracy of data. All measurements reported herein were performed by me or were made under my supervision and are correct to the best of my knowledge and belief. I assume full responsibility for the completeness of these measurements and vouch for the qualifications of all persons taking them. Test results reported herein relate only to the item(s) tested.

Randy Ortanez
 President





The SAR Tick is an initiative of the Mobile & Wireless Forum (MWF). While a product may be considered eligible, use of the SAR Tick logo requires an agreement with the MWF. Further details can be obtained by emailing: sartick@mwfai.info.

FCC ID: ZNFG900VM		SAR EVALUATION REPORT		Approved by: Quality Manager
Document S/N: 1M2006040088-01-R1.ZNF	Test Dates: 06/25/20 – 08/05/20	DUT Type: Portable Handset	Page 1 of 159	

TABLE OF CONTENTS



1	DEVICE UNDER TEST	3
2	LTE AND NR INFORMATION	14
3	INTRODUCTION	16
4	DOSIMETRIC ASSESSMENT	17
5	DEFINITION OF REFERENCE POINTS.....	18
6	TEST CONFIGURATION POSITIONS.....	19
7	RF EXPOSURE LIMITS	23
8	FCC MEASUREMENT PROCEDURES.....	24
9	RF CONDUCTED POWERS	31
10	SYSTEM VERIFICATION.....	92
11	SAR DATA SUMMARY	96
12	FCC MULTI-TX AND ANTENNA SAR CONSIDERATIONS.....	126
13	SAR MEASUREMENT VARIABILITY	150
14	ADDITIONAL TESTING PER FCC GUIDANCE	151
15	EQUIPMENT LIST.....	155
16	MEASUREMENT UNCERTAINTIES.....	156
17	CONCLUSION.....	157
18	REFERENCES	158
APPENDIX A:	SAR TEST PLOTS	
APPENDIX B:	SAR DIPOLE VERIFICATION PLOTS	
APPENDIX C:	SAR TISSUE SPECIFICATIONS	
APPENDIX D:	SAR SYSTEM VALIDATION	
APPENDIX E:	DUT ANTENNA DIAGRAM & SAR TEST SETUP PHOTOGRAPHS	
APPENDIX F:	DOWNLINK LTE CA RF CONDUCTED POWERS	
APPENDIX G:	POWER REDUCTION VERIFICATION	
APPENDIX H:	PROBE AND DIPOLE CALIBRATION CERTIFICATES	

FCC ID: ZNFG900VM	 PCTEST <small>Proud to be part of element</small>	SAR EVALUATION REPORT		Approved by: Quality Manager
Document S/N: 1M2006040088-01-R1.ZNF	Test Dates: 06/25/20 – 08/05/20	DUT Type: Portable Handset	Page 2 of 159	

1 DEVICE UNDER TEST

1.1 Device Overview

Band & Mode	Operating Modes	Tx Frequency
GSM/GPRS/EDGE 850	Voice/Data	824.20 - 848.80 MHz
GSM/GPRS/EDGE 1900	Voice/Data	1850.20 - 1909.80 MHz
UMTS 850	Voice/Data	826.40 - 846.60 MHz
UMTS 1900	Voice/Data	1852.4 - 1907.6 MHz
Cell. CDMA/EVDO	Voice/Data	824.70 - 848.31 MHz
PCS CDMA/EVDO	Voice/Data	1851.25 - 1908.75 MHz
LTE Band 12	Voice/Data	699.7 - 715.3 MHz
LTE Band 13	Voice/Data	779.5 - 784.5 MHz
LTE Band 5 (Cell)	Voice/Data	824.7 - 848.3 MHz
LTE Band 66 (AWS)	Voice/Data	1710.7 - 1779.3 MHz
LTE Band 4 (AWS)	Voice/Data	1710.7 - 1754.3 MHz
LTE Band 2 (PCS)	Voice/Data	1850.7 - 1909.3 MHz
LTE Band 48	Voice/Data	3552.5 - 3697.5 MHz
NR Band n5	Data	826.5 - 846.5 MHz
NR Band n66	Data	1712.5 - 1777.5 MHz
NR Band n2	Data	1852.5 - 1907.5 MHz
2.4 GHz WLAN	Voice/Data	2412 - 2462 MHz
U-NII-1	Voice/Data	5180 - 5240 MHz
U-NII-2A	Voice/Data	5260 - 5320 MHz
U-NII-2C	Voice/Data	5500 - 5720 MHz
U-NII-3	Voice/Data	5745 - 5825 MHz
Bluetooth	Data	2402 - 2480 MHz
NFC	Data	13.56 MHz
NR Band n260	Data	37000 - 40000 MHz
NR Band n261	Data	27500 - 28350 MHz
WMC	Data	500 Hz - 4 kHz

FCC ID: ZNFG900VM	 PCTEST Proud to be part of 	SAR EVALUATION REPORT		Approved by: Quality Manager
Document S/N: 1M2006040088-01-R1.ZNF	Test Dates: 06/25/20 – 08/05/20	DUT Type: Portable Handset	Page 3 of 159	

1.2 Time-Averaging Algorithm for RF Exposure Compliance

The equipment under test (EUT) contains:

Qualcomm® SM7250 modem supporting 2G/3G/4G/5G NR WWAN technologies

Qualcomm® SM7250 modem is enabled with Qualcomm® Smart Transmit feature. This feature performs time averaging algorithm in real time to control and manage transmitting power and ensure the time-averaged RF exposure is in compliance with FCC requirements all the time. Refer to Compliance Summary document for detailed description of Qualcomm® Smart Transmit feature (report SN could be found in Section 1.11 – Bibliography).

Note that WLAN operations are not enabled with Smart Transmit.

The Smart Transmit algorithm maintains the time-averaged transmit power, in turn, time-averaged RF exposure of *SAR_design_target*, below the predefined time-averaged power limit (i.e., P_{limit} for sub-6 radio), for each characterized technology and band (see RF Exposure Part 0 Test Report, report SN could be found in Section 1.11 - Bibliography).

Smart Transmit allows the device to transmit at higher power instantaneously, as high as P_{max} , when needed, but enforces power limiting to maintain time-averaged transmit power to P_{limit} . Below table shows P_{limit} EFS settings and maximum tune up output power P_{max} configured for this EUT for various transmit conditions (Device State Index DSI). Note that the device uncertainty for sub-6GHz WWAN is +1.0/-1.0 dB for this EUT.

Exposure Scenario:	Head	Body-Worn	Phablet	Dual Screen 0° or 360°	Dual Screen 180°	Hotspot	Phablet	Maximum Tune-Up Output Power*
Averaging Volume:	1g	1g	10g	1g/10g	1g/10g	1g	10g	
Spacing:	0 mm	10 mm	2, 1, 4 mm	10 mm/ 0 mm	10 mm/ 0 mm	10 mm	0 mm	
DSI:	1			6	7	5	8	
Technology/Band	Antenna	P_{limit}						P_{max}
GSM/GPRS/EDGE 850 MHz	1	27.5		30.7	28.4	27.5		24.8
GSM/GPRS/EDGE 1900 MHz	2	23.0		25.4	25.5	23.0		21.8
UMTS B5	1	26.8		29.3	27.0	26.8		24.5
UMTS B2	2	24.6		23.0	23.0	21.5		24.5
CDMA/EVDO BC0	1	26.6		30.3	28.0	26.6		24.5
CDMA/EVDO BC1	2	24.6		24.0	24.0	21.5		24.5
LTE FDD B12	1	28.9		30.5	27.2	28.9		24.5
LTE FDD B13	1	27.6		30.6	27.3	27.6		24.5
LTE FDD B5	1	26.9		30.8	28.4	26.9		24.5
LTE FDD B66/B4	2	24.6		24.0	24.0	23.0		24.5
LTE FDD B2	2	24.7		24.0	24.0	22.0		24.5
LTE TDD B48	8	20.5		21.8	21.8	20.5		21.5
NR FDD n5	1	27.9		30.8	28.4	27.9		23.8
NR FDD n66	3	23.5		24.7	24.7	23.5		24.5
NR FDD n2	3	23.5		24.9	25.0	23.5		24.5



*Note all P_{limit} EFS and maximum tune up output power P_{max} levels entered in above Table correspond to average power levels after accounting for duty cycle in the case of TDD modulation schemes (for e.g., GSM & LTE TDD).

*Maximum tune up output power P_{max} is used to configure EUT during RF tune up procedure. The maximum allowed output power is equal to maximum Tune up output power + 1.0dB device design uncertainty.

The maximum time-averaged output power (dBm) for any 2G/3G/4G/5G WWAN technology, band, and DSI = minimum of " P_{limit} EFS" and "Maximum tune up output power P_{max} " +1.0/-1.0 dB device uncertainty. SAR values in this report were scaled to this maximum time-averaged output power to determine compliance per KDB Publication 447498 D01v06.

The purpose of this report (Part 1 test) is to demonstrate that the EUT meets FCC SAR limits when transmitting in static transmission scenario at maximum allowable time-averaged power levels.

Measurement Condition: All conducted power and SAR measurements in this report (Part 1 test) were performed by setting Reserve_power_margin (Smart Transmit EFS entry) to 0dB.

FCC ID: ZNFG900VM	 PCTEST Proud to be part of 	SAR EVALUATION REPORT		Approved by: Quality Manager
Document S/N: 1M2006040088-01-R1.ZNF	Test Dates: 06/25/20 – 08/05/20	DUT Type: Portable Handset		Page 4 of 159

1.3 Power Reduction for SAR

This device uses an independent fixed level power reduction mechanism for WLAN operations when 5G NR is active and also during all voice or VoIP held to ear scenarios. Per FCC Guidance, the held-to-ear exposure conditions were evaluated at reduced power according to the head SAR positions described in IEEE 1528-2013. Detailed descriptions of the power reduction mechanism are included in the operational description.

1.4 Dual Display Cover



This device supports Dual Display (DD) Cover, which attaches to the device to provide a secondary display on the inside of the cover. The Dual Display Cover is free rotating from 0 to 360 degrees. Per FCC guidance, the use conditions of 0, 180 and 360 degrees were considered for SAR testing. SAR with the Dual Display Cover was measured for the overall worst case per each exposure condition (head, body-worn accessory, hotspot mode, etc.). Head SAR tests were performed with the accessory cover folded to 0 and 360 degrees to represent typical use conditions. Body-worn, Hotspot, and Phablet SAR tests were performed with accessory cover folded to 0, 180 and 360 degrees. When the output power for dual-display cover in a given exposure condition was higher than the power without the dual display cover, additional tests were performed at the higher output power level.

1.5 Nominal and Maximum Output Power Specifications

This device operates using the following maximum and nominal output power specifications. SAR values were scaled to the maximum allowed power to determine compliance per KDB Publication 447498 D01v06.

1.5.1 2G/3G/4G/5G Output Power



GSM/GPRS/EDGE 850						
Device State Index		Voice (in dBm)	Data - Burst Average GMSK (in dBm)		Data - Burst Average 8-PSK (in dBm)	
		1 TX Slot	1 TX Slots	2 TX Slots	1 TX Slots	2 TX Slots
All DSI	Max allowed power	33.5	33.5	32.0	27.5	27.0
	Nominal	32.5	32.5	31.0	26.5	26.0
GSM/GPRS/EDGE 1900						
Device State Index		Voice (in dBm)	Data - Burst Average GMSK (in dBm)		Data - Burst Average 8-PSK (in dBm)	
		1 TX Slot	1 TX Slots	2 TX Slots	1 TX Slots	2 TX Slots
All DSI	Max allowed power	30.5	30.5	29.0	26.5	26.0
	Nominal	29.5	29.5	28.0	25.5	25.0
UMTS Band 5 (850 MHz)						
Device State Index		Modulated Average Output Power (in dBm)				
		3GPP WCDMA Rel 99	3GPP HSDPA Rel 5	3GPP HSUPA Rel 6		
All DSI	Max allowed power	25.5	25.5	25.5		
	Nominal	24.5	24.5	24.5		
UMTS Band 2 (1900 MHz)						
Device State Index		Modulated Average Output Power (in dBm)				
		3GPP WCDMA Rel 99	3GPP HSDPA Rel 5	3GPP HSUPA Rel 6		
DSI = 1 (Head, Bodyworn, or Phablet Max)	Max allowed power	25.5	25.5	25.5		
	Nominal	24.5	24.5	24.5		
DSI = 6 (Dual Screen 0° or 360°); DSI = 7 (Dual Screen 180°);	Max allowed power	24.0	24.0	24.0		
	Nominal	23.0	23.0	23.0		
DSI = 5 (Hotspot); DSI = 8 (Phablet Reduced)	Max allowed power	22.5	22.5	22.5		
	Nominal	21.5	21.5	21.5		

FCC ID: ZNFG900VM	 PCTEST Proud to be part of 	SAR EVALUATION REPORT		Approved by: Quality Manager
Document S/N: 1M2006040088-01-R1.ZNF	Test Dates: 06/25/20 – 08/05/20	DUT Type: Portable Handset		Page 5 of 159

CDMA BC0 (835 MHz)				
Device State Index		Modulated Average Output Power (in dBm)		
		1x-RTT	EVDO Rev 0	EVDO Rev A
All DSI	Max allowed power	25.5	25.5	25.5
	Nominal	24.5	24.5	24.5
CDMA BC1 (1900 MHz)				
Device State Index		Modulated Average Output Power (in dBm)		
		1x-RTT	EVDO Rev 0	EVDO Rev A
DSI = 1 (Head, Bodyworn, or Phablet Max)	Max allowed power	25.5	25.5	25.5
	Nominal	24.5	24.5	24.5
DSI = 6 (Dual Screen 0° or 360°); DSI = 7 (Dual Screen 180°);	Max allowed power	25.0	25.0	25.0
	Nominal	24.0	24.0	24.0
DSI = 5 (Hotspot); DSI = 8 (Phablet Reduced)	Max allowed power	22.5	22.5	22.5
	Nominal	21.5	21.5	21.5

Mode / Band		Modulated Average Output Power (in dBm)		
		DSI = 1 (Head, Bodyworn, or Phablet Max)	DSI = 6 (Dual Screen 0° or 360°); DSI = 7 (Dual Screen 180°);	DSI = 5 (Hotspot); DSI = 8 (Phablet Reduced)
LTE FDD Band 12	Max allowed power	25.5	25.5	25.5
	Nominal	24.5	24.5	24.5
LTE FDD Band 13	Max allowed power	25.5	25.5	25.5
	Nominal	24.5	24.5	24.5
LTE FDD Band 5	Max allowed power	25.5	25.5	25.5
	Nominal	24.5	24.5	24.5
LTE FDD Band 4	Max allowed power	25.5	25.0	24.0
	Nominal	24.5	24.0	23.0
LTE FDD Band 66	Max allowed power	25.5	25.0	24.0
	Nominal	24.5	24.0	23.0
LTE FDD Band 2	Max allowed power	25.5	25.0	23.0
	Nominal	24.5	24.0	22.0
LTE TDD Band 48	Max allowed power	23.5	24.5	23.5
	Nominal	22.5	23.5	22.5

Mode / Band		Modulated Average Output Power (in dBm)	
		DSI = 1 (Head, Body worn, or Phablet Max) DSI = 5 (Hotspot); DSI = 8 (Phablet Reduced)	DSI = 6 (Dual Screen 0° or 360°); DSI = 7 (Dual Screen 180°);
NR FDD Band n5	Max allowed power	24.8	24.8
	Nominal	23.8	23.8
NR FDD Band n66	Max allowed power	24.5	25.5
	Nominal	23.5	24.5
NR FDD Band n2	Max allowed power	24.5	25.5
	Nominal	23.5	24.5



FCC ID: ZNFG900VM	 PCTEST Proud to be part of 	SAR EVALUATION REPORT		Approved by: Quality Manager
Document S/N: 1M2006040088-01-R1.ZNF	Test Dates: 06/25/20 – 08/05/20	DUT Type: Portable Handset		Page 6 of 159

1.5.2 Maximum Bluetooth and SISO/MIMO WLAN Output Power

Mode	Band	IEEE 802.11 (in dBm)													
		SISO								MIMO					
		Antenna 1/ Antenna 2													
		b		g		n		ac		g (CDD + STBC)		n (CDD+STBC, SDM)		ac (CDD+STBC, SDM)	
Maximum / Nominal Power		Max	Nom.	Max	Nom.	Max	Nom.	Max	Nom.	Max	Nom.	Max	Nom.	Max	Nom.
2.4 GHz WIFI	2.45 GHz	20.5	19.5	19.5	18.5	18.5	17.5	18.5	17.5	22.5	21.5	21.5	20.5	21.5	20.5
				ch. 1: 16.5	15.5	ch. 1: 16.0	15.0	ch. 1: 16.0	15.0	ch. 1: 19.5	18.5	ch. 1: 19.0	18.0	ch. 1: 19.0	18.0
				ch. 2: 16.5	15.5	ch. 2: 16.0	15.0	ch. 2: 16.0	15.0	ch. 2: 19.5	18.5	ch. 2: 19.0	18.0	ch. 2: 19.0	18.0
				ch. 10: 17.0	16.0	ch. 10: 16.0	15.0	ch. 10: 16.0	15.0	ch. 10: 20.0	19.0	ch. 10: 19.0	18.0	ch. 10: 19.0	18.0
				ch. 11: 17.0	16.0	ch. 11: 16.0	15.0	ch. 11: 16.0	15.0	ch. 11: 20.0	19.0	ch. 11: 19.0	18.0	ch. 11: 19.0	18.0

Mode	Band	IEEE 802.11 (in dBm)											
		SISO						MIMO					
		Antenna 1/ Antenna 2											
		a		n		ac		a (CDD + STBC)		n (CDD+STBC, SDM)		ac (CDD+STBC, SDM)	
Maximum / Nominal Power		Max	Nom.	Max	Nom.	Max	Nom.	Max	Nom.	Max	Nom.	Max	Nom.
5 GHz WIFI (20MHz BW)	5200 MHz	17.0	16.0	17.0	16.0	17.0	16.0	20.0	19.0	20.0	19.0	20.0	19.0
		ch. 40: 19.0	18.0	ch. 40: 19.0	18.0	ch. 40: 19.0	18.0	ch. 40: 22.0	21.0	ch. 40: 22.0	21.0	ch. 40: 22.0	21.0
	5300 MHz	17.0	16.0	17.0	16.0	17.0	16.0	20.0	19.0	20.0	19.0	20.0	19.0
		ch. 56: 19.0	18.0	ch. 56: 19.0	18.0	ch. 56: 19.0	18.0	ch. 56: 22.0	21.0	ch. 56: 22.0	21.0	ch. 56: 22.0	21.0
5 GHz WIFI (40MHz BW)	5500 MHz	17.0	16.0	17.0	16.0	17.0	16.0	20.0	19.0	20.0	19.0	20.0	19.0
	5800 MHz	19.0	18.0	19.0	18.0	19.0	18.0	22.0	21.0	22.0	21.0	22.0	21.0
5 GHz WIFI (80MHz BW)	5200 MHz	ch. 149: 17.0	16.0	ch. 149: 17.0	16.0	ch. 149: 17.0	16.0	ch. 149: 20.0	19.0	ch. 149: 20.0	19.0	ch. 149: 20.0	19.0
		ch. 153: 17.0	16.0	ch. 153: 17.0	16.0	ch. 153: 17.0	16.0	ch. 153: 20.0	19.0	ch. 153: 20.0	19.0	ch. 153: 20.0	19.0
	5300 MHz												
	5500 MHz												
5 GHz WIFI (40MHz BW)	5200 MHz			16.0	15.0	16.0	15.0			19.0	18.0	19.0	18.0
	5300 MHz			16.0	15.0	16.0	15.0			19.0	18.0	19.0	18.0
	5500 MHz			16.0	15.0	16.0	15.0			19.0	18.0	19.0	18.0
	5800 MHz			16.0	15.0	16.0	15.0			19.0	18.0	19.0	18.0
5 GHz WIFI (80MHz BW)	5200 MHz					14.0	13.0					17.0	16.0
	5300 MHz					14.0	13.0					17.0	16.0
	5500 MHz					14.0	13.0					17.0	16.0
	5800 MHz					14.0	13.0					17.0	16.0

Mode / Band		Modulated Average (dBm)
Bluetooth	Maximum	11.5
	Nominal	10.5
Bluetooth LE	Maximum	5.0
	Nominal	4.0

FCC ID: ZNFG900VM	 PCTEST Proud to be part of 	SAR EVALUATION REPORT		Approved by: Quality Manager
Document S/N: 1M2006040088-01-R1.ZNF	Test Dates: 06/25/20 – 08/05/20	DUT Type: Portable Handset		Page 7 of 159



1.5.3 Reduced SISO/MIMO WLAN Output Power

The below tables are applicable in the following conditions:

- Head Conditions
- Simultaneous conditions with 2.4 GHz WLAN and 5 GHz WLAN
- Simultaneous conditions with EN-DC and 2.4 GHz WLAN and/or 5 GHz WLAN

Mode	Band	IEEE 802.11 (in dBm)													
		SISO								MIMO					
		Antenna 1/ Antenna 2													
		b		g		n		ac		g (CDD + STBC)		n (CDD+STBC, SDM)		ac (CDD+STBC, SDM)	
Maximum / Nominal Power		Max	Nom.	Max	Nom.	Max	Nom.	Max	Nom.	Max	Nom.	Max	Nom.	Max	Nom.
2.4 GHz WIFI	2.45 GHz	15.0	14.0	15.0	14.0	15.0	14.0	15.0	14.0	18.0	17.0	18.0	17.0	18.0	17.0

Mode	Band	IEEE 802.11 (in dBm)											
		SISO						MIMO					
		Antenna 1/ Antenna 2											
		a		n		ac		a (CDD + STBC)		n (CDD+STBC, SDM)		ac (CDD+STBC, SDM)	
Maximum / Nominal Power		Max	Nom.	Max	Nom.	Max	Nom.	Max	Nom.	Max	Nom.	Max	Nom.
5 GHz WIFI (20MHz BW)	5200 MHz	16.0	15.0	16.0	15.0	16.0	15.0	19.0	18.0	19.0	18.0	19.0	18.0
	5300 MHz	16.0	15.0	16.0	15.0	16.0	15.0	19.0	18.0	19.0	18.0	19.0	18.0
	5500 MHz	16.0	15.0	16.0	15.0	16.0	15.0	19.0	18.0	19.0	18.0	19.0	18.0
	5800 MHz	16.0	15.0	16.0	15.0	16.0	15.0	19.0	18.0	19.0	18.0	19.0	18.0
5 GHz WIFI (40MHz BW)	5200 MHz			16.0	15.0	16.0	15.0			19.0	18.0	19.0	18.0
	5300 MHz			16.0	15.0	16.0	15.0			19.0	18.0	19.0	18.0
	5500 MHz			16.0	15.0	16.0	15.0			19.0	18.0	19.0	18.0
	5800 MHz			16.0	15.0	16.0	15.0			19.0	18.0	19.0	18.0
5 GHz WIFI (80MHz BW)	5200 MHz					14.0	13.0					17.0	16.0
	5300 MHz					14.0	13.0					17.0	16.0
	5500 MHz					14.0	13.0					17.0	16.0
	5800 MHz					14.0	13.0					17.0	16.0

FCC ID: ZNFG900VM	 PCTEST Proud to be part of 	SAR EVALUATION REPORT		Approved by: Quality Manager
Document S/N: 1M2006040088-01-R1.ZNF	Test Dates: 06/25/20 – 08/05/20	DUT Type: Portable Handset	Page 8 of 159	

1.6 DUT Antenna Locations

The overall dimensions of this device are > 9 x 5 cm. A diagram showing the location of the device antennas can be found in Appendix E. Since the diagonal dimension of this device is > 160 mm and <200 mm, it is considered a “phablet.”

**Table 1-1
Device Edges/Sides for SAR Testing**

Mode	Back	Front	Top	Bottom	Right	Left
GPRS 850	Yes	Yes	No	Yes	Yes	No
GPRS 1900	Yes	Yes	No	Yes	No	Yes
UMTS 850	Yes	Yes	No	Yes	Yes	No
UMTS 1900	Yes	Yes	No	Yes	No	Yes
Cell. EVDO	Yes	Yes	No	Yes	Yes	No
PCS EVDO	Yes	Yes	No	Yes	No	Yes
LTE Band 12	Yes	Yes	No	Yes	Yes	No
LTE Band 13	Yes	Yes	No	Yes	Yes	No
LTE Band 5 (Cell)	Yes	Yes	No	Yes	Yes	No
LTE Band 66 (AWS)	Yes	Yes	No	Yes	No	Yes
LTE Band 2 (PCS)	Yes	Yes	No	Yes	No	Yes
LTE Band 48	Yes	Yes	Yes	No	Yes	No
NR Band n5	Yes	Yes	No	Yes	Yes	No
NR Band n66	Yes	Yes	No	No	Yes	No
NR Band n2	Yes	Yes	No	No	Yes	No
2.4 GHz WLAN Ant 1	Yes	Yes	Yes	No	No	Yes
2.4 GHz WLAN Ant 2	Yes	Yes	Yes	No	No	Yes
2.4 GHz WLAN MIMO	Yes	Yes	Yes	No	No	Yes
5 GHz WLAN Ant 1	Yes	Yes	Yes	No	No	Yes
5 GHz WLAN Ant 2	Yes	Yes	Yes	No	No	Yes
5 GHz WLAN MIMO	Yes	Yes	Yes	No	No	Yes
Bluetooth	Yes	Yes	Yes	No	No	Yes



Note: Particular DUT edges were not required to be evaluated for wireless router SAR or phablet SAR if the edges were greater than 2.5 cm from the transmitting antenna according to FCC KDB Publication 941225 D06v02r01 Section III and FCC KDB Publication 648474 D04v01r03. The distances between the transmit antennas and the edges of the device are included in the filing. When wireless router mode is enabled, U-NII-2A, U-NII-2C operations are disabled.

1.7 Near Field Communications (NFC) Antenna

This DUT has NFC operations. The NFC antenna is integrated into the device for this model. Therefore, all SAR tests were performed with the device which already incorporates the NFC antenna. A diagram showing the location of the NFC antenna can be found in Appendix E.

1.8 Simultaneous Transmission Capabilities

According to FCC KDB Publication 447498 D01v06, transmitters are considered to be operating simultaneously when there is overlapping transmission, with the exception of transmissions during network hand-offs with maximum hand-off duration less than 30 seconds.



FCC ID: ZNFG900VM	 PCTEST Proud to be part of 	SAR EVALUATION REPORT	 LG	Approved by: Quality Manager
Document S/N: 1M2006040088-01-R1.ZNF	Test Dates: 06/25/20 – 08/05/20	DUT Type: Portable Handset	Page 9 of 159	

This device contains multiple transmitters that may operate simultaneously, and therefore requires a simultaneous transmission analysis according to FCC KDB Publication 447498 D01v06 4.3.2 procedures.

**Table 1-2
Simultaneous Transmission Scenarios**

No.	Capable Transmit Configuration	Head	Body-Worn Accessory	Wireless Router	Phablet	Notes
1	1x CDMA voice + 2.4 GHz Wi-Fi	Yes	Yes	N/A	Yes	
2	1x CDMA voice + 5 GHz Wi-Fi	Yes	Yes	N/A	Yes	
3	1x CDMA voice + 2.4 GHz Bluetooth	Yes ^A	Yes	N/A	Yes	^A Bluetooth Tethering is considered
4	1x CDMA voice + 2.4 GHz Wi-Fi MIMO	Yes	Yes	N/A	Yes	
5	1x CDMA voice + 5 GHz Wi-Fi MIMO	Yes	Yes	N/A	Yes	
6	1x CDMA voice + 2.4 GHz Wi-Fi Ant 2 + 2.4 GHz Bluetooth	Yes ^A	Yes	N/A	Yes	^A Bluetooth Tethering is considered
7	1x CDMA voice + 2.4 GHz Bluetooth + 5 GHz Wi-Fi	Yes ^A	Yes	N/A	Yes	^A Bluetooth Tethering is considered
8	1x CDMA voice + 2.4 GHz Bluetooth + 5 GHz Wi-Fi MIMO	Yes ^A	Yes	N/A	Yes	^A Bluetooth Tethering is considered
9	1x CDMA voice + 2.4 GHz Wi-Fi Ant 1 + 5 GHz Wi-Fi Ant 2	Yes	Yes	N/A	Yes	
10	GSM voice + 2.4 GHz Wi-Fi	Yes	Yes	N/A	Yes	
11	GSM voice + 5 GHz Wi-Fi	Yes	Yes	N/A	Yes	
12	GSM voice + 2.4 GHz Bluetooth	Yes ^A	Yes	N/A	Yes	^A Bluetooth Tethering is considered
13	GSM voice + 2.4 GHz Wi-Fi MIMO	Yes	Yes	N/A	Yes	
14	GSM voice + 5 GHz Wi-Fi MIMO	Yes	Yes	N/A	Yes	
15	GSM voice + 2.4 GHz Wi-Fi Ant 2 + 2.4 GHz Bluetooth	Yes ^A	Yes	N/A	Yes	^A Bluetooth Tethering is considered
16	GSM voice + 2.4 GHz Bluetooth + 5 GHz Wi-Fi	Yes ^A	Yes	N/A	Yes	^A Bluetooth Tethering is considered
17	GSM voice + 2.4 GHz Bluetooth + 5 GHz Wi-Fi MIMO	Yes ^A	Yes	N/A	Yes	^A Bluetooth Tethering is considered
18	GSM voice + 2.4 GHz Wi-Fi Ant 1 + 5 GHz Wi-Fi Ant 2	Yes	Yes	N/A	Yes	
19	UMTS + 2.4 GHz Wi-Fi	Yes	Yes	Yes	Yes	
20	UMTS + 5 GHz Wi-Fi	Yes	Yes	Yes	Yes	
21	UMTS + 2.4 GHz Bluetooth	Yes ^A	Yes	Yes ^A	Yes	^A Bluetooth Tethering is considered
22	UMTS + 2.4 GHz Wi-Fi MIMO	Yes	Yes	Yes	Yes	
23	UMTS + 5 GHz Wi-Fi MIMO	Yes	Yes	Yes	Yes	
24	UMTS + 2.4 GHz Wi-Fi Ant 2 + 2.4 GHz Bluetooth	Yes ^A	Yes	Yes ^A	Yes	^A Bluetooth Tethering is considered
25	UMTS + 2.4 GHz Bluetooth + 5 GHz Wi-Fi	Yes ^A	Yes	Yes ^A	Yes	^A Bluetooth Tethering is considered
26	UMTS + 2.4 GHz Bluetooth + 5 GHz Wi-Fi MIMO	Yes ^A	Yes	Yes ^A	Yes	^A Bluetooth Tethering is considered
27	UMTS + 2.4 GHz Wi-Fi Ant 1 + 5 GHz Wi-Fi Ant 2	Yes	Yes	Yes	Yes	
28	LTE + 2.4 GHz Wi-Fi	Yes	Yes	Yes	Yes	
29	LTE + 5 GHz Wi-Fi	Yes	Yes	Yes	Yes	
30	LTE + 2.4 GHz Bluetooth	Yes ^A	Yes	Yes ^A	Yes	^A Bluetooth Tethering is considered
31	LTE + 2.4 GHz Wi-Fi MIMO	Yes	Yes	Yes	Yes	
32	LTE + 5 GHz Wi-Fi MIMO	Yes	Yes	Yes	Yes	
33	LTE + 2.4 GHz Wi-Fi Ant 2 + 2.4 GHz Bluetooth	Yes ^A	Yes	Yes ^A	Yes	^A Bluetooth Tethering is considered
34	LTE + 2.4 GHz Bluetooth + 5 GHz Wi-Fi	Yes ^A	Yes	Yes ^A	Yes	^A Bluetooth Tethering is considered
35	LTE + 2.4 GHz Bluetooth + 5 GHz Wi-Fi MIMO	Yes ^A	Yes	Yes ^A	Yes	^A Bluetooth Tethering is considered
36	LTE + 2.4 GHz Wi-Fi Ant 1 + 5 GHz Wi-Fi Ant 2	Yes	Yes	Yes	Yes	
37	LTE + 5G NR	Yes	Yes	N/A	Yes	
38	LTE + 5 GHz Wi-Fi + 5G NR	Yes	Yes	Yes	Yes	
39	LTE + 2.4 GHz Wi-Fi + 5G NR	Yes	Yes	Yes	Yes	
40	LTE + 2.4 GHz Bluetooth + 5G NR	Yes ^A	Yes	Yes ^A	Yes	^A Bluetooth Tethering is considered
41	LTE + 2.4 GHz Wi-Fi MIMO + 5G NR	Yes	Yes	Yes	Yes	
42	LTE + 5 GHz Wi-Fi MIMO + 5G NR	Yes	Yes	Yes	Yes	
43	LTE + 2.4 GHz Wi-Fi Ant 2 + 2.4 GHz Bluetooth + 5G NR	Yes ^A	Yes	Yes ^A	Yes	^A Bluetooth Tethering is considered
44	LTE + 2.4 GHz Bluetooth + 5 GHz Wi-Fi + 5G NR	Yes ^A	Yes	Yes ^A	Yes	^A Bluetooth Tethering is considered
45	LTE + 2.4 GHz Bluetooth + 5 GHz Wi-Fi MIMO + 5G NR	Yes ^A	Yes	Yes ^A	Yes	^A Bluetooth Tethering is considered
46	LTE + 2.4 GHz Wi-Fi Ant 1 + 5 GHz Wi-Fi Ant 2 + 5G NR	Yes	Yes	Yes	Yes	
47	CDMA/EVDO + 2.4 GHz Wi-Fi	Yes*	Yes*	Yes	Yes	* Pre-installed VOIP applications are considered
48	CDMA/EVDO + 5 GHz Wi-Fi	Yes*	Yes*	Yes	Yes	* Pre-installed VOIP applications are considered
49	CDMA/EVDO + 2.4 GHz Bluetooth	Yes ^A	Yes*	Yes ^A	Yes	* Pre-installed VOIP applications are considered ^A Bluetooth Tethering is considered
50	CDMA/EVDO + 2.4 GHz Wi-Fi MIMO	Yes*	Yes*	Yes	Yes	* Pre-installed VOIP applications are considered
51	CDMA/EVDO + 5 GHz Wi-Fi MIMO	Yes*	Yes*	Yes	Yes	* Pre-installed VOIP applications are considered
52	CDMA/EVDO + 2.4 GHz Wi-Fi Ant 2 + 2.4 GHz Bluetooth	Yes ^A	Yes*	Yes ^A	Yes	* Pre-installed VOIP applications are considered ^A Bluetooth Tethering is considered
53	CDMA/EVDO + 2.4 GHz Bluetooth + 5 GHz Wi-Fi	Yes ^A	Yes*	Yes ^A	Yes	* Pre-installed VOIP applications are considered ^A Bluetooth Tethering is considered
54	CDMA/EVDO + 2.4 GHz Bluetooth + 5 GHz Wi-Fi MIMO	Yes ^A	Yes*	Yes ^A	Yes	* Pre-installed VOIP applications are considered ^A Bluetooth Tethering is considered
55	CDMA/EVDO + 2.4 GHz Wi-Fi Ant 1 + 5 GHz Wi-Fi Ant 2	Yes*	Yes*	Yes	Yes	* Pre-installed VOIP applications are considered
56	GPRS/EDGE + 2.4 GHz Wi-Fi	Yes*	Yes*	Yes	Yes	* Pre-installed VOIP applications are considered
57	GPRS/EDGE + 5 GHz Wi-Fi	Yes*	Yes*	Yes	Yes	* Pre-installed VOIP applications are considered
58	GPRS/EDGE + 2.4 GHz Bluetooth	Yes ^A	Yes*	Yes ^A	Yes	* Pre-installed VOIP applications are considered ^A Bluetooth Tethering is considered
59	GPRS/EDGE + 2.4 GHz Wi-Fi MIMO	Yes*	Yes*	Yes	Yes	* Pre-installed VOIP applications are considered
60	GPRS/EDGE + 5 GHz Wi-Fi MIMO	Yes*	Yes*	Yes	Yes	* Pre-installed VOIP applications are considered
61	GPRS/EDGE + 2.4 GHz Wi-Fi Ant 2 + 2.4 GHz Bluetooth	Yes ^A	Yes*	Yes ^A	Yes	* Pre-installed VOIP applications are considered ^A Bluetooth Tethering is considered
62	GPRS/EDGE + 2.4 GHz Bluetooth + 5 GHz Wi-Fi	Yes ^A	Yes*	Yes ^A	Yes	* Pre-installed VOIP applications are considered ^A Bluetooth Tethering is considered
63	GPRS/EDGE + 2.4 GHz Bluetooth + 5 GHz Wi-Fi MIMO	Yes ^A	Yes*	Yes ^A	Yes	* Pre-installed VOIP applications are considered ^A Bluetooth Tethering is considered
64	GPRS/EDGE + 2.4 GHz Wi-Fi Ant 1 + 5 GHz Wi-Fi Ant 2	Yes*	Yes*	Yes	Yes	* Pre-installed VOIP applications are considered

- 2.4 GHz WLAN antenna 1 and 2.4 GHz Bluetooth share the same antenna path and cannot transmit simultaneously.
- When the user utilizes multiple services in UMTS 3G mode it uses multi-Radio Access Bearer or multi-RAB. The power control is based on a physical control channel (Dedicated Physical Control Channel

FCC ID: ZNFG900VM	 PCTEST Proud to be part of  element	SAR EVALUATION REPORT		Approved by: Quality Manager
Document S/N: 1M2006040088-01-R1.ZNF	Test Dates: 06/25/20 – 08/05/20	DUT Type: Portable Handset		Page 10 of 159

[DPCCH]) and power control will be adjusted to meet the needs of both services. Therefore, the UMTS+WLAN scenario also represents the UMTS Voice/DATA + WLAN Hotspot scenario.

3. Per the manufacturer, WIFI Direct is expected to be used in conjunction with a held-to-ear or body-worn accessory voice call. Therefore, there are no simultaneous transmission scenarios involving WIFI direct beyond that listed in the above table.
4. 5 GHz Wireless Router is only supported for the U-NII-1 and U-NII-3 by S/W, therefore U-NII-2A, and U-NII-2C were not evaluated for wireless router conditions.
5. This device supports 2x2 MIMO Tx for WLAN 802.11a/g/n/ac. 802.11a/g/n/ac supports CDD and STBC and 802.11n/ac additionally supports SDM. Each WLAN antenna can transmit independently or together when operating with MIMO.
6. This device supports VOLTE.
7. This device supports VOWIFI.
8. This device supports Bluetooth Tethering.
9. LTE + 5G NR FR1 Scenarios are limited to LTE Anchor Bands, B2/B5/B13/B66
10. LTE operations in the table above include intra-band operations with 2 carriers transmitting in the uplink.
11. LTE + 5G NR FR2 n260 and n261 operations are possible only with LTE B2/5/13/48/66 under EN-DC mode.

1.9 Miscellaneous SAR Test Considerations

(A) WIFI/BT



Since U-NII-1 and U-NII-2A bands have the same maximum output power and the highest reported SAR for U-NII-2A is less than 1.2 W/kg, head and body-worn SAR is not required for U-NII-1 band according to FCC KDB Publication 248227 D01v02r02.

Since Wireless Router operations are not allowed by the chipset firmware using U-NII-2A and U-NII-2C WIFI, only 2.4 GHz, U-NII-1, and U-NII-3 WIFI Hotspot SAR tests and combinations are considered for SAR with respect to Wireless Router configurations according to FCC KDB 941225 D06v02r01.

Per FCC KDB Publication 648474 D04v01r03, this device is considered a "phablet" since the diagonal dimension is greater than 160mm and less than 200mm. Phablet SAR tests are required when wireless router mode does not apply or if wireless router 1g SAR > 1.2 W/kg. Because wireless router operations are not supported for U-NII-2A & U-NII-2C WLAN, phablet SAR tests were performed. Phablet SAR was not evaluated for 2.4 GHz WLAN, Bluetooth, U-NII-1, and U-NII-3 WLAN operations since wireless router 1g SAR was < 1.2 W/kg.

This device supports IEEE 802.11ac with the following features:

- a) Up to 80 MHz Bandwidth only for 5GHz
- b) Up to 20 MHz Bandwidth only for 2.4 GHz
- c) No aggregate channel configurations
- d) 2 Tx antenna output
- e) Up to 1024 QAM is supported
- f) TDWR and Band gap channels are supported
- g) MU-MIMO UL Operations are not supported

FCC ID: ZNFG900VM	 PCTEST Proud to be part of 	SAR EVALUATION REPORT	 LG	Approved by: Quality Manager
Document S/N: 1M2006040088-01-R1.ZNF	Test Dates: 06/25/20 – 08/05/20	DUT Type: Portable Handset	Page 11 of 159	

(B) Licensed Transmitter(s)

GSM/GPRS/EDGE DTM is not supported for US bands. Therefore, the GSM Voice modes in this report do not transmit simultaneously with GPRS/EDGE Data.

This device is only capable of QPSK HSUPA in the uplink. Therefore, no additional SAR tests are required beyond that described for devices with HSUPA in KDB 941225 D01v03r01.

LTE SAR for the higher modulations and lower bandwidths were not tested since the maximum average output power of all required channels and configurations was not more than 0.5 dB higher than the highest bandwidth; and the reported LTE SAR for the highest bandwidth was less than 1.45 W/kg for all configurations according to FCC KDB 941225 D05v02r04.

This device supports LTE Carrier Aggregation (CA) in the downlink. All uplink communications are identical to Release 8 specifications. Per FCC KDB Publication 941225 D05A v01r02, SAR for LTE CA operations was not needed since the maximum average output power in LTE CA mode was not >0.25 dB higher than the maximum output power when downlink carrier aggregation was inactive. Appendix F contains downlink carrier aggregation power measurements for bands impacted by this permissive change, per FCC guidance.

Per FCC KDB Publication 648474 D04v01r03, this device is considered a "phablet" since the diagonal dimension is greater than 160mm and less than 200mm. Therefore, phablet SAR tests are required when wireless router mode does not apply or if wireless router 1g SAR > 1.2 W/kg. Additional SAR tests for phablet SAR were evaluated per KDB 616217 Section 6 (See Section 6.9 for more information).

This device supports LTE capabilities with overlapping transmission frequency ranges. When the supported frequency range of an LTE Band falls completely within an LTE band with a larger transmission frequency range, both LTE bands have the same target power (or the band with the larger transmission frequency range has a higher target power), and both LTE bands share the same transmission path and signal characteristics, SAR was only assessed for the band with the larger transmission frequency range.



This device supports intra-band LTE Carrier Aggregation (CA) for LTE Band 5 with two component carriers in the uplink. SAR Measurements and conducted powers were evaluated per 2017 Fall TCB Workshop Notes.

This device supports downlink 4x4 MIMO operations for some LTE Bands. Per May 2017 TCB Workshop Notes, SAR for 4x4 DL MIMO was not needed since the maximum average output power in 4x4 DL MIMO mode was not more than 0.25 dB higher than the maximum output power with 4x4 DL MIMO inactive. Additionally, SAR for 4x4 MIMO Downlink Carrier Aggregation was not needed since the maximum average output power in 4x4 MIMO Downlink Carrier Aggregation mode was not more than 0.25 dB higher than the maximum output power with 4x4 MIMO Downlink and downlink carrier aggregation inactive.

NR implementation of n5, n66, n2 is limited to EN-DC operations only, with LTE B2/B5/B13/B66 acting as the anchor bands. Per FCC Guidance, SAR tests were performed separately for NR Bands and LTE Anchor Bands. Please see Section 11 for more details.

This device supports 64QAM on the uplink and 256QAM on the downlink for LTE Operations. Conducted powers for 64QAM uplink configurations were measured per Section 5.1 of FCC KDB Publication 941225D05v02r05. SAR was not required for 64QAM since the highest maximum output power for 64QAM is $\leq \frac{1}{2}$ dB higher than the same configuration in QPSK and the reported SAR for the QPSK configuration is ≤ 1.45 W/kg, per Section 5.2.4 of FCC KDB Publication 941225 D05v02r05.

This device supports 5G NR for Bands n260, and n261. RF Exposure assessment and simultaneous transmission analysis for these bands can be found in test report 1M2006040088-16-R1.ZNF.

FCC ID: ZNFG900VM	 PCTEST Proud to be part of 	SAR EVALUATION REPORT		Approved by: Quality Manager
Document S/N: 1M2006040088-01-R1.ZNF	Test Dates: 06/25/20 – 08/05/20	DUT Type: Portable Handset		Page 12 of 159

1.10 Guidance Applied



- IEEE 1528-2013
- FCC KDB Publication 941225 D01v03r01, D05v02r04, D05Av01r02, D06v02r01 (2G/3G/4G and Hotspot)
- FCC KDB Publication 248227 D01v02r02 (SAR Considerations for 802.11 Devices)
- FCC KDB Publication 447498 D01v06 (General SAR Guidance)
- FCC KDB Publication 865664 D01v01r04, D02v01r02 (SAR Measurements up to 6 GHz)
- FCC KDB Publication 648474 D04v01r03 (Phablet Procedures)
- FCC KDB Publication 616217 D04v01r02 (Proximity Sensor)
- October 2013 TCB Workshop Notes (GPRS Testing Considerations)
- May 2017 TCB Workshop Notes (LTE 4x4 Downlink MIMO)
- April 2018 TCB Workshop Notes (LTE Carrier Aggregation)
- April 2019 TCB Workshop Notes (Dynamic Antenna Tuning)

1.11 Device Serial Numbers

Several samples with identical hardware were used to support SAR testing. The manufacturer has confirmed that the device(s) tested have the same physical, mechanical and thermal characteristics and are within operational tolerances expected for production units. The serial numbers used for each test are indicated alongside the results in Section 11.

1.12 Bibliography



Report Type	Report Serial Number
RF Exposure Part 0 Test Report	Rev. F
RF Exposure Part 2 Test Report	1M2006040088-17.ZNF
Near-Field Power Density Evaluation Report	1M2006040088-16-R1.ZNF
RF Exposure Compliance Summary Report	1M2006040088-18.ZNF
PD Evaluation Report (Part 0)	Rev. B (Ver. 1.0)
PD Simulation Report	Rev. B (Ver. 1.0)

FCC ID: ZNFG900VM	 PCTEST Proud to be part of 	SAR EVALUATION REPORT	 LG	Approved by: Quality Manager
Document S/N: 1M2006040088-01-R1.ZNF	Test Dates: 06/25/20 – 08/05/20	DUT Type: Portable Handset	Page 13 of 159	



2

LTE AND NR INFORMATION

LTE Information					
Form Factor	Portable Handset				
Frequency Range of each LTE transmission band	LTE Band 12 (699.7 - 715.3 MHz)				
	LTE Band 13 (779.5 - 784.5 MHz)				
	LTE Band 5 (Cell) (824.7 - 848.3 MHz)				
	LTE Band 66 (AWS) (1710.7 - 1779.3 MHz)				
	LTE Band 4 (AWS) (1710.7 - 1754.3 MHz)				
	LTE Band 2 (PCS) (1850.7 - 1909.3 MHz)				
	LTE Band 48 (3552.5 - 3697.5 MHz)				
Channel Bandwidths	LTE Band 12: 1.4 MHz, 3 MHz, 5 MHz, 10 MHz				
	LTE Band 13: 5 MHz, 10 MHz				
	LTE Band 5 (Cell): 1.4 MHz, 3 MHz, 5 MHz, 10 MHz				
	LTE Band 66 (AWS): 1.4 MHz, 3 MHz, 5 MHz, 10 MHz, 15 MHz, 20 MHz				
	LTE Band 4 (AWS): 1.4 MHz, 3 MHz, 5 MHz, 10 MHz, 15 MHz, 20 MHz				
	LTE Band 2 (PCS): 1.4 MHz, 3 MHz, 5 MHz, 10 MHz, 15 MHz, 20 MHz				
Channel Numbers and Frequencies (MHz)	LTE Band 48: 5 MHz, 10 MHz, 15 MHz, 20 MHz				
	Low	Low-Mid	Mid	Mid-High	High
LTE Band 12: 1.4 MHz	699.7 (23017)		707.5 (23095)		715.3 (23173)
LTE Band 12: 3 MHz	700.5 (23025)		707.5 (23095)		714.5 (23165)
LTE Band 12: 5 MHz	701.5 (23035)		707.5 (23095)		713.5 (23155)
LTE Band 12: 10 MHz	704 (23060)		707.5 (23095)		711 (23130)
LTE Band 13: 5 MHz	779.5 (23205)		782 (23230)		784.5 (23255)
LTE Band 13: 10 MHz	N/A		782 (23230)		N/A
LTE Band 5 (Cell): 1.4 MHz	824.7 (20407)		836.5 (20525)		848.3 (20643)
LTE Band 5 (Cell): 3 MHz	825.5 (20415)		836.5 (20525)		847.5 (20635)
LTE Band 5 (Cell): 5 MHz	826.5 (20425)		836.5 (20525)		846.5 (20625)
LTE Band 5 (Cell): 10 MHz	829 (20450)		836.5 (20525)		844 (20600)
LTE Band 66 (AWS): 1.4 MHz	1710.7 (131979)		1745 (132322)		1779.3 (132665)
LTE Band 66 (AWS): 3 MHz	1711.5 (131987)		1745 (132322)		1778.5 (132657)
LTE Band 66 (AWS): 5 MHz	1712.5 (131997)		1745 (132322)		1777.5 (132647)
LTE Band 66 (AWS): 10 MHz	1715 (132022)		1745 (132322)		1775 (132622)
LTE Band 66 (AWS): 15 MHz	1717.5 (132047)		1745 (132322)		1772.5 (132597)
LTE Band 66 (AWS): 20 MHz	1720 (132072)		1745 (132322)		1770 (132572)
LTE Band 4 (AWS): 1.4 MHz	1710.7 (19957)		1732.5 (20175)		1754.3 (20393)
LTE Band 4 (AWS): 3 MHz	1711.5 (19965)		1732.5 (20175)		1753.5 (20385)
LTE Band 4 (AWS): 5 MHz	1712.5 (19975)		1732.5 (20175)		1752.5 (20375)
LTE Band 4 (AWS): 10 MHz	1715 (20000)		1732.5 (20175)		1750 (20350)
LTE Band 4 (AWS): 15 MHz	1717.5 (20025)		1732.5 (20175)		1747.5 (20325)
LTE Band 4 (AWS): 20 MHz	1720 (20050)		1732.5 (20175)		1745 (20300)
LTE Band 2 (PCS): 1.4 MHz	1850.7 (18607)		1880 (18900)		1909.3 (19193)
LTE Band 2 (PCS): 3 MHz	1851.5 (18615)		1880 (18900)		1908.5 (19185)
LTE Band 2 (PCS): 5 MHz	1852.5 (18625)		1880 (18900)		1907.5 (19175)
LTE Band 2 (PCS): 10 MHz	1855 (18650)		1880 (18900)		1905 (19150)
LTE Band 2 (PCS): 15 MHz	1857.5 (18675)		1880 (18900)		1902.5 (19125)
LTE Band 2 (PCS): 20 MHz	1860 (18700)		1880 (18900)		1900 (19100)
LTE Band 48: 5 MHz	3552.5 (55265)	3600.8 (55748)	N/A	3649.2 (56232)	3697.5 (56715)
LTE Band 48: 10 MHz	3555 (55290)	3601.7 (55757)	N/A	3648.3 (56223)	3695 (56690)
LTE Band 48: 15 MHz	3557.5 (55315)	3602.5 (55765)	N/A	3647.5 (56215)	3692.5 (56665)
LTE Band 48: 20 MHz	3560 (55340)	3603.3 (55773)	N/A	3646.7 (56207)	3690 (56640)
UE Category	DL UE Cat 18, UL UE Cat 13				
Modulations Supported in UL	QPSK, 16QAM, 64QAM				
LTE MPR Permanently implemented per 3GPP TS 36.101 section 6.2.3~6.2.5? (manufacturer attestation to be provided)	YES				
A-MPR (Additional MPR) disabled for SAR Testing?	YES				
LTE Carrier Aggregation Possible Combinations	The technical description includes all the possible carrier aggregation combinations				
LTE Additional Information	This device does not support full CA features on 3GPP Release 15. It supports carrier aggregation, downlink MIMO, LAA features as shown in section 9 and Appendix F. All other uplink communications are identical to the Release 8 specification. Uplink communications are done on the PCC. The following LTE Release 15 Features are not supported: Relay, HetNet, Enhanced MIMO, eICIC, eMBMS, Cross-Carrier Scheduling, Enhanced SC-FDMA.				

FCC ID: ZNFG900VM	 PCTEST Proud to be part of 	SAR EVALUATION REPORT		Approved by: Quality Manager
Document S/N: 1M2006040088-01-R1.ZNF	Test Dates: 06/25/20 – 08/05/20	DUT Type: Portable Handset		Page 14 of 159

NR FR1 Information			
Form Factor	Portable Handset		
Frequency Range of each LTE transmission band	NR Band n5 (Cell) (826.5 - 846.5 MHz)		
	NR Band n66 (AWS) (1712.5 - 1777.5 MHz)		
	NR Band n2 (PCS) (1852.5 - 1907.5 MHz)		
Channel Bandwidths	NR Band n5 (Cell): 5 MHz, 10 MHz, 15 MHz, 20 MHz		
	NR Band n66 (AWS): 5 MHz, 10 MHz, 15 MHz, 20 MHz		
	NR Band n2 (PCS): 5 MHz, 10 MHz, 15 MHz, 20 MHz		
Channel Numbers and Frequencies (MHz)	Low	Mid	High
NR Band n5 (Cell): 5 MHz	826.5 (165300)	836.5 (167300)	846.5 (169300)
NR Band n5 (Cell): 10 MHz	829 (165800)	836.5 (167300)	844 (168800)
NR Band n5 (Cell): 15 MHz	831.5 (166300)	836.5 (167300)	841.5 (168300)
NR Band n5 (Cell): 20 MHz	834 (166800)	836.5 (167300)	839 (167800)
NR Band n66 (AWS): 5 MHz	1712.5 (342500)	1745 (349000)	1777.5 (355500)
NR Band n66 (AWS): 10 MHz	1715 (343000)	1745 (349000)	1775 (355000)
NR Band n66 (AWS): 15 MHz	1717.5 (343500)	1745 (349000)	1772.5 (354500)
NR Band n66 (AWS): 20 MHz	1720 (344000)	1745 (349000)	1770 (354000)
NR Band n2 (PCS): 5 MHz	1852.5 (370500)	1880 (376000)	1907.5 (381500)
NR Band n2 (PCS): 10 MHz	1855 (371000)	1880 (376000)	1905 (381000)
NR Band n2 (PCS): 15 MHz	1857.5 (371500)	1880 (376000)	1902.5 (380500)
NR Band n2 (PCS): 20 MHz	1860 (372000)	1880 (376000)	1900 (380000)
SCS for NR Band n5/n66/n2	15 kHz		
Modulations Supported in UL	DFT-s-OFDM: $\pi/2$ BPSK, QPSK, 16QAM, 64QAM, 256QAM CP-OFDM: QPSK, 16QAM, 64QAM, 256QAM		
A-MPR (Additional MPR) disabled for SAR Testing?	YES		
EN-DC Carrier Aggregation Possible Combinations	The technical description includes all the possible carrier aggregation combinations		
LTE Anchor Bands for NR Band n5 (Cell)	LTE Band 2/66		
LTE Anchor Bands for NR Band n66 (AWS)	LTE Band 2/5/13		
LTE Anchor Bands for NR Band n2 (PCS)	LTE Band 5/13/66		

FCC ID: ZNFG900VM	 PCTEST Proud to be part of 	SAR EVALUATION REPORT		Approved by: Quality Manager
Document S/N: 1M2006040088-01-R1.ZNF	Test Dates: 06/25/20 – 08/05/20	DUT Type: Portable Handset	Page 15 of 159	

3

INTRODUCTION

The FCC and Innovation, Science, and Economic Development Canada have adopted the guidelines for evaluating the environmental effects of radio frequency (RF) radiation in ET Docket 93-62 on Aug. 6, 1996 and Health Canada Safety Code 6 to protect the public and workers from the potential hazards of RF emissions due to FCC-regulated portable devices. [1]

The safety limits used for the environmental evaluation measurements are based on the criteria published by the American National Standards Institute (ANSI) for localized specific absorption rate (SAR) in IEEE/ANSI C95.1-1992 Standard for Safety Levels with Respect to Human Exposure to Radio Frequency Electromagnetic Fields, 3 kHz to 300 GHz [3] and Health Canada RF Exposure Guidelines Safety Code 6 [22]. The measurement procedure described in IEEE/ANSI C95.3-2002 Recommended Practice for the Measurement of Potentially Hazardous Electromagnetic Fields - RF and Microwave [4] is used for guidance in measuring the Specific Absorption Rate (SAR) due to the RF radiation exposure from the Equipment Under Test (EUT). These criteria for SAR evaluation are similar to those recommended by the International Committee for Non-Ionizing Radiation Protection (ICNIRP) in Biological Effects and Exposure Criteria for Radiofrequency Electromagnetic Fields,” Report No. Vol 74. SAR is a measure of the rate of energy absorption due to exposure to an RF transmitting source. SAR values have been related to threshold levels for potential biological hazards.

3.1 SAR Definition

Specific Absorption Rate is defined as the time derivative (rate) of the incremental energy (dU) absorbed by (dissipated in) an incremental mass (dm) contained in a volume element (dV) of a given density (ρ). It is also defined as the rate of RF energy absorption per unit mass at a point in an absorbing body (see Equation 3-1).

Equation 3-1
SAR Mathematical Equation

$$SAR = \frac{d}{dt} \left(\frac{dU}{dm} \right) = \frac{d}{dt} \left(\frac{dU}{\rho dv} \right)$$



SAR is expressed in units of Watts per Kilogram (W/kg).

$$SAR = \frac{\sigma \cdot E^2}{\rho}$$

where:

- σ = conductivity of the tissue-simulating material (S/m)
- ρ = mass density of the tissue-simulating material (kg/m³)
- E = Total RMS electric field strength (V/m)

NOTE: The primary factors that control rate of energy absorption were found to be the wavelength of the incident field in relation to the dimensions and geometry of the irradiated organism, the orientation of the organism in relation to the polarity of field vectors, the presence of reflecting surfaces, and whether conductive contact is made by the organism with a ground plane.[6]

FCC ID: ZNFG900VM	 PCTEST Proud to be part of 	SAR EVALUATION REPORT	 LG	Approved by: Quality Manager
Document S/N: 1M2006040088-01-R1.ZNF	Test Dates: 06/25/20 – 08/05/20	DUT Type: Portable Handset	Page 16 of 159	

4 DOSIMETRIC ASSESSMENT

4.1 Measurement Procedure

The evaluation was performed using the following procedure compliant to FCC KDB Publication 865664 D01v01r04 and IEEE 1528-2013:

1. The SAR distribution at the exposed side of the head or body was measured at a distance no greater than 5.0 mm from the inner surface of the shell. The area covered the entire dimension of the device-head and body interface and the horizontal grid resolution was determined per FCC KDB Publication 865664 D01v01r04 (See Table 4-1) and IEEE 1528-2013.
2. The point SAR measurement was taken at the maximum SAR region determined from Step 1 to enable the monitoring of SAR fluctuations/drifts during the 1g/10g cube evaluation. SAR at this fixed point was measured and used as a reference value.
3. Based on the area scan data, the peak of the region with maximum SAR was determined by spline interpolation. Around this point, a volume was assessed according to the measurement resolution and volume size requirements of FCC KDB Publication 865664 D01v01r04 (See Table 4-1) and IEEE 1528-2013. On the basis of this data set, the spatial peak SAR value was evaluated with the following procedure (see references or the DASY manual online for more details):
 - a. SAR values at the inner surface of the phantom are extrapolated from the measured values along the line away from the surface with spacing no greater than that in Table 4-1. The extrapolation was based on a least-squares algorithm. A polynomial of the fourth order was calculated through the points in the z-axis (normal to the phantom shell).
 - b. After the maximum interpolated values were calculated between the points in the cube, the SAR was averaged over the spatial volume (1g or 10g) using a 3D-Spline interpolation algorithm. The 3D-spline is composed of three one-dimensional splines with the “Not a knot” condition (in x, y, and z directions). The volume was then integrated with the trapezoidal algorithm. One thousand points (10 x 10 x 10) were obtained through interpolation, in order to calculate the averaged SAR.
 - c. All neighboring volumes were evaluated until no neighboring volume with a higher average value was found.
4. The SAR reference value, at the same location as step 2, was re-measured after the zoom scan was complete to calculate the SAR drift. If the drift deviated by more than 5%, the SAR test and drift measurements were repeated.

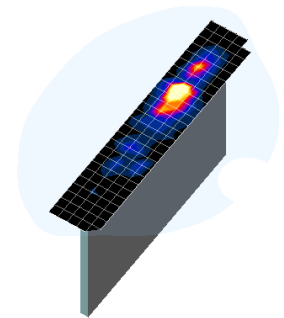





Figure 4-1
Sample SAR Area Scan

Table 4-1
Area and Zoom Scan Resolutions per FCC KDB Publication 865664 D01v01r04*

Frequency	Maximum Area Scan Resolution (mm) ($\Delta x_{\text{area}}, \Delta y_{\text{area}}$)	Maximum Zoom Scan Resolution (mm) ($\Delta x_{\text{zoom}}, \Delta y_{\text{zoom}}$)	Maximum Zoom Scan Spatial Resolution (mm)			Minimum Zoom Scan Volume (mm) (x,y,z)
			Uniform Grid	Graded Grid		
			$\Delta z_{\text{zoom}}(n)$	$\Delta z_{\text{zoom}}(1)^*$	$\Delta z_{\text{zoom}}(n>1)^*$	
≤ 2 GHz	≤ 15	≤ 8	≤ 5	≤ 4	≤ 1.5* $\Delta z_{\text{zoom}}(n-1)$	≥ 30
2-3 GHz	≤ 12	≤ 5	≤ 5	≤ 4	≤ 1.5* $\Delta z_{\text{zoom}}(n-1)$	≥ 30
3-4 GHz	≤ 12	≤ 5	≤ 4	≤ 3	≤ 1.5* $\Delta z_{\text{zoom}}(n-1)$	≥ 28
4-5 GHz	≤ 10	≤ 4	≤ 3	≤ 2.5	≤ 1.5* $\Delta z_{\text{zoom}}(n-1)$	≥ 25
5-6 GHz	≤ 10	≤ 4	≤ 2	≤ 2	≤ 1.5* $\Delta z_{\text{zoom}}(n-1)$	≥ 22

*Also compliant to IEEE 1528-2013 Table 6

FCC ID: ZNFG900VM	 PCTEST Proud to be part of 	SAR EVALUATION REPORT		Approved by: Quality Manager
Document S/N: 1M2006040088-01-R1.ZNF	Test Dates: 06/25/20 – 08/05/20	DUT Type: Portable Handset		Page 17 of 159

5 DEFINITION OF REFERENCE POINTS

5.1 EAR REFERENCE POINT

Figure 5-2 shows the front, back and side views of the SAM Twin Phantom. The point “M” is the reference point for the center of the mouth, “LE” is the left ear reference point (ERP), and “RE” is the right ERP. The ERP is 15mm posterior to the entrance to the ear canal (EEC) along the B-M line (Back-Mouth), as shown in Figure 5-1. The plane passing through the two ear canals and M is defined as the Reference Plane. The line N-F (Neck-Front), also called the Reference Pivoting Line, is not perpendicular to the reference plane (see Figure 5-1). Line B-M is perpendicular to the N-F line. Both N-F and B-M lines are marked on the external phantom shell to facilitate handset positioning [5].

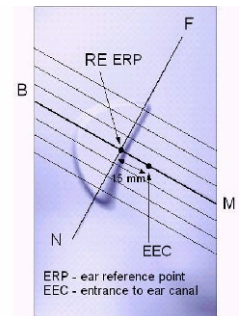

Figure 5-1
Close-Up Side view
of ERP

5.2 HANDSET REFERENCE POINTS

Two imaginary lines on the handset were established: the vertical centerline and the horizontal line. The test device was placed in a normal operating position with the acoustic output located along the “vertical centerline” on the front of the device aligned to the “ear reference point” (See Figure 5-3). The acoustic output was then located at the same level as the center of the ear reference point. The test device was positioned so that the “vertical centerline” was bisecting the front surface of the handset at its top and bottom edges, positioning the “ear reference point” on the outer surface of the both the left and right head phantoms on the ear reference point.

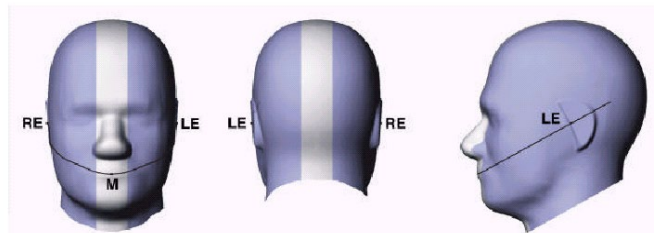

Figure 5-2
Front, back and side view of SAM Twin Phantom

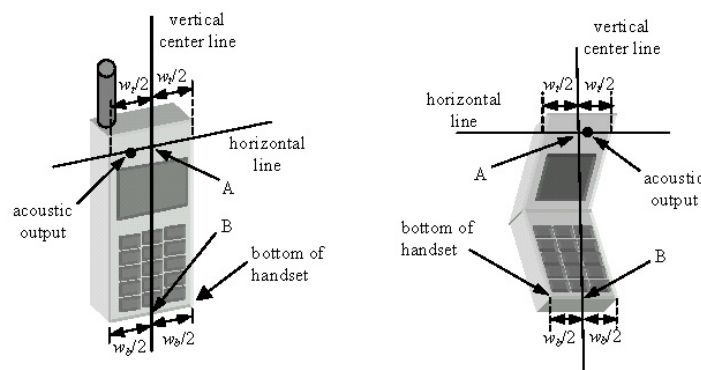



Figure 5-3
Handset Vertical Center & Horizontal Line Reference Points

FCC ID: ZNFG900VM	 PCTEST Proud to be part of element	SAR EVALUATION REPORT	 LG	Approved by: Quality Manager
Document S/N: 1M2006040088-01-R1.ZNF	Test Dates: 06/25/20 – 08/05/20	DUT Type: Portable Handset		Page 18 of 159

6 TEST CONFIGURATION POSITIONS

6.1 Device Holder

The device holder is made out of low-loss POM material having the following dielectric parameters: relative permittivity $\epsilon = 3$ and loss tangent $\delta = 0.02$.

6.2 Positioning for Cheek

1. The test device was positioned with the device close to the surface of the phantom such that point A is on the (virtual) extension of the line passing through points RE and LE on the phantom (see Figure 6-1), such that the plane defined by the vertical center line and the horizontal line of the phone is approximately parallel to the sagittal plane of the phantom.

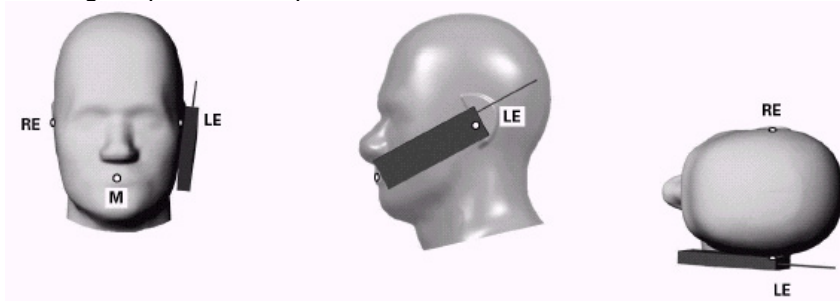





Figure 6-1 Front, Side and Top View of Cheek Position

2. The handset was translated towards the phantom along the line passing through RE & LE until the handset touches the pinna.
3. While maintaining the handset in this plane, the handset was rotated around the LE-RE line until the vertical centerline was in the reference plane.
4. The phone was then rotated around the vertical centerline until the phone (horizontal line) was symmetrical with respect to the line NF.
5. While maintaining the vertical centerline in the reference plane, keeping point A on the line passing through RE and LE, and maintaining the device contact with the ear, the device was rotated about the NF line until any point on the handset made contact with a phantom point below the ear (cheek) (See Figure 6-2).

6.3 Positioning for Ear / 15° Tilt

With the test device aligned in the “Cheek Position”:

1. While maintaining the orientation of the phone, the phone was retracted parallel to the reference plane far enough to enable a rotation of the phone by 15 degrees.
2. The phone was then rotated around the horizontal line by 15 degrees.
3. While maintaining the orientation of the phone, the phone was moved parallel to the reference plane until any part of the handset touched the head. (In this position, point A was located on the line RE-LE). The tilted position is obtained when the contact is on the pinna. If the contact was at any location other than the pinna, the angle of the phone would then be reduced. In this situation, the tilted position was obtained when any part of the phone was in contact of the ear as well as a second part of the phone was in contact with the head (see Figure 6-2).

FCC ID: ZNFG900VM	 PCTEST Proud to be part of 	SAR EVALUATION REPORT	 LG	Approved by: Quality Manager
Document S/N: 1M2006040088-01-R1.ZNF	Test Dates: 06/25/20 – 08/05/20	DUT Type: Portable Handset	Page 19 of 159	

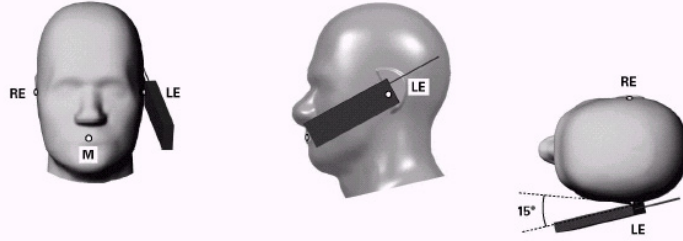

Figure 6-2 Front, Side and Top View of Ear/15° Tilt Position

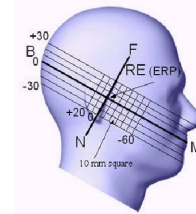

Figure 6-3 Side view w/ relevant markings

6.4 SAR Evaluations near the Mouth/Jaw Regions of the SAM Phantom

Antennas located near the bottom of a phone may require SAR measurements around the mouth and jaw regions of the SAM head phantom. This typically applies to clam-shell style phones that are generally longer in the unfolded normal use positions or to certain older style long rectangular phones. Per IEEE 1528-2013, a rotated SAM phantom is necessary to allow probe access to such regions. Both SAM heads of the TwinSAM-Chin20 are rotated 20 degrees around the NF line. Each head can be removed from the table for emptying and cleaning.

Under these circumstances, the following procedures apply, adopted from the FCC guidance on SAR handsets document FCC KDB Publication 648474 D04v01r03. The SAR required in these regions of SAM should be measured using a flat phantom. The phone should be positioned with a separation distance of 4 mm between the ear reference point (ERP) and the outer surface of the flat phantom shell. While maintaining this distance at the ERP location, the low (bottom) edge of the phone should be lowered from the phantom to establish the same separation distance between the peak SAR location identified by the truncated partial SAR distribution measured with the SAM phantom. The distance from the peak SAR location to the phone is determined by the straight line passing perpendicularly through the phantom surface. When it is not feasible to maintain 4 mm separation at the ERP while also establishing the required separation at the peak SAR location, the top edge of the phone will be allowed to touch the phantom with a separation < 4 mm at the ERP. The phone should not be tilted to the left or right while placed in this inclined position to the flat phantom.

6.5 Body-Worn Accessory Configurations

Body-worn operating configurations are tested with the belt-clips and holsters attached to the device and positioned against a flat phantom in a normal use configuration (see Figure 6-4). Per FCC KDB Publication 648474 D04v01r03, Body-worn accessory exposure is typically related to voice mode operations when handsets are carried in body-worn accessories. The body-worn accessory procedures in FCC KDB Publication 447498 D01v06 should be used to test for body-worn accessory SAR compliance, without a headset connected to it. This enables the test results for such configuration to be compatible with that required for hotspot mode when the body-worn accessory test separation distance is greater than or equal to that required for hotspot mode, when applicable. When the reported SAR for a body-worn accessory, measured without a headset connected to the handset, is > 1.2 W/kg, the highest reported SAR configuration for that wireless mode and frequency band should be repeated for that body-worn accessory with a headset attached to the handset.

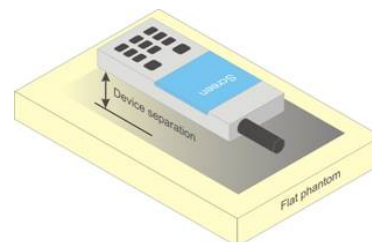





Figure 6-4 Sample Body-Worn Diagram

Accessories for Body-worn operation configurations are divided into two categories: those that do not contain metallic components and those that do contain metallic components. When multiple accessories that do not contain metallic components are supplied with the device, the device is tested with only the accessory that

FCC ID: ZNFG900VM	 PCTEST Proud to be part of 	SAR EVALUATION REPORT		Approved by: Quality Manager
Document S/N: 1M2006040088-01-R1.ZNF	Test Dates: 06/25/20 – 08/05/20	DUT Type: Portable Handset		Page 20 of 159

dictates the closest spacing to the body. Then multiple accessories that contain metallic components are tested with the device with each accessory. If multiple accessories share an identical metallic component (i.e. the same metallic belt-clip used with different holsters with no other metallic components) only the accessory that dictates the closest spacing to the body is tested.

Body-worn accessories may not always be supplied or available as options for some devices intended to be authorized for body-worn use. In this case, a test configuration with a separation distance between the back of the device and the flat phantom is used. Test position spacing was documented. Transmitters that are designed to operate in front of a person's face, as in push-to-talk configurations, are tested for SAR compliance with the front of the device positioned to face the flat phantom in head fluid. For devices that are carried next to the body such as a shoulder, waist or chest-worn transmitters, SAR compliance is tested with the accessories, including headsets and microphones, attached to the device and positioned against a flat phantom in a normal use configuration.

6.6 Extremity Exposure Configurations

Devices that are designed or intended for use on extremities or mainly operated in extremity only exposure conditions; i.e., hands, wrists, feet and ankles, may require extremity SAR evaluation. When the device also operates in close proximity to the user's body, SAR compliance for the body is also required. The 1g body and 10g extremity SAR Exclusion Thresholds found in KDB Publication 447498 D01v06 should be applied to determine SAR test requirements.

Per KDB Publication 447498 D01v06, Cell phones (handsets) are not normally designed to be used on extremities or operated in extremity only exposure conditions. The maximum output power levels of handsets generally do not require extremity SAR testing to show compliance. Therefore, extremity SAR was not evaluated for this device.



6.7 Wireless Router Configurations

Some battery-operated handsets have the capability to transmit and receive user data through simultaneous transmission of WIFI simultaneously with a separate licensed transmitter. The FCC has provided guidance in FCC KDB Publication 941225 D06v02r01 where SAR test considerations for handsets ($L \times W \geq 9 \text{ cm} \times 5 \text{ cm}$) are based on a composite test separation distance of 10 mm from the front, back and edges of the device containing transmitting antennas within 2.5 cm of their edges, determined from general mixed use conditions for this type of devices. Since the hotspot SAR results may overlap with the body-worn accessory SAR requirements, the more conservative configurations can be considered, thus excluding some body-worn accessory SAR tests.

When the user enables the personal wireless router functions for the handset, actual operations include simultaneous transmission of both the WIFI transmitter and another licensed transmitter. Both transmitters often do not transmit at the same transmitting frequency and thus cannot be evaluated for SAR under actual use conditions due to the limitations of the SAR assessment probes. Therefore, SAR must be evaluated for each frequency transmission and mode separately and spatially summed with the WIFI transmitter according to FCC KDB Publication 447498 D01v06 procedures. The "Portable Hotspot" feature on the handset was NOT activated during SAR assessments, to ensure the SAR measurements were evaluated for a single transmission frequency RF signal at a time.

6.8 Phablet Configurations

For smart phones with a display diagonal dimension > 150 mm or an overall diagonal dimension > 160 mm that provide similar mobile web access and multimedia support found in mini-tablets or UMPC mini-tablets that support voice calls next to the ear, the phablets procedures outlined in KDB Publication 648474 D04v01r03 should be applied to evaluate SAR compliance. A device marketed as phablets, regardless of form factors and operating characteristics must be tested as a phablet to determine SAR compliance.



FCC ID: ZNFG900VM	 PCTEST Proud to be part of  element	SAR EVALUATION REPORT	 LG	Approved by: Quality Manager
Document S/N: 1M2006040088-01-R1.ZNF	Test Dates: 06/25/20 – 08/05/20	DUT Type: Portable Handset	Page 21 of 159	

6.9 Proximity Sensor Considerations

This device uses a power reduction mechanism to reduce output powers in certain use conditions when the device is used close the user's body.

When the device's antenna is within a certain distance of the user, the sensor activates and reduces the maximum allowed output power. However, the sensor is not active when the device is moved beyond the sensor triggering distance and the maximum output power is no longer limited. Therefore, additional evaluation is needed in the vicinity of the triggering distance to ensure SAR is compliant when the device is allowed to operate at a non-reduced output power level. FCC KDB Publication 616217 D04v01r02 Section 6 was used as a guideline for selecting SAR test distances for this device at these additional test positions. Sensor triggering distance summary data is included in Appendix G.

The sensor is designed to support sufficient detection range and sensitivity to cover regions of the sensors in all applicable directions since the sensor entirely covers the antennas.

FCC ID: ZNFG900VM	 PCTEST <small>Proud to be part of element</small>	SAR EVALUATION REPORT		Approved by: Quality Manager
Document S/N: 1M2006040088-01-R1.ZNF	Test Dates: 06/25/20 – 08/05/20	DUT Type: Portable Handset	Page 22 of 159	

7 RF EXPOSURE LIMITS

7.1 Uncontrolled Environment

UNCONTROLLED ENVIRONMENTS are defined as locations where there is the exposure of individuals who have no knowledge or control of their exposure. The general population/uncontrolled exposure limits are applicable to situations in which the general public may be exposed or in which persons who are exposed as a consequence of their employment may not be made fully aware of the potential for exposure or cannot exercise control over their exposure. Members of the general public would come under this category when exposure is not employment-related; for example, in the case of a wireless transmitter that exposes persons in its vicinity.



7.2 Controlled Environment

CONTROLLED ENVIRONMENTS are defined as locations where there is exposure that may be incurred by persons who are aware of the potential for exposure, (i.e. as a result of employment or occupation). In general, occupational/controlled exposure limits are applicable to situations in which persons are exposed as a consequence of their employment, who have been made fully aware of the potential for exposure and can exercise control over their exposure. This exposure category is also applicable when the exposure is of a transient nature due to incidental passage through a location where the exposure levels may be higher than the general population/uncontrolled limits, but the exposed person is fully aware of the potential for exposure and can exercise control over his or her exposure by leaving the area or by some other appropriate means.

**Table 7-1
SAR Human Exposure Specified in ANSI/IEEE C95.1-1992 and Health Canada Safety Code 6**

HUMAN EXPOSURE LIMITS		
	UNCONTROLLED ENVIRONMENT <i>General Population</i> (W/kg) or (mW/g)	CONTROLLED ENVIRONMENT <i>Occupational</i> (W/kg) or (mW/g)
Peak Spatial Average SAR Head	1.6	8.0
Whole Body SAR	0.08	0.4
Peak Spatial Average SAR Hands, Feet, Ankle, Wrists, etc.	4.0	20

1. The Spatial Peak value of the SAR averaged over any 1 gram of tissue (defined as a tissue volume in the shape of a cube) and over the appropriate averaging time.
2. The Spatial Average value of the SAR averaged over the whole body.
3. The Spatial Peak value of the SAR averaged over any 10 grams of tissue (defined as a tissue volume in the shape of a cube) and over the appropriate averaging time.

FCC ID: ZNFG900VM	 PCTEST Proud to be part of 	SAR EVALUATION REPORT	 LG	Approved by: Quality Manager
Document S/N: 1M2006040088-01-R1.ZNF	Test Dates: 06/25/20 – 08/05/20	DUT Type: Portable Handset	Page 23 of 159	

Power measurements for licensed transmitters are performed using a base station simulator under digital average power.

8.1 Measured and Reported SAR

Per FCC KDB Publication 447498 D01v06, when SAR is not measured at the maximum power level allowed for production units, the results must be scaled to the maximum tune-up tolerance limit according to the power applied to the individual channels tested to determine compliance. For simultaneous transmission, the measured aggregate SAR must be scaled according to the sum of the differences between the maximum tune-up tolerance and actual power used to test each transmitter. When SAR is measured at or scaled to the maximum tune-up tolerance limit, the results are referred to as *reported* SAR. The highest *reported* SAR results are identified on the grant of equipment authorization according to procedures in KDB 690783 D01v01r03.

8.2 3G SAR Test Reduction Procedure

In FCC KDB Publication 941225 D01v03r01, certain transmission modes within a frequency band and wireless mode evaluated for SAR are defined as primary modes. The equivalent modes considered for SAR test reduction are denoted as secondary modes. When the maximum output power including tune-up tolerance specified for production units in a secondary mode is ≤ 0.25 dB higher than the primary mode or when the highest reported SAR of the primary mode, scaled by the ratio of specified maximum output power and tune-up tolerance of secondary to primary mode, is ≤ 1.2 W/kg, SAR measurements are not required for the secondary mode. These criteria are referred to as the 3G SAR test reduction procedure. When the 3G SAR test reduction procedure is not satisfied, SAR measurements are additionally required for the secondary mode.

8.3 Procedures Used to Establish RF Signal for SAR

The following procedures are according to FCC KDB Publication 941225 D01v03r01 “3G SAR Measurement Procedures.”



The device is placed into a simulated call using a base station simulator in a RF shielded chamber. Establishing connections in this manner ensure a consistent means for testing SAR and are recommended for evaluating SAR [4]. Devices under test are evaluated prior to testing, with a fully charged battery and were configured to operate at maximum output power. In order to verify that the device is tested throughout the SAR test at maximum output power, the SAR measurement system measures a “point SAR” at an arbitrary reference point at the start and end of the 1 gram SAR evaluation, to assess for any power drifts during the evaluation. If the power drift deviates by more than 5%, the SAR test and drift measurements are repeated.

8.4 SAR Measurement Conditions for CDMA2000

The following procedures were performed according to FCC KDB Publication 941225 D01v03r01 “3G SAR Measurement Procedures.”

8.4.1 Output Power Verification

See 3GPP2 C.S0011/TIA-98-E as recommended by FCC KDB Publication 941225 D01v03r01 “3G SAR Measurement Procedures.” Maximum output power is verified on the High, Middle and Low channels according to procedures in section 4.4.5.2 of 3GPP2 C.S0011/TIA-98-E. SO55 tests were measured with power control bits in the “All Up” condition.

FCC ID: ZNFG900VM	 PCTEST Proud to be part of 	SAR EVALUATION REPORT	 LG	Approved by: Quality Manager
Document S/N: 1M2006040088-01-R1.ZNF	Test Dates: 06/25/20 – 08/05/20	DUT Type: Portable Handset	Page 24 of 159	

1. If the mobile station (MS) supports Reverse TCH RC 1 and Forward TCH RC 1, set up a call using Fundamental Channel Test Mode 1 (RC=1/1) with 9600 bps data rate only.
2. Under RC1, C.S0011 Table 4.4.5.2-1, Table 8-1 parameters were applied.
3. If the MS supports the RC 3 Reverse FCH, RC3 Reverse SCH₀ and demodulation of RC 3,4, or 5, set up a call using Supplemental Channel Test Mode 3 (RC 3/3) with 9600 bps Fundamental Channel and 9600 bps SCH₀ data rate.
4. Under RC3, C.S0011 Table 4.4.5.2-2, Table 8-2 was applied.

Table 8-1
Parameters for Max. Power for RC1

Parameter	Units	Value
I_{or}	dBm/1.23 MHz	-104
$\frac{Pilot E_c}{I_{or}}$	dB	-7
$\frac{Traffic E_c}{I_{or}}$	dB	-7.4

Table 8-2
Parameters for Max. Power for RC3

Parameter	Units	Value
I_{or}	dBm/1.23 MHz	-86
$\frac{Pilot E_c}{I_{or}}$	dB	-7
$\frac{Traffic E_c}{I_{or}}$	dB	-7.4

5. FCHs were configured at full rate for maximum SAR with “All Up” power control bits.

8.4.2 Head SAR Measurements

SAR for next to the ear head exposure is measured in RC3 with the handset configured to transmit at full rate in SO55. The 3G SAR test reduction procedure is applied to RC1 with RC3 as the primary mode; otherwise, SAR is required for the channel with maximum measured output in RC1 using the head exposure configuration that results in the highest reported SAR in RC3.

Head SAR is additionally evaluated using EVDO Rev. A to support compliance for VoIP operations. See Section 8.4.5 for EVDO Rev. A configuration parameters.

8.4.3 Body-worn SAR Measurements



SAR for body-worn exposure configurations is measured in RC3 with the DUT configured to transmit at full rate on FCH with all other code channels disabled using TDSO / SO32. The 3G SAR test reduction procedure is applied to the multiple code channel configuration (FCH+SCH_n), with FCH only as the primary mode. Otherwise, SAR is required for multiple code channel configuration (FCH + SCH_n), with FCH at full rate and SCH₀ enabled at 9600 bps, using the highest reported SAR configuration for FCH only. When multiple code channels are enabled, the transmitter output can shift by more than 0.5 dB and may lead to higher SAR drifts and SCH dropouts.

The 3G SAR test reduction procedure is applied to body-worn accessory SAR in RC1 with RC3 as the primary mode. Otherwise, SAR is required for RC1, with SO55 and full rate, using the highest reported SAR configuration for body-worn accessory exposure in RC3.

8.4.4 Body-worn SAR Measurements for EVDO Devices

For handsets with EVDO capabilities, the 3G SAR test reduction procedure is applied to EVDO Rev. 0 with 1x RTT RC3 as the primary mode to determine body-worn accessory test requirements. Otherwise, body-worn accessory SAR is required for Rev. 0, at 153.6 kbps, using the highest reported SAR configuration for body-worn accessory exposure in RC3.

The 3G SAR test reduction procedure is applied to Rev. A, with Rev. 0 as the primary mode to determine body-worn accessory SAR test requirements. When SAR is not required for Rev. 0, the 3G SAR test reduction is applied with 1x RTT RC3 as the primary mode.

FCC ID: ZNFG900VM	 PCTEST Proud to be part of 	SAR EVALUATION REPORT		Approved by: Quality Manager
Document S/N: 1M2006040088-01-R1.ZNF	Test Dates: 06/25/20 – 08/05/20	DUT Type: Portable Handset		Page 25 of 159

When SAR is required for EVDO Rev. A, SAR is measured with a Reverse Data Channel payload size of 4096 bits and a Termination Target of 16 slots defined for Subtype 2 Physical Layer configurations, using the highest reported SAR configuration for body-worn accessory exposure in Rev. 0 or 1x RTT RC3, as appropriate.

8.4.5 Body SAR Measurements for EVDO Hotspot

Hotspot Body SAR is measured using Subtype 0/1 Physical Layer configurations for Rev. 0. The 3G SAR test reduction procedure is applied to Rev. A, Subtype 2 Physical layer configuration, with Rev. 0 as the primary mode; otherwise, SAR is measured for Rev. A using the highest reported SAR configuration for body-worn accessory exposure in Rev. 0. The AT is tested with a Reverse Data Channel rate of 153.6 kbps in Subtype 0/1 Physical Layer configurations; and a Reverse Data Channel payload size of 4096 bits and Termination Target of 16 slots in Subtype 2 Physical Layer configurations.

For EVDO data devices that also support 1x RTT voice and/or data operations, the 3G SAR test reduction procedure is applied to 1x RTT RC3 and RC1 with EVDO Rev. 0 and Rev. A as the respective primary modes. Otherwise, the 'Body-Worn Accessory SAR' procedures in the '3GPP2 CDMA 2000 1x Handsets' section are applied.

8.5 SAR Measurement Conditions for UMTS

8.5.1 Output Power Verification

Maximum output power is verified on the High, Middle and Low channels according to the general descriptions in section 5.2 of 3GPP TS 34.121, using the appropriate RMC with TPC (transmit power control) set to all "1s" or applying the required inner loop power control procedures to maintain maximum output power while HSUPA is active. Results for all applicable physical channel configurations (DPCCH, DPDCH_n and spreading codes, HS-DPCCH etc) are tabulated in this test report. All configurations that are not supported by the DUT or cannot be measured due to technical or equipment limitations are identified.

8.5.2 Head SAR Measurements



SAR for next to the ear head exposure is measured using a 12.2 kbps RMC with TPC bits configured to all "1s". The 3G SAR test reduction procedure is applied to AMR configurations with 12.2 kbps RMC as the primary mode. Otherwise, SAR is measured for 12.2 kbps AMR in 3.4 kbps SRB (signaling radio bearer) using the highest reported SAR configuration in 12.2 kbps RMC for head exposure.

8.5.3 Body SAR Measurements

SAR for body exposure configurations is measured using the 12.2 kbps RMC with the TPC bits all "1s". The 3G SAR test reduction procedure is applied to other spreading codes and multiple DPDCH_n configurations supported by the handset with 12.2 kbps RMC as the primary mode. Otherwise, SAR is measured using an applicable RMC configuration with the corresponding spreading code or DPDCH_n, for the highest reported SAR configuration in 12.2 kbps RMC.

8.5.4 SAR Measurements with Rel 5 HSDPA

The 3G SAR test reduction procedure is applied to HSDPA body configurations with 12.2 kbps RMC as the primary mode. Otherwise, Body SAR for HSDPA is measured using an FRC with H-Set 1 in Sub-test 1 and a 12.2 kbps RMC configured in Test Loop Mode 1, for the highest reported SAR configuration in 12.2 kbps RMC without HSDPA. Handsets with both HSDPA and HSUPA are tested according to Release 6 HSPA test procedures.

FCC ID: ZNFG900VM	 PCTEST Proud to be part of 	SAR EVALUATION REPORT		Approved by: Quality Manager
Document S/N: 1M2006040088-01-R1.ZNF	Test Dates: 06/25/20 – 08/05/20	DUT Type: Portable Handset	Page 26 of 159	

8.5.5 SAR Measurements with Rel 6 HSUPA

The 3G SAR test reduction procedure is applied to HSPA (HSUPA/HSDPA with RMC) body configurations with 12.2 kbps RMC as the primary mode. Otherwise, Body SAR for HSPA is measured with E-DCH Sub-test 5, using H-Set 1 and QPSK for FRC and a 12.2 kbps RMC configured in Test Loop Mode 1 and power control algorithm 2, according to the highest reported body SAR configuration in 12.2 kbps RMC without HSPA.

When VOIP applies to head exposure, the 3G SAR test reduction procedure is applied with 12.2 kbps RMC as the primary mode; otherwise, the same HSPA configuration used for body SAR measurements are applied to head exposure testing.

8.6 SAR Measurement Conditions for LTE

LTE modes are tested according to FCC KDB 941225 D05v02r04 publication. Establishing connections with base station simulators ensure a consistent means for testing SAR and are recommended for evaluating SAR [4]. The R&S CMW500 or Anritsu MT8820C simulators are used for LTE output power measurements and SAR testing. Closed loop power control was used so the UE transmits with maximum output power during SAR testing. SAR tests were performed with the same number of RB and RB offsets transmitting on all TTI frames (maximum TTI).

8.6.1 Spectrum Plots for RB Configurations

A properly configured base station simulator was used for SAR tests and power measurements. Therefore, spectrum plots for RB configurations were not required to be included in this report.

8.6.2 MPR

MPR is permanently implemented for this device by the manufacturer. The specific manufacturer target MPR is indicated alongside the SAR results. MPR is enabled for this device, according to 3GPP TS36.101 Section 6.2.3 – 6.2.5 under Table 6.2.3-1.



8.6.3 A-MPR

A-MPR (Additional MPR) has been disabled for all SAR tests by setting factory test parameters for MCC and MNC on the base station simulator.

8.6.4 Required RB Size and RB Offsets for SAR Testing

According to FCC KDB 941225 D05v02r04:

- a. Per Section 5.2.1, SAR is required for QPSK 1 RB Allocation for the largest bandwidth
 - i. The required channel and offset combination with the highest maximum output power is required for SAR.
 - ii. When the reported SAR is ≤ 0.8 W/kg, testing of the remaining RB offset configurations and required test channels is not required. Otherwise, SAR is required for the remaining required test channels using the RB offset configuration with highest output power for that channel.
 - iii. When the reported SAR for a required test channel is > 1.45 W/kg, SAR is required for all RB offset configurations for that channel.
- b. Per Section 5.2.2, SAR is required for 50% RB allocation using the largest bandwidth following the same procedures outlined in Section 5.2.1.

FCC ID: ZNFG900VM	 PCTEST Proud to be part of 	SAR EVALUATION REPORT	 LG	Approved by: Quality Manager
Document S/N: 1M2006040088-01-R1.ZNF	Test Dates: 06/25/20 – 08/05/20	DUT Type: Portable Handset	Page 27 of 159	

- c. Per Section 5.2.3, QPSK SAR is not required for the 100% allocation when the highest maximum output power for the 100% allocation is less than the highest maximum output power of the 1 RB and 50% RB allocations and the reported SAR for the 1 RB and 50% RB allocations is < 0.8 W/kg.
- d. Per Section 5.2.4 and 5.3, SAR tests for higher order modulations and lower bandwidths configurations are not required when the conducted power of the required test configurations determined by Sections 5.2.1 through 5.2.3 is less than or equal to ½ dB higher than the equivalent configuration using QPSK modulation and when the QPSK SAR for those configurations is <1.45 W/kg.

8.6.5 TDD

LTE TDD testing is performed using the SAR test guidance provided in FCC KDB 941225 D05v02r04. TDD is tested at the highest duty factor using UL-DL configuration 0 with special subframe configuration 6 and applying the FDD LTE procedures in KDB 941225 D05v02r04. SAR testing is performed using the extended cyclic prefix listed in 3GPP TS 36.211 Section 4.

8.6.6 Downlink Only Carrier Aggregation

Conducted power measurements with LTE Carrier Aggregation (CA) (downlink only) active are made in accordance to KDB Publication 941225 D05Av01r02. The RRC connection is only handled by one cell, the primary component carrier (PCC) for downlink and uplink communications. After making a data connection to the PCC, the UE device adds secondary component carrier(s) (SCC) on the downlink only. All uplink communications and acknowledgements remain identical to specifications when downlink carrier aggregation is inactive on the PCC. Additional conducted output powers are measured with the downlink carrier aggregation active for the configuration with highest measured maximum conducted power with downlink carrier aggregation inactive measured among the channel bandwidth, modulation, and RB combinations in each frequency band. Per FCC KDB Publication 941225 D05Av01r02, no SAR measurements are required for downlink only carrier aggregation configurations when the average output power with downlink only carrier aggregation active is not more than 0.25 dB higher than the average output power with downlink only carrier aggregation inactive.

8.7 SAR Testing with 802.11 Transmitters

The normal network operating configurations of 802.11 transmitters are not suitable for SAR measurements. Unpredictable fluctuations in network traffic and antenna diversity conditions can introduce undesirable variations in SAR results. The SAR for these devices should be measured using chipset based test mode software to ensure the results are consistent and reliable. See KDB Publication 248227 D01v02r02 for more details.



8.7.1 General Device Setup

Chipset based test mode software is hardware dependent and generally varies among manufacturers. The device operating parameters established in test mode for SAR measurements must be identical to those programmed in production units, including output power levels, amplifier gain settings and other RF performance tuning parameters.

A periodic duty factor is required for current generation SAR systems to measure SAR. When 802.11 frame gaps are accounted for in the transmission, a maximum transmission duty factor of 92 - 96% is typically achievable in most test mode configurations. A minimum transmission duty factor of 85% is required to avoid certain hardware and device implementation issues related to wide range SAR scaling. The reported SAR is scaled to 100% transmission duty factor to determine compliance at the maximum tune-up tolerance limit.

8.7.2 U-NII-1 and U-NII-2A

For devices that operate in both U-NII-1 and U-NII-2A bands, when the same maximum output power is specified for both bands, SAR measurement using OFDM SAR test procedures is not required for U-NII-1

FCC ID: ZNFG900VM	 PCTEST Proud to be part of 	SAR EVALUATION REPORT		Approved by: Quality Manager
Document S/N: 1M2006040088-01-R1.ZNF	Test Dates: 06/25/20 – 08/05/20	DUT Type: Portable Handset	Page 28 of 159	

unless the highest reported SAR for U-NII-2A is > 1.2 W/kg. When different maximum output powers are specified for the bands, SAR measurement for the U-NII band with the lower maximum output power is not required unless the highest reported SAR for the U-NII band with the higher maximum output power, adjusted by the ratio of lower to higher specified maximum output power for the two bands, is > 1.2 W/kg. When 10g SAR measurement is considered, a factor of 2.5 is applied to the thresholds above.

8.7.3 U-NII-2C and U-NII-3

The frequency range covered by U-NII-2C and U-NII-3 is 380 MHz (5.47 – 5.85 GHz), which requires a minimum of at least two SAR probe calibration frequency points to support SAR measurements. When Terminal Doppler Weather Radar (TDWR) restriction applies, the channels at 5.60 – 5.65 GHz in U-NII-2C band must be disabled with acceptable mechanisms and documented in the equipment certification. Unless band gap channels are permanently disabled, SAR must be considered for these channels. Each band is tested independently according to the normally required OFDM SAR measurement and probe calibration frequency points requirements.

8.7.4 Initial Test Position Procedure

For exposure conditions with multiple test positions, such as handset operating next to the ear, devices with hotspot mode or UMPC mini-tablet, procedures for initial test position can be applied. Using the transmission mode determined by the DSSS procedure or initial test configuration, area scans are measured for all positions in an exposure condition. The test position with the highest extrapolated (peak) SAR is used as the initial test position. When reported SAR for the initial test position is ≤ 0.4 W/kg, no additional testing for the remaining test positions is required. Otherwise, SAR is evaluated at the subsequent highest peak SAR positions until the reported SAR result is ≤ 0.8 W/kg or all test positions are measured. When 10g SAR measurement is considered, a factor of 2.5 is applied to the thresholds above.

8.7.5 2.4 GHz SAR Test Requirements



SAR is measured for 2.4 GHz 802.11b DSSS using either the fixed test position or, when applicable, the initial test position procedure. SAR test reduction is determined according to the following:

- 1) When the reported SAR of the highest measured maximum output power channel for the exposure configuration is ≤ 0.8 W/kg, no further SAR testing is required for 802.11b DSSS in that exposure configuration.
- 2) When the reported SAR is > 0.8 W/kg, SAR is required for that position using the next highest measured output power channel. When any reported SAR is > 1.2 W/kg, SAR is required for the third channel; i.e., all channels require testing.

2.4 GHz 802.11 g/n OFDM are additionally evaluated for SAR if the highest reported SAR for 802.11b, adjusted by the ratio of the OFDM to DSSS specified maximum output power, is > 1.2 W/kg. When SAR is required for OFDM modes in 2.4 GHz band, the Initial Test Configuration Procedures should be followed. When 10g SAR measurement is considered, a factor of 2.5 is applied to the thresholds above.

8.7.6 OFDM Transmission Mode and SAR Test Channel Selection

When the same maximum output power was specified for multiple OFDM transmission mode configurations in a frequency band or aggregated band, SAR is measured using the configuration with the largest channel bandwidth, lowest order modulation and lowest data rate. When the maximum output power of a channel is the same for equivalent OFDM configurations; for example, 802.11a, 802.11n and 802.11ac or 802.11g and 802.11n with the same channel bandwidth, modulation and data rate etc., the lower order 802.11 mode i.e., 802.11a, then 802.11n and 802.11ac or 802.11g then 802.11n, is used for SAR measurement. When the maximum output power are the same for multiple test channels, either according to the default or additional power measurement requirements, SAR is measured using the channel closest to the middle of the frequency

FCC ID: ZNFG900VM	 PCTEST Proud to be part of 	SAR EVALUATION REPORT	 LG	Approved by: Quality Manager
Document S/N: 1M2006040088-01-R1.ZNF	Test Dates: 06/25/20 – 08/05/20	DUT Type: Portable Handset	Page 29 of 159	

band or aggregated band. When there are multiple channels with the same maximum output power, SAR is measured using the higher number channel.

8.7.7 Initial Test Configuration Procedure

For OFDM, an initial test configuration is determined for each frequency band and aggregated band, according to the transmission mode with the highest maximum output power specified for SAR measurements. When the same maximum output power is specified for multiple OFDM transmission mode configurations in a frequency band or aggregated band, SAR is measured using the configuration(s) with the largest channel bandwidth, lowest order modulation, lowest data rate and lowest order IEEE 802.11 mode. The channel of the transmission mode with the highest average RF output conducted power will be the initial test configuration.



When the reported SAR is ≤ 0.8 W/kg, no additional measurements on other test channels are required. Otherwise, SAR is evaluated using the subsequent highest average RF output channel until the reported SAR result is ≤ 1.2 W/kg or all channels are measured. When there are multiple untested channels having the same subsequent highest average RF output power, the channel with higher frequency from the lowest 802.11 mode is considered for SAR measurements (See Section 8.7.6). When 10g SAR measurement is considered, a factor of 2.5 is applied to the thresholds above.

8.7.8 Subsequent Test Configuration Procedures

For OFDM configurations in each frequency band and aggregated band, SAR is evaluated for initial test configuration using the fixed test position or the initial test position procedure. When the highest reported SAR (for the initial test configuration), adjusted by the ratio of the specified maximum output power of the subsequent test configuration to initial test configuration, is ≤ 1.2 W/kg, no additional SAR tests for the subsequent test configurations are required. When 10g SAR measurement is considered, a factor of 2.5 is applied to the thresholds above.

8.7.9 MIMO SAR Considerations

Per KDB Publication 248227 D01v02r02, the simultaneous SAR provisions in KDB Publication 447498 D01v06 should be applied to determine simultaneous transmission SAR test exclusion for WIFI MIMO. If the sum of 1g single transmission chain SAR measurements is < 1.6 W/kg, no additional SAR measurements for MIMO are required. Alternatively, SAR for MIMO can be measured with all antennas transmitting simultaneously at the specified maximum output power of MIMO operation. When 10g SAR measurement is considered, a factor of 2.5 is applied to the thresholds above.

FCC ID: ZNFG900VM	 PCTEST Proud to be part of 	SAR EVALUATION REPORT	 LG	Approved by: Quality Manager
Document S/N: 1M2006040088-01-R1.ZNF	Test Dates: 06/25/20 – 08/05/20	DUT Type: Portable Handset	Page 30 of 159	

9.1 GSM Conducted Powers

Table 9-1
Measured P_{max}



Maximum Burst-Averaged Output Power						
		Voice	GPRS/EDGE Data (GMSK)		EDGE Data (8-PSK)	
Band	Channel	GSM [dBm] CS (1 Slot)	GPRS [dBm] 1 Tx Slot	GPRS [dBm] 2 Tx Slot	EDGE [dBm] 1 Tx Slot	EDGE [dBm] 2 Tx Slot
GSM 850	128	33.24	33.21	31.46	26.39	26.01
	190	33.12	33.09	31.43	26.41	25.97
	251	33.05	33.04	31.37	26.32	25.94
GSM 1900	512	29.61	29.92	28.69	25.37	25.31
	661	29.84	29.89	28.99	25.73	25.46
	810	30.10	30.10	28.85	25.63	25.61

Calculated Maximum Frame-Averaged Output Power						
		Voice	GPRS/EDGE Data (GMSK)		EDGE Data (8-PSK)	
Band	Channel	GSM [dBm] CS (1 Slot)	GPRS [dBm] 1 Tx Slot	GPRS [dBm] 2 Tx Slot	EDGE [dBm] 1 Tx Slot	EDGE [dBm] 2 Tx Slot
GSM 850	128	24.04	24.01	25.27	17.19	19.82
	190	23.92	23.89	25.24	17.21	19.78
	251	23.85	23.84	25.18	17.12	19.75
GSM 1900	512	20.41	20.72	22.50	16.17	19.12
	661	20.64	20.69	22.80	16.53	19.27
	810	20.90	20.90	22.66	16.43	19.42

GSM 850	Frame	23.30	23.30	24.81	17.30	19.81
GSM 1900	Avg.Targets:	20.30	20.30	21.81	16.30	18.81

Note:

- Both burst-averaged and calculated frame-averaged powers are included. Frame-averaged power was calculated from the measured burst-averaged power by converting the slot powers into linear units and calculating the energy over 8 timeslots.
- GPRS/EDGE (GMSK) output powers were measured with coding scheme setting of 1 (CS1) on the base station simulator. CS1 was configured to measure GPRS output power measurements and SAR to ensure GMSK modulation in the signal. Our investigation has shown that CS1 - CS4 settings do not have any impact on the output levels or modulation in the GPRS modes.
- EDGE (8-PSK) output powers were measured with MCS7 on the base station simulator. MCS7 coding scheme was used to measure the output powers for EDGE since investigation has shown that choosing MCS7 coding scheme will ensure 8-PSK modulation. It has been shown that MCS levels that produce 8-PSK modulation do not have an impact on output power.

FCC ID: ZNFG900VM	 PCTEST Proud to be part of 	SAR EVALUATION REPORT		Approved by: Quality Manager
Document S/N: 1M2006040088-01-R1.ZNF	Test Dates: 06/25/20 – 08/05/20	DUT Type: Portable Handset		Page 31 of 159

GSM Class: B
 GPRS Multislot class: 10 (Max 2 Tx uplink slots)
 EDGE Multislot class: 10 (Max 2 Tx uplink slots)
 DTM Multislot Class: N/A



Figure 9-1
 Power Measurement Setup

9.2 CDMA Conducted Powers

Table 9-2
 Measured P_{max}

Band	Channel	Rule Part	Frequency	SO55 [dBm]	SO55 [dBm]	TDSO SO32 [dBm]	TDSO SO32 [dBm]	1x EvDO Rev. 0 [dBm]	1x EvDO Rev. A [dBm]
	F-RC		MHz	RC1	RC3	FCH+SCH	FCH	(RTAP)	(RETAP)
Cellular	1013	22H	824.7	25.42	25.40	25.39	25.38	24.73	24.72
	384	22H	836.52	25.47	25.44	25.45	25.44	24.82	24.83
	777	22H	848.31	25.45	25.40	25.41	25.41	24.81	24.79
PCS	25	24E	1851.25	25.46	25.42	25.42	25.42	24.79	24.77
	600	24E	1880	25.48	25.44	25.46	25.46	24.81	24.84
	1175	24E	1908.75	25.49	25.49	25.50	25.47	24.92	24.92

Table 9-3
 Measured P_{limit} for DSI = 6 (Dual Display Cover 0° or 360°) or DSI = 7 (Dual Display Cover 180°)

Band	Channel	Rule Part	Frequency	SO55 [dBm]	SO55 [dBm]	TDSO SO32 [dBm]	TDSO SO32 [dBm]	1x EvDO Rev. 0 [dBm]	1x EvDO Rev. A [dBm]
	F-RC		MHz	RC1	RC3	FCH+SCH	FCH	(RTAP)	(RETAP)
PCS	25	24E	1851.25	24.91	24.93	24.90	24.90	24.86	24.85
	600	24E	1880	24.92	24.95	24.93	24.92	24.90	24.91
	1175	24E	1908.75	24.98	25.00	25.00	24.99	25.00	25.00

FCC ID: ZNFG900VM	PCTEST Proud to be part of element	SAR EVALUATION REPORT	LG	Approved by: Quality Manager
Document S/N: 1M2006040088-01-R1.ZNF	Test Dates: 06/25/20 – 08/05/20	DUT Type: Portable Handset		Page 32 of 159

Table 9-4
Measured P_{limit} for DSI = 5 (Hotspot mode) and/or DSI = 8 (Phablet with grip sensor active)

Band	Channel	Rule Part	Frequency	SO55 [dBm]	SO55 [dBm]	TDSO SO32 [dBm]	TDSO SO32 [dBm]	1x EvDO Rev. 0 [dBm]	1x EvDO Rev. A [dBm]
	F-RC		MHz	RC1	RC3	FCH+SCH	FCH	(RTAP)	(RETAP)
PCS	25	24E	1851.25	22.15	22.17	22.25	22.29	22.31	22.30
	600	24E	1880	22.09	22.12	22.28	22.27	22.36	22.31
	1175	24E	1908.75	22.14	22.11	22.30	22.31	22.34	22.33

Note: RC1 is only applicable for IS-95 compatibility.



Figure 9-2
Power Measurement Setup

9.3 UMTS Conducted Powers

Table 9-5
Measured P_{max}

3GPP Release Version	Mode	3GPP 34.121 Subtest	Cellular Band [dBm]			PCS Band [dBm]			3GPP MPR [dB]
			4132	4183	4233	9262	9400	9538	
99	WCDMA	12.2 kbps RMC	25.29	25.28	25.24	25.19	25.25	25.23	-
99		12.2 kbps AMR	25.26	25.28	25.13	25.22	25.19	25.19	-
6	HSDPA	Subtest 1	25.00	25.14	24.84	24.91	24.77	25.08	0
6		Subtest 2	25.02	24.90	24.95	25.16	24.98	25.17	0
6		Subtest 3	24.39	24.58	24.60	24.64	24.66	24.64	0.5
6		Subtest 4	24.54	24.63	24.60	24.65	24.66	24.67	0.5
6	HSUPA	Subtest 1	24.64	24.69	24.67	25.11	25.20	25.17	0
6		Subtest 2	23.06	23.09	23.10	23.09	23.15	23.10	2
6		Subtest 3	24.03	24.01	24.07	24.11	24.13	24.08	1
6		Subtest 4	23.03	23.10	23.11	23.11	23.16	23.14	2
6		Subtest 5	25.08	25.15	25.12	25.14	25.22	25.17	0

FCC ID: ZNFG900VM	PCTEST Proud to be part of element	SAR EVALUATION REPORT	LG	Approved by: Quality Manager
Document S/N: 1M2006040088-01-R1.ZNF	Test Dates: 06/25/20 – 08/05/20	DUT Type: Portable Handset		Page 33 of 159

Table 9-6
Measured P_{limit} for DSI = 6 (Dual Display Cover 0° or 360°) or DSI = 7 (Dual Display Cover 180°)

3GPP Release Version	Mode	3GPP 34.121 Subtest	PCS Band [dBm]			3GPP MPR [dB]
			9262	9400	9538	
99	WCDMA	12.2 kbps RMC	23.40	23.50	23.48	-
99		12.2 kbps AMR	23.39	23.46	23.47	-
6	HSDPA	Subtest 1	23.15	23.14	23.18	0
6		Subtest 2	23.06	23.04	23.06	0
6		Subtest 3	22.66	22.70	22.70	0.5
6		Subtest 4	22.68	22.70	22.71	0.5
6	HSUPA	Subtest 1	22.64	22.18	22.68	0
6		Subtest 2	21.08	21.62	21.14	2
6		Subtest 3	22.03	21.59	22.09	1
6		Subtest 4	21.12	21.86	21.15	2
6		Subtest 5	23.11	23.17	23.16	0

Table 9-7
Measured P_{limit} for DSI = 5 (Hotspot mode) and/or DSI = 8 (Phablet with grip sensor active)

3GPP Release Version	Mode	3GPP 34.121 Subtest	PCS Band [dBm]			3GPP MPR [dB]
			9262	9400	9538	
99	WCDMA	12.2 kbps RMC	22.05	22.05	22.10	-
99		12.2 kbps AMR	22.00	22.01	22.05	-
6	HSDPA	Subtest 1	21.34	21.10	21.68	0
6		Subtest 2	21.92	21.88	21.80	0
6		Subtest 3	21.43	21.35	21.42	0.5
6		Subtest 4	21.43	21.42	21.43	0.5
6	HSUPA	Subtest 1	20.90	20.94	20.96	0
6		Subtest 2	19.91	19.95	19.93	2
6		Subtest 3	20.91	20.93	20.93	1
6		Subtest 4	19.96	19.96	19.95	2
6		Subtest 5	21.94	21.93	21.92	0

This device does not support DC-HSDPA



Figure 9-3
Power Measurement Setup

FCC ID: ZNFG900VM	 <small>Proud to be part of element</small>	SAR EVALUATION REPORT		Approved by: Quality Manager
Document S/N: 1M2006040088-01-R1.ZNF	Test Dates: 06/25/20 – 08/05/20	DUT Type: Portable Handset	Page 34 of 159	

9.4 LTE Conducted Powers

9.4.1 LTE Band 12

Table 9-8
LTE Band 12 Measured P_{max} - 10 MHz Bandwidth

LTE Band 12 10 MHz Bandwidth					
Modulation	RB Size	RB Offset	Mid Channel	MPR Allowed per 3GPP [dB]	MPR [dB]
			23095 (707.5 MHz)		
			Conducted Power [dBm]		
QPSK	1	0	25.12	0	0
	1	25	25.13		0
	1	49	25.05		0
	25	0	24.11	0-1	1
	25	12	24.16		1
	25	25	24.13		1
	50	0	24.11		1
16QAM	1	0	24.13	0-1	1
	1	25	24.14		1
	1	49	24.10		1
	25	0	23.18	0-2	2
	25	12	23.19		2
	25	25	23.17		2
	50	0	23.06		2
64QAM	1	0	23.47	0-2	2
	1	25	23.46		2
	1	49	23.50		2
	25	0	22.18	0-3	3
	25	12	22.24		3
	25	25	22.23		3
	50	0	22.10		3

Note: LTE Band 12 at 10 MHz bandwidth does not support three non-overlapping channels. Per KDB Publication 941225 D05v02, when a device supports overlapping channel assignment in a channel bandwidth configuration, the middle channel of the group of overlapping channels should be selected for testing.



FCC ID: ZNFG900VM	 PCTEST Proud to be part of 	SAR EVALUATION REPORT		Approved by: Quality Manager
Document S/N: 1M2006040088-01-R1.ZNF	Test Dates: 06/25/20 – 08/05/20	DUT Type: Portable Handset		Page 35 of 159

Table 9-9
LTE Band 12 Measured P_{max} - 5 MHz Bandwidth

LTE Band 12 5 MHz Bandwidth							
Modulation	RB Size	RB Offset	Low Channel	Mid Channel	High Channel	MPR Allowed per 3GPP [dB]	MPR [dB]
			23035 (701.5 MHz)	23095 (707.5 MHz)	23155 (713.5 MHz)		
			Conducted Power [dBm]				
QPSK	1	0	25.17	25.12	25.29	0	0
	1	12	25.20	25.21	25.28		0
	1	24	25.18	25.17	25.22		0
	12	0	24.25	24.25	24.27	0-1	1
	12	6	24.30	24.29	24.32		1
	12	13	24.31	24.26	24.29		1
	25	0	24.25	24.27	24.25		1
16QAM	1	0	24.50	24.45	24.44	0-1	1
	1	12	24.50	24.49	24.47		1
	1	24	24.50	24.50	24.40		1
	12	0	23.37	23.42	23.32	0-2	2
	12	6	23.41	23.40	23.44		2
	12	13	23.36	23.46	23.34		2
	25	0	23.35	23.34	23.21		2
64QAM	1	0	23.24	23.50	23.50	0-2	2
	1	12	23.29	23.50	23.50		2
	1	24	23.24	23.50	23.49		2
	12	0	22.40	22.26	22.32	0-3	3
	12	6	22.46	22.26	22.43		3
	12	13	22.42	22.30	22.37		3
	25	0	22.35	22.27	22.27		3

Table 9-10
LTE Band 12 Measured P_{max} - 3 MHz Bandwidth

LTE Band 12 3 MHz Bandwidth							
Modulation	RB Size	RB Offset	Low Channel	Mid Channel	High Channel	MPR Allowed per 3GPP [dB]	MPR [dB]
			23025 (700.5 MHz)	23095 (707.5 MHz)	23165 (714.5 MHz)		
			Conducted Power [dBm]				
QPSK	1	0	25.25	25.33	25.31	0	0
	1	7	25.14	25.40	25.10		0
	1	14	25.20	25.32	25.06		0
	8	0	24.32	24.32	24.30	0-1	1
	8	4	24.29	24.32	24.37		1
	8	7	24.27	24.40	24.32		1
	15	0	24.28	24.34	24.30		1
16QAM	1	0	24.40	24.27	24.49	0-1	1
	1	7	24.28	24.26	24.50		1
	1	14	24.32	24.26	24.50		1
	8	0	23.40	23.40	23.41	0-2	2
	8	4	23.35	23.45	23.40		2
	8	7	23.34	23.45	23.41		2
	15	0	23.27	23.35	23.35		2
64QAM	1	0	23.50	23.50	23.43	0-2	2
	1	7	23.49	23.50	23.44		2
	1	14	23.49	23.50	23.44		2
	8	0	22.38	22.31	22.38	0-3	3
	8	4	22.43	22.34	22.45		3
	8	7	22.36	22.41	22.39		3
	15	0	22.30	22.45	22.35		3





FCC ID: ZNFG900VM	 PCTEST Proud to be part of element	SAR EVALUATION REPORT	 LG	Approved by: Quality Manager
Document S/N: 1M2006040088-01-R1.ZNF	Test Dates: 06/25/20 – 08/05/20	DUT Type: Portable Handset		Page 36 of 159

Table 9-11
LTE Band 12 Measured P_{max} -1.4 MHz Bandwidth

LTE Band 12 1.4 MHz Bandwidth							
Modulation	RB Size	RB Offset	Low Channel	Mid Channel	High Channel	MPR Allowed per 3GPP [dB]	MPR [dB]
			23017 (699.7 MHz)	23095 (707.5 MHz)	23173 (715.3 MHz)		
			Conducted Power [dBm]				
QPSK	1	0	25.31	25.26	25.12	0	0
	1	2	25.37	25.40	25.17		0
	1	5	25.25	25.24	25.19		0
	3	0	25.24	25.20	25.19		0
	3	2	25.28	25.30	25.22		0
	3	3	25.21	25.26	25.15		0
	6	0	24.28	24.28	24.23	0-1	1
16QAM	1	0	24.50	24.40	24.29	0-1	1
	1	2	24.50	24.49	24.35		1
	1	5	24.50	24.47	24.27		1
	3	0	24.42	24.35	24.42		1
	3	2	24.45	24.44	24.48		1
	3	3	24.40	24.40	24.41		1
	6	0	23.15	23.42	23.43	0-2	2
64QAM	1	0	23.28	23.45	23.49	0-2	2
	1	2	23.44	23.50	23.50		2
	1	5	23.34	23.49	23.49		2
	3	0	23.37	23.17	23.50		2
	3	2	23.45	23.30	23.50		2
	3	3	23.41	23.25	23.50		2
	6	0	22.50	22.30	22.24	0-3	3

FCC ID: ZNFG900VM	 PCTEST Proud to be part of 	SAR EVALUATION REPORT		Approved by: Quality Manager
Document S/N: 1M2006040088-01-R1.ZNF	Test Dates: 06/25/20 – 08/05/20	DUT Type: Portable Handset	Page 37 of 159	

9.4.2

LTE Band 13

Table 9-12
 LTE Band 13 Measured P_{max} - 10 MHz Bandwidth

LTE Band 13 10 MHz Bandwidth					
Modulation	RB Size	RB Offset	Mid Channel	MPR Allowed per 3GPP [dB]	MPR [dB]
			23230 (782.0 MHz)		
			Conducted Power [dBm]		
QPSK	1	0	24.78	0	0
	1	25	24.94		0
	1	49	24.88		0
	25	0	24.10	0-1	1
	25	12	24.17		1
	25	25	24.21		1
	50	0	24.11		1
16QAM	1	0	24.09	0-1	1
	1	25	24.17		1
	1	49	24.23		1
	25	0	23.21	0-2	2
	25	12	23.26		2
	25	25	23.28		2
	50	0	23.09		2
64QAM	1	0	23.44	0-2	2
	1	25	23.47		2
	1	49	23.44		2
	25	0	22.22	0-3	3
	25	12	22.25		3
	25	25	22.25		3
	50	0	22.14		3







FCC ID: ZNFG900VM	 PCTEST Proud to be part of 	SAR EVALUATION REPORT		Approved by: Quality Manager
Document S/N: 1M2006040088-01-R1.ZNF	Test Dates: 06/25/20 – 08/05/20	DUT Type: Portable Handset		Page 38 of 159

Table 9-13
LTE Band 13 Measured P_{max} - 5 MHz Bandwidth

LTE Band 13 5 MHz Bandwidth					
Modulation	RB Size	RB Offset	Mid Channel	MPR Allowed per 3GPP [dB]	MPR [dB]
			23230 (782.0 MHz)		
			Conducted Power [dBm]		
QPSK	1	0	25.21	0	0
	1	12	25.30		0
	1	24	25.38		0
	12	0	24.24	0-1	1
	12	6	24.32		1
	12	13	24.34		1
	25	0	24.30		1
16QAM	1	0	24.39	0-1	1
	1	12	24.47		1
	1	24	24.49		1
	12	0	23.35	0-2	2
	12	6	23.45		2
	12	13	23.45		2
	25	0	23.34		2
64QAM	1	0	22.78	0-2	2
	1	12	22.50		2
	1	24	22.85		2
	12	0	22.20	0-3	3
	12	6	22.21		3
	12	13	22.44		3
	25	0	22.32		3

Note: LTE Band 13 at 5 MHz bandwidth does not support three non-overlapping channels. Per KDB Publication 941225 D05v02, when a device supports overlapping channel assignment in a channel bandwidth configuration, the middle channel of the group of overlapping channels should be selected for testing.

FCC ID: ZNFG900VM	 PCTEST Proud to be part of 	SAR EVALUATION REPORT		Approved by: Quality Manager
Document S/N: 1M2006040088-01-R1.ZNF	Test Dates: 06/25/20 – 08/05/20	DUT Type: Portable Handset		Page 39 of 159

9.4.3

LTE Band 5 (Cell)

Table 9-14
 LTE Band 5 (Cell) Measured P_{max} - 10 MHz Bandwidth

LTE Band 5 (Cell) 10 MHz Bandwidth					
Modulation	RB Size	RB Offset	Mid Channel	MPR Allowed per 3GPP [dB]	MPR [dB]
			20525 (836.5 MHz)		
			Conducted Power [dBm]		
QPSK	1	0	25.30	0	0
	1	25	25.09		0
	1	49	25.10		0
	25	0	24.17	0-1	1
	25	12	24.19		1
	25	25	24.22		1
	50	0	24.08		1
16QAM	1	0	24.48	0-1	1
	1	25	24.47		1
	1	49	24.49		1
	25	0	23.29	0-2	2
	25	12	23.28		2
	25	25	23.31		2
	50	0	23.11		2
64QAM	1	0	23.37	0-2	2
	1	25	23.38		2
	1	49	23.37		2
	25	0	22.32	0-3	3
	25	12	22.30		3
	25	25	22.35		3
	50	0	22.16		3

Note: LTE Band 5 (Cell) at 10 MHz bandwidth does not support three non-overlapping channels. Per KDB Publication 941225 D05v02, when a device supports overlapping channel assignment in a channel bandwidth configuration, the middle channel of the group of overlapping channels should be selected for testing.



FCC ID: ZNFG900VM	 PCTEST Proud to be part of element	SAR EVALUATION REPORT	 LG	Approved by: Quality Manager
Document S/N: 1M2006040088-01-R1.ZNF	Test Dates: 06/25/20 – 08/05/20	DUT Type: Portable Handset	Page 40 of 159	

Table 9-15
LTE Band 5 (Cell) Measured P_{max} - 5 MHz Bandwidth

LTE Band 5 (Cell) 5 MHz Bandwidth							
Modulation	RB Size	RB Offset	Low Channel	Mid Channel	High Channel	MPR Allowed per 3GPP [dB]	MPR [dB]
			20425 (826.5 MHz)	20525 (836.5 MHz)	20625 (846.5 MHz)		
			Conducted Power [dBm]				
QPSK	1	0	25.30	25.14	25.15	0	0
	1	12	25.40	25.25	25.25		0
	1	24	25.32	25.18	25.13		0
	12	0	24.22	24.22	24.24	0-1	1
	12	6	24.30	24.34	24.30		1
	12	13	24.23	24.30	24.31		1
	25	0	24.22	24.28	24.25		1
16QAM	1	0	24.40	24.40	24.50	0-1	1
	1	12	24.45	24.49	24.50		1
	1	24	24.42	24.50	24.50		1
	12	0	23.35	23.34	23.40	0-2	2
	12	6	23.35	23.44	23.45		2
	12	13	23.30	23.43	23.45		2
	25	0	23.30	23.30	23.30		2
64QAM	1	0	23.15	23.49	23.50	0-2	2
	1	12	23.20	23.50	23.25		2
	1	24	23.15	23.50	23.19		2
	12	0	22.27	22.28	22.25	0-3	3
	12	6	22.34	22.30	22.02		3
	12	13	22.30	22.35	21.90		3
	25	0	22.25	22.27	22.13		3

Table 9-16
LTE Band 5 (Cell) Measured P_{max} - 3 MHz Bandwidth

LTE Band 5 (Cell) 3 MHz Bandwidth							
Modulation	RB Size	RB Offset	Low Channel	Mid Channel	High Channel	MPR Allowed per 3GPP [dB]	MPR [dB]
			20415 (825.5 MHz)	20525 (836.5 MHz)	20635 (847.5 MHz)		
			Conducted Power [dBm]				
QPSK	1	0	25.25	25.17	25.22	0	0
	1	7	25.24	25.20	25.27		0
	1	14	25.20	25.22	25.24		0
	8	0	24.29	24.23	24.24	0-1	1
	8	4	24.28	24.34	24.33		1
	8	7	24.23	24.33	24.30		1
	15	0	24.29	24.32	24.25		1
16QAM	1	0	24.50	24.36	24.48	0-1	1
	1	7	24.49	24.34	24.50		1
	1	14	24.50	24.40	24.50		1
	8	0	23.37	23.33	23.30	0-2	2
	8	4	23.41	23.45	23.39		2
	8	7	23.36	23.45	23.35		2
	15	0	23.33	23.35	23.25		2
64QAM	1	0	23.38	23.48	23.21	0-2	2
	1	7	23.40	23.49	23.07		2
	1	14	23.40	23.50	23.24		2
	8	0	22.36	22.38	22.05	0-3	3
	8	4	22.41	22.46	22.05		3
	8	7	22.35	22.45	22.12		3
	15	0	22.35	22.36	22.09		3



FCC ID: ZNFG900VM	 PCTEST Proud to be part of element	SAR EVALUATION REPORT		Approved by: Quality Manager
Document S/N: 1M2006040088-01-R1.ZNF	Test Dates: 06/25/20 – 08/05/20	DUT Type: Portable Handset	Page 41 of 159	

Table 9-17
LTE Band 5 (Cell) Measured P_{max} -1.4 MHz Bandwidth

LTE Band 5 (Cell)							
1.4 MHz Bandwidth							
Modulation	RB Size	RB Offset	Low Channel	Mid Channel	High Channel	MPR Allowed per 3GPP [dB]	MPR [dB]
			20407 (824.7 MHz)	20525 (836.5 MHz)	20643 (848.3 MHz)		
			Conducted Power [dBm]				
QPSK	1	0	25.19	25.09	25.21	0	0
	1	2	25.24	25.22	25.25		0
	1	5	25.15	25.15	25.19		0
	3	0	25.14	25.07	25.13		0
	3	2	25.19	25.20	25.14		0
	3	3	25.12	25.13	25.13		0
	6	0	24.20	24.23	24.18	0-1	1
16QAM	1	0	24.50	24.24	24.33	0-1	1
	1	2	24.50	24.34	24.37		1
	1	5	24.49	24.30	24.32		1
	3	0	24.41	24.37	24.29		1
	3	2	24.40	24.48	24.35		1
	3	3	24.35	24.44	24.25		1
	6	0	23.11	23.41	23.37	0-2	2
64QAM	1	0	23.31	23.40	23.43	0-2	2
	1	2	23.44	23.49	23.49		2
	1	5	23.32	23.50	23.47		2
	3	0	23.34	23.20	23.39		2
	3	2	23.42	23.30	23.50		2
	3	3	23.36	23.29	23.49		2
	6	0	22.49	22.37	22.04	0-3	3

9.4.4 LTE Band 66 (AWS)

Table 9-18
LTE Band 66 (AWS) Measured P_{max} - 20 MHz Bandwidth

LTE Band 66 (AWS)								
20 MHz Bandwidth								
Modulation	RB Size	RB Offset	Low Channel	Mid Channel	High Channel	MPR Allowed per 3GPP [dB]	MPR [dB]	
			132072 (1720.0 MHz)	132322 (1745.0 MHz)	132572 (1770.0 MHz)			
			Conducted Power [dBm]					
QPSK	1	0	24.86	24.81	25.32	0	0	
	1	50	25.10	25.02	25.15		0	
	1	99	24.83	24.82	25.08		0	
		50	0	24.10	24.15	24.18	0-1	1
		50	25	24.19	24.19	24.26		1
		50	50	24.07	24.20	24.13		1
	100	0	24.11	24.14	24.25	1		
16QAM	1	0	24.29	24.41	24.48	0-1	1	
	1	50	24.44	24.48	24.50		1	
	1	99	24.27	24.37	24.49		1	
		50	0	23.10	23.21	23.24	0-2	2
		50	25	23.15	23.22	23.35		2
		50	50	23.09	23.23	23.21		2
	100	0	23.10	23.16	23.19	2		
64QAM	1	0	23.11	23.48	23.45	0-2	2	
	1	50	23.30	23.41	23.48		2	
	1	99	23.06	23.49	23.45		2	
		50	0	22.17	22.23	22.19	0-3	3
		50	25	22.25	22.25	22.38		3
		50	50	22.10	22.24	22.29		3
	100	0	22.15	22.19	22.20	3		



FCC ID: ZNFG900VM	 PCTEST Proud to be part of 	SAR EVALUATION REPORT		Approved by: Quality Manager
Document S/N: 1M2006040088-01-R1.ZNF	Test Dates: 06/25/20 – 08/05/20	DUT Type: Portable Handset	Page 42 of 159	

Table 9-19
LTE Band 66 (AWS) Measured P_{max} - 15 MHz Bandwidth

LTE Band 66 (AWS) 15 MHz Bandwidth							
Modulation	RB Size	RB Offset	Low Channel	Mid Channel	High Channel	MPR Allowed per 3GPP [dB]	MPR [dB]
			132047 (1717.5 MHz)	132322 (1745.0 MHz)	132597 (1772.5 MHz)		
Conducted Power [dBm]							
QPSK	1	0	24.71	24.70	24.95	0	0
	1	36	24.76	24.58	24.85		0
	1	74	24.65	24.51	24.75		0
	36	0	23.83	23.85	23.90	0-1	1
	36	18	23.87	23.84	23.94		1
	36	37	23.81	23.83	23.88		1
75	0	23.84	23.78	23.85	1		
16QAM	1	0	23.82	23.66	24.35	0-1	1
	1	36	23.84	23.80	24.29		1
	1	74	23.70	23.60	24.21		1
	36	0	22.93	22.90	22.97	0-2	2
	36	18	23.01	22.86	23.02		2
	36	37	22.94	22.83	22.92		2
75	0	23.00	22.81	22.87	2		
64QAM	1	0	23.38	23.49	23.50	0-2	2
	1	36	23.42	23.50	23.50		2
	1	74	23.35	23.48	23.50		2
	36	0	22.47	22.50	22.48	0-3	3
	36	18	22.49	22.49	22.50		3
	36	37	22.45	22.48	22.48		3
75	0	22.44	22.45	22.49	3		

Table 9-20
LTE Band 66 (AWS) Measured P_{max} - 10 MHz Bandwidth

LTE Band 66 (AWS) 10 MHz Bandwidth							
Modulation	RB Size	RB Offset	Low Channel	Mid Channel	High Channel	MPR Allowed per 3GPP [dB]	MPR [dB]
			132022 (1715.0 MHz)	132322 (1745.0 MHz)	132622 (1775.0 MHz)		
Conducted Power [dBm]							
QPSK	1	0	24.64	24.61	24.70	0	0
	1	25	24.90	24.85	24.88		0
	1	49	24.64	24.63	24.72		0
	25	0	23.94	23.92	23.93	0-1	1
	25	12	23.96	23.97	23.99		1
	25	25	23.88	23.92	23.93		1
50	0	23.90	23.88	23.88	1		
16QAM	1	0	24.06	23.81	23.69	0-1	1
	1	25	24.28	23.95	23.90		1
	1	49	24.05	23.78	23.70		1
	25	0	22.99	23.03	22.96	0-2	2
	25	12	23.06	23.09	23.00		2
	25	25	22.92	23.03	22.93		2
50	0	22.94	22.92	22.87	2		
64QAM	1	0	23.25	23.30	23.42	0-2	2
	1	25	23.45	23.50	23.50		2
	1	49	23.24	23.35	23.45		2
	25	0	22.45	22.44	22.50	0-3	3
	25	12	22.50	22.48	22.49		3
	25	25	22.42	22.46	22.48		3
50	0	22.40	22.35	22.42	3		



FCC ID: ZNFG900VM	 PCTEST Proud to be part of 	SAR EVALUATION REPORT		Approved by: Quality Manager
Document S/N: 1M2006040088-01-R1.ZNF	Test Dates: 06/25/20 – 08/05/20	DUT Type: Portable Handset	Page 43 of 159	

Table 9-21
LTE Band 66 (AWS) Measured P_{max} - 5 MHz Bandwidth

LTE Band 66 (AWS) 5 MHz Bandwidth							
Modulation	RB Size	RB Offset	Low Channel	Mid Channel	High Channel	MPR Allowed per 3GPP [dB]	MPR [dB]
			131997 (1712.5 MHz)	132322 (1745.0 MHz)	132647 (1777.5 MHz)		
Conducted Power [dBm]							
QPSK	1	0	24.93	24.93	25.05	0	0
	1	12	24.93	24.98	25.02		0
	1	24	24.86	24.92	24.94		0
	12	0	24.00	24.00	24.01	0-1	1
	12	6	24.01	24.00	24.05		1
	12	13	23.96	23.97	23.97		1
16QAM	25	0	23.95	23.98	24.01	0-1	1
	1	0	24.50	24.15	24.22		1
	1	12	24.48	24.17	24.19		1
	1	24	24.43	24.13	24.09	0-2	1
	12	0	23.21	23.04	23.13		2
	12	6	23.15	23.05	23.13		2
64QAM	12	13	23.07	23.00	23.02	0-2	2
	25	0	23.04	22.91	23.05		2
	1	0	23.50	23.50	23.49		0-2
	1	12	23.50	23.50	23.43	2	
	1	24	23.49	23.49	23.33	2	
	64QAM	12	0	22.39	22.49	22.50	0-3
12		6	22.42	22.48	22.50	3	
12		13	22.32	22.49	22.49	3	
25		0	22.37	22.44	22.49	3	

Table 9-22
LTE Band 66 (AWS) Measured P_{max} - 3 MHz Bandwidth

LTE Band 66 (AWS) 3 MHz Bandwidth							
Modulation	RB Size	RB Offset	Low Channel	Mid Channel	High Channel	MPR Allowed per 3GPP [dB]	MPR [dB]
			131987 (1711.5 MHz)	132322 (1745.0 MHz)	132657 (1778.5 MHz)		
Conducted Power [dBm]							
QPSK	1	0	25.01	25.04	25.03	0	0
	1	7	24.90	25.05	24.89		0
	1	14	24.86	24.95	24.89		0
	8	0	24.04	24.04	24.06	0-1	1
	8	4	24.08	24.04	24.05		1
	8	7	24.00	24.00	24.00		1
16QAM	15	0	24.02	24.02	24.05	0-1	1
	1	0	24.03	24.39	24.11		1
	1	7	23.90	24.41	24.02		1
	1	14	23.90	24.36	23.95	0-2	1
	8	0	23.18	23.10	23.13		2
	8	4	23.18	23.18	23.09		2
64QAM	8	7	23.09	23.10	23.03	0-2	2
	15	0	23.10	23.08	23.01		2
	1	0	23.47	23.50	23.50		0-2
	1	7	23.48	23.50	23.48	2	
	1	14	23.48	23.49	23.47	2	
	64QAM	8	0	22.50	22.41	22.50	0-3
8		4	22.49	22.48	22.50	3	
8		7	22.46	22.43	22.48	3	
15		0	22.45	22.50	22.49	3	



FCC ID: ZNFG900VM	 PCTEST Proud to be part of element	SAR EVALUATION REPORT		Approved by: Quality Manager
Document S/N: 1M2006040088-01-R1.ZNF	Test Dates: 06/25/20 – 08/05/20	DUT Type: Portable Handset	Page 44 of 159	

Table 9-23
LTE Band 66 (AWS) Measured P_{max} -1.4 MHz Bandwidth

LTE Band 66 (AWS) 1.4 MHz Bandwidth							
Modulation	RB Size	RB Offset	Low Channel	Mid Channel	High Channel	MPR Allowed per 3GPP [dB]	MPR [dB]
			131979 (1710.7 MHz)	132322 (1745.0 MHz)	132665 (1779.3 MHz)		
Conducted Power [dBm]							
QPSK	1	0	25.13	25.02	25.06	0	0
	1	2	24.90	25.10	25.09		0
	1	5	25.20	25.02	25.04		0
	3	0	24.92	25.03	25.00		0
	3	2	24.93	25.05	25.02		0
	3	3	24.85	25.01	24.97		0
16QAM	6	0	23.96	24.08	24.05	0-1	1
	1	0	24.46	23.87	24.19	0-1	1
	1	2	24.49	23.99	24.29		1
	1	5	24.42	24.10	24.15		1
	3	0	24.30	24.31	24.15		1
	3	2	24.31	24.32	24.18		1
3	3	24.25	24.28	24.12	1		
64QAM	6	0	23.03	23.31	23.19	0-2	2
	1	0	23.45	23.49	23.49	0-2	2
	1	2	23.49	23.48	23.50		2
	1	5	23.42	23.50	23.50		2
	3	0	23.48	23.38	23.48		2
	3	2	23.47	23.39	23.49		2
3	3	23.46	23.35	23.50	2		
	6	0	22.49	22.48	22.44	0-3	3

Table 9-24
LTE Band 66 (AWS) Measured P_{limit} for DSI = 6 (Dual Display Cover 0° or 360°) or DSI = 7 (Dual Display Cover 180°) - 20 MHz Bandwidth

LTE Band 66 (AWS) 20 MHz Bandwidth								
Modulation	RB Size	RB Offset	Low Channel	Mid Channel	High Channel	MPR Allowed per 3GPP [dB]	MPR [dB]	
			132072 (1720.0 MHz)	132322 (1745.0 MHz)	132572 (1770.0 MHz)			
QPSK	1	0	24.69	24.71	25.00	0	0	
	1	50	24.98	24.99	24.98		0	
	1	99	24.78	24.80	24.99		0	
	16QAM	50	0	24.24	24.34	24.40	0-1	0.5
		50	25	24.43	24.44	24.47		0.5
		50	50	24.36	24.38	24.44		0.5
64QAM	100	0	24.39	24.33	24.43	0.5		
	1	0	24.32	24.30	24.49	0-1	0.5	
	1	50	24.48	24.50	24.50		0.5	
	1	99	24.30	24.49	24.50		0.5	
	16QAM	50	0	23.26	23.36	23.33	0-2	1.5
		50	25	23.42	23.42	23.49		1.5
50		50	23.36	23.37	23.45	1.5		
64QAM	100	0	23.35	23.27	23.46	1.5		
	1	0	23.20	23.22	23.49	0-2	1.5	
	1	50	23.42	23.50	23.50		1.5	
	1	99	23.38	23.43	23.50		1.5	
	16QAM	50	0	22.33	22.36	22.42	0-3	2.5
		50	25	22.45	22.40	22.49		2.5
50		50	22.35	22.44	22.46	2.5		
100	0	22.37	22.37	22.45	2.5			



FCC ID: ZNFG900VM	 PCTEST Proud to be part of 	SAR EVALUATION REPORT		Approved by: Quality Manager
Document S/N: 1M2006040088-01-R1.ZNF	Test Dates: 06/25/20 – 08/05/20	DUT Type: Portable Handset		Page 45 of 159

Table 9-25
LTE Band 66 (AWS) Measured P_{limit} for DSI = 6 (Dual Display Cover 0° or 360°) or DSI = 7 (Dual Display Cover 180°) - 15 MHz Bandwidth

LTE Band 66 (AWS) 15 MHz Bandwidth								
Modulation	RB Size	RB Offset	Low Channel	Mid Channel	High Channel	MPR Allowed per 3GPP [dB]	MPR [dB]	
			132047 (1717.5 MHz)	132322 (1745.0 MHz)	132597 (1772.5 MHz)			
			Conducted Power [dBm]					
QPSK	1	0	24.69	24.84	24.98	0	0	
	1	36	24.81	24.94	25.00		0	
	1	74	24.71	24.71	24.98		0	
	QPSK	36	0	24.21	24.33	24.28	0-1	0.5
		36	18	24.29	24.32	24.30		0.5
		36	37	24.25	24.32	24.30		0.5
		75	0	24.24	24.30	24.26		0.5
16QAM	1	0	24.27	24.30	24.50	0-1	0.5	
	1	36	24.39	24.50	24.48		0.5	
	1	74	24.27	24.49	24.45		0.5	
	16QAM	36	0	23.20	23.34	23.31	0-2	1.5
		36	18	23.25	23.34	23.33		1.5
		36	37	23.23	23.36	23.35		1.5
		75	0	23.24	23.33	23.26		1.5
64QAM	1	0	22.94	22.99	23.50	0-2	1.5	
	1	36	23.14	23.27	23.49		1.5	
	1	74	23.02	23.14	23.48		1.5	
	64QAM	36	0	22.34	22.41	22.34	0-3	2.5
		36	18	22.33	22.35	22.32		2.5
		36	37	22.30	22.38	22.35		2.5
		75	0	22.25	22.31	22.33		2.5

Table 9-26
LTE Band 66 (AWS) Measured P_{limit} for DSI = 6 (Dual Display Cover 0° or 360°) or DSI = 7 (Dual Display Cover 180°) - 10 MHz Bandwidth

LTE Band 66 (AWS) 10 MHz Bandwidth								
Modulation	RB Size	RB Offset	Low Channel	Mid Channel	High Channel	MPR Allowed per 3GPP [dB]	MPR [dB]	
			132022 (1715.0 MHz)	132322 (1745.0 MHz)	132622 (1775.0 MHz)			
			Conducted Power [dBm]					
QPSK	1	0	24.54	24.58	24.66	0	0	
	1	25	24.71	24.84	24.94		0	
	1	49	24.55	24.66	24.76		0	
	QPSK	25	0	24.22	24.17	24.23	0-1	0.5
		25	12	24.30	24.27	24.30		0.5
		25	25	24.20	24.24	24.29		0.5
		50	0	24.20	24.17	24.25		0.5
16QAM	1	0	24.28	24.14	24.45	0-1	0.5	
	1	25	24.50	24.40	24.50		0.5	
	1	49	24.34	24.20	24.49		0.5	
	16QAM	25	0	23.35	23.25	23.33	0-2	1.5
		25	12	23.37	23.34	23.40		1.5
		25	25	23.28	23.28	23.36		1.5
		50	0	23.27	23.20	23.27		1.5
64QAM	1	0	23.06	22.81	22.99	0-2	1.5	
	1	25	23.39	23.18	23.33		1.5	
	1	49	23.24	23.01	23.12		1.5	
	64QAM	25	0	22.32	22.28	22.28	0-3	2.5
		25	12	22.35	22.35	22.36		2.5
		25	25	22.29	22.37	22.34		2.5
		50	0	22.26	22.25	22.25		2.5



FCC ID: ZNFG900VM	 <small>Proud to be part of element</small>	SAR EVALUATION REPORT		Approved by: Quality Manager
Document S/N: 1M2006040088-01-R1.ZNF	Test Dates: 06/25/20 – 08/05/20	DUT Type: Portable Handset		Page 46 of 159

Table 9-27
LTE Band 66 (AWS) Measured P_{limit} for DSI = 6 (Dual Display Cover 0° or 360°) or DSI = 7 (Dual Display Cover 180°) - 5 MHz Bandwidth

LTE Band 66 (AWS) 5 MHz Bandwidth							
Modulation	RB Size	RB Offset	Low Channel	Mid Channel	High Channel	MPR Allowed per 3GPP [dB]	MPR [dB]
			131997 (1712.5 MHz)	132322 (1745.0 MHz)	132647 (1777.5 MHz)		
			Conducted Power [dBm]				
QPSK	1	0	24.96	24.88	24.82	0	0
	1	12	24.94	24.99	24.89		0
	1	24	24.86	24.94	24.80		0
	12	0	24.30	24.28	24.37	0-1	0.5
	12	6	24.30	24.30	24.35		0.5
	12	13	24.23	24.29	24.26		0.5
16QAM	25	0	24.29	24.33	24.30	0-1	0.5
	1	0	24.36	24.48	24.50		0.5
	1	12	24.33	24.50	24.47		0.5
	1	24	24.26	24.47	24.49	0-2	0.5
	12	0	23.33	23.50	23.34		1.5
	12	6	23.29	23.49	23.40		1.5
64QAM	12	13	23.26	23.50	23.32	0-2	1.5
	25	0	23.31	23.34	23.39		1.5
	1	0	23.50	23.33	23.42		0-2
	1	12	23.48	23.41	23.38	1.5	
	1	24	23.50	23.36	23.35	1.5	
	64QAM	12	0	22.39	22.35	22.43	0-3
12		6	22.42	22.31	22.42	2.5	
12		13	22.31	22.29	22.35	2.5	
25		0	22.33	22.34	22.35	2.5	

Table 9-28
LTE Band 66 (AWS) Measured P_{limit} for DSI = 6 (Dual Display Cover 0° or 360°) or DSI = 7 (Dual Display Cover 180°) - 3 MHz Bandwidth

LTE Band 66 (AWS) 3 MHz Bandwidth							
Modulation	RB Size	RB Offset	Low Channel	Mid Channel	High Channel	MPR Allowed per 3GPP [dB]	MPR [dB]
			131987 (1711.5 MHz)	132322 (1745.0 MHz)	132657 (1778.5 MHz)		
			Conducted Power [dBm]				
QPSK	1	0	24.92	24.88	24.98	0	0
	1	7	24.80	24.88	24.96		0
	1	14	24.75	24.86	24.92		0
	8	0	24.34	24.28	24.38	0-1	0.5
	8	4	24.27	24.31	24.38		0.5
	8	7	24.24	24.27	24.30		0.5
16QAM	15	0	24.29	24.31	24.36	0-1	0.5
	1	0	24.50	24.45	24.50		0.5
	1	7	24.49	24.43	24.49		0.5
	1	14	24.47	24.39	24.48	0-2	0.5
	8	0	23.47	23.31	23.48		1.5
	8	4	23.43	23.34	23.47		1.5
64QAM	8	7	23.38	23.30	23.44	0-2	1.5
	15	0	23.46	23.29	23.44		1.5
	1	0	23.50	23.21	23.34		0-2
	1	7	23.46	23.14	23.26	1.5	
	1	14	23.44	23.19	23.23	1.5	
	64QAM	8	0	22.35	22.39	22.42	0-3
8		4	22.39	22.42	22.45	2.5	
8		7	22.29	22.39	22.36	2.5	
15		0	22.42	22.45	22.32	2.5	



FCC ID: ZNFG900VM	 PCTEST Proud to be part of 	SAR EVALUATION REPORT		Approved by: Quality Manager
Document S/N: 1M2006040088-01-R1.ZNF	Test Dates: 06/25/20 – 08/05/20	DUT Type: Portable Handset	Page 47 of 159	

Table 9-29
LTE Band 66 (AWS) Measured P_{limit} for DSI = 6 (Dual Display Cover 0° or 360°) or DSI = 7 (Dual Display Cover 180°) – 1.4 MHz Bandwidth

LTE Band 66 (AWS) 1.4 MHz Bandwidth							
Modulation	RB Size	RB Offset	Low Channel	Mid Channel	High Channel	MPR Allowed per 3GPP [dB]	MPR [dB]
			131979 (1710.7 MHz)	132322 (1745.0 MHz)	132665 (1779.3 MHz)		
			Conducted Power [dBm]				
QPSK	1	0	24.78	24.78	24.95	0	0
	1	2	24.82	24.85	24.99		0
	1	5	24.71	24.80	24.93		0
	3	0	24.86	24.79	24.91		0
	3	2	24.86	24.84	24.92		0
	3	3	24.83	24.80	24.85		0
	6	0	24.21	24.21	24.26		0-1
16QAM	1	0	24.46	24.36	24.50	0-1	0.5
	1	2	24.50	24.43	24.49		0.5
	1	5	24.45	24.37	24.49		0.5
	3	0	24.24	24.36	24.42		0.5
	3	2	24.27	24.43	24.47		0.5
	3	3	24.20	24.36	24.36		0.5
	6	0	23.28	23.20	23.36		0-2
64QAM	1	0	23.40	23.09	23.50	0-2	1.5
	1	2	23.43	23.24	23.49		1.5
	1	5	23.35	23.09	23.50		1.5
	3	0	23.34	23.28	23.41		1.5
	3	2	23.37	23.35	23.44		1.5
	3	3	23.29	23.31	23.36		1.5
	6	0	22.28	22.27	22.18		0-3



FCC ID: ZNFG900VM	 PCTEST Proud to be part of 	SAR EVALUATION REPORT		Approved by: Quality Manager
Document S/N: 1M2006040088-01-R1.ZNF	Test Dates: 06/25/20 – 08/05/20	DUT Type: Portable Handset	Page 48 of 159	

Table 9-30
LTE Band 66 (AWS) Measured P_{limit} for DSI = 5 (Hotspot mode) and/or DSI = 8 (Phablet with grip sensor active) - 20 MHz Bandwidth

LTE Band 66 (AWS) 20 MHz Bandwidth							
Modulation	RB Size	RB Offset	Low Channel	Mid Channel	High Channel	MPR Allowed per 3GPP [dB]	MPR [dB]
			132072 (1720.0 MHz)	132322 (1745.0 MHz)	132572 (1770.0 MHz)		
Conducted Power [dBm]							
QPSK	1	0	23.30	23.60	23.96	0	0
	1	50	23.52	23.83	23.91		0
	1	99	23.36	23.67	23.90		0
	50	0	23.75	23.87	23.94	0-1	0
	50	25	23.85	23.93	23.96		0
	50	50	23.75	23.88	23.89		0
16QAM	100	0	23.77	23.81	23.91	0-1	0
	1	0	24.00	24.00	23.99		0
	1	50	23.99	23.99	23.96		0
	1	99	23.98	23.97	23.95	0-2	0
	50	0	23.32	23.38	23.40		0.5
	50	25	23.44	23.42	23.41		0.5
64QAM	50	50	23.32	23.42	23.39	0-2	0.5
	100	0	23.31	23.39	23.34		0.5
	1	0	23.50	23.37	23.49		0.5
	1	50	23.50	23.43	23.50	0-3	0.5
	1	99	23.38	23.50	23.47		0.5
	50	0	22.35	22.44	22.45		1.5
64QAM	50	25	22.43	22.45	22.48	0-3	1.5
	50	50	22.33	22.48	22.45		1.5
	100	0	22.34	22.40	22.42	1.5	

Table 9-31
LTE Band 66 (AWS) Measured P_{limit} for DSI = 5 (Hotspot mode) and/or DSI = 8 (Phablet with grip sensor active) - 15 MHz Bandwidth

LTE Band 66 (AWS) 15 MHz Bandwidth							
Modulation	RB Size	RB Offset	Low Channel	Mid Channel	High Channel	MPR Allowed per 3GPP [dB]	MPR [dB]
			132047 (1717.5 MHz)	132322 (1745.0 MHz)	132597 (1772.5 MHz)		
Conducted Power [dBm]							
QPSK	1	0	23.19	23.57	23.60	0	0
	1	36	23.58	23.85	23.82		0
	1	74	23.35	23.69	23.95		0
	36	0	23.60	23.76	23.40	0-1	0
	36	18	23.80	23.06	23.95		0
	36	37	23.65	23.69	23.79		0
16QAM	75	0	23.58	23.72	23.91	0-1	0
	1	0	24.00	23.55	23.60		0
	1	36	23.55	23.88	23.99		0
	1	74	23.84	23.92	23.92	0-2	0
	36	0	23.43	23.28	23.35		0.5
	36	18	23.42	23.32	23.30		0.5
64QAM	36	37	23.32	23.43	23.48	0-2	0.5
	75	0	23.17	23.34	23.29		0.5
	1	0	23.34	23.49	23.41		0.5
	1	36	23.37	23.38	23.41	0-3	0.5
	1	74	23.39	23.46	23.32		0.5
	36	0	22.39	22.12	22.16		1.5
64QAM	36	18	22.36	22.49	22.13	0-3	1.5
	36	37	22.28	22.50	22.42		1.5
	75	0	22.43	22.30	22.45	1.5	



FCC ID: ZNFG900VM	 PCTEST Proud to be part of 	SAR EVALUATION REPORT		Approved by: Quality Manager
Document S/N: 1M2006040088-01-R1.ZNF	Test Dates: 06/25/20 – 08/05/20	DUT Type: Portable Handset	Page 49 of 159	

Table 9-32
LTE Band 66 (AWS) Measured P_{limit} for DSI = 5 (Hotspot mode) and/or DSI = 8 (Phablet with grip sensor active) - 10 MHz Bandwidth

LTE Band 66 (AWS) 10 MHz Bandwidth							
Modulation	RB Size	RB Offset	Low Channel	Mid Channel	High Channel	MPR Allowed per 3GPP [dB]	MPR [dB]
			132022 (1715.0 MHz)	132322 (1745.0 MHz)	132622 (1775.0 MHz)		
Conducted Power [dBm]							
QPSK	1	0	23.21	23.76	23.53	0	0
	1	25	23.71	23.93	23.76		0
	1	49	23.39	23.77	23.98		0
	25	0	23.65	23.83	23.42	0-1	0
	25	12	23.81	23.33	23.85		0
	25	25	23.84	23.60	23.76		0
16QAM	50	0	23.58	23.53	23.80	0-1	0
	1	0	23.94	23.50	23.50		0
	1	25	23.51	23.86	23.97		0
	1	49	23.93	23.82	23.98	0-2	0
	25	0	23.42	23.37	23.21		0.5
	25	12	23.42	23.27	23.45		0.5
64QAM	25	25	23.37	23.46	23.46	0-2	0.5
	50	0	23.06	23.24	23.30		0.5
	1	0	23.34	23.30	23.41		0.5
	1	25	23.33	23.33	23.32	0-2	0.5
	1	49	23.39	23.34	23.17		0.5
	25	0	22.42	21.97	22.21		0-3
25	12	22.48	22.46	22.02	1.5		
25	25	22.18	22.10	22.29	1.5		
50	0	22.35	22.34	22.47		1.5	

Table 9-33
LTE Band 66 (AWS) Measured P_{limit} for DSI = 5 (Hotspot mode) and/or DSI = 8 (Phablet with grip sensor active) - 5 MHz Bandwidth

LTE Band 66 (AWS) 5 MHz Bandwidth							
Modulation	RB Size	RB Offset	Low Channel	Mid Channel	High Channel	MPR Allowed per 3GPP [dB]	MPR [dB]
			131997 (1712.5 MHz)	132322 (1745.0 MHz)	132647 (1777.5 MHz)		
Conducted Power [dBm]							
QPSK	1	0	23.35	23.78	23.48	0	0
	1	12	23.70	23.69	23.63		0
	1	24	23.36	23.87	23.94		0
	12	0	23.66	23.89	23.34	0-1	0
	12	6	23.80	23.33	23.80		0
	12	13	23.87	23.46	23.79		0
16QAM	25	0	23.46	23.58	23.86	0-1	0
	1	0	23.90	23.53	23.57		0
	1	12	23.65	23.80	23.84		0
	1	24	23.82	23.68	23.99	0-2	0
	12	0	23.49	23.27	23.24		0.5
	12	6	23.16	23.23	23.36		0.5
64QAM	12	13	23.28	23.40	23.15	0-2	0.5
	25	0	22.68	23.15	23.39		0.5
	1	0	23.45	23.24	23.43		0-2
	1	12	23.46	23.25	23.39	0.5	
	1	24	23.26	23.31	23.26	0-3	
	12	0	22.25	22.05	22.07		1.5
12	6	22.36	22.36	22.05	1.5		
12	13	22.04	22.05	22.18		1.5	
25	0	22.28	22.23	22.40		1.5	







FCC ID: ZNFG900VM	 PCTEST Proud to be part of 	SAR EVALUATION REPORT		Approved by: Quality Manager
Document S/N: 1M2006040088-01-R1.ZNF	Test Dates: 06/25/20 – 08/05/20	DUT Type: Portable Handset		Page 50 of 159

Table 9-34
LTE Band 66 (AWS) Measured P_{limit} for DSI = 5 (Hotspot mode) and/or DSI = 8 (Phablet with grip sensor active) - 3 MHz Bandwidth

LTE Band 66 (AWS) 3 MHz Bandwidth							
Modulation	RB Size	RB Offset	Low Channel	Mid Channel	High Channel	MPR Allowed per 3GPP [dB]	MPR [dB]
			131987 (1711.5 MHz)	132322 (1745.0 MHz)	132657 (1778.5 MHz)		
Conducted Power [dBm]							
QPSK	1	0	23.20	23.72	23.47	0	0
	1	7	23.62	23.61	23.55		0
	1	14	23.49	23.91	23.87		0
	8	0	23.61	23.81	23.25	0-1	0
	8	4	23.90	23.35	23.82		0
	8	7	23.83	23.43	23.77		0
16QAM	15	0	23.27	23.51	23.97	0-1	0
	1	0	23.85	23.56	23.58		0
	1	7	23.66	23.94	23.68		0
	8	0	23.47	23.32	23.22	0-2	0.5
	8	4	23.16	23.22	23.30		0.5
	8	7	23.34	23.36	23.20		0.5
64QAM	15	0	22.96	23.25	23.28	0-2	0.5
	1	0	23.40	23.14	23.39		0.5
	1	7	23.42	23.12	23.32		0.5
	8	0	22.26	22.12	22.20	0-3	1.5
	8	4	22.25	22.46	22.08		1.5
	8	7	21.91	21.98	22.23		1.5
	15	0	22.15	22.14	22.50		1.5

Table 9-35
LTE Band 66 (AWS) Measured P_{limit} for DSI = 5 (Hotspot mode) and/or DSI = 8 (Phablet with grip sensor active) - 1.4 MHz Bandwidth

LTE Band 66 (AWS) 1.4 MHz Bandwidth							
Modulation	RB Size	RB Offset	Low Channel	Mid Channel	High Channel	MPR Allowed per 3GPP [dB]	MPR [dB]
			131979 (1710.7 MHz)	132322 (1745.0 MHz)	132665 (1779.3 MHz)		
Conducted Power [dBm]							
QPSK	1	0	23.28	23.78	23.50	0	0
	1	2	23.60	23.49	23.53		0
	1	5	23.33	23.90	23.92		0
	3	0	23.73	23.67	23.50	0-1	0
	3	2	23.97	23.30	23.73		0
	3	3	23.90	23.45	23.75		0
16QAM	6	0	23.33	23.65	23.97	0-1	0
	1	0	23.72	23.60	23.28		0
	1	2	23.73	23.94	23.63		0
	1	5	23.99	23.69	23.81	0-1	0
	3	0	23.51	23.27	23.37		0
	3	2	23.13	23.20	23.27		0
64QAM	3	3	23.26	23.30	23.10	0-2	0.5
	6	0	22.80	23.26	23.11		0.5
	1	0	23.29	22.97	23.16		0.5
	1	2	23.40	23.18	23.28	0-2	0.5
	1	5	23.21	23.15	23.15		0.5
	3	0	23.24	23.22	23.11		0.5
64QAM	3	2	23.34	23.16	23.13	0-2	0.5
	3	3	23.16	23.09	23.24		0.5
	6	0	22.27	22.30	22.16		1.5

FCC ID: ZNFG900VM	 PCTEST Proud to be part of 	SAR EVALUATION REPORT		Approved by: Quality Manager
Document S/N: 1M2006040088-01-R1.ZNF	Test Dates: 06/25/20 – 08/05/20	DUT Type: Portable Handset		Page 51 of 159

9.4.5

LTE Band 2 (PCS)

Table 9-36
LTE Band 2 (PCS) Measured P_{max} - 20 MHz Bandwidth

LTE Band 2 (PCS) 20 MHz Bandwidth							
Modulation	RB Size	RB Offset	Low Channel	Mid Channel	High Channel	MPR Allowed per 3GPP [dB]	MPR [dB]
			18700 (1860.0 MHz)	18900 (1880.0 MHz)	19100 (1900.0 MHz)		
Conducted Power [dBm]							
QPSK	1	0	25.03	25.07	24.88	0	0
	1	50	24.99	25.11	24.87		0
	1	99	25.06	25.19	24.93		0
	50	0	23.97	24.02	24.07	0-1	1
	50	25	24.17	24.18	24.15		1
	50	50	24.14	24.19	24.18		1
100	0	24.11	24.06	24.10	1		
16QAM	1	0	24.49	24.50	24.50	0-1	1
	1	50	24.50	24.48	24.46		1
	1	99	24.49	24.49	24.50		1
	50	0	23.01	23.00	23.09	0-2	2
	50	25	23.18	23.11	23.27		2
	50	50	23.15	23.16	23.21		2
100	0	23.13	23.04	23.09	2		
64QAM	1	0	23.32	23.30	23.44	0-2	2
	1	50	23.40	23.36	23.48		2
	1	99	23.43	23.41	23.50		2
	50	0	22.09	22.08	22.09	0-3	3
	50	25	22.23	22.20	22.30		3
	50	50	22.22	22.23	22.20		3
100	0	22.15	22.10	22.11	3		

Table 9-37
LTE Band 2 (PCS) Measured P_{max} - 15 MHz Bandwidth

LTE Band 2 (PCS) 15 MHz Bandwidth							
Modulation	RB Size	RB Offset	Low Channel	Mid Channel	High Channel	MPR Allowed per 3GPP [dB]	MPR [dB]
			18675 (1857.5 MHz)	18900 (1880.0 MHz)	19125 (1902.5 MHz)		
Conducted Power [dBm]							
QPSK	1	0	24.83	24.99	25.09	0	0
	1	36	24.90	24.95	25.07		0
	1	74	24.90	24.96	25.05		0
	36	0	23.87	23.92	23.99	0-1	1
	36	18	24.00	23.95	24.13		1
	36	37	23.98	24.07	24.14		1
75	0	23.94	24.04	24.01	1		
16QAM	1	0	24.34	24.00	24.49	0-1	1
	1	36	24.37	23.98	24.45		1
	1	74	24.35	23.99	24.42		1
	36	0	22.85	22.95	23.03	0-2	2
	36	18	22.97	23.01	23.17		2
	36	37	22.98	23.06	23.15		2
75	0	22.97	23.05	23.01	2		
64QAM	1	0	23.04	23.36	22.59	0-2	2
	1	36	23.16	23.37	22.63		2
	1	74	23.17	23.40	22.63		2
	36	0	22.12	22.05	22.07	0-3	3
	36	18	22.21	22.13	22.21		3
	36	37	22.22	22.18	22.20		3
75	0	22.17	22.14	22.11	3		



FCC ID: ZNFG900VM	 PCTEST Proud to be part of 	SAR EVALUATION REPORT		Approved by: Quality Manager
Document S/N: 1M2006040088-01-R1.ZNF	Test Dates: 06/25/20 – 08/05/20	DUT Type: Portable Handset		Page 52 of 159

Table 9-38
LTE Band 2 (PCS) Measured P_{max} - 10 MHz Bandwidth

LTE Band 2 (PCS) 10 MHz Bandwidth							
Modulation	RB Size	RB Offset	Low Channel	Mid Channel	High Channel	MPR Allowed per 3GPP [dB]	MPR [dB]
			18650 (1855.0 MHz)	18900 (1880.0 MHz)	19150 (1905.0 MHz)		
			Conducted Power [dBm]				
QPSK	1	0	24.67	24.73	25.06	0	0
	1	25	24.97	25.08	25.02		0
	1	49	24.68	24.82	25.04		0
	25	0	23.95	23.95	24.03	0-1	1
	25	12	24.04	24.03	24.12		1
	25	25	23.90	24.01	24.05		1
16QAM	50	0	23.96	24.05	24.00	0-1	1
	1	0	24.08	24.09	24.22		1
	1	25	24.38	24.47	24.14		1
	1	49	24.13	24.23	24.13	0-2	1
	25	0	23.00	23.00	23.12		2
	25	12	23.11	23.08	23.20		2
64QAM	25	25	23.00	23.05	23.19	0-2	2
	50	0	22.98	23.05	23.06		2
	1	0	23.04	22.94	23.48		2
	1	25	23.30	23.30	23.49	0-2	2
	1	49	23.11	23.03	23.50		2
	25	0	22.27	22.20	22.16		0-3
25	12	22.37	22.23	22.27	3		
25	25	22.11	22.26	22.20	3		
50	0	22.09	22.17	22.10		3	

Table 9-39
LTE Band 2 (PCS) Measured P_{max} - 5 MHz Bandwidth

LTE Band 2 (PCS) 5 MHz Bandwidth							
Modulation	RB Size	RB Offset	Low Channel	Mid Channel	High Channel	MPR Allowed per 3GPP [dB]	MPR [dB]
			18625 (1852.5 MHz)	18900 (1880.0 MHz)	19175 (1907.5 MHz)		
			Conducted Power [dBm]				
QPSK	1	0	24.93	25.00	24.82	0	0
	1	12	24.96	25.08	25.08		0
	1	24	24.83	25.01	24.78		0
	12	0	24.05	24.12	23.92	0-1	1
	12	6	24.07	24.13	23.89		1
	12	13	23.97	24.07	24.19		1
16QAM	25	0	24.03	24.13	24.27	0-1	1
	1	0	24.49	24.22	24.50		1
	1	12	24.50	24.32	24.50		1
	1	24	24.48	24.22	24.49	0-2	1
	12	0	23.23	23.18	23.40		2
	12	6	23.24	23.19	23.43		2
64QAM	12	13	23.13	23.17	23.36	0-2	2
	25	0	23.11	23.07	23.30		2
	1	0	23.24	23.11	23.50		2
	1	12	23.30	22.89	23.49	0-2	2
	1	24	23.41	22.80	23.44		2
	12	0	22.38	22.27	22.23		0-3
12	6	22.37	22.31	22.29	3		
12	13	22.29	22.25	22.21	3		
25	0	22.26	22.24	22.22		3	



FCC ID: ZNFG900VM	 PCTEST Proud to be part of 	SAR EVALUATION REPORT		Approved by: Quality Manager
Document S/N: 1M2006040088-01-R1.ZNF	Test Dates: 06/25/20 – 08/05/20	DUT Type: Portable Handset		Page 53 of 159

Table 9-40
LTE Band 2 (PCS) Measured P_{max} - 3 MHz Bandwidth

LTE Band 2 (PCS) 3 MHz Bandwidth							
Modulation	RB Size	RB Offset	Low Channel	Mid Channel	High Channel	MPR Allowed per 3GPP [dB]	MPR [dB]
			18615 (1851.5 MHz)	18900 (1880.0 MHz)	19185 (1908.5 MHz)		
			Conducted Power [dBm]				
QPSK	1	0	25.27	25.14	25.23	0	0
	1	7	25.20	25.15	25.24		0
	1	14	25.28	25.10	25.11		0
	8	0	24.33	24.21	24.25	0-1	1
	8	4	24.29	24.24	24.30		1
	8	7	24.21	24.19	24.24		1
	15	0	24.30	24.29	24.28		1
16QAM	1	0	24.37	24.18	24.50	0-1	1
	1	7	24.26	24.19	24.49		1
	1	14	24.25	24.11	24.49		1
	8	0	23.35	23.32	23.35	0-2	2
	8	4	23.38	23.41	23.34		2
	8	7	23.33	23.36	23.28		2
	15	0	23.27	23.32	23.27		2
64QAM	1	0	23.50	23.49	23.40	0-2	2
	1	7	23.48	23.50	23.36		2
	1	14	23.44	23.49	23.35		2
	8	0	22.31	22.28	22.37	0-3	3
	8	4	22.34	22.38	22.35		3
	8	7	22.26	22.29	22.27		3
	15	0	22.35	22.30	22.29		3

Table 9-41
LTE Band 2 (PCS) Measured P_{max} - 1.4 MHz Bandwidth

LTE Band 2 (PCS) 1.4 MHz Bandwidth							
Modulation	RB Size	RB Offset	Low Channel	Mid Channel	High Channel	MPR Allowed per 3GPP [dB]	MPR [dB]
			18607 (1850.7 MHz)	18900 (1880.0 MHz)	19193 (1909.3 MHz)		
			Conducted Power [dBm]				
QPSK	1	0	25.19	25.19	25.18	0	0
	1	2	25.29	25.21	25.20		0
	1	5	25.14	25.12	25.12		0
	3	0	25.21	25.11	25.17		0
	3	2	25.20	25.17	25.19		0
	3	3	25.16	25.10	25.13		0
	6	0	24.20	24.17	24.15	0-1	1
16QAM	1	0	24.26	24.12	24.48	0-1	1
	1	2	24.30	24.38	24.50		1
	1	5	24.27	24.28	24.49		1
	3	0	24.41	24.23	24.39		1
	3	2	24.46	24.27	24.41		1
	3	3	24.37	24.23	24.31		1
	6	0	23.40	23.33	23.10	0-2	2
64QAM	1	0	23.44	23.49	23.33	0-2	2
	1	2	23.48	23.50	23.38		2
	1	5	23.42	23.48	23.26		2
	3	0	23.20	23.49	23.34		2
	3	2	23.24	23.50	23.39		2
	3	3	23.20	23.49	23.32		2
	6	0	22.31	22.21	22.50	0-3	3



FCC ID: ZNFG900VM	 PCTEST Proud to be part of 	SAR EVALUATION REPORT		Approved by: Quality Manager
Document S/N: 1M2006040088-01-R1.ZNF	Test Dates: 06/25/20 – 08/05/20	DUT Type: Portable Handset		Page 54 of 159

Table 9-42
LTE Band 2 (PCS) Measured P_{limit} for DSI = 6 (Dual Display Cover 0° or 360°) or DSI = 7 (Dual Display Cover 180°) - 20 MHz Bandwidth

LTE Band 2 (PCS) 20 MHz Bandwidth							
Modulation	RB Size	RB Offset	Low Channel	Mid Channel	High Channel	MPR Allowed per 3GPP [dB]	MPR [dB]
			18700 (1860.0 MHz)	18900 (1880.0 MHz)	19100 (1900.0 MHz)		
			Conducted Power [dBm]				
QPSK	1	0	24.92	24.97	24.97	0	0
	1	50	24.99	24.96	24.95		0
	1	99	24.96	24.95	24.94		0
	50	0	24.13	24.17	24.16	0-1	0.5
	50	25	24.33	24.28	24.32		0.5
	50	50	24.40	24.34	24.23		0.5
	100	0	24.38	24.22	24.18	0.5	
16QAM	1	0	24.50	24.50	24.50	0-1	0.5
	1	50	24.48	24.49	24.44		0.5
	1	99	24.47	24.50	24.49		0.5
	50	0	23.18	23.14	23.09	0-2	1.5
	50	25	23.33	23.28	23.30		1.5
	50	50	23.25	23.36	23.27		1.5
	100	0	23.26	23.22	23.23	1.5	
64QAM	1	0	23.42	23.42	23.39	0-2	1.5
	1	50	23.48	23.49	23.45		1.5
	1	99	23.49	23.50	23.43		1.5
	50	0	22.18	22.21	22.15	0-3	2.5
	50	25	22.35	22.31	22.34		2.5
	50	50	22.32	22.35	22.31		2.5
	100	0	22.25	22.19	22.15	2.5	

Table 9-43
LTE Band 2 (PCS) Measured P_{limit} for DSI = 6 (Dual Display Cover 0° or 360°) or DSI = 7 (Dual Display Cover 180°) - 15 MHz Bandwidth

LTE Band 2 (PCS) 15 MHz Bandwidth							
Modulation	RB Size	RB Offset	Low Channel	Mid Channel	High Channel	MPR Allowed per 3GPP [dB]	MPR [dB]
			18675 (1857.5 MHz)	18900 (1880.0 MHz)	19125 (1902.5 MHz)		
			Conducted Power [dBm]				
QPSK	1	0	24.56	24.79	24.90	0	0
	1	36	24.80	24.81	24.91		0
	1	74	24.77	24.81	24.93		0
	36	0	24.02	24.13	24.00	0-1	0.5
	36	18	24.12	24.12	24.09		0.5
	36	37	24.13	24.21	24.13		0.5
	75	0	24.11	24.05	24.09	0.5	
16QAM	1	0	24.08	24.48	24.44	0-1	0.5
	1	36	24.23	24.50	24.45		0.5
	1	74	24.24	24.45	24.44		0.5
	36	0	23.01	23.22	23.03	0-2	1.5
	36	18	23.10	23.13	23.10		1.5
	36	37	23.15	23.21	23.16		1.5
	75	0	23.12	23.10	23.12	1.5	
64QAM	1	0	22.79	23.07	23.49	0-2	1.5
	1	36	22.90	23.10	23.50		1.5
	1	74	22.93	23.16	23.50		1.5
	36	0	22.19	22.08	22.07	0-3	2.5
	36	18	22.25	22.13	22.13		2.5
	36	37	22.24	22.27	22.16		2.5
	75	0	22.15	22.18	22.15	2.5	



FCC ID: ZNFG900VM	 <small>Proud to be part of element</small>	SAR EVALUATION REPORT		Approved by: Quality Manager
Document S/N: 1M2006040088-01-R1.ZNF	Test Dates: 06/25/20 – 08/05/20	DUT Type: Portable Handset		Page 55 of 159

Table 9-44
LTE Band 2 (PCS) Measured P_{limit} for DSI = 6 (Dual Display Cover 0° or 360°) or DSI = 7 (Dual Display Cover 180°) - 10 MHz Bandwidth

LTE Band 2 (PCS) 10 MHz Bandwidth							
Modulation	RB Size	RB Offset	Low Channel	Mid Channel	High Channel	MPR Allowed per 3GPP [dB]	MPR [dB]
			18650 (1855.0 MHz)	18900 (1880.0 MHz)	19150 (1905.0 MHz)		
			Conducted Power [dBm]				
QPSK	1	0	24.52	24.58	24.92	0	0
	1	25	24.77	24.88	24.93		0
	1	49	24.60	24.70	24.94		0
	25	0	24.12	24.06	24.06	0-1	0.5
	25	12	24.17	24.19	24.12		0.5
	25	25	24.10	24.17	24.11		0.5
16QAM	50	0	24.10	24.07	24.07	0-1	0.5
	1	0	24.18	24.00	24.50		0.5
	1	25	24.46	24.34	24.48		0.5
	1	49	24.23	24.13	24.49	0-2	0.5
	25	0	23.31	23.14	23.15		1.5
	25	12	23.28	23.26	23.21		1.5
64QAM	25	25	23.17	23.21	23.19	0-2	1.5
	50	0	23.12	23.10	23.06		1.5
	1	0	23.00	22.74	23.18		0-2
	1	25	23.39	23.18	23.23	1.5	
	1	49	23.19	22.93	23.23	1.5	
	64QAM	25	0	22.19	22.18	22.19	0-3
25		12	22.25	22.27	22.16	2.5	
25		25	22.18	22.24	22.18	2.5	
50		0	22.15	22.18	22.05	2.5	

Table 9-45
LTE Band 2 (PCS) Measured P_{limit} for DSI = 6 (Dual Display Cover 0° or 360°) or DSI = 7 (Dual Display Cover 180°) - 5 MHz Bandwidth

LTE Band 2 (PCS) 5 MHz Bandwidth								
Modulation	RB Size	RB Offset	Low Channel	Mid Channel	High Channel	MPR Allowed per 3GPP [dB]	MPR [dB]	
			18625 (1852.5 MHz)	18900 (1880.0 MHz)	19175 (1907.5 MHz)			
			Conducted Power [dBm]					
QPSK	1	0	24.75	24.73	24.90	0	0	
	1	12	24.78	24.85	24.91		0	
	1	24	24.69	24.76	24.85		0	
	12	0	24.11	24.17	24.26	0-1	0.5	
	12	6	24.01	24.18	24.24		0.5	
	12	13	23.91	24.04	24.22		0.5	
16QAM	25	0	23.98	24.14	24.17	0-1	0.5	
	1	0	24.11	24.36	24.24		0-1	0.5
	1	12	24.31	24.49	24.30			0.5
	1	24	24.26	24.46	24.18	0-2		0.5
	12	0	23.24	23.20	23.19		1.5	
	12	6	23.25	23.22	23.11		1.5	
64QAM	12	13	23.15	23.17	23.12	0-2	1.5	
	25	0	23.02	22.90	23.17		1.5	
	1	0	23.20	23.03	23.40		0-2	1.5
	1	12	23.22	23.14	23.43	1.5		
	1	24	23.11	23.07	23.37	1.5		
	64QAM	12	0	22.07	22.06	22.30	0-3	2.5
12		6	22.11	22.13	22.25	2.5		
12		13	22.05	22.07	22.17	2.5		
25		0	22.14	21.97	22.19	2.5		



FCC ID: ZNFG900VM	 Proud to be part of 	SAR EVALUATION REPORT		Approved by: Quality Manager
Document S/N: 1M2006040088-01-R1.ZNF	Test Dates: 06/25/20 – 08/05/20	DUT Type: Portable Handset		Page 56 of 159

Table 9-46
LTE Band 2 (PCS) Measured P_{limit} for DSI = 6 (Dual Display Cover 0° or 360°) or DSI = 7 (Dual Display Cover 180°) - 3 MHz Bandwidth

LTE Band 2 (PCS) 3 MHz Bandwidth							
Modulation	RB Size	RB Offset	Low Channel	Mid Channel	High Channel	MPR Allowed per 3GPP [dB]	MPR [dB]
			18615 (1851.5 MHz)	18900 (1880.0 MHz)	19185 (1908.5 MHz)		
			Conducted Power [dBm]				
QPSK	1	0	24.90	24.92	24.88	0	0
	1	7	24.89	24.91	24.84		0
	1	14	24.79	24.88	24.80		0
	8	0	24.13	24.19	24.14	0-1	0.5
	8	4	24.14	24.21	24.12		0.5
	8	7	24.07	24.15	24.07		0.5
16QAM	15	0	24.12	24.13	24.11	0-1	0.5
	1	0	24.50	24.50	24.35		0.5
	1	7	24.45	24.48	24.29		0.5
	1	14	24.48	24.46	24.26	0-2	0.5
	8	0	23.26	23.28	23.21		1.5
	8	4	23.27	23.32	23.24		1.5
64QAM	8	7	23.25	23.26	23.19	0-2	1.5
	15	0	23.23	23.17	23.12		1.5
	1	0	23.14	23.12	23.13		0-2
	1	7	23.10	23.14	23.01	1.5	
	1	14	23.02	23.15	23.02	1.5	
	64QAM	8	0	22.21	22.24	22.24	0-3
8		4	22.22	22.29	22.15	2.5	
8		7	22.19	22.26	22.09	2.5	
15		0	22.15	22.09	22.19	2.5	

Table 9-47
LTE Band 2 (PCS) Measured P_{limit} for DSI = 6 (Dual Display Cover 0° or 360°) or DSI = 7 (Dual Display Cover 180°) - 1.4 MHz Bandwidth

LTE Band 2 (PCS) 1.4 MHz Bandwidth								
Modulation	RB Size	RB Offset	Low Channel	Mid Channel	High Channel	MPR Allowed per 3GPP [dB]	MPR [dB]	
			18607 (1850.7 MHz)	18900 (1880.0 MHz)	19193 (1909.3 MHz)			
			Conducted Power [dBm]					
QPSK	1	0	24.95	25.00	24.83	0	0	
	1	2	24.99	24.99	24.87		0	
	1	5	24.95	24.97	24.78		0	
	3	0	24.87	24.90	24.86	0-1	0	
	3	2	24.90	24.94	24.86		0	
	3	3	24.85	24.89	24.82		0	
16QAM	6	0	24.14	24.16	24.08	0-1	0.5	
	1	0	24.45	24.46	24.25		0-1	0.5
	1	2	24.50	24.50	24.30			0.5
	1	5	24.40	24.46	24.22	0.5		
	3	0	24.32	24.35	24.25	0-2	0.5	
	3	2	24.36	24.40	24.30		0.5	
3	3	24.32	24.31	24.22	0.5			
64QAM	6	0	23.25	23.30	23.08	0-2	1.5	
	1	0	23.48	23.33	23.00		0-2	1.5
	1	2	23.50	23.38	23.12			1.5
	1	5	23.50	23.29	22.93	0-2		1.5
	3	0	23.33	23.22	23.16		1.5	
	3	2	23.33	23.28	23.24		1.5	
64QAM	3	3	23.30	23.20	23.16	0-3	1.5	
	6	0	22.06	22.20	22.15		2.5	



FCC ID: ZNFG900VM	 PCTEST Proud to be part of 	SAR EVALUATION REPORT		Approved by: Quality Manager
Document S/N: 1M2006040088-01-R1.ZNF	Test Dates: 06/25/20 – 08/05/20	DUT Type: Portable Handset	Page 57 of 159	

Table 9-48
LTE Band 2 (PCS) Measured P_{limit} for DSI = 5 (Hotspot mode) and/or DSI = 8 (Phablet with grip sensor active) - 20 MHz Bandwidth

LTE Band 2 (PCS) 20 MHz Bandwidth							
Modulation	RB Size	RB Offset	Low Channel	Mid Channel	High Channel	MPR Allowed per 3GPP [dB]	MPR [dB]
			18700 (1860.0 MHz)	18900 (1880.0 MHz)	19100 (1900.0 MHz)		
			Conducted Power [dBm]				
QPSK	1	0	22.22	22.61	22.24	0	0
	1	50	22.10	22.28	22.24		0
	1	99	22.24	22.29	22.31		0
	50	0	22.15	22.29	22.20	0-1	0
	50	25	22.32	22.34	22.32		0
	50	50	22.32	22.60	22.39		0
	100	0	22.32	22.26	22.24	0	
16QAM	1	0	22.68	22.48	22.72	0-1	0
	1	50	22.49	22.50	22.65		0
	1	99	22.58	22.44	22.51		0
	50	0	22.16	22.24	22.19	0-2	0
	50	25	22.47	22.33	22.39		0
	50	50	22.35	22.40	22.40		0
	100	0	22.36	22.21	22.37	0	
64QAM	1	0	22.52	22.23	22.55	0-2	0
	1	50	22.67	22.46	22.62		0
	1	99	22.48	22.48	22.60		0
	50	0	22.12	22.15	22.14	0-3	0.5
	50	25	22.36	22.27	22.17		0.5
	50	50	22.24	22.33	22.35		0.5
	100	0	22.20	22.17	22.14	0.5	



FCC ID: ZNFG900VM	 PCTEST Proud to be part of 	SAR EVALUATION REPORT		Approved by: Quality Manager
Document S/N: 1M2006040088-01-R1.ZNF	Test Dates: 06/25/20 – 08/05/20	DUT Type: Portable Handset	Page 58 of 159	

Table 9-49
LTE Band 2 (PCS) Measured P_{limit} for DSI = 5 (Hotspot mode) and/or DSI = 8 (Phablet with grip sensor active) - 15 MHz Bandwidth

LTE Band 2 (PCS) 15 MHz Bandwidth								
Modulation	RB Size	RB Offset	Low Channel	Mid Channel	High Channel	MPR Allowed per 3GPP [dB]	MPR [dB]	
			18675 (1857.5 MHz)	18900 (1880.0 MHz)	19125 (1902.5 MHz)			
Conducted Power [dBm]								
QPSK	1	0	21.78	21.90	21.92	0	0	
	1	36	21.88	21.89	21.87		0	
	1	74	21.83	21.92	21.91		0	
	QPSK	36	0	21.90	21.90	21.89	0-1	0
		36	18	22.04	21.97	21.97		0
		36	37	22.01	22.05	22.03		0
		75	0	22.03	21.95	21.90		0
1		0	22.09	22.21	22.42	0		
16QAM	1	36	22.24	22.23	22.48	0-1	0	
	1	74	22.22	22.26	22.25		0	
	36	0	21.88	21.98	21.94		0	
	16QAM	36	18	22.05	21.97	21.98	0-2	0
		36	37	22.08	22.09	22.05		0
		75	0	22.03	21.95	21.93		0
		1	0	21.98	22.19	22.13		0
64QAM	1	36	22.18	22.21	22.21	0-2	0	
	1	74	22.16	22.22	22.20		0	
	36	0	21.95	21.96	21.95		0.5	
	64QAM	36	18	22.07	22.03	22.02	0-3	0.5
		36	37	22.10	22.13	22.09		0.5
		75	0	22.04	21.94	21.96		0.5

Table 9-50
LTE Band 2 (PCS) Measured P_{limit} for DSI = 5 (Hotspot mode) and/or DSI = 8 (Phablet with grip sensor active) - 10 MHz Bandwidth

LTE Band 2 (PCS) 10 MHz Bandwidth								
Modulation	RB Size	RB Offset	Low Channel	Mid Channel	High Channel	MPR Allowed per 3GPP [dB]	MPR [dB]	
			18650 (1855.0 MHz)	18900 (1880.0 MHz)	19150 (1905.0 MHz)			
Conducted Power [dBm]								
QPSK	1	0	21.71	21.69	21.98	0	0	
	1	25	21.98	22.03	21.96		0	
	1	49	21.74	21.79	21.92		0	
	QPSK	25	0	22.04	21.98	21.94	0-1	0
		25	12	22.15	22.08	22.01		0
		25	25	21.99	22.04	21.98		0
		50	0	22.04	21.97	21.93		0
16QAM	1	0	22.11	22.11	22.53	0-1	0	
	1	25	22.41	22.47	22.37		0	
	1	49	22.21	22.16	22.41		0	
	16QAM	25	0	22.05	21.96	21.92	0-2	0
		25	12	22.14	22.07	22.01		0
		25	25	22.02	22.06	21.95		0
64QAM	50	0	22.09	22.01	21.95	0		
	1	0	21.98	21.89	22.24	0-2	0	
	1	25	22.23	22.30	22.21		0	
	1	49	22.04	22.02	22.26		0	
	64QAM	25	0	22.10	21.99	21.95	0-3	0.5
		25	12	22.19	22.12	22.03		0.5
		25	25	22.01	22.08	21.99		0.5
50		0	22.05	22.00	21.93	0.5		



FCC ID: ZNFG900VM	 PCTEST Proud to be part of 	SAR EVALUATION REPORT		Approved by: Quality Manager
Document S/N: 1M2006040088-01-R1.ZNF	Test Dates: 06/25/20 – 08/05/20	DUT Type: Portable Handset	Page 59 of 159	

Table 9-51
LTE Band 2 (PCS) Measured P_{limit} for DSI = 5 (Hotspot mode) and/or DSI = 8 (Phablet with grip sensor active) - 5 MHz Bandwidth

LTE Band 2 (PCS) 5 MHz Bandwidth							
Modulation	RB Size	RB Offset	Low Channel	Mid Channel	High Channel	MPR Allowed per 3GPP [dB]	MPR [dB]
			18625 (1852.5 MHz)	18900 (1880.0 MHz)	19175 (1907.5 MHz)		
Conducted Power [dBm]							
QPSK	1	0	22.04	21.97	21.93	0	0
	1	12	22.08	22.12	21.98		0
	1	24	21.90	21.93	21.88		0
	12	0	22.13	22.09	22.08	0-1	0
	12	6	22.16	22.13	22.10		0
	12	13	22.04	22.09	22.05		0
16QAM	25	0	22.08	22.08	22.07	0-1	0
	1	0	22.35	22.34	22.31		0
	1	12	22.38	22.42	22.34		0
	1	24	22.26	22.36	22.17	0-2	0
	12	0	22.19	22.20	22.15		0
	12	6	22.21	22.18	22.18		0
64QAM	12	13	22.09	22.16	22.05	0-2	0
	25	0	22.13	22.12	22.07		0
	1	0	22.24	22.21	22.16		0-3
	1	12	22.33	22.34	22.21	0	
	1	24	22.17	22.18	22.14	0	
	12	0	22.18	22.16	22.16	0-3	0.5
12	6	22.23	22.20	22.15	0.5		
12	13	22.13	22.12	22.05	0.5		
	25	0	22.12	22.06	22.07		0.5

Table 9-52
LTE Band 2 (PCS) Measured P_{limit} for DSI = 5 (Hotspot mode) and/or DSI = 8 (Phablet with grip sensor active) - 3 MHz Bandwidth

LTE Band 2 (PCS) 3 MHz Bandwidth							
Modulation	RB Size	RB Offset	Low Channel	Mid Channel	High Channel	MPR Allowed per 3GPP [dB]	MPR [dB]
			18615 (1851.5 MHz)	18900 (1880.0 MHz)	19185 (1908.5 MHz)		
Conducted Power [dBm]							
QPSK	1	0	22.08	22.06	22.03	0	0
	1	7	22.01	22.10	21.97		0
	1	14	21.99	22.01	21.88		0
	8	0	22.17	22.09	22.06	0-1	0
	8	4	22.17	22.21	22.11		0
	8	7	22.09	22.08	22.02		0
16QAM	15	0	22.11	22.08	22.09	0-1	0
	1	0	22.41	22.42	22.40		0
	1	7	22.29	22.38	22.33		0-2
	1	14	22.34	22.39	22.24	0	
	8	0	22.30	22.20	22.21	0	
	64QAM	8	4	22.21	22.26	22.16	0-2
8		7	22.22	22.20	22.10	0	
15		0	22.15	22.13	22.08	0	
1		0	22.34	22.26	22.22	0-2	0
1		7	22.30	22.32	22.25		0
1		14	22.25	22.29	22.16		0-3
8	0	22.19	22.12	22.13	0.5		
8	4	22.22	22.26	22.11	0.5		
	8	7	22.15	22.12	22.03		0.5
	15	0	22.19	22.15	22.09		0.5







FCC ID: ZNFG900VM	 PCTEST Proud to be part of 	SAR EVALUATION REPORT		Approved by: Quality Manager
Document S/N: 1M2006040088-01-R1.ZNF	Test Dates: 06/25/20 – 08/05/20	DUT Type: Portable Handset		Page 60 of 159

Table 9-53
LTE Band 2 (PCS) Measured P_{limit} for DSI = 5 (Hotspot mode) and/or DSI = 8 (Phablet with grip sensor active) - 1.4 MHz Bandwidth

LTE Band 2 (PCS) 1.4 MHz Bandwidth							
Modulation	RB Size	RB Offset	Low Channel	Mid Channel	High Channel	MPR Allowed per 3GPP [dB]	MPR [dB]
			18607 (1850.7 MHz)	18900 (1880.0 MHz)	19193 (1909.3 MHz)		
			Conducted Power [dBm]				
QPSK	1	0	21.95	22.04	21.86	0	0
	1	2	22.07	22.02	21.89		0
	1	5	21.96	21.93	21.77		0
	3	0	21.93	21.98	21.86		0
	3	2	21.99	21.99	21.88		0
	3	3	21.90	21.93	21.84		0
	6	0	22.05	22.04	21.95		0
16QAM	1	0	22.33	22.31	22.23	0-1	0
	1	2	22.40	22.42	22.27		0
	1	5	22.23	22.30	22.17		0
	3	0	22.18	22.14	22.05		0
	3	2	22.19	22.20	22.13		0
	3	3	22.16	22.12	22.04		0
	6	0	22.12	22.10	21.99		0
64QAM	1	0	22.25	22.24	22.13	0-2	0
	1	2	22.30	22.29	22.21		0
	1	5	22.14	22.16	22.06		0
	3	0	22.08	22.17	22.07		0
	3	2	22.18	22.18	22.05		0
	3	3	22.10	22.12	22.07		0
	6	0	22.08	22.06	21.98		0.5

FCC ID: ZNFG900VM	 PCTEST Proud to be part of 	SAR EVALUATION REPORT		Approved by: Quality Manager
Document S/N: 1M2006040088-01-R1.ZNF	Test Dates: 06/25/20 – 08/05/20	DUT Type: Portable Handset	Page 61 of 159	

9.4.1

LTE Band 48

Table 9-54
LTE Band 48 Measured P_{Max} - 20 MHz Bandwidth

LTE Band 48 20 MHz Bandwidth								
Modulation	RB Size	RB Offset	Low Channel	Low-Mid Channel	Mid-High Channel	High Channel	MPR Allowed per 3GPP [dB]	MPR [dB]
			55340 (3560.0 MHz)	55773 (3603.3 MHz)	56207 (3646.7 MHz)	56640 (3690.0 MHz)		
Conducted Power [dBm]								
QPSK	1	0	24.00	23.84	23.97	23.89	0	0
	1	50	23.98	23.91	23.98	23.94		0
	1	99	23.99	23.90	23.96	23.97		0
	50	0	23.12	23.08	23.09	22.99	0-1	1
	50	25	23.25	23.09	23.18	23.12		1
	50	50	23.24	23.03	23.20	22.98		1
16QAM	100	0	23.10	23.03	23.09	23.04	0-1	1
	1	0	23.08	23.06	23.17	23.07		1
	1	50	23.21	23.08	23.23	23.10		1
	1	99	23.21	23.09	23.29	23.08	0-2	1
	50	0	22.08	22.02	22.11	22.09		2
	50	25	22.26	22.18	22.26	22.10		2
64QAM	50	50	22.15	22.02	22.23	22.01	0-2	2
	100	0	22.14	22.04	22.13	22.08		2
	1	0	21.83	21.76	21.89	21.63		0-3
	1	50	21.80	21.82	21.93	21.69	2	
	1	99	21.85	21.66	21.85	21.65	2	
	50	0	21.15	21.08	21.09	21.15	0-3	3
50	25	21.25	21.18	21.22	21.15	3		
50	50	21.14	21.12	21.25	21.02	3		
100	0	21.21	21.08	21.12	21.10		3	

Table 9-55
LTE Band 48 Measured P_{Max} - 15 MHz Bandwidth

LTE Band 48 15 MHz Bandwidth								
Modulation	RB Size	RB Offset	Low Channel	Low-Mid Channel	Mid-High Channel	High Channel	MPR Allowed per 3GPP [dB]	MPR [dB]
			55315 (3557.5 MHz)	55765 (3602.5 MHz)	56215 (3647.5 MHz)	56665 (3692.5 MHz)		
Conducted Power [dBm]								
QPSK	1	0	24.26	24.20	24.17	24.26	0	0
	1	36	24.28	24.29	24.11	24.20		0
	1	74	24.30	24.25	24.13	24.19		0
	36	0	23.37	23.35	23.37	23.34	0-1	1
	36	18	23.40	23.38	23.38	23.35		1
	36	37	23.38	23.37	23.37	23.30		1
16QAM	75	0	23.39	23.33	23.36	23.29	0-1	1
	1	0	23.40	23.38	23.38	23.40		1
	1	36	23.38	23.34	23.34	23.39		1
	1	74	23.39	23.32	23.39	23.40	0-2	1
	36	0	22.28	22.38	22.38	22.35		2
	36	18	22.35	22.39	22.30	22.37		2
64QAM	36	37	22.37	22.32	22.22	22.30	0-2	2
	75	0	22.38	22.37	22.28	22.31		2
	1	0	22.21	22.15	22.20	22.01		0-3
	1	36	22.18	22.40	22.30	22.22	2	
	1	74	22.20	21.99	22.35	22.19	2	
	36	0	21.38	21.40	21.34	21.35	0-3	3
36	18	21.39	21.40	21.40	21.38	3		
36	37	21.38	21.39	21.38	21.37	3		
75	0	21.34	21.35	21.34	21.36		3	



FCC ID: ZNFG900VM	 PCTEST Proud to be part of 	SAR EVALUATION REPORT		Approved by: Quality Manager
Document S/N: 1M2006040088-01-R1.ZNF	Test Dates: 06/25/20 – 08/05/20	DUT Type: Portable Handset		Page 62 of 159

Table 9-56
LTE Band 48 Measured P_{Max} - 10 MHz Bandwidth

LTE Band 48 10 MHz Bandwidth								
Modulation	RB Size	RB Offset	Low Channel	Low-Mid Channel	Mid-High Channel	High Channel	MPR Allowed per 3GPP [dB]	MPR [dB]
			55290 (3555.0 MHz)	55757 (3601.7 MHz)	56223 (3648.3 MHz)	56690 (3695.0 MHz)		
			Conducted Power [dBm]					
QPSK	1	0	24.16	24.01	24.17	24.21	0	0
	1	25	24.18	24.03	24.10	24.13		0
	1	49	24.20	24.00	24.04	24.11		0
	25	0	23.06	23.05	22.99	23.10	0-1	1
	25	12	23.20	23.12	23.20	23.14		1
	25	25	23.18	23.13	23.15	23.09		1
16QAM	1	0	23.09	23.12	23.08	23.10	0-1	1
	1	25	23.29	23.06	23.30	23.28		1
	1	49	23.29	23.09	23.30	23.18		1
	25	0	22.23	22.04	22.11	22.07	0-2	2
	25	12	22.30	22.20	22.20	22.10		2
	25	25	22.28	22.13	22.12	22.09		2
64QAM	50	0	22.29	22.05	22.10	22.16	0-2	2
	1	0	22.29	21.97	22.26	22.23		2
	1	25	22.27	21.92	22.22	22.22		2
	1	49	22.26	22.00	22.26	22.19	0-3	2
	25	0	21.26	21.02	21.25	21.01		3
	25	12	21.30	21.13	21.29	21.17		3
	25	25	21.27	21.12	21.28	21.10	3	
	50	0	21.23	21.00	21.24	21.08	3	

Table 9-57
LTE Band 48 Measured P_{Max} - 5 MHz Bandwidth

LTE Band 48 5 MHz Bandwidth								
Modulation	RB Size	RB Offset	Low Channel	Low-Mid Channel	Mid-High Channel	High Channel	MPR Allowed per 3GPP [dB]	MPR [dB]
			55265 (3552.5 MHz)	55748 (3600.8 MHz)	56232 (3649.2 MHz)	56715 (3697.5 MHz)		
			Conducted Power [dBm]					
QPSK	1	0	24.07	23.94	24.08	24.01	0	0
	1	12	24.19	24.05	24.15	24.15		0
	1	24	24.16	24.00	24.16	24.08		0
	12	0	23.20	23.08	23.16	23.12	0-1	1
	12	6	23.27	23.15	23.22	23.22		1
	12	13	23.26	23.17	23.21	23.18		1
16QAM	25	0	23.23	23.14	23.15	23.17	0-1	1
	1	0	23.30	23.29	23.29	23.27		1
	1	12	23.29	23.30	23.30	23.30		1
	1	24	23.29	23.28	23.28	23.28	0-2	1
	12	0	22.20	22.17	22.12	22.16		2
	12	6	22.25	22.24	22.16	22.21		2
64QAM	12	13	22.24	22.23	22.18	22.18	0-2	2
	25	0	22.23	22.17	22.20	22.19		2
	1	0	22.20	22.30	22.30	22.16		0-2
	1	12	22.29	22.30	22.30	22.28	2	
	1	24	22.26	22.29	22.29	22.21	2	
	64QAM	12	0	21.18	21.10	21.15	21.20	0-3
12		6	21.27	21.16	21.21	21.24	3	
12		13	21.23	21.15	21.22	21.20	3	
25		0	21.24	21.22	21.17	21.19	3	



FCC ID: ZNFG900VM	 PCTEST <small>Proud to be part of element</small>	SAR EVALUATION REPORT	 LG	Approved by: Quality Manager
Document S/N: 1M2006040088-01-R1.ZNF	Test Dates: 06/25/20 – 08/05/20	DUT Type: Portable Handset	Page 63 of 159	

Table 9-58
LTE Band 48 Measured P_{Limit} for DSI = 1 (Head, Body worn, and Phablet Max), DSI = 5 (Hotspot mode) and/or DSI = 8 (Phablet with grip sensor active) - 20 MHz Bandwidth

LTE Band 48 20 MHz Bandwidth								
Modulation	RB Size	RB Offset	Low Channel	Low-Mid Channel	Mid-High Channel	High Channel	MPR Allowed per 3GPP [dB]	MPR [dB]
			55340 (3560.0 MHz)	55773 (3603.3 MHz)	56207 (3646.7 MHz)	56640 (3690.0 MHz)		
			Conducted Power [dBm]					
QPSK	1	0	22.93	22.74	22.94	22.80	0	0
	1	50	23.01	22.85	22.98	22.70		0
	1	99	22.91	22.90	22.88	22.77		0
	50	0	22.97	22.96	23.03	22.94	0-1	0
	50	25	23.10	23.01	23.07	23.01		0
	50	50	22.95	22.91	23.01	22.82		0
	100	0	23.00	22.92	22.93	22.74		0
16QAM	1	0	23.33	23.30	23.02	23.14	0-1	0
	1	50	23.30	23.31	23.03	23.15		0
	1	99	23.26	23.30	22.99	23.15		0
	50	0	22.43	22.43	22.46	22.34	0-2	1
	50	25	22.44	22.50	22.46	22.43		1
	50	50	22.50	22.38	22.47	22.29		1
	100	0	22.48	22.42	22.44	22.36		1
64QAM	1	0	22.43	22.05	22.40	22.45	0-2	1
	1	50	22.48	22.06	22.48	22.33		1
	1	99	22.43	22.09	22.38	22.31		1
	50	0	21.49	21.47	21.45	21.39	0-3	2
	50	25	21.46	21.44	21.49	21.45		2
	50	50	21.48	21.42	21.47	21.27		2
	100	0	21.46	21.45	21.41	21.32		2

Table 9-59
LTE Band 48 Measured P_{Limit} for DSI = 1 (Head, Body worn, and Phablet Max), DSI = 5 (Hotspot mode) and/or DSI = 8 (Phablet with grip sensor active) - 15 MHz Bandwidth

LTE Band 48 15 MHz Bandwidth								
Modulation	RB Size	RB Offset	Low Channel	Low-Mid Channel	Mid-High Channel	High Channel	MPR Allowed per 3GPP [dB]	MPR [dB]
			55315 (3557.5 MHz)	55765 (3602.5 MHz)	56215 (3647.5 MHz)	56665 (3692.5 MHz)		
			Conducted Power [dBm]					
QPSK	1	0	22.96	22.82	22.97	22.85	0	0
	1	36	23.10	22.99	22.89	22.76		0
	1	74	22.82	22.82	22.90	22.89		0
	36	0	23.03	23.04	23.04	22.95	0-1	0
	36	18	23.04	22.97	23.03	22.93		0
	36	37	22.76	22.90	22.95	22.82		0
	75	0	23.03	22.90	22.91	22.68		0
16QAM	1	0	23.28	23.17	22.90	23.28	0-1	0
	1	36	23.37	23.38	22.99	23.07		0
	1	74	23.31	23.45	22.94	23.29		0
	36	0	22.38	22.50	22.36	22.42	0-2	1
	36	18	22.48	22.34	22.43	22.42		1
	36	37	22.45	22.30	22.46	22.31		1
	75	0	22.37	22.45	22.35	22.28		1
64QAM	1	0	22.42	22.18	22.47	22.45	0-2	1
	1	36	22.35	22.00	22.36	22.23		1
	1	74	22.43	22.19	22.41	22.29		1
	36	0	21.45	21.46	21.26	21.39	0-3	2
	36	18	21.48	21.35	21.49	21.33		2
	36	37	21.46	21.43	21.02	21.24		2
	75	0	21.30	21.42	21.06	21.33		2



FCC ID: ZNFG900VM	 PCTEST Proud to be part of element	SAR EVALUATION REPORT		Approved by: Quality Manager
Document S/N: 1M2006040088-01-R1.ZNF	Test Dates: 06/25/20 – 08/05/20	DUT Type: Portable Handset	Page 64 of 159	

Table 9-60



LTE Band 48 Measured P_{Limit} - for DSI = 1 (Head, Body worn, and Phablet Max), DSI = 5 (Hotspot mode) and/or DSI = 8 (Phablet with grip sensor active) - 10 MHz Bandwidth

LTE Band 48 10 MHz Bandwidth								
Modulation	RB Size	RB Offset	Low Channel	Low-Mid Channel	Mid-High Channel	High Channel	MPR Allowed per 3GPP [dB]	MPR [dB]
			55290 (3555.0 MHz)	55757 (3601.7 MHz)	56223 (3648.3 MHz)	56690 (3695.0 MHz)		
Conducted Power [dBm]								
QPSK	1	0	23.00	22.66	23.02	22.94	0	0
	1	25	22.96	22.85	22.88	22.77		0
	1	49	22.75	22.86	22.84	22.91		0
	25	0	23.03	23.01	23.04	23.01	0-1	0
	25	12	23.08	22.84	23.12	22.93		0
	25	25	22.72	22.93	22.98	22.86		0
16QAM	50	0	23.20	22.90	22.84	22.80	0-1	0
	1	0	23.24	23.16	22.92	23.34		0
	1	25	23.30	23.28	22.95	23.11		0
	1	49	23.31	23.37	22.90	23.40	0-2	1
	25	0	22.35	22.30	22.35	22.44		1
	25	12	22.15	22.38	22.35	22.34		1
64QAM	25	25	22.33	22.29	22.42	22.24	0-2	1
	50	0	22.50	22.40	22.24	22.23		1
	1	0	22.30	22.04	22.44	22.30		0-3
	1	25	22.45	21.96	22.23	22.22	1	
	1	49	22.41	22.10	22.27	22.25	1	
	25	0	21.41	21.42	21.23	21.37	2	
25	12	21.45	21.41	21.44	21.19	2		
25	25	21.38	21.40	20.85	21.31	2		
50	0	21.25	21.30	21.10	21.38	2		

Table 9-61

LTE Band 48 Measured P_{Limit} - for DSI = 1 (Head, Body worn, and Phablet Max), DSI = 5 (Hotspot mode) and/or DSI = 8 (Phablet with grip sensor active) - 5 MHz Bandwidth

LTE Band 48 5 MHz Bandwidth								
Modulation	RB Size	RB Offset	Low Channel	Low-Mid Channel	Mid-High Channel	High Channel	MPR Allowed per 3GPP [dB]	MPR [dB]
			55265 (3552.5 MHz)	55748 (3600.8 MHz)	56232 (3649.2 MHz)	56715 (3697.5 MHz)		
Conducted Power [dBm]								
QPSK	1	0	23.01	22.62	23.10	22.98	0	0
	1	12	22.85	22.82	22.98	22.63		0
	1	24	22.56	22.95	22.79	22.81		0
	12	0	23.04	22.93	23.04	23.02	0-1	0
	12	6	23.13	22.73	23.10	23.07		0
	12	13	22.64	22.92	23.12	22.72		0
16QAM	25	0	23.16	23.02	22.88	22.78	0-1	0
	1	0	23.30	23.02	23.02	23.26		0
	1	12	23.32	23.24	22.92	23.13		0
	1	24	23.36	23.38	22.83	23.38	0-2	1
	12	0	22.19	22.28	22.31	22.40		1
	12	6	22.17	22.26	22.32	22.34		1
64QAM	12	13	22.25	22.19	22.40	22.35	0-2	1
	25	0	22.30	22.40	22.33	22.33		1
	1	0	22.36	22.04	22.38	22.29		0-3
	1	12	22.16	22.04	22.29	22.18	1	
	1	24	22.42	22.09	22.33	22.34	1	
	12	0	21.46	21.37	21.23	21.35	2	
12	6	21.50	21.36	21.35	21.27	2		
12	13	21.42	21.39	20.76	21.29	2		
25	0	21.13	21.32	21.07	21.33	2		

FCC ID: ZNFG900VM	 PCTEST Proud to be part of 	SAR EVALUATION REPORT		Approved by: Quality Manager
Document S/N: 1M2006040088-01-R1.ZNF	Test Dates: 06/25/20 – 08/05/20	DUT Type: Portable Handset		Page 65 of 159

9.4.2 LTE Uplink Carrier Aggregation Conducted Powers

Table 9-62
LTE Band 5 Uplink Carrier Aggregation Measured P_{max}

Combination	PCC									SCC							Power			
	PCC Band	PCC Bandwidth [MHz]	PCC UL Channel	PCC UL Frequency [MHz]	PCC DL Channel	PCC DL Frequency [MHz]	Modulation	PCC UL# RB	PCC UL RB Offset	SCC Band	SCC Bandwidth [MHz]	SCC UL Channel	SCC UL Frequency [MHz]	SCC DL Channel	SCC DL Frequency [MHz]	Modulation	SCC UL# RB	SCC UL RB Offset	LTE Tx Power with UL CA Enabled (dBm)	LTE Single Carrier Tx Power (dBm)
CA_5B	LTE B5	10	20525	836.5	2525	881.5	QPSK	1	0	LTE B5	5	20453	829.3	2453	874.3	QPSK	1	24	25.50	25.30

Notes:

1. This device supports uplink carrier aggregation for LTE CA_5B with a maximum of two component carriers. For intraband contiguous carrier aggregation scenarios, 3GPP 36.101 Table 6.2.2A-1 specifies that the aggregate maximum allowed output power is equivalent to the single carrier scenario. 3GPP 36.101 6.2.3A allows for several dB of MPR to be applied when non-contiguous RB allocation is implemented. The conducted powers and MPR settings in this device are permanently implemented per the above 3GPP requirements.
2. Per FCC Guidance, the output power with uplink CA active was measured for the configuration with the highest reported SAR with single carrier for each exposure condition. The power was measured with wideband signal integration over both component carriers.



Figure 9-4
Power Measurement Setup

FCC ID: ZNFG900VM	PCTEST Proud to be part of element	SAR EVALUATION REPORT	LG	Approved by: Quality Manager
Document S/N: 1M2006040088-01-R1.ZNF	Test Dates: 06/25/20 – 08/05/20	DUT Type: Portable Handset	Page 66 of 159	

9.5 NR Conducted Powers

9.5.1 NR Band n5

Table 9-63
NR Band n5 Measured P_{max} for all DSI - 20 MHz Bandwidth

NR Band n5 20 MHz Bandwidth					
Modulation	RB Size	RB Offset	Channel	MPR Allowed per 3GPP [dB]	MPR [dB]
			167300 (836.5 MHz) Conducted Power [dBm]		
DFT-s-OFDM $\pi/2$ BPSK	1	1	24.21	0	0.0
	1	53	24.66		0.0
	1	104	24.08		0.0
	50	0	23.87	0-0.5	0.0
	50	28	24.54	0	0.0
	50	56	24.12	0-0.5	0.0
	100	0	23.85		0.0
DFT-s-OFDM QPSK	1	1	24.20	0	0.0
	1	53	24.60		0.0
	1	104	24.01		0.0
	50	0	23.31	0-1	1.0
	50	28	24.43	0	0.0
	50	56	23.59	0-1	1.0
	100	0	23.31		1.0
DFT-s-OFDM 16QAM	1	1	23.56	0-1	1.0
CP-OFDM QPSK	1	1	22.59	0-1.5	1.5

Note: NR Band n5 (Cell) at 20 MHz bandwidth does not support non-overlapping channels. Per FCC Guidance, when a device supports overlapping channel assignment in a channel bandwidth configuration, the middle channel of the group of overlapping channels should be selected for testing.



FCC ID: ZNFG900VM	 PCTEST Proud to be part of 	SAR EVALUATION REPORT		Approved by: Quality Manager
Document S/N: 1M2006040088-01-R1.ZNF	Test Dates: 06/25/20 – 08/05/20	DUT Type: Portable Handset		Page 67 of 159

Table 9-64
NR Band n5 Measured P_{max} for all DSI - 15 MHz Bandwidth

NR Band n5 15 MHz Bandwidth					
Modulation	RB Size	RB Offset	Channel		
			167300 (836.5 MHz)	MPR Allowed per 3GPP [dB]	MPR [dB]
			Conducted Power [dBm]		
DFT-s-OFDM $\pi/2$ BPSK	1	1	23.91	0	0.0
	1	40	24.21		0.0
	1	77	24.17		0.0
	36	0	23.53	0-0.5	0.0
	36	22	24.14	0	0.0
	36	43	23.69	0-0.5	0.0
	75	0	23.48		0.0
DFT-s-OFDM QPSK	1	1	23.90	0	0.0
	1	40	24.26		0.0
	1	77	24.14		0.0
	36	0	22.97	0-1	1.0
	36	22	24.04	0	0.0
	36	43	23.13	0-1	1.0
	75	0	22.97		1.0
DFT-s-OFDM 16QAM	1	1	22.85	0-1	1.0
CP-OFDM QPSK	1	1	21.90	0-1.5	1.5

Note: NR Band n5 (Cell) at 15 MHz bandwidth does not support non-overlapping channels. Per FCC Guidance, when a device supports overlapping channel assignment in a channel bandwidth configuration, the middle channel of the group of overlapping channels should be selected for testing.



FCC ID: ZNFG900VM	 PCTEST Proud to be part of 	SAR EVALUATION REPORT	 LG	Approved by: Quality Manager
Document S/N: 1M2006040088-01-R1.ZNF	Test Dates: 06/25/20 – 08/05/20	DUT Type: Portable Handset	Page 68 of 159	

Table 9-65
NR Band n5 Measured P_{max} for all DSI - 10 MHz Bandwidth

NR Band n5 10 MHz Bandwidth					
Modulation	RB Size	RB Offset	Channel		
			167300 (836.5 MHz)	MPR Allowed per 3GPP [dB]	MPR [dB]
			Conducted Power [dBm]		
DFT-s-OFDM $\pi/2$ BPSK	1	1	24.66	0	0.0
	1	26	24.58		0.0
	1	50	24.59		0.0
	25	0	24.10	0-0.5	0.0
	25	14	24.74	0	0.0
	25	27	24.03	0-0.5	0.0
	50	0	24.10		0.0
DFT-s-OFDM QPSK	1	1	24.59	0	0.0
	1	26	24.71		0.0
	1	50	24.58		0.0
	25	0	23.50	0-1	1.0
	25	14	24.65	0	0.0
	25	27	23.48	0-1	1.0
	50	0	23.52		1.0
DFT-s-OFDM 16QAM	1	1	23.40	0-1	1.0
CP-OFDM QPSK	1	1	22.79	0-1.5	1.5

Note: NR Band n5 (Cell) at 10 MHz bandwidth does not support non-overlapping channels. Per FCC Guidance, when a device supports overlapping channel assignment in a channel bandwidth configuration, the middle channel of the group of overlapping channels should be selected for testing.





FCC ID: ZNFG900VM	 PCTEST Proud to be part of element	SAR EVALUATION REPORT	 LG	Approved by: Quality Manager
Document S/N: 1M2006040088-01-R1.ZNF	Test Dates: 06/25/20 – 08/05/20	DUT Type: Portable Handset	Page 69 of 159	

Table 9-66
NR Band n5 Measured P_{max} for all DSI - 5 MHz Bandwidth

NR Band n5 5 MHz Bandwidth							
			Channel			MPR Allowed per 3GPP [dB]	MPR [dB]
Modulation	RB Size	RB Offset	165300 (826.5 MHz)	167300 (836.5 MHz)	169300 (846.5 MHz)		
			Conducted Power [dBm]				
DFT-s-OFDM $\pi/2$ BPSK	1	1	24.80	24.73	24.59	0	0.0
	1	13	24.70	24.74	24.56		0.0
	1	23	24.61	24.66	24.47		0.0
	12	0	24.19	24.11	23.98	0-0.5	0.0
	12	7	24.77	24.71	24.54	0	0.0
	12	13	24.07	24.03	23.84	0-0.5	0.0
	25	0	24.09	24.05	23.86		0.0
DFT-s-OFDM QPSK	1	1	24.78	24.69	24.57	0	0.0
	1	13	24.75	24.68	24.52		0.0
	1	23	24.63	24.55	24.41		0.0
	12	0	23.66	23.62	23.44	0-1	1.0
	12	7	24.64	24.62	24.44	0	0.0
	12	13	23.55	23.50	23.27	0-1	1.0
	25	0	23.53	23.52	23.34		1.0
DFT-s-OFDM 16QAM	1	1	23.62	23.49	23.42	0-1	1.0
CP-OFDM QPSK	1	1	23.00	22.86	22.81	0-1.5	1.5

FCC ID: ZNFG900VM	 PCTEST Proud to be part of 	SAR EVALUATION REPORT		Approved by: Quality Manager
Document S/N: 1M2006040088-01-R1.ZNF	Test Dates: 06/25/20 – 08/05/20	DUT Type: Portable Handset	Page 70 of 159	

9.5.2

NR Band n66 (AWS)

Table 9-67
NR Band n66 (AWS) Measured P_{Max} - 20 MHz Bandwidth

NR Band n66 20 MHz Bandwidth							
Modulation	RB Size	RB Offset	Channel			MPR Allowed per 3GPP [dB]	MPR [dB]
			344000 (1720 MHz)	349000 (1745 MHz)	354000 (1770 MHz)		
			Conducted Power [dBm]				
DFT-s-OFDM $\pi/2$ BPSK	1	1	24.72	24.73	24.71	0	0.0
	1	53	24.69	24.60	24.64		0.0
	1	104	24.75	24.71	24.80		0.0
	50	0	24.10	24.08	24.11	0-0.5	0.0
	50	28	24.77	24.72	24.76	0	0.0
	50	56	24.16	24.05	24.16	0-0.5	0.0
	100	0	24.20	24.11	24.10		0.0
DFT-s-OFDM QPSK	1	1	24.71	24.67	24.72	0	0.0
	1	53	24.62	24.55	24.66		0.0
	1	104	25.01	25.01	25.02		0.0
	50	0	23.59	23.52	23.58	0-1	1.0
	50	28	24.76	24.60	24.69	0	0.0
	50	56	23.62	23.52	23.57	0-1	1.0
	100	0	23.61	23.56	23.58		1.0
DFT-s-OFDM 16QAM	1	1	23.96	24.05	23.96	0-1	1.0
CP-OFDM QPSK	1	1	23.21	23.22	23.30	0-1.5	1.5

Table 9-68
NR Band n66 (AWS) Measured P_{Max} - 15 MHz Bandwidth

NR Band n66 15 MHz Bandwidth							
Modulation	RB Size	RB Offset	Channel			MPR Allowed per 3GPP [dB]	MPR [dB]
			343500 (1717.5 MHz)	349000 (1745 MHz)	354500 (1772.5 MHz)		
			Conducted Power [dBm]				
DFT-s-OFDM $\pi/2$ BPSK	1	1	24.82	24.71	24.71	0	0.0
	1	40	24.71	24.70	24.63		0.0
	1	77	24.84	24.71	24.79		0.0
	36	0	24.13	24.05	24.01	0-0.5	0.0
	36	22	24.64	24.59	24.53	0	0.0
	36	43	24.12	24.05	24.02	0-0.5	0.0
	75	0	24.11	24.06	24.03		0.0
DFT-s-OFDM QPSK	1	1	24.75	24.78	24.84	0	0.0
	1	40	24.70	24.65	24.73		0.0
	1	77	24.88	24.86	24.85		0.0
	36	0	23.46	23.46	23.48	0-1	1.0
	36	22	24.54	24.52	24.47	0	0.0
	36	43	23.55	23.49	23.48	0-1	1.0
	75	0	23.57	23.54	23.54		1.0
DFT-s-OFDM 16QAM	1	1	23.50	23.52	23.55	0-1	1.0
CP-OFDM QPSK	1	1	22.70	22.74	22.76	0-1.5	1.5



FCC ID: ZNFG900VM	 PCTEST Proud to be part of 	SAR EVALUATION REPORT		Approved by: Quality Manager
Document S/N: 1M2006040088-01-R1.ZNF	Test Dates: 06/25/20 – 08/05/20	DUT Type: Portable Handset		Page 71 of 159

Table 9-69
NR Band n66 (AWS) Measured P_{Max} - 10 MHz Bandwidth

NR Band n66 10 MHz Bandwidth							
Modulation	RB Size	RB Offset	Channel			MPR Allowed per 3GPP [dB]	MPR [dB]
			343000 (1715 MHz)	349000 (1745 MHz)	355000 (1775 MHz)		
			Conducted Power [dBm]				
DFT-s-OFDM $\pi/2$ BPSK	1	1	24.57	24.54	24.63	0	0.0
	1	26	24.65	24.58	24.70		0.0
	1	50	24.65	24.61	24.72		0.0
	25	0	23.92	24.03	24.08	0-0.5	0.0
	25	14	24.71	24.73	24.75	0	0.0
	25	27	24.03	24.02	24.07	0-0.5	0.0
	50	0	24.02	24.07	24.05		0.0
DFT-s-OFDM QPSK	1	1	24.56	24.71	24.77	0	0.0
	1	26	24.67	24.64	24.65		0.0
	1	50	24.70	24.78	24.73		0.0
	25	0	23.38	23.55	23.56	0-1	1.0
	25	14	24.63	24.62	24.66	0	0.0
	25	27	23.49	23.52	23.49	0-1	1.0
	50	0	23.50	23.52	23.46		1.0
DFT-s-OFDM 16QAM	1	1	23.22	23.45	23.31	0-1	1.0
CP-OFDM QPSK	1	1	22.56	22.57	22.63	0-1.5	1.5

Table 9-70
NR Band n66 (AWS) Measured P_{Max} - 5 MHz Bandwidth

NR Band n66 5 MHz Bandwidth							
Modulation	RB Size	RB Offset	Channel			MPR Allowed per 3GPP [dB]	MPR [dB]
			342500 (1712.5 MHz)	349000 (1745 MHz)	355500 (1777.5 MHz)		
			Conducted Power [dBm]				
DFT-s-OFDM $\pi/2$ BPSK	1	1	24.58	24.67	24.57	0	0.0
	1	13	24.71	24.72	24.74		0.0
	1	23	24.59	24.69	24.63		0.0
	12	0	24.01	24.03	24.00	0-0.5	0.0
	12	7	24.67	24.76	24.71	0	0.0
	12	13	23.97	24.04	24.01	0-0.5	0.0
	25	0	23.99	24.05	24.02		0.0
DFT-s-OFDM QPSK	1	1	24.58	24.69	24.60	0	0.0
	1	13	24.67	24.80	24.77		0.0
	1	23	24.61	24.66	24.62		0.0
	12	0	23.48	23.53	23.51	0-1	1.0
	12	7	24.50	24.64	24.57	0	0.0
	12	13	23.42	23.53	23.53	0-1	1.0
	25	0	23.41	23.52	23.51		1.0
DFT-s-OFDM 16QAM	1	1	23.30	23.40	23.44	0-1	1.0
CP-OFDM QPSK	1	1	22.48	22.49	22.65	0-1.5	1.5



FCC ID: ZNFG900VM	 PCTEST Proud to be part of 	SAR EVALUATION REPORT		Approved by: Quality Manager
Document S/N: 1M2006040088-01-R1.ZNF	Test Dates: 06/25/20 – 08/05/20	DUT Type: Portable Handset	Page 72 of 159	

Table 9-71
NR Band n66 (AWS) Measured P_{Limit} for DSI = 1 (Head, Body worn, and Phablet Max), DSI = 5 (Hotspot mode) and/or DSI = 8 (Phablet with grip sensor active) - 20 MHz Bandwidth

NR Band n66 20 MHz Bandwidth							
Modulation	RB Size	RB Offset	Channel			MPR Allowed per 3GPP [dB]	MPR [dB]
			344000 (1720 MHz)	349000 (1745 MHz)	354000 (1770 MHz)		
			Conducted Power [dBm]				
DFT-s-OFDM $\pi/2$ BPSK	1	1	23.77	23.68	23.68	0	0.0
	1	53	23.61	23.55	23.58		0.0
	1	104	23.74	23.63	23.70		0.0
	50	0	23.67	23.55	23.55	0-0.5	0.0
	50	28	23.80	23.67	23.73	0	0.0
	50	56	23.63	23.56	23.56	0-0.5	0.0
	100	0	23.62	23.57	23.57		0.0
DFT-s-OFDM QPSK	1	1	23.74	23.66	23.66	0	0.0
	1	53	23.58	23.55	23.62		0.0
	1	104	23.76	23.62	23.71		0.0
	50	0	23.58	23.49	23.54	0-1	0.0
	50	28	23.75	23.70	23.62	0	0.0
	50	56	23.57	23.49	23.53	0-1	0.0
	100	0	23.52	23.60	23.49		0.0
DFT-s-OFDM 16QAM	1	1	24.03	23.93	23.86	0-1	0.0
CP-OFDM QPSK	1	1	23.13	23.15	23.14	0-1.5	0.5



FCC ID: ZNFG900VM	 PCTEST Proud to be part of 	SAR EVALUATION REPORT		Approved by: Quality Manager
Document S/N: 1M2006040088-01-R1.ZNF	Test Dates: 06/25/20 – 08/05/20	DUT Type: Portable Handset		Page 73 of 159

Table 9-72

NR Band n66 (AWS) Measured P_{Limit} for DSI = 1 (Head, Body worn, and Phablet Max), DSI = 5 (Hotspot mode) and/or DSI = 8 (Phablet with grip sensor active) - 15 MHz Bandwidth

NR Band n66 15 MHz Bandwidth							
Modulation	RB Size	RB Offset	Channel			MPR Allowed per 3GPP [dB]	MPR [dB]
			343500 (1717.5 MHz)	349000 (1745 MHz)	354500 (1772.5 MHz)		
			Conducted Power [dBm]				
DFT-s-OFDM $\pi/2$ BPSK	1	1	23.80	23.79	23.68	0	0.0
	1	40	23.70	23.65	23.64		0.0
	1	77	23.89	23.81	23.79		0.0
	36	0	23.55	23.60	23.50	0-0.5	0.0
	36	22	23.62	23.62	23.54	0	0.0
	36	43	23.65	23.60	23.57	0-0.5	0.0
	75	0	23.55	23.62	23.58		0.0
DFT-s-OFDM QPSK	1	1	23.75	23.78	23.82	0	0.0
	1	40	23.66	23.66	23.66		0.0
	1	77	23.88	23.68	23.83		0.0
	36	0	23.54	23.53	23.51	0-1	0.0
	36	22	23.50	23.54	23.49	0	0.0
	36	43	23.59	23.53	23.50	0-1	0.0
	75	0	23.50	23.58	23.55		0.0
DFT-s-OFDM 16QAM	1	1	23.55	23.60	23.55	0-1	0.0
CP-OFDM QPSK	1	1	22.74	22.73	22.70	0-1.5	0.5



FCC ID: ZNFG900VM	 PCTEST Proud to be part of element	SAR EVALUATION REPORT	 LG	Approved by: Quality Manager
Document S/N: 1M2006040088-01-R1.ZNF	Test Dates: 06/25/20 – 08/05/20	DUT Type: Portable Handset	Page 74 of 159	

Table 9-73

NR Band n66 (AWS) Measured P_{Limit} for DSI = 1 (Head, Body worn, and Phablet Max), DSI = 5 (Hotspot mode) and/or DSI = 8 (Phablet with grip sensor active) - 10 MHz Bandwidth

NR Band n66 10 MHz Bandwidth							
Modulation	RB Size	RB Offset	Channel			MPR Allowed per 3GPP [dB]	MPR [dB]
			343000 (1715 MHz)	349000 (1745 MHz)	355000 (1775 MHz)		
			Conducted Power [dBm]				
DFT-s-OFDM $\pi/2$ BPSK	1	1	23.64	23.66	23.64	0	0.0
	1	26	23.63	23.67	23.62		0.0
	1	50	23.71	23.68	23.70		0.0
	25	0	23.50	23.57	23.56	0-0.5	0.0
	25	14	23.71	23.75	23.74	0	0.0
	25	27	23.53	23.55	23.53	0-0.5	0.0
	50	0	23.50	23.56	23.57		0.0
DFT-s-OFDM QPSK	1	1	23.64	23.73	23.64	0	0.0
	1	26	23.59	23.69	23.67		0.0
	1	50	23.70	23.65	23.73		0.0
	25	0	23.51	23.56	23.48	0-1	0.0
	25	14	23.66	23.64	23.62	0	0.0
	25	27	23.50	23.55	23.52	0-1	0.0
	50	0	23.54	23.49	23.50		0.0
DFT-s-OFDM 16QAM	1	1	23.23	23.46	23.38	0-1	0.0
CP-OFDM QPSK	1	1	22.57	22.58	22.63	0-1.5	0.5





FCC ID: ZNFG900VM	 PCTEST Proud to be part of 	SAR EVALUATION REPORT		Approved by: Quality Manager
Document S/N: 1M2006040088-01-R1.ZNF	Test Dates: 06/25/20 – 08/05/20	DUT Type: Portable Handset		Page 75 of 159

Table 9-74

NR Band n66 (AWS) Measured P_{Limit} for DSI = 1 (Head, Body worn, and Phablet Max), DSI = 5 (Hotspot mode) and/or DSI = 8 (Phablet with grip sensor active)- 5 MHz Bandwidth

NR Band n66 5 MHz Bandwidth							
Modulation	RB Size	RB Offset	Channel			MPR Allowed per 3GPP [dB]	MPR [dB]
			342500 (1712.5 MHz)	349000 (1745 MHz)	355500 (1777.5 MHz)		
			Conducted Power [dBm]				
DFT-s-OFDM $\pi/2$ BPSK	1	1	23.54	23.44	23.48	0	0.0
	1	13	23.60	23.56	23.55		0.0
	1	23	23.57	23.41	23.51		0.0
	12	0	23.39	23.38	23.45	0-0.5	0.0
	12	7	23.65	23.52	23.62	0	0.0
	12	13	23.46	23.35	23.39	0-0.5	0.0
	25	0	23.39	23.33	23.39		0.0
DFT-s-OFDM QPSK	1	1	23.55	23.44	23.50	0	0.0
	1	13	23.57	23.46	23.56		0.0
	1	23	23.56	23.45	23.52		0.0
	12	0	23.35	23.32	23.40	0-1	0.0
	12	7	23.50	23.43	23.53	0	0.0
	12	13	23.38	23.31	23.41	0-1	0.0
	25	0	23.40	23.32	23.39		0.0
DFT-s-OFDM 16QAM	1	1	23.36	23.27	23.42	0-1	0.0
CP-OFDM QPSK	1	1	22.67	22.53	22.56	0-1.5	0.5

FCC ID: ZNFG900VM	 PCTEST Proud to be part of element	SAR EVALUATION REPORT		Approved by: Quality Manager
Document S/N: 1M2006040088-01-R1.ZNF	Test Dates: 06/25/20 – 08/05/20	DUT Type: Portable Handset		Page 76 of 159

9.5.3

NR Band n2 (PCS)

Table 9-75
NR Band n2 (PCS) Measured P_{Max} - 20 MHz Bandwidth

NR Band n2 20 MHz Bandwidth							
Modulation	RB Size	RB Offset	Channel			MPR Allowed per 3GPP [dB]	MPR [dB]
			372000 (1860 MHz)	376000 (1880 MHz)	380000 (1900 MHz)		
			Conducted Power [dBm]				
DFT-s-OFDM $\pi/2$ BPSK	1	1	24.70	24.62	24.64	0	0.0
	1	53	24.63	24.61	24.68		0.0
	1	104	24.65	24.64	24.69		0.0
	50	0	24.03	23.99	23.94	0-0.5	0.0
	50	28	24.70	24.64	24.67	0	0.0
	50	56	24.01	23.96	24.09	0-0.5	0.0
	100	0	24.06	23.98	24.01		0.0
DFT-s-OFDM QPSK	1	1	24.64	24.56	24.57	0	0.0
	1	53	24.57	24.55	24.59		0.0
	1	104	24.63	24.57	24.61		0.0
	50	0	23.51	23.43	23.42	0-1	1.0
	50	28	24.65	24.54	24.56	0	0.0
	50	56	23.52	23.42	23.49	0-1	1.0
	100	0	23.55	23.43	23.46		1.0
DFT-s-OFDM 16QAM	1	1	23.60	23.62	23.53	0-1	1.0
CP-OFDM QPSK	1	1	22.79	22.63	22.61	0-1.5	1.5



FCC ID: ZNFG900VM	 PCTEST Proud to be part of 	SAR EVALUATION REPORT		Approved by: Quality Manager
Document S/N: 1M2006040088-01-R1.ZNF	Test Dates: 06/25/20 – 08/05/20	DUT Type: Portable Handset		Page 77 of 159

Table 9-76
NR Band n2 (PCS) Measured P_{Max} - 15 MHz Bandwidth

NR Band n2 15 MHz Bandwidth							
			Channel			MPR Allowed per 3GPP [dB]	MPR [dB]
Modulation	RB Size	RB Offset	371500 (1857.5 MHz)	376000 (1880 MHz)	380500 (1902.5 MHz)		
			Conducted Power [dBm]				
DFT-s-OFDM $\pi/2$ BPSK	1	1	24.59	24.55	24.59	0	0.0
	1	40	24.57	24.50	24.67		0.0
	1	77	24.56	24.56	24.68		0.0
	36	0	23.92	23.83	23.93	0-0.5	0.0
	36	22	24.49	24.39	24.51	0	0.0
	36	43	23.97	23.88	24.04	0-0.5	0.0
	75	0	23.91	23.87	23.95		0.0
DFT-s-OFDM QPSK	1	1	24.54	24.51	24.54	0	0.0
	1	40	24.55	24.46	24.59		0.0
	1	77	24.54	24.49	24.61		0.0
	36	0	23.33	23.25	23.39	0-1	1.0
	36	22	24.39	24.31	24.48	0	0.0
	36	43	23.52	23.34	23.47	0-1	1.0
	75	0	23.54	23.32	23.50		1.0
DFT-s-OFDM 16QAM	1	1	23.69	23.59	23.33	0-1	1.0
CP-OFDM QPSK	1	1	22.84	22.55	22.35	0-1.5	1.5



FCC ID: ZNFG900VM	 PCTEST Proud to be part of 	SAR EVALUATION REPORT		Approved by: Quality Manager
Document S/N: 1M2006040088-01-R1.ZNF	Test Dates: 06/25/20 – 08/05/20	DUT Type: Portable Handset		Page 78 of 159

Table 9-77
NR Band n2 (PCS) Measured P_{Max} - 10 MHz Bandwidth

NR Band n2 10 MHz Bandwidth							
			Channel			MPR Allowed per 3GPP [dB]	MPR [dB]
Modulation	RB Size	RB Offset	371000 (1855 MHz)	376000 (1880 MHz)	381000 (1905 MHz)		
			Conducted Power [dBm]				
DFT-s-OFDM $\pi/2$ BPSK	1	1	24.49	24.41	24.39	0	0.0
	1	26	24.57	24.48	24.50		0.0
	1	50	24.56	24.55	24.51		0.0
	25	0	23.88	23.87	23.83	0-0.5	0.0
	25	14	24.55	24.52	24.55	0	0.0
	25	27	23.95	23.94	23.88	0-0.5	0.0
	50	0	23.91	23.87	23.86		0.0
DFT-s-OFDM QPSK	1	1	24.53	24.44	24.46	0	0.0
	1	26	24.44	24.50	24.49		0.0
	1	50	24.50	24.51	24.51		0.0
	25	0	23.33	23.29	23.26	0-1	1.0
	25	14	24.43	24.45	24.45	0	0.0
	25	27	23.33	23.39	23.34	0-1	1.0
	50	0	23.34	23.37	23.34		1.0
DFT-s-OFDM 16QAM	1	1	23.51	23.18	23.47	0-1	1.0
CP-OFDM QPSK	1	1	22.62	22.54	22.43	0-1.5	1.5



FCC ID: ZNFG900VM	 PCTEST Proud to be part of element	SAR EVALUATION REPORT		Approved by: Quality Manager
Document S/N: 1M2006040088-01-R1.ZNF	Test Dates: 06/25/20 – 08/05/20	DUT Type: Portable Handset	Page 79 of 159	

Table 9-78
NR Band n2 (PCS) Measured P_{Max} - 5 MHz Bandwidth

NR Band n2 5 MHz Bandwidth							
Modulation	RB Size	RB Offset	Channel			MPR Allowed per 3GPP [dB]	MPR [dB]
			370500 (1852.5 MHz)	376000 (1880 MHz)	381500 (1907.5 MHz)		
			Conducted Power [dBm]				
DFT-s-OFDM $\pi/2$ BPSK	1	1	24.47	24.46	24.46	0	0.0
	1	13	24.62	24.63	24.55		0.0
	1	23	24.50	24.56	24.34		0.0
	12	0	23.86	23.86	23.84	0-0.5	0.0
	12	7	24.59	24.57	24.51	0	0.0
	12	13	23.97	23.96	23.89	0-0.5	0.0
	25	0	23.82	23.84	23.80		0.0
DFT-s-OFDM QPSK	1	1	24.42	24.49	24.42	0	0.0
	1	13	24.51	24.48	24.53		0.0
	1	23	24.46	24.53	24.43		0.0
	12	0	23.31	23.30	23.28	0-1	1.0
	12	7	24.46	24.39	24.40	0	0.0
	12	13	23.39	23.42	23.31	0-1	1.0
	25	0	23.26	23.33	23.28		1.0
DFT-s-OFDM 16QAM	1	1	23.53	23.55	23.55	0-1	1.0
CP-OFDM QPSK	1	1	22.49	22.52	22.54	0-1.5	1.5



FCC ID: ZNFG900VM	 PCTEST Proud to be part of 	SAR EVALUATION REPORT		Approved by: Quality Manager
Document S/N: 1M2006040088-01-R1.ZNF	Test Dates: 06/25/20 – 08/05/20	DUT Type: Portable Handset	Page 80 of 159	

Table 9-79

NR Band n2 (PCS) Measured P_{limit} for DSI = 1 (Head, Body worn, and Phablet Max), DSI = 5 (Hotspot mode) and/or DSI = 8 (Phablet with grip sensor active)- 20 MHz Bandwidth

NR Band n2 20 MHz Bandwidth							
Modulation	RB Size	RB Offset	Channel			MPR Allowed per 3GPP [dB]	MPR [dB]
			372000 (1860 MHz)	376000 (1880 MHz)	380000 (1900 MHz)		
			Conducted Power [dBm]				
DFT-s-OFDM $\pi/2$ BPSK	1	1	23.72	23.63	23.57	0	0.0
	1	53	23.75	23.66	23.64		0.0
	1	104	23.67	23.62	23.66		0.0
	50	0	23.54	23.47	23.47	0-0.5	0.0
	50	28	23.75	23.65	23.66	0	0.0
	50	56	23.56	23.51	23.54	0-0.5	0.0
	100	0	23.57	23.52	23.56		0.0
DFT-s-OFDM QPSK	1	1	23.72	23.55	23.51	0	0.0
	1	53	23.65	23.60	23.60		0.0
	1	104	23.54	23.61	23.62		0.0
	50	0	23.52	23.44	23.42	0-1	0.0
	50	28	23.62	23.58	23.59	0	0.0
	50	56	23.53	23.43	23.50	0-1	0.0
	100	0	23.49	23.45	23.49		0.0
DFT-s-OFDM 16QAM	1	1	23.66	23.67	23.59	0-1	0.0
CP-OFDM QPSK	1	1	22.84	22.71	22.81	0-1.5	0.5



FCC ID: ZNFG900VM	 PCTEST Proud to be part of 	SAR EVALUATION REPORT		Approved by: Quality Manager
Document S/N: 1M2006040088-01-R1.ZNF	Test Dates: 06/25/20 – 08/05/20	DUT Type: Portable Handset		Page 81 of 159

Table 9-80

NR Band n2 (PCS) Measured P_{limit} for DSI = 1 (Head, Body worn, and Phablet Max), DSI = 5 (Hotspot mode) and/or DSI = 8 (Phablet with grip sensor active)- 15 MHz Bandwidth

NR Band n2 15 MHz Bandwidth							
Modulation	RB Size	RB Offset	Channel			MPR Allowed per 3GPP [dB]	MPR [dB]
			371500 (1857.5 MHz)	376000 (1880 MHz)	380500 (1902.5 MHz)		
			Conducted Power [dBm]				
DFT-s-OFDM $\pi/2$ BPSK	1	1	23.72	23.65	23.60	0	0.0
	1	40	23.77	23.64	23.71		0.0
	1	77	23.70	23.65	23.73		0.0
	36	0	23.50	23.42	23.44	0-0.5	0.0
	36	22	23.57	23.46	23.54	0	0.0
	36	43	23.53	23.45	23.59	0-0.5	0.0
	75	0	23.53	23.46	23.53		0.0
DFT-s-OFDM QPSK	1	1	23.68	23.52	23.61	0	0.0
	1	40	23.70	23.58	23.63		0.0
	1	77	23.64	23.57	23.61		0.0
	36	0	23.49	23.38	23.40	0-1	0.0
	36	22	23.51	23.44	23.49	0	0.0
	36	43	23.51	23.45	23.52	0-1	0.0
	75	0	23.47	23.44	23.51		0.0
DFT-s-OFDM 16QAM	1	1	23.84	23.71	23.70	0-1	0.0
CP-OFDM QPSK	1	1	22.88	22.65	22.63	0-1.5	0.5



FCC ID: ZNFG900VM	 PCTEST Proud to be part of 	SAR EVALUATION REPORT		Approved by: Quality Manager
Document S/N: 1M2006040088-01-R1.ZNF	Test Dates: 06/25/20 – 08/05/20	DUT Type: Portable Handset		Page 82 of 159

Table 9-81

NR Band n2 (PCS) Measured P_{limit} for DSI = 1 (Head, Body worn, and Phablet Max), DSI = 5 (Hotspot mode) and/or DSI = 8 (Phablet with grip sensor active)- 10 MHz Bandwidth

NR Band n2 10 MHz Bandwidth							
Modulation	RB Size	RB Offset	Channel			MPR Allowed per 3GPP [dB]	MPR [dB]
			371000 (1855 MHz)	376000 (1880 MHz)	381000 (1905 MHz)		
			Conducted Power [dBm]				
DFT-s-OFDM $\pi/2$ BPSK	1	1	23.46	23.47	23.36	0	0.0
	1	26	23.51	23.49	23.43		0.0
	1	50	23.52	23.56	23.41		0.0
	25	0	23.41	23.35	23.32	0-0.5	0.0
	25	14	23.54	23.56	23.49	0	0.0
	25	27	23.40	23.45	23.39	0-0.5	0.0
	50	0	23.42	23.44	23.36		0.0
DFT-s-OFDM QPSK	1	1	23.44	23.53	23.50	0	0.0
	1	26	23.45	23.52	23.47		0.0
	1	50	23.52	23.53	23.45		0.0
	25	0	23.32	23.34	23.27	0-1	0.0
	25	14	23.45	23.47	23.39	0	0.0
	25	27	23.39	23.38	23.34	0-1	0.0
	50	0	23.37	23.35	23.32		0.0
DFT-s-OFDM 16QAM	1	1	23.56	23.46	23.46	0-1	0.0
CP-OFDM QPSK	1	1	22.66	22.61	22.35	0-1.5	0.5







FCC ID: ZNFG900VM	 PCTEST Proud to be part of 	SAR EVALUATION REPORT		Approved by: Quality Manager
Document S/N: 1M2006040088-01-R1.ZNF	Test Dates: 06/25/20 – 08/05/20	DUT Type: Portable Handset		Page 83 of 159

Table 9-82

NR Band n2 (PCS) Measured P_{limit} for DSI = 1 (Head, Body worn, and Phablet Max), DSI = 5 (Hotspot mode) and/or DSI = 8 (Phablet with grip sensor active)- 5 MHz Bandwidth

NR Band n2 5 MHz Bandwidth							
Modulation	RB Size	RB Offset	Channel			MPR Allowed per 3GPP [dB]	MPR [dB]
			370500 (1852.5 MHz)	376000 (1880 MHz)	381500 (1907.5 MHz)		
			Conducted Power [dBm]				
DFT-s-OFDM $\pi/2$ BPSK	1	1	23.44	23.41	23.40	0	0.0
	1	13	23.62	23.55	23.51		0.0
	1	23	23.51	23.47	23.48		0.0
	12	0	23.38	23.35	23.32	0-0.5	0.0
	12	7	23.51	23.54	23.49	0	0.0
	12	13	23.44	23.40	23.40	0-0.5	0.0
	25	0	23.31	23.34	23.31		0.0
DFT-s-OFDM QPSK	1	1	23.44	23.46	23.35	0	0.0
	1	13	23.55	23.57	23.45		0.0
	1	23	23.51	23.59	23.47		0.0
	12	0	23.26	23.34	23.29	0-1	0.0
	12	7	23.38	23.36	23.41	0	0.0
	12	13	23.34	23.37	23.28	0-1	0.0
	25	0	23.32	23.29	23.32		0.0
DFT-s-OFDM 16QAM	1	1	23.56	23.43	23.43	0-1	0.0
CP-OFDM QPSK	1	1	22.57	22.49	22.48	0-1.5	0.5

FCC ID: ZNFG900VM	 PCTEST Proud to be part of 	SAR EVALUATION REPORT		Approved by: Quality Manager
Document S/N: 1M2006040088-01-R1.ZNF	Test Dates: 06/25/20 – 08/05/20	DUT Type: Portable Handset	Page 84 of 159	

9.6 WLAN Conducted Powers

Table 9-83
2.4 GHz WLAN Maximum Average RF Power – Ant 1

2.4GHz Conducted Power [dBm]					
Freq [MHz]	Channel	IEEE Transmission Mode			
		802.11b	802.11g	802.11n	802.11ac
		Average	Average	Average	Average
2412	1	19.75	15.62	15.02	15.06
2422	3		18.87	17.55	17.63
2437	6	19.84	18.89	17.51	17.57
2452	9		18.88	17.63	17.64
2462	11	19.53	16.11	15.11	15.12

Table 9-84
2.4 GHz WLAN Maximum Average RF Power – Ant 2



2.4GHz Conducted Power [dBm]					
Freq [MHz]	Channel	IEEE Transmission Mode			
		802.11b	802.11g	802.11n	802.11ac
		Average	Average	Average	Average
2412	1	19.52	16.19	15.07	15.09
2422	3		19.17	18.11	18.18
2437	6	20.04	19.13	18.32	18.31
2452	9		19.05	18.21	18.14
2462	11	19.66	16.25	15.26	15.35

Table 9-85
2.4 GHz WLAN Reduced Average RF Power– Ant 1

2.4GHz Conducted Power [dBm]					
Freq [MHz]	Channel	IEEE Transmission Mode			
		802.11b	802.11g	802.11n	802.11ac
		Average	Average	Average	Average
2412	1	14.21	14.32	14.30	14.13
2437	6	14.51	14.45	14.18	14.27
2462	11	14.35	14.38	14.12	14.09

Table 9-86
2.4 GHz WLAN Reduced Average RF Power – Ant 2

2.4GHz Conducted Power [dBm]					
Freq [MHz]	Channel	IEEE Transmission Mode			
		802.11b	802.11g	802.11n	802.11ac
		Average	Average	Average	Average
2412	1	14.13	14.34	14.15	14.14
2437	6	14.66	14.93	14.83	14.75
2462	11	14.49	14.65	14.56	14.54

FCC ID: ZNFG900VM	 PCTEST Proud to be part of element	SAR EVALUATION REPORT	 LG	Approved by: Quality Manager
Document S/N: 1M2006040088-01-R1.ZNF	Test Dates: 06/25/20 – 08/05/20	DUT Type: Portable Handset		Page 85 of 159

**Table 9-87
5 GHz WLAN Maximum Average RF Power – Ant 1**

5GHz (20MHz) Conducted Power [dBm]				
Freq [MHz]	Channel	IEEE Transmission Mode		
		802.11a	802.11n	802.11ac
		Average	Average	Average
5180	36	16.44	16.26	16.33
5200	40	18.59	18.51	18.49
5220	44	16.53	16.37	16.38
5240	48	16.57	16.45	16.45
5260	52	16.48	16.38	16.34
5280	56	18.45	18.35	18.41
5300	60	16.37	16.25	16.19
5320	64	16.30	16.20	16.23
5500	100	16.72	16.55	16.53
5600	120	16.35	16.26	16.22
5620	124	16.45	16.33	16.40
5720	144	16.75	16.69	16.71
5745	149	16.81	16.70	16.65
5785	157	18.84	18.70	18.70
5825	165	18.60	18.62	18.61



FCC ID: ZNFG900VM	 PCTEST <small>Proud to be part of element</small>	SAR EVALUATION REPORT		Approved by: Quality Manager
Document S/N: 1M2006040088-01-R1.ZNF	Test Dates: 06/25/20 – 08/05/20	DUT Type: Portable Handset		Page 86 of 159

Table 9-88
5 GHz WLAN Maximum Average RF Power – Ant 2

5GHz (20MHz) Conducted Power [dBm]				
Freq [MHz]	Channel	IEEE Transmission Mode		
		802.11a	802.11n	802.11ac
		Average	Average	Average
5180	36	16.49	16.32	16.40
5200	40	18.59	18.48	18.51
5220	44	16.51	16.37	16.35
5240	48	16.51	16.41	16.38
5260	52	16.59	16.44	16.42
5280	56	18.53	18.47	18.46
5300	60	16.54	16.44	16.43
5320	64	16.60	16.44	16.45
5500	100	16.68	16.56	16.49
5600	120	16.54	16.42	16.37
5620	124	16.51	16.41	16.35
5720	144	16.50	16.44	16.40
5745	149	16.48	16.37	16.36
5785	157	18.42	18.37	18.31
5825	165	18.51	18.44	18.37

Table 9-89
5 GHz WLAN Reduced Average RF Power– Ant 1

5GHz (40MHz) Conducted Power [dBm]			
Freq [MHz]	Channel	IEEE Transmission Mode	
		802.11n	802.11ac
		Average	Average
5190	38	15.71	15.73
5230	46	15.70	15.66
5270	54	15.54	15.56
5310	62	15.33	15.34
5510	102	15.63	15.62
5590	118	15.76	15.68
5630	126	15.58	15.54
5710	142	15.92	15.90
5755	151	15.81	15.77
5795	159	15.93	15.98





FCC ID: ZNFG900VM	 PCTEST <small>Proud to be part of element</small>	SAR EVALUATION REPORT		Approved by: Quality Manager
Document S/N: 1M2006040088-01-R1.ZNF	Test Dates: 06/25/20 – 08/05/20	DUT Type: Portable Handset		Page 87 of 159

Table 9-90
5 GHz WLAN Reduced Average RF Power– Ant 2

5GHz (40MHz) Conducted Power [dBm]			
Freq [MHz]	Channel	IEEE Transmission Mode	
		802.11n	802.11ac
		Average	Average
5190	38	15.41	15.39
5230	46	15.48	15.53
5270	54	15.44	15.46
5310	62	15.59	15.72
5510	102	15.78	15.86
5590	118	15.60	15.65
5630	126	15.71	15.75
5710	142	15.71	15.66
5755	151	15.61	15.66
5795	159	15.66	15.71

Table 9-91
5 GHz WLAN Maximum Average RF Power – MIMO

5GHz (20MHz) 802.11n Conducted Power [dBm]				
Freq [MHz]	Channel	ANT1	ANT2	MIMO
5180	36	16.26	16.32	19.30
5200	40	18.51	18.48	21.51
5220	44	16.37	16.37	19.38
5240	48	16.45	16.41	19.44
5260	52	16.38	16.44	19.42
5280	56	18.35	18.47	21.42
5300	60	16.25	16.44	19.36
5320	64	16.20	16.44	19.33
5500	100	16.55	16.56	19.57
5600	120	16.26	16.42	19.35
5620	124	16.33	16.41	19.38
5720	144	16.69	16.44	19.58
5745	149	16.70	16.37	19.55
5785	157	18.70	18.37	21.55
5825	165	18.62	18.44	21.54

FCC ID: ZNFG900VM	 PCTEST Proud to be part of 	SAR EVALUATION REPORT	 LG	Approved by: Quality Manager
Document S/N: 1M2006040088-01-R1.ZNF	Test Dates: 06/25/20 – 08/05/20	DUT Type: Portable Handset		Page 88 of 159

**Table 9-92
5 GHz WLAN Reduced Average RF Power – MIMO**



5GHz (40MHz) 802.11n Conducted Power [dBm]				
Freq [MHz]	Channel	ANT1	ANT2	MIMO
5190	38	15.71	15.41	18.57
5230	46	15.70	15.48	18.60
5270	54	15.54	15.44	18.50
5310	62	15.33	15.59	18.47
5510	102	15.63	15.78	18.72
5590	118	15.76	15.60	18.69
5630	126	15.58	15.71	18.66
5710	142	15.92	15.71	18.83
5755	151	15.81	15.61	18.72
5795	159	15.93	15.66	18.81

Justification for test configurations for WLAN per KDB Publication 248227 D01v02r02:

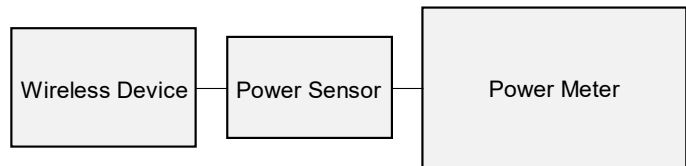
- Power measurements were performed for the transmission mode configuration with the highest maximum output power specified for production units.
- For transmission modes with the same maximum output power specification, powers were measured for the largest channel bandwidth, lowest order modulation and lowest data rate.
- For transmission modes with identical maximum specified output power, channel bandwidth, modulation and data rates, power measurements were required for all identical configurations.
- For each transmission mode configuration, powers were measured for the highest and lowest channels; and at the mid-band channel(s) when there were at least 3 channels supported. For configurations with multiple mid-band channels, due to an even number of channels, both channels were measured.





**Figure 9-5
Power Measurement Setup**

FCC ID: ZNFG900VM	 <small>Proud to be part of element</small>	SAR EVALUATION REPORT		Approved by: Quality Manager
Document S/N: 1M2006040088-01-R1.ZNF	Test Dates: 06/25/20 – 08/05/20	DUT Type: Portable Handset	Page 89 of 159	

9.7 Bluetooth Conducted Powers

Table 9-93
Bluetooth Average RF Power

Frequency [MHz]	Data Rate [Mbps]	Channel No.	Avg Conducted Power	
			[dBm]	[mW]
2402	1.0	0	10.31	10.741
2441	1.0	39	11.36	13.684
2480	1.0	78	10.29	10.686
2402	2.0	0	9.72	9.368
2441	2.0	39	10.78	11.959
2480	2.0	78	9.77	9.475
2402	3.0	0	9.76	9.467
2441	3.0	39	10.82	12.081
2480	3.0	78	9.76	9.470

FCC ID: ZNFG900VM	 PCTEST Proud to be part of 	SAR EVALUATION REPORT		Approved by: Quality Manager
Document S/N: 1M2006040088-01-R1.ZNF	Test Dates: 06/25/20 – 08/05/20	DUT Type: Portable Handset		Page 90 of 159

**Figure 9-6
Bluetooth Transmission Plot**

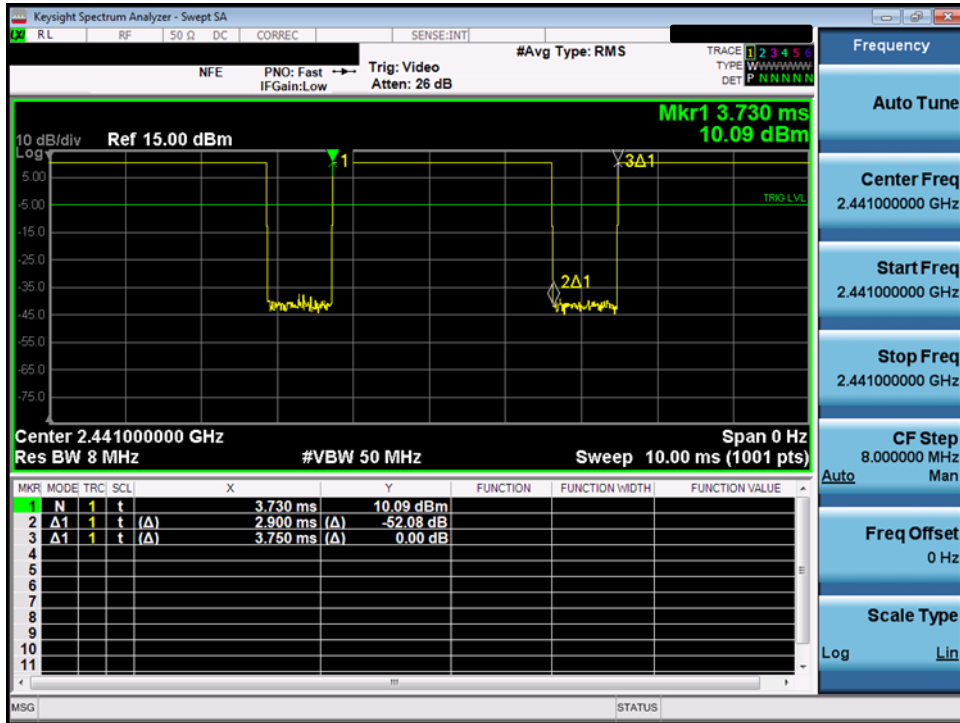

**Equation 9-1
Bluetooth Duty Cycle Calculation**

$$Duty\ Cycle = \frac{Pulse\ Width}{Period} * 100\% = \frac{2.90\ ms}{3.75\ ms} * 100\% = 77.3\%$$

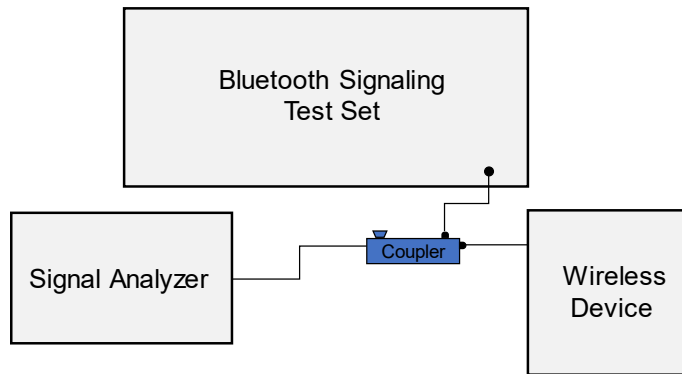

**Figure 9-7
Power Measurement Setup**



FCC ID: ZNFG900VM	 Proud to be part of element	SAR EVALUATION REPORT		Approved by: Quality Manager
Document S/N: 1M2006040088-01-R1.ZNF	Test Dates: 06/25/20 – 08/05/20	DUT Type: Portable Handset		Page 91 of 159

10 SYSTEM VERIFICATION

10.1 Tissue Verification

**Table 10-1
Measured Tissue Properties - Head**



Calibrated for Tests Performed on:	Tissue Type	Tissue Temp During Calibration (°C)	Measured Frequency (MHz)	Measured Conductivity, σ (S/m)	Measured Dielectric Constant, ε	TARGET Conductivity, σ (S/m)	TARGET Dielectric Constant, ε	% dev σ	% dev ε
07/05/2020	750 Head	21.9	700	0.864	43.105	0.889	42.201	-2.81%	2.28%
			710	0.869	43.144	0.890	42.149	-2.36%	2.36%
			725	0.875	43.111	0.891	42.071	-1.80%	2.47%
			750	0.883	43.064	0.894	41.942	-1.23%	2.65%
			770	0.887	43.007	0.895	41.838	-0.85%	2.75%
06/29/2020	835 Head	22.1	785	0.891	42.948	0.896	41.760	-0.56%	2.84%
			820	0.891	41.952	0.899	41.578	-0.89%	0.90%
			835	0.908	41.748	0.900	41.500	0.67%	0.82%
07/02/2020	1750 Head	22.7	850	0.922	41.536	0.916	41.500	0.66%	0.11%
			1710	1.289	40.843	1.348	40.142	-4.38%	1.75%
			1720	1.298	40.807	1.354	40.126	-4.28%	1.75%
			1745	1.311	40.800	1.368	40.087	-4.17%	1.78%
			1750	1.314	40.794	1.371	40.079	-4.16%	1.78%
06/26/2020	1900 Head	21.3	1770	1.325	40.764	1.383	40.047	-4.19%	1.79%
			1790	1.335	40.730	1.394	40.016	-4.23%	1.79%
			1850	1.370	40.338	1.400	40.000	-2.14%	0.85%
			1860	1.376	40.327	1.400	40.000	-1.71%	0.82%
			1880	1.388	40.304	1.400	40.000	-0.86%	0.76%
			1900	1.401	40.275	1.400	40.000	0.07%	0.65%
			1905	1.404	40.268	1.400	40.000	0.29%	0.67%
07/03/2020	1900 Head	21.3	1910	1.407	40.260	1.400	40.000	0.50%	0.65%
			1850	1.340	40.157	1.400	40.000	-4.25%	0.39%
			1860	1.346	40.142	1.400	40.000	-3.85%	0.36%
			1880	1.359	40.110	1.400	40.000	-3.93%	0.27%
			1900	1.371	40.081	1.400	40.000	-3.07%	0.20%
06/28/2020	2450 Head	22.3	1905	1.374	40.076	1.400	40.000	-1.86%	0.19%
			1910	1.377	40.069	1.400	40.000	-1.64%	0.17%
			2400	1.781	41.165	1.758	39.289	-1.42%	4.17%
			2450	1.821	41.109	1.800	39.200	-1.17%	4.67%
			2480	1.843	41.090	1.833	39.162	0.55%	4.65%
07/15/2020	2450 Head	22.5	2500	1.857	41.050	1.855	39.136	0.11%	4.89%
			2400	1.784	38.745	1.756	39.289	2.16%	-1.38%
			2450	1.845	38.576	1.800	39.200	2.92%	-1.58%
07/24/2020	3600 Head	22.4	2480	1.877	38.473	1.833	39.162	2.40%	-1.76%
			2500	1.899	38.404	1.855	39.136	2.37%	-1.87%
			3550	2.872	39.373	2.913	37.929	-1.41%	3.81%
			3550	2.913	39.319	2.964	37.871	-1.72%	3.61%
			3550	2.922	39.303	2.974	37.860	-1.75%	3.51%
			3600	2.953	39.244	3.015	37.814	-2.06%	3.79%
			3650	2.997	39.191	3.066	37.757	-2.25%	3.80%
			3690	3.028	39.139	3.107	37.711	-2.54%	3.73%
			3700	3.037	39.104	3.117	37.700	-2.57%	3.72%
			5180	4.513	35.877	4.635	36.009	-2.63%	-0.37%
06/25/2020	5200-5800 Head	21.8	5190	4.521	35.857	4.645	35.998	-2.67%	-0.39%
			5200	4.530	35.848	4.655	35.986	-2.69%	-0.38%
			5210	4.542	35.836	4.666	35.975	-2.69%	-0.39%
			5220	4.554	35.818	4.676	35.963	-2.61%	-0.40%
			5240	4.574	35.786	4.696	35.940	-2.60%	-0.43%
			5250	4.584	35.782	4.706	35.929	-2.59%	-0.41%
			5260	4.594	35.772	4.717	35.917	-2.61%	-0.40%
			5270	4.603	35.763	4.727	35.906	-2.62%	-0.40%
			5280	4.612	35.749	4.737	35.894	-2.64%	-0.40%
			5290	4.623	35.728	4.748	35.883	-2.63%	-0.44%
			5300	4.633	35.711	4.758	35.871	-2.63%	-0.45%
			5310	4.641	35.696	4.768	35.860	-2.66%	-0.46%
			5320	4.651	35.685	4.778	35.849	-2.66%	-0.46%
			5500	4.831	35.417	4.963	35.643	-2.66%	-0.63%
			5510	4.841	35.407	4.973	35.632	-2.65%	-0.63%
			5520	4.852	35.401	4.983	35.620	-2.63%	-0.61%
			5530	4.861	35.388	4.994	35.609	-2.66%	-0.62%
			5540	4.872	35.379	5.004	35.597	-2.64%	-0.64%
			5550	4.884	35.358	5.014	35.586	-2.59%	-0.65%
			5560	4.896	35.339	5.024	35.574	-2.55%	-0.66%
			5580	4.917	35.301	5.045	35.551	-2.54%	-0.70%
			5600	4.936	35.279	5.065	35.529	-2.55%	-0.70%
			5610	4.945	35.268	5.076	35.518	-2.58%	-0.70%
			5620	4.955	35.250	5.086	35.506	-2.58%	-0.72%
			5640	4.979	35.211	5.106	35.483	-2.49%	-0.77%
5660	5.002	35.183	5.127	35.460	-2.44%	-0.78%			
5670	5.012	35.166	5.137	35.449	-2.43%	-0.80%			
5680	5.022	35.154	5.147	35.437	-2.43%	-0.80%			
5690	5.033	35.142	5.158	35.426	-2.42%	-0.80%			
5700	5.045	35.127	5.168	35.414	-2.38%	-0.81%			
5710	5.058	35.102	5.178	35.403	-2.32%	-0.85%			
5720	5.071	35.078	5.188	35.391	-2.26%	-0.89%			
5745	5.100	35.023	5.214	35.363	-2.19%	-0.88%			
5750	5.105	35.051	5.219	35.357	-2.18%	-0.87%			
5755	5.111	35.048	5.224	35.351	-2.16%	-0.88%			
5765	5.122	35.038	5.234	35.340	-2.14%	-0.85%			
5775	5.138	35.028	5.245	35.329	-2.04%	-0.85%			
5785	5.153	35.009	5.255	35.317	-1.94%	-0.87%			
5795	5.163	34.988	5.265	35.305	-1.84%	-0.90%			
5800	5.165	34.974	5.270	35.300	-1.89%	-0.92%			
5805	5.168	34.965	5.275	35.294	-2.07%	-0.93%			
5825	5.189	34.954	5.296	35.271	-2.02%	-0.90%			
5500	4.782	35.624	4.963	35.643	-3.65%	0.51%			
5510	4.795	35.606	4.973	35.632	-3.58%	0.49%			
5520	4.806	35.788	4.983	35.620	-3.55%	0.47%			
5530	4.815	35.770	4.994	35.609	-3.58%	0.45%			
5540	4.824	35.759	5.004	35.597	-3.62%	0.46%			
5550	4.834	35.748	5.014	35.586	-3.59%	0.46%			
5560	4.846	35.729	5.024	35.574	-3.54%	0.44%			
5580	4.870	35.688	5.045	35.551	-3.47%	0.38%			
5600	4.889	35.665	5.065	35.529	-3.47%	0.36%			
5610	4.899	35.637	5.076	35.518	-3.46%	0.34%			
5620	4.910	35.615	5.086	35.506	-3.46%	0.31%			
5640	4.936	35.580	5.106	35.483	-3.33%	0.27%			
5660	4.963	35.558	5.127	35.460	-3.20%	0.30%			
5670	4.972	35.558	5.137	35.449	-3.21%	0.31%			
5680	4.979	35.546	5.147	35.437	-3.26%	0.31%			
5690	4.991	35.533	5.158	35.426	-3.24%	0.30%			
5700	5.004	35.519	5.168	35.414	-3.17%	0.30%			

FCC ID: ZNFG900VM	 PCTEST Proud to be part of  element	SAR EVALUATION REPORT		Approved by: Quality Manager
Document S/N: 1M2006040088-01-R1-ZNF	Test Dates: 06/25/20 – 08/05/20	DUT Type: Portable Handset		Page 92 of 159

**Table 10-2
Measured Tissue Properties – Body**

Calibrated for Test Performance	Tissue Type	Tissue Temp During Calibration (°C)	Measured Frequency (MHz)	Measured Conductivity σ (S/m)	Measured Dielectric Constant ε (S/m)	TARGET Dielectric Constant ε	TARGET Dielectric Constant ε	%dev σ	%dev ε
07010200	750 Body	21.8	700	0.940	54.063	0.960	55.728	-3.40%	-2.64%
			725	0.945	54.023	0.961	55.620	-1.68%	-2.88%
			750	0.955	53.955	0.964	55.631	-0.93%	-2.62%
			770	0.952	53.924	0.965	55.453	-0.91%	-2.76%
			785	0.967	53.924	0.966	55.395	0.10%	-2.66%
07010200	835 Body	21.5	800	0.948	53.423	0.969	55.255	-3.47%	-3.32%
			835	0.952	53.263	0.970	55.200	-1.86%	-3.51%
			850	0.959	53.154	0.988	55.154	-1.82%	-3.72%
			860	0.956	53.000	0.989	55.205	-3.81%	-3.62%
			870	0.951	53.927	0.970	55.200	-1.95%	-2.91%
07040200	835 Body	21.3	800	0.967	53.903	0.988	55.154	-2.13%	-2.99%
			820	0.928	54.697	0.969	55.205	-3.81%	-1.02%
			835	0.951	54.539	0.970	55.200	-1.95%	-1.20%
			850	0.967	54.389	0.988	55.154	-2.13%	-1.39%
			870	0.977	53.969	0.989	55.205	0.63%	-2.33%
72202000	835 Body	21.5	800	0.983	53.925	0.970	55.200	1.34%	-2.11%
			850	0.990	53.885	0.988	55.154	0.20%	-2.30%
			1710	1.452	51.859	1.463	53.537	-0.75%	-3.48%
			1720	1.464	51.820	1.466	53.511	-0.26%	-3.25%
			1745	1.452	51.933	1.485	53.445	0.47%	-3.58%
07070200	1750 Body	21.2	1750	1.497	51.513	1.488	53.432	0.60%	-3.95%
			1770	1.511	51.434	1.501	53.376	0.76%	-3.66%
			1790	1.528	51.358	1.514	53.325	1.69%	-3.65%
			1710	1.480	51.545	1.463	53.537	1.16%	-3.52%
			1720	1.491	51.611	1.489	53.511	0.60%	-3.55%
07190200	1750 Body	21.7	1745	1.519	51.507	1.485	53.445	2.29%	-3.62%
			1750	1.524	51.487	1.488	53.432	2.42%	-3.40%
			1770	1.536	51.410	1.501	53.376	3.00%	-3.89%
			1790	1.550	51.341	1.514	53.320	3.18%	-3.72%
			1710	1.467	51.718	1.463	53.537	0.27%	-3.40%
08050200	1750 Body	22.4	1720	1.478	51.679	1.489	53.511	0.61%	-3.42%
			1744	1.490	51.590	1.485	53.445	0.35%	-3.26%
			1750	1.511	51.574	1.488	53.432	1.65%	-3.48%
			1770	1.522	51.509	1.501	53.376	2.07%	-3.51%
			1790	1.534	51.436	1.514	53.320	2.64%	-3.45%
07140200	1900 Body	23.1	1880	1.500	53.884	1.520	53.300	-1.32%	-0.78%
			1880	1.512	53.850	1.520	53.300	-0.83%	-0.84%
			1880	1.524	53.790	1.520	53.300	-0.92%	-0.88%
			1900	1.520	53.725	1.520	53.300	-2.97%	-1.07%
			1905	1.562	53.713	1.520	53.300	2.78%	-1.10%
07210200	1900 Body	21.5	1910	1.568	53.697	1.520	53.300	3.66%	-1.12%
			1890	1.521	53.381	1.520	53.300	0.07%	-1.72%
			1880	1.532	53.345	1.520	53.300	0.79%	-1.73%
			1880	1.554	53.277	1.520	53.300	2.24%	-1.90%
			1900	1.576	53.214	1.520	53.300	3.68%	-1.84%
07220200	1900 Body	23.5	1905	1.592	53.199	1.520	53.300	4.68%	-2.07%
			1910	1.607	53.163	1.520	53.300	6.11%	-2.10%
			1880	1.509	54.041	1.520	53.300	-0.72%	1.95%
			1880	1.520	54.013	1.520	53.300	0.00%	1.34%
			1880	1.542	53.956	1.520	53.300	1.48%	1.22%
08030200	1900 Body	23.6	1905	1.564	53.890	1.520	53.300	2.81%	1.11%
			1905	1.570	53.871	1.520	53.300	3.29%	1.07%
			1910	1.575	53.855	1.520	53.300	3.62%	1.04%
			1880	1.506	53.966	1.520	53.300	-0.82%	-1.21%
			1880	1.510	53.920	1.520	53.300	-0.28%	-1.30%
08050200	1900 Body	23.9	1880	1.540	53.492	1.520	53.300	1.32%	-1.82%
			1900	1.561	53.416	1.520	53.300	2.70%	-1.65%
			1905	1.568	53.415	1.520	53.300	3.16%	-1.66%
			1910	1.573	53.400	1.520	53.300	3.49%	-1.67%
			1880	1.571	53.399	1.520	53.300	4.65%	-2.08%
08050200	1900 Body	23.9	1880	1.524	53.154	1.520	53.300	0.26%	-2.18%
			1880	1.547	53.092	1.520	53.300	1.78%	-2.29%
			1900	1.566	53.007	1.520	53.300	3.22%	-2.40%
			1905	1.575	52.985	1.520	53.300	3.62%	-2.47%
			1910	1.580	52.965	1.520	53.300	3.85%	-2.50%
07070200	2450 Body	21.7	2450	2.093	51.029	1.993	52.700	4.20%	-3.04%
			2480	2.067	51.007	1.993	52.662	3.71%	-3.14%
			2500	2.089	50.944	2.021	52.636	3.88%	-3.21%
			2480	1.984	51.084	1.993	52.762	4.91%	-3.12%
			2460	2.045	50.954	1.990	52.700	4.67%	-3.31%
07140200	2450 Body	22.6	2480	2.079	50.962	1.993	52.662	4.32%	-3.42%
			2500	2.100	50.791	2.021	52.636	4.65%	-3.51%
			2460	2.048	50.334	2.021	51.221	1.03%	-3.87%
			2460	2.068	49.242	2.021	51.254	0.77%	-3.93%
			2460	2.111	49.232	2.021	51.240	0.80%	-3.92%
07210200	3000 Body	23.7	3000	3.451	48.195	3.431	51.108	0.58%	-3.89%
			3050	3.489	48.159	3.489	51.118	0.29%	-3.92%
			3060	3.493	48.099	3.508	51.061	0.26%	-3.96%
			3100	3.554	48.027	3.548	51.090	0.17%	-3.96%
			3180	3.546	48.459	3.576	49.041	1.31%	-1.19%
07220200	3000 Body	23.7	3190	3.566	48.499	3.586	49.038	1.40%	-1.20%
			3200	3.578	48.421	3.599	49.014	1.49%	-1.21%
			3210	3.595	48.363	3.611	49.001	1.68%	-1.24%
			3220	3.612	48.374	3.623	48.987	1.67%	-1.25%
			3240	3.651	48.343	3.636	48.962	1.65%	-1.26%
07290200	5200-6800 Body	22.6	5200	5.470	48.324	5.386	48.941	2.69%	-1.27%
			5280	5.487	48.284	5.389	48.933	2.20%	-1.32%
			5370	5.504	48.254	5.381	48.918	2.20%	-1.36%
			5280	5.521	48.238	5.393	48.906	2.37%	-1.37%
			5300	5.541	48.222	5.404	48.892	2.64%	-1.37%
07300200	5200-6800 Body	22.6	5320	5.559	48.205	5.416	48.879	2.64%	-1.38%
			5330	5.579	48.194	5.428	48.865	2.78%	-1.37%
			5320	5.601	48.187	5.439	48.851	2.98%	-1.36%
			5350	5.588	47.999	5.650	48.607	3.50%	-1.26%
			5310	5.650	47.978	5.661	48.594	3.62%	-1.27%
07310200	5200-6800 Body	22.6	5320	5.670	47.967	5.673	48.580	3.47%	-1.26%
			5340	5.677	47.969	5.685	48.568	3.36%	-1.24%
			5340	5.685	47.951	5.696	48.553	3.32%	-1.24%
			5350	5.694	47.930	5.708	48.539	3.25%	-1.23%
			5350	5.679	47.914	5.720	48.525	3.20%	-1.24%
07320200	5200-6800 Body	22.6	5360	5.677	47.881	5.743	48.490	3.08%	-1.27%
			5360	5.635	47.832	5.765	48.471	2.93%	-1.32%
			5310	5.643	47.811	5.778	48.458	2.86%	-1.34%
			5320	5.640	47.792	5.790	48.444	2.75%	-1.34%
			5340	5.676	47.790	5.813	48.417	2.80%	-1.38%
07330200	5200-6800 Body	22.6	5360	5.632	47.719	5.837	48.390	2.83%	-1.39%
			5370	5.611	47.710	5.848	48.376	2.79%	-1.38%
			5380	5.610	47.691	5.860	48.363	2.71%	-1.39%
			5390	5.632	47.655	5.872	48.349	2.72%	-1.44%
			5390	5.644	47.614	5.883	48.338	2.74%	-1.49%
07340200	5200-6800 Body	22.6	5370	5.651	47.577	5.895	48.322	2.62%	-1.54%
			5370	5.679	47.555	5.907	48.309	2.61%	-1.56%
			5370	5.670	47.511	5.936	48.273	3.10%	-1.57%
			5390	5.672	47.515	5.942	48.268	3.11%	-1.56%
			5375	5.670	47.512	5.947	48.261	3.18%	-1.55%
07350200	5200-6800 Body	22.6	5375	5.690	47.499	5.959	48.245	3.21%	-1.56%
			5375	5.699	47.481	5.971	48.234	3.32%	-1.60%
			5375	5.690	47.418	5.982	48.220	3.48%	-1.56%
			5375	5.711	47.399	5.994	48.207	3.62%	-1.72%
			5380	5.625	47.371	6.000	48.200	3.72%	-1.72%
07360200	5200-6800 Body	22.6	5385	5.631	47.369	6.006	48.193	3.75%	-1.73%
			5385	5.620	47.315	6.029	48.186	3.88%	-1.77%

The above measured tissue parameters were used in the DASY software. The DASY software was used to perform interpolation to determine the dielectric parameters at the SAR test device frequencies (per KDB Publication 865664 D01v01r04 and IEEE 1528-2013 6.6.1.2). The tissue parameters listed in the SAR test plots may slightly differ from the table above due to significant digit rounding in the software.



FCC ID: ZNFG900VM	 PCTEST Proud to be part of element	SAR EVALUATION REPORT		Approved by: Quality Manager
Document S/N: 1M2006040088-01-R1-ZNF	Test Dates: 06/25/20 – 08/05/20	DUT Type: Portable Handset	Page 93 of 159	

10.2 Test System Verification

Prior to SAR assessment, the system is verified to $\pm 10\%$ of the SAR measurement on the reference dipole at the time of calibration by the calibration facility. Full system validation status and result summary can be found in Appendix D.

**Table 10-3
System Verification Results – 1g**

System Verification TARGET & MEASURED												
SAR System #	Tissue Frequency (MHz)	Tissue Type	Date	Amb. Temp (°C)	Liquid Temp (°C)	Input Power (W)	Source SN	Probe SN	Measured SAR _{1g} (W/kg)	1 W Target SAR _{1g} (W/kg)	1 W Normalized SAR _{1g} (W/kg)	Deviation _{1g} (%)
E	750	HEAD	07/05/2020	20.3	21.9	0.200	1003	3589	1.670	8.780	8.350	-4.90%
L	835	HEAD	06/29/2020	23.1	21.9	0.200	4d132	7410	1.920	9.650	9.600	-0.52%
E	1750	HEAD	07/02/2020	23.1	22.7	0.100	1150	3589	3.390	36.500	33.900	-7.12%
L	1900	HEAD	06/26/2020	24.6	21.8	0.100	5d148	7410	4.120	39.100	41.200	5.37%
L	1900	HEAD	07/03/2020	23.4	21.3	0.100	5d148	7410	4.170	39.100	41.700	6.65%
E	2450	HEAD	06/28/2020	22.9	22.3	0.100	719	3589	5.340	53.100	53.400	0.56%
RK	2450	HEAD	07/15/2020	22.0	22.5	0.100	882	7565	5.230	52.900	52.300	-1.13%
D	3500	HEAD	07/24/2020	22.8	22.4	0.100	1059	7488	6.180	64.600	61.800	-4.33%
RK	5250	HEAD	06/25/2020	21.8	21.3	0.050	1120	7402	3.900	80.300	78.000	-2.86%
RK	5600	HEAD	06/29/2020	21.5	20.5	0.050	1120	7402	3.960	83.600	79.200	-5.26%
RK	5750	HEAD	06/25/2020	21.8	21.3	0.050	1120	7402	3.780	80.400	75.600	-5.97%
L	750	BODY	07/01/2020	23.7	22.0	0.200	1054	7410	1.800	8.530	9.000	5.51%
P	835	BODY	07/01/2020	22.9	21.8	0.200	4d132	7551	1.990	9.960	9.950	-0.10%
P	835	BODY	07/04/2020	21.9	21.9	0.200	4d132	7551	1.980	9.960	9.900	-0.60%
P	835	BODY	07/06/2020	22.0	21.7	0.200	4d132	7551	2.020	9.960	10.100	1.41%
P	835	BODY	07/22/2020	22.7	21.5	0.200	4d047	7551	2.020	9.470	10.100	6.65%
I	1750	BODY	07/07/2020	23.2	21.2	0.100	1008	7570	3.550	37.400	35.500	-5.08%
P	1750	BODY	07/19/2020	23.5	21.3	0.100	1150	7551	3.900	36.600	39.000	6.56%
I	1750	BODY	08/05/2020	22.3	22.4	0.100	1008	7570	3.930	37.400	39.300	5.08%
J	1900	BODY	07/14/2020	24.0	23.1	0.100	5d080	7571	4.160	39.200	41.600	6.12%
H	1900	BODY	07/21/2020	23.0	21.5	0.100	5d080	7357	4.200	39.200	42.000	7.14%
J	1900	BODY	07/22/2020	22.7	23.5	0.100	5d080	7571	4.270	39.200	42.700	8.93%
H	1900	BODY	08/03/2020	24.4	22.5	0.100	5d149	7357	4.250	39.400	42.500	7.87%
RK	2450	BODY	07/07/2020	21.0	22.5	0.100	882	7565	5.080	51.500	50.800	-1.36%
K	2450	BODY	07/14/2020	23.0	21.6	0.100	719	7409	4.930	50.800	49.300	-2.95%
D	3500	BODY	07/21/2020	24.2	23.7	0.100	1059	7488	6.600	65.100	66.000	1.38%
RK	5250	BODY	07/02/2020	22.6	21.0	0.050	1120	7402	3.590	74.800	71.800	-4.01%
RK	5600	BODY	07/02/2020	22.6	21.0	0.050	1120	7402	3.920	78.000	78.400	0.51%
RK	5750	BODY	07/02/2020	22.6	21.0	0.050	1120	7402	3.680	75.000	73.600	-1.87%

FCC ID: ZNFG900VM	 PCTEST Proud to be part of  element	SAR EVALUATION REPORT	 LG	Approved by: Quality Manager
Document S/N: 1M2006040088-01-R1.ZNF	Test Dates: 06/25/20 – 08/05/20	DUT Type: Portable Handset	Page 94 of 159	

**Table 10-4
System Verification Results – 10g**

System Verification TARGET & MEASURED												
SAR System #	Tissue Frequency (MHz)	Tissue Type	Date	Amb. Temp (°C)	Liquid Temp (°C)	Input Power (W)	Source SN	Probe SN	Measured SAR _{10g} (W/kg)	1 W Target SAR _{10g} (W/kg)	1 W Normalized SAR _{10g} (W/kg)	Deviation _{10g} (%)
I	1750	BODY	08/05/2020	22.3	22.4	0.100	1008	7570	2.060	19.900	20.600	3.52%
H	1900	BODY	08/03/2020	24.4	22.5	0.100	5d149	7357	2.200	20.700	22.000	6.28%
H	1900	BODY	08/05/2020	24.5	23.5	0.100	5d080	7357	2.080	20.600	20.800	0.97%
RK	5250	BODY	07/02/2020	22.6	21.0	0.050	1120	7402	1.040	20.900	20.800	-0.48%
RK	5600	BODY	07/02/2020	22.6	21.0	0.050	1120	7402	1.080	21.600	21.600	0.00%
RK	5750	BODY	07/02/2020	22.6	21.0	0.050	1120	7402	1.110	20.900	22.200	6.22%

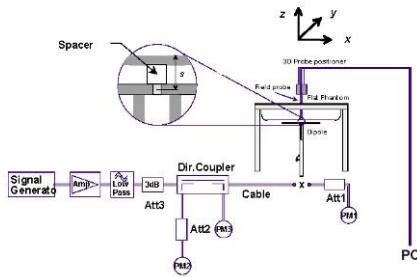

**Figure 10-1
System Verification Setup Diagram**



**Figure 10-2
System Verification Setup Photo**

FCC ID: ZNFG900VM	 Proud to be part of	SAR EVALUATION REPORT		Approved by: Quality Manager
Document S/N: 1M2006040088-01-R1.ZNF	Test Dates: 06/25/20 – 08/05/20	DUT Type: Portable Handset		Page 95 of 159

11 SAR DATA SUMMARY



11.1 Standalone Head SAR Data

**Table 11-1
GSM 850 Head SAR**

MEASUREMENT RESULTS															
FREQUENCY		Mode	Service	Maximum Allowed Power [dBm]	Conducted Power [dBm]	Power Drift [dB]	Side	Test Position	Device Serial Number	# of Time Slots	Duty Cycle	SAR (1g)	Scaling Factor	Reported SAR (1g)	Plot #
MHz	Ch.											(W/kg)		(W/kg)	
836.60	190	GSM 850	GSM	33.5	33.12	0.03	Right	Cheek	04914	1	1:8.3	0.087	1.091	0.095	
836.60	190	GSM 850	GSM	33.5	33.12	0.13	Right	Tilt	04914	1	1:8.3	0.051	1.091	0.056	
836.60	190	GSM 850	GSM	33.5	33.12	0.04	Left	Cheek	04914	1	1:8.3	0.113	1.091	0.123	
836.60	190	GSM 850	GSM	33.5	33.12	0.10	Left	Tilt	04914	1	1:8.3	0.050	1.091	0.055	
836.60	190	GSM 850	GPRS	32.0	31.43	-0.16	Right	Cheek	04914	2	1:4.15	0.131	1.140	0.149	
836.60	190	GSM 850	GPRS	32.0	31.43	-0.17	Right	Tilt	04914	2	1:4.15	0.073	1.140	0.083	
836.60	190	GSM 850	GPRS	32.0	31.43	-0.08	Left	Cheek	04914	2	1:4.15	0.164	1.140	0.187	A1
836.60	190	GSM 850	GPRS	32.0	31.43	-0.16	Left	Tilt	04914	2	1:4.15	0.071	1.140	0.081	
ANSI / IEEE C95.1 1992 - SAFETY LIMIT Spatial Peak Uncontrolled Exposure/General Population								Head 1.6 W/kg (mW/g) averaged over 1 gram							

**Table 11-2
GSM 1900 Head SAR**

MEASUREMENT RESULTS															
FREQUENCY		Mode	Service	Maximum Allowed Power [dBm]	Conducted Power [dBm]	Power Drift [dB]	Side	Test Position	Device Serial Number	# of Time Slots	Duty Cycle	SAR (1g)	Scaling Factor	Reported SAR (1g)	Plot #
MHz	Ch.											(W/kg)		(W/kg)	
1880.00	661	GSM 1900	GSM	30.5	29.84	0.19	Right	Cheek	04914	1	1:8.3	0.043	1.164	0.050	
1880.00	661	GSM 1900	GSM	30.5	29.84	0.11	Right	Tilt	04914	1	1:8.3	0.016	1.164	0.019	
1880.00	661	GSM 1900	GSM	30.5	29.84	0.03	Left	Cheek	04914	1	1:8.3	0.043	1.164	0.050	
1880.00	661	GSM 1900	GSM	30.5	29.84	0.13	Left	Tilt	04914	1	1:8.3	0.028	1.164	0.033	
1880.00	661	GSM 1900	GPRS	29.0	28.99	0.12	Right	Cheek	04914	2	1:4.15	0.056	1.002	0.056	
1880.00	661	GSM 1900	GPRS	29.0	28.99	-0.15	Right	Tilt	04914	2	1:4.15	0.022	1.002	0.022	
1880.00	661	GSM 1900	GPRS	29.0	28.99	0.01	Left	Cheek	04914	2	1:4.15	0.063	1.002	0.063	A2
1880.00	661	GSM 1900	GPRS	29.0	28.99	0.13	Left	Tilt	04914	2	1:4.15	0.040	1.002	0.040	
ANSI / IEEE C95.1 1992 - SAFETY LIMIT Spatial Peak Uncontrolled Exposure/General Population								Head 1.6 W/kg (mW/g) averaged over 1 gram							

FCC ID: ZNFG900VM	 PCTEST Proud to be part of 	SAR EVALUATION REPORT		Approved by: Quality Manager
Document S/N: 1M2006040088-01-R1.ZNF	Test Dates: 06/25/20 – 08/05/20	DUT Type: Portable Handset		Page 96 of 159

**Table 11-3
UMTS 850 Head SAR**



MEASUREMENT RESULTS															
FREQUENCY		Mode	Service	Maximum Allowed Power [dBm]	Conducted Power [dBm]	Power Drift [dB]	Side	Test Position	Antenna State	Device Serial Number	Duty Cycle	SAR (1g)	Scaling Factor	Reported SAR (1g)	Plot #
MHz	Ch.											(W/kg)		(W/kg)	
836.60	4183	UMTS 850	RMC	25.5	25.28	0.06	Right	Cheek	8	04914	1:1	0.157	1.052	0.165	
836.60	4183	UMTS 850	RMC	25.5	25.28	0.17	Right	Tilt	8	04914	1:1	0.084	1.052	0.088	
836.60	4183	UMTS 850	RMC	25.5	25.28	0.02	Left	Cheek	8	04914	1:1	0.202	1.052	0.213	A3
836.60	4183	UMTS 850	RMC	25.5	25.28	0.19	Left	Tilt	8	04914	1:1	0.073	1.052	0.077	
ANSI / IEEE C95.1 1992 - SAFETY LIMIT Spatial Peak Uncontrolled Exposure/General Population							Head 1.6 W/kg (mW/g) averaged over 1 gram								

**Table 11-4
UMTS 1900 Head SAR**

MEASUREMENT RESULTS															
FREQUENCY		Mode	Service	Maximum Allowed Power [dBm]	Conducted Power [dBm]	Power Drift [dB]	Side	Test Position	Antenna State	Device Serial Number	Duty Cycle	SAR (1g)	Scaling Factor	Reported SAR (1g)	Plot #
MHz	Ch.											(W/kg)		(W/kg)	
1880.00	9400	UMTS 1900	RMC	25.5	25.25	-0.12	Right	Cheek	04922	1:1	0.109	1.059	0.115	A4	
1880.00	9400	UMTS 1900	RMC	25.5	25.25	0.21	Right	Tilt	04922	1:1	0.038	1.059	0.040		
1880.00	9400	UMTS 1900	RMC	25.5	25.25	0.21	Left	Cheek	04922	1:1	0.104	1.059	0.110		
1880.00	9400	UMTS 1900	RMC	25.5	25.25	0.13	Left	Tilt	04922	1:1	0.069	1.059	0.073		
ANSI / IEEE C95.1 1992 - SAFETY LIMIT Spatial Peak Uncontrolled Exposure/General Population							Head 1.6 W/kg (mW/g) averaged over 1 gram								

**Table 11-5
Cell. CDMA Head SAR**

MEASUREMENT RESULTS															
FREQUENCY		Mode	Service	Maximum Allowed Power [dBm]	Conducted Power [dBm]	Power Drift [dB]	Side	Test Position	Antenna State	Device Serial Number	Duty Cycle	SAR (1g)	Scaling Factor	Reported SAR (1g)	Plot #
MHz	Ch.											(W/kg)		(W/kg)	
836.52	384	Cell. CDMA	RC3 / SO55	25.5	25.44	0.03	Right	Cheek	8	04914	1:1	0.169	1.014	0.171	
836.52	384	Cell. CDMA	RC3 / SO55	25.5	25.44	0.20	Right	Tilt	8	04914	1:1	0.093	1.014	0.094	
836.52	384	Cell. CDMA	RC3 / SO55	25.5	25.44	0.04	Left	Cheek	8	04914	1:1	0.188	1.014	0.191	A5
836.52	384	Cell. CDMA	RC3 / SO55	25.5	25.44	0.02	Left	Tilt	8	04914	1:1	0.072	1.014	0.073	
836.52	384	Cell. CDMA	EVDO Rev. A	25.5	24.83	-0.07	Right	Cheek	8	04914	1:1	0.140	1.167	0.163	
836.52	384	Cell. CDMA	EVDO Rev. A	25.5	24.83	0.12	Right	Tilt	8	04914	1:1	0.074	1.167	0.086	
836.52	384	Cell. CDMA	EVDO Rev. A	25.5	24.83	-0.03	Left	Cheek	8	04914	1:1	0.165	1.167	0.193	
836.52	384	Cell. CDMA	EVDO Rev. A	25.5	24.83	0.02	Left	Tilt	8	04914	1:1	0.071	1.167	0.083	
ANSI / IEEE C95.1 1992 - SAFETY LIMIT Spatial Peak Uncontrolled Exposure/General Population							Head 1.6 W/kg (mW/g) averaged over 1 gram								

FCC ID: ZNFG900VM	 PCTEST Proud to be part of element	SAR EVALUATION REPORT		Approved by: Quality Manager
Document S/N: 1M2006040088-01-R1.ZNF	Test Dates: 06/25/20 – 08/05/20	DUT Type: Portable Handset		Page 97 of 159

**Table 11-6
PCS CDMA Head SAR**



MEASUREMENT RESULTS														
FREQUENCY		Mode	Service	Maximum Allowed Power [dBm]	Conducted Power [dBm]	Power Drift [dB]	Side	Test Position	Device Serial Number	Duty Cycle	SAR (1g)	Scaling Factor	Reported SAR (1g)	Plot #
MHz	Ch.										(W/kg)		(W/kg)	
1880.00	600	PCS CDMA	RC3 / SO55	25.5	25.44	0.16	Right	Cheek	04914	1:1	0.069	1.014	0.070	
1880.00	600	PCS CDMA	RC3 / SO55	25.5	25.44	-0.01	Right	Tilt	04914	1:1	0.032	1.014	0.032	
1880.00	600	PCS CDMA	RC3 / SO55	25.5	25.44	-0.13	Left	Cheek	04914	1:1	0.077	1.014	0.078	A6
1880.00	600	PCS CDMA	RC3 / SO55	25.5	25.44	0.11	Left	Tilt	04914	1:1	0.052	1.014	0.053	
1880.00	600	PCS CDMA	EVDO Rev. A	25.5	24.84	0.20	Right	Cheek	04914	1:1	0.075	1.164	0.087	
1880.00	600	PCS CDMA	EVDO Rev. A	25.5	24.84	0.12	Right	Tilt	04914	1:1	0.033	1.164	0.038	
1880.00	600	PCS CDMA	EVDO Rev. A	25.5	24.84	0.12	Left	Cheek	04914	1:1	0.074	1.164	0.086	
1880.00	600	PCS CDMA	EVDO Rev. A	25.5	24.84	0.13	Left	Tilt	04914	1:1	0.046	1.164	0.054	
ANSI / IEEE C95.1 1992 - SAFETY LIMIT Spatial Peak Uncontrolled Exposure/General Population								Head 1.6 W/kg (mW/g) averaged over 1 gram						

**Table 11-7
LTE Band 12 Head SAR**

MEASUREMENT RESULTS																				
FREQUENCY		Mode	Bandwidth [MHz]	Antenna State	Maximum Allowed Power [dBm]	Conducted Power [dBm]	Power Drift [dB]	MPR [dB]	Side	Test Position	Modulation	RB Size	RB Offset	Device Serial Number	Duty Cycle	SAR (1g)	Scaling Factor	Reported SAR (1g)	Plot #	
MHz	Ch.															(W/kg)		(W/kg)		
707.50	23095	Mid	LTE Band 12	10	13	25.5	25.13	0.13	0	Right	Cheek	QPSK	1	25	04922	1:1	0.106	1.089	0.115	
707.50	23095	Mid	LTE Band 12	10	13	24.5	24.16	0.11	1	Right	Cheek	QPSK	25	12	04922	1:1	0.080	1.081	0.086	
707.50	23095	Mid	LTE Band 12	10	13	25.5	25.13	0.12	0	Right	Tilt	QPSK	1	25	04922	1:1	0.053	1.089	0.058	
707.50	23095	Mid	LTE Band 12	10	13	24.5	24.16	0.13	1	Right	Tilt	QPSK	25	12	04922	1:1	0.043	1.081	0.046	
707.50	23095	Mid	LTE Band 12	10	13	25.5	25.13	0.14	0	Left	Cheek	QPSK	1	25	04922	1:1	0.108	1.089	0.118	A7
707.50	23095	Mid	LTE Band 12	10	13	24.5	24.16	0.06	1	Left	Cheek	QPSK	25	12	04922	1:1	0.088	1.081	0.095	
707.50	23095	Mid	LTE Band 12	10	13	25.5	25.13	0.05	0	Left	Tilt	QPSK	1	25	04922	1:1	0.047	1.089	0.051	
707.50	23095	Mid	LTE Band 12	10	13	24.5	24.16	0.11	1	Left	Tilt	QPSK	25	12	04922	1:1	0.035	1.081	0.038	
ANSI / IEEE C95.1 1992 - SAFETY LIMIT Spatial Peak Uncontrolled Exposure/General Population										Head 1.6 W/kg (mW/g) averaged over 1 gram										

**Table 11-8
LTE Band 13 Head SAR**

MEASUREMENT RESULTS																				
FREQUENCY		Mode	Bandwidth [MHz]	Antenna State	Maximum Allowed Power [dBm]	Conducted Power [dBm]	Power Drift [dB]	MPR [dB]	Side	Test Position	Modulation	RB Size	RB Offset	Device Serial Number	Duty Cycle	SAR (1g)	Scaling Factor	Reported SAR (1g)	Plot #	
MHz	Ch.															(W/kg)		(W/kg)		
782.00	23230	Mid	LTE Band 13	10	4	25.5	24.94	-0.02	0	Right	Cheek	QPSK	1	25	04922	1:1	0.150	1.138	0.171	
782.00	23230	Mid	LTE Band 13	10	4	24.5	24.21	0.06	1	Right	Cheek	QPSK	25	25	04922	1:1	0.123	1.069	0.131	
782.00	23230	Mid	LTE Band 13	10	4	25.5	24.94	0.14	0	Right	Tilt	QPSK	1	25	04922	1:1	0.081	1.138	0.092	
782.00	23230	Mid	LTE Band 13	10	4	24.5	24.21	0.13	1	Right	Tilt	QPSK	25	25	04922	1:1	0.061	1.069	0.065	
782.00	23230	Mid	LTE Band 13	10	4	25.5	24.94	0.05	0	Left	Cheek	QPSK	1	25	04922	1:1	0.161	1.138	0.183	A8
782.00	23230	Mid	LTE Band 13	10	4	24.5	24.21	0.07	1	Left	Cheek	QPSK	25	25	04922	1:1	0.129	1.069	0.138	
782.00	23230	Mid	LTE Band 13	10	4	25.5	24.94	0.00	0	Left	Tilt	QPSK	1	25	04922	1:1	0.061	1.138	0.069	
782.00	23230	Mid	LTE Band 13	10	4	24.5	24.21	0.14	1	Left	Tilt	QPSK	25	25	04922	1:1	0.051	1.069	0.055	
ANSI / IEEE C95.1 1992 - SAFETY LIMIT Spatial Peak Uncontrolled Exposure/General Population										Head 1.6 W/kg (mW/g) averaged over 1 gram										

FCC ID: ZNFG900VM	 PCTEST Proud to be part of 	SAR EVALUATION REPORT		Approved by: Quality Manager
Document S/N: 1M2006040088-01-R1.ZNF	Test Dates: 06/25/20 – 08/05/20	DUT Type: Portable Handset	Page 98 of 159	

**Table 11-9
LTE Band 5 (Cell) Head SAR**



MEASUREMENT RESULTS																						
1 CC Uplink / 2 CC Uplink	Component Carrier	FREQUENCY		Mode	Bandwidth [MHz]	Antenna State	Maximum Allowed Power [dBm]	Conducted Power [dBm]	Power Drift [dB]	MPR [dB]	Side	Test Position	Modulation	RB Size	RB Offset	Device Serial Number	Duty Cycle	SAR (1g)	Scaling Factor	Reported SAR (1g)	Plot #	
		MHz	Ch.															(W/kg)		(W/kg)		
1 CC Uplink	N/A	836.50	20525	Mid	LTE Band 5 (Cell)	10	8	25.5	25.30	0.14	0	Right	Cheek	QPSK	1	0	04922	1:1	0.151	1.047	0.158	
1 CC Uplink	N/A	836.50	20525	Mid	LTE Band 5 (Cell)	10	8	24.5	24.22	-0.02	1	Right	Cheek	QPSK	25	25	04922	1:1	0.120	1.067	0.128	
1 CC Uplink	N/A	836.50	20525	Mid	LTE Band 5 (Cell)	10	8	25.5	25.30	0.12	0	Right	Tilt	QPSK	1	0	04922	1:1	0.092	1.047	0.096	
1 CC Uplink	N/A	836.50	20525	Mid	LTE Band 5 (Cell)	10	8	24.5	24.22	0.07	1	Right	Tilt	QPSK	25	25	04922	1:1	0.065	1.067	0.069	
1 CC Uplink	N/A	836.50	20525	Mid	LTE Band 5 (Cell)	10	8	25.5	25.30	0.02	0	Left	Cheek	QPSK	1	0	04922	1:1	0.188	1.047	0.197	
1 CC Uplink	N/A	836.50	20525	Mid	LTE Band 5 (Cell)	10	8	24.5	24.22	0.12	1	Left	Cheek	QPSK	25	25	04922	1:1	0.148	1.067	0.158	
2 CC Uplink	PCC	836.50	20525	Mid	LTE Band 5 (Cell)	10	8	25.5	25.50	0.03	0	Left	Cheek	QPSK	1	0	04922	1:1	0.196	1.000	0.196	A9
	SCC	829.30	20453	Mid	LTE Band 5 (Cell)	5	8								1	24						
1 CC Uplink	N/A	836.50	20525	Mid	LTE Band 5 (Cell)	10	8	25.5	25.30	0.13	0	Left	Tilt	QPSK	1	0	04922	1:1	0.071	1.047	0.074	
1 CC Uplink	N/A	836.50	20525	Mid	LTE Band 5 (Cell)	10	8	24.5	24.22	0.12	1	Left	Tilt	QPSK	25	25	04922	1:1	0.057	1.067	0.061	
ANSI / IEEE C95.1 1992 - SAFETY LIMIT Spatial Peak												Head 1.6 W/kg (mW/g) averaged over 1 gram										
Uncontrolled Exposure/General Population																						

**Table 11-10
LTE Band 66 (AWS) Head SAR**

MEASUREMENT RESULTS																				
FREQUENCY	Mode	Bandwidth [MHz]	Maximum Allowed Power [dBm]	Conducted Power [dBm]	Power Drift [dB]	MPR [dB]	Side	Test Position	Modulation	RB Size	RB Offset	Device Serial Number	Duty Cycle	SAR (1g)	Scaling Factor	Reported SAR (1g)	Plot #			
														MHz		Ch.		(W/kg)	(W/kg)	
1770.00	132572	High	LTE Band 66 (AWS)	20	25.5	25.32	-0.03	0	Right	Cheek	QPSK	1	0	04922	1:1	0.087	1.042	0.091	A10	
1770.00	132572	High	LTE Band 66 (AWS)	20	24.5	24.26	0.10	1	Right	Cheek	QPSK	50	25	04922	1:1	0.076	1.057	0.080		
1770.00	132572	High	LTE Band 66 (AWS)	20	25.5	25.32	0.14	0	Right	Tilt	QPSK	1	0	04922	1:1	0.032	1.042	0.033		
1770.00	132572	High	LTE Band 66 (AWS)	20	24.5	24.26	0.14	1	Right	Tilt	QPSK	50	25	04922	1:1	0.024	1.057	0.025		
1770.00	132572	High	LTE Band 66 (AWS)	20	25.5	25.32	0.19	0	Left	Cheek	QPSK	1	0	04922	1:1	0.053	1.042	0.055		
1770.00	132572	High	LTE Band 66 (AWS)	20	24.5	24.26	0.13	1	Left	Cheek	QPSK	50	25	04922	1:1	0.045	1.057	0.048		
1770.00	132572	High	LTE Band 66 (AWS)	20	25.5	25.32	0.13	0	Left	Tilt	QPSK	1	0	04922	1:1	0.040	1.042	0.042		
1770.00	132572	High	LTE Band 66 (AWS)	20	24.5	24.26	0.13	1	Left	Tilt	QPSK	50	25	04922	1:1	0.037	1.057	0.039		
ANSI / IEEE C95.1 1992 - SAFETY LIMIT Spatial Peak												Head 1.6 W/kg (mW/g) averaged over 1 gram								
Uncontrolled Exposure/General Population																				

**Table 11-11
LTE Band 2 (PCS) Head SAR**

MEASUREMENT RESULTS																				
FREQUENCY	Mode	Bandwidth [MHz]	Maximum Allowed Power [dBm]	Conducted Power [dBm]	Power Drift [dB]	MPR [dB]	Side	Test Position	Modulation	RB Size	RB Offset	Device Serial Number	Duty Cycle	SAR (1g)	Scaling Factor	Reported SAR (1g)	Plot #			
														MHz		Ch.		(W/kg)	(W/kg)	
1880.00	18900	Mid	LTE Band 2 (PCS)	20	25.5	25.19	0.13	0	Right	Cheek	QPSK	1	99	04922	1:1	0.122	1.074	0.131	A11	
1880.00	18900	Mid	LTE Band 2 (PCS)	20	24.5	24.19	0.15	1	Right	Cheek	QPSK	50	50	04922	1:1	0.088	1.074	0.095		
1880.00	18900	Mid	LTE Band 2 (PCS)	20	25.5	25.19	0.17	0	Right	Tilt	QPSK	1	99	04922	1:1	0.040	1.074	0.043		
1880.00	18900	Mid	LTE Band 2 (PCS)	20	24.5	24.19	0.17	1	Right	Tilt	QPSK	50	50	04922	1:1	0.028	1.074	0.030		
1880.00	18900	Mid	LTE Band 2 (PCS)	20	25.5	25.19	-0.04	0	Left	Cheek	QPSK	1	99	04922	1:1	0.094	1.074	0.101		
1880.00	18900	Mid	LTE Band 2 (PCS)	20	24.5	24.19	0.04	1	Left	Cheek	QPSK	50	50	04922	1:1	0.087	1.074	0.093		
1880.00	18900	Mid	LTE Band 2 (PCS)	20	25.5	25.19	-0.02	0	Left	Tilt	QPSK	1	99	04922	1:1	0.066	1.074	0.071		
1880.00	18900	Mid	LTE Band 2 (PCS)	20	24.5	24.19	0.13	1	Left	Tilt	QPSK	50	50	04922	1:1	0.055	1.074	0.059		
ANSI / IEEE C95.1 1992 - SAFETY LIMIT Spatial Peak												Head 1.6 W/kg (mW/g) averaged over 1 gram								
Uncontrolled Exposure/General Population																				

FCC ID: ZNFG900VM		SAR EVALUATION REPORT		Approved by: Quality Manager
Document S/N: 1M2006040088-01-R1.ZNF	Test Dates: 06/25/20 – 08/05/20	DUT Type: Portable Handset		Page 99 of 159

**Table 11-12
LTE Band 48 Head SAR**

MEASUREMENT RESULTS																				
FREQUENCY		Mode	Bandwidth [MHz]	Dual Display Accessory Configuration	Maximum Allowed Power [dBm]	Conducted Power [dBm]	Power Drift [dB]	MPR [dB]	Side	Test Position	Modulation	RB Size	RB Offset	Device Serial Number	Duty Cycle	SAR (1g)	Scaling Factor	Reported SAR (1g)	Plot #	
MHz	Ch.															(W/kg)		(W/kg)		
3560.00	55340	Low	LTE Band 48	20	-	23.5	23.01	0.14	0	Right	Cheek	QPSK	1	50	01738	1:1.58	0.066	1.119	0.074	
3560.00	55340	Low	LTE Band 48	20	-	23.5	23.10	0.15	0	Right	Cheek	QPSK	50	25	01738	1:1.58	0.065	1.096	0.071	
3560.00	55340	Low	LTE Band 48	20	-	23.5	23.01	-0.16	0	Right	Tilt	QPSK	1	50	01738	1:1.58	0.032	1.119	0.036	
3560.00	55340	Low	LTE Band 48	20	-	23.5	23.10	0.08	0	Right	Tilt	QPSK	50	25	01738	1:1.58	0.026	1.096	0.028	
3560.00	55340	Low	LTE Band 48	20	-	23.5	23.01	-0.03	0	Left	Cheek	QPSK	1	50	01738	1:1.58	0.096	1.119	0.107	
3560.00	55340	Low	LTE Band 48	20	-	23.5	23.10	-0.09	0	Left	Cheek	QPSK	50	25	01738	1:1.58	0.089	1.096	0.098	
3560.00	55340	Low	LTE Band 48	20	-	23.5	23.01	0.13	0	Left	Tilt	QPSK	1	50	01738	1:1.58	0.053	1.119	0.059	
3560.00	55340	Low	LTE Band 48	20	-	23.5	23.10	0.13	0	Left	Tilt	QPSK	50	25	01738	1:1.58	0.050	1.096	0.055	
3560.00	55340	Low	LTE Band 48	20	#3	24.5	24.00	0.21	0	Right	Cheek	QPSK	1	0	04948	1:1.58	0.111	1.122	0.125	
3560.00	55340	Low	LTE Band 48	20	#3	24.5	24.00	0.07	0	Right	Tilt	QPSK	1	0	04948	1:1.58	0.129	1.122	0.145	
3560.00	55340	Low	LTE Band 48	20	#3	24.5	24.00	0.00	0	Left	Cheek	QPSK	1	0	04948	1:1.58	0.176	1.122	0.197	
3560.00	55340	Low	LTE Band 48	20	#3	24.5	24.00	0.06	0	Left	Tilt	QPSK	1	0	04948	1:1.58	0.237	1.122	0.266	A12
ANSI / IEEE C95.1 1992 - SAFETY LIMIT Spatial Peak Uncontrolled Exposure/General Population										Head 1.6 W/kg (mW/g) averaged over 1 gram										

Note: 1) Light orange entries represent additional Head SAR Position (DD #3: 360 degrees)



**Table 11-13
NR Band n5 (Cell) Head SAR**

MEASUREMENT RESULTS																				
FREQUENCY		Mode	Bandwidth [MHz]	Antenna Config	Maximum Allowed Power [dBm]	Conducted Power [dBm]	Power Drift [dB]	MPR [dB]	Side	Test Position	Modulation	RB Size	RB Offset	Device Serial Number	Duty Cycle	SAR (1g)	Scaling Factor	Reported SAR (1g)	Plot #	
MHz	Ch.															(W/kg)		(W/kg)		
836.50	167300	Mid	NR Band n5 (Cell)	20	8	24.8	24.60	-0.19	0	Right	Cheek	DFT-S-OFDM QPSK	1	53	01217	1:1	0.103	1.047	0.108	
836.50	167300	Mid	NR Band n5 (Cell)	20	8	24.8	24.43	0.12	0	Right	Cheek	DFT-S-OFDM QPSK	50	28	01217	1:1	0.108	1.089	0.118	
836.50	167300	Mid	NR Band n5 (Cell)	20	8	24.8	24.60	0.12	0	Right	Tilt	DFT-S-OFDM QPSK	1	53	01217	1:1	0.056	1.047	0.059	
836.50	167300	Mid	NR Band n5 (Cell)	20	8	24.8	24.43	0.12	0	Right	Tilt	DFT-S-OFDM QPSK	50	28	01217	1:1	0.059	1.089	0.064	
836.50	167300	Mid	NR Band n5 (Cell)	20	8	24.8	24.60	0.15	0	Left	Cheek	DFT-S-OFDM QPSK	1	53	01217	1:1	0.127	1.047	0.133	
836.50	167300	Mid	NR Band n5 (Cell)	20	8	24.8	24.43	0.08	0	Left	Cheek	DFT-S-OFDM QPSK	50	28	01217	1:1	0.130	1.089	0.142	A13
836.50	167300	Mid	NR Band n5 (Cell)	20	8	23.3	22.59	0.14	1.5	Left	Cheek	CP-OFDM QPSK	1	1	01217	1:1	0.076	1.178	0.090	
836.50	167300	Mid	NR Band n5 (Cell)	20	8	24.8	24.60	0.11	0	Left	Tilt	DFT-S-OFDM QPSK	1	53	01217	1:1	0.046	1.047	0.048	
836.50	167300	Mid	NR Band n5 (Cell)	20	8	24.8	24.43	0.13	0	Left	Tilt	DFT-S-OFDM QPSK	50	28	01217	1:1	0.050	1.089	0.054	
ANSI / IEEE C95.1 1992 - SAFETY LIMIT Spatial Peak Uncontrolled Exposure/General Population										Head 1.6 W/kg (mW/g) averaged over 1 gram										

**Table 11-14
NR Band n66 (AWS) Head SAR**

MEASUREMENT RESULTS																				
FREQUENCY		Mode	Bandwidth [MHz]	Dual Display Accessory Configuration	Maximum Allowed Power [dBm]	Conducted Power [dBm]	Power Drift [dB]	MPR [dB]	Side	Test Position	Modulation	RB Size	RB Offset	Device Serial Number	Duty Cycle	SAR (1g)	Scaling Factor	Reported SAR (1g)	Plot #	
MHz	Ch.															(W/kg)		(W/kg)		
1720.00	344000	Low	NR Band n66 (AWS)	20	-	24.5	23.76	0.15	0	Right	Cheek	DFT-S-OFDM QPSK	1	104	01217	1:1	0.106	1.186	0.126	
1770.00	354000	High	NR Band n66 (AWS)	20	#3	25.5	25.02	-0.04	0	Right	Cheek	DFT-S-OFDM QPSK	1	104	01217	1:1	0.177	1.117	0.198	A14
1720.00	344000	Low	NR Band n66 (AWS)	20	-	24.5	23.75	0.01	0	Right	Cheek	DFT-S-OFDM QPSK	50	28	01217	1:1	0.114	1.189	0.136	
1745.00	349000	Mid	NR Band n66 (AWS)	20	-	24.0	23.15	0.03	0.5	Right	Cheek	CP-OFDM QPSK	1	1	01217	1:1	0.097	1.216	0.118	
1720.00	344000	Low	NR Band n66 (AWS)	20	-	24.5	23.76	0.16	0	Right	Tilt	DFT-S-OFDM QPSK	1	104	01217	1:1	0.042	1.186	0.037	
1770.00	354000	High	NR Band n66 (AWS)	20	#3	25.5	25.02	-0.07	0	Right	Tilt	DFT-S-OFDM QPSK	1	104	01217	1:1	0.056	1.117	0.063	
1720.00	344000	Low	NR Band n66 (AWS)	20	-	24.5	23.75	0.12	0	Right	Tilt	DFT-S-OFDM QPSK	50	28	01217	1:1	0.050	1.189	0.059	
1720.00	344000	Low	NR Band n66 (AWS)	20	-	24.5	23.76	0.04	0	Left	Cheek	DFT-S-OFDM QPSK	1	104	01217	1:1	0.051	1.186	0.060	
1770.00	354000	High	NR Band n66 (AWS)	20	#3	25.5	25.02	0.10	0	Left	Cheek	DFT-S-OFDM QPSK	1	104	01217	1:1	0.101	1.117	0.113	
1720.00	344000	Low	NR Band n66 (AWS)	20	-	24.5	23.75	0.05	0	Left	Cheek	DFT-S-OFDM QPSK	50	28	01217	1:1	0.056	1.189	0.067	
1720.00	344000	Low	NR Band n66 (AWS)	20	-	24.5	23.76	0.16	0	Left	Tilt	DFT-S-OFDM QPSK	1	104	01217	1:1	0.033	1.186	0.039	
1770.00	354000	High	NR Band n66 (AWS)	20	#3	25.5	25.02	-0.06	0	Left	Tilt	DFT-S-OFDM QPSK	1	104	01217	1:1	0.085	1.117	0.095	
1720.00	344000	Low	NR Band n66 (AWS)	20	-	24.5	23.75	0.13	0	Left	Tilt	DFT-S-OFDM QPSK	50	28	01217	1:1	0.032	1.189	0.038	
ANSI / IEEE C95.1 1992 - SAFETY LIMIT Spatial Peak Uncontrolled Exposure/General Population										Head 1.6 W/kg (mW/g) averaged over 1 gram										

Note: 1) Light orange entries represent additional Head SAR Position (DD #3: 360 degrees)

FCC ID: ZNFG900VM		SAR EVALUATION REPORT		Approved by: Quality Manager
Document S/N: 1M2006040088-01-R1.ZNF	Test Dates: 06/25/20 – 08/05/20	DUT Type: Portable Handset		Page 100 of 159

**Table 11-15
NR Band n2 (PCS) Head SAR**



MEASUREMENT RESULTS																				
FREQUENCY		Mode	Bandwidth [MHz]	Dual Display Accessory Configuration	Maximum Allowed Power [dBm]	Conducted Power [dBm]	Power Drift [dB]	MPR [dB]	Side	Test Position	Modulation	RB Size	RB Offset	Device Serial Number	Duty Cycle	SAR (1g)	Scaling Factor	Reported SAR (1g)	Plot #	
MHz	Ch.															(W/kg)		(W/kg)		
1860.00	372000	Low	NR Band n2 (PCS)	20	-	24.5	23.72	0.18	0	Right	Cheek	DFT-S-OFDM QPSK	1	1	05002	1:1	0.130	1.197	0.156	
1860.00	372000	Low	NR Band n2 (PCS)	20	#3	25.5	24.64	0.15	0	Right	Cheek	DFT-S-OFDM QPSK	1	1	05002	1:1	0.132	1.219	0.161	
1860.00	372000	Low	NR Band n2 (PCS)	20	-	24.5	23.62	0.11	0	Right	Cheek	DFT-S-OFDM QPSK	50	28	05002	1:1	0.139	1.225	0.170	A15
1860.00	372000	Low	NR Band n2 (PCS)	20	-	24.0	22.84	0.05	0.5	Right	Cheek	CP-OFDM QPSK	1	1	05002	1:1	0.109	1.306	0.142	
1860.00	372000	Low	NR Band n2 (PCS)	20	-	24.5	23.72	0.13	0	Right	Tilt	DFT-S-OFDM QPSK	1	1	05002	1:1	0.039	1.197	0.047	
1860.00	372000	Low	NR Band n2 (PCS)	20	#3	25.5	24.64	-0.15	0	Right	Tilt	DFT-S-OFDM QPSK	1	1	05002	1:1	0.029	1.219	0.035	
1860.00	372000	Low	NR Band n2 (PCS)	20	-	24.5	23.62	0.14	0	Right	Tilt	DFT-S-OFDM QPSK	50	28	05002	1:1	0.041	1.225	0.050	
1860.00	372000	Low	NR Band n2 (PCS)	20	-	24.5	23.72	-0.06	0	Left	Cheek	DFT-S-OFDM QPSK	1	1	05002	1:1	0.074	1.197	0.089	
1860.00	372000	Low	NR Band n2 (PCS)	20	#3	25.5	24.64	0.12	0	Left	Cheek	DFT-S-OFDM QPSK	1	1	05002	1:1	0.076	1.219	0.093	
1860.00	372000	Low	NR Band n2 (PCS)	20	-	24.5	23.62	0.17	0	Left	Cheek	DFT-S-OFDM QPSK	50	28	05002	1:1	0.074	1.225	0.091	
1860.00	372000	Low	NR Band n2 (PCS)	20	-	24.5	23.72	0.21	0	Left	Tilt	DFT-S-OFDM QPSK	1	1	05002	1:1	0.046	1.197	0.055	
1860.00	372000	Low	NR Band n2 (PCS)	20	#3	25.5	24.64	0.13	0	Left	Tilt	DFT-S-OFDM QPSK	1	1	05002	1:1	0.032	1.219	0.039	
1860.00	372000	Low	NR Band n2 (PCS)	20	-	24.5	23.62	0.16	0	Left	Tilt	DFT-S-OFDM QPSK	50	28	05002	1:1	0.042	1.225	0.051	
ANSI / IEEE C95.1 1992 - SAFETY LIMIT												Head								
Spatial Peak												1.6 W/kg (mW/g)								
Uncontrolled Exposure/General Population												averaged over 1 gram								

Note: 1) Light orange entries represent additional Head SAR Position (DD #3: 360 degrees)

**Table 11-16
DTS Head SAR**

MEASUREMENT RESULTS																				
FREQUENCY		Mode	Service	Bandwidth [MHz]	Maximum Allowed Power [dBm]	Conducted Power [dBm]	Power Drift [dB]	Side	Test Position	Antenna Config	Dual Display Accessory Configuration	Device Serial Number	Data Rate (Mbps)	Duty Cycle (%)	Peak SAR of Area Scan W/kg	SAR (1g)	Scaling Factor (Power)	Scaling Factor (Duty Cycle)	Reported SAR (1g)	Plot #
MHz	Ch.															(W/kg)			(W/kg)	
2437	6	802.11b	DSSS	22	15.0	14.51	-0.17	Right	Cheek	1	-	04732	1	99.3	0.489	0.274	1.119	1.007	0.309	
2437	6	802.11b	DSSS	22	15.0	14.51	0.07	Right	Tilt	1	-	04732	1	99.3	0.275	-	1.119	1.007	-	
2437	6	802.11b	DSSS	22	15.0	14.51	-0.18	Left	Cheek	1	-	04732	1	99.3	0.105	-	1.119	1.007	-	
2437	6	802.11b	DSSS	22	15.0	14.51	-0.16	Left	Tilt	1	-	04732	1	99.3	0.112	-	1.119	1.007	-	
2412	1	802.11b	DSSS	22	15.0	14.73	-0.18	Right	Cheek	2	-	04732	1	99.3	0.532	0.328	1.222	1.007	0.404	
2437	6	802.11b	DSSS	22	15.0	14.66	-0.16	Right	Cheek	2	-	04732	1	99.3	0.911	0.560	1.081	1.007	0.610	A16
2437	6	802.11b	DSSS	22	15.0	14.66	-0.02	Right	Cheek	2	#1	04740	1	99.3	0.204	0.120	1.081	1.007	0.131	
2437	6	802.11b	DSSS	22	15.0	14.66	0.15	Right	Cheek	2	#3	04740	1	99.3	0.875	0.546	1.081	1.007	0.594	
2462	11	802.11b	DSSS	22	15.0	14.49	0.16	Right	Cheek	2	-	04732	1	99.3	0.833	0.512	1.125	1.007	0.580	
2437	6	802.11b	DSSS	22	15.0	14.66	0.09	Right	Tilt	2	-	04732	1	99.3	0.747	0.538	1.081	1.007	0.586	
2437	6	802.11b	DSSS	22	15.0	14.66	-0.01	Left	Cheek	2	-	04732	1	99.3	0.575	-	1.081	1.007	-	
2437	6	802.11b	DSSS	22	15.0	14.66	-0.12	Left	Tilt	2	-	04732	1	99.3	0.578	-	1.081	1.007	-	
ANSI / IEEE C95.1 1992 - SAFETY LIMIT												Head								
Spatial Peak												1.6 W/kg (mW/g)								
Uncontrolled Exposure/General Population												averaged over 1 gram								

Note: 1) Light green entries represent additional Head SAR Position (DD #: 0 degrees) 2) Light orange entries represent additional Head SAR Position (DD #3: 360 degrees)



FCC ID: ZNFG900VM		SAR EVALUATION REPORT		Approved by: Quality Manager
Document S/N: 1M2006040088-01-R1.ZNF	Test Dates: 06/25/20 – 08/05/20	DUT Type: Portable Handset	Page 101 of 159	

**Table 11-17
NII Head SAR**

MEASUREMENT RESULTS																			
FREQUENCY		Mode	Service	Bandwidth [MHz]	Maximum Allowed Power [dBm]	Conducted Power [dBm]	Power Drift [dB]	Side	Test Position	Antenna Config.	Device Serial Number	Data Rate (Mbps)	Duty Cycle (%)	Peak SAR of Area Scan	SAR (1g)	Scaling Factor (Power)	Scaling Factor (Duty Cycle)	Reported SAR (1g)	Plot #
MHz	Ch.													W/kg	(W/kg)			(W/kg)	
5270	54	802.11n	OFDM	40	16.0	15.54	0.13	Right	Cheek	1	04732	13.5	97.4	0.392	0.189	1.112	1.027	0.216	
5270	54	802.11n	OFDM	40	16.0	15.54	0.14	Right	Tilt	1	04732	13.5	97.4	0.309	-	1.112	1.027	-	
5270	54	802.11n	OFDM	40	16.0	15.54	0.15	Left	Cheek	1	04732	13.5	97.4	0.255	-	1.112	1.027	-	
5270	54	802.11n	OFDM	40	16.0	15.54	0.12	Left	Tilt	1	04732	13.5	97.4	0.258	-	1.112	1.027	-	
5310	62	802.11n	OFDM	40	16.0	15.59	0.17	Right	Cheek	2	04732	13.5	97.3	0.308	-	1.099	1.028	-	
5310	62	802.11n	OFDM	40	16.0	15.59	0.11	Right	Tilt	2	04732	13.5	97.3	0.312	0.112	1.099	1.028	0.127	
5310	62	802.11n	OFDM	40	16.0	15.59	0.08	Left	Cheek	2	04732	13.5	97.3	0.309	-	1.099	1.028	-	
5310	62	802.11n	OFDM	40	16.0	15.59	0.13	Left	Tilt	2	04732	13.5	97.3	0.261	-	1.099	1.028	-	
5710	142	802.11n	OFDM	40	16.0	15.92	0.12	Right	Cheek	1	04732	13.5	97.4	0.026	-	1.019	1.027	-	
5710	142	802.11n	OFDM	40	16.0	15.92	0.16	Right	Tilt	1	04732	13.5	97.4	0.033	-	1.019	1.027	-	
5710	142	802.11n	OFDM	40	16.0	15.92	-0.14	Left	Cheek	1	04732	13.5	97.4	0.036	-	1.019	1.027	-	
5710	142	802.11n	OFDM	40	16.0	15.92	-0.06	Left	Tilt	1	04732	13.5	97.4	0.044	0.017	1.019	1.027	0.018	
5510	102	802.11n	OFDM	40	16.0	15.78	0.15	Right	Cheek	2	04732	13.5	97.3	0.402	0.239	1.052	1.028	0.258	A17
5510	102	802.11n	OFDM	40	16.0	15.78	0.12	Right	Tilt	2	04732	13.5	97.3	0.319	-	1.052	1.028	-	
5510	102	802.11n	OFDM	40	16.0	15.78	0.14	Left	Cheek	2	04732	13.5	97.3	0.187	-	1.052	1.028	-	
5510	102	802.11n	OFDM	40	16.0	15.78	-0.18	Left	Tilt	2	04732	13.5	97.3	0.162	-	1.052	1.028	-	
5795	159	802.11n	OFDM	40	16.0	15.93	0.15	Right	Cheek	1	04732	13.5	97.4	0.021	-	1.016	1.027	-	
5795	159	802.11n	OFDM	40	16.0	15.93	0.12	Right	Tilt	1	04732	13.5	97.4	0.023	-	1.016	1.027	-	
5795	159	802.11n	OFDM	40	16.0	15.93	0.14	Left	Cheek	1	04732	13.5	97.4	0.039	-	1.016	1.027	-	
5795	159	802.11n	OFDM	40	16.0	15.93	0.13	Left	Tilt	1	04732	13.5	97.4	0.046	0.017	1.016	1.027	0.018	
5795	159	802.11n	OFDM	40	16.0	15.66	0.11	Right	Cheek	2	04732	13.5	97.3	0.277	0.124	1.081	1.028	0.138	
5795	159	802.11n	OFDM	40	16.0	15.66	0.17	Right	Tilt	2	04732	13.5	97.3	0.228	-	1.081	1.028	-	
5795	159	802.11n	OFDM	40	16.0	15.66	-0.12	Left	Cheek	2	04732	13.5	97.3	0.164	-	1.081	1.028	-	
5795	159	802.11n	OFDM	40	16.0	15.66	0.17	Left	Tilt	2	04732	13.5	97.3	0.152	-	1.081	1.028	-	
ANSI / IEEE C95.1 1992 - SAFETY LIMIT Spatial Peak Uncontrolled Exposure/General Population											Head 1.6 W/kg (mW/g) averaged over 1 gram								

**Table 11-18
DSS Head SAR**

MEASUREMENT RESULTS																
FREQUENCY		Mode	Service	Maximum Allowed Power [dBm]	Conducted Power [dBm]	Power Drift [dB]	Side	Test Position	Device Serial Number	Data Rate (Mbps)	Duty Cycle (%)	SAR (1g)	Scaling Factor (Cond Power)	Scaling Factor (Duty Cycle)	Reported SAR (1g)	Plot #
MHz	Ch.											(W/kg)			(W/kg)	
2441.00	39	Bluetooth	FHSS	11.5	11.36	-0.04	Right	Cheek	04740	1	77.3	0.056	1.033	1.294	0.075	A18
2441.00	39	Bluetooth	FHSS	11.5	11.36	0.14	Right	Tilt	04740	1	77.3	0.043	1.033	1.294	0.057	
2441.00	39	Bluetooth	FHSS	11.5	11.36	0.04	Left	Cheek	04740	1	77.3	0.017	1.033	1.294	0.023	
2441.00	39	Bluetooth	FHSS	11.5	11.36	0.13	Left	Tilt	04740	1	77.3	0.024	1.033	1.294	0.032	
ANSI / IEEE C95.1 1992 - SAFETY LIMIT Spatial Peak Uncontrolled Exposure/General Population											Head 1.6 W/kg (mW/g) averaged over 1 gram					



FCC ID: ZNFG900VM		SAR EVALUATION REPORT		Approved by: Quality Manager
Document S/N: 1M2006040088-01-R1.ZNF	Test Dates: 06/25/20 – 08/05/20	DUT Type: Portable Handset	Page 102 of 159	

11.2 Standalone Body-Worn SAR Data

**Table 11-19
GSM/UMTS/CDMA Body-Worn SAR Data**

MEASUREMENT RESULTS																
FREQUENCY		Mode	Service	Maximum Allowed Power [dBm]	Conducted Power [dBm]	Power Drift [dB]	Spacing	Antenna State	Device Serial Number	# of Time Slots	Duty Cycle	Side	SAR (1g) (W/kg)	Scaling Factor	Reported SAR (1g) (W/kg)	Plot #
MHz	Ch.															
836.60	190	GSM 850	GSM	33.5	33.12	-0.04	10 mm	N/A	04948	1	1:8.3	back	0.447	1.091	0.488	
824.20	128	GSM 850	GPRS	32.0	31.46	-0.15	10 mm	N/A	04948	2	1:4.15	back	0.622	1.132	0.704	
836.60	190	GSM 850	GPRS	32.0	31.43	0.14	10 mm	N/A	04948	2	1:4.15	back	0.665	1.140	0.758	A19
848.80	251	GSM 850	GPRS	32.0	31.37	0.21	10 mm	N/A	04948	2	1:4.15	back	0.662	1.156	0.765	
1880.00	661	GSM 1900	GSM	30.5	29.84	0.03	10 mm	N/A	04922	1	1:8.3	back	0.342	1.164	0.398	
1880.00	661	GSM 1900	GPRS	29.0	28.99	0.02	10 mm	N/A	04922	2	1:4.15	back	0.450	1.002	0.451	A20
826.40	4132	UMTS 850	RMC	25.5	25.29	-0.02	10 mm	8	04955	N/A	1:1	back	0.657	1.050	0.690	
836.60	4183	UMTS 850	RMC	25.5	25.28	-0.03	10 mm	8	04955	N/A	1:1	back	0.707	1.052	0.744	A22
846.60	4233	UMTS 850	RMC	25.5	25.24	-0.02	10 mm	8	04955	N/A	1:1	back	0.687	1.062	0.730	
1852.40	9262	UMTS 1900	RMC	25.5	25.19	0.06	10 mm	N/A	04914	N/A	1:1	back	1.000	1.074	1.074	
1880.00	9400	UMTS 1900	RMC	25.5	25.25	0.01	10 mm	N/A	04914	N/A	1:1	back	1.070	1.059	1.133	A23
1907.60	9538	UMTS 1900	RMC	25.5	25.23	0.09	10 mm	N/A	04914	N/A	1:1	back	1.050	1.064	1.117	
1880.00	9400	UMTS 1900	RMC	25.5	25.25	0.15	10 mm	N/A	04914	N/A	1:1	back	1.010	1.059	1.070	
824.70	1013	Cell. CDMA	TDSO / SO32	25.5	25.38	-0.03	10 mm	8	04955	N/A	1:1	back	0.687	1.028	0.706	
836.52	384	Cell. CDMA	TDSO / SO32	25.5	25.44	-0.03	10 mm	8	04955	N/A	1:1	back	0.730	1.014	0.740	A25
848.31	777	Cell. CDMA	TDSO / SO32	25.5	25.41	0.07	10 mm	8	04955	N/A	1:1	back	0.665	1.021	0.679	
1851.25	25	PCS CDMA	TDSO / SO32	25.5	25.42	0.13	10 mm	N/A	04922	N/A	1:1	back	0.916	1.019	0.933	A27
1880.00	600	PCS CDMA	TDSO / SO32	25.5	25.46	0.05	10 mm	N/A	04922	N/A	1:1	back	0.860	1.009	0.868	
1908.75	1175	PCS CDMA	TDSO / SO32	25.5	25.47	0.10	10 mm	N/A	04922	N/A	1:1	back	0.844	1.007	0.850	
ANSI / IEEE C95.1 1992 - SAFETY LIMIT Spatial Peak Uncontrolled Exposure/General Population							Body 1.6 W/kg (mW/g) averaged over 1 gram									

Note: Blue entry represents variability measurements.

FCC ID: ZNFG900VM	 PCTEST Proud to be part of 	SAR EVALUATION REPORT		Approved by: Quality Manager
Document S/N: 1M2006040088-01-R1.ZNF	Test Dates: 06/25/20 – 08/05/20	DUT Type: Portable Handset	Page 103 of 159	



**Table 11-20
LTE Body-Worn SAR**

MEASUREMENT RESULTS																					
FREQUENCY		Mode	Bandwidth [MHz]	Antenna State	Maximum Allowed Power [dBm]	Conducted Power [dBm]	Power Drift [dB]	MPR [dB]	Dual Display Accessory Configuration	Device Serial Number	Modulation	RB Size	RB Offset	Spacing	Side	Duty Cycle	SAR (1g)	Scaling Factor	Reported SAR (1g)	Plot #	
MHz	Ch.																(W/kg)		(W/kg)		
707.50	23095	Mid	LTE Band 12	10	12	25.5	25.13	-0.03	0	-	04922	QPSK	1	25	10 mm	back	1:1	0.298	1.089	0.325	A29
707.50	23095	Mid	LTE Band 12	10	12	24.5	24.16	-0.01	1	-	04922	QPSK	25	12	10 mm	back	1:1	0.243	1.081	0.263	
782.00	23230	Mid	LTE Band 13	10	3	25.5	24.94	0.15	0	-	04922	QPSK	1	25	10 mm	back	1:1	0.541	1.138	0.616	A30
782.00	23230	Mid	LTE Band 13	10	3	24.5	24.21	-0.02	1	-	04922	QPSK	25	25	10 mm	back	1:1	0.447	1.069	0.478	
1720.00	132072	Low	LTE Band 66 (AWS)	20	N/A	25.5	25.10	0.09	0	-	04930	QPSK	1	50	10 mm	back	1:1	0.835	1.096	0.915	
1745.00	132322	Mid	LTE Band 66 (AWS)	20	N/A	25.5	25.02	0.10	0	-	04930	QPSK	1	50	10 mm	back	1:1	0.854	1.117	0.954	A32
1770.00	132572	High	LTE Band 66 (AWS)	20	N/A	25.5	25.32	0.06	0	-	04930	QPSK	1	0	10 mm	back	1:1	0.829	1.042	0.864	
1770.00	132572	High	LTE Band 66 (AWS)	20	N/A	24.5	24.26	0.05	1	-	04930	QPSK	50	25	10 mm	back	1:1	0.709	1.057	0.749	
1770.00	132572	High	LTE Band 66 (AWS)	20	N/A	24.5	24.25	0.07	1	-	04930	QPSK	100	0	10 mm	back	1:1	0.675	1.059	0.715	
1860.00	18700	Low	LTE Band 2 (PCS)	20	N/A	25.5	25.06	0.00	0	-	04914	QPSK	1	99	10 mm	back	1:1	1.010	1.107	1.118	
1880.00	18900	Mid	LTE Band 2 (PCS)	20	N/A	25.5	25.19	0.00	0	-	04914	QPSK	1	99	10 mm	back	1:1	1.030	1.074	1.106	A34
1900.00	19100	High	LTE Band 2 (PCS)	20	N/A	25.5	24.93	-0.01	0	-	04914	QPSK	1	99	10 mm	back	1:1	0.999	1.140	1.139	
1860.00	18700	Low	LTE Band 2 (PCS)	20	N/A	24.5	24.17	0.03	1	-	04914	QPSK	50	25	10 mm	back	1:1	0.837	1.079	0.903	
1880.00	18900	Mid	LTE Band 2 (PCS)	20	N/A	24.5	24.19	0.02	1	-	04914	QPSK	50	50	10 mm	back	1:1	0.871	1.074	0.935	
1900.00	19100	High	LTE Band 2 (PCS)	20	N/A	24.5	24.18	0.01	1	-	04914	QPSK	50	50	10 mm	back	1:1	0.864	1.076	0.930	
1860.00	18700	Low	LTE Band 2 (PCS)	20	N/A	24.5	24.11	0.00	1	-	04914	QPSK	100	0	10 mm	back	1:1	0.834	1.094	0.912	
1860.00	18700	Low	LTE Band 2 (PCS)	20	N/A	25.0	24.99	-0.09	0	#1	04922	QPSK	1	50	10 mm	back	1:1	0.895	1.002	0.896	
1860.00	18700	Low	LTE Band 2 (PCS)	20	N/A	25.0	24.99	0.04	0	#2	04922	QPSK	1	50	10 mm	back	1:1	0.504	1.002	0.505	
1860.00	18700	Low	LTE Band 2 (PCS)	20	N/A	25.0	24.99	0.15	0	#3	04922	QPSK	1	50	10 mm	back	1:1	0.243	1.002	0.243	
3560.00	55340	Low	LTE Band 48	20	N/A	23.5	23.01	0.12	0	-	04948	QPSK	1	50	10 mm	back	1:1.58	0.150	1.119	0.168	
3560.00	55340	Low	LTE Band 48	20	N/A	24.5	24.00	0.13	0	#1	04948	QPSK	1	0	10 mm	back	1:1.58	0.180	1.122	0.202	A36
3560.00	55340	Low	LTE Band 48	20	N/A	23.5	23.10	0.14	0	-	04948	QPSK	50	25	10 mm	back	1:1.58	0.150	1.096	0.164	
ANSI / IEEE C95.1 1992 - SAFETY LIMIT Spatial Peak Uncontrolled Exposure/General Population											Body 1.6 W/kg (mW/g) averaged over 1 gram										

Note: 1) Light Green entries represent additional Body-Worn SAR Position (DD #1: 0 degrees) 2) Light purple entries represent additional Body-Worn SAR Position (DD #2: 180 degrees) 3) Light Orange entries represent additional Body-Worn SAR Position (DD #3: 360 degrees)

**Table 11-21
LTE Band 5 Body-Worn SAR**

MEASUREMENT RESULTS																						
1 CC Uplink / 2 CC Uplink	Component Carrier	FREQUENCY		Mode	Bandwidth [MHz]	Antenna State	Maximum Allowed Power [dBm]	Conducted Power [dBm]	Power Drift [dB]	MPR [dB]	Device Serial Number	Modulation	RB Size	RB Offset	Spacing	Side	Duty Cycle	SAR (1g)	Scaling Factor	Reported SAR (1g)	Plot #	
		MHz	Ch.															(W/kg)		(W/kg)		
1 CC Uplink	N/A	836.50	20525	Mid	LTE Band 5 (Cell)	10	8	25.5	25.30	-0.02	0	04955	QPSK	1	0	10 mm	back	1:1	0.655	1.047	0.686	
1 CC Uplink	N/A	836.50	20525	Mid	LTE Band 5 (Cell)	10	8	24.5	24.22	-0.02	1	04955	QPSK	25	25	10 mm	back	1:1	0.538	1.067	0.574	
2 CC Uplink	PCC	836.50	20525	Mid	LTE Band 5 (Cell)	10	8	25.5	25.50	0.14	0	04955	QPSK	1	0	10 mm	back	1:1	0.662	1.000	0.662	A31
	SCC	829.30	20453	Mid	LTE Band 5 (Cell)	5									24	10 mm						
ANSI / IEEE C95.1 1992 - SAFETY LIMIT Spatial Peak Uncontrolled Exposure/General Population											Body 1.6 W/kg (mW/g) averaged over 1 gram											

FCC ID: ZNFG900VM	 PCTEST Proud to be part of 	SAR EVALUATION REPORT		Approved by: Quality Manager
Document S/N: 1M2006040088-01-R1.ZNF	Test Dates: 06/25/20 – 08/05/20	DUT Type: Portable Handset	Page 104 of 159	

**Table 11-22
NR Body-Worn SAR**

MEASUREMENT RESULTS																					
FREQUENCY		Mode	Bandwidth [MHz]	Antenna State	Maximum Allowed Power [dBm]	Conducted Power [dBm]	Power Drift [dB]	MPR [dB]	Antenna Config.	Device Serial Number	Modulation	RB Size	RB Offset	Spacing	Side	Duty Cycle	SAR (1g) (W/kg)	Scaling Factor	Reported SAR (1g) (W/kg)	Plot #	
MHz	Ch.																				
836.50	167300	Mid	NR Band n5 (Cell)	20	8	24.8	24.60	0.05	0	-	05002	DFT-S-OFDMQPSK	1	53	10 mm	back	1:1	0.547	1.047	0.573	
836.50	167300	Mid	NR Band n5 (Cell)	20	8	24.8	24.43	-0.01	0	-	05002	DFT-S-OFDMQPSK	50	28	10 mm	back	1:1	0.566	1.089	0.616	A37
836.50	167300	Mid	NR Band n5 (Cell)	20	8	23.3	22.59	0.03	1.5	-	05002	CP-OFDM QPSK	1	1	10 mm	back	1:1	0.370	1.178	0.436	
1720.00	344000	Low	NR Band n66 (AWS)	20	N/A	24.5	23.76	0.17	0	-	05002	DFT-S-OFDMQPSK	1	104	10 mm	back	1:1	0.397	1.186	0.471	
1720.00	344000	Low	NR Band n66 (AWS)	20	N/A	24.5	23.75	0.04	0	-	05002	DFT-S-OFDMQPSK	50	28	10 mm	back	1:1	0.418	1.189	0.497	A38
1745.00	349000	Mid	NR Band n66 (AWS)	20	N/A	24.0	23.15	-0.06	0.5	-	05002	CP-OFDM QPSK	1	1	10 mm	back	1:1	0.360	1.216	0.438	
1770.00	354000	High	NR Band n66 (AWS)	20	N/A	25.5	25.02	-0.07	0	#1	05002	DFT-S-OFDMQPSK	1	104	10 mm	back	1:1	0.295	1.117	0.330	
1860.00	372000	Low	NR Band n2 (PCS)	20	N/A	24.5	23.72	-0.08	0	-	05002	DFT-S-OFDMQPSK	1	1	10 mm	back	1:1	0.323	1.197	0.387	
1860.00	372000	Low	NR Band n2 (PCS)	20	N/A	24.5	23.62	-0.05	0	-	05002	DFT-S-OFDMQPSK	50	28	10 mm	back	1:1	0.330	1.225	0.404	A40
1860.00	372000	Low	NR Band n2 (PCS)	20	N/A	24.0	22.84	-0.04	0.5	-	05002	CP-OFDM QPSK	1	1	10 mm	back	1:1	0.270	1.306	0.353	
1860.00	372000	Low	NR Band n2 (PCS)	20	N/A	25.5	24.64	0.08	0	#1	05002	DFT-S-OFDMQPSK	1	1	10 mm	back	1:1	0.245	1.219	0.299	
ANSI / IEEE C95.1 1992 - SAFETY LIMIT Spatial Peak Uncontrolled Exposure/General Population										Body 1.6 W/kg (mW/g) averaged over 1 gram											



Note: 1) Light Green entries represent additional Body-Worn SAR Position (DD #1: 0 degrees)

**Table 11-23
DTS Body-Worn SAR**

MEASUREMENT RESULTS																			
FREQUENCY		Mode	Service	Bandwidth [MHz]	Maximum Allowed Power [dBm]	Conducted Power [dBm]	Power Drift [dB]	Spacing	Antenna Config.	Device Serial Number	Data Rate (Mbps)	Side	Duty Cycle (%)	Peak SAR of Area Scan (W/kg)	SAR (1g) (W/kg)	Scaling Factor (Power)	Scaling Factor (Duty Cycle)	Reported SAR (1g) (W/kg)	Plot #
MHz	Ch.																		
2437	6	802.11b	DSSS	22	20.5	19.84	-0.01	10 mm	1	04732	1	back	99.3	0.272	0.169	1.164	1.007	0.198	
2437	6	802.11b	DSSS	22	20.5	20.04	0.13	10 mm	2	04732	1	back	99.3	0.400	0.300	1.112	1.007	0.336	A42
ANSI / IEEE C95.1 1992 - SAFETY LIMIT Spatial Peak Uncontrolled Exposure/General Population										Body 1.6 W/kg (mW/g) averaged over 1 gram									

**Table 11-24
DTS Body-Worn SAR with 5G NR FR2 Active**

MEASUREMENT RESULTS																			
FREQUENCY		Mode	Service	Bandwidth [MHz]	Maximum Allowed Power [dBm]	Conducted Power [dBm]	Power Drift [dB]	Spacing	Antenna Config.	Device Serial Number	Data Rate (Mbps)	Side	Duty Cycle (%)	Peak SAR of Area Scan (W/kg)	SAR (1g) (W/kg)	Scaling Factor (Power)	Scaling Factor (Duty Cycle)	Reported SAR (1g) (W/kg)	Plot #
MHz	Ch.																		
2437	6	802.11b	DSSS	22	15.0	14.51	-0.01	10mm	1	04732	1	back	99.3	0.074	0.048	1.119	1.007	0.054	
2437	6	802.11b	DSSS	22	15.0	14.66	0.04	10mm	2	04732	1	back	99.3	0.161	0.096	1.081	1.007	0.105	
ANSI / IEEE C95.1 1992 - SAFETY LIMIT Spatial Peak Uncontrolled Exposure/General Population										Body 1.6 W/kg (mW/g) averaged over 1 gram									

FCC ID: ZNFG900VM	 Proud to be part of 	SAR EVALUATION REPORT		Approved by: Quality Manager
Document S/N: 1M2006040088-01-R1.ZNF	Test Dates: 06/25/20 – 08/05/20	DUT Type: Portable Handset		Page 105 of 159

**Table 11-25
NII Body-Worn SAR**

MEASUREMENT RESULTS																			
FREQUENCY		Mode	Service	Bandwidth [MHz]	Maximum Allowed Power [dBm]	Conducted Power [dBm]	Power Drift [dB]	Spacing	Antenna Config.	Device Serial Number	Data Rate (Mbps)	Side	Duty Cycle (%)	Peak SAR of Area Scan	SAR (1g)	Scaling Factor (Power)	Scaling Factor (Duty Cycle)	Reported SAR (1g)	Plot #
MHz	Ch.													W/kg	(W/kg)			(W/kg)	
5280	56	802.11a	OFDM	20	19.0	18.45	0.09	10 mm	1	04732	6	back	98.3	0.654	0.291	1.135	1.017	0.336	
5280	56	802.11a	OFDM	20	19.0	18.53	0.14	10 mm	2	04732	6	back	96.4	0.357	0.140	1.114	1.037	0.162	
5720	144	802.11a	OFDM	20	17.0	16.75	0.12	10 mm	1	04732	6	back	98.3	0.442	0.130	1.059	1.017	0.140	
5500	100	802.11a	OFDM	20	17.0	16.68	0.20	10 mm	2	04732	6	back	96.4	0.610	0.255	1.076	1.037	0.285	
5785	157	802.11a	OFDM	20	19.0	18.84	-0.05	10 mm	1	04732	6	back	98.3	0.536	0.230	1.038	1.017	0.243	
5825	165	802.11a	OFDM	20	19.0	18.51	0.16	10 mm	2	04732	6	back	96.4	0.371	0.134	1.119	1.037	0.155	
ANSI / IEEE C95.1 1992 - SAFETY LIMIT Spatial Peak Uncontrolled Exposure/General Population								Body 1.6 W/kg (mW/g) averaged over 1 gram											

**Table 11-26
NII Body-Worn SAR with 5G NR FR2 Active**

MEASUREMENT RESULTS																			
FREQUENCY		Mode	Service	Bandwidth [MHz]	Maximum Allowed Power [dBm]	Conducted Power [dBm]	Power Drift [dB]	Spacing	Antenna Config.	Device Serial Number	Data Rate (Mbps)	Side	Duty Cycle (%)	Peak SAR of Area Scan	SAR (1g)	Scaling Factor (Power)	Scaling Factor (Duty Cycle)	Reported SAR (1g)	Plot #
MHz	Ch.													W/kg	(W/kg)			(W/kg)	
5270	54	802.11n	OFDM	40	16.0	15.54	0.09	10 mm	1	04732	13.5	back	97.4	0.273	0.128	1.112	1.027	0.146	
5310	62	802.11n	OFDM	40	16.0	15.59	0.11	10 mm	2	04732	13.5	back	97.3	0.122	0.054	1.099	1.028	0.061	
5710	142	802.11n	OFDM	40	16.0	15.92	0.13	10 mm	1	04732	13.5	back	97.4	0.245	0.104	1.019	1.027	0.109	
5510	102	802.11n	OFDM	40	16.0	15.78	-0.01	10 mm	2	04732	13.5	back	97.3	0.482	0.203	1.052	1.028	0.220	
5795	159	802.11n	OFDM	40	16.0	15.93	0.07	10 mm	1	04732	13.5	back	97.4	0.263	0.117	1.016	1.027	0.122	
5795	159	802.11n	OFDM	40	16.0	15.66	0.20	10 mm	2	04732	13.5	back	97.3	0.177	0.079	1.081	1.028	0.088	
ANSI / IEEE C95.1 1992 - SAFETY LIMIT Spatial Peak Uncontrolled Exposure/General Population								Body 1.6 W/kg (mW/g) averaged over 1 gram											

**Table 11-27
NII MIMO Body-Worn SAR**

MEASUREMENT RESULTS																					
FREQUENCY		Mode	Service	Bandwidth [MHz]	Maximum Allowed Power (Ant 1) [dBm]	Conducted Power (Ant 1) [dBm]	Maximum Allowed Power (Ant 2) [dBm]	Conducted Power (Ant 2) [dBm]	Power Drift [dB]	Spacing	Antenna Config.	Device Serial Number	Data Rate (Mbps)	Side	Duty Cycle (%)	Peak SAR of Area Scan	SAR (1g)	Scaling Factor (Power)	Scaling Factor (Duty Cycle)	Reported SAR (1g)	Plot #
MHz	Ch.															W/kg	(W/kg)			(W/kg)	
5280	56	802.11n	OFDM	20	19.0	18.35	19.0	18.47	0.19	10 mm	MIMO	04732	13	back	98.2	0.797	0.407	1.161	1.018	0.481	
5720	144	802.11n	OFDM	20	17.0	16.69	17.0	16.44	0.20	10 mm	MIMO	04732	13	back	98.2	0.700	0.296	1.138	1.018	0.343	
5745	149	802.11n	OFDM	20	17.0	16.70	17.0	16.37	0.12	10 mm	MIMO	04732	13	back	98.2	0.668	0.292	1.156	1.018	0.344	
5785	157	802.11n	OFDM	20	19.0	18.70	19.0	18.37	-0.09	10 mm	MIMO	04732	13	back	98.2	0.901	0.516	1.156	1.018	0.807	A44
5825	165	802.11n	OFDM	20	19.0	18.62	19.0	18.44	0.12	10 mm	MIMO	04732	13	back	98.2	0.862	0.312	1.138	1.018	0.361	
ANSI / IEEE C95.1 1992 - SAFETY LIMIT Spatial Peak Uncontrolled Exposure/General Population								Body 1.6 W/kg (mW/g) averaged over 1 gram													

Note:



1. For channel 56, 157, 165 to achieve the 22.0 dBm maximum allowed MIMO power shown in the documentation, each antenna transmits at a maximum allowed power of 19.0 dBm. For channel 144, 149 to achieve the 20.0 dBm maximum allowed MIMO power shown in the documentation, each antenna transmits at a maximum allowed power of 17.0 dBm.

**Table 11-28
NII MIMO Body-Worn SAR with 5G NR FR2 Active**

MEASUREMENT RESULTS																					
FREQUENCY		Mode	Service	Bandwidth [MHz]	Maximum Allowed Power (Ant 1) [dBm]	Conducted Power (Ant 1) [dBm]	Maximum Allowed Power (Ant 2) [dBm]	Conducted Power (Ant 2) [dBm]	Power Drift [dB]	Spacing	Antenna Config.	Device Serial Number	Data Rate (Mbps)	Side	Duty Cycle (%)	Peak SAR of Area Scan	SAR (1g)	Scaling Factor (Power)	Scaling Factor (Duty Cycle)	Reported SAR (1g)	Plot #
MHz	Ch.															W/kg	(W/kg)			(W/kg)	
5270	54	802.11n	OFDM	40	16.0	15.54	16.0	15.44	0.19	10 mm	MIMO	04732	27	back	97.2	0.354	0.141	1.138	1.029	0.165	
5710	142	802.11n	OFDM	40	16.0	15.92	16.0	15.71	0.03	10 mm	MIMO	04750	27	back	97.2	0.537	0.231	1.069	1.029	0.254	
5795	159	802.11n	OFDM	40	16.0	15.93	16.0	15.66	-0.14	10 mm	MIMO	04732	27	back	97.2	0.420	0.162	1.081	1.029	0.202	
ANSI / IEEE C95.1 1992 - SAFETY LIMIT Spatial Peak Uncontrolled Exposure/General Population								Body 1.6 W/kg (mW/g) averaged over 1 gram													



Note:

1. For channels 54, 142, 159 to achieve the 19.0 dBm maximum allowed MIMO power shown in the documentation, each antenna transmits at a maximum allowed power of 16.0 dBm.

FCC ID: ZNFG900VM		SAR EVALUATION REPORT		Approved by: Quality Manager
Document S/N: 1M2006040088-01-R1.ZNF	Test Dates: 06/25/20 – 08/05/20	DUT Type: Portable Handset		Page 106 of 159

**Table 11-29
DSS Body-Worn SAR**

MEASUREMENT RESULTS																
FREQUENCY		Mode	Service	Maximum Allowed Power [dBm]	Conducted Power [dBm]	Power Drift [dB]	Spacing	Device Serial Number	Data Rate (Mbps)	Side	Duty Cycle (%)	SAR (1g)	Scaling Factor (Cond Power)	Scaling Factor (Duty Cycle)	Reported SAR	Plot #
MHz	Ch.											(W/kg)			(1g) (W/kg)	
2441	39	Bluetooth	FHSS	11.5	11.36	0.20	10 mm	04740	1	back	77.3	0.020	1.033	1.294	0.027	A46
ANSI / IEEE C95.1 1992 - SAFETY LIMIT Spatial Peak Uncontrolled Exposure/General Population							Body 1.6 W/kg (mW/g) averaged over 1 gram									

FCC ID: ZNFG900VM	 PCTEST Proud to be part of 	SAR EVALUATION REPORT		Approved by: Quality Manager
Document S/N: 1M2006040088-01-R1.ZNF	Test Dates: 06/25/20 – 08/05/20	DUT Type: Portable Handset	Page 107 of 159	



11.3 Standalone Hotspot SAR Data

**Table 11-30
GPRS/UMTS/CDMA Hotspot SAR Data**

MEASUREMENT RESULTS																	
FREQUENCY		Mode	Service	Maximum Allowed Power [dBm]	Conducted Power [dBm]	Power Drift [dB]	Spacing	Dual Display Accessory Configuration	Antenna State	Device Serial Number	# of Time Slots	Duty Cycle	Side	SAR (1g)	Scaling Factor	Reported SAR	Plot #
MHz	Ch.													(W/kg)		(1g) (W/kg)	
824.20	128	GSM 850	GPRS	32.0	31.46	-0.15	10 mm	-	N/A	04948	2	1:4.15	back	0.622	1.132	0.704	
836.60	190	GSM 850	GPRS	32.0	31.43	0.14	10 mm	-	N/A	04948	2	1:4.15	back	0.665	1.140	0.758	A19
848.80	251	GSM 850	GPRS	32.0	31.37	0.21	10 mm	-	N/A	04948	2	1:4.15	back	0.662	1.156	0.765	
836.60	190	GSM 850	GPRS	32.0	31.43	0.01	10 mm	-	N/A	04955	2	1:4.15	front	0.427	1.140	0.487	
836.60	190	GSM 850	GPRS	32.0	31.43	-0.01	10 mm	-	N/A	04955	2	1:4.15	bottom	0.191	1.140	0.218	
836.60	190	GSM 850	GPRS	32.0	31.43	-0.11	10 mm	-	N/A	04955	2	1:4.15	right	0.247	1.140	0.282	
1880.00	661	GSM 1900	GPRS	29.0	28.99	0.02	10 mm	-	N/A	04922	2	1:4.15	back	0.450	1.002	0.451	
1880.00	661	GSM 1900	GPRS	29.0	28.99	0.05	10 mm	-	N/A	04922	2	1:4.15	front	0.324	1.002	0.325	
1850.20	512	GSM 1900	GPRS	29.0	28.69	-0.04	10 mm	-	N/A	04922	2	1:4.15	bottom	0.728	1.074	0.782	
1880.00	661	GSM 1900	GPRS	29.0	28.99	-0.08	10 mm	-	N/A	04922	2	1:4.15	bottom	0.826	1.002	0.828	
1909.80	810	GSM 1900	GPRS	29.0	28.85	-0.01	10 mm	-	N/A	04922	2	1:4.15	bottom	0.951	1.035	0.984	A21
1909.80	810	GSM 1900	GPRS	29.0	28.85	-0.13	10 mm	#1	N/A	04922	2	1:4.15	bottom	0.295	1.035	0.305	
1909.80	810	GSM 1900	GPRS	29.0	28.85	-0.02	10 mm	#2	N/A	04922	2	1:4.15	bottom	0.264	1.035	0.273	
1909.80	810	GSM 1900	GPRS	29.0	28.85	0.08	10 mm	#3	N/A	04922	2	1:4.15	bottom	0.173	1.035	0.179	
1880.00	661	GSM 1900	GPRS	29.0	28.99	-0.01	10 mm	-	N/A	04922	2	1:4.15	left	0.114	1.002	0.114	
826.40	4132	UMTS 850	RMC	25.5	25.29	-0.02	10 mm	-	8	04955	N/A	1:1	back	0.657	1.050	0.690	
836.60	4183	UMTS 850	RMC	25.5	25.28	-0.03	10 mm	-	8	04955	N/A	1:1	back	0.707	1.052	0.744	A22
846.60	4233	UMTS 850	RMC	25.5	25.24	-0.02	10 mm	-	8	04955	N/A	1:1	back	0.687	1.062	0.730	
836.60	4183	UMTS 850	RMC	25.5	25.28	0.00	10 mm	-	8	04955	N/A	1:1	front	0.595	1.052	0.626	
836.60	4183	UMTS 850	RMC	25.5	25.28	-0.01	10 mm	-	8	04955	N/A	1:1	bottom	0.326	1.052	0.343	
836.60	4183	UMTS 850	RMC	25.5	25.28	-0.03	10 mm	-	8	04955	N/A	1:1	right	0.381	1.052	0.401	
1880.00	9400	UMTS 1900	RMC	22.5	22.05	0.11	10 mm	-	N/A	04914	N/A	1:1	back	0.644	1.109	0.714	
1880.00	9400	UMTS 1900	RMC	24.0	23.50	-0.01	10 mm	#1	N/A	04930	N/A	1:1	back	0.533	1.122	0.598	
1880.00	9400	UMTS 1900	RMC	22.5	22.05	0.01	10 mm	-	N/A	04914	N/A	1:1	front	0.522	1.109	0.579	
1880.00	9400	UMTS 1900	RMC	24.0	23.50	0.02	10 mm	#3	N/A	04930	N/A	1:1	front	0.604	1.122	0.678	
1852.40	9262	UMTS 1900	RMC	22.5	22.05	-0.06	10 mm	-	N/A	04914	N/A	1:1	bottom	0.892	1.109	0.989	
1880.00	9400	UMTS 1900	RMC	22.5	22.05	-0.07	10 mm	-	N/A	04914	N/A	1:1	bottom	1.010	1.109	1.120	A24
1907.60	9538	UMTS 1900	RMC	22.5	22.10	-0.04	10 mm	-	N/A	04914	N/A	1:1	bottom	0.940	1.096	1.030	
1852.40	9262	UMTS 1900	RMC	24.0	23.40	0.00	10 mm	#1	N/A	04922	N/A	1:1	bottom	0.745	1.148	0.855	
1880.00	9400	UMTS 1900	RMC	24.0	23.50	-0.05	10 mm	#1	N/A	04922	N/A	1:1	bottom	0.739	1.122	0.829	
1907.60	9538	UMTS 1900	RMC	24.0	23.48	0.05	10 mm	#1	N/A	04922	N/A	1:1	bottom	0.486	1.127	0.548	
1880.00	9400	UMTS 1900	RMC	22.5	22.05	-0.07	10 mm	-	N/A	04914	N/A	1:1	left	0.156	1.109	0.173	
1880.00	9400	UMTS 1900	RMC	24.0	23.50	0.02	10 mm	#1	N/A	04930	N/A	1:1	left	0.074	1.122	0.083	
824.70	1013	Cell. CDMA	EVDO Rev. 0	25.0	24.73	-0.04	10 mm	-	8	04955	N/A	1:1	back	0.544	1.194	0.650	
836.52	384	Cell. CDMA	EVDO Rev. 0	25.5	24.82	-0.13	10 mm	-	8	04955	N/A	1:1	back	0.671	1.169	0.784	A26
848.31	777	Cell. CDMA	EVDO Rev. 0	25.5	24.81	-0.01	10 mm	-	8	04955	N/A	1:1	back	0.583	1.172	0.683	
836.52	384	Cell. CDMA	EVDO Rev. 0	25.5	24.82	-0.01	10 mm	-	8	04955	N/A	1:1	front	0.637	1.169	0.745	
836.52	384	Cell. CDMA	EVDO Rev. 0	25.5	24.82	-0.03	10 mm	-	8	04955	N/A	1:1	bottom	0.294	1.169	0.344	
836.52	384	Cell. CDMA	EVDO Rev. 0	25.5	24.82	0.03	10 mm	-	8	04955	N/A	1:1	right	0.332	1.169	0.388	
1880.00	600	PCS CDMA	EVDO Rev. 0	22.5	22.36	0.12	10 mm	-	N/A	04922	N/A	1:1	back	0.596	1.033	0.616	
1880.00	600	PCS CDMA	EVDO Rev. 0	25.0	24.90	0.08	10 mm	#1	N/A	04930	N/A	1:1	back	0.656	1.023	0.671	
1880.00	600	PCS CDMA	EVDO Rev. 0	22.5	22.36	0.07	10 mm	-	N/A	04922	N/A	1:1	front	0.396	1.033	0.409	
1880.00	600	PCS CDMA	EVDO Rev. 0	25.0	24.90	-0.04	10 mm	#3	N/A	04930	N/A	1:1	front	0.662	1.023	0.677	
1851.25	25	PCS CDMA	EVDO Rev. 0	22.5	22.31	-0.02	10 mm	-	N/A	04914	N/A	1:1	bottom	0.892	1.045	0.932	
1880.00	600	PCS CDMA	EVDO Rev. 0	22.5	22.36	-0.05	10 mm	-	N/A	04914	N/A	1:1	bottom	0.978	1.033	1.010	A28
1908.75	1175	PCS CDMA	EVDO Rev. 0	22.5	22.34	-0.02	10 mm	-	N/A	04914	N/A	1:1	bottom	0.918	1.038	0.953	
1851.25	25	PCS CDMA	EVDO Rev. 0	25.0	24.86	0.01	10 mm	#1	N/A	04930	N/A	1:1	bottom	0.763	1.033	0.788	
1880.00	600	PCS CDMA	EVDO Rev. 0	25.0	24.90	0.00	10 mm	#1	N/A	04930	N/A	1:1	bottom	0.672	1.023	0.687	
1908.75	1175	PCS CDMA	EVDO Rev. 0	25.0	25.00	0.01	10 mm	#1	N/A	04930	N/A	1:1	bottom	0.492	1.000	0.492	
1880.00	600	PCS CDMA	EVDO Rev. 0	22.5	22.36	-0.08	10 mm	-	N/A	04922	N/A	1:1	left	0.134	1.033	0.138	
1880.00	600	PCS CDMA	EVDO Rev. 0	25.0	24.90	0.07	10 mm	#1	N/A	04930	N/A	1:1	left	0.070	1.023	0.072	

ANSI / IEEE C95.1 1992 - SAFETY LIMIT
Spatial Peak
Uncontrolled Exposure/General Population
Body
1.6 W/kg (mW/g)
averaged over 1 gram

Note: 1) Green entries represent additional Hotspot SAR Position (DD #1: 0 degrees) 2) Light purple entries represent additional Hotspot SAR Position (DD #2: 180 degrees) 3) Light orange entries represent additional Hotspot SAR Position (DD #3: 360 degrees)

FCC ID: ZNFG900VM	 PCTEST Proud to be part of element	SAR EVALUATION REPORT	 LG	Approved by: Quality Manager
Document S/N: 1M2006040088-01-R1.ZNF	Test Dates: 06/25/20 – 08/05/20	DUT Type: Portable Handset	Page 108 of 159	

**Table 11-31
LTE Band 12 Hotspot SAR**



MEASUREMENT RESULTS																				
FREQUENCY		Mode	Bandwidth [MHz]	Antenna State	Maximum Allowed Power [dBm]	Conducted Power [dBm]	Power Drift [dB]	MPR [dB]	Device Serial Number	Modulation	RB Size	RB Offset	Spacing	Side	Duty Cycle	SAR (1g) (W/kg)	Scaling Factor	Reported SAR (1g) (W/kg)	Plot #	
MHz	Ch.																			
707.50	23095	Mid	LTE Band 12	10	12	25.5	25.13	-0.03	0	04922	QPSK	1	25	10 mm	back	1:1	0.298	1.089	0.325	A29
707.50	23095	Mid	LTE Band 12	10	12	24.5	24.16	-0.01	1	04922	QPSK	25	12	10 mm	back	1:1	0.243	1.081	0.263	
707.50	23095	Mid	LTE Band 12	10	12	25.5	25.13	0.01	0	04922	QPSK	1	25	10 mm	front	1:1	0.258	1.089	0.281	
707.50	23095	Mid	LTE Band 12	10	12	24.5	24.16	0.00	1	04922	QPSK	25	12	10 mm	front	1:1	0.210	1.081	0.227	
707.50	23095	Mid	LTE Band 12	10	12	25.5	25.13	-0.01	0	04922	QPSK	1	25	10 mm	bottom	1:1	0.120	1.089	0.131	
707.50	23095	Mid	LTE Band 12	10	12	24.5	24.16	-0.05	1	04922	QPSK	25	12	10 mm	bottom	1:1	0.098	1.081	0.106	
707.50	23095	Mid	LTE Band 12	10	12	25.5	25.13	-0.09	0	04922	QPSK	1	25	10 mm	right	1:1	0.118	1.089	0.129	
707.50	23095	Mid	LTE Band 12	10	12	24.5	24.16	-0.06	1	04922	QPSK	25	12	10 mm	right	1:1	0.096	1.081	0.104	
ANSI / IEEE C95.1 1992 - SAFETY LIMIT Spatial Peak Uncontrolled Exposure/General Population											Body 1.6 W/kg (mW/g) averaged over 1 gram									

**Table 11-32
LTE Band 13 Hotspot SAR**

MEASUREMENT RESULTS																				
FREQUENCY		Mode	Bandwidth [MHz]	Antenna State	Maximum Allowed Power [dBm]	Conducted Power [dBm]	Power Drift [dB]	MPR [dB]	Device Serial Number	Modulation	RB Size	RB Offset	Spacing	Side	Duty Cycle	SAR (1g) (W/kg)	Scaling Factor	Reported SAR (1g) (W/kg)	Plot #	
MHz	Ch.																			
782.00	23230	Mid	LTE Band 13	10	3	25.5	24.94	0.15	0	04922	QPSK	1	25	10 mm	back	1:1	0.541	1.138	0.616	A30
782.00	23230	Mid	LTE Band 13	10	3	24.5	24.21	-0.02	1	04922	QPSK	25	25	10 mm	back	1:1	0.447	1.069	0.478	
782.00	23230	Mid	LTE Band 13	10	3	25.5	24.94	-0.02	0	04922	QPSK	1	25	10 mm	front	1:1	0.470	1.138	0.535	
782.00	23230	Mid	LTE Band 13	10	3	24.5	24.21	-0.01	1	04922	QPSK	25	25	10 mm	front	1:1	0.385	1.069	0.412	
782.00	23230	Mid	LTE Band 13	10	3	25.5	24.94	-0.10	0	04922	QPSK	1	25	10 mm	bottom	1:1	0.190	1.138	0.216	
782.00	23230	Mid	LTE Band 13	10	3	24.5	24.21	-0.09	1	04922	QPSK	25	25	10 mm	bottom	1:1	0.154	1.069	0.165	
782.00	23230	Mid	LTE Band 13	10	3	25.5	24.94	-0.07	0	04922	QPSK	1	25	10 mm	right	1:1	0.229	1.138	0.261	
782.00	23230	Mid	LTE Band 13	10	3	24.5	24.21	-0.09	1	04922	QPSK	25	25	10 mm	right	1:1	0.181	1.069	0.193	
ANSI / IEEE C95.1 1992 - SAFETY LIMIT Spatial Peak Uncontrolled Exposure/General Population											Body 1.6 W/kg (mW/g) averaged over 1 gram									

**Table 11-33
LTE Band 5 (Cell) Hotspot SAR**

MEASUREMENT RESULTS																						
1 CC Uplink 2 CC Uplink	Component Carrier	FREQUENCY		Mode	Bandwidth [MHz]	Antenna State	Maximum Allowed Power [dBm]	Conducted Power [dBm]	Power Drift [dB]	MPR [dB]	Device Serial Number	Modulation	RB Size	RB Offset	Spacing	Side	Duty Cycle	SAR (1g) (W/kg)	Scaling Factor	Reported SAR (1g) (W/kg)	Plot #	
		MHz	Ch.																			
1 CC Uplink	N/A	836.50	20525	Mid	LTE Band 5 (Cell)	10	8	25.5	25.30	-0.02	0	04955	QPSK	1	0	10 mm	back	1:1	0.655	1.047	0.686	
1 CC Uplink	N/A	836.50	20525	Mid	LTE Band 5 (Cell)	10	8	24.5	24.22	-0.02	1	04955	QPSK	25	25	10 mm	back	1:1	0.538	1.067	0.574	
2 CC Uplink	PCC	836.50	20525	Mid	LTE Band 5 (Cell)	10	8	25.5	25.50	0.14	0	04955	QPSK	1	0	10 mm	back	1:1	0.662	1.000	0.662	A31
	SCC	829.30	20453	Mid	LTE Band 5 (Cell)									5	1							
1 CC Uplink	N/A	836.50	20525	Mid	LTE Band 5 (Cell)	10	8	25.5	25.30	0.01	0	04955	QPSK	1	0	10 mm	front	1:1	0.590	1.047	0.618	
1 CC Uplink	N/A	836.50	20525	Mid	LTE Band 5 (Cell)	10	8	24.5	24.22	0.05	1	04955	QPSK	25	25	10 mm	front	1:1	0.485	1.067	0.517	
1 CC Uplink	N/A	836.50	20525	Mid	LTE Band 5 (Cell)	10	8	25.5	25.30	-0.01	0	04955	QPSK	1	0	10 mm	bottom	1:1	0.297	1.047	0.311	
1 CC Uplink	N/A	836.50	20525	Mid	LTE Band 5 (Cell)	10	8	24.5	24.22	0.03	1	04955	QPSK	25	25	10 mm	bottom	1:1	0.241	1.067	0.257	
1 CC Uplink	N/A	836.50	20525	Mid	LTE Band 5 (Cell)	10	8	25.5	25.30	-0.03	0	04955	QPSK	1	0	10 mm	right	1:1	0.413	1.047	0.432	
1 CC Uplink	N/A	836.50	20525	Mid	LTE Band 5 (Cell)	10	8	24.5	24.22	-0.04	1	04955	QPSK	25	25	10 mm	right	1:1	0.341	1.067	0.364	
ANSI / IEEE C95.1 1992 - SAFETY LIMIT Spatial Peak Uncontrolled Exposure/General Population											Body 1.6 W/kg (mW/g) averaged over 1 gram											

FCC ID: ZNFG900VM		SAR EVALUATION REPORT		Approved by: Quality Manager
Document S/N: 1M2006040088-01-R1.ZNF	Test Dates: 06/25/20 – 08/05/20	DUT Type: Portable Handset		Page 109 of 159

**Table 11-34
LTE Band 66 (AWS) Hotspot SAR**



MEASUREMENT RESULTS																				
FREQUENCY		Mode	Bandwidth [MHz]	Maximum Allowed Power [dBm]	Conducted Power [dBm]	Power Drift [dB]	MPR [dB]	Dual Display Accessory Configuration	Device Serial Number	Modulation	RB Size	RB Offset	Spacing	Side	Duty Cycle	SAR(1g) (W/kg)	Scaling Factor	Reported SAR (1g) (W/kg)	Plot #	
MHz	Ch.																			
1770.00	132572	High	LTE Band 66 (AWS)	20	24.0	23.96	0.08	0	-	04930	QPSK	1	0	10 mm	back	1:1	0.600	1.009	0.605	
1770.00	132572	High	LTE Band 66 (AWS)	20	24.0	23.96	0.08	0	-	04930	QPSK	50	25	10 mm	back	1:1	0.640	1.009	0.646	
1770.00	132572	High	LTE Band 66 (AWS)	20	25.0	25.00	0.01	0	#1	04948	QPSK	1	0	10 mm	back	1:1	0.787	1.000	0.787	
1770.00	132572	High	LTE Band 66 (AWS)	20	24.0	23.96	0.02	0	-	04930	QPSK	1	0	10 mm	front	1:1	0.453	1.009	0.457	
1770.00	132572	High	LTE Band 66 (AWS)	20	24.0	23.96	-0.01	0	-	04930	QPSK	50	25	10 mm	front	1:1	0.485	1.009	0.489	
1720.00	132072	Low	LTE Band 66 (AWS)	20	25.0	24.98	0.00	0	#3	04948	QPSK	1	50	10 mm	front	1:1	0.762	1.005	0.766	
1745.00	132322	Mid	LTE Band 66 (AWS)	20	25.0	24.99	0.03	0	#3	04948	QPSK	1	50	10 mm	front	1:1	0.766	1.002	0.768	
1770.00	132572	High	LTE Band 66 (AWS)	20	25.0	25.00	0.02	0	#3	04948	QPSK	1	0	10 mm	front	1:1	0.802	1.000	0.802	
1720.00	132072	Low	LTE Band 66 (AWS)	20	24.0	23.52	-0.01	0	-	04930	QPSK	1	50	10 mm	bottom	1:1	0.772	1.117	0.862	
1745.00	132322	Mid	LTE Band 66 (AWS)	20	24.0	23.83	-0.03	0	-	04930	QPSK	1	50	10 mm	bottom	1:1	0.833	1.040	0.866	
1770.00	132572	High	LTE Band 66 (AWS)	20	24.0	23.96	0.02	0	-	04930	QPSK	1	0	10 mm	bottom	1:1	0.897	1.009	0.905	
1720.00	132072	Low	LTE Band 66 (AWS)	20	25.0	24.98	-0.01	0	#1	04948	QPSK	1	50	10 mm	bottom	1:1	0.707	1.005	0.711	
1745.00	132322	Mid	LTE Band 66 (AWS)	20	25.0	24.99	-0.05	0	#1	04948	QPSK	1	50	10 mm	bottom	1:1	0.815	1.002	0.817	
1770.00	132572	High	LTE Band 66 (AWS)	20	25.0	25.00	-0.05	0	#1	04948	QPSK	1	0	10 mm	bottom	1:1	0.907	1.000	0.907	
1720.00	132072	Low	LTE Band 66 (AWS)	20	24.0	23.85	0.04	0	-	04930	QPSK	50	25	10 mm	bottom	1:1	0.821	1.035	0.850	
1745.00	132322	Mid	LTE Band 66 (AWS)	20	24.0	23.93	0.04	0	-	04930	QPSK	50	25	10 mm	bottom	1:1	0.855	1.016	0.869	
1770.00	132572	High	LTE Band 66 (AWS)	20	24.0	23.96	0.03	0	-	04930	QPSK	50	25	10 mm	bottom	1:1	0.940	1.009	0.948	A33
1770.00	132572	High	LTE Band 66 (AWS)	20	24.0	23.91	0.02	0	-	04930	QPSK	100	0	10 mm	bottom	1:1	0.903	1.021	0.922	
1770.00	132572	High	LTE Band 66 (AWS)	20	24.0	23.96	-0.07	0	-	04930	QPSK	1	0	10 mm	left	1:1	0.204	1.009	0.206	
1770.00	132572	High	LTE Band 66 (AWS)	20	24.0	23.96	-0.02	0	-	04930	QPSK	50	25	10 mm	left	1:1	0.203	1.009	0.205	
1770.00	132572	High	LTE Band 66 (AWS)	20	25.0	25.00	-0.02	0	#1	04948	QPSK	1	0	10 mm	left	1:1	0.127	1.000	0.127	
1770.00	132572	High	LTE Band 66 (AWS)	20	24.0	23.96	0.03	0	-	04930	QPSK	50	25	10 mm	bottom	1:1	0.938	1.009	0.946	
ANSI / IEEE C95.1 1992 - SAFETY LIMIT										Body										
Spatial Peak										1.6 W/kg (mW/g)										
Uncontrolled Exposure/General Population										averaged over 1 gram										

Note: 1) Blue entry represents variability measurement. 2) Green entries represent additional Hotspot SAR Position (DD #1: 0 degrees) 3) Light orange entries represent additional Hotspot SAR Position (DD #3: 360 degrees)

**Table 11-35
LTE Band 2 (PCS) Hotspot SAR**

MEASUREMENT RESULTS																				
FREQUENCY		Mode	Bandwidth [MHz]	Maximum Allowed Power [dBm]	Conducted Power [dBm]	Power Drift [dB]	MPR [dB]	Dual Display Accessory Configuration	Device Serial Number	Modulation	RB Size	RB Offset	Spacing	Side	Duty Cycle	SAR(1g) (W/kg)	Scaling Factor	Reported SAR (1g) (W/kg)	Plot #	
MHz	Ch.																			
1890.00	18900	Mid	LTE Band 2 (PCS)	20	23.0	22.61	0.01	0	-	04914	QPSK	1	0	10 mm	back	1:1	0.600	1.094	0.656	
1890.00	18900	Mid	LTE Band 2 (PCS)	20	23.0	22.60	-0.01	0	-	04914	QPSK	50	50	10 mm	back	1:1	0.616	1.096	0.675	
1860.00	18700	Low	LTE Band 2 (PCS)	20	25.0	24.99	-0.02	0	#1	04922	QPSK	1	50	10 mm	back	1:1	0.695	1.002	0.696	
1890.00	18900	Mid	LTE Band 2 (PCS)	20	23.0	22.61	-0.01	0	-	04914	QPSK	1	0	10 mm	front	1:1	0.457	1.094	0.500	
1890.00	18900	Mid	LTE Band 2 (PCS)	20	23.0	22.60	-0.01	0	-	04914	QPSK	50	50	10 mm	front	1:1	0.468	1.096	0.513	
1860.00	18700	Low	LTE Band 2 (PCS)	20	25.0	24.99	0.02	0	#3	04922	QPSK	1	50	10 mm	front	1:1	0.779	1.002	0.781	
1890.00	18700	Low	LTE Band 2 (PCS)	20	23.0	22.24	-0.02	0	-	04914	QPSK	1	99	10 mm	bottom	1:1	0.661	1.191	1.025	
1890.00	18900	Mid	LTE Band 2 (PCS)	20	23.0	22.61	-0.05	0	-	04914	QPSK	1	0	10 mm	bottom	1:1	0.908	1.094	0.993	
1900.00	19100	High	LTE Band 2 (PCS)	20	23.0	22.31	-0.04	0	-	04914	QPSK	1	99	10 mm	bottom	1:1	0.860	1.172	1.008	
1860.00	18700	Low	LTE Band 2 (PCS)	20	23.0	22.32	-0.03	0	-	04914	QPSK	50	25	10 mm	bottom	1:1	0.899	1.169	1.051	
1890.00	18900	Mid	LTE Band 2 (PCS)	20	23.0	22.60	-0.01	0	-	04914	QPSK	50	50	10 mm	bottom	1:1	0.921	1.096	1.009	
1900.00	19100	High	LTE Band 2 (PCS)	20	23.0	22.30	-0.03	0	-	04914	QPSK	50	50	10 mm	bottom	1:1	0.932	1.151	1.073	A35
1860.00	18700	Low	LTE Band 2 (PCS)	20	23.0	22.32	-0.04	0	-	04914	QPSK	100	0	10 mm	bottom	1:1	0.878	1.169	1.026	
1860.00	18700	Low	LTE Band 2 (PCS)	20	25.0	24.99	-0.03	0	#1	04922	QPSK	1	50	10 mm	bottom	1:1	0.801	1.002	0.803	
1890.00	18900	Mid	LTE Band 2 (PCS)	20	25.0	24.97	-0.05	0	#1	04922	QPSK	1	0	10 mm	bottom	1:1	0.769	1.007	0.774	
1900.00	19100	High	LTE Band 2 (PCS)	20	25.0	24.97	-0.14	0	#1	04922	QPSK	1	0	10 mm	bottom	1:1	0.635	1.007	0.639	
1890.00	18900	Mid	LTE Band 2 (PCS)	20	23.0	22.61	-0.01	0	-	04914	QPSK	1	0	10 mm	left	1:1	0.163	1.094	0.178	
1890.00	18900	Mid	LTE Band 2 (PCS)	20	23.0	22.60	-0.01	0	-	04914	QPSK	50	50	10 mm	left	1:1	0.172	1.096	0.189	
1860.00	18700	Low	LTE Band 2 (PCS)	20	25.0	24.99	-0.01	0	#1	04922	QPSK	1	50	10 mm	left	1:1	0.085	1.002	0.085	
ANSI / IEEE C95.1 1992 - SAFETY LIMIT										Body										
Spatial Peak										1.6 W/kg (mW/g)										
Uncontrolled Exposure/General Population										averaged over 1 gram										

Note: 1) Green entries represent additional Hotspot SAR Position (DD #1: 0 degrees) 2) Light orange entries represent additional Hotspot SAR Position (DD #3: 360 degrees)

FCC ID: ZNFG900VM		SAR EVALUATION REPORT		Approved by: Quality Manager
Document S/N: 1M2006040088-01-R1.ZNF	Test Dates: 06/25/20 – 08/05/20	DUT Type: Portable Handset		Page 110 of 159



**Table 11-36
LTE Band 48 Hotspot SAR**

MEASUREMENT RESULTS																				
FREQUENCY		Mode	Bandwidth [MHz]	Dual Display Accessory Configuration	Maximum Allowed Power [dBm]	Conducted Power [dBm]	Power Drift [dB]	MPR [dB]	Device Serial Number	Modulation	RB Size	RB Offset	Spacing	Side	Duty Cycle	SAR (1g)	Scaling Factor	Reported SAR (1g)	Plot #	
MHz	Ch.															(W/kg)		(W/kg)		
3560.00	55340	Low	LTE Band 48	20	-	23.5	23.01	0.12	0	04948	QPSK	1	50	10 mm	back	1:1.58	0.150	1.119	0.168	
3560.00	55340	Low	LTE Band 48	20	#1	24.5	24.00	0.13	0	04948	QPSK	1	0	10 mm	back	1:1.58	0.180	1.122	0.202	A36
3560.00	55340	Low	LTE Band 48	20	-	23.5	23.10	0.14	0	04948	QPSK	50	25	10 mm	back	1:1.58	0.150	1.096	0.164	
3560.00	55340	Low	LTE Band 48	20	-	23.5	23.01	0.14	0	04948	QPSK	1	50	10 mm	front	1:1.58	0.021	1.119	0.023	
3560.00	55340	Low	LTE Band 48	20	#3	24.5	24.00	-0.06	0	04948	QPSK	1	0	10 mm	front	1:1.58	0.068	1.122	0.076	
3560.00	55340	Low	LTE Band 48	20	-	23.5	23.10	-0.13	0	04948	QPSK	50	25	10 mm	front	1:1.58	0.020	1.096	0.022	
3560.00	55340	Low	LTE Band 48	20	-	23.5	23.01	-0.09	0	04948	QPSK	1	50	10 mm	top	1:1.58	0.035	1.119	0.039	
3560.00	55340	Low	LTE Band 48	20	#1	24.5	24.00	0.06	0	04948	QPSK	1	0	10 mm	top	1:1.58	0.052	1.122	0.058	
3560.00	55340	Low	LTE Band 48	20	-	23.5	23.10	0.16	0	04948	QPSK	50	25	10 mm	top	1:1.58	0.035	1.096	0.038	
3560.00	55340	Low	LTE Band 48	20	-	23.5	23.01	-0.02	0	04948	QPSK	1	50	10 mm	right	1:1.58	0.134	1.119	0.150	
3560.00	55340	Low	LTE Band 48	20	#1	24.5	24.00	-0.12	0	04948	QPSK	1	0	10 mm	right	1:1.58	0.157	1.122	0.176	
3560.00	55340	Low	LTE Band 48	20	-	23.5	23.10	0.07	0	04948	QPSK	50	25	10 mm	right	1:1.58	0.112	1.096	0.123	
ANSI / IEEE C95.1 1992 - SAFETY LIMIT Spatial Peak											Body 1.6 W/kg (mW/g) averaged over 1 gram									
Uncontrolled Exposure/General Population																				

Note: 1) Light Green entries represent additional Hotspot SAR Position (DD #1: 0 degrees). 2) Light Orange entries represent additional Hotspot SAR Position (DD #3: 360 degrees)

**Table 11-37
NR Band n5 (Cell) Hotspot SAR**

MEASUREMENT RESULTS																				
FREQUENCY		Mode	Bandwidth [MHz]	Antenna State	Maximum Allowed Power [dBm]	Conducted Power [dBm]	Power Drift [dB]	MPR [dB]	Device Serial Number	Modulation	RB Size	RB Offset	Spacing	Side	Duty Cycle	SAR (1g)	Scaling Factor	Reported SAR (1g)	Plot #	
MHz	Ch.															(W/kg)		(W/kg)		
836.50	167300	Mid	NR Band n5 (Cell)	20	8	24.8	24.60	0.05	0	05002	DFT-S-OFDM QPSK	1	53	10 mm	back	1:1	0.547	1.047	0.573	
836.50	167300	Mid	NR Band n5 (Cell)	20	8	24.8	24.43	-0.01	0	05002	DFT-S-OFDM QPSK	50	28	10 mm	back	1:1	0.566	1.089	0.616	A37
836.50	167300	Mid	NR Band n5 (Cell)	20	8	23.3	22.59	0.03	1.5	05002	CP-OFDM QPSK	1	1	10 mm	back	1:1	0.370	1.178	0.436	
836.50	167300	Mid	NR Band n5 (Cell)	20	8	24.8	24.60	-0.07	0	05002	DFT-S-OFDM QPSK	1	53	10 mm	front	1:1	0.538	1.047	0.563	
836.50	167300	Mid	NR Band n5 (Cell)	20	8	24.8	24.43	0.05	0	05002	DFT-S-OFDM QPSK	50	28	10 mm	front	1:1	0.556	1.089	0.605	
836.50	167300	Mid	NR Band n5 (Cell)	20	8	24.8	24.60	-0.02	0	05002	DFT-S-OFDM QPSK	1	53	10 mm	bottom	1:1	0.267	1.047	0.280	
836.50	167300	Mid	NR Band n5 (Cell)	20	8	24.8	24.43	0.02	0	05002	DFT-S-OFDM QPSK	50	28	10 mm	bottom	1:1	0.278	1.089	0.303	
836.50	167300	Mid	NR Band n5 (Cell)	20	8	24.8	24.60	0.00	0	05002	DFT-S-OFDM QPSK	1	53	10 mm	right	1:1	0.332	1.047	0.348	
836.50	167300	Mid	NR Band n5 (Cell)	20	8	24.8	24.43	0.05	0	05002	DFT-S-OFDM QPSK	50	28	10 mm	right	1:1	0.337	1.089	0.367	
ANSI / IEEE C95.1 1992 - SAFETY LIMIT Spatial Peak											Body 1.6 W/kg (mW/g) averaged over 1 gram									
Uncontrolled Exposure/General Population																				

FCC ID: ZNFG900VM	 PCTEST Proud to be part of 	SAR EVALUATION REPORT		Approved by: Quality Manager
Document S/N: 1M2006040088-01-R1.ZNF	Test Dates: 06/25/20 – 08/05/20	DUT Type: Portable Handset	Page 111 of 159	

**Table 11-38
NR Band n66 (AWS) Hotspot SAR**



MEASUREMENT RESULTS																				
FREQUENCY		Mode	Bandwidth [MHz]	Maximum Allowed Power [dBm]	Conducted Power [dBm]	Power Drift [dB]	MPR [dB]	Dual Display Accessory Configuration	Device Serial Number	Modulation	RB Size	RB Offset	Spacing	Side	Duty Cycle	SAR (1g)	Scaling Factor	Reported SAR (1g)	Plot #	
MHz	Ch.															(W/kg)		(W/kg)		
1720.00	344000	Low	NR Band n66 (AWS)	20	24.5	23.76	0.17	0	-	05002	DFT-S-OFDM QPSK	1	104	10 mm	back	1:1	0.397	1.186	0.471	
1720.00	344000	Low	NR Band n66 (AWS)	20	24.5	23.75	0.04	0	-	05002	DFT-S-OFDM QPSK	50	28	10 mm	back	1:1	0.418	1.189	0.497	
1770.00	354000	High	NR Band n66 (AWS)	20	25.5	25.02	-0.07	0	#1	05002	DFT-S-OFDM QPSK	1	104	10 mm	back	1:1	0.295	1.117	0.330	
1720.00	344000	Low	NR Band n66 (AWS)	20	24.5	23.76	-0.04	0	-	05002	DFT-S-OFDM QPSK	1	104	10 mm	front	1:1	0.294	1.186	0.349	
1720.00	344000	Low	NR Band n66 (AWS)	20	24.5	23.75	-0.01	0	-	05002	DFT-S-OFDM QPSK	50	28	10 mm	front	1:1	0.287	1.189	0.341	
1770.00	354000	High	NR Band n66 (AWS)	20	25.5	25.02	-0.12	0	#3	05002	DFT-S-OFDM QPSK	1	104	10 mm	front	1:1	0.297	1.117	0.332	
1720.00	344000	Low	NR Band n66 (AWS)	20	24.5	23.76	0.13	0	-	05002	DFT-S-OFDM QPSK	1	104	10 mm	right	1:1	0.760	1.186	0.901	
1745.00	349000	Mid	NR Band n66 (AWS)	20	24.5	23.66	-0.11	0	-	05002	DFT-S-OFDM QPSK	1	1	10 mm	right	1:1	0.808	1.213	0.980	
1770.00	354000	High	NR Band n66 (AWS)	20	24.5	23.71	0.06	0	-	05002	DFT-S-OFDM QPSK	1	104	10 mm	right	1:1	0.812	1.199	0.974	
1720.00	344000	Low	NR Band n66 (AWS)	20	24.5	23.75	0.04	0	-	05002	DFT-S-OFDM QPSK	50	28	10 mm	right	1:1	0.695	1.189	0.826	
1745.00	349000	Mid	NR Band n66 (AWS)	20	24.5	23.70	0.05	0	-	05002	DFT-S-OFDM QPSK	50	28	10 mm	right	1:1	0.828	1.202	0.995	
1770.00	354000	High	NR Band n66 (AWS)	20	24.5	23.62	-0.16	0	-	05002	DFT-S-OFDM QPSK	50	28	10 mm	right	1:1	0.801	1.225	0.981	
1745.00	349000	Mid	NR Band n66 (AWS)	20	24.5	23.60	-0.04	0	-	05002	DFT-S-OFDM QPSK	100	0	10 mm	right	1:1	0.806	1.230	0.991	
1745.00	349000	Mid	NR Band n66 (AWS)	20	24.0	23.15	0.04	0.5	-	05002	CP-OFDM QPSK	1	1	10 mm	right	1:1	0.689	1.216	0.838	
1720.00	344000	Low	NR Band n66 (AWS)	20	25.5	25.01	0.00	0	#1	05002	DFT-S-OFDM QPSK	1	104	10 mm	right	1:1	0.765	1.119	0.856	
1745.00	349000	Mid	NR Band n66 (AWS)	20	25.5	25.01	-0.06	0	#1	05002	DFT-S-OFDM QPSK	1	104	10 mm	right	1:1	0.846	1.119	0.947	A39
1770.00	354000	High	NR Band n66 (AWS)	20	25.5	25.02	-0.02	0	#1	05002	DFT-S-OFDM QPSK	1	104	10 mm	right	1:1	0.794	1.117	0.887	
ANSI / IEEE C95.1 1992 - SAFETY LIMIT										Body										
Spatial Peak										1.6 W/kg (mW/g)										
Uncontrolled Exposure/General Population										averaged over 1 gram										

Note: 1) Light Green entries represent additional Hotspot SAR Position (DD #1: 0 degrees). 2) Light Orange entries represent additional Hotspot SAR Position (DD #3: 360 degrees)

**Table 11-39
NR Band n2 (PCS) Hotspot SAR**



MEASUREMENT RESULTS																				
FREQUENCY		Mode	Bandwidth [MHz]	Maximum Allowed Power [dBm]	Conducted Power [dBm]	Power Drift [dB]	MPR [dB]	Dual Display Accessory Configuration	Device Serial Number	Modulation	RB Size	RB Offset	Spacing	Side	Duty Cycle	SAR (1g)	Scaling Factor	Reported SAR (1g)	Plot #	
MHz	Ch.															(W/kg)		(W/kg)		
1860.00	372000	Low	NR Band n2 (PCS)	20	24.5	23.72	-0.08	0	-	05002	DFT-S-OFDM QPSK	1	1	10 mm	back	1:1	0.323	1.197	0.387	
1860.00	372000	Low	NR Band n2 (PCS)	20	24.5	23.62	-0.05	0	-	05002	DFT-S-OFDM QPSK	50	28	10 mm	back	1:1	0.330	1.225	0.404	
1860.00	372000	Low	NR Band n2 (PCS)	20	25.5	24.64	0.08	0	#1	05002	DFT-S-OFDM QPSK	1	1	10 mm	back	1:1	0.245	1.219	0.299	
1860.00	372000	Low	NR Band n2 (PCS)	20	24.5	23.72	-0.06	0	-	05002	DFT-S-OFDM QPSK	1	1	10 mm	front	1:1	0.289	1.197	0.346	
1860.00	372000	Low	NR Band n2 (PCS)	20	24.5	23.62	-0.03	0	-	05002	DFT-S-OFDM QPSK	50	28	10 mm	front	1:1	0.287	1.225	0.352	
1860.00	372000	Low	NR Band n2 (PCS)	20	25.5	24.64	0.05	0	#3	05002	DFT-S-OFDM QPSK	1	1	10 mm	front	1:1	0.276	1.219	0.336	
1860.00	372000	Low	NR Band n2 (PCS)	20	24.5	23.72	-0.07	0	-	05002	DFT-S-OFDM QPSK	1	1	10 mm	right	1:1	0.693	1.197	0.830	A41
1880.00	376000	Mid	NR Band n2 (PCS)	20	24.5	23.61	-0.04	0	-	05002	DFT-S-OFDM QPSK	1	104	10 mm	right	1:1	0.629	1.227	0.772	
1900.00	380000	High	NR Band n2 (PCS)	20	24.5	23.62	-0.06	0	-	05002	DFT-S-OFDM QPSK	1	104	10 mm	right	1:1	0.574	1.225	0.703	
1860.00	372000	Low	NR Band n2 (PCS)	20	24.5	23.62	-0.09	0	-	05002	DFT-S-OFDM QPSK	50	28	10 mm	right	1:1	0.671	1.225	0.822	
1860.00	372000	Low	NR Band n2 (PCS)	20	24.0	22.84	-0.07	0.5	-	05002	CP-OFDM QPSK	1	1	10 mm	right	1:1	0.565	1.306	0.738	
1880.00	376000	Mid	NR Band n2 (PCS)	20	24.5	23.58	-0.08	0	-	05002	DFT-S-OFDM QPSK	50	28	10 mm	right	1:1	0.604	1.236	0.747	
1900.00	380000	High	NR Band n2 (PCS)	20	24.5	23.59	-0.09	0	-	05002	DFT-S-OFDM QPSK	50	28	10 mm	right	1:1	0.615	1.233	0.758	
1860.00	372000	Low	NR Band n2 (PCS)	20	24.5	23.49	-0.04	0	-	05002	DFT-S-OFDM QPSK	100	0	10 mm	right	1:1	0.652	1.262	0.823	
1860.00	372000	Low	NR Band n2 (PCS)	20	25.5	24.64	-0.05	0	#1	05002	DFT-S-OFDM QPSK	1	1	10 mm	right	1:1	0.582	1.219	0.709	
1880.00	376000	Mid	NR Band n2 (PCS)	20	25.5	24.57	-0.09	0	#1	05002	DFT-S-OFDM QPSK	1	104	10 mm	right	1:1	0.512	1.239	0.634	
1900.00	380000	High	NR Band n2 (PCS)	20	25.5	24.61	-0.11	0	#1	05002	DFT-S-OFDM QPSK	1	104	10 mm	right	1:1	0.522	1.227	0.640	
ANSI / IEEE C95.1 1992 - SAFETY LIMIT										Body										
Spatial Peak										1.6 W/kg (mW/g)										
Uncontrolled Exposure/General Population										averaged over 1 gram										

Note: 1) Green entries represent additional Hotspot SAR Position (DD #1: 0 degrees) 2) Light orange entries represent additional Hotspot SAR Position (DD #3: 360 degrees)

FCC ID: ZNFG900VM	 PCTEST Proud to be part of element	SAR EVALUATION REPORT		Approved by: Quality Manager
Document S/N: 1M2006040088-01-R1.ZNF	Test Dates: 06/25/20 – 08/05/20	DUT Type: Portable Handset		Page 112 of 159

**Table 11-40
WLAN Hotspot SAR**

MEASUREMENT RESULTS																			
FREQUENCY		Mode	Service	Bandwidth [MHz]	Maximum Allowed Power [dBm]	Conducted Power [dBm]	Power Drift [dB]	Spacing	Antenna Config.	Device Serial Number	Data Rate (Mbps)	Side	Duty Cycle (%)	Peak SAR of Area Scan [W/kg]	SAR (1g) [W/kg]	Scaling Factor (Power)	Scaling Factor (Duty Cycle)	Reported SAR (1g) [W/kg]	Plot #
MHz	Ch.																		
2437	6	802.11b	DSSS	22	20.5	19.84	-0.01	10 mm	1	04732	1	back	99.3	0.272	0.169	1.164	1.007	0.198	
2437	6	802.11b	DSSS	22	20.5	19.84	-0.01	10 mm	1	04732	1	front	99.3	0.222	0.152	1.164	1.007	0.178	
2437	6	802.11b	DSSS	22	20.5	19.84	-0.05	10 mm	1	04732	1	top	99.3	0.321	0.208	1.164	1.007	0.244	
2437	6	802.11b	DSSS	22	20.5	19.84	-0.01	10 mm	1	04732	1	left	99.3	0.579	0.365	1.164	1.007	0.428	
2437	6	802.11b	DSSS	22	20.5	20.04	0.13	10 mm	2	04732	1	back	99.3	0.400	0.300	1.112	1.007	0.336	
2437	6	802.11b	DSSS	22	20.5	20.04	-0.05	10 mm	2	04732	1	front	99.3	0.338	0.240	1.112	1.007	0.269	
2437	6	802.11b	DSSS	22	20.5	20.04	0.00	10 mm	2	04732	1	top	99.3	0.672	0.427	1.112	1.007	0.478	A43
2437	6	802.11b	DSSS	22	20.5	20.04	0.07	10 mm	2	04732	1	left	99.3	0.088	-	1.112	1.007	-	
5200	40	802.11a	OFDM	20	19.0	18.59	0.06	10 mm	1	04732	6	back	98.3	0.750	0.441	1.099	1.017	0.493	A45
5200	40	802.11a	OFDM	20	19.0	18.59	0.16	10 mm	1	04732	6	front	98.3	0.277	-	1.099	1.017	-	
5200	40	802.11a	OFDM	20	19.0	18.59	0.05	10 mm	1	04732	6	top	98.3	0.398	0.244	1.099	1.017	0.273	
5200	40	802.11a	OFDM	20	19.0	18.59	-0.15	10 mm	1	04732	6	left	98.3	0.324	-	1.099	1.017	-	
5200	40	802.11a	OFDM	20	19.0	18.59	-0.16	10 mm	2	04732	6	back	96.4	0.396	0.234	1.099	1.037	0.267	
5200	40	802.11a	OFDM	20	19.0	18.59	-0.12	10 mm	2	04732	6	front	96.4	0.294	-	1.099	1.037	-	
5200	40	802.11a	OFDM	20	19.0	18.59	0.00	10 mm	2	04732	6	top	96.4	0.279	-	1.099	1.037	-	
5200	40	802.11a	OFDM	20	19.0	18.59	0.14	10 mm	2	04732	6	left	96.4	0.216	-	1.099	1.037	-	
5785	157	802.11a	OFDM	20	19.0	18.84	-0.05	10 mm	1	04732	6	back	98.3	0.536	0.230	1.038	1.017	0.243	
5785	157	802.11a	OFDM	20	19.0	18.84	0.19	10 mm	1	04732	6	front	98.3	0.180	-	1.038	1.017	-	
5785	157	802.11a	OFDM	20	19.0	18.84	-0.18	10 mm	1	04732	6	top	98.3	0.267	-	1.038	1.017	-	
5785	157	802.11a	OFDM	20	19.0	18.84	0.18	10 mm	1	04732	6	left	98.3	0.276	-	1.038	1.017	-	
5825	165	802.11a	OFDM	20	19.0	18.51	0.16	10 mm	2	04732	6	back	96.4	0.371	0.134	1.119	1.037	0.155	
5825	165	802.11a	OFDM	20	19.0	18.51	0.19	10 mm	2	04732	6	front	96.4	0.083	-	1.119	1.037	-	
5825	165	802.11a	OFDM	20	19.0	18.51	-0.11	10 mm	2	04732	6	top	96.4	0.307	-	1.119	1.037	-	
5825	165	802.11a	OFDM	20	19.0	18.51	0.16	10 mm	2	04732	6	left	96.4	0.279	-	1.119	1.037	-	
ANSI / IEEE C95.1 1992 - SAFETY LIMIT Spatial Peak Uncontrolled Exposure/General Population								Body 1.6 W/kg (mW/g) averaged over 1 gram											

FCC ID: ZNFG900VM	 Proud to be part of 	SAR EVALUATION REPORT		Approved by: Quality Manager
Document S/N: 1M2006040088-01-R1.ZNF	Test Dates: 06/25/20 – 08/05/20	DUT Type: Portable Handset		Page 113 of 159

**Table 11-41
WLAN Hotspot SAR with 5G NR FR2 Active**



MEASUREMENT RESULTS																			
FREQUENCY		Mode	Service	Bandwidth [MHz]	Maximum Allowed Power [dBm]	Conducted Power [dBm]	Power Drift [dB]	Spacing	Antenna Config.	Device Serial Number	Data Rate (Mbps)	Side	Duty Cycle (%)	Peak SAR of Area Scan [W/kg]	SAR (1g) [W/kg]	Scaling Factor (Power)	Scaling Factor (Duty Cycle)	Reported SAR (1g) [W/kg]	Plot #
MHz	Ch.																		
2437	6	802.11b	DSSS	22	15.0	14.51	-0.01	10 mm	1	04732	1	back	99.3	0.074	0.048	1.119	1.007	0.054	
2437	6	802.11b	DSSS	22	15.0	14.51	0.16	10 mm	1	04732	1	front	99.3	0.060	-	1.119	1.007	-	
2437	6	802.11b	DSSS	22	15.0	14.51	0.04	10 mm	1	04732	1	top	99.3	0.083	0.051	1.119	1.007	0.057	
2437	6	802.11b	DSSS	22	15.0	14.51	0.08	10 mm	1	04732	1	left	99.3	0.133	0.080	1.119	1.007	0.090	
2437	6	802.11b	DSSS	22	15.0	14.66	0.04	10 mm	2	04732	1	back	99.3	0.161	0.096	1.081	1.007	0.105	
2437	6	802.11b	DSSS	22	15.0	14.66	0.13	10 mm	2	04732	1	front	99.3	0.093	-	1.081	1.007	-	
2437	6	802.11b	DSSS	22	15.0	14.66	0.13	10 mm	2	04732	1	top	99.3	0.229	0.138	1.081	1.007	0.150	
2437	6	802.11b	DSSS	22	15.0	14.66	0.10	10 mm	2	04732	1	left	99.3	0.030	0.020	1.081	1.007	0.022	
5190	38	802.11n	OFDM	40	16.0	15.71	0.18	10 mm	1	04732	13.5	back	97.4	0.327	0.166	1.069	1.027	0.182	
5190	38	802.11n	OFDM	40	16.0	15.71	0.18	10 mm	1	04732	13.5	left	97.4	0.144	0.059	1.069	1.027	0.065	
5230	46	802.11n	OFDM	40	16.0	15.48	0.18	10 mm	2	04732	13.5	back	97.3	0.132	0.058	1.127	1.028	0.067	
5230	46	802.11n	OFDM	40	16.0	15.48	0.06	10 mm	2	04732	13.5	left	97.3	0.050	0.018	1.127	1.028	0.021	
5795	159	802.11n	OFDM	40	16.0	15.93	0.07	10 mm	1	04732	13.5	back	97.4	0.263	0.117	1.016	1.027	0.122	
5795	159	802.11n	OFDM	40	16.0	15.93	0.16	10 mm	1	04732	13.5	left	97.4	0.064	0.025	1.016	1.027	0.026	
5795	159	802.11n	OFDM	40	16.0	15.66	0.20	10 mm	2	04732	13.5	back	97.3	0.177	0.079	1.081	1.028	0.088	
5795	159	802.11n	OFDM	40	16.0	15.66	0.01	10 mm	2	04732	13.5	left	97.3	0.117	0.038	1.081	1.028	0.042	
ANSI / IEEE C95.1 1992 - SAFETY LIMIT Spatial Peak Uncontrolled Exposure/General Population										Body 1.6 W/kg (mW/g) averaged over 1 gram									

**Table 11-42
WLAN MIMO Hotspot SAR with 5G NR FR2 Active**

MEASUREMENT RESULTS																					
FREQUENCY		Mode	Service	Bandwidth [MHz]	Maximum Allowed Power (Ant 1) [dBm]	Conducted Power (Ant 1) [dBm]	Maximum Allowed Power (Ant 2) [dBm]	Conducted Power (Ant 2) [dBm]	Power Drift [dB]	Spacing	Antenna Config.	Device Serial Number	Data Rate (Mbps)	Side	Duty Cycle (%)	Peak SAR of Area Scan [W/kg]	SAR (1g) [W/kg]	Scaling Factor (Power)	Scaling Factor (Duty Cycle)	Reported SAR (1g) [W/kg]	Plot #
MHz	Ch.																				
5230	46	802.11n	OFDM	40	16.0	15.70	16.0	15.48	0.08	10 mm	MIMO	04732	27	back	97.2	0.414	0.188	1.127	1.029	0.218	
5230	46	802.11n	OFDM	40	16.0	15.70	16.0	15.48	-0.20	10 mm	MIMO	04732	27	front	97.2	0.145	-	1.127	1.029	-	
5230	46	802.11n	OFDM	40	16.0	15.70	16.0	15.48	0.16	10 mm	MIMO	04732	27	top	97.2	0.281	-	1.127	1.029	-	
5230	46	802.11n	OFDM	40	16.0	15.70	16.0	15.48	0.17	10 mm	MIMO	04732	27	left	97.2	0.234	0.163	1.127	1.029	0.189	
5795	159	802.11n	OFDM	40	16.0	15.93	16.0	15.66	-0.14	10 mm	MIMO	04732	27	back	97.2	0.420	0.182	1.081	1.029	0.202	
5795	159	802.11n	OFDM	40	16.0	15.93	16.0	15.66	0.00	10 mm	MIMO	04732	27	front	97.2	0.049	-	1.081	1.029	-	
5795	159	802.11n	OFDM	40	16.0	15.93	16.0	15.66	0.13	10 mm	MIMO	04732	27	top	97.2	0.219	-	1.081	1.029	-	
5795	159	802.11n	OFDM	40	16.0	15.93	16.0	15.66	0.12	10 mm	MIMO	04732	27	left	97.2	0.163	0.060	1.081	1.029	0.067	
ANSI / IEEE C95.1 1992 - SAFETY LIMIT Spatial Peak Uncontrolled Exposure/General Population										Body 1.6 W/kg (mW/g) averaged over 1 gram											



Note:

1. For channels 46, 159 to achieve the 19.0 dBm maximum allowed MIMO power shown in the documentation, each antenna transmits at a maximum allowed power of 16.0 dBm.

FCC ID: ZNFG900VM	 PCTEST Proud to be part of 	SAR EVALUATION REPORT		Approved by: Quality Manager
Document S/N: 1M2006040088-01-R1.ZNF	Test Dates: 06/25/20 – 08/05/20	DUT Type: Portable Handset	Page 114 of 159	

**Table 11-43
DSS Hotspot SAR**

MEASUREMENT RESULTS																
FREQUENCY		Mode	Service	Maximum Allowed Power [dBm]	Conducted Power [dBm]	Power Drift [dB]	Spacing	Device Serial Number	Data Rate (Mbps)	Side	Duty Cycle (%)	SAR (1g) (W/kg)	Scaling Factor (Cond Power)	Scaling Factor (Duty Cycle)	Reported SAR (1g) (W/kg)	Plot #
MHz	Ch.															
2441	39	Bluetooth	FHSS	11.5	11.36	0.20	10 mm	04740	1	back	77.3	0.020	1.033	1.294	0.027	
2441	39	Bluetooth	FHSS	11.5	11.36	-0.09	10 mm	04740	1	front	77.3	0.015	1.033	1.294	0.020	
2441	39	Bluetooth	FHSS	11.5	11.36	0.15	10 mm	04740	1	top	77.3	0.021	1.033	1.294	0.028	
2441	39	Bluetooth	FHSS	11.5	11.36	-0.01	10 mm	04740	1	left	77.3	0.043	1.033	1.294	0.057	A47
ANSI / IEEE C95.1 1992 - SAFETY LIMIT Spatial Peak Uncontrolled Exposure/General Population							Body 1.6 W/kg (mW/g) averaged over 1 gram									



FCC ID: ZNFG900VM	 PCTEST Proud to be part of 	SAR EVALUATION REPORT		Approved by: Quality Manager
Document S/N: 1M2006040088-01-R1.ZNF	Test Dates: 06/25/20 – 08/05/20	DUT Type: Portable Handset	Page 115 of 159	

11.4 Standalone Phablet SAR Data

**Table 11-44
CDMA Phablet SAR Data**

MEASUREMENT RESULTS															
FREQUENCY		Mode	Service	Maximum Allowed Power [dBm]	Conducted Power [dBm]	Power Drift [dB]	Spacing	Dual Display Accessory Configuration	Device Serial Number	Duty Cycle	Side	SAR (10g)	Scaling Factor	Reported SAR (10g)	Plot #
MHz	Ch.											(W/kg)		(W/kg)	
1851.25	25	PCS CDMA	EVDO Rev. 0	25.5	24.79	0.13	2 mm	-	04922	1:1	back	1.920	1.178	2.262	
1880.00	600	PCS CDMA	EVDO Rev. 0	25.5	24.81	0.15	2 mm	-	04922	1:1	back	1.890	1.172	2.215	
1908.75	1175	PCS CDMA	EVDO Rev. 0	25.5	24.92	0.15	2 mm	-	04922	1:1	back	1.830	1.143	2.092	
1880.00	600	PCS CDMA	EVDO Rev. 0	25.5	24.81	0.04	1 mm	-	04922	1:1	front	1.690	1.172	1.981	
1851.25	25	PCS CDMA	EVDO Rev. 0	25.5	24.79	-0.03	4 mm	-	04922	1:1	bottom	2.020	1.178	2.380	
1880.00	600	PCS CDMA	EVDO Rev. 0	25.5	24.81	-0.06	4 mm	-	04922	1:1	bottom	2.260	1.172	2.649	
1908.75	1175	PCS CDMA	EVDO Rev. 0	25.5	24.92	-0.06	4 mm	-	04922	1:1	bottom	2.370	1.143	2.709	
1880.00	600	PCS CDMA	EVDO Rev. 0	25.5	24.81	-0.09	0 mm	-	04922	1:1	left	0.602	1.172	0.706	
1880.00	600	PCS CDMA	EVDO Rev. 0	25.0	24.90	0.06	0 mm	#1	04930	1:1	left	0.221	1.023	0.226	
1851.25	25	PCS CDMA	EVDO Rev. 0	22.5	22.31	-0.02	0 mm	-	04914	1:1	back	1.980	1.045	2.069	
1880.00	600	PCS CDMA	EVDO Rev. 0	22.5	22.36	-0.02	0 mm	-	04914	1:1	back	2.030	1.033	2.097	
1908.75	1175	PCS CDMA	EVDO Rev. 0	22.5	22.34	-0.01	0 mm	-	04914	1:1	back	1.950	1.038	2.024	
1851.25	25	PCS CDMA	EVDO Rev. 0	25.0	24.86	-0.13	0 mm	#1	04930	1:1	back	2.640	1.033	2.727	
1880.00	600	PCS CDMA	EVDO Rev. 0	25.0	24.90	-0.04	0 mm	#1	04930	1:1	back	2.730	1.023	2.793	
1908.75	1175	PCS CDMA	EVDO Rev. 0	25.0	25.00	-0.08	0 mm	#1	04930	1:1	back	2.580	1.000	2.580	
1880.00	600	PCS CDMA	EVDO Rev. 0	22.5	22.36	-0.14	0 mm	-	04914	1:1	front	1.680	1.033	1.735	
1880.00	600	PCS CDMA	EVDO Rev. 0	25.0	24.90	-0.04	0 mm	#3	04930	1:1	front	1.570	1.023	1.606	
1851.25	25	PCS CDMA	EVDO Rev. 0	22.5	22.31	-0.14	0 mm	-	04914	1:1	bottom	2.410	1.045	2.518	
1880.00	600	PCS CDMA	EVDO Rev. 0	22.5	22.36	0.03	0 mm	-	04914	1:1	bottom	2.470	1.033	2.552	
1908.75	1175	PCS CDMA	EVDO Rev. 0	22.5	22.34	-0.15	0 mm	-	04914	1:1	bottom	2.660	1.038	2.761	
1851.25	25	PCS CDMA	EVDO Rev. 0	25.0	24.86	-0.02	0 mm	#1	04930	1:1	bottom	2.670	1.033	2.758	
1880.00	600	PCS CDMA	EVDO Rev. 0	25.0	24.90	0.04	0 mm	#1	04930	1:1	bottom	2.790	1.023	2.854	A48
1908.75	1175	PCS CDMA	EVDO Rev. 0	25.0	25.00	0.01	0 mm	#1	04930	1:1	bottom	2.700	1.000	2.700	
ANSI / IEEE C95.1 1992 - SAFETY LIMIT Spatial Peak Uncontrolled Exposure/General Population								Phablet 4.0 W/kg (mW/g) averaged over 10 grams							



Note: 1) Green entries represent additional Phablet SAR Position (DD #1: 0 degrees) 2) Light orange entries represent additional Phablet SAR Position (DD #3: 360 degrees)

FCC ID: ZNFG900VM	 PCTEST Proud to be part of 	SAR EVALUATION REPORT		Approved by: Quality Manager
Document S/N: 1M2006040088-01-R1.ZNF	Test Dates: 06/25/20 – 08/05/20	DUT Type: Portable Handset	Page 116 of 159	

**Table 11-45
UMTS Phablet SAR Data**

MEASUREMENT RESULTS															
FREQUENCY		Mode	Service	Maximum Allowed Power [dBm]	Conducted Power [dBm]	Power Drift [dB]	Spacing	Dual Display Accessory Configuration	Device Serial Number	Duty Cycle	Side	SAR (10g)	Scaling Factor	Reported SAR (10g)	Plot #
MHz	Ch.											(W/kg)		(W/kg)	
1852.40	9262	UMTS 1900	RMC	25.5	25.19	0.12	2 mm	-	04914	1:1	back	2.370	1.074	2.545	
1880.00	9400	UMTS 1900	RMC	25.5	25.25	0.21	2 mm	-	04914	1:1	back	2.430	1.059	2.573	
1907.60	9538	UMTS 1900	RMC	25.5	25.23	0.13	2 mm	-	04914	1:1	back	2.410	1.064	2.564	
1852.40	9262	UMTS 1900	RMC	25.5	25.19	-0.02	1 mm	-	04914	1:1	front	2.180	1.074	2.341	
1880.00	9400	UMTS 1900	RMC	25.5	25.25	-0.04	1 mm	-	04914	1:1	front	2.270	1.059	2.404	
1907.60	9538	UMTS 1900	RMC	25.5	25.23	0.00	1 mm	-	04914	1:1	front	2.220	1.064	2.362	
1852.40	9262	UMTS 1900	RMC	25.5	25.19	-0.05	4 mm	-	04914	1:1	bottom	2.170	1.074	2.331	
1880.00	9400	UMTS 1900	RMC	25.5	25.25	-0.06	4 mm	-	04914	1:1	bottom	2.450	1.059	2.595	
1907.60	9538	UMTS 1900	RMC	25.5	25.23	-0.09	4 mm	-	04914	1:1	bottom	2.590	1.064	2.756	
1880.00	9400	UMTS 1900	RMC	25.5	25.25	0.14	0 mm	-	04914	1:1	left	0.877	1.059	0.929	
1880.00	9400	UMTS 1900	RMC	24.0	23.50	-0.03	0 mm	#1	04930	1:1	left	0.266	1.122	0.298	
1852.40	9262	UMTS 1900	RMC	22.5	22.05	-0.01	0 mm	-	04914	1:1	back	1.970	1.109	2.185	
1880.00	9400	UMTS 1900	RMC	22.5	22.05	-0.02	0 mm	-	04914	1:1	back	1.990	1.109	2.207	
1907.60	9538	UMTS 1900	RMC	22.5	22.10	-0.01	0 mm	-	04914	1:1	back	1.990	1.096	2.181	
1852.40	9262	UMTS 1900	RMC	24.0	23.40	-0.11	0 mm	#1	04930	1:1	back	2.540	1.148	2.916	
1880.00	9400	UMTS 1900	RMC	24.0	23.50	-0.14	0 mm	#1	04930	1:1	back	2.440	1.122	2.738	
1907.60	9538	UMTS 1900	RMC	24.0	23.48	-0.15	0 mm	#1	04930	1:1	back	2.300	1.127	2.592	
1880.00	9400	UMTS 1900	RMC	22.5	22.05	-0.03	0 mm	-	04914	1:1	front	1.660	1.109	1.841	
1880.00	9400	UMTS 1900	RMC	24.0	23.50	-0.21	0 mm	#3	04930	1:1	front	1.380	1.122	1.548	
1852.40	9262	UMTS 1900	RMC	22.5	22.05	-0.09	0 mm	-	04914	1:1	bottom	2.420	1.109	2.684	
1880.00	9400	UMTS 1900	RMC	22.5	22.05	0.14	0 mm	-	04914	1:1	bottom	2.450	1.109	2.717	
1907.60	9538	UMTS 1900	RMC	22.5	22.10	-0.08	0 mm	-	04914	1:1	bottom	2.620	1.096	2.872	
1852.40	9262	UMTS 1900	RMC	24.0	23.40	-0.11	0 mm	#1	04930	1:1	bottom	2.600	1.148	2.985	
1880.00	9400	UMTS 1900	RMC	24.0	23.50	-0.08	0 mm	#1	04930	1:1	bottom	2.700	1.122	3.029	A49
1907.60	9538	UMTS 1900	RMC	24.0	23.48	-0.07	0 mm	#1	04930	1:1	bottom	2.620	1.127	2.953	
ANSI / IEEE C95.1 1992 - SAFETY LIMIT Spatial Peak Uncontrolled Exposure/General Population							Phablet 4.0 W/kg (mW/g) averaged over 10 grams								



Note: 1) Green entries represent additional Phablet SAR Position (DD #1: 0 degrees) 2) Light orange entries represent additional Phablet SAR Position (DD #3: 360 degrees)

FCC ID: ZNFG900VM	 PCTEST Proud to be part of 	SAR EVALUATION REPORT		Approved by: Quality Manager
Document S/N: 1M2006040088-01-R1.ZNF	Test Dates: 06/25/20 – 08/05/20	DUT Type: Portable Handset	Page 117 of 159	

**Table 11-46
LTE Band 66 (AWS) Phablet SAR**

MEASUREMENT RESULTS																				
FREQUENCY		Mode	Bandwidth [MHz]	Maximum Allowed Power [dBm]	Conducted Power [dBm]	Power Drift [dB]	MPR [dB]	Dual Display Accessory Configuration	Serial Number	Modulation	RB Size	RB Offset	Spacing	Side	Duty Cycle	SAR (10g) (W/kg)	Scaling Factor	Reported SAR (10g) (W/kg)	Plot #	
MHz	Ch.																			
1720.00	132072	Low	LTE Band 66 (AWS)	20	25.5	25.10	0.20	0	-	04930	QPSK	1	50	2 mm	back	1:1	2.060	1.096	2.258	
1745.00	132322	Mid	LTE Band 66 (AWS)	20	25.5	25.02	0.19	0	-	04930	QPSK	1	50	2 mm	back	1:1	2.010	1.117	2.245	
1770.00	132572	High	LTE Band 66 (AWS)	20	25.5	25.32	0.20	0	-	04930	QPSK	1	0	2 mm	back	1:1	2.120	1.042	2.209	
1770.00	132572	High	LTE Band 66 (AWS)	20	24.5	24.26	0.12	1	-	04930	QPSK	50	25	2 mm	back	1:1	1.800	1.057	1.903	
1770.00	132572	High	LTE Band 66 (AWS)	20	24.5	24.25	0.21	1	-	04930	QPSK	100	0	2 mm	back	1:1	1.710	1.059	1.811	
1770.00	132572	High	LTE Band 66 (AWS)	20	25.5	25.32	-0.02	0	-	04930	QPSK	1	0	1 mm	front	1:1	1.910	1.042	1.990	
1770.00	132572	High	LTE Band 66 (AWS)	20	24.5	24.26	-0.03	1	-	04930	QPSK	50	25	1 mm	front	1:1	1.600	1.057	1.691	
1770.00	132572	High	LTE Band 66 (AWS)	20	25.5	25.32	-0.02	0	-	04930	QPSK	1	0	4 mm	bottom	1:1	1.700	1.042	1.771	
1770.00	132572	High	LTE Band 66 (AWS)	20	24.5	24.26	-0.02	1	-	04930	QPSK	50	25	4 mm	bottom	1:1	1.420	1.057	1.501	
1770.00	132572	High	LTE Band 66 (AWS)	20	25.5	25.32	0.07	0	-	04930	QPSK	1	0	0 mm	left	1:1	0.749	1.042	0.780	
1770.00	132572	High	LTE Band 66 (AWS)	20	24.5	24.26	0.06	1	-	04930	QPSK	50	25	0 mm	left	1:1	0.623	1.057	0.659	
1770.00	132572	High	LTE Band 66 (AWS)	20	25.0	25.00	0.01	0	#1	04948	QPSK	1	0	0 mm	left	1:1	0.256	1.000	0.256	
1720.00	132072	Low	LTE Band 66 (AWS)	20	24.0	23.52	0.10	0	-	04930	QPSK	1	50	0 mm	back	1:1	2.360	1.117	2.636	
1745.00	132322	Mid	LTE Band 66 (AWS)	20	24.0	23.83	0.11	0	-	04930	QPSK	1	50	0 mm	back	1:1	2.450	1.040	2.548	
1770.00	132572	High	LTE Band 66 (AWS)	20	24.0	23.96	0.10	0	-	04930	QPSK	1	0	0 mm	back	1:1	2.560	1.009	2.583	
1720.00	132072	Low	LTE Band 66 (AWS)	20	25.0	24.98	0.16	0	#1	04948	QPSK	1	50	0 mm	back	1:1	2.520	1.005	2.533	
1745.00	132322	Mid	LTE Band 66 (AWS)	20	25.0	24.99	0.17	0	#1	04948	QPSK	1	50	0 mm	back	1:1	2.710	1.002	2.715	
1770.00	132572	High	LTE Band 66 (AWS)	20	25.0	25.00	0.19	0	#1	04948	QPSK	1	0	0 mm	back	1:1	2.850	1.000	2.850	A50
1720.00	132072	Low	LTE Band 66 (AWS)	20	24.0	23.85	0.09	0	-	04930	QPSK	50	25	0 mm	back	1:1	2.520	1.035	2.608	
1745.00	132322	Mid	LTE Band 66 (AWS)	20	24.0	23.93	0.09	0	-	04930	QPSK	50	25	0 mm	back	1:1	2.530	1.016	2.570	
1770.00	132572	High	LTE Band 66 (AWS)	20	24.0	23.96	0.12	0	-	04930	QPSK	50	25	0 mm	back	1:1	2.690	1.009	2.714	
1770.00	132572	High	LTE Band 66 (AWS)	20	24.0	23.91	0.10	0	-	04930	QPSK	100	0	0 mm	back	1:1	2.600	1.021	2.655	
1720.00	132072	Low	LTE Band 66 (AWS)	20	24.0	23.52	0.16	0	-	04930	QPSK	1	50	0 mm	front	1:1	2.100	1.117	2.346	
1745.00	132322	Mid	LTE Band 66 (AWS)	20	24.0	23.83	-0.04	0	-	04930	QPSK	1	50	0 mm	front	1:1	2.050	1.040	2.132	
1770.00	132572	High	LTE Band 66 (AWS)	20	24.0	23.96	-0.02	0	-	04930	QPSK	1	0	0 mm	front	1:1	2.100	1.009	2.119	
1720.00	132072	Low	LTE Band 66 (AWS)	20	25.0	24.98	0.09	0	#3	04948	QPSK	1	50	0 mm	front	1:1	2.220	1.005	2.231	
1745.00	132322	Mid	LTE Band 66 (AWS)	20	25.0	24.99	0.07	0	#3	04948	QPSK	1	50	0 mm	front	1:1	2.220	1.002	2.224	
1770.00	132572	High	LTE Band 66 (AWS)	20	25.0	25.00	0.18	0	#3	04948	QPSK	1	0	0 mm	front	1:1	2.330	1.000	2.330	
1720.00	132072	Low	LTE Band 66 (AWS)	20	24.0	23.85	-0.03	0	-	04930	QPSK	50	25	0 mm	front	1:1	2.180	1.035	2.256	
1745.00	132322	Mid	LTE Band 66 (AWS)	20	24.0	23.93	-0.02	0	-	04930	QPSK	50	25	0 mm	front	1:1	2.120	1.016	2.154	
1770.00	132572	High	LTE Band 66 (AWS)	20	24.0	23.96	-0.04	0	-	04930	QPSK	50	25	0 mm	front	1:1	2.240	1.009	2.260	
1770.00	132572	High	LTE Band 66 (AWS)	20	24.0	23.91	-0.04	0	-	04930	QPSK	100	0	0 mm	front	1:1	2.160	1.021	2.205	
1720.00	132072	Low	LTE Band 66 (AWS)	20	24.0	23.52	0.01	0	-	04930	QPSK	1	50	0 mm	bottom	1:1	2.440	1.117	2.725	
1745.00	132322	Mid	LTE Band 66 (AWS)	20	24.0	23.83	0.02	0	-	04930	QPSK	1	50	0 mm	bottom	1:1	2.540	1.040	2.642	
1770.00	132572	High	LTE Band 66 (AWS)	20	24.0	23.96	0.01	0	-	04930	QPSK	1	0	0 mm	bottom	1:1	2.610	1.009	2.633	
1720.00	132072	Low	LTE Band 66 (AWS)	20	25.0	24.98	-0.19	0	#1	04948	QPSK	1	50	0 mm	bottom	1:1	1.700	1.005	1.709	
1745.00	132322	Mid	LTE Band 66 (AWS)	20	25.0	24.99	-0.14	0	#1	04948	QPSK	1	50	0 mm	bottom	1:1	1.850	1.002	1.854	
1770.00	132572	High	LTE Band 66 (AWS)	20	25.0	25.00	-0.16	0	#1	04948	QPSK	1	0	0 mm	bottom	1:1	2.060	1.000	2.060	
1720.00	132072	Low	LTE Band 66 (AWS)	20	24.0	23.85	0.00	0	-	04930	QPSK	50	25	0 mm	bottom	1:1	2.610	1.035	2.701	
1745.00	132322	Mid	LTE Band 66 (AWS)	20	24.0	23.93	0.01	0	-	04930	QPSK	50	25	0 mm	bottom	1:1	2.630	1.016	2.672	
1770.00	132572	High	LTE Band 66 (AWS)	20	24.0	23.96	-0.01	0	-	04930	QPSK	50	25	0 mm	bottom	1:1	2.830	1.009	2.855	
1770.00	132572	High	LTE Band 66 (AWS)	20	24.0	23.91	0.00	0	-	04930	QPSK	100	0	0 mm	bottom	1:1	2.690	1.021	2.746	
1770.00	132572	High	LTE Band 66 (AWS)	20	25.0	25.00	0.19	0	#1	04948	QPSK	1	0	0 mm	back	1:1	2.850	1.000	2.850	
1770.00	132572	High	LTE Band 66 (AWS)	20	25.0	25.00	0.19	0	#1	04948	QPSK	1	0	0 mm	back	1:1	2.850	1.000	2.850	



Note: 1) Blue entry represents variability measurement. 2) Green entries represent additional Phablet SAR Position (DD #1: 0 degrees) 3) Light orange entries represent additional Phablet SAR Position (DD #3: 360 degrees)

FCC ID: ZNFG900VM	 PCTEST Proud to be part of 	SAR EVALUATION REPORT		Approved by: Quality Manager
Document S/N: 1M2006040088-01-R1-ZNF	Test Dates: 06/25/20 – 08/05/20	DUT Type: Portable Handset	Page 118 of 159	

**Table 11-47
LTE Band 2 (PCS) Phablet SAR**

MEASUREMENT RESULTS																				
FREQUENCY		Mode	Bandwidth [MHz]	Maximum Allowed Power [dBm]	Conducted Power [dBm]	Power Drift [dB]	MPR[dB]	Dual Display Accessory Configuration	Serial Number	Modulation	RB Size	RB Offset	Spacing	Side	Duty Cycle	SAR (10g) (W/kg)	Scaling Factor	Reported SAR (10g) (W/kg)	Plot #	
MHz	Ch.																			
1860.00	18700	Low	LTE Band 2 (PCS)	20	25.5	25.06	-0.04	0	-	04914	QPSK	1	99	2 mm	back	1:1	2.190	1.107	2.424	
1880.00	18900	Mid	LTE Band 2 (PCS)	20	25.5	25.19	-0.02	0	-	04914	QPSK	1	99	2 mm	back	1:1	2.210	1.074	2.374	
1900.00	19100	High	LTE Band 2 (PCS)	20	25.5	24.93	0.00	0	-	04914	QPSK	1	99	2 mm	back	1:1	2.150	1.140	2.451	
1860.00	18700	Low	LTE Band 2 (PCS)	20	24.5	24.17	-0.01	1	-	04914	QPSK	50	25	2 mm	back	1:1	1.830	1.079	1.975	
1880.00	18900	Mid	LTE Band 2 (PCS)	20	24.5	24.19	-0.04	1	-	04914	QPSK	50	50	2 mm	back	1:1	1.840	1.074	1.976	
1900.00	19100	High	LTE Band 2 (PCS)	20	24.5	24.18	0.00	1	-	04914	QPSK	50	50	2 mm	back	1:1	1.820	1.076	1.958	
1860.00	18700	Low	LTE Band 2 (PCS)	20	24.5	24.11	-0.03	1	-	04914	QPSK	100	0	2 mm	back	1:1	1.810	1.094	1.980	
1860.00	18700	Low	LTE Band 2 (PCS)	20	25.5	25.06	-0.14	0	-	04914	QPSK	1	99	1 mm	front	1:1	2.470	1.107	2.734	
1880.00	18900	Mid	LTE Band 2 (PCS)	20	25.5	25.19	-0.13	0	-	04914	QPSK	1	99	1 mm	front	1:1	2.450	1.074	2.631	
1900.00	19100	High	LTE Band 2 (PCS)	20	25.5	24.93	-0.13	0	-	04914	QPSK	1	99	1 mm	front	1:1	2.410	1.140	2.747	
1860.00	18700	Low	LTE Band 2 (PCS)	20	24.5	24.17	-0.13	1	-	04914	QPSK	50	25	1 mm	front	1:1	2.060	1.079	2.223	
1880.00	18900	Mid	LTE Band 2 (PCS)	20	24.5	24.19	-0.13	1	-	04914	QPSK	50	50	1 mm	front	1:1	2.040	1.074	2.191	
1900.00	19100	High	LTE Band 2 (PCS)	20	24.5	24.18	-0.13	1	-	04914	QPSK	50	50	1 mm	front	1:1	2.020	1.076	2.174	
1860.00	18700	Low	LTE Band 2 (PCS)	20	24.5	24.11	-0.13	1	-	04914	QPSK	100	0	1 mm	front	1:1	2.050	1.094	2.243	
1860.00	18700	Low	LTE Band 2 (PCS)	20	25.5	25.06	-0.05	0	-	04914	QPSK	1	99	4 mm	bottom	1:1	2.140	1.107	2.369	
1880.00	18900	Mid	LTE Band 2 (PCS)	20	25.5	25.19	-0.05	0	-	04914	QPSK	1	99	4 mm	bottom	1:1	2.230	1.074	2.395	
1900.00	19100	High	LTE Band 2 (PCS)	20	25.5	24.93	-0.04	0	-	04914	QPSK	1	99	4 mm	bottom	1:1	2.260	1.140	2.576	
1860.00	18700	Low	LTE Band 2 (PCS)	20	24.5	24.17	-0.05	1	-	04914	QPSK	50	25	4 mm	bottom	1:1	2.160	1.079	2.331	
1880.00	18900	Mid	LTE Band 2 (PCS)	20	24.5	24.19	-0.03	1	-	04914	QPSK	50	50	4 mm	bottom	1:1	1.870	1.074	2.008	
1900.00	19100	High	LTE Band 2 (PCS)	20	24.5	24.18	-0.03	1	-	04914	QPSK	50	50	4 mm	bottom	1:1	1.910	1.076	2.055	
1860.00	18700	Low	LTE Band 2 (PCS)	20	24.5	24.11	-0.03	1	-	04914	QPSK	100	0	4 mm	bottom	1:1	1.770	1.094	1.936	
1880.00	18900	Mid	LTE Band 2 (PCS)	20	25.5	25.19	-0.10	0	-	04914	QPSK	1	99	0 mm	left	1:1	0.798	1.074	0.857	
1880.00	18900	Mid	LTE Band 2 (PCS)	20	24.5	24.19	-0.07	1	-	04914	QPSK	50	50	0 mm	left	1:1	0.648	1.074	0.696	
1860.00	18700	Low	LTE Band 2 (PCS)	20	25.0	24.99	-0.05	0	#1	04922	QPSK	1	50	0 mm	left	1:1	0.313	1.002	0.314	
1880.00	18900	Mid	LTE Band 2 (PCS)	20	23.0	22.61	-0.14	0	-	04914	QPSK	1	0	0 mm	back	1:1	1.820	1.094	1.991	
1880.00	18900	Mid	LTE Band 2 (PCS)	20	23.0	22.60	-0.02	0	-	04914	QPSK	50	50	0 mm	back	1:1	1.810	1.096	1.984	
1860.00	18700	Low	LTE Band 2 (PCS)	20	25.0	24.99	-0.19	0	#1	04922	QPSK	1	50	0 mm	back	1:1	2.790	1.002	2.796	
1880.00	18900	Mid	LTE Band 2 (PCS)	20	25.0	24.97	-0.09	0	#1	04922	QPSK	1	0	0 mm	back	1:1	2.790	1.007	2.810	
1900.00	19100	High	LTE Band 2 (PCS)	20	25.0	24.97	-0.15	0	#1	04922	QPSK	1	0	0 mm	back	1:1	2.620	1.007	2.638	
1880.00	18900	Mid	LTE Band 2 (PCS)	20	23.0	22.61	-0.13	0	-	04914	QPSK	1	0	0 mm	front	1:1	1.660	1.094	1.816	
1880.00	18900	Mid	LTE Band 2 (PCS)	20	23.0	22.60	-0.14	0	-	04914	QPSK	50	50	0 mm	front	1:1	1.710	1.096	1.874	
1860.00	18700	Low	LTE Band 2 (PCS)	20	25.0	24.99	-0.11	0	#3	04922	QPSK	1	50	0 mm	front	1:1	1.700	1.002	1.703	
1860.00	18700	Low	LTE Band 2 (PCS)	20	23.0	22.24	-0.06	0	-	04914	QPSK	1	99	0 mm	bottom	1:1	2.220	1.191	2.644	
1880.00	18900	Mid	LTE Band 2 (PCS)	20	23.0	22.61	-0.03	0	-	04914	QPSK	1	0	0 mm	bottom	1:1	2.290	1.094	2.505	
1900.00	19100	High	LTE Band 2 (PCS)	20	23.0	22.31	-0.05	0	-	04914	QPSK	1	99	0 mm	bottom	1:1	2.440	1.172	2.860	
1860.00	18700	Low	LTE Band 2 (PCS)	20	23.0	22.32	-0.10	0	-	04914	QPSK	50	25	0 mm	bottom	1:1	2.330	1.169	2.724	
1880.00	18900	Mid	LTE Band 2 (PCS)	20	23.0	22.60	-0.05	0	-	04914	QPSK	50	50	0 mm	bottom	1:1	2.440	1.096	2.674	
1900.00	19100	High	LTE Band 2 (PCS)	20	23.0	22.39	-0.03	0	-	04914	QPSK	50	50	0 mm	bottom	1:1	2.590	1.151	2.981	
1860.00	18700	Low	LTE Band 2 (PCS)	20	23.0	22.32	-0.05	0	-	04914	QPSK	100	0	0 mm	bottom	1:1	2.290	1.169	2.677	
1860.00	18700	Low	LTE Band 2 (PCS)	20	25.0	24.99	-0.09	0	#1	04922	QPSK	1	50	0 mm	bottom	1:1	2.900	1.002	2.906	
1880.00	18900	Mid	LTE Band 2 (PCS)	20	25.0	24.97	-0.09	0	#1	04922	QPSK	1	0	0 mm	bottom	1:1	2.970	1.007	2.991	A51
1900.00	19100	High	LTE Band 2 (PCS)	20	25.0	24.97	-0.05	0	#1	04922	QPSK	1	0	0 mm	bottom	1:1	2.870	1.007	2.890	
1880.00	18900	Mid	LTE Band 2 (PCS)	20	25.0	24.97	-0.09	0	#1	04922	QPSK	1	0	0 mm	bottom	1:1	2.970	1.007	2.991	

Note: 1) Blue entry represents variability measurement. 2) Green entries represent additional Phablet SAR Position (DD #1: 0 degrees) 3) Light orange entries represent additional Phablet SAR Position (DD #3: 360 degrees)

FCC ID: ZNFG900VM	 PCTEST Proud to be part of 	SAR EVALUATION REPORT		Approved by: Quality Manager
Document S/N: 1M2006040088-01-R1.ZNF	Test Dates: 06/25/20 – 08/05/20	DUT Type: Portable Handset	Page 119 of 159	



**Table 11-48
NR Band n66 (AWS) Phablet SAR**

MEASUREMENT RESULTS																				
FREQUENCY		Mode	Bandwidth [MHz]	Maximum Allowed Power [dBm]	Conducted Power [dBm]	Power Drift [dB]	MPR [dB]	Dual Display Accessory Configuration	Serial Number	Modulation	RB Size	RB Offset	Spacing	Side	Duty Cycle	SAR (10g)	Scaling Factor	Reported SAR (10g)	Plot #	
MHz	Ch.															(W/kg)		(W/kg)		
1720.00	344000	Low	NR Band n66 (AWS)	20	24.5	23.76	0.03	0	-	05002	DFT-S-OFDM QPSK	1	104	0 mm	right	1:1	2.390	1.186	2.835	
1745.00	349000	Mid	NR Band n66 (AWS)	20	24.5	23.66	0.04	0	-	05002	DFT-S-OFDM QPSK	1	1	0 mm	right	1:1	2.520	1.213	3.057	
1770.00	354000	High	NR Band n66 (AWS)	20	24.5	23.71	0.06	0	-	05002	DFT-S-OFDM QPSK	1	104	0 mm	right	1:1	2.470	1.199	2.962	
1720.00	344000	Low	NR Band n66 (AWS)	20	24.5	23.75	0.04	0	-	05002	DFT-S-OFDM QPSK	50	28	0 mm	right	1:1	2.460	1.189	2.925	
1745.00	349000	Mid	NR Band n66 (AWS)	20	24.5	23.70	0.09	0	-	05002	DFT-S-OFDM QPSK	50	28	0 mm	right	1:1	2.600	1.202	3.125	
1770.00	354000	High	NR Band n66 (AWS)	20	24.5	23.62	0.04	0	-	05002	DFT-S-OFDM QPSK	50	28	0 mm	right	1:1	2.540	1.225	3.112	
1745.00	349000	Mid	NR Band n66 (AWS)	20	24.5	23.60	0.00	0	-	05002	DFT-S-OFDM QPSK	100	0	0 mm	right	1:1	2.540	1.230	3.124	
1745.00	349000	Mid	NR Band n66 (AWS)	20	24.0	23.15	0.06	0.5	-	05002	CP-OFDM QPSK	1	1	0 mm	right	1:1	2.120	1.216	2.578	
1720.00	344000	Low	NR Band n66 (AWS)	20	25.5	25.01	0.04	0	#1	05002	DFT-S-OFDM QPSK	1	104	0 mm	right	1:1	2.580	1.119	2.887	
1745.00	349000	Mid	NR Band n66 (AWS)	20	25.5	25.01	-0.03	0	#1	05002	DFT-S-OFDM QPSK	1	104	0 mm	right	1:1	2.810	1.119	3.144	A52
1745.00	349000	Mid	NR Band n66 (AWS)	20	25.5	25.01	0.03	0	#3	05002	DFT-S-OFDM QPSK	1	104	0 mm	right	1:1	2.280	1.119	2.551	
1770.00	354000	High	NR Band n66 (AWS)	20	25.5	25.02	-0.11	0	#1	05002	DFT-S-OFDM QPSK	1	104	0 mm	right	1:1	2.580	1.117	2.882	
ANSI / IEEE C95.1 1992 - SAFETY LIMIT Spatial Peak Uncontrolled Exposure/General Population											Phablet 4.0 W/kg (mW/g) averaged over 10 grams									

Note: 1) Green entries represent additional Phablet SAR Position (DD #1: 0 degrees) 2) Light orange entries represent additional Phablet SAR Position (DD #3: 360 degrees)

**Table 11-49
WLAN Phablet SAR**

MEASUREMENT RESULTS																			
FREQUENCY		Mode	Service	Bandwidth [MHz]	Maximum Allowed Power [dBm]	Conducted Power [dBm]	Power Drift [dB]	Spacing	Antenna Config.	Device Serial Number	Data Rate (Mbps)	Side	Duty Cycle (%)	Peak SAR of Area Scan	SAR (10g)	Scaling Factor (Power)	Scaling Factor (Duty Cycle)	Reported SAR (10g)	Plot #
MHz	Ch.													(W/kg)	(W/kg)			(W/kg)	
5280	56	802.11a	OFDM	20	19.0	18.45	-0.05	0 mm	1	04732	6	back	98.3	7.347	0.993	1.135	1.017	1.146	
5280	56	802.11a	OFDM	20	19.0	18.45	0.12	0 mm	1	04732	6	front	98.3	1.700	-	1.135	1.017	-	
5280	56	802.11a	OFDM	20	19.0	18.45	0.15	0 mm	1	04732	6	top	98.3	1.918	-	1.135	1.017	-	
5280	56	802.11a	OFDM	20	19.0	18.45	0.19	0 mm	1	04732	6	left	98.3	2.233	0.246	1.135	1.017	0.284	
5280	56	802.11a	OFDM	20	19.0	18.53	-0.06	0 mm	2	04732	6	back	96.4	5.235	0.412	1.114	1.037	0.476	
5280	56	802.11a	OFDM	20	19.0	18.53	0.10	0 mm	2	04732	6	front	96.4	2.330	-	1.114	1.037	-	
5280	56	802.11a	OFDM	20	19.0	18.53	0.07	0 mm	2	04732	6	top	96.4	2.071	-	1.114	1.037	-	
5280	56	802.11a	OFDM	20	19.0	18.53	-0.12	0 mm	2	04732	6	left	96.4	2.053	-	1.114	1.037	-	
5720	144	802.11a	OFDM	20	17.0	16.75	-0.20	0 mm	1	04732	6	back	98.3	6.174	0.648	1.059	1.017	0.698	
5720	144	802.11a	OFDM	20	17.0	16.75	-0.21	0 mm	1	04732	6	front	98.3	0.225	-	1.059	1.017	-	
5720	144	802.11a	OFDM	20	17.0	16.75	-0.15	0 mm	1	04732	6	top	98.3	0.424	-	1.059	1.017	-	
5720	144	802.11a	OFDM	20	17.0	16.75	-0.11	0 mm	1	04732	6	left	98.3	1.026	-	1.059	1.017	-	
5500	100	802.11a	OFDM	20	17.0	16.68	-0.07	0 mm	2	04732	6	back	96.4	6.843	0.655	1.076	1.037	0.731	
5500	100	802.11a	OFDM	20	17.0	16.68	0.00	0 mm	2	04732	6	front	96.4	2.612	-	1.076	1.037	-	
5500	100	802.11a	OFDM	20	17.0	16.68	0.11	0 mm	2	04732	6	top	96.4	1.937	-	1.076	1.037	-	
5500	100	802.11a	OFDM	20	17.0	16.68	0.12	0 mm	2	04732	6	left	96.4	2.851	-	1.076	1.037	-	
ANSI / IEEE C95.1 1992 - SAFETY LIMIT Spatial Peak Uncontrolled Exposure/General Population											Phablet 4.0 W/kg (mW/g) averaged over 10 grams								

FCC ID: ZNFG900VM		SAR EVALUATION REPORT		Approved by: Quality Manager
Document S/N: 1M2006040088-01-R1.ZNF	Test Dates: 06/25/20 – 08/05/20	DUT Type: Portable Handset		Page 120 of 159

**Table 11-50
WLAN Phablet SAR with 5G NR FR2 Active**



MEASUREMENT RESULTS																			
FREQUENCY		Mode	Service	Bandwidth [MHz]	Maximum Allowed Power [dBm]	Conducted Power [dBm]	Power Drift [dB]	Spacing	Antenna Config.	Device Serial Number	Data Rate (Mbps)	Side	Duty Cycle (%)	Peak SAR of Area Scan [W/kg]	SAR (10g) [W/kg]	Scaling Factor (Power)	Scaling Factor (Duty Cycle)	Reported SAR (10g) [W/kg]	Plot #
MHz	Ch.																		
5270	54	802.11n	OFDM	40	16.0	15.54	0.07	0 mm	1	04732	13.5	back	97.4	2.911	0.536	1.112	1.027	0.612	
5270	54	802.11n	OFDM	40	16.0	15.54	0.00	0 mm	1	04732	13.5	front	97.4	1.004	-	1.112	1.027	-	
5270	54	802.11n	OFDM	40	16.0	15.54	-0.07	0 mm	1	04732	13.5	top	97.4	0.853	-	1.112	1.027	-	
5270	54	802.11n	OFDM	40	16.0	15.54	0.00	0 mm	1	04732	13.5	left	97.4	1.181	-	1.112	1.027	-	
5310	62	802.11n	OFDM	40	16.0	15.59	-0.04	0 mm	2	04732	13.5	back	97.3	3.192	0.269	1.099	1.028	0.304	
5310	62	802.11n	OFDM	40	16.0	15.59	0.19	0 mm	2	04732	13.5	front	97.3	1.232	-	1.099	1.028	-	
5310	62	802.11n	OFDM	40	16.0	15.59	-0.07	0 mm	2	04732	13.5	top	97.3	0.837	-	1.099	1.028	-	
5310	62	802.11n	OFDM	40	16.0	15.59	0.19	0 mm	2	04732	13.5	left	97.3	0.781	-	1.099	1.028	-	
5710	142	802.11n	OFDM	40	16.0	15.92	0.13	0 mm	1	04732	13.5	back	97.4	3.230	0.303	1.019	1.027	0.317	
5710	142	802.11n	OFDM	40	16.0	15.92	0.00	0 mm	1	04732	13.5	front	97.4	0.070	-	1.019	1.027	-	
5710	142	802.11n	OFDM	40	16.0	15.92	0.12	0 mm	1	04732	13.5	top	97.4	0.243	-	1.019	1.027	-	
5710	142	802.11n	OFDM	40	16.0	15.92	0.19	0 mm	1	04732	13.5	left	97.4	0.488	-	1.019	1.027	-	
5510	102	802.11n	OFDM	40	16.0	15.78	-0.09	0 mm	2	04732	13.5	back	97.3	5.935	0.555	1.052	1.028	0.600	
5510	102	802.11n	OFDM	40	16.0	15.78	0.00	0 mm	2	04732	13.5	front	97.3	2.673	-	1.052	1.028	-	
5510	102	802.11n	OFDM	40	16.0	15.78	0.16	0 mm	2	04732	13.5	top	97.3	1.837	-	1.052	1.028	-	
5510	102	802.11n	OFDM	40	16.0	15.78	0.00	0 mm	2	04732	13.5	left	97.3	2.957	-	1.052	1.028	-	
ANSI / IEEE C95.1 1992 - SAFETY LIMIT Spatial Peak Uncontrolled Exposure/General Population										Phablet 4.0 W/kg (mW/g) averaged over 10 grams									

**Table 11-51
WLAN MIMO Phablet SAR**

MEASUREMENT RESULTS																					
FREQUENCY		Mode	Service	Bandwidth [MHz]	Maximum Allowed Power (Ant 1) [dBm]	Conducted Power (Ant 1) [dBm]	Maximum Allowed Power (Ant 2) [dBm]	Conducted Power (Ant 2) [dBm]	Power Drift [dB]	Spacing	Antenna Config.	Device Serial Number	Data Rate (Mbps)	Side	Duty Cycle (%)	Peak SAR of Area Scan [W/kg]	SAR (10g) [W/kg]	Scaling Factor (Power)	Scaling Factor (Duty Cycle)	Reported SAR (10g) [W/kg]	Plot #
MHz	Ch.																				
5280	56	802.11n	OFDM	20	19.0	18.35	19.0	18.47	-0.01	0 mm	MIMO	04732	13	back	98.2	12.402	1.160	1.161	1.018	1.371	
5280	56	802.11n	OFDM	20	19.0	18.35	19.0	18.47	0.16	0 mm	MIMO	04732	13	front	98.2	3.724	0.450	1.161	1.018	0.532	
5280	56	802.11n	OFDM	20	19.0	18.35	19.0	18.47	0.15	0 mm	MIMO	04732	13	top	98.2	2.297	-	1.161	1.018	-	
5280	56	802.11n	OFDM	20	19.0	18.35	19.0	18.47	0.12	0 mm	MIMO	04732	13	left	98.2	3.708	-	1.161	1.018	-	
5720	144	802.11n	OFDM	20	17.0	16.69	17.0	16.44	-0.06	0 mm	MIMO	04732	13	back	98.2	8.207	1.250	1.138	1.018	1.448	A53
5720	144	802.11n	OFDM	20	17.0	16.69	17.0	16.44	0.20	0 mm	MIMO	04732	13	front	98.2	1.367	-	1.138	1.018	-	
5720	144	802.11n	OFDM	20	17.0	16.69	17.0	16.44	0.16	0 mm	MIMO	04732	13	top	98.2	2.034	-	1.138	1.018	-	
5720	144	802.11n	OFDM	20	17.0	16.69	17.0	16.44	0.02	0 mm	MIMO	04732	13	left	98.2	3.613	0.334	1.138	1.018	0.387	
ANSI / IEEE C95.1 1992 - SAFETY LIMIT Spatial Peak Uncontrolled Exposure/General Population										Phablet 4.0 W/kg (mW/g) averaged over 10 grams											

Note:

1. For channel 56 to achieve the 22.0 dBm maximum allowed MIMO power shown in the documentation, each antenna transmits at a maximum allowed power of 19.0 dBm. For channel 144 to achieve the 20.0 dBm maximum allowed MIMO power shown in the documentation, each antenna transmits at a maximum allowed power of 17.0 dBm.

FCC ID: ZNFG900VM	 PCTEST Proud to be part of 	SAR EVALUATION REPORT		Approved by: Quality Manager
Document S/N: 1M2006040088-01-R1.ZNF	Test Dates: 06/25/20 – 08/05/20	DUT Type: Portable Handset	Page 121 of 159	

**Table 11-52
WLAN MIMO Phablet SAR with 5G NR FR2 Active**

MEASUREMENT RESULTS																					
FREQUENCY		Mode	Service	Bandwidth [MHz]	Maximum Allowed Power (Ant 1) [dBm]	Conducted Power (Ant 1) [dBm]	Maximum Allowed Power (Ant 2) [dBm]	Conducted Power (Ant 2) [dBm]	Power Drift [dB]	Spacing	Antenna Config.	Device Serial Number	Data Rate (Mbps)	Side	Duty Cycle (%)	Peak SAR of Area Scan	SAR (10g)	Scaling Factor (Power)	Scaling Factor (Duty Cycle)	Reported SAR (10g)	Plot #
MHz	Ch.															(W/kg)	(W/kg)	(W/kg)			
5270	54	802.11n	OFDM	40	16.0	15.54	16.0	15.44	0.11	0 mm	MMMO	04732	27	back	97.2	6.650	0.622	1.138	1.029	0.728	
5270	54	802.11n	OFDM	40	16.0	15.54	16.0	15.44	0.20	0 mm	MMMO	04732	27	front	97.2	1.953	-	1.138	1.029	-	
5270	54	802.11n	OFDM	40	16.0	15.54	16.0	15.44	0.12	0 mm	MMMO	04732	27	top	97.2	1.087	-	1.138	1.029	-	
5270	54	802.11n	OFDM	40	16.0	15.54	16.0	15.44	0.13	0 mm	MMMO	04732	27	left	97.2	1.974	-	1.138	1.029	-	
5710	142	802.11n	OFDM	40	16.0	15.92	16.0	15.71	-0.07	0 mm	MMMO	04732	27	back	97.2	7.335	0.792	1.069	1.029	0.871	
5710	142	802.11n	OFDM	40	16.0	15.92	16.0	15.71	0.00	0 mm	MMMO	04732	27	front	97.2	1.531	-	1.069	1.029	-	
5710	142	802.11n	OFDM	40	16.0	15.92	16.0	15.71	0.04	0 mm	MMMO	04732	27	top	97.2	1.776	-	1.069	1.029	-	
5710	142	802.11n	OFDM	40	16.0	15.92	16.0	15.71	0.20	0 mm	MMMO	04732	27	left	97.2	2.817	-	1.069	1.029	-	
ANSI / IEEE C95.1 1992 - SAFETY LIMIT Spatial Peak Uncontrolled Exposure/General Population											Phablet 4.0 W/kg (mW/g) averaged over 10 grams										



Note:

1. For channels 54, 142 to achieve the 19.0 dBm maximum allowed MIMO power shown in the documentation, each antenna transmits at a maximum allowed power of 16.0 dBm.

11.5 SAR Test Notes

General Notes:

- The test data reported are the worst-case SAR values according to test procedures specified in IEEE 1528-2013, and FCC KDB Publication 447498 D01v06.
- Batteries are fully charged at the beginning of the SAR measurements.
- Liquid tissue depth was at least 15.0 cm for all frequencies.
- The orange highlights throughout the report represents the highest SAR per FCC Equipment Class reflected on the FCC Grant.
- The manufacturer has confirmed that the device(s) tested have the same physical, mechanical and thermal characteristics and are within operational tolerances expected for production units.
- SAR results were scaled to the maximum allowed power to demonstrate compliance per FCC KDB Publication 447498 D01v06.
- Device was tested using a fixed spacing for body-worn accessory testing. A separation distance of 10 mm was considered because the manufacturer has determined that there will be body-worn accessories available in the marketplace for users to support this separation distance.
- Per FCC KDB Publication 648474 D04v01r03, body-worn SAR was evaluated without a headset connected to the device. Since the standalone reported body-worn SAR was ≤ 1.2 W/kg, no additional body-worn SAR evaluations using a headset cable were required.
- Per FCC KDB 865664 D01v01r04, variability SAR tests were performed when the measured SAR results for a frequency band were greater than or equal to 0.8 W/kg. Repeated SAR measurements are highlighted in the tables above for clarity. Please see Section 13 for variability analysis.
- During SAR Testing for the Wireless Router conditions per FCC KDB Publication 941225 D06v02r01, the actual Portable Hotspot operation (with actual simultaneous transmission of a transmitter with WIFI) was not activated (See Section 6.7 for more details).
- Per FCC KDB Publication 648474 D04v01r03, this device is considered a "phablet" since the diagonal dimension is > 160 mm and < 200 mm. Therefore, phablet SAR tests are required when wireless router mode does not apply or if wireless router 1g SAR > 1.2 W/kg. Additional SAR tests for phablet SAR were evaluated per KDB 616217 Section 6 (See Section 6.9 for more information)
- Unless otherwise noted, when 10g SAR measurement is considered, a factor of 2.5 is applied to the 1g thresholds for the equivalent test cases.
- This device uses Qualcomm Smart Transmit for 2G/3G/4G/5G operations to control and manage transmitting power in real time to ensure RF Exposure compliance. Per FCC Guidance, compliance was assessed at the minimum of the time averaged power and the maximum output power for each band/mode/exposure condition (DSI).
- SAR with the Dual Display Cover was measured for the configurations with the highest SAR reported for each exposure condition. Head SAR tests were performed with the accessory cover folded to 0 and 360

FCC ID: ZNFG900VM	 PCTEST Proud to be part of 	SAR EVALUATION REPORT		Approved by: Quality Manager
Document S/N: 1M2006040088-01-R1.ZNF	Test Dates: 06/25/20 – 08/05/20	DUT Type: Portable Handset	Page 122 of 159	

degrees to represent typical use conditions. Body-worn, Hotspot, and Phablet SAR tests were performed with accessory cover folded to 0, 180 and 360 degrees.

15. When the output power for dual-display cover in a given exposure condition was higher than the power without the dual display cover, additional tests were performed at the higher output power level

GSM Test Notes:

1. Body-Worn accessory testing is typically associated with voice operations. Therefore, GSM voice was evaluated for body-worn SAR.
2. Justification for reduced test configurations per KDB Publication 941225 D01v03r01 and October 2013 TCB Workshop Notes: The source-based frame-averaged output power was evaluated for all GPRS/EDGE slot configurations. The configuration with the highest target frame averaged output power was evaluated for hotspot SAR. When the maximum frame-averaged powers are equivalent across two or more slots (within 0.25 dB), the configuration with the most number of time slots was tested.
3. Per FCC KDB Publication 447498 D01v06, if the reported (scaled) SAR measured at the middle channel or highest output power channel for each test configuration is ≤ 0.8 W/kg for 1g evaluations then testing at the other channels is not required for such test configuration(s). When the maximum output power variation across the required test channels is $> \frac{1}{2}$ dB, instead of the middle channel, the highest output power channel was used.
4. GPRS was additionally evaluated for head and body-worn exposure conditions to address possible VoIP scenarios.

CDMA Notes:



1. Head SAR for CDMA2000 mode was tested under RC3/SO55 per FCC KDB Publication 941225 D01v03r01.
2. Body-Worn SAR was tested with 1x RTT with TDSO / SO32 FCH Only. EVDO Rev0 and RevA and TDSO / SO32 FCH+SCH SAR tests were not required per the 3G SAR Test Reduction Procedure in FCC KDB Publication 941225 D01v03r01.
3. CDMA Wireless Router SAR is measured using Subtype 0/1 Physical Layer configurations for Rev. 0 according to KDB 941225 D01v03r01 procedures for data devices. Wireless Router SAR tests for Subtype 2 of Rev.A and 1x RTT configurations were not required per the 3G SAR Test Reduction Policy in KDB Publication 941225 D01v03r01.
4. Head SAR was additionally evaluated using EVDO Rev. A to determine compliance for VoIP operations.
5. Per FCC KDB Publication 447498 D01v06, if the reported (scaled) SAR measured at the middle channel or highest output power channel for each test configuration is ≤ 0.8 W/kg for 1g evaluations then testing at the other channels is not required for such test configuration(s). When the maximum output power variation across the required test channels is $> \frac{1}{2}$ dB, instead of the middle channel, the highest output power channel was used.

UMTS Notes:

1. UMTS mode was tested under RMC 12.2 kbps with HSPA Inactive per KDB Publication 941225 D01v03r01. AMR and HSPA SAR was not required per the 3G Test Reduction Procedure in KDB Publication 941225 D01v03r01.
2. Per FCC KDB Publication 447498 D01v06, if the reported (scaled) SAR measured at the middle channel or highest output power channel for each test configuration is ≤ 0.8 W/kg for 1g evaluations then testing at the other channels is not required for such test configuration(s). When the maximum output power variation across the required test channels is $> \frac{1}{2}$ dB, instead of the middle channel, the highest output power channel was used.

LTE Notes:

1. LTE test configurations are determined according to SAR Evaluation Considerations for LTE Devices in FCC KDB Publication 941225 D05v02r04. The general test procedures used for testing can be found in Section 8.6.4.

FCC ID: ZNFG900VM	 PCTEST Proud to be part of 	SAR EVALUATION REPORT	 LG	Approved by: Quality Manager
Document S/N: 1M2006040088-01-R1.ZNF	Test Dates: 06/25/20 – 08/05/20	DUT Type: Portable Handset	Page 123 of 159	



2. MPR is permanently implemented for this device by the manufacturer. The specific manufacturer target MPR is indicated alongside the SAR results. MPR is enabled for this device, according to 3GPP TS36.101 Section 6.2.3 – 6.2.5 under Table 6.2.3-1.
3. A-MPR was disabled for all SAR tests by setting NS=01 on the base station simulator. SAR tests were performed with the same number of RB and RB offsets transmitting on all TTI frames (maximum TTI).
4. Per FCC KDB Publication 447498 D01v06, when the reported LTE Band 48 SAR measured at the highest output power channel in a given a test configuration was > 0.6 W/kg for 1g evaluations, testing at the other channels was required for such test configurations.
5. TDD LTE was tested per the guidance provided in FCC KDB Publication 941225 D05v02r04. Testing was performed using UL-DL configuration 0 with 6 UL subframes and 2 S subframes using extended cyclic prefix only and special subframe configuration 6. SAR tests were performed at maximum output power and worst-case transmission duty factor in extended cyclic prefix. Per 3GPP 36.211 Section 4, the duty factor for special subframe configuration 6 using extended cyclic prefix is 0.633.
6. Per KDB Publication 941225 D05Av01r02, SAR for downlink only LTE CA operations was not needed since the maximum average output power in LTE CA mode was not >0.25 dB higher than the maximum output power when downlink carrier aggregation was inactive.
7. For LTE Band 5, per FCC guidance, SAR was first measured with only a single carrier active in the uplink (carrier aggregation not active). For each exposure condition, the uplink CA scenario with two component carriers was additionally tested for the configuration with the highest SAR when carrier aggregation was not active. The SCC was configured with the closest available contiguous channel. The two component carriers were configured so the resource blocks are physically allocated side by side to achieve the maximum output power.

NR Notes:

1. NR implementation is limited to EN-DC operations only. Per FCC guidance, SAR tests for NR Bands and LTE Anchors Bands were performed separately due to limitations in SAR probe calibration factors.
2. Due to test setup limitations, SAR testing for NR was performed using test mode software to establish the connection.
3. Simultaneous transmission analysis for EN-DC operations is addressed in the Part 2 Test Report (Serial Number can be found in the bibliography).
4. This device additionally supports some EN-DC conditions where additional LTE carriers are added on the downlink only.
5. Per FCC Guidance, NR modulations and RB Sizes/Offsets were selected for testing such that configurations with the highest output power were evaluated for SAR tests.
6. Per FCC Guidance, the device was configured with the tuner state selected by the device in LTE mode with auto-tune active at the same frequency as the NR test results. Additional tuner states were evaluated per April 2019 TCBC Workshop Guidance. Please see Section 14 for supplemental data.

WLAN Notes:

1. For held-to-ear, hotspot, and phablet operations, the initial test position procedures were applied. The test position with the highest extrapolated peak SAR will be used as the initial test position. When reported SAR for the initial test position is ≤ 0.4 W/kg for 1g evaluations, no additional testing for the remaining test positions was required. Otherwise, SAR is evaluated at the subsequent highest peak SAR positions until the reported SAR result is ≤ 0.8 W/kg or all test positions are measured.
2. Justification for test configurations for WLAN per KDB Publication 248227 D01v02r02 for 2.4 GHz WIFI single transmission chain operations, the highest measured maximum output power channel for DSSS was selected for SAR measurement. SAR for OFDM modes (2.4 GHz 802.11g/n) was not required due to the maximum allowed powers and the highest reported DSSS SAR. See Section 8.7.5 for more information.
3. Justification for test configurations for WLAN per KDB Publication 248227 D01v02r02 for 5 GHz WIFI single transmission chain operations, the initial test configuration was selected according to the transmission mode with the highest maximum allowed powers. Other transmission modes were not



FCC ID: ZNFG900VM	 PCTEST Proud to be part of 	SAR EVALUATION REPORT	 LG	Approved by: Quality Manager
Document S/N: 1M2006040088-01-R1.ZNF	Test Dates: 06/25/20 – 08/05/20	DUT Type: Portable Handset	Page 124 of 159	

investigated since the highest reported SAR for initial test configuration adjusted by the ratio of maximum output powers is less than 1.2 W/kg for 1g evaluations. See Section 8.7.6 for more information.

4. When the maximum reported 1g averaged SAR is ≤ 0.8 W/kg, SAR testing on additional channels was not required. Otherwise, SAR for the next highest output power channel was required until the reported SAR result was ≤ 1.20 W/kg for 1g evaluations or all test channels were measured.
5. The device was configured to transmit continuously at the required data rate, channel bandwidth and signal modulation, using the highest transmission duty factor supported by the test mode tools. The reported SAR was scaled to the 100% transmission duty factor to determine compliance. Procedures used to measure the duty factor are identical to that in the associated EMC test reports.
6. Per KDB Publication 248227 D01v02r02, SAR for MIMO was evaluated by following the simultaneous SAR provisions from KDB Publication 447498 D01v06 by either evaluating the sum of the 1g SAR values of each antenna transmitting independently or making a SAR measurement with both antennas transmitting simultaneously. Please see Section 12 for complete analysis.

Bluetooth Notes

1. Bluetooth SAR was measured with the device connected to a call box with hopping disabled with DH5 operation and Tx Tests test mode type. Per October 2016 TCB Workshop Notes, the reported SAR was scaled to the 100% transmission duty factor to determine compliance. See Section 9.7 for the time domain plot and calculation for the duty factor of the device.
2. Head and Hotspot Bluetooth SAR were evaluated for BT BR tethering applications.

FCC ID: ZNFG900VM	 PCTEST <small>Proud to be part of element</small>	SAR EVALUATION REPORT		Approved by: Quality Manager
Document S/N: 1M2006040088-01-R1.ZNF	Test Dates: 06/25/20 – 08/05/20	DUT Type: Portable Handset	Page 125 of 159	

12 FCC MULTI-TX AND ANTENNA SAR CONSIDERATIONS

12.1 Introduction

The following procedures adopted from FCC KDB Publication 447498 D01v06 are applicable to devices with built-in unlicensed transmitters such as 802.11 and Bluetooth devices which may simultaneously transmit with the licensed transmitter.

12.2 Simultaneous Transmission Procedures

This device contains transmitters that may operate simultaneously. Therefore, simultaneous transmission analysis is required. Per FCC KDB Publication 447498 D01v06 4.3.2 and IEEE 1528-2013 Section 6.3.4.1.2, simultaneous transmission SAR test exclusion may be applied when the sum of the 1g SAR for all the simultaneous transmitting antennas in a specific physical test configuration is ≤ 1.6 W/kg. The different test positions in an exposure condition may be considered collectively to determine SAR test exclusion according to the sum of 1g or 10g SAR.

Qualcomm Smart Transmit algorithm in WWAN adds directly the time-averaged RF exposure from 4G and time-averaged RF exposure from 5G NR. Smart Transmit algorithm controls the total RF exposure from both 4G and 5G NR to not exceed FCC limit. Therefore, simultaneous transmission compliance between 4G+5G operations is demonstrated in the Qualcomm Part 2 Report during algorithm validation.

Per FCC KDB Publication 941225 D06v02r01, the devices edges with antennas more than 2.5 cm from edge are not required to be evaluated for SAR (“-”).

(*) For test positions that were not required to be evaluated for WLAN SAR per FCC KDB publication 248227, the worst case WLAN SAR result for the applicable exposure conditions was used for simultaneous transmission analysis.

12.3 Head SAR Simultaneous Transmission Analysis

Table 12-1
Simultaneous Transmission Scenario with 2.4 GHz WLAN (Held to Ear)

Exposure Condition	Mode	2G/3G/4G/5G SAR (W/kg)	2.4 GHz WLAN Ant 1 SAR (W/kg)	2.4 GHz WLAN Ant 2 SAR (W/kg)	Σ SAR (W/kg)		
		1	2	3	1+2	1+3	1+2+3
Head SAR	GSM/GPRS 850	0.187	0.309	0.610	0.496	0.797	1.106
	GSM/GPRS 1900	0.063	0.309	0.610	0.372	0.673	0.982
	UMTS 850	0.213	0.309	0.610	0.522	0.823	1.132
	UMTS 1900	0.115	0.309	0.610	0.424	0.725	1.034
	Cell. CDMA/EVDO	0.193	0.309	0.610	0.502	0.803	1.112
	PCS CDMA/EVDO	0.087	0.309	0.610	0.396	0.697	1.006
	LTE Band 12	0.118	0.309	0.610	0.427	0.728	1.037
	LTE Band 13	0.183	0.309	0.610	0.492	0.793	1.102
	LTE Band 5 (Cell)	0.197	0.309	0.610	0.506	0.807	1.116
	LTE Band 66 (AWS)	0.091	0.309	0.610	0.400	0.701	1.010
	LTE Band 2 (PCS)	0.131	0.309	0.610	0.440	0.741	1.050
	LTE Band 48	0.266	0.309	0.610	0.575	0.876	1.185
	NR Band n5 (Cell)	0.142	0.309	0.610	0.451	0.752	1.061
	NR Band n66 (AWS)	0.198	0.309	0.610	0.507	0.808	1.117
NR Band n2 (PCS)	0.093	0.309	0.610	0.402	0.703	1.012	



FCC ID: ZNFG900VM	 PCTEST Proud to be part of 	SAR EVALUATION REPORT		Approved by: Quality Manager
Document S/N: 1M2006040088-01-R1.ZNF	Test Dates: 06/25/20 – 08/05/20	DUT Type: Portable Handset		Page 126 of 159

Table 12-2
Simultaneous Transmission Scenario with 5 GHz WLAN (Held to Ear)

Exposure Condition	Mode	2G/3G/4G/5G SAR (W/kg)	5 GHz WLAN Ant 1 SAR (W/kg)	5 GHz WLAN Ant 2 SAR (W/kg)	Σ SAR (W/kg)		
		1	2	3	1+2	1+3	1+2+3
Head SAR	GSM/GPRS 850	0.187	0.216	0.258	0.403	0.445	0.661
	GSM/GPRS 1900	0.063	0.216	0.258	0.279	0.321	0.537
	UMTS 850	0.213	0.216	0.258	0.429	0.471	0.687
	UMTS 1900	0.115	0.216	0.258	0.331	0.373	0.589
	Cell. CDMA/EVDO	0.193	0.216	0.258	0.409	0.451	0.667
	PCS CDMA/EVDO	0.087	0.216	0.258	0.303	0.345	0.561
	LTE Band 12	0.118	0.216	0.258	0.334	0.376	0.592
	LTE Band 13	0.183	0.216	0.258	0.399	0.441	0.657
	LTE Band 5 (Cell)	0.197	0.216	0.258	0.413	0.455	0.671
	LTE Band 66 (AWS)	0.091	0.216	0.258	0.307	0.349	0.565
	LTE Band 2 (PCS)	0.131	0.216	0.258	0.347	0.389	0.605
	LTE Band 48	0.266	0.216	0.258	0.482	0.524	0.740
	NR Band n5 (Cell)	0.142	0.216	0.258	0.358	0.400	0.616
	NR Band n66 (AWS)	0.198	0.216	0.258	0.414	0.456	0.672
NR Band n2 (PCS)	0.093	0.216	0.258	0.309	0.351	0.567	







FCC ID: ZNFG900VM	 PCTEST Proud to be part of 	SAR EVALUATION REPORT		Approved by: Quality Manager
Document S/N: 1M2006040088-01-R1.ZNF	Test Dates: 06/25/20 – 08/05/20	DUT Type: Portable Handset	Page 127 of 159	

Table 12-3
Simultaneous Transmission Scenario with 2.4 GHz WLAN Ant 1 and 5 GHz WLAN Ant 2 (Held to Ear)

Exposure Condition	Mode	2G/3G/4G/5G SAR (W/kg)	2.4 GHz WLAN Ant 1 SAR (W/kg)	5 GHz WLAN Ant 2 SAR (W/kg)	Σ SAR (W/kg)
		1	2	3	1+2+3
Head SAR	GSM/GPRS 850	0.187	0.309	0.258	0.754
	GSM/GPRS 1900	0.063	0.309	0.258	0.630
	UMTS 850	0.213	0.309	0.258	0.780
	UMTS 1900	0.115	0.309	0.258	0.682
	Cell. CDMA/EVDO	0.193	0.309	0.258	0.760
	PCS CDMA/EVDO	0.087	0.309	0.258	0.654
	LTE Band 12	0.118	0.309	0.258	0.685
	LTE Band 13	0.183	0.309	0.258	0.750
	LTE Band 5 (Cell)	0.197	0.309	0.258	0.764
	LTE Band 66 (AWS)	0.091	0.309	0.258	0.658
	LTE Band 2 (PCS)	0.131	0.309	0.258	0.698
	LTE Band 48	0.266	0.309	0.258	0.833
	NR Band n5 (Cell)	0.142	0.309	0.258	0.709
	NR Band n66 (AWS)	0.198	0.309	0.258	0.765
	NR Band n2 (PCS)	0.093	0.309	0.258	0.660

FCC ID: ZNFG900VM	 PCTEST Proud to be part of 	SAR EVALUATION REPORT		Approved by: Quality Manager
Document S/N: 1M2006040088-01-R1.ZNF	Test Dates: 06/25/20 – 08/05/20	DUT Type: Portable Handset		Page 128 of 159

**Table 12-4
Simultaneous Transmission Scenario with Bluetooth (Held to Ear)**

Exposure Condition	Mode	2G/3G/4G/5G SAR (W/kg)	Bluetooth SAR (W/kg)	Σ SAR (W/kg)
		1	2	1+2
Head SAR	GSM/GPRS 850	0.187	0.075	0.262
	GSM/GPRS 1900	0.063	0.075	0.138
	UMTS 850	0.213	0.075	0.288
	UMTS 1900	0.115	0.075	0.190
	Cell. CDMA/EVDO	0.193	0.075	0.268
	PCS CDMA/EVDO	0.087	0.075	0.162
	LTE Band 12	0.118	0.075	0.193
	LTE Band 13	0.183	0.075	0.258
	LTE Band 5 (Cell)	0.197	0.075	0.272
	LTE Band 66 (AWS)	0.091	0.075	0.166
	LTE Band 2 (PCS)	0.131	0.075	0.206
	LTE Band 48	0.266	0.075	0.341
	NR Band n5 (Cell)	0.142	0.075	0.217
	NR Band n66 (AWS)	0.198	0.075	0.273
NR Band n2 (PCS)	0.093	0.075	0.168	







FCC ID: ZNFG900VM	 PCTEST Proud to be part of 	SAR EVALUATION REPORT		Approved by: Quality Manager
Document S/N: 1M2006040088-01-R1.ZNF	Test Dates: 06/25/20 – 08/05/20	DUT Type: Portable Handset	Page 129 of 159	



Table 12-5
Simultaneous Transmission Scenario with 2.4 GHz WLAN Antenna 2 and Bluetooth (Held to Ear)

Exposure Condition	Mode	2G/3G/4G/5G SAR (W/kg)	Bluetooth SAR (W/kg)	2.4 GHz WLAN Ant 2 SAR (W/kg)	Σ SAR (W/kg)
		1	2	3	1+2+3
Head SAR	GSM/GPRS 850	0.187	0.075	0.610	0.872
	GSM/GPRS 1900	0.063	0.075	0.610	0.748
	UMTS 850	0.213	0.075	0.610	0.898
	UMTS 1900	0.115	0.075	0.610	0.800
	Cell. CDMA/EVDO	0.193	0.075	0.610	0.878
	PCS CDMA/EVDO	0.087	0.075	0.610	0.772
	LTE Band 12	0.118	0.075	0.610	0.803
	LTE Band 13	0.183	0.075	0.610	0.868
	LTE Band 5 (Cell)	0.197	0.075	0.610	0.882
	LTE Band 66 (AWS)	0.091	0.075	0.610	0.776
	LTE Band 2 (PCS)	0.131	0.075	0.610	0.816
	LTE Band 48	0.266	0.075	0.610	0.951
	NR Band n5 (Cell)	0.142	0.075	0.610	0.827
	NR Band n66 (AWS)	0.198	0.075	0.610	0.883
	NR Band n2 (PCS)	0.093	0.075	0.610	0.778

FCC ID: ZNFG900VM	 PCTEST Proud to be part of 	SAR EVALUATION REPORT		Approved by: Quality Manager
Document S/N: 1M2006040088-01-R1.ZNF	Test Dates: 06/25/20 – 08/05/20	DUT Type: Portable Handset		Page 130 of 159

**Table 12-6
Simultaneous Transmission Scenario with 5 GHz WLAN and Bluetooth (Held to Ear)**

Exposure Condition	Mode	2G/3G/4G/5G SAR (W/kg)	Bluetooth SAR (W/kg)	5 GHz WLAN Ant 1 SAR (W/kg)	5 GHz WLAN Ant 2 SAR (W/kg)	Σ SAR (W/kg)
		1	2	3	4	1+2+3+4
Head SAR	GSM/GPRS 850	0.187	0.075	0.216	0.258	0.736
	GSM/GPRS 1900	0.063	0.075	0.216	0.258	0.612
	UMTS 850	0.213	0.075	0.216	0.258	0.762
	UMTS 1900	0.115	0.075	0.216	0.258	0.664
	Cell. CDMA/EVDO	0.193	0.075	0.216	0.258	0.742
	PCS CDMA/EVDO	0.087	0.075	0.216	0.258	0.636
	LTE Band 12	0.118	0.075	0.216	0.258	0.667
	LTE Band 13	0.183	0.075	0.216	0.258	0.732
	LTE Band 5 (Cell)	0.197	0.075	0.216	0.258	0.746
	LTE Band 66 (AWS)	0.091	0.075	0.216	0.258	0.640
	LTE Band 2 (PCS)	0.131	0.075	0.216	0.258	0.680
	LTE Band 48	0.266	0.075	0.216	0.258	0.815
	NR Band n5 (Cell)	0.142	0.075	0.216	0.258	0.691
	NR Band n66 (AWS)	0.198	0.075	0.216	0.258	0.747
NR Band n2 (PCS)	0.093	0.075	0.216	0.258	0.642	

FCC ID: ZNFG900VM	 PCTEST Proud to be part of 	SAR EVALUATION REPORT		Approved by: Quality Manager
Document S/N: 1M2006040088-01-R1.ZNF	Test Dates: 06/25/20 – 08/05/20	DUT Type: Portable Handset	Page 131 of 159	



12.4 Body-Worn Simultaneous Transmission Analysis

Table 12-7
Simultaneous Transmission Scenario with 2.4 GHz WLAN (Body-Worn at 1.0 cm)

Exposure Condition	Mode	2G/3G/4G/5G SAR (W/kg)	2.4 GHz WLAN Ant 1 SAR (W/kg)	2.4 GHz WLAN Ant 2 SAR (W/kg)	Σ SAR (W/kg)			SPLSR		
		1	2	3	1+2	1+3	1+2+3	1+2	1+3	2+3
Body-Worn	GSM/GPRS 850	0.765	0.198	0.336	0.963	1.101	1.299	N/A	N/A	N/A
	GSM/GPRS 1900	0.451	0.198	0.336	0.649	0.787	0.985	N/A	N/A	N/A
	UMTS 850	0.744	0.198	0.336	0.942	1.080	1.278	N/A	N/A	N/A
	UMTS 1900	1.133	0.198	0.336	1.331	1.469	See Note 1	0.01	0.01	0.01
	Cell. CDMA	0.740	0.198	0.336	0.938	1.076	1.274	N/A	N/A	N/A
	PCS CDMA	0.933	0.198	0.336	1.131	1.269	1.467	N/A	N/A	N/A
	LTE Band 12	0.325	0.198	0.336	0.523	0.661	0.859	N/A	N/A	N/A
	LTE Band 13	0.616	0.198	0.336	0.814	0.952	1.150	N/A	N/A	N/A
	LTE Band 5 (Cell)	0.686	0.198	0.336	0.884	1.022	1.220	N/A	N/A	N/A
	LTE Band 66 (AWS)	0.954	0.198	0.336	1.152	1.290	1.488	N/A	N/A	N/A
	LTE Band 2 (PCS)	1.139	0.198	0.336	1.337	1.475	See Note 1	0.01	0.01	0.01
	LTE Band 48	0.202	0.198	0.336	0.400	0.538	0.736	N/A	N/A	N/A
	NR Band n5 (Cell)	0.616	0.198	0.336	0.814	0.952	1.150	N/A	N/A	N/A
	NR Band n66 (AWS)	0.497	0.198	0.336	0.695	0.833	1.031	N/A	N/A	N/A
NR Band n2 (PCS)	0.404	0.198	0.336	0.602	0.740	0.938	N/A	N/A	N/A	

Table 12-8
Simultaneous Transmission Scenario with 5 GHz WLAN (Body-Worn at 1.0 cm)

Exposure Condition	Mode	2G/3G/4G/5G SAR (W/kg)	5 GHz WLAN Ant 1 SAR (W/kg)	5 GHz WLAN Ant 2 SAR (W/kg)	Σ SAR (W/kg)	
		1	2	3	1+2	1+3
Body-Worn	GSM/GPRS 850	0.765	0.336	0.285	1.101	1.050
	GSM/GPRS 1900	0.451	0.336	0.285	0.787	0.736
	UMTS 850	0.744	0.336	0.285	1.080	1.029
	UMTS 1900	1.133	0.336	0.285	1.469	1.418
	Cell. CDMA	0.740	0.336	0.285	1.076	1.025
	PCS CDMA	0.933	0.336	0.285	1.269	1.218
	LTE Band 12	0.325	0.336	0.285	0.661	0.610
	LTE Band 13	0.616	0.336	0.285	0.952	0.901
	LTE Band 5 (Cell)	0.686	0.336	0.285	1.022	0.971
	LTE Band 66 (AWS)	0.954	0.336	0.285	1.290	1.239
	LTE Band 2 (PCS)	1.139	0.336	0.285	1.475	1.424
	LTE Band 48	0.202	0.336	0.285	0.538	0.487
	NR Band n5 (Cell)	0.616	0.336	0.285	0.952	0.901
	NR Band n66 (AWS)	0.497	0.336	0.285	0.833	0.782
NR Band n2 (PCS)	0.404	0.336	0.285	0.740	0.689	

FCC ID: ZNFG900VM	 PCTEST Proud to be part of 	SAR EVALUATION REPORT		Approved by: Quality Manager
Document S/N: 1M2006040088-01-R1.ZNF	Test Dates: 06/25/20 – 08/05/20	DUT Type: Portable Handset		Page 132 of 159

Exposure Condition	Mode	2G/3G/4G/5G SAR (W/kg)	5 GHz WLAN MIMO SAR (W/kg)	Σ SAR (W/kg)	SPLSR
		1	2		
Body-Worn	GSM/GPRS 850	0.765	0.607	1.372	N/A
	GSM/GPRS 1900	0.451	0.607	1.058	N/A
	UMTS 850	0.744	0.607	1.351	N/A
	UMTS 1900	1.133	0.607	See Note 1	0.01
	Cell. CDMA	0.740	0.607	1.347	N/A
	PCS CDMA	0.933	0.607	1.540	N/A
	LTE Band 12	0.325	0.607	0.932	N/A
	LTE Band 13	0.616	0.607	1.223	N/A
	LTE Band 5 (Cell)	0.686	0.607	1.293	N/A
	LTE Band 66 (AWS)	0.954	0.607	1.561	N/A
	LTE Band 2 (PCS)	1.139	0.607	See Note 1	0.02
	LTE Band 48	0.202	0.607	0.809	N/A
	NR Band n5 (Cell)	0.616	0.607	1.223	N/A
	NR Band n66 (AWS)	0.497	0.607	1.104	N/A
	NR Band n2 (PCS)	0.404	0.607	1.011	N/A



FCC ID: ZNFG900VM	 PCTEST Proud to be part of 	SAR EVALUATION REPORT		Approved by: Quality Manager
Document S/N: 1M2006040088-01-R1.ZNF	Test Dates: 06/25/20 – 08/05/20	DUT Type: Portable Handset	Page 133 of 159	

Table 12-9
Simultaneous Transmission Scenario with 2.4 GHz WLAN Ant 1 and 5 GHz WLAN Ant 2
(Body-Worn at 1.0 cm)

Exposure Condition	Mode	2G/3G/4G/5G SAR (W/kg)	2.4 GHz WLAN Ant 1 SAR (W/kg)	5 GHz WLAN Ant 2 SAR (W/kg)	Σ SAR (W/kg)	SPLSR		
		1	2	3	1+2+3	1+2	1+3	2+3
Body-Worn	GSM/GPRS 850	0.765	0.198	0.285	1.248	N/A	N/A	N/A
	GSM/GPRS 1900	0.451	0.198	0.285	0.934	N/A	N/A	N/A
	UMTS 850	0.744	0.198	0.285	1.227	N/A	N/A	N/A
	UMTS 1900	1.133	0.198	0.285	See Note 1	0.01	0.01	0.02
	Cell. CDMA	0.740	0.198	0.285	1.223	N/A	N/A	N/A
	PCS CDMA	0.933	0.198	0.285	1.416	N/A	N/A	N/A
	LTE Band 12	0.325	0.198	0.285	0.808	N/A	N/A	N/A
	LTE Band 13	0.616	0.198	0.285	1.099	N/A	N/A	N/A
	LTE Band 5 (Cell)	0.686	0.198	0.285	1.169	N/A	N/A	N/A
	LTE Band 66 (AWS)	0.954	0.198	0.285	1.437	N/A	N/A	N/A
	LTE Band 2 (PCS)	1.139	0.198	0.285	See Note 1	0.01	0.01	0.02
	LTE Band 48	0.202	0.198	0.285	0.685	N/A	N/A	N/A
	NR Band n5 (Cell)	0.616	0.198	0.285	1.099	N/A	N/A	N/A
NR Band n66 (AWS)	0.497	0.198	0.285	0.980	N/A	N/A	N/A	
NR Band n2 (PCS)	0.404	0.198	0.285	0.887	N/A	N/A	N/A	



FCC ID: ZNFG900VM	 <small>Proud to be part of element</small>	SAR EVALUATION REPORT		Approved by: Quality Manager
Document S/N: 1M2006040088-01-R1.ZNF	Test Dates: 06/25/20 – 08/05/20	DUT Type: Portable Handset	Page 134 of 159	

Table 12-10
Simultaneous Transmission Scenario with Bluetooth (Body-Worn at 1.0 cm)

Exposure Condition	Mode	2G/3G/4G/5G SAR (W/kg)	Bluetooth SAR (W/kg)	Σ SAR (W/kg)
		1	2	1+2
Body-Worn	GSM/GPRS 850	0.765	0.027	0.792
	GSM/GPRS 1900	0.451	0.027	0.478
	UMTS 850	0.744	0.027	0.771
	UMTS 1900	1.133	0.027	1.160
	Cell. CDMA	0.740	0.027	0.767
	PCS CDMA	0.933	0.027	0.960
	LTE Band 12	0.325	0.027	0.352
	LTE Band 13	0.616	0.027	0.643
	LTE Band 5 (Cell)	0.686	0.027	0.713
	LTE Band 66 (AWS)	0.954	0.027	0.981
	LTE Band 2 (PCS)	1.139	0.027	1.166
	LTE Band 48	0.202	0.027	0.229
	NR Band n5 (Cell)	0.616	0.027	0.643
	NR Band n66 (AWS)	0.497	0.027	0.524
	NR Band n2 (PCS)	0.404	0.027	0.431



FCC ID: ZNFG900VM	 PCTEST Proud to be part of 	SAR EVALUATION REPORT		Approved by: Quality Manager
Document S/N: 1M2006040088-01-R1.ZNF	Test Dates: 06/25/20 – 08/05/20	DUT Type: Portable Handset	Page 135 of 159	

Table 12-11
Simultaneous Transmission Scenario with 2.4 GHz WLAN Antenna 2 and Bluetooth (Body-Worn at 1.0 cm)

Exposure Condition	Mode	2G/3G/4G/5G SAR (W/kg)	Bluetooth SAR (W/kg)	2.4 GHz WLAN Ant 2 SAR (W/kg)	Σ SAR (W/kg)
		1	2	3	1+2+3
Body-Worn	GSM/GPRS 850	0.765	0.027	0.336	1.128
	GSM/GPRS 1900	0.451	0.027	0.336	0.814
	UMTS 850	0.744	0.027	0.336	1.107
	UMTS 1900	1.133	0.027	0.336	1.496
	Cell. CDMA	0.740	0.027	0.336	1.103
	PCS CDMA	0.933	0.027	0.336	1.296
	LTE Band 12	0.325	0.027	0.336	0.688
	LTE Band 13	0.616	0.027	0.336	0.979
	LTE Band 5 (Cell)	0.686	0.027	0.336	1.049
	LTE Band 66 (AWS)	0.954	0.027	0.336	1.317
	LTE Band 2 (PCS)	1.139	0.027	0.336	1.502
	LTE Band 48	0.202	0.027	0.336	0.565
	NR Band n5 (Cell)	0.616	0.027	0.336	0.979
	NR Band n66 (AWS)	0.497	0.027	0.336	0.860
	NR Band n2 (PCS)	0.404	0.027	0.336	0.767



FCC ID: ZNFG900VM	 PCTEST Proud to be part of 	SAR EVALUATION REPORT		Approved by: Quality Manager
Document S/N: 1M2006040088-01-R1.ZNF	Test Dates: 06/25/20 – 08/05/20	DUT Type: Portable Handset		Page 136 of 159



Table 12-12
Simultaneous Transmission Scenario with 5 GHz WLAN and Bluetooth (Body-Worn at 1.0 cm)

Exposure Condition	Mode	2G/3G/4G/5G SAR (W/kg)	Bluetooth SAR (W/kg)	5 GHz WLAN Ant 1 SAR (W/kg)	5 GHz WLAN Ant 2 SAR (W/kg)	Σ SAR (W/kg)	
		1	2	3	4	1+2+3	1+2+4
Body-Worn	GSM/GPRS 850	0.765	0.027	0.336	0.285	1.128	1.077
	GSM/GPRS 1900	0.451	0.027	0.336	0.285	0.814	0.763
	UMTS 850	0.744	0.027	0.336	0.285	1.107	1.056
	UMTS 1900	1.133	0.027	0.336	0.285	1.496	1.445
	Cell. CDMA	0.740	0.027	0.336	0.285	1.103	1.052
	PCS CDMA	0.933	0.027	0.336	0.285	1.296	1.245
	LTE Band 12	0.325	0.027	0.336	0.285	0.688	0.637
	LTE Band 13	0.616	0.027	0.336	0.285	0.979	0.928
	LTE Band 5 (Cell)	0.686	0.027	0.336	0.285	1.049	0.998
	LTE Band 66 (AWS)	0.954	0.027	0.336	0.285	1.317	1.266
	LTE Band 2 (PCS)	1.139	0.027	0.336	0.285	1.502	1.451
	LTE Band 48	0.202	0.027	0.336	0.285	0.565	0.514
	NR Band n5 (Cell)	0.616	0.027	0.336	0.285	0.979	0.928
	NR Band n66 (AWS)	0.497	0.027	0.336	0.285	0.860	0.809
NR Band n2 (PCS)	0.404	0.027	0.336	0.285	0.767	0.716	

Exposure Condition	Mode	2G/3G/4G/5G SAR (W/kg)	Bluetooth SAR (W/kg)	5 GHz WLAN MIMO SAR (W/kg)	Σ SAR (W/kg)	SPLSR		
		1	2	3	1+2+3	1+2	1+3	2+3
Body-Worn	GSM/GPRS 850	0.765	0.027	0.607	1.399	N/A	N/A	N/A
	GSM/GPRS 1900	0.451	0.027	0.607	1.085	N/A	N/A	N/A
	UMTS 850	0.744	0.027	0.607	1.378	N/A	N/A	N/A
	UMTS 1900	1.133	0.027	0.607	See Note 1	0.01	0.01	0.02
	Cell. CDMA	0.740	0.027	0.607	1.374	N/A	N/A	N/A
	PCS CDMA	0.933	0.027	0.607	1.567	N/A	N/A	N/A
	LTE Band 12	0.325	0.027	0.607	0.959	N/A	N/A	N/A
	LTE Band 13	0.616	0.027	0.607	1.250	N/A	N/A	N/A
	LTE Band 5 (Cell)	0.686	0.027	0.607	1.320	N/A	N/A	N/A
	LTE Band 66 (AWS)	0.954	0.027	0.607	1.588	N/A	N/A	N/A
	LTE Band 2 (PCS)	1.139	0.027	0.607	See Note 1	0.01	0.02	0.02
	LTE Band 48	0.202	0.027	0.607	0.836	N/A	N/A	N/A
	NR Band n5 (Cell)	0.616	0.027	0.607	1.250	N/A	N/A	N/A
	NR Band n66 (AWS)	0.497	0.027	0.607	1.131	N/A	N/A	N/A
NR Band n2 (PCS)	0.404	0.027	0.607	1.038	N/A	N/A	N/A	

Notes:

1. No evaluation was performed to determine the aggregate 1g SAR for these configurations as the SPLS ratio between the antenna pairs was not greater than 0.04 per FCC KDB 447498 D01v06. See Section 12.7 for detailed SPLS ratio analysis.

FCC ID: ZNFG900VM	 <small>Proud to be part of element</small>	SAR EVALUATION REPORT		Approved by: Quality Manager
Document S/N: 1M2006040088-01-R1.ZNF	Test Dates: 06/25/20 – 08/05/20	DUT Type: Portable Handset	Page 137 of 159	

12.5 Hotspot SAR Simultaneous Transmission Analysis



Table 12-13
Simultaneous Transmission Scenario with 2.4 GHz WLAN (Hotspot at 1.0 cm)

Exposure Condition	Mode	2G/3G/4G/5G SAR (W/kg)	2.4 GHz WLAN Ant 1 SAR (W/kg)	2.4 GHz WLAN Ant 2 SAR (W/kg)	Σ SAR (W/kg)		
		1	2	3	1+2	1+3	1+2+3
Hotspot SAR	GPRS 850	0.765	0.428	0.478	1.193	1.243	See Table Below
	GPRS 1900	0.984	0.428	0.478	1.412	1.462	See Table Below
	UMTS 850	0.744	0.428	0.478	1.172	1.222	See Table Below
	UMTS 1900	1.120	0.428	0.478	1.548	See Table Below	See Table Below
	Cell. EVDO	0.784	0.428	0.478	1.212	1.262	See Table Below
	PCS EVDO	1.010	0.428	0.478	1.438	1.488	See Table Below
	LTE Band 12	0.325	0.428	0.478	0.753	0.803	1.231
	LTE Band 13	0.616	0.428	0.478	1.044	1.094	1.522
	LTE Band 5 (Cell)	0.686	0.428	0.478	1.114	1.164	1.592
	LTE Band 66 (AWS)	0.948	0.428	0.478	1.376	1.426	See Table Below
	LTE Band 2 (PCS)	1.073	0.428	0.478	1.501	1.551	See Table Below
	LTE Band 48	0.202	0.428	0.478	0.630	0.680	1.108
	NR Band n5 (Cell)	0.616	0.428	0.478	1.044	1.094	1.522
NR Band n66 (AWS)	0.995	0.428	0.478	1.423	1.473	See Table Below	
NR Band n2 (PCS)	0.830	0.428	0.478	1.258	1.308	See Table Below	

Simult Tx	Configuration	GPRS 850 SAR (W/kg)	2.4 GHz WLAN Ant 1 SAR (W/kg)	2.4 GHz WLAN Ant 2 SAR (W/kg)	Σ SAR (W/kg)	Simult Tx	Configuration	GPRS 1900 SAR (W/kg)	2.4 GHz WLAN Ant 1 SAR (W/kg)	2.4 GHz WLAN Ant 2 SAR (W/kg)	Σ SAR (W/kg)
		1	2	3	1+2+3			1	2	3	1+2+3
Hotspot SAR	Back	0.765	0.198	0.336	1.299	Hotspot SAR	Back	0.451	0.198	0.336	0.985
	Front	0.487	0.178	0.269	0.934		Front	0.325	0.178	0.269	0.772
	Top	-	0.244	0.478	0.722		Top	-	0.244	0.478	0.722
	Bottom	0.218	-	-	0.218		Bottom	0.984	-	-	0.984
	Right	0.282	-	-	0.282		Left	0.114	0.428	0.478*	1.020
	Left	-	0.428	0.478*	0.906						

Simult Tx	Configuration	UMTS 850 SAR (W/kg)	2.4 GHz WLAN Ant 1 SAR (W/kg)	2.4 GHz WLAN Ant 2 SAR (W/kg)	Σ SAR (W/kg)	Simult Tx	Configuration	UMTS 1900 SAR (W/kg)	2.4 GHz WLAN Ant 1 SAR (W/kg)	2.4 GHz WLAN Ant 2 SAR (W/kg)	Σ SAR (W/kg)	
		1	2	3	1+2+3			1	2	3	1+3	1+2+3
Hotspot SAR	Back	0.744	0.198	0.336	1.278	Hotspot SAR	Back	0.714	0.198	0.336	1.050	1.248
	Front	0.626	0.178	0.269	1.073		Front	0.678	0.178	0.269	0.947	1.125
	Top	-	0.244	0.478	0.722		Top	-	0.244	0.478	0.478	0.722
	Bottom	0.343	-	-	0.343		Bottom	1.120	-	-	1.120	1.120
	Right	0.401	-	-	0.401		Left	0.173	0.428	0.478*	0.651	1.079
	Left	-	0.428	0.478*	0.906							

Simult Tx	Configuration	Cell. EVDO SAR (W/kg)	2.4 GHz WLAN Ant 1 SAR (W/kg)	2.4 GHz WLAN Ant 2 SAR (W/kg)	Σ SAR (W/kg)	Simult Tx	Configuration	PCS EVDO SAR (W/kg)	2.4 GHz WLAN Ant 1 SAR (W/kg)	2.4 GHz WLAN Ant 2 SAR (W/kg)	Σ SAR (W/kg)
		1	2	3	1+2+3			1	2	3	1+2+3
Hotspot SAR	Back	0.784	0.198	0.336	1.318	Hotspot SAR	Back	0.671	0.198	0.336	1.205
	Front	0.745	0.178	0.269	1.192		Front	0.677	0.178	0.269	1.124
	Top	-	0.244	0.478	0.722		Top	-	0.244	0.478	0.722
	Bottom	0.344	-	-	0.344		Bottom	1.010	-	-	1.010
	Right	0.388	-	-	0.388		Left	0.138	0.428	0.478*	1.044
	Left	-	0.428	0.478*	0.906						



FCC ID: ZNFG900VM	 PCTEST Proud to be part of 	SAR EVALUATION REPORT		Approved by: Quality Manager
Document S/N: 1M2006040088-01-R1.ZNF	Test Dates: 06/25/20 – 08/05/20	DUT Type: Portable Handset		Page 138 of 159

Simult Tx	Configuration	LTE Band 66 (AWS) SAR (W/kg)	2.4 GHz WLAN Ant 1 SAR (W/kg)	2.4 GHz WLAN Ant 2 SAR (W/kg)	Σ SAR (W/kg)	Simult Tx	Configuration	LTE Band 2 (PCS) SAR (W/kg)	2.4 GHz WLAN Ant 1 SAR (W/kg)	2.4 GHz WLAN Ant 2 SAR (W/kg)	Σ SAR (W/kg)
		1	2	3	1+2+3			1	2	3	1+2+3
Hotspot SAR	Back	0.787	0.198	0.336	1.321	Hotspot SAR	Back	0.696	0.198	0.336	1.230
	Front	0.802	0.178	0.269	1.249		Front	0.781	0.178	0.269	1.228
	Top	-	0.244	0.478	0.722		Top	-	0.244	0.478	0.722
	Bottom	0.948	-	-	0.948		Bottom	1.073	-	-	1.073
	Left	0.206	0.428	0.478*	1.112		Left	0.189	0.428	0.478*	1.095

Simult Tx	Configuration	NR Band n66 (AWS)	2.4 GHz WLAN Ant 1 SAR (W/kg)	2.4 GHz WLAN Ant 2 SAR (W/kg)	Σ SAR (W/kg)	Simult Tx	Configuration	NR Band n2 (PCS)	2.4 GHz WLAN Ant 1 SAR (W/kg)	2.4 GHz WLAN Ant 2 SAR (W/kg)	Σ SAR (W/kg)
		1	2	3	1+2+3			1	2	3	1+2+3
Hotspot SAR	Back	0.497	0.198	0.336	1.031	Hotspot SAR	Back	0.404	0.198	0.336	0.938
	Front	0.349	0.178	0.269	0.796		Front	0.352	0.178	0.269	0.799
	Top	-	0.244	0.478	0.722		Top	-	0.244	0.478	0.722
	Right	0.995	-	-	0.995		Right	0.830	-	-	0.830
	Left	-	0.428	0.478*	0.906		Left	-	0.428	0.478*	0.906

Table 12-14
Simultaneous Transmission Scenario with 5 GHz WLAN (Hotspot at 1.0 cm)

Exposure Condition	Mode	2G/3G/4G/5G SAR (W/kg)	5 GHz WLAN Ant 1 SAR (W/kg)	5 GHz WLAN Ant 2 SAR (W/kg)	Σ SAR (W/kg)		
		1	2	3	1+2	1+3	1+2+3
Hotspot SAR	GPRS 850	0.765	0.493	0.267	1.258	1.032	1.525
	GPRS 1900	0.984	0.493	0.267	1.477	1.251	See Table Below
	UMTS 850	0.744	0.493	0.267	1.237	1.011	1.504
	UMTS 1900	1.120	0.493	0.267	See Table Below	1.387	See Table Below
	Cell. EVDO	0.784	0.493	0.267	1.277	1.051	1.544
	PCS EVDO	1.010	0.493	0.267	1.503	1.277	See Table Below
	LTE Band 12	0.325	0.493	0.267	0.818	0.592	1.085
	LTE Band 13	0.616	0.493	0.267	1.109	0.883	1.376
	LTE Band 5 (Cell)	0.686	0.493	0.267	1.179	0.953	1.446
	LTE Band 66 (AWS)	0.948	0.493	0.267	1.441	1.215	See Table Below
	LTE Band 2 (PCS)	1.073	0.493	0.267	1.566	1.340	See Table Below
	LTE Band 48	0.202	0.493	0.267	0.695	0.469	0.962
	NR Band n5 (Cell)	0.616	0.493	0.267	1.109	0.883	1.376
	NR Band n66 (AWS)	0.995	0.493	0.267	1.488	1.262	See Table Below
	NR Band n2 (PCS)	0.830	0.493	0.267	1.323	1.097	1.590

FCC ID: ZNFG900VM	 PCTEST Proud to be part of 	SAR EVALUATION REPORT		Approved by: Quality Manager
Document S/N: 1M2006040088-01-R1.ZNF	Test Dates: 06/25/20 – 08/05/20	DUT Type: Portable Handset	Page 139 of 159	

Simult Tx	Configuration	GPRS 1900 SAR (W/kg)	5 GHz WLAN Ant 1 SAR (W/kg)	5 GHz WLAN Ant 2 SAR (W/kg)	Σ SAR (W/kg)
		1	2	3	1+2+3
Hotspot SAR	Back	0.451	0.493	0.267	1.211
	Front	0.325	0.493*	0.267*	1.085
	Top	-	0.273	0.267*	0.540
	Bottom	0.984	-	-	0.984
	Left	0.114	0.493*	0.267*	0.874

Simult Tx	Configuration	UMTS 1900 SAR (W/kg)	5 GHz WLAN Ant 1 SAR (W/kg)	5 GHz WLAN Ant 2 SAR (W/kg)	Σ SAR (W/kg)		Simult Tx	Configuration	PCS EVDO SAR (W/kg)	5 GHz WLAN Ant 1 SAR (W/kg)	5 GHz WLAN Ant 2 SAR (W/kg)	Σ SAR (W/kg)
		1	2	3	1+2	1+2+3			1	2	3	1+2+3
Hotspot SAR	Back	0.714	0.493	0.267	1.207	1.474	Hotspot SAR	Back	0.671	0.493	0.267	1.431
	Front	0.678	0.493*	0.267*	1.171	1.438		Front	0.677	0.493*	0.267*	1.437
	Top	-	0.273	0.267*	0.273	0.540		Top	-	0.273	0.267*	0.540
	Bottom	1.120	-	-	1.120	1.120		Bottom	1.010	-	-	1.010
	Left	0.173	0.493*	0.267*	0.666	0.933		Left	0.138	0.493*	0.267*	0.898

Simult Tx	Configuration	LTE Band 66 (AWS) SAR (W/kg)	5 GHz WLAN Ant 1 SAR (W/kg)	5 GHz WLAN Ant 2 SAR (W/kg)	Σ SAR (W/kg)	Simult Tx	Configuration	LTE Band 2 (PCS) SAR (W/kg)	5 GHz WLAN Ant 1 SAR (W/kg)	5 GHz WLAN Ant 2 SAR (W/kg)	Σ SAR (W/kg)
		1	2	3	1+2+3			1	2	3	1+2+3
Hotspot SAR	Back	0.787	0.493	0.267	1.547	Hotspot SAR	Back	0.696	0.493	0.267	1.456
	Front	0.802	0.493*	0.267*	1.562		Front	0.781	0.493*	0.267*	1.541
	Top	-	0.273	0.267*	0.540		Top	-	0.273	0.267*	0.540
	Bottom	0.948	-	-	0.948		Bottom	1.073	-	-	1.073
	Left	0.206	0.493*	0.267*	0.966		Left	0.189	0.493*	0.267*	0.949

Simult Tx	Configuration	NR Band n66 (AWS)	5 GHz WLAN Ant 1 SAR (W/kg)	5 GHz WLAN Ant 2 SAR (W/kg)	Σ SAR (W/kg)
		1	2	3	1+2+3
Hotspot SAR	Back	0.497	0.493	0.267	1.257
	Front	0.349	0.493*	0.267*	1.109
	Top	-	0.273	0.267*	0.540
	Right	0.995	-	-	0.995
	Left	-	0.493*	0.267*	0.760



FCC ID: ZNFG900VM	 PCTEST Proud to be part of 	SAR EVALUATION REPORT		Approved by: Quality Manager
Document S/N: 1M2006040088-01-R1.ZNF	Test Dates: 06/25/20 – 08/05/20	DUT Type: Portable Handset	Page 140 of 159	

Table 12-15
Simultaneous Transmission Scenario with 2.4 GHz WLAN Ant 1 and 5 GHz WLAN Ant 2
(Hotspot at 1.0 cm)

Exposure Condition	Mode	2G/3G/4G/5G SAR (W/kg)	2.4 GHz WLAN Ant 1 SAR (W/kg)	5 GHz WLAN Ant 2 SAR (W/kg)	Σ SAR (W/kg)
		1	2	3	1+2+3
Hotspot SAR	GPRS 850	0.765	0.428	0.267	1.460
	GPRS 1900	0.984	0.428	0.267	See Table Below
	UMTS 850	0.744	0.428	0.267	1.439
	UMTS 1900	1.120	0.428	0.267	See Table Below
	Cell. EVDO	0.784	0.428	0.267	1.479
	PCS EVDO	1.010	0.428	0.267	See Table Below
	LTE Band 12	0.325	0.428	0.267	1.020
	LTE Band 13	0.616	0.428	0.267	1.311
	LTE Band 5 (Cell)	0.686	0.428	0.267	1.381
	LTE Band 66 (AWS)	0.948	0.428	0.267	See Table Below
	LTE Band 2 (PCS)	1.073	0.428	0.267	See Table Below
	LTE Band 48	0.202	0.428	0.267	0.897
	NR Band n5 (Cell)	0.616	0.428	0.267	1.311
	NR Band n66 (AWS)	0.995	0.428	0.267	See Table Below
NR Band n2 (PCS)	0.830	0.428	0.267	1.525	

Simult Tx	Configuration	GPRS 1900 SAR (W/kg)	2.4 GHz WLAN Ant 1 SAR (W/kg)	5 GHz WLAN Ant 2 SAR (W/kg)	Σ SAR (W/kg)	Simult Tx	Configuration	UMTS 1900 SAR (W/kg)	2.4 GHz WLAN Ant 1 SAR (W/kg)	5 GHz WLAN Ant 2 SAR (W/kg)	Σ SAR (W/kg)
		1	2	3	1+2+3			1	2	3	1+2+3
Hotspot SAR	Back	0.451	0.198	0.267	0.916	Hotspot SAR	Back	0.714	0.198	0.267	1.179
	Front	0.325	0.178	0.267*	0.770		Front	0.678	0.178	0.267*	1.123
	Top	-	0.244	0.267*	0.511		Top	-	0.244	0.267*	0.511
	Bottom	0.984	-	-	0.984		Bottom	1.120	-	-	1.120
	Left	0.114	0.428	0.267*	0.809		Left	0.173	0.428	0.267*	0.868
Hotspot SAR	Back	0.671	0.198	0.267	1.136	Hotspot SAR	Back	0.787	0.198	0.267	1.252
	Front	0.677	0.178	0.267*	1.122		Front	0.802	0.178	0.267*	1.247
	Top	-	0.244	0.267*	0.511		Top	-	0.244	0.267*	0.511
	Bottom	1.010	-	-	1.010		Bottom	0.948	-	-	0.948
	Left	0.138	0.428	0.267*	0.833		Left	0.206	0.428	0.267*	0.901
Hotspot SAR	Back	0.696	0.198	0.267	1.161	Hotspot SAR	Back	0.497	0.198	0.267	0.962
	Front	0.781	0.178	0.267*	1.226		Front	0.349	0.178	0.267*	0.794
	Top	-	0.244	0.267*	0.511		Top	-	0.244	0.267*	0.511
	Bottom	1.073	-	-	1.073		Bottom	0.995	-	-	0.995
	Left	0.189	0.428	0.267*	0.884		Left	-	0.428	0.267*	0.695



FCC ID: ZNFG900VM	 <small>Proud to be part of element</small>	SAR EVALUATION REPORT		Approved by: Quality Manager
Document S/N: 1M2006040088-01-R1.ZNF	Test Dates: 06/25/20 – 08/05/20	DUT Type: Portable Handset		Page 141 of 159

Table 12-16
Simultaneous Transmission Scenario with Bluetooth (Hotspot at 1.0 cm)

Exposure Condition	Mode	2G/3G/4G/5G SAR (W/kg)	Bluetooth SAR (W/kg)	Σ SAR (W/kg)
		1	2	1+2
Hotspot SAR	GPRS 850	0.765	0.057	0.822
	GPRS 1900	0.984	0.057	1.041
	UMTS 850	0.744	0.057	0.801
	UMTS 1900	1.120	0.057	1.177
	Cell. EVDO	0.784	0.057	0.841
	PCS EVDO	1.010	0.057	1.067
	LTE Band 12	0.325	0.057	0.382
	LTE Band 13	0.616	0.057	0.673
	LTE Band 5 (Cell)	0.686	0.057	0.743
	LTE Band 66 (AWS)	0.948	0.057	1.005
	LTE Band 2 (PCS)	1.073	0.057	1.130
	LTE Band 48	0.202	0.057	0.259
	NR Band n5 (Cell)	0.616	0.057	0.673
	NR Band n66 (AWS)	0.995	0.057	1.052
NR Band n2 (PCS)	0.830	0.057	0.887	



FCC ID: ZNFG900VM	 PCTEST Proud to be part of 	SAR EVALUATION REPORT		Approved by: Quality Manager
Document S/N: 1M2006040088-01-R1.ZNF	Test Dates: 06/25/20 – 08/05/20	DUT Type: Portable Handset	Page 142 of 159	

Table 12-17

Simultaneous Transmission Scenario with 2.4 GHz WLAN Antenna 2 and Bluetooth (Hotspot at 1.0 cm)

Exposure Condition	Mode	2G/3G/4G/5G SAR (W/kg)	Bluetooth SAR (W/kg)	2.4 GHz WLAN Ant 2 SAR (W/kg)	Σ SAR (W/kg)
		1	2	3	
Hotspot SAR	GPRS 850	0.765	0.057	0.478	1.300
	GPRS 1900	0.984	0.057	0.478	1.519
	UMTS 850	0.744	0.057	0.478	1.279
	UMTS 1900	1.120	0.057	0.478	See Table Below
	Cell. EVDO	0.784	0.057	0.478	1.319
	PCS EVDO	1.010	0.057	0.478	1.545
	LTE Band 12	0.325	0.057	0.478	0.860
	LTE Band 13	0.616	0.057	0.478	1.151
	LTE Band 5 (Cell)	0.686	0.057	0.478	1.221
	LTE Band 66 (AWS)	0.948	0.057	0.478	1.483
	LTE Band 2 (PCS)	1.073	0.057	0.478	See Table Below
	LTE Band 48	0.202	0.057	0.478	0.737
	NR Band n5 (Cell)	0.616	0.057	0.478	1.151
	NR Band n66 (AWS)	0.995	0.057	0.478	1.530
	NR Band n2 (PCS)	0.830	0.057	0.478	1.365

Simult Tx	Configuration	UMTS 1900 SAR (W/kg)	Bluetooth SAR (W/kg)	2.4 GHz WLAN Ant 2 SAR (W/kg)	Σ SAR (W/kg)	Simult Tx	Configuration	LTE Band 2 (PCS) SAR (W/kg)	Bluetooth SAR (W/kg)	2.4 GHz WLAN Ant 2 SAR (W/kg)	Σ SAR (W/kg)
		1	2	3	1+2+3			1	2	3	1+2+3
Hotspot SAR	Back	0.714	0.027	0.336	1.077	Hotspot SAR	Back	0.696	0.027	0.336	1.059
	Front	0.678	0.020	0.269	0.967		Front	0.781	0.020	0.269	1.070
	Top	-	0.028	0.478	0.506		Top	-	0.028	0.478	0.506
	Bottom	1.120	-	-	1.120		Bottom	1.073	-	-	1.073
	Left	0.173	0.057	0.478*	0.708		Left	0.189	0.057	0.478*	0.724







FCC ID: ZNFG900VM	 PCTEST Proud to be part of 	SAR EVALUATION REPORT		Approved by: Quality Manager
Document S/N: 1M2006040088-01-R1.ZNF	Test Dates: 06/25/20 – 08/05/20	DUT Type: Portable Handset		Page 143 of 159

Table 12-18
Simultaneous Transmission Scenario with 5 GHz WLAN and Bluetooth (Hotspot at 1.0 cm)

Exposure Condition	Mode	2G/3G/4G/5G SAR (W/kg)	Bluetooth SAR (W/kg)	5 GHz WLAN Ant 1 SAR (W/kg)	5 GHz WLAN Ant 2 SAR (W/kg)	Σ SAR (W/kg)
		1	2	3	4	1+2+3+4
Hotspot SAR	GPRS 850	0.765	0.057	0.493	0.267	1.582
	GPRS 1900	0.984	0.057	0.493	0.267	See Table Below
	UMTS 850	0.744	0.057	0.493	0.267	1.561
	UMTS 1900	1.120	0.057	0.493	0.267	See Table Below
	Cell. EVDO	0.784	0.057	0.493	0.267	See Table Below
	PCS EVDO	1.010	0.057	0.493	0.267	See Table Below
	LTE Band 12	0.325	0.057	0.493	0.267	1.142
	LTE Band 13	0.616	0.057	0.493	0.267	1.433
	LTE Band 5 (Cell)	0.686	0.057	0.493	0.267	1.503
	LTE Band 66 (AWS)	0.948	0.057	0.493	0.267	See Table Below
	LTE Band 2 (PCS)	1.073	0.057	0.493	0.267	See Table Below
	LTE Band 48	0.202	0.057	0.493	0.267	1.019
	NR Band n5 (Cell)	0.616	0.057	0.493	0.267	1.433
	NR Band n66 (AWS)	0.995	0.057	0.493	0.267	See Table Below
NR Band n2 (PCS)	0.830	0.057	0.493	0.267	See Table Below	

Simult Tx	Configuration	GPRS 1900 SAR (W/kg)	Bluetooth SAR (W/kg)	5 GHz WLAN Ant 1 SAR (W/kg)	5 GHz WLAN Ant 2 SAR (W/kg)	Σ SAR (W/kg)	Simult Tx	Configuration	UMTS 1900 SAR (W/kg)	Bluetooth SAR (W/kg)	5 GHz WLAN Ant 1 SAR (W/kg)	5 GHz WLAN Ant 2 SAR (W/kg)	Σ SAR (W/kg)	
		1	2	3	4	1+2+3+4			1	2	3	4	1+2+3+4	
Hotspot SAR	Back	0.451	0.027	0.493	0.267	1.238	Hotspot SAR	Back	0.714	0.027	0.493	0.267	1.501	
	Front	0.325	0.020	0.493*	0.267*	1.105		Front	0.678	0.020	0.493*	0.267*	1.458	
	Top	-	0.028	0.273	0.267*	0.568		Top	-	0.028	0.273	0.267*	0.568	
	Bottom	0.984	-	-	-	0.984		Bottom	1.120	-	-	-	-	1.120
	Left	0.114	0.057	0.493*	0.267*	0.931		Left	0.173	0.057	0.493*	0.267*	0.990	
Hotspot SAR	Back	0.784	0.027	0.493	0.267	1.571	Hotspot SAR	Back	0.671	0.027	0.493	0.267	1.458	
	Front	0.745	0.020	0.493*	0.267*	1.525		Front	0.677	0.020	0.493*	0.267*	1.457	
	Top	-	0.028	0.273	0.267*	0.568		Top	-	0.028	0.273	0.267*	0.568	
	Bottom	0.344	-	-	-	0.344		Bottom	1.010	-	-	-	-	1.010
	Left	0.388	0.057	0.493*	0.267*	0.817		Left	0.138	0.057	0.493*	0.267*	0.955	
Hotspot SAR	Back	0.787	0.027	0.493	0.267	1.574	Hotspot SAR	Back	0.696	0.027	0.493	0.267	1.483	
	Front	0.802	0.020	0.493*	0.267*	1.582		Front	0.781	0.020	0.493*	0.267*	1.561	
	Top	-	0.028	0.273	0.267*	0.568		Top	-	0.028	0.273	0.267*	0.568	
	Bottom	0.948	-	-	-	0.948		Bottom	1.073	-	-	-	-	1.073
	Left	0.206	0.057	0.493*	0.267*	1.023		Left	0.189	0.057	0.493*	0.267*	1.006	

FCC ID: ZNFG900VM	 PCTEST Proud to be part of 	SAR EVALUATION REPORT		Approved by: Quality Manager
Document S/N: 1M2006040088-01-R1.ZNF	Test Dates: 06/25/20 – 08/05/20	DUT Type: Portable Handset	Page 144 of 159	

Simult Tx	Configuration	NR Band n66 (AWS)	Bluetooth SAR (W/kg)	5 GHz WLAN Ant 1 SAR (W/kg)	5 GHz WLAN Ant 2 SAR (W/kg)	Σ SAR (W/kg)
		1	2	3	4	1+2+3+4
Hotspot SAR	Back	0.497	0.027	0.493	0.267	1.284
	Front	0.349	0.020	0.493*	0.267*	1.129
	Top	-	0.028	0.273	0.267*	0.568
	Right	0.995	-	-	-	0.995
	Left	-	0.057	0.493*	0.267*	0.817

12.6 Phablet Simultaneous Transmission Analysis

Per FCC KDB Publication 648474 D04 Handset SAR, Phablet SAR tests were not required if wireless router 1g SAR (scaled to the maximum output power, including tolerance) < 1.2 W/kg. Therefore, no further analysis beyond the tables included in this section was required to determine that possible simultaneous transmission scenarios would not exceed the SAR limit.

For SAR summation, the highest reported SAR across all test distances was used as the most conservative evaluation for simultaneous transmission analysis for each device edge.

Table 12-19
Simultaneous Transmission Scenario with 5 GHz WLAN (Phablet)



Simult Tx	Configuration	UMTS 1900 SAR (W/kg)	5 GHz WLAN Ant 1 SAR (W/kg)	5 GHz WLAN Ant 2 SAR (W/kg)	Σ SAR (W/kg)		SPLSR
		1	2	3	1+2	1+3	1+2
Phablet SAR	Back	2.916	1.146	0.731	See Note 1	3.647	0.05
	Front	2.404	1.146*	0.731*	3.550	3.135	N/A
	Top	-	1.146*	0.731*	1.146	0.731	N/A
	Bottom	3.029	-	-	3.029	3.029	N/A
	Right	0.929	0.284	0.731*	1.213	1.660	N/A
	Left						

Simult Tx	Configuration	LTE Band 66 (AWS) SAR (W/kg)	5 GHz WLAN Ant 1 SAR (W/kg)	5 GHz WLAN Ant 2 SAR (W/kg)	Σ SAR (W/kg)		SPLSR
		1	2	3	1+2	1+3	1+2
Phablet SAR	Back	2.850	1.146	0.731	See Note 1	3.581	0.05
	Front	2.346	1.146*	0.731*	3.492	3.077	N/A
	Top	-	1.146*	0.731*	1.146	0.731	N/A
	Bottom	2.855	-	-	2.855	2.855	N/A
	Right	0.780	0.284	0.731*	1.064	1.511	N/A
	Left						

Simult Tx	Configuration	PCS EVDO SAR (W/kg)	5 GHz WLAN Ant 1 SAR (W/kg)	5 GHz WLAN Ant 2 SAR (W/kg)	Σ SAR (W/kg)	
		1	2	3	1+2	1+3
Phablet SAR	Back	2.793	1.146	0.731	3.939	3.524
	Front	1.981	1.146*	0.731*	3.127	2.712
	Top	-	1.146*	0.731*	1.146	0.731
	Bottom	2.854	-	-	2.854	2.854
	Right	0.706	0.284	0.731*	0.990	1.437
	Left					

Simult Tx	Configuration	LTE Band 2 (PCS) SAR (W/kg)	5 GHz WLAN Ant 1 SAR (W/kg)	5 GHz WLAN Ant 2 SAR (W/kg)	Σ SAR (W/kg)	
		1	2	3	1+2	1+3
Phablet SAR	Back	2.810	1.146	0.731	3.956	3.541
	Front	2.747	1.146*	0.731*	3.893	3.478
	Top	-	1.146*	0.731*	1.146	0.731
	Bottom	2.991	-	-	2.991	2.991
	Right	0.857	0.284	0.731*	1.141	1.588
	Left					

Simult Tx	Configuration	NR Band n66 (AWS)	5 GHz WLAN Ant 1 SAR (W/kg)	5 GHz WLAN Ant 2 SAR (W/kg)	Σ SAR (W/kg)	
		1	2	3	1+2	1+3
Phablet SAR	Back	-	1.146	0.731	1.146	0.731
	Front	-	1.146*	0.731*	1.146	0.731
	Top	-	1.146*	0.731*	1.146	0.731
	Right	3.144	-	-	3.144	3.144
	Left	-	0.284	0.731*	0.284	0.731

FCC ID: ZNFG900VM	 PCTEST Proud to be part of 	SAR EVALUATION REPORT		Approved by: Quality Manager
Document S/N: 1M2006040088-01-R1.ZNF	Test Dates: 06/25/20 – 08/05/20	DUT Type: Portable Handset		Page 145 of 159

Simult Tx	Configuration	UMTS 1900 SAR (W/kg)	5 GHz WLAN MIMO SAR (W/kg)	Σ SAR (W/kg)	SPLSR	Simult Tx	Configuration	PCS EVDO SAR (W/kg)	5 GHz WLAN MIMO SAR (W/kg)	Σ SAR (W/kg)	SPLSR
		1	2	1+2	1+2			1	2	1+2	1+2
Phablet SAR	Back	2.916	1.448	See Note 1	0.06	Phablet SAR	Back	2.793	1.448	See Note 1	0.06
	Front	2.404	0.532	2.936	N/A		Front	1.981	0.532	2.513	N/A
	Top	-	1.448*	1.448	N/A		Top	-	1.448*	1.448	N/A
	Bottom	3.029	-	3.029	N/A		Bottom	2.854	-	2.854	N/A
	Left	0.929	0.387	1.316	N/A		Left	0.706	0.387	1.093	N/A
Simult Tx	Configuration	LTE Band 66 (AWS) SAR (W/kg)	5 GHz WLAN MIMO SAR (W/kg)	Σ SAR (W/kg)	SPLSR	Simult Tx	Configuration	LTE Band 2 (PCS) SAR (W/kg)	5 GHz WLAN MIMO SAR (W/kg)	Σ SAR (W/kg)	SPLSR
		1	2	1+2	1+2			1	2	1+2	1+2
Phablet SAR	Back	2.850	1.448	See Note 1	0.06	Phablet SAR	Back	2.810	1.448	See Note 1	0.06
	Front	2.346	0.532	2.878	N/A		Front	2.747	0.532	3.279	N/A
	Top	-	1.448*	1.448	N/A		Top	-	1.448*	1.448	N/A
	Bottom	2.855	-	2.855	N/A		Bottom	2.991	-	2.991	N/A
	Left	0.780	0.387	1.167	N/A		Left	0.857	0.387	1.244	N/A

Simult Tx	Configuration	NR Band n66 (AWS)	5 GHz WLAN MIMO SAR (W/kg)	Σ SAR (W/kg)
		1	2	1+2
Phablet SAR	Back	-	1.448	1.448
	Front	-	0.532	0.532
	Top	-	1.448*	1.448
	Right	3.144	-	3.144
	Left	-	0.387	0.387

Notes:

1. No evaluation was performed to determine the aggregate 10g SAR for these configurations as the SPLS ratio between the antenna pairs was not greater than 0.10 per FCC KDB 447498 D01v06. See Section 12.7 for detailed SPLS ratio analysis.

12.7 SPLSR Evaluation and Analysis



Per FCC KDB Publication 447498 D01v06, when the sum of the standalone transmitters is more than 1.6 W/kg for 1g and 4 W/kg for 10g, the SAR sum to peak locations can be analyzed to determine SAR distribution overlaps. When the SAR peak to location ratio (shown below) for each pair of antennas is ≤ 0.04 for 1g and ≤ 0.10 for 10g, simultaneous SAR evaluation is not required. The distance between the transmitters was calculated using the following formula.

$$\text{Distance}_{\text{Tx1-Tx2}} = R_i = \sqrt{(x_1 - x_2)^2 + (y_1 - y_2)^2} \text{ (Body Worn, Phablet)}$$

$$\text{SPLS Ratio} = \frac{(SAR_1 + SAR_2)^{1.5}}{R_i}$$

12.7.1 Body Worn Side SPLSR Evaluation and Analysis

Table 12-20
Peak SAR Locations for Back Side

FCC ID: ZNFG900VM	 PCTEST Proud to be part of 	SAR EVALUATION REPORT		Approved by: Quality Manager
Document S/N: 1M2006040088-01-R1.ZNF	Test Dates: 06/25/20 – 08/05/20	DUT Type: Portable Handset	Page 146 of 159	

Mode/Band	x (mm)	y (mm)	Reported SAR (W/kg)
2.4 GHz WLAN Ant 1	8.60	57.60	0.198
2.4 GHz WLAN Ant 2	-5.80	84.00	0.336
Bluetooth	4.60	50.20	0.027
5 GHz WLAN Ant 2	1.00	74.00	0.285
5 GHz WLAN MIMO	1.00	73.00	0.607
UMTS 1900	5.50	-82.50	1.133
LTE Band 2 (PCS)	-11.50	-73.50	1.139

**Table 12-21
Back Side SAR to Peak Location Separation Ratio Calculations**

Antenna Pair		Standalone SAR (W/kg)		Standalone SAR Sum (W/kg)	Peak SAR Separation Distance (mm)	SPLS Ratio	Plot Number
Ant "a"	Ant "b"	a	b	a+b	D _{a-b}	$(a+b)^{1.5}/D_{a-b}$	
UMTS 1900	2.4 GHz WLAN Ant 1	1.133	0.198	1.331	140.13	0.01	1
UMTS 1900	2.4 GHz WLAN Ant 2	1.133	0.336	1.469	166.88	0.01	
2.4 GHz WLAN Ant 1	2.4 GHz WLAN Ant 2	0.198	0.336	0.534	30.07	0.01	
LTE Band 2 (PCS)	2.4 GHz WLAN Ant 1	1.139	0.198	1.337	132.63	0.01	2
LTE Band 2 (PCS)	2.4 GHz WLAN Ant 2	1.139	0.336	1.475	157.60	0.01	
2.4 GHz WLAN Ant 1	2.4 GHz WLAN Ant 2	0.198	0.336	0.534	30.07	0.01	
UMTS 1900	5 GHz WLAN MIMO	1.133	0.607	1.74	155.57	0.01	3
LTE Band 2 (PCS)	5 GHz WLAN MIMO	1.139	0.607	1.746	147.03	0.02	4
UMTS 1900	2.4 GHz WLAN Ant 1	1.133	0.198	1.331	140.13	0.01	5
UMTS 1900	5 GHz WLAN Ant 2	1.133	0.285	1.418	156.56	0.01	
2.4 GHz WLAN Ant 1	5 GHz WLAN Ant 2	0.198	0.285	0.483	18.08	0.02	
LTE Band 2 (PCS)	2.4 GHz WLAN Ant 1	1.139	0.198	1.337	132.63	0.01	6
LTE Band 2 (PCS)	5 GHz WLAN Ant 2	1.139	0.285	1.424	148.03	0.01	
2.4 GHz WLAN Ant 1	5 GHz WLAN Ant 2	0.198	0.285	0.483	18.08	0.02	
UMTS 1900	Bluetooth	1.133	0.027	1.16	132.70	0.01	7
UMTS 1900	5 GHz WLAN MIMO	1.133	0.607	1.74	155.57	0.01	
Bluetooth	5 GHz WLAN MIMO	0.027	0.607	0.634	23.08	0.02	
LTE Band 2 (PCS)	Bluetooth	1.139	0.027	1.166	124.74	0.01	8
LTE Band 2 (PCS)	5 GHz WLAN MIMO	1.139	0.607	1.746	147.03	0.02	
Bluetooth	5 GHz WLAN MIMO	0.027	0.607	0.634	23.08	0.02	



FCC ID: ZNFG900VM	 PCTEST Proud to be part of 	SAR EVALUATION REPORT		Approved by: Quality Manager
Document S/N: 1M2006040088-01-R1.ZNF	Test Dates: 06/25/20 – 08/05/20	DUT Type: Portable Handset	Page 147 of 159	

Table 12-22
Back Side SAR to Peak Location Separation Ratio Plots



12.7.2

Phablet Back Side SPLSR Evaluation and Analysis

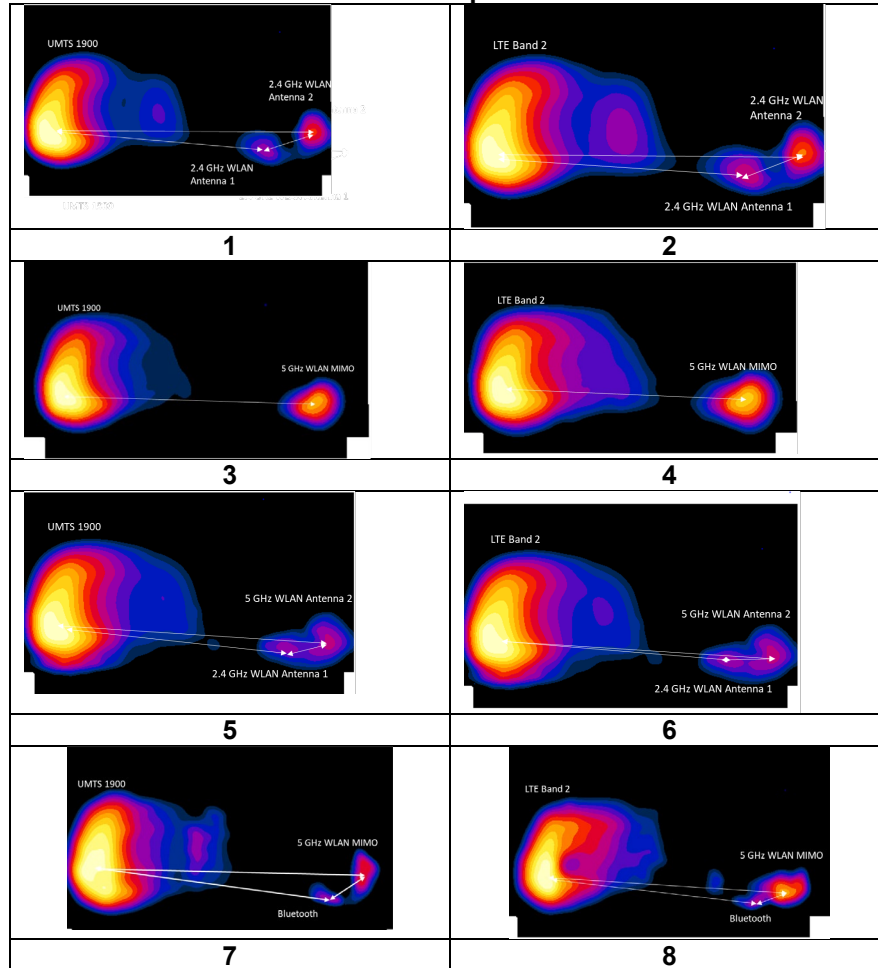
Table 12-23
Peak SAR Locations for Back Side

Mode/Band	x (mm)	y (mm)	Reported SAR (W/kg)
5 GHz WLAN Ant 1	9.60	73.10	1.146
5 GHz WLAN MIMO	1.10	71.10	1.448
UMTS 1900	-28.50	-76.50	2.916
LTE Band 2 (PCS)	-28.50	-75.00	2.810
LTE Band 66 (AWS)	-16.30	-78.40	2.850
PCS EVDO	-28.50	-78.00	2.793

FCC ID: ZNFG900VM	PCTEST Proud to be part of element	SAR EVALUATION REPORT	LG	Approved by: Quality Manager
Document S/N: 1M2006040088-01-R1.ZNF	Test Dates: 06/25/20 – 08/05/20	DUT Type: Portable Handset		Page 148 of 159

**Table 12-24
Back Side SAR to Peak Location Separation Ratio Calculations**

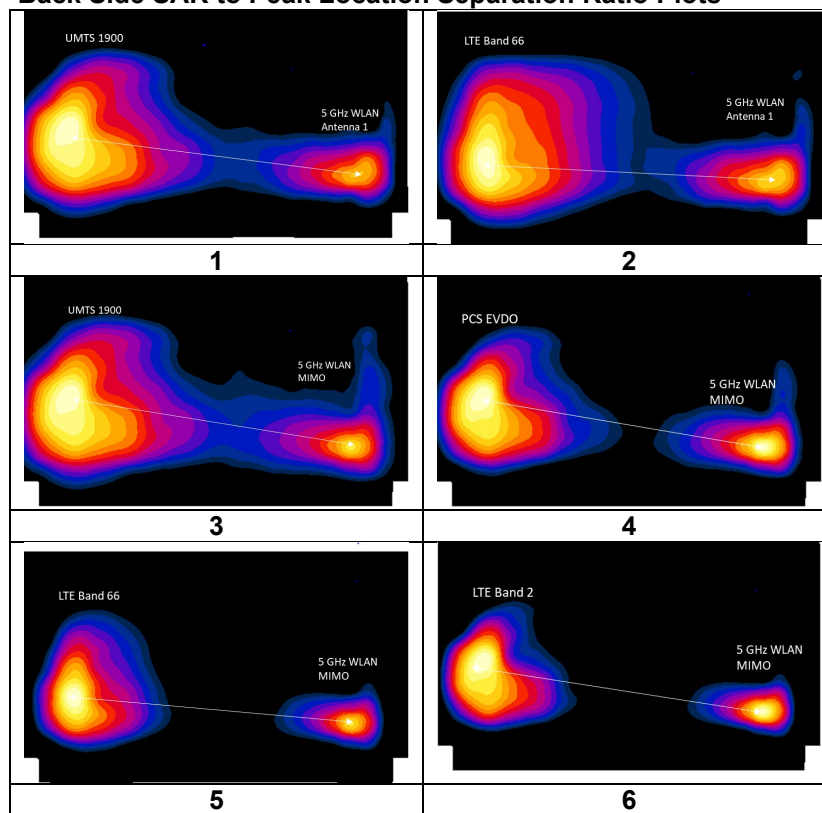

Antenna Pair		Standalone SAR (W/kg)		Standalone SAR Sum (W/kg)	Peak SAR Separation Distance (mm)	SPLS Ratio	Plot Number
Ant "a"	Ant "b"	a	b	a+b	D _{a-b}	$(a+b)^{1.5}/D_{a-b}$	
UMTS 1900	5 GHz WLAN Ant 1	2.916	1.146	4.062	154.38	0.05	1
LTE Band 66 (AWS)	5 GHz WLAN Ant 1	2.850	1.146	3.996	153.70	0.05	2
UMTS 1900	5 GHz WLAN MIMO	2.916	1.448	4.364	150.54	0.06	3
PCS EVDO	5 GHz WLAN MIMO	2.793	1.448	4.241	152.01	0.06	4
LTE Band 66 (AWS)	5 GHz WLAN MIMO	2.850	1.448	4.298	150.51	0.06	5
LTE Band 2 (PCS)	5 GHz WLAN MIMO	2.810	1.448	4.258	149.07	0.06	6

**Table 12-25
Back Side SAR to Peak Location Separation Ratio Plots**



12.8 Simultaneous Transmission Conclusion

The above numerical summed SAR results and SPLSR analysis for all the worst-case simultaneous transmission conditions were below the SAR limit. Therefore, the above analysis is sufficient to determine that simultaneous transmission cases will not exceed the SAR limit and therefore no measured volumetric simultaneous SAR summation is required per FCC KDB Publication 447498 D01v06 and IEEE 1528-2013 Section 6.3.4.1.2.

FCC ID: ZNFG900VM	 Proud to be part of 	SAR EVALUATION REPORT		Approved by: Quality Manager
Document S/N: 1M2006040088-01-R1.ZNF	Test Dates: 06/25/20 – 08/05/20	DUT Type: Portable Handset		Page 149 of 159

13 SAR MEASUREMENT VARIABILITY

13.1 Measurement Variability

Per FCC KDB Publication 865664 D01v01r04, SAR measurement variability was assessed for each frequency band, which was determined by the SAR probe calibration point and tissue-equivalent medium used for the device measurements. When both head and body tissue-equivalent media were required for SAR measurements in a frequency band, the variability measurement procedures were applied to the tissue medium with the highest measured SAR, using the highest measured SAR configuration for that tissue-equivalent medium. These additional measurements were repeated after the completion of all measurements requiring the same head or body tissue-equivalent medium in a frequency band. The test device was returned to ambient conditions (normal room temperature) with the battery fully charged before it was re-mounted on the device holder for the repeated measurement(s) to minimize any unexpected variations in the repeated results.

SAR Measurement Variability was assessed using the following procedures for each frequency band:

- 1) When the original highest measured SAR is ≥ 0.80 W/kg, the measurement was repeated once.
- 2) A second repeated measurement was performed only if the ratio of largest to smallest SAR for the original and first repeated measurements was > 1.20 or when the original or repeated measurement was ≥ 1.45 W/kg (~ 10% from the 1g SAR limit).
- 3) A third repeated measurement was performed only if the original, first or second repeated measurement was ≥ 1.5 W/kg and the ratio of largest to smallest SAR for the original, first and second repeated measurements is > 1.20 .
- 4) Repeated measurements are not required when the original highest measured SAR is < 0.80 W/kg
- 5) When 10g SAR measurement is considered, a factor of 2.5 is applied to the thresholds above.

**Table 13-1
Body SAR Measurement Variability Results**



BODY VARIABILITY RESULTS												
Band	FREQUENCY		Mode	Service	Side	Spacing	Measured SAR (1g)	1st Repeated SAR (1g)	Ratio	2nd Repeated SAR (1g)	Ratio	3rd Repeated SAR (1g)
	MHz	Ch.					(W/kg)	(W/kg)		(W/kg)		(W/kg)
1750	1770.00	132572	LTE Band 66 (AWS), 20 MHz Bandwidth	QPSK, 50 RB, 25 RB Offset	bottom	10 mm	0.840	0.838	1.00	N/A	N/A	N/A
1900	1880.00	9400	UMTS 1900	RMC	back	10 mm	1.070	1.010	1.06	N/A	N/A	N/A
ANSI / IEEE C95.1 1992 - SAFETY LIMIT Spatial Peak Uncontrolled Exposure/General Population							Body 1.6 W/kg (mW/g) averaged over 1 gram					

**Table 13-2
Phablet SAR Measurement Variability Results**

PHABLET VARIABILITY RESULTS													
Band	FREQUENCY		Mode	Service	Dual Display Accessory Configuration	Side	Spacing	Measured SAR (10g)	1st Repeated SAR (10g)	Ratio	2nd Repeated SAR (10g)	Ratio	3rd Repeated SAR (10g)
	MHz	Ch.						(W/kg)	(W/kg)		(W/kg)		(W/kg)
1750	1770.00	132572	LTE Band 66 (AWS), 20 MHz Bandwidth	QPSK, 1 RB, 0 RB Offset	#1	back	0 mm	2.850	2.850	1.00	N/A	N/A	N/A
1900	1880.00	18900	LTE Band 2 (PCS), 20 MHz Bandwidth	QPSK, 1 RB, 0 RB Offset	#1	bottom	0 mm	2.970	2.970	1.00	N/A	N/A	N/A
ANSI / IEEE C95.1 1992 - SAFETY LIMIT Spatial Peak Uncontrolled Exposure/General Population							Phablet 4.0 W/kg (mW/g) averaged over 10 grams						

13.2 Measurement Uncertainty

The measured SAR was < 1.5 W/kg for 1g and < 3.75 W/kg for 10g for all frequency bands. Therefore, per KDB Publication 865664 D01v01r04, the extended measurement uncertainty analysis per IEEE 1528-2013 was not required.

FCC ID: ZNFG900VM	 PCTEST Proud to be part of 	SAR EVALUATION REPORT		Approved by: Quality Manager
Document S/N: 1M2006040088-01-R1.ZNF	Test Dates: 06/25/20 – 08/05/20	DUT Type: Portable Handset		Page 150 of 159

14 ADDITIONAL TESTING PER FCC GUIDANCE

14.1 Tuner Testing

Per April 2019 TCB Workshop Notes, the following test procedures were followed to demonstrate that the SAR results in Section 11 represented the appropriate SAR test conditions. For bands with dynamic tuning implemented, SAR was measured according to the required FCC SAR test procedures with the dynamic tuner active to allow the device to automatically tune to the antenna state for the respective RF exposure test configurations. Per FCC Guidance, during NR testing the device was configured with the tuner state selected by the device in LTE mode with auto-tune active at the same frequency. Additional single point SAR time-sweep measurements were evaluated for other tuner states to determine that the other tuner configurations would result in equivalent or lower SAR values. The additional tuner hardware has no influence on the antenna characteristics, other than impedance matching.

To evaluate all the tuner states, the 32 tuner states were divided among the aggregate band, mode and exposure combinations. Single point time-sweep measurements were performed at the peak SAR location determined by the zoom scan of the configuration with the highest reported SAR for each combination. The tuner state was able to be established remotely so that the device was not moved for the entire series of single point SAR for the tuner states in each combination. The SAR probe remained stationary at the same position throughout the entire series of single point measurements for each combination. When the single point SAR or 1g SAR was > 1.2 W/kg for a particular band/mode/exposure condition, point SAR measurements were made for all 32 states.

The operational description contains more information about the design and implementation of the dynamic antenna tuning.

Table 14-1
UMTS/CDMA Supplemental Head SAR Data

Supplemental Head SAR Data			
UMTS B5		CDMA BC0	
RMC		EVDO Rev. A	
Test Position	Left Cheek	Test Position	Left Cheek
Frequency (MHz)	836.6	Frequency (MHz)	836.52
Channel	4183	Channel	384
Measured 1g SAR (W/kg)	0.202	Measured 1g SAR (W/kg)	0.165
Average Value of Time Sweep (W/kg)		Average Value of Time Sweep (W/kg)	
Auto-tune (State 8)	0.242	Auto-tune (State 8)	0.220
Default (State 8)	0.236	Default (State 8)	0.219
State 2	0.186	State 4	0.182
State 8	0.236	State 8	0.219
State 15	0.138	State 13	0.059
State 23	0.233	State 28	0.063



FCC ID: ZNFG900VM	 PCTEST Proud to be part of element	SAR EVALUATION REPORT	 LG	Approved by: Quality Manager
Document S/N: 1M2006040088-01-R1.ZNF	Test Dates: 06/25/20 – 08/05/20	DUT Type: Portable Handset	Page 151 of 159	

Table 14-2
LTE Supplemental Head SAR Data

Supplemental Head SAR Data					
LTE B12		LTE B13		LTE B5	
QPSK, 10 MHz Bandwidth, 1 RB, 25 RB Offset		QPSK, 10 MHz Bandwidth, 1 RB, 25 RB Offset		QPSK, 10 MHz Bandwidth, 1 RB, 0 RB Offset	
Test Position	Left Cheek	Test Position	Left Cheek	Test Position	Left Cheek
Frequency (MHz)	707.5	Frequency (MHz)	782.0	Frequency (MHz)	836.5
Channel	23095	Channel	23230	Channel	20525
Measured 1g SAR (W/kg)	0.108	Measured 1g SAR (W/kg)	0.161	Measured 1g SAR (W/kg)	0.188
Average Value of Time Sweep (W/kg)		Average Value of Time Sweep (W/kg)		Average Value of Time Sweep (W/kg)	
Auto-tune (State 13)	0.138	Auto-tune (State 4)	0.197	Auto-tune (State 8)	0.230
Default (State 12)	0.136	Default (State 3)	0.201	Default (State 8)	0.227
State 3	0.030	State 4	0.199	State 1	0.103
State 10	0.128	State 14	0.061	State 8	0.227
State 13	0.137	State 24	0.086	State 17	0.058
State 17	0.012	State 30	0.023	State 27	0.091

Table 14-3
NR Supplemental Head SAR Data

Supplemental Head SAR Data	
NR Band n5	
DFT-s-OFDM QPSK, 20 MHz Bandwidth, 50 RB, 28 RB Offset	
Test Position	Left Cheek
Frequency (MHz)	836.5
Channel	167300
Measured 1g SAR (W/kg)	0.130
Average Value of Time Sweep (W/kg)	
Auto-tune (State 8)	0.171
Default (State 8)	0.171
State 8	0.171
State 12	0.032
State 22	0.077
State 31	0.102



FCC ID: ZNFG900VM	 PCTEST Proud to be part of 	SAR EVALUATION REPORT		Approved by: Quality Manager
Document S/N: 1M2006040088-01-R1.ZNF	Test Dates: 06/25/20 – 08/05/20	DUT Type: Portable Handset	Page 152 of 159	

Table 14-4
UMTS/CDMA Supplemental Body SAR Data

Supplemental Body SAR Data			
UMTS B5		CDMA BC0	
RMC		EVDO	
Test Position	Back	Test Position	Back
Spacing	10 mm	Spacing	10 mm
Frequency (MHz)	836.6	Frequency (MHz)	836.52
Channel	4183	Channel	384
Measured 1g SAR (W/kg)	0.707	Measured 1g SAR (W/kg)	0.671
Average Value of Time Sweep (W/kg)		Average Value of Time Sweep (W/kg)	
Auto-tune (State 8)	1.059	Auto-tune (State 8)	0.887
Default (State 8)	1.068	Default (State 8)	0.845
State 5	0.703	State 3	0.486
State 6	0.378	State 8	0.845
State 8	1.068	State 9	0.489
State 11	0.211	State 20	0.793
State 19	0.974	State 29	0.37







FCC ID: ZNFG900VM	 PCTEST Proud to be part of 	SAR EVALUATION REPORT		Approved by: Quality Manager
Document S/N: 1M2006040088-01-R1.ZNF	Test Dates: 06/25/20 – 08/05/20	DUT Type: Portable Handset	Page 153 of 159	

Table 14-5
LTE Supplemental Body SAR Data

Supplemental Body SAR Data					
LTE B12		LTE B13		LTE B5	
QPSK, 10 MHz Bandwidth, 1 RB, 25 RB Offset		QPSK, 10 MHz Bandwidth, 1 RB, 25 RB Offset		QPSK, 10 MHz Bandwidth, 1 RB, 0 RB Offset	
Test Position	Back	Test Position	Back	Test Position	Back
Spacing	10 mm	Spacing	10 mm	Spacing	10 mm
Frequency (MHz)	707.5	Frequency (MHz)	782.0	Frequency (MHz)	836.5
Channel	23095	Channel	23230	Channel	20525
Measured 1g SAR (W/kg)	0.298	Measured 1g SAR (W/kg)	0.541	Measured 1g SAR (W/kg)	0.655
Average Value of Time Sweep (W/kg)		Average Value of Time Sweep (W/kg)		Average Value of Time Sweep (W/kg)	
Auto-tune (State 12)	0.445	Auto-tune (State 3)	0.814	Auto-tune (State 8)	0.994
Default (State 12)	0.437	Default (State 3)	0.815	Default (State 8)	1.059
State 6	0.438	State 2	0.772	State 7	1.014
State 12	0.437	State 3	0.815	State 8	1.059
State 16	0.304	State 8	0.547	State 11	0.210
State 23	0.078	State 18	0.51	State 13	0.277
State 25	0.075	State 26	0.143	State 21	0.997

Table 14-6
NR Supplemental Body SAR Data



Supplemental Body SAR Data	
NR Band n5	
DFT-s-OFDM QPSK, 20 MHz Bandwidth, 50 RB, 28 RB Offset	
Test Position	Back
Spacing	10 mm
Frequency (MHz)	836.5
Channel	167300
Measured 1g SAR (W/kg)	0.566
Average Value of Time Sweep (W/kg)	
Auto-tune (State 8)	0.840
Default (State 8)	0.840
State 3	0.484
State 8	0.840
State 17	0.745
State 26	0.396
State 32	0.402

FCC ID: ZNFG900VM	 PCTEST Proud to be part of 	SAR EVALUATION REPORT	 LG	Approved by: Quality Manager
Document S/N: 1M2006040088-01-R1.ZNF	Test Dates: 06/25/20 – 08/05/20	DUT Type: Portable Handset	Page 154 of 159	

Manufacturer	Model	Description	Cal Date	Cal Interval	Cal Due	Serial Number
Agilent	8594A	(9kHz-2.9GHz) Spectrum Analyzer	N/A	N/A	N/A	3051A00187
Agilent	8735ES	S-Parameter Network Analyzer	12/31/2019	Annual	12/31/2020	US39170122
Agilent	8735ES	S-Parameter Network Analyzer	8/26/2019	Annual	8/26/2020	MY40020570
Agilent	8735ES	S-Parameter Vector Network Analyzer	9/19/2019	Annual	9/19/2020	MY40020841
Agilent	E4438C	ESG Vector Signal Generator	3/8/2019	Biennial	3/8/2021	MY42082385
Agilent	E4438C	ESG Vector Signal Generator	3/1/2019	Biennial	3/1/2021	MY45090700
Agilent	E4438C	ESG Vector Signal Generator	12/13/2019	Annual	12/13/2020	MY42082659
Agilent	E5515C	8960 Series 10 Wireless Communications Test Set	2/10/2020	Annual	2/10/2021	GB42230325
Agilent	E5515C	Wireless Communications Test Set	1/14/2020	Triennial	1/14/2023	GB43304447
Agilent	E5515C	Wireless Communications Test Set	2/26/2020	Annual	2/26/2021	GB44400860
Agilent	E5515C	Wireless Communications Test Set	9/25/2019	Annual	9/25/2020	GB43304278
Agilent	N5182A	MXG Vector Signal Generator	5/13/2020	Annual	5/13/2021	MY47420603
Agilent	N5182A	MXG Vector Signal Generator	2/19/2020	Annual	2/19/2021	MY47420651
Amplifier Research	1551G6	Amplifier	CBT	N/A	CBT	433972
Amplifier Research	1551G6	Amplifier	CBT	N/A	CBT	433974
Amplifier Research	1551G6	Amplifier	CBT	N/A	CBT	433976
Anritsu	MA24106A	USB Power Sensor	2/27/2020	Annual	2/27/2021	1244524
Anritsu	MA24106A	USB Power Sensor	10/10/2019	Annual	10/10/2020	1344545
Anritsu	MA24106A	USB Power Sensor	10/10/2019	Annual	10/10/2020	1344559
Anritsu	MA2411B	Pulse Power Sensor	12/4/2019	Annual	12/4/2020	1126066
Anritsu	MA2495A	Power Meter	12/17/2019	Annual	12/17/2020	941001
Anritsu	MA2496A	Power Meter	3/23/2020	Annual	3/23/2021	1351001
Anritsu	MN8110B	I/Q Adaptor	CBT	N/A	CBT	626174781
Anritsu	MT8821C	Radio Communication Analyzer	3/10/2020	Annual	3/10/2021	620091190
Anritsu	MT8821C	Radio Communication Analyzer	2/22/2020	Annual	2/22/2021	6261895213
Anritsu	MT8821C	Radio Communication Analyzer	11/22/2019	Annual	11/22/2020	626204475
Anritsu	MT8822A	Wireless Connectivity Test Set	8/8/2019	Annual	8/8/2020	6261782395
COMTECH	AR85729-5	Solid State Amplifier	CBT	N/A	CBT	M155A00-1009
COMTECH	AR85729-5/5759B	Solid State Amplifier	CBT	N/A	CBT	M3W1A00-3002
Control Company	4040	Therm./Clock/Humidity Monitor	6/29/2019	Biennial	6/29/2021	192291455
Control Company	4040	Therm./Clock/Humidity Monitor	6/29/2019	Biennial	6/29/2021	192291460
Control Company	4040	Therm./Clock/Humidity Monitor	6/29/2019	Biennial	6/29/2021	192291463
Control Company	4352	Long Stem Thermometer	1/24/2020	Biennial	1/24/2022	200043588
Control Company	4352	Long Stem Thermometer	1/24/2020	Biennial	1/24/2022	200043655
Control Company	4352	Long Stem Thermometer	1/24/2020	Biennial	1/24/2022	200043647
Control Company	4352	Ultra Long Stem Thermometer	11/29/2018	Biennial	11/29/2020	181766816
Control Company	4352	Ultra Long Stem Thermometer	11/29/2018	Biennial	11/29/2020	181766817
Keysight	772D	Dual Directional Coupler	CBT	N/A	CBT	MY52180215
MCL	BW-N6W5+	6dB Attenuator	CBT	N/A	CBT	1139
MiniCircuits	SLP-2400+	Low Pass Filter	CBT	N/A	CBT	R8979500903
MiniCircuits	VLF-6000+	Low Pass Filter	CBT	N/A	CBT	N/A
MiniCircuits	VLF-6000+	Low Pass Filter	CBT	N/A	CBT	N/A
MiniCircuits	BW-N20M5	Power Attenuator	CBT	N/A	CBT	1226
MiniCircuits	BW-N20W5+	DC to 18 GHz Precision Fixed 20 dB Attenuator	CBT	N/A	CBT	N/A
Mini-Circuits	NLP-1200+	Low Pass Filter DC to 1000 MHz	CBT	N/A	CBT	N/A
Mini-Circuits	NLP-2950+	Low Pass Filter DC to 2700 MHz	CBT	N/A	CBT	N/A
Narda	BW-53W2	Attenuator (3dB)	CBT	N/A	CBT	120
NI	4474	Data Acquisition Card	CBT	N/A	CBT	N/A
Pasternack	PE2209-10	Bidirectional Coupler	CBT	N/A	CBT	N/A
Rohde & Schwarz	CMW500	Radio Communication Tester	3/27/2020	Annual	3/27/2021	128633
Rohde & Schwarz	CMW500	Radio Communication Tester	8/14/2019	Annual	8/14/2020	140144
Rohde & Schwarz	CMW500	Radio Communication Tester	10/4/2019	Annual	10/4/2020	166462
Rohde & Schwarz	CMW500	Wideband Radio Communication Tester	2/4/2020	Annual	2/4/2021	162125
Rohde & Schwarz	CMW500	Wideband Radio Communication Tester	11/14/2019	Annual	11/14/2020	164948
Rohde & Schwarz	ZNL6E	Vector Network Analyzer	10/11/2019	Annual	10/11/2020	101307
Rohde & Schwarz	CMW500	Wideband Radio Communication Tester	7/12/2019	Annual	7/12/2020	145645
Rohde & Schwarz	CMW500	Wideband Radio Communication Tester	7/24/2019	Annual	7/24/2020	151849
SPEAG	D1750V2	1750 MHz SAR Dipole	10/22/2018	Biennial	10/22/2020	1150
SPEAG	D1765V2	1765 MHz SAR Dipole	5/23/2018	Triennial	5/23/2021	1008
SPEAG	D1900V2	1900 MHz SAR Dipole	10/23/2018	Biennial	10/23/2020	5d080
SPEAG	D1900V2	1900 MHz SAR Dipole	2/21/2019	Biennial	2/21/2021	5d148
SPEAG	D1900V2	1900 MHz SAR Dipole	10/23/2018	Biennial	10/23/2020	5d149
SPEAG	D2450V2	2450 MHz SAR Dipole	2/10/2020	Annual	2/10/2021	882
SPEAG	D2450V2	2450 MHz SAR Dipole	8/14/2019	Annual	8/14/2020	719
SPEAG	D3500V2	3500 MHz SAR Dipole	1/11/2018	Triennial	1/11/2021	1059
SPEAG	D5GHzV2	5 GHz SAR Dipole	2/18/2020	Annual	2/18/2021	1120
SPEAG	D750V3	750 MHz Dipole	3/11/2020	Annual	3/11/2021	1054
SPEAG	D835V2	835 MHz SAR Dipole	3/13/2019	Biennial	3/13/2021	4d047
SPEAG	D835V2	835 MHz SAR Dipole	1/13/2020	Annual	1/13/2021	4d132
SPEAG	DAE4	Dasy Data Acquisition Electronics	4/15/2020	Annual	4/15/2021	1502
SPEAG	DAE4	Dasy Data Acquisition Electronics	11/13/2019	Annual	11/13/2020	1466
SPEAG	DAE4	Dasy Data Acquisition Electronics	9/17/2019	Annual	9/17/2020	1333
SPEAG	DAE4	Dasy Data Acquisition Electronics	7/11/2019	Annual	7/11/2020	1322
SPEAG	DAE4	Dasy Data Acquisition Electronics	3/12/2020	Annual	3/12/2021	1368
SPEAG	DAE4	Dasy Data Acquisition Electronics	4/15/2020	Annual	4/15/2021	1407
SPEAG	DAE4	Dasy Data Acquisition Electronics	1/13/2020	Annual	1/13/2021	1530
SPEAG	DAE4	Dasy Data Acquisition Electronics	1/13/2020	Annual	1/13/2021	1558
SPEAG	DAE4	Dasy Data Acquisition Electronics	6/18/2020	Annual	6/18/2021	1334
SPEAG	DAE4	Dasy Data Acquisition Electronics	12/5/2019	Annual	12/5/2020	1533
SPEAG	DAK-3.5	Dielectric Assessment Kit	10/22/2019	Annual	10/22/2020	1091
SPEAG	EX3DV4	SAR Probe	1/21/2020	Annual	1/21/2021	3589
SPEAG	EX3DV4	SAR Probe	9/19/2019	Annual	9/19/2020	7551
SPEAG	EX3DV4	SAR Probe	4/21/2020	Annual	4/21/2021	7357
SPEAG	EX3DV4	SAR Probe	6/23/2020	Annual	6/23/2021	7409
SPEAG	EX3DV4	SAR Probe	7/16/2019	Annual	7/16/2020	7410
SPEAG	EX3DV4	SAR Probe	1/21/2020	Annual	1/21/2021	7488
SPEAG	EX3DV4	SAR Probe	12/11/2019	Annual	12/11/2020	7570
SPEAG	EX3DV4	SAR Probe	12/11/2019	Annual	12/11/2020	7571
SPEAG	EX3DV4	SAR Probe	4/21/2020	Annual	4/21/2021	7402
SPEAG	EX3DV4	SAR Probe	11/15/2019	Annual	11/15/2020	7565

Note: Equipment was solely used during its calibration period



Note: CBT (Calibrated Before Testing). Prior to testing, the measurement paths containing a cable, amplifier, attenuator, coupler or filter were connected to a calibrated source (i.e. a signal generator) to determine the losses of the measurement path. The power meter offset was then adjusted to compensate for the measurement system losses. This level offset is stored within the power meter before measurements are made. This calibration verification procedure applies to the system verification and output power measurements. The calibrated reading is then taken directly from the power meter after compensation of the losses for all final power measurements.

FCC ID: ZNFG900VM		SAR EVALUATION REPORT		Approved by: Quality Manager
Document S/N: 1M2006040088-01-R1.ZNF	Test Dates: 06/25/20 – 08/05/20	DUT Type: Portable Handset		Page 155 of 159

16

MEASUREMENT UNCERTAINTIES

a	c	d	e= f(d,k)	f	g	h = c x f/e	i = c x g/e	k
Uncertainty Component	Tol. (± %)	Prob. Dist.	Div.	c _i 1gm	c _i 10 gms	1gm u _i (± %)	10gms u _i (± %)	v _i
Measurement System								
Probe Calibration	6.55	N	1	1.0	1.0	6.6	6.6	∞
Axial Isotropy	0.25	N	1	0.7	0.7	0.2	0.2	∞
Hemishperical Isotropy	1.3	N	1	0.7	0.7	0.9	0.9	∞
Boundary Effect	2.0	R	1.73	1.0	1.0	1.2	1.2	∞
Linearity	0.3	N	1	1.0	1.0	0.3	0.3	∞
System Detection Limits	0.25	R	1.73	1.0	1.0	0.1	0.1	∞
Readout Electronics	0.3	N	1	1.0	1.0	0.3	0.3	∞
Response Time	0.8	R	1.73	1.0	1.0	0.5	0.5	∞
Integration Time	2.6	R	1.73	1.0	1.0	1.5	1.5	∞
RF Ambient Conditions - Noise	3.0	R	1.73	1.0	1.0	1.7	1.7	∞
RF Ambient Conditions - Reflections	3.0	R	1.73	1.0	1.0	1.7	1.7	∞
Probe Positioner Mechanical Tolerance	0.4	R	1.73	1.0	1.0	0.2	0.2	∞
Probe Positioning w/ respect to Phantom	6.7	R	1.73	1.0	1.0	3.9	3.9	∞
Extrapolation, Interpolation & Integration algorithms for Max. SAR Evaluation	4.0	R	1.73	1.0	1.0	2.3	2.3	∞
Test Sample Related								
Test Sample Positioning	2.7	N	1	1.0	1.0	2.7	2.7	35
Device Holder Uncertainty	1.67	N	1	1.0	1.0	1.7	1.7	5
Output Power Variation - SAR drift measurement	5.0	R	1.73	1.0	1.0	2.9	2.9	∞
SAR Scaling	0.0	R	1.73	1.0	1.0	0.0	0.0	∞
Phantom & Tissue Parameters								
Phantom Uncertainty (Shape & Thickness tolerances)	7.6	R	1.73	1.0	1.0	4.4	4.4	∞
Liquid Conductivity - measurement uncertainty	4.2	N	1	0.78	0.71	3.3	3.0	10
Liquid Permittivity - measurement uncertainty	4.1	N	1	0.23	0.26	1.0	1.1	10
Liquid Conductivity - Temperature Uncertainty	3.4	R	1.73	0.78	0.71	1.5	1.4	∞
Liquid Permittivity - Temperature Uncertainty	0.6	R	1.73	0.23	0.26	0.1	0.1	∞
Liquid Conductivity - deviation from target values	5.0	R	1.73	0.64	0.43	1.8	1.2	∞
Liquid Permittivity - deviation from target values	5.0	R	1.73	0.60	0.49	1.7	1.4	∞
Combined Standard Uncertainty (k=1)	RSS					11.5	11.3	60
Expanded Uncertainty (95% CONFIDENCE LEVEL)	k=2					23.0	22.6	



FCC ID: ZNFG900VM	 PCTEST Proud to be part of 	SAR EVALUATION REPORT		Approved by: Quality Manager
Document S/N: 1M2006040088-01-R1.ZNF	Test Dates: 06/25/20 – 08/05/20	DUT Type: Portable Handset	Page 156 of 159	

17 CONCLUSION

17.1 Measurement Conclusion



The SAR evaluation indicates that the EUT complies with the RF radiation exposure limits of the FCC and Innovation, Science, and Economic Development Canada, with respect to all parameters subject to this test. These measurements were taken to simulate the RF effects of RF exposure under worst-case conditions. Precise laboratory measures were taken to assure repeatability of the tests. The results and statements relate only to the item(s) tested.

Please note that the absorption and distribution of electromagnetic energy in the body are very complex phenomena that depend on the mass, shape, and size of the body, the orientation of the body with respect to the field vectors, and the electrical properties of both the body and the environment. Other variables that may play a substantial role in possible biological effects are those that characterize the environment (e.g. ambient temperature, air velocity, relative humidity, and body insulation) and those that characterize the individual (e.g. age, gender, activity level, debilitation, or disease). Because various factors may interact with one another to vary the specific biological outcome of an exposure to electromagnetic fields, any protection guide should consider maximal amplification of biological effects as a result of field-body interactions, environmental conditions, and physiological variables. [3]



FCC ID: ZNFG900VM	 PCTEST Proud to be part of 	SAR EVALUATION REPORT	 LG	Approved by: Quality Manager
Document S/N: 1M2006040088-01-R1.ZNF	Test Dates: 06/25/20 – 08/05/20	DUT Type: Portable Handset	Page 157 of 159	

18 REFERENCES

- [1] Federal Communications Commission, ET Docket 93-62, Guidelines for Evaluating the Environmental Effects of Radiofrequency Radiation, Aug. 1996.
- [2] ANSI/IEEE C95.1-2005, American National Standard safety levels with respect to human exposure to radio frequency electromagnetic fields, 3kHz to 300GHz, New York: IEEE, 2006.
- [3] ANSI/IEEE C95.1-1992, American National Standard safety levels with respect to human exposure to radio frequency electromagnetic fields, 3kHz to 300GHz, New York: IEEE, Sept. 1992.
- [4] ANSI/IEEE C95.3-2002, IEEE Recommended Practice for the Measurement of Potentially Hazardous Electromagnetic Fields - RF and Microwave, New York: IEEE, December 2002.
- [5] IEEE Standards Coordinating Committee 39 –Standards Coordinating Committee 34 – IEEE Std. 1528-2013, IEEE Recommended Practice for Determining the Peak Spatial-Average Specific Absorption Rate (SAR) in the Human Head from Wireless Communications Devices: Measurement Techniques.
- [6] NCRP, National Council on Radiation Protection and Measurements, Biological Effects and Exposure Criteria for RadioFrequency Electromagnetic Fields, NCRP Report No. 86, 1986. Reprinted Feb. 1995.
- [7] T. Schmid, O. Egger, N. Kuster, Automated E-field scanning system for dosimetric assessments, IEEE Transaction on Microwave Theory and Techniques, vol. 44, Jan. 1996, pp. 105-113.
- [8] K. Pokovic, T. Schmid, N. Kuster, Robust setup for precise calibration of E-field probes in tissue simulating liquids at mobile communications frequencies, ICECOM97, Oct. 1997, pp. 1 -124.
- [9] K. Pokovic, T. Schmid, and N. Kuster, E-field Probe with improved isotropy in brain simulating liquids, Proceedings of the ELMAR, Zadar, Croatia, June 23-25, 1996, pp. 172-175.
- [10] Schmid & Partner Engineering AG, Application Note: Data Storage and Evaluation, June 1998, p2.
- [11] V. Hombach, K. Meier, M. Burkhardt, E. Kuhn, N. Kuster, The Dependence of EM Energy Absorption upon Human Modeling at 900 MHz, IEEE Transaction on Microwave Theory and Techniques, vol. 44 no. 10, Oct. 1996, pp. 1865-1873.
- [12] N. Kuster and Q. Balzano, Energy absorption mechanism by biological bodies in the near field of dipole antennas above 300MHz, IEEE Transaction on Vehicular Technology, vol. 41, no. 1, Feb. 1992, pp. 17-23.
- [13] G. Hartsgrove, A. Kraszewski, A. Surowiec, Simulated Biological Materials for Electromagnetic Radiation Absorption Studies, University of Ottawa, Bioelectromagnetics, Canada: 1987, pp. 29-36.
- [14] Q. Balzano, O. Garay, T. Manning Jr., Electromagnetic Energy Exposure of Simulated Users of Portable Cellular Telephones, IEEE Transactions on Vehicular Technology, vol. 44, no.3, Aug. 1995.
- [15] W. Gander, Computermathematik, Birkhaeuser, Basel, 1992.
- [16] W.H. Press, S.A. Teukolsky, W.T. Vetterling, and B.P. Flannery, Numerical Recipes in C, The Art of Scientific Computing, Second edition, Cambridge University Press, 1992.
- [17] N. Kuster, R. Kastle, T. Schmid, Dosimetric evaluation of mobile communications equipment with known precision, IEEE Transaction on Communications, vol. E80-B, no. 5, May 1997, pp. 645-652.

FCC ID: ZNFG900VM	 PCTEST Proud to be part of 	SAR EVALUATION REPORT	 LG	Approved by: Quality Manager
Document S/N: 1M2006040088-01-R1.ZNF	Test Dates: 06/25/20 – 08/05/20	DUT Type: Portable Handset	Page 158 of 159	

- [18] CENELEC CLC/SC111B, European Prestandard (prENV 50166-2), Human Exposure to Electromagnetic Fields High-frequency: 10kHz-300GHz, Jan. 1995.
- [19] Prof. Dr. Niels Kuster, ETH, Eidgenössische Technische Hochschule Zürich, Dosimetric Evaluation of the Cellular Phone.
- [20] IEC 62209-1, Measurement procedure for the assessment of specific absorption rate of human exposure to radio frequency fields from hand-held and body-mounted wireless communication devices - Part 1: Devices used next to the ear (Frequency range of 300 MHz to 6 GHz), July 2016.
- [21] Innovation, Science, Economic Development Canada RSS-102 Radio Frequency Exposure Compliance of Radiocommunication Apparatus (All Frequency Bands) Issue 5, March 2015.
- [22] Health Canada Safety Code 6 Limits of Human Exposure to Radio Frequency Electromagnetic Fields in the Frequency Range from 3 kHz – 300 GHz, 2015
- [23] FCC SAR Test Procedures for 2G-3G Devices, Mobile Hotspot and UMPC Devices KDB Publications 941225, D01-D07
- [24] SAR Measurement Guidance for IEEE 802.11 Transmitters, KDB Publication 248227 D01
- [25] FCC SAR Considerations for Handsets with Multiple Transmitters and Antennas, KDB Publications 648474 D03-D04
- [26] FCC SAR Evaluation Considerations for Laptop, Notebook, Netbook and Tablet Computers, FCC KDB Publication 616217 D04
- [27] FCC SAR Measurement and Reporting Requirements for 100MHz – 6 GHz, KDB Publications 865664 D01-D02
- [28] FCC General RF Exposure Guidance and SAR Procedures for Dongles, KDB Publication 447498, D01-D02
- [29] Anexo à Resolução No. 533, de 10 de Setembro de 2009.
- [30] IEC 62209-2, Human exposure to radio frequency fields from hand-held and body-mounted wireless communication devices - Human models, instrumentation, and procedures - Part 2: Procedure to determine the specific absorption rate (SAR) for wireless communication devices used in close proximity to the human body (frequency range of 30 MHz to 6 GHz), Mar. 2010.

FCC ID: ZNFG900VM	 PCTEST Proud to be part of 	SAR EVALUATION REPORT	 LG	Approved by: Quality Manager
Document S/N: 1M2006040088-01-R1.ZNF	Test Dates: 06/25/20 – 08/05/20	DUT Type: Portable Handset	Page 159 of 159	