



SAR EVALUATION REPORT

Applicant Name:
 LG Electronics MobileComm U.S.A., Inc.
 1000 Sylvan Avenue,
 Englewood Cliffs, NJ 07632
 USA

Date of Testing:
 07/05/12 - 08/23/12
Test Site/Location:
 PCTEST Lab, Columbia, MD, USA
Document Serial No.:
 0Y1207050909-R1.ZNF

FCC ID: ZNFE970

APPLICANT: LG ELECTRONICS MOBILECOMM U.S.A., INC.

DUT Type: Portable Handset
Application Type: Certification
FCC Rule Part(s): CFR §2.1093
Model(s): E970, LGE970, LG-E970

Band & Mode	Tx Frequency	Conducted Power [dBm]	SAR		
			1 gm Head (W/kg)	1 gm Body-Worn (W/kg)	1 gm Hotspot (W/kg)
GSM/GPRS/EDGE 850	824.20 - 848.80 MHz	33.67	0.57	0.73	0.74
WCDMA/HSPA 850	826.40 - 846.60 MHz	23.34	0.42	0.54	0.63
GSM/GPRS/EDGE 1900	1850.20 - 1909.80 MHz	30.34	0.45	0.52	0.52
WCDMA/HSPA 1900	1852.4 - 1907.6 MHz	23.42	0.46	0.58	0.58
LTE Band 17	706.5 - 713.5 MHz	23.67	0.23	0.45	0.45
LTE Band 5 (Cell)	826.5 - 846.5 MHz	23.64	0.49	0.64	0.73
LTE Band 4 (AWS)	1712.5 - 1752.5 MHz	23.64	0.67	1.22	1.22
LTE Band 2 (PCS)	1852.5 - 1907.5 MHz	23.51	0.64	0.62	0.62
2.4 GHz WLAN	2412 - 2462 MHz	16.27	0.33	0.49	0.49
5.8 GHz WLAN	5745 - 5825 MHz	14.26	0.06	0.13	
5.2 GHz WLAN	5180 - 5240 MHz	14.57	0.10	0.42	
5.3 GHz WLAN	5260 - 5320 MHz	14.53	0.20	0.33	
5.5 GHz WLAN	5500 - 5700 MHz	14.47	0.11	0.25	
Bluetooth	2402 - 2480 MHz	9.50	N/A		
Simultaneous SAR per KDB 690783 D01:			0.97	1.22	1.22

Note: Powers in the above table represent output powers for the SAR test configurations and may not represent the highest output powers for all configurations for each mode.

Note: This revised Test Report (S/N: 0Y1207050909-R1.ZNF) supersedes and replaces the previously issued test report on the same subject EUT for the same type of testing as indicated. Please discard or destroy the previously issued test report(s) and dispose of it accordingly.

This wireless portable device has been shown to be capable of compliance for localized specific absorption rate (SAR) for uncontrolled environment/general population exposure limits specified in ANSI/IEEE C95.1-1992 and has been tested in accordance with the measurement procedures specified in FCC/OET Bulletin 65 Supplement C (2001), IEEE 1528-2003 and in applicable Industry Canada Radio Standards Specifications (RSS); for North American frequency bands only.

I attest to the accuracy of data. All measurements reported herein were performed by me or were made under my supervision and are correct to the best of my knowledge and belief. I assume full responsibility for the completeness of these measurements and vouch for the qualifications of all persons taking them. Test results reported herein relate only to the item(s) tested.

PCTEST certifies that no party to this application has been subject to a denial of Federal benefits that includes FCC benefits pursuant to Section 5301 of the Anti-Drug Abuse Act of 1988, 21 U.S.C. 862.



Randy Ortanez
 President



FCC ID: ZNFE970		SAR EVALUATION REPORT		Reviewed by: Quality Manager
Document S/N: 0Y1207050909-R1.ZNF	Test Dates: 07/05/12 - 08/23/12	DUT Type: Portable Handset		Page 1 of 62

T A B L E O F C O N T E N T S

1	DEVICE UNDER TEST	3
2	LTE CHECKLIST PER KDB 941225 D05	8
3	INTRODUCTION.....	9
4	SAR MEASUREMENT SETUP	10
5	DOSIMETRIC ASSESSMENT	13
6	DEFINITION OF REFERENCE POINTS	14
7	TEST CONFIGURATION POSITIONS FOR HANDSETS	15
8	FCC RF EXPOSURE LIMITS.....	18
9	FCC MEASUREMENT PROCEDURES.....	19
10	RF CONDUCTED POWERS.....	23
11	SYSTEM VERIFICATION.....	33
12	SAR DATA SUMMARY	36
13	FCC MULTI-TX AND ANTENNA SAR CONSIDERATIONS.....	52
14	EQUIPMENT LIST.....	57
15	MEASUREMENT UNCERTAINTIES	58
16	CONCLUSION.....	60
17	REFERENCES	61

FCC ID: ZNFE970		SAR EVALUATION REPORT		Reviewed by: Quality Manager
Document S/N: 0Y1207050909-R1.ZNF	Test Dates: 07/05/12 - 08/23/12	DUT Type: Portable Handset	Page 2 of 62	

1 DEVICE UNDER TEST

1.1 Device Overview



Band & Mode	Tx Frequency
GSM/GPRS/EDGE 850	824.20 - 848.80 MHz
WCDMA/HSPA 850	826.40 - 846.60 MHz
GSM/GPRS/EDGE 1900	1850.20 - 1909.80 MHz
WCDMA/HSPA 1900	1852.4 - 1907.6 MHz
LTE Band 17	706.5 - 713.5 MHz
LTE Band 5 (Cell)	826.5 - 846.5 MHz
LTE Band 4 (AWS)	1712.5 - 1752.5 MHz
LTE Band 2 (PCS)	1852.5 - 1907.5 MHz
2.4 GHz WLAN	2412 - 2462 MHz
5.8 GHz WLAN	5745 - 5825 MHz
5.2 GHz WLAN	5180 - 5240 MHz
5.3 GHz WLAN	5260 - 5320 MHz
5.5 GHz WLAN	5500 - 5700 MHz
Bluetooth	2402 - 2480 MHz
NFC	13.56 MHz

1.2 Near Field Communications (NFC) Antenna

This DUT has NFC operations. The NFC antenna is integrated into the standard battery cover and will be the only battery cover available from the manufacturer for this model. Therefore all SAR tests were performed with the standard battery cover which already integrates the NFC antenna.

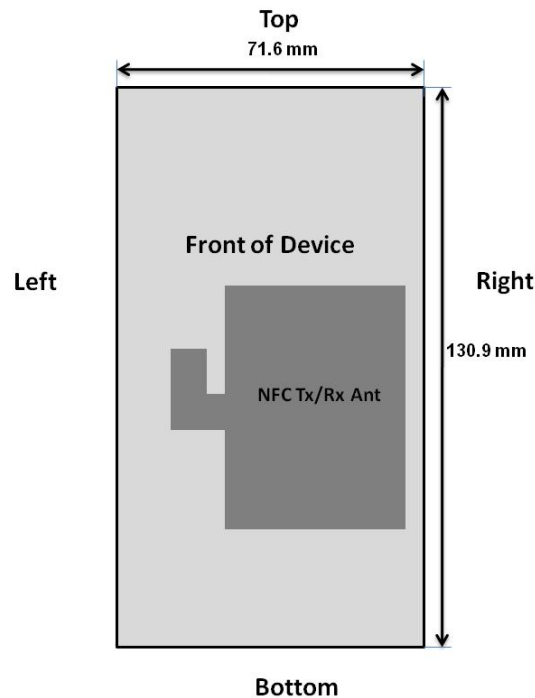
**Figure 1-1
NFC Antenna Locations**



FCC ID: ZNFE970	 PCTEST ENGINEERING LABORATORY, INC.	SAR EVALUATION REPORT	 LG	Reviewed by: Quality Manager
Document S/N: 0Y1207050909-R1.ZNF	Test Dates: 07/05/12 - 08/23/12	DUT Type: Portable Handset		Page 3 of 62

1.3 DUT Antenna Locations

**Figure 1-2
DUT Antenna Locations**

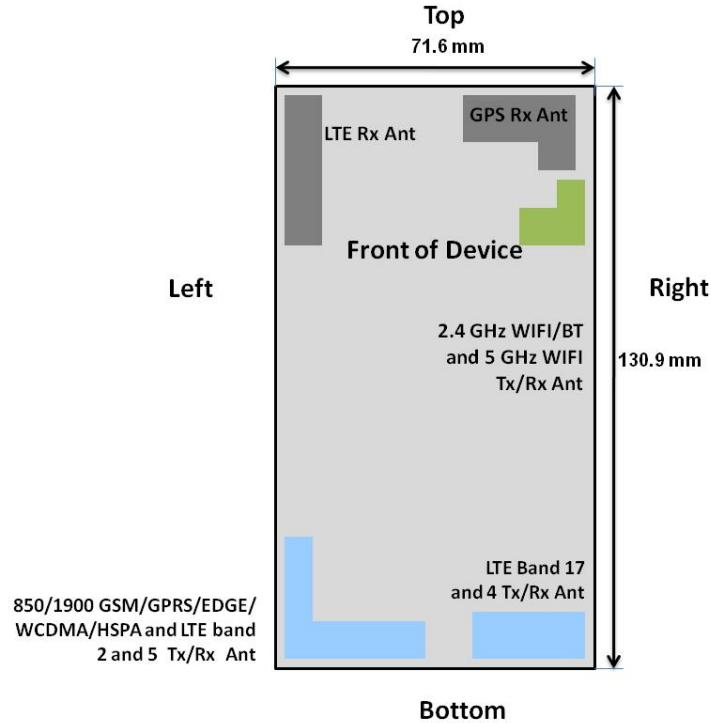

**Table 1-1
Mobile Hotspot Sides for SAR Testing**

Mobile Hotspot Sides for SAR Testing						
Mode	Back	Front	Top	Bottom	Right	Left
GPRS 850	Yes	Yes	No	Yes	No	Yes
WCDMA 850	Yes	Yes	No	Yes	No	Yes
GPRS 1900	Yes	Yes	No	Yes	No	Yes
WCDMA 1900	Yes	Yes	No	Yes	No	Yes
LTE Band 17	Yes	Yes	No	Yes	Yes	No
LTE Band 5 (Cell)	Yes	Yes	No	Yes	No	Yes
LTE Band 4 (AWS)	Yes	Yes	No	Yes	Yes	No
LTE Band 2 (PCS)	Yes	Yes	No	Yes	No	Yes
2.4 GHz WLAN	Yes	Yes	Yes	No	Yes	No

Note: Particular DUT edges were not required to be evaluated for Wireless Router SAR if the edges were greater than 2.5 cm from the transmitting antenna according to FCC KDB Publication 941225 D06 guidance, page 2. The antenna document shows the distances between the transmit antennas and the edges of the device. When the wireless router mode is enabled, all 5 GHz bands are disabled. Therefore 5 GHz WIFI is not considered in this section.

FCC ID: ZNFE970	PCTEST ENGINEERING LABORATORY, INC.	SAR EVALUATION REPORT		Reviewed by: Quality Manager
Document S/N: 0Y1207050909-R1.ZNF	Test Dates: 07/05/12 - 08/23/12	DUT Type: Portable Handset		Page 4 of 62

1.4 Simultaneous Transmission Capabilities

According to KDB 648474, transmitters are considered to be transmitting simultaneously when there is overlapping transmission, with the exception of transmissions during network hand-offs with maximum hand-off duration less than 30 seconds. Possible transmission paths for the DUT are shown in Figure 1-3 and are color-coded to indicate communication modes which share the same path. Modes which share the same transmission path cannot transmit simultaneously with one another.

The GSM/WCDMA and LTE BANDs 2 and 5 antenna and the LTE bands 4 and 17 antenna cannot transmit simultaneously since they share the same chip.



Figure 1-3
Simultaneous Transmission Paths

This device contains multiple transmitters that may operate simultaneously, and therefore requires a simultaneous transmission analysis according to KDB 447498 3) procedures.

Table 1-2
Simultaneous Transmission Scenarios

No.	Capable TX Configuration	Head SAR	Body Worn SAR	Hotspot SAR	Note
1	GSM 850 Voice + WiFi 2.4Ghz	Yes	Yes	N/A	GSM voice + WiFi 2.4Ghz
2	GSM 1900 Voice + WiFi 2.4Ghz	Yes	Yes	N/A	
3	GSM 850 Voice + WiFi 5Ghz	Yes	Yes	N/A	
4	GSM 1900 Voice + WiFi 5Ghz	Yes	Yes	N/A	GSM voice + WiFi 5Ghz
5	GSM 850 GPRS/EDGE + WiFi 2.4Ghz	Yes	Yes	Yes	
6	GSM 1900 GPRS/EDGE + WiFi 2.4Ghz	Yes	Yes	Yes	GSM GPRS/EDGE + WiFi 2.4Ghz
7	GSM 850 GPRS/EDGE + WiFi 5Ghz	No	No	No	
8	GSM 1900 GPRS/EDGE + WiFi 5Ghz	No	No	No	GSM GPRS/EDGE + WiFi 5Ghz
9	WCDMA 850 + WiFi 2.4Ghz	Yes	Yes	Yes	
10	WCDMA 1900 + WiFi 2.4Ghz	Yes	Yes	Yes	
11	WCDMA 850 + WiFi 5Ghz	Yes	Yes	No	WCDMA + WiFi 5Ghz
12	WCDMA 1900 + WiFi 5Ghz	Yes	Yes	No	
13	LTE B2 + WiFi 2.4Ghz	Yes	Yes	Yes	LTE + WiFi 2.4Ghz
14	LTE B4 + WiFi 2.4Ghz	Yes	Yes	Yes	
15	LTE B5 + WiFi 2.4Ghz	Yes	Yes	Yes	
16	LTE B17 + WiFi 2.4Ghz	Yes	Yes	Yes	
17	LTE B2 + WiFi 5Ghz	No	No	No	LTE + WiFi 5Ghz
18	LTE B4 + WiFi 5Ghz	No	No	No	
19	LTE B5 + WiFi 5Ghz	No	No	No	
20	LTE B17 + WiFi 5Ghz	No	No	No	

1. 2.4 GHz WiFi Hotspot is supported, 5GHz WiFi Hotspot is not supported.
2. LTE, WCDMA data, GPRS/EDGE Hotspot is supported.

FCC ID: ZNFE970	PCTEST ENGINEERING LABORATORY, INC.	SAR EVALUATION REPORT		Reviewed by: Quality Manager
Document S/N: 0Y1207050909-R1.ZNF	Test Dates: 07/05/12 - 08/23/12	DUT Type: Portable Handset		Page 5 of 62

1.5 SAR Test Exclusions Applied

(A) WIFI/BT

Since Wireless Router operations are not allowed by the chipset firmware using 5 GHz WIFI, only 2.4 GHz WIFI Hotspot SAR tests and combinations are considered for SAR with respect to Wireless Router configurations in KDB 941225 D06.

The separation between the GSM/WCDMA and LTE Band 2 and 5 antenna and the Bluetooth and WLAN antenna is 86.8 mm.

The separation between the LTE Band 4 and 17 antenna and the Bluetooth and WLAN antenna is 76.4 mm.

RF Conducted Power of Bluetooth Tx is 8.913 mW.

2.4 GHz and 5 GHz WIFI and Bluetooth share the same antenna path and cannot transmit simultaneously.

Per KDB Publication 648474, **Bluetooth SAR was not required** based on the maximum conducted power, the Bluetooth/WLAN to main antenna separation distance and Body-SAR of the main antenna.

(B) Licensed Transmitter(s)

This model does not support Simultaneous Voice and Data for the licensed transmitter in any modes except in WCDMA that allows Multi-RAB transmissions that share voice and data operations on a single physical channel.



GSM/GPRS/EDGE DTM is not supported. Therefore GSM Voice cannot transmit simultaneously with GPRS/EDGE Data.

Simultaneous Voice and LTE data ("SVLTE") cannot transmit simultaneously since they utilize the same transmission path as illustrated in **Figure 1-3**.

This device is only capable of QPSK HSUPA in the uplink, but is capable of HSPA+ in the downlink. Therefore, no additional SAR tests are required beyond that described for devices with HSUPA in KDB 941225 D01.

When the user utilizes multiple services in WCDMA 3G mode it uses multi-Radio Access Bearer or multi-RAB. The power control is based on a physical control channel (Dedicated Physical Control Channel [DPCCH]) and power control will be adjusted to meet the needs of both services. Therefore, the WCDMA+WLAN scenario also represents the WCDMA Voice/DATA + WLAN Hotspot scenario.

LTE SAR for the lower BWs was not tested since the maximum average output power of all channels and configurations was not more than 0.5 dB higher than the highest bandwidth; and LTE SAR for the highest BW was less than 1.45 W/kg for all configurations according to FCC KDB 941225 D05.

FCC ID: ZNFE970	 PCTEST ENGINEERING LABORATORY, INC.	SAR EVALUATION REPORT	 LG	Reviewed by: Quality Manager
Document S/N: 0Y1207050909-R1.ZNF	Test Dates: 07/05/12 - 08/23/12	DUT Type: Portable Handset		Page 6 of 62

1.6 Power Reduction for SAR

There is no power reduction for any band/mode implemented in this device for SAR purposes.



1.7 FCC Guidance Applied

- FCC OET Bulletin 65 Supplement C [June 2001]
- IEEE 1528-2003
- FCC KDB 941225 (2G/3G/4G and Hotspot)
- FCC KDB 248227 (802.11)
- FCC KDB 648474 (Simultaneous)
- FCC KDB 865664 (5 GHz)



1.8 Serial Numbers for SAR Testing

	Device SN used for Head Testing	Device SN used for Body-Worn/Hotspot Testing
GSM 850	2G/3G SAR#1	2G/3G SAR#1
GSM 1900	2G3G SAR#2	2G/3G SAR#1
WCDMA 850	2G/3G SAR#1	2G/3G SAR#1
WCDMA 1900	2G3G SAR#2	2G/3G SAR#1
LTE Band 17	LTE SAR #1	LTE SAR #1
LTE Band 5	LTE SAR #1	LTE SAR #1
LTE Band 4	LTE SAR #1	LTE SAR #1
LTE Band 2	LTE SAR #3	LTE SAR #3
2.4 GHz WLAN	WIFI SAR #1	WIFI SAR #1
5 GHz WLAN	WIFI SAR #1	WIFI SAR #1

The manufacturer has confirmed that the device(s) tested have the same physical, mechanical and thermal characteristics and are within operational tolerances expected for production units.

FCC ID: ZNFE970	 PCTEST ENGINEERING LABORATORY, INC.	SAR EVALUATION REPORT	 LG	Reviewed by: Quality Manager
Document S/N: 0Y1207050909-R1.ZNF	Test Dates: 07/05/12 - 08/23/12	DUT Type: Portable Handset		Page 7 of 62

KDB 941225 Pub LTE Information				
KDB 941225 Section	FCC ID	ZNFE970		
	Form Factor	Handset		
1)	Frequency Range of each LTE transmission band	Band 17: 706.5 - 713.5 MHz		
		Band 5: 826.5 - 846.6 MHz		
		Band 4: 1712.5 - 1752.5 MHz		
		Band 2: 1852.5 - 1907.5 MHz		
2)	Channel Bandwidths	Band 17: 5 MHz, 10 MHz		
		Band 5: 5 MHz, 10 MHz		
		Band 4: 5 MHz, 10 MHz		
		Band 2: 5 MHz, 10 MHz		
3)	Channel Numbers and Frequencies (MHz)	Low	Mid	High
	Band 17, 5 MHz BW	706.5 MHz (23755)	710 MHz (23790)	713.5 MHz (23825)
	Band 17, 10 MHz BW	709 MHz (23780)	710 MHz (23790)	711 MHz (23800)
	Band 5, 5 MHz BW	826.5 MHz (20425)	836.5 MHz (20525)	846.5 MHz (20625)
	Band 5, 10 MHz BW	829 MHz (20450)	836.5 MHz (20525)	844 MHz (20600)
	Band 4, 5 MHz BW	1712.5 MHz (19975)	1732.5 MHz (20175)	1752.5 MHz (20375)
	Band 4, 10 MHz BW	1715 MHz (20000)	1732.5 MHz (20175)	1750 MHz (20350)
	Band 2, 5 MHz BW	1852.5 MHz (18625)	1880 MHz (18900)	1907.5 MHz (19175)
	Band 2, 10 MHz BW	1855 MHz (18650)	1880 MHz (18900)	1905 MHz (19150)
4)(a)	UE Category	UE category 3		
(b)	Modulations Supported in UL	QPSK, 16QAM		
	LTE Transmitter and Antenna Implementation	This model(E970) has the same HW and two Tx antennas for GSM/WCDMA/LTE sharing one chip. For details, please refer to the antenna distance document and block diagram.		
5)	Description of LTE Tx and Ant. Implementation	1 TX/RX Ant for LTE Band 2 and 5, and 1 TX/RX Ant for LTE Band 4 and 17		
6)	LTE Voice available?	Yes		
	Hotspot with LTE+WIFI	Yes		
	Hotspot with LTE+WIFI active with Voice sessions?	No		
7)	LTE MPR Permanently implemented per 3GPP TS 36.101 section 6.2.3-6.2.5? (manufacturer attestation to be provided)	Yes		
	A-MPR (Additional MPR) disabled for SAR Testing?	Yes		
8)	Conducted power Table provided for 1RB (low and high offset), 50% RB (centered), 100% RB	Yes		
9-10)	Non-LTE US Wireless Operating Modes/Band	RF Output Power	RF Exposure Configurations	
	GSM/GPRS/EDGE 850	See page 1	Head, Body-Worn, and Hotspot	
	WCDMA/HSPA 850		Head, Body-Worn, and Hotspot	
	GSM/GPRS/EDGE 1900		Head, Body-Worn, and Hotspot	
	WCDMA/HSPA 1900		Head, Body-Worn, and Hotspot	
	Bluetooth		Body-Worn	
	2.4 GHz WLAN		Head, Body-Worn, and Hotspot	
	5 GHz WLAN		Head, Body-Worn	
11)	Simultaneous Tx Conditions (Voice and Data Configurations)		See section 1.4	
12)	Power Reduction used for SAR Compliance?	No		
13)	Describe Power Reduction (LTE Modes)	N/A		
14)	SAR Test Plan	N/A		
15)	SAR test data, preliminary	N/A		

FCC ID: ZNFE970	 PCTEST ENGINEERING LABORATORY, INC.	SAR EVALUATION REPORT	 LG	Reviewed by: Quality Manager
Document S/N: 0Y1207050909-R1.ZNF	Test Dates: 07/05/12 - 08/23/12	DUT Type: Portable Handset	Page 8 of 62	

3 INTRODUCTION

The FCC has adopted the guidelines for evaluating the environmental effects of radio frequency (RF) radiation in ET Docket 93-62 on Aug. 6, 1996 to protect the public and workers from the potential hazards of RF emissions due to FCC-regulated portable devices. [1]

The safety limits used for the environmental evaluation measurements are based on the criteria published by the American National Standards Institute (ANSI) for localized specific absorption rate (SAR) in IEEE/ANSI C95.1-1992 Standard for Safety Levels with Respect to Human Exposure to Radio Frequency Electromagnetic Fields, 3 kHz to 300 GHz [3] and Health Canada RF Exposure Guidelines Safety Code 6 [24]. The measurement procedure described in IEEE/ANSI C95.3-2002 Recommended Practice for the Measurement of Potentially Hazardous Electromagnetic Fields - RF and Microwave [4] is used for guidance in measuring the Specific Absorption Rate (SAR) due to the RF radiation exposure from the Equipment Under Test (EUT). These criteria for SAR evaluation are similar to those recommended by the International Committee for Non-Ionizing Radiation Protection (ICNIRP) in Biological Effects and Exposure Criteria for Radiofrequency Electromagnetic Fields," Report No. Vol 74. SAR is a measure of the rate of energy absorption due to exposure to an RF transmitting source. SAR values have been related to threshold levels for potential biological hazards.

3.1 SAR Definition

Specific Absorption Rate is defined as the time derivative (rate) of the incremental energy (dU) absorbed by (dissipated in) an incremental mass (dm) contained in a volume element (dV) of a given density (ρ). It is also defined as the rate of RF energy absorption per unit mass at a point in an absorbing body (see Equation 3-1).

Equation 3-1
SAR Mathematical Equation

$$SAR = \frac{d}{dt} \left(\frac{dU}{dm} \right) = \frac{d}{dt} \left(\frac{dU}{\rho dv} \right)$$



SAR is expressed in units of Watts per Kilogram (W/kg).

$$SAR = \frac{\sigma \cdot E^2}{\rho}$$

where:

- σ = conductivity of the tissue-simulating material (S/m)
- ρ = mass density of the tissue-simulating material (kg/m^3)
- E = Total RMS electric field strength (V/m)

NOTE: The primary factors that control rate of energy absorption were found to be the wavelength of the incident field in relation to the dimensions and geometry of the irradiated organism, the orientation of the organism in relation to the polarity of field vectors, the presence of reflecting surfaces, and whether conductive contact is made by the organism with a ground plane.[6]

FCC ID: ZNFE970	 PCTEST ENGINEERING LABORATORY, INC.	SAR EVALUATION REPORT	 LG	Reviewed by: Quality Manager
Document S/N: 0Y1207050909-R1.ZNF	Test Dates: 07/05/12 - 08/23/12	DUT Type: Portable Handset		Page 9 of 62

4 SAR MEASUREMENT SETUP

4.1 Automated SAR Measurement System

Measurements are performed using the DASY automated dosimetric SAR assessment system. The DASY is made by Schmid & Partner Engineering AG (SPEAG) in Zurich, Switzerland and consists of a high precision robotics system (Staubli), robot controller, desktop computer, near-field probe, probe alignment sensor, and the SAM phantom containing the head or body equivalent material. The robot is a six-axis industrial robot, performing precise movements to position the probe to the location (points) of maximum electromagnetic field (EMF). See www.speag.com for more information about the specification of the SAR assessment system.



Figure 4-1
SAR Measurement System





Figure 4-2
Near-Field Probe

Table 4-1
Composition of the Tissue Equivalent Matter

Frequency (MHz)	835	835	1750	1750	1900	1900	2450	2450	5200-5800	5200-5800
Tissue	Head	Body	Head	Body	Head	Body	Head	Body	Head	Body
Ingredients (% by weight)										
Bactericide	0.1	0.1								
DGBE			47	31	44.92	29.44	7.99	26.7		
HEC	1	1								
NaCl	1.45	0.94	0.4	0.2	0.18	0.39	0.16	0.1		
Sucrose	57	44.9								
Triton X-100							19.97		17.24	
Diethylenglycol monohexylether									17.24	
Polysorbate (Tween) 80										20
Water	40.45	53.06	52.6	68.8	54.9	70.17	71.88	73.2	65.52	80

See next page for 750 MHz Tissue Composition

FCC ID: ZNFE970		SAR EVALUATION REPORT		Reviewed by: Quality Manager
Document S/N: 0Y1207050909-R1.ZNF	Test Dates: 07/05/12 - 08/23/12	DUT Type: Portable Handset		Page 10 of 62

**Table 4-2
Composition of 750 MHz Head and Body Tissue Equivalent Matter**

2 Composition / Information on ingredients	
The Item is composed of the following ingredients:	
H ₂ O	Water, 35 – 58%
Sucrose	Sugar, white, refined, 40 – 80%
NaCl	Sodium Chloride, 0 – 6%
Hydroxyethyl-cellulose	Medium Viscosity (CAS# 9004-82-0), <0.3%
Preventol-D7	Preservative: aqueous preparation, (CAS# 55965-84-9), containing 5-chloro-2-methyl-3(2H)-isothiazolone and 2-methyl-3(2H)-isothiazolone, 0.1 – 0.7%
Relevant for safety; Refer to the respective Safety Data Sheet*.	

Note: 750MHz liquid recipes are proprietary SPEAG. Since the composition is approximate to the actual liquids utilized, the manufacturer tissue-equivalent liquid data sheets are provided below.

Measurement Certificate / Material Test

Item Name	Body Tissue Simulating Liquid (MSL 750)
Product No.	SL AAM 075 AA (Charge: 110606-1)
Manufacturer	SPEAG

Measurement Method

TSL dielectric parameters measured using calibrated OCP probe (type DAK).

Target Parameters

Target parameters as defined in the IEEE 1528 and IEC 62209 compliance standards.

Test Condition

Ambient Condition 22°C ; 30% humidity
TSL Temperature 22°C
Test Date 8-Jun-11

Additional information

TSL Density 1.212 g/cm³
TSL Heat-capacity 3.006 kJ/(kg*K)

Results

f (MHz)	Measured			Target		Diff. to Target (%)	
	HP-e'	HP-e''	sigma	eps	sigma	Δ-eps	Δ-sigma
600	57.4	24.88	0.83	56.1	0.95	2.4	-12.7
625	57.2	24.53	0.85	56.0	0.95	2.1	-10.6
650	57.0	24.18	0.87	55.9	0.95	1.8	-8.5
675	56.7	23.90	0.90	55.8	0.95	1.5	-6.3
700	56.4	23.61	0.92	55.7	0.95	1.2	-4.2
725	56.2	23.37	0.94	55.6	0.95	0.9	-2.0
750	55.9	23.12	0.96	55.5	0.96	0.7	0.1
775	55.7	22.95	0.99	55.4	0.97	0.4	2.5
800	55.4	22.78	1.01	55.3	0.97	0.1	4.8
825	55.2	22.61	1.04	55.2	0.98	-0.2	6.1
838	55.0	22.52	1.05	55.2	0.98	-0.3	6.7
850	54.9	22.44	1.06	55.2	0.99	-0.4	7.3
875	54.7	22.30	1.09	55.1	1.02	-0.7	6.5
900	54.5	22.17	1.11	55.0	1.05	-1.0	5.7
925	54.2	22.05	1.13	55.0	1.06	-1.3	6.8
950	54.0	21.94	1.16	54.9	1.08	-1.7	7.8
975	53.8	21.85	1.18	54.9	1.09	-2.0	9.0
1000	53.6	21.75	1.21	54.8	1.10	-2.3	10.2

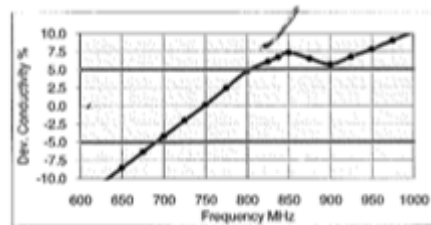
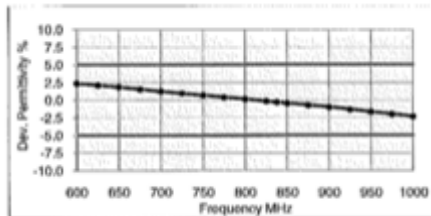

**Figure 4-3
750MHz Body Tissue Equivalent Matter**

FCC ID: ZNFE970	PCTEST Engineering Laboratory, Inc.	SAR EVALUATION REPORT	LG	Reviewed by: Quality Manager
Document S/N: OY1207050909-R1.ZNF	Test Dates: 07/05/12 - 08/23/12	DUT Type: Portable Handset		Page 11 of 62

Measurement Certificate / Material Test

Item Name **Head Tissue Simulating Liquid (HSL 750)**
 Product No. SL AAH 075 (Charge: 110601-1)
 Manufacturer SPEAG

Measurement Method
 TSL dielectric parameters measured using calibrated OCP probe (type DAK).

Target Parameters
 Target parameters as defined in the IEEE 1528 and IEC 62209 compliance standards.

Test Condition
 Ambient Condition 22°C ; 30% humidity
 TSL Temperature 22°C
 Test Date 8-Jun-11

Additional Information
 TSL Density 1.284 g/cm³
 TSL Heat-capacity 2.701 kJ/(kg*K)

Results

f (MHz)	Measured			Target		Diff.to Target (%)	
	HP-e'	HP-e''	sigma	eps	sigma	Δ-eps	Δ-sigma
600	43.9	23.01	0.77	42.7	0.88	2.7	-12.9
625	43.5	22.75	0.79	42.6	0.88	2.1	-10.5
650	43.1	22.49	0.81	42.5	0.89	1.5	-8.2
675	42.7	22.26	0.84	42.3	0.89	1.0	-5.9
700	42.4	22.03	0.86	42.2	0.89	0.4	-3.5
725	42.0	21.84	0.88	42.1	0.89	-0.1	-1.2
750	41.7	21.65	0.90	41.9	0.89	-0.6	1.1
775	41.4	21.50	0.93	41.8	0.90	-1.1	3.5
800	41.0	21.34	0.95	41.7	0.90	-1.6	5.9
825	40.7	21.19	0.97	41.6	0.91	-2.1	7.3
850	40.5	21.12	0.98	41.5	0.91	-2.4	8.0
875	40.4	21.05	1.00	41.5	0.92	-2.7	8.6
900	40.1	20.91	1.02	41.5	0.94	-3.3	7.9
925	39.8	20.77	1.04	41.5	0.97	-4.0	7.2
950	39.6	20.66	1.06	41.5	0.98	-4.6	8.2
975	39.3	20.55	1.09	41.4	0.99	-5.2	9.2
1000	39.0	20.44	1.11	41.4	1.00	-5.8	10.3
1000	38.7	20.32	1.13	41.3	1.01	-6.4	11.4

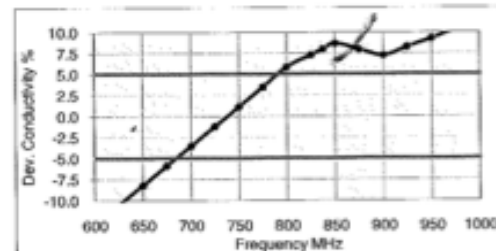
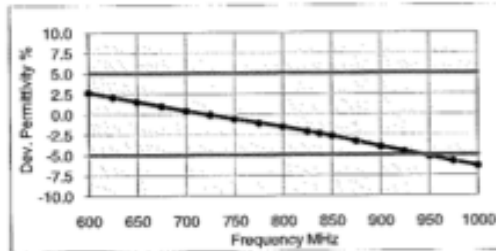

Figure 4-4
750MHz Head Tissue Equivalent Matter

FCC ID: ZNFE970	PCTEST Engineering Laboratory, Inc.	SAR EVALUATION REPORT	LG	Reviewed by: Quality Manager
Document S/N: OY1207050909-R1.ZNF	Test Dates: 07/05/12 - 08/23/12	DUT Type: Portable Handset		Page 12 of 62

5 DOSIMETRIC ASSESSMENT

5.1 Measurement Procedure

The evaluation was performed using the following procedure:

1. The SAR distribution at the exposed side of the head or body was measured at a distance no greater than 5.0 mm from the inner surface of the shell. The area covered the entire dimension of the device-head interface and the horizontal grid resolution was 15mm and 15mm for frequencies < 3 GHz in the x and y directions respectively. When applicable, for frequencies above 3 GHz, a 10 mm by 10 mm resolution was used.
2. The point SAR measurement was taken at the maximum SAR region determined from Step 1 to enable the monitoring of SAR fluctuations/drifts during the 1 gram cube evaluation. SAR at this fixed point was measured and used as a reference value.
3. Based on the area scan data, the peak area of the maximum absorption was determined by spline interpolation. Around this point, a volume of 32mm x 32mm x 30mm (fine resolution volume scan, zoom scan) was assessed by measuring at least 5 x 5 x 7 points. On this basis of this data set, the spatial peak SAR value was evaluated with the following procedure (see references or the DASY manual online for more details):
 - a. The data was extrapolated to the surface of the outer-shell of the phantom. The combined distance extrapolated was the combined distance from the center of the dipoles 2.7mm away from the tip of the probe housing plus the 1.2 mm distance between the surface and the lowest measuring point. The extrapolation was based on a least-squares algorithm. A polynomial of the fourth order was calculated through the points in the z-axis (normal to the phantom shell).
 - b. After the maximum interpolated values were calculated between the points in the cube, the SAR was averaged over the spatial volume (1g or 10g) using a 3D-Spline interpolation algorithm. The 3D-spline is composed of three one-dimensional splines with the “Not a knot” condition (in x, y, and z directions). The volume was then integrated with the trapezoidal algorithm. One thousand points (10 x 10 x 10) were obtained through interpolation, in order to calculate the averaged SAR.
 - c. All neighboring volumes were evaluated until no neighboring volume with a higher average value was found.
4. The SAR reference value, at the same location as step 2, was re-measured after the zoom scan was complete to calculate the SAR drift. If the drift deviated by more than 5%, the SAR test and drift measurements were repeated.
5. For testing 5 GHz devices, finer resolution zoom scans were performed as specified by FCC SAR Measurement Requirements for 3 – 6 GHz, KDB 865664 publication. The 5 GHz zoom scan requires a minimum volume of 24mm x 24mm x 20mm and 7 x 7 x 11 points.

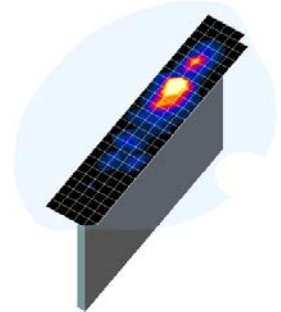



Figure 5-1
Sample SAR Area Scan

FCC ID: ZNFE970	 PCTEST ENGINEERING LABORATORY, INC.	SAR EVALUATION REPORT	 LG	Reviewed by: Quality Manager
Document S/N: 0Y1207050909-R1.ZNF	Test Dates: 07/05/12 - 08/23/12	DUT Type: Portable Handset		Page 13 of 62

6

DEFINITION OF REFERENCE POINTS

6.1 EAR REFERENCE POINT

Figure 6-2 shows the front, back and side views of the SAM Twin Phantom. The point “M” is the reference point for the center of the mouth, “LE” is the left ear reference point (ERP), and “RE” is the right ERP. The ERP is 15mm posterior to the entrance to the ear canal (EEC) along the B-M line (Back-Mouth), as shown in Figure 6-1. The plane passing through the two ear canals and M is defined as the Reference Plane. The line N-F (Neck-Front) is perpendicular to the reference plane and passing through the RE (or LE) is called the Reference Pivoting Line (see Figure 6-2). Line B-M is perpendicular to the N-F line. Both N-F and B-M lines are marked on the external phantom shell to facilitate handset positioning [5].

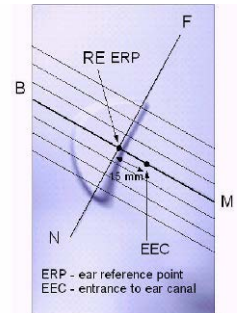

Figure 6-1
Close-Up Side view
of ERP

6.2 HANDSET REFERENCE POINTS

Two imaginary lines on the handset were established: the vertical centerline and the horizontal line. The test device was placed in a normal operating position with the “test device reference point” located along the “vertical centerline” on the front of the device aligned to the “ear reference point” (See Figure 6-3). The “test device reference point” was then located at the same level as the center of the ear reference point. The test device was positioned so that the “vertical centerline” was bisecting the front surface of the handset at it’s top and bottom edges, positioning the “ear reference point” on the outer surface of the both the left and right head phantoms on the ear reference point.



Figure 6-2
Front, back and side view of SAM Twin Phantom

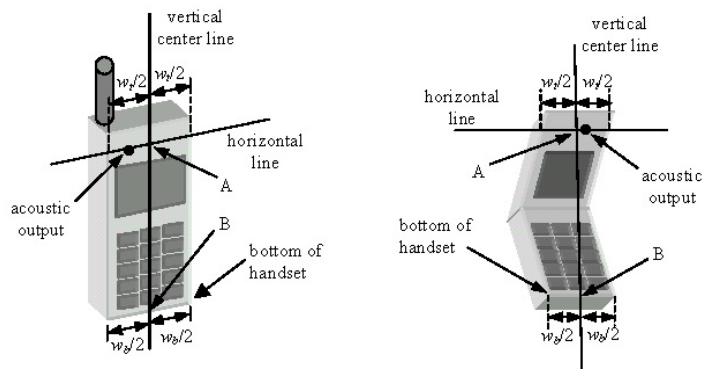

Figure 6-3
Handset Vertical Center & Horizontal Line Reference Points

FCC ID: ZNFE970	PCTEST ENGINEERING LABORATORY, INC.	SAR EVALUATION REPORT	LG	Reviewed by: Quality Manager
Document S/N: 0Y1207050909-R1.ZNF	Test Dates: 07/05/12 - 08/23/12	DUT Type: Portable Handset		Page 14 of 62

7 TEST CONFIGURATION POSITIONS FOR HANDSETS

7.1 Device Holder

The DASY device holder has been made out of low-loss POM material having the following dielectric parameters: relative permittivity $\epsilon = 3$ and loss tangent $\delta = 0.02$.

7.2 Positioning for Cheek/Touch

1. The test device was positioned with the handset close to the surface of the phantom such that point A is on the (virtual) extension of the line passing through points RE and LE on the phantom (see Figure 7-1), such that the plane defined by the vertical center line and the horizontal line of the phone is approximately parallel to the sagittal plane of the phantom.

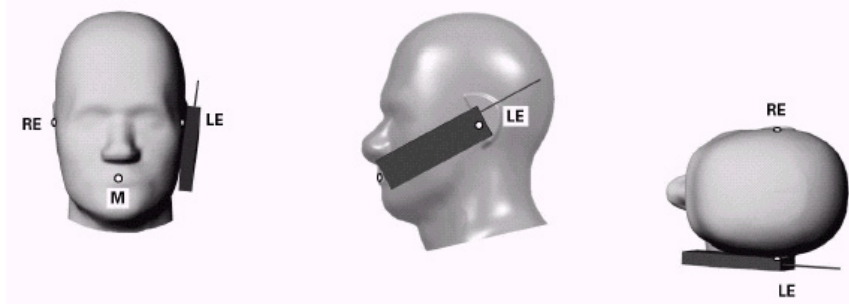



Figure 7-1 Front, Side and Top View of Cheek/Touch Position

2. The handset was translated towards the phantom along the line passing through RE & LE until the handset touches the ear.
3. While maintaining the handset in this plane, the handset was rotated around the LE-RE line until the vertical centerline was in the plane normal to MB-NF including the line MB (reference plane).
4. The phone was then rotated around the vertical centerline until the phone (horizontal line) was symmetrical with respect to the line NF.
5. While maintaining the vertical centerline in the reference plane, keeping point A on the line passing through RE and LE, and maintaining the phone contact with the ear, the handset was rotated about the line NF until any point on the handset made contact with a phantom point below the ear (cheek) (See Figure 7-2).

7.3 Positioning for Ear / 15° Tilt

With the test device aligned in the “Cheek/Touch Position”:

1. While maintaining the orientation of the phone, the phone was retracted parallel to the reference plane far enough to enable a rotation of the phone by 15degree.
2. The phone was then rotated around the horizontal line by 15 degree.
3. While maintaining the orientation of the phone, the phone was moved parallel to the reference plane until any part of the phone touches the head. (In this position, point A was located on the line RE-LE). The tilted position is obtained when the contact is on the pinna. If the contact was at any location other than the pinna, the angle of the phone would then be reduced. The tilted position was obtained when any part of the phone was in contact of the ear as well as a second part of the phone was in contact with the head (see Figure 7-2).

FCC ID: ZNFE970		SAR EVALUATION REPORT		Reviewed by: Quality Manager
Document S/N: 0Y1207050909-R1.ZNF	Test Dates: 07/05/12 - 08/23/12	DUT Type: Portable Handset		Page 15 of 62

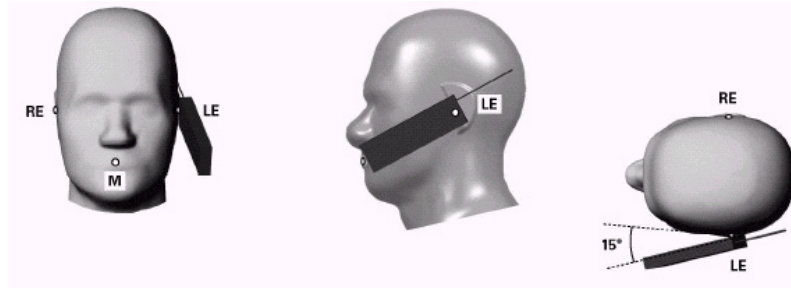

Figure 7-2 Front, Side and Top View of Ear/15° Tilt Position

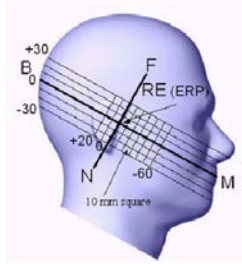

Figure 7-3 Side view w/ relevant markings



Figure 7-4 Body SAR Sample Photo (Not Actual EUT)

7.4 SAR Evaluations near the Mouth/Jaw Regions of the SAM Phantom

Antennas located near the bottom of a phone may require SAR measurements around the mouth and jaw regions of the SAM head phantom. This typically applies to clam-shell style phones that are generally longer in the unfolded normal use positions or to certain older style long rectangular phones.

Under these circumstances, the following procedures apply, adopted from the FCC guidance on SAR handsets document publication 648474. The SAR required in these regions of SAM should be measured using a flat phantom. **Rectangular shaped phones** should be positioned with its bottom edge positioned from the flat phantom with the same distance provided by the cheek touching position using SAM. The ear reference point (ERP, as defined for SAM) of the phone should be positioned ½ cm from the flat phantom shell. **Clam-shell phones** should be positioned with the hinge against a smooth edge of the flat phantom where the upper half of the phone is unfolded and extended beyond the phantom side wall. The lower half of the phone is secured in the test device holder at a fixed distance below the flat phantom determined by the minimum separation along the lower edge of the phone in the cheek touching position using SAM. Any case with substantial variation in separation distance along the lower edge of a clam shell is discussed with the FCC for best-to-use methodology.

The latest IEEE 1528 committee developments propose the usage of a tilted phantom when the antenna of the phone is mounted at the bottom or in all cases the peak absorption is in the chin region. Both SAM heads of the TwinSAM-Chin20 are rotated 20 degrees around the NF line. Each head can be removed individually from the table for emptying and cleaning.

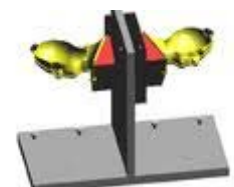

Figure 7-5 Twin SAM Chin20

7.5 Body-Worn Accessory Configurations

Body-worn operating configurations are tested with the belt-clips and holsters attached to the device and positioned against a flat phantom in a normal use configuration (see Figure 7-4). A device with a headset output is tested with a headset connected to the device.

FCC ID: ZNFE970	PCTEST ENGINEERING LABORATORY, INC.	SAR EVALUATION REPORT	LG	Reviewed by: Quality Manager
Document S/N: 0Y1207050909-R1.ZNF	Test Dates: 07/05/12 - 08/23/12	DUT Type: Portable Handset		Page 16 of 62



Accessories for Body-worn operation configurations are divided into two categories: those that do not contain metallic components and those that do contain metallic components. When multiple accessories that do not contain metallic components are supplied with the device, the device is tested with only the accessory that dictates the closest spacing to the body. Then multiple accessories that contain metallic components are tested with the device with each accessory. If multiple accessories share an identical metallic component (i.e. the same metallic belt-clip used with different holsters with no other metallic components) only the accessory that dictates the closest spacing to the body is tested.

Body-worn accessories may not always be supplied or available as options for some devices intended to be authorized for body-worn use. In this case, a test configuration with a separation distance between the back of the device and the flat phantom is used. Test position spacing was documented. Transmitters that are designed to operate in front of a person's face, as in push-to-talk configurations, are tested for SAR compliance with the front of the device positioned to face the flat phantom in head fluid. For devices that are carried next to the body such as a shoulder, waist or chest-worn transmitters, SAR compliance is tested with the accessories, including headsets and microphones, attached to the device and positioned against a flat phantom in a normal use configuration.

7.6 Wireless Router Configurations

Some battery-operated handsets have the capability to transmit and receive internet connectivity through simultaneous transmission of WIFI in conjunction with a separate licensed transmitter. The FCC has provided guidance in KDB Publication 941225 D06 where SAR test considerations for handsets ($L \times W \geq 9 \text{ cm} \times 5 \text{ cm}$) are based on a composite test separation distance of 10 mm from the front, back and edges of the device with antennas 2.5 cm or closer to the edge of the device, determined from general mixed use conditions for this type of devices. Since the hotspot SAR results may overlap with the body-worn accessory SAR requirements, the more conservative configurations can be considered, thus excluding some body-worn accessory SAR tests.

When the user enables the personal wireless router functions for the handset, actual operations include simultaneous transmission of both the WIFI transmitter and another licensed transmitter. Both transmitters often do not transmit at the same transmitting frequency and thus cannot be evaluated for SAR under actual use conditions. Therefore, SAR must be evaluated for each frequency transmission and mode separately and summed with the WIFI transmitter according to KDB 648474 publication procedures. The "Portable Hotspot" feature on the handset was NOT activated, to ensure the SAR measurements were evaluated for a single transmission frequency RF signal.

FCC ID: ZNFE970	 PCTEST ENGINEERING LABORATORY, INC.	SAR EVALUATION REPORT	 LG	Reviewed by: Quality Manager
Document S/N: 0Y1207050909-R1.ZNF	Test Dates: 07/05/12 - 08/23/12	DUT Type: Portable Handset		Page 17 of 62

8 FCC RF EXPOSURE LIMITS

8.1 Uncontrolled Environment

UNCONTROLLED ENVIRONMENTS are defined as locations where there is the exposure of individuals who have no knowledge or control of their exposure. The general population/uncontrolled exposure limits are applicable to situations in which the general public may be exposed or in which persons who are exposed as a consequence of their employment may not be made fully aware of the potential for exposure or cannot exercise control over their exposure. Members of the general public would come under this category when exposure is not employment-related; for example, in the case of a wireless transmitter that exposes persons in its vicinity.



8.2 Controlled Environment

CONTROLLED ENVIRONMENTS are defined as locations where there is exposure that may be incurred by persons who are aware of the potential for exposure, (i.e. as a result of employment or occupation). In general, occupational/controlled exposure limits are applicable to situations in which persons are exposed as a consequence of their employment, who have been made fully aware of the potential for exposure and can exercise control over their exposure. This exposure category is also applicable when the exposure is of a transient nature due to incidental passage through a location where the exposure levels may be higher than the general population/uncontrolled limits, but the exposed person is fully aware of the potential for exposure and can exercise control over his or her exposure by leaving the area or by some other appropriate means.

Table 8-1
SAR Human Exposure Specified in ANSI/IEEE C95.1-1992 and Health Canada Safety Code 6

HUMAN EXPOSURE LIMITS		
	UNCONTROLLED ENVIRONMENT <i>General Population</i> (W/kg) or (mW/g)	CONTROLLED ENVIRONMENT <i>Occupational</i> (W/kg) or (mW/g)
SPATIAL PEAK SAR Brain	1.6	8.0
SPATIAL AVERAGE SAR Whole Body	0.08	0.4
SPATIAL PEAK SAR Hands, Feet, Ankles, Wrists	4.0	20

1. The Spatial Peak value of the SAR averaged over any 1 gram of tissue (defined as a tissue volume in the shape of a cube) and over the appropriate averaging time.
2. The Spatial Average value of the SAR averaged over the whole body.
3. The Spatial Peak value of the SAR averaged over any 10 grams of tissue (defined as a tissue volume in the shape of a cube) and over the appropriate averaging time.

FCC ID: ZNFE970	 PCTEST ENGINEERING LABORATORY, INC.	SAR EVALUATION REPORT	 LG	Reviewed by: Quality Manager
Document S/N: 0Y1207050909-R1.ZNF	Test Dates: 07/05/12 - 08/23/12	DUT Type: Portable Handset		Page 18 of 62

Power measurements were performed using a base station simulator under digital average power.

9.1 Procedures Used to Establish RF Signal for SAR

The following procedures are according to FCC KDB Publication 941225 D01 "SAR Measurement Procedures for 3G Devices" v02, October 2007.

The device was placed into a simulated call using a base station simulator in a RF shielded chamber. Establishing connections in this manner ensure a consistent means for testing SAR and are recommended for evaluating SAR [4]. Devices under test were evaluated prior to testing, with a fully charged battery and were configured to operate at maximum output power. In order to verify that the device was tested throughout the SAR test at maximum output power, the SAR measurement system measures a "point SAR" at an arbitrary reference point at the start and end of the 1 gram SAR evaluation, to assess for any power drifts during the evaluation. If the power drift deviated by more than 5%, the SAR test and drift measurements were repeated.

9.2 SAR Measurement Conditions for WCDMA

9.2.1 Output Power Verification

Maximum output power is measured on the High, Middle and Low channels for each applicable transmission band according to the general descriptions in section 5.2 of 3GPP TS 34.121, using the appropriate RMC or AMR with TPC (transmit power control) set to all "1s".

9.2.2 Head SAR Measurements for Handsets



SAR for head exposure configurations is measured using the 12.2 kbps RMC with TPC bits configured to all "1s". SAR in AMR configurations is not required when the maximum average output of each RF channel for 12.2 kbps AMR is less than 0.25 dB higher than that measured in 12.2 kbps RMC. Otherwise, SAR is measured on the maximum output channel in 12.2 AMR with a 3.4 kbps SRB (signaling radio bearer) using the exposure configuration that resulted in the highest SAR for that RF channel in the 12.2 kbps RMC mode.

9.2.3 Body SAR Measurements

SAR for body exposure configurations is measured using the 12.2 kbps RMC with the TPC bits all "1s".

9.2.4 SAR Measurements for Handsets with Rel 5 HSDPA

Body SAR for HSDPA is not required for handsets with HSDPA capabilities when the maximum average output power of each RF channel with HSDPA active is less than 0.25 dB higher than that measured without HSDPA using 12.2 kbps RMC and the maximum SAR for 12.2 kbps RMC is $\leq 75\%$ of the SAR limit. Otherwise, SAR is measured for HSDPA, using an FRC with H-Set 1 in Sub-test 1 and a 12.2 kbps RMC configured in Test Loop Mode 1, using the highest body SAR configuration measured in 12.2 kbps RMC without HSDPA, on the maximum output channel with the body exposure configuration that resulted in the highest SAR in 12.2 kbps RMC mode for that RF channel.

FCC ID: ZNFE970	 PCTEST ENGINEERING LABORATORY, INC.	SAR EVALUATION REPORT	 LG	Reviewed by: Quality Manager
Document S/N: 0Y1207050909-R1.ZNF	Test Dates: 07/05/12 - 08/23/12	DUT Type: Portable Handset		Page 19 of 62

The H-set used in FRC for HSDPA should be configured according to the UE category of a test device. The number of HS-DSCH/HSPDSCHs, HARQ processes, minimum inter-TTI interval, transport block sizes and RV coding sequence are defined by the applicable H-set. To maintain a consistent test configuration and stable transmission conditions, QPSK is used in the FRC for SAR testing. HS-DPCCH should be configured with a CQI feedback cycle of 2 ms to maintain a constant rate of active CQI slots. DPCCH and DPDCH gain factors of $\beta_c=9$ and $\beta_d=15$, and power offset parameters of $\Delta_{ACK} = \Delta_{NACK} = 5$ and $\Delta_{CQI}=2$ is used. The CQI value is determined by the UE category, transport block size, number of HS-PDSCHs and modulation used in the FRC.

9.2.5 SAR Measurements for Handsets with Rel 6 HSUPA

Body SAR for HSUPA is not required when the maximum average output of each RF channel with HSUPA/HSDPA active is less than 0.25 dB higher than as measured without HSUPA/HSDPA using 12.2 kbps RMC and maximum SAR for 12.2 kbps RMC is $\leq 75\%$ of the SAR limit. Otherwise SAR is measured on the maximum output channel for the body exposure configuration produced highest SAR in 12.2 kbps RMC for that RF channel, using the additional procedures under “Release 6 HSPA data devices”

Head SAR for VOIP operations under HSPA is not required when maximum average output of each RF channel with HSPA is less than 0.25 dB higher than as measured using 12.2 kbps RMC. Otherwise SAR is measured using same HSPA configuration as used for body SAR.

Sub-test	β_c	β_d	β_d (SF)	β_c/β_d	β_{15} ⁽¹⁾	β_{ec}	β_{ed}	β_{ed} (SF)	β_{ed} (codes)	CM ⁽²⁾ (dB)	MPR (dB)	AG ⁽⁴⁾ Index	E-TFCI
1	11/15 ⁽³⁾	15/15 ⁽³⁾	64	11/15 ⁽³⁾	22/15	209/225	1039/225	4	1	1.0	0.0	20	75
2	6/15	15/15	64	6/15	12/15	12/15	94/75	4	1	3.0	2.0	12	67
3	15/15	9/15	64	15/9	30/15	30/15	$\beta_{d1}: 47/15$ $\beta_{d2}: 47/15$	4	2	2.0	1.0	15	92
4	2/15	15/15	64	2/15	4/15	2/15	56/75	4	1	3.0	2.0	17	71
5	15/15 ⁽⁴⁾	15/15 ⁽⁴⁾	64	15/15 ⁽⁴⁾	30/15	24/15	134/15	4	1	1.0	0.0	21	81



Note 1: $\Delta_{ACK}, \Delta_{NACK}$ and $\Delta_{CQI} = 8 \Leftrightarrow A_{15} = \beta_{15}/\beta_c = 30/15 \Leftrightarrow \beta_{15} = 30/15 * \beta_c$.
 Note 2: CM = 1 for $\beta_c/\beta_d = 12/15, \beta_{15}/\beta_c = 24/15$. For all other combinations of DPDCH, DPCCH, HS-DPCCH, E-DPDCH and E-DPCCH the MPR is based on the relative CM difference.
 Note 3: For subtest 1 the β_c/β_d ratio of 11/15 for the TFC during the measurement period (TF1, TF0) is achieved by setting the signaled gain factors for the reference TFC (TF1, TF1) to $\beta_c = 10/15$ and $\beta_d = 15/15$.
 Note 4: For subtest 5 the β_c/β_d ratio of 15/15 for the TFC during the measurement period (TF1, TF0) is achieved by setting the signaled gain factors for the reference TFC (TF1, TF1) to $\beta_c = 14/15$ and $\beta_d = 15/15$.
 Note 5: Testing UE using E-DPDCH Physical Layer category 1 Sub-test 3 is not required according to TS 25.306 Table 5.1g.
 Note 6: β_{ed} can not be set directly; it is set by Absolute Grant Value.

9.3 SAR Measurement Conditions for LTE

LTE modes were tested according to FCC KDB 941225 D05 publication. Please see notes following SAR data for required test configurations. Establishing connections with base station simulators ensure a consistent means for testing SAR and are recommended for evaluating SAR [4]. The R&S CMW500 was used for LTE output power measurements and SAR testing. Closed loop power control was used so the UE transmits with maximum output power during SAR testing.

9.3.1 MPR

MPR is permanently implemented for this device by the manufacturer. The specific manufacturer target MPR is indicated alongside the SAR results. MPR is enabled for this device, according to 3GPP TS36.101 Section 6.2.3 – 6.2.5 under Table 6.2.3-1. The differences noted are not cases of implemented MPR but rather associated with measurement uncertainty and allowable tolerances per 3GPP standard and the manufacturer. See Section 0 for MPR targets.

FCC ID: ZNFE970	 PCTEST Engineering Laboratory, Inc.	SAR EVALUATION REPORT	 LG	Reviewed by: Quality Manager
Document S/N: 0Y1207050909-R1.ZNF	Test Dates: 07/05/12 - 08/23/12	DUT Type: Portable Handset		Page 20 of 62

9.3.2 A-MPR

A-MPR (Additional MPR) has been disabled for all SAR tests by setting NS=01 on the base station simulator.

9.3.3 Required RB Size and RB Offsets for SAR Testing

According to FCC KDB 941225 D05:



- a. Per Page 4, 3) A), QPSK with 50% RB is required for the highest bandwidth.
- b. Per Page 4, footnote 2, when the maximum output power across high, mid., and low channels is < 0.5 dB, mid channel is tested. Low and high channel SAR tests are not required for QPSK, 50% RB allocation when the SAR is < 0.8 W/kg.
- c. Per Page 4, 3) B), QPSK with 1 RB for both channel edges are required for the highest bandwidth.
- d. Per Page 4, footnote 6, QPSK 1 RB allocation SAR tests were performed on the highest output power channel for the RB allocation when the average output power of the 1 RB allocation was > 0.5 dB higher than the 50% RB allocation for QPSK. Otherwise, SAR tests are performed on the channel that produced the highest SAR for QPSK with 50% RB. 1 RB low and high offset configurations are considered together for a single channel selection.
- e. Per Page 4, 3) B), I), when the SAR for QPSK 1 RB allocation tests is <1.45 W/kg, testing on the other channels is not required.
- f. Per Page 4, 4) A), 16QAM with 50% RB is required for the highest bandwidth on the channel with the highest measured SAR for QPSK with 50% RB allocation.
- g. Per Page 4, 4) A), I), when the SAR for 16 QAM, 50 % allocation tests is <1.45 W/kg, testing on the other channels is not required.
- h. Per Page 4, 4) B) and Page 5 footnote 9, 16QAM with 1RB for both channel edges are required for the highest bandwidth on the highest output power channel for the 1 RB allocation when the average output power of the 1 RB allocation is >0.5 dB higher than the 50% allocation for 16 QAM. Otherwise, SAR tests are performed on the channel that produced the highest SAR for 16 QAM with 50% RB. 1 RB low and high offset configurations are considered together for a single channel selection.
- i. Per Page 5, 4) B), I), when the SAR for 16 QAM 1 RB allocation tests is <1.45 W/kg, testing on the other channels is not required.
- j. Per Page 4, 4), A) I) and Page 5, 4), A)I, 100% RB Allocation is not required to be tested when the SAR is not > 1.45 W/kg for the highest bandwidth.
- k. Per Page 5, 5) B) I), smaller bandwidths are not required to be tested when SAR is not > 1.45 W/kg for the highest bandwidth and the maximum average output power of the smaller bandwidths across all channels and configurations is not more than 0.5 dB higher than the higher bandwidths.

9.4 SAR Testing with 802.11 Transmitters

Normal network operating configurations are not suitable for measuring the SAR of 802.11 a/b/g/n transmitters. Unpredictable fluctuations in network traffic and antenna diversity conditions can introduce undesirable variations in SAR results. The SAR for these devices should be measured using chipset based test mode software to ensure the results are consistent and reliable. See KDB Publication 248227 for more details.

9.4.1 General Device Setup

Chipset based test mode software is hardware dependent and generally varies among manufacturers. The device operating parameters established in test mode for SAR measurements must be identical to those programmed in production units, including output power levels, amplifier gain settings and other RF performance tuning parameters. The test frequencies should correspond

FCC ID: ZNFE970	 PCTEST ENGINEERING LABORATORY, INC.	SAR EVALUATION REPORT	 LG	Reviewed by: Quality Manager
Document S/N: 0Y1207050909-R1.ZNF	Test Dates: 07/05/12 - 08/23/12	DUT Type: Portable Handset		Page 21 of 62



to actual channel frequencies defined for domestic use. SAR for devices with switched diversity should be measured with only one antenna transmitting at a time during each SAR measurement, according to a fixed modulation and data rate. The same data pattern should be used for all measurements.

9.4.2 Frequency Channel Configurations [27]

For 2.4 GHz, the highest average RF output power channel between the low, mid and high channel at the lowest data rate was selected for SAR evaluation in 802.11b mode. 802.11g/n modes and higher data rates for 802.11b were additionally evaluated for SAR if the output power of the respective mode was 0.25 dB or higher than the powers of the SAR configurations tested in the 802.11b mode.

For 5 GHz, the highest average RF output power channel across the default test channels at the lowest data rate was selected for SAR evaluation in 802.11a. When the adjacent channels are higher in power than the default channels, these “required channels” were considered instead of the default channels for SAR testing. 802.11n modes and higher data rates for 802.11a/n were evaluated only if the respective mode was 0.25 dB or higher than the 802.11a mode.

If the maximum extrapolated peak SAR of the zoom scan for the highest output channel was less than 1.6 W/kg or if the 1g averaged SAR was less than 0.8 W/kg, SAR testing was not required for the other test channels in the band.

FCC ID: ZNFE970	 PCTEST ENGINEERING LABORATORY, INC.	SAR EVALUATION REPORT	 LG	Reviewed by: Quality Manager
Document S/N: 0Y1207050909-R1.ZNF	Test Dates: 07/05/12 - 08/23/12	DUT Type: Portable Handset	Page 22 of 62	

10 RF CONDUCTED POWERS

10.1.1 GSM Conducted Powers

		Maximum Burst-Averaged Output Power				
		Voice	GPRS/EDGE Data (GMSK)		EDGE Data (8-PSK)	
Band	Channel	GSM [dBm] CS (1 Slot)	GPRS [dBm] 1 Tx Slot	GPRS [dBm] 2 Tx Slot	EDGE [dBm] 1 Tx Slot	EDGE [dBm] 2 Tx Slot
Cellular	128	33.53	33.47	31.61	28.00	27.68
	190	33.67	33.61	31.64	27.92	27.60
	251	33.32	33.26	31.33	27.85	27.53
PCS	512	30.20	30.28	28.32	26.35	26.31
	661	30.34	30.36	28.42	26.38	26.37
	810	30.33	30.35	28.39	26.47	26.42

		Calculated Maximum Frame-Averaged Output Power				
		Voice	GPRS/EDGE Data (GMSK)		EDGE Data (8-PSK)	
Band	Channel	GSM [dBm] CS (1 Slot)	GPRS [dBm] 1 Tx Slot	GPRS [dBm] 2 Tx Slot	EDGE [dBm] 1 Tx Slot	EDGE [dBm] 2 Tx Slot
Cellular	128	24.50	24.44	25.59	18.97	21.66
	190	24.64	24.58	25.62	18.89	21.58
	251	24.29	24.23	25.31	18.82	21.51
PCS	512	21.17	21.25	22.30	17.32	20.29
	661	21.31	21.33	22.40	17.35	20.35
	810	21.30	21.32	22.37	17.44	20.40

Notes:

- Both burst-averaged and calculated frame-averaged powers are included. Frame-averaged power was calculated from the measured burst-averaged power by converting the slot powers into linear units and calculating the energy over 8 timeslots.
- The bolded GPRS modes were selected according to the highest frame-averaged output power table according to KDB 941225 D03.
- CS1 coding scheme was used in GPRS output power measurements and SAR Testing, as a condition where GMSK modulation was ensured. It was investigated that CS1 - CS4 settings do not have any impact on the output levels in the GPRS modes.
- MCS7 coding scheme was used to measure the output powers for EDGE since It was investigated that choosing MCS7 coding scheme will ensure 8-PSK modulation, MCS levels that produce 8PSK modulation do not have an impact on output power.

GSM Class: B
GPRS Multislot class: 10 (max 2 Tx Uplink slots)
EDGE Multislot class: 10 (max 2 Tx Uplink slots)
DTM Multislot Class: N/A



**Figure 10-1
Power Measurement Setup**

FCC ID: ZNFE970	PCTEST ENGINEERING LABORATORY, INC.	SAR EVALUATION REPORT	LG	Reviewed by: Quality Manager
Document S/N: 0Y1207050909-R1.ZNF	Test Dates: 07/05/12 - 08/23/12	DUT Type: Portable Handset	Page 23 of 62	

10.1.2 HSPA Conducted Powers

3GPP Release Version	Mode	3GPP 34.121 Subtest	Cellular Band [dBm]			PCS Band [dBm]			MPR [dB]
			4132	4183	4233	9262	9400	9538	
99	WCDMA	12.2 kbps RMC	23.45	23.34	23.35	23.39	23.42	23.50	-
99		12.2 kbps AMR	23.44	23.42	23.32	23.38	23.34	23.41	-
6	HSDPA	Subtest 1	23.35	23.35	23.25	23.35	23.38	23.30	0
6		Subtest 2	23.33	23.37	23.32	23.43	23.40	23.53	0
6		Subtest 3	22.88	22.86	22.75	22.85	22.91	23.01	0.5
6		Subtest 4	22.92	22.89	22.84	22.88	22.83	23.00	0.5
6	HSUPA	Subtest 1	23.13	23.00	22.85	22.81	22.88	22.90	0
6		Subtest 2	21.84	21.87	21.79	21.76	21.84	21.73	2
6		Subtest 3	22.31	22.20	22.18	22.10	21.93	22.03	1
6		Subtest 4	21.80	21.90	21.84	21.87	21.83	21.78	2
6		Subtest 5	23.16	23.11	22.91	23.05	23.20	22.86	0

WCDMA SAR was tested under RMC 12.2 kbps with HSPA Inactive per KDB Publication 941225 D01. HSPA SAR was not required since the average output power of the HSPA subtests was not more than 0.25 dB higher than the RMC level and SAR was less than 1.2 W/kg.

It is expected by the manufacturer that MPR for some HSUPA subtests may be as low as 0 dB according to the chipset implementation in this model. Detailed information is included in the operational description explaining how the MPR is applied for this model.

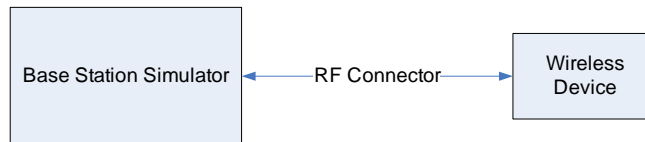



Figure 10-2
Power Measurement Setup

FCC ID: ZNFE970	 PCTEST ENGINEERING LABORATORY, INC.	SAR EVALUATION REPORT		Reviewed by: Quality Manager
Document S/N: 0Y1207050909-R1.ZNF	Test Dates: 07/05/12 - 08/23/12	DUT Type: Portable Handset		Page 24 of 62

10.2 LTE Conducted Powers



10.2.1 LTE Band 17

**Table 10-1
LTE Band 17 Conducted Powers - 10 MHz Bandwidth**

	Frequency [MHz]	Channel	Bandwidth [MHz]	Modulation	RB Size	RB Offset	Conducted Power [dBm]	Target MPR [dB]	MPR Allowed per 3GPP [dB]
Low	709	23780	10	QPSK	1	0	23.64	0	0
	709	23780	10	QPSK	1	49	23.63	0	0
	709	23780	10	QPSK	25	12	22.39	1	0-1
	709	23780	10	QPSK	50	0	22.30	1	0-1
	709	23780	10	16QAM	1	0	22.27	1	0-1
	709	23780	10	16QAM	1	49	22.31	1	0-1
	709	23780	10	16QAM	25	12	21.64	2	0-2
	709	23780	10	16QAM	50	0	21.47	2	0-2
Mid	710.0	23790	10	QPSK	1	0	23.67	0	0
	710.0	23790	10	QPSK	1	49	23.50	0	0
	710.0	23790	10	QPSK	25	12	22.40	1	0-1
	710.0	23790	10	QPSK	50	0	22.23	1	0-1
	710.0	23790	10	16QAM	1	0	22.62	1	0-1
	710.0	23790	10	16QAM	1	49	22.24	1	0-1
	710.0	23790	10	16QAM	25	12	21.41	2	0-2
	710.0	23790	10	16QAM	50	0	21.21	2	0-2
High	711	23800	10	QPSK	1	0	23.57	0	0
	711	23800	10	QPSK	1	49	23.63	0	0
	711	23800	10	QPSK	25	12	22.29	1	0-1
	711	23800	10	QPSK	50	0	22.33	1	0-1
	711	23800	10	16QAM	1	0	22.52	1	0-1
	711	23800	10	16QAM	1	49	22.44	1	0-1
	711	23800	10	16QAM	25	12	21.33	2	0-2
	711	23800	10	16QAM	50	0	21.21	2	0-2

**Table 10-2
LTE Band 17 Conducted Powers - 5 MHz Bandwidth**

	Frequency [MHz]	Channel	Bandwidth [MHz]	Modulation	RB Size	RB Offset	Conducted Power [dBm]	Target MPR [dB]	MPR Allowed per 3GPP [dB]
Low	706.5	23755	5	QPSK	1	0	23.61	0	0
	706.5	23755	5	QPSK	1	24	23.52	0	0
	706.5	23755	5	QPSK	12	6	22.52	1	0-1
	706.5	23755	5	QPSK	25	0	22.34	1	0-1
	706.5	23755	5	16-QAM	1	0	22.63	1	0-1
	706.5	23755	5	16-QAM	1	24	22.49	1	0-1
	706.5	23755	5	16-QAM	12	6	21.51	2	0-2
	706.5	23755	5	16-QAM	25	0	21.35	2	0-2
Mid	710.0	23790	5	QPSK	1	0	23.37	0	0
	710.0	23790	5	QPSK	1	24	23.44	0	0
	710.0	23790	5	QPSK	12	6	22.50	1	0-1
	710.0	23790	5	QPSK	25	0	22.24	1	0-1
	710.0	23790	5	16-QAM	1	0	22.59	1	0-1
	710.0	23790	5	16-QAM	1	24	22.47	1	0-1
	710.0	23790	5	16-QAM	12	6	21.45	2	0-2
	710.0	23790	5	16-QAM	25	0	21.14	2	0-2
High	713.5	23825	5	QPSK	1	0	23.60	0	0
	713.5	23825	5	QPSK	1	24	23.68	0	0
	713.5	23825	5	QPSK	12	6	22.63	1	0-1
	713.5	23825	5	QPSK	25	0	22.45	1	0-1
	713.5	23825	5	16-QAM	1	0	22.56	1	0-1
	713.5	23825	5	16-QAM	1	24	22.62	1	0-1
	713.5	23825	5	16-QAM	12	6	21.47	2	0-2
	713.5	23825	5	16-QAM	25	0	21.38	2	0-2

FCC ID: ZNFE970	 PCTEST ENGINEERING LABORATORY, INC.	SAR EVALUATION REPORT	 LG	Reviewed by: Quality Manager
Document S/N: 0Y1207050909-R1.ZNF	Test Dates: 07/05/12 - 08/23/12	DUT Type: Portable Handset		Page 25 of 62

10.2.2

LTE Band 5 (Cell)

Table 10-3



LTE Band 5 (Cell) Conducted Powers - 10 MHz Bandwidth

	Frequency [MHz]	Channel	Bandwidth [MHz]	Modulation	RB Size	RB Offset	Conducted Power [dBm]	Target MPR [dB]	MPR Allowed per 3GPP [dB]
Low	829	20450	10	QPSK	1	0	23.41	0	0
	829	20450	10	QPSK	1	49	23.51	0	0
	829	20450	10	QPSK	25	12	22.07	1	0-1
	829	20450	10	QPSK	50	0	21.89	1	0-1
	829	20450	10	16QAM	1	0	22.26	1	0-1
	829	20450	10	16QAM	1	49	22.21	1	0-1
	829	20450	10	16QAM	25	12	20.79	2	0-2
Mid	829	20450	10	16QAM	50	0	20.86	2	0-2
	836.5	20525	10	QPSK	1	0	23.40	0	0
	836.5	20525	10	QPSK	1	49	23.57	0	0
	836.5	20525	10	QPSK	25	12	22.26	1	0-1
	836.5	20525	10	QPSK	50	0	22.18	1	0-1
	836.5	20525	10	16QAM	1	0	22.56	1	0-1
	836.5	20525	10	16QAM	1	49	22.27	1	0-1
High	836.5	20525	10	16QAM	25	12	21.23	2	0-2
	836.5	20525	10	16QAM	50	0	21.02	2	0-2
	844	20600	10	QPSK	1	0	23.64	0	0
	844	20600	10	QPSK	1	49	23.52	0	0
	844	20600	10	QPSK	25	12	22.30	1	0-1
	844	20600	10	QPSK	50	0	22.08	1	0-1
	844	20600	10	16QAM	1	0	22.44	1	0-1
844	20600	10	16QAM	1	49	22.63	1	0-1	
844	20600	10	16QAM	25	12	21.34	2	0-2	
844	20600	10	16QAM	50	0	21.14	2	0-2	

Table 10-4

LTE Band 5 (Cell) Conducted Powers - 5 MHz Bandwidth

	Frequency [MHz]	Channel	Bandwidth [MHz]	Modulation	RB Size	RB Offset	Conducted Power [dBm]	Target MPR [dB]	MPR Allowed per 3GPP [dB]
Low	826.5	20425	5	QPSK	1	0	23.35	0	0
	826.5	20425	5	QPSK	1	24	23.36	0	0
	826.5	20425	5	QPSK	12	6	22.29	1	0-1
	826.5	20425	5	QPSK	25	0	22.26	1	0-1
	826.5	20425	5	16-QAM	1	0	22.13	1	0-1
	826.5	20425	5	16-QAM	1	24	22.27	1	0-1
	826.5	20425	5	16-QAM	12	6	21.37	2	0-2
Mid	826.5	20425	5	16-QAM	25	0	21.25	2	0-2
	836.5	20525	5	QPSK	1	0	23.37	0	0
	836.5	20525	5	QPSK	1	24	23.39	0	0
	836.5	20525	5	QPSK	12	6	22.45	1	0-1
	836.5	20525	5	QPSK	25	0	22.32	1	0-1
	836.5	20525	5	16-QAM	1	0	22.36	1	0-1
	836.5	20525	5	16-QAM	1	24	22.04	1	0-1
High	836.5	20525	5	16-QAM	12	6	21.49	2	0-2
	836.5	20525	5	16-QAM	25	0	21.19	2	0-2
	846.5	20625	5	QPSK	1	0	23.35	0	0
	846.5	20625	5	QPSK	1	24	23.50	0	0
	846.5	20625	5	QPSK	12	6	22.18	1	0-1
	846.5	20625	5	QPSK	25	0	22.08	1	0-1
	846.5	20625	5	16-QAM	1	0	22.30	1	0-1
846.5	20625	5	16-QAM	1	24	22.54	1	0-1	
846.5	20625	5	16-QAM	12	6	21.32	2	0-2	
846.5	20625	5	16-QAM	25	0	21.07	2	0-2	

FCC ID: ZNFE970		SAR EVALUATION REPORT		Reviewed by: Quality Manager
Document S/N: 0Y1207050909-R1.ZNF	Test Dates: 07/05/12 - 08/23/12	DUT Type: Portable Handset		Page 26 of 62



10.2.3 LTE Band 4 (AWS)

Table 10-5
LTE Band 4 (AWS) Conducted Powers - 10 MHz Bandwidth

	Frequency [MHz]	Channel	Bandwidth [MHz]	Modulation	RB Size	RB Offset	Conducted Power [dBm]	Target MPR [dB]	MPR Allowed per 3GPP [dB]
Low	1715	20000	10	QPSK	1	0	23.64	0	0
	1715	20000	10	QPSK	1	49	23.45	0	0
	1715	20000	10	QPSK	25	12	22.04	1	0-1
	1715	20000	10	QPSK	50	0	21.85	1	0-1
	1715	20000	10	16QAM	1	0	22.42	1	0-1
	1715	20000	10	16QAM	1	49	21.99	1	0-1
	1715	20000	10	16QAM	25	12	20.92	2	0-2
Mid	1715	20000	10	16QAM	50	0	20.83	2	0-2
	1732.5	20175	10	QPSK	1	0	23.41	0	0
	1732.5	20175	10	QPSK	1	49	23.31	0	0
	1732.5	20175	10	QPSK	25	12	22.03	1	0-1
	1732.5	20175	10	QPSK	50	0	21.96	1	0-1
	1732.5	20175	10	16QAM	1	0	21.80	1	0-1
	1732.5	20175	10	16QAM	1	49	22.23	1	0-1
High	1732.5	20175	10	16QAM	25	12	21.03	2	0-2
	1732.5	20175	10	16QAM	50	0	20.88	2	0-2
	1750	20350	10	QPSK	1	0	23.54	0	0
	1750	20350	10	QPSK	1	49	23.33	0	0
	1750	20350	10	QPSK	25	12	22.16	1	0-1
	1750	20350	10	QPSK	50	0	22.00	1	0-1
	1750	20350	10	16QAM	1	0	22.38	1	0-1
1750	20350	10	16QAM	1	49	22.26	1	0-1	
1750	20350	10	16QAM	25	12	21.20	2	0-2	
1750	20350	10	16QAM	50	0	20.80	2	0-2	

Table 10-6
LTE Band 4 (AWS) Conducted Powers - 5 MHz Bandwidth

	Frequency [MHz]	Channel	Bandwidth [MHz]	Modulation	RB Size	RB Offset	Conducted Power [dBm]	Target MPR [dB]	MPR Allowed per 3GPP [dB]
Low	1712.5	19975	5	QPSK	1	0	23.59	0	0
	1712.5	19975	5	QPSK	1	24	23.41	0	0
	1712.5	19975	5	QPSK	12	6	22.03	1	0-1
	1712.5	19975	5	QPSK	25	0	22.09	1	0-1
	1712.5	19975	5	16-QAM	1	0	22.38	1	0-1
	1712.5	19975	5	16-QAM	1	24	22.01	1	0-1
	1712.5	19975	5	16-QAM	12	6	21.13	2	0-2
Mid	1712.5	19975	5	16-QAM	25	0	21.05	2	0-2
	1732.5	20175	5	QPSK	1	0	23.28	0	0
	1732.5	20175	5	QPSK	1	24	23.45	0	0
	1732.5	20175	5	QPSK	12	6	22.23	1	0-1
	1732.5	20175	5	QPSK	25	0	22.05	1	0-1
	1732.5	20175	5	16-QAM	1	0	22.04	1	0-1
	1732.5	20175	5	16-QAM	1	24	22.37	1	0-1
High	1732.5	20175	5	16-QAM	12	6	21.21	2	0-2
	1732.5	20175	5	16-QAM	25	0	20.93	2	0-2
	1752.5	20375	5	QPSK	1	0	23.32	0	0
	1752.5	20375	5	QPSK	1	24	23.30	0	0
	1752.5	20375	5	QPSK	12	6	22.15	1	0-1
	1752.5	20375	5	QPSK	25	0	21.95	1	0-1
	1752.5	20375	5	16-QAM	1	0	22.20	1	0-1
1752.5	20375	5	16-QAM	1	24	22.37	1	0-1	
1752.5	20375	5	16-QAM	12	6	21.29	2	0-2	
1752.5	20375	5	16-QAM	25	0	20.88	2	0-2	

FCC ID: ZNFE970		SAR EVALUATION REPORT		Reviewed by: Quality Manager
Document S/N: 0Y1207050909-R1.ZNF	Test Dates: 07/05/12 - 08/23/12	DUT Type: Portable Handset		Page 27 of 62

10.2.4 LTE Band 2 (PCS)

Table 10-7



LTE Band 2 (PCS) Conducted Powers - 10 MHz Bandwidth

	Frequency [MHz]	Channel	Bandwidth [MHz]	Modulation	RB Size	RB Offset	Conducted Power [dBm]	Target MPR [dB]	MPR Allowed per 3GPP [dB]
Low	1855	18650	10	QPSK	1	0	23.51	0	0
	1855	18650	10	QPSK	1	49	23.47	0	0
	1855	18650	10	QPSK	25	12	22.00	1	0-1
	1855	18650	10	QPSK	50	0	21.88	1	0-1
	1855	18650	10	16QAM	1	0	21.98	1	0-1
	1855	18650	10	16QAM	1	49	21.94	1	0-1
	1855	18650	10	16QAM	25	12	20.98	2	0-2
Mid	1880.0	18900	10	16QAM	50	0	20.90	2	0-2
	1880.0	18900	10	QPSK	1	0	23.30	0	0
	1880.0	18900	10	QPSK	1	49	23.33	0	0
	1880.0	18900	10	QPSK	25	12	21.71	1	0-1
	1880.0	18900	10	QPSK	50	0	21.90	1	0-1
	1880.0	18900	10	16QAM	1	0	22.08	1	0-1
	1880.0	18900	10	16QAM	1	49	22.18	1	0-1
High	1880.0	18900	10	16QAM	25	12	20.75	2	0-2
	1880.0	18900	10	16QAM	50	0	20.80	2	0-2
	1905	19150	10	QPSK	1	0	23.38	0	0
	1905	19150	10	QPSK	1	49	23.40	0	0
	1905	19150	10	QPSK	25	12	22.05	1	0-1
	1905	19150	10	QPSK	50	0	21.88	1	0-1
	1905	19150	10	16QAM	1	0	22.19	1	0-1
	1905	19150	10	16QAM	1	49	22.29	1	0-1
	1905	19150	10	16QAM	25	12	21.04	2	0-2
	1905	19150	10	16QAM	50	0	20.91	2	0-2
	1905	19150	10	16QAM	50	0	20.91	2	0-2

Table 10-8

LTE Band 2 (PCS) Conducted Powers - 5 MHz Bandwidth

	Frequency [MHz]	Channel	Bandwidth [MHz]	Modulation	RB Size	RB Offset	Conducted Power [dBm]	Target MPR [dB]	MPR Allowed per 3GPP [dB]
Low	1852.5	18625	5	QPSK	1	0	23.51	0	0
	1852.5	18625	5	QPSK	1	24	23.45	0	0
	1852.5	18625	5	QPSK	12	6	22.05	1	0-1
	1852.5	18625	5	QPSK	25	0	22.07	1	0-1
	1852.5	18625	5	16-QAM	1	0	22.22	1	0-1
	1852.5	18625	5	16-QAM	1	24	22.13	1	0-1
	1852.5	18625	5	16-QAM	12	6	21.17	2	0-2
	1852.5	18625	5	16-QAM	25	0	21.01	2	0-2
Mid	1880.0	18900	5	16-QAM	25	0	21.11	2	0-2
	1880.0	18900	5	QPSK	1	0	23.35	0	0
	1880.0	18900	5	QPSK	1	24	23.28	0	0
	1880.0	18900	5	QPSK	12	6	22.19	1	0-1
	1880.0	18900	5	QPSK	25	0	22.08	1	0-1
	1880.0	18900	5	16-QAM	1	0	22.32	1	0-1
	1880.0	18900	5	16-QAM	1	24	22.07	1	0-1
	1880.0	18900	5	16-QAM	12	6	21.21	2	0-2
High	1907.5	19175	5	16-QAM	25	0	21.16	2	0-2
	1907.5	19175	5	QPSK	1	0	23.38	0	0
	1907.5	19175	5	QPSK	1	24	23.21	0	0
	1907.5	19175	5	QPSK	12	6	22.08	1	0-1
	1907.5	19175	5	QPSK	25	0	22.02	1	0-1
	1907.5	19175	5	16-QAM	1	0	22.16	1	0-1
	1907.5	19175	5	16-QAM	1	24	22.38	1	0-1
	1907.5	19175	5	16-QAM	12	6	21.21	2	0-2
1907.5	19175	5	16-QAM	25	0	21.16	2	0-2	

FCC ID: ZNFE970	 PCTEST ENGINEERING LABORATORY, INC.	SAR EVALUATION REPORT	 LG	Reviewed by: Quality Manager
Document S/N: OY1207050909-R1.ZNF	Test Dates: 07/05/12 - 08/23/12	DUT Type: Portable Handset		Page 28 of 62



10.2.5 Required RB Size and RB Offsets for SAR Testing

According to FCC KDB 941225 D05:

- 1) Per Page 4, 3) A), QPSK with 50% RB is required for the highest bandwidth.
- 2) Per Page 4, footnote 2, when the maximum output power across high, mid., and low channels is < 0.5 dB, mid channel is tested. Low and high channel SAR tests are not required for QPSK, 50% RB allocation when the SAR is < 0.8 W/kg.
- 3) Per Page 4, 3) B), QPSK with 1 RB for both channel edges are required for the highest bandwidth.
- 4) Per Page 4, footnote 6, QPSK 1 RB allocation SAR tests were performed on the highest output power channel for the RB allocation when the average output power of the 1 RB allocations were > 0.5 dB higher than the 50% RB allocation for QPSK. Otherwise, SAR tests are performed on the channel that produced the highest SAR for QPSK with 50% RB. 1 RB low and high offset configurations are considered together for a single channel selection.
- 5) Per Page 4, 3) B), I), when the SAR for QPSK 1 RB allocation tests is <1.45 W/kg, testing on the other channels is not required.
- 6) Per Page 4, 4) A), 16QAM with 50% RB is required for the highest bandwidth on the channel with the highest measured SAR for QPSK with 50% RB allocation.
- 7) Per Page 4, 4) A), I), when the SAR for 16 QAM, 50 % allocation tests is <1.45 W/kg, testing on the other channels is not required.
- 8) Per Page 4, 4) B) and Page 5 footnote 9, 16QAM with 1RB for both channel edges are required for the highest bandwidth on the highest output power channel for the 1 RB allocation when the average output power of the 1 RB allocation is >0.5 dB higher than the 50% allocation for 16 QAM. Otherwise, SAR tests are performed on the channel that produced the highest SAR for 16 QAM with 50% RB. 1 RB low and high offset configurations are considered together for a single channel selection.
- 9) Per Page 5, 4) B), I), when the SAR for 16 QAM 1 RB allocation tests is <1.45 W/kg, testing on the other channels is not required.
- 10) Per Page 4, 4), A) I) and Page 5, 4), A),I), 100% RB Allocation is not required to be tested when the SAR is not > 1.45 W/kg for the highest bandwidth.
- 11) Per Page 5, 5) B) I), smaller bandwidths are not required to be tested when SAR is not > 1.45 W/kg for the highest bandwidth and the maximum average output power of the smaller bandwidths across all channels and configurations is not more than 0.5 dB higher than the higher bandwidths



Figure 10-3
Power Measurement Setup

FCC ID: ZNFE970	 PCTEST ENGINEERING LABORATORY, INC.	SAR EVALUATION REPORT	 LG	Reviewed by: Quality Manager
Document S/N: 0Y1207050909-R1.ZNF	Test Dates: 07/05/12 - 08/23/12	DUT Type: Portable Handset		Page 29 of 62

10.3 WLAN Conducted Powers

**Table 10-9
IEEE 802.11b Average RF Power**

Mode	Freq [MHz]	Channel	Conducted Power [dBm]			
			Data Rate [Mbps]			
			1	2	5.5	11
802.11b	2412	1	16.27	15.91	16.51	16.27
802.11b	2437	6	15.73	15.75	15.93	16.30
802.11b	2462	11	15.90	15.96	15.79	16.30

**Table 10-10
IEEE 802.11g Average RF Power**

Mode	Freq [MHz]	Channel	Conducted Power [dBm]							
			Data Rate [Mbps]							
			6	9	12	18	24	36	48	54
802.11g	2412	1	12.56	12.56	12.39	12.36	12.51	12.51	12.51	12.51
802.11g	2437	6	12.47	12.61	12.58	12.41	12.46	12.43	12.43	12.38
802.11g	2462	11	12.53	12.58	12.67	12.39	12.43	12.68	12.39	12.59

**Table 10-11
IEEE 802.11n Average RF Power**

Mode	Freq [MHz]	Channel	Conducted Power [dBm]							
			Data Rate [Mbps]							
			6.5	13	20	26	39	52	58	65
802.11n	2412	1	11.55	11.53	11.40	11.60	11.39	11.51	11.42	11.56
802.11n	2437	6	11.53	11.39	11.48	11.37	11.64	11.47	11.42	11.46
802.11n	2462	11	11.35	11.55	11.72	11.49	11.46	11.68	11.38	11.36

**Table 10-12
IEEE 802.11a Average RF Power**

Mode	Freq [MHz]	Channel	Conducted Power [dBm]							
			Data Rate [Mbps]							
			6	9	12	18	24	36	48	54
802.11a	5180	36*	14.43	14.41	14.41	14.60	14.61	14.65	14.64	14.68
802.11a	5200	40	14.57	14.52	14.47	14.61	14.42	14.53	14.48	14.55
802.11a	5220	44	14.48	14.31	14.37	14.39	14.41	14.35	14.40	14.35
802.11a	5240	48*	14.46	14.37	14.57	14.55	14.45	14.49	14.50	14.51
802.11a	5260	52*	14.53	14.41	14.40	14.43	14.40	14.48	14.51	14.48
802.11a	5280	56	14.39	14.42	14.35	14.36	14.38	14.38	14.40	14.41
802.11a	5300	60	14.29	14.34	14.38	14.30	14.33	14.31	14.32	14.35
802.11a	5320	64*	14.40	14.38	14.45	14.27	14.38	14.29	14.43	14.42
802.11a	5500	100	14.21	14.25	14.28	14.40	14.17	14.17	14.35	14.25
802.11a	5520	104*	14.28	14.47	14.34	14.15	14.42	14.14	14.15	14.13
802.11a	5540	108	14.47	14.31	14.52	14.33	14.17	14.18	14.20	14.15
802.11a	5560	112	14.33	14.29	14.30	14.45	14.29	14.43	14.32	14.39
802.11a	5580	116*	14.09	13.99	13.91	14.16	14.02	14.05	14.09	14.13
802.11a	5600	120	N/A	N/A	N/A	N/A	N/A	N/A	N/A	N/A
802.11a	5620	124	N/A	N/A	N/A	N/A	N/A	N/A	N/A	N/A
802.11a	5640	128	N/A	N/A	N/A	N/A	N/A	N/A	N/A	N/A
802.11a	5660	132	14.23	14.32	14.18	14.11	13.99	13.98	13.96	13.94
802.11a	5680	136*	14.20	14.26	14.04	14.21	14.01	13.98	13.89	13.91
802.11a	5700	140	14.03	14.23	14.28	14.06	14.18	14.19	14.28	14.22
802.11a	5745	149*	14.03	14.01	14.09	14.08	14.06	13.71	14.04	14.02
802.11a	5765	153	13.96	14.21	13.87	13.96	14.01	14.01	13.93	13.96
802.11a	5785	157*	14.26	14.22	14.12	14.30	14.13	14.34	14.20	13.91
802.11a	5805	161*	14.20	14.20	14.22	14.24	14.21	14.23	14.36	14.25
802.11a	5825	165	13.74	13.95	13.80	13.86	13.97	13.97	13.99	13.99

Per FCC KDB Publication 443999 and RSS-210 A9.2(3), transmission on channels which overlap the 5600-5650 MHz is prohibited as a client. This device does not transmit any beacons or initiate any transmissions in 5.3 and 5.5 GHz Band. (*) – indicates default channels per KDB Publication 248227. When the adjacent channels are higher in power than the default channels, these “required channels” are considered instead of the default channels for SAR testing.



FCC ID: ZNFE970	 PCTEST ENGINEERING LABORATORY, INC.	SAR EVALUATION REPORT	 LG	Reviewed by: Quality Manager
Document S/N: 0Y1207050909-R1.ZNF	Test Dates: 07/05/12 - 08/23/12	DUT Type: Portable Handset		Page 30 of 62

Table 10-13
IEEE 802.11n (20 MHz Bandwidth) Average RF Power



Mode	Freq [MHz]	Channel	Conducted Power [dBm]							
			Data Rate [Mbps]							
			6.5	13	20	26	39	52	58	65
802.11n	5180	36*	13.48	13.39	13.62	13.68	13.72	13.56	13.60	13.65
802.11n	5200	40	13.28	13.29	13.36	13.54	13.49	13.49	13.53	13.28
802.11n	5220	44	13.14	13.26	13.35	13.34	13.47	13.35	13.40	13.26
802.11n	5240	48*	13.44	13.39	13.34	13.38	13.38	13.54	13.34	13.32
802.11n	5260	52*	13.32	13.33	13.50	13.27	13.35	13.29	13.18	13.25
802.11n	5280	56	13.62	13.74	13.73	13.76	13.53	13.68	13.67	13.73
802.11n	5300	60	13.57	13.72	13.62	13.63	13.70	13.73	13.74	13.80
802.11n	5320	64*	13.60	13.74	13.77	13.77	13.75	13.62	13.41	13.66
802.11n	5500	100	13.33	13.62	13.41	13.32	13.17	13.21	13.17	13.30
802.11n	5520	104*	13.48	13.20	13.19	13.20	13.11	13.19	13.22	13.20
802.11n	5540	108	13.46	13.47	13.34	13.56	13.00	13.13	13.24	13.45
802.11n	5560	112	13.40	13.32	13.35	13.34	13.53	13.35	13.40	13.45
802.11n	5580	116*	12.99	13.05	13.06	13.01	13.09	13.03	13.02	13.17
802.11n	5600	120	N/A	N/A	N/A	N/A	N/A	N/A	N/A	N/A
802.11n	5620	124	N/A	N/A	N/A	N/A	N/A	N/A	N/A	N/A
802.11n	5640	128	N/A	N/A	N/A	N/A	N/A	N/A	N/A	N/A
802.11n	5660	132	13.11	13.28	13.25	13.35	12.79	12.93	12.89	12.89
802.11n	5680	136*	13.33	13.22	13.21	13.21	13.31	13.06	13.13	13.22
802.11n	5700	140	12.99	13.12	13.13	13.09	12.97	13.18	13.12	13.14
802.11n	5745	149*	12.99	13.02	13.00	12.83	12.88	12.80	12.73	12.84
802.11n	5765	153	12.89	13.10	12.92	13.14	12.78	12.92	12.95	12.71
802.11n	5785	157*	13.19	13.05	12.85	12.72	12.87	13.38	12.82	12.96
802.11n	5805	161*	13.19	13.31	13.20	13.05	13.19	13.21	13.28	12.98
802.11n	5825	165	12.97	13.05	13.08	13.07	13.08	13.09	12.95	13.12

Per FCC KDB Publication 443999 and RSS-210 A9.2(3), transmission on channels which overlap the 5600-5650 MHz is prohibited as a client. This device does not transmit any beacons or initiate any transmissions in 5.3 and 5.5 GHz Bands. (*) – indicates default channels per KDB Publication 248227. When the adjacent channels are higher in power than the default channels, these “required channels” are considered instead of the default channels for SAR testing.

Table 10-14
IEEE 802.11n (40 MHz Bandwidth) Average RF Power

Mode	Freq [MHz]	Channel	802.11n (40MHz Bandwidth) Conducted Power [dBm]							
			Data Rate [Mbps]							
			13.5/15	27/30	40.5/45	54/60	81/90	108/120	121.5/135	135/150
802.11n	5190	38*	12.00	12.00	12.08	12.12	12.13	12.10	12.08	12.14
802.11n	5230	46	12.44	12.38	12.38	12.41	12.42	12.30	12.37	12.38
802.11n	5270	54	12.51	12.71	12.56	12.56	12.54	12.57	12.59	12.60
802.11n	5310	62*	12.31	12.37	12.60	12.46	12.46	12.48	12.50	12.54
802.11n	5510	102*	12.40	12.35	12.33	12.35	12.37	12.35	12.32	12.20
802.11n	5550	110	11.93	12.05	12.31	12.10	12.01	12.26	11.97	12.09
802.11n	5590	118	N/A	N/A	N/A	N/A	N/A	N/A	N/A	N/A
802.11n	5630	126	N/A	N/A	N/A	N/A	N/A	N/A	N/A	N/A
802.11n	5670	134	12.01	12.00	11.79	12.02	11.93	12.11	12.01	11.99
802.11n	5755	151*	12.16	12.16	12.06	12.15	12.13	12.09	12.09	12.15
802.11n	5795	159	11.68	11.83	11.75	11.76	11.75	11.75	11.61	11.87

Per FCC KDB Publication 443999 and RSS-210 A9.2(3), transmission on channels which overlap the 5600-5650 MHz is prohibited as a client. This device does not transmit any beacons or initiate any transmissions in 5.3 and 5.5 GHz Bands. (*) – indicates default channels per KDB Publication 248227. When the adjacent channels are higher in power than the default channels, these “required channels” are considered instead of the default channels for SAR testing.



FCC ID: ZNFE970	 PCTEST ENGINEERING LABORATORY, INC.	SAR EVALUATION REPORT	 LG	Reviewed by: Quality Manager
Document S/N: 0Y1207050909-R1.ZNF	Test Dates: 07/05/12 - 08/23/12	DUT Type: Portable Handset		Page 31 of 62

Justification for reduced test configurations for WIFI channels per KDB Publication 248227 and April 2010 FCC/TCB Meeting Notes:

- For 2.4 GHz, highest average RF output power channel for the lowest data rate for IEEE 802.11b were selected for SAR evaluation. Other IEEE 802.11 modes (including 802.11g/n) were not investigated since the average output powers over all channels and data rates were not more than 0.25 dB higher than the tested channel in the lowest data rate of IEEE 802.11b mode.
- For 5 GHz, highest average RF output power channel for the lowest data rate for IEEE 802.11a were selected for SAR evaluation. Other IEEE 802.11 modes (including 802.11n 20 MHz Bandwidth and IEEE 802.11n 40 MHz Bandwidth) were not investigated since the average output powers over all channels and data rates were not more than 0.25 dB higher than the tested channel in the lowest data rate of IEEE 802.11a mode.
- When the maximum extrapolated peak SAR of the zoom scan for the maximum output channel is <1.6 W/kg and the 1g averaged SAR is <0.8 W/kg, SAR testing on other channels is not required. Otherwise, the other default (or corresponding required) test channels were additionally tested using the lowest data rate.
- The data rate and channel configurations indicated by the bolded power above were tested for SAR.



Figure 10-4
Power Measurement Setup



FCC ID: ZNFE970	 PCTEST ENGINEERING LABORATORY, INC.	SAR EVALUATION REPORT	 LG	Reviewed by: Quality Manager
Document S/N: 0Y1207050909-R1.ZNF	Test Dates: 07/05/12 - 08/23/12	DUT Type: Portable Handset		Page 32 of 62

11 SYSTEM VERIFICATION

11.1 Tissue Verification

**Table 11-1
Measured Tissue Properties**

Calibrated for Tests Performed on:	Tissue Type	Tissue Temp During Calibration (C°)	Measured Frequency (MHz)	Measured Conductivity, σ (S/m)	Measured Dielectric Constant, ϵ	TARGET Conductivity, σ (S/m)	TARGET Dielectric Constant, ϵ	% dev σ	% dev ϵ
07/10/2012	750H	23.0	680	0.858	44.05	0.89	42.27	-3.05%	4.20%
			695	0.869	44.12	0.89	42.19	-1.92%	4.57%
			710	0.874	43.37	0.89	42.11	-1.47%	2.98%
			725	0.899	43.33	0.89	42.03	1.24%	3.09%
			740	0.909	43.56	0.89	41.95	2.25%	3.83%
07/05/2012	835H	24.9	755	0.929	42.73	0.89	41.88	4.26%	2.04%
			820	0.893	40.65	0.90	41.57	-0.56%	-2.22%
			835	0.906	40.46	0.90	41.50	0.67%	-2.51%
08/22/2012	835H	24.3	850	0.922	40.28	0.92	41.50	0.66%	-2.94%
			820	0.878	39.83	0.898	41.571	-2.23%	-4.19%
			835	0.892	39.60	0.900	41.500	-0.89%	-4.58%
07/06/2012	1750H	24.9	850	0.907	39.47	0.916	41.500	-0.98%	-4.89%
			1710	1.354	39.06	1.35	40.14	0.45%	-2.68%
			1750	1.391	38.88	1.37	40.10	1.53%	-3.04%
07/11/2012	1900H	23.3	1790	1.430	38.71	1.39	40.02	2.58%	-3.27%
			1850	1.394	38.39	1.40	40.00	-0.43%	-4.03%
			1880	1.426	38.26	1.40	40.00	1.86%	-4.35%
08/23/2012	1900H	22.5	1910	1.458	38.13	1.40	40.00	4.14%	-4.67%
			1850	1.373	41.19	1.400	40.000	-1.93%	2.97%
			1880	1.419	41.00	1.400	40.000	1.36%	2.50%
07/10/2012	2450H	23.3	1910	1.455	40.90	1.400	40.000	3.93%	2.25%
			2401	1.824	39.10	1.76	39.30	3.75%	-0.50%
			2450	1.875	38.92	1.80	39.20	4.17%	-0.71%
07/09/2012	5200H-5800H	22.9	2499	1.933	38.71	1.85	39.14	4.37%	-1.09%
			5200	4.458	36.01	4.660	36.000	-4.33%	0.03%
			5240	4.507	35.94	4.700	35.960	-4.11%	-0.06%
			5260	4.545	35.96	4.720	35.940	-3.71%	0.06%
			5500	4.743	35.58	4.965	35.650	-4.47%	-0.20%
			5540	4.796	35.65	5.007	35.590	-4.21%	0.17%
			5785	5.029	35.33	5.255	35.315	-4.30%	0.04%
07/11/2012	750B	22.9	5800	5.052	35.34	5.270	35.300	-4.14%	0.11%
			680	0.924	55.13	0.96	56.07	-3.35%	-1.67%
			695	0.938	54.94	0.96	55.99	-1.99%	-1.87%
			710	0.953	54.80	0.96	55.90	-0.52%	-1.97%
			725	0.968	54.65	0.96	55.82	0.83%	-2.09%
			740	0.982	54.52	0.96	55.73	2.19%	-2.18%
07/09/2012	835B	24.8	755	0.996	54.38	0.96	55.65	3.43%	-2.28%
			820	0.971	52.85	0.97	55.28	0.21%	-4.40%
			835	0.975	52.59	0.97	55.20	0.52%	-4.73%
07/06/2012	1750B	24.9	850	0.991	52.72	0.99	55.15	0.30%	-4.41%
			1710	1.410	51.91	1.46	53.54	-3.42%	-3.04%
			1750	1.446	51.78	1.49	53.43	-2.95%	-3.09%
07/09/2012	1900B	24.9	1790	1.487	51.66	1.51	53.33	-1.52%	-3.13%
			1850	1.462	51.95	1.52	53.30	-3.82%	-2.53%
			1880	1.489	51.86	1.52	53.30	-2.04%	-2.70%
07/09/2012	2450B	23.6	1910	1.520	51.77	1.52	53.30	0.00%	-2.87%
			2401	1.834	52.83	1.90	52.77	-3.63%	0.12%
			2450	1.889	52.69	1.95	52.70	-3.13%	-0.02%
07/05/2012	5200B-5800B	23.1	2499	1.949	52.56	2.02	52.64	-3.47%	-0.15%
			5200	5.071	49.94	5.299	49.014	-4.30%	1.89%
			5240	5.135	49.93	5.346	48.933	-3.95%	2.04%
			5260	5.156	49.99	5.369	48.906	-3.97%	2.22%
			5500	5.498	49.29	5.650	48.580	-2.69%	1.46%
			5785	5.892	48.86	5.982	48.242	-1.50%	1.28%
			5800	5.909	48.85	6.000	48.200	-1.52%	1.35%

FCC ID: ZNFE970		SAR EVALUATION REPORT		Reviewed by: Quality Manager
Document S/N: 0Y1207050909-R1.ZNF	Test Dates: 07/05/12 - 08/23/12	DUT Type: Portable Handset		Page 33 of 62

Note: KDB Publication 450824 was ensured to be applied for probe calibration frequencies greater than or equal to 50 MHz of the DUT frequencies.

The above measured tissue parameters were used in the DASY software to perform interpolation via the DASY software to determine actual dielectric parameters at the test frequencies (per IEEE 1528 6.6.1.2).



Probe calibration used within ±100 MHz of the test frequency in either 5.725 - 5.85 or 5.47-5.725 GHz is acceptable per KDB Publication 865664 since the design of the SAR probe supports the extended frequency, provided the DASY software version recommended is used for the tests, and the expanded calibration uncertainty (k=2) is less than or equal to 15% (See SAR probe calibration certificate for this information). The dielectric and conductivities measured are within 10% and 5% respectively of the target parameters specified in Supplement C 01-01.

11.2 Measurement Procedure for Tissue verification

- 1) The network analyzer and probe system was configured and calibrated.
- 2) The probe was immersed in the sample which was placed in a nonmetallic container. Trapped air bubbles beneath the flange were minimized by placing the probe at a slight angle.
- 3) The complex admittance with respect to the probe aperture was measured
- 4) The complex relative permittivity, for example from the below equation (Pournaropoulos and Misra):

$$Y = \frac{j2\omega\epsilon_r\epsilon_0}{[\ln(b/a)]^2} \int_a^b \int_a^b \int_0^\pi \cos\phi' \frac{\exp[-j\omega r(\mu_0\epsilon_r\epsilon_0)^{1/2}]}{r} d\phi' d\rho' d\rho$$

where Y is the admittance of the probe in contact with the sample, the primed and unprimed coordinates refer to source and observation points, respectively, $r^2 = \rho^2 + \rho'^2 - 2\rho\rho' \cos\phi'$, ω is the angular frequency, and $j = \sqrt{-1}$.

FCC ID: ZNFE970	 PCTEST ENGINEERING LABORATORY, INC.	SAR EVALUATION REPORT	 LG	Reviewed by: Quality Manager
Document S/N: 0Y1207050909-R1.ZNF	Test Dates: 07/05/12 - 08/23/12	DUT Type: Portable Handset		Page 34 of 62

11.3 Test System Verification

Prior to assessment, the system is verified to $\pm 10\%$ of the manufacturer SAR measurement on the reference dipole at the time of calibration.

**Table 11-2
System Verification Results**

System Verification TARGET & MEASURED											
Tissue Frequency (MHz)	Tissue Type	Date:	Amb. Temp (°C)	Liquid Temp (°C)	Input Power (W)	Dipole SN	Probe SN	Measured SAR _{1g} (W/kg)	1 W Target SAR _{1g} (W/kg)	1 W Normalized SAR _{1g} (W/kg)	Deviation (%)
750	Head	07/10/2012	23.2	22.5	0.100	1054	3287	0.833	8.520	8.330	-2.23%
835	Head	07/05/2012	24.3	23.4	0.100	4d133	3258	1.01	9.450	10.100	6.88%
835	Head	08/22/2012	24.9	24.6	0.100	4d119	3258	0.962	9.420	9.620	2.12%
1750	Head	07/06/2012	23.9	23.1	0.100	1008	3022	3.77	36.400	37.700	3.57%
1900	Head	07/11/2012	24.6	23.8	0.100	5d141	3209	4.13	39.800	41.300	3.77%
1900	Head	08/23/2012	23.9	22.7	0.100	5d149	3287	4.18	39.300	41.800	6.36%
2450	Head	07/10/2012	24.2	24.1	0.040	797	3209	2.23	52.100	55.750	7.01%
5200	Head	07/09/2012	24.4	23.3	0.018	1057	3589	1.49	79.100	82.778	4.65%
5500	Head	07/09/2012	24.6	23.5	0.018	1057	3589	1.5	84.900	83.333	-1.85%
5800	Head	07/09/2012	24.8	23.7	0.018	1057	3589	1.48	79.500	82.222	3.42%
750	Body	07/11/2012	24.0	22.8	0.100	1003	3022	0.89	8.720	8.900	2.06%
835	Body	07/09/2012	24.9	23.3	0.100	4d119	3258	1	9.560	10.000	4.60%
1750	Body	07/06/2012	23.8	22.9	0.100	1008	3022	3.94	37.400	39.400	5.35%
1900	Body	07/09/2012	23.7	24.8	0.100	5d080	3022	4.23	40.900	42.300	3.42%
2450	Body	07/09/2012	24.6	24.0	0.100	797	3209	5.19	50.800	51.900	2.17%
5200	Body	07/05/2012	24.7	23.6	0.017	1057	3589	1.26	73.400	74.118	0.98%
5500	Body	07/05/2012	24.7	23.6	0.017	1057	3589	1.34	78.900	78.824	-0.10%
5800	Body	07/05/2012	24.9	23.8	0.017	1057	3589	1.31	74.300	77.059	3.71%

Note: Per KDB Publication 865664, when a reference dipole is not defined within $\pm 100\text{MHz}$ of the test frequency, the system verification may be conducted within $\pm 200\text{ MHz}$ of the center frequency of the measurement frequencies if the SAR probe calibration is valid and the same tissue-equivalent matter is used for verification and test measurements.

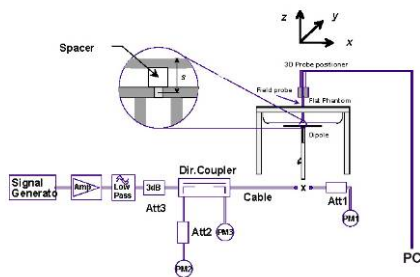

**Figure 11-1
System Verification Setup Diagram**



**Figure 11-2
System Verification Setup Photo**

FCC ID: ZNFE970	PCTEST ENGINEERING LABORATORY, INC.	SAR EVALUATION REPORT	LG	Reviewed by: Quality Manager
Document S/N: 0Y1207050909-R1.ZNF	Test Dates: 07/05/12 - 08/23/12	DUT Type: Portable Handset		Page 35 of 62

12 SAR DATA SUMMARY



12.1 Standalone Head SAR Data

**Table 12-1
GSM 850 Head SAR Results**

MEASUREMENT RESULTS										
FREQUENCY		Mode/Band	Service	Conducted Power [dBm]	Power Drift [dB]	Side	Test Position	Device Serial Number	# of Time Slots	SAR (1g)
MHz	Ch.									(W/kg)
836.60	190	GSM 850	GSM	33.67	-0.10	Right	Cheek	2G/3G SAR#1	1	0.370
836.60	190	GSM 850	GSM	33.67	0.01	Right	Tilt	2G/3G SAR#1	1	0.215
836.60	190	GSM 850	GSM	33.67	0.06	Left	Cheek	2G/3G SAR#1	1	0.501
836.60	190	GSM 850	GSM	33.67	0.01	Left	Tilt	2G/3G SAR#1	1	0.237
836.60	190	GSM 850	GPRS	31.64	-0.05	Right	Touch	2G/3G SAR#1	2	0.390
836.60	190	GSM 850	GPRS	31.64	-0.06	Right	Tilt	2G/3G SAR#1	2	0.209
836.60	190	GSM 850	GSPR	31.64	-0.06	Left	Touch	2G/3G SAR#1	2	0.574
836.60	190	GSM 850	GPRS	31.64	-0.04	Left	Tilt	2G/3G SAR#1	2	0.258
ANSI / IEEE C95.1 1992 - SAFETY LIMIT Spatial Peak Uncontrolled Exposure/General Population						Head 1.6 W/kg (mW/g) averaged over 1 gram				

**Table 12-2
WCDMA 850 Head SAR Results**

MEASUREMENT RESULTS									
FREQUENCY		Mode/Band	Conducted Power [dBm]	Power Drift [dB]	Side	Test Position	Device Serial Number	SAR (1g)	
MHz	Ch.							(W/kg)	
836.60	4183	WCDMA 850	23.34	0.00	Right	Cheek	2G/3G SAR#1	0.311	
836.60	4183	WCDMA 850	23.34	-0.03	Right	Tilt	2G/3G SAR#1	0.183	
836.60	4183	WCDMA 850	23.34	0.03	Left	Cheek	2G/3G SAR#1	0.419	
836.60	4183	WCDMA 850	23.34	-0.01	Left	Tilt	2G/3G SAR#1	0.208	
ANSI / IEEE C95.1 1992 - SAFETY LIMIT Spatial Peak Uncontrolled Exposure/General Population					Head 1.6 W/kg (mW/g) averaged over 1 gram				



FCC ID: ZNFE970		SAR EVALUATION REPORT		Reviewed by: Quality Manager
Document S/N: 0Y1207050909-R1.ZNF	Test Dates: 07/05/12 - 08/23/12	DUT Type: Portable Handset		Page 36 of 62

**Table 12-3
GSM 1900 Head SAR Results**

MEASUREMENT RESULTS										
FREQUENCY		Mode/Band	Service	Conducted Power [dBm]	Power Drift [dB]	Side	Test Position	Device Serial Number	# of Time Slots	SAR (1g)
MHz	Ch.									(W/kg)
1880.00	661	GSM 1900	GSM	30.34	-0.03	Right	Cheek	2G3G SAR#2	1	0.211
1880.00	661	GSM 1900	GSM	30.34	0.13	Right	Tilt	2G3G SAR#2	1	0.139
1880.00	661	GSM 1900	GSM	30.34	-0.13	Left	Cheek	2G3G SAR#2	1	0.370
1880.00	661	GSM 1900	GSM	30.34	0.09	Left	Tilt	2G3G SAR#2	1	0.159
1880.00	661	GSM 1900	GPRS	28.42	0.15	Right	Touch	2G3G SAR#2	2	0.287
1880.00	661	GSM 1900	GPRS	28.42	-0.05	Right	Tilt	2G3G SAR#2	2	0.157
1880.00	661	GSM 1900	GPRS	28.42	0.04	Left	Touch	2G3G SAR#2	2	0.452
1880.00	661	GSM 1900	GPRS	28.42	-0.01	Left	Tilt	2G3G SAR#2	2	0.184
ANSI / IEEE C95.1 1992 - SAFETY LIMIT Spatial Peak Uncontrolled Exposure/General Population						Head 1.6 W/kg (mW/g) averaged over 1 gram				



**Table 12-4
WCDMA 1900 Head SAR Results**

MEASUREMENT RESULTS										
FREQUENCY		Mode	Conducted Power [dBm]	Power Drift [dB]	Side	Test Position	Device Serial Number	SAR (1g)		
MHz	Ch.							(W/kg)		
1880.00	9400	WCDMA 1900	23.42	-0.02	Right	Cheek	2G3G SAR#2	0.303		
1880.00	9400	WCDMA 1900	23.42	-0.02	Right	Tilt	2G3G SAR#2	0.161		
1880.00	9400	WCDMA 1900	23.42	-0.12	Left	Cheek	2G3G SAR#2	0.460		
1880.00	9400	WCDMA 1900	23.42	0.03	Left	Tilt	2G3G SAR#2	0.189		
ANSI / IEEE C95.1 1992 - SAFETY LIMIT Spatial Peak Uncontrolled Exposure/General Population						Head 1.6 W/kg (mW/g) averaged over 1 gram				

FCC ID: ZNFE970	 PCTEST ENGINEERING LABORATORY, INC.	SAR EVALUATION REPORT	 LG	Reviewed by: Quality Manager
Document S/N: 0Y1207050909-R1.ZNF	Test Dates: 07/05/12 - 08/23/12	DUT Type: Portable Handset		Page 37 of 62



**Table 12-5
LTE Band 17 Head SAR Results**

MEASUREMENT RESULTS														
FREQUENCY			Mode	Bandwidth [MHz]	Conducted Power [dBm]	Power Drift [dB]	MPR [dB]	Side	Test Position	Modulation	# of RB	RB Offset	Device Serial Number	SAR (1g)
MHz	Ch.	(W/kg)												
710.00	23790	Mid	LTE Band 17	10	22.40	-0.02	1	Right	Cheek	QPSK	25	12	LTE SAR #1	0.203
710.00	23790	Mid	LTE Band 17	10	23.67	0.10	0	Right	Cheek	QPSK	1	0	LTE SAR #1	0.220
710.00	23790	Mid	LTE Band 17	10	23.50	0.17	0	Right	Cheek	QPSK	1	49	LTE SAR #1	0.225
710.00	23790	Mid	LTE Band 17	10	21.41	-0.04	2	Right	Cheek	16 QAM	25	12	LTE SAR #1	0.162
710.00	23790	Mid	LTE Band 17	10	22.62	0.00	1	Right	Cheek	16 QAM	1	0	LTE SAR #1	0.176
710.00	23790	Mid	LTE Band 17	10	22.24	0.10	1	Right	Cheek	16 QAM	1	49	LTE SAR #1	0.184
710.00	23790	Mid	LTE Band 17	10	22.40	0.07	1	Right	Tilt	QPSK	25	12	LTE SAR #1	0.099
710.00	23790	Mid	LTE Band 17	10	23.67	0.12	0	Right	Tilt	QPSK	1	0	LTE SAR #1	0.108
710.00	23790	Mid	LTE Band 17	10	23.50	0.21	0	Right	Tilt	QPSK	1	49	LTE SAR #1	0.129
710.00	23790	Mid	LTE Band 17	10	21.41	0.14	2	Right	Tilt	16 QAM	25	12	LTE SAR #1	0.078
710.00	23790	Mid	LTE Band 17	10	22.62	-0.03	1	Right	Tilt	16 QAM	1	0	LTE SAR #1	0.084
710.00	23790	Mid	LTE Band 17	10	22.24	0.14	1	Right	Tilt	16 QAM	1	49	LTE SAR #1	0.099
710.00	23790	Mid	LTE Band 17	10	22.40	0.06	1	Left	Cheek	QPSK	25	12	LTE SAR #1	0.148
710.00	23790	Mid	LTE Band 17	10	23.67	0.01	0	Left	Cheek	QPSK	1	0	LTE SAR #1	0.153
710.00	23790	Mid	LTE Band 17	10	23.50	0.02	0	Left	Cheek	QPSK	1	49	LTE SAR #1	0.175
710.00	23790	Mid	LTE Band 17	10	21.41	0.13	2	Left	Cheek	16 QAM	25	12	LTE SAR #1	0.119
710.00	23790	Mid	LTE Band 17	10	22.62	-0.10	1	Left	Cheek	16 QAM	1	0	LTE SAR #1	0.125
710.00	23790	Mid	LTE Band 17	10	22.24	-0.06	1	Left	Cheek	16 QAM	1	49	LTE SAR #1	0.143
710.00	23790	Mid	LTE Band 17	10	22.40	0.12	1	Left	Tilt	QPSK	25	12	LTE SAR #1	0.092
710.00	23790	Mid	LTE Band 17	10	23.67	-0.13	0	Left	Tilt	QPSK	1	0	LTE SAR #1	0.087
710.00	23790	Mid	LTE Band 17	10	23.50	0.11	0	Left	Tilt	QPSK	1	49	LTE SAR #1	0.112
710.00	23790	Mid	LTE Band 17	10	21.41	0.06	2	Left	Tilt	16 QAM	25	12	LTE SAR #1	0.078
710.00	23790	Mid	LTE Band 17	10	22.62	0.00	1	Left	Tilt	16 QAM	1	0	LTE SAR #1	0.076
710.00	23790	Mid	LTE Band 17	10	22.24	0.13	1	Left	Tilt	16 QAM	1	49	LTE SAR #1	0.091
ANSI / IEEE C95.1 1992 - SAFETY LIMIT									Head					
Spatial Peak									1.6 W/kg (mW/g)					
Uncontrolled Exposure/General Population									averaged over 1 gram					

FCC ID: ZNFE970	 PCTEST ENGINEERING LABORATORY, INC.	SAR EVALUATION REPORT	 LG	Reviewed by: Quality Manager
Document S/N: 0Y1207050909-R1.ZNF	Test Dates: 07/05/12 - 08/23/12	DUT Type: Portable Handset		Page 38 of 62



**Table 12-6
LTE Band 5 (Cell) Head SAR Results**

MEASUREMENT RESULTS															
FREQUENCY		Mode	Bandwidth [MHz]	Conducted Power [dBm]	Power Drift [dB]	MPR [dB]	Side	Test Position	Modulation	# of RB	RB Offset	Device Serial Number	SAR (1g)		
MHz	Ch.												(W/kg)		
836.50	20525	Mid	LTE Band 5 (Cell)	10	22.26	-0.02	1	Right	Cheek	QPSK	25	12	LTE SAR #1	0.261	
844.00	20600	High	LTE Band 5 (Cell)	10	23.64	0.21	0	Right	Cheek	QPSK	1	0	LTE SAR #1	0.339	
844.00	20600	High	LTE Band 5 (Cell)	10	23.52	-0.05	0	Right	Cheek	QPSK	1	49	LTE SAR #1	0.371	
836.50	20525	Mid	LTE Band 5 (Cell)	10	21.23	-0.07	2	Right	Cheek	16 QAM	25	12	LTE SAR #1	0.203	
844.00	20600	High	LTE Band 5 (Cell)	10	22.44	0.01	1	Right	Cheek	16 QAM	1	0	LTE SAR #1	0.243	
844.00	20600	High	LTE Band 5 (Cell)	10	22.63	0.09	1	Right	Cheek	16 QAM	1	49	LTE SAR #1	0.275	
836.50	20525	Mid	LTE Band 5 (Cell)	10	22.26	-0.06	1	Right	Tilt	QPSK	25	12	LTE SAR #1	0.159	
844.00	20600	High	LTE Band 5 (Cell)	10	23.64	0.17	0	Right	Tilt	QPSK	1	0	LTE SAR #1	0.202	
844.00	20600	High	LTE Band 5 (Cell)	10	23.52	0.02	0	Right	Tilt	QPSK	1	49	LTE SAR #1	0.216	
836.50	20525	Mid	LTE Band 5 (Cell)	10	21.23	0.02	2	Right	Tilt	16 QAM	25	12	LTE SAR #1	0.130	
844.00	20600	High	LTE Band 5 (Cell)	10	22.44	0.05	1	Right	Tilt	16 QAM	1	0	LTE SAR #1	0.145	
844.00	20600	High	LTE Band 5 (Cell)	10	22.63	-0.11	1	Right	Tilt	16 QAM	1	49	LTE SAR #1	0.160	
836.50	20525	Mid	LTE Band 5 (Cell)	10	22.26	0.06	1	Left	Cheek	QPSK	25	12	LTE SAR #1	0.333	
844.00	20600	High	LTE Band 5 (Cell)	10	23.64	0.16	0	Left	Cheek	QPSK	1	0	LTE SAR #1	0.457	
844.00	20600	High	LTE Band 5 (Cell)	10	23.52	0.01	0	Left	Cheek	QPSK	1	49	LTE SAR #1	0.493	
836.50	20525	Mid	LTE Band 5 (Cell)	10	21.23	-0.16	2	Left	Cheek	16 QAM	25	12	LTE SAR #1	0.259	
844.00	20600	High	LTE Band 5 (Cell)	10	22.44	-0.05	1	Left	Cheek	16 QAM	1	0	LTE SAR #1	0.326	
844.00	20600	High	LTE Band 5 (Cell)	10	22.63	-0.14	1	Left	Cheek	16 QAM	1	49	LTE SAR #1	0.360	
836.50	20525	Mid	LTE Band 5 (Cell)	10	22.26	0.00	1	Left	Tilt	QPSK	25	12	LTE SAR #1	0.165	
844.00	20600	High	LTE Band 5 (Cell)	10	23.64	-0.07	0	Left	Tilt	QPSK	1	0	LTE SAR #1	0.221	
844.00	20600	High	LTE Band 5 (Cell)	10	23.52	0.18	0	Left	Tilt	QPSK	1	49	LTE SAR #1	0.247	
836.50	20525	Mid	LTE Band 5 (Cell)	10	21.23	0.05	2	Left	Tilt	16 QAM	25	12	LTE SAR #1	0.128	
844.00	20600	High	LTE Band 5 (Cell)	10	22.44	0.17	1	Left	Tilt	16 QAM	1	0	LTE SAR #1	0.161	
844.00	20600	High	LTE Band 5 (Cell)	10	22.63	-0.02	1	Left	Tilt	16 QAM	1	49	LTE SAR #1	0.176	
ANSI / IEEE C95.1 1992 - SAFETY LIMIT								Head							
Spatial Peak								1.6 W/kg (mW/g)							
Uncontrolled Exposure/General Population								averaged over 1 gram							

FCC ID: ZNFE970		SAR EVALUATION REPORT		Reviewed by: Quality Manager
Document S/N: OY1207050909-R1.ZNF	Test Dates: 07/05/12 - 08/23/12	DUT Type: Portable Handset	Page 39 of 62	



**Table 12-7
LTE Band 4 (AWS) Head SAR Results**

MEASUREMENT RESULTS															
FREQUENCY		Mode	Bandwidth [MHz]	Conducted Power [dBm]	Power Drift [dB]	MPR [dB]	Side	Test Position	Modulation	# of RB	RB Offset	Device Serial Number	SAR (1g)		
MHz	Ch.												(W/kg)		
1732.50	20175	Mid	LTE Band 4 (AWS)	10	22.03	0.05	1	Right	Cheek	QPSK	25	12	LTE SAR #1	0.466	
1715.00	20000	Low	LTE Band 4 (AWS)	10	23.64	-0.12	0	Right	Cheek	QPSK	1	0	LTE SAR #1	0.671	
1715.00	20000	Low	LTE Band 4 (AWS)	10	23.45	0.07	0	Right	Cheek	QPSK	1	49	LTE SAR #1	0.644	
1732.50	20175	Mid	LTE Band 4 (AWS)	10	21.03	0.12	2	Right	Cheek	16 QAM	25	12	LTE SAR #1	0.375	
1715.00	20000	Low	LTE Band 4 (AWS)	10	22.42	-0.10	1	Right	Cheek	16 QAM	1	0	LTE SAR #1	0.540	
1715.00	20000	Low	LTE Band 4 (AWS)	10	21.99	0.06	1	Right	Cheek	16 QAM	1	49	LTE SAR #1	0.506	
1732.50	20175	Mid	LTE Band 4 (AWS)	10	22.03	0.06	1	Right	Tilt	QPSK	25	12	LTE SAR #1	0.202	
1715.00	20000	Low	LTE Band 4 (AWS)	10	23.64	0.02	0	Right	Tilt	QPSK	1	0	LTE SAR #1	0.306	
1715.00	20000	Low	LTE Band 4 (AWS)	10	23.45	0.07	0	Right	Tilt	QPSK	1	49	LTE SAR #1	0.310	
1732.50	20175	Mid	LTE Band 4 (AWS)	10	21.03	0.18	2	Right	Tilt	16 QAM	25	12	LTE SAR #1	0.171	
1715.00	20000	Low	LTE Band 4 (AWS)	10	22.42	0.01	1	Right	Tilt	16 QAM	1	0	LTE SAR #1	0.242	
1715.00	20000	Low	LTE Band 4 (AWS)	10	21.99	-0.06	1	Right	Tilt	16 QAM	1	49	LTE SAR #1	0.235	
1732.50	20175	Mid	LTE Band 4 (AWS)	10	22.03	0.01	1	Left	Cheek	QPSK	25	12	LTE SAR #1	0.254	
1715.00	20000	Low	LTE Band 4 (AWS)	10	23.64	0.04	0	Left	Cheek	QPSK	1	0	LTE SAR #1	0.329	
1715.00	20000	Low	LTE Band 4 (AWS)	10	23.45	-0.15	0	Left	Cheek	QPSK	1	49	LTE SAR #1	0.318	
1732.50	20175	Mid	LTE Band 4 (AWS)	10	21.03	0.01	2	Left	Cheek	16 QAM	25	12	LTE SAR #1	0.213	
1715.00	20000	Low	LTE Band 4 (AWS)	10	22.42	-0.02	1	Left	Cheek	16 QAM	1	0	LTE SAR #1	0.261	
1715.00	20000	Low	LTE Band 4 (AWS)	10	21.99	0.05	1	Left	Cheek	16 QAM	1	49	LTE SAR #1	0.252	
1732.50	20175	Mid	LTE Band 4 (AWS)	10	22.03	-0.10	1	Left	Tilt	QPSK	25	12	LTE SAR #1	0.182	
1715.00	20000	Low	LTE Band 4 (AWS)	10	23.64	-0.03	0	Left	Tilt	QPSK	1	0	LTE SAR #1	0.254	
1715.00	20000	Low	LTE Band 4 (AWS)	10	23.45	0.13	0	Left	Tilt	QPSK	1	49	LTE SAR #1	0.232	
1732.50	20175	Mid	LTE Band 4 (AWS)	10	21.03	0.04	2	Left	Tilt	16 QAM	25	12	LTE SAR #1	0.144	
1715.00	20000	Low	LTE Band 4 (AWS)	10	22.42	-0.05	1	Left	Tilt	16 QAM	1	0	LTE SAR #1	0.206	
1715.00	20000	Low	LTE Band 4 (AWS)	10	21.99	-0.02	1	Left	Tilt	16 QAM	1	49	LTE SAR #1	0.161	
ANSI / IEEE C95.1 1992 - SAFETY LIMIT								Head							
Spatial Peak								1.6 W/kg (mW/g)							
Uncontrolled Exposure/General Population								averaged over 1 gram							

FCC ID: ZNFE970	 PCTEST ENGINEERING LABORATORY, INC.	SAR EVALUATION REPORT	 LG	Reviewed by: Quality Manager
Document S/N: 0Y1207050909-R1.ZNF	Test Dates: 07/05/12 - 08/23/12	DUT Type: Portable Handset		Page 40 of 62

**Table 12-8
LTE Band 2 (PCS) Head SAR Results**

MEASUREMENT RESULTS															
FREQUENCY		Mode	Bandwidth [MHz]	Conducted Power [dBm]	Power Drift [dB]	MPR [dB]	Side	Test Position	Modulation	# of RB	RB Offset	Device Serial Number	SAR (1g)		
MHz	Ch.												(W/kg)		
1880.00	18900	Mid	LTE Band 2 (PCS)	10	21.71	0.05	1	Right	Cheek	QPSK	25	12	LTE SAR #3	0.210	
1855.00	18650	Low	LTE Band 2 (PCS)	10	23.51	0.14	0	Right	Cheek	QPSK	1	0	LTE SAR #3	0.276	
1855.00	18650	Low	LTE Band 2 (PCS)	10	23.47	-0.02	0	Right	Cheek	QPSK	1	49	LTE SAR #3	0.285	
1880.00	18900	Mid	LTE Band 2 (PCS)	10	20.75	0.04	2	Right	Cheek	16 QAM	25	12	LTE SAR #3	0.170	
1905.00	19150	High	LTE Band 2 (PCS)	10	22.19	-0.01	1	Right	Cheek	16 QAM	1	0	LTE SAR #3	0.255	
1905.00	19150	High	LTE Band 2 (PCS)	10	22.29	-0.05	1	Right	Cheek	16 QAM	1	49	LTE SAR #3	0.232	
1880.00	18900	Mid	LTE Band 2 (PCS)	10	21.71	0.21	1	Right	Tilt	QPSK	25	12	LTE SAR #3	0.126	
1855.00	18650	Low	LTE Band 2 (PCS)	10	23.51	-0.01	0	Right	Tilt	QPSK	1	0	LTE SAR #3	0.182	
1855.00	18650	Low	LTE Band 2 (PCS)	10	23.47	0.07	0	Right	Tilt	QPSK	1	49	LTE SAR #3	0.172	
1880.00	18900	Mid	LTE Band 2 (PCS)	10	20.75	-0.01	2	Right	Tilt	16 QAM	25	12	LTE SAR #3	0.100	
1905.00	19150	High	LTE Band 2 (PCS)	10	22.19	0.06	1	Right	Tilt	16 QAM	1	0	LTE SAR #3	0.184	
1905.00	19150	High	LTE Band 2 (PCS)	10	22.29	0.05	1	Right	Tilt	16 QAM	1	49	LTE SAR #3	0.167	
1880.00	18900	Mid	LTE Band 2 (PCS)	10	21.71	-0.15	1	Left	Cheek	QPSK	25	12	LTE SAR #3	0.476	
1855.00	18650	Low	LTE Band 2 (PCS)	10	23.51	-0.02	0	Left	Cheek	QPSK	1	0	LTE SAR #3	0.606	
1855.00	18650	Low	LTE Band 2 (PCS)	10	23.47	0.13	0	Left	Cheek	QPSK	1	49	LTE SAR #3	0.642	
1880.00	18900	Mid	LTE Band 2 (PCS)	10	20.75	-0.11	2	Left	Cheek	16 QAM	25	12	LTE SAR #3	0.317	
1905.00	19150	High	LTE Band 2 (PCS)	10	22.19	-0.14	1	Left	Cheek	16 QAM	1	0	LTE SAR #3	0.591	
1905.00	19150	High	LTE Band 2 (PCS)	10	22.29	-0.07	1	Left	Cheek	16 QAM	1	49	LTE SAR #3	0.529	
1880.00	18900	Mid	LTE Band 2 (PCS)	10	21.71	-0.05	1	Left	Tilt	QPSK	25	12	LTE SAR #3	0.162	
1855.00	18650	Low	LTE Band 2 (PCS)	10	23.51	-0.12	0	Left	Tilt	QPSK	1	0	LTE SAR #3	0.204	
1855.00	18650	Low	LTE Band 2 (PCS)	10	23.47	0.05	0	Left	Tilt	QPSK	1	49	LTE SAR #3	0.208	
1880.00	18900	Mid	LTE Band 2 (PCS)	10	20.75	0.05	2	Left	Tilt	16 QAM	25	12	LTE SAR #3	0.127	
1905.00	19150	High	LTE Band 2 (PCS)	10	22.19	0.11	1	Left	Tilt	16 QAM	1	0	LTE SAR #3	0.207	
1905.00	19150	High	LTE Band 2 (PCS)	10	22.29	0.03	1.0	Left	Tilt	16 QAM	1	49	LTE SAR #3	0.186	
ANSI / IEEE C95.1 1992 - SAFETY LIMIT								Head							
Spatial Peak								1.6 W/kg (mW/g)							
Uncontrolled Exposure/General Population								averaged over 1 gram							

FCC ID: ZNFE970	 PCTEST ENGINEERING LABORATORY, INC.	SAR EVALUATION REPORT	 LG	Reviewed by: Quality Manager
Document S/N: 0Y1207050909-R1.ZNF	Test Dates: 07/05/12 - 08/23/12	DUT Type: Portable Handset		Page 41 of 62

**Table 12-9
2.4 GHz WLAN Head SAR Results**



MEASUREMENT RESULTS										
FREQUENCY		Mode	Service	Conducted Power [dBm]	Power Drift [dB]	Side	Test Position	Device Serial Number	Data Rate (Mbps)	SAR (1g)
MHz	Ch.									(W/kg)
2412	1	IEEE 802.11b	DSSS	16.27	-0.07	Right	Cheek	WIFI SAR #1	1	0.139
2412	1	IEEE 802.11b	DSSS	16.27	0.15	Right	Tilt	WIFI SAR #1	1	0.071
2412	1	IEEE 802.11b	DSSS	16.27	-0.10	Left	Cheek	WIFI SAR #1	1	0.330
2412	1	IEEE 802.11b	DSSS	16.27	0.18	Left	Tilt	WIFI SAR #1	1	0.073
ANSI / IEEE C95.1 1992 - SAFETY LIMIT Spatial Peak Uncontrolled Exposure/General Population						Head 1.6 W/kg (mW/g) averaged over 1 gram				

**Table 12-10
5.8 GHz WLAN Head SAR Results**

MEASUREMENT RESULTS										
FREQUENCY		Mode	Service	Conducted Power [dBm]	Power Drift [dB]	Side	Test Position	Device Serial Number	Data Rate (Mbps)	SAR (1g)
MHz	Ch.									(W/kg)
5785	157	IEEE 802.11a	OFDM	14.26	0.13	Right	Cheek	WIFI SAR #1	6	0.007
5785	157	IEEE 802.11a	OFDM	14.26	0.12	Right	Tilt	WIFI SAR #1	6	0.009
5785	157	IEEE 802.11a	OFDM	14.26	0.21	Left	Cheek	WIFI SAR #1	6	0.061
5785	157	IEEE 802.11a	OFDM	14.26	-0.14	Left	Tilt	WIFI SAR #1	6	0.010
ANSI / IEEE C95.1 1992 - SAFETY LIMIT Spatial Peak Uncontrolled Exposure/General Population						Head 1.6 W/kg (mW/g) averaged over 1 gram				

**Table 12-11
5.2 GHz WLAN Head SAR Results**

MEASUREMENT RESULTS										
FREQUENCY		Mode	Service	Conducted Power [dBm]	Power Drift [dB]	Side	Test Position	Device Serial Number	Data Rate (Mbps)	SAR (1g)
MHz	Ch.									(W/kg)
5200	40	IEEE 802.11a	OFDM	14.57	0.15	Right	Cheek	WIFI SAR #1	6	0.047
5200	40	IEEE 802.11a	OFDM	14.57	0.16	Right	Tilt	WIFI SAR #1	6	0.037
5200	40	IEEE 802.11a	OFDM	14.57	0.19	Left	Cheek	WIFI SAR #1	6	0.099
5200	40	IEEE 802.11a	OFDM	14.57	0.18	Left	Tilt	WIFI SAR #1	6	0.029
ANSI / IEEE C95.1 1992 - SAFETY LIMIT Spatial Peak Uncontrolled Exposure/General Population						Head 1.6 W/kg (mW/g) averaged over 1 gram				

FCC ID: ZNFE970	 PCTEST ENGINEERING LABORATORY, INC.	SAR EVALUATION REPORT	 LG	Reviewed by: Quality Manager
Document S/N: OY1207050909-R1.ZNF	Test Dates: 07/05/12 - 08/23/12	DUT Type: Portable Handset		Page 42 of 62

**Table 12-12
5.3 GHz WLAN Head SAR Results**

MEASUREMENT RESULTS										
FREQUENCY		Mode	Service	Conducted Power [dBm]	Power Drift [dB]	Side	Test Position	Device Serial Number	Data Rate (Mbps)	SAR (1g)
MHz	Ch.									(W/kg)
5260	52	IEEE 802.11a	OFDM	14.53	0.14	Right	Cheek	WIFI SAR #1	6	0.055
5260	52	IEEE 802.11a	OFDM	14.53	0.13	Right	Tilt	WIFI SAR #1	6	0.048
5260	52	IEEE 802.11a	OFDM	14.53	0.17	Left	Cheek	WIFI SAR #1	6	0.195
5260	52	IEEE 802.11a	OFDM	14.53	-0.08	Left	Tilt	WIFI SAR #1	6	0.042
ANSI / IEEE C95.1 1992 - SAFETY LIMIT Spatial Peak Uncontrolled Exposure/General Population						Head 1.6 W/kg (mW/g) averaged over 1 gram				



**Table 12-13
5.5 - 5.7 GHz WLAN Head SAR Results**

MEASUREMENT RESULTS										
FREQUENCY		Mode	Service	Conducted Power [dBm]	Power Drift [dB]	Side	Test Position	Device Serial Number	Data Rate (Mbps)	SAR (1g)
MHz	Ch.									(W/kg)
5540	108	IEEE 802.11a	OFDM	14.47	0.14	Right	Cheek	WIFI SAR #1	6	0.030
5540	108	IEEE 802.11a	OFDM	14.47	0.12	Right	Tilt	WIFI SAR #1	6	0.045
5540	108	IEEE 802.11a	OFDM	14.47	0.09	Left	Cheek	WIFI SAR #1	6	0.110
5540	108	IEEE 802.11a	OFDM	14.47	-0.14	Left	Tilt	WIFI SAR #1	6	0.019
ANSI / IEEE C95.1 1992 - SAFETY LIMIT Spatial Peak Uncontrolled Exposure/General Population						Head 1.6 W/kg (mW/g) averaged over 1 gram				

12.2 Standalone Body-Worn SAR Data



**Table 12-14
Licensed Transmitter Body-Worn SAR Results**

MEASUREMENT RESULTS										
FREQUENCY		Mode	Service	Conducted Power [dBm]	Power Drift [dB]	Spacing	Device Serial Number	# of Time Slots	Side	SAR (1g)
MHz	Ch.									(W/kg)
836.60	190	GSM 850	GSM	33.67	-0.04	1.0 cm	2G/3G SAR#1	1	back	0.580
836.60	190	GSM 850	GPRS	31.64	-0.02	1.0 cm	2G/3G SAR#1	2	back	0.730
836.60	4183	WCDMA 850	RMC	23.34	0.02	1.0 cm	2G/3G SAR#1	N/A	back	0.538
1880.00	661	GSM 1900	GSM	30.34	0.00	1.0 cm	2G/3G SAR#1	1	back	0.420
1880.00	661	GSM 1900	GPRS	28.42	-0.05	1.0 cm	2G/3G SAR#1	2	back	0.522
1880.00	9400	WCDMA 1900	RMC	23.42	-0.02	1.0 cm	2G/3G SAR#1	N/A	back	0.575
ANSI / IEEE C95.1 1992 - SAFETY LIMIT Spatial Peak Uncontrolled Exposure/General Population						Body 1.6 W/kg (mW/g) averaged over 1 gram				

FCC ID: ZNFE970	 PCTEST ENGINEERING LABORATORY, INC.	SAR EVALUATION REPORT	 LG	Reviewed by: Quality Manager
Document S/N: 0Y1207050909-R1.ZNF	Test Dates: 07/05/12 - 08/23/12	DUT Type: Portable Handset		Page 43 of 62

**Table 12-15
LTE Body-Worn SAR Results**

MEASUREMENT RESULTS														
FREQUENCY		Mode	Bandwidth [MHz]	Conducted Power [dBm]	Power Drift [dB]	MPR [dB]	Device Serial Number	Modulation	# of RB	RB Offset	Spacing	Side	SAR (1g)	
MHz	Ch.												(W/kg)	
710.00	23790	Mid	LTE Band 17	10	22.40	-0.05	1	LTE SAR #1	QPSK	25	12	1.0 cm	back	0.365
710.00	23790	Mid	LTE Band 17	10	23.67	0.02	0	LTE SAR #1	QPSK	1	0	1.0 cm	back	0.447
710.00	23790	Mid	LTE Band 17	10	23.50	-0.03	0	LTE SAR #1	QPSK	1	49	1.0 cm	back	0.439
710.00	23790	Mid	LTE Band 17	10	21.41	0.00	2	LTE SAR #1	16 QAM	25	12	1.0 cm	back	0.287
710.00	23790	Mid	LTE Band 17	10	22.62	-0.05	1	LTE SAR #1	16 QAM	1	0	1.0 cm	back	0.359
710.00	23790	Mid	LTE Band 17	10	22.24	0.00	1	LTE SAR #1	16 QAM	1	49	1.0 cm	back	0.354
836.50	20525	Mid	LTE Band 5 (Cell)	10	22.26	0.19	1	LTE SAR #1	QPSK	25	12	1.0 cm	back	0.441
844.00	20600	High	LTE Band 5 (Cell)	10	23.64	0.14	0	LTE SAR #1	QPSK	1	0	1.0 cm	back	0.553
844.00	20600	High	LTE Band 5 (Cell)	10	23.52	0.04	0	LTE SAR #1	QPSK	1	49	1.0 cm	back	0.638
836.50	20525	Mid	LTE Band 5 (Cell)	10	21.23	-0.06	2	LTE SAR #1	16 QAM	25	12	1.0 cm	back	0.337
844.00	20600	High	LTE Band 5 (Cell)	10	22.44	0.05	1	LTE SAR #1	16 QAM	1	0	1.0 cm	back	0.443
844.00	20600	High	LTE Band 5 (Cell)	10	22.63	-0.08	1	LTE SAR #1	16 QAM	1	49	1.0 cm	back	0.515
1715.00	20000	Low	LTE Band 4 (AWS)	10	22.04	-0.05	1	LTE SAR #1	QPSK	25	12	1.0 cm	back	0.935
1732.50	20175	Mid	LTE Band 4 (AWS)	10	22.03	0.13	1	LTE SAR #1	QPSK	25	12	1.0 cm	back	0.841
1750.00	20350	High	LTE Band 4 (AWS)	10	22.16	-0.01	1	LTE SAR #1	QPSK	25	12	1.0 cm	back	0.760
1715.00	20000	Low	LTE Band 4 (AWS)	10	23.64	0.01	0	LTE SAR #1	QPSK	1	0	1.0 cm	back	1.220
1715.00	20000	Low	LTE Band 4 (AWS)	10	23.45	0.03	0	LTE SAR #1	QPSK	1	49	1.0 cm	back	1.220
1715.00	20000	Low	LTE Band 4 (AWS)	10	20.92	-0.12	2	LTE SAR #1	16 QAM	25	12	1.0 cm	back	0.755
1715.00	20000	Low	LTE Band 4 (AWS)	10	22.42	0.00	1	LTE SAR #1	16 QAM	1	0	1.0 cm	back	0.911
1715.00	20000	Low	LTE Band 4 (AWS)	10	21.99	0.02	1	LTE SAR #1	16 QAM	1	49	1.0 cm	back	0.918
1880.00	18900	Mid	LTE Band 2 (PCS)	10	21.71	0.02	1	LTE SAR #3	QPSK	25	12	1.0 cm	back	0.432
1855.00	18650	Low	LTE Band 2 (PCS)	10	23.51	-0.14	0	LTE SAR #3	QPSK	1	0	1.0 cm	back	0.623
1855.00	18650	Low	LTE Band 2 (PCS)	10	23.47	-0.02	0	LTE SAR #3	QPSK	1	49	1.0 cm	back	0.607
1880.00	18900	Mid	LTE Band 2 (PCS)	10	20.75	0.02	2	LTE SAR #3	16 QAM	25	12	1.0 cm	back	0.342
1905.00	19150	High	LTE Band 2 (PCS)	10	22.19	-0.08	1	LTE SAR #3	16 QAM	1	0	1.0 cm	back	0.464
1905.00	19150	High	LTE Band 2 (PCS)	10	22.29	0.05	1	LTE SAR #3	16 QAM	1	49	1.0 cm	back	0.416
ANSI / IEEE C95.1 1992 - SAFETY LIMIT								Body						
Spatial Peak								1.6 W/kg (mW/g)						
Uncontrolled Exposure/General Population								averaged over 1 gram						

FCC ID: ZNFE970	 PCTEST ENGINEERING LABORATORY, INC.	SAR EVALUATION REPORT	 LG	Reviewed by: Quality Manager
Document S/N: 0Y1207050909-R1.ZNF	Test Dates: 07/05/12 - 08/23/12	DUT Type: Portable Handset	Page 44 of 62	

**Table 12-16
WLAN Body-Worn SAR Results**

MEASUREMENT RESULTS										
FREQUENCY		Mode	Service	Conducted Power [dBm]	Power Drift [dB]	Spacing	Device Serial Number	Data Rate (Mbps)	Side	SAR (1g)
MHz	Ch.									(W/kg)
2412	1	IEEE 802.11b	DSSS	16.27	-0.16	1.0 cm	WIFI SAR #1	1	back	0.494
5785	157	IEEE 802.11a	OFDM	14.26	0.15	1.0 cm	WIFI SAR #1	6	back	0.126
5200	40	IEEE 802.11a	OFDM	14.57	-0.12	1.0 cm	WIFI SAR #1	6	back	0.356
5220	44	IEEE 802.11a	OFDM	14.48	0.04	1.0 cm	WIFI SAR #1	6	back	0.424
5260	52	IEEE 802.11a	OFDM	14.53	-0.20	1.0 cm	WIFI SAR #1	6	back	0.333
5540	108	IEEE 802.11a	OFDM	14.47	-0.19	1.0 cm	WIFI SAR #1	6	back	0.251
ANSI / IEEE C95.1 1992 - SAFETY LIMIT Spatial Peak Uncontrolled Exposure/General Population						Body 1.6 W/kg (mW/g) averaged over 1 gram				

12.3 Standalone Wireless Router SAR Data

**Table 12-17
Licensed Transmitter Hotspot SAR Data**

MEASUREMENT RESULTS										
FREQUENCY		Mode	Service	Conducted Power [dBm]	Power Drift [dB]	Spacing	Device Serial Number	# of GPRS Slots	Side	SAR (1g)
MHz	Ch.									(W/kg)
836.60	190	GSM 850	GPRS	31.64	-0.02	1.0 cm	2G/3G SAR#1	2	back	0.730
836.60	190	GSM 850	GPRS	31.64	-0.02	1.0 cm	2G/3G SAR#1	2	front	0.736
836.60	190	GSM 850	GPRS	31.64	-0.12	1.0 cm	2G/3G SAR#1	2	bottom	0.186
836.60	190	GSM 850	GPRS	31.64	0.08	1.0 cm	2G/3G SAR#1	2	left	0.728
836.60	4183	WCDMA 850	RMC	23.34	0.02	1.0 cm	2G/3G SAR#1	N/A	back	0.538
836.60	4183	WCDMA 850	RMC	23.34	-0.02	1.0 cm	2G/3G SAR#1	N/A	front	0.451
836.60	4183	WCDMA 850	RMC	23.34	-0.12	1.0 cm	2G/3G SAR#1	N/A	bottom	0.186
836.60	4183	WCDMA 850	RMC	23.34	0.05	1.0 cm	2G/3G SAR#1	N/A	left	0.630
1880.00	661	GSM 1900	GPRS	28.42	-0.05	1.0 cm	2G/3G SAR#1	2	back	0.522
1880.00	661	GSM 1900	GPRS	28.42	-0.04	1.0 cm	2G/3G SAR#1	2	front	0.392
1880.00	661	GSM 1900	GPRS	28.42	0.21	1.0 cm	2G/3G SAR#1	2	bottom	0.200
1880.00	661	GSM 1900	GPRS	28.42	0.05	1.0 cm	2G/3G SAR#1	2	left	0.360
1880.00	9400	WCDMA 1900	RMC	23.42	-0.02	1.0 cm	2G/3G SAR#1	N/A	back	0.575
1880.00	9400	WCDMA 1900	RMC	23.42	0.00	1.0 cm	2G/3G SAR#1	N/A	front	0.432
1880.00	9400	WCDMA 1900	RMC	23.42	0.08	1.0 cm	2G/3G SAR#1	N/A	bottom	0.153
1880.00	9400	WCDMA 1900	RMC	23.42	0.02	1.0 cm	2G/3G SAR#1	N/A	left	0.235
ANSI / IEEE C95.1 1992 - SAFETY LIMIT Spatial Peak Uncontrolled Exposure/General Population						Body 1.6 W/kg (mW/g) averaged over 1 gram				



FCC ID: ZNFE970	 PCTEST ENGINEERING LABORATORY, INC.	SAR EVALUATION REPORT	 LG	Reviewed by: Quality Manager
Document S/N: OY1207050909-R1.ZNF	Test Dates: 07/05/12 - 08/23/12	DUT Type: Portable Handset		Page 45 of 62

Table 12-18
LTE Band 17 Hotspot SAR Data

MEASUREMENT RESULTS														
FREQUENCY			Mode	Bandwidth [MHz]	Conducted Power [dBm]	Power Drift [dB]	MPR [dB]	Device Serial Number	Modulation	# of RB	RB Offset	Spacing	Side	SAR (1g)
MHz	Ch.	High												(W/kg)
710.00	23790	Mid	LTE Band 17	10	22.40	-0.05	1	LTE SAR #1	QPSK	25	12	1.0 cm	back	0.365
710.00	23790	Mid	LTE Band 17	10	23.67	0.02	0	LTE SAR #1	QPSK	1	0	1.0 cm	back	0.447
710.00	23790	Mid	LTE Band 17	10	23.50	-0.03	0	LTE SAR #1	QPSK	1	49	1.0 cm	back	0.439
710.00	23790	Mid	LTE Band 17	10	21.41	0.00	2	LTE SAR #1	16 QAM	25	12	1.0 cm	back	0.287
710.00	23790	Mid	LTE Band 17	10	22.62	-0.05	1	LTE SAR #1	16 QAM	1	0	1.0 cm	back	0.359
710.00	23790	Mid	LTE Band 17	10	22.24	0.00	1	LTE SAR #1	16 QAM	1	49	1.0 cm	back	0.354
710.00	23790	Mid	LTE Band 17	10	22.40	0.01	1	LTE SAR #1	QPSK	25	12	1.0 cm	front	0.211
710.00	23790	Mid	LTE Band 17	10	23.67	0.01	0	LTE SAR #1	QPSK	1	0	1.0 cm	front	0.245
710.00	23790	Mid	LTE Band 17	10	23.50	0.00	0	LTE SAR #1	QPSK	1	49	1.0 cm	front	0.255
710.00	23790	Mid	LTE Band 17	10	21.41	-0.03	2	LTE SAR #1	16 QAM	25	12	1.0 cm	front	0.168
710.00	23790	Mid	LTE Band 17	10	22.62	0.19	1	LTE SAR #1	16 QAM	1	0	1.0 cm	front	0.197
710.00	23790	Mid	LTE Band 17	10	22.24	0.03	1	LTE SAR #1	16 QAM	1	49	1.0 cm	front	0.206
710.00	23790	Mid	LTE Band 17	10	22.40	-0.06	1	LTE SAR #1	QPSK	25	12	1.0 cm	bottom	0.124
710.00	23790	Mid	LTE Band 17	10	23.67	0.10	0	LTE SAR #1	QPSK	1	0	1.0 cm	bottom	0.142
710.00	23790	Mid	LTE Band 17	10	23.50	-0.04	0	LTE SAR #1	QPSK	1	49	1.0 cm	bottom	0.150
710.00	23790	Mid	LTE Band 17	10	21.41	0.07	2	LTE SAR #1	16 QAM	25	12	1.0 cm	bottom	0.098
710.00	23790	Mid	LTE Band 17	10	22.62	-0.11	1	LTE SAR #1	16 QAM	1	0	1.0 cm	bottom	0.117
710.00	23790	Mid	LTE Band 17	10	22.24	0.06	1	LTE SAR #1	16 QAM	1	49	1.0 cm	bottom	0.123
710.00	23790	Mid	LTE Band 17	10	22.40	-0.04	1	LTE SAR #1	QPSK	25	12	1.0 cm	right	0.312
710.00	23790	Mid	LTE Band 17	10	23.67	0.07	0	LTE SAR #1	QPSK	1	0	1.0 cm	right	0.395
710.00	23790	Mid	LTE Band 17	10	23.50	-0.09	0	LTE SAR #1	QPSK	1	49	1.0 cm	right	0.364
710.00	23790	Mid	LTE Band 17	10	21.41	0.12	2	LTE SAR #1	16 QAM	25	12	1.0 cm	right	0.241
710.00	23790	Mid	LTE Band 17	10	22.62	0.00	1	LTE SAR #1	16 QAM	1	0	1.0 cm	right	0.314
710.00	23790	Mid	LTE Band 17	10	22.24	0.04	1	LTE SAR #1	16 QAM	1	49	1.0 cm	right	0.297
ANSI / IEEE C95.1 1992 - SAFETY LIMIT Spatial Peak Uncontrolled Exposure/General Population								Body 1.6 W/kg (mW/g) averaged over 1 gram						





FCC ID: ZNFE970	 PCTEST ENGINEERING LABORATORY, INC.	SAR EVALUATION REPORT	 LG	Reviewed by: Quality Manager
Document S/N: 0Y1207050909-R1.ZNF	Test Dates: 07/05/12 - 08/23/12	DUT Type: Portable Handset		Page 46 of 62



Table 12-19
LTE Band 5 (Cell) Hotspot SAR Data

MEASUREMENT RESULTS														
FREQUENCY		Mode	Bandwidth [MHz]	Conducted Power [dBm]	Power Drift [dB]	MPR [dB]	Device Serial Number	Modulation	# of RB	RB Offset	Spacing	Side	SAR (1g)	
MHz	Ch.												(W/kg)	
836.50	20525	Mid	LTE Band 5 (Cell)	10	22.26	0.19	1	LTE SAR #1	QPSK	25	12	1.0 cm	back	0.441
844.00	20600	High	LTE Band 5 (Cell)	10	23.64	0.14	0	LTE SAR #1	QPSK	1	0	1.0 cm	back	0.553
844.00	20600	High	LTE Band 5 (Cell)	10	23.52	0.04	0	LTE SAR #1	QPSK	1	49	1.0 cm	back	0.638
836.50	20525	Mid	LTE Band 5 (Cell)	10	21.23	-0.06	2	LTE SAR #1	16 QAM	25	12	1.0 cm	back	0.337
844.00	20600	High	LTE Band 5 (Cell)	10	22.44	0.05	1	LTE SAR #1	16 QAM	1	0	1.0 cm	back	0.443
844.00	20600	High	LTE Band 5 (Cell)	10	22.63	-0.08	1	LTE SAR #1	16 QAM	1	49	1.0 cm	back	0.515
836.50	20525	Mid	LTE Band 5 (Cell)	10	22.26	-0.01	1	LTE SAR #1	QPSK	25	12	1.0 cm	front	0.367
844.00	20600	High	LTE Band 5 (Cell)	10	23.64	-0.02	0	LTE SAR #1	QPSK	1	0	1.0 cm	front	0.459
844.00	20600	High	LTE Band 5 (Cell)	10	23.52	-0.01	0	LTE SAR #1	QPSK	1	49	1.0 cm	front	0.539
836.50	20525	Mid	LTE Band 5 (Cell)	10	21.23	-0.06	2	LTE SAR #1	16 QAM	25	12	1.0 cm	front	0.309
844.00	20600	High	LTE Band 5 (Cell)	10	22.44	0.06	1	LTE SAR #1	16 QAM	1	0	1.0 cm	front	0.372
844.00	20600	High	LTE Band 5 (Cell)	10	22.63	-0.11	1	LTE SAR #1	16 QAM	1	49	1.0 cm	front	0.443
836.50	20525	Mid	LTE Band 5 (Cell)	10	22.26	0.03	1	LTE SAR #1	QPSK	25	12	1.0 cm	bottom	0.140
844.00	20600	High	LTE Band 5 (Cell)	10	23.64	0.08	0	LTE SAR #1	QPSK	1	0	1.0 cm	bottom	0.167
844.00	20600	High	LTE Band 5 (Cell)	10	23.52	0.10	0	LTE SAR #1	QPSK	1	49	1.0 cm	bottom	0.257
836.50	20525	Mid	LTE Band 5 (Cell)	10	21.23	0.13	2	LTE SAR #1	16 QAM	25	12	1.0 cm	bottom	0.112
844.00	20600	High	LTE Band 5 (Cell)	10	22.44	0.19	1	LTE SAR #1	16 QAM	1	0	1.0 cm	bottom	0.130
844.00	20600	High	LTE Band 5 (Cell)	10	22.63	0.19	1	LTE SAR #1	16 QAM	1	49	1.0 cm	bottom	0.225
836.50	20525	Mid	LTE Band 5 (Cell)	10	22.26	-0.01	1	LTE SAR #1	QPSK	25	12	1.0 cm	left	0.568
844.00	20600	High	LTE Band 5 (Cell)	10	23.64	0.01	0	LTE SAR #1	QPSK	1	0	1.0 cm	left	0.679
844.00	20600	High	LTE Band 5 (Cell)	10	23.52	0.07	0	LTE SAR #1	QPSK	1	49	1.0 cm	left	0.726
836.50	20525	Mid	LTE Band 5 (Cell)	10	21.23	-0.01	2	LTE SAR #1	16 QAM	25	12	1.0 cm	left	0.471
844.00	20600	High	LTE Band 5 (Cell)	10	22.44	0.01	1	LTE SAR #1	16 QAM	1	0	1.0 cm	left	0.524
844.00	20600	High	LTE Band 5 (Cell)	10	22.63	0.02	1	LTE SAR #1	16 QAM	1	49	1.0 cm	left	0.606
ANSI / IEEE C95.1 1992 - SAFETY LIMIT								Body						
Spatial Peak								1.6 W/kg (mW/g)						
Uncontrolled Exposure/General Population								averaged over 1 gram						

FCC ID: ZNFE970	 PCTEST ENGINEERING LABORATORY, INC.	SAR EVALUATION REPORT		Reviewed by: Quality Manager
Document S/N: 0Y1207050909-R1.ZNF	Test Dates: 07/05/12 - 08/23/12	DUT Type: Portable Handset	Page 47 of 62	

**Table 12-20
LTE Band 4 (AWS) Hotspot SAR Data**

MEASUREMENT RESULTS														
FREQUENCY		Mode	Bandwidth [MHz]	Conducted Power [dBm]	Power Drift [dB]	MPR [dB]	Device Serial Number	Modulation	# of RB	RB Offset	Spacing	Side	SAR (1g)	
MHz	Ch.												(W/kg)	
1715.00	20000	Low	LTE Band 4 (AWS)	10	22.04	-0.05	1.0	LTE SAR #1	QPSK	25	12	1.0 cm	back	0.935
1732.50	20175	Mid	LTE Band 4 (AWS)	10	22.03	0.13	1.0	LTE SAR #1	QPSK	25	12	1.0 cm	back	0.841
1750.00	20350	High	LTE Band 4 (AWS)	10	22.16	-0.01	1.0	LTE SAR #1	QPSK	25	12	1.0 cm	back	0.760
1715.00	20000	Low	LTE Band 4 (AWS)	10	23.64	0.01	0.0	LTE SAR #1	QPSK	1	0	1.0 cm	back	1.220
1715.00	20000	Low	LTE Band 4 (AWS)	10	23.45	0.03	0.0	LTE SAR #1	QPSK	1	49	1.0 cm	back	1.220
1715.00	20000	Low	LTE Band 4 (AWS)	10	20.92	-0.12	2.0	LTE SAR #1	16 QAM	25	12	1.0 cm	back	0.755
1715.00	20000	Low	LTE Band 4 (AWS)	10	22.42	0.00	1.0	LTE SAR #1	16 QAM	1	0	1.0 cm	back	0.911
1715.00	20000	Low	LTE Band 4 (AWS)	10	21.99	0.02	1.0	LTE SAR #1	16 QAM	1	49	1.0 cm	back	0.918
1732.50	20175	Mid	LTE Band 4 (AWS)	10	22.03	0.07	1.0	LTE SAR #1	QPSK	25	12	1.0 cm	front	0.432
1715.00	20000	Low	LTE Band 4 (AWS)	10	23.64	-0.04	0.0	LTE SAR #1	QPSK	1	0	1.0 cm	front	0.640
1715.00	20000	Low	LTE Band 4 (AWS)	10	23.45	0.14	0.0	LTE SAR #1	QPSK	1	49	1.0 cm	front	0.615
1732.50	20175	Mid	LTE Band 4 (AWS)	10	21.03	0.04	2.0	LTE SAR #1	16 QAM	25	12	1.0 cm	front	0.366
1715.00	20000	Low	LTE Band 4 (AWS)	10	22.42	-0.12	1.0	LTE SAR #1	16 QAM	1	0	1.0 cm	front	0.504
1715.00	20000	Low	LTE Band 4 (AWS)	10	21.99	0.03	1.0	LTE SAR #1	16 QAM	1	49	1.0 cm	front	0.498
1732.50	20175	Mid	LTE Band 4 (AWS)	10	22.03	0.11	1.0	LTE SAR #1	QPSK	25	12	1.0 cm	bottom	0.358
1715.00	20000	Low	LTE Band 4 (AWS)	10	23.64	0.17	0.0	LTE SAR #1	QPSK	1	0	1.0 cm	bottom	0.439
1715.00	20000	Low	LTE Band 4 (AWS)	10	23.45	0.09	0.0	LTE SAR #1	QPSK	1	49	1.0 cm	bottom	0.472
1732.50	20175	Mid	LTE Band 4 (AWS)	10	21.03	-0.03	2.0	LTE SAR #1	16 QAM	25	12	1.0 cm	bottom	0.281
1715.00	20000	Low	LTE Band 4 (AWS)	10	22.42	0.10	1.0	LTE SAR #1	16 QAM	1	0	1.0 cm	bottom	0.333
1715.00	20000	Low	LTE Band 4 (AWS)	10	21.99	0.07	1.0	LTE SAR #1	16 QAM	1	49	1.0 cm	bottom	0.341
1732.50	20175	Mid	LTE Band 4 (AWS)	10	22.03	-0.01	1.0	LTE SAR #1	QPSK	25	12	1.0 cm	right	0.360
1715.00	20000	Low	LTE Band 4 (AWS)	10	23.64	0.21	0.0	LTE SAR #1	QPSK	1	0	1.0 cm	right	0.456
1715.00	20000	Low	LTE Band 4 (AWS)	10	23.45	-0.09	0.0	LTE SAR #1	QPSK	1	49	1.0 cm	right	0.463
1732.50	20175	Mid	LTE Band 4 (AWS)	10	21.03	0.18	2.0	LTE SAR #1	16 QAM	25	12	1.0 cm	right	0.274
1715.00	20000	Low	LTE Band 4 (AWS)	10	22.42	-0.21	1.0	LTE SAR #1	16 QAM	1	0	1.0 cm	right	0.326
1715.00	20000	Low	LTE Band 4 (AWS)	10	21.99	-0.04	1.0	LTE SAR #1	16 QAM	1	49	1.0 cm	right	0.348
ANSI / IEEE C95.1 1992 - SAFETY LIMIT Spatial Peak Uncontrolled Exposure/General Population								Body 1.6 W/kg (mW/g) averaged over 1 gram						



FCC ID: ZNFE970	 PCTEST ENGINEERING LABORATORY, INC.	SAR EVALUATION REPORT	 LG	Reviewed by: Quality Manager
Document S/N: 0Y1207050909-R1.ZNF	Test Dates: 07/05/12 - 08/23/12	DUT Type: Portable Handset		Page 48 of 62

**Table 12-21
LTE Band 2 (PCS) Hotspot SAR Data**

MEASUREMENT RESULTS														
FREQUENCY		Mode	Bandwidth [MHz]	Conducted Power [dBm]	Power Drift [dB]	MPR [dB]	Device Serial Number	Modulation	# of RB	RB Offset	Spacing	Side	SAR (1g) (W/kg)	
MHz	Ch.													
1880.00	18900	Mid	LTE Band 2 (PCS)	10	21.71	0.02	1.0	LTE SAR #3	QPSK	25	12	1.0 cm	back	0.432
1855.00	18650	Low	LTE Band 2 (PCS)	10	23.51	-0.14	0.0	LTE SAR #3	QPSK	1	0	1.0 cm	back	0.623
1855.00	18650	Low	LTE Band 2 (PCS)	10	23.47	-0.02	0.0	LTE SAR #3	QPSK	1	49	1.0 cm	back	0.607
1880.00	18900	Mid	LTE Band 2 (PCS)	10	20.75	0.02	2.0	LTE SAR #3	16 QAM	25	12	1.0 cm	back	0.342
1905.00	19150	High	LTE Band 2 (PCS)	10	22.19	-0.08	1.0	LTE SAR #3	16 QAM	1	0	1.0 cm	back	0.464
1905.00	19150	High	LTE Band 2 (PCS)	10	22.29	0.05	1.0	LTE SAR #3	16 QAM	1	49	1.0 cm	back	0.416
1880.00	18900	Mid	LTE Band 2 (PCS)	10	21.71	0.04	1.0	LTE SAR #3	QPSK	25	12	1.0 cm	front	0.336
1855.00	18650	Low	LTE Band 2 (PCS)	10	23.51	0.12	0.0	LTE SAR #3	QPSK	1	0	1.0 cm	front	0.494
1855.00	18650	Low	LTE Band 2 (PCS)	10	23.47	-0.02	0.0	LTE SAR #3	QPSK	1	49	1.0 cm	front	0.485
1880.00	18900	Mid	LTE Band 2 (PCS)	10	20.75	0.00	2.0	LTE SAR #3	16 QAM	25	12	1.0 cm	front	0.279
1905.00	19150	High	LTE Band 2 (PCS)	10	22.19	0.03	1.0	LTE SAR #3	16 QAM	1	0	1.0 cm	front	0.397
1905.00	19150	High	LTE Band 2 (PCS)	10	22.29	0.06	1.0	LTE SAR #3	16 QAM	1	49	1.0 cm	front	0.324
1880.00	18900	Mid	LTE Band 2 (PCS)	10	21.71	0.34	1.0	LTE SAR #3	QPSK	25	12	1.0 cm	bottom	0.197
1855.00	18650	Low	LTE Band 2 (PCS)	10	23.51	0.11	0.0	LTE SAR #3	QPSK	1	0	1.0 cm	bottom	0.283
1855.00	18650	Low	LTE Band 2 (PCS)	10	23.47	-0.11	0.0	LTE SAR #3	QPSK	1	49	1.0 cm	bottom	0.284
1880.00	18900	Mid	LTE Band 2 (PCS)	10	20.75	0.13	2.0	LTE SAR #3	16 QAM	25	12	1.0 cm	bottom	0.160
1905.00	19150	High	LTE Band 2 (PCS)	10	22.19	-0.03	1.0	LTE SAR #3	16 QAM	1	0	1.0 cm	bottom	0.303
1905.00	19150	High	LTE Band 2 (PCS)	10	22.29	0.06	1.0	LTE SAR #3	16 QAM	1	49	1.0 cm	bottom	0.302
1880.00	18900	Mid	LTE Band 2 (PCS)	10	21.71	0.01	1.0	LTE SAR #3	QPSK	25	12	1.0 cm	left	0.343
1855.00	18650	Low	LTE Band 2 (PCS)	10	23.51	0.00	0.0	LTE SAR #3	QPSK	1	0	1.0 cm	left	0.468
1855.00	18650	Low	LTE Band 2 (PCS)	10	23.47	0.06	0.0	LTE SAR #3	QPSK	1	49	1.0 cm	left	0.486
1880.00	18900	Mid	LTE Band 2 (PCS)	10	20.75	0.01	2.0	LTE SAR #3	16 QAM	25	12	1.0 cm	left	0.283
1905.00	19150	High	LTE Band 2 (PCS)	10	22.19	0.06	1.0	LTE SAR #3	16 QAM	1	0	1.0 cm	left	0.425
1905.00	19150	High	LTE Band 2 (PCS)	10	22.29	0.05	1.0	LTE SAR #3	16 QAM	1	49	1.0 cm	left	0.406
ANSI / IEEE C95.1 1992 - SAFETY LIMIT Spatial Peak Uncontrolled Exposure/General Population								Body 1.6 W/kg (mW/g) averaged over 1 gram						

**Table 12-22
WLAN Hotspot SAR Data**

MEASUREMENT RESULTS										
FREQUENCY		Mode	Service	Conducted Power [dBm]	Power Drift [dB]	Spacing	Device Serial Number	Data Rate (Mbps)	Side	SAR (1g) (W/kg)
MHz	Ch.									
2412	1	IEEE 802.11b	DSSS	16.27	-0.16	1.0 cm	WIFI SAR #1	1	back	0.494
2412	1	IEEE 802.11b	DSSS	16.27	0.04	1.0 cm	WIFI SAR #1	1	front	0.058
2412	1	IEEE 802.11b	DSSS	16.27	0.02	1.0 cm	WIFI SAR #1	1	top	0.052
2412	1	IEEE 802.11b	DSSS	16.27	-0.03	1.0 cm	WIFI SAR #1	1	right	0.203
ANSI / IEEE C95.1 1992 - SAFETY LIMIT Spatial Peak Uncontrolled Exposure/General Population							Body 1.6 W/kg (mW/g) averaged over 1 gram			

FCC ID: ZNFE970	 PCTEST ENGINEERING LABORATORY, INC.	SAR EVALUATION REPORT	 LG	Reviewed by: Quality Manager
Document S/N: OY1207050909-R1.ZNF	Test Dates: 07/05/12 - 08/23/12	DUT Type: Portable Handset		Page 49 of 62

12.4 SAR Test Notes

General Notes:

1. The test data reported are the worst-case SAR value with the position set in a typical configuration. Test procedures used were according to FCC/OET Bulletin 65, Supplement C [June 2001].
2. Batteries are fully charged for all readings. The standard battery was used.
3. Tissue parameters and temperatures are listed on the SAR plots.
4. Liquid tissue depth was at least 15.0 cm. To confirm the proper SAR liquid depth, the z-axis plots from the system verifications were included since the system verifications were performed using the same liquid, probe and DAE as the SAR tests in the same time period.
5. The manufacturer has confirmed that the device(s) tested have the same physical, mechanical and thermal characteristics and are within operational tolerances expected for production units..
6. Per FCC/OET Bulletin 65 Supplement C and Public Notice DA-02-1438, if the SAR measured at the middle channel for each test configuration is at least 3.0 dB lower than the SAR limit, testing at the high and low channels is optional for such test configuration(s).
7. Device was tested using a fixed spacing for body-worn accessory testing. A separation distance of 10 mm was tested because the manufacturer has determined that there will be body-worn accessories available in the marketplace for users to support this separation distance.
8. Per FCC KDB Publication 941225 D06, when the same wireless modes and device transmission configurations are required for body-worn accessories and hotspot mode, it is not necessary to additionally test body-worn accessory SAR for the same device orientation. Therefore, the GPRS, WCDMA, WLAN and LTE hotspot data for the back side configuration additionally shows body-worn compliance at the same distance

GSM Test Notes:



1. Body-Worn accessory testing is typically associated with voice operations. Therefore body-worn SAR testing was additionally performed in GSM voice mode. GPRS Data mode is covered in the Hotspot SAR Testing at the same test distance
2. Justification for reduced test configurations per KDB Publication 941225 D03: The source-based time-averaged output power was evaluated for all multi-slot operations. In addition to the worst-case reported, all source-based time-averaged powers within 10% of the worst-case were additionally included in the evaluation for data modes.
3. Head SAR was additionally tested with GPRS to support SAR compliance for VoIP over GPRS.

WCDMA Notes:

1. WCDMA mode in Body SAR was tested under RMC 12.2 kbps with HSDPA Inactive per KDB Publication 941225 D01. HSPA SAR was not required since the average output power of the HSPA subtests was not more than 0.25 dB higher than the RMC level and SAR was less than 1.2 W/kg.
2. AWS WCDMA SAR was measured with a probe calibrated at 1750 MHz and is valid for measuring SAR from ± 50 MHz. The 1750MHz specific liquid was verified with specific probe calibration factors as required per FCC KDB Publication 450824 D01.

LTE Notes:

1. LTE Considerations: LTE test configurations are determined according to SAR Test Considerations for LTE handsets and Data Modems KDB 941225 D05 Publication and were evaluated independently for each position. General test procedures can be found in Section 9.3.3.
2. MPR is permanently implemented for this device by the manufacturer. The specific manufacturer target MPR is indicated alongside the SAR results. MPR is enabled for this device, according to 3GPP TS36.101 Section 6.2.3 – 6.2.5 under Table 6.2.3-1.

FCC ID: ZNFE970	 PCTEST ENGINEERING LABORATORY, INC.	SAR EVALUATION REPORT	 LG	Reviewed by: Quality Manager
Document S/N: 0Y1207050909-R1.ZNF	Test Dates: 07/05/12 - 08/23/12	DUT Type: Portable Handset		Page 50 of 62



3. Only the primary Tx/Rx LTE antenna applicable for each band was transmitting during testing. The secondary LTE antenna was for receive-only and cannot transmit.
4. A-MPR was disabled for all SAR tests by setting NS=01 on the base station simulator.
5. LTE Band 4 (AWS) SAR was measured with a probe calibrated at 1750 MHz and is valid for measuring SAR from ± 50 MHz. The 1750MHz specific liquid was verified with specific probe calibration factors as required per FCC KDB Publication 450824 D01.

WLAN Notes:

1. Justification for reduced test configurations for WIFI channels per KDB Publication 248227 and April 2010 FCC/TCB Meeting Notes for 2.4 GHz WIFI: Highest average RF output power channel for the lowest data rate was selected for SAR evaluation in 802.11b. Other IEEE 802.11 modes (including 802.11g/n) were not investigated since the average output powers over all channels and data rates were not more than 0.25 dB higher than the tested channel in the lowest data rate of IEEE 802.11b mode.
2. Justification for reduced test configurations for WIFI channels per KDB Publication 248227 and April 2010 FCC/TCB Meeting Notes for 5 GHz WIFI: Highest average RF output power channel for the lowest data rate was selected for SAR evaluation in 802.11a. Other IEEE 802.11 modes (including 802.11n 20 MHz Bandwidth and 802.11n 40 MHz Bandwidth) were not investigated since the average output powers over all channels and data rates were not more than 0.25 dB higher than the tested channel in the lowest data rate of IEEE 802.11a mode.
3. When Hotspot is enabled, all 5 GHz bands are disabled.
4. WLAN transmission was verified using an uncalibrated spectrum analyzer.
5. When the maximum extrapolated peak SAR of the zoom scan for the maximum output channel is <1.6 W/kg and the 1g averaged SAR is <0.8 W/kg, SAR testing on other channels is not required. Otherwise, the other default (or corresponding required) test channels were additionally tested using the lowest data rate.

Hotspot Notes:

1. Top and Right Edges for the GSM/GPRS/EDGE/WCDMA/HSPA and LTE Band 2 and 5 transmitter were not tested since the antenna distance from the edge was greater than 2.5 cm per FCC KDB Publication 941225 D06 guidance (see Section 1.3).
2. Top and Left Edges for the LTE Band 4 and 17 transmitter were not tested since the antenna distance from the edge was greater than 2.5 cm per FCC KDB Publication 941225 D06 guidance (see Section 1.3).
3. Bottom and Left Edges for the WLAN transmitter were not tested since the antenna distance from the edge was greater than 2.5 cm per FCC KDB Publication 941225 D06 (see Section 1.3).
4. During SAR Testing for the Wireless Router conditions per KDB 941225 D06, the actual Portable Hotspot operation (with actual simultaneous transmission of a transmitter with WIFI) was not activated (See Section 7.6.)

FCC ID: ZNFE970	 PCTEST ENGINEERING LABORATORY, INC.	SAR EVALUATION REPORT	 LG	Reviewed by: Quality Manager
Document S/N: 0Y1207050909-R1.ZNF	Test Dates: 07/05/12 - 08/23/12	DUT Type: Portable Handset	Page 51 of 62	

13 FCC MULTI-TX AND ANTENNA SAR CONSIDERATIONS

13.1 Introduction

The following procedures adopted from “FCC SAR Considerations for Cell Phones with Multiple Transmitters” FCC KDB Publication 648474 are applicable to handsets with built-in unlicensed transmitters such as 802.11a/b/g/n and Bluetooth devices which may simultaneously transmit with the licensed transmitter.

13.2 FCC Power Tables & Conditions



	2.45	5.15 - 5.35	5.47 - 5.85	GHz
P_{Ref}	12	6	5	mW

Device output power should be rounded to the nearest mW to compare with values specified in this table.

Figure 13-1
Output Power Thresholds for Unlicensed Transmitters

	Individual Transmitter	Simultaneous Transmission
Licensed Transmitters	<u>Routine evaluation required</u>	SAR not required: <u>Unlicensed only</u>
Unlicensed Transmitters	<p><u>When there is no simultaneous transmission –</u></p> <ul style="list-style-type: none"> output ≤ 60/f: SAR not required output > 60/f: stand-alone SAR required <p><u>When there is simultaneous transmission –</u></p> <p><u>Stand-alone SAR not required when</u></p> <ul style="list-style-type: none"> output $\leq 2 \cdot P_{Ref}$ and antenna is ≥ 5.0 cm from other antennas output $\leq P_{Ref}$ and antenna is ≥ 2.5 cm from other antennas output $\leq P_{Ref}$ and antenna is < 2.5 cm from other antennas, each with either output power $\leq P_{Ref}$ or 1-g SAR < 1.2 W/kg <p><u>Otherwise stand-alone SAR is required</u></p> <p><u>When stand-alone SAR is required</u></p> <ul style="list-style-type: none"> test SAR on highest output channel for each wireless mode and exposure condition if SAR for highest output channel is $> 50\%$ of SAR limit, evaluate all channels according to normal procedures 	<ul style="list-style-type: none"> when stand-alone 1-g SAR is not required and antenna is ≥ 5 cm from other antennas <p><u>Licensed & Unlicensed</u></p> <ul style="list-style-type: none"> when the sum of the 1-g SAR is < 1.6 W/kg for all simultaneous transmitting antennas when SAR to peak location separation ratio of simultaneous transmitting antenna pair is < 0.3 <p>SAR required:</p> <p><u>Licensed & Unlicensed</u></p> <p>antenna pairs with SAR to peak location separation ratio ≥ 0.3; test is only required for the configuration that results in the highest SAR in stand-alone configuration for each wireless mode and exposure condition</p> <p>Note: simultaneous transmission exposure conditions for head and body can be different for different style phones; therefore, different test requirements may apply</p>

Figure 13-2
SAR Evaluation Requirements for Multiple Transmitter Handsets

FCC ID: ZNFE970	 PCTEST ENGINEERING LABORATORY, INC.	SAR EVALUATION REPORT	 LG	Reviewed by: Quality Manager
Document S/N: 0Y1207050909-R1.ZNF	Test Dates: 07/05/12 - 08/23/12	DUT Type: Portable Handset		Page 52 of 62

13.3 Simultaneous Transmission Capabilities

According to Figure 13-1 and Figure 13-2, simultaneous transmission analysis of SAR may be required for this device for the licensed and unlicensed transmitters. Possible simultaneous transmissions for this device were numerically summed using stand-alone SAR data and are shown in the following tables.

Per KDB Publication 648474, standalone Bluetooth SAR tests were not required. Standalone SAR tests for WLAN were required. See Section 1.5(A) for more information.

13.4 Head SAR Simultaneous Transmission Analysis

Table 13-1
Simultaneous Transmission Scenario (Held to Ear)

Simult Tx	Configuration	GSM 850 SAR (W/kg)	2.4 GHz WLAN SAR (W/kg)	Σ SAR (W/kg)	Simult Tx	Configuration	WCDMA 850 SAR (W/kg)	2.4 GHz WLAN SAR (W/kg)	Σ SAR (W/kg)
Head SAR	Right Cheek	0.370	0.139	0.509	Head SAR	Right Cheek	0.311	0.139	0.450
	Right Tilt	0.215	0.071	0.286		Right Tilt	0.183	0.071	0.254
	Left Cheek	0.501	0.330	0.831		Left Cheek	0.419	0.330	0.749
	Left Tilt	0.237	0.073	0.310		Left Tilt	0.208	0.073	0.281
Head SAR	Right Cheek	0.211	0.139	0.350	Head SAR	Right Cheek	0.303	0.139	0.442
	Right Tilt	0.139	0.071	0.210		Right Tilt	0.161	0.071	0.232
	Left Cheek	0.370	0.330	0.700		Left Cheek	0.460	0.330	0.790
	Left Tilt	0.159	0.073	0.232		Left Tilt	0.189	0.073	0.262
Head SAR	Right Cheek	0.225	0.139	0.364	Head SAR	Right Cheek	0.371	0.139	0.510
	Right Tilt	0.129	0.071	0.200		Right Tilt	0.216	0.071	0.287
	Left Cheek	0.175	0.330	0.505		Left Cheek	0.493	0.330	0.823
	Left Tilt	0.112	0.073	0.185		Left Tilt	0.247	0.073	0.320
Head SAR	Right Cheek	0.671	0.139	0.810	Head SAR	Right Cheek	0.285	0.139	0.424
	Right Tilt	0.310	0.071	0.381		Right Tilt	0.184	0.071	0.255
	Left Cheek	0.329	0.330	0.659		Left Cheek	0.642	0.330	0.972
	Left Tilt	0.254	0.073	0.327		Left Tilt	0.208	0.073	0.281
Head SAR	Right Cheek	0.390	0.139	0.529	Head SAR	Right Cheek	0.287	0.139	0.426
	Right Tilt	0.209	0.071	0.280		Right Tilt	0.157	0.071	0.228
	Left Cheek	0.574	0.330	0.904		Left Cheek	0.452	0.330	0.782
	Left Tilt	0.258	0.073	0.331		Left Tilt	0.184	0.073	0.257



FCC ID: ZNFE970	 PCTEST ENGINEERING LABORATORY, INC.	SAR EVALUATION REPORT	 LG	Reviewed by: Quality Manager
Document S/N: 0Y1207050909-R1.ZNF	Test Dates: 07/05/12 - 08/23/12	DUT Type: Portable Handset		Page 53 of 62

Table 13-2
Simultaneous Transmission Scenario (Held to Ear)

Simult Tx	Configuration	GSM 850 SAR (W/kg)	5 GHz WLAN SAR (W/kg)	Σ SAR (W/kg)	Simult Tx	Configuration	WCDMA 850 SAR (W/kg)	5 GHz WLAN SAR (W/kg)	Σ SAR (W/kg)
Head SAR	Right Cheek	0.370	0.055	0.425	Head SAR	Right Cheek	0.311	0.055	0.366
	Right Tilt	0.215	0.048	0.263		Right Tilt	0.183	0.048	0.231
	Left Cheek	0.501	0.195	0.696		Left Cheek	0.419	0.195	0.614
	Left Tilt	0.237	0.042	0.279		Left Tilt	0.208	0.042	0.250
Simult Tx	Configuration	GSM 1900 SAR (W/kg)	5 GHz WLAN SAR (W/kg)	Σ SAR (W/kg)	Simult Tx	Configuration	WCDMA 1900 SAR (W/kg)	5 GHz WLAN SAR (W/kg)	Σ SAR (W/kg)
Head SAR	Right Cheek	0.211	0.055	0.266	Head SAR	Right Cheek	0.303	0.055	0.358
	Right Tilt	0.139	0.048	0.187		Right Tilt	0.161	0.048	0.209
	Left Cheek	0.370	0.195	0.565		Left Cheek	0.460	0.195	0.655
	Left Tilt	0.159	0.042	0.201		Left Tilt	0.189	0.042	0.231



13.5 Body-Worn Simultaneous Transmission Analysis

Table 13-3
Simultaneous Transmission Scenario (Body-Worn at 1.0 cm)

Configuration	Mode	2G/3G/4G SAR (W/kg)	2.4 GHz WLAN SAR (W/kg)	Σ SAR (W/kg)	SPLSR
Back Side	GSM 850	0.580	0.494	1.074	N/A
Back Side	WCDMA 850	0.538	0.494	1.032	N/A
Back Side	GSM 1900	0.420	0.494	0.914	N/A
Back Side	WCDMA 1900	0.575	0.494	1.069	N/A
Back Side	GPRS 850	0.730	0.494	1.224	N/A
Back Side	GPRS 1900	0.522	0.494	1.016	N/A
Back Side	LTE Band 17	0.447	0.494	0.941	N/A
Back Side	LTE Band 5 (Cell)	0.638	0.494	1.132	N/A
Back Side	LTE Band 4 (AWS)	1.220	0.494	See Note	0.25
Back Side	LTE Band 2 (PCS)	0.623	0.494	1.117	N/A

Table 13-4
Simultaneous Transmission Scenario (Body-Worn at 1.0 cm)

Configuration	Mode	2G/3G SAR (W/kg)	5 GHz WLAN SAR (W/kg)	Σ SAR (W/kg)
Back Side	GSM 850	0.580	0.424	1.004
Back Side	WCDMA 850	0.538	0.424	0.962
Back Side	GSM 1900	0.420	0.424	0.844
Back Side	WCDMA 1900	0.575	0.424	0.999

FCC ID: ZNFE970	 PCTEST ENGINEERING LABORATORY, INC.	SAR EVALUATION REPORT	 LG	Reviewed by: Quality Manager
Document S/N: 0Y1207050909-R1.ZNF	Test Dates: 07/05/12 - 08/23/12	DUT Type: Portable Handset		Page 54 of 62



13.6 Hotspot SAR Simultaneous Transmission Analysis

Table 13-5
Simultaneous Transmission Scenario (Hotspot at 1.0 cm)

Simult Tx	Configuration	GPRS 850 SAR (W/kg)	2.4 GHz WLAN SAR (W/kg)	Σ SAR (W/kg)	Simult Tx	Configuration	WCDMA 850 SAR (W/kg)	2.4 GHz WLAN SAR (W/kg)	Σ SAR (W/kg)
Body SAR	Back	0.730	0.494	1.224	Body SAR	Back	0.538	0.494	1.032
	Front	0.736	0.058	0.794		Front	0.451	0.058	0.509
	Top	-	0.052	0.052		Top	-	0.052	0.052
	Bottom	0.186	-	0.186		Bottom	0.186	-	0.186
	Right	-	0.203	0.203		Right	-	0.203	0.203
	Left	0.728	-	0.728		Left	0.630	-	0.630
Simult Tx	Configuration	GPRS 1900 SAR (W/kg)	2.4 GHz WLAN SAR (W/kg)	Σ SAR (W/kg)	Simult Tx	Configuration	WCDMA 1900 SAR (W/kg)	2.4 GHz WLAN SAR (W/kg)	Σ SAR (W/kg)
Body SAR	Back	0.522	0.494	1.016	Body SAR	Back	0.575	0.494	1.069
	Front	0.392	0.058	0.450		Front	0.432	0.058	0.490
	Top	-	0.052	0.052		Top	-	0.052	0.052
	Bottom	0.200	-	0.200		Bottom	0.153	-	0.153
	Right	-	0.203	0.203		Right	-	0.203	0.203
	Left	0.360	-	0.360		Left	0.235	-	0.235
Simult Tx	Configuration	LTE Band 17 SAR (W/kg)	2.4 GHz WLAN SAR (W/kg)	Σ SAR (W/kg)	Simult Tx	Configuration	LTE Band 5 (Cell) SAR (W/kg)	2.4 GHz WLAN SAR (W/kg)	Σ SAR (W/kg)
Body SAR	Back	0.447	0.494	0.941	Body SAR	Back	0.638	0.494	1.132
	Front	0.255	0.058	0.313		Front	0.539	0.058	0.597
	Top	-	0.052	0.052		Top	-	0.052	0.052
	Bottom	0.150	-	0.150		Bottom	0.257	-	0.257
	Right	0.395	0.203	0.598		Right	-	0.203	0.203
	Left	-	-	0.000		Left	0.726	-	0.726
Simult Tx	Configuration	LTE Band 4 (AWS) SAR (W/kg)	2.4 GHz WLAN SAR (W/kg)	Σ SAR (W/kg)	SPLSR				
Body SAR	Back	1.220	0.494	See Note	0.250				
	Front	0.640	0.058	0.698	N/A				
	Top	-	0.052	0.052	N/A				
	Bottom	0.472	-	0.472	N/A				
	Right	0.463	0.203	0.666	N/A				
	Left	-	-	0.000	N/A				
Simult Tx	Configuration	LTE Band 2 (PCS) SAR (W/kg)	2.4 GHz WLAN SAR (W/kg)	Σ SAR (W/kg)					
Body SAR	Back	0.623	0.494	1.117					
	Front	0.494	0.058	0.552					
	Top	-	0.052	0.052					
	Bottom	0.303	-	0.303					
	Right	-	0.203	0.203					
	Left	0.486	-	0.486					

Note:

- Per FCC KDB Publication 941225 D06, the edges with antennas more than 2.5 cm are not required to be evaluated for SAR (“-“). The above tables represent a portable hotspot condition.
- No evaluation was performed to determine the aggregate 1-g SAR in this configuration as the SPLS ratio between the antenna pair was below 0.3 per FCC KDB Publication 646474 Do1. See Section 13.6 for detailed SPLS ratio analysis.

FCC ID: ZNFE970	 PCTEST ENGINEERING LABORATORY, INC.	SAR EVALUATION REPORT	 LG	Reviewed by: Quality Manager
Document S/N: 0Y1207050909-R1.ZNF	Test Dates: 07/05/12 - 08/23/12	DUT Type: Portable Handset		Page 55 of 62

13.7 SPLS Ratio Evaluation Analysis

Per FCC KDB Publication 648474 D01, when the sum of the standalone transmitters is more than 1.6 W/kg, the SAR sum to peak locations can be analyzed to determine SAR distribution overlaps. Based on the 1-g SAR limit and a separation distance of 5 cm, when the SAR peak to location ratio for each pair of antennas is < 0.3, simultaneous SAR evaluation is not required. The distance between the transmitters was calculated using the following formula.

$$\text{Distance}_{\text{Tx1-Tx2}} = \sqrt{(x_1 - x_2)^2 + (y_1 - y_2)^2 + (z_1 - z_2)^2}$$

13.7.1 Body-Worn/Hotspot Back

The sum of the standalone SAR values was above 1.6 W/kg for the Body-Worn/Hotspot configuration with LTE Band 4 (AWS) potentially operating with 2.4 GHz WIFI for the back configuration.

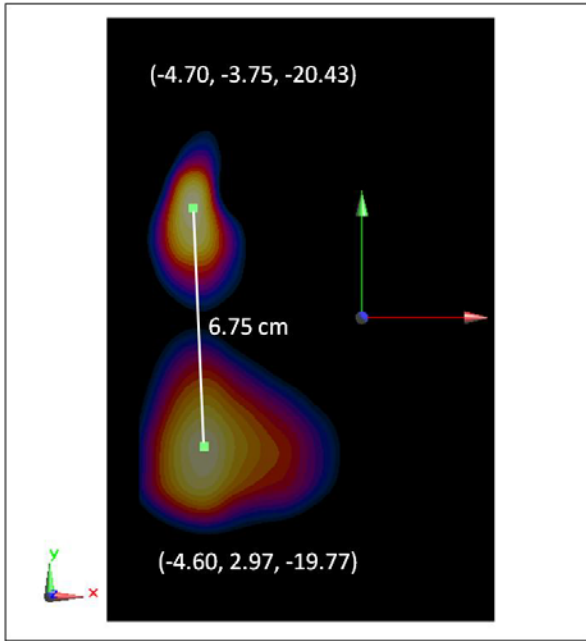

Figure 13-3
Peak SAR Location Plot of LTE Band 4 (AWS) and 2.4 GHz WLAN

Table 13-6
Peak SAR Locations for Body-Worn/Hotspot Back Side LTE band 4 (AWS) and 2.4 GHz WLAN

Mode/Band	x (cm)	y (cm)	z (cm)
LTE Band 4	-4.70	-3.75	-20.43
2.4 GHz WIFI	-4.60	2.97	-19.77

Table 13-7
SAR Sum to Peak Location Separation Ratio Calculation

Antenna Pair		Standalone 1g SAR (W/kg)		Standalone SAR Sum (W/kg)	Peak SAR Separation Distance (cm)	SPLS Ratio
Ant "a"	Ant "b"	a	b	a+b	D _{a-b}	(a+b) / (D _{a-b})
LTE Band 4	2.4 GHz WIFI	1.22	0.494	1.714	6.75	0.25

13.8 Simultaneous Transmission Conclusion



The above numerical summed SAR and SAR Ratio were below the SAR limit. Therefore, the above analysis is sufficient to determine that simultaneous transmission cases will not exceed the SAR limit. No volumetric SAR summation is required per FCC KDB Publication 648474.

FCC ID: ZNFE970	PCTEST ENGINEERING LABORATORY, INC.	SAR EVALUATION REPORT		Reviewed by: Quality Manager
Document S/N: 0Y1207050909-R1.ZNF	Test Dates: 07/05/12 - 08/23/12	DUT Type: Portable Handset		Page 56 of 62

14 EQUIPMENT LIST

Manufacturer	Model	Description	Cal Date	Cal Interval	Cal Due	Serial Number
Agilent	85047A	S-Parameter Test Set	N/A	N/A	N/A	2904A00579
Agilent	85070E	Dielectric Probe Kit	3/8/2012	Annual	3/8/2013	MY44300633
Agilent	8594A	(9kHz-2.9GHz) Spectrum Analyzer	N/A	N/A	N/A	3051A00187
Agilent	8648D	(9kHz-4GHz) Signal Generator	10/10/2011	Annual	10/10/2012	3613A00315
Agilent	8648D	Signal Generator	4/3/2012	Annual	4/3/2013	3629U00687
Agilent	8753E	(30kHz-6GHz) Network Analyzer	4/4/2012	Annual	4/4/2013	JP38020182
Agilent	8753E	(30kHz-6GHz) Network Analyzer	4/3/2012	Annual	4/3/2013	US37390350
Agilent	E5515C	Wireless Communications Test Set	10/14/2011	Annual	10/14/2012	GB41450275
Agilent	E5515C	Wireless Communications Test Set	2/12/2012	Annual	2/12/2013	GB45360985
Agilent	E8257D	(250kHz-20GHz) Signal Generator	4/5/2012	Annual	4/5/2013	MY45470194
Amplifier Research	551G4	5W, 800MHz-4.2GHz	CBT	N/A	CBT	21910
Anritsu	MA2411B	Pulse Sensor	10/13/2011	Annual	10/13/2012	1027293
Anritsu	MA2481A	Power Sensor	2/14/2012	Annual	2/14/2013	5821
Anritsu	MA2481A	Power Sensor	2/14/2012	Annual	2/14/2013	8013
Anritsu	MA2481A	Power Sensor	4/5/2012	Annual	4/5/2013	5605
Anritsu	MA2481A	Power Sensor	2/14/2012	Annual	2/14/2013	2400
Anritsu	ML2438A	Power Meter	2/14/2012	Annual	2/14/2013	1190013
Anritsu	ML2438A	Power Meter	2/14/2012	Annual	2/14/2013	98150041
Anritsu	ML2438A	Power Meter	10/13/2011	Annual	10/13/2012	1070030
Anritsu	ML2495A	Power Meter	10/13/2011	Annual	10/13/2012	1039008
Anritsu	MT8820C	Radio Communication Tester	11/11/2011	Annual	11/11/2012	6209011190
COMTECH	AR85729-5	Solid State Amplifier	CBT	N/A	CBT	M155A00-009
COMTECH	AR85729-5/5759B	Solid State Amplifier	CBT	N/A	CBT	M3W1A00-1002
Control Company	36934-158	Wall-Mounted Thermometer	1/4/2012	Biennial	1/4/2014	122014497
Control Company	36934-158	Wall-Mounted Thermometer	1/4/2012	Biennial	1/4/2014	122014488
Control Company	61220-416	Long-Stem Thermometer	10/12/2011	Biennial	10/12/2013	111860775
Control Company	61220-416	Long-Stem Thermometer	10/12/2011	Biennial	10/12/2013	111860844
Gigatronics	80701A	(0.05-18GHz) Power Sensor	10/12/2011	Annual	10/12/2012	1833460
Gigatronics	8651A	Universal Power Meter	10/12/2011	Annual	10/12/2012	8650319
Intelligent Weigh	PD-3000	Electronic Balance	3/27/2012	Annual	3/27/2013	11081534
MCL	BW-N6W5+	6dB Attenuator	CBT	N/A	CBT	1139
MiniCircuits	SLP-2400+	Low Pass Filter	CBT	N/A	CBT	R8979500903
MiniCircuits	VLF-6000+	Low Pass Filter	CBT	N/A	CBT	N/A
MiniCircuits	VLF-6000+	Low Pass Filter	CBT	N/A	CBT	N/A
Mini-Circuits	BW-N20W5+	DC to 18 GHz Precision Fixed 20 dB Attenuator	CBT	N/A	CBT	N/A
Mini-Circuits	NLP-1200+	Low Pass Filter DC to 1000 MHz	CBT	N/A	CBT	N/A
Mini-Circuits	NLP-2950+	Low Pass Filter DC to 2700 MHz	CBT	N/A	CBT	N/A
Narda	4014C-6	4 - 8 GHz SMA 6 dB Directional Coupler	CBT	N/A	CBT	N/A
Narda	4772-3	Attenuator (3dB)	CBT	N/A	CBT	9406
Narda	BW-53W2	Attenuator (3dB)	CBT	N/A	CBT	120
Rohde & Schwarz	CMU200	Base Station Simulator	5/22/2012	Annual	5/22/2013	109892
Rohde & Schwarz	CMW500	LTE Radio Communication Tester	11/30/2011	Annual	11/30/2012	101699
Rohde & Schwarz	CMW500	LTE Radio Communication Tester	3/5/2012	Annual	3/5/2013	102060
Rohde & Schwarz	NRVD	Dual Channel Power Meter	4/8/2011	Biennial	4/8/2013	101695
Rohde & Schwarz	SMIQ03B	Signal Generator	4/5/2012	Annual	4/5/2013	DE27259
Seekonk	NC-100	Torque Wrench (8" lb)	11/29/2011	Triennial	11/29/2014	21053
Seekonk	NC-100	Torque Wrench (8" lb)	3/5/2012	Triennial	3/5/2015	N/A
Seekonk	NC-100	Torque Wrench (8" lb)	3/5/2012	Triennial	3/5/2015	N/A
SPEAG	D1765V2	1765 MHz SAR Dipole	5/18/2012	Annual	5/18/2013	1008
SPEAG	D1900V2	1900 MHz SAR Dipole	7/22/2011	Annual	7/22/2012	5d080
SPEAG	D1900V2	1900 MHz SAR Dipole	4/26/2012	Annual	4/26/2013	5d141
SPEAG	D1900V2	1900 MHz SAR Dipole	2/22/2012	Annual	2/22/2013	5d149
SPEAG	D2450V2	2450 MHz SAR Dipole	1/24/2012	Annual	1/24/2013	797
SPEAG	D56HzV2	5 GHz SAR Dipole	1/19/2012	Annual	1/19/2013	1057
SPEAG	D750V3	750 MHz Dipole	1/27/2012	Annual	1/27/2013	1003
SPEAG	D750V3	750 MHz Dipole	2/9/2012	Annual	2/9/2013	1054
SPEAG	D835V2	835 MHz SAR Dipole	4/20/2012	Annual	4/20/2013	4d119
SPEAG	D835V2	835 MHz SAR Dipole	2/17/2012	Annual	2/17/2013	4d133
SPEAG	DAE4	Dasy Data Acquisition Electronics	4/19/2012	Annual	4/19/2013	665
SPEAG	DAE4	Dasy Data Acquisition Electronics	2/20/2012	Annual	2/20/2013	649
SPEAG	DAE4	Dasy Data Acquisition Electronics	1/18/2012	Annual	1/18/2013	1272
SPEAG	DAE4	Dasy Data Acquisition Electronics	2/15/2012	Annual	2/15/2013	1323
SPEAG	ES3DV2	SAR Probe	8/25/2011	Annual	8/25/2012	3022
SPEAG	ES3DV3	SAR Probe	3/16/2012	Annual	3/16/2013	3209
SPEAG	ES3DV3	SAR Probe	2/21/2012	Annual	2/21/2013	3258
SPEAG	ES3DV3	SAR Probe	2/7/2012	Annual	2/7/2013	3287
SPEAG	EX3DV4	SAR Probe	1/27/2012	Annual	1/27/2013	3589
Tektronix	RSA-6114A	Real Time Spectrum Analyzer	4/5/2012	Annual	4/5/2013	8010177
VWR	36934-158	Wall-Mounted Thermometer	9/30/2011	Biennial	9/30/2013	111859323
VWR	36934-158	Wall-Mounted Thermometer	9/30/2011	Biennial	9/30/2013	111859332
VWR	62344-925	Mini-Thermometer	10/24/2011	Biennial	10/24/2013	111886441

Note: CBT (Calibrated Before Testing). Prior to testing, the measurement paths containing a cable, attenuator, coupler, amplifier, or filter were connected to a calibrated source (i.e. a signal generator) to determine the losses of the measurement path. The power meter offset was then adjusted to compensate for the measurement system losses. This level offset is stored within the power meter before measurements are made. This calibration verification procedure applies to the system verification and output power measurements. The calibrated reading is then taken directly from the power meter after compensation of the losses for all final power measurements.



FCC ID: ZNFE970		SAR EVALUATION REPORT		Reviewed by: Quality Manager
Document S/N: 0Y1207050909-R1.ZNF	Test Dates: 07/05/12 - 08/23/12	DUT Type: Portable Handset		Page 57 of 62

15 MEASUREMENT UNCERTAINTIES

Applicable for frequencies less than 3000 MHz.

a	b	c	d	e= f(d,k)	f	g	h = c x f/e	i = c x g/e	k	
Uncertainty Component	IEEE 1528 Sec.	Tol. (± %)	Prob. Dist.	Div.	c _i 1gm	c _i 10 gms	1gm u _i (± %)	10gms u _i (± %)	v _i	
Measurement System										
Probe Calibration	E.2.1	6.0	N	1	1.0	1.0	6.0	6.0	∞	
Axial Isotropy	E.2.2	0.25	N	1	0.7	0.7	0.2	0.2	∞	
Hemishperical Isotropy	E.2.2	1.3	N	1	1.0	1.0	1.3	1.3	∞	
Boundary Effect	E.2.3	0.4	N	1	1.0	1.0	0.4	0.4	∞	
Linearity	E.2.4	0.3	N	1	1.0	1.0	0.3	0.3	∞	
System Detection Limits	E.2.5	5.1	N	1	1.0	1.0	5.1	5.1	∞	
Readout Electronics	E.2.6	1.0	N	1	1.0	1.0	1.0	1.0	∞	
Response Time	E.2.7	0.8	R	1.73	1.0	1.0	0.5	0.5	∞	
Integration Time	E.2.8	2.6	R	1.73	1.0	1.0	1.5	1.5	∞	
RF Ambient Conditions	E.6.1	3.0	R	1.73	1.0	1.0	1.7	1.7	∞	
Probe Positioner Mechanical Tolerance	E.6.2	0.4	R	1.73	1.0	1.0	0.2	0.2	∞	
Probe Positioning w/ respect to Phantom	E.6.3	2.9	R	1.73	1.0	1.0	1.7	1.7	∞	
Extrapolation, Interpolation & Integration algorithms for Max. SAR Evaluation	E.5	1.0	R	1.73	1.0	1.0	0.6	0.6	∞	
Test Sample Related										
Test Sample Positioning	E.4.2	6.0	N	1	1.0	1.0	6.0	6.0	287	
Device Holder Uncertainty	E.4.1	3.32	R	1.73	1.0	1.0	1.9	1.9	∞	
Output Power Variation - SAR drift measurement	6.6.2	5.0	R	1.73	1.0	1.0	2.9	2.9	∞	
Phantom & Tissue Parameters										
Phantom Uncertainty (Shape & Thickness tolerances)	E.3.1	4.0	R	1.73	1.0	1.0	2.3	2.3	∞	
Liquid Conductivity - deviation from target values	E.3.2	5.0	R	1.73	0.64	0.43	1.8	1.2	∞	
Liquid Conductivity - measurement uncertainty	E.3.3	3.8	N	1	0.64	0.43	2.4	1.6	6	
Liquid Permittivity - deviation from target values	E.3.2	5.0	R	1.73	0.60	0.49	1.7	1.4	∞	
Liquid Permittivity - measurement uncertainty	E.3.3	4.5	N	1	0.60	0.49	2.7	2.2	6	
Combined Standard Uncertainty (k=1)							RSS	12.1	11.7	299
Expanded Uncertainty (95% CONFIDENCE LEVEL)							k=2	24.2	23.5	



The above measurement uncertainties are according to IEEE Std. 1528-2003

FCC ID: ZNFE970	 PCTEST ENGINEERING LABORATORY, INC.	SAR EVALUATION REPORT	 LG	Reviewed by: Quality Manager
Document S/N: 0Y1207050909-R1.ZNF	Test Dates: 07/05/12 - 08/23/12	DUT Type: Portable Handset		Page 58 of 62

Applicable for frequencies up to 6 GHz.

a	b	c	d	e= f(d,k)	f	g	h = c x f/e	i = c x g/e	k	
Uncertainty Component	IEEE 1528 Sec.	Tol. (± %)	Prob. Dist.	Div.	c _i 1gm	c _i 10 gms	1gm u _i (± %)	10gms u _i (± %)	v _i	
Measurement System										
Probe Calibration	E.2.1	6.55	N	1	1.0	1.0	6.6	6.6	∞	
Axial Isotropy	E.2.2	0.25	N	1	0.7	0.7	0.2	0.2	∞	
Hemishperical Isotropy	E.2.2	1.3	N	1	1.0	1.0	1.3	1.3	∞	
Boundary Effect	E.2.3	0.4	N	1	1.0	1.0	0.4	0.4	∞	
Linearity	E.2.4	0.3	N	1	1.0	1.0	0.3	0.3	∞	
System Detection Limits	E.2.5	5.1	N	1	1.0	1.0	5.1	5.1	∞	
Readout Electronics	E.2.6	1.0	N	1	1.0	1.0	1.0	1.0	∞	
Response Time	E.2.7	0.8	R	1.73	1.0	1.0	0.5	0.5	∞	
Integration Time	E.2.8	2.6	R	1.73	1.0	1.0	1.5	1.5	∞	
RF Ambient Conditions	E.6.1	3.0	R	1.73	1.0	1.0	1.7	1.7	∞	
Probe Positioner Mechanical Tolerance	E.6.2	0.4	R	1.73	1.0	1.0	0.2	0.2	∞	
Probe Positioning w/ respect to Phantom	E.6.3	2.9	R	1.73	1.0	1.0	1.7	1.7	∞	
Extrapolation, Interpolation & Integration algorithms for Max. SAR Evaluation	E.5	1.0	R	1.73	1.0	1.0	0.6	0.6	∞	
Test Sample Related										
Test Sample Positioning	E.4.2	6.0	N	1	1.0	1.0	6.0	6.0	287	
Device Holder Uncertainty	E.4.1	3.32	R	1.73	1.0	1.0	1.9	1.9	∞	
Output Power Variation - SAR drift measurement	6.6.2	5.0	R	1.73	1.0	1.0	2.9	2.9	∞	
Phantom & Tissue Parameters										
Phantom Uncertainty (Shape & Thickness tolerances)	E.3.1	4.0	R	1.73	1.0	1.0	2.3	2.3	∞	
Liquid Conductivity - deviation from target values	E.3.2	5.0	R	1.73	0.64	0.43	1.8	1.2	∞	
Liquid Conductivity - measurement uncertainty	E.3.3	3.8	N	1	0.64	0.43	2.4	1.6	6	
Liquid Permittivity - deviation from target values	E.3.2	5.0	R	1.73	0.60	0.49	1.7	1.4	∞	
Liquid Permittivity - measurement uncertainty	E.3.3	4.5	N	1	0.60	0.49	2.7	2.2	6	
Combined Standard Uncertainty (k=1)							RSS	12.4	12.0	299
Expanded Uncertainty (95% CONFIDENCE LEVEL)							k=2	24.7	24.0	

The above measurement uncertainties are according to IEEE Std. 1528-2003



FCC ID: ZNFE970	 PCTEST ENGINEERING LABORATORY, INC.	SAR EVALUATION REPORT		Reviewed by: Quality Manager
Document S/N: 0Y1207050909-R1.ZNF	Test Dates: 07/05/12 - 08/23/12	DUT Type: Portable Handset		Page 59 of 62

16 CONCLUSION

16.1 Measurement Conclusion



The SAR evaluation indicates that the EUT complies with the RF radiation exposure limits of the FCC and Industry Canada, with respect to all parameters subject to this test. These measurements were taken to simulate the RF effects of RF exposure under worst-case conditions. Precise laboratory measures were taken to assure repeatability of the tests. The results and statements relate only to the item(s) tested.

Please note that the absorption and distribution of electromagnetic energy in the body are very complex phenomena that depend on the mass, shape, and size of the body, the orientation of the body with respect to the field vectors, and the electrical properties of both the body and the environment. Other variables that may play a substantial role in possible biological effects are those that characterize the environment (e.g. ambient temperature, air velocity, relative humidity, and body insulation) and those that characterize the individual (e.g. age, gender, activity level, debilitation, or disease). Because various factors may interact with one another to vary the specific biological outcome of an exposure to electromagnetic fields, any protection guide should consider maximal amplification of biological effects as a result of field-body interactions, environmental conditions, and physiological variables. [3]



FCC ID: ZNFE970	 PCTEST ENGINEERING LABORATORY, INC.	SAR EVALUATION REPORT	 LG	Reviewed by: Quality Manager
Document S/N: 0Y1207050909-R1.ZNF	Test Dates: 07/05/12 - 08/23/12	DUT Type: Portable Handset		Page 60 of 62

17 REFERENCES

- [1] Federal Communications Commission, ET Docket 93-62, Guidelines for Evaluating the Environmental Effects of Radiofrequency Radiation, Aug. 1996.
- [2] ANSI/IEEE C95.1-2005, American National Standard safety levels with respect to human exposure to radio frequency electromagnetic fields, 3kHz to 300GHz, New York: IEEE, 2006.
- [3] ANSI/IEEE C95.1-1992, American National Standard safety levels with respect to human exposure to radio frequency electromagnetic fields, 3kHz to 300GHz, New York: IEEE, Sept. 1992.
- [4] ANSI/IEEE C95.3-2002, IEEE Recommended Practice for the Measurement of Potentially Hazardous Electromagnetic Fields - RF and Microwave, New York: IEEE, December 2002.
- [5] Federal Communications Commission, OET Bulletin 65 (Edition 97-01), Supplement C (Edition 01-01), Evaluating Compliance with FCC Guidelines for Human Exposure to Radiofrequency Electromagnetic Fields, June 2001.
- [6] IEEE Standards Coordinating Committee 34 – IEEE Std. 1528-2003, Recommended Practice for Determining the Peak Spatial-Average Specific Absorption Rate (SAR) in the Human Body Due to Wireless Communications Devices.
- [7] NCRP, National Council on Radiation Protection and Measurements, Biological Effects and Exposure Criteria for RadioFrequency Electromagnetic Fields, NCRP Report No. 86, 1986. Reprinted Feb. 1995.
- [8] T. Schmid, O. Egger, N. Kuster, Automated E-field scanning system for dosimetric assessments, IEEE Transaction on Microwave Theory and Techniques, vol. 44, Jan. 1996, pp. 105-113.
- [9] K. Pokovic, T. Schmid, N. Kuster, Robust setup for precise calibration of E-field probes in tissue simulating liquids at mobile communications frequencies, ICECOM97, Oct. 1997, pp. 120-124.
- [10] K. Pokovic, T. Schmid, and N. Kuster, E-field Probe with improved isotropy in brain simulating liquids, Proceedings of the ELMAR, Zadar, Croatia, June 23-25, 1996, pp. 172-175.
- [11] Schmid & Partner Engineering AG, Application Note: Data Storage and Evaluation, June 1998, p2.
- [12] V. Hombach, K. Meier, M. Burkhardt, E. Kuhn, N. Kuster, The Dependence of EM Energy Absorption upon Human Head Modeling at 900 MHz, IEEE Transaction on Microwave Theory and Techniques, vol. 44 no. 10, Oct. 1996, pp. 1865-1873.
- [13] N. Kuster and Q. Balzano, Energy absorption mechanism by biological bodies in the near field of dipole antennas above 300MHz, IEEE Transaction on Vehicular Technology, vol. 41, no. 1, Feb. 1992, pp. 17-23.
- [14] G. Hartsgrove, A. Kraszewski, A. Surowiec, Simulated Biological Materials for Electromagnetic Radiation Absorption Studies, University of Ottawa, Bioelectromagnetics, Canada: 1987, pp. 29-36.
- [15] Q. Balzano, O. Garay, T. Manning Jr., Electromagnetic Energy Exposure of Simulated Users of Portable Cellular Telephones, IEEE Transactions on Vehicular Technology, vol. 44, no.3, Aug. 1995.
- [16] W. Gander, Computermathematik, Birkhaeuser, Basel, 1992.
- [17] W.H. Press, S.A. Teukolsky, W.T. Vetterling, and B.P. Flannery, Numerical Recipes in C, The Art of Scientific Computing, Second edition, Cambridge University Press, 1992.

FCC ID: ZNFE970	 PCTEST ENGINEERING LABORATORY, INC.	SAR EVALUATION REPORT	 LG	Reviewed by: Quality Manager
Document S/N: 0Y1207050909-R1.ZNF	Test Dates: 07/05/12 - 08/23/12	DUT Type: Portable Handset		Page 61 of 62

- [18] Federal Communications Commission, OET Bulletin 65, Evaluating Compliance with FCC Guidelines for Human Exposure to Radiofrequency Electromagnetic Fields. Supplement C, Dec. 1997.
- [19] N. Kuster, R. Kastle, T. Schmid, Dosimetric evaluation of mobile communications equipment with known precision, IEEE Transaction on Communications, vol. E80-B, no. 5, May 1997, pp. 645-652.
- [20] CENELEC CLC/SC111B, European Prestandard (prENV 50166-2), Human Exposure to Electromagnetic Fields High-frequency: 10kHz-300GHz, Jan. 1995.
- [21] Prof. Dr. Niels Kuster, ETH, Eidgenössische Technische Hochschule Zürich, Dosimetric Evaluation of the Cellular Phone.
- [22] IEC 62209-1, Human exposure to radio frequency fields from hand-held and body-mounted wireless communication devices - Human models, instrumentation, and procedures - Part 1: Procedure to determine the specific absorption rate (SAR) for hand-held devices used in close proximity to the ear (frequency range of 300 MHz to 3 GHz), Feb. 2005.
- [23] Industry Canada RSS-102 Radio Frequency Exposure Compliance of Radiocommunication Apparatus (All Frequency Bands) Issue 4, March 2010.
- [24] Health Canada Safety Code 6 Limits of Human Exposure to Radio Frequency Electromagnetic Fields in the Frequency Range from 3 kHz – 300 GHz, 2009
- [25] FCC Public Notice DA-02-1438. Office of Engineering and Technology Announces a Transition Period for the Phantom Requirements of Supplement C to OET Bulletin 65, June 19, 2002
- [26] FCC SAR Measurement Procedures for 3G Devices KDB Publication 941225
- [27] SAR Measurement procedures for IEEE 802.11a/b/g KDB Publication 248227
- [28] FCC SAR Considerations for Handsets with Multiple Transmitters and Antennas, KDB Publication 648474
- [29] FCC Application Note for SAR Probe Calibration and System Verification Consideration for Measurements at 150 MHz – 3 GHz, KDB Publication 450824
- [30] FCC SAR Evaluation Considerations for Laptop Computers with Antennas Built-in on Display Screens, KDB Publication 616217
- [31] FCC SAR Measurement Requirements for 3 – 6 GHz, KDB Publication 865664
- [32] FCC Mobile Portable RF Exposure Procedure, KDB Publication 447498
- [33] FCC SAR Procedures for Dongle Transmitters, KDB Publication 447498
- [34] Anexo à Resolução No. 533, de 10 de Setembro de 2009.
- [35] FCC SAR Test Considerations for LTE Handsets and Data Modems, KDB Publication 941225.
- [36] IEC 62209-2, Human exposure to radio frequency fields from hand-held and body-mounted wireless communication devices - Human models, instrumentation, and procedures - Part 2: Procedure to determine the specific absorption rate (SAR) for wireless communication devices used in close proximity to the human body (frequency range of 30 MHz to 6 GHz), Mar. 2010.
- [37] FCC Hot Spot SAR v01, KDB Publication 941225 D06.

FCC ID: ZNFE970		SAR EVALUATION REPORT		Reviewed by: Quality Manager
Document S/N: 0Y1207050909-R1.ZNF	Test Dates: 07/05/12 - 08/23/12	DUT Type: Portable Handset	Page 62 of 62	

APPENDIX A: SAR TEST DATA

PCTEST ENGINEERING LABORATORY, INC.

DUT: ZNFE970; Type: Portable Handset; Serial: LTE SAR#1

Communication System: LTE BAND 17; Frequency: 710 MHz; Duty Cycle: 1:1

Medium: 695 Head Medium parameters used:

$f = 710 \text{ MHz}$; $\sigma = 0.874 \text{ mho/m}$; $\epsilon_r = 43.37$; $\rho = 1000 \text{ kg/m}^3$

Phantom section: Right Section

Test Date: 07-10-2012; Ambient Temp: 23.2°C; Tissue Temp: 22.5°C

Probe: ES3DV3 - SN3287; ConvF(6.25, 6.25, 6.25); Calibrated: 2/7/2012;

Sensor-Surface: 4mm (Mechanical Surface Detection)

Electronics: DAE4 Sn649; Calibrated: 2/20/2012

Phantom: SAM v5.0 Left; Type: QD000P40CD; Serial: TP: 1687

Measurement SW: DASY52, Version 52.8 (1); SEMCAD X Version 14.6.5 (6469)

Mode: LTE Band 17, Right Head, Cheek, Mid. Ch

10 MHz Bandwidth, QPSK, 1 RB, RB Offset 49

Area Scan (7x14x1): Measurement grid: dx=15mm, dy=15mm

Zoom Scan (5x5x7)/Cube 0: Measurement grid: dx=8mm, dy=8mm, dz=5mm

Reference Value = 17.343 V/m; Power Drift = 0.17 dB

Peak SAR (extrapolated) = 0.287 mW/g

SAR(1 g) = 0.225 mW/g; SAR(10 g) = 0.171 mW/g

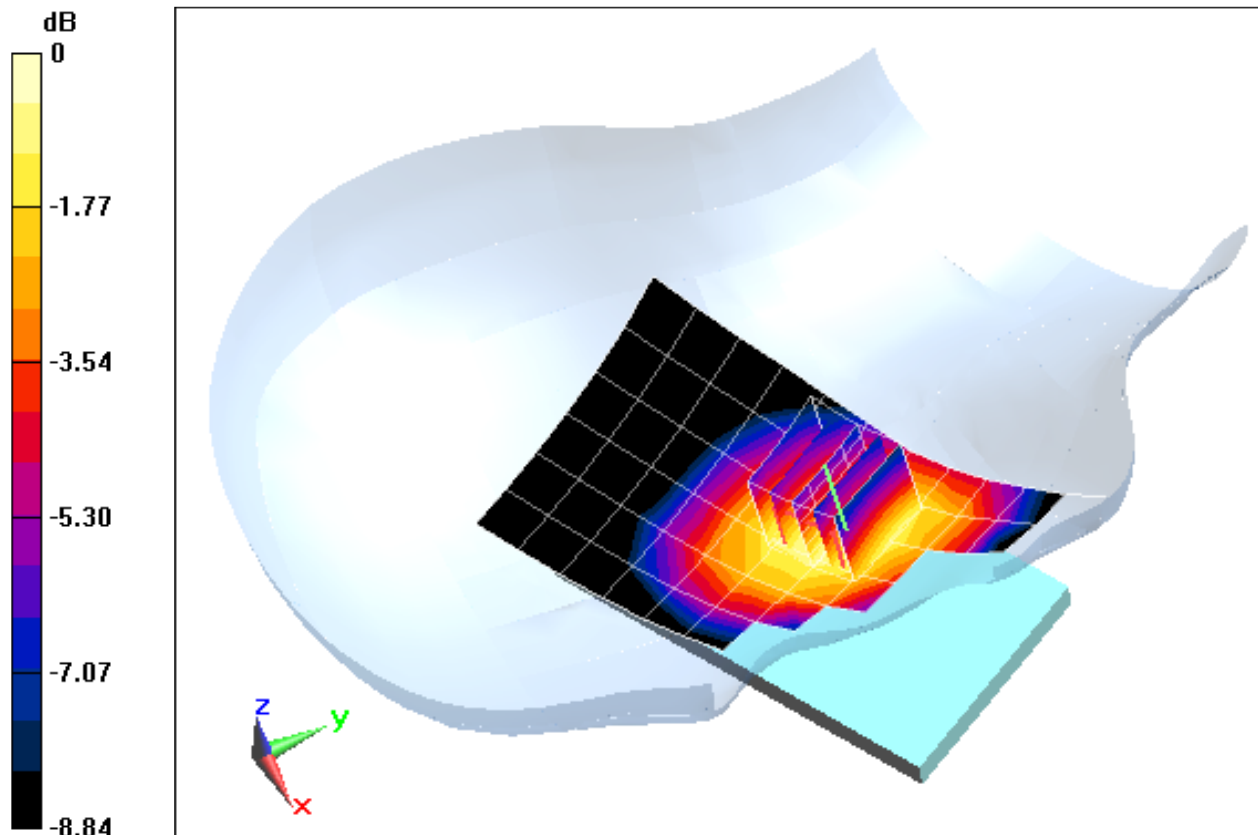

0 dB = 0.238 mW/g = -12.47 dB mW/g

PCTEST ENGINEERING LABORATORY, INC.

DUT: ZNFE970; Type: Portable Handset; Serial: LTE SAR#1

Communication System: LTE BAND 17; Frequency: 710 MHz; Duty Cycle: 1:1

Medium: 695 Head Medium parameters used:

$f = 710 \text{ MHz}$; $\sigma = 0.874 \text{ mho/m}$; $\epsilon_r = 43.37$; $\rho = 1000 \text{ kg/m}^3$

Phantom section: Right Section

Test Date: 07-10-2012; Ambient Temp: 23.2°C; Tissue Temp: 22.5°C

Probe: ES3DV3 - SN3287; ConvF(6.25, 6.25, 6.25); Calibrated: 2/7/2012;

Sensor-Surface: 4mm (Mechanical Surface Detection)

Electronics: DAE4 Sn649; Calibrated: 2/20/2012

Phantom: SAM v5.0 Left; Type: QD000P40CD; Serial: TP: 1687

Measurement SW: DASY52, Version 52.8 (1); SEMCAD X Version 14.6.5 (6469)

**Mode: LTE Band 17, Right Head, Tilt, Mid.ch, QPSK
10 MHz Bandwidth, 1 RB, RB Offset 49**

Area Scan (9x14x1): Measurement grid: dx=15mm, dy=15mm

Zoom Scan (5x5x7)/Cube 0: Measurement grid: dx=8mm, dy=8mm, dz=5mm

Reference Value = 12.878 V/m; Power Drift = 0.21 dB

Peak SAR (extrapolated) = 0.150 mW/g

SAR(1 g) = 0.129 mW/g; SAR(10 g) = 0.103 mW/g

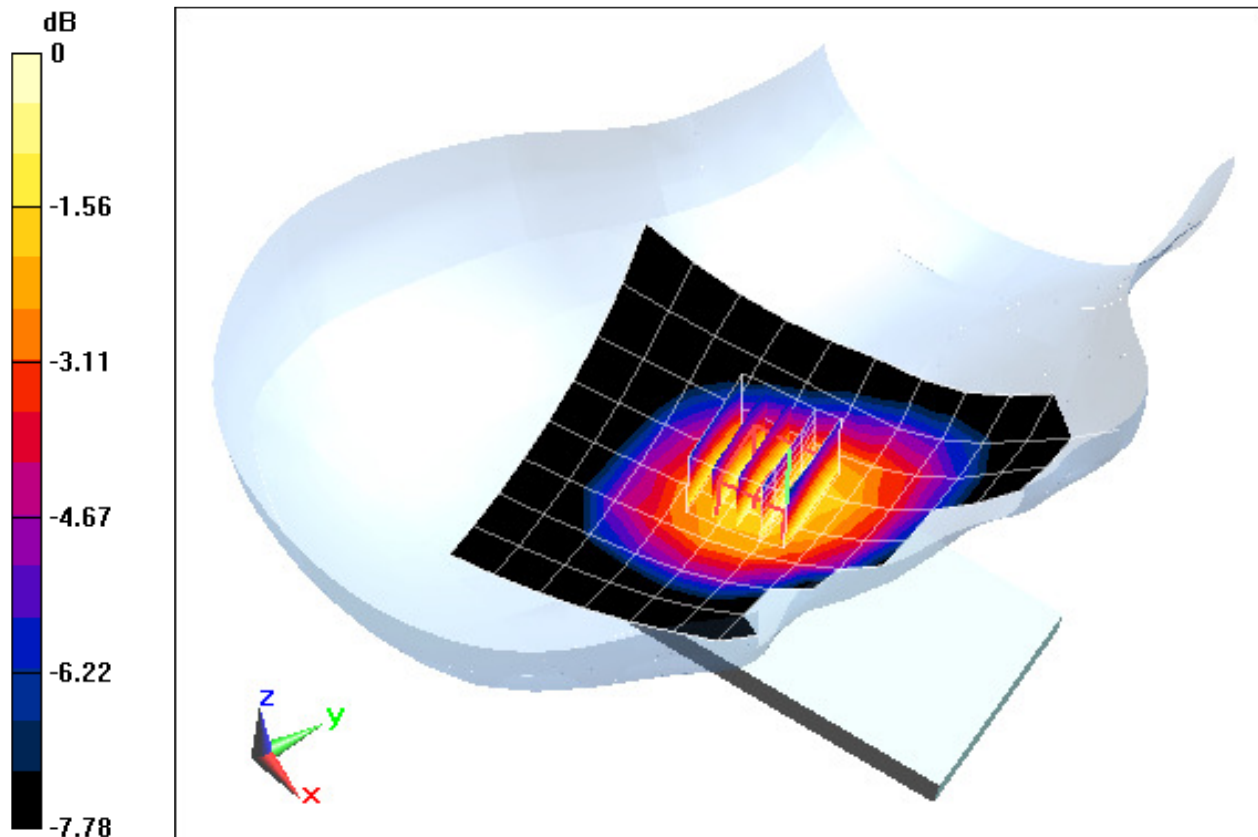

0 dB = 0.135 mW/g = -17.39 dB mW/g

PCTEST ENGINEERING LABORATORY, INC.

DUT: ZNFE970; Type: Portable Handset; Serial: LTE SAR#1

Communication System: LTE BAND 17; Frequency: 710 MHz; Duty Cycle: 1:1
Medium: 695 Head Medium parameters used:

$f = 710 \text{ MHz}; \sigma = 0.874 \text{ mho/m}; \epsilon_r = 43.37; \rho = 1000 \text{ kg/m}^3$

Phantom section: Left Section

Test Date: 07-10-2012; Ambient Temp: 23.2°C; Tissue Temp: 22.5°C

Probe: ES3DV3 - SN3287; ConvF(6.25, 6.25, 6.25); Calibrated: 2/7/2012;

Sensor-Surface: 4mm (Mechanical Surface Detection)

Electronics: DAE4 Sn649; Calibrated: 2/20/2012

Phantom: SAM v5.0 Left; Type: QD000P40CD; Serial: TP: 1687

Measurement SW: DASY52, Version 52.8 (1); SEMCAD X Version 14.6.5 (6469)

Mode: LTE Band 17, Left Head, Cheek, Mid. Ch
10 MHz Bandwidth, QPSK, 1 RB, RB Offset 49

Area Scan (9x14x1): Measurement grid: dx=15mm, dy=15mm

Zoom Scan (5x5x7)/Cube 0: Measurement grid: dx=8mm, dy=8mm, dz=5mm

Reference Value = 15.033 V/m; Power Drift = 0.02 dB

Peak SAR (extrapolated) = 0.203 mW/g

SAR(1 g) = 0.175 mW/g; SAR(10 g) = 0.138 mW/g

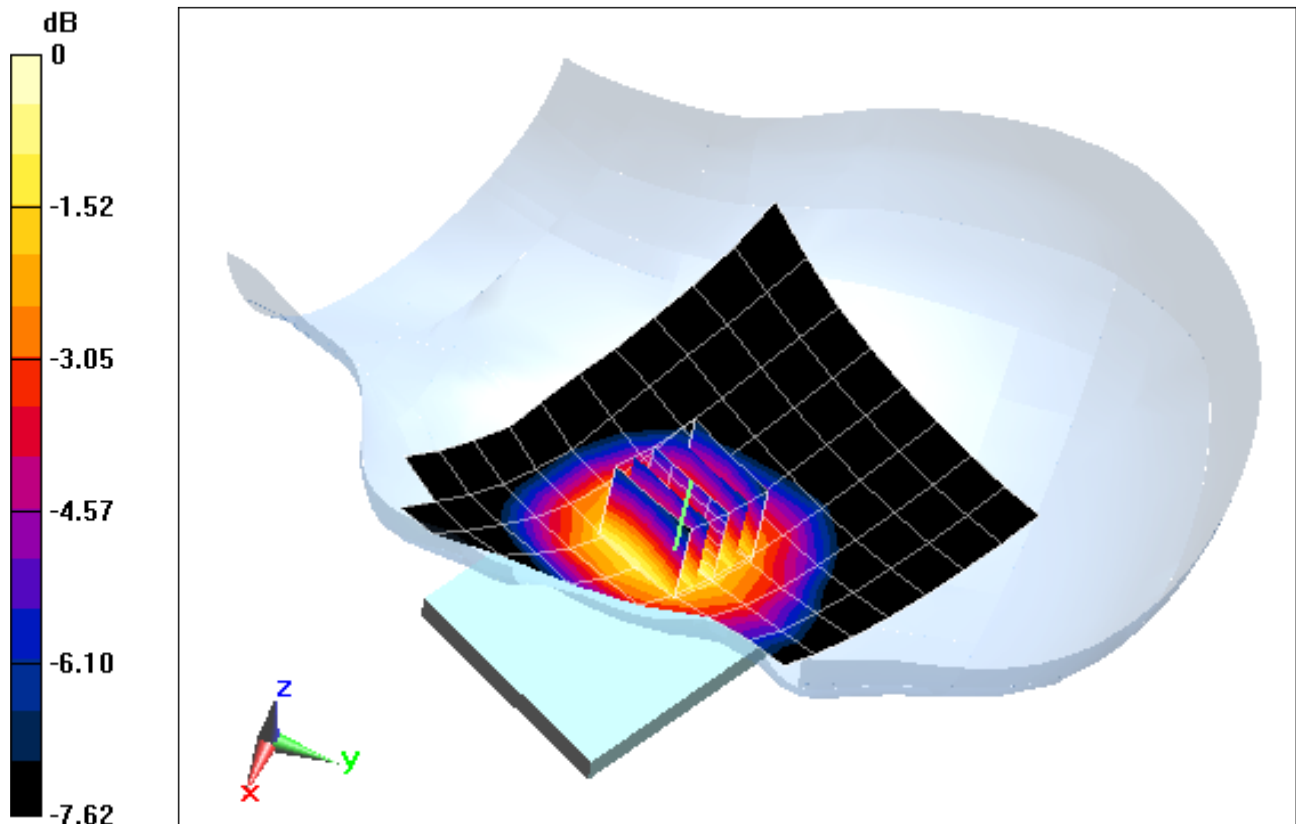

0 dB = 0.182 mW/g = -14.80 dB mW/g

PCTEST ENGINEERING LABORATORY, INC.

DUT: ZNFE970; Type: Portable Handset; Serial: LTE SAR#1

Communication System: LTE BAND 17; Frequency: 710 MHz; Duty Cycle: 1:1
Medium: 695 Head Medium parameters used:

$f = 710 \text{ MHz}$; $\sigma = 0.874 \text{ mho/m}$; $\epsilon_r = 43.37$; $\rho = 1000 \text{ kg/m}^3$

Phantom section: Left Section

Test Date: 07-10-2012; Ambient Temp: 23.2°C; Tissue Temp: 22.5°C

Probe: ES3DV3 - SN3287; ConvF(6.25, 6.25, 6.25); Calibrated: 2/7/2012;

Sensor-Surface: 4mm (Mechanical Surface Detection)

Electronics: DAE4 Sn649; Calibrated: 2/20/2012

Phantom: SAM v5.0 Left; Type: QD000P40CD; Serial: TP: 1687

Measurement SW: DASY52, Version 52.8 (1); SEMCAD X Version 14.6.5 (6469)

Mode: LTE Band 17, Left Head, Tilt, Mid.ch
10 MHz Bandwidth, QPSK, 1 RB, RB Offset 49

Area Scan (9x14x1): Measurement grid: dx=15mm, dy=15mm

Zoom Scan (5x5x7)/Cube 0: Measurement grid: dx=8mm, dy=8mm, dz=5mm

Reference Value = 12.229 V/m; Power Drift = 0.11 dB

Peak SAR (extrapolated) = 0.132 mW/g

SAR(1 g) = 0.112 mW/g; SAR(10 g) = 0.089 mW/g

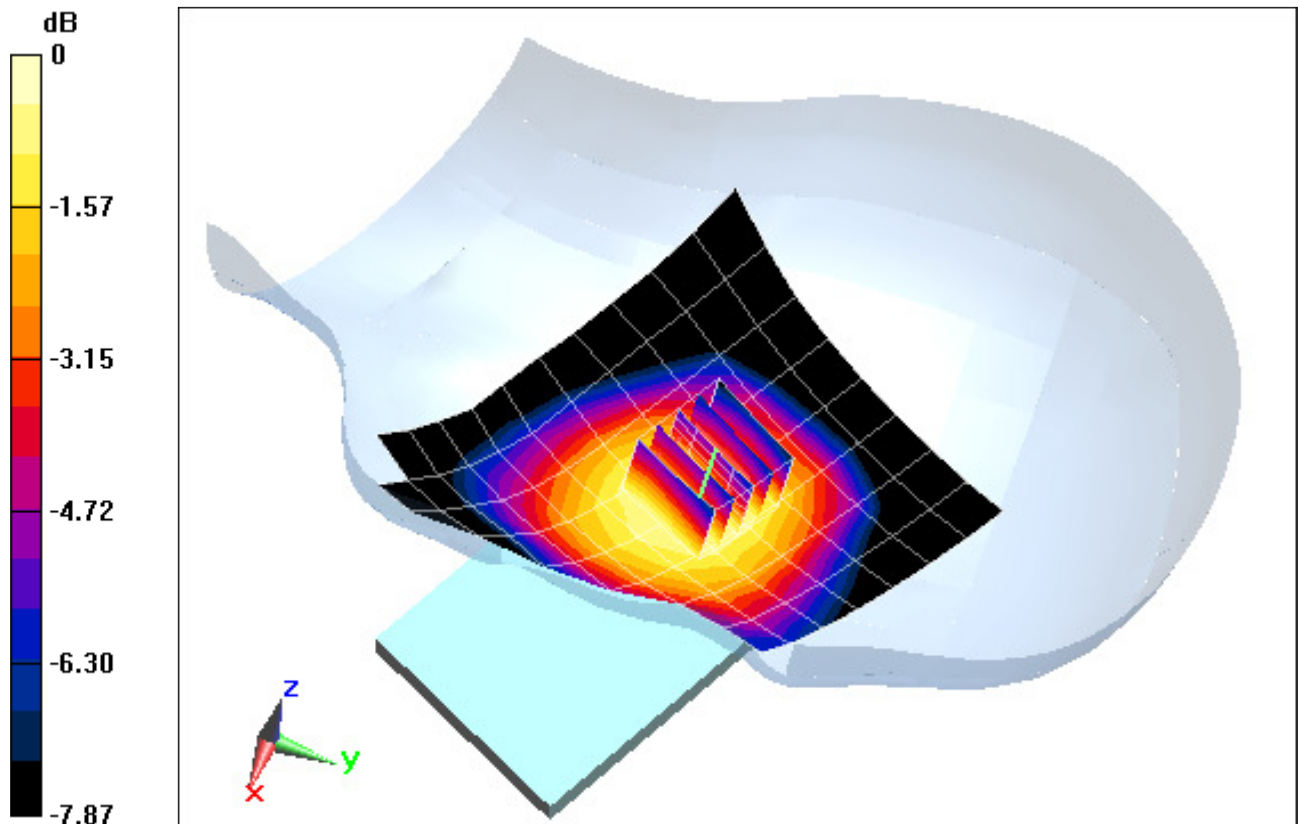

0 dB = 0.119 mW/g = -18.49 dB mW/g

PCTEST ENGINEERING LABORATORY, INC.

DUT: ZNFE970; Type: Portable Handset; Serial: 2G/3G SAR#1

Communication System: GSM850; Frequency: 836.6 MHz; Duty Cycle: 1:8.3

Medium: 835 Head Medium parameters used (interpolated):

$f = 836.6 \text{ MHz}$; $\sigma = 0.908 \text{ mho/m}$; $\epsilon_r = 40.441$; $\rho = 1000 \text{ kg/m}^3$

Phantom section: Right Section

Test Date: 07-05-2012; Ambient Temp: 24.3°C; Tissue Temp: 23.4°C

Probe: ES3DV3 - SN3258; ConvF(6.01, 6.01, 6.01); Calibrated: 2/21/2012;

Sensor-Surface: 4mm (Mechanical Surface Detection)

Electronics: DAE4 Sn1272; Calibrated: 1/18/2012

Phantom: SAM Sub; Type: SAM 4.0; Serial: TP-1403

Measurement SW: DASY4, Version 4.7 (80); SEMCAD X Version 14.6.5 (6469)

Mode: GSM 850, Right Head, Cheek, Mid.ch

Area Scan (7x14x1): Measurement grid: dx=15mm, dy=15mm

Zoom Scan (5x5x7)/Cube 0: Measurement grid: dx=8mm, dy=8mm, dz=5mm

Reference Value = 20.777 V/m; Power Drift = -0.10 dB

Peak SAR (extrapolated) = 0.447 mW/g

SAR(1 g) = 0.370 mW/g; SAR(10 g) = 0.286 mW/g

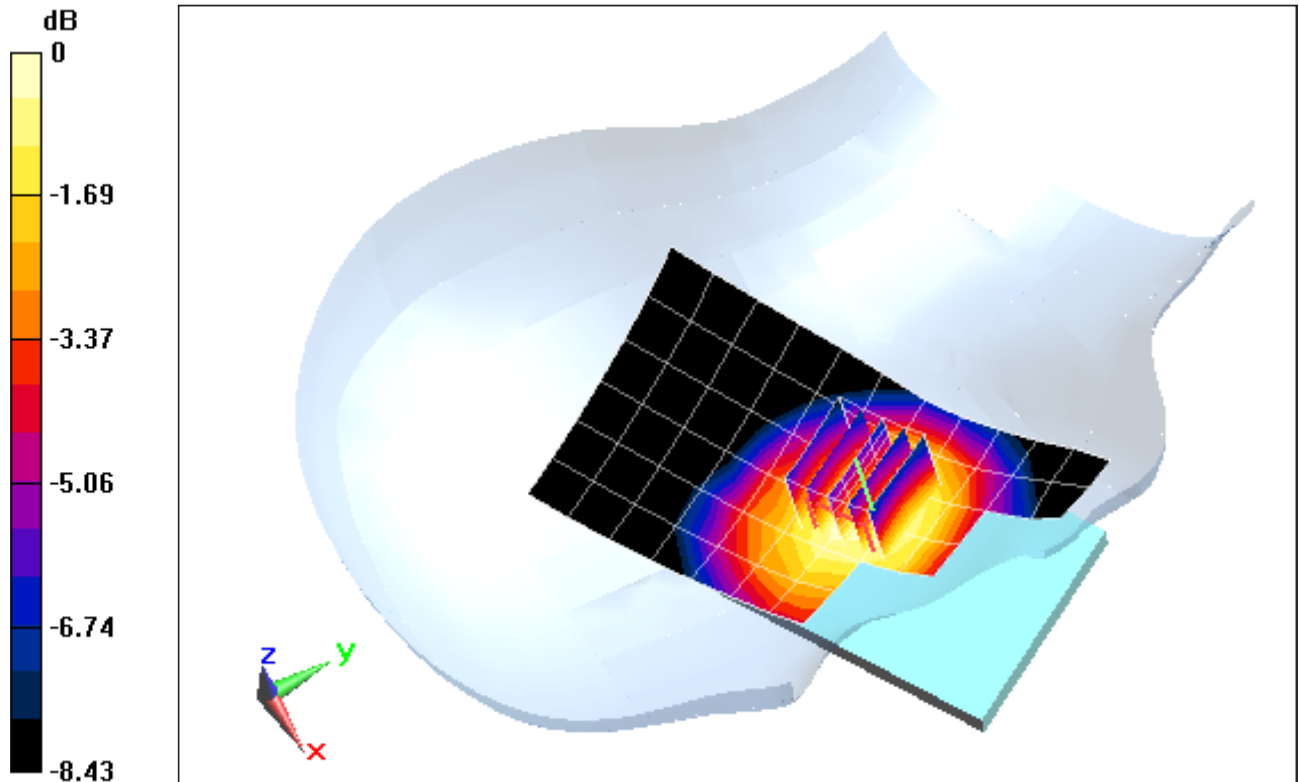

0 dB = 0.387 mW/g = -8.25 dB mW/g

PCTEST ENGINEERING LABORATORY, INC.

DUT: ZNFE970; Type: Portable Handset; Serial: 2G/3G SAR#1

Communication System: GSM850; Frequency: 836.6 MHz; Duty Cycle: 1:8.3

Medium: 835 Head Medium parameters used (interpolated):

$f = 836.6 \text{ MHz}$; $\sigma = 0.908 \text{ mho/m}$; $\epsilon_r = 40.441$; $\rho = 1000 \text{ kg/m}^3$

Phantom section: Right Section

Test Date: 07-05-2012; Ambient Temp: 24.3°C; Tissue Temp: 23.4°C

Probe: ES3DV3 - SN3258; ConvF(6.01, 6.01, 6.01); Calibrated: 2/21/2012;

Sensor-Surface: 4mm (Mechanical Surface Detection)

Electronics: DAE4 Sn1272; Calibrated: 1/18/2012

Phantom: SAM Sub; Type: SAM 4.0; Serial: TP-1403

Measurement SW: DASY4, Version 4.7 (80); SEMCAD X Version 14.6.5 (6469)

Mode: GSM 850, Right Head, Tilt, Mid.ch

Area Scan (7x14x1): Measurement grid: dx=15mm, dy=15mm

Zoom Scan (5x5x7)/Cube 0: Measurement grid: dx=8mm, dy=8mm, dz=5mm

Reference Value = 15.817 V/m; Power Drift = 0.01 dB

Peak SAR (extrapolated) = 0.254 mW/g

SAR(1 g) = 0.215 mW/g; SAR(10 g) = 0.168 mW/g

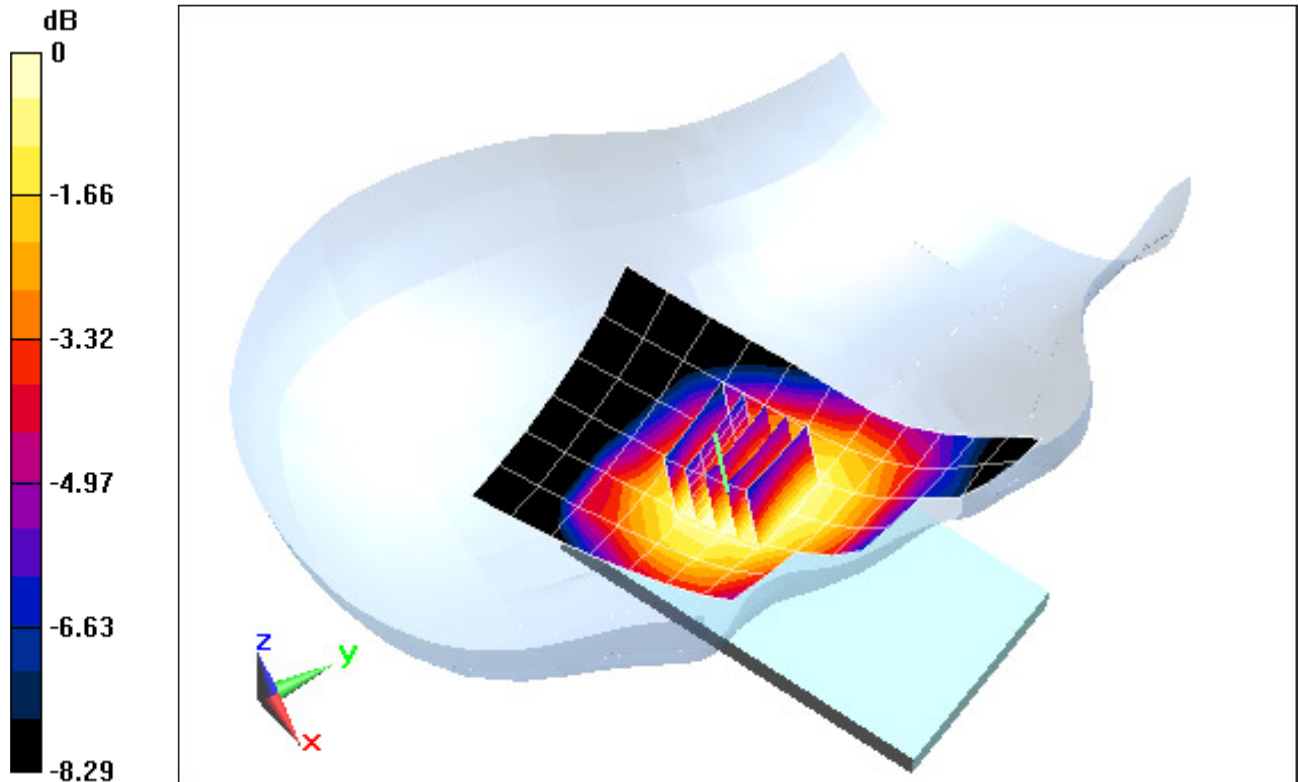

0 dB = 0.222 mW/g = -13.07 dB mW/g

PCTEST ENGINEERING LABORATORY, INC.

DUT: ZNFE970; Type: Portable Handset; Serial: 2G/3G SAR#1

Communication System: GSM850; Frequency: 836.6 MHz; Duty Cycle: 1:8.3

Medium: 835 Head Medium parameters used (interpolated):

$f = 836.6 \text{ MHz}$; $\sigma = 0.908 \text{ mho/m}$; $\epsilon_r = 40.441$; $\rho = 1000 \text{ kg/m}^3$

Phantom section: Left Section

Test Date: 07-05-2012; Ambient Temp: 24.3°C; Tissue Temp: 23.4°C

Probe: ES3DV3 - SN3258; ConvF(6.01, 6.01, 6.01); Calibrated: 2/21/2012;

Sensor-Surface: 4mm (Mechanical Surface Detection)

Electronics: DAE4 Sn1272; Calibrated: 1/18/2012

Phantom: SAM Sub; Type: SAM 4.0; Serial: TP-1403

Measurement SW: DASY4, Version 4.7 (80); SEMCAD X Version 14.6.5 (6469)

Mode: GSM 850, Left Head, Cheek, Mid.ch

Area Scan (7x14x1): Measurement grid: dx=15mm, dy=15mm

Zoom Scan (5x5x7)/Cube 0: Measurement grid: dx=8mm, dy=8mm, dz=5mm

Reference Value = 24.604 V/m; Power Drift = 0.06 dB

Peak SAR (extrapolated) = 0.643 mW/g

SAR(1 g) = 0.501 mW/g; SAR(10 g) = 0.378 mW/g

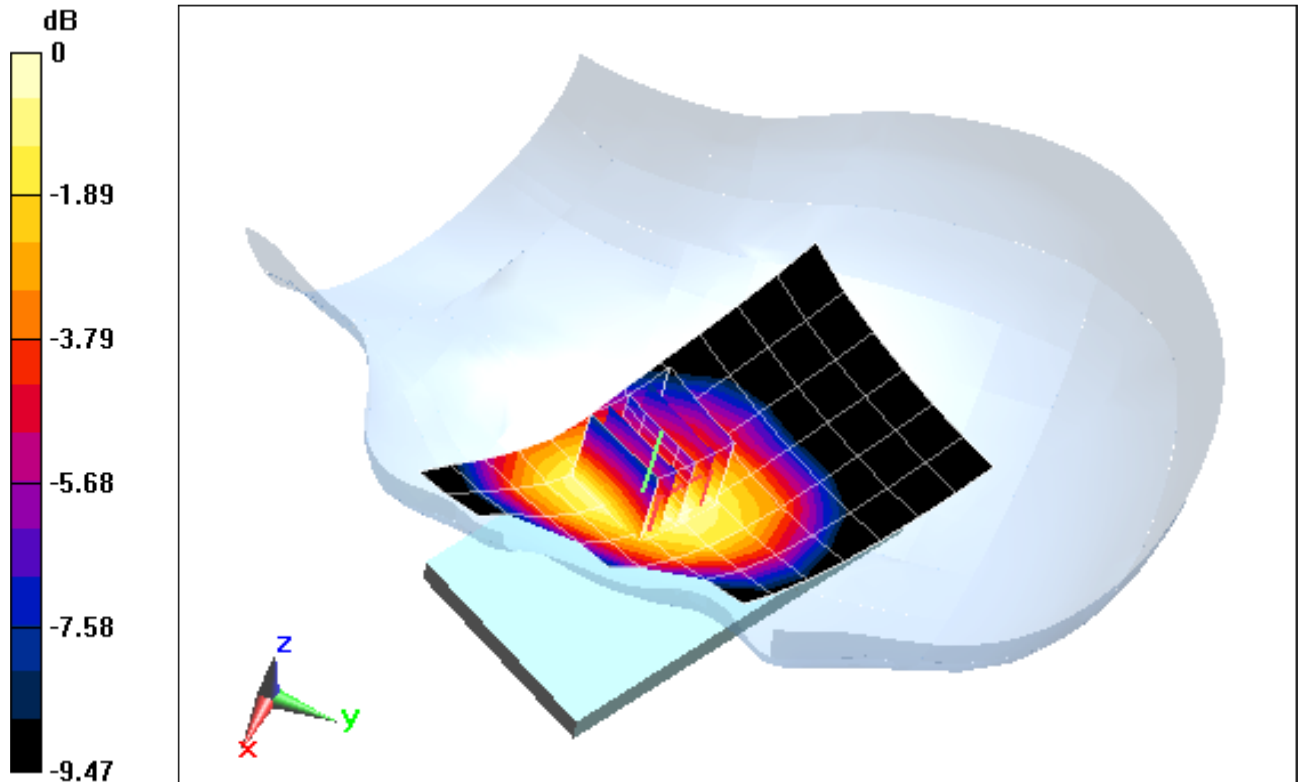

0 dB = 0.528 mW/g = -5.55 dB mW/g

PCTEST ENGINEERING LABORATORY, INC.

DUT: ZNFE970; Type: Portable Handset; Serial: 2G/3G SAR#1

Communication System: GSM850; Frequency: 836.6 MHz; Duty Cycle: 1:8.3

Medium: 835 Head Medium parameters used (interpolated):

$f = 836.6 \text{ MHz}$; $\sigma = 0.908 \text{ mho/m}$; $\epsilon_r = 40.441$; $\rho = 1000 \text{ kg/m}^3$

Phantom section: Left Section

Test Date: 07-05-2012; Ambient Temp: 24.3°C; Tissue Temp: 23.4°C

Probe: ES3DV3 - SN3258; ConvF(6.01, 6.01, 6.01); Calibrated: 2/21/2012;

Sensor-Surface: 4mm (Mechanical Surface Detection)

Electronics: DAE4 Sn1272; Calibrated: 1/18/2012

Phantom: SAM Sub; Type: SAM 4.0; Serial: TP-1403

Measurement SW: DASY4, Version 4.7 (80); SEMCAD X Version 14.6.5 (6469)

Mode: GSM 850, Left Head, Tilt, Mid.ch

Area Scan (7x14x1): Measurement grid: dx=15mm, dy=15mm

Zoom Scan (5x5x7)/Cube 0: Measurement grid: dx=8mm, dy=8mm, dz=5mm

Reference Value = 16.634 V/m; Power Drift = 0.01 dB

Peak SAR (extrapolated) = 0.279 mW/g

SAR(1 g) = 0.237 mW/g; SAR(10 g) = 0.187 mW/g

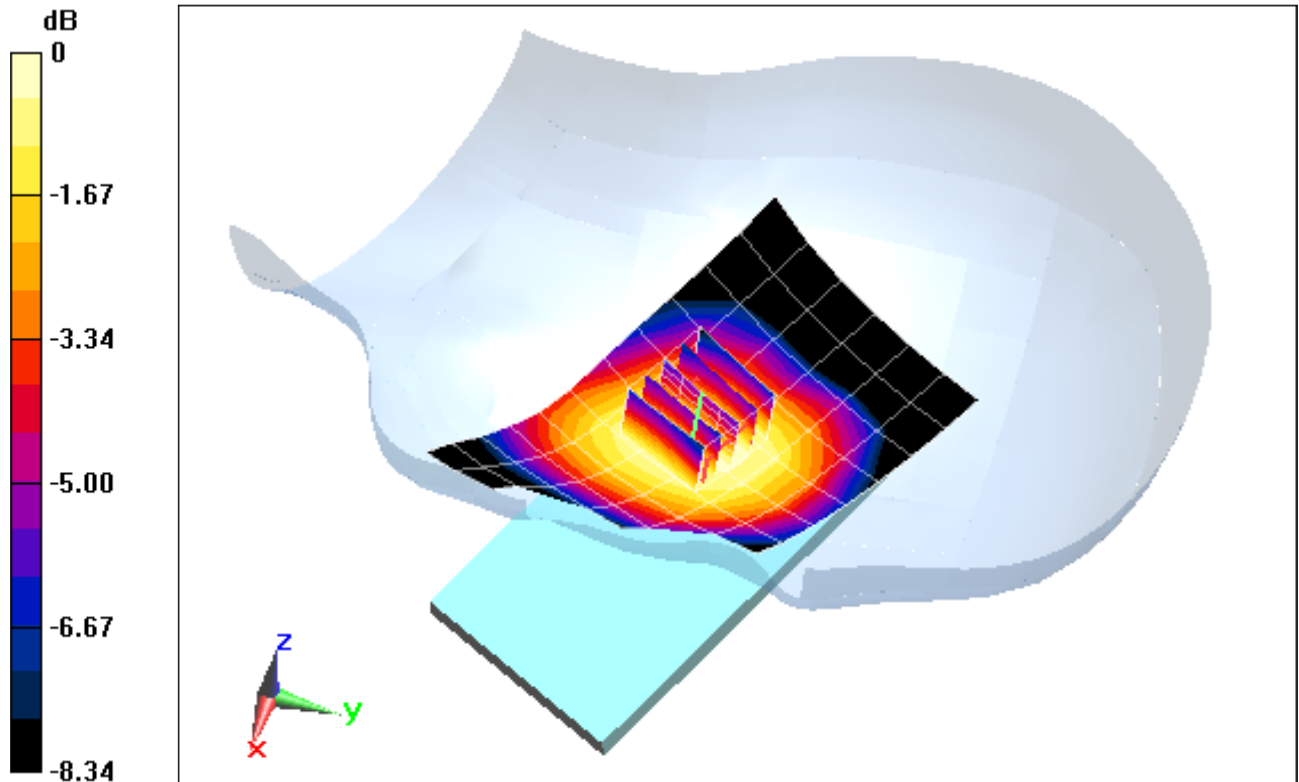

0 dB = 0.248 mW/g = -12.11 dB mW/g

PCTEST ENGINEERING LABORATORY, INC.

*****DUT: ZNFE973; Type: Portable Handset; Serial: 4I 15I 'UCT%3

Communication System: GSM850 GPRS; 2 Tx slots; Frequency: 836.6 MHz; Duty Cycle: 1:4.15

Medium: 835 Head Medium parameters used (interpolated):

$f = 836.6 \text{ MHz}$; $\sigma = 0.894 \text{ mho/m}$; $\epsilon_r = 39.586$; $\rho = 1000 \text{ kg/m}^3$

Phantom section: Right Section

Test Date: 08-22-2012; Ambient Temp: 24.9°C; Tissue Temp: 24.6°C

Probe: ES3DV3 - SN3258; ConvF(6.01, 6.01, 6.01); Calibrated: 2/21/2012;

Sensor-Surface: 4mm (Mechanical Surface Detection)

Electronics: DAE4 Sn1272; Calibrated: 1/18/2012

Phantom: SAM Sub; Type: SAM 4.0; Serial: TP-1403

Measurement SW: DASY4, Version 4.7 (80); SEMCAD X Version 14.6.5 (6469)

Mode: GPRS 850, Right Head, Cheek, Mid.ch, 2 Tx Slots

Area Scan (7x14x1): Measurement grid: dx=15mm, dy=15mm

Zoom Scan (5x5x7)/Cube 0: Measurement grid: dx=8mm, dy=8mm, dz=5mm

Reference Value = 21.476 V/m; Power Drift = -0.05 dB

Peak SAR (extrapolated) = 0.456 mW/g

SAR(1 g) = 0.390 mW/g; SAR(10 g) = 0.306 mW/g

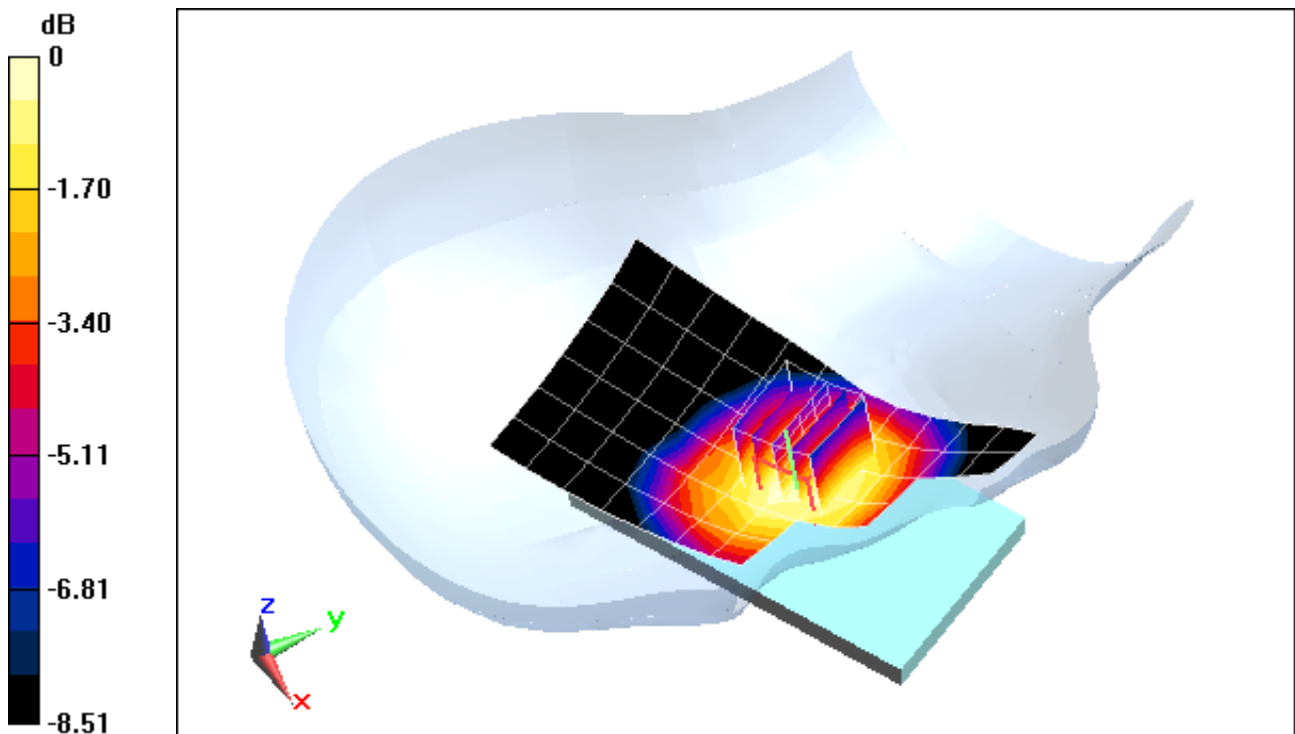

0 dB = 0.406 mW/g = -7.83 dB mW/g

PCTEST ENGINEERING LABORATORY, INC.

""DUT: ZNFE973; Type: Portable Handset; Serial: 4I 15I 'UCT%3

Communication System: GSM850 GPRS; 2 Tx slots; Frequency: 836.6 MHz; Duty Cycle: 1:4.15

Medium: 835 Head Medium parameters used (interpolated):

$f = 836.6 \text{ MHz}$; $\sigma = 0.894 \text{ mho/m}$; $\epsilon_r = 39.586$; $\rho = 1000 \text{ kg/m}^3$

Phantom section: Right Section

Test Date: 08-22-2012; Ambient Temp: 24.9°C; Tissue Temp: 24.6°C

Probe: ES3DV3 - SN3258; ConvF(6.01, 6.01, 6.01); Calibrated: 2/21/2012;

Sensor-Surface: 4mm (Mechanical Surface Detection)

Electronics: DAE4 Sn1272; Calibrated: 1/18/2012

Phantom: SAM Sub; Type: SAM 4.0; Serial: TP-1403

Measurement SW: DASY4, Version 4.7 (80); SEMCAD X Version 14.6.5 (6469)

Mode: GPRS 850, Right Head, Tilt, Mid.ch, 2 Tx Slots

Area Scan (7x14x1): Measurement grid: dx=15mm, dy=15mm

Zoom Scan (5x5x7)/Cube 0: Measurement grid: dx=8mm, dy=8mm, dz=5mm

Reference Value = 15.873 V/m; Power Drift = -0.06 dB

Peak SAR (extrapolated) = 0.243 mW/g

SAR(1 g) = 0.209 mW/g; SAR(10 g) = 0.164 mW/g

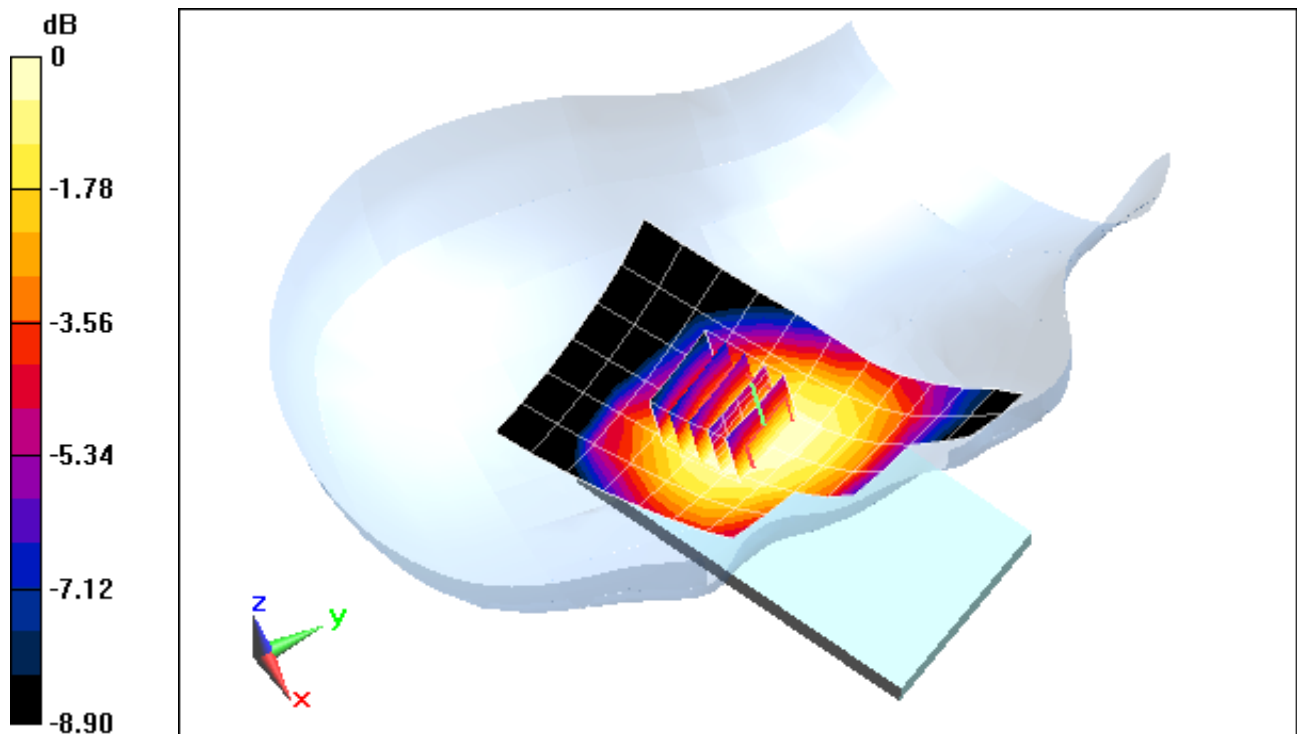

0 dB = 0.218 mW/g = -13.23 dB mW/g

PCTEST ENGINEERING LABORATORY, INC.

*****DUT: ZNFE973; Type: Portable Handset; Serial: 4I 5I 'UCT%

Communication System: GSM850 GPRS; 2 Tx slots; Frequency: 836.6 MHz; Duty Cycle: 1:4.15

Medium: 835 Head Medium parameters used (interpolated):

$f = 836.6 \text{ MHz}$; $\sigma = 0.894 \text{ mho/m}$; $\epsilon_r = 39.586$; $\rho = 1000 \text{ kg/m}^3$

Phantom section: Left Section

Test Date: 08-22-2012; Ambient Temp: 24.9°C; Tissue Temp: 24.6°C

Probe: ES3DV3 - SN3258; ConvF(6.01, 6.01, 6.01); Calibrated: 2/21/2012;

Sensor-Surface: 4mm (Mechanical Surface Detection)

Electronics: DAE4 Sn1272; Calibrated: 1/18/2012

Phantom: SAM Sub; Type: SAM 4.0; Serial: TP-1403

Measurement SW: DASY4, Version 4.7 (80); SEMCAD X Version 14.6.5 (6469)

Mode: GPRS 850, Left Head, Cheek, Mid.ch, 2 Tx Slots

Area Scan (7x14x1): Measurement grid: dx=15mm, dy=15mm

Zoom Scan (5x5x7)/Cube 0: Measurement grid: dx=8mm, dy=8mm, dz=5mm

Reference Value = 26.576 V/m; Power Drift = -0.06 dB

Peak SAR (extrapolated) = 0.750 mW/g

SAR(1 g) = 0.574 mW/g; SAR(10 g) = 0.430 mW/g

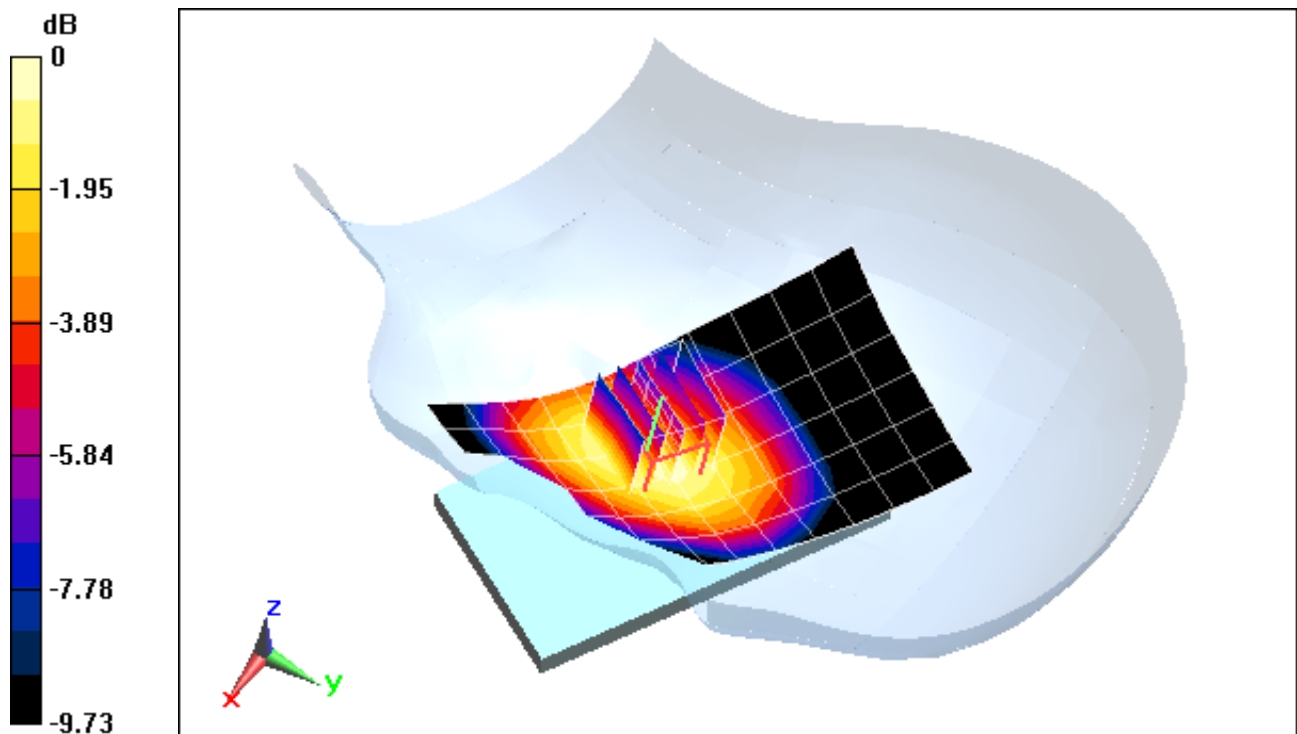

0 dB = 0.602 mW/g = -4.41 dB mW/g

PCTEST ENGINEERING LABORATORY, INC.

*****DUT: ZNFE973; Type: Portable Handset; Serial:'4I 15I 'UCT%

Communication System: GSM850 GPRS; 2 Tx slots; Frequency: 836.6 MHz; Duty Cycle: 1:4.15

Medium: 835 Head Medium parameters used (interpolated):

$f = 836.6 \text{ MHz}$; $\sigma = 0.894 \text{ mho/m}$; $\epsilon_r = 39.586$; $\rho = 1000 \text{ kg/m}^3$

Phantom section: Left Section

Test Date: 08-22-2012; Ambient Temp: 24.9°C; Tissue Temp: 24.6°C

Probe: ES3DV3 - SN3258; ConvF(6.01, 6.01, 6.01); Calibrated: 2/21/2012;

Sensor-Surface: 4mm (Mechanical Surface Detection)

Electronics: DAE4 Sn1272; Calibrated: 1/18/2012

Phantom: SAM Sub; Type: SAM 4.0; Serial: TP-1403

Measurement SW: DASY4, Version 4.7 (80); SEMCAD X Version 14.6.5 (6469)

Mode: GPRS 850, Left Head, Tilt, Mid.ch, 2 Tx Slots

Area Scan (7x14x1): Measurement grid: dx=15mm, dy=15mm

Zoom Scan (5x5x7)/Cube 0: Measurement grid: dx=8mm, dy=8mm, dz=5mm

Reference Value = 17.578 V/m; Power Drift = -0.04 dB

Peak SAR (extrapolated) = 0.305 mW/g

SAR(1 g) = 0.258 mW/g; SAR(10 g) = 0.204 mW/g

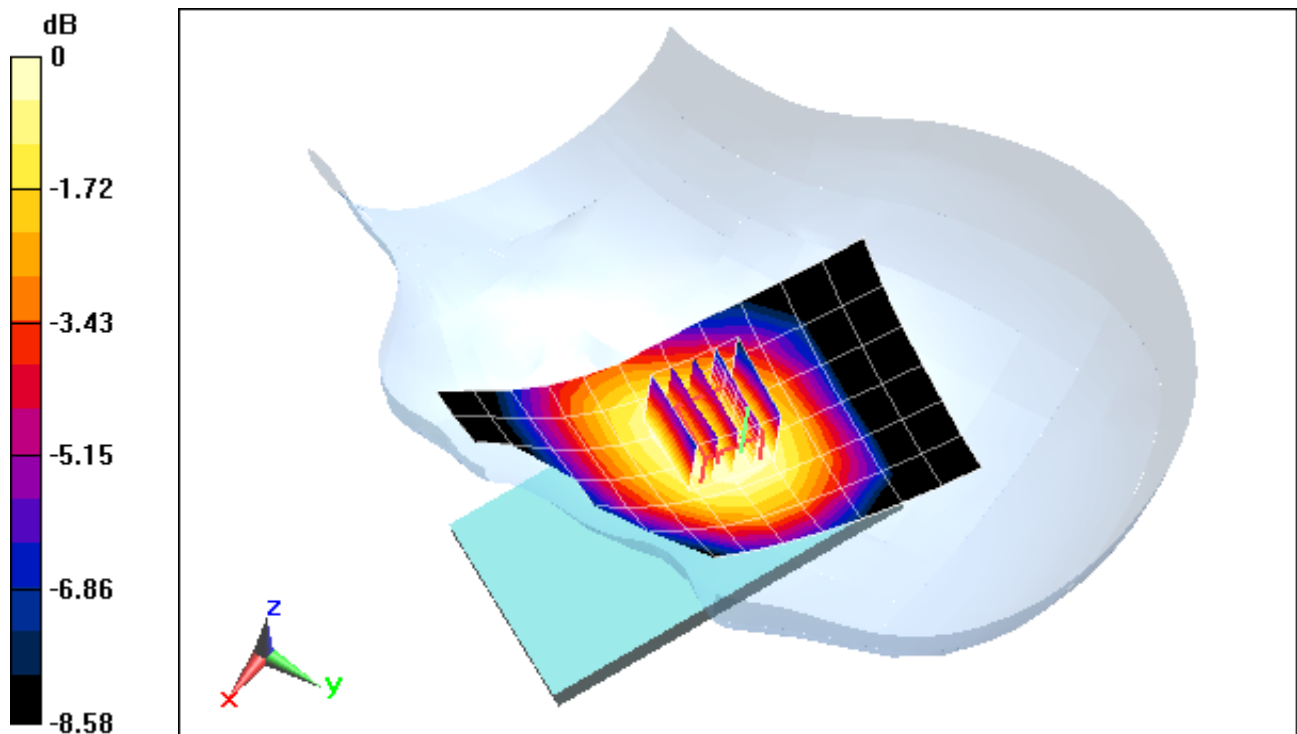

0 dB = 0.266 mW/g = -11.50 dB mW/g

PCTEST ENGINEERING LABORATORY, INC.

DUT: ZNFE970; Type: Portable Handset; Serial: 2G/3G SAR#1

Communication System: WCDMA850; Frequency: 836.6 MHz; Duty Cycle: 1:1
Medium: 835 Head Medium parameters used (interpolated):
 $f = 836.6 \text{ MHz}$; $\sigma = 0.908 \text{ mho/m}$; $\epsilon_r = 40.441$; $\rho = 1000 \text{ kg/m}^3$
Phantom section: Right Section

Test Date: 07-05-2012; Ambient Temp: 24.3°C; Tissue Temp: 23.4°C

Probe: ES3DV3 - SN3258; ConvF(6.01, 6.01, 6.01); Calibrated: 2/21/2012;
Sensor-Surface: 4mm (Mechanical Surface Detection)
Electronics: DAE4 Sn1272; Calibrated: 1/18/2012
Phantom: SAM Sub; Type: SAM 4.0; Serial: TP-1403
Measurement SW: DASY4, Version 4.7 (80); SEMCAD X Version 14.6.5 (6469)

Mode: WCDMA 850, Right Head, Cheek, Mid.ch

Area Scan (7x10x1): Measurement grid: $dx=15\text{mm}$, $dy=15\text{mm}$
Zoom Scan (5x5x7)/Cube 0: Measurement grid: $dx=8\text{mm}$, $dy=8\text{mm}$, $dz=5\text{mm}$
Reference Value = 19.031 V/m; Power Drift = 0.00 dB
Peak SAR (extrapolated) = 0.373 mW/g
SAR(1 g) = 0.311 mW/g; SAR(10 g) = 0.242 mW/g

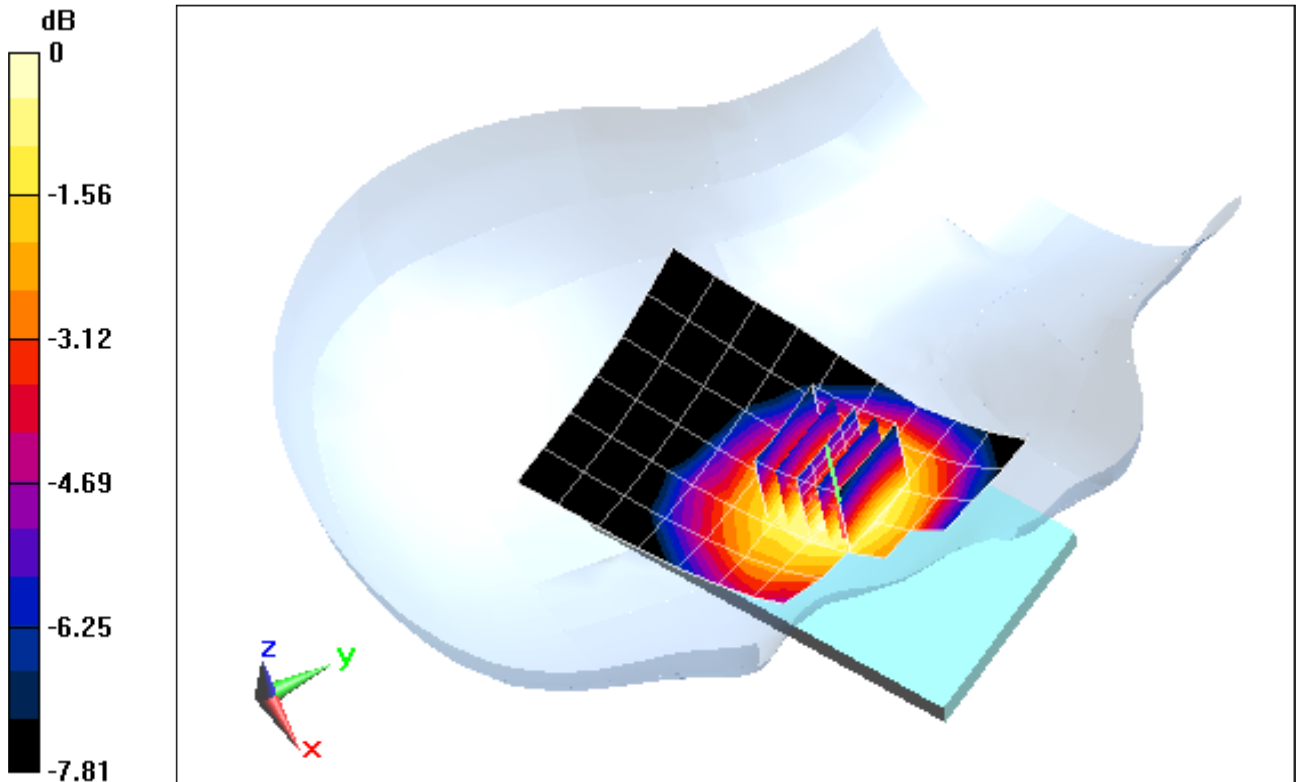

0 dB = 0.325 mW/g = -9.76 dB mW/g

PCTEST ENGINEERING LABORATORY, INC.

DUT: ZNFE970; Type: Portable Handset; Serial: 2G/3G SAR#1

Communication System: WCDMA850; Frequency: 836.6 MHz; Duty Cycle: 1:1
Medium: 835 Head Medium parameters used (interpolated):
 $f = 836.6 \text{ MHz}$; $\sigma = 0.908 \text{ mho/m}$; $\epsilon_r = 40.441$; $\rho = 1000 \text{ kg/m}^3$
Phantom section: Right Section

Test Date: 07-05-2012; Ambient Temp: 24.3°C; Tissue Temp: 23.4°C

Probe: ES3DV3 - SN3258; ConvF(6.01, 6.01, 6.01); Calibrated: 2/21/2012;
Sensor-Surface: 4mm (Mechanical Surface Detection)
Electronics: DAE4 Sn1272; Calibrated: 1/18/2012
Phantom: SAM Sub; Type: SAM 4.0; Serial: TP-1403
Measurement SW: DASY4, Version 4.7 (80); SEMCAD X Version 14.6.5 (6469)

Mode: WCDMA 850, Right Head, Tilt, Mid.ch

Area Scan (7x10x1): Measurement grid: dx=15mm, dy=15mm
Zoom Scan (5x5x7)/Cube 0: Measurement grid: dx=8mm, dy=8mm, dz=5mm
Reference Value = 14.731 V/m; Power Drift = -0.03 dB
Peak SAR (extrapolated) = 0.214 mW/g
SAR(1 g) = 0.183 mW/g; SAR(10 g) = 0.144 mW/g

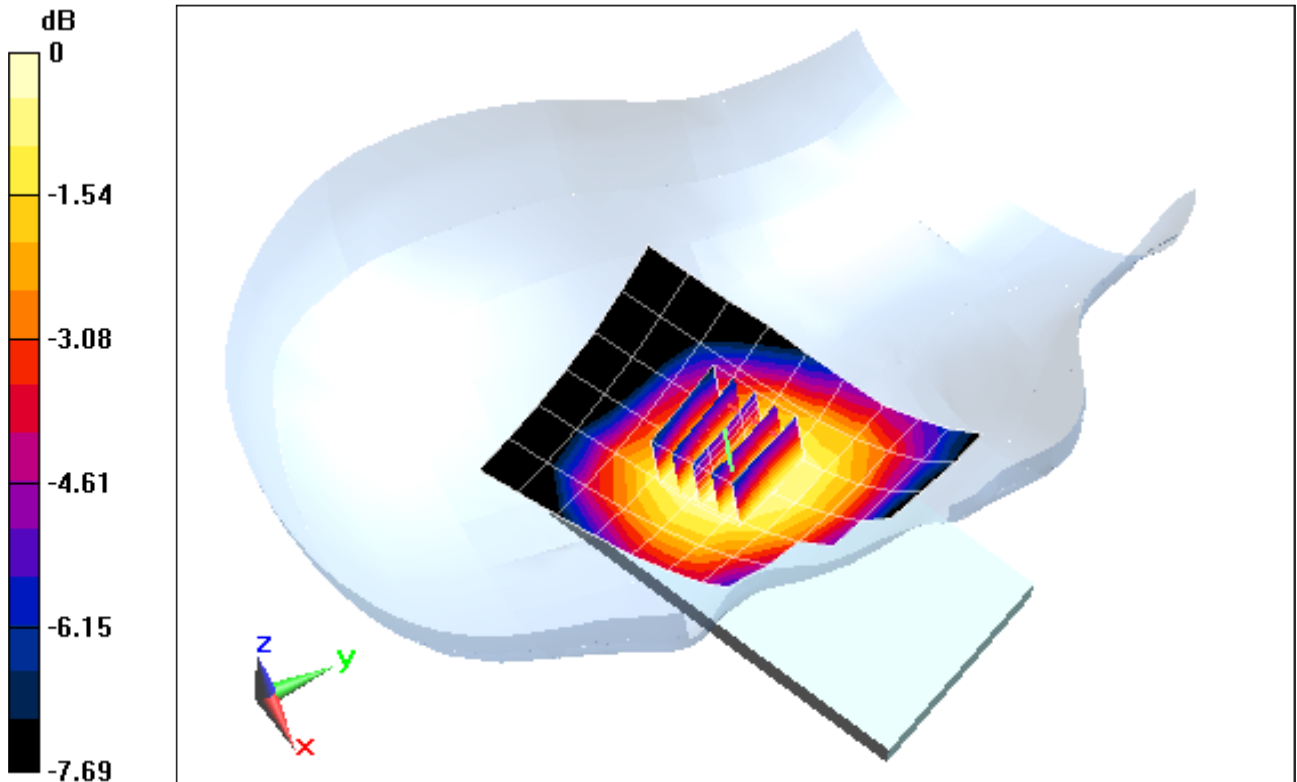

0 dB = 0.191 mW/g = -14.38 dB mW/g

PCTEST ENGINEERING LABORATORY, INC.

DUT: ZNFE970; Type: Portable Handset; Serial: 2G/3G SAR#1

Communication System: WCDMA850; Frequency: 836.6 MHz; Duty Cycle: 1:1

Medium: 835 Head Medium parameters used (interpolated):

$f = 836.6 \text{ MHz}$; $\sigma = 0.908 \text{ mho/m}$; $\epsilon_r = 40.441$; $\rho = 1000 \text{ kg/m}^3$

Phantom section: Left Section

Test Date: 07-05-2012; Ambient Temp: 24.3°C; Tissue Temp: 23.4°C

Probe: ES3DV3 - SN3258; ConvF(6.01, 6.01, 6.01); Calibrated: 2/21/2012;

Sensor-Surface: 4mm (Mechanical Surface Detection)

Electronics: DAE4 Sn1272; Calibrated: 1/18/2012

Phantom: SAM Sub; Type: SAM 4.0; Serial: TP-1403

Measurement SW: DASY4, Version 4.7 (80); SEMCAD X Version 14.6.5 (6469)

Mode: WCDMA 850, Left Head, Cheek, Mid.ch

Area Scan (7x10x1): Measurement grid: $dx=15\text{mm}$, $dy=15\text{mm}$

Zoom Scan (5x5x7)/Cube 0: Measurement grid: $dx=8\text{mm}$, $dy=8\text{mm}$, $dz=5\text{mm}$

Reference Value = 22.268 V/m; Power Drift = 0.03 dB

Peak SAR (extrapolated) = 0.538 mW/g

SAR(1 g) = 0.419 mW/g; SAR(10 g) = 0.315 mW/g

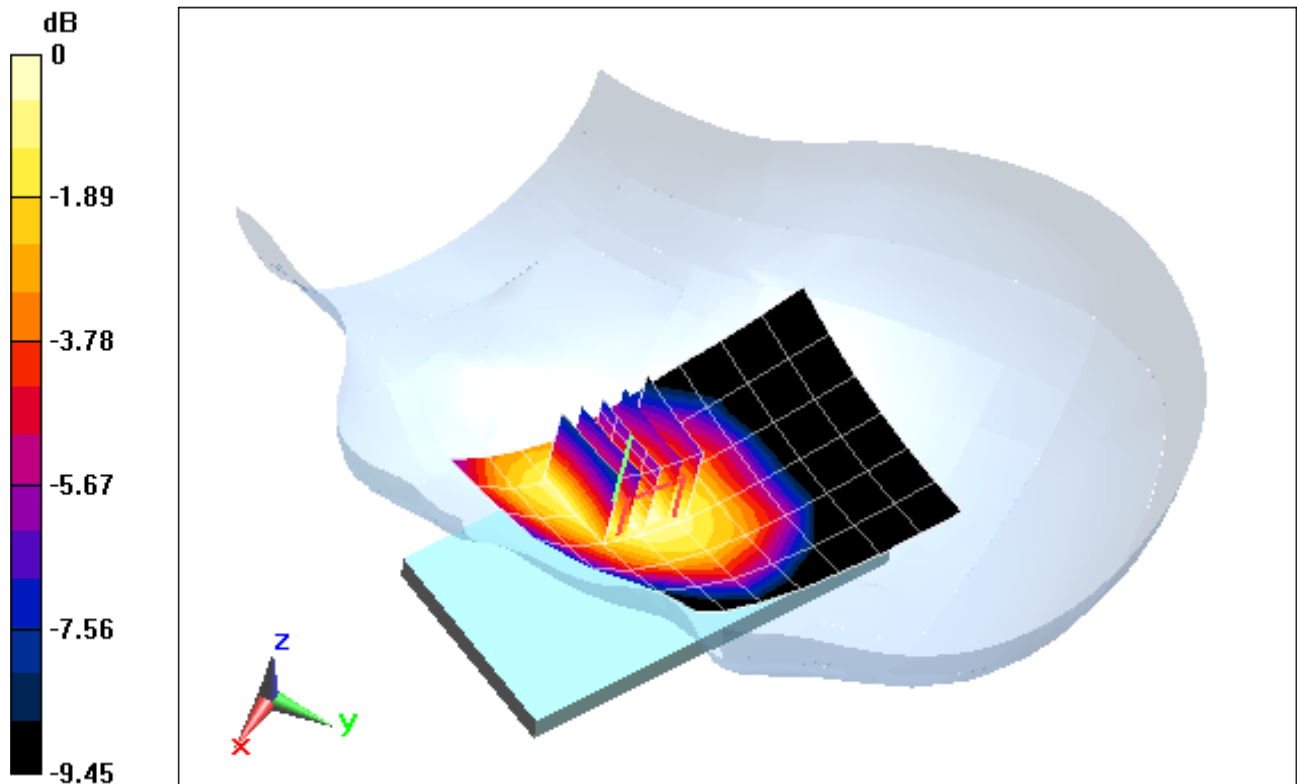

0 dB = 0.440 mW/g = -7.13 dB mW/g

PCTEST ENGINEERING LABORATORY, INC.

DUT: ZNFE970; Type: Portable Handset; Serial: 2G/3G SAR#1

Communication System: WCDMA850; Frequency: 836.6 MHz; Duty Cycle: 1:1
Medium: 835 Head Medium parameters used (interpolated):
 $f = 836.6 \text{ MHz}$; $\sigma = 0.908 \text{ mho/m}$; $\epsilon_r = 40.441$; $\rho = 1000 \text{ kg/m}^3$
Phantom section: Left Section

Test Date: 07-05-2012; Ambient Temp: 24.3°C; Tissue Temp: 23.4°C

Probe: ES3DV3 - SN3258; ConvF(6.01, 6.01, 6.01); Calibrated: 2/21/2012;
Sensor-Surface: 4mm (Mechanical Surface Detection)
Electronics: DAE4 Sn1272; Calibrated: 1/18/2012
Phantom: SAM Sub; Type: SAM 4.0; Serial: TP-1403
Measurement SW: DASY4, Version 4.7 (80); SEMCAD X Version 14.6.5 (6469)

Mode: WCDMA 850, Left Head, Tilt, Mid.ch

Area Scan (7x10x1): Measurement grid: dx=15mm, dy=15mm
Zoom Scan (5x5x7)/Cube 0: Measurement grid: dx=8mm, dy=8mm, dz=5mm
Reference Value = 15.521 V/m; Power Drift = -0.01 dB
Peak SAR (extrapolated) = 0.243 mW/g
SAR(1 g) = 0.208 mW/g; SAR(10 g) = 0.165 mW/g

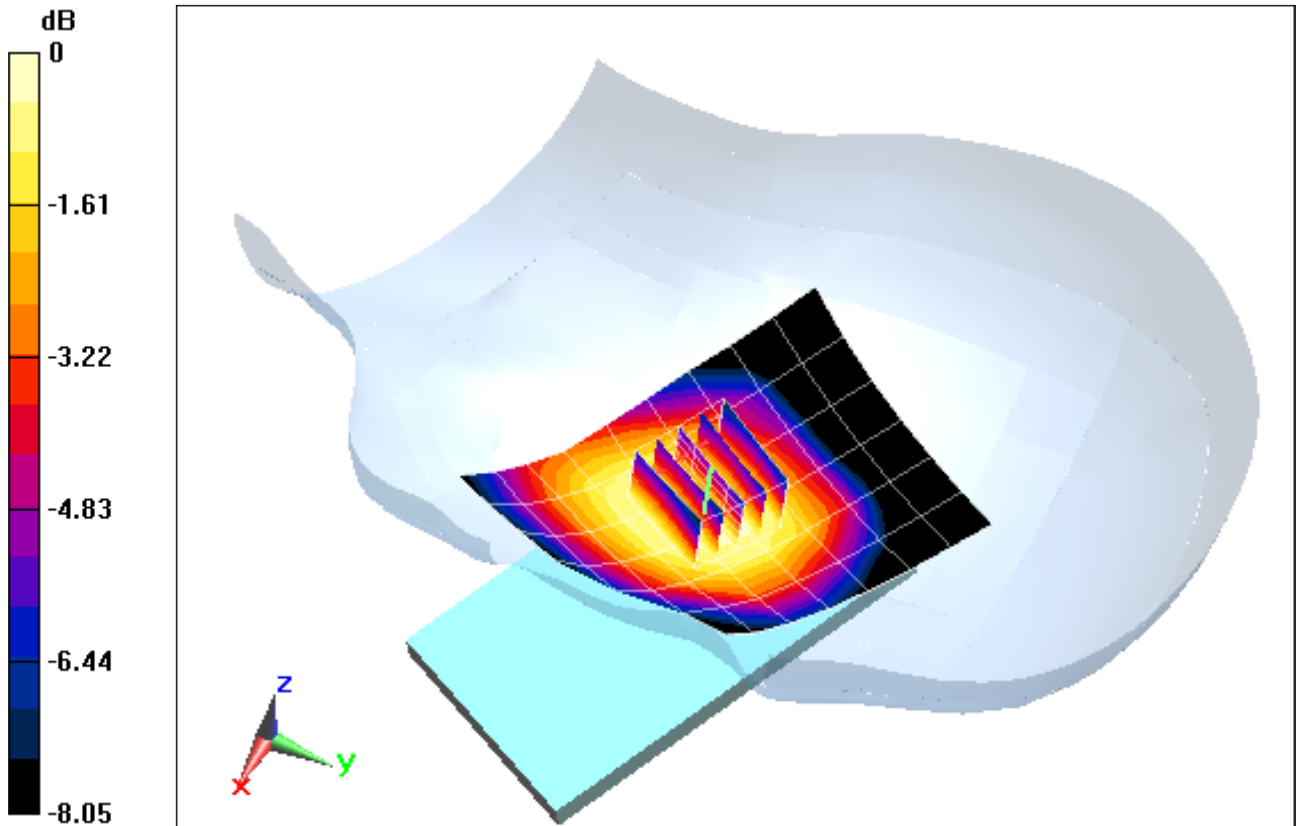

0 dB = 0.217 mW/g = -13.27 dB mW/g

PCTEST ENGINEERING LABORATORY, INC.

DUT: ZNFE970; Type: Portable Handset; Serial: LTE SAR#1

Communication System: LTE BAND 5; Frequency: 844 MHz; Duty Cycle: 1:1
Medium: 835 Head Medium parameters used (interpolated):
 $f = 844 \text{ MHz}$; $\sigma = 0.916 \text{ mho/m}$; $\epsilon_r = 40.352$; $\rho = 1000 \text{ kg/m}^3$
Phantom section: Right Section

Test Date: 07-05-2012; Ambient Temp: 24.3°C; Tissue Temp: 23.4°C

Probe: ES3DV3 - SN3258; ConvF(6.01, 6.01, 6.01); Calibrated: 2/21/2012;
Sensor-Surface: 4mm (Mechanical Surface Detection)
Electronics: DAE4 Sn1272; Calibrated: 1/18/2012
Phantom: SAM Sub; Type: SAM 4.0; Serial: TP-1403
Measurement SW: DASY52, Version 52.8 (1); SEMCAD X Version 14.6.5 (6469)

Mode: LTE Band 5 (Cell), Right Head, Cheek, High.ch
10 MHz Bandwidth, QPSK, 1 RB, 49 RB Offset

Area Scan (7x14x1): Measurement grid: dx=15mm, dy=15mm
Zoom Scan (5x5x7)/Cube 0: Measurement grid: dx=8mm, dy=8mm, dz=5mm
Reference Value = 21.245 V/m; Power Drift = -0.05 dB
Peak SAR (extrapolated) = 0.445 mW/g
SAR(1 g) = 0.371 mW/g; SAR(10 g) = 0.283 mW/g

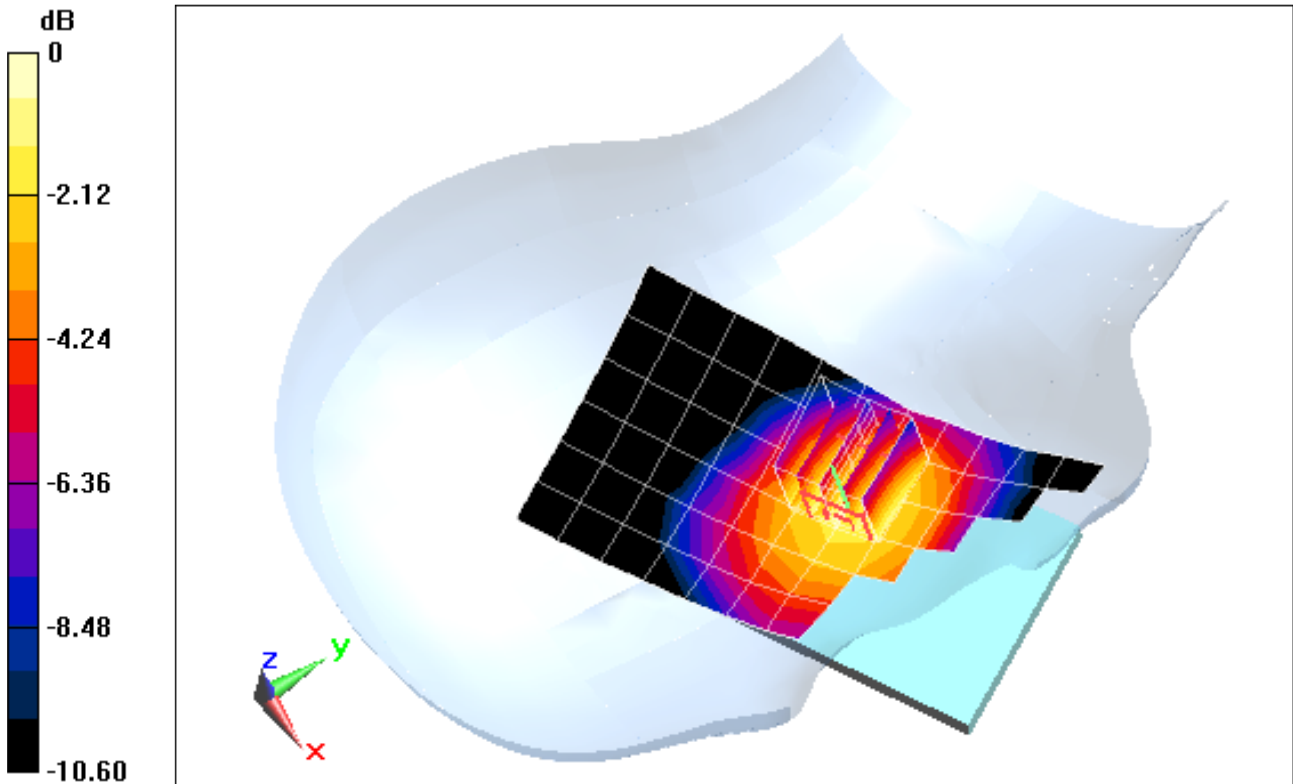

0 dB = 0.386 mW/g = -8.27 dB mW/g

PCTEST ENGINEERING LABORATORY, INC.

DUT: ZNFE970; Type: Portable Handset; Serial: LTE SAR#1

Communication System: LTE BAND 5; Frequency: 844 MHz; Duty Cycle: 1:1
Medium: 835 Head Medium parameters used (interpolated):
 $f = 844 \text{ MHz}$; $\sigma = 0.916 \text{ mho/m}$; $\epsilon_r = 40.352$; $\rho = 1000 \text{ kg/m}^3$
Phantom section: Right Section

Test Date: 07-05-2012; Ambient Temp: 24.3°C; Tissue Temp: 23.4°C

Probe: ES3DV3 - SN3258; ConvF(6.01, 6.01, 6.01); Calibrated: 2/21/2012;
Sensor-Surface: 4mm (Mechanical Surface Detection)
Electronics: DAE4 Sn1272; Calibrated: 1/18/2012
Phantom: SAM Sub; Type: SAM 4.0; Serial: TP-1403
Measurement SW: DASY52, Version 52.8 (1); SEMCAD X Version 14.6.5 (6469)

Mode: LTE Band 5 (Cell), Right Head, Tilt, High.ch
10 MHz Bandwidth, QPSK, 1 RB, 49 RB Offset

Area Scan (7x14x1): Measurement grid: dx=15mm, dy=15mm
Zoom Scan (5x5x7)/Cube 0: Measurement grid: dx=8mm, dy=8mm, dz=5mm
Reference Value = 16.465 V/m; Power Drift = 0.02 dB
Peak SAR (extrapolated) = 0.256 mW/g
SAR(1 g) = 0.216 mW/g; SAR(10 g) = 0.170 mW/g

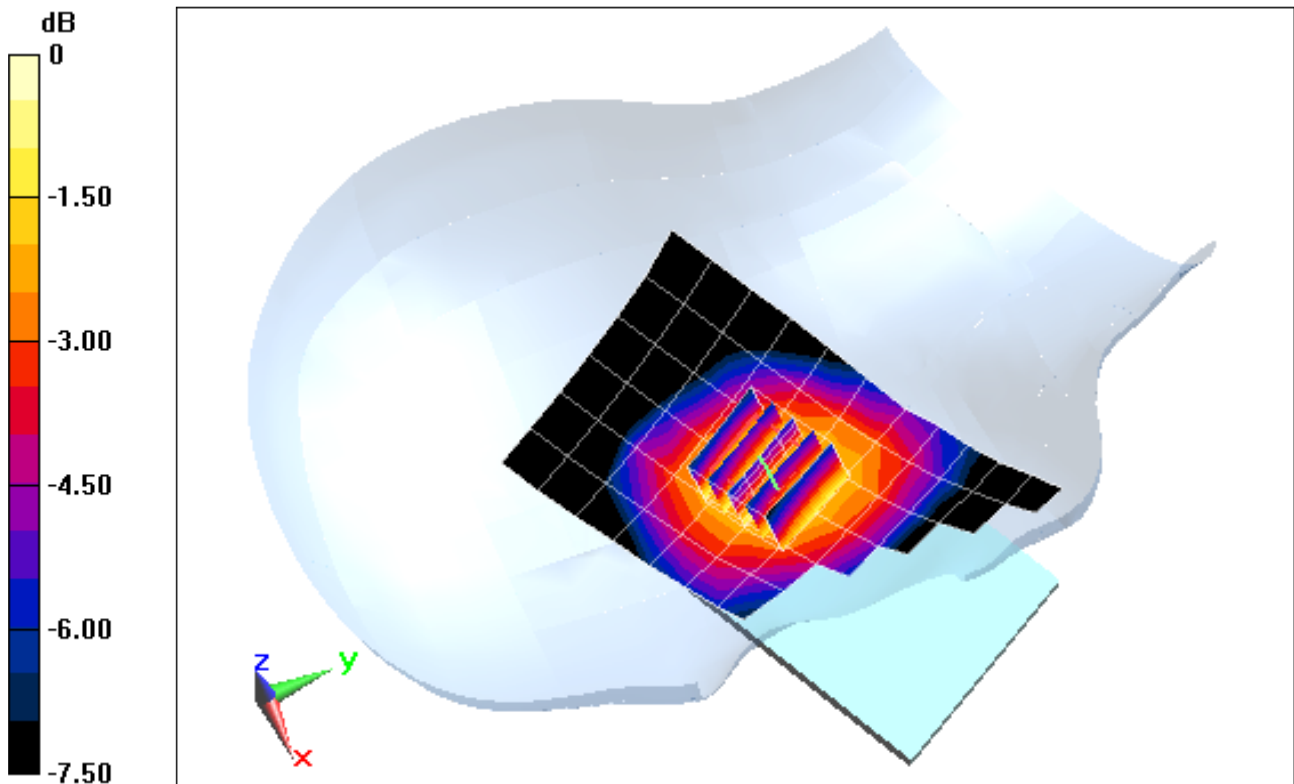

0 dB = 0.226 mW/g = -12.92 dB mW/g

PCTEST ENGINEERING LABORATORY, INC.

DUT: ZNFE970; Type: Portable Handset; Serial: LTE SAR#1

Communication System: LTE BAND 5; Frequency: 844 MHz; Duty Cycle: 1:1
Medium: 835 Head Medium parameters used (interpolated):
 $f = 844 \text{ MHz}$; $\sigma = 0.916 \text{ mho/m}$; $\epsilon_r = 40.352$; $\rho = 1000 \text{ kg/m}^3$
Phantom section: Left Section

Test Date: 07-05-2012; Ambient Temp: 24.3°C; Tissue Temp: 23.4°C

Probe: ES3DV3 - SN3258; ConvF(6.01, 6.01, 6.01); Calibrated: 2/21/2012;
Sensor-Surface: 4mm (Mechanical Surface Detection)
Electronics: DAE4 Sn1272; Calibrated: 1/18/2012
Phantom: SAM Sub; Type: SAM 4.0; Serial: TP-1403
Measurement SW: DASY52, Version 52.8 (1); SEMCAD X Version 14.6.5 (6469)

Mode: LTE Band 5 (Cell), Left Head, Cheek, High. Ch
10 MHz Bandwidth, QPSK, 1 RB, 49 RB Offset

Area Scan (7x14x1): Measurement grid: dx=15mm, dy=15mm
Zoom Scan (5x5x7)/Cube 0: Measurement grid: dx=8mm, dy=8mm, dz=5mm
Reference Value = 25.172 V/m; Power Drift = 0.01 dB
Peak SAR (extrapolated) = 0.637 mW/g
SAR(1 g) = 0.493 mW/g; SAR(10 g) = 0.370 mW/g

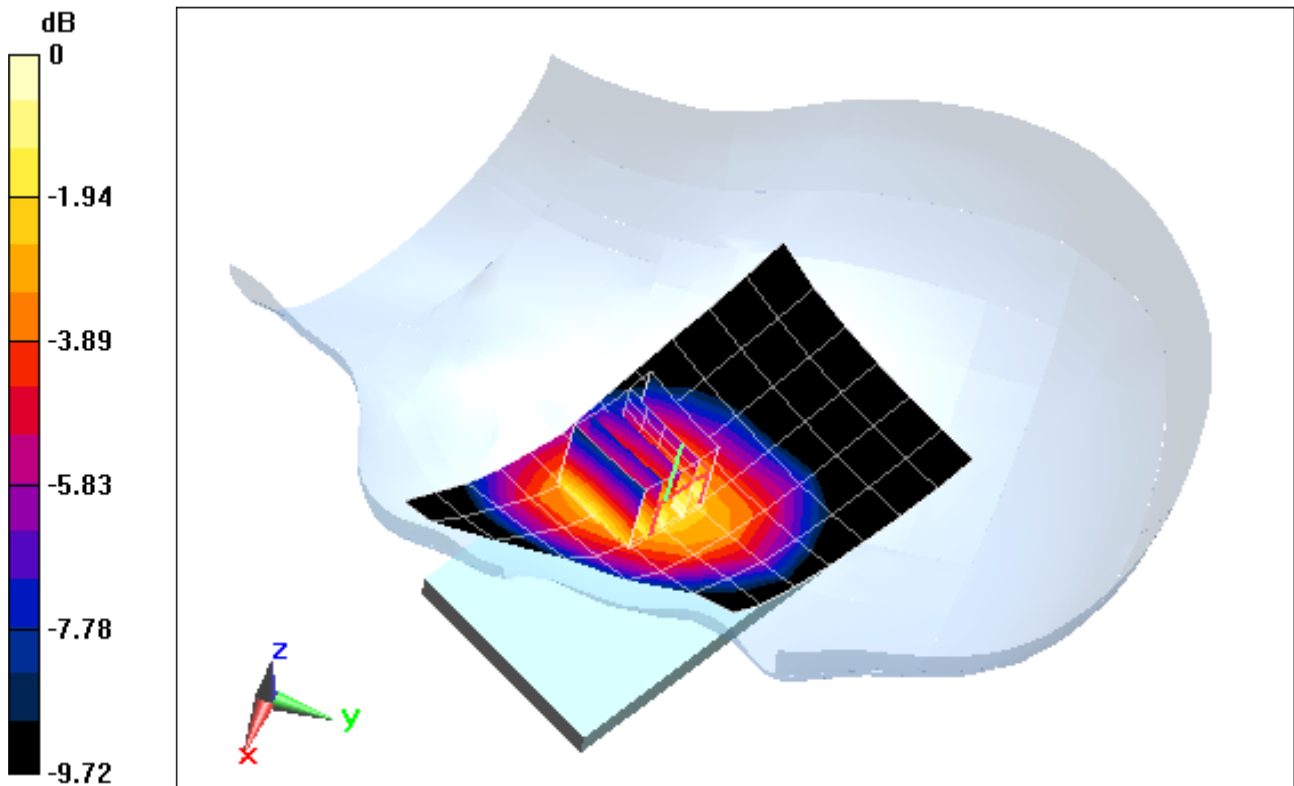

0 dB = 0.512 mW/g = -5.81 dB mW/g

PCTEST ENGINEERING LABORATORY, INC.

DUT: ZNFE970; Type: Portable Handset; Serial: LTE SAR#1

Communication System: LTE BAND 5; Frequency: 844 MHz; Duty Cycle: 1:1
Medium: 835 Head Medium parameters used (interpolated):
 $f = 844 \text{ MHz}$; $\sigma = 0.916 \text{ mho/m}$; $\epsilon_r = 40.352$; $\rho = 1000 \text{ kg/m}^3$
Phantom section: Left Section

Test Date: 07-05-2012; Ambient Temp: 24.3°C; Tissue Temp: 23.4°C

Probe: ES3DV3 - SN3258; ConvF(6.01, 6.01, 6.01); Calibrated: 2/21/2012;
Sensor-Surface: 4mm (Mechanical Surface Detection)
Electronics: DAE4 Sn1272; Calibrated: 1/18/2012
Phantom: SAM Sub; Type: SAM 4.0; Serial: TP-1403
Measurement SW: DASY52, Version 52.8 (1); SEMCAD X Version 14.6.5 (6469)

Mode: LTE Band 5 (Cell), Left Head, Tilt, High.ch
10 MHz Bandwidth, QPSK, 1 RB, 49 RB Offset

Area Scan (7x14x1): Measurement grid: $dx=15\text{mm}$, $dy=15\text{mm}$
Zoom Scan (5x5x7)/Cube 0: Measurement grid: $dx=8\text{mm}$, $dy=8\text{mm}$, $dz=5\text{mm}$
Reference Value = 17.072 V/m; Power Drift = 0.18 dB
Peak SAR (extrapolated) = 0.300 mW/g
SAR(1 g) = 0.247 mW/g; SAR(10 g) = 0.190 mW/g

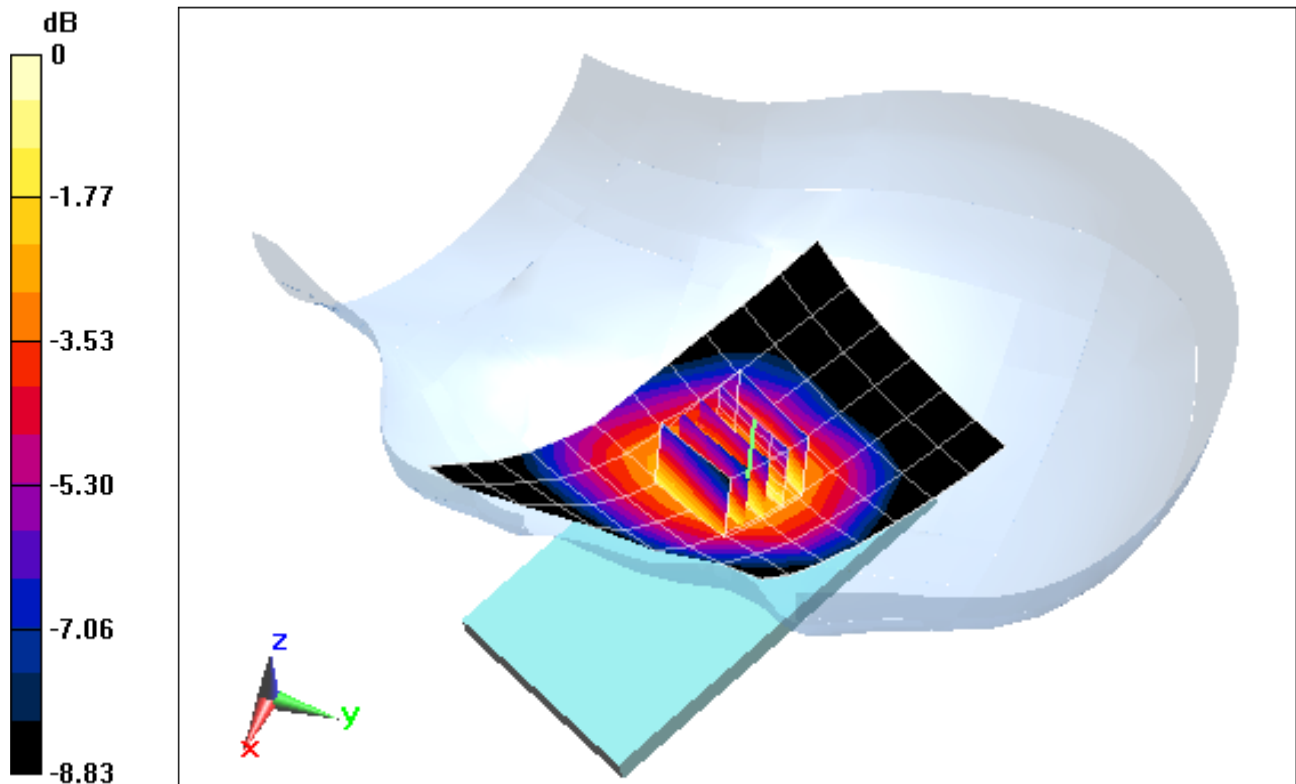

0 dB = 0.258 mW/g = -11.77 dB mW/g

PCTEST ENGINEERING LABORATORY, INC.

DUT: ZNFE970; Type: Portable Handset; Serial: LTE SAR#1

Communication System: LTE RF; Frequency: 1715 MHz; Duty Cycle: 1:1

Medium: 1750 Head Medium parameters used (interpolated):

$f = 1715 \text{ MHz}$; $\sigma = 1.359 \text{ mho/m}$; $\epsilon_r = 39.038$; $\rho = 1000 \text{ kg/m}^3$

Phantom section: Right Section

Test Date: 07-06-2012; Ambient Temp: 23.9°C; Tissue Temp: 23.1°C

Probe: ES3DV2 - SN3022; ConvF(5.2, 5.2, 5.2); Calibrated: 8/25/2011;

Sensor-Surface: 4mm (Mechanical Surface Detection)

Electronics: DAE4 Sn665; Calibrated: 4/19/2012

Phantom: SAM with CRP; Type: SAM; Serial: TP1375

Measurement SW: DASY4, Version 4.7 (80); SEMCAD X Version 14.6.5 (6469)

Mode: LTE Band 4 (AWS), Right Head, Cheek, Low.ch
10 MHz Bandwidth, QPSK, 1 RB, 0 RB Offset

Area Scan (7x14x1): Measurement grid: dx=15mm, dy=15mm

Zoom Scan (5x5x7)/Cube 0: Measurement grid: dx=8mm, dy=8mm, dz=5mm

Reference Value = 24.616 V/m; Power Drift = -0.12 dB

Peak SAR (extrapolated) = 0.990 mW/g

SAR(1 g) = 0.671 mW/g; SAR(10 g) = 0.427 mW/g

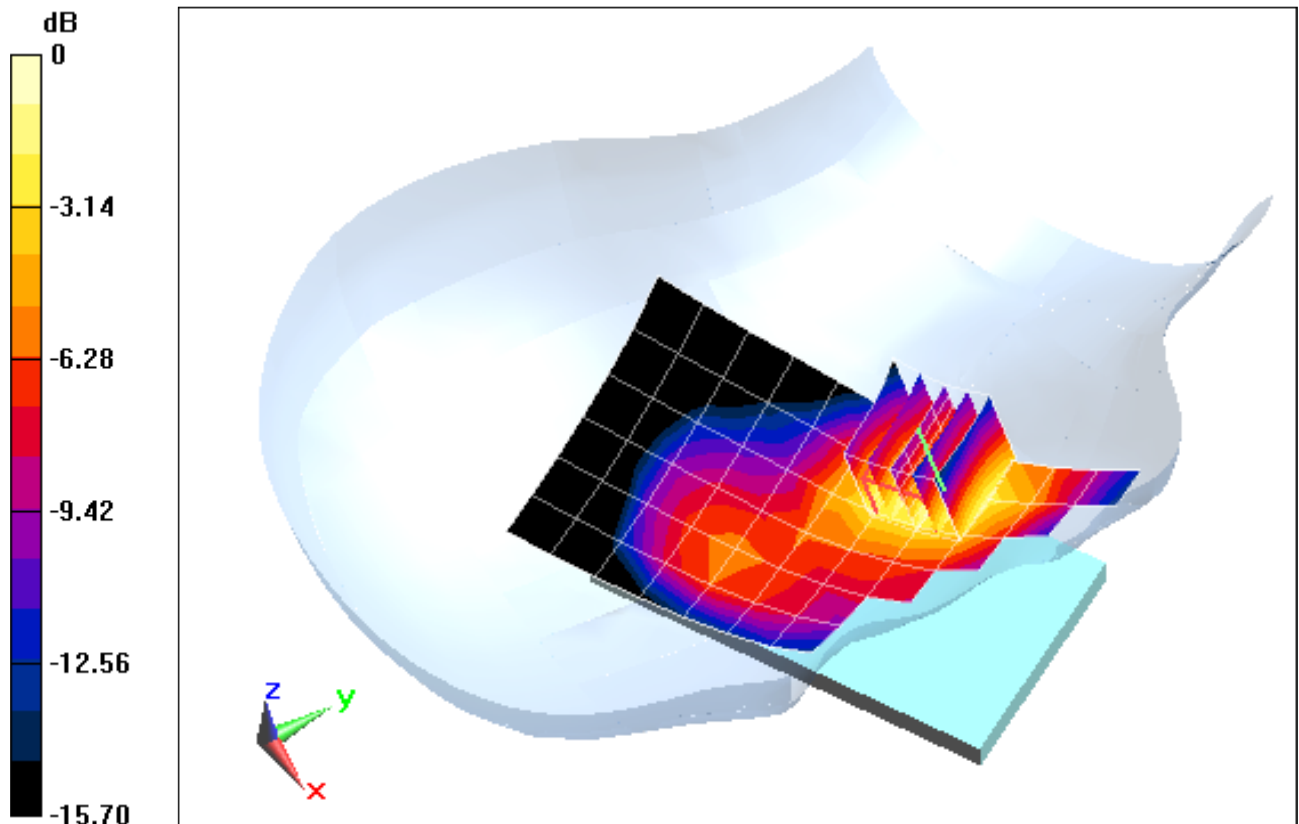

0 dB = 0.698 mW/g = -3.12 dB mW/g

PCTEST ENGINEERING LABORATORY, INC.

DUT: ZNFE970; Type: Portable Handset; Serial: LTE SAR#1

Communication System: LTE RF; Frequency: 1715 MHz; Duty Cycle: 1:1

Medium: 1750 Head Medium parameters used (interpolated):

$f = 1715 \text{ MHz}$; $\sigma = 1.359 \text{ mho/m}$; $\epsilon_r = 39.038$; $\rho = 1000 \text{ kg/m}^3$

Phantom section: Right Section

Test Date: 07-06-2012; Ambient Temp: 23.9°C; Tissue Temp: 23.1°C

Probe: ES3DV2 - SN3022; ConvF(5.2, 5.2, 5.2); Calibrated: 8/25/2011;

Sensor-Surface: 4mm (Mechanical Surface Detection)

Electronics: DAE4 Sn665; Calibrated: 4/19/2012

Phantom: SAM with CRP; Type: SAM; Serial: TP1375

Measurement SW: DASY4, Version 4.7 (80); SEMCAD X Version 14.6.5 (6469)

Mode: LTE Band 4 (AWS), Right Head, Tilt, Low.ch
10 MHz Bandwidth, QPSK, 1 RB, 0 RB Offset

Area Scan (7x14x1): Measurement grid: dx=15mm, dy=15mm

Zoom Scan (5x5x7)/Cube 0: Measurement grid: dx=8mm, dy=8mm, dz=5mm

Reference Value = 16.161 V/m; Power Drift = 0.07 dB

Peak SAR (extrapolated) = 0.442 mW/g

SAR(1 g) = 0.310 mW/g; SAR(10 g) = 0.199 mW/g

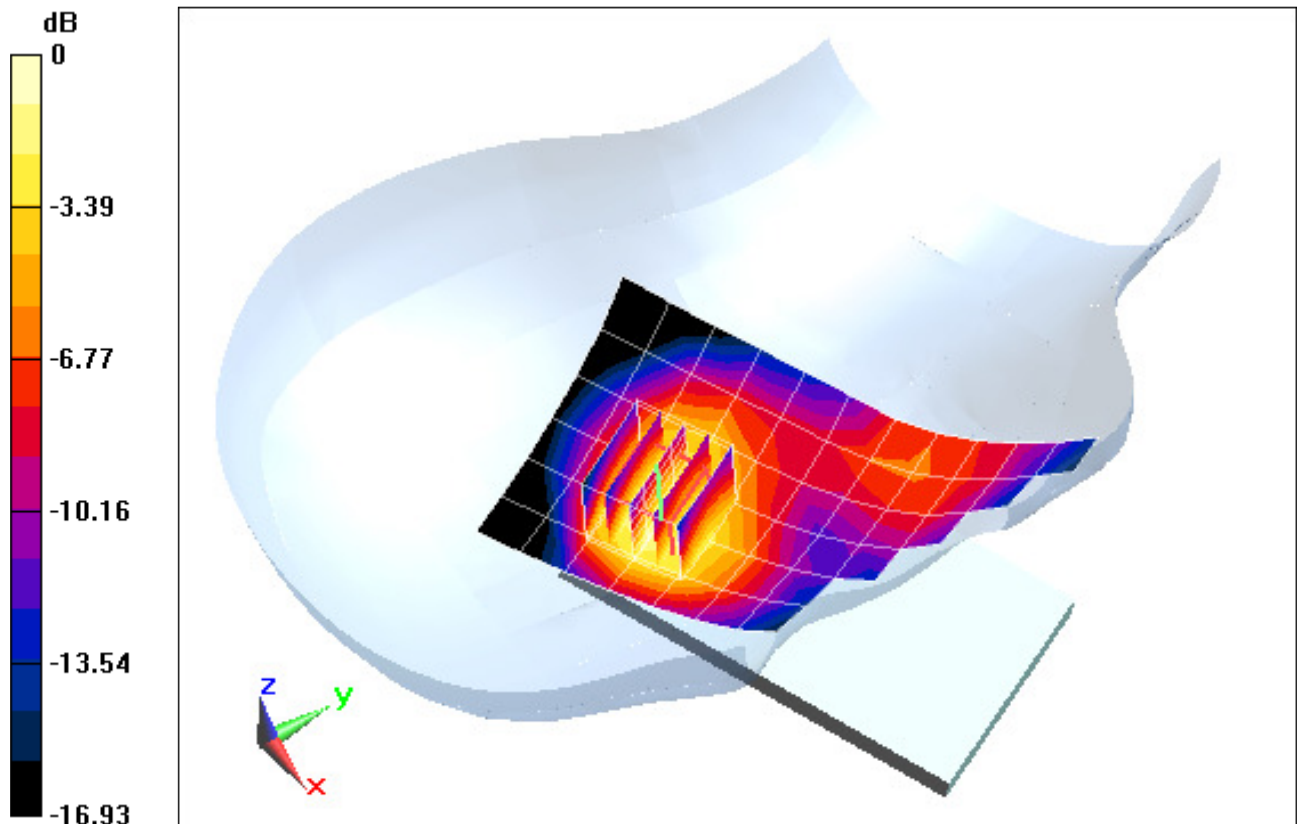

0 dB = 0.324 mW/g = -9.79 dB mW/g

PCTEST ENGINEERING LABORATORY, INC.

DUT: ZNFE970; Type: Portable Handset; Serial: LTE SAR#1

Communication System: LTE RF; Frequency: 1715 MHz; Duty Cycle: 1:1

Medium: 1750 Head Medium parameters used (interpolated):

$f = 1715 \text{ MHz}$; $\sigma = 1.359 \text{ mho/m}$; $\epsilon_r = 39.038$; $\rho = 1000 \text{ kg/m}^3$

Phantom section: Left Section

Test Date: 07-06-2012; Ambient Temp: 23.9°C; Tissue Temp: 23.1°C

Probe: ES3DV2 - SN3022; ConvF(5.2, 5.2, 5.2); Calibrated: 8/25/2011;

Sensor-Surface: 4mm (Mechanical Surface Detection)

Electronics: DAE4 Sn665; Calibrated: 4/19/2012

Phantom: SAM with CRP; Type: SAM; Serial: TP1375

Measurement SW: DASY4, Version 4.7 (80); SEMCAD X Version 14.6.5 (6469)

Mode: LTE Band 4 (AWS), Left Head, Cheek, Low. Ch
10 MHz Bandwidth, QPSK, 1 RB, 0 RB Offset

Area Scan (7x14x1): Measurement grid: dx=15mm, dy=15mm

Zoom Scan (5x5x7)/Cube 0: Measurement grid: dx=8mm, dy=8mm, dz=5mm

Reference Value = 15.743 V/m; Power Drift = 0.04 dB

Peak SAR (extrapolated) = 0.478 mW/g

SAR(1 g) = 0.329 mW/g; SAR(10 g) = 0.209 mW/g

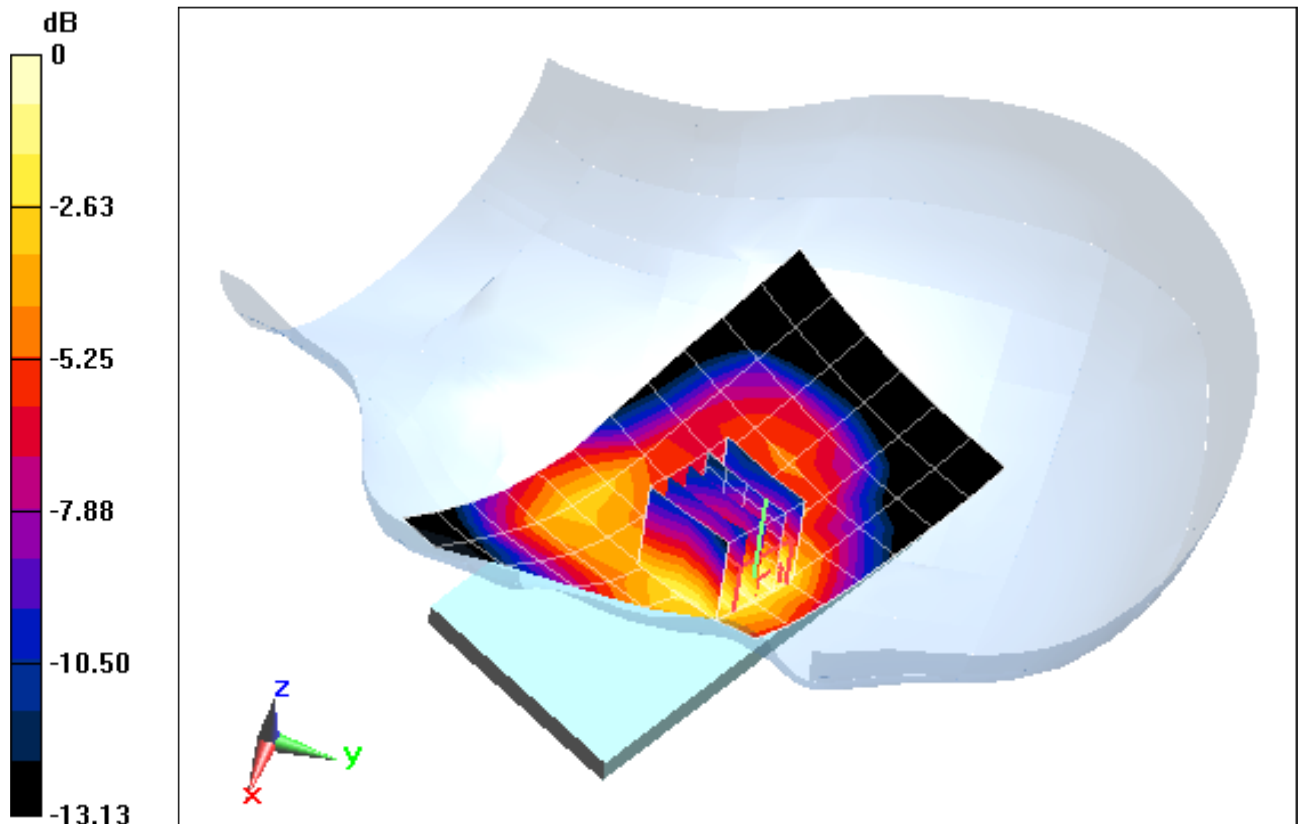

0 dB = 0.358 mW/g = -8.92 dB mW/g

PCTEST ENGINEERING LABORATORY, INC.

DUT: ZNFE970; Type: Portable Handset; Serial: LTE SAR#1

Communication System: LTE RF; Frequency: 1715 MHz; Duty Cycle: 1:1

Medium: 1750 Head Medium parameters used (interpolated):

$f = 1715 \text{ MHz}$; $\sigma = 1.359 \text{ mho/m}$; $\epsilon_r = 39.038$; $\rho = 1000 \text{ kg/m}^3$

Phantom section: Left Section

Test Date: 07-06-2012; Ambient Temp: 23.9°C; Tissue Temp: 23.1°C

Probe: ES3DV2 - SN3022; ConvF(5.2, 5.2, 5.2); Calibrated: 8/25/2011;

Sensor-Surface: 4mm (Mechanical Surface Detection)

Electronics: DAE4 Sn665; Calibrated: 4/19/2012

Phantom: SAM with CRP; Type: SAM; Serial: TP1375

Measurement SW: DASY4, Version 4.7 (80); SEMCAD X Version 14.6.5 (6469)

Mode: LTE Band 4 (AWS), Left Head, Tilt, Low.ch
10 MHz Bandwidth, QPSK, 1 RB, 0 RB Offset

Area Scan (7x14x1): Measurement grid: dx=15mm, dy=15mm

Zoom Scan (5x5x7)/Cube 0: Measurement grid: dx=8mm, dy=8mm, dz=5mm

Reference Value = 14.561 V/m; Power Drift = -0.03 dB

Peak SAR (extrapolated) = 0.390 mW/g

SAR(1 g) = 0.254 mW/g; SAR(10 g) = 0.158 mW/g

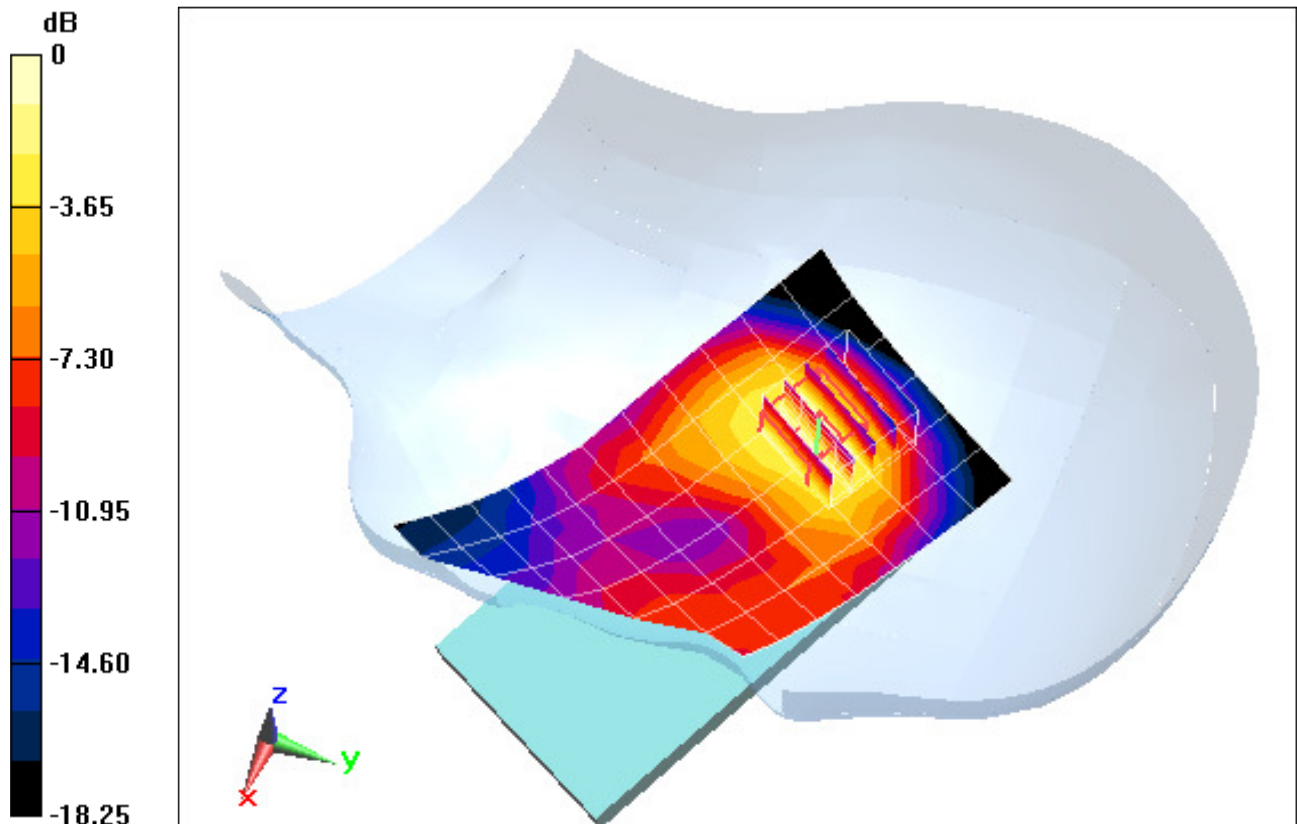

0 dB = 0.269 mW/g = -11.40 dB mW/g

PCTEST ENGINEERING LABORATORY, INC.

DUT: ZNFE970; Type: Portable Handset; Serial: 2G/3G SAR#2

Communication System: GSM1900; Frequency: 1880 MHz; Duty Cycle: 1:8.3

Medium: 1900 Head Medium parameters used:

$f = 1880 \text{ MHz}$; $\sigma = 1.426 \text{ mho/m}$; $\epsilon_r = 38.26$; $\rho = 1000 \text{ kg/m}^3$

Phantom section: Right Section

Test Date: 07-11-2012; Ambient Temp: 24.6°C; Tissue Temp: 23.8°C

Probe: ES3DV3 - SN3209; ConvF(5.15, 5.15, 5.15); Calibrated: 3/16/2012;

Sensor-Surface: 4mm (Mechanical Surface Detection)

Electronics: DAE4 Sn1323; Calibrated: 2/15/2012

Phantom: SAM Main; Type: SAM 4.0; Serial: TP-1114

Measurement SW: DASY4, Version 4.7 (80); SEMCAD X Version 14.6.5 (6469)

Mode: GSM 1900, Right Head, Cheek, Mid.ch

Area Scan (9x13x1): Measurement grid: dx=15mm, dy=15mm

Zoom Scan (5x5x7)/Cube 0: Measurement grid: dx=8mm, dy=8mm, dz=5mm

Reference Value = 12.435 V/m; Power Drift = -0.03 dB

Peak SAR (extrapolated) = 0.313 mW/g

SAR(1 g) = 0.211 mW/g; SAR(10 g) = 0.136 mW/g

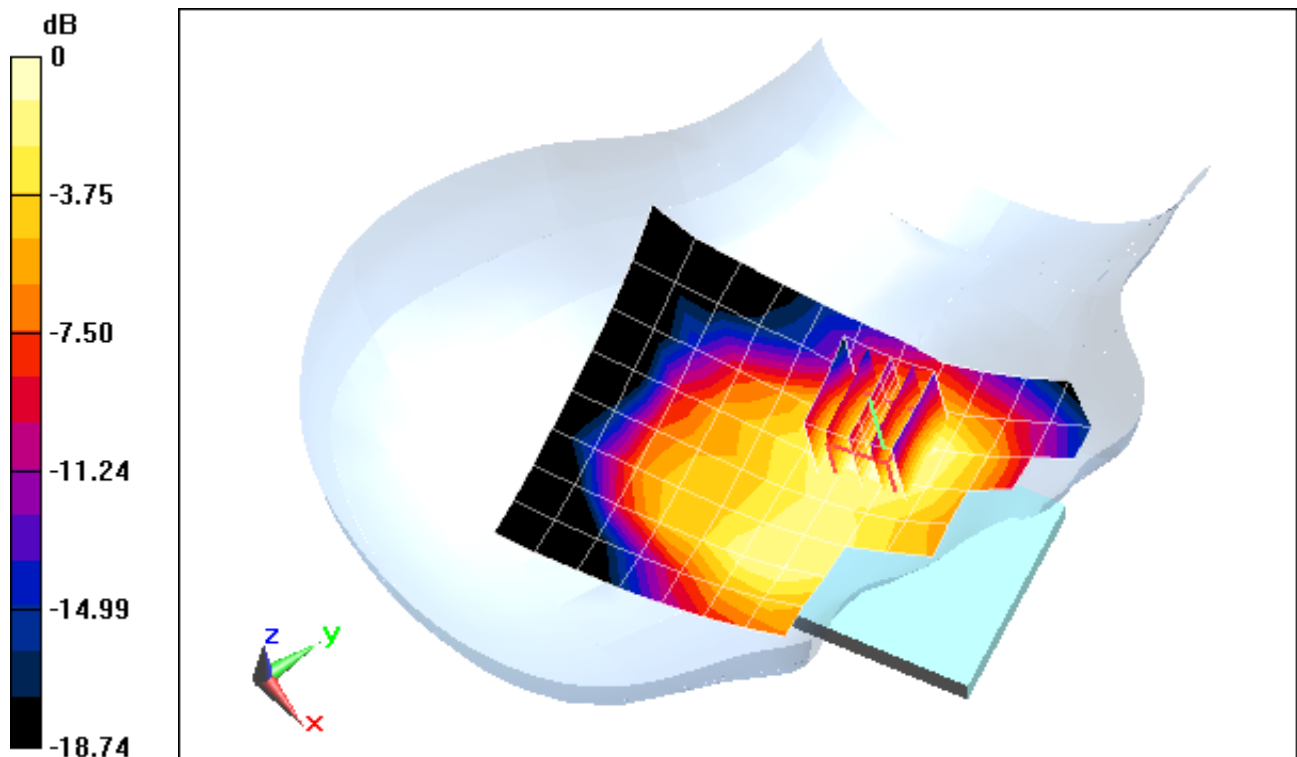

0 dB = 0.229 mW/g = -12.80 dB mW/g

PCTEST ENGINEERING LABORATORY, INC.

DUT: ZNFE970; Type: Portable Handset; Serial: 2G/3G SAR#2

Communication System: GSM1900; Frequency: 1880 MHz; Duty Cycle: 1:8.3

Medium: 1900 Head Medium parameters used:

$f = 1880 \text{ MHz}$; $\sigma = 1.426 \text{ mho/m}$; $\epsilon_r = 38.26$; $\rho = 1000 \text{ kg/m}^3$

Phantom section: Right Section

Test Date: 07-11-2012; Ambient Temp: 24.6°C; Tissue Temp: 23.8°C

Probe: ES3DV3 - SN3209; ConvF(5.15, 5.15, 5.15); Calibrated: 3/16/2012;

Sensor-Surface: 4mm (Mechanical Surface Detection)

Electronics: DAE4 Sn1323; Calibrated: 2/15/2012

Phantom: SAM Main; Type: SAM 4.0; Serial: TP-1114

Measurement SW: DASY4, Version 4.7 (80); SEMCAD X Version 14.6.5 (6469)

Mode: GSM 1900, Right Head, Tilt, Mid.ch

Area Scan (9x13x1): Measurement grid: dx=15mm, dy=15mm

Zoom Scan (5x5x7)/Cube 0: Measurement grid: dx=8mm, dy=8mm, dz=5mm

Reference Value = 3.465 V/m; Power Drift = 0.13 dB

Peak SAR (extrapolated) = 0.223 mW/g

SAR(1 g) = 0.139 mW/g; SAR(10 g) = 0.081 mW/g

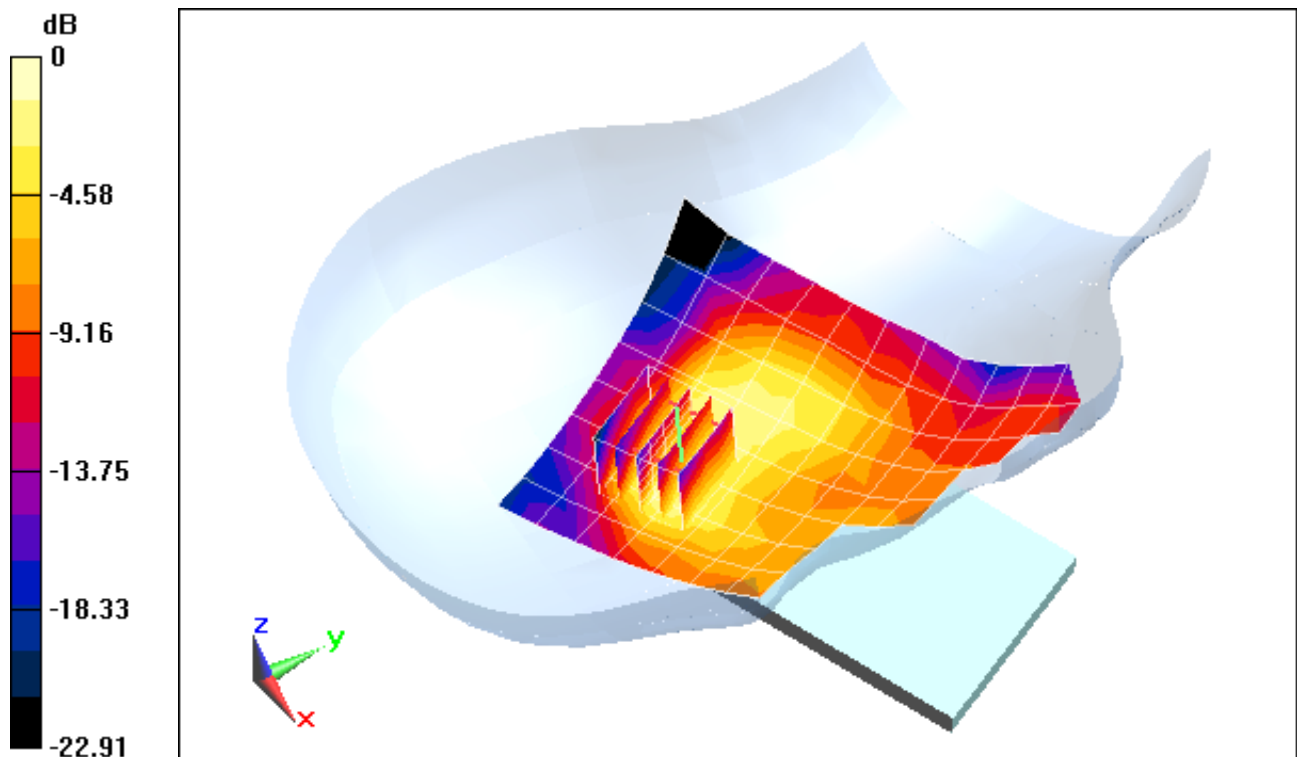

0 dB = 0.150 mW/g = -16.48 dB mW/g

PCTEST ENGINEERING LABORATORY, INC.

DUT: ZNFE970; Type: Portable Handset; Serial: 2G/3G SAR#2

Communication System: GSM1900; Frequency: 1880 MHz; Duty Cycle: 1:8.3

Medium: 1900 Head Medium parameters used:

$f = 1880 \text{ MHz}$; $\sigma = 1.426 \text{ mho/m}$; $\epsilon_r = 38.26$; $\rho = 1000 \text{ kg/m}^3$

Phantom section: Left Section

Test Date: 07-11-2012; Ambient Temp: 24.6°C; Tissue Temp: 23.8°C

Probe: ES3DV3 - SN3209; ConvF(5.15, 5.15, 5.15); Calibrated: 3/16/2012;

Sensor-Surface: 4mm (Mechanical Surface Detection)

Electronics: DAE4 Sn1323; Calibrated: 2/15/2012

Phantom: SAM Main; Type: SAM 4.0; Serial: TP-1114

Measurement SW: DASY4, Version 4.7 (80); SEMCAD X Version 14.6.5 (6469)

Mode: GSM 1900, Left Head, Cheek, Mid.ch

Area Scan (9x13x1): Measurement grid: dx=15mm, dy=15mm

Zoom Scan (5x5x7)/Cube 0: Measurement grid: dx=8mm, dy=8mm, dz=5mm

Reference Value = 16.958 V/m; Power Drift = -0.13 dB

Peak SAR (extrapolated) = 0.587 mW/g

SAR(1 g) = 0.370 mW/g; SAR(10 g) = 0.229 mW/g

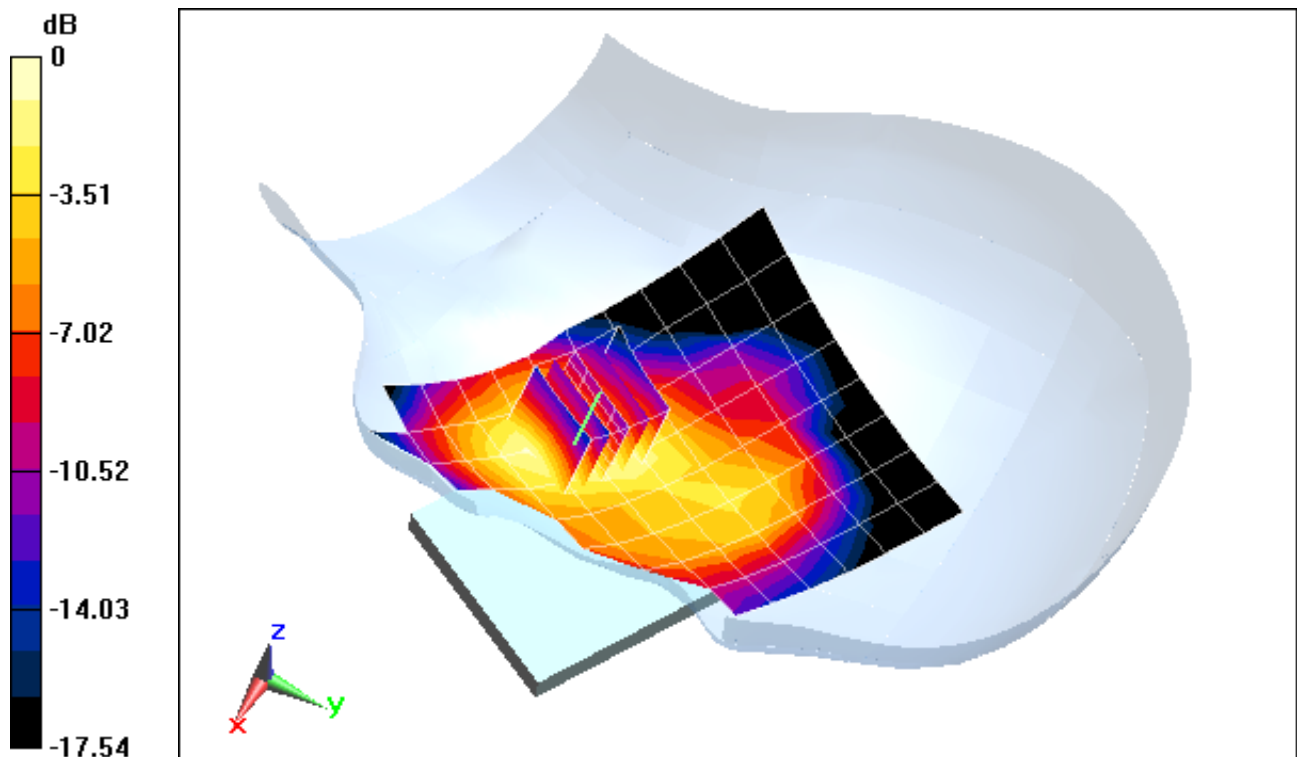

0 dB = 0.401 mW/g = -7.94 dB mW/g

PCTEST ENGINEERING LABORATORY, INC.

DUT: ZNFE970; Type: Portable Handset; Serial: 2G/3G SAR#2

Communication System: GSM1900; Frequency: 1880 MHz; Duty Cycle: 1:8.3

Medium: 1900 Head Medium parameters used:

$f = 1880 \text{ MHz}$; $\sigma = 1.426 \text{ mho/m}$; $\epsilon_r = 38.26$; $\rho = 1000 \text{ kg/m}^3$

Phantom section: Left Section

Test Date: 07-11-2012; Ambient Temp: 24.6°C; Tissue Temp: 23.8°C

Probe: ES3DV3 - SN3209; ConvF(5.15, 5.15, 5.15); Calibrated: 3/16/2012;

Sensor-Surface: 4mm (Mechanical Surface Detection)

Electronics: DAE4 Sn1323; Calibrated: 2/15/2012

Phantom: SAM Main; Type: SAM 4.0; Serial: TP-1114

Measurement SW: DASY4, Version 4.7 (80); SEMCAD X Version 14.6.5 (6469)

Mode: GSM 1900, Left Head, Tilt, Mid.ch

Area Scan (9x13x1): Measurement grid: dx=15mm, dy=15mm

Zoom Scan (5x5x7)/Cube 0: Measurement grid: dx=8mm, dy=8mm, dz=5mm

Reference Value = 10.777 V/m; Power Drift = 0.09 dB

Peak SAR (extrapolated) = 0.243 mW/g

SAR(1 g) = 0.159 mW/g; SAR(10 g) = 0.102 mW/g

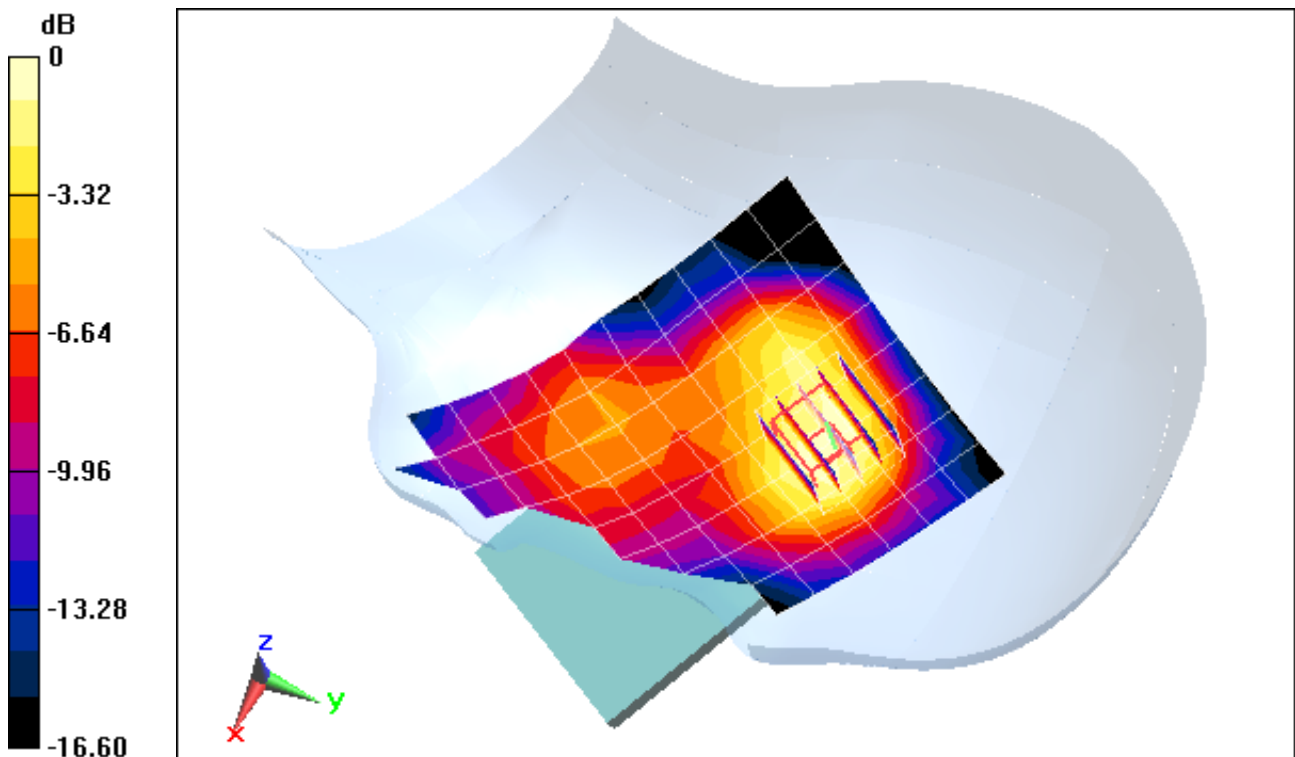

0 dB = 0.172 mW/g = -15.29 dB mW/g

PCTEST ENGINEERING LABORATORY, INC.

DUT: ZNFE970; Type: Portable Handset; Serial: 2G/3G, SAR#2

Communication System: GSM GPRS; 2 Tx slots; Frequency: 1880 MHz; Duty Cycle: 1:4.15

Medium: 1900 Head Medium parameters used:

$f = 1880 \text{ MHz}$; $\sigma = 1.419 \text{ mho/m}$; $\epsilon_r = 41$; $\rho = 1000 \text{ kg/m}^3$

Phantom section: Right Section

Test Date: 08-23-2012; Ambient Temp: 23.9°C; Tissue Temp: 22.7°C

Probe: ES3DV3 - SN3287; ConvF(5.06, 5.06, 5.06); Calibrated: 2/7/2012;

Sensor-Surface: 4mm (Mechanical Surface Detection)

Electronics: DAE4 Sn649; Calibrated: 2/20/2012

Phantom: SAM v5.0 front; Type: QD000P40CD; Serial: TP-1646

Measurement SW: DASY52, Version 52.8 (1); SEMCAD X Version 14.6.5 (6469)

Mode: GPRS 1900, Right Head, Cheek, Mid.ch, 2 Tx slots

Area Scan (8x13x1): Measurement grid: dx=15mm, dy=15mm

Zoom Scan (5x5x7)/Cube 0: Measurement grid: dx=8mm, dy=8mm, dz=5mm

Reference Value = 14.433 V/m; Power Drift = 0.15 dB

Peak SAR (extrapolated) = 0.436 mW/g

SAR(1 g) = 0.287 mW/g; SAR(10 g) = 0.179 mW/g

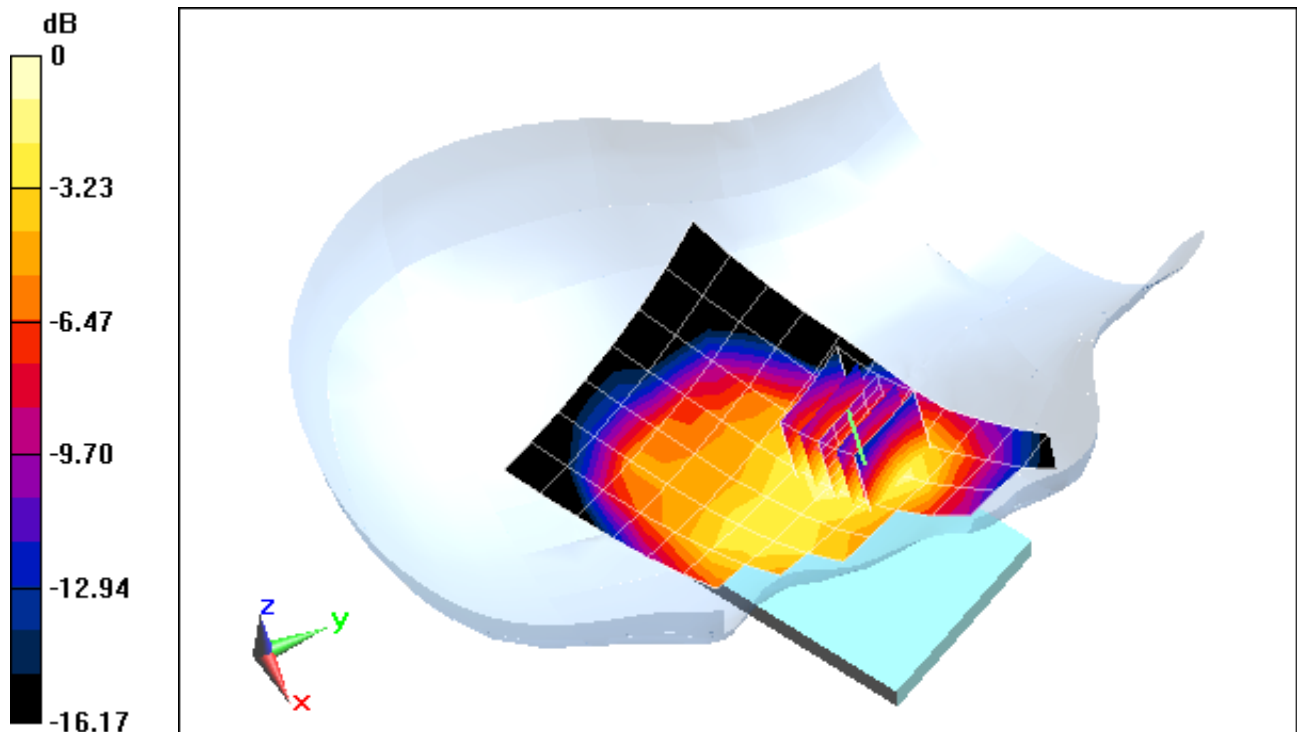

0 dB = 0.311 mW/g = -10.14 dB mW/g

PCTEST ENGINEERING LABORATORY, INC.

DUT: ZNFE970; Type: Portable Handset; Serial: 2G/3G, SAR#2

Communication System: GSM GPRS; 2 Tx slots; Frequency: 1880 MHz; Duty Cycle: 1:4.15

Medium: 1900 Head Medium parameters used:

$$f = 1880 \text{ MHz}; \sigma = 1.419 \text{ mho/m}; \epsilon_r = 41; \rho = 1000 \text{ kg/m}^3$$

Phantom section: Right Section

Test Date: 08-23-2012; Ambient Temp: 23.9°C; Tissue Temp: 22.7°C

Probe: ES3DV3 - SN3287; ConvF(5.06, 5.06, 5.06); Calibrated: 2/7/2012;

Sensor-Surface: 4mm (Mechanical Surface Detection)

Electronics: DAE4 Sn649; Calibrated: 2/20/2012

Phantom: SAM v5.0 front; Type: QD000P40CD; Serial: TP-1646

Measurement SW: DASY52, Version 52.8 (1); SEMCAD X Version 14.6.5 (6469)

Mode: GPRS 1900, Right Head, Tilt, Mid.ch, 2 Tx slots

Area Scan (8x13x1): Measurement grid: dx=15mm, dy=15mm

Zoom Scan (5x5x7)/Cube 0: Measurement grid: dx=8mm, dy=8mm, dz=5mm

Reference Value = 10.258 V/m; Power Drift = -0.05 dB

Peak SAR (extrapolated) = 0.252 mW/g

SAR(1 g) = 0.157 mW/g; SAR(10 g) = 0.094 mW/g

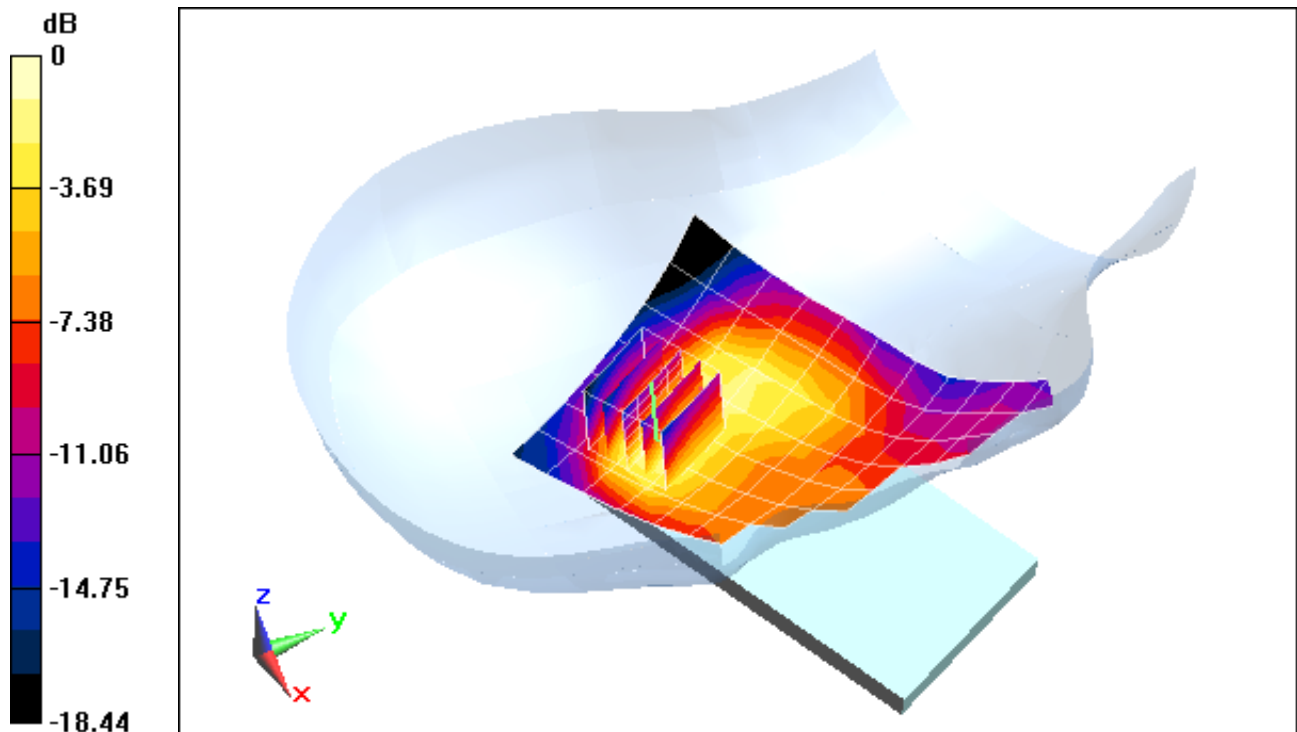

0 dB = 0.175 mW/g = -15.14 dB mW/g

PCTEST ENGINEERING LABORATORY, INC.

DUT: ZNFE970; Type: Portable Handset; Serial: 2G/3G, SAR#2

Communication System: GSM GPRS; 2 Tx slots; Frequency: 1880 MHz; Duty Cycle: 1:4.15

Medium: 1900 Head Medium parameters used:

$$f = 1880 \text{ MHz}; \sigma = 1.419 \text{ mho/m}; \epsilon_r = 41; \rho = 1000 \text{ kg/m}^3$$

Phantom section: Left Section

Test Date: 08-23-2012; Ambient Temp: 23.9°C; Tissue Temp: 22.7°C

Probe: ES3DV3 - SN3287; ConvF(5.06, 5.06, 5.06); Calibrated: 2/7/2012;

Sensor-Surface: 4mm (Mechanical Surface Detection)

Electronics: DAE4 Sn649; Calibrated: 2/20/2012

Phantom: SAM v5.0 front; Type: QD000P40CD; Serial: TP-1646

Measurement SW: DASY52, Version 52.8 (1); SEMCAD X Version 14.6.5 (6469)

Mode: GPRS 1900, Left Head, Cheek, Mid.ch, 2 Tx slots

Area Scan (8x13x1): Measurement grid: dx=15mm, dy=15mm

Zoom Scan (5x5x7)/Cube 0: Measurement grid: dx=8mm, dy=8mm, dz=5mm

Reference Value = 18.525 V/m; Power Drift = 0.04 dB

Peak SAR (extrapolated) = 0.703 mW/g

SAR(1 g) = 0.452 mW/g; SAR(10 g) = 0.281 mW/g

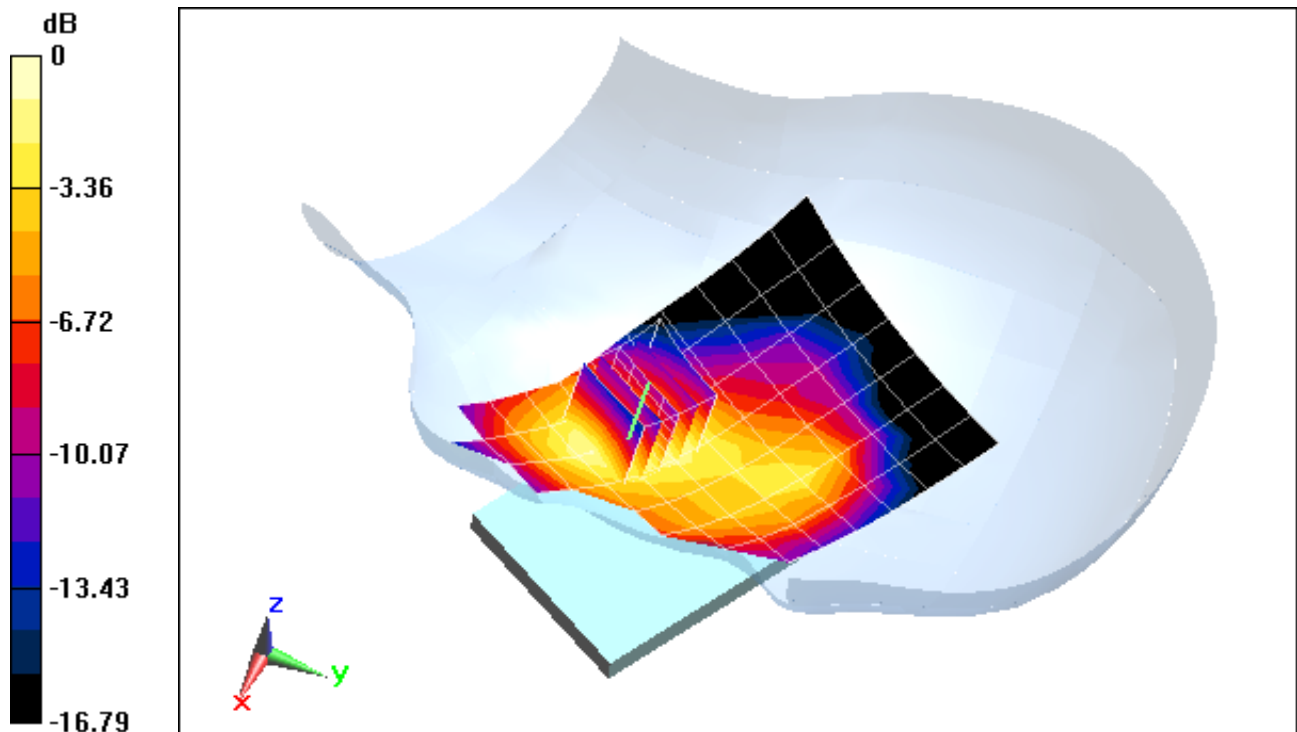

0 dB = 0.487 mW/g = -6.25 dB mW/g

PCTEST ENGINEERING LABORATORY, INC.

DUT: ZNFE970; Type: Portable Handset; Serial: 2G/3G, SAR#2

Communication System: GSM GPRS; 2 Tx slots; Frequency: 1880 MHz; Duty Cycle: 1:4.15

Medium: 1900 Head Medium parameters used:

$$f = 1880 \text{ MHz}; \sigma = 1.419 \text{ mho/m}; \epsilon_r = 41; \rho = 1000 \text{ kg/m}^3$$

Phantom section: Left Section

Test Date: 08-23-2012; Ambient Temp: 23.9°C; Tissue Temp: 22.7°C

Probe: ES3DV3 - SN3287; ConvF(5.06, 5.06, 5.06); Calibrated: 2/7/2012;

Sensor-Surface: 4mm (Mechanical Surface Detection)

Electronics: DAE4 Sn649; Calibrated: 2/20/2012

Phantom: SAM v5.0 front; Type: QD000P40CD; Serial: TP-1646

Measurement SW: DASY52, Version 52.8 (1); SEMCAD X Version 14.6.5 (6469)

Mode: GPRS 1900, Left Head, Tilt, Mid.ch, 2 Tx slots

Area Scan (8x13x1): Measurement grid: dx=15mm, dy=15mm

Zoom Scan (5x5x7)/Cube 0: Measurement grid: dx=8mm, dy=8mm, dz=5mm

Reference Value = 11.859 V/m; Power Drift = -0.01 dB

Peak SAR (extrapolated) = 0.272 mW/g

SAR(1 g) = 0.184 mW/g; SAR(10 g) = 0.117 mW/g

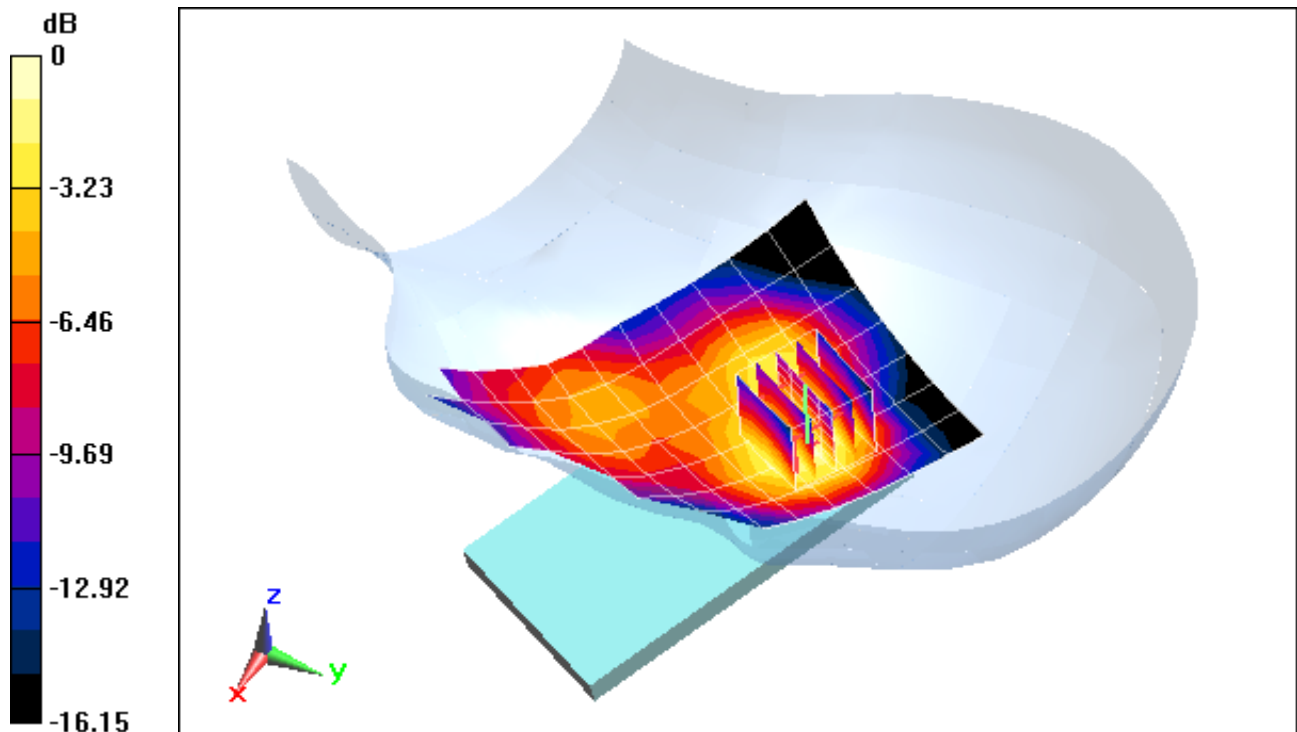

0 dB = 0.201 mW/g = -13.94 dB mW/g

PCTEST ENGINEERING LABORATORY, INC.

DUT: ZNFE970; Type: Portable Handset; Serial: 2G/3G SAR #2

Communication System: WCDMA1900; Frequency: 1880 MHz; Duty Cycle: 1:1
Medium: 1900 Head Medium parameters used:

$f = 1880 \text{ MHz}$; $\sigma = 1.426 \text{ mho/m}$; $\epsilon_r = 38.26$; $\rho = 1000 \text{ kg/m}^3$

Phantom section: Right Section

Test Date: 07-11-2012; Ambient Temp: 24.6°C; Tissue Temp: 23.8°C

Probe: ES3DV3 - SN3209; ConvF(5.15, 5.15, 5.15); Calibrated: 3/16/2012;

Sensor-Surface: 4mm (Mechanical Surface Detection)

Electronics: DAE4 Sn1323; Calibrated: 2/15/2012

Phantom: SAM Main; Type: SAM 4.0; Serial: TP-1114

Measurement SW: DASY4, Version 4.7 (80); SEMCAD X Version 14.6.5 (6469)

Mode: WCDMA 1900, Right Head, Cheek, Mid.ch

Area Scan (9x13x1): Measurement grid: dx=15mm, dy=15mm

Zoom Scan (5x5x7)/Cube 0: Measurement grid: dx=8mm, dy=8mm, dz=5mm

Reference Value = 14.990 V/m; Power Drift = -0.02 dB

Peak SAR (extrapolated) = 0.457 mW/g

SAR(1 g) = 0.303 mW/g; SAR(10 g) = 0.190 mW/g

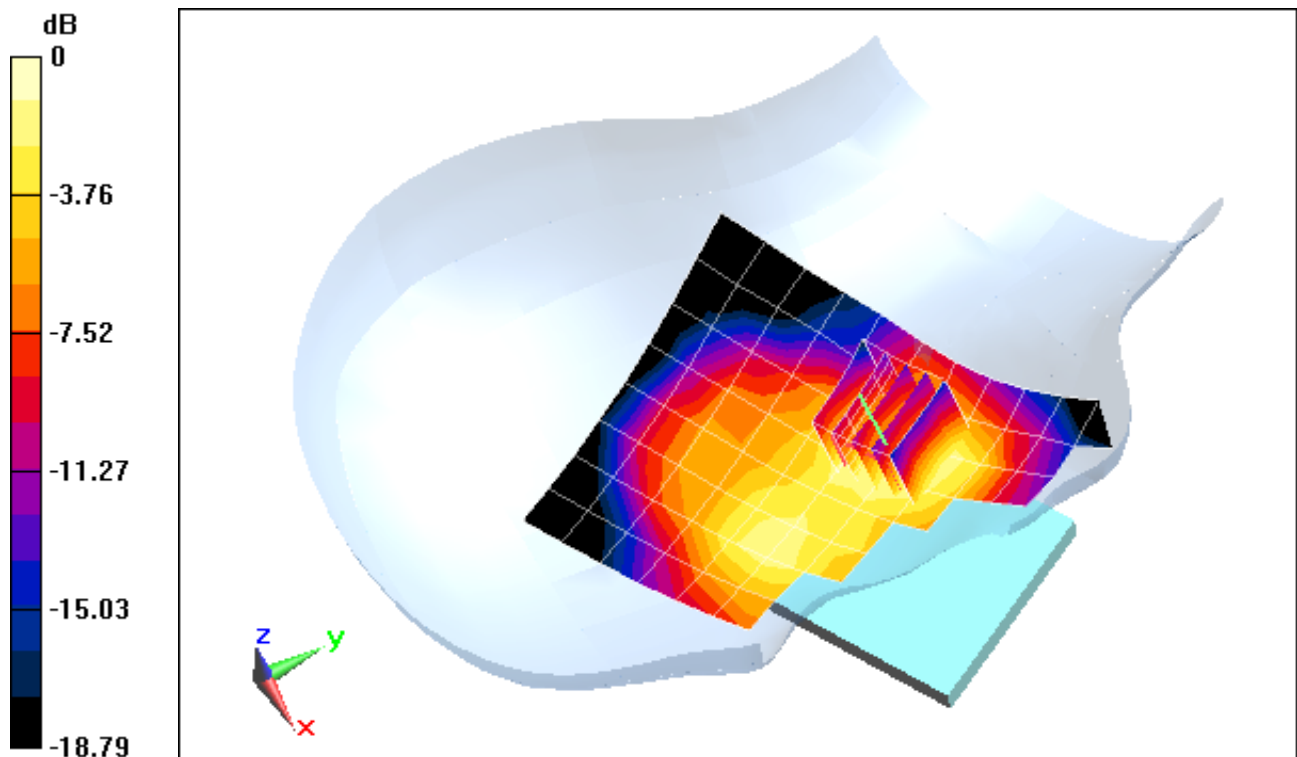

0 dB = 0.325 mW/g = -9.76 dB mW/g

PCTEST ENGINEERING LABORATORY, INC.

DUT: ZNFE970; Type: Portable Handset; Serial: 2G/3G SAR #2

Communication System: WCDMA1900; Frequency: 1880 MHz; Duty Cycle: 1:1
Medium: 1900 Head Medium parameters used:

$f = 1880 \text{ MHz}$; $\sigma = 1.426 \text{ mho/m}$; $\epsilon_r = 38.26$; $\rho = 1000 \text{ kg/m}^3$

Phantom section: Right Section

Test Date: 07-11-2012; Ambient Temp: 24.6°C; Tissue Temp: 23.8°C

Probe: ES3DV3 - SN3209; ConvF(5.15, 5.15, 5.15); Calibrated: 3/16/2012;

Sensor-Surface: 4mm (Mechanical Surface Detection)

Electronics: DAE4 Sn1323; Calibrated: 2/15/2012

Phantom: SAM Main; Type: SAM 4.0; Serial: TP-1114

Measurement SW: DASY4, Version 4.7 (80); SEMCAD X Version 14.6.5 (6469)

Mode: WCDMA 1900, Right Head, Tilt, Mid.ch

Area Scan (9x13x1): Measurement grid: dx=15mm, dy=15mm

Zoom Scan (5x5x7)/Cube 0: Measurement grid: dx=8mm, dy=8mm, dz=5mm

Reference Value = 3.840 V/m; Power Drift = -0.02 dB

Peak SAR (extrapolated) = 0.258 mW/g

SAR(1 g) = 0.161 mW/g; SAR(10 g) = 0.098 mW/g

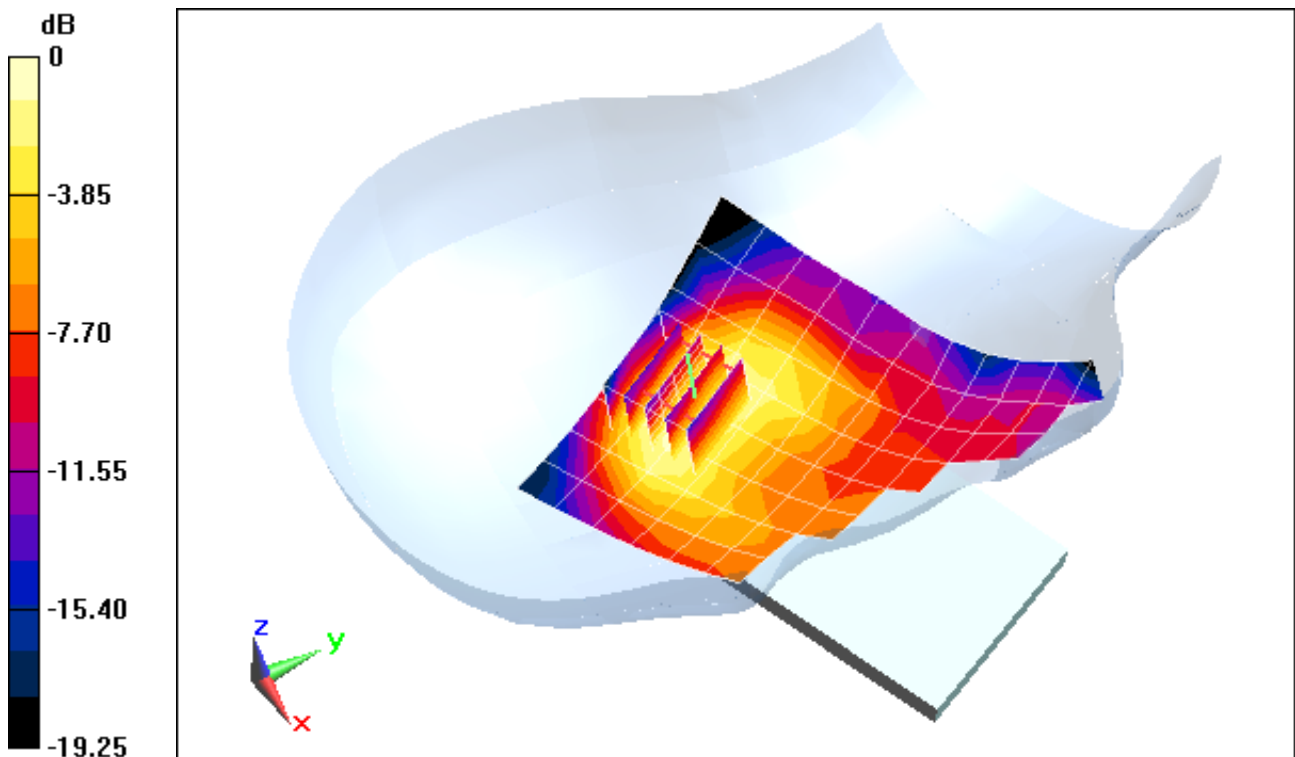

0 dB = 0.172 mW/g = -15.29 dB mW/g

PCTEST ENGINEERING LABORATORY, INC.

DUT: ZNFE970; Type: Portable Handset; Serial: 2G/3G SAR #2

Communication System: WCDMA1900; Frequency: 1880 MHz; Duty Cycle: 1:1

Medium: 1900 Head Medium parameters used:

$f = 1880 \text{ MHz}$; $\sigma = 1.426 \text{ mho/m}$; $\epsilon_r = 38.26$; $\rho = 1000 \text{ kg/m}^3$

Phantom section: Left Section

Test Date: 07-11-2012; Ambient Temp: 24.6°C; Tissue Temp: 23.8°C

Probe: ES3DV3 - SN3209; ConvF(5.15, 5.15, 5.15); Calibrated: 3/16/2012;

Sensor-Surface: 4mm (Mechanical Surface Detection)

Electronics: DAE4 Sn1323; Calibrated: 2/15/2012

Phantom: SAM Main; Type: SAM 4.0; Serial: TP-1114

Measurement SW: DASY4, Version 4.7 (80); SEMCAD X Version 14.6.5 (6469)

Mode: WCDMA 1900, Left Head, Cheek, Mid.ch

Area Scan (9x13x1): Measurement grid: dx=15mm, dy=15mm

Zoom Scan (5x5x7)/Cube 0: Measurement grid: dx=8mm, dy=8mm, dz=5mm

Reference Value = 18.997 V/m; Power Drift = -0.12 dB

Peak SAR (extrapolated) = 0.722 mW/g

SAR(1 g) = 0.460 mW/g; SAR(10 g) = 0.285 mW/g

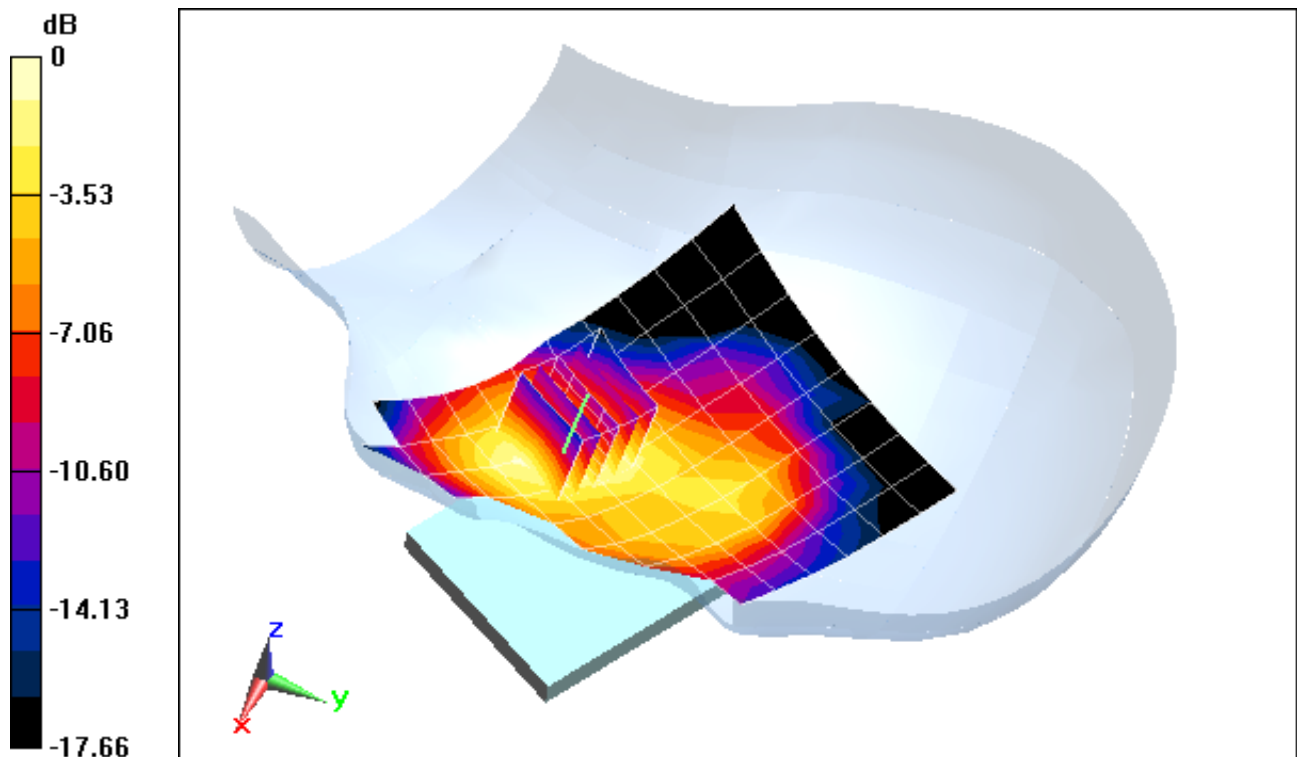

0 dB = 0.495 mW/g = -6.11 dB mW/g

PCTEST ENGINEERING LABORATORY, INC.

DUT: ZNFE970; Type: Portable Handset; Serial: 2G/3G SAR #2

Communication System: WCDMA1900; Frequency: 1880 MHz; Duty Cycle: 1:1
Medium: 1900 Head Medium parameters used:

$f = 1880 \text{ MHz}$; $\sigma = 1.426 \text{ mho/m}$; $\epsilon_r = 38.26$; $\rho = 1000 \text{ kg/m}^3$

Phantom section: Left Section

Test Date: 07-11-2012; Ambient Temp: 24.6°C; Tissue Temp: 23.8°C

Probe: ES3DV3 - SN3209; ConvF(5.15, 5.15, 5.15); Calibrated: 3/16/2012;

Sensor-Surface: 4mm (Mechanical Surface Detection)

Electronics: DAE4 Sn1323; Calibrated: 2/15/2012

Phantom: SAM Main; Type: SAM 4.0; Serial: TP-1114

Measurement SW: DASY4, Version 4.7 (80); SEMCAD X Version 14.6.5 (6469)

Mode: WCDMA 1900, Left Head, Tilt, Mid.ch

Area Scan (7x10x1): Measurement grid: dx=15mm, dy=15mm

Zoom Scan (5x5x7)/Cube 0: Measurement grid: dx=8mm, dy=8mm, dz=5mm

Reference Value = 12.023 V/m; Power Drift = 0.03 dB

Peak SAR (extrapolated) = 0.284 mW/g

SAR(1 g) = 0.189 mW/g; SAR(10 g) = 0.123 mW/g

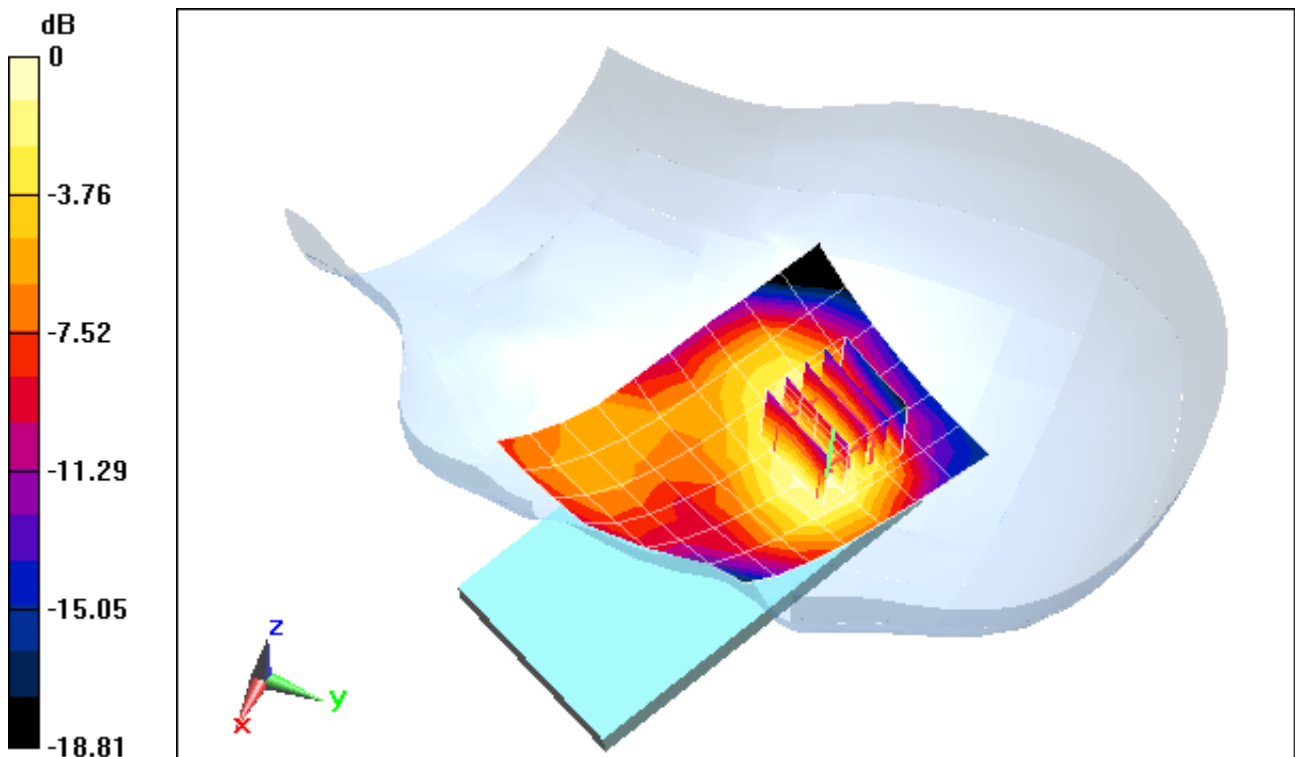

0 dB = 0.201 mW/g = -13.94 dB mW/g

PCTEST ENGINEERING LABORATORY, INC.

DUT: ZNFE970; Type: Portable Handset; Serial: LTE SAR #3

Communication System: LTE PCS 10 Mhz; Frequency: 1855 MHz; Duty Cycle: 1:1

Medium: 1900 Head Medium parameters used (interpolated):

$f = 1855 \text{ MHz}$; $\sigma = 1.399 \text{ mho/m}$; $\epsilon_r = 38.368$; $\rho = 1000 \text{ kg/m}^3$

Phantom section: Right Section

Test Date: 07-11-2012; Ambient Temp: 24.6°C; Tissue Temp: 23.8°C

Probe: ES3DV3 - SN3209; ConvF(5.15, 5.15, 5.15); Calibrated: 3/16/2012;

Sensor-Surface: 4mm (Mechanical Surface Detection)

Electronics: DAE4 Sn1323; Calibrated: 2/15/2012

Phantom: SAM Main; Type: SAM 4.0; Serial: TP-1114

Measurement SW: DASY4, Version 4.7 (80); SEMCAD X Version 14.6.5 (6469)

Mode: LTE Band 2 (PCS), Right Head, Cheek, Low.ch
10 MHz Bandwidth, QPSK, 1 RB, 49 RB Offset

Area Scan (9x13x1): Measurement grid: dx=15mm, dy=15mm

Zoom Scan (5x5x7)/Cube 0: Measurement grid: dx=8mm, dy=8mm, dz=5mm

Reference Value = 14.807 V/m; Power Drift = -0.02 dB

Peak SAR (extrapolated) = 0.431 mW/g

SAR(1 g) = 0.285 mW/g; SAR(10 g) = 0.186 mW/g

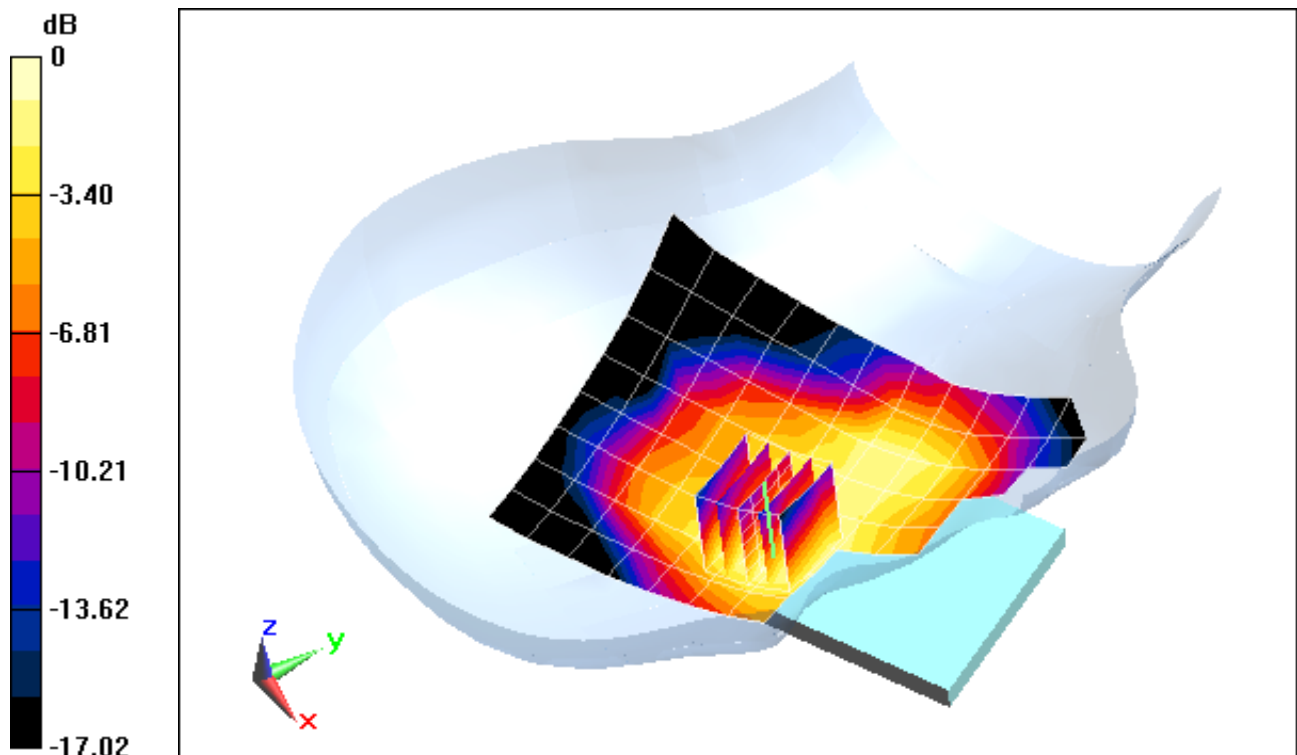

0 dB = 0.305 mW/g = -10.31 dB mW/g

PCTEST ENGINEERING LABORATORY, INC.

DUT: ZNFE970; Type: Portable Handset; Serial: LTE SAR #3

Communication System: LTE PCS 10 Mhz; Frequency: 1905 MHz; Duty Cycle: 1:1

Medium: 1900 Head Medium parameters used (interpolated):

$f = 1905 \text{ MHz}$; $\sigma = 1.453 \text{ mho/m}$; $\epsilon_r = 38.152$; $\rho = 1000 \text{ kg/m}^3$

Phantom section: Right Section

Test Date: 07-11-2012; Ambient Temp: 24.6°C; Tissue Temp: 23.8°C

Probe: ES3DV3 - SN3209; ConvF(5.15, 5.15, 5.15); Calibrated: 3/16/2012;

Sensor-Surface: 4mm (Mechanical Surface Detection)

Electronics: DAE4 Sn1323; Calibrated: 2/15/2012

Phantom: SAM Main; Type: SAM 4.0; Serial: TP-1114

Measurement SW: DASY4, Version 4.7 (80); SEMCAD X Version 14.6.5 (6469) |

**Mode: LTE Band 2 (PCS), Right Head, Tilt, High ch
10 MHz Bandwidth, 16QAM, 1 RB, 0 RB Offset**

Area Scan (8x12x1): Measurement grid: dx=15mm, dy=15mm

Zoom Scan (5x5x7)/Cube 0: Measurement grid: dx=8mm, dy=8mm, dz=5mm

Reference Value = 12.546 V/m; Power Drift = 0.06 dB

Peak SAR (extrapolated) = 0.299 mW/g

SAR(1 g) = 0.184 mW/g; SAR(10 g) = 0.111 mW/g

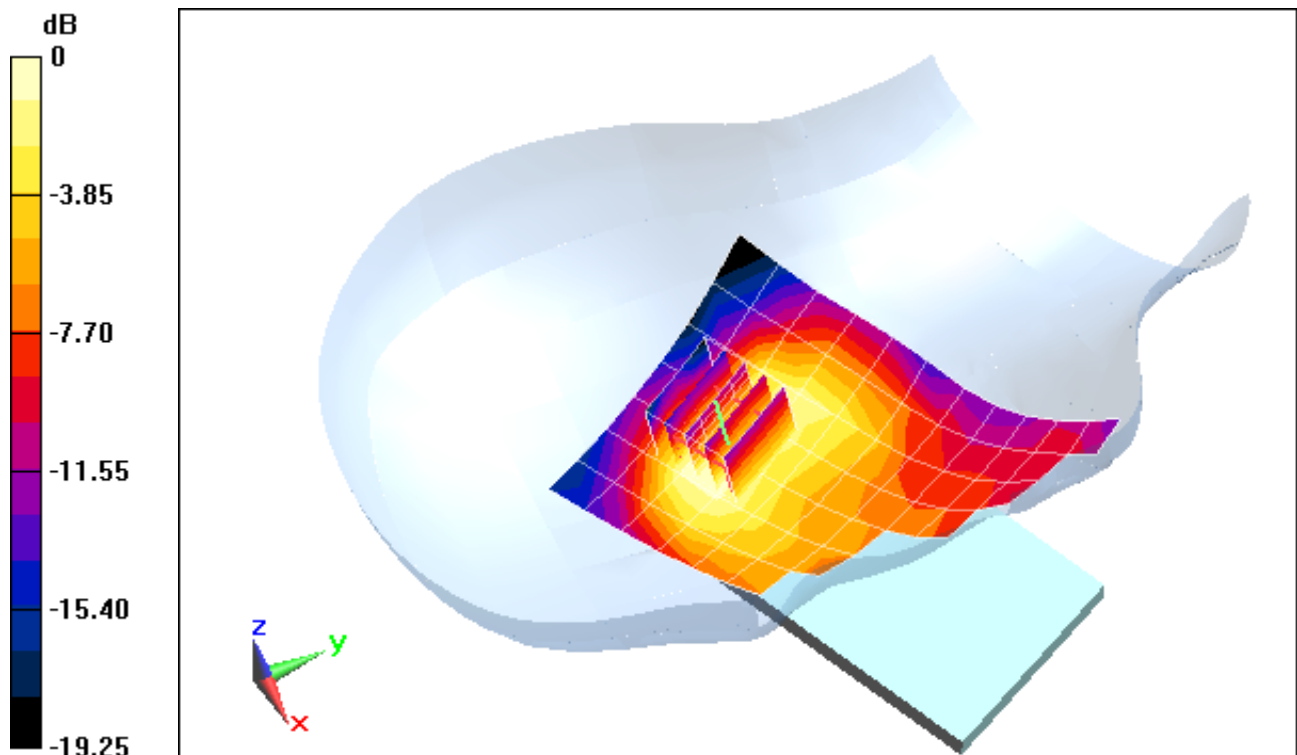

0 dB = 0.201 mW/g = -13.94 dB mW/g

PCTEST ENGINEERING LABORATORY, INC.

DUT: ZNFE970; Type: Portable Handset; Serial: LTE SAR#3

Communication System: LTE PCS 10 Mhz; Frequency: 1855 MHz; Duty Cycle: 1:1

Medium: 1900 Head Medium parameters used (interpolated):

$f = 1855 \text{ MHz}$; $\sigma = 1.399 \text{ mho/m}$; $\epsilon_r = 38.368$; $\rho = 1000 \text{ kg/m}^3$

Phantom section: Left Section

Test Date: 07-11-2012; Ambient Temp: 24.6°C; Tissue Temp: 23.8°C

Probe: ES3DV3 - SN3209; ConvF(5.15, 5.15, 5.15); Calibrated: 3/16/2012;

Sensor-Surface: 4mm (Mechanical Surface Detection)

Electronics: DAE4 Sn1323; Calibrated: 2/15/2012

Phantom: SAM Main; Type: SAM 4.0; Serial: TP-1114

Measurement SW: DASY4, Version 4.7 (80); SEMCAD X Version 14.6.5 (6469)

Mode: LTE Band 2 (PCS), Left Head, Cheek, Low.ch
10 MHz Bandwidth, QPSK, 1 RB, 49 RB Offset

Area Scan (8x12x1): Measurement grid: dx=15mm, dy=15mm

Zoom Scan (5x5x7)/Cube 0: Measurement grid: dx=8mm, dy=8mm, dz=5mm

Reference Value = 22.263 V/m; Power Drift = 0.13 dB

Peak SAR (extrapolated) = 0.978 mW/g

SAR(1 g) = 0.642 mW/g; SAR(10 g) = 0.401 mW/g

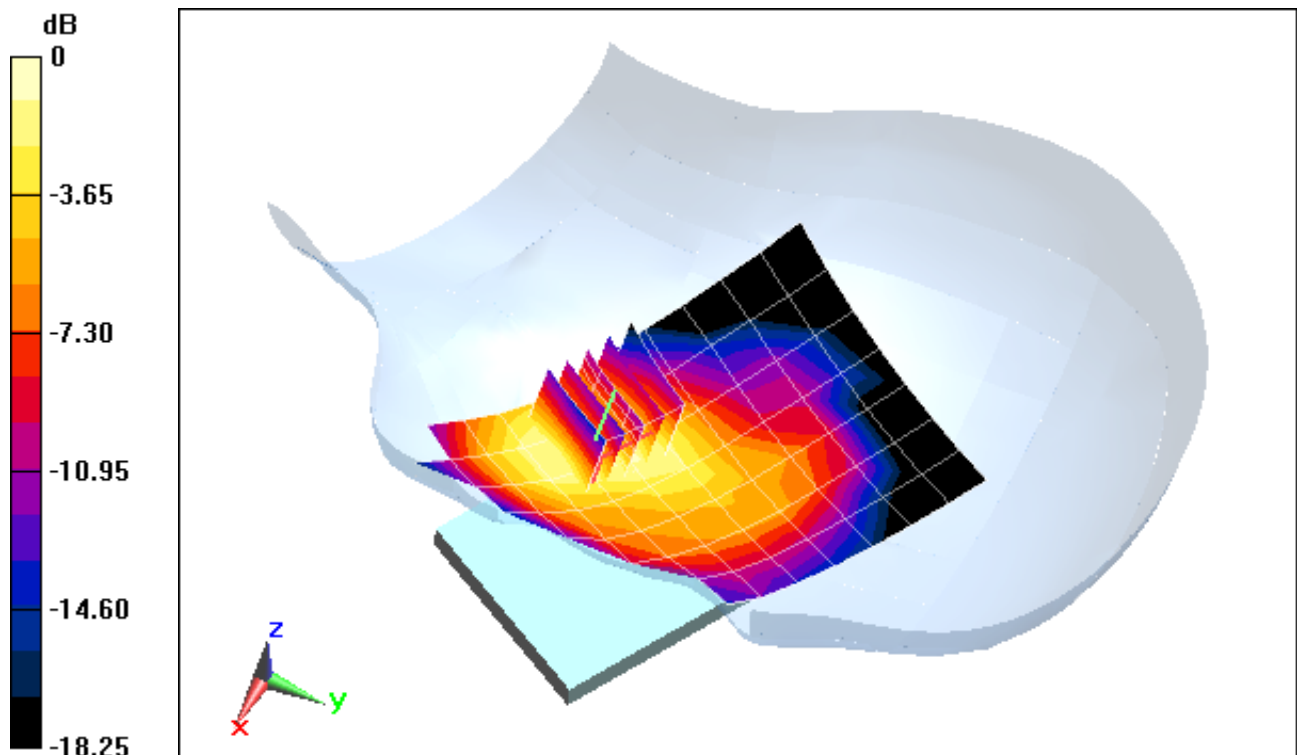

0 dB = 0.693 mW/g = -3.19 dB mW/g

PCTEST ENGINEERING LABORATORY, INC.

DUT: ZNFE970; Type: Portable Handset; Serial: LTE SAR#3

Communication System: LTE PCS 10 Mhz; Frequency: 1855 MHz; Duty Cycle: 1:1

Medium: 1900 Head Medium parameters used (interpolated):

$f = 1855 \text{ MHz}$; $\sigma = 1.399 \text{ mho/m}$; $\epsilon_r = 38.368$; $\rho = 1000 \text{ kg/m}^3$

Phantom section: Left Section

Test Date: 07-11-2012; Ambient Temp: 24.6°C; Tissue Temp: 23.8°C

Probe: ES3DV3 - SN3209; ConvF(5.15, 5.15, 5.15); Calibrated: 3/16/2012;

Sensor-Surface: 4mm (Mechanical Surface Detection)

Electronics: DAE4 Sn1323; Calibrated: 2/15/2012

Phantom: SAM Main; Type: SAM 4.0; Serial: TP-1114

Measurement SW: DASY4, Version 4.7 (80); SEMCAD X Version 14.6.5 (6469)

Mode: LTE Band 2 (PCS), Left Head, Tilt, Low.ch
10 MHz Bandwidth, QPSK, 1 RB, 49 RB Offset

Area Scan (7x14x1): Measurement grid: dx=15mm, dy=15mm

Zoom Scan (5x5x7)/Cube 0: Measurement grid: dx=8mm, dy=8mm, dz=5mm

Reference Value = 13.463 V/m; Power Drift = 0.07 dB

Peak SAR (extrapolated) = 0.302 mW/g

SAR(1 g) = 0.208 mW/g; SAR(10 g) = 0.136 mW/g

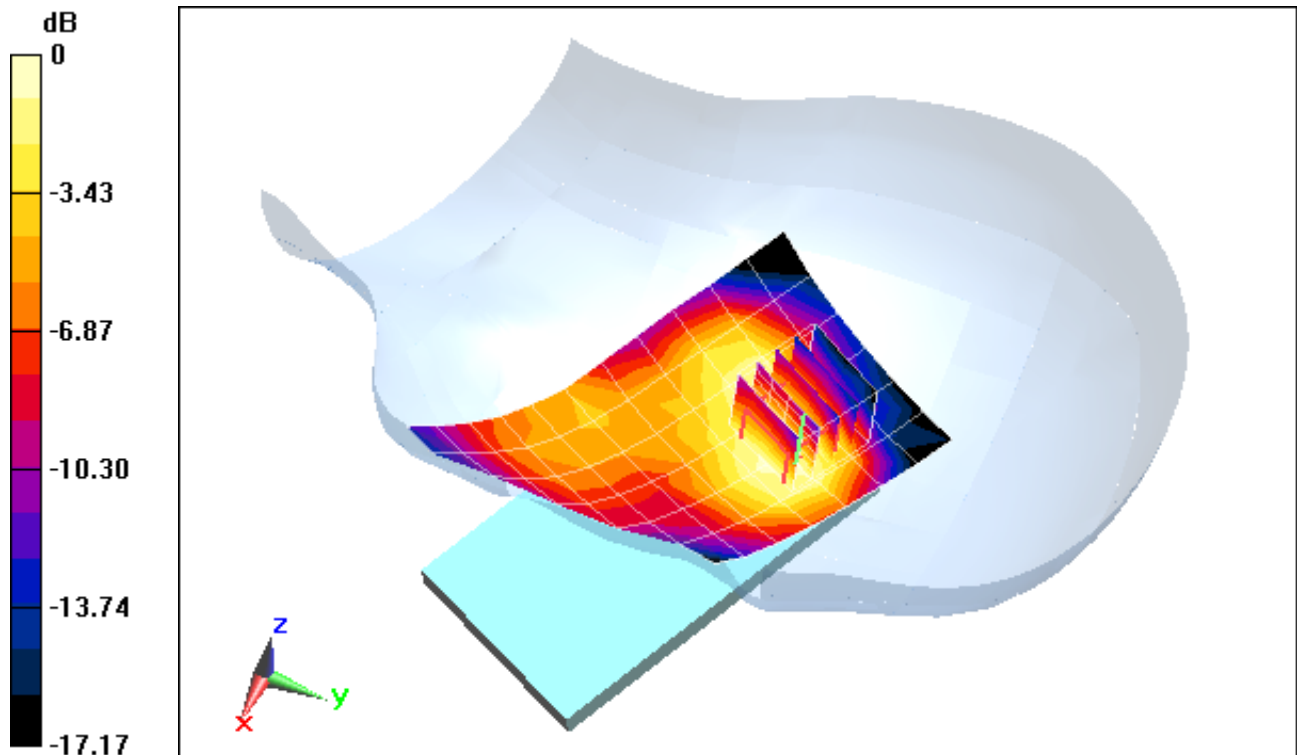

0 dB = 0.221 mW/g = -13.11 dB mW/g

PCTEST ENGINEERING LABORATORY, INC.

DUT: ZNFE970; Type: Portable Handset; Serial: WI-FI SAR #1

Communication System: IEEE 802.11b; Frequency: 2412 MHz; Duty Cycle: 1:1

Medium: 2450 Head Medium parameters used (interpolated):

$f = 2412 \text{ MHz}$; $\sigma = 1.835 \text{ mho/m}$; $\epsilon_r = 39.06$; $\rho = 1000 \text{ kg/m}^3$

Phantom section: Right Section

Test Date: 07-10-2012; Ambient Temp: 24.2°C; Tissue Temp: 24.1°C

Probe: ES3DV3 - SN3209; ConvF(4.46, 4.46, 4.46); Calibrated: 3/16/2012;

Sensor-Surface: 3mm (Mechanical Surface Detection)

Electronics: DAE4 Sn1323; Calibrated: 2/15/2012

Phantom: SAM Main; Type: SAM 4.0; Serial: TP-1114

Measurement SW: DASY4, Version 4.7 (80); SEMCAD X Version 14.6.5 (6469)

Mode: IEEE 802.11b, Right Head, Cheek, Ch 01, 1 Mbps

Area Scan (10x15x1): Measurement grid: dx=12mm, dy=12mm

Zoom Scan (7x7x7)/Cube 0: Measurement grid: dx=5mm, dy=5mm, dz=5mm

Reference Value = 9.219 V/m; Power Drift = -0.07 dB

Peak SAR (extrapolated) = 0.266 mW/g

SAR(1 g) = 0.139 mW/g; SAR(10 g) = 0.072 mW/g

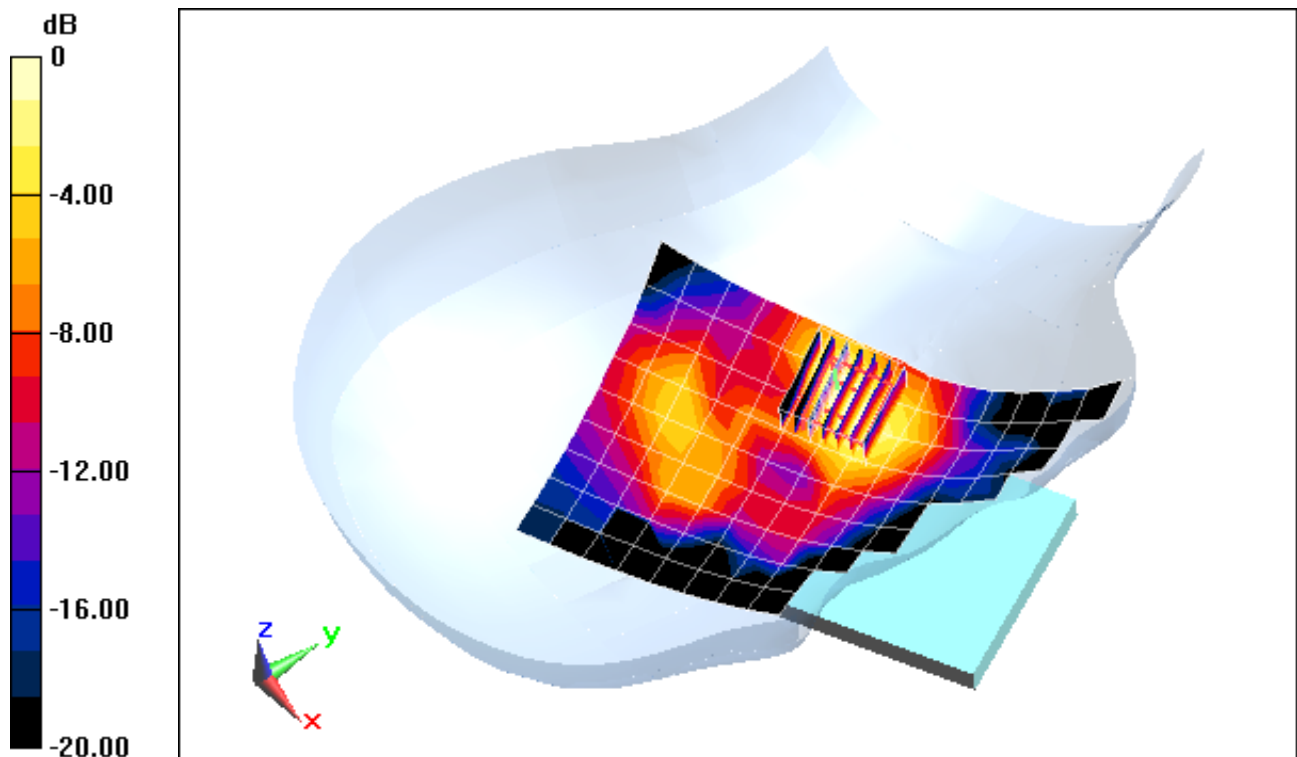

0 dB = 0.173 mW/g = -15.24 dB mW/g

PCTEST ENGINEERING LABORATORY, INC.

DUT: ZNFE970; Type: Portable Handset; Serial: WI-FI SAR #1

Communication System: IEEE 802.11b; Frequency: 2412 MHz; Duty Cycle: 1:1

Medium: 2450 Head Medium parameters used (interpolated):

$f = 2412 \text{ MHz}$; $\sigma = 1.835 \text{ mho/m}$; $\epsilon_r = 39.06$; $\rho = 1000 \text{ kg/m}^3$

Phantom section: Right Section

Test Date: 07-10-2012; Ambient Temp: 24.2°C; Tissue Temp: 24.1°C

Probe: ES3DV3 - SN3209; ConvF(4.46, 4.46, 4.46); Calibrated: 3/16/2012;

Sensor-Surface: 3mm (Mechanical Surface Detection)

Electronics: DAE4 Sn1323; Calibrated: 2/15/2012

Phantom: SAM Main; Type: SAM 4.0; Serial: TP-1114

Measurement SW: DASY4, Version 4.7 (80); SEMCAD X Version 14.6.5 (6469)

Mode: IEEE 802.11b, Right Head, Tilt, Ch 01, 1 Mbps

Area Scan (10x15x1): Measurement grid: dx=12mm, dy=12mm

Zoom Scan (7x7x7)/Cube 0: Measurement grid: dx=5mm, dy=5mm, dz=5mm

Reference Value = 6.681 V/m; Power Drift = 0.15 dB

Peak SAR (extrapolated) = 0.134 mW/g

SAR(1 g) = 0.071 mW/g; SAR(10 g) = 0.035 mW/g

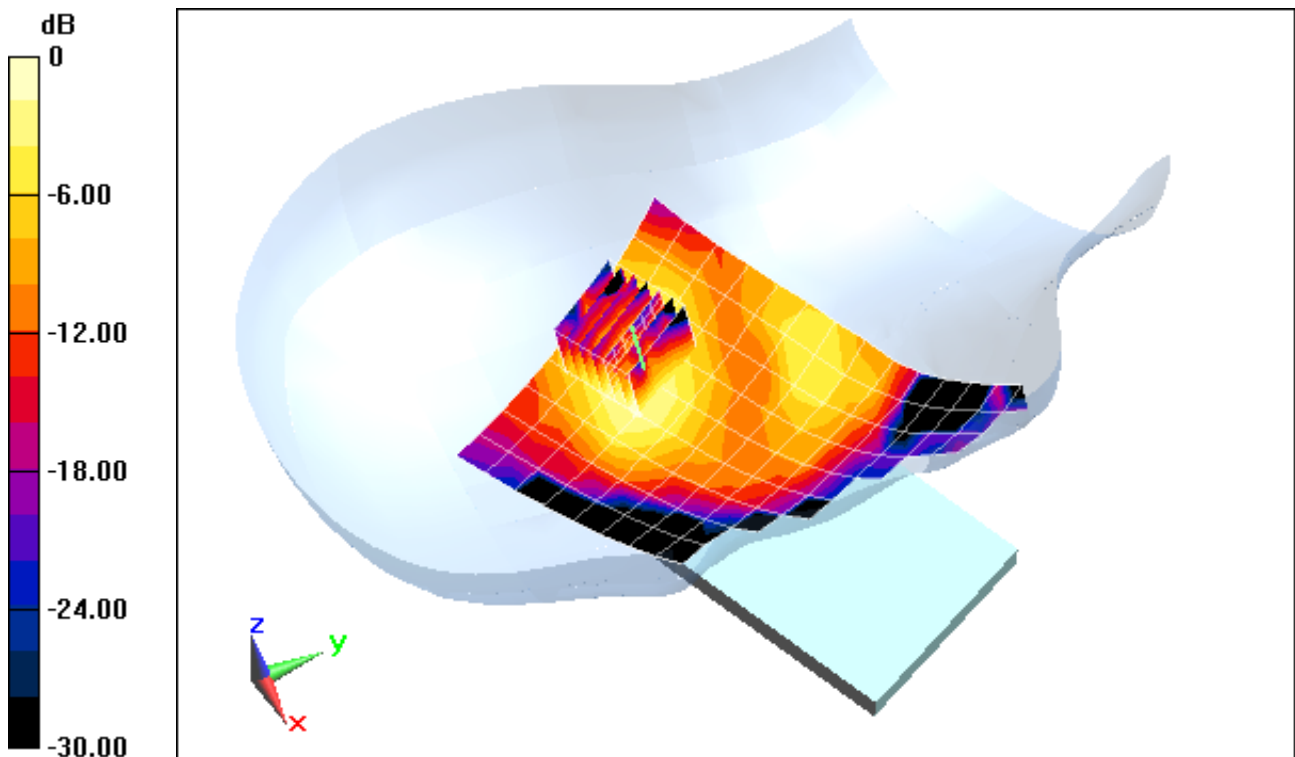

0 dB = 0.0899 mW/g = -20.92 dB mW/g

PCTEST ENGINEERING LABORATORY, INC.

DUT: ZNFE970; Type: Portable Handset; Serial: WI-FI SAR #1

Communication System: IEEE 802.11b; Frequency: 2412 MHz; Duty Cycle: 1:1

Medium: 2450 Head Medium parameters used (interpolated):

$f = 2412 \text{ MHz}$; $\sigma = 1.835 \text{ mho/m}$; $\epsilon_r = 39.06$; $\rho = 1000 \text{ kg/m}^3$

Phantom section: Left Section

Test Date: 07-10-2012; Ambient Temp: 24.2°C; Tissue Temp: 24.1°C

Probe: ES3DV3 - SN3209; ConvF(4.46, 4.46, 4.46); Calibrated: 3/16/2012;

Sensor-Surface: 3mm (Mechanical Surface Detection)

Electronics: DAE4 Sn1323; Calibrated: 2/15/2012

Phantom: SAM Main; Type: SAM 4.0; Serial: TP-1114

Measurement SW: DASY4, Version 4.7 (80); SEMCAD X Version 14.6.5 (6469)

Mode: IEEE 802.11b, Left Head, Cheek, Ch 01, 1 Mbps

Area Scan (10x15x1): Measurement grid: dx=12mm, dy=12mm

Zoom Scan (7x7x7)/Cube 0: Measurement grid: dx=5mm, dy=5mm, dz=5mm

Reference Value = 13.257 V/m; Power Drift = -0.10 dB

Peak SAR (extrapolated) = 0.836 mW/g

SAR(1 g) = 0.330 mW/g; SAR(10 g) = 0.134 mW/g

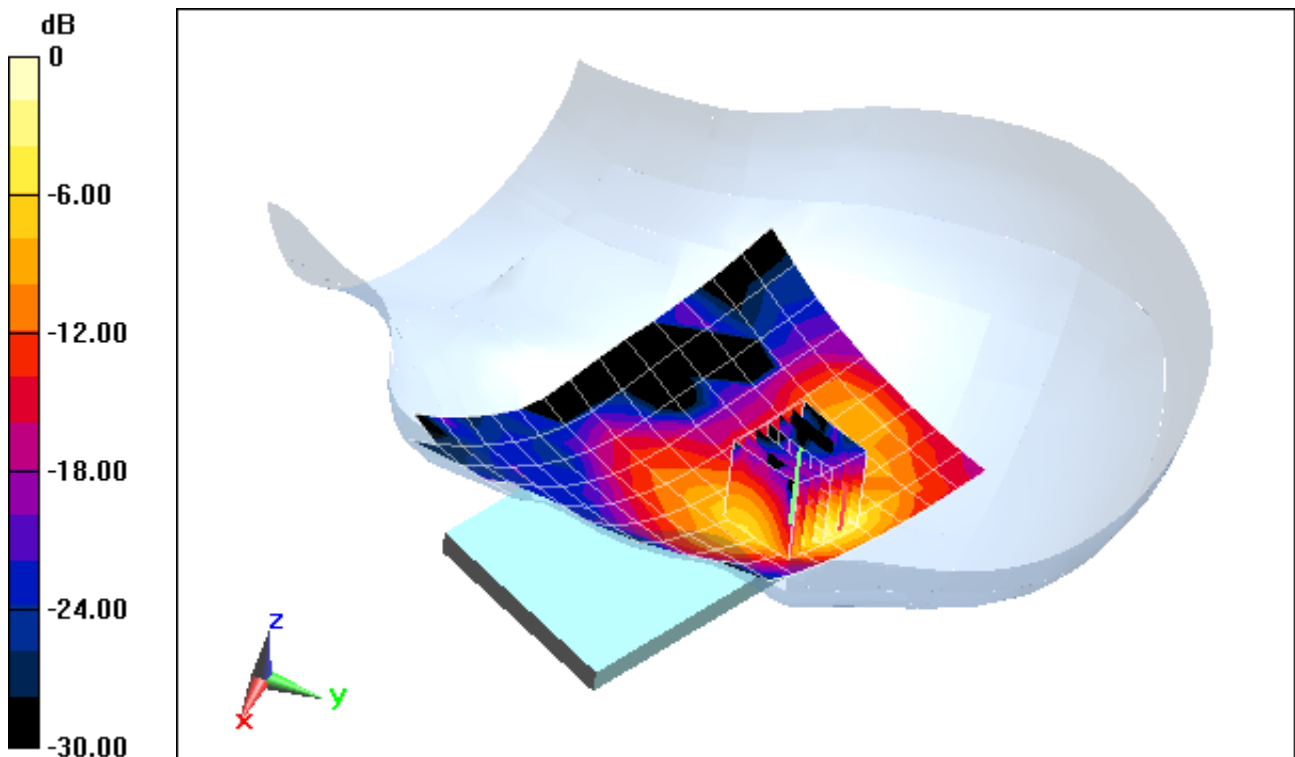

0 dB = 0.453 mW/g = -6.88 dB mW/g

PCTEST ENGINEERING LABORATORY, INC.

DUT: ZNFE970; Type: Portable Handset; Serial: WI-FI SAR #1

Communication System: IEEE 802.11b; Frequency: 2412 MHz; Duty Cycle: 1:1

Medium: 2450 Head Medium parameters used (interpolated):

$f = 2412 \text{ MHz}$; $\sigma = 1.835 \text{ mho/m}$; $\epsilon_r = 39.06$; $\rho = 1000 \text{ kg/m}^3$

Phantom section: Left Section

Test Date: 07-10-2012; Ambient Temp: 24.2°C; Tissue Temp: 24.1°C

Probe: ES3DV3 - SN3209; ConvF(4.46, 4.46, 4.46); Calibrated: 3/16/2012;

Sensor-Surface: 3mm (Mechanical Surface Detection)

Electronics: DAE4 Sn1323; Calibrated: 2/15/2012

Phantom: SAM Main; Type: SAM 4.0; Serial: TP-1114

Measurement SW: DASY4, Version 4.7 (80); SEMCAD X Version 14.6.5 (6469)

Mode: IEEE 802.11b, Left Head, Tilt, Ch 01, 1 Mbps

Area Scan (10x15x1): Measurement grid: dx=12mm, dy=12mm

Zoom Scan (7x7x7)/Cube 0: Measurement grid: dx=5mm, dy=5mm, dz=5mm

Reference Value = 5.882 V/m; Power Drift = 0.38 dB

Peak SAR (extrapolated) = 0.145 mW/g

SAR(1 g) = 0.073 mW/g; SAR(10 g) = 0.032 mW/g

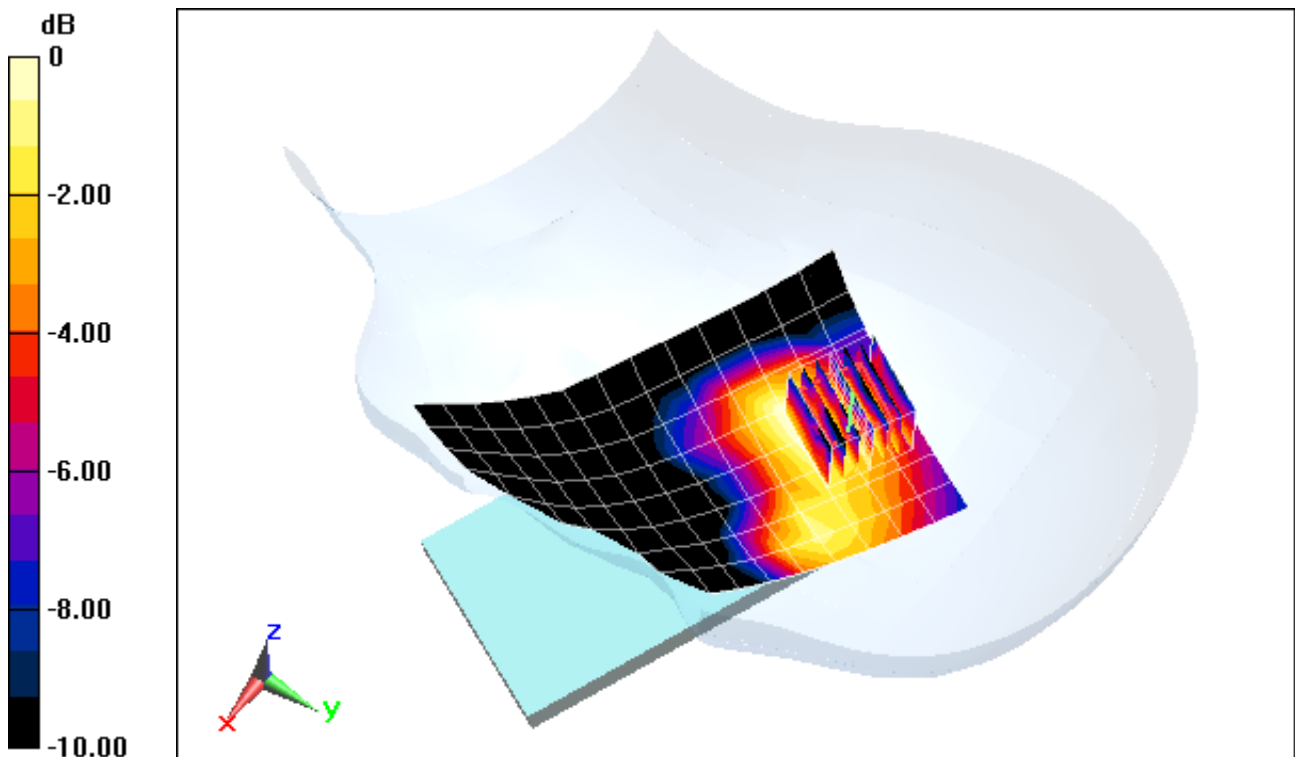

0 dB = 0.0273 mW/g = -31.28 dB mW/g

PCTEST ENGINEERING LABORATORY, INC.

DUT: ZNFE970; Type: Portable Handset; Serial: WI-FI SAR #1

Communication System: IEEE 802.11a 5.2-5.8 GHz Band; Frequency: 5260 MHz; Duty Cycle: 1:1
Medium: 5 GHz Head Medium parameters used:

$$f = 5260 \text{ MHz}; \sigma = 4.545 \text{ mho/m}; \epsilon_r = 35.96; \rho = 1000 \text{ kg/m}^3$$

Phantom section: Right Section

Test Date: 07-09-2012; Ambient Temp: 24.4°C; Tissue Temp: 23.3°C

Probe: EX3DV4 - SN3589; ConvF(4.36, 4.36, 4.36); Calibrated: 1/27/2012;

Sensor-Surface: 2mm (Mechanical Surface Detection)

Electronics: DAE4 Sn1323; Calibrated: 2/15/2012

Phantom: SAM Main; Type: SAM 4.0; Serial: TP-1114

Measurement SW: DASY4, Version 4.7 (80); SEMCAD X Version 14.6.5 (6469)

Mode: IEEE 802.11a 5.3 GHz, Right Head, Cheek, Ch 52, 6 Mbps

Area Scan (12x17x1): Measurement grid: dx=10mm, dy=10mm

Zoom Scan (7x7x12)/Cube 0: Measurement grid: dx=4mm, dy=4mm, dz=2mm

Reference Value = 2.733 V/m; Power Drift = 0.135 dB

Peak SAR (extrapolated) = 0.499 mW/g

SAR(1 g) = 0.055 mW/g; SAR(10 g) = 0.011 mW/g

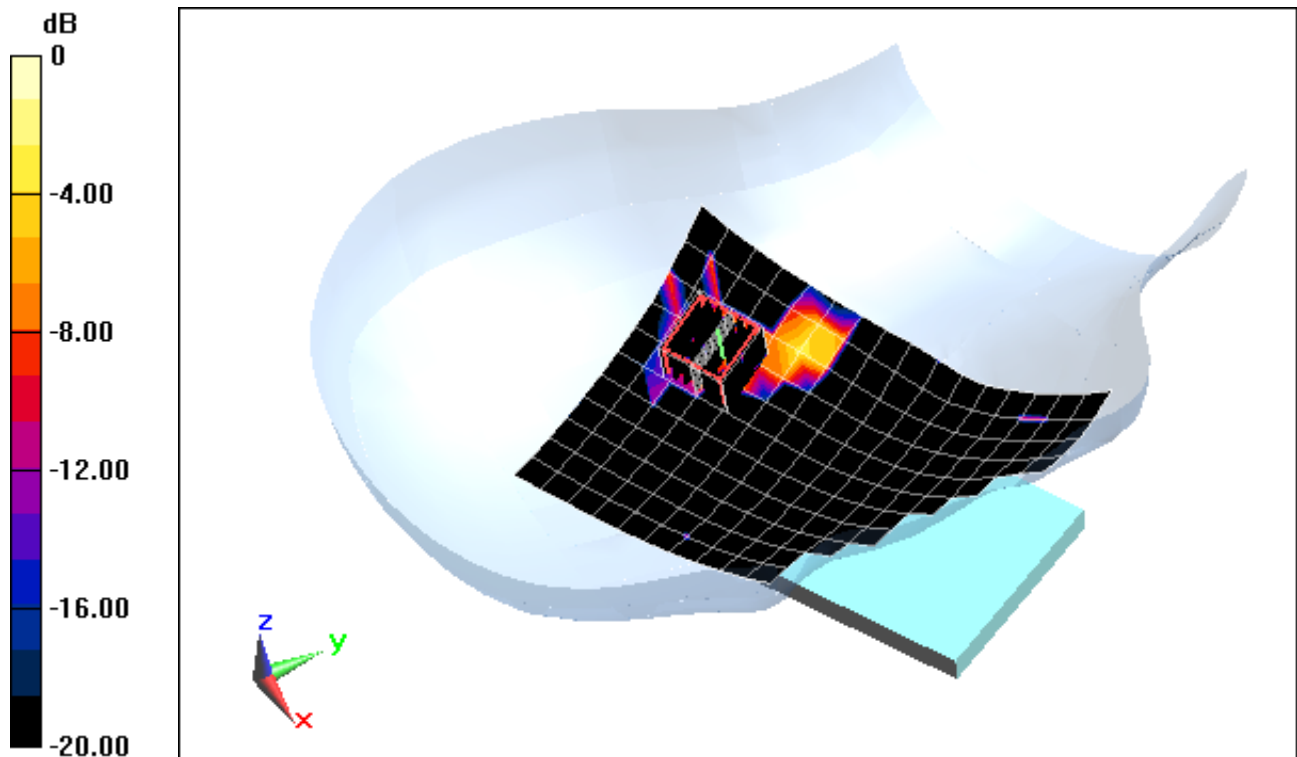

0 dB = 0.125 mW/g = -18.06 dB mW/g

PCTEST ENGINEERING LABORATORY, INC.

DUT: ZNFE970; Type: Portable Handset; Serial: WI-FI SAR #1

Communication System: IEEE 802.11a 5.2-5.8 GHz Band; Frequency: 5260 MHz; Duty Cycle: 1:1
Medium: 5 GHz Head Medium parameters used:

$$f = 5260 \text{ MHz}; \sigma = 4.545 \text{ mho/m}; \epsilon_r = 35.96; \rho = 1000 \text{ kg/m}^3$$

Phantom section: Right Section

Test Date: 07-09-2012; Ambient Temp: 24.4°C; Tissue Temp: 23.3°C

Probe: EX3DV4 - SN3589; ConvF(4.36, 4.36, 4.36); Calibrated: 1/27/2012;

Sensor-Surface: 2mm (Mechanical Surface Detection)

Electronics: DAE4 Sn1323; Calibrated: 2/15/2012

Phantom: SAM Main; Type: SAM 4.0; Serial: TP-1114

Measurement SW: DASY4, Version 4.7 (80); SEMCAD X Version 14.6.5 (6469)

Mode: IEEE 802.11a 5.3 GHz, Right Head, Tilt, Ch 52, 6 Mbps

Area Scan (12x17x1): Measurement grid: dx=10mm, dy=10mm

Zoom Scan (7x7x12)/Cube 0: Measurement grid: dx=4mm, dy=4mm, dz=2mm

Reference Value = 3.226 V/m; Power Drift = 0.126 dB

Peak SAR (extrapolated) = 0.445 mW/g

SAR(1 g) = 0.048 mW/g; SAR(10 g) = 0.011 mW/g

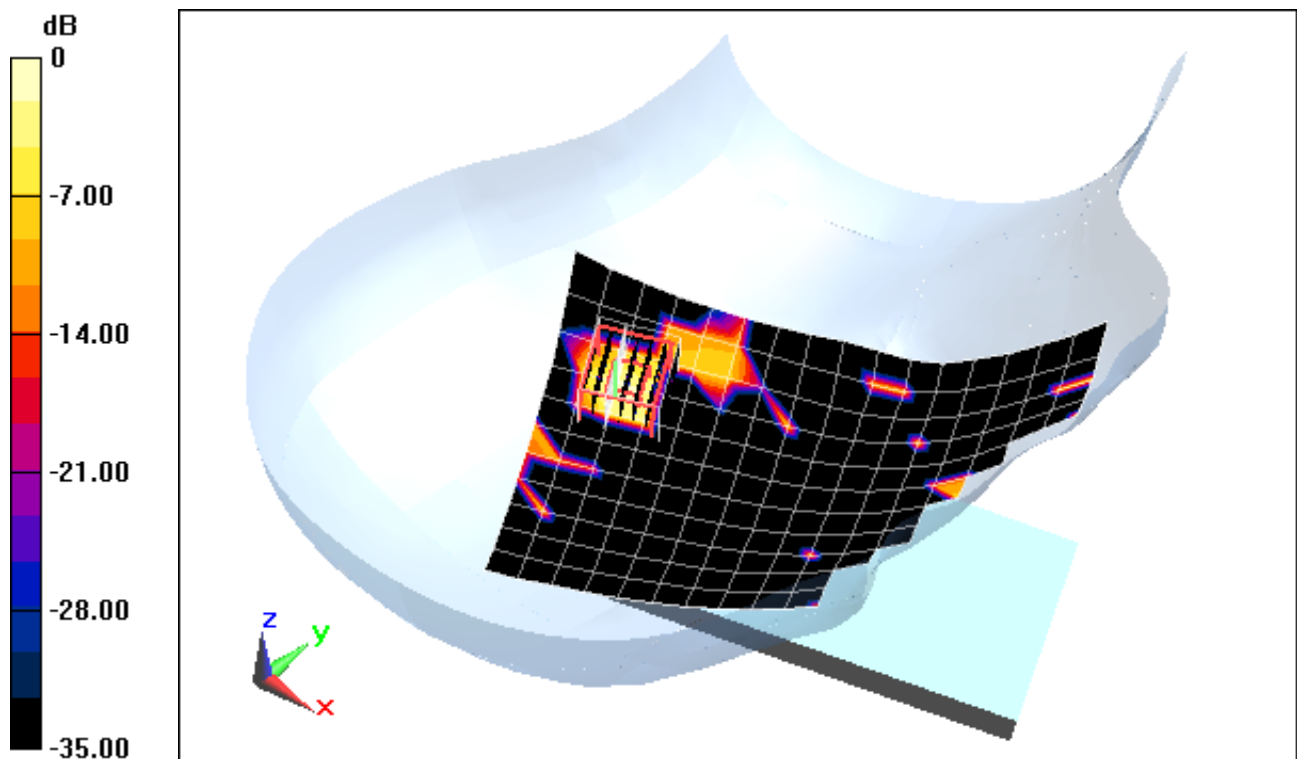

0 dB = 0.115 mW/g = -18.79 dB mW/g

PCTEST ENGINEERING LABORATORY, INC.

DUT: ZNFE970; Type: Portable Handset; Serial: WI-FI SAR #1

Communication System: IEEE 802.11a 5.2-5.8 GHz Band; Frequency: 5260 MHz; Duty Cycle: 1:1

Medium: 5 GHz Head Medium parameters used:

$f = 5260 \text{ MHz}$; $\sigma = 4.545 \text{ mho/m}$; $\epsilon_r = 35.96$; $\rho = 1000 \text{ kg/m}^3$

Phantom section: Left Section

Test Date: 07-09-2012; Ambient Temp: 24.4°C; Tissue Temp: 23.3°C

Probe: EX3DV4 - SN3589; ConvF(4.36, 4.36, 4.36); Calibrated: 1/27/2012;

Sensor-Surface: 2mm (Mechanical Surface Detection)

Electronics: DAE4 Sn1323; Calibrated: 2/15/2012

Phantom: SAM Main; Type: SAM 4.0; Serial: TP-1114

Measurement SW: DASY4, Version 4.7 (80); SEMCAD X Version 14.6.5 (6469)

Mode: IEEE 802.11a, 5.3 GHz Left Head, Cheek, Ch 52, 6 Mbps

Area Scan (12x17x1): Measurement grid: dx=10mm, dy=10mm

Zoom Scan (7x7x12)/Cube 0: Measurement grid: dx=4mm, dy=4mm, dz=2mm

Reference Value = 7.337 V/m; Power Drift = 0.17 dB

Peak SAR (extrapolated) = 0.769 mW/g

SAR(1 g) = 0.195 mW/g; SAR(10 g) = 0.046 mW/g

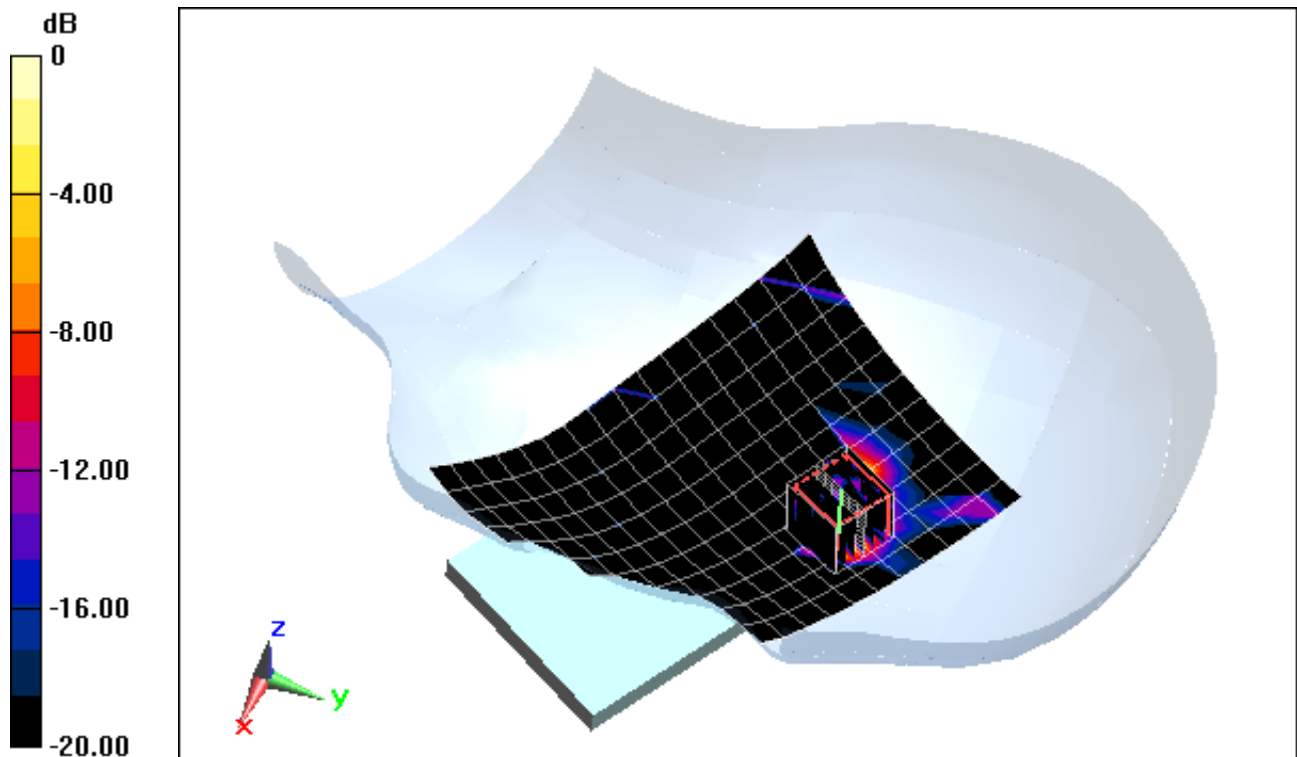

0 dB = 0.446 mW/g = -7.01 dB mW/g

PCTEST ENGINEERING LABORATORY, INC.

DUT: ZNFE970; Type: Portable Handset; Serial: WI-FI SAR #1

Communication System: IEEE 802.11a 5.2-5.8 GHz Band; Frequency: 5260 MHz; Duty Cycle: 1:1

Medium: 5 GHz Head Medium parameters used:

$$f = 5260 \text{ MHz}; \sigma = 4.545 \text{ mho/m}; \epsilon_r = 35.96; \rho = 1000 \text{ kg/m}^3$$

Phantom section: Left Section

Test Date: 07-09-2012; Ambient Temp: 24.4°C; Tissue Temp: 23.3°C

Probe: EX3DV4 - SN3589; ConvF(4.36, 4.36, 4.36); Calibrated: 1/27/2012;

Sensor-Surface: 2mm (Mechanical Surface Detection)

Electronics: DAE4 Sn1323; Calibrated: 2/15/2012

Phantom: SAM Main; Type: SAM 4.0; Serial: TP-1114

Measurement SW: DASY4, Version 4.7 (80); SEMCAD X Version 14.6.5 (6469)

Mode: IEEE 802.11a, 5.3 GHz Left Head, Tilt, Ch 52, 6 Mbps

Area Scan (12x17x1): Measurement grid: dx=10mm, dy=10mm

Zoom Scan (7x7x12)/Cube 0: Measurement grid: dx=4mm, dy=4mm, dz=2mm

Reference Value = 2.668 V/m; Power Drift = -0.08 dB

Peak SAR (extrapolated) = 0.788 mW/g

SAR(1 g) = 0.042 mW/g; SAR(10 g) = 0.00492 mW/g

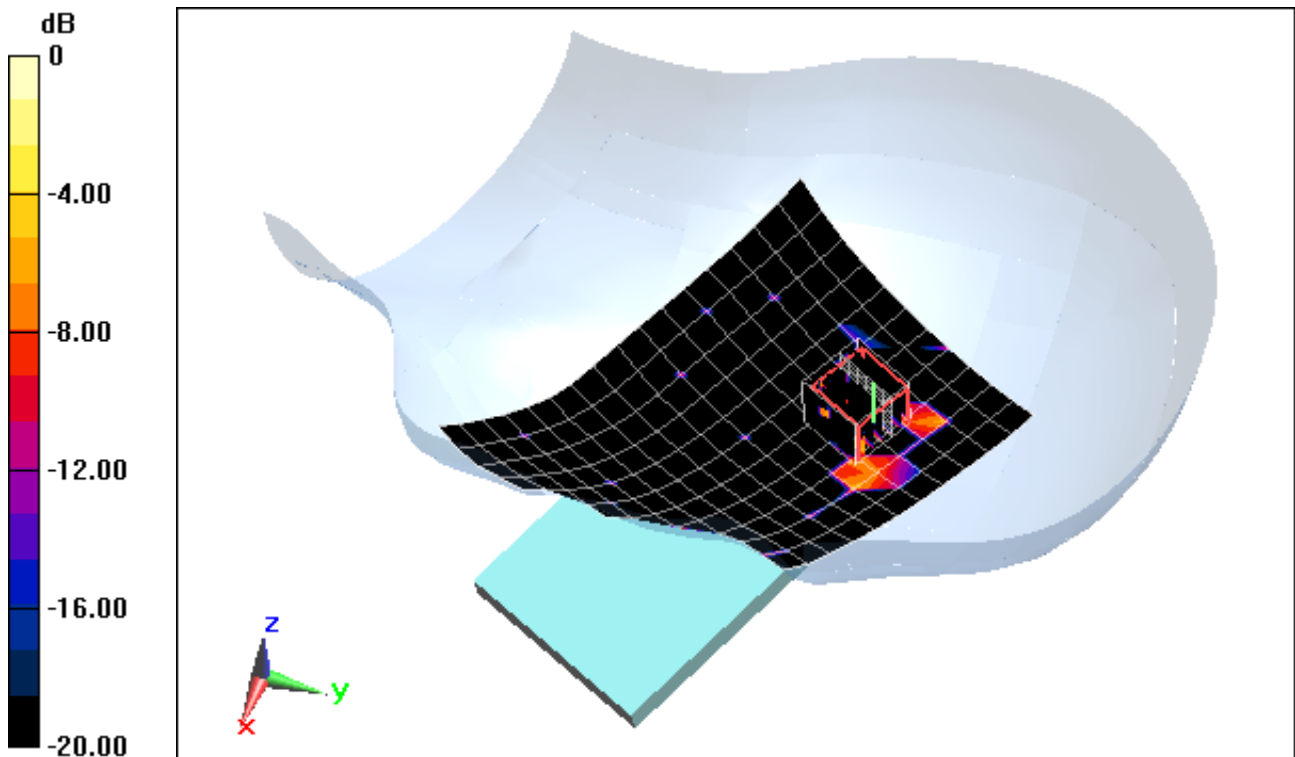

0 dB = 0.118 mW/g = -18.56 dB mW/g

PCTEST ENGINEERING LABORATORY, INC.

DUT: ZNFE970; Type: Portable Handset; Serial: LTE SAR#1

Communication System: LTE BAND 17; Frequency: 710 MHz; Duty Cycle: 1:1

Medium: 740 Body Medium parameters used (interpolated):

$f = 710 \text{ MHz}$; $\sigma = 0.953 \text{ mho/m}$; $\epsilon_r = 54.80$; $\rho = 1000 \text{ kg/m}^3$

Phantom section: Flat Section; Space: 1.0 cm

Test Date: 07-11-2012; Ambient Temp: 24.0°C; Tissue Temp: 22.8°C

Probe: ES3DV2 - SN3022; ConvF(6.11, 6.11, 6.11); Calibrated: 8/25/2011;

Sensor-Surface: 4mm (Mechanical Surface Detection)

Electronics: DAE4 Sn665; Calibrated: 4/19/2012

Phantom: SAM with CRP; Type: SAM; Serial: TP1375

Measurement SW: DASY4, Version 4.7 (80); SEMCAD X Version 14.6.5 (6469)

Mode: LTE Band 17, Body SAR, Back side, Mid.ch
10 MHz Bandwidth, QPSK, 1 RB, 0 RB Offset

Area Scan (9x13x1): Measurement grid: dx=15mm, dy=15mm

Zoom Scan (5x5x7)/Cube 0: Measurement grid: dx=8mm, dy=8mm, dz=5mm

Reference Value = 22.443 V/m; Power Drift = 0.02 dB

Peak SAR (extrapolated) = 0.772 mW/g

SAR(1 g) = 0.447 mW/g; SAR(10 g) = 0.291 mW/g

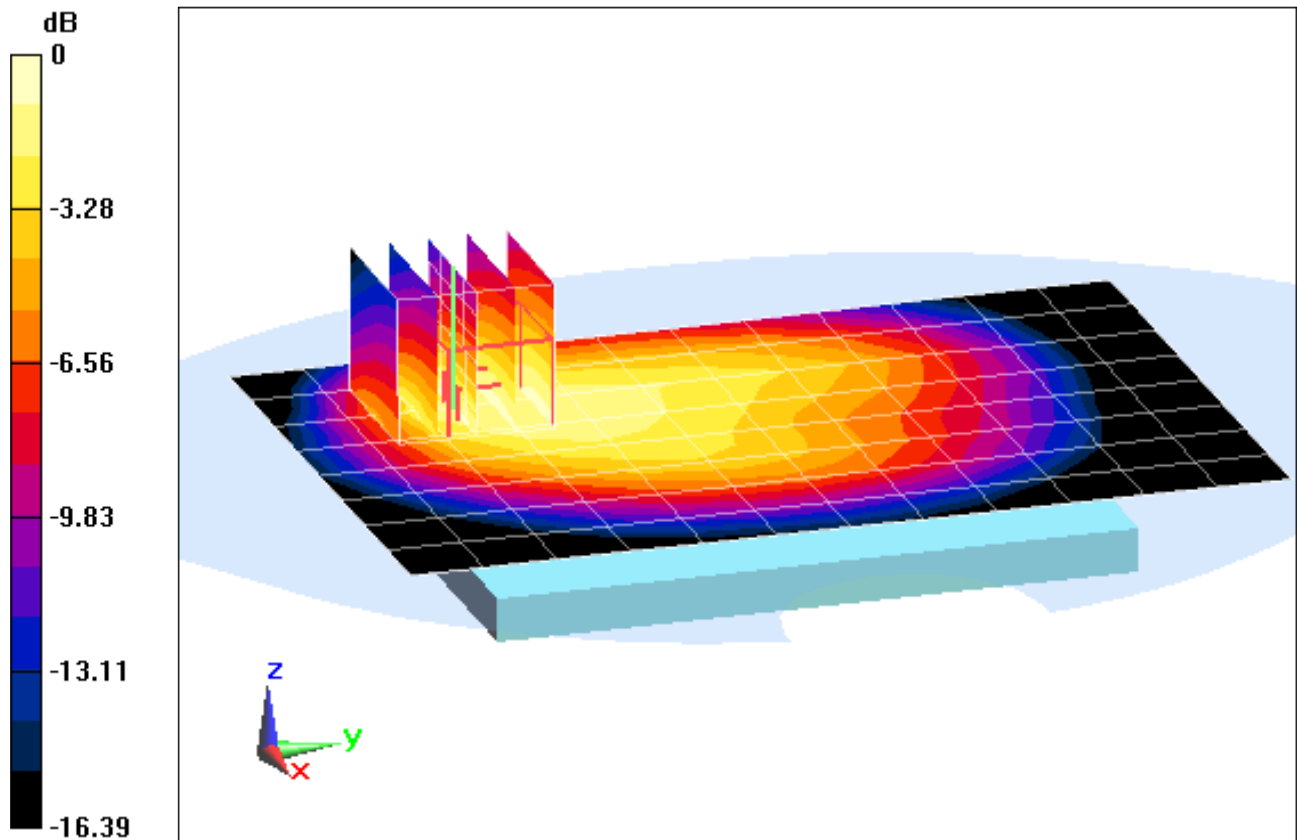

0 dB = 0.471 mW/g = -6.54 dB mW/g

PCTEST ENGINEERING LABORATORY, INC.

DUT: ZNFE970; Type: Portable Handset; Serial: LTE SAR#1

Communication System: LTE BAND 17; Frequency: 710 MHz; Duty Cycle: 1:1

Medium: 740 Body Medium parameters used (interpolated):

$f = 710 \text{ MHz}$; $\sigma = 0.953 \text{ mho/m}$; $\epsilon_r = 54.80$; $\rho = 1000 \text{ kg/m}^3$

Phantom section: Flat Section; Space: 1.0 cm

Test Date: 07-11-2012; Ambient Temp: 24.0°C; Tissue Temp: 22.8°C

Probe: ES3DV2 - SN3022; ConvF(6.11, 6.11, 6.11); Calibrated: 8/25/2011;

Sensor-Surface: 4mm (Mechanical Surface Detection)

Electronics: DAE4 Sn665; Calibrated: 4/19/2012

Phantom: SAM with CRP; Type: SAM; Serial: TP1375

Measurement SW: DASY4, Version 4.7 (80); SEMCAD X Version 14.6.5 (6469)

Mode: LTE Band 17, Body SAR, Front side, Mid.ch
10 MHz Bandwidth, QPSK, 1 RB, 49 RB Offset

Area Scan (9x13x1): Measurement grid: dx=15mm, dy=15mm

Zoom Scan (5x5x7)/Cube 0: Measurement grid: dx=8mm, dy=8mm, dz=5mm

Reference Value = 17.034 V/m; Power Drift = 0.00 dB

Peak SAR (extrapolated) = 0.391 mW/g

SAR(1 g) = 0.255 mW/g; SAR(10 g) = 0.180 mW/g

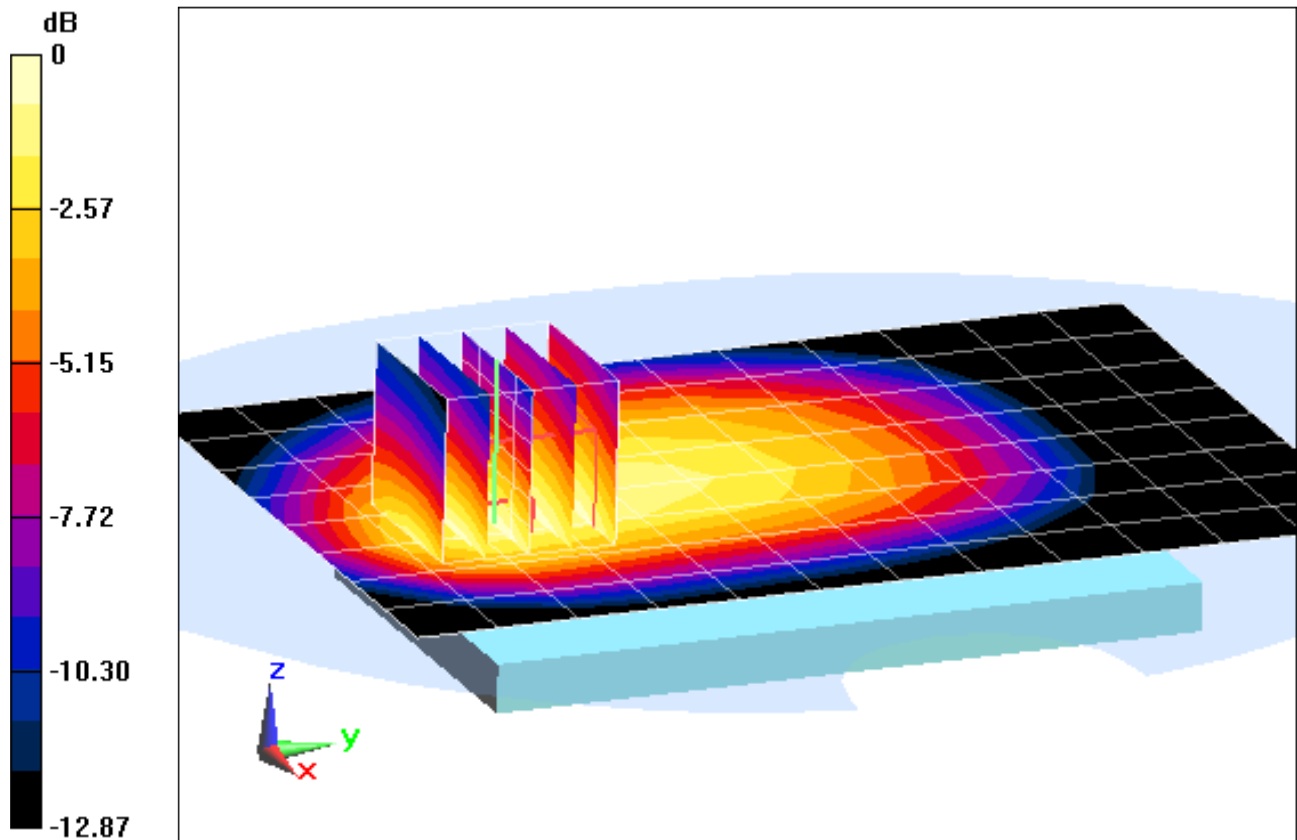

0 dB = 0.272 mW/g = -11.31 dB mW/g

PCTEST ENGINEERING LABORATORY, INC.

DUT: ZNFE970; Type: Portable Handset; Serial: LTE SAR#1

Communication System: LTE BAND 17; Frequency: 710 MHz; Duty Cycle: 1:1

Medium: 740 Body Medium parameters used (interpolated):

$f = 710 \text{ MHz}$; $\sigma = 0.953 \text{ mho/m}$; $\epsilon_r = 54.80$; $\rho = 1000 \text{ kg/m}^3$

Phantom section: Flat Section; Space: 1.0 cm

Test Date: 07-11-2012; Ambient Temp: 24.0°C; Tissue Temp: 22.8°C

Probe: ES3DV2 - SN3022; ConvF(6.11, 6.11, 6.11); Calibrated: 8/25/2011;

Sensor-Surface: 4mm (Mechanical Surface Detection)

Electronics: DAE4 Sn665; Calibrated: 4/19/2012

Phantom: SAM with CRP; Type: SAM; Serial: TP1375

Measurement SW: DASY4, Version 4.7 (80); SEMCAD X Version 14.6.5 (6469)

Mode: LTE Band 17, Body SAR, Bottom Edge, Mid.ch
10 MHz Bandwidth, QPSK, 1 RB, 49 RB Offset

Area Scan (5x7x1): Measurement grid: dx=15mm, dy=15mm

Zoom Scan (5x5x7)/Cube 0: Measurement grid: dx=8mm, dy=8mm, dz=5mm

Reference Value = 13.347 V/m; Power Drift = -0.04 dB

Peak SAR (extrapolated) = 0.272 mW/g

SAR(1 g) = 0.150 mW/g; SAR(10 g) = 0.092 mW/g

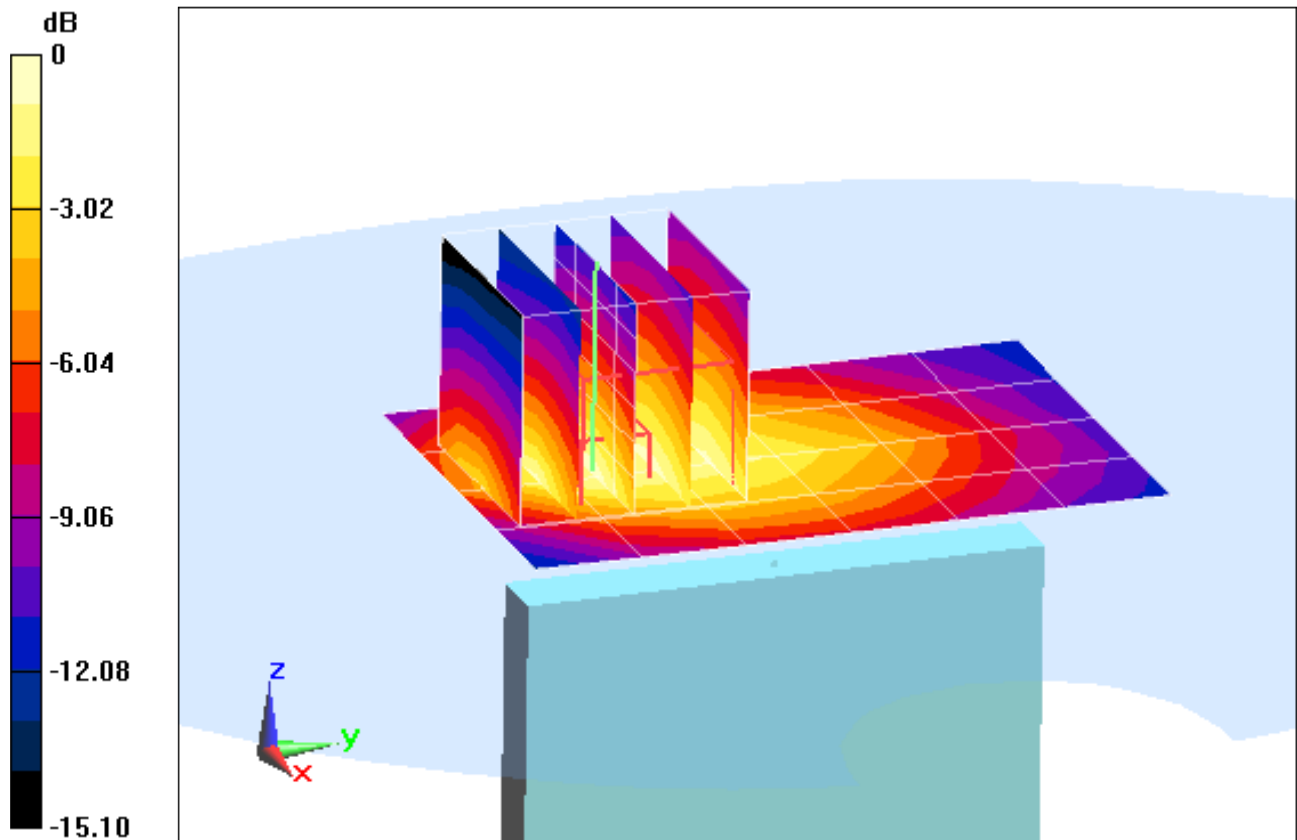

0 dB = 0.162 mW/g = -15.81 dB mW/g

PCTEST ENGINEERING LABORATORY, INC.

DUT: ZNFE970; Type: Portable Handset; Serial: LTE SAR#1

Communication System: LTE BAND 17; Frequency: 710 MHz; Duty Cycle: 1:1

Medium: 740 Body Medium parameters used (interpolated):

$f = 710 \text{ MHz}$; $\sigma = 0.953 \text{ mho/m}$; $\epsilon_r = 54.80$; $\rho = 1000 \text{ kg/m}^3$

Phantom section: Flat Section; Space: 1.0 cm

Test Date: 07-11-2012; Ambient Temp: 24.0°C; Tissue Temp: 22.8°C

Probe: ES3DV2 - SN3022; ConvF(6.11, 6.11, 6.11); Calibrated: 8/25/2011;

Sensor-Surface: 4mm (Mechanical Surface Detection)

Electronics: DAE4 Sn665; Calibrated: 4/19/2012

Phantom: SAM with CRP; Type: SAM; Serial: TP1375

Measurement SW: DASY4, Version 4.7 (80); SEMCAD X Version 14.6.5 (6469)

Mode: LTE Band 17, Body SAR, Right Edge, Mid.ch
10 MHz Bandwidth, QPSK, 1 RB, 0 RB Offset

Area Scan (5x13x1): Measurement grid: dx=15mm, dy=15mm

Zoom Scan (5x5x7)/Cube 0: Measurement grid: dx=8mm, dy=8mm, dz=5mm

Reference Value = 21.122 V/m; Power Drift = 0.07 dB

Peak SAR (extrapolated) = 0.546 mW/g

SAR(1 g) = 0.395 mW/g; SAR(10 g) = 0.275 mW/g

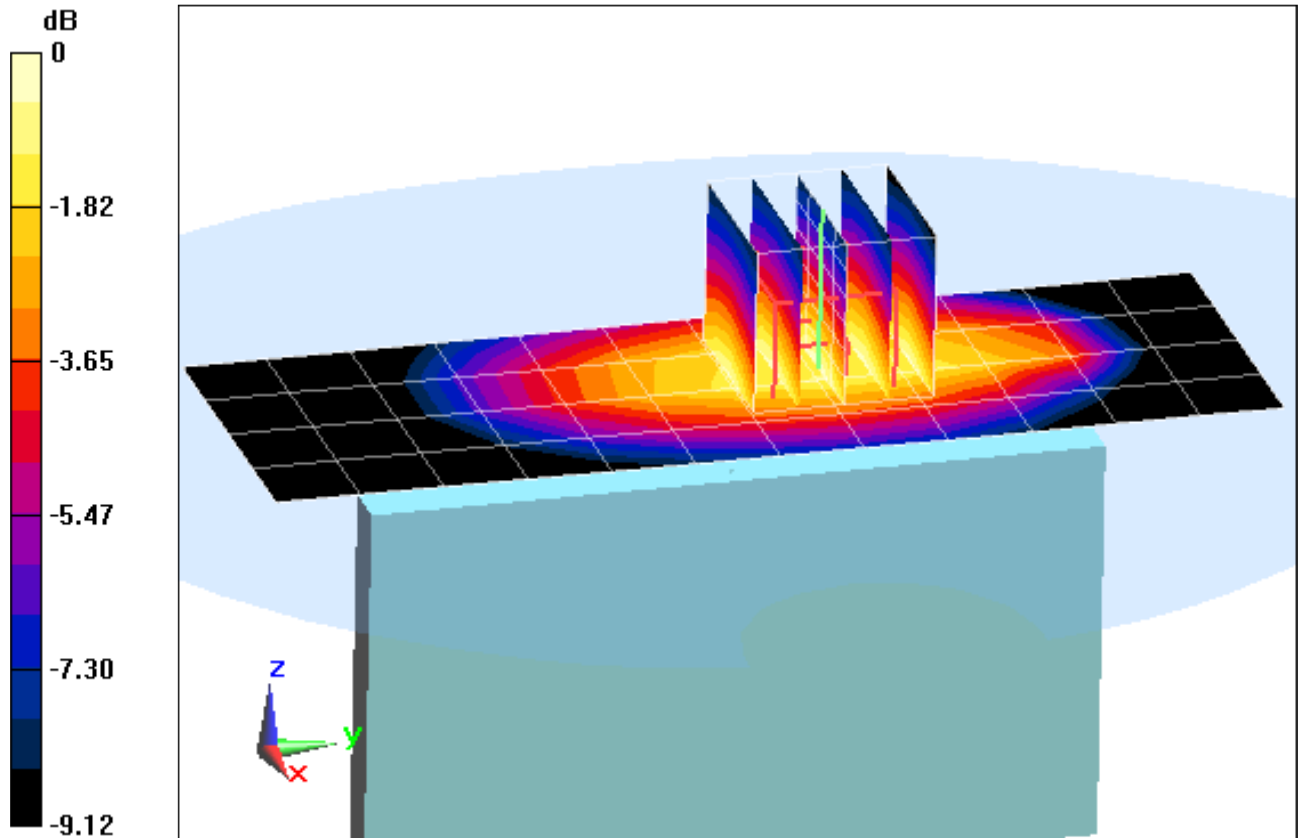

0 dB = 0.422 mW/g = -7.49 dB mW/g

PCTEST ENGINEERING LABORATORY, INC.

DUT: ZNFE970; Type: Portable Handset; Serial: 2G/3G SAR#1

Communication System: GSM850 GPRS; 2 Tx slots; Frequency: 836.6 MHz; Duty Cycle: 1:4.15

Medium: 835 Body Medium parameters used (interpolated):

$f = 836.6 \text{ MHz}$; $\sigma = 0.977 \text{ mho/m}$; $\epsilon_r = 52.604$; $\rho = 1000 \text{ kg/m}^3$

Phantom section: Flat Section; Space: 1.0 cm

Test Date: 07-09-2012; Ambient Temp: 24.9°C; Tissue Temp: 23.3C

Probe: ES3DV3 - SN3258; ConvF(6.06, 6.06, 6.06); Calibrated: 2/21/2012;

Sensor-Surface: 4mm (Mechanical Surface Detection)

Electronics: DAE4 Sn1272; Calibrated: 1/18/2012

Phantom: SAM Main; Type: SAM 4.0; Serial: TP-1406

Measurement SW: DASY4, Version 4.7 (80); SEMCAD X Version 14.6.5 (6469)

Mode: GPRS 850, Body SAR, Back side, Mid.ch, 2 Tx Slots

Area Scan (7x12x1): Measurement grid: dx=15mm, dy=15mm

Zoom Scan (5x5x7)/Cube 0: Measurement grid: dx=8mm, dy=8mm, dz=5mm

Reference Value = 29.102 V/m; Power Drift = -0.04 dB

Peak SAR (extrapolated) = 1.074 mW/g

SAR(1 g) = 0.730 mW/g; SAR(10 g) = 0.518 mW/g

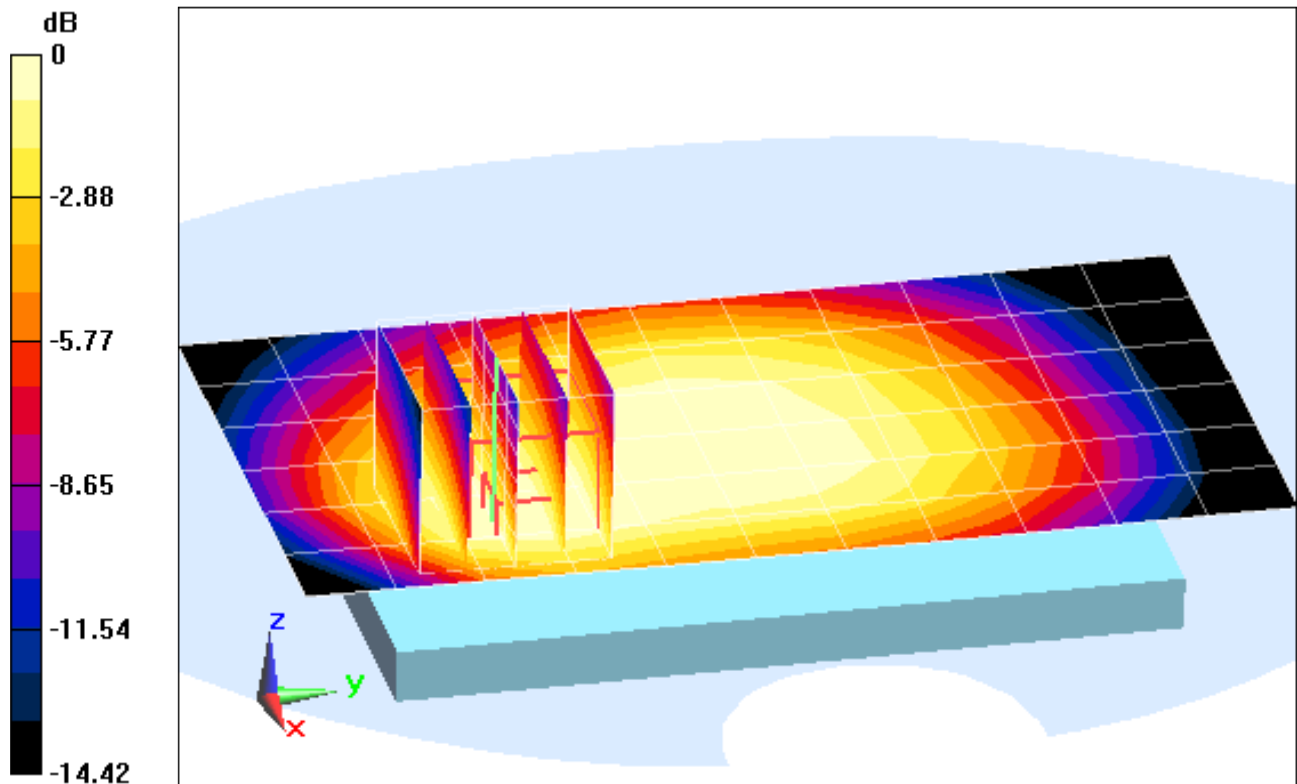

0 dB = 0.767 mW/g = -2.30 dB mW/g

PCTEST ENGINEERING LABORATORY, INC.

DUT: ZNFE970; Type: Portable Handset; Serial: 2G/3G SAR#1

Communication System: GSM 850 GPRS; 2 Tx slots; Frequency: 836.6 MHz; Duty Cycle: 1:4.15

Medium: 835 Body Medium parameters used (interpolated):

$f = 836.6 \text{ MHz}$; $\sigma = 0.977 \text{ mho/m}$; $\epsilon_r = 52.604$; $\rho = 1000 \text{ kg/m}^3$

Phantom section: Flat Section; Space: 1.0 cm

Test Date: 07-09-2012; Ambient Temp: 24.9°C; Tissue Temp: 23.3C

Probe: ES3DV3 - SN3258; ConvF(6.06, 6.06, 6.06); Calibrated: 2/21/2012;

Sensor-Surface: 4mm (Mechanical Surface Detection)

Electronics: DAE4 Sn1272; Calibrated: 1/18/2012

Phantom: SAM Main; Type: SAM 4.0; Serial: TP-1406

Measurement SW: DASY4, Version 4.7 (80); SEMCAD X Version 14.6.5 (6469)

Mode: GPRS 850, Body SAR, Front side, Mid.ch, 2 Tx Slots

Area Scan (7x12x1): Measurement grid: dx=15mm, dy=15mm

Zoom Scan (5x5x7)/Cube 0: Measurement grid: dx=8mm, dy=8mm, dz=5mm

Reference Value = 28.292 V/m; Power Drift = -0.02 dB

Peak SAR (extrapolated) = 0.931 mW/g

SAR(1 g) = 0.736 mW/g; SAR(10 g) = 0.561 mW/g

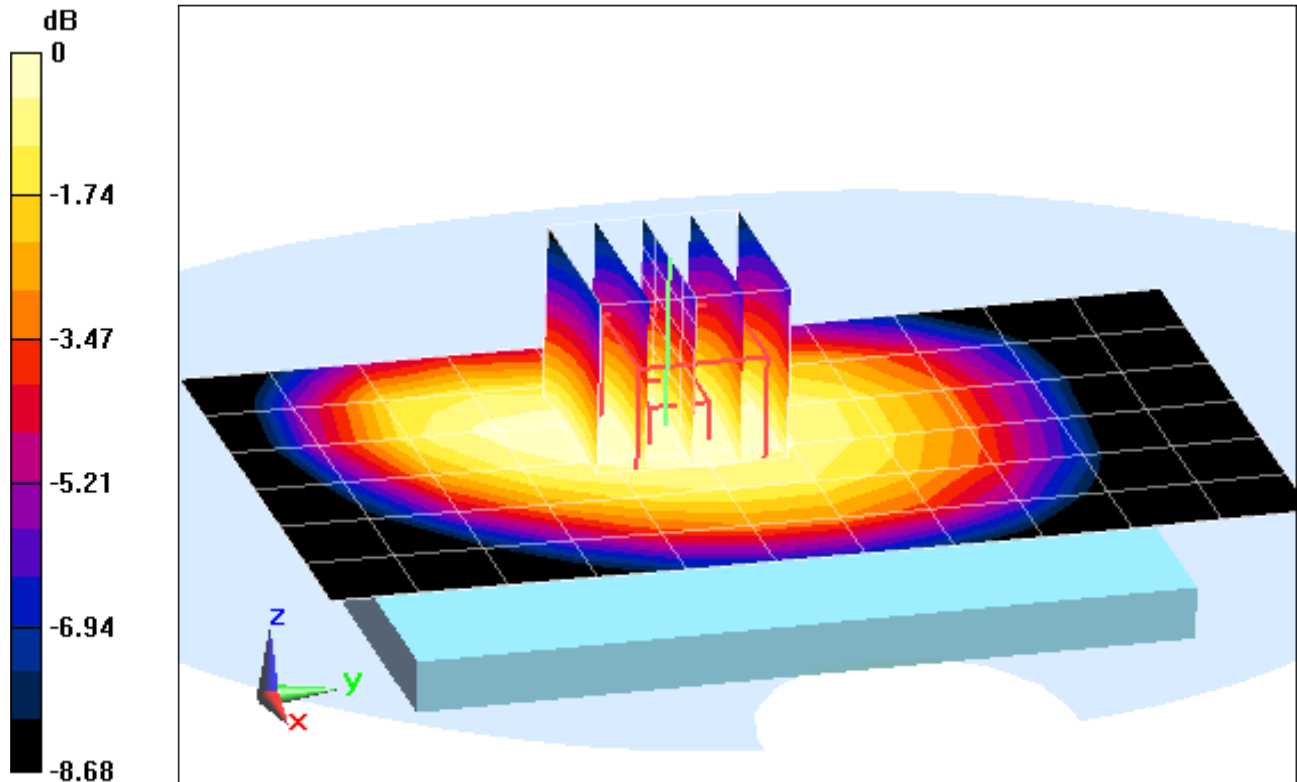

0 dB = 0.775 mW/g = -2.21 dB mW/g

PCTEST ENGINEERING LABORATORY, INC.

DUT: ZNFE970; Type: Portable Handset; Serial: 2G/3G SAR#1

Communication System: GSM 850 GPRS; 2 Tx slots; Frequency: 836.6 MHz; Duty Cycle: 1:4.15

Medium: 835 Body Medium parameters used (interpolated):

$f = 836.6 \text{ MHz}$; $\sigma = 0.977 \text{ mho/m}$; $\epsilon_r = 52.604$; $\rho = 1000 \text{ kg/m}^3$

Phantom section: Flat Section; Space: 1.0 cm

Test Date: 07-09-2012; Ambient Temp: 24.9°C; Tissue Temp: 23.3C

Probe: ES3DV3 - SN3258; ConvF(6.06, 6.06, 6.06); Calibrated: 2/21/2012;

Sensor-Surface: 4mm (Mechanical Surface Detection)

Electronics: DAE4 Sn1272; Calibrated: 1/18/2012

Phantom: SAM Main; Type: SAM 4.0; Serial: TP-1406

Measurement SW: DASY4, Version 4.7 (80); SEMCAD X Version 14.6.5 (6469)

Mode: GPRS 850, Body SAR, Bottom Edge, Mid.ch, 2 Tx Slots

Area Scan (5x7x1): Measurement grid: dx=15mm, dy=15mm

Zoom Scan (5x5x7)/Cube 0: Measurement grid: dx=8mm, dy=8mm, dz=5mm

Reference Value = 14.591 V/m; Power Drift = -0.12 dB

Peak SAR (extrapolated) = 0.262 mW/g

SAR(1 g) = 0.186 mW/g; SAR(10 g) = 0.123 mW/g

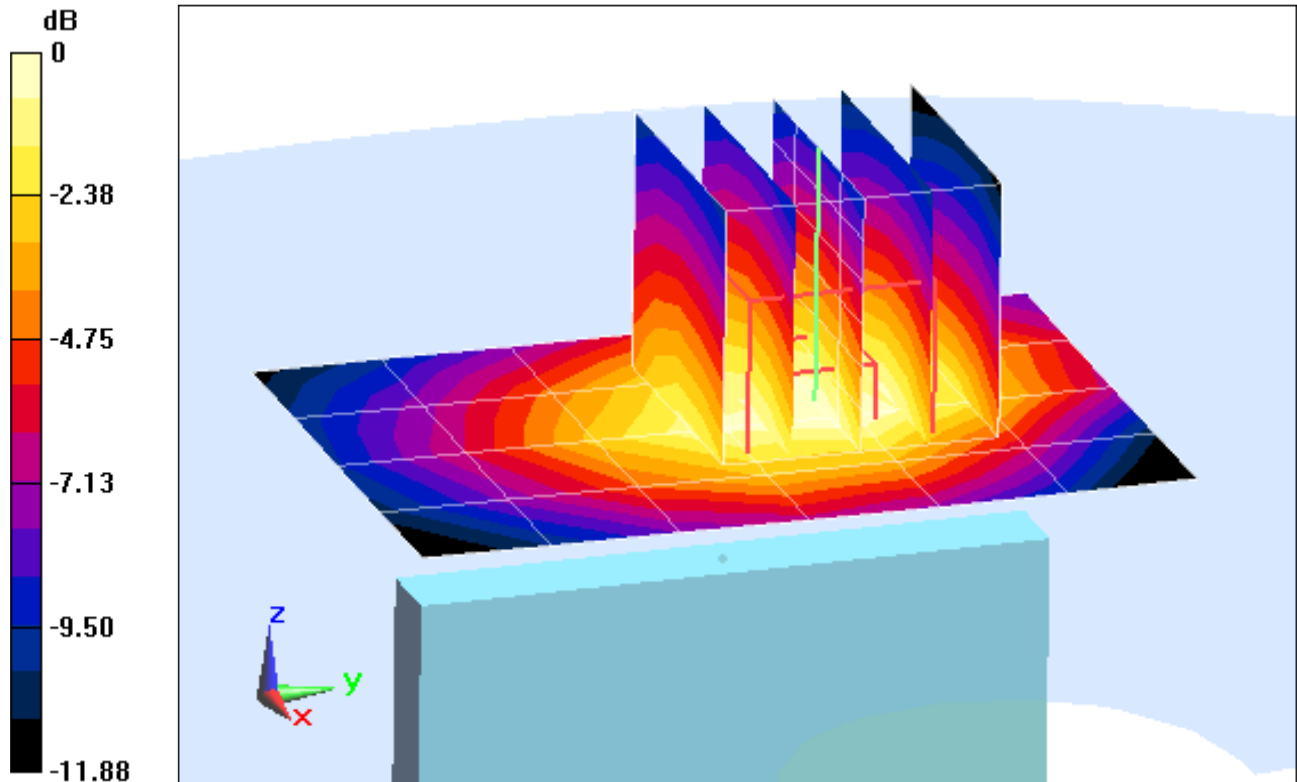

0 dB = 0.201 mW/g = -13.94 dB mW/g

PCTEST ENGINEERING LABORATORY, INC.

DUT: ZNFE970; Type: Portable Handset; Serial: 2G/3G SAR#1

Communication System: GSM 850 GPRS; 2 Tx slots; Frequency: 836.6 MHz; Duty Cycle: 1:4.15

Medium: 835 Body Medium parameters used (interpolated):

$f = 836.6 \text{ MHz}$; $\sigma = 0.977 \text{ mho/m}$; $\epsilon_r = 52.604$; $\rho = 1000 \text{ kg/m}^3$

Phantom section: Flat Section; Space: 1.0 cm

Test Date: 07-09-2012; Ambient Temp: 24.9°C; Tissue Temp: 23.3C

Probe: ES3DV3 - SN3258; ConvF(6.06, 6.06, 6.06); Calibrated: 2/21/2012;

Sensor-Surface: 4mm (Mechanical Surface Detection)

Electronics: DAE4 Sn1272; Calibrated: 1/18/2012

Phantom: SAM Main; Type: SAM 4.0; Serial: TP-1406

Measurement SW: DASY4, Version 4.7 (80); SEMCAD X Version 14.6.5 (6469)

Mode: GPRS 850, Body SAR, Left Edge, Mid.ch, 2 Tx Slots

Area Scan (5x13x1): Measurement grid: dx=15mm, dy=15mm

Zoom Scan (5x5x7)/Cube 0: Measurement grid: dx=8mm, dy=8mm, dz=5mm

Reference Value = 28.727 V/m; Power Drift = 0.08 dB

Peak SAR (extrapolated) = 1.000 mW/g

SAR(1 g) = 0.728 mW/g; SAR(10 g) = 0.509 mW/g

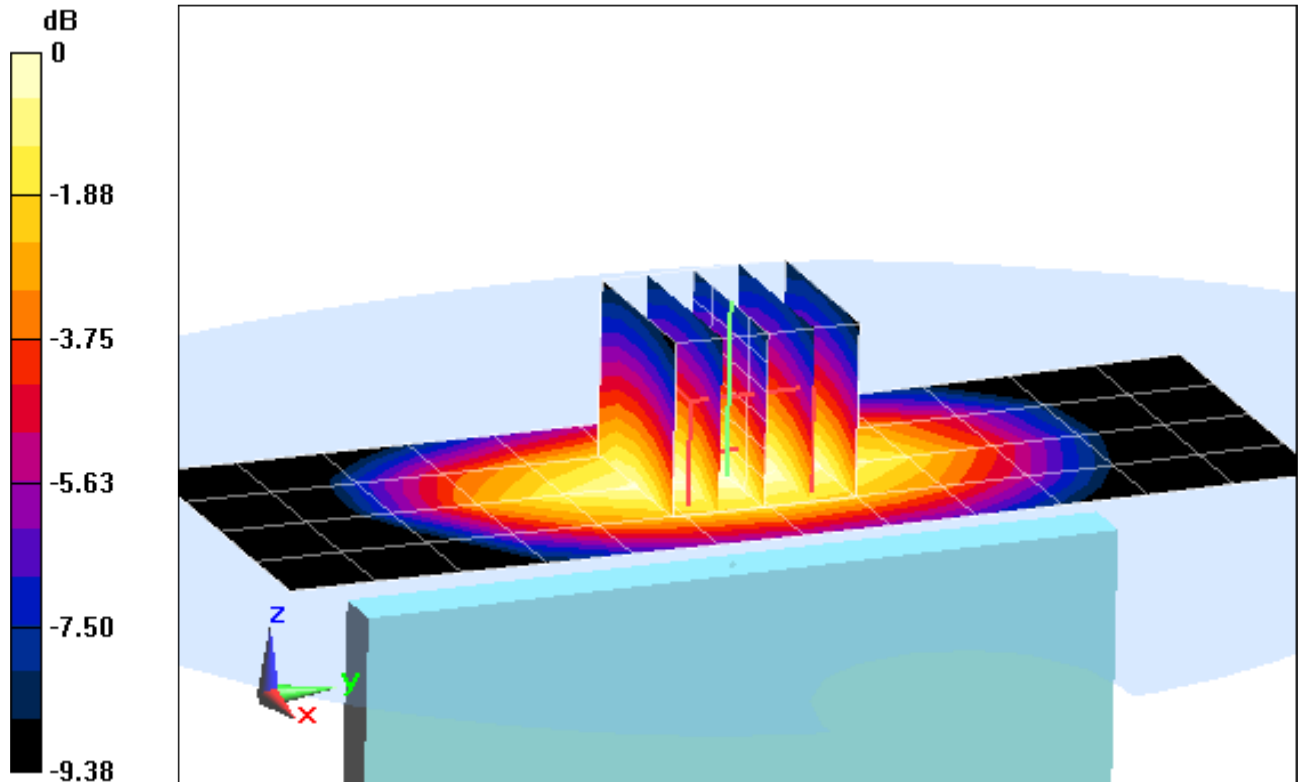

0 dB = 0.776 mW/g = -2.20 dB mW/g

PCTEST ENGINEERING LABORATORY, INC.

DUT: ZNFE970; Type: Portable Handset; Serial: 2G/3G SAR#1

Communication System: WCDMA850; Frequency: 836.6 MHz; Duty Cycle: 1:1

Medium: 835 Body Medium parameters used (interpolated):

$f = 836.6 \text{ MHz}$; $\sigma = 0.977 \text{ mho/m}$; $\epsilon_r = 52.604$; $\rho = 1000 \text{ kg/m}^3$

Phantom section: Flat Section; Space: 1.0 cm

Test Date: 07-09-2012; Ambient Temp: 24.9°C; Tissue Temp: 23.3C

Probe: ES3DV3 - SN3258; ConvF(6.06, 6.06, 6.06); Calibrated: 2/21/2012;

Sensor-Surface: 4mm (Mechanical Surface Detection)

Electronics: DAE4 Sn1272; Calibrated: 1/18/2012

Phantom: SAM Main; Type: SAM 4.0; Serial: TP-1406

Measurement SW: DASY4, Version 4.7 (80); SEMCAD X Version 14.6.5 (6469)

Mode: WCDMA 850, Body SAR, Back side, Mid.ch

Area Scan (7x12x1): Measurement grid: dx=15mm, dy=15mm

Zoom Scan (5x5x7)/Cube 0: Measurement grid: dx=8mm, dy=8mm, dz=5mm

Reference Value = 24.931 V/m; Power Drift = 0.02 dB

Peak SAR (extrapolated) = 0.787 mW/g

SAR(1 g) = 0.538 mW/g; SAR(10 g) = 0.391 mW/g

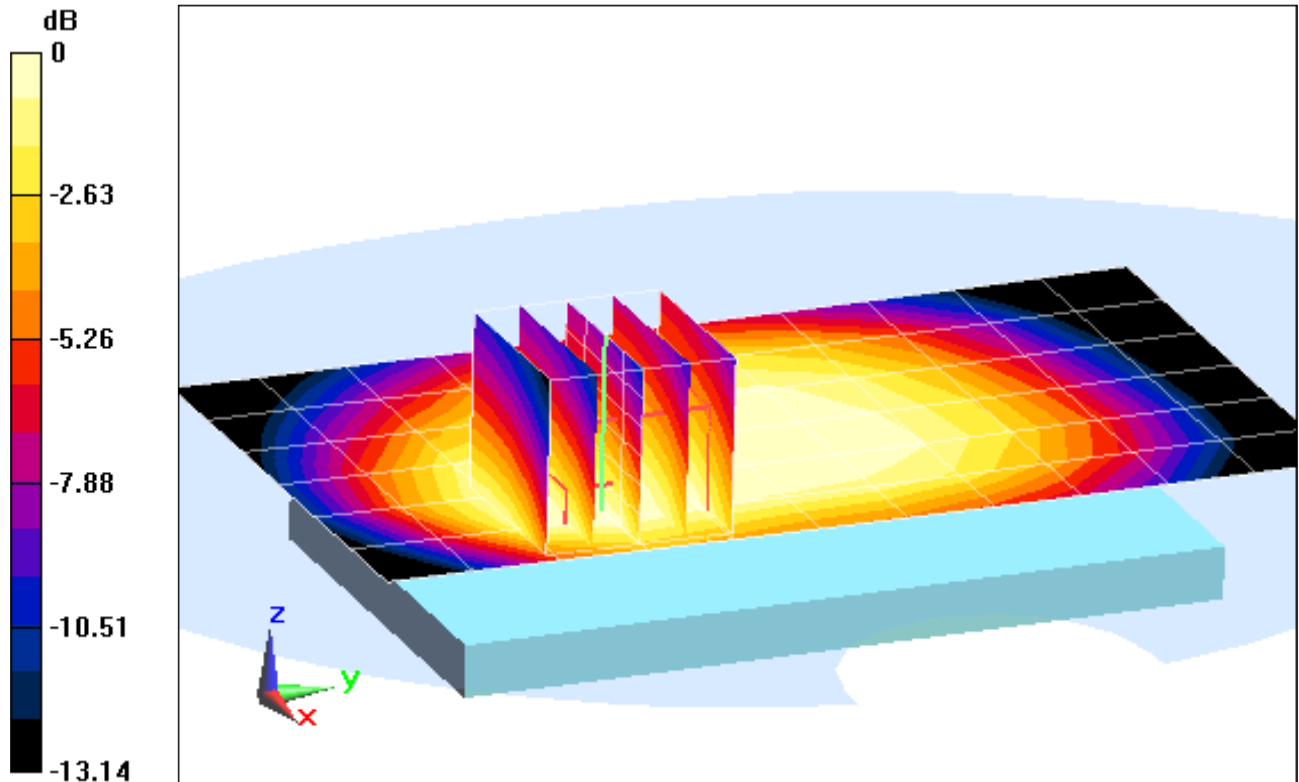

0 dB = 0.565 mW/g = -4.96 dB mW/g

PCTEST ENGINEERING LABORATORY, INC.

DUT: ZNFE970; Type: Portable Handset; Serial: 2G/3G SAR#1

Communication System: WCDMA850; Frequency: 836.6 MHz; Duty Cycle: 1:1

Medium: 835 Body Medium parameters used (interpolated):

$f = 836.6 \text{ MHz}$; $\sigma = 0.977 \text{ mho/m}$; $\epsilon_r = 52.604$; $\rho = 1000 \text{ kg/m}^3$

Phantom section: Flat Section; Space: 1.0 cm

Test Date: 07-09-2012; Ambient Temp: 24.9°C; Tissue Temp: 23.3C

Probe: ES3DV3 - SN3258; ConvF(6.06, 6.06, 6.06); Calibrated: 2/21/2012;

Sensor-Surface: 4mm (Mechanical Surface Detection)

Electronics: DAE4 Sn1272; Calibrated: 1/18/2012

Phantom: SAM Main; Type: SAM 4.0; Serial: TP-1406

Measurement SW: DASY4, Version 4.7 (80); SEMCAD X Version 14.6.5 (6469)

Mode: WCDMA 850, Body SAR, Front side, Mid.ch

Area Scan (7x12x1): Measurement grid: dx=15mm, dy=15mm

Zoom Scan (5x5x7)/Cube 0: Measurement grid: dx=8mm, dy=8mm, dz=5mm

Reference Value = 22.001 V/m; Power Drift = -0.02 dB

Peak SAR (extrapolated) = 0.572 mW/g

SAR(1 g) = 0.451 mW/g; SAR(10 g) = 0.346 mW/g

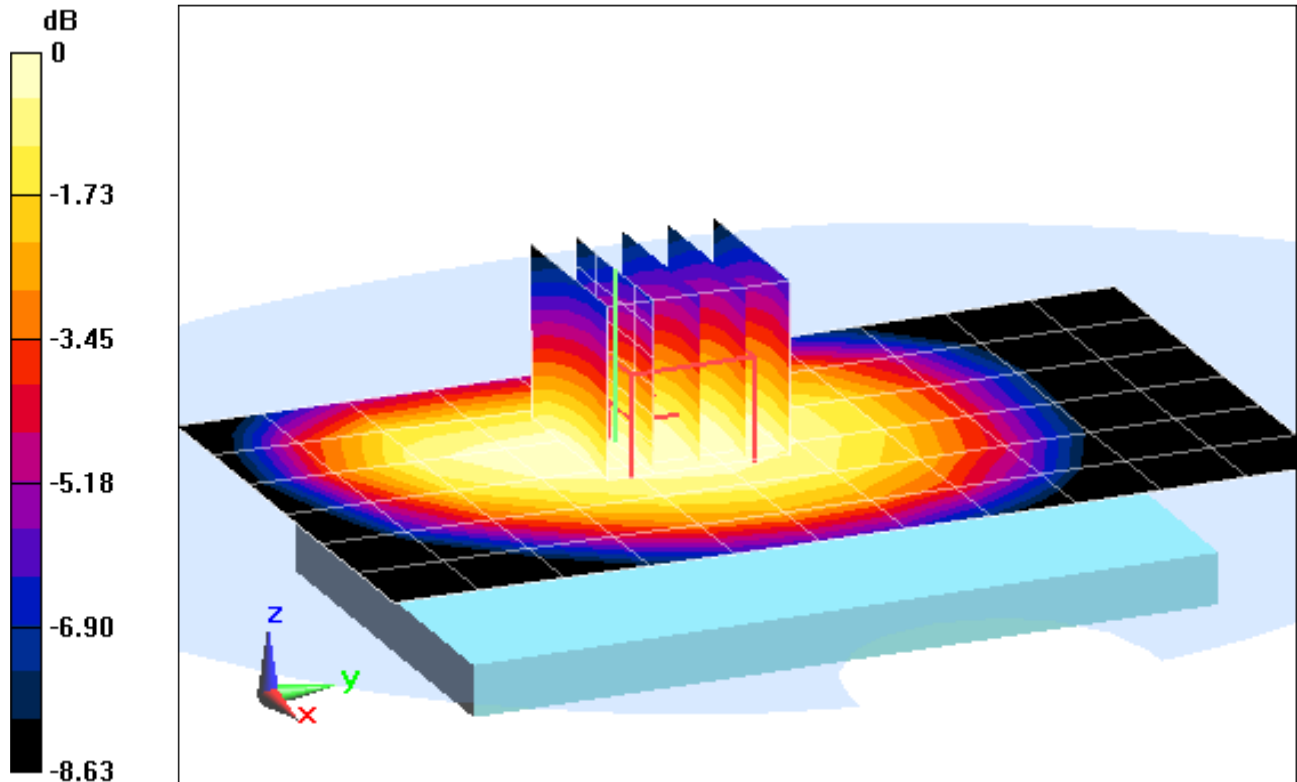

0 dB = 0.471 mW/g = -6.54 dB mW/g

PCTEST ENGINEERING LABORATORY, INC.

DUT: ZNFE970; Type: Portable Handset; Serial: 2G/3G SAR#1

Communication System: WCDMA850; Frequency: 836.6 MHz; Duty Cycle: 1:1

Medium: 835 Body Medium parameters used (interpolated):

$f = 836.6 \text{ MHz}$; $\sigma = 0.977 \text{ mho/m}$; $\epsilon_r = 52.604$; $\rho = 1000 \text{ kg/m}^3$

Phantom section: Flat Section; Space: 1.0 cm

Test Date: 07-09-2012; Ambient Temp: 24.9°C; Tissue Temp: 23.3C

Probe: ES3DV3 - SN3258; ConvF(6.06, 6.06, 6.06); Calibrated: 2/21/2012;

Sensor-Surface: 4mm (Mechanical Surface Detection)

Electronics: DAE4 Sn1272; Calibrated: 1/18/2012

Phantom: SAM Main; Type: SAM 4.0; Serial: TP-1406

Measurement SW: DASY4, Version 4.7 (80); SEMCAD X Version 14.6.5 (6469)

Mode: WCDMA 850, Body SAR, Bottom Edge, Mid.ch

Area Scan (9x7x1): Measurement grid: dx=5mm, dy=15mm

Zoom Scan (5x5x7)/Cube 0: Measurement grid: dx=8mm, dy=8mm, dz=5mm

Reference Value = 14.451 V/m; Power Drift = -0.12 dB

Peak SAR (extrapolated) = 0.266 mW/g

SAR(1 g) = 0.186 mW/g; SAR(10 g) = 0.121 mW/g

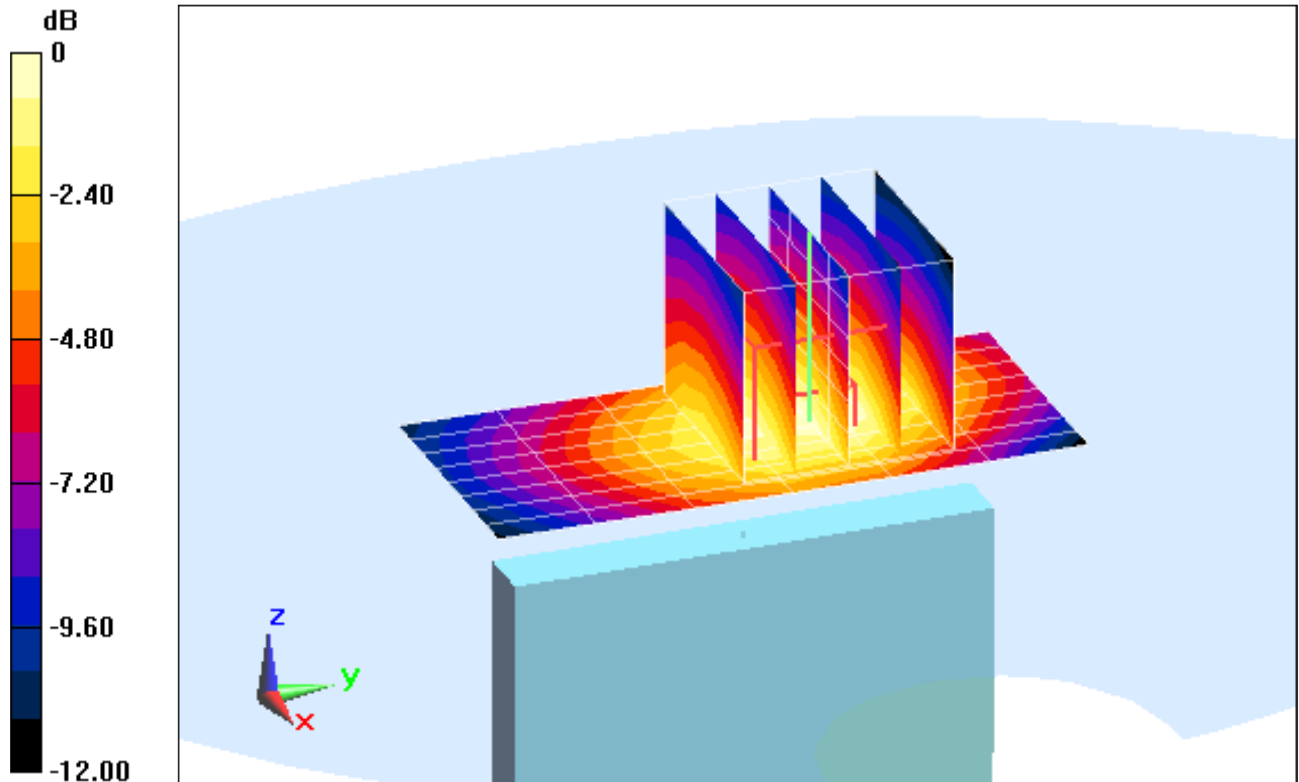

0 dB = 0.200 mW/g = -13.98 dB mW/g

PCTEST ENGINEERING LABORATORY, INC.

DUT: ZNFE970; Type: Portable Handset; Serial: 2G/3G SAR#1

Communication System: WCDMA850; Frequency: 836.6 MHz; Duty Cycle: 1:1

Medium: 835 Body Medium parameters used (interpolated):

$f = 836.6 \text{ MHz}$; $\sigma = 0.977 \text{ mho/m}$; $\epsilon_r = 52.604$; $\rho = 1000 \text{ kg/m}^3$

Phantom section: Flat Section; Space: 1.0 cm

Test Date: 07-09-2012; Ambient Temp: 24.9°C; Tissue Temp: 23.3C

Probe: ES3DV3 - SN3258; ConvF(6.06, 6.06, 6.06); Calibrated: 2/21/2012;

Sensor-Surface: 4mm (Mechanical Surface Detection)

Electronics: DAE4 Sn1272; Calibrated: 1/18/2012

Phantom: SAM Main; Type: SAM 4.0; Serial: TP-1406

Measurement SW: DASY4, Version 4.7 (80); SEMCAD X Version 14.6.5 (6469)

Mode: WCDMA 850, Body SAR, Left Edge, Mid.ch

Area Scan (9x13x1): Measurement grid: dx=5mm, dy=15mm

Zoom Scan (5x5x7)/Cube 0: Measurement grid: dx=8mm, dy=8mm, dz=5mm

Reference Value = 26.633 V/m; Power Drift = 0.05 dB

Peak SAR (extrapolated) = 0.870 mW/g

SAR(1 g) = 0.630 mW/g; SAR(10 g) = 0.439 mW/g

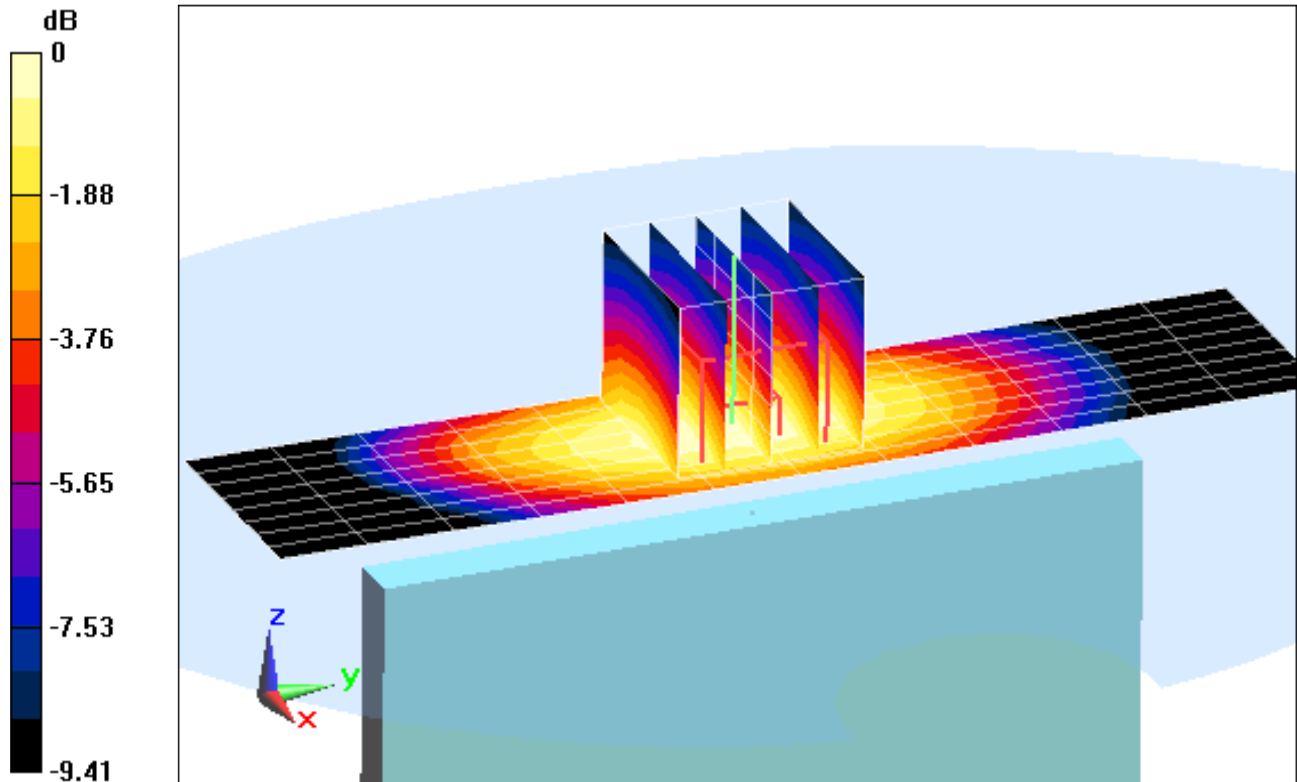

0 dB = 0.675 mW/g = -3.41 dB mW/g

PCTEST ENGINEERING LABORATORY, INC.

DUT: ZNFE970; Type: Portable Handset; Serial: LTE SAR#1

Communication System: LTE BAND 5; Frequency: 844 MHz; Duty Cycle: 1:1
Medium: 835 Body Medium parameters used (interpolated):
 $f = 844 \text{ MHz}$; $\sigma = 0.985 \text{ mho/m}$; $\epsilon_r = 52.668$; $\rho = 1000 \text{ kg/m}^3$
Phantom section: Flat Section; Space: 1.0 cm

Test Date: 07-09-2012; Ambient Temp: 24.9°C; Tissue Temp: 23.3C

Probe: ES3DV3 - SN3258; ConvF(6.06, 6.06, 6.06); Calibrated: 2/21/2012;
Sensor-Surface: 4mm (Mechanical Surface Detection)
Electronics: DAE4 Sn1272; Calibrated: 1/18/2012
Phantom: SAM Main; Type: SAM 4.0; Serial: TP-1406

Measurement SW: DASY4, Version 4.7 (80); SEMCAD X Version 14.6.5 (6469)

Mode: LTE Band 5 (Cell), Body SAR, Back side, High.ch
10 MHz Bandwidth, QPSK, 1 RB, 49 RB Offset

Area Scan (8x11x1): Measurement grid: dx=15mm, dy=15mm

Zoom Scan (5x5x7)/Cube 0: Measurement grid: dx=8mm, dy=8mm, dz=5mm

Reference Value = 25.983 V/m; Power Drift = 0.04 dB

Peak SAR (extrapolated) = 0.816 mW/g

SAR(1 g) = 0.638 mW/g; SAR(10 g) = 0.481 mW/g

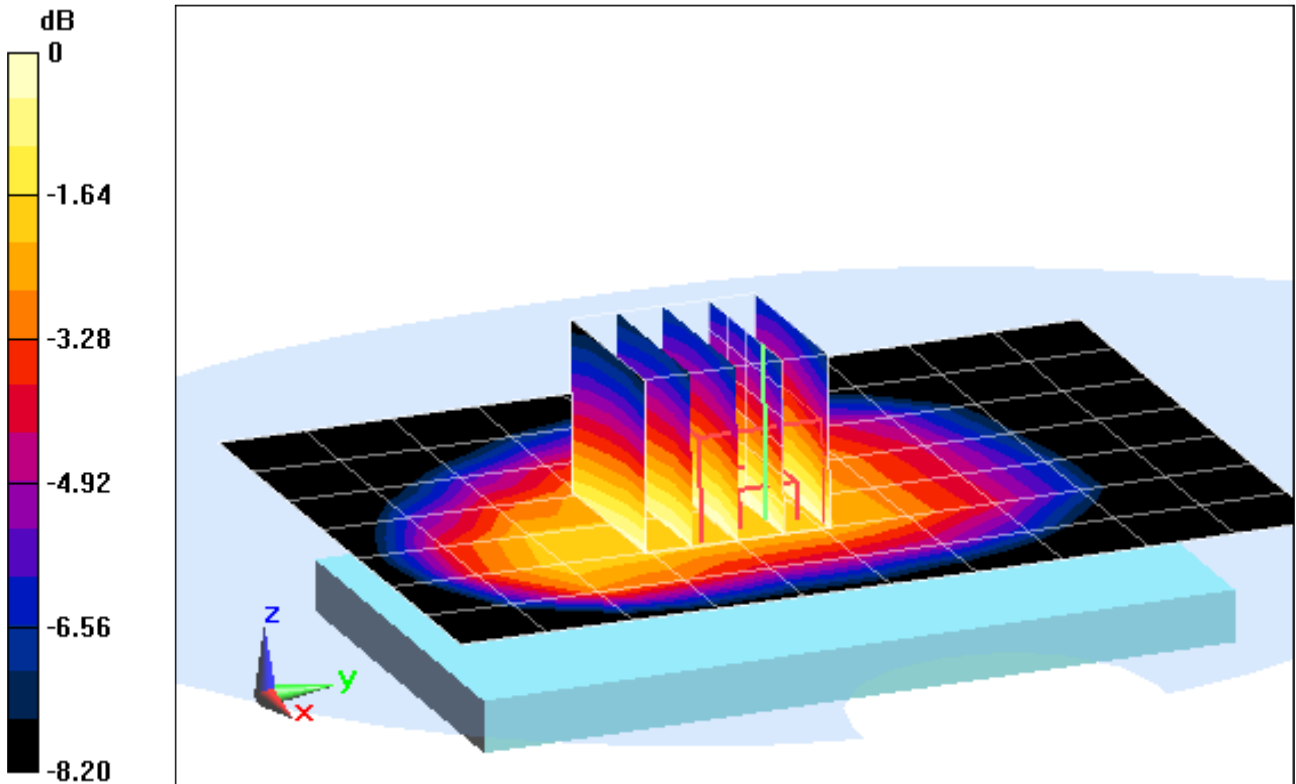

0 dB = 0.667 mW/g = -3.52 dB mW/g

PCTEST ENGINEERING LABORATORY, INC.

DUT: ZNFE970; Type: Portable Handset; Serial: LTE SAR#1

Communication System: LTE BAND 5; Frequency: 844 MHz; Duty Cycle: 1:1

Medium: 835 Body Medium parameters used (interpolated):

$f = 844 \text{ MHz}$; $\sigma = 0.985 \text{ mho/m}$; $\epsilon_r = 52.668$; $\rho = 1000 \text{ kg/m}^3$

Phantom section: Flat Section; Space: 1.0 cm

Test Date: 07-09-2012; Ambient Temp: 24.9°C; Tissue Temp: 23.3C

Probe: ES3DV3 - SN3258; ConvF(6.06, 6.06, 6.06); Calibrated: 2/21/2012;

Sensor-Surface: 4mm (Mechanical Surface Detection)

Electronics: DAE4 Sn1272; Calibrated: 1/18/2012

Phantom: SAM Main; Type: SAM 4.0; Serial: TP-1406

Measurement SW: DASY4, Version 4.7 (80); SEMCAD X Version 14.6.5 (6469)

Mode: LTE Band 5 (Cell), Body SAR, Front side, High.ch
10 MHz Bandwidth, QPSK, 1 RB, 49 RB Offset

Area Scan (8x11x1): Measurement grid: dx=15mm, dy=15mm

Zoom Scan (5x5x7)/Cube 0: Measurement grid: dx=8mm, dy=8mm, dz=5mm

Reference Value = 24.111 V/m; Power Drift = -0.01 dB

Peak SAR (extrapolated) = 0.690 mW/g

SAR(1 g) = 0.539 mW/g; SAR(10 g) = 0.414 mW/g

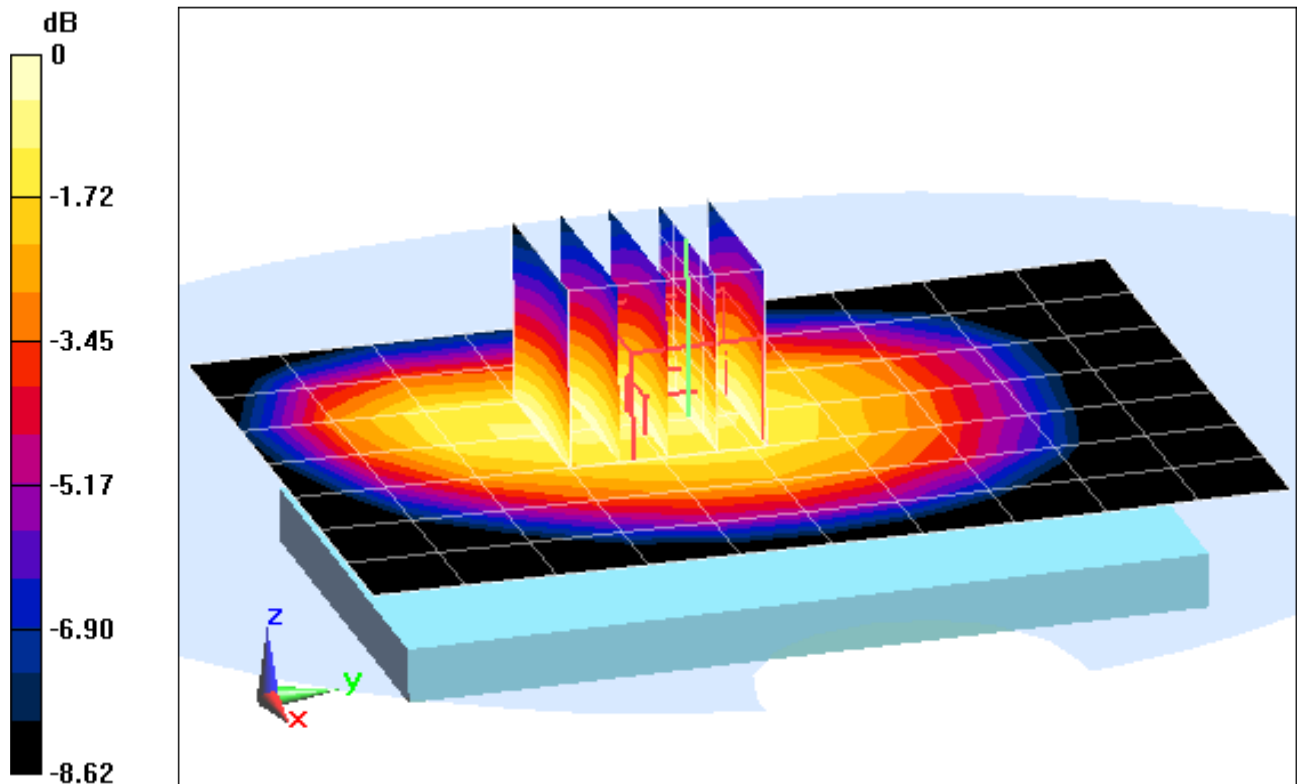

0 dB = 0.563 mW/g = -4.99 dB mW/g

PCTEST ENGINEERING LABORATORY, INC.

DUT: ZNFE970; Type: Portable Handset; Serial: LTE SAR#1

Communication System: LTE BAND 5; Frequency: 844 MHz; Duty Cycle: 1:1
Medium: 835 Body Medium parameters used (interpolated):
 $f = 844 \text{ MHz}$; $\sigma = 0.985 \text{ mho/m}$; $\epsilon_r = 52.668$; $\rho = 1000 \text{ kg/m}^3$
Phantom section: Flat Section; Space: 1.0 cm

Test Date: 07-09-2012; Ambient Temp: 24.9°C; Tissue Temp: 23.3C

Probe: ES3DV3 - SN3258; ConvF(6.06, 6.06, 6.06); Calibrated: 2/21/2012;
Sensor-Surface: 4mm (Mechanical Surface Detection)
Electronics: DAE4 Sn1272; Calibrated: 1/18/2012
Phantom: SAM Main; Type: SAM 4.0; Serial: TP-1406

Measurement SW: DASY4, Version 4.7 (80); SEMCAD X Version 14.6.5 (6469)

Mode: LTE Band 5 (Cell), Body SAR, Bottom Edge, High.ch
10 MHz Bandwidth, QPSK, 1 RB, 49 RB Offset

Area Scan (5x7x1): Measurement grid: dx=15mm, dy=15mm

Zoom Scan (5x5x7)/Cube 0: Measurement grid: dx=8mm, dy=8mm, dz=5mm

Reference Value = 16.730 V/m; Power Drift = 0.10 dB

Peak SAR (extrapolated) = 0.365 mW/g

SAR(1 g) = 0.257 mW/g; SAR(10 g) = 0.168 mW/g

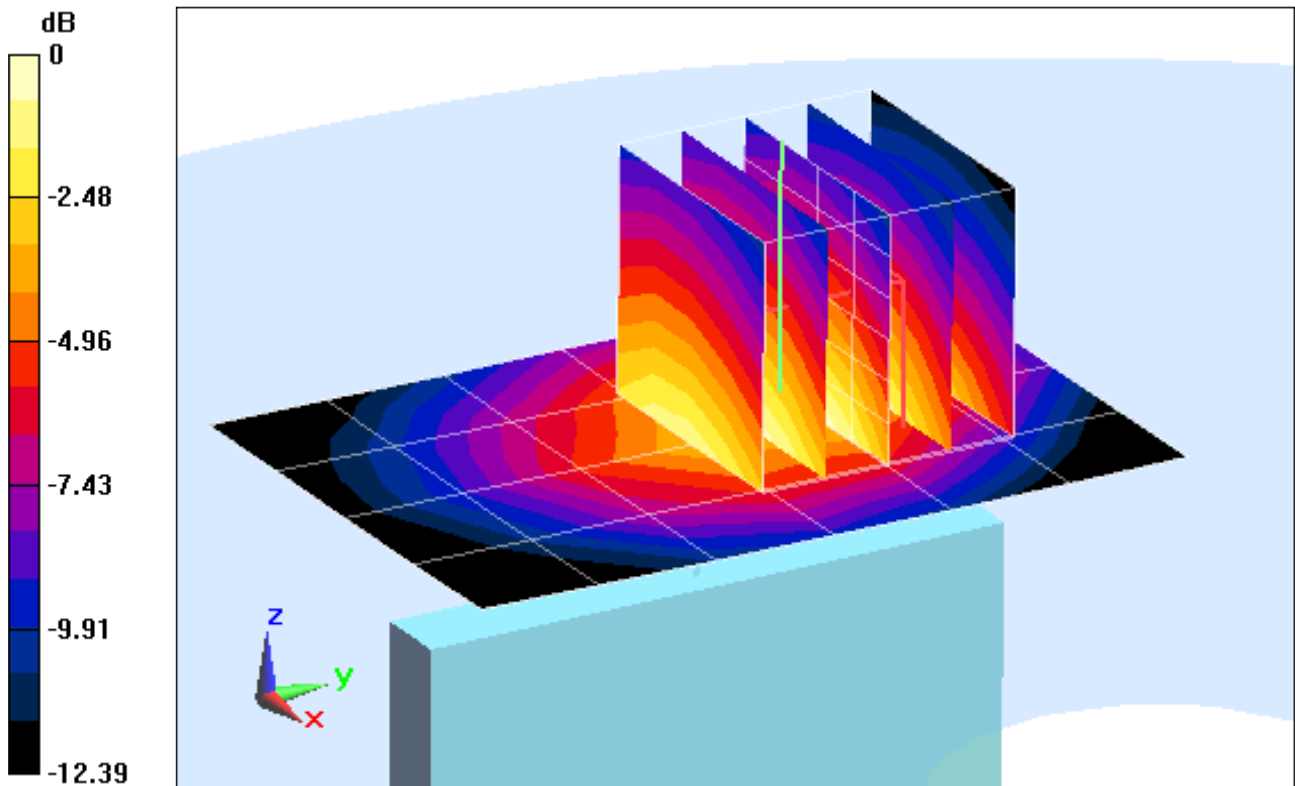

0 dB = 0.269 mW/g = -11.40 dB mW/g

PCTEST ENGINEERING LABORATORY, INC.

DUT: ZNFE970; Type: Portable Handset; Serial: LTE SAR#1

Communication System: LTE BAND 5; Frequency: 844 MHz; Duty Cycle: 1:1
Medium: 835 Body Medium parameters used (interpolated):
 $f = 844 \text{ MHz}$; $\sigma = 0.985 \text{ mho/m}$; $\epsilon_r = 52.668$; $\rho = 1000 \text{ kg/m}^3$
Phantom section: Flat Section; Space: 1.0 cm

Test Date: 07-09-2012; Ambient Temp: 24.9°C; Tissue Temp: 23.3C

Probe: ES3DV3 - SN3258; ConvF(6.06, 6.06, 6.06); Calibrated: 2/21/2012;
Sensor-Surface: 4mm (Mechanical Surface Detection)
Electronics: DAE4 Sn1272; Calibrated: 1/18/2012
Phantom: SAM Main; Type: SAM 4.0; Serial: TP-1406

Measurement SW: DASY4, Version 4.7 (80); SEMCAD X Version 14.6.5 (6469)

Mode: LTE (Band 5 Cell), Body SAR, Left Edge, High.ch
10 MHz Bandwidth, QPSK, 1 RB, 49 RB Offset

Area Scan (5x13x1): Measurement grid: dx=15mm, dy=15mm

Zoom Scan (5x5x7)/Cube 0: Measurement grid: dx=8mm, dy=8mm, dz=5mm

Reference Value = 28.100 V/m; Power Drift = 0.07 dB

Peak SAR (extrapolated) = 1.008 mW/g

SAR(1 g) = 0.726 mW/g; SAR(10 g) = 0.502 mW/g

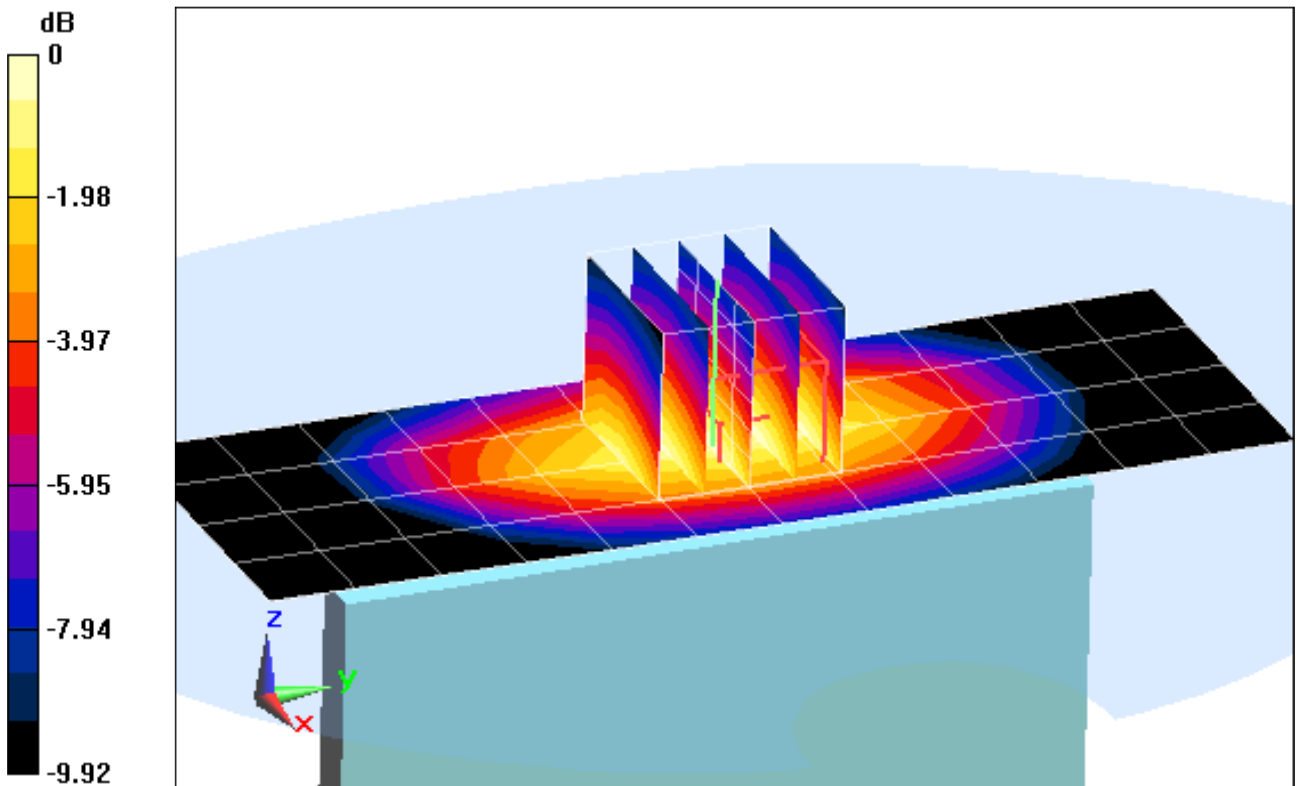

0 dB = 0.772 mW/g = -2.25 dB mW/g

PCTEST ENGINEERING LABORATORY, INC.

DUT: ZNFE970; Type: Portable Handset; Serial: LTE SAR #1

Communication System: LTE RF; Frequency: 1715 MHz; Duty Cycle: 1:1

Medium: 1750 Body Medium parameters used (interpolated):

$f = 1715 \text{ MHz}$; $\sigma = 1.414 \text{ mho/m}$; $\epsilon_r = 51.894$; $\rho = 1000 \text{ kg/m}^3$

Phantom section: Flat Section; Space: 1.0 cm

Test Date: 07-06-2012; Ambient Temp: 23.8°C; Tissue Temp: 22.9°C

Probe: ES3DV2 - SN3022; ConvF(4.64, 4.64, 4.64); Calibrated: 8/25/2011;

Sensor-Surface: 4mm (Mechanical Surface Detection)

Electronics: DAE4 Sn665; Calibrated: 4/19/2012

Phantom: SAM Sub Dasy B; Type: SAM 5.0; Serial: TP-1626

Measurement SW: DASY4, Version 4.7 (80); SEMCAD X Version 14.6.5 (6469)

Mode: LTE Band 4 (AWS), Body SAR, Back side, Low.ch

10 MHz Bandwidth, QPSK, 1 RB, 49 RB Offset

Area Scan (7x10x1): Measurement grid: dx=15mm, dy=15mm

Zoom Scan (5x5x7)/Cube 0: Measurement grid: dx=8mm, dy=8mm, dz=5mm

Reference Value = 30.911 V/m; Power Drift = 0.03 dB

Peak SAR (extrapolated) = 1.980 mW/g

SAR(1 g) = 1.22 mW/g; SAR(10 g) = 0.749 mW/g

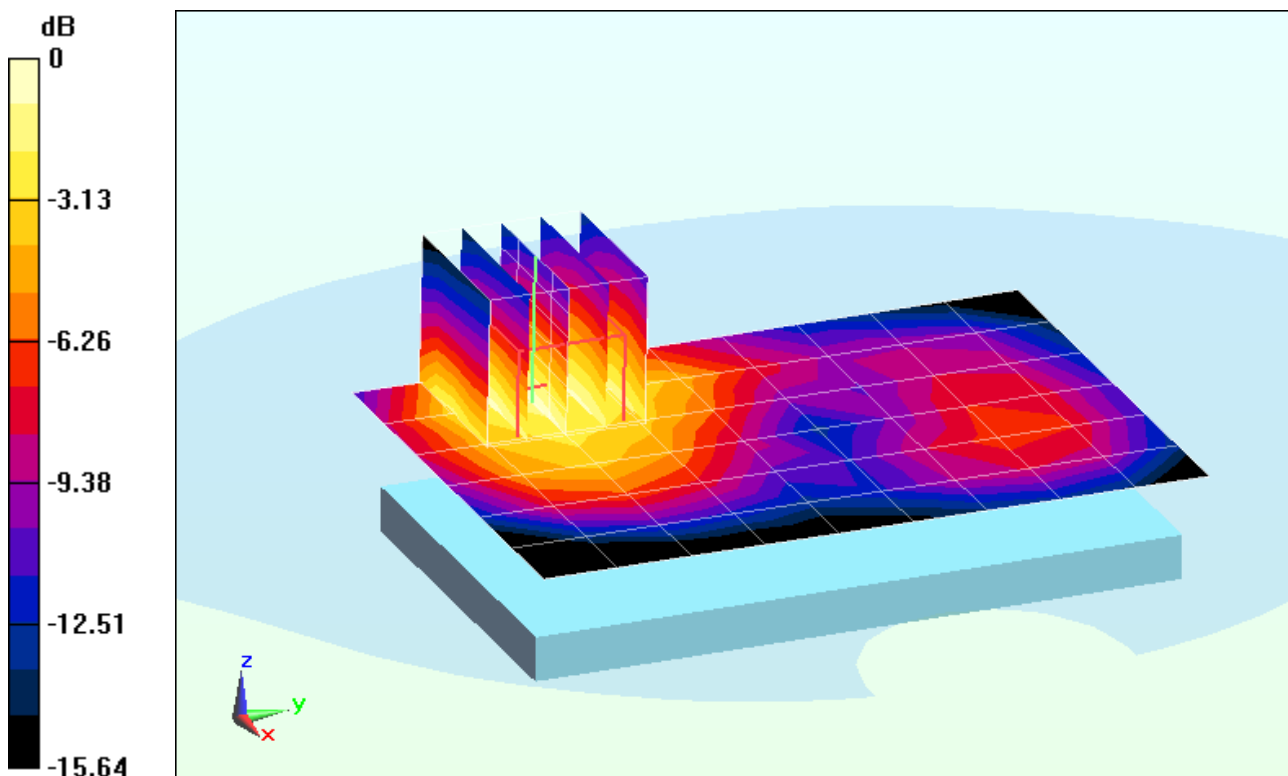

0 dB = 1.32 mW/g = 2.41 dB mW/g

PCTEST ENGINEERING LABORATORY, INC.

DUT: ZNFE970; Type: Portable Handset; Serial: LTE SAR #1

Communication System: LTE RF; Frequency: 1715 MHz; Duty Cycle: 1:1

Medium: 1750 Body Medium parameters used (interpolated):

$f = 1715 \text{ MHz}$; $\sigma = 1.414 \text{ mho/m}$; $\epsilon_r = 51.894$; $\rho = 1000 \text{ kg/m}^3$

Phantom section: Flat Section; Space: 1.0 cm

Test Date: 07-06-2012; Ambient Temp: 23.8°C; Tissue Temp: 22.9°C

Probe: ES3DV2 - SN3022; ConvF(4.64, 4.64, 4.64); Calibrated: 8/25/2011;

Sensor-Surface: 4mm (Mechanical Surface Detection)

Electronics: DAE4 Sn665; Calibrated: 4/19/2012

Phantom: SAM Sub Dasy B; Type: SAM 5.0; Serial: TP-1626

Measurement SW: DASY4, Version 4.7 (80); SEMCAD X Version 14.6.5 (6469)

**Mode: LTE Band 4 (AWS), Body SAR, Front side, Low.ch,
10 MHz Bandwidth, QPSK, 1 RB, 0 RB Offset**

Area Scan (7x10x1): Measurement grid: dx=15mm, dy=15mm

Zoom Scan (5x5x7)/Cube 0: Measurement grid: dx=8mm, dy=8mm, dz=5mm

Reference Value = 21.393 V/m; Power Drift = -0.04 dB

Peak SAR (extrapolated) = 1.024 mW/g

SAR(1 g) = 0.640 mW/g; SAR(10 g) = 0.407 mW/g

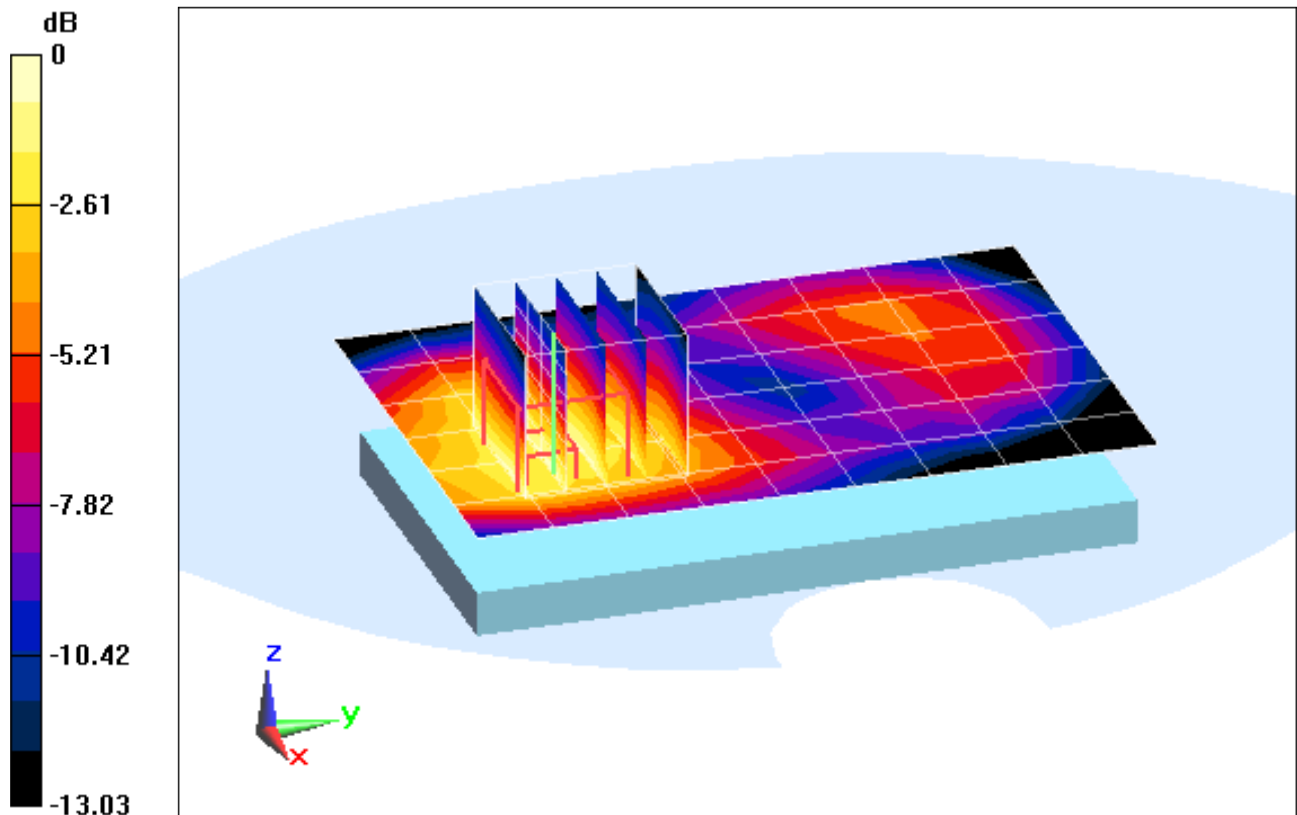

0 dB = 0.682 mW/g = -3.32 dB mW/g

PCTEST ENGINEERING LABORATORY, INC.

DUT: ZNFE970; Type: Portable Handset; Serial: LTE SAR #1

Communication System: LTE RF; Frequency: 1715 MHz; Duty Cycle: 1:1

Medium: 1750 Body Medium parameters used (interpolated):

$f = 1715 \text{ MHz}$; $\sigma = 1.414 \text{ mho/m}$; $\epsilon_r = 51.894$; $\rho = 1000 \text{ kg/m}^3$

Phantom section: Flat Section; Space: 1.0 cm

Test Date: 07-06-2012; Ambient Temp: 23.8°C; Tissue Temp: 22.9°C

Probe: ES3DV2 - SN3022; ConvF(4.64, 4.64, 4.64); Calibrated: 8/25/2011;

Sensor-Surface: 4mm (Mechanical Surface Detection)

Electronics: DAE4 Sn665; Calibrated: 4/19/2012

Phantom: SAM Sub Dasy B; Type: SAM 5.0; Serial: TP-1626

Measurement SW: DASY4, Version 4.7 (80); SEMCAD X Version 14.6.5 (6469)

Mode: LTE Band 4 (AWS), Body SAR, Bottom Edge, Low.ch
10 MHz Bandwidth, QPSK, 1 RB, 49 RB Offset

Area Scan (5x7x1): Measurement grid: dx=15mm, dy=15mm

Zoom Scan (5x5x7)/Cube 0: Measurement grid: dx=8mm, dy=8mm, dz=5mm

Reference Value = 18.429 V/m; Power Drift = 0.09 dB

Peak SAR (extrapolated) = 0.740 mW/g

SAR(1 g) = 0.472 mW/g; SAR(10 g) = 0.285 mW/g

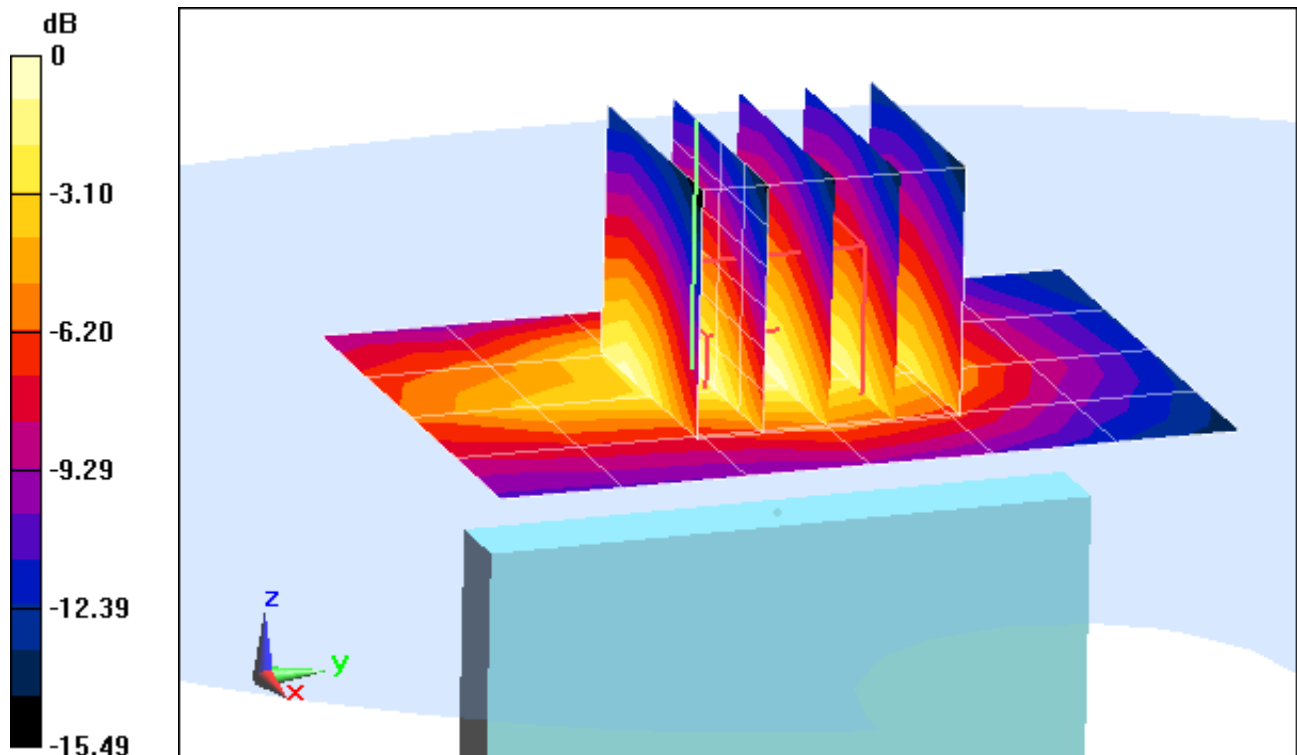

0 dB = 0.511 mW/g = -5.83 dB mW/g

PCTEST ENGINEERING LABORATORY, INC.

DUT: ZNFE970; Type: Portable Handset; Serial: LTE SAR #1

Communication System: LTE RF; Frequency: 1715 MHz; Duty Cycle: 1:1

Medium: 1750 Body Medium parameters used (interpolated):

$f = 1715 \text{ MHz}$; $\sigma = 1.414 \text{ mho/m}$; $\epsilon_r = 51.894$; $\rho = 1000 \text{ kg/m}^3$

Phantom section: Flat Section; Space: 1.0 cm

Test Date: 07-06-2012; Ambient Temp: 23.8°C; Tissue Temp: 22.9°C

Probe: ES3DV2 - SN3022; ConvF(4.64, 4.64, 4.64); Calibrated: 8/25/2011;

Sensor-Surface: 4mm (Mechanical Surface Detection)

Electronics: DAE4 Sn665; Calibrated: 4/19/2012

Phantom: SAM Sub Dasy B; Type: SAM 5.0; Serial: TP-1626

Measurement SW: DASY4, Version 4.7 (80); SEMCAD X Version 14.6.5 (6469)

Mode: LTE Band 4 (AWS), Body SAR, Right Edge, Low.ch
10 MHz Bandwidth, QPSK, 1 RB, 49 RB Offset

Area Scan (5x13x1): Measurement grid: dx=15mm, dy=15mm

Zoom Scan (5x5x7)/Cube 0: Measurement grid: dx=8mm, dy=8mm, dz=5mm

Reference Value = 19.346 V/m; Power Drift = -0.09 dB

Peak SAR (extrapolated) = 0.739 mW/g

SAR(1 g) = 0.463 mW/g; SAR(10 g) = 0.277 mW/g

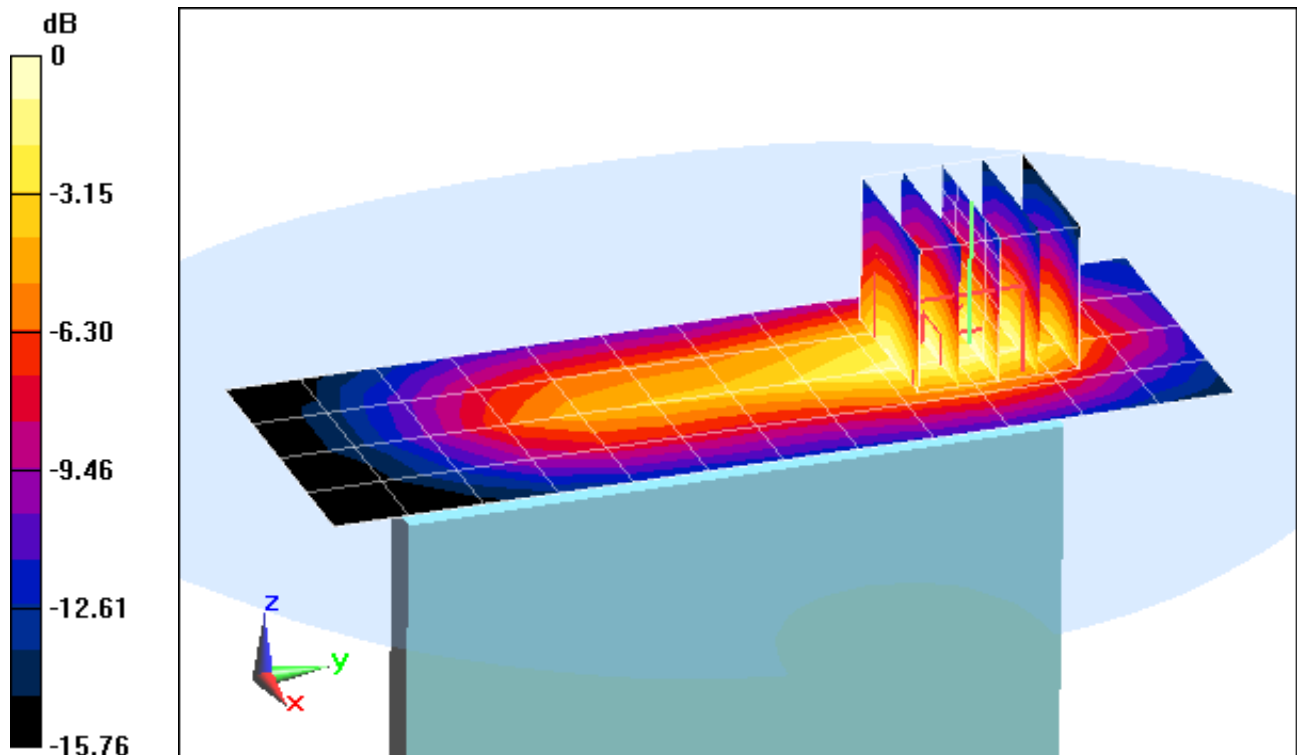

0 dB = 0.501 mW/g = -6.00 dB mW/g

PCTEST ENGINEERING LABORATORY, INC.

DUT: ZNFE970; Type: Portable Handset; Serial: 2G/3G SAR#1

Communication System: GSM1900 GPRS; 2 Tx slots; Frequency: 1880 MHz; Duty Cycle: 1:4.15

Medium: 1900 Body Medium parameters used:

$f = 1880 \text{ MHz}$; $\sigma = 1.489 \text{ mho/m}$; $\epsilon_r = 51.86$; $\rho = 1000 \text{ kg/m}^3$

Phantom section: Flat Section; Space: 1.0 cm

Test Date: 07-09-2012; Ambient Temp: 23.7°C; Tissue Temp: 24.8°C

Probe: ES3DV2 - SN3022; ConvF(4.41, 4.41, 4.41); Calibrated: 8/25/2011;

Sensor-Surface: 4mm (Mechanical Surface Detection)

Electronics: DAE4 Sn665; Calibrated: 4/19/2012

Phantom: SAM Sub Dasy B; Type: SAM 5.0; Serial: TP-1626

Measurement SW: DASY4, Version 4.7 (80); SEMCAD X Version 14.6.5 (6469)

Mode: GPRS 1900, Body SAR, Back side, Mid.ch, 2 Tx Slots

Area Scan (7x12x1): Measurement grid: dx=15mm, dy=15mm

Zoom Scan (5x5x7)/Cube 0: Measurement grid: dx=8mm, dy=8mm, dz=5mm

Reference Value = 19.056 V/m; Power Drift = -0.07 dB

Peak SAR (extrapolated) = 0.833 mW/g

SAR(1 g) = 0.522 mW/g; SAR(10 g) = 0.335 mW/g

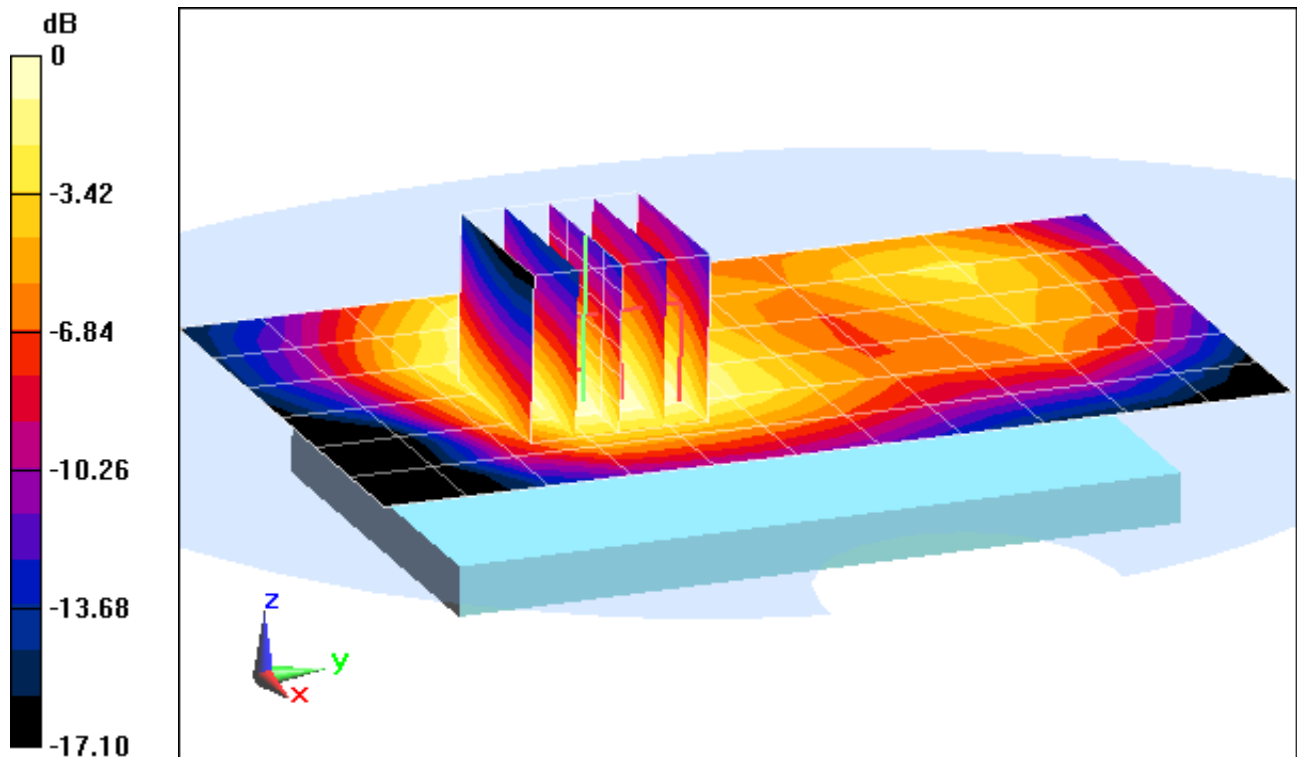

0 dB = 0.551 mW/g = -5.18 dB mW/g

PCTEST ENGINEERING LABORATORY, INC.

DUT: ZNFE970; Type: Portable Handset; Serial: 2G/3G SAR#1

Communication System: GSM1900 GPRS; 2 Tx slots; Frequency: 1880 MHz; Duty Cycle: 1:4.15

Medium: 1900 Body Medium parameters used:

$f = 1880 \text{ MHz}$; $\sigma = 1.489 \text{ mho/m}$; $\epsilon_r = 51.86$; $\rho = 1000 \text{ kg/m}^3$

Phantom section: Flat Section; Space: 1.0 cm

Test Date: 07-09-2012; Ambient Temp: 23.7°C; Tissue Temp: 24.8°C

Probe: ES3DV2 - SN3022; ConvF(4.41, 4.41, 4.41); Calibrated: 8/25/2011;

Sensor-Surface: 4mm (Mechanical Surface Detection)

Electronics: DAE4 Sn665; Calibrated: 4/19/2012

Phantom: SAM Sub Dasy B; Type: SAM 5.0; Serial: TP-1626

Measurement SW: DASY4, Version 4.7 (80); SEMCAD X Version 14.6.5 (6469)

Mode: GPRS 1900, Body SAR, Front side, Mid.ch, 2 Tx Slots

Area Scan (9x13x1): Measurement grid: dx=15mm, dy=15mm

Zoom Scan (5x5x7)/Cube 0: Measurement grid: dx=8mm, dy=8mm, dz=5mm

Reference Value = 16.955 V/m; Power Drift = -0.04 dB

Peak SAR (extrapolated) = 0.650 mW/g

SAR(1 g) = 0.392 mW/g; SAR(10 g) = 0.251 mW/g

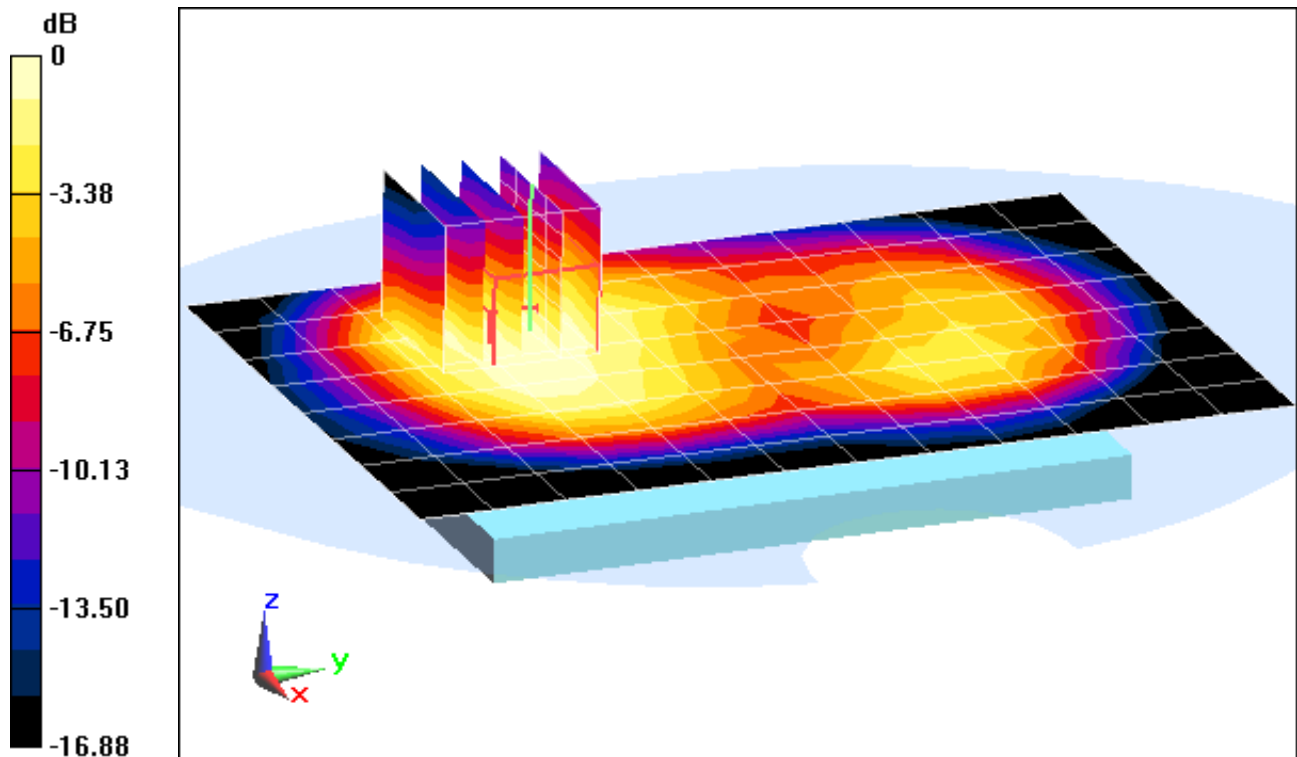

0 dB = 0.418 mW/g = -7.58 dB mW/g

PCTEST ENGINEERING LABORATORY, INC.

DUT: ZNFE970; Type: Portable Handset; Serial: 2G/3G SAR#1

Communication System: GSM1900 GPRS; 2 Tx slots; Frequency: 1880 MHz; Duty Cycle: 1:4.15

Medium: 1900 Body Medium parameters used:

$f = 1880 \text{ MHz}$; $\sigma = 1.489 \text{ mho/m}$; $\epsilon_r = 51.86$; $\rho = 1000 \text{ kg/m}^3$

Phantom section: Flat Section; Space: 1.0 cm

Test Date: 07-09-2012; Ambient Temp: 23.7°C; Tissue Temp: 24.8°C

Probe: ES3DV2 - SN3022; ConvF(4.41, 4.41, 4.41); Calibrated: 8/25/2011;

Sensor-Surface: 4mm (Mechanical Surface Detection)

Electronics: DAE4 Sn665; Calibrated: 4/19/2012

Phantom: SAM Sub Dasy B; Type: SAM 5.0; Serial: TP-1626

Measurement SW: DASY4, Version 4.7 (80); SEMCAD X Version 14.6.5 (6469)

Mode: GPRS 1900, Body SAR, Bottom Edge, Mid.ch, 2 Tx Slots

Area Scan (5x7x1): Measurement grid: dx=15mm, dy=15mm

Zoom Scan (5x5x7)/Cube 0: Measurement grid: dx=8mm, dy=8mm, dz=5mm

Reference Value = 11.318 V/m; Power Drift = 0.21 dB

Peak SAR (extrapolated) = 0.315 mW/g

SAR(1 g) = 0.200 mW/g; SAR(10 g) = 0.122 mW/g

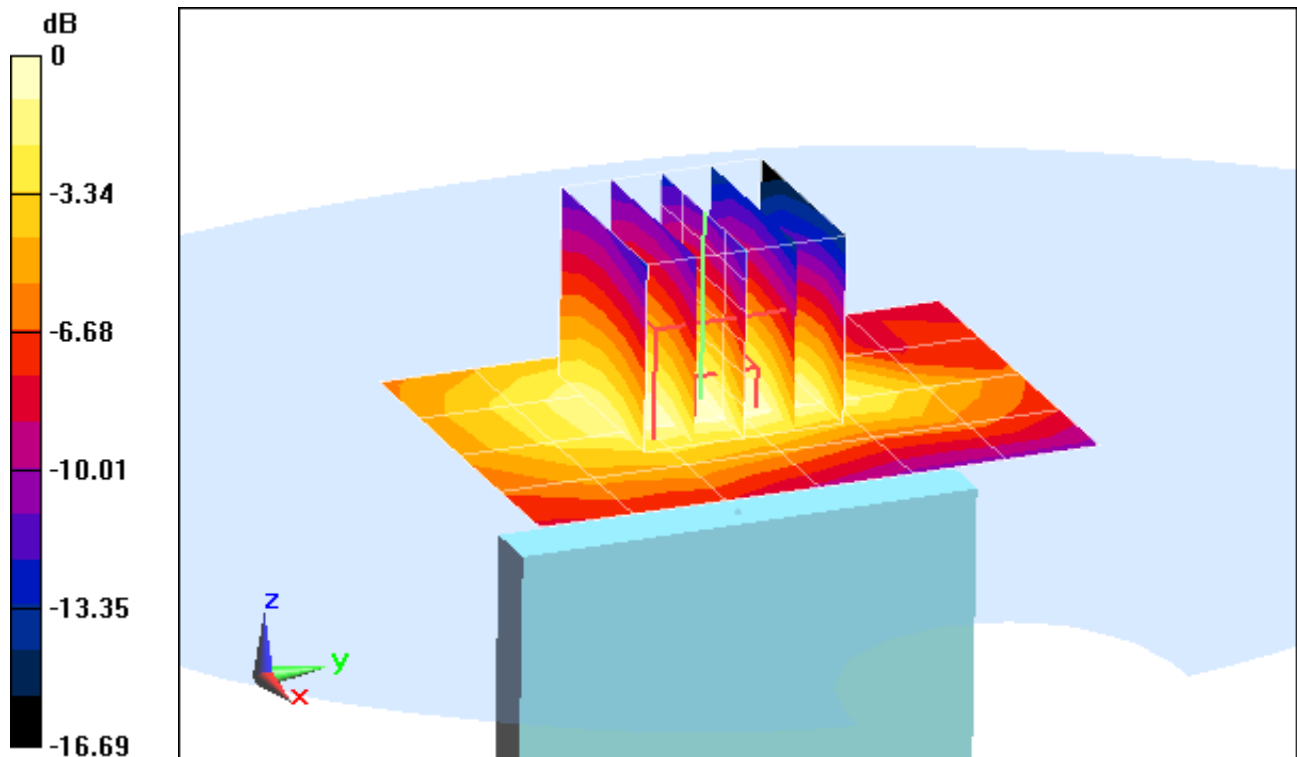

0 dB = 0.217 mW/g = -13.27 dB mW/g

PCTEST ENGINEERING LABORATORY, INC.

DUT: ZNFE970; Type: Portable Handset; Serial: 2G/3G SAR#1

Communication System: GSM1900 GPRS; 2 Tx slots; Frequency: 1880 MHz; Duty Cycle: 1:4.15

Medium: 1900 Body Medium parameters used:

$f = 1880 \text{ MHz}$; $\sigma = 1.489 \text{ mho/m}$; $\epsilon_r = 51.86$; $\rho = 1000 \text{ kg/m}^3$

Phantom section: Flat Section; Space: 1.0 cm

Test Date: 07-09-2012; Ambient Temp: 23.7°C; Tissue Temp: 24.8°C

Probe: ES3DV2 - SN3022; ConvF(4.41, 4.41, 4.41); Calibrated: 8/25/2011;

Sensor-Surface: 4mm (Mechanical Surface Detection)

Electronics: DAE4 Sn665; Calibrated: 4/19/2012

Phantom: SAM Sub Dasy B; Type: SAM 5.0; Serial: TP-1626

Measurement SW: DASY4, Version 4.7 (80); SEMCAD X Version 14.6.5 (6469)

Mode: GPRS 1900, Body SAR, Left Edge, Mid.ch, 2 Tx Slots

Area Scan (5x13x1): Measurement grid: dx=15mm, dy=15mm

Zoom Scan (5x5x7)/Cube 0: Measurement grid: dx=8mm, dy=8mm, dz=5mm

Reference Value = 15.450 V/m; Power Drift = 0.05 dB

Peak SAR (extrapolated) = 0.560 mW/g

SAR(1 g) = 0.360 mW/g; SAR(10 g) = 0.217 mW/g

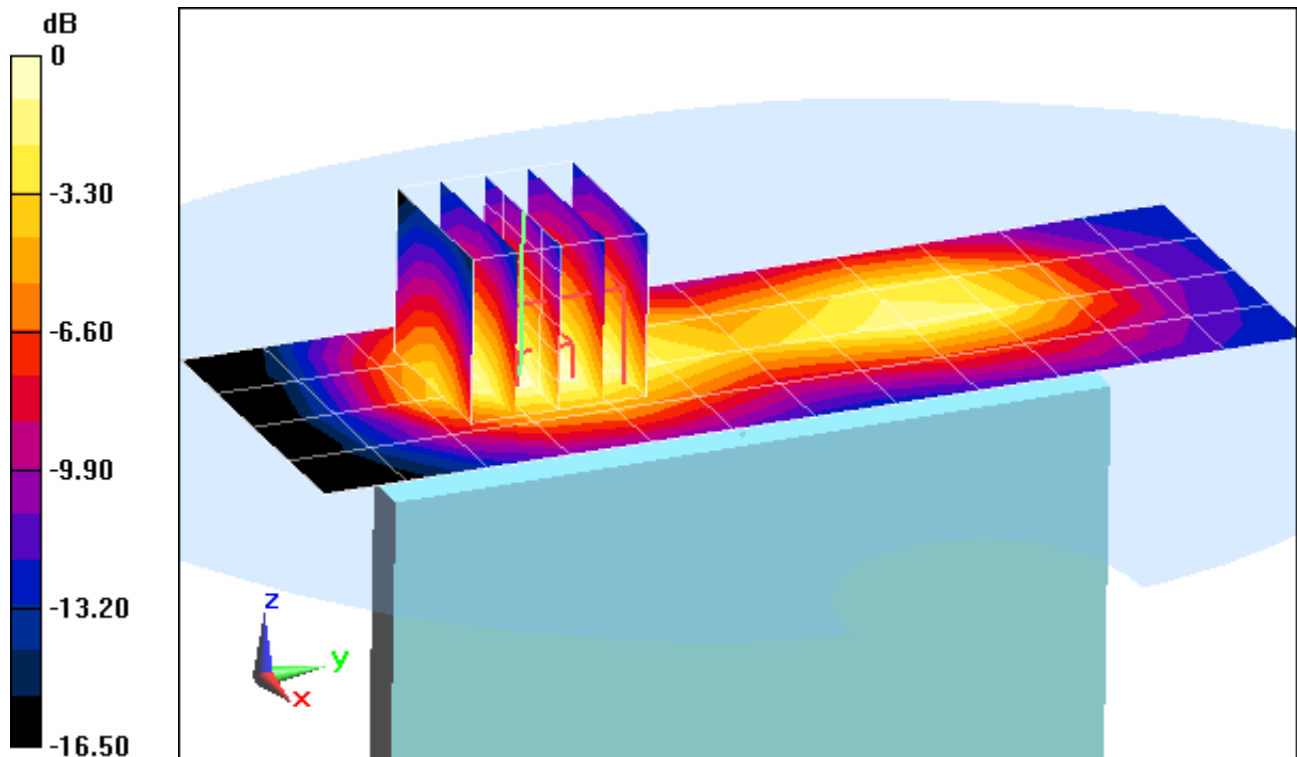

0 dB = 0.391 mW/g = -8.16 dB mW/g

PCTEST ENGINEERING LABORATORY, INC.

DUT: ZNFE970; Type: Portable Handset; Serial: 2G/3G SAR#1

Communication System: WCDMA1900; Frequency: 1880 MHz; Duty Cycle: 1:1

Medium: 1900 Body Medium parameters used:

$f = 1880 \text{ MHz}$; $\sigma = 1.489 \text{ mho/m}$; $\epsilon_r = 51.86$; $\rho = 1000 \text{ kg/m}^3$

Phantom section: Flat Section; Space: 1.0 cm

Test Date: 07-09-2012; Ambient Temp: 23.7°C; Tissue Temp: 24.8°C

Probe: ES3DV2 - SN3022; ConvF(4.41, 4.41, 4.41); Calibrated: 8/25/2011;

Sensor-Surface: 4mm (Mechanical Surface Detection)

Electronics: DAE4 Sn665; Calibrated: 4/19/2012

Phantom: SAM Sub Dasy B; Type: SAM 5.0; Serial: TP-1626

Measurement SW: DASY4, Version 4.7 (80); SEMCAD X Version 14.6.5 (6469)

Mode: WCDMA 1900, Body SAR, Back side, Mid.ch

Area Scan (9x13x1): Measurement grid: dx=15mm, dy=15mm

Zoom Scan (5x5x7)/Cube 0: Measurement grid: dx=8mm, dy=8mm, dz=5mm

Reference Value = 20.378 V/m; Power Drift = -0.02 dB

Peak SAR (extrapolated) = 0.910 mW/g

SAR(1 g) = 0.575 mW/g; SAR(10 g) = 0.367 mW/g

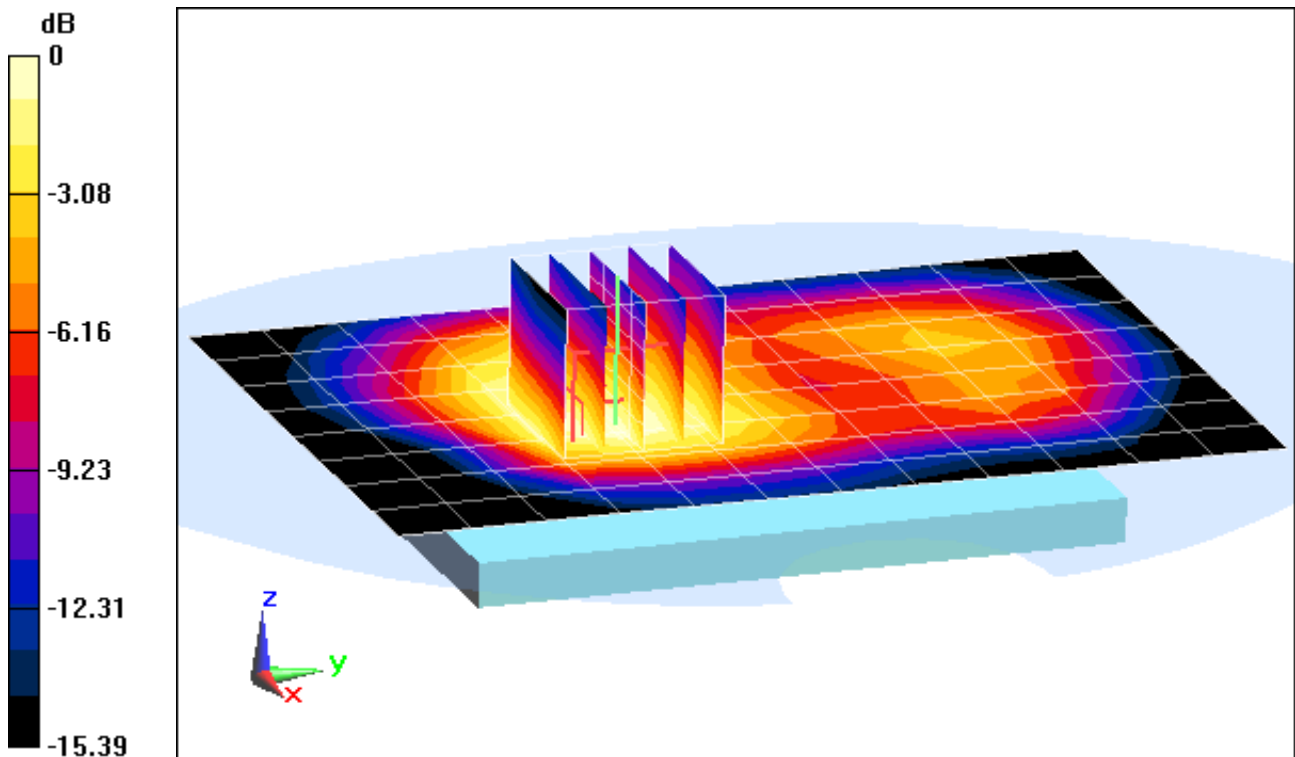

0 dB = 0.610 mW/g = -4.29 dB mW/g

PCTEST ENGINEERING LABORATORY, INC.

DUT: ZNFE970; Type: Portable Handset; Serial: 2G/3G SAR#1

Communication System: WCDMA1900; Frequency: 1880 MHz; Duty Cycle: 1:1

Medium: 1900 Body Medium parameters used:

$f = 1880 \text{ MHz}$; $\sigma = 1.489 \text{ mho/m}$; $\epsilon_r = 51.86$; $\rho = 1000 \text{ kg/m}^3$

Phantom section: Flat Section; Space: 1.0 cm

Test Date: 07-09-2012; Ambient Temp: 23.7°C; Tissue Temp: 24.8°C

Probe: ES3DV2 - SN3022; ConvF(4.41, 4.41, 4.41); Calibrated: 8/25/2011;

Sensor-Surface: 4mm (Mechanical Surface Detection)

Electronics: DAE4 Sn665; Calibrated: 4/19/2012

Phantom: SAM Sub Dasy B; Type: SAM 5.0; Serial: TP-1626

Measurement SW: DASY4, Version 4.7 (80); SEMCAD X Version 14.6.5 (6469)

Mode: WCDMA 1900, Body SAR, Front side, Mid.ch

Area Scan (9x13x1): Measurement grid: dx=15mm, dy=15mm

Zoom Scan (5x5x7)/Cube 0: Measurement grid: dx=8mm, dy=8mm, dz=5mm

Reference Value = 17.610 V/m; Power Drift = -0.00 dB

Peak SAR (extrapolated) = 0.758 mW/g

SAR(1 g) = 0.432 mW/g; SAR(10 g) = 0.266 mW/g

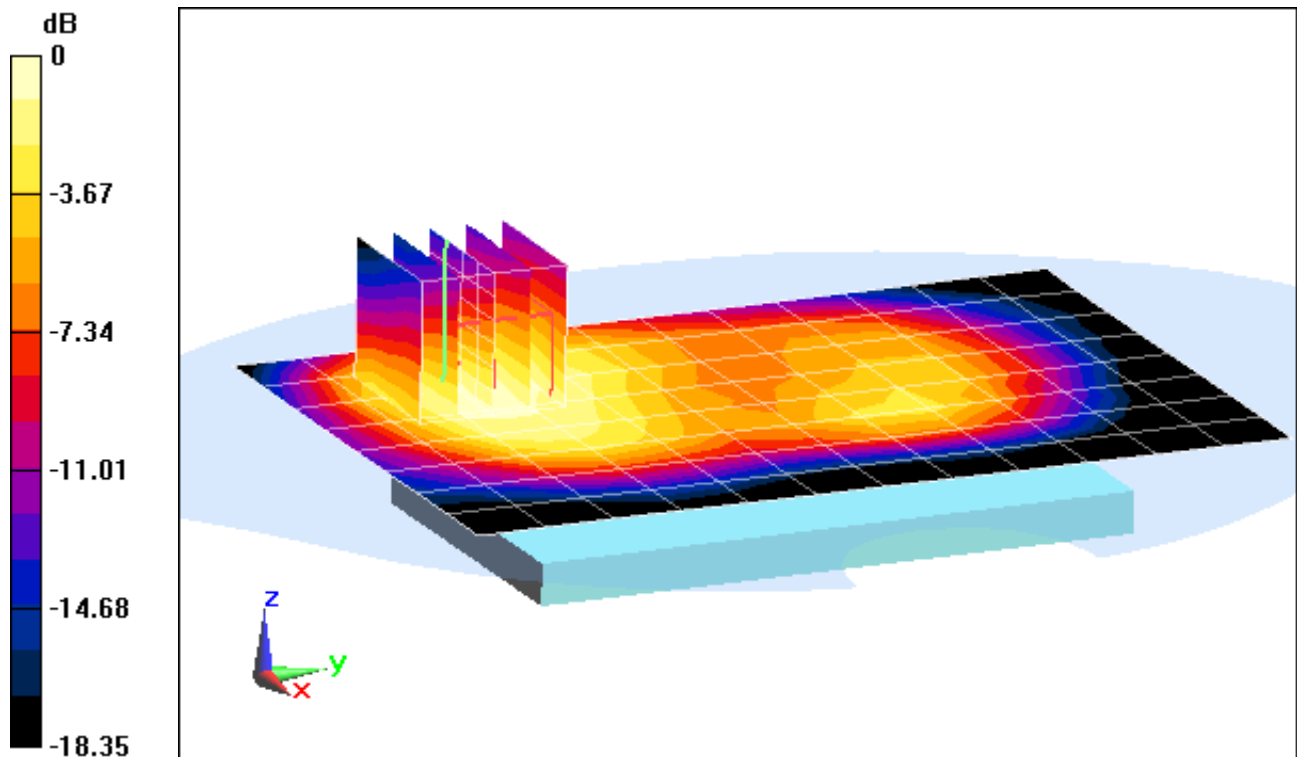

0 dB = 0.469 mW/g = -6.58 dB mW/g

PCTEST ENGINEERING LABORATORY, INC.

DUT: ZNFE970; Type: Portable Handset; Serial: 2G/3G SAR#1

Communication System: WCDMA1900; Frequency: 1880 MHz; Duty Cycle: 1:1

Medium: 1900 Body Medium parameters used:

$f = 1880 \text{ MHz}$; $\sigma = 1.489 \text{ mho/m}$; $\epsilon_r = 51.86$; $\rho = 1000 \text{ kg/m}^3$

Phantom section: Flat Section; Space: 1.0 cm

Test Date: 07-09-2012; Ambient Temp: 23.7°C; Tissue Temp: 24.8°C

Probe: ES3DV2 - SN3022; ConvF(4.41, 4.41, 4.41); Calibrated: 8/25/2011;

Sensor-Surface: 4mm (Mechanical Surface Detection)

Electronics: DAE4 Sn665; Calibrated: 4/19/2012

Phantom: SAM Sub Dasy B; Type: SAM 5.0; Serial: TP-1626

Measurement SW: DASY4, Version 4.7 (80); SEMCAD X Version 14.6.5 (6469)

Mode: WCDMA 1900, Body SAR, Bottom Edge, Mid.ch

Area Scan (9x7x1): Measurement grid: dx=5mm, dy=15mm

Zoom Scan (5x5x7)/Cube 0: Measurement grid: dx=8mm, dy=8mm, dz=5mm

Reference Value = 10.618 V/m; Power Drift = 0.08 dB

Peak SAR (extrapolated) = 0.239 mW/g

SAR(1 g) = 0.153 mW/g; SAR(10 g) = 0.094 mW/g

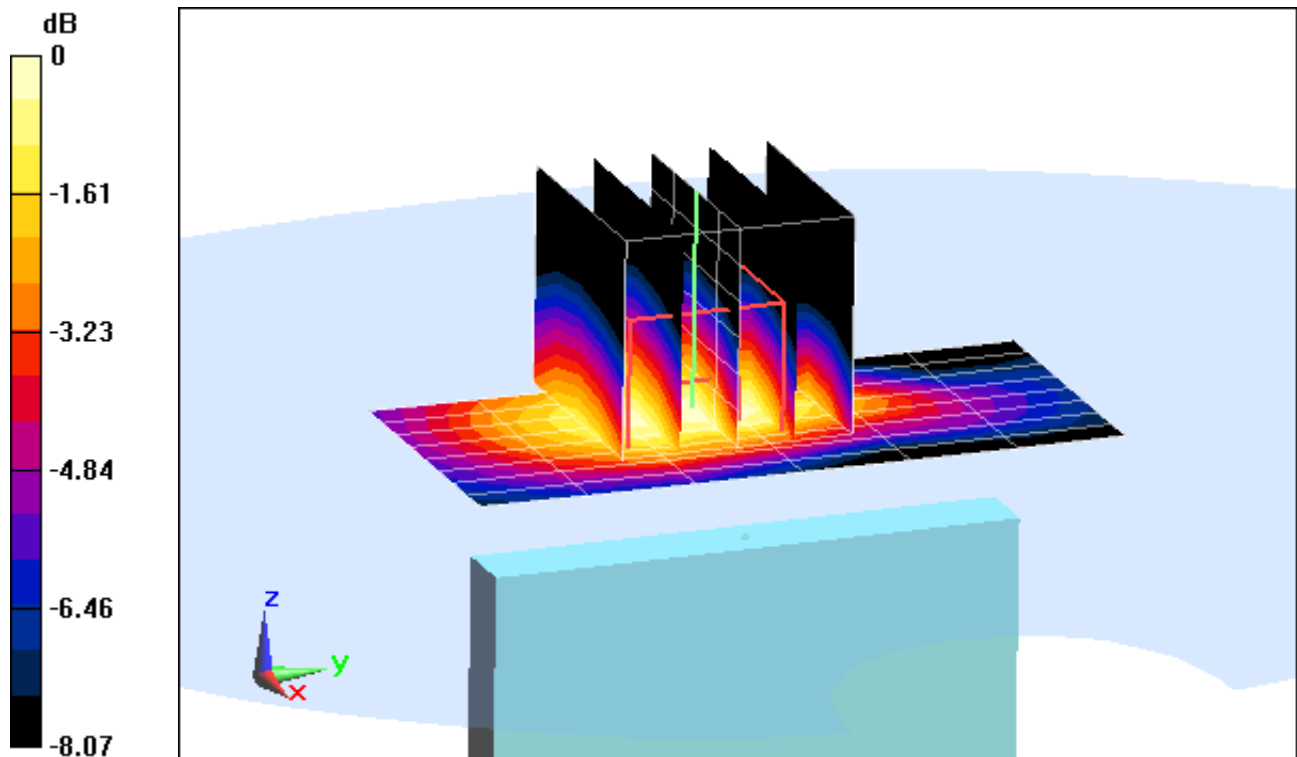

0 dB = 0.167 mW/g = -15.55 dB mW/g

PCTEST ENGINEERING LABORATORY, INC.

DUT: ZNFE970; Type: Portable Handset; Serial: 2G/3G SAR#1

Communication System: WCDMA1900; Frequency: 1880 MHz; Duty Cycle: 1:1

Medium: 1900 Body Medium parameters used:

$f = 1880 \text{ MHz}$; $\sigma = 1.489 \text{ mho/m}$; $\epsilon_r = 51.86$; $\rho = 1000 \text{ kg/m}^3$

Phantom section: Flat Section; Space: 1.0 cm

Test Date: 07-09-2012; Ambient Temp: 23.7°C; Tissue Temp: 24.8°C

Probe: ES3DV2 - SN3022; ConvF(4.41, 4.41, 4.41); Calibrated: 8/25/2011;

Sensor-Surface: 4mm (Mechanical Surface Detection)

Electronics: DAE4 Sn665; Calibrated: 4/19/2012

Phantom: SAM Sub Dasy B; Type: SAM 5.0; Serial: TP-1626

Measurement SW: DASYS4, Version 4.7 (80); SEMCAD X Version 14.6.5 (6469)

Mode: WCDMA 1900, Body SAR, Left Edge, Mid.ch

Area Scan (9x13x1): Measurement grid: dx=5mm, dy=15mm

Zoom Scan (5x5x7)/Cube 0: Measurement grid: dx=8mm, dy=8mm, dz=5mm

Reference Value = 13.146 V/m; Power Drift = 0.02 dB

Peak SAR (extrapolated) = 0.364 mW/g

SAR(1 g) = 0.235 mW/g; SAR(10 g) = 0.141 mW/g

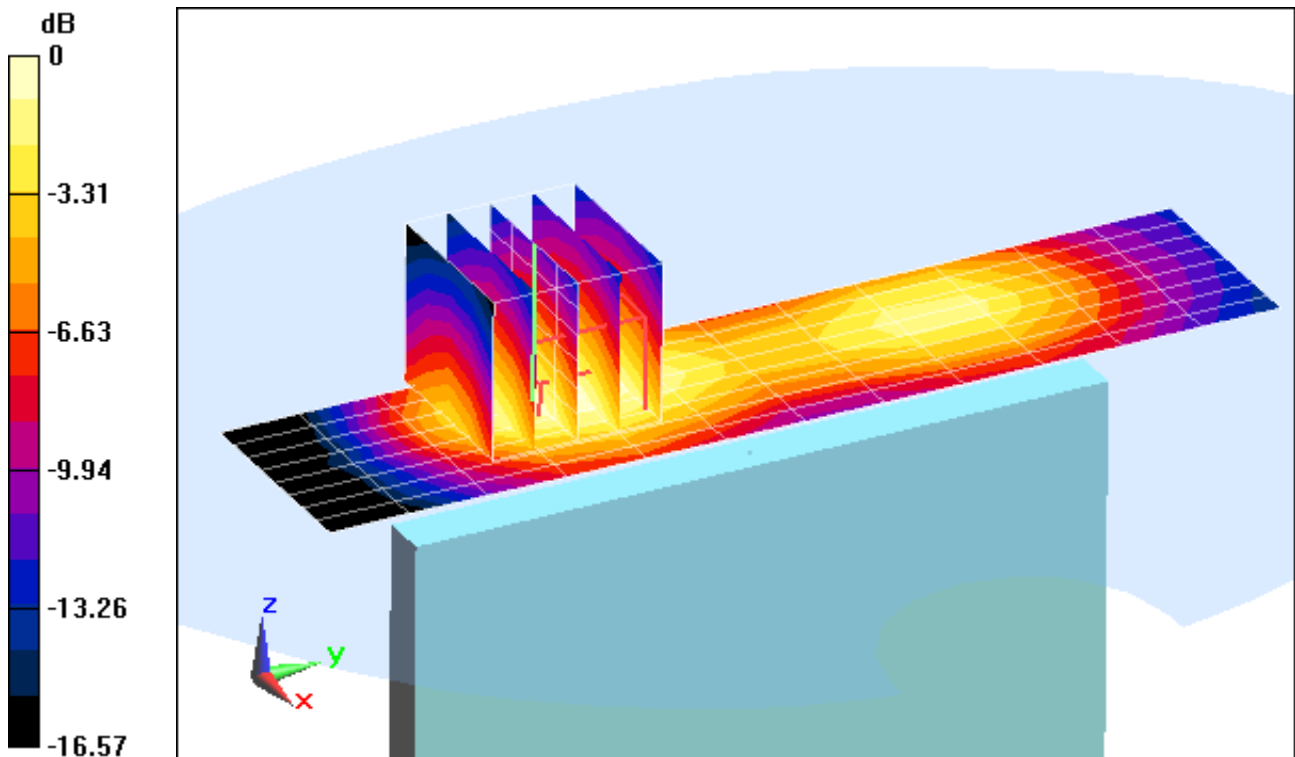

0 dB = 0.257 mW/g = -11.80 dB mW/g

PCTEST ENGINEERING LABORATORY, INC.

DUT: ZNFE970; Type: Portable Handset; Serial: LTE SAR#3

Communication System: LTE PCS 10 Mhz; Frequency: 1855 MHz; Duty Cycle: 1:1

Medium: 1900 Body Medium parameters used (interpolated):

$f = 1855 \text{ MHz}$; $\sigma = 1.466 \text{ mho/m}$; $\epsilon_r = 51.935$; $\rho = 1000 \text{ kg/m}^3$

Phantom section: Flat Section; Space: 1.0 cm

Test Date: 07-09-2012; Ambient Temp: 23.7°C; Tissue Temp: 24.8°C

Probe: ES3DV2 - SN3022; ConvF(4.41, 4.41, 4.41); Calibrated: 8/25/2011;

Sensor-Surface: 4mm (Mechanical Surface Detection)

Electronics: DAE4 Sn665; Calibrated: 4/19/2012

Phantom: SAM Sub Dasy B; Type: SAM 5.0; Serial: TP-1626

Measurement SW: DASY52, Version 52.8 (1); SEMCAD X Version 14.6.5 (6469)

Mode: LTE Band 2 (PCS), Body SAR, Back side, Low.ch
10 MHz Bandwidth, QPSK, 1 RB, 0 RB Offset

Area Scan (7x10x1): Measurement grid: dx=15mm, dy=15mm

Zoom Scan (5x5x7)/Cube 0: Measurement grid: dx=8mm, dy=8mm, dz=5mm

Reference Value = 21.982 V/m; Power Drift = -0.14 dB

Peak SAR (extrapolated) = 0.939 mW/g

SAR(1 g) = 0.623 mW/g; SAR(10 g) = 0.409 mW/g

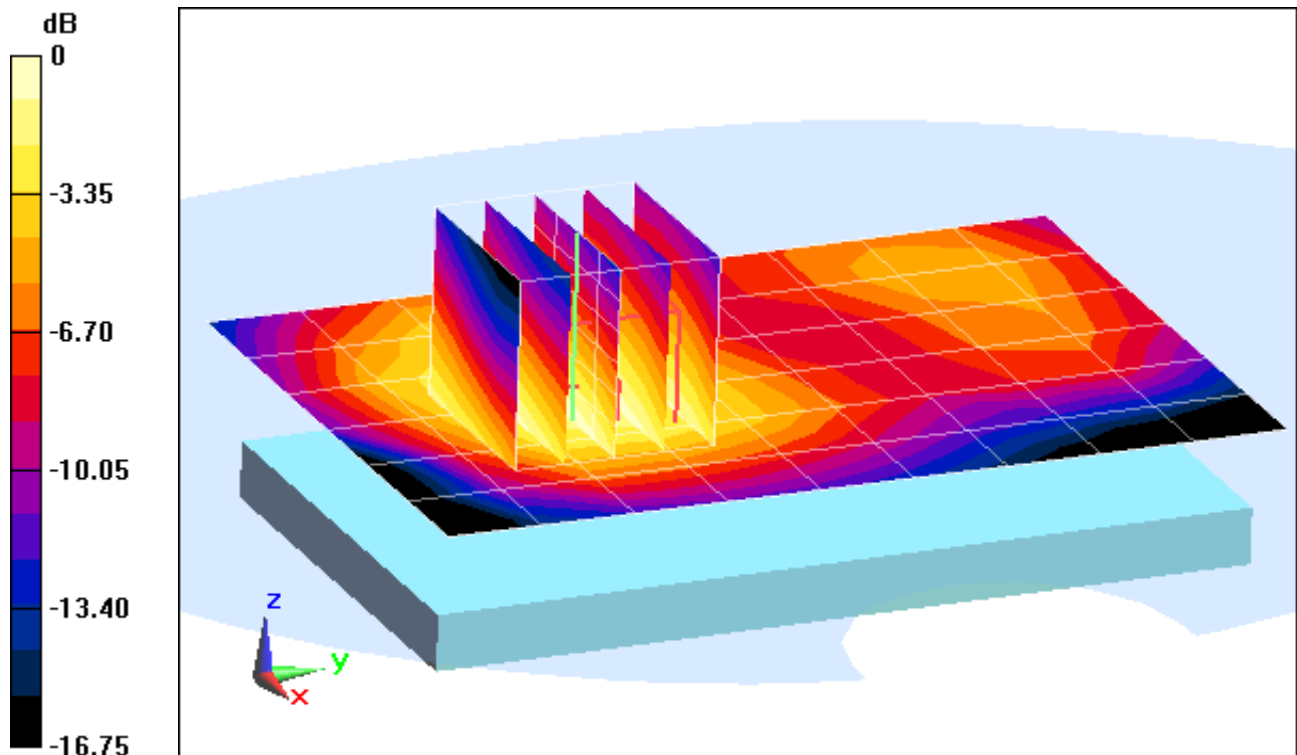

0 dB = 0.659 mW/g = -3.62 dB mW/g

PCTEST ENGINEERING LABORATORY, INC.

DUT: ZNFE970; Type: Portable Handset; Serial: LTE SAR#3

Communication System: LTE PCS 10 Mhz; Frequency: 1855 MHz; Duty Cycle: 1:1

Medium: 1900 Body Medium parameters used (interpolated):

$f = 1855 \text{ MHz}$; $\sigma = 1.466 \text{ mho/m}$; $\epsilon_r = 51.935$; $\rho = 1000 \text{ kg/m}^3$

Phantom section: Flat Section; Space: 1.0 cm

Test Date: 07-09-2012; Ambient Temp: 23.7°C; Tissue Temp: 24.8°C

Probe: ES3DV2 - SN3022; ConvF(4.41, 4.41, 4.41); Calibrated: 8/25/2011;

Sensor-Surface: 4mm (Mechanical Surface Detection)

Electronics: DAE4 Sn665; Calibrated: 4/19/2012

Phantom: SAM Sub Dasy B; Type: SAM 5.0; Serial: TP-1626

Measurement SW: DASY52, Version 52.8 (1); SEMCAD X Version 14.6.5 (6469)

Mode: LTE Band 2 (PCS), Body SAR, Front side, Low.ch
10 MHz Bandwidth, QPSK, 1 RB, 0 RB Offset

Area Scan (9x13x1): Measurement grid: dx=15mm, dy=15mm

Zoom Scan (5x5x7)/Cube 0: Measurement grid: dx=8mm, dy=8mm, dz=5mm

Reference Value = 19.261 V/m; Power Drift = 0.12 dB

Peak SAR (extrapolated) = 0.785 mW/g

SAR(1 g) = 0.494 mW/g; SAR(10 g) = 0.307 mW/g

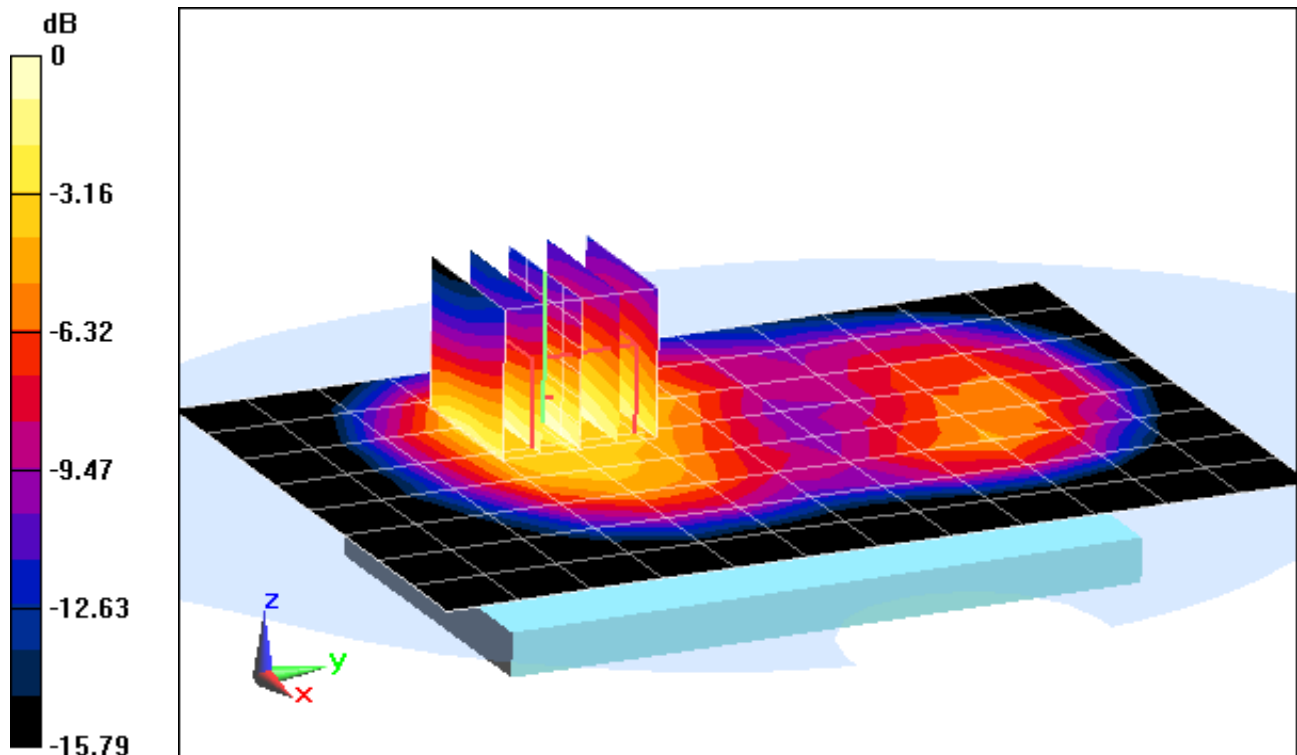

0 dB = 0.521 mW/g = -5.66 dB mW/g

PCTEST ENGINEERING LABORATORY, INC.

DUT: ZNFE970; Type: Portable Handset; Serial: LTE SAR#3

Communication System: LTE PCS 10 Mhz; Frequency: 1905 MHz; Duty Cycle: 1:1

Medium: 1900 Body Medium parameters used (interpolated):

$f = 1905 \text{ MHz}$; $\sigma = 1.515 \text{ mho/m}$; $\epsilon_r = 51.785$; $\rho = 1000 \text{ kg/m}^3$

Phantom section: Flat Section; Space: 1.0 cm

Test Date: 07-09-2012; Ambient Temp: 23.7°C; Tissue Temp: 24.8°C

Probe: ES3DV2 - SN3022; ConvF(4.41, 4.41, 4.41); Calibrated: 8/25/2011;

Sensor-Surface: 4mm (Mechanical Surface Detection)

Electronics: DAE4 Sn665; Calibrated: 4/19/2012

Phantom: SAM Sub Dasy B; Type: SAM 5.0; Serial: TP-1626

Measurement SW: DASY52, Version 52.8 (1); SEMCAD X Version 14.6.5 (6469)

Mode: LTE Band 2 (PCS), Body SAR, Bottom Edge, High.ch
10 MHz Bandwidth, 16QAM, 1 RB, 0 RB Offset

Area Scan (5x7x1): Measurement grid: dx=15mm, dy=15mm

Zoom Scan (5x5x7)/Cube 0: Measurement grid: dx=8mm, dy=8mm, dz=5mm

Reference Value = 15.263 V/m; Power Drift = -0.03 dB

Peak SAR (extrapolated) = 0.492 mW/g

SAR(1 g) = 0.303 mW/g; SAR(10 g) = 0.180 mW/g

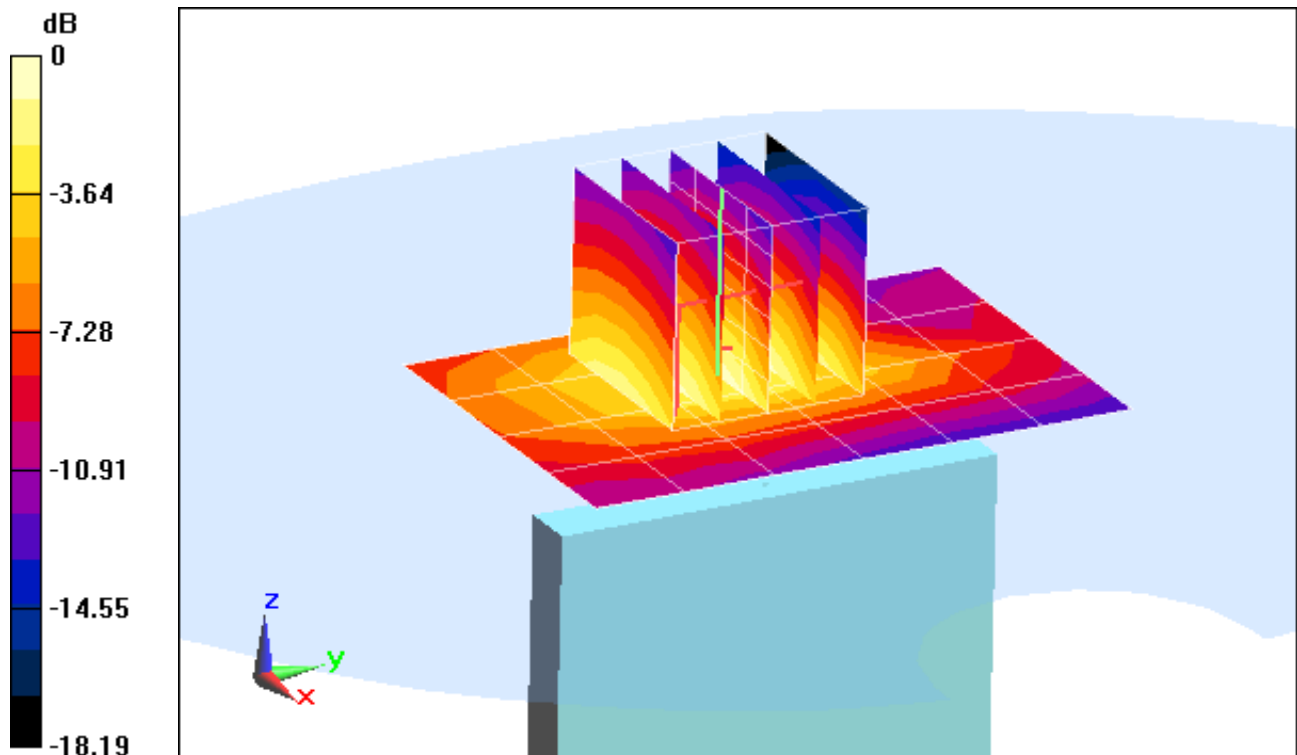

0 dB = 0.335 mW/g = -9.50 dB mW/g

PCTEST ENGINEERING LABORATORY, INC.

DUT: ZNFE970; Type: Portable Handset; Serial: LTE SAR#3

Communication System: LTE PCS 10 Mhz; Frequency: 1855 MHz; Duty Cycle: 1:1

Medium: 1900 Body Medium parameters used (interpolated):

$f = 1855 \text{ MHz}$; $\sigma = 1.466 \text{ mho/m}$; $\epsilon_r = 51.935$; $\rho = 1000 \text{ kg/m}^3$

Phantom section: Flat Section; Space: 1.0 cm

Test Date: 07-09-2012; Ambient Temp: 23.7°C; Tissue Temp: 24.8°C

Probe: ES3DV2 - SN3022; ConvF(4.41, 4.41, 4.41); Calibrated: 8/25/2011;

Sensor-Surface: 4mm (Mechanical Surface Detection)

Electronics: DAE4 Sn665; Calibrated: 4/19/2012

Phantom: SAM Sub Dasy B; Type: SAM 5.0; Serial: TP-1626

Measurement SW: DASY52, Version 52.8 (1); SEMCAD X Version 14.6.5 (6469)

Mode: LTE Band 2 (PCS), Body SAR, Left Edge, Low.ch
10 MHz Bandwidth, QPSK, 1 RB, 49 RB Offset

Area Scan (5x13x1): Measurement grid: dx=15mm, dy=15mm

Zoom Scan (5x5x7)/Cube 0: Measurement grid: dx=8mm, dy=8mm, dz=5mm

Reference Value = 19.318 V/m; Power Drift = 0.06 dB

Peak SAR (extrapolated) = 0.742 mW/g

SAR(1 g) = 0.486 mW/g; SAR(10 g) = 0.292 mW/g

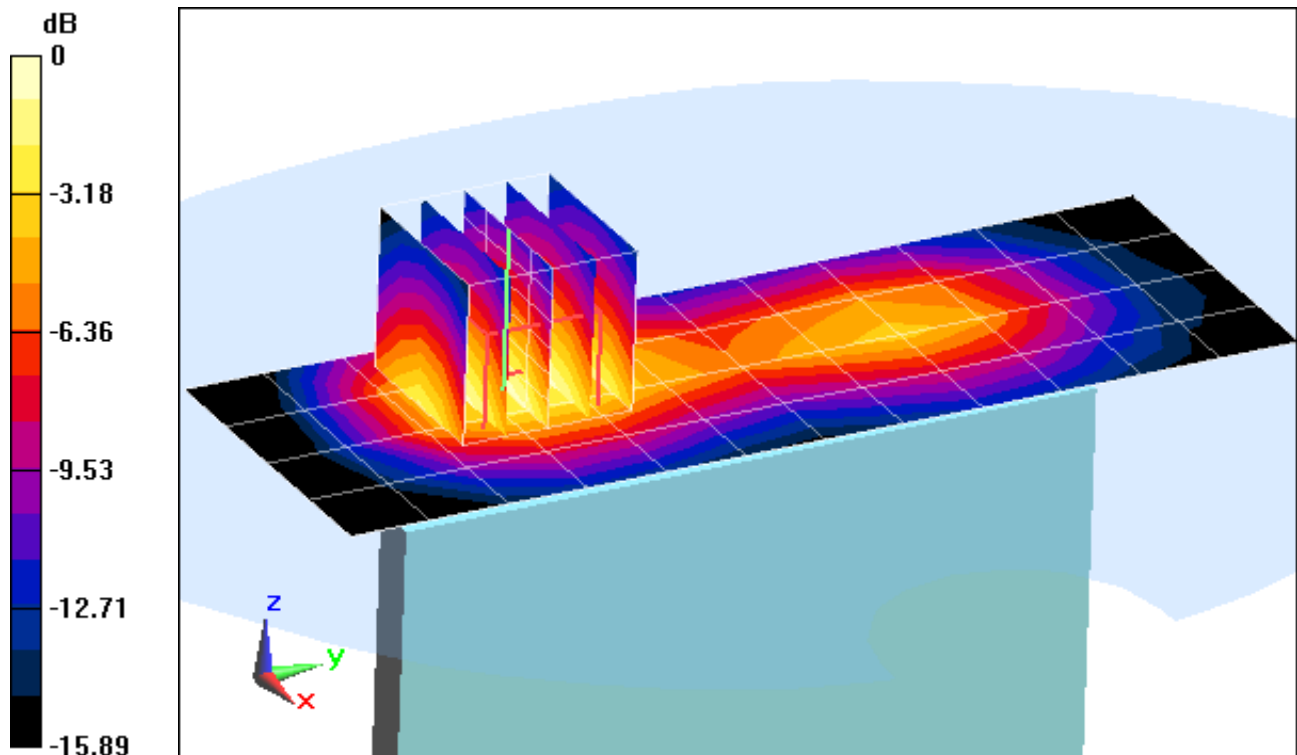

0 dB = 0.537 mW/g = -5.40 dB mW/g

PCTEST ENGINEERING LABORATORY, INC.

DUT: ZNFE970; Type: Portable Handset; Serial: WI-FI SAR #1

Communication System: IEEE 802.11b; Frequency: 2412 MHz; Duty Cycle: 1:1

Medium: 2450 Body Medium parameters used (interpolated):

$f = 2412 \text{ MHz}$; $\sigma = 1.846 \text{ mho/m}$; $\epsilon_r = 52.799$; $\rho = 1000 \text{ kg/m}^3$

Phantom section: Flat Section; Space: 1.0 cm

Test Date: 07-09-2012; Ambient Temp: 24.6°C; Tissue Temp: 24.0°C

Probe: ES3DV3 - SN3209; ConvF(4.23, 4.23, 4.23); Calibrated: 3/16/2012;

Sensor-Surface: 3mm (Mechanical Surface Detection)

Electronics: DAE4 Sn1323; Calibrated: 2/15/2012

Phantom: SAM Sub; Type: SAM 4.0; Serial: TP-1357

Measurement SW: DASY4, Version 4.7 (80); SEMCAD X Version 14.6.5 (6469)

Mode: IEEE 802.11b, Body SAR, Ch 01, 1 Mbps, Back Side

Area Scan (10x15x1): Measurement grid: dx=12mm, dy=12mm

Zoom Scan (7x7x7)/Cube 0: Measurement grid: dx=5mm, dy=5mm, dz=5mm

Reference Value = 16.516 V/m; Power Drift = -0.16 dB

Peak SAR (extrapolated) = 1.041 mW/g

SAR(1 g) = 0.494 mW/g; SAR(10 g) = 0.239 mW/g

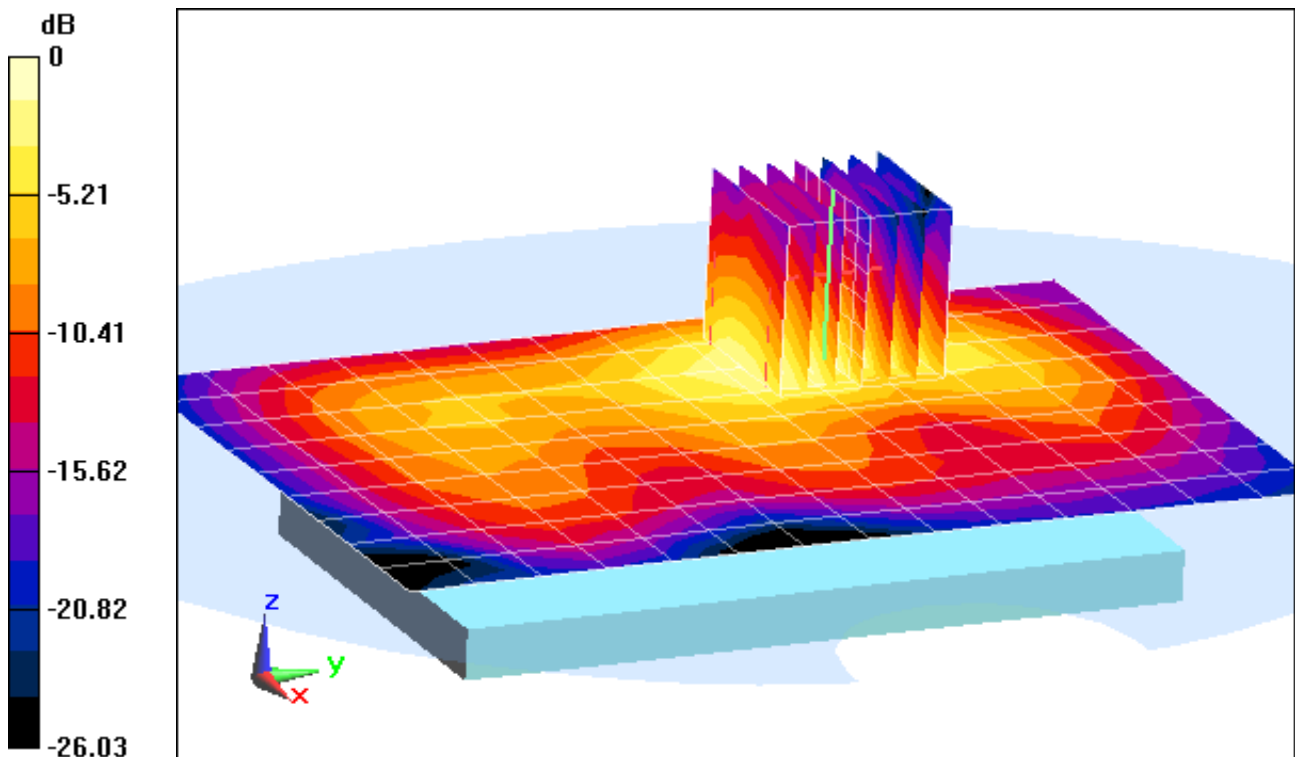

0 dB = 0.606 mW/g = -4.35 dB mW/g

PCTEST ENGINEERING LABORATORY, INC.

DUT: ZNFE970; Type: Portable Handset; Serial: WI-FI SAR #1

Communication System: IEEE 802.11b; Frequency: 2412 MHz; Duty Cycle: 1:1

Medium: 2450 Body Medium parameters used (interpolated):

$f = 2412 \text{ MHz}$; $\sigma = 1.846 \text{ mho/m}$; $\epsilon_r = 52.799$; $\rho = 1000 \text{ kg/m}^3$

Phantom section: Flat Section; Space: 1.0 cm

Test Date: 07-09-2012; Ambient Temp: 24.6°C; Tissue Temp: 24.0°C

Probe: ES3DV3 - SN3209; ConvF(4.23, 4.23, 4.23); Calibrated: 3/16/2012;

Sensor-Surface: 3mm (Mechanical Surface Detection)

Electronics: DAE4 Sn1323; Calibrated: 2/15/2012

Phantom: SAM Sub; Type: SAM 4.0; Serial: TP-1357

Measurement SW: DASY4, Version 4.7 (80); SEMCAD X Version 14.6.5 (6469)

Mode: IEEE 802.11b, Body SAR, Ch 01, 1 Mbps, Front Side

Area Scan (10x15x1): Measurement grid: dx=12mm, dy=12mm

Zoom Scan (7x7x7)/Cube 0: Measurement grid: dx=5mm, dy=5mm, dz=5mm

Reference Value = 5.820 V/m; Power Drift = 0.04 dB

Peak SAR (extrapolated) = 0.109 mW/g

SAR(1 g) = 0.058 mW/g; SAR(10 g) = 0.030 mW/g

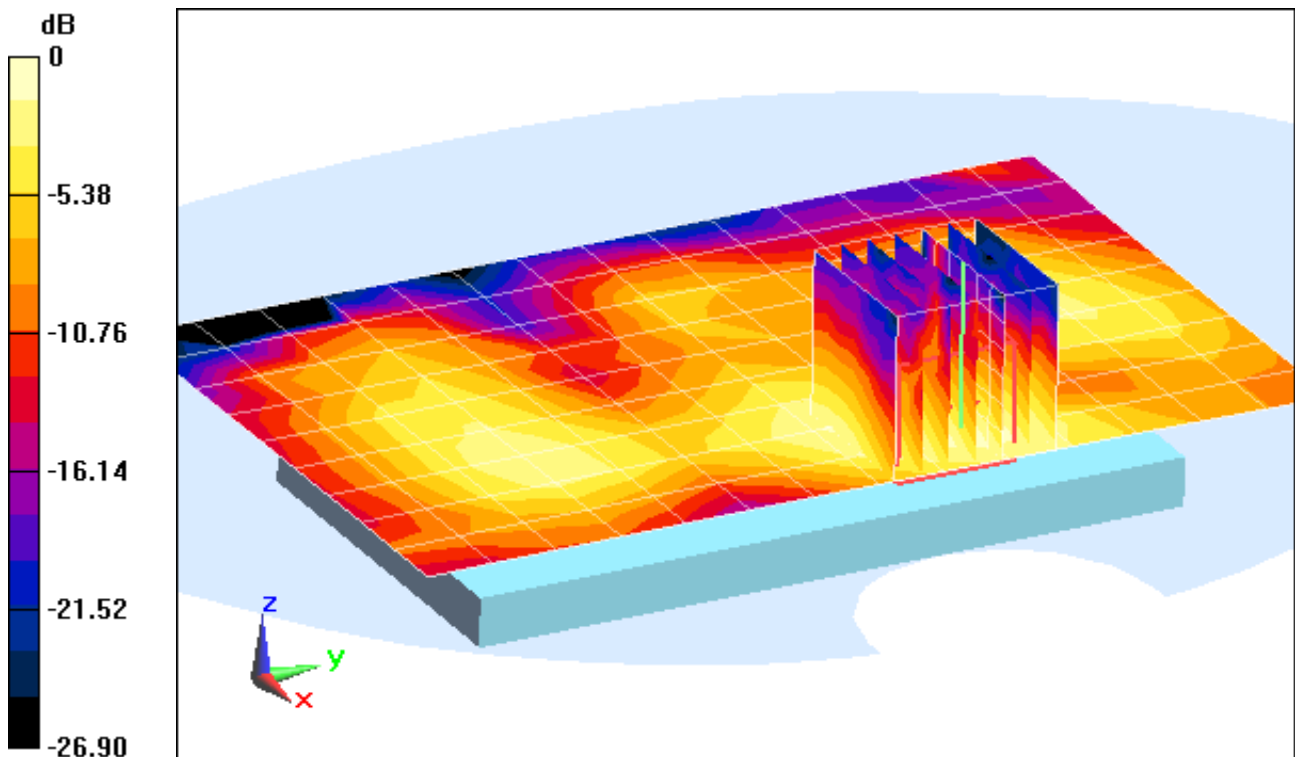

0 dB = 0.0740 mW/g = -22.62 dB mW/g

PCTEST ENGINEERING LABORATORY, INC.

DUT: ZNFE970; Type: Portable Handset; Serial: WI-FI SAR #1

Communication System: IEEE 802.11b; Frequency: 2412 MHz; Duty Cycle: 1:1

Medium: 2450 Body Medium parameters used (interpolated):

$f = 2412 \text{ MHz}$; $\sigma = 1.846 \text{ mho/m}$; $\epsilon_r = 52.799$; $\rho = 1000 \text{ kg/m}^3$

Phantom section: Flat Section; Space: 1.0 cm

Test Date: 07-09-2012; Ambient Temp: 24.6°C; Tissue Temp: 24.0°C

Probe: ES3DV3 - SN3209; ConvF(4.23, 4.23, 4.23); Calibrated: 3/16/2012;

Sensor-Surface: 3mm (Mechanical Surface Detection)

Electronics: DAE4 Sn1323; Calibrated: 2/15/2012

Phantom: SAM Sub; Type: SAM 4.0; Serial: TP-1357

Measurement SW: DASY4, Version 4.7 (80); SEMCAD X Version 14.6.5 (6469)

Mode: IEEE 802.11b, Body SAR, Ch 01, 1 Mbps, Top Edge

Area Scan (6x10x1): Measurement grid: dx=12mm, dy=12mm

Zoom Scan (7x7x7)/Cube 0: Measurement grid: dx=5mm, dy=5mm, dz=5mm

Reference Value = 5.487 V/m; Power Drift = 0.02 dB

Peak SAR (extrapolated) = 0.101 mW/g

SAR(1 g) = 0.052 mW/g; SAR(10 g) = 0.027 mW/g

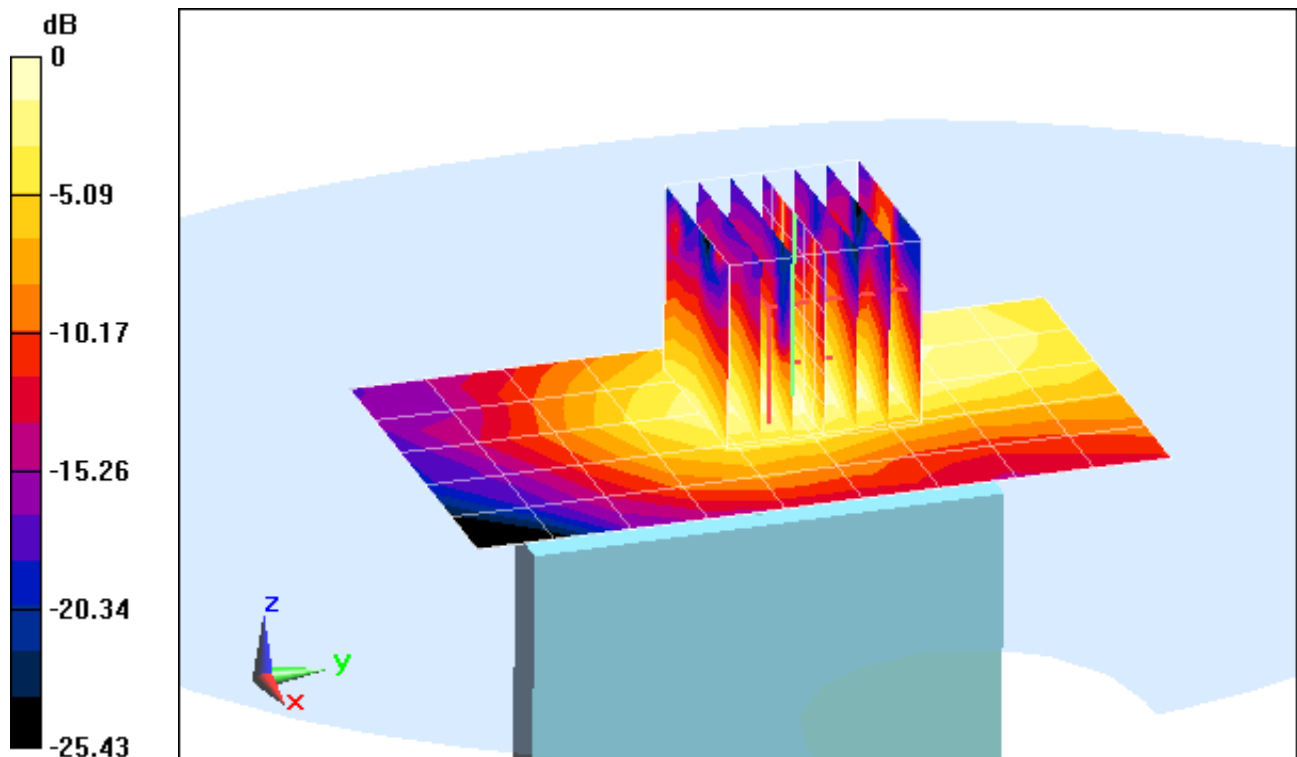

0 dB = 0.0650 mW/g = -23.74 dB mW/g

PCTEST ENGINEERING LABORATORY, INC.

DUT: ZNFE970; Type: Portable Handset; Serial: WI-FI SAR #1

Communication System: IEEE 802.11b; Frequency: 2412 MHz; Duty Cycle: 1:1

Medium: 2450 Body Medium parameters used (interpolated):

$f = 2412 \text{ MHz}$; $\sigma = 1.846 \text{ mho/m}$; $\epsilon_r = 52.799$; $\rho = 1000 \text{ kg/m}^3$

Phantom section: Flat Section; Space: 1.0 cm

Test Date: 07-09-2012; Ambient Temp: 24.6°C; Tissue Temp: 24.0°C

Probe: ES3DV3 - SN3209; ConvF(4.23, 4.23, 4.23); Calibrated: 3/16/2012;

Sensor-Surface: 3mm (Mechanical Surface Detection)

Electronics: DAE4 Sn1323; Calibrated: 2/15/2012

Phantom: SAM Sub; Type: SAM 4.0; Serial: TP-1357

Measurement SW: DASY4, Version 4.7 (80); SEMCAD X Version 14.6.5 (6469)

Mode: IEEE 802.11b, Body SAR, Ch 01, 1 Mbps, Right Edge

Area Scan (6x16x1): Measurement grid: dx=12mm, dy=12mm

Zoom Scan (7x7x7)/Cube 0: Measurement grid: dx=5mm, dy=5mm, dz=5mm

Reference Value = 10.845 V/m; Power Drift = -0.03 dB

Peak SAR (extrapolated) = 0.418 mW/g

SAR(1 g) = 0.203 mW/g; SAR(10 g) = 0.103 mW/g

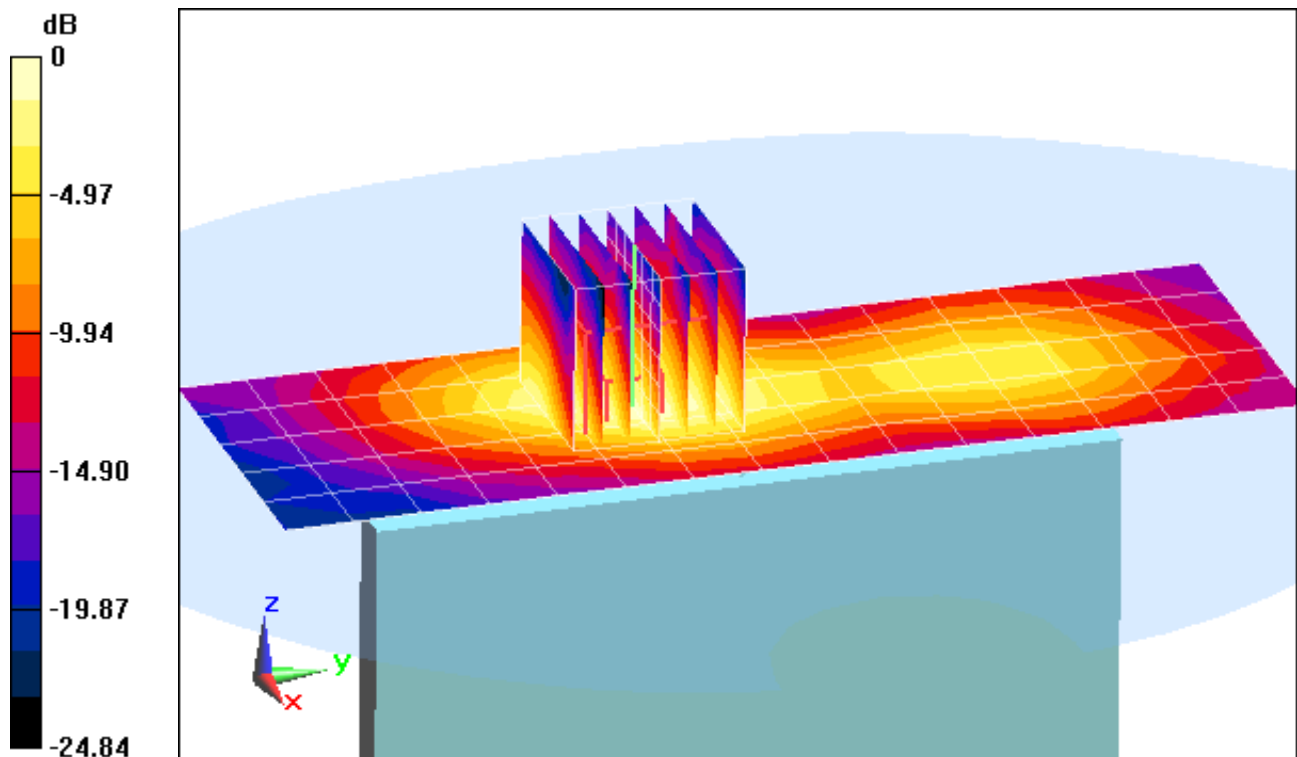

0 dB = 0.253 mW/g = -11.94 dB mW/g

PCTEST ENGINEERING LABORATORY, INC.

DUT: ZNFE970; Type: Portable Handset; Serial: WI-FI SAR #1

Communication System: IEEE 802.11a 5.2-5.8 GHz Band; Frequency: 5240 MHz; Duty Cycle: 1:1

Medium: 5 GHz Body Medium parameters used:

$f = 5240 \text{ MHz}$; $\sigma = 5.135 \text{ mho/m}$; $\epsilon_r = 49.93$; $\rho = 1000 \text{ kg/m}^3$

Phantom section: Flat Section; Space: 1.0 cm

Test Date: 07-05-2012; Ambient Temp: 24.7°C; Tissue Temp: 23.6°C

Probe: EX3DV4 - SN3589; ConvF(3.92, 3.92, 3.92); Calibrated: 1/27/2012;

Sensor-Surface: 2mm (Mechanical Surface Detection)

Electronics: DAE4 Sn1323; Calibrated: 2/15/2012

Phantom: SAM Main; Type: SAM 4.0; Serial: TP-1114

Measurement SW: DASY4, Version 4.7 (80); SEMCAD X Version 14.6.5 (6469)

Mode: IEEE 802.11a, 5.2 GHz, Body SAR, Ch 48, 6 Mbps, Back Side

Area Scan (13x19x1): Measurement grid: dx=10mm, dy=10mm

Zoom Scan (7x7x12)/Cube 0: Measurement grid: dx=4mm, dy=4mm, dz=2mm

Reference Value = 10.242 V/m; Power Drift = 0.04 dB

Peak SAR (extrapolated) = 1.560 mW/g

SAR(1 g) = 0.424 mW/g; SAR(10 g) = 0.101 mW/g

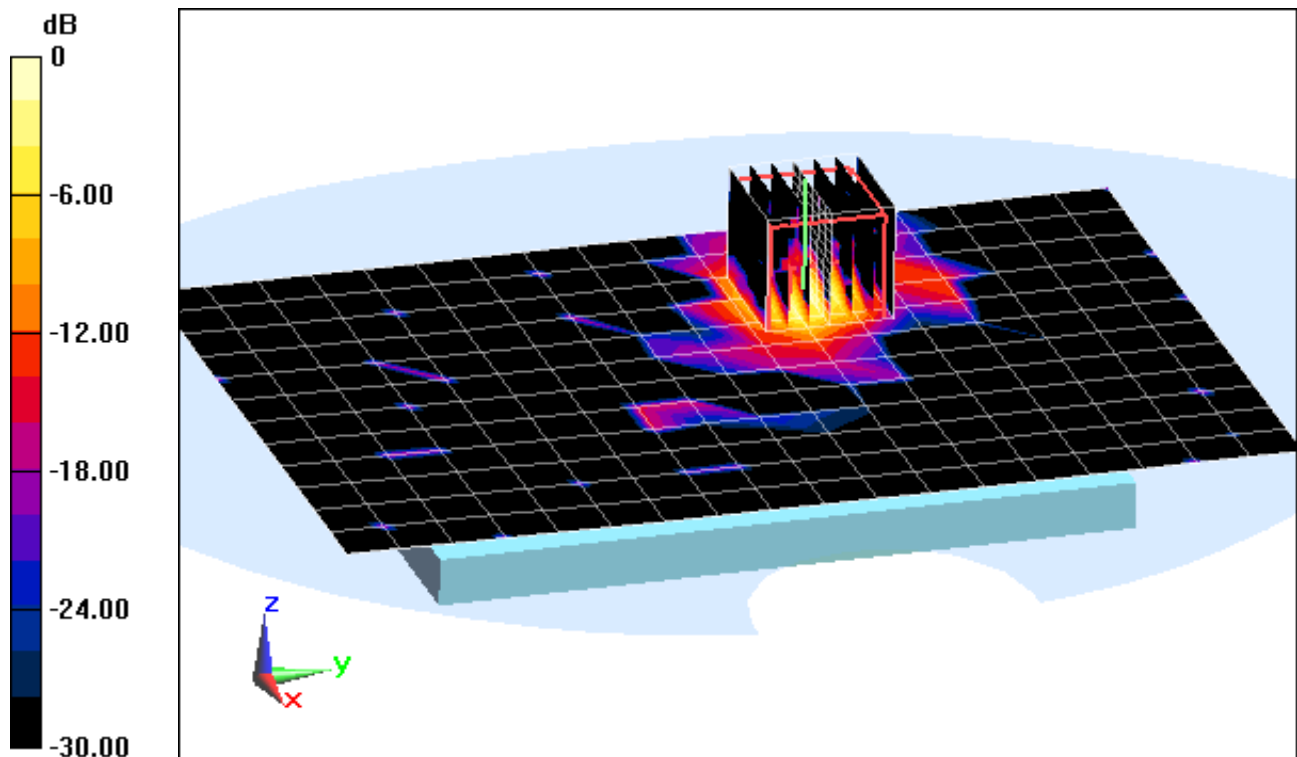

0 dB = 0.924 mW/g = -0.69 dB mW/g

APPENDIX B: SYSTEM VERIFICATION

PCTEST ENGINEERING LABORATORY, INC.

DUT: Dipole 750 MHz; Type: D750V3; Serial: 1054

Communication System: CW; Frequency: 750 MHz; Duty Cycle: 1:1

Medium: 740 Head; Medium parameters used (interpolated):

$f = 750$ MHz; $\sigma = 0.922$ mho/m; $\epsilon_r = 43.007$; $\rho = 1000$ kg/m³

Phantom section: Flat Section; Space: 1.5 cm

Test Date: 07-10-2012; Ambient Temp: 23.2°C; Tissue Temp: 22.5°C

Probe: ES3DV3 - SN3287; ConvF(6.25, 6.25, 6.25); Calibrated: 2/7/2012;

Sensor-Surface: 4mm (Mechanical Surface Detection)

Electronics: DAE4 Sn649; Calibrated: 2/20/2012

Phantom: SAM v5.0 Left; Type: QD000P40CD; Serial: TP: 1687

Measurement SW: DASY52, Version 52.8 (1);SEMCAD X Version 14.6.5 (6469)

750 MHz System Verification

Area Scan (7x15x1): Measurement grid: dx=15mm, dy=15mm

Zoom Scan (5x5x7)/Cube 0: Measurement grid: dx=8mm, dy=8mm, dz=5mm

Input Power = 20.0 dBm (100 mW)

Peak SAR (extrapolated) = 1.215 mW/g

SAR(1 g) = 0.833 mW/g; SAR(10 g) = 0.548 mW/g

Deviation = -2.23%

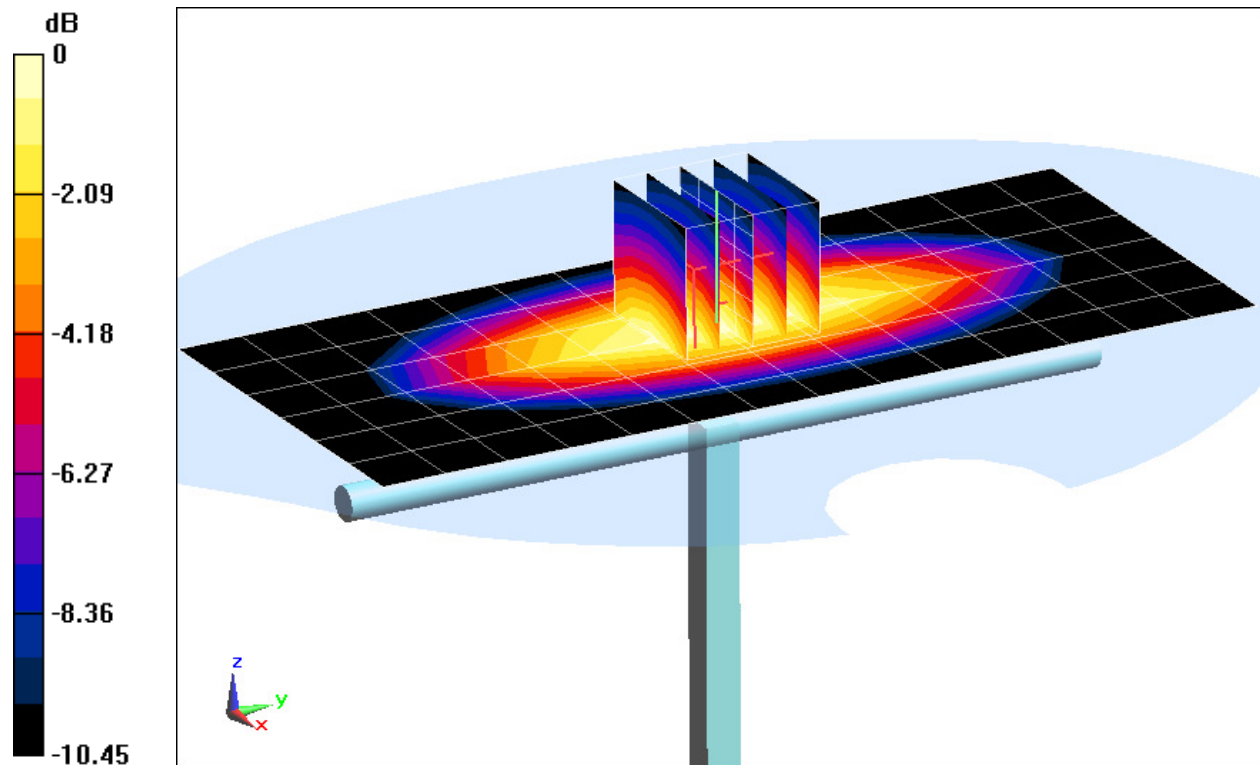

0 dB = 0.902 mW/g = -0.90 dB mW/g

PCTEST ENGINEERING LABORATORY, INC.

DUT: Dipole 750 MHz; Type: D750V3; Serial: 1054

Communication System: CW; Frequency: 750 MHz; Duty Cycle: 1:1

Medium: 740 Head; Medium parameters used (interpolated):

$f = 750 \text{ MHz}$; $\sigma = 0.922 \text{ mho/m}$; $\epsilon_r = 43.007$; $\rho = 1000 \text{ kg/m}^3$

Phantom section: Flat Section; Space: 1.5 cm

Test Date: 07-10-2012; Ambient Temp: 23.2°C; Tissue Temp: 22.5°C

Probe: ES3DV3 - SN3287; ConvF(6.25, 6.25, 6.25); Calibrated: 2/7/2012;

Sensor-Surface: 4mm (Mechanical Surface Detection)

Electronics: DAE4 Sn649; Calibrated: 2/20/2012

Phantom: SAM v5.0 Left; Type: QD000P40CD; Serial: TP: 1687

Measurement SW: DASY52, Version 52.8 (1);SEMCAD X Version 14.6.5 (6469)

750 MHz System Verification

Area Scan (7x15x1): Measurement grid: dx=15mm, dy=15mm

Zoom Scan (5x5x7)/Cube 0: Measurement grid: dx=8mm, dy=8mm, dz=5mm

Input Power = 20.0 dBm (100 mW)

Peak SAR (extrapolated) = 1.215 mW/g

SAR(1 g) = 0.833 mW/g; SAR(10 g) = 0.548 mW/g

Deviation = -2.23%

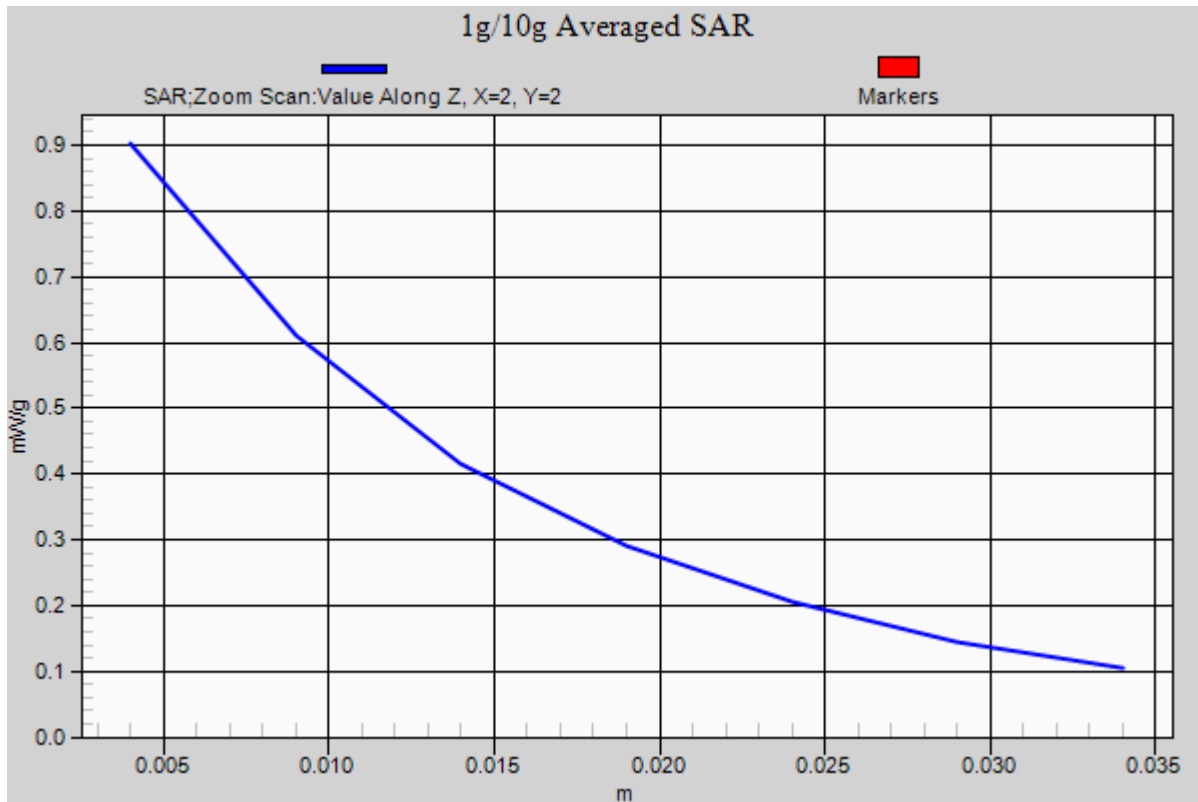

PCTEST ENGINEERING LABORATORY, INC.

DUT: Dipole 835 MHz; Type: D835V2; Serial: 4d133

Communication System: CW; Frequency: 835 MHz; Duty Cycle: 1:1

Medium: 835 Head Medium parameters used:

$f = 835 \text{ MHz}$; $\sigma = 0.906 \text{ mho/m}$; $\epsilon_r = 40.46$; $\rho = 1000 \text{ kg/m}^3$

Phantom section: Flat Section; Space: 1.5 cm

Test Date: 07-05-2012; Ambient Temp: 24.3°C; Tissue Temp: 23.4°C

Probe: ES3DV3 - SN3258; ConvF(6.01, 6.01, 6.01); Calibrated: 2/21/2012;

Sensor-Surface: 4mm (Mechanical Surface Detection)

Electronics: DAE4 Sn1272; Calibrated: 1/18/2012

Phantom: SAM Sub; Type: SAM 4.0; Serial: TP-1403

Measurement SW: DASY4, Version 4.7 (80); SEMCAD X Version 14.6.5 (6469)

835MHz System Verification

Area Scan (7x13x1): Measurement grid: dx=15mm, dy=15mm

Zoom Scan (5x5x7)/Cube 0: Measurement grid: dx=8mm, dy=8mm, dz=5mm

Input Power = 20 dBm (100 mW)

Peak SAR (extrapolated) = 1.500 mW/g

SAR(1 g) = 1.01 mW/g; SAR(10 g) = 0.661 mW/g

Deviation = 6.88%

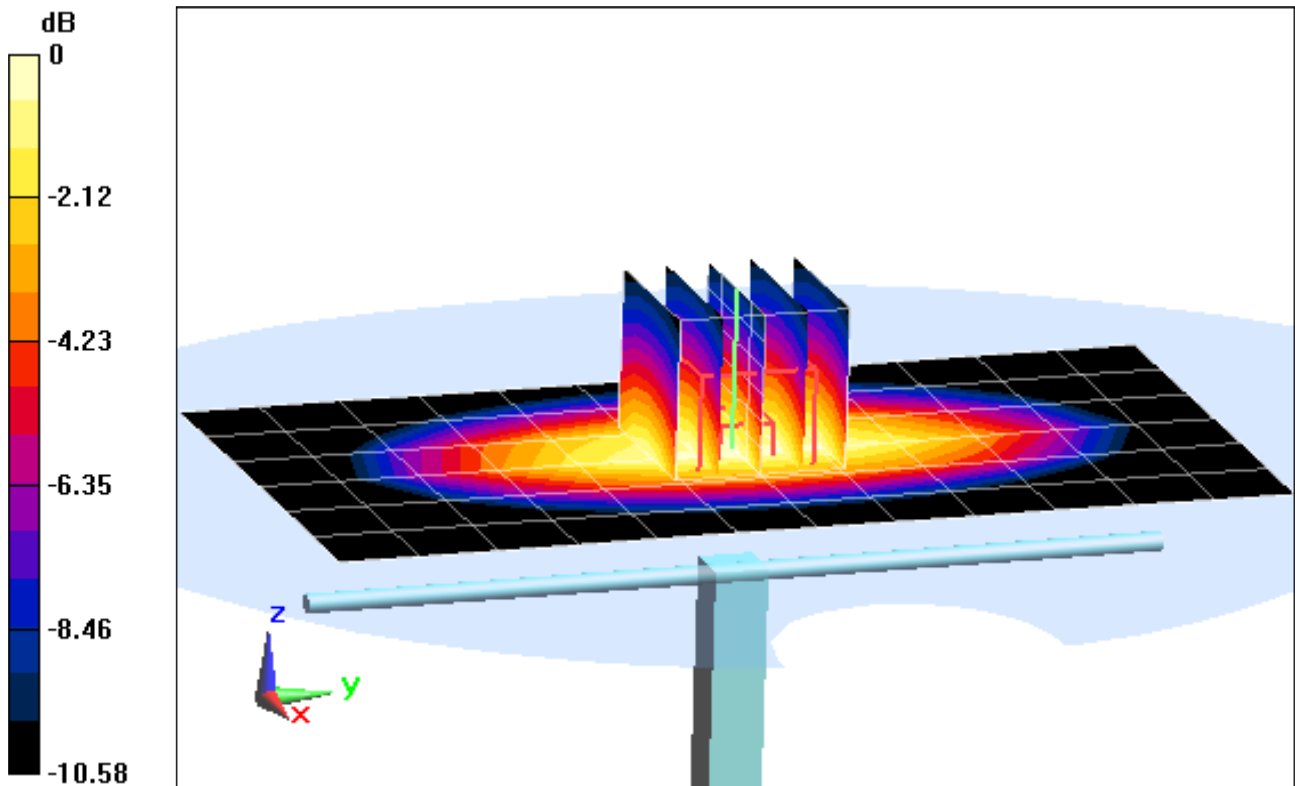

0 dB = 1.10 mW/g = 0.83 dB mW/g

PCTEST ENGINEERING LABORATORY, INC.

DUT: Dipole 835 MHz; Type: D835V2; Serial: 4d133

Communication System: CW; Frequency: 835 MHz; Duty Cycle: 1:1

Medium: 835 Head Medium parameters used:

$f = 835 \text{ MHz}$; $\sigma = 0.906 \text{ mho/m}$; $\epsilon_r = 40.46$; $\rho = 1000 \text{ kg/m}^3$

Phantom section: Flat Section; Space: 1.5 cm

Test Date: 07-05-2012; Ambient Temp: 24.3°C; Tissue Temp: 23.4°C

Probe: ES3DV3 - SN3258; ConvF(6.01, 6.01, 6.01); Calibrated: 2/21/2012;

Sensor-Surface: 4mm (Mechanical Surface Detection)

Electronics: DAE4 Sn1272; Calibrated: 1/18/2012

Phantom: SAM Sub; Type: SAM 4.0; Serial: TP-1403

Measurement SW: DASY4, Version 4.7 (80); SEMCAD X Version 14.6.5 (6469)

835MHz System Verification

Area Scan (7x13x1): Measurement grid: dx=15mm, dy=15mm

Zoom Scan (5x5x7)/Cube 0: Measurement grid: dx=8mm, dy=8mm, dz=5mm

Input Power = 20 dBm (100 mW)

Peak SAR (extrapolated) = 1.500 mW/g

SAR(1 g) = 1.01 mW/g; SAR(10 g) = 0.661 mW/g

Deviation = 6.88%

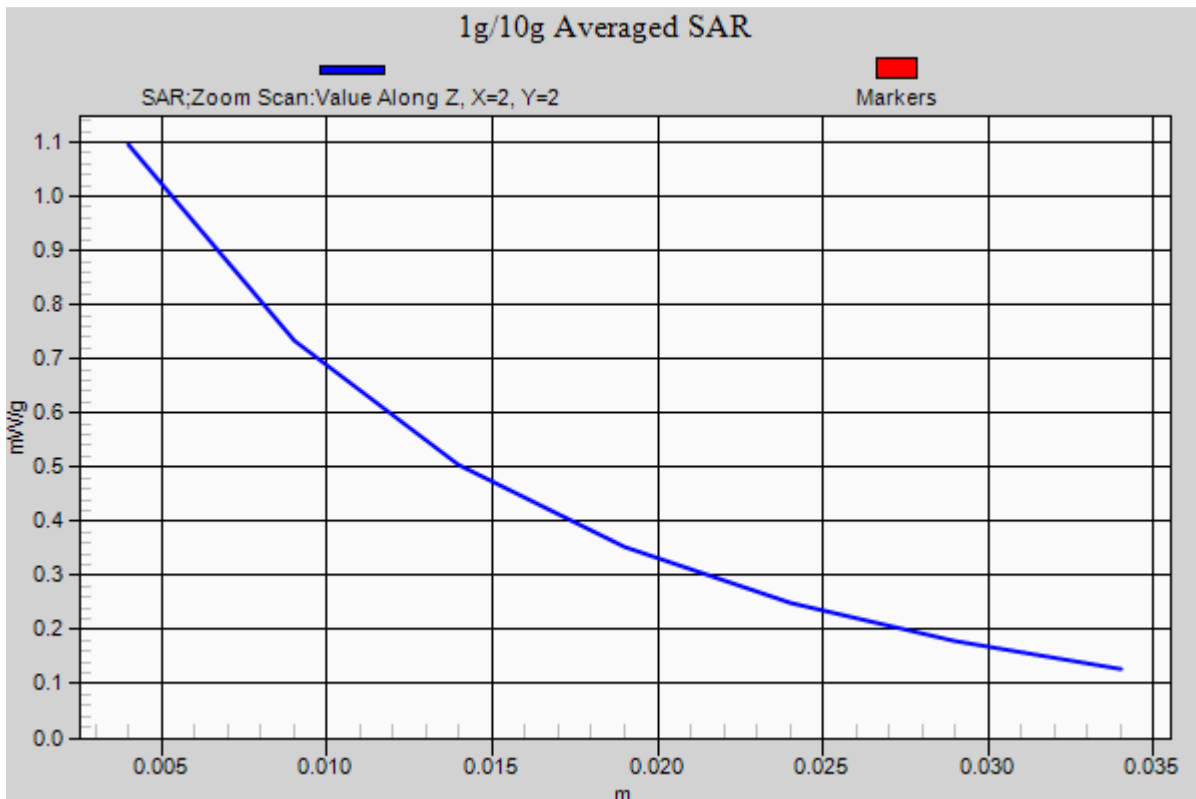

PCTEST ENGINEERING LABORATORY, INC.

DUT: Dipole 835 MHz; Type: D835V2; Serial: 4d119

Communication System: CW; Frequency: 835 MHz; Duty Cycle: 1:1

Medium: 835 Head Medium parameters used:

$f = 835 \text{ MHz}$; $\sigma = 0.892 \text{ mho/m}$; $\epsilon_r = 39.6$; $\rho = 1000 \text{ kg/m}^3$

Phantom section: Flat Section; Space: 1.5 cm

Test Date: 08-22-2012; Ambient Temp: 24.9°C; Tissue Temp: 24.6°C

Probe: ES3DV3 - SN3258; ConvF(6.01, 6.01, 6.01); Calibrated: 2/21/2012;

Sensor-Surface: 4mm (Mechanical Surface Detection)

Electronics: DAE4 Sn1272; Calibrated: 1/18/2012

Phantom: SAM Sub; Type: SAM 4.0; Serial: TP-1403

Measurement SW: DASY4, Version 4.7 (80); SEMCAD X Version 14.6.5 (6469)

835MHz System Verification

Area Scan (7x13x1): Measurement grid: dx=15mm, dy=15mm

Zoom Scan (5x5x7)/Cube 0: Measurement grid: dx=8mm, dy=8mm, dz=5mm

Input Power = 20 dBm (100 mW)

Peak SAR (extrapolated) = 1.418 mW/g

SAR(1 g) = 0.962 mW/g; SAR(10 g) = 0.631 mW/g

Deviation = 2.12%

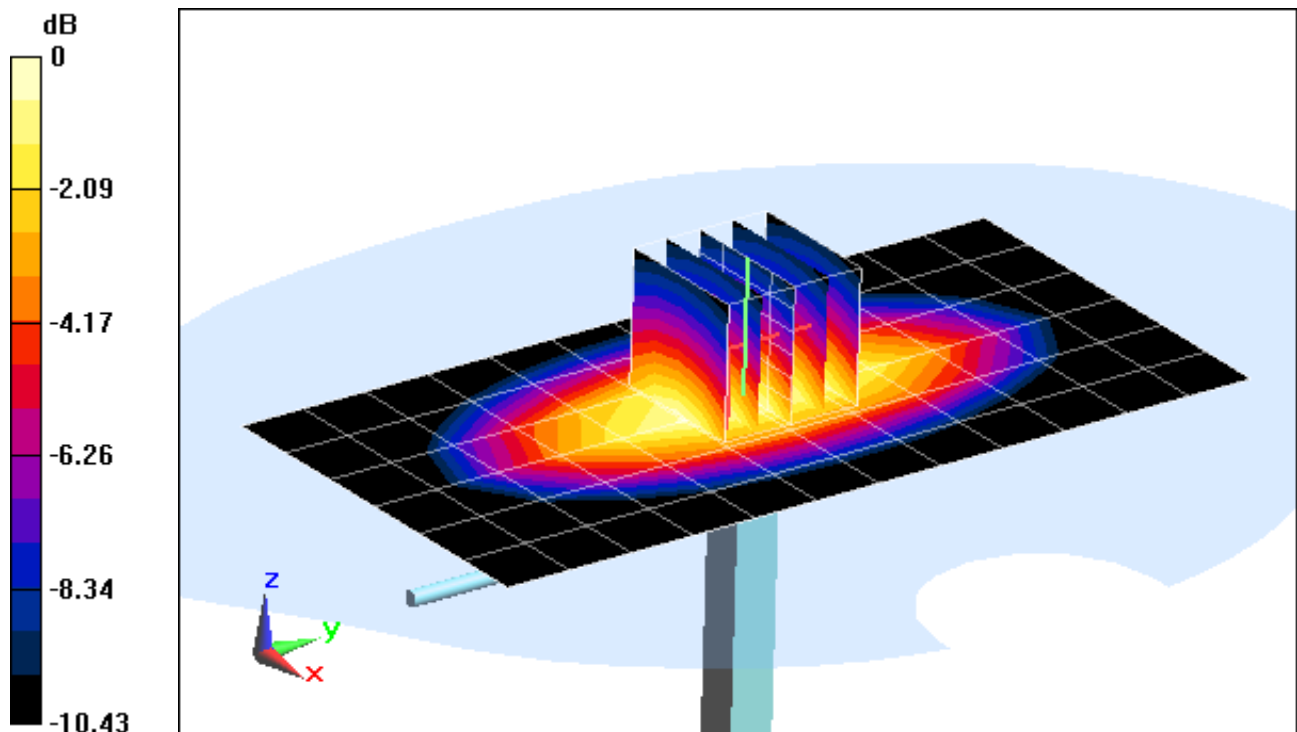

0 dB = 1.04 mW/g = 0.34 dB mW/g

PCTEST ENGINEERING LABORATORY, INC.

DUT: Dipole 835 MHz; Type: D835V2; Serial: 4d119

Communication System: CW; Frequency: 835 MHz; Duty Cycle: 1:1

Medium: 835 Head Medium parameters used:

$f = 835 \text{ MHz}$; $\sigma = 0.892 \text{ mho/m}$; $\epsilon_r = 39.6$; $\rho = 1000 \text{ kg/m}^3$

Phantom section: Flat Section; Space: 1.5 cm

Test Date: 08-22-2012; Ambient Temp: 24.9°C; Tissue Temp: 24.6°C

Probe: ES3DV3 - SN3258; ConvF(6.01, 6.01, 6.01); Calibrated: 2/21/2012;

Sensor-Surface: 4mm (Mechanical Surface Detection)

Electronics: DAE4 Sn1272; Calibrated: 1/18/2012

Phantom: SAM Sub; Type: SAM 4.0; Serial: TP-1403

Measurement SW: DASY4, Version 4.7 (80); SEMCAD X Version 14.6.5 (6469)

835MHz System Verification

Area Scan (7x13x1): Measurement grid: dx=15mm, dy=15mm

Zoom Scan (5x5x7)/Cube 0: Measurement grid: dx=8mm, dy=8mm, dz=5mm

Input Power = 20 dBm (100 mW)

Peak SAR (extrapolated) = 1.418 mW/g

SAR(1 g) = 0.962 mW/g; SAR(10 g) = 0.631 mW/g

Deviation = 2.12%

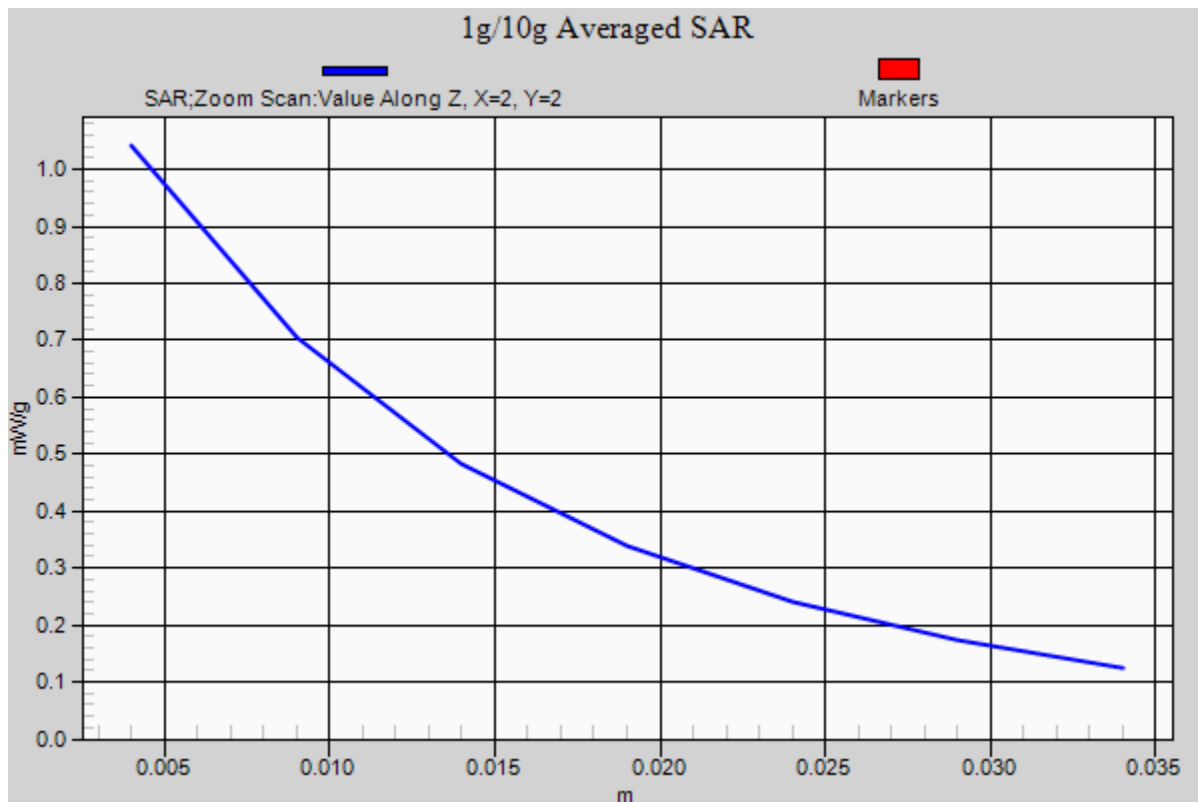

PCTEST ENGINEERING LABORATORY, INC.

DUT: Dipole 1750 MHz; Type: D1765V2; Serial: 1008

Communication System: CW; Frequency: 1750 MHz; Duty Cycle: 1:1
Medium: 1750 Head Medium parameters used:

$f = 1750 \text{ MHz}$; $\sigma = 1.391 \text{ mho/m}$; $\epsilon_r = 38.88$; $\rho = 1000 \text{ kg/m}^3$

Phantom section: Flat Section; Space: 1.0 cm

Test Date: 07-06-2012; Ambient Temp: 23.9°C; Tissue Temp: 23.1°C

Probe: ES3DV2 - SN3022; ConvF(5.2, 5.2, 5.2); Calibrated: 8/25/2011;
Sensor-Surface: 4mm (Mechanical Surface Detection)

Electronics: DAE4 Sn665; Calibrated: 4/19/2012

Phantom: SAM with CRP; Type: SAM; Serial: TP1375

Measurement SW: DASY4, Version 4.7 (80); SEMCAD X Version 14.6.5 (6469)

1750 MHz System Verification

Area Scan (6x6x1): Measurement grid: dx=15mm, dy=15mm

Zoom Scan (5x5x7)/Cube 0: Measurement grid: dx=8mm, dy=8mm, dz=5mm

Input Power = 20 dBm (100 mW)

Peak SAR (extrapolated) = 6.722 mW/g

SAR(1 g) = 3.77 mW/g; SAR(10 g) = 2.01 mW/g

Deviation = 3.57%

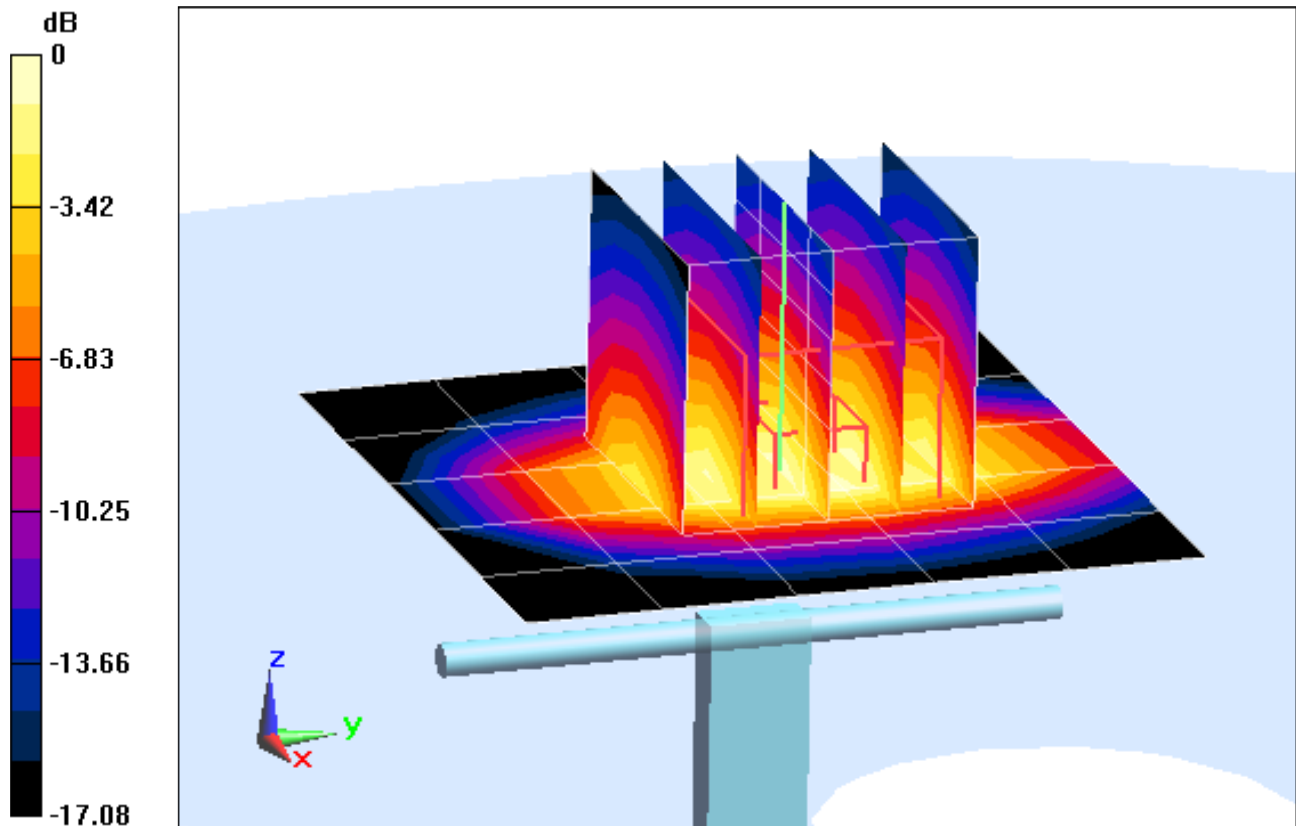

0 dB = 4.20 mW/g = 12.46 dB mW/g

PCTEST ENGINEERING LABORATORY, INC.

DUT: Dipole 1750 MHz; Type: D1765V2; Serial: 1008

Communication System: CW; Frequency: 1750 MHz; Duty Cycle: 1:1
Medium: 1750 Head Medium parameters used:

$f = 1750 \text{ MHz}$; $\sigma = 1.391 \text{ mho/m}$; $\epsilon_r = 38.88$; $\rho = 1000 \text{ kg/m}^3$

Phantom section: Flat Section; Space: 1.0 cm

Test Date: 07-06-2012; Ambient Temp: 23.9°C; Tissue Temp: 23.1°C

Probe: ES3DV2 - SN3022; ConvF(5.2, 5.2, 5.2); Calibrated: 8/25/2011;
Sensor-Surface: 4mm (Mechanical Surface Detection)

Electronics: DAE4 Sn665; Calibrated: 4/19/2012

Phantom: SAM with CRP; Type: SAM; Serial: TP1375

Measurement SW: DASY4, Version 4.7 (80); SEMCAD X Version 14.6.5 (6469)

1750 MHz System Verification

Area Scan (6x6x1): Measurement grid: dx=15mm, dy=15mm

Zoom Scan (5x5x7)/Cube 0: Measurement grid: dx=8mm, dy=8mm, dz=5mm

Input Power = 20 dBm (100 mW)

Peak SAR (extrapolated) = 6.722 mW/g

SAR(1 g) = 3.77 mW/g; SAR(10 g) = 2.01 mW/g

Deviation = 3.57%

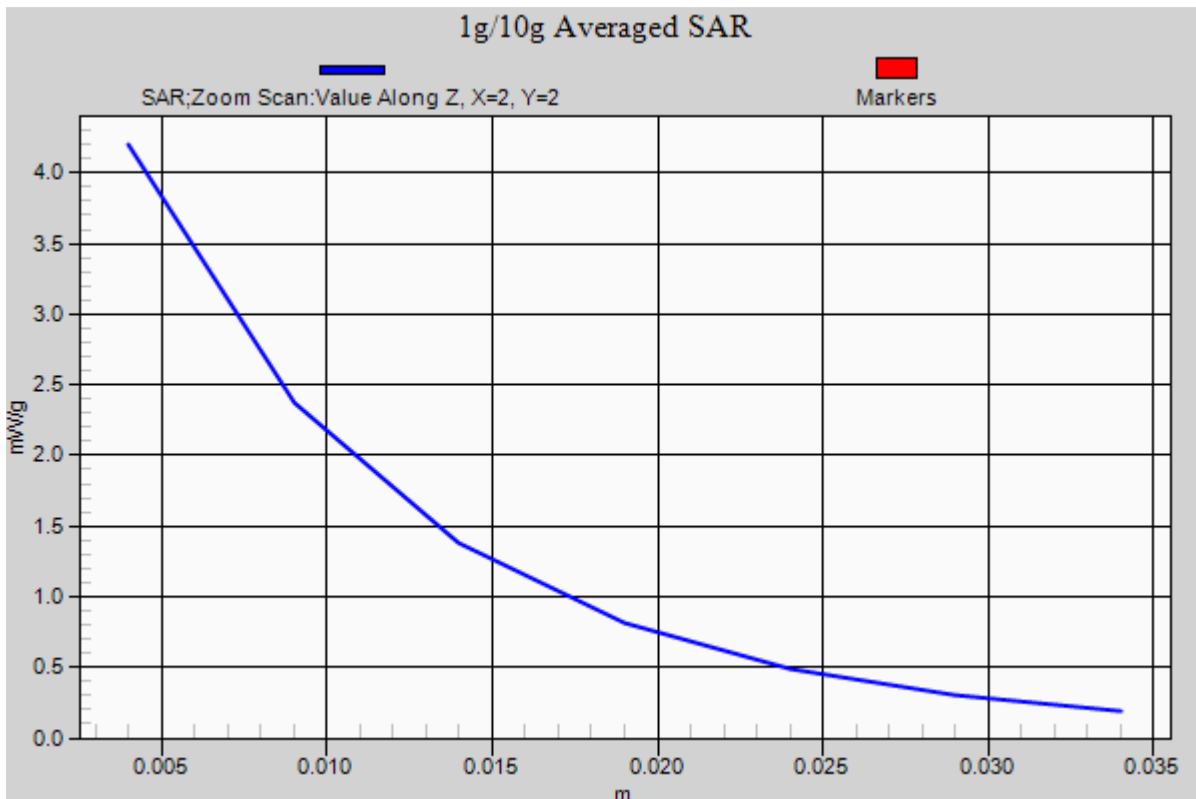

PCTEST ENGINEERING LABORATORY, INC.

DUT: SAR Dipole 1900 MHz; Type: D1900V2; Serial: 5d141

Communication System: CW; Frequency: 1900 MHz; Duty Cycle: 1:1

Medium: 1900 Head Medium parameters used (interpolated):

$f = 1900 \text{ MHz}$; $\sigma = 1.447 \text{ mho/m}$; $\epsilon_r = 38.173$; $\rho = 1000 \text{ kg/m}^3$

Phantom section: Flat Section; Space: 1.0 cm

Test Date: 07-11-2012; Ambient Temp: 24.6°C; Tissue Temp: 23.8°C

Probe: ES3DV3 - SN3209; ConvF(5.15, 5.15, 5.15); Calibrated: 3/16/2012;

Sensor-Surface: 4mm (Mechanical Surface Detection)

Electronics: DAE4 Sn1323; Calibrated: 2/15/2012

Phantom: SAM Main; Type: SAM 4.0; Serial: TP-1114

Measurement SW: DASY4, Version 4.7 (80); SEMCAD X Version 14.6.5 (6469)

1900MHz System Verification

Area Scan (5x7x1): Measurement grid: dx=15mm, dy=15mm

Zoom Scan (5x5x7)/Cube 0: Measurement grid: dx=8mm, dy=8mm, dz=5mm

Input Power = 20 dBm (100 mW)

Peak SAR (extrapolated) = 7.737 mW/g

SAR(1 g) = 4.13 mW/g; SAR(10 g) = 2.14 mW/g

Deviation = 3.77%

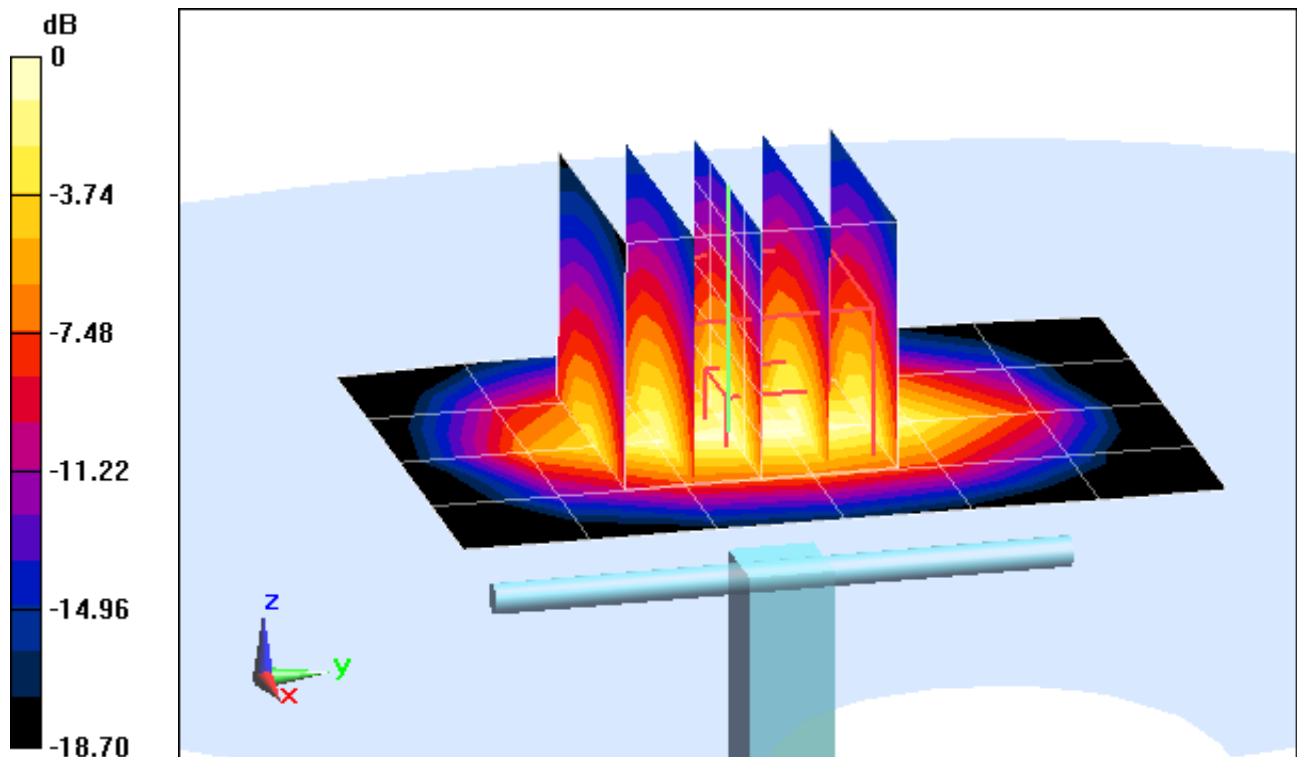

0 dB = 4.56 mW/g = 13.18 dB mW/g

PCTEST ENGINEERING LABORATORY, INC.

DUT: SAR Dipole 1900 MHz; Type: D1900V2; Serial: 5d141

Communication System: CW; Frequency: 1900 MHz; Duty Cycle: 1:1

Medium: 1900 Head Medium parameters used (interpolated):

$f = 1900 \text{ MHz}$; $\sigma = 1.447 \text{ mho/m}$; $\epsilon_r = 38.173$; $\rho = 1000 \text{ kg/m}^3$

Phantom section: Flat Section; Space: 1.0 cm

Test Date: 07-11-2012; Ambient Temp: 24.6°C; Tissue Temp: 23.8°C

Probe: ES3DV3 - SN3209; ConvF(5.15, 5.15, 5.15); Calibrated: 3/16/2012;

Sensor-Surface: 4mm (Mechanical Surface Detection)

Electronics: DAE4 Sn1323; Calibrated: 2/15/2012

Phantom: SAM Main; Type: SAM 4.0; Serial: TP-1114

Measurement SW: DASY4, Version 4.7 (80); SEMCAD X Version 14.6.5 (6469)

1900MHz System Verification

Area Scan (5x7x1): Measurement grid: dx=15mm, dy=15mm

Zoom Scan (5x5x7)/Cube 0: Measurement grid: dx=8mm, dy=8mm, dz=5mm

Input Power = 20 dBm (100 mW)

Peak SAR (extrapolated) = 7.737 mW/g

SAR(1 g) = 4.13 mW/g; SAR(10 g) = 2.14 mW/g

Deviation = 3.77%

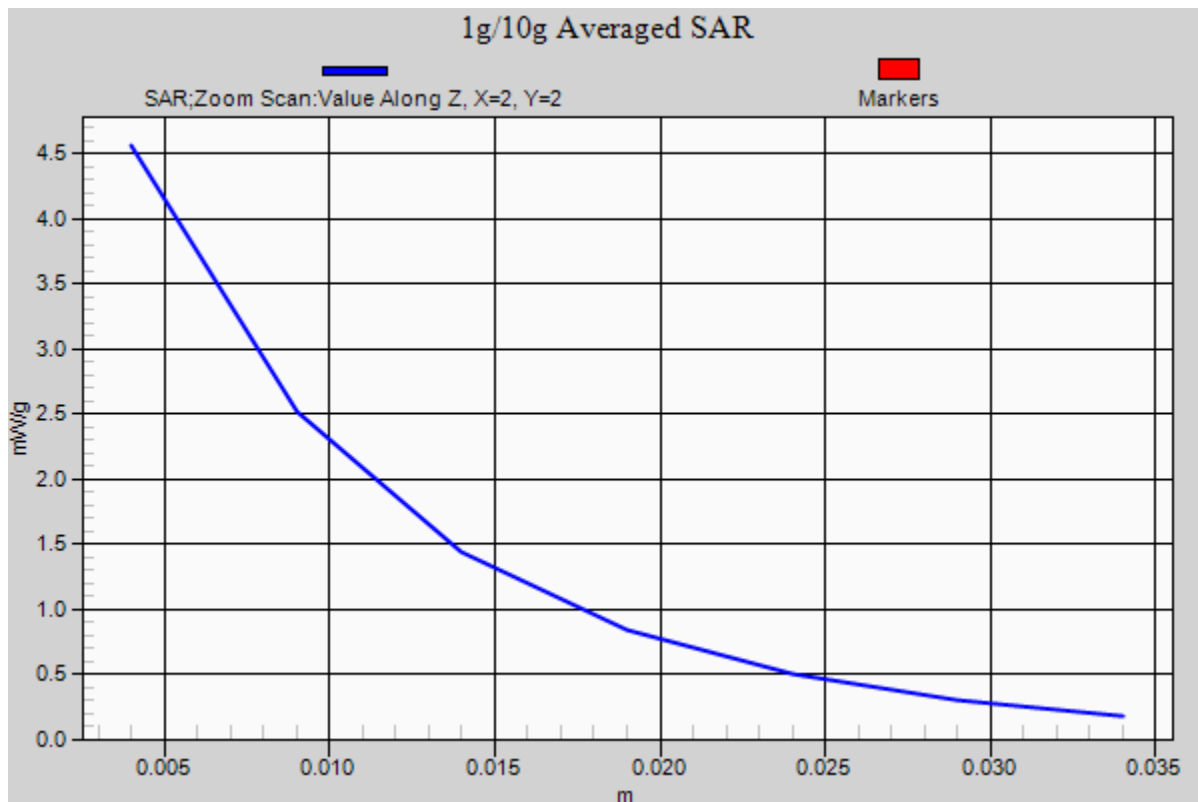

PCTEST ENGINEERING LABORATORY, INC.

DUT: SAR Dipole 1900 MHz; Type: D1900V2; Serial: 5d149

Communication System: CW; Frequency: 1900 MHz; Duty Cycle: 1:1

Medium: 1900 Head Medium parameters used (interpolated):

$f = 1900 \text{ MHz}$; $\sigma = 1.443 \text{ mho/m}$; $\epsilon_r = 40.933$; $\rho = 1000 \text{ kg/m}^3$

Phantom section: Flat Section; Space: 1.0 cm

Test Date: 08-23-2012; Ambient Temp: 23.9°C; Tissue Temp: 22.7°C

Probe: ES3DV3 - SN3287; ConvF(5.06, 5.06, 5.06); Calibrated: 2/7/2012;

Sensor-Surface: 4mm (Mechanical Surface Detection)

Electronics: DAE4 Sn649; Calibrated: 2/20/2012

Phantom: SAM v5.0 front; Type: QD000P40CD; Serial: TP-1646

Measurement SW: DASY52, Version 52.8 (1); SEMCAD X Version 14.6.5 (6469)

1900 MHz System Verification

Area Scan (7x9x1): Measurement grid: dx=15mm, dy=15mm

Zoom Scan (5x5x7)/Cube 0: Measurement grid: dx=8mm, dy=8mm, dz=5mm

Input Power: 20.0 dBm (100 mW)

Peak SAR (extrapolated) = 7.789 mW/g

SAR(1 g) = 4.18 mW/g; SAR(10 g) = 2.17 mW/g

Deviation: 6.36%

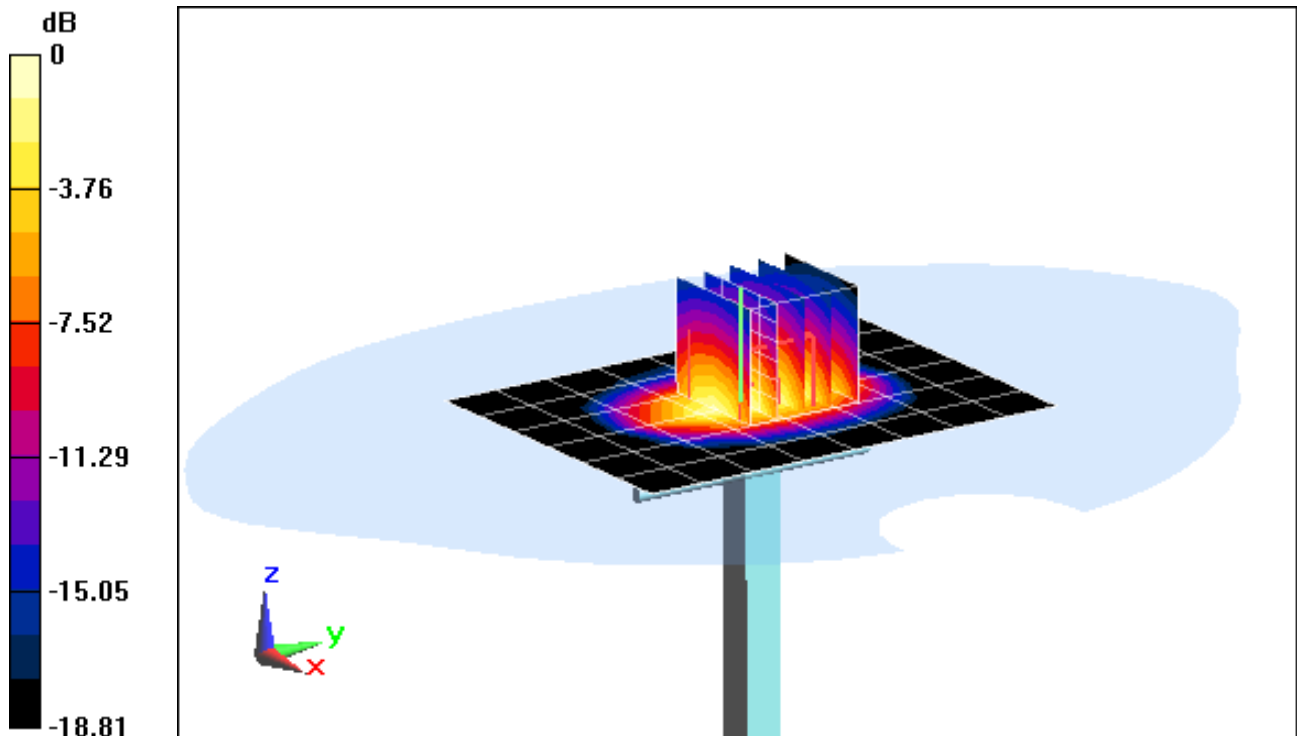

0 dB = 4.64 mW/g = 13.33 dB mW/g

PCTEST ENGINEERING LABORATORY, INC.

DUT: SAR Dipole 1900 MHz; Type: D1900V2; Serial: 5d149

Communication System: CW; Frequency: 1900 MHz; Duty Cycle: 1:1

Medium: 1900 Head Medium parameters used (interpolated):

$f = 1900 \text{ MHz}$; $\sigma = 1.443 \text{ mho/m}$; $\epsilon_r = 40.933$; $\rho = 1000 \text{ kg/m}^3$

Phantom section: Flat Section; Space: 1.0 cm

Test Date: 08-23-2012; Ambient Temp: 23.9°C; Tissue Temp: 22.7°C

Probe: ES3DV3 - SN3287; ConvF(5.06, 5.06, 5.06); Calibrated: 2/7/2012;

Sensor-Surface: 4mm (Mechanical Surface Detection)

Electronics: DAE4 Sn649; Calibrated: 2/20/2012

Phantom: SAM v5.0 front; Type: QD000P40CD; Serial: TP-1646

Measurement SW: DASY52, Version 52.8 (1); SEMCAD X Version 14.6.5 (6469)

1900 MHz System Verification

Area Scan (7x9x1): Measurement grid: dx=15mm, dy=15mm

Zoom Scan (5x5x7)/Cube 0: Measurement grid: dx=8mm, dy=8mm, dz=5mm

Input Power: 20.0 dBm (100 mW)

Peak SAR (extrapolated) = 7.789 mW/g

SAR(1 g) = 4.18 mW/g; SAR(10 g) = 2.17 mW/g

Deviation: 6.36%

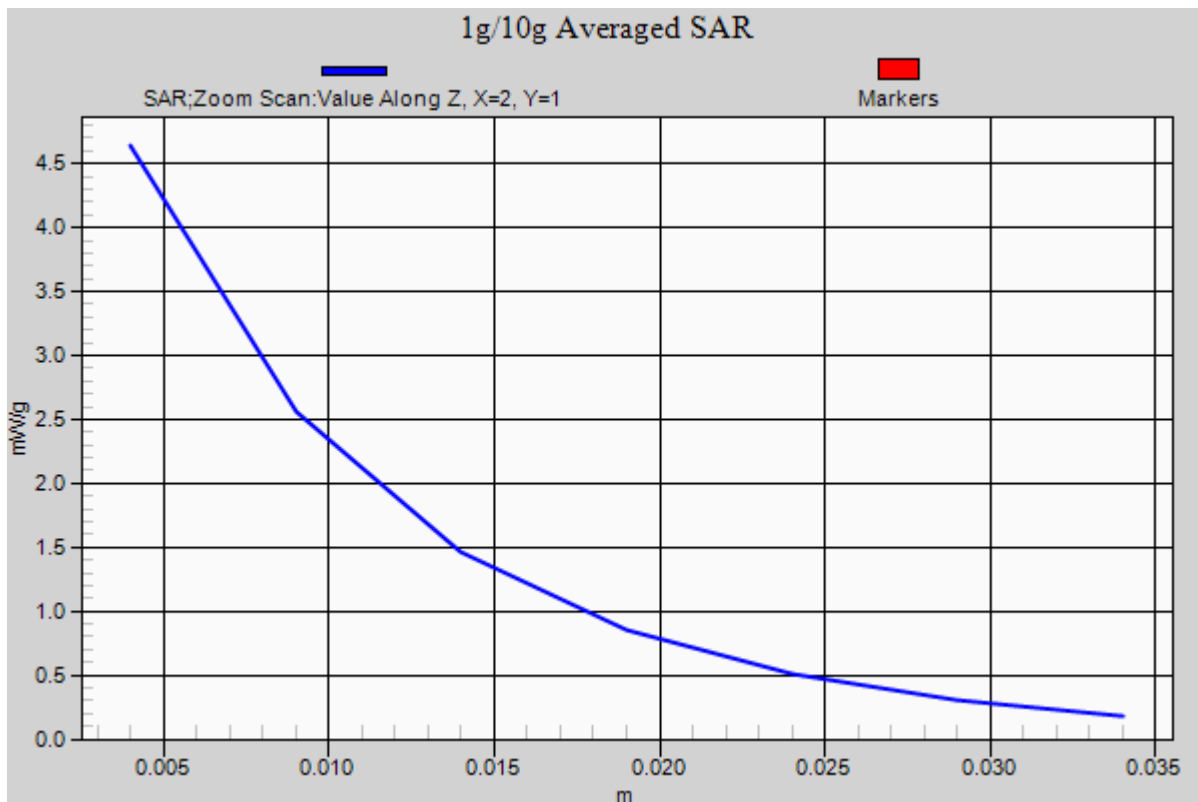

PCTEST ENGINEERING LABORATORY, INC.

DUT: SAR Dipole 2450 MHz; Type: D2450V2; Serial: 797

Communication System: CW; Frequency: 2450 MHz; Duty Cycle: 1:1

Medium: 2450 Head Medium parameters used:

$f = 2450$ MHz; $\sigma = 1.875$ mho/m; $\epsilon_r = 38.92$; $\rho = 1000$ kg/m³

Phantom section: Flat Section; Space: 1.0 cm

Test Date: 07-10-2012; Ambient Temp: 24.2°C; Tissue Temp: 24.1°C

Probe: ES3DV3 - SN3209; ConvF(4.46, 4.46, 4.46); Calibrated: 3/16/2012;

Sensor-Surface: 3mm (Mechanical Surface Detection)

Electronics: DAE4 Sn1323; Calibrated: 2/15/2012

Phantom: SAM Main; Type: SAM 4.0; Serial: TP-1114

Measurement SW: DASY4, Version 4.7 (80); SEMCAD X Version 14.6.5 (6469)

2450MHz System Verification

Area Scan (6x8x1): Measurement grid: dx=12mm, dy=12mm

Zoom Scan (7x7x7)/Cube 0: Measurement grid: dx=5mm, dy=5mm, dz=5mm

Input Power = 16 dBm (40 mW)

Peak SAR (extrapolated) = 4.560 mW/g

SAR(1 g) = 2.23 mW/g; SAR(10 g) = 1.04 mW/g

Deviation = 7.01%

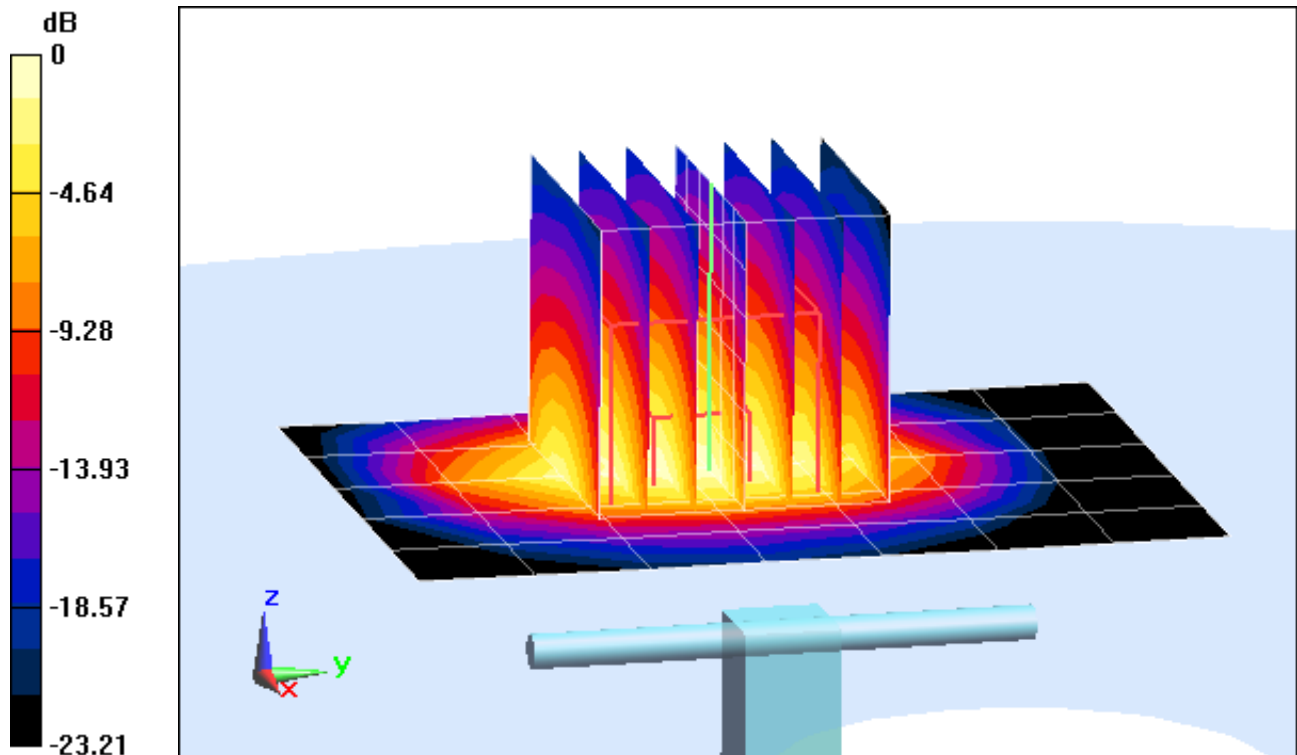

0 dB = 2.89 mW/g = 9.22 dB mW/g

PCTEST ENGINEERING LABORATORY, INC.

DUT: SAR Dipole 2450 MHz; Type: D2450V2; Serial: 797

Communication System: CW; Frequency: 2450 MHz; Duty Cycle: 1:1

Medium: 2450 Head Medium parameters used:

$f = 2450 \text{ MHz}$; $\sigma = 1.875 \text{ mho/m}$; $\epsilon_r = 38.92$; $\rho = 1000 \text{ kg/m}^3$

Phantom section: Flat Section; Space: 1.0 cm

Test Date: 07-10-2012; Ambient Temp: 24.2°C; Tissue Temp: 24.1°C

Probe: ES3DV3 - SN3209; ConvF(4.46, 4.46, 4.46); Calibrated: 3/16/2012;

Sensor-Surface: 3mm (Mechanical Surface Detection)

Electronics: DAE4 Sn1323; Calibrated: 2/15/2012

Phantom: SAM Main; Type: SAM 4.0; Serial: TP-1114

Measurement SW: DASY4, Version 4.7 (80); SEMCAD X Version 14.6.5 (6469)

2450MHz System Verification

Area Scan (6x8x1): Measurement grid: dx=12mm, dy=12mm

Zoom Scan (7x7x7)/Cube 0: Measurement grid: dx=5mm, dy=5mm, dz=5mm

Input Power = 16 dBm (40 mW)

Peak SAR (extrapolated) = 4.560 mW/g

SAR(1 g) = 2.23 mW/g; SAR(10 g) = 1.04 mW/g

Deviation = 7.01%

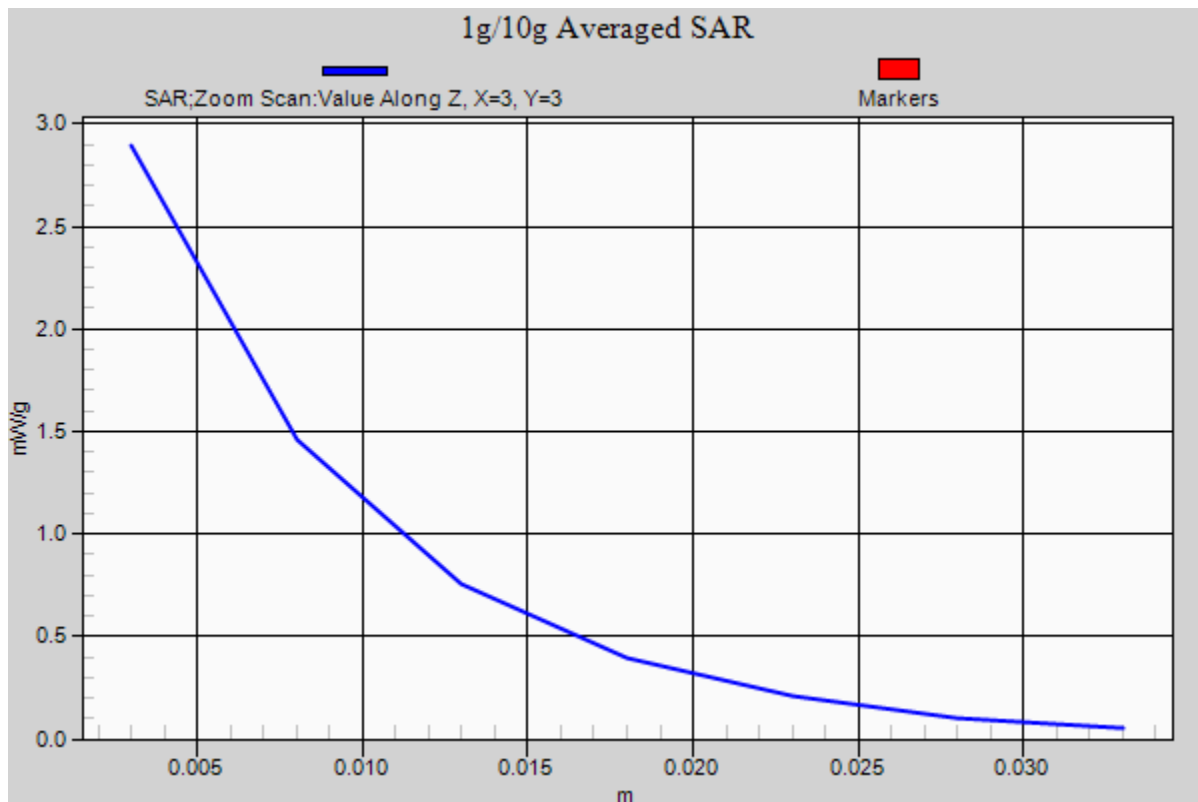

PCTEST ENGINEERING LABORATORY, INC.

DUT: Dipole 5200 MHz; Type: D5GHzV2; Serial: 1057

Communication System: CW; Frequency: 5200 MHz; Duty Cycle: 1:1

Medium: 5 GHz Head Medium parameters used:

$f = 5200 \text{ MHz}$; $\sigma = 4.458 \text{ mho/m}$; $\epsilon_r = 36.01$; $\rho = 1000 \text{ kg/m}^3$

Phantom section: Flat Section; Space: 1.0 cm

Test Date: 07-09-2012; Ambient Temp: 24.4°C; Tissue Temp: 23.3°C

Probe: EX3DV4 - SN3589; ConvF(4.59, 4.59, 4.59); Calibrated: 1/27/2012;

Sensor-Surface: 2mm (Mechanical Surface Detection)

Electronics: DAE4 Sn1323; Calibrated: 2/15/2012

Phantom: SAM Main; Type: SAM 4.0; Serial: TP-1114

Measurement SW: DASY4, Version 4.7 (80); SEMCAD X Version 14.6.5 (6469)

5200MHz System Verification

Area Scan (7x9x1): Measurement grid: dx=10mm, dy=10mm

Zoom Scan (7x7x11)/Cube 0: Measurement grid: dx=4mm, dy=4mm, dz=2mm

Input Power = 12.55 dBm (18 mW)

Peak SAR (extrapolated) = 6.476 mW/g

SAR(1 g) = 1.49 mW/g; SAR(10 g) = 0.404 mW/g

Deviation = 4.65%

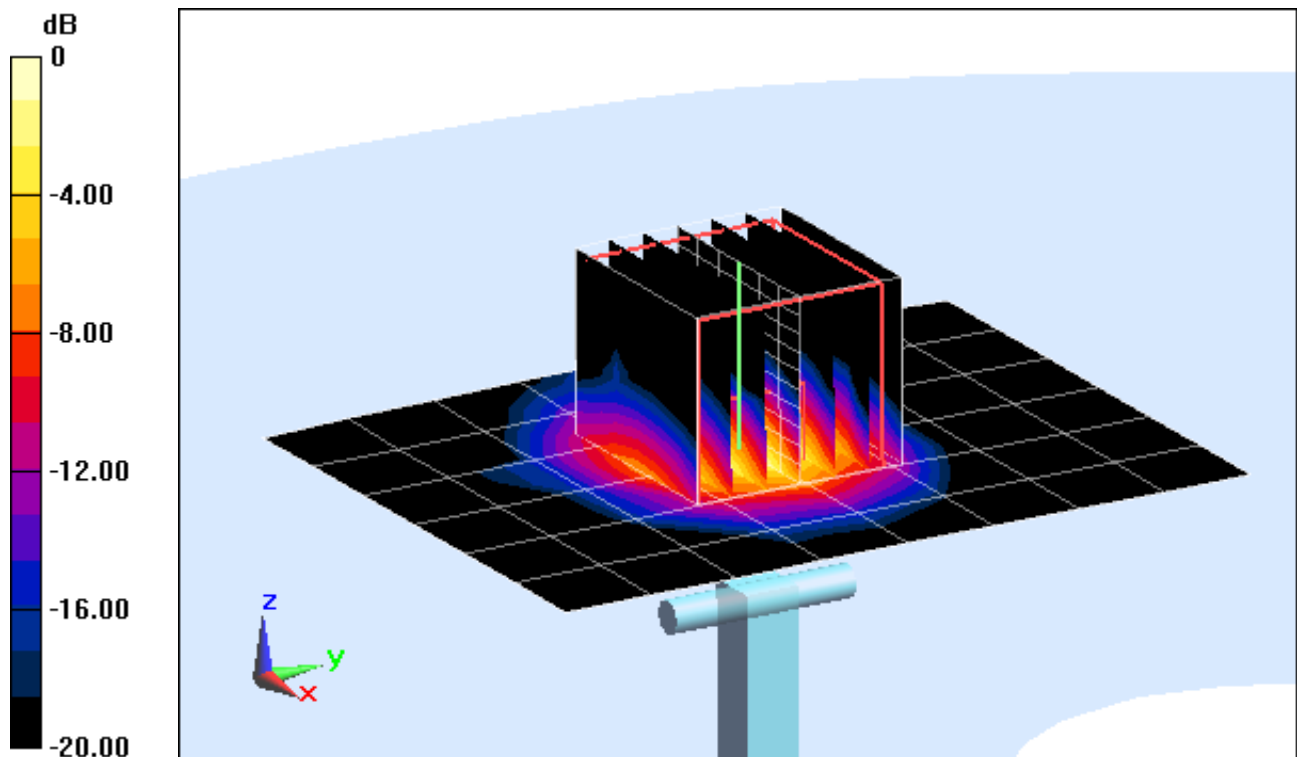

0 dB = 3.10 mW/g = 9.83 dB mW/g

PCTEST ENGINEERING LABORATORY, INC.

DUT: Dipole 5200 MHz; Type: D5GHzV2; Serial: 1057

Communication System: CW; Frequency: 5200 MHz; Duty Cycle: 1:1

Medium: 5 GHz Head Medium parameters used:

$f = 5200 \text{ MHz}$; $\sigma = 4.458 \text{ mho/m}$; $\epsilon_r = 36.01$; $\rho = 1000 \text{ kg/m}^3$

Phantom section: Flat Section; Space: 1.0 cm

Test Date: 07-09-2012; Ambient Temp: 24.4°C; Tissue Temp: 23.3°C

Probe: EX3DV4 - SN3589; ConvF(4.59, 4.59, 4.59); Calibrated: 1/27/2012;

Sensor-Surface: 2mm (Mechanical Surface Detection)

Electronics: DAE4 Sn1323; Calibrated: 2/15/2012

Phantom: SAM Main; Type: SAM 4.0; Serial: TP-1114

Measurement SW: DASY4, Version 4.7 (80); SEMCAD X Version 14.6.5 (6469)

5200MHz System Verification

Area Scan (7x9x1): Measurement grid: dx=10mm, dy=10mm

Zoom Scan (7x7x11)/Cube 0: Measurement grid: dx=4mm, dy=4mm, dz=2mm

Input Power = 12.55 dBm (18 mW)

Peak SAR (extrapolated) = 6.476 mW/g

SAR(1 g) = 1.49 mW/g; SAR(10 g) = 0.404 mW/g

Deviation = 4.65%

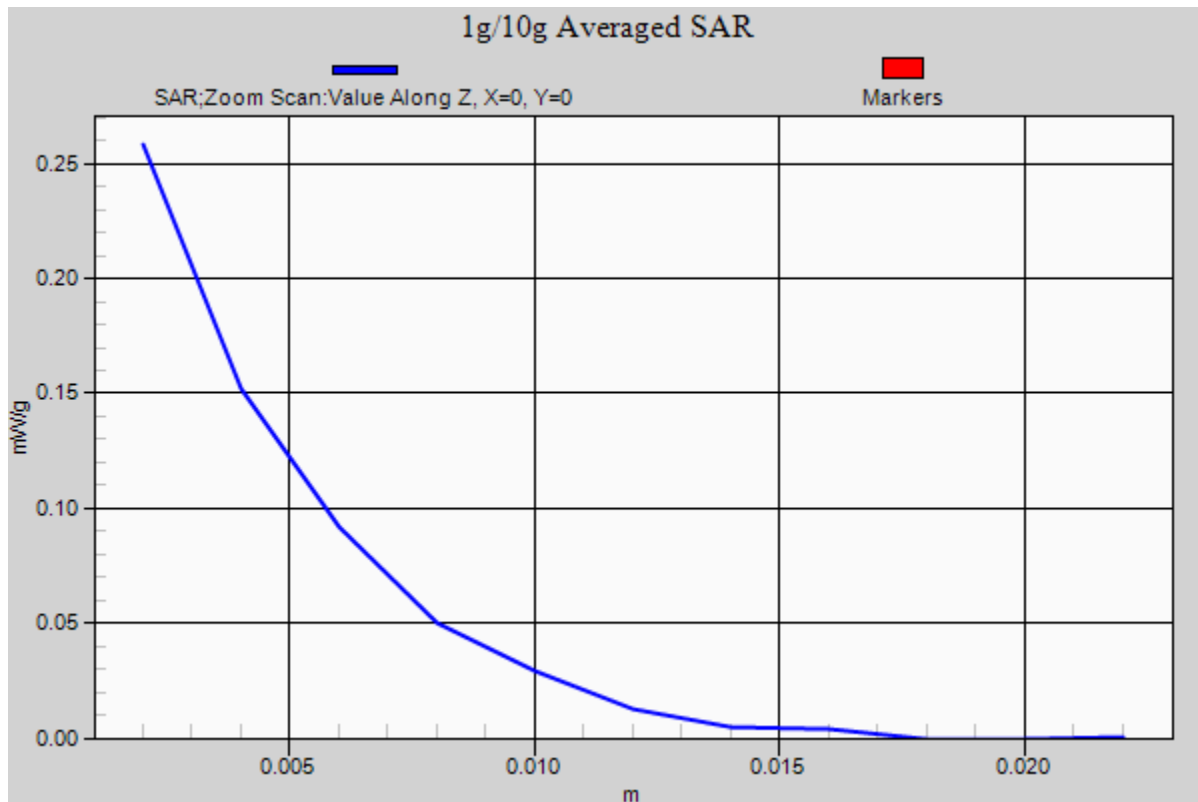

PCTEST ENGINEERING LABORATORY, INC.

DUT: Dipole 5500 MHz; Type: D5GHzV2; Serial: 1057

Communication System: CW; Frequency: 5500 MHz; Duty Cycle: 1:1

Medium: 5 GHz Head Medium parameters used:

$f = 5500 \text{ MHz}$; $\sigma = 4.743 \text{ mho/m}$; $\epsilon_r = 35.58$; $\rho = 1000 \text{ kg/m}^3$

Phantom section: Flat Section; Space: 1.0 cm

Test Date: 07-09-2012; Ambient Temp: 24.6°C; Tissue Temp: 23.5°C

Probe: EX3DV4 - SN3589; ConvF(4.33, 4.33, 4.33); Calibrated: 1/27/2012;

Sensor-Surface: 2mm (Mechanical Surface Detection)

Electronics: DAE4 Sn1323; Calibrated: 2/15/2012

Phantom: SAM Main; Type: SAM 4.0; Serial: TP-1114

Measurement SW: DASY4, Version 4.7 (80); SEMCAD X Version 14.6.5 (6469)

5500MHz System Verification

Area Scan (7x9x1): Measurement grid: dx=10mm, dy=10mm

Zoom Scan (7x7x11)/Cube 0: Measurement grid: dx=4mm, dy=4mm, dz=2mm

Input Power = 12.55 dBm (18 mW)

Peak SAR (extrapolated) = 6.645 mW/g

SAR(1 g) = 1.5 mW/g; SAR(10 g) = 0.396 mW/g

Deviation = -1.85%

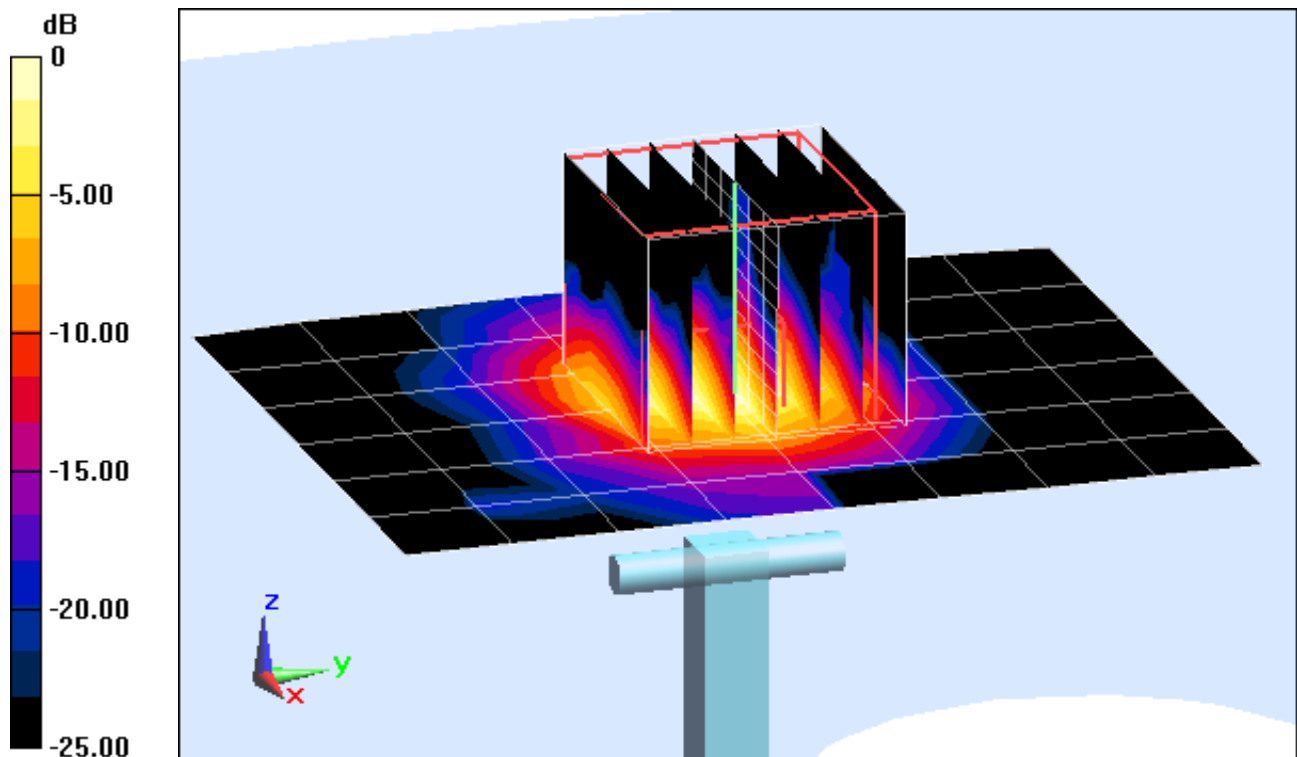

0 dB = 3.02 mW/g = 9.60 dB mW/g

PCTEST ENGINEERING LABORATORY, INC.

DUT: Dipole 5500 MHz; Type: D5GHzV2; Serial: 1057

Communication System: CW; Frequency: 5500 MHz; Duty Cycle: 1:1

Medium: 5 GHz Head Medium parameters used:

$f = 5500 \text{ MHz}$; $\sigma = 4.743 \text{ mho/m}$; $\epsilon_r = 35.58$; $\rho = 1000 \text{ kg/m}^3$

Phantom section: Flat Section; Space: 1.0 cm

Test Date: 07-09-2012; Ambient Temp: 24.6°C; Tissue Temp: 23.5°C

Probe: EX3DV4 - SN3589; ConvF(4.33, 4.33, 4.33); Calibrated: 1/27/2012;

Sensor-Surface: 2mm (Mechanical Surface Detection)

Electronics: DAE4 Sn1323; Calibrated: 2/15/2012

Phantom: SAM Main; Type: SAM 4.0; Serial: TP-1114

Measurement SW: DASY4, Version 4.7 (80); SEMCAD X Version 14.6.5 (6469)

5500MHz System Verification

Area Scan (7x9x1): Measurement grid: dx=10mm, dy=10mm

Zoom Scan (7x7x11)/Cube 0: Measurement grid: dx=4mm, dy=4mm, dz=2mm

Input Power = 12.55 dBm (18 mW)

Peak SAR (extrapolated) = 6.645 mW/g

SAR(1 g) = 1.5 mW/g; SAR(10 g) = 0.396 mW/g

Deviation = -1.85%

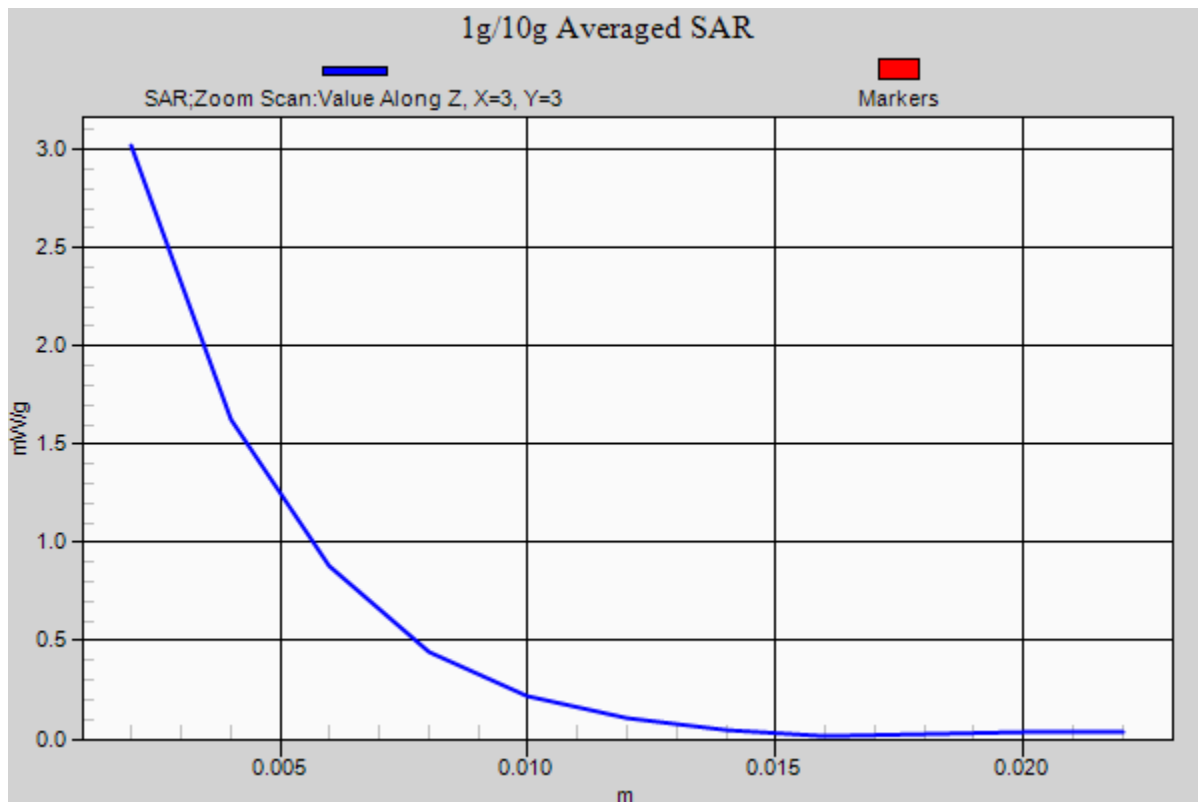

PCTEST ENGINEERING LABORATORY, INC.

DUT: Dipole 5800 MHz; Type: D5GHzV2; Serial: 1057

Communication System: CW; Frequency: 5800 MHz; Duty Cycle: 1:1

Medium: 5 GHz Head Medium parameters used:

$f = 5800 \text{ MHz}$; $\sigma = 5.052 \text{ mho/m}$; $\epsilon_r = 35.34$; $\rho = 1000 \text{ kg/m}^3$

Phantom section: Flat Section; Space: 1.0 cm

Test Date: 07-09-2012; Ambient Temp: 24.8°C; Tissue Temp: 23.7°C

Probe: EX3DV4 - SN3589; ConvF(4.05, 4.05, 4.05); Calibrated: 1/27/2012;

Sensor-Surface: 2mm (Mechanical Surface Detection)

Electronics: DAE4 Sn1323; Calibrated: 2/15/2012

Phantom: SAM Main; Type: SAM 4.0; Serial: TP-1114

Measurement SW: DASY4, Version 4.7 (80); SEMCAD X Version 14.6.5 (6469)

5800MHz System Verification

Area Scan (7x9x1): Measurement grid: dx=10mm, dy=10mm

Zoom Scan (7x7x11)/Cube 0: Measurement grid: dx=4mm, dy=4mm, dz=2mm

Input Power = 12.55 dBm (18 mW)

Peak SAR (extrapolated) = 6.805 mW/g

SAR(1 g) = 1.48 mW/g; SAR(10 g) = 0.391 mW/g

Deviation = 3.42%

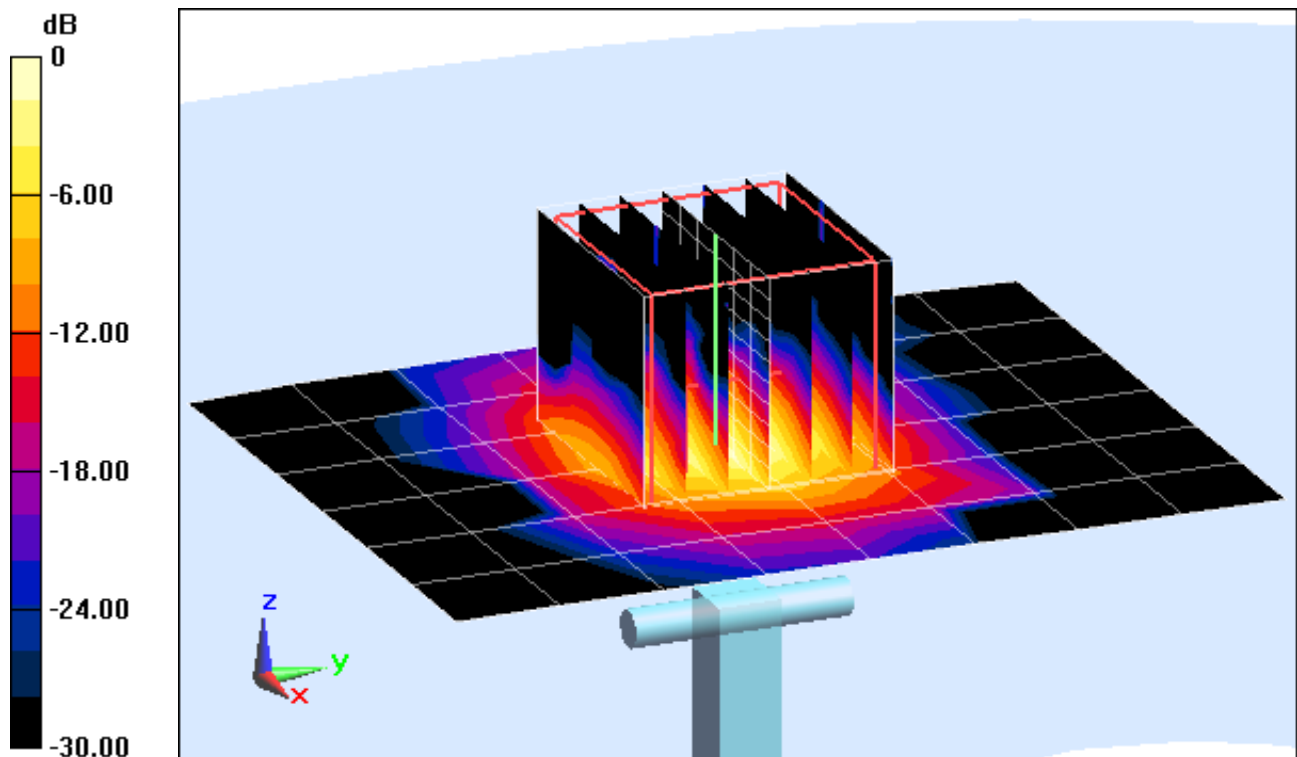

0 dB = 3.22 mW/g = 10.16 dB mW/g

PCTEST ENGINEERING LABORATORY, INC.

DUT: Dipole 5800 MHz; Type: D5GHzV2; Serial: 1057

Communication System: CW; Frequency: 5800 MHz; Duty Cycle: 1:1

Medium: 5 GHz Head Medium parameters used:

$f = 5800 \text{ MHz}$; $\sigma = 5.052 \text{ mho/m}$; $\epsilon_r = 35.34$; $\rho = 1000 \text{ kg/m}^3$

Phantom section: Flat Section; Space: 1.0 cm

Test Date: 07-09-2012; Ambient Temp: 24.8°C; Tissue Temp: 23.7°C

Probe: EX3DV4 - SN3589; ConvF(4.05, 4.05, 4.05); Calibrated: 1/27/2012;

Sensor-Surface: 2mm (Mechanical Surface Detection)

Electronics: DAE4 Sn1323; Calibrated: 2/15/2012

Phantom: SAM Main; Type: SAM 4.0; Serial: TP-1114

Measurement SW: DASY4, Version 4.7 (80); SEMCAD X Version 14.6.5 (6469)

5800MHz System Verification

Area Scan (7x9x1): Measurement grid: dx=10mm, dy=10mm

Zoom Scan (7x7x11)/Cube 0: Measurement grid: dx=4mm, dy=4mm, dz=2mm

Input Power = 12.55 dBm (18 mW)

Peak SAR (extrapolated) = 6.805 mW/g

SAR(1 g) = 1.48 mW/g; SAR(10 g) = 0.391 mW/g

Deviation = 3.42%

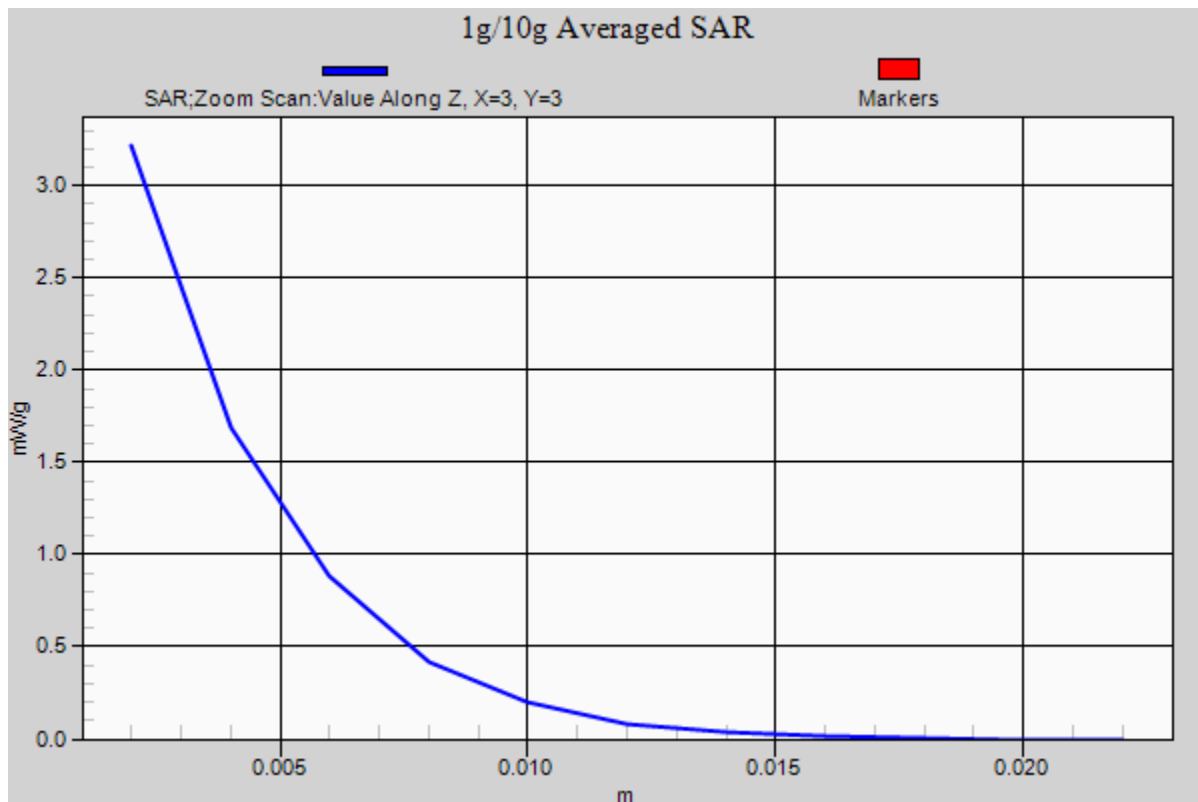

PCTEST ENGINEERING LABORATORY, INC.

DUT: Dipole 750 MHz; Type: D750V3; Serial: 1003

Communication System: CW; Frequency: 750 MHz; Duty Cycle: 1:1

Medium: 740 Body Medium parameters used (interpolated):

$f = 750 \text{ MHz}$; $\sigma = 0.991 \text{ mho/m}$; $\epsilon_r = 54.427$; $\rho = 1000 \text{ kg/m}^3$

Phantom section: Flat Section; Space; 1.5 cm

Test Date: 07-11-2012; Ambient Temp: 24.0°C; Tissue Temp: 22.8°C

Probe: ES3DV2 - SN3022; ConvF(6.11, 6.11, 6.11); Calibrated: 8/25/2011;

Sensor-Surface: 4mm (Mechanical Surface Detection)

Electronics: DAE4 Sn665; Calibrated: 4/19/2012

Phantom: SAM with CRP; Type: SAM; Serial: TP1375

Measurement SW: DASY4, Version 4.7 (80); SEMCAD X Version 14.6.5 (6469)

750MHz System Verification

Area Scan (7x13x1): Measurement grid: dx=15mm, dy=15mm

Zoom Scan (5x5x7)/Cube 0: Measurement grid: dx=8mm, dy=8mm, dz=5mm

Input Power = 20 dBm (100 mW)

Peak SAR (extrapolated) = 1.307 mW/g

SAR(1 g) = 0.890 mW/g; SAR(10 g) = 0.587 mW/g

Deviation = 2.06%

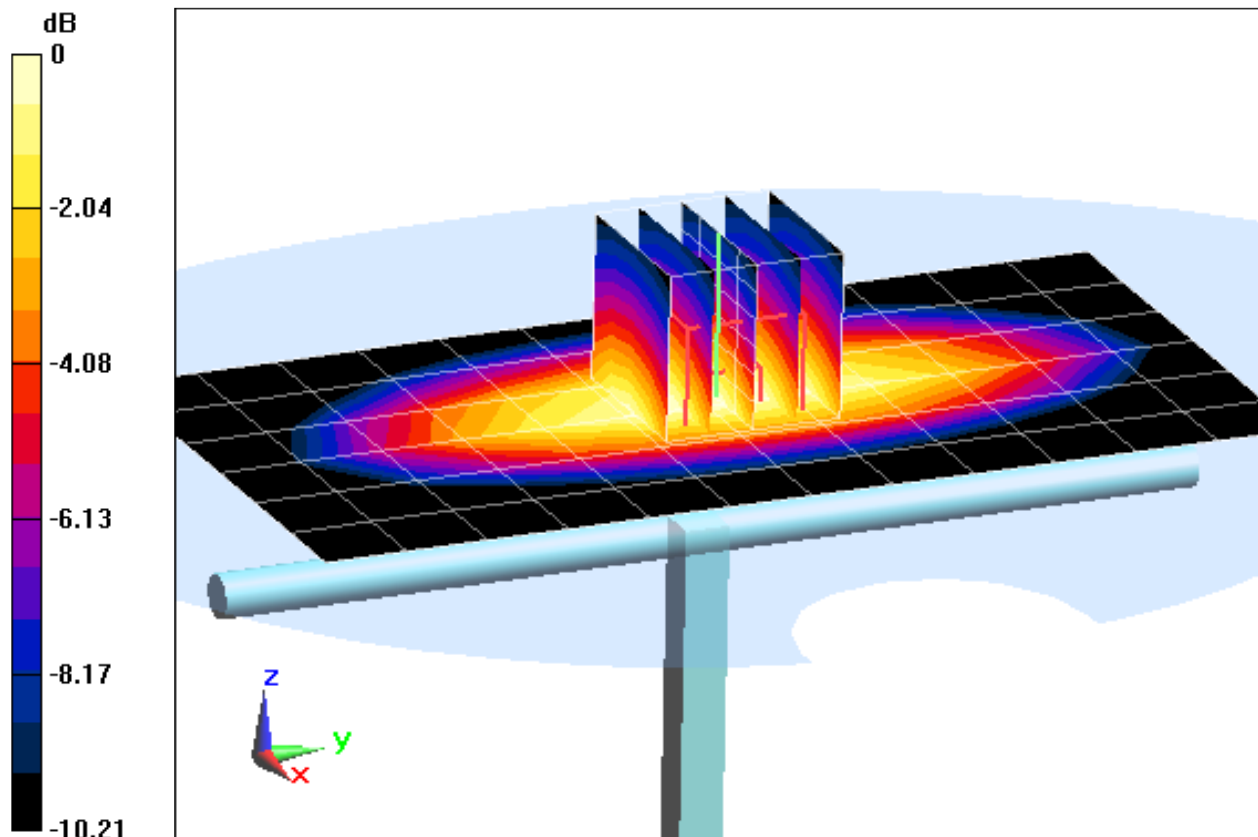

0 dB = 0.961 mW/g = -0.35 dB mW/g

PCTEST ENGINEERING LABORATORY, INC.

DUT: Dipole 750 MHz; Type: D750V3; Serial: 1003

Communication System: CW; Frequency: 750 MHz; Duty Cycle: 1:1

Medium: 740 Body Medium parameters used (interpolated):

$f = 750 \text{ MHz}$; $\sigma = 0.991 \text{ mho/m}$; $\epsilon_r = 54.427$; $\rho = 1000 \text{ kg/m}^3$

Phantom section: Flat Section; Space; 1.5 cm

Test Date: 07-11-2012; Ambient Temp: 24.0°C; Tissue Temp: 22.8°C

Probe: ES3DV2 - SN3022; ConvF(6.11, 6.11, 6.11); Calibrated: 8/25/2011;

Sensor-Surface: 4mm (Mechanical Surface Detection)

Electronics: DAE4 Sn665; Calibrated: 4/19/2012

Phantom: SAM with CRP; Type: SAM; Serial: TP1375

Measurement SW: DASY4, Version 4.7 (80); SEMCAD X Version 14.6.5 (6469)

750MHz System Verification

Area Scan (7x13x1): Measurement grid: dx=15mm, dy=15mm

Zoom Scan (5x5x7)/Cube 0: Measurement grid: dx=8mm, dy=8mm, dz=5mm

Input Power = 20 dBm (100 mW)

Peak SAR (extrapolated) = 1.307 mW/g

SAR(1 g) = 0.890 mW/g; SAR(10 g) = 0.587 mW/g

Deviation = 2.06%

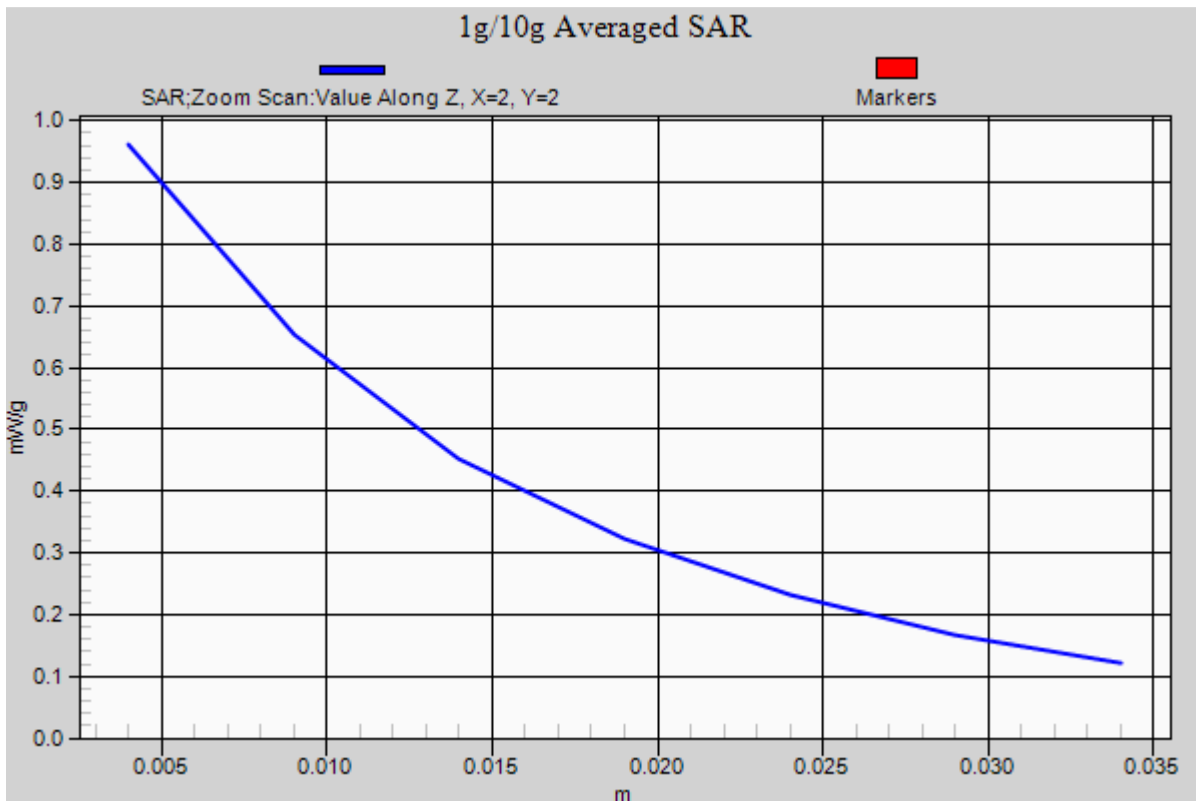

PCTEST ENGINEERING LABORATORY, INC.

DUT: Dipole 835 MHz; Type: D835V2; Serial: 4d119

Communication System: CW; Frequency: 835 MHz; Duty Cycle: 1:1

Medium: 835 Body Medium parameters used:

$f = 835 \text{ MHz}$; $\sigma = 0.975 \text{ mho/m}$; $\epsilon_r = 52.59$; $\rho = 1000 \text{ kg/m}^3$

Phantom section: Flat Section; Space: 1.5 cm

Test Date: 07-09-2012; Ambient Temp: 24.9°C; Tissue Temp: 23.3C

Probe: ES3DV3 - SN3258; ConvF(6.06, 6.06, 6.06); Calibrated: 2/21/2012;

Sensor-Surface: 4mm (Mechanical Surface Detection)

Electronics: DAE4 Sn1272; Calibrated: 1/18/2012

Phantom: SAM Main; Type: SAM 4.0; Serial: TP-1406

Measurement SW: DASY4, Version 4.7 (80); SEMCAD X Version 14.6.5 (6469)

835MHz System Verification

Area Scan (7x13x1): Measurement grid: dx=15mm, dy=15mm

Zoom Scan (5x5x7)/Cube 0: Measurement grid: dx=8mm, dy=8mm, dz=5mm

Input Power = 20 dBm (100 mW)

Peak SAR (extrapolated) = 1.461 mW/g

SAR(1 g) = 1 mW/g; SAR(10 g) = 0.664 mW/g

Deviation = 4.60%

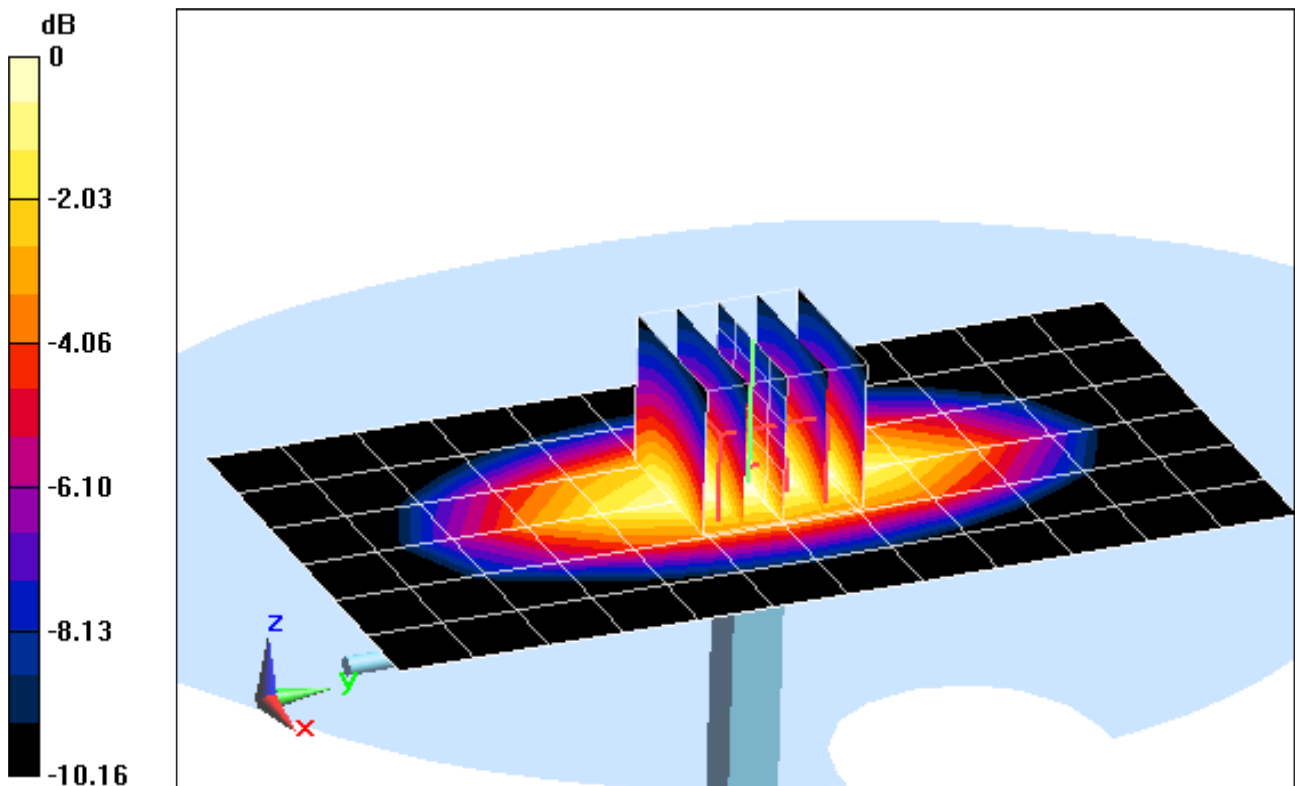

0 dB = 1.09 mW/g = 0.75 dB mW/g

PCTEST ENGINEERING LABORATORY, INC.

DUT: Dipole 835 MHz; Type: D835V2; Serial: 4d119

Communication System: CW; Frequency: 835 MHz; Duty Cycle: 1:1

Medium: 835 Body Medium parameters used:

$f = 835 \text{ MHz}$; $\sigma = 0.975 \text{ mho/m}$; $\epsilon_r = 52.59$; $\rho = 1000 \text{ kg/m}^3$

Phantom section: Flat Section; Space: 1.5 cm

Test Date: 07-09-2012; Ambient Temp: 24.9°C; Tissue Temp: 23.3C

Probe: ES3DV3 - SN3258; ConvF(6.06, 6.06, 6.06); Calibrated: 2/21/2012;

Sensor-Surface: 4mm (Mechanical Surface Detection)

Electronics: DAE4 Sn1272; Calibrated: 1/18/2012

Phantom: SAM Main; Type: SAM 4.0; Serial: TP-1406

Measurement SW: DASY4, Version 4.7 (80); SEMCAD X Version 14.6.5 (6469)

835MHz System Verification

Area Scan (7x13x1): Measurement grid: dx=15mm, dy=15mm

Zoom Scan (5x5x7)/Cube 0: Measurement grid: dx=8mm, dy=8mm, dz=5mm

Input Power = 20 dBm (100 mW)

Peak SAR (extrapolated) = 1.461 mW/g

SAR(1 g) = 1 mW/g; SAR(10 g) = 0.664 mW/g

Deviation = 4.60%

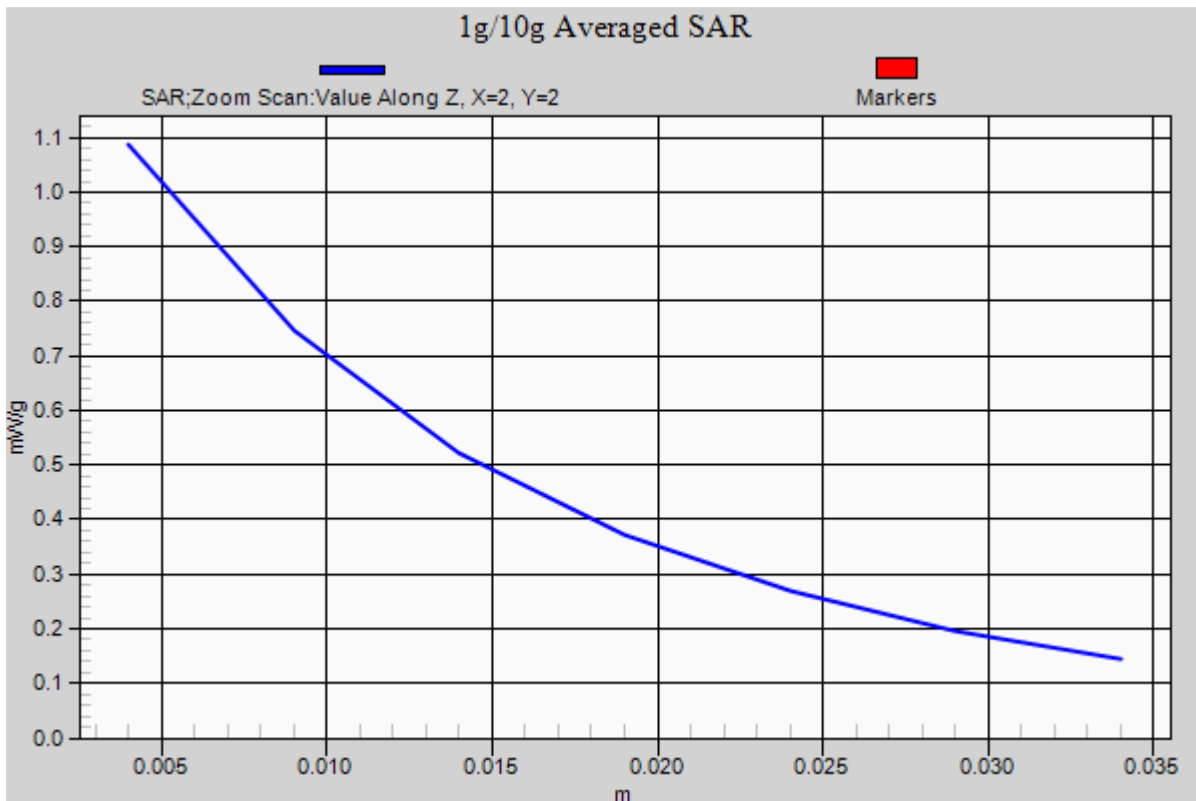

PCTEST ENGINEERING LABORATORY, INC.

DUT: Dipole 1750 MHz; Type: D1765V2; Serial: 1008

Communication System: CW; Frequency: 1750 MHz; Duty Cycle: 1:1
Medium: 1750 Body Medium parameters used:

$f = 1750 \text{ MHz}$; $\sigma = 1.446 \text{ mho/m}$; $\epsilon_r = 51.78$; $\rho = 1000 \text{ kg/m}^3$

Phantom section: Flat Section; Space: 1.0 cm

Test Date: 07-06-2012; Ambient Temp: 23.8°C; Tissue Temp: 22.9°C

Probe: ES3DV2 - SN3022; ConvF(4.64, 4.64, 4.64); Calibrated: 8/25/2011;
Sensor-Surface: 4mm (Mechanical Surface Detection)

Electronics: DAE4 Sn665; Calibrated: 4/19/2012

Phantom: SAM Sub Dasy B; Type: SAM 5.0; Serial: TP-1626

Measurement SW: DASY4, Version 4.7 (80); SEMCAD X Version 14.6.5 (6469)

1750 MHz System Verification

Area Scan (6x6x1): Measurement grid: dx=15mm, dy=15mm

Zoom Scan (5x5x7)/Cube 0: Measurement grid: dx=8mm, dy=8mm, dz=5mm

Input Power = 20 dBm (100 mW)

Peak SAR (extrapolated) = 7.051 mW/g

SAR(1 g) = 3.94 mW/g; SAR(10 g) = 2.06 mW/g

Deviation = 5.35%

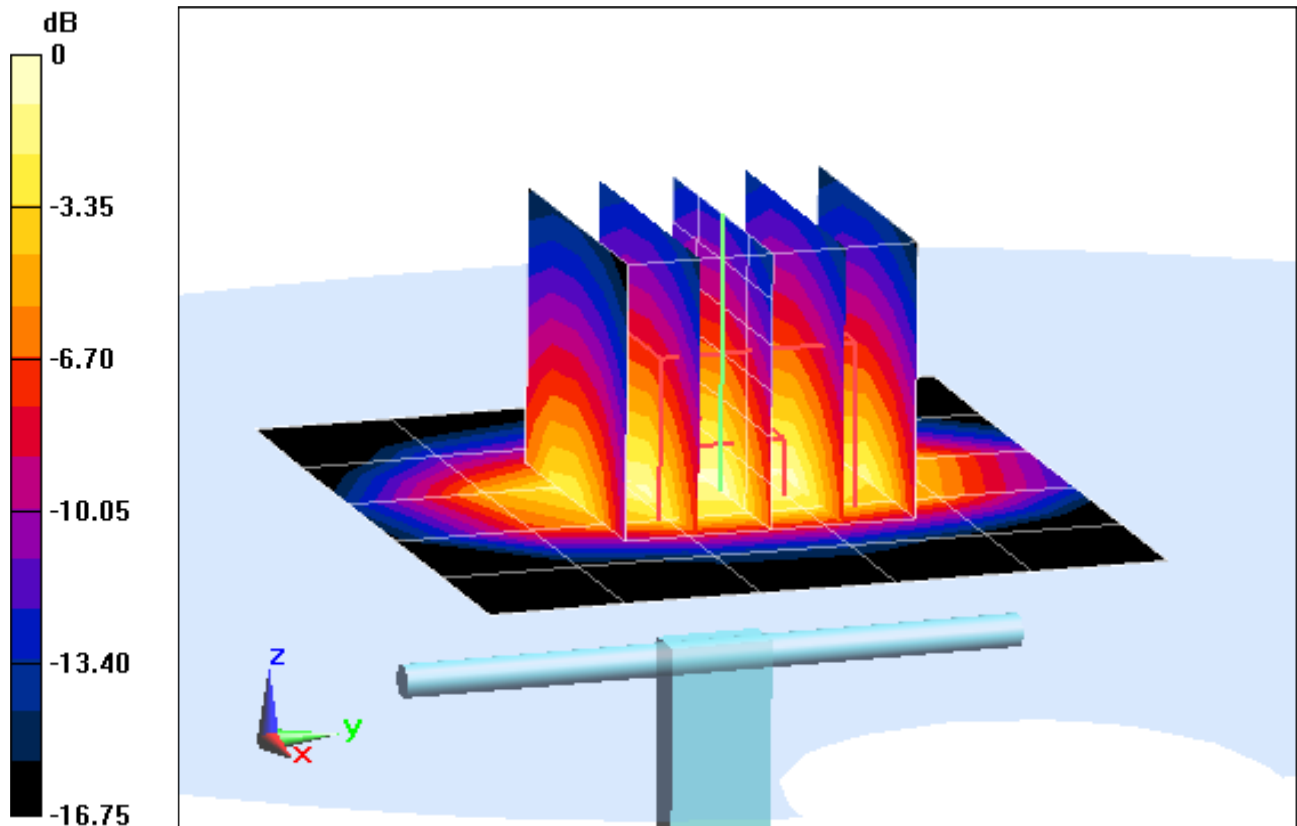

0 dB = 4.32 mW/g = 12.71 dB mW/g

PCTEST ENGINEERING LABORATORY, INC.

DUT: Dipole 1750 MHz; Type: D1765V2; Serial: 1008

Communication System: CW; Frequency: 1750 MHz; Duty Cycle: 1:1
Medium: 1750 Body Medium parameters used:

$f = 1750 \text{ MHz}$; $\sigma = 1.446 \text{ mho/m}$; $\epsilon_r = 51.78$; $\rho = 1000 \text{ kg/m}^3$

Phantom section: Flat Section; Space: 1.0 cm

Test Date: 07-06-2012; Ambient Temp: 23.8°C; Tissue Temp: 22.9°C

Probe: ES3DV2 - SN3022; ConvF(4.64, 4.64, 4.64); Calibrated: 8/25/2011;

Sensor-Surface: 4mm (Mechanical Surface Detection)

Electronics: DAE4 Sn665; Calibrated: 4/19/2012

Phantom: SAM Sub Dasy B; Type: SAM 5.0; Serial: TP-1626

Measurement SW: DASY4, Version 4.7 (80); SEMCAD X Version 14.6.5 (6469)

1750 MHz System Verification

Area Scan (6x6x1): Measurement grid: dx=15mm, dy=15mm

Zoom Scan (5x5x7)/Cube 0: Measurement grid: dx=8mm, dy=8mm, dz=5mm

Input Power = 20 dBm (100 mW)

Peak SAR (extrapolated) = 7.051 mW/g

SAR(1 g) = 3.94 mW/g; SAR(10 g) = 2.06 mW/g

Deviation = 5.35%

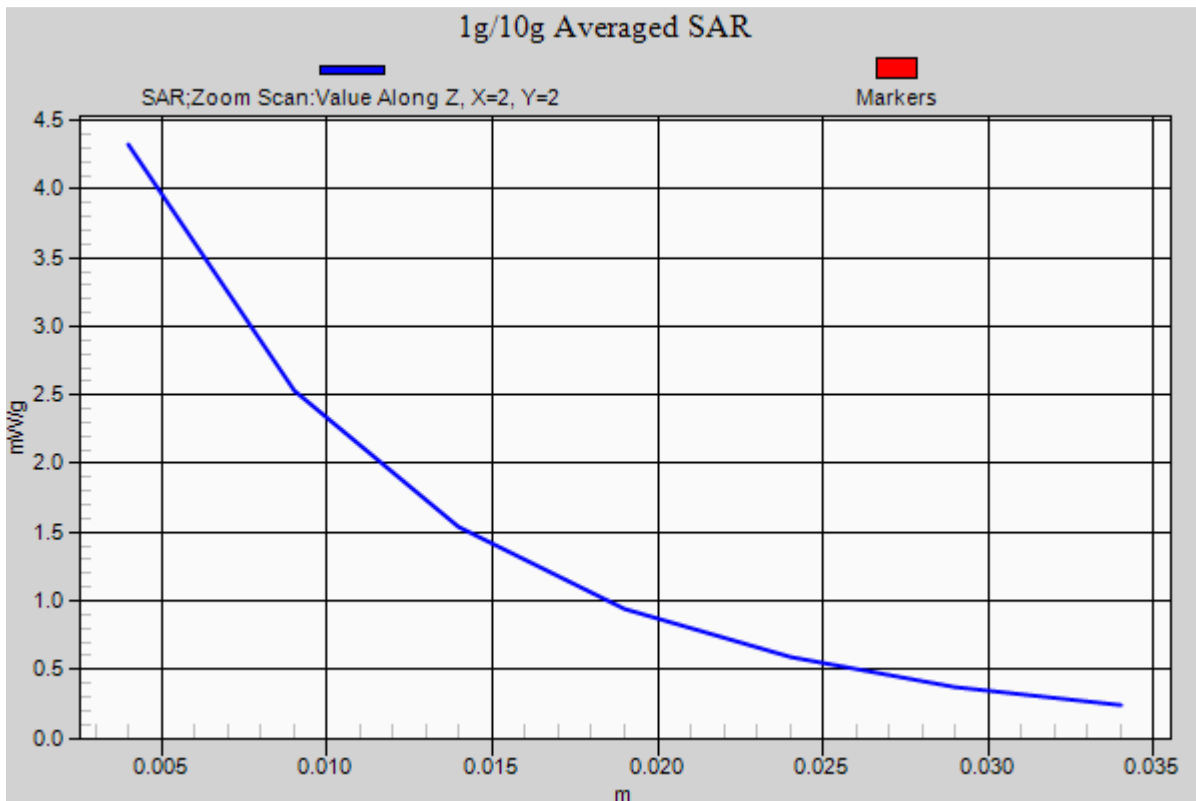

PCTEST ENGINEERING LABORATORY, INC.

DUT: Dipole 1900 MHz; Type: D1900V2; Serial: 5d080

Communication System: CW; Frequency: 1900 MHz; Duty Cycle: 1:1

Medium: 1900 Body Medium parameters used (interpolated):

$f = 1900 \text{ MHz}$; $\sigma = 1.51 \text{ mho/m}$; $\epsilon_r = 51.8$; $\rho = 1000 \text{ kg/m}^3$

Phantom section: Flat Section; Space: 1.0 cm

Test Date: 07-09-2012; Ambient Temp: 23.7°C; Tissue Temp: 24.8°C

Probe: ES3DV2 - SN3022; ConvF(4.41, 4.41, 4.41); Calibrated: 8/25/2011;

Sensor-Surface: 4mm (Mechanical Surface Detection)

Electronics: DAE4 Sn665; Calibrated: 4/19/2012

Phantom: SAM Sub Dasy B; Type: SAM 5.0; Serial: TP-1626

Measurement SW: DASY4, Version 4.7 (80); SEMCAD X Version 14.6.5 (6469)

1900MHz System Verification

Area Scan (5x7x1): Measurement grid: dx=15mm, dy=15mm

Zoom Scan (5x5x7)/Cube 0: Measurement grid: dx=8mm, dy=8mm, dz=5mm

Input Power = 20 dBm (100 mW)

Peak SAR (extrapolated) = 7.222 mW/g

SAR(1 g) = 4.23 mW/g; SAR(10 g) = 2.29 mW/g

Deviation = 3.42%

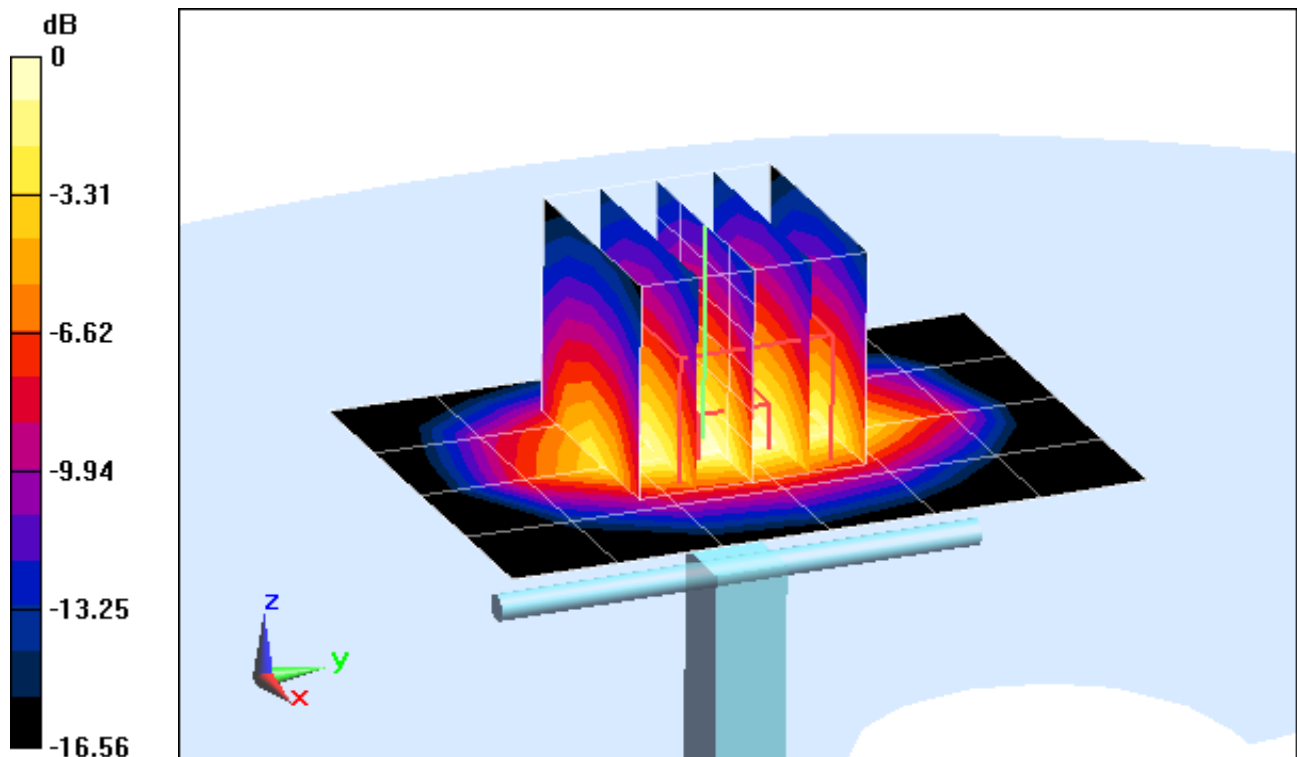

0 dB = 4.72 mW/g = 13.48 dB mW/g

PCTEST ENGINEERING LABORATORY, INC.

DUT: Dipole 1900 MHz; Type: D1900V2; Serial: 5d080

Communication System: CW; Frequency: 1900 MHz; Duty Cycle: 1:1

Medium: 1900 Body Medium parameters used (interpolated):

$f = 1900 \text{ MHz}$; $\sigma = 1.51 \text{ mho/m}$; $\epsilon_r = 51.8$; $\rho = 1000 \text{ kg/m}^3$

Phantom section: Flat Section; Space: 1.0 cm

Test Date: 07-09-2012; Ambient Temp: 23.7°C; Tissue Temp: 24.8°C

Probe: ES3DV2 - SN3022; ConvF(4.41, 4.41, 4.41); Calibrated: 8/25/2011;

Sensor-Surface: 4mm (Mechanical Surface Detection)

Electronics: DAE4 Sn665; Calibrated: 4/19/2012

Phantom: SAM Sub Dasy B; Type: SAM 5.0; Serial: TP-1626

Measurement SW: DASY4, Version 4.7 (80); SEMCAD X Version 14.6.5 (6469)

1900MHz System Verification

Area Scan (5x7x1): Measurement grid: dx=15mm, dy=15mm

Zoom Scan (5x5x7)/Cube 0: Measurement grid: dx=8mm, dy=8mm, dz=5mm

Input Power = 20 dBm (100 mW)

Peak SAR (extrapolated) = 7.222 mW/g

SAR(1 g) = 4.23 mW/g; SAR(10 g) = 2.29 mW/g

Deviation = 3.42%

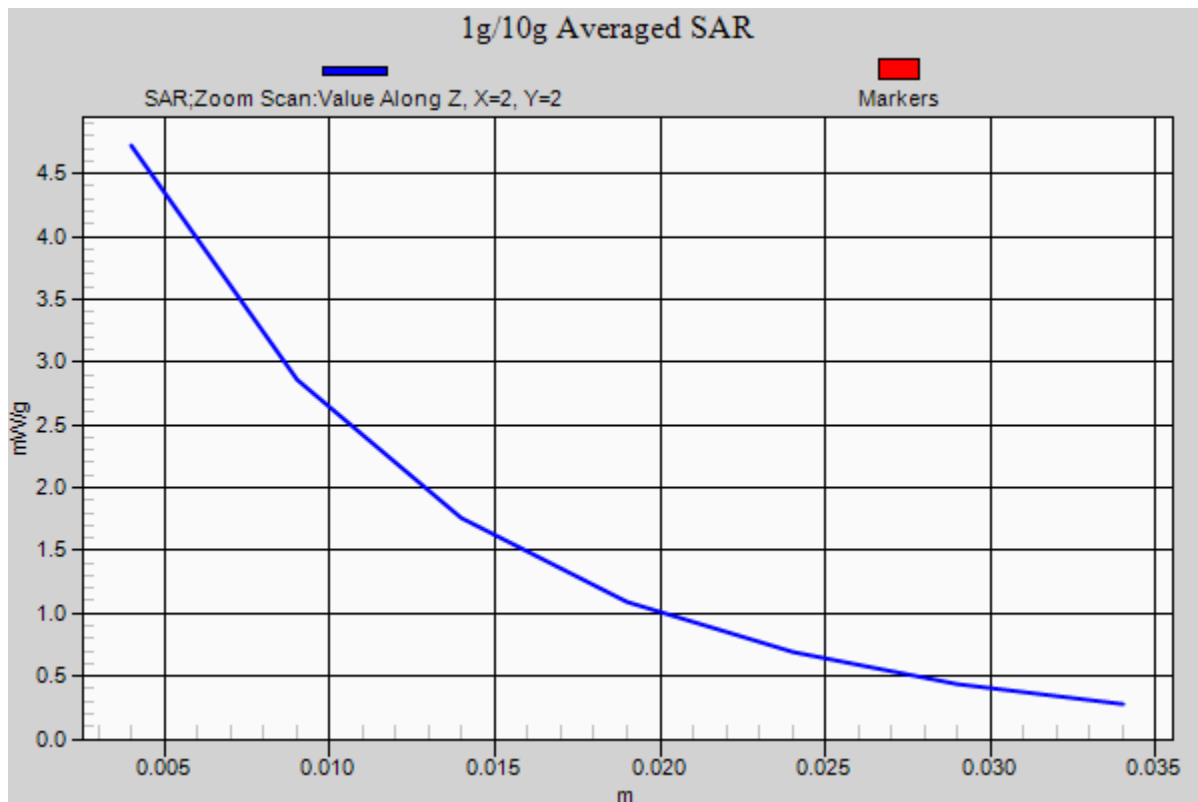

PCTEST ENGINEERING LABORATORY, INC.

DUT: SAR Dipole 2450 MHz; Type: D2450V2; Serial: 797

Communication System: CW; Frequency: 2450 MHz; Duty Cycle: 1:1

Medium: 2450 Body Medium parameters used:

$f = 2450$ MHz; $\sigma = 1.889$ mho/m; $\epsilon_r = 52.69$; $\rho = 1000$ kg/m³

Phantom section: Flat Section; Space: 1.0 cm

Test Date: 07-09-2012; Ambient Temp: 24.6°C; Tissue Temp: 24.0°C

Probe: ES3DV3 - SN3209; ConvF(4.23, 4.23, 4.23); Calibrated: 3/16/2012;

Sensor-Surface: 3mm (Mechanical Surface Detection)

Electronics: DAE4 Sn1323; Calibrated: 2/15/2012

Phantom: SAM Sub; Type: SAM 4.0; Serial: TP-1357

Measurement SW: DASY4, Version 4.7 (80); SEMCAD X Version 14.6.5 (6469)

2450MHz System Verification

Area Scan (6x8x1): Measurement grid: dx=12mm, dy=12mm

Zoom Scan (7x7x7)/Cube 0: Measurement grid: dx=5mm, dy=5mm, dz=5mm

Input Power = 20 dBm (100 mW)

Peak SAR (extrapolated) = 10.824 mW/g

SAR(1 g) = 5.19 mW/g; SAR(10 g) = 2.41 mW/g

Deviation = 2.17%

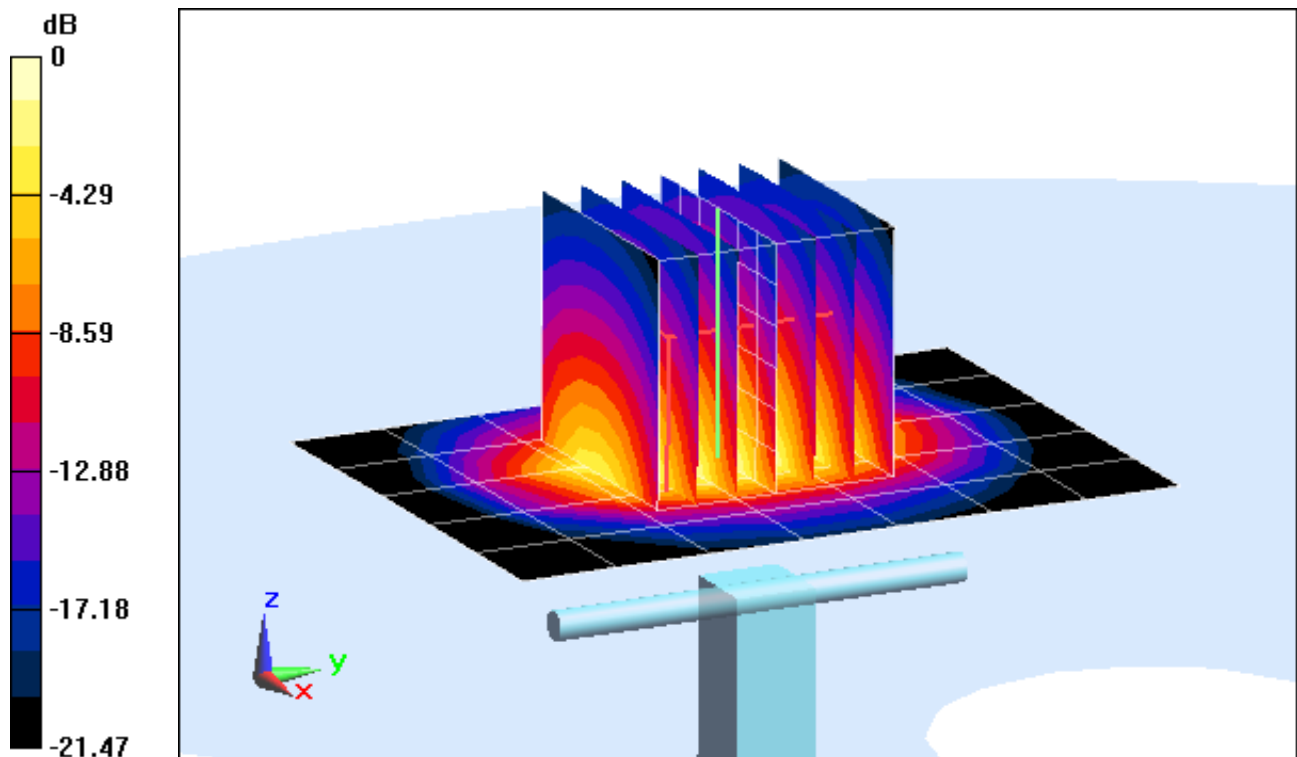

0 dB = 6.67 mW/g = 16.48 dB mW/g

PCTEST ENGINEERING LABORATORY, INC.

DUT: SAR Dipole 2450 MHz; Type: D2450V2; Serial: 797

Communication System: CW; Frequency: 2450 MHz; Duty Cycle: 1:1

Medium: 2450 Body Medium parameters used:

$f = 2450 \text{ MHz}$; $\sigma = 1.889 \text{ mho/m}$; $\epsilon_r = 52.69$; $\rho = 1000 \text{ kg/m}^3$

Phantom section: Flat Section; Space: 1.0 cm

Test Date: 07-09-2012; Ambient Temp: 24.6°C; Tissue Temp: 24.0°C

Probe: ES3DV3 - SN3209; ConvF(4.23, 4.23, 4.23); Calibrated: 3/16/2012;

Sensor-Surface: 3mm (Mechanical Surface Detection)

Electronics: DAE4 Sn1323; Calibrated: 2/15/2012

Phantom: SAM Sub; Type: SAM 4.0; Serial: TP-1357

Measurement SW: DASY4, Version 4.7 (80); SEMCAD X Version 14.6.5 (6469)

2450MHz System Verification

Area Scan (6x8x1): Measurement grid: dx=12mm, dy=12mm

Zoom Scan (7x7x7)/Cube 0: Measurement grid: dx=5mm, dy=5mm, dz=5mm

Input Power = 20 dBm (100 mW)

Peak SAR (extrapolated) = 10.824 mW/g

SAR(1 g) = 5.19 mW/g; SAR(10 g) = 2.41 mW/g

Deviation = 2.17%

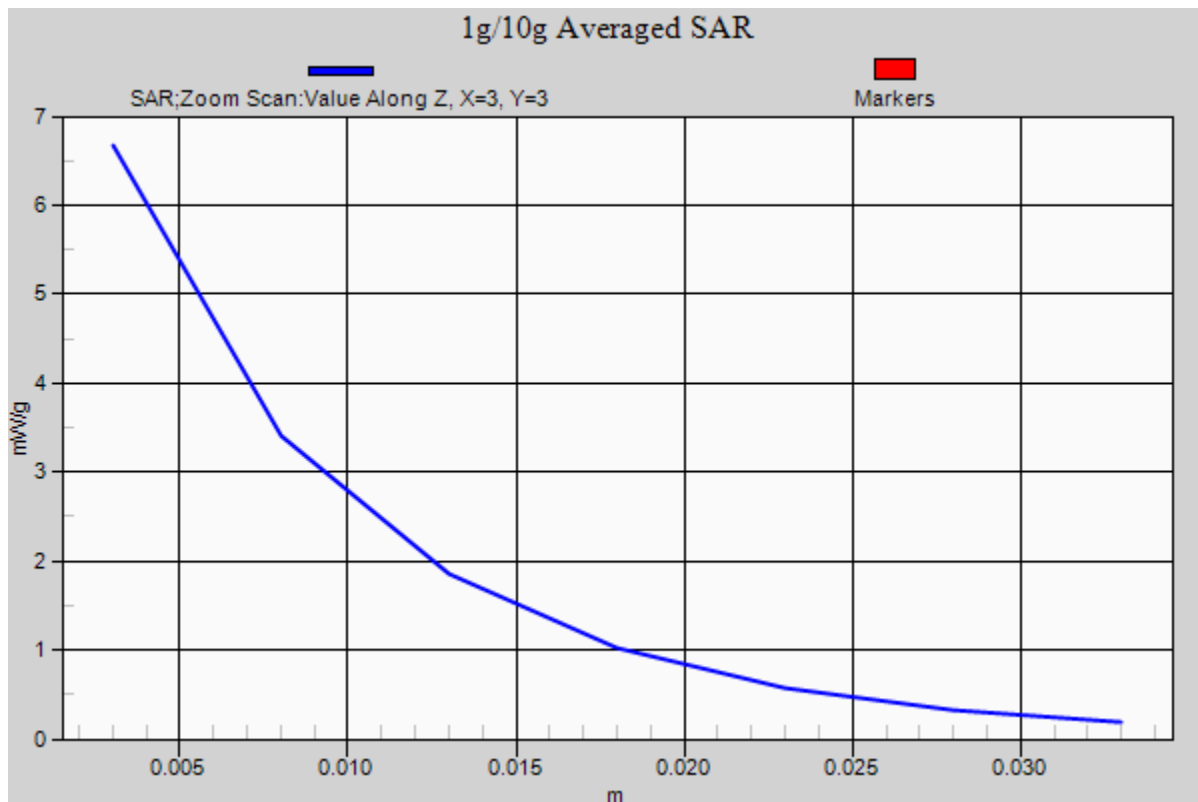

PCTEST ENGINEERING LABORATORY, INC.

DUT: Dipole 5200 MHz; Type: D5GHzV2; Serial: 1057

Communication System: CW; Frequency: 5200 MHz; Duty Cycle: 1:1

Medium: 5 GHz Body Medium parameters used:

$f = 5200 \text{ MHz}$; $\sigma = 5.071 \text{ mho/m}$; $\epsilon_r = 49.94$; $\rho = 1000 \text{ kg/m}^3$

Phantom section: Flat Section; Space: 1.0 cm

Test Date: 07-05-2012; Ambient Temp: 24.7°C; Tissue Temp: 23.6°C

Probe: EX3DV4 - SN3589; ConvF(3.92, 3.92, 3.92); Calibrated: 1/27/2012;

Sensor-Surface: 2mm (Mechanical Surface Detection)

Electronics: DAE4 Sn1323; Calibrated: 2/15/2012

Phantom: SAM Main; Type: SAM 4.0; Serial: TP-1114

Measurement SW: DASY4, Version 4.7 (80); SEMCAD X Version 14.6.5 (6469)

5200MHz System Verification

Area Scan (7x9x1): Measurement grid: dx=10mm, dy=10mm

Zoom Scan (7x7x11)/Cube 0: Measurement grid: dx=4mm, dy=4mm, dz=2mm

Input Power = 12.3 dBm (17 mW)

Peak SAR (extrapolated) = 4.744 mW/g

SAR(1 g) = 1.26 mW/g; SAR(10 g) = 0.340 mW/g

Deviation = 0.98%

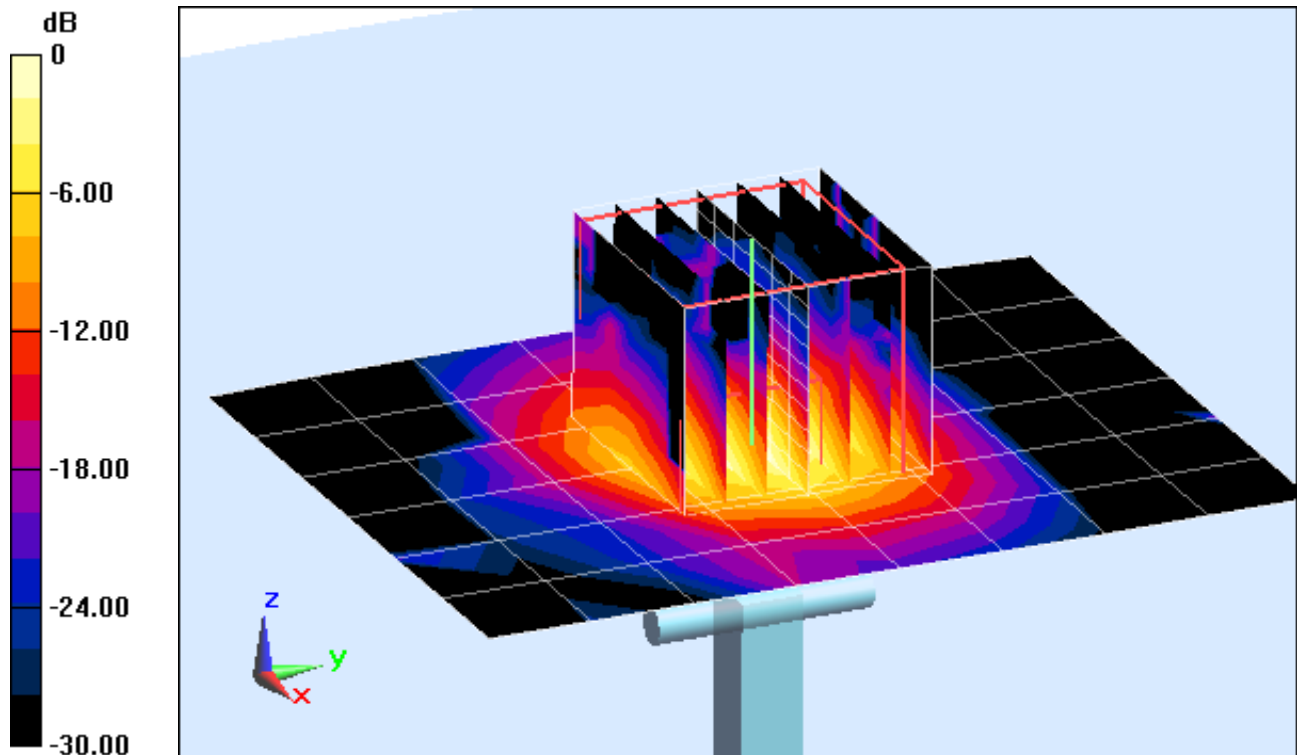

0 dB = 2.60 mW/g = 8.30 dB mW/g

PCTEST ENGINEERING LABORATORY, INC.

DUT: Dipole 5200 MHz; Type: D5GHzV2; Serial: 1057

Communication System: CW; Frequency: 5200 MHz; Duty Cycle: 1:1

Medium: 5 GHz Body Medium parameters used:

$f = 5200 \text{ MHz}$; $\sigma = 5.071 \text{ mho/m}$; $\epsilon_r = 49.94$; $\rho = 1000 \text{ kg/m}^3$

Phantom section: Flat Section; Space: 1.0 cm

Test Date: 07-05-2012; Ambient Temp: 24.7°C; Tissue Temp: 23.6°C

Probe: EX3DV4 - SN3589; ConvF(3.92, 3.92, 3.92); Calibrated: 1/27/2012;

Sensor-Surface: 2mm (Mechanical Surface Detection)

Electronics: DAE4 Sn1323; Calibrated: 2/15/2012

Phantom: SAM Main; Type: SAM 4.0; Serial: TP-1114

Measurement SW: DASY4, Version 4.7 (80); SEMCAD X Version 14.6.5 (6469)

5200MHz System Verification

Area Scan (7x9x1): Measurement grid: dx=10mm, dy=10mm

Zoom Scan (7x7x11)/Cube 0: Measurement grid: dx=4mm, dy=4mm, dz=2mm

Input Power = 12.3 dBm (17 mW)

Peak SAR (extrapolated) = 4.744 mW/g

SAR(1 g) = 1.26 mW/g; SAR(10 g) = 0.340 mW/g

Deviation = 0.98%

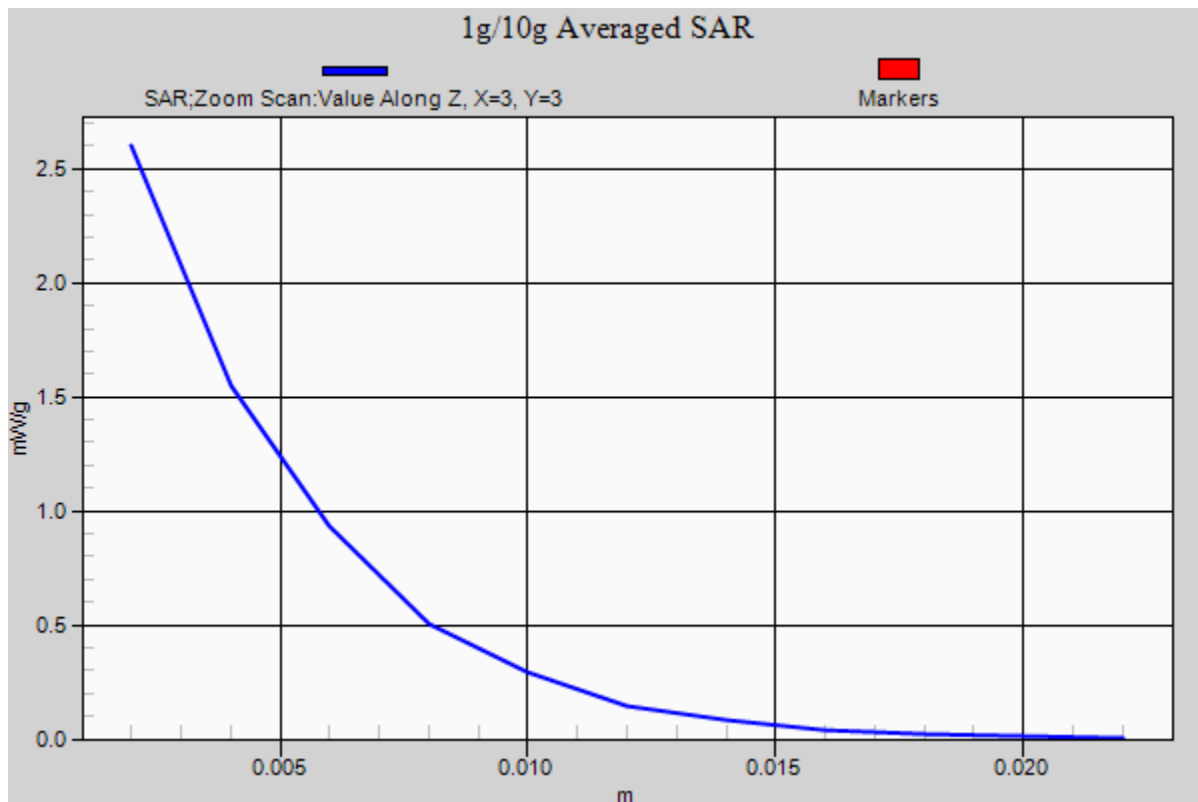

PCTEST ENGINEERING LABORATORY, INC.

DUT: Dipole 5500 MHz; Type: D5GHzV2; Serial: 1057

Communication System: CW; Frequency: 5500 MHz; Duty Cycle: 1:1

Medium: 5 GHz Body Medium parameters used:

$f = 5500 \text{ MHz}$; $\sigma = 5.498 \text{ mho/m}$; $\epsilon_r = 49.29$; $\rho = 1000 \text{ kg/m}^3$

Phantom section: Flat Section; Space: 1.0 cm

Test Date: 07-05-2012; Ambient Temp: 24.7°C; Tissue Temp: 23.6°C

Probe: EX3DV4 - SN3589; ConvF(3.4, 3.4, 3.4); Calibrated: 1/27/2012;

Sensor-Surface: 2mm (Mechanical Surface Detection)

Electronics: DAE4 Sn1323; Calibrated: 2/15/2012

Phantom: SAM Main; Type: SAM 4.0; Serial: TP-1114

Measurement SW: DASY4, Version 4.7 (80); SEMCAD X Version 14.6.5 (6469)

5500MHz System Verification

Area Scan (7x9x1): Measurement grid: dx=10mm, dy=10mm

Zoom Scan (7x7x11)/Cube 0: Measurement grid: dx=4mm, dy=4mm, dz=2mm

Input Power = 12.3 dBm (17 mW)

Peak SAR (extrapolated) = 5.386 mW/g

SAR(1 g) = 1.34 mW/g; SAR(10 g) = 0.349 mW/g

Deviation = -0.10%

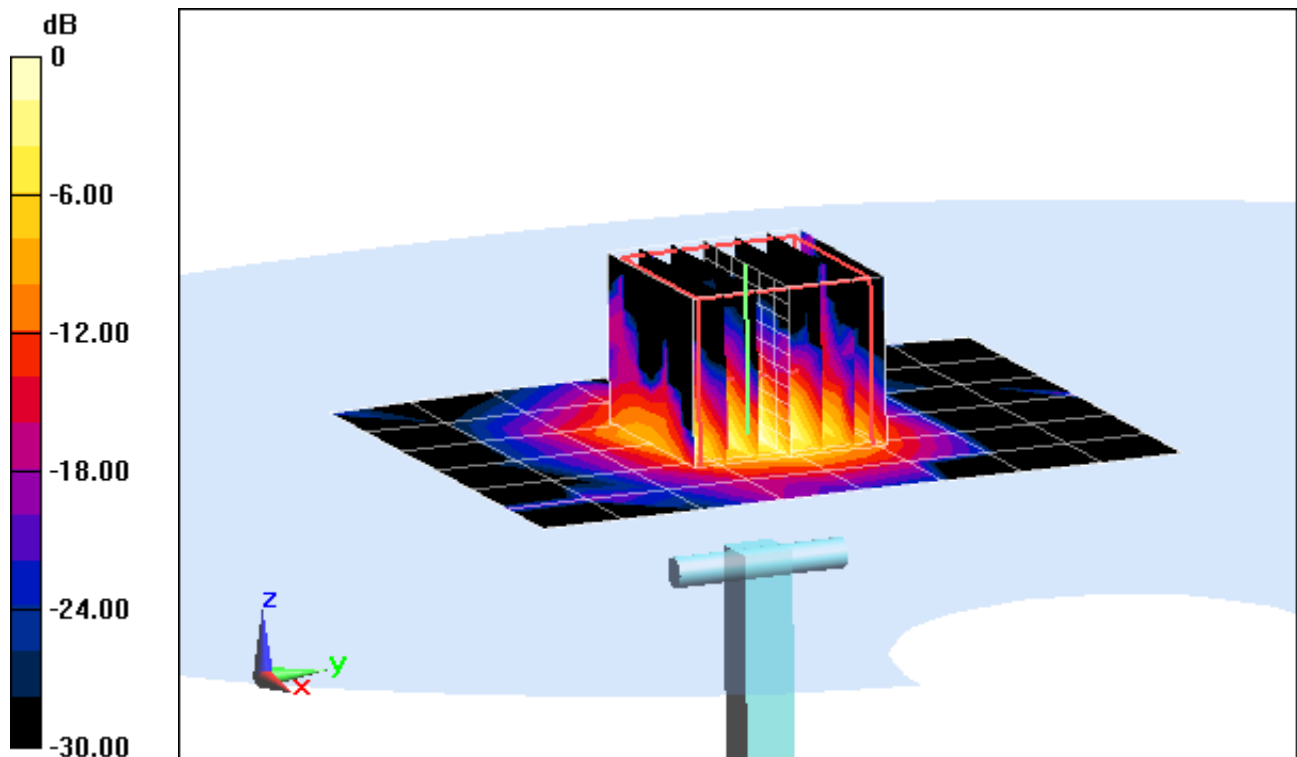

0 dB = 2.87 mW/g = 9.16 dB mW/g

PCTEST ENGINEERING LABORATORY, INC.

DUT: Dipole 5500 MHz; Type: D5GHzV2; Serial: 1057

Communication System: CW; Frequency: 5500 MHz; Duty Cycle: 1:1

Medium: 5 GHz Body Medium parameters used:

$f = 5500 \text{ MHz}$; $\sigma = 5.498 \text{ mho/m}$; $\epsilon_r = 49.29$; $\rho = 1000 \text{ kg/m}^3$

Phantom section: Flat Section; Space: 1.0 cm

Test Date: 07-05-2012; Ambient Temp: 24.7°C; Tissue Temp: 23.6°C

Probe: EX3DV4 - SN3589; ConvF(3.4, 3.4, 3.4); Calibrated: 1/27/2012;

Sensor-Surface: 2mm (Mechanical Surface Detection)

Electronics: DAE4 Sn1323; Calibrated: 2/15/2012

Phantom: SAM Main; Type: SAM 4.0; Serial: TP-1114

Measurement SW: DASY4, Version 4.7 (80); SEMCAD X Version 14.6.5 (6469)

5500MHz System Verification

Area Scan (7x9x1): Measurement grid: dx=10mm, dy=10mm

Zoom Scan (7x7x11)/Cube 0: Measurement grid: dx=4mm, dy=4mm, dz=2mm

Input Power = 12.3 dBm (17 mW)

Peak SAR (extrapolated) = 5.386 mW/g

SAR(1 g) = 1.34 mW/g; SAR(10 g) = 0.349 mW/g

Deviation = -0.10%

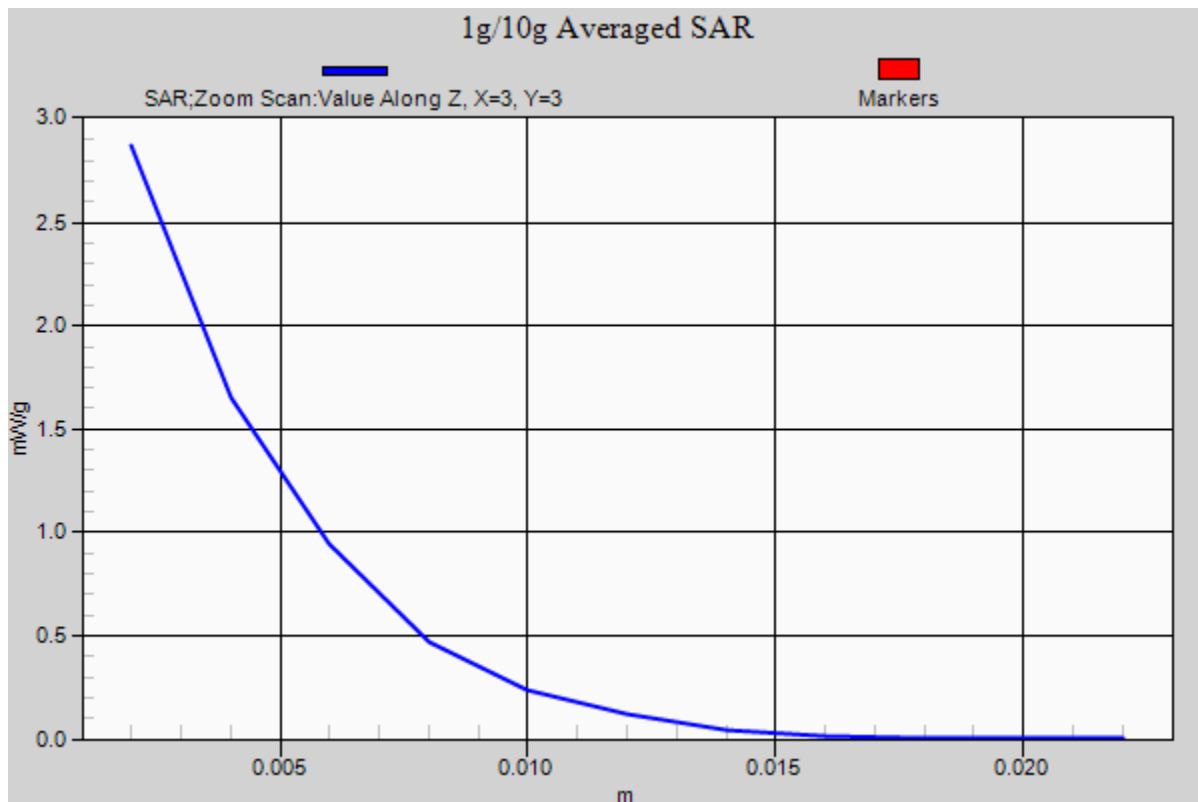

PCTEST ENGINEERING LABORATORY, INC.

DUT: Dipole 5800 MHz; Type: D5GHzV2; Serial: 1057

Communication System: CW; Frequency: 5800 MHz; Duty Cycle: 1:1

Medium: 5 GHz Body Medium parameters used:

$f = 5800 \text{ MHz}$; $\sigma = 5.909 \text{ mho/m}$; $\epsilon_r = 48.85$; $\rho = 1000 \text{ kg/m}^3$

Phantom section: Flat Section; Space; 1.0 cm

Test Date: 07-05-2012; Ambient Temp: 24.9°C; Tissue Temp: 23.8°C

Probe: EX3DV4 - SN3589; ConvF(3.59, 3.59, 3.59); Calibrated: 1/27/2012;

Sensor-Surface: 2mm (Mechanical Surface Detection)

Electronics: DAE4 Sn1323; Calibrated: 2/15/2012

Phantom: SAM Main; Type: SAM 4.0; Serial: TP-1114

Measurement SW: DASY4, Version 4.7 (80); SEMCAD X Version 14.6.5 (6469)

5800MHz System Verification

Area Scan (7x9x1): Measurement grid: dx=10mm, dy=10mm

Zoom Scan (7x7x11)/Cube 0: Measurement grid: dx=4mm, dy=4mm, dz=2mm

Input Power = 12.3 dBm (17 mW)

Peak SAR (extrapolated) = 5.796 mW/g

SAR(1 g) = 1.31 mW/g; SAR(10 g) = 0.336 mW/g

Deviation = 3.71%

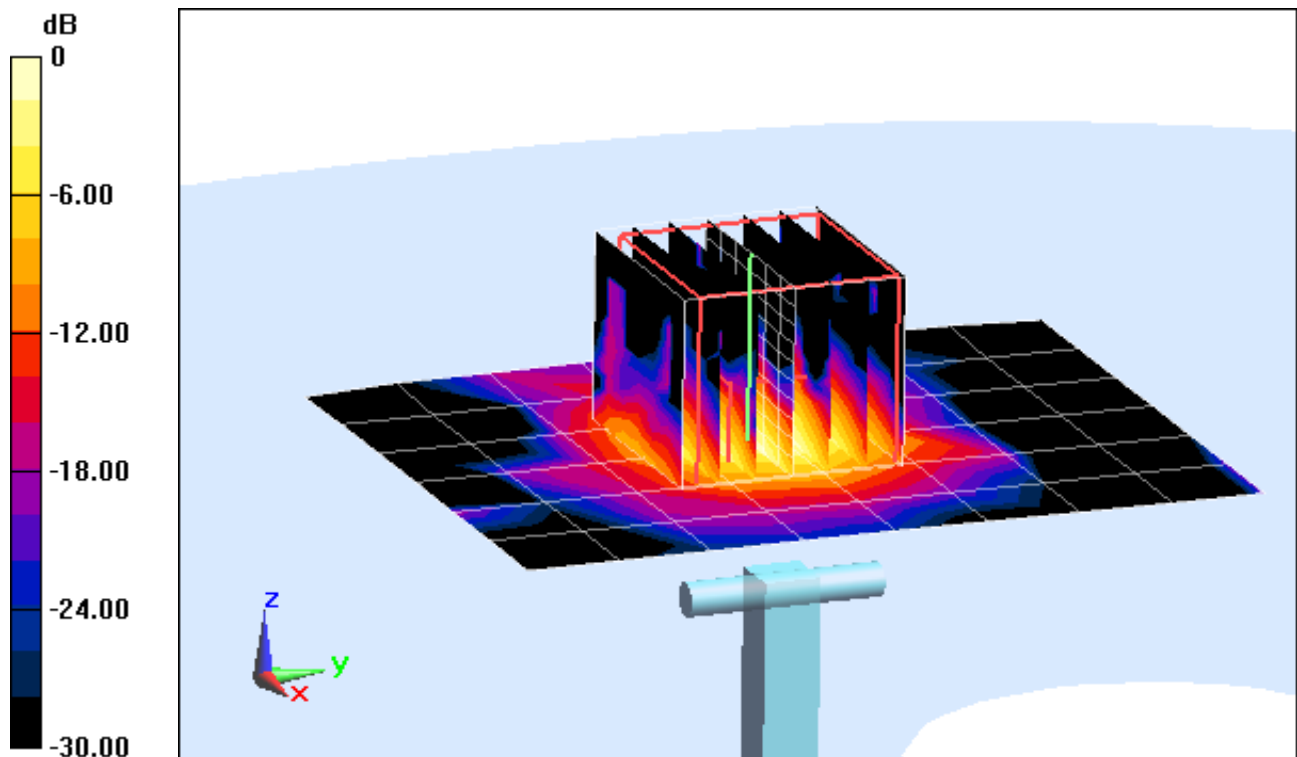

0 dB = 2.78 mW/g = 8.88 dB mW/g

PCTEST ENGINEERING LABORATORY, INC.

DUT: Dipole 5800 MHz; Type: D5GHzV2; Serial: 1057

Communication System: CW; Frequency: 5800 MHz; Duty Cycle: 1:1

Medium: 5 GHz Body Medium parameters used:

$f = 5800 \text{ MHz}$; $\sigma = 5.909 \text{ mho/m}$; $\epsilon_r = 48.85$; $\rho = 1000 \text{ kg/m}^3$

Phantom section: Flat Section; Space; 1.0 cm

Test Date: 07-05-2012; Ambient Temp: 24.9°C; Tissue Temp: 23.8°C

Probe: EX3DV4 - SN3589; ConvF(3.59, 3.59, 3.59); Calibrated: 1/27/2012;

Sensor-Surface: 2mm (Mechanical Surface Detection)

Electronics: DAE4 Sn1323; Calibrated: 2/15/2012

Phantom: SAM Main; Type: SAM 4.0; Serial: TP-1114

Measurement SW: DASY4, Version 4.7 (80); SEMCAD X Version 14.6.5 (6469)

5800MHz System Verification

Area Scan (7x9x1): Measurement grid: dx=10mm, dy=10mm

Zoom Scan (7x7x11)/Cube 0: Measurement grid: dx=4mm, dy=4mm, dz=2mm

Input Power = 12.3 dBm (17 mW)

Peak SAR (extrapolated) = 5.796 mW/g

SAR(1 g) = 1.31 mW/g; SAR(10 g) = 0.336 mW/g

Deviation = 3.71%

