



**FCC CFR47 PART 15 SUBPART C**

**CERTIFICATION TEST REPORT**

**FOR**

**CELLULAR/PCS GSM/GPRS/EDGE AND AWS WCDMA/HSPA PHONE WITH  
BLUETOOTH AND WLAN**

**MODEL NUMBERS: E739, LG-E739\***

**FCC ID: ZNFE739**

**REPORT NUMBER: 11U13937-1**

**ISSUE DATE: AUGUST 01, 2011**

*Prepared for*  
**LG ELECTRONICS MOBILECOMM U.S.A., INC.**  
**10101 OLD GROVE ROAD**  
**SAN DIEGO, CA 92131**

*Prepared by*  
**COMPLIANCE CERTIFICATION SERVICES (UL CCS)**  
**47173 BENICIA STREET**  
**FREMONT, CA 94538, U.S.A.**  
**TEL: (510) 771-1000**  
**FAX: (510) 661-0888**

\*The two models covered by this report are identical



NVLAP LAB CODE 200065-0

Revision History

<u>Rev.</u>	<u>Issue Date</u>	<u>Revisions</u>	<u>Revised By</u>
--	08/01/11	Initial Issue	F. Ibrahim

**TABLE OF CONTENTS**

**1. ATTESTATION OF TEST RESULTS.....5**

**2. TEST METHODOLOGY .....6**

**3. FACILITIES AND ACCREDITATION.....6**

**4. CALIBRATION AND UNCERTAINTY .....6**

    4.1. *MEASURING INSTRUMENT CALIBRATION* .....6

    4.2. *SAMPLE CALCULATION*.....6

    4.3. *MEASUREMENT UNCERTAINTY* .....6

**5. EQUIPMENT UNDER TEST .....7**

    5.1. *DESCRIPTION OF EUT*.....7

    5.2. *MAXIMUM OUTPUT POWER*.....7

    5.3. *DESCRIPTION OF AVAILABLE ANTENNAS*.....7

    5.4. *SOFTWARE AND FIRMWARE*.....7

    5.5. *WORST-CASE CONFIGURATION AND MODE*.....8

    5.6. *DESCRIPTION OF TEST SETUP*.....9

**6. TEST AND MEASUREMENT EQUIPMENT .....11**

**ANTENNA PORT TEST RESULTS .....12**

    6.1. *802.11b MODE IN THE 2.4 GHz BAND*.....12

        6.1.1. 6 dB BANDWIDTH .....12

        6.1.2. OUTPUT POWER .....15

        6.1.3. AVERAGE POWER .....18

        6.1.4. POWER SPECTRAL DENSITY .....19

        6.1.5. CONDUCTED SPURIOUS EMISSIONS.....22

    6.2. *802.11g MODE IN THE 2.4 GHz BAND*.....26

        6.2.1. 6 dB BANDWIDTH .....26

        6.2.2. OUTPUT POWER .....29

        6.2.3. AVERAGE POWER .....32

        6.2.4. POWER SPECTRAL DENSITY .....33

        6.2.5. CONDUCTED SPURIOUS EMISSIONS.....36

    6.3. *802.11n HT20 MODE IN THE 2.4 GHz BAND*.....40

        6.3.1. 6 dB BANDWIDTH .....40

        6.3.2. OUTPUT POWER .....43

        6.3.3. AVERAGE POWER .....46

        6.3.4. POWER SPECTRAL DENSITY .....47

        6.3.5. CONDUCTED SPURIOUS EMISSIONS.....50

**7. RADIATED TEST RESULTS .....54**

    7.1. *LIMITS AND PROCEDURE* .....54

---

7.2.	TRANSMITTER ABOVE 1 GHz .....	55
7.2.1.	802.11b MODE IN THE 2.4 GHz BAND.....	55
7.2.2.	802.11g MODE IN THE 2.4 GHz BAND.....	60
7.2.3.	802.11n HT20 SISO MODE IN THE 2.4 GHz BAND .....	65
7.1.	WORST-CASE BELOW 1 GHz.....	70
8.	AC POWER LINE CONDUCTED EMISSIONS.....	73
9.	MAXIMUM PERMISSIBLE EXPOSURE.....	77
10.	SETUP PHOTOS.....	81

# 1. ATTESTATION OF TEST RESULTS

**COMPANY NAME:** LG ELECTRONICS MOBILECOMM U.S.A., INC.  
 10101 OLD GROVE ROAD  
 SAN DIEGO, CA 92131

**EUT DESCRIPTION:** Cellular/PCS GSM/GPRS/EDGE and AWS WCDMA/HSPA Phone with Bluetooth and WLAN

**MODELS:** E739, LG-E739

**SERIAL NUMBER:** 106KPPB038184 for conducted sample &  
 106KPDT033074 for radiated sample

**DATE TESTED:** JULY 19 to 21, 2011

APPLICABLE STANDARDS	
STANDARD	TEST RESULTS
CFR 47 Part 15 Subpart C	Pass

Compliance Certification Services (UL CCS) tested the above equipment in accordance with the requirements set forth in the above standards. All indications of Pass/Fail in this report are opinions expressed by UL CCS based on interpretations and/or observations of test results. Measurement Uncertainties were not taken into account and are published for informational purposes only. The test results show that the equipment tested is capable of demonstrating compliance with the requirements as documented in this report.

**Note:** The results documented in this report apply only to the tested sample, under the conditions and modes of operation as described herein. This document may not be altered or revised in any way unless done so by UL CCS and all revisions are duly noted in the revisions section. Any alteration of this document not carried out by UL CCS will constitute fraud and shall nullify the document. This report must not be used by the client to claim product certification, approval, or endorsement by NVLAP, NIST, any agency of the Federal Government, or any agency of any government.

Approved & Released For UL CCS By:

Tested By:



FRANK IBRAHIM  
 EMC SUPERVISOR  
 UL CCS

VIEN TRAN  
 EMC ENGINEER  
 UL CCS

## 2. TEST METHODOLOGY

The tests documented in this report were performed in accordance with ANSI C63.10-2009, FCC CFR 47 Part 2, and FCC CFR 47 Part 15.

## 3. FACILITIES AND ACCREDITATION

The test sites and measurement facilities used to collect data are located at 47173 Benicia Street, Fremont, California, USA.

UL CCS is accredited by NVLAP, Laboratory Code 200065-0. The full scope of accreditation can be viewed at <http://www.ccsemc.com>.

## 4. CALIBRATION AND UNCERTAINTY

### 4.1. MEASURING INSTRUMENT CALIBRATION

The measuring equipment utilized to perform the tests documented in this report has been calibrated in accordance with the manufacturer's recommendations, and is traceable to recognized national standards.

### 4.2. SAMPLE CALCULATION

Where relevant, the following sample calculation is provided:

$$\begin{aligned} \text{Field Strength (dBuV/m)} &= \text{Measured Voltage (dBuV)} + \text{Antenna Factor (dB/m)} + \\ &\text{Cable Loss (dB)} - \text{Preamp Gain (dB)} \\ 36.5 \text{ dBuV} + 18.7 \text{ dB/m} + 0.6 \text{ dB} - 26.9 \text{ dB} &= 28.9 \text{ dBuV/m} \end{aligned}$$

### 4.3. MEASUREMENT UNCERTAINTY

Where relevant, the following measurement uncertainty levels have been estimated for tests performed on the apparatus:

PARAMETER	UNCERTAINTY
Conducted Disturbance, 0.15 to 30 MHz	3.52 dB
Radiated Disturbance, 30 to 1000 MHz	4.94 dB

Uncertainty figures are valid for a confidence level of 95%.

## 5. EQUIPMENT UNDER TEST

### 5.1. DESCRIPTION OF EUT

The EUT is a smart-phone that features GSM/EGPRS/EDGE and AWS WCDMA/HSPA with Bluetooth & WLAN

The radio module is manufactured by Broadcom Co.

### 5.2. MAXIMUM OUTPUT POWER

The transmitter has a maximum peak conducted output power as follows:

Frequency Range (MHz)	Mode	Output Power (dBm)	Output Power (mW)
2412-2462	802.11b	17.91	61.80
2412-2462	802.11g	22.09	161.81
2412-2462	802.11n HT20	20.90	123.03

### 5.3. DESCRIPTION OF AVAILABLE ANTENNAS

The radio uses a PIFA (Planar Inverted F Antenna) with a maximum peak gain of -2.19dBi.

### 5.4. SOFTWARE AND FIRMWARE

The EUT software installed during testing was LGE739-V08a-June 11, 2011.

The test utility software used during testing was FTM Test.

---

## 5.5. WORST-CASE CONFIGURATION AND MODE

Radiated emissions below 1 GHz and power line conducted emissions were performed with the EUT set to the channel with highest output power, 802.11g mode channel 11.

The EUT is a portable device that may be used in any orientation. The EUT may or may not be connected to its AC power adapter and earphones during use. The EUT was initially assessed in each of three axes of operation (X, Y and Z) with and without the AC adaptor and earphones connected to determine the worst-case condition. This was found to be with the EUT in the X orientation with its AC power adapter and earphones connected. See the setup photographs for an indication of the EUT orientations.

Worst-case data rates used based on input from the client were as follows:

802.11b mode: 1 Mbps

802.11g mode: 6 Mbps

802.11n mode: MCS0



**5.6. DESCRIPTION OF TEST SETUP****SUPPORT EQUIPMENT**

PERIPHERAL SUPPORT EQUIPMENT LIST				
Description	Manufacturer	Model	Serial Number	FCC ID
AC Adapter	LG Electronics	STA-U13WT	000000000032	N/A
Ear Phone	LG Electronics	N/A	N/A	N/A

**I/O CABLES**

I/O CABLE LIST						
Cable No.	Port	#of Identical Ports	Connector Type	Cable Type	Cable Length	Remarks
1	DC	1	MINI USB	Un-Shielded	1.0m	External ferrite added
2	AUDIO	1	MINI JACK	Un-Shielded	1.0m	Volume control on cable

**TEST SETUP**

The EUT is a stand-alone device and was tested with AC/USB adapter and earphone.

**SETUP DIAGRAM FOR TESTS**

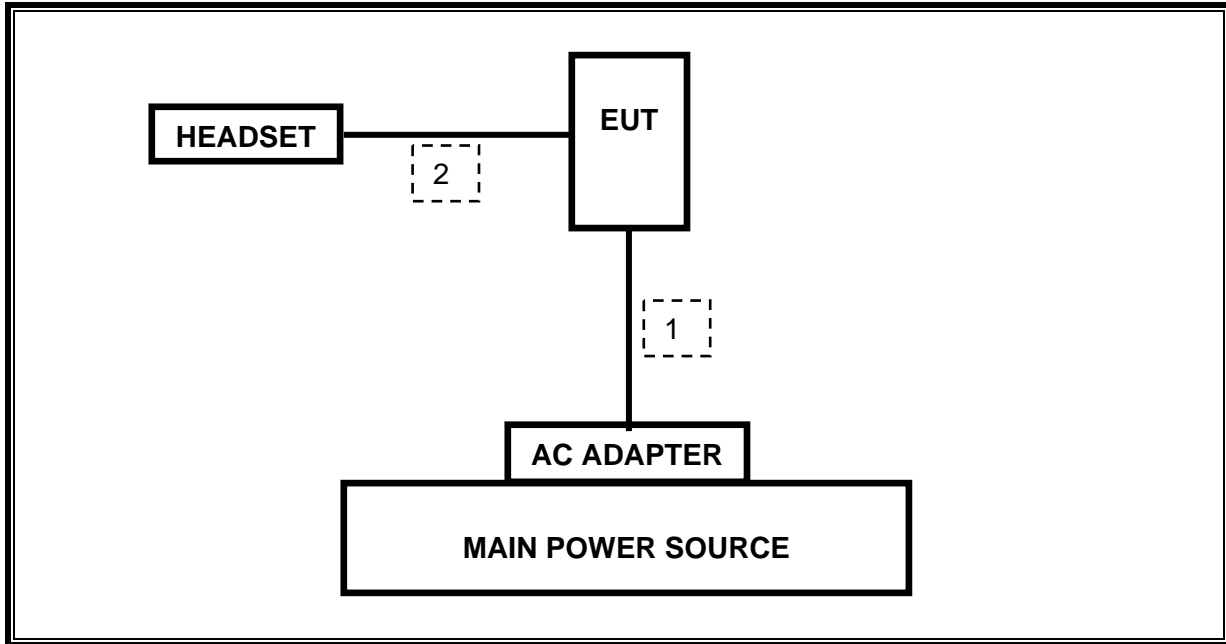

## 6. TEST AND MEASUREMENT EQUIPMENT

The following test and measurement equipment was utilized for the tests documented in this report:

TEST EQUIPMENT LIST				
Description	Manufacturer	Model	Asset	Cal Due
Spectrum Analyzer, 26.5 GHz	Agilent / HP	E4440A	C01178	08/30/11
Preamplifier, 26.5 GHz	Agilent / HP	8449B	C01063	07/08/12
Preamplifier, 1300 MHz	Agilent / HP	8447D	C00558	01/27/12
Antenna, Horn, 18 GHz	EMCO	3115	C00783	06/29/12
Antenna, Horn, 26.5 GHz	ARA	MMH-1826/B	C00980	07/29/11
Antenna, Bilog, 2 GHz	Sunol Sciences	JB1	C01016	07/16/12
Reject Filter, 2.4-2.5 GHz	Micro-Tronics	BRM50702	N02685	CNR
Spectrum Analyzer, 26.5 GHz	Agilent / HP	E4407B	C01098	04/30/12
Power Meter	Agilent / HP	437B	N02778	08/11/12
Power Sensor, 18 GHz	Agilent / HP	8481A	N02784	07/28/11
LISN, 30 MHz	FCC	LISN-50/250-25-2	N02625	11/10/11

## ANTENNA PORT TEST RESULTS

### 6.1. 802.11b MODE IN THE 2.4 GHz BAND

#### 6.1.1. 6 dB BANDWIDTH

##### LIMITS

FCC §15.247 (a) (2)

IC RSS-210 A8.2 (a)

The minimum 6 dB bandwidth shall be at least 500 kHz.

##### TEST PROCEDURE

The transmitter output is connected to a spectrum analyzer. The RBW is set to 100 kHz and the VBW is set to 300 kHz. The sweep time is coupled.

##### RESULTS

Channel	Frequency (MHz)	6 dB Bandwidth (MHz)	Minimum Limit (MHz)
Low	2412	7.08	0.5
Middle	2437	7.08	0.5
High	2462	7.00	0.5

**6 dB BANDWIDTH**

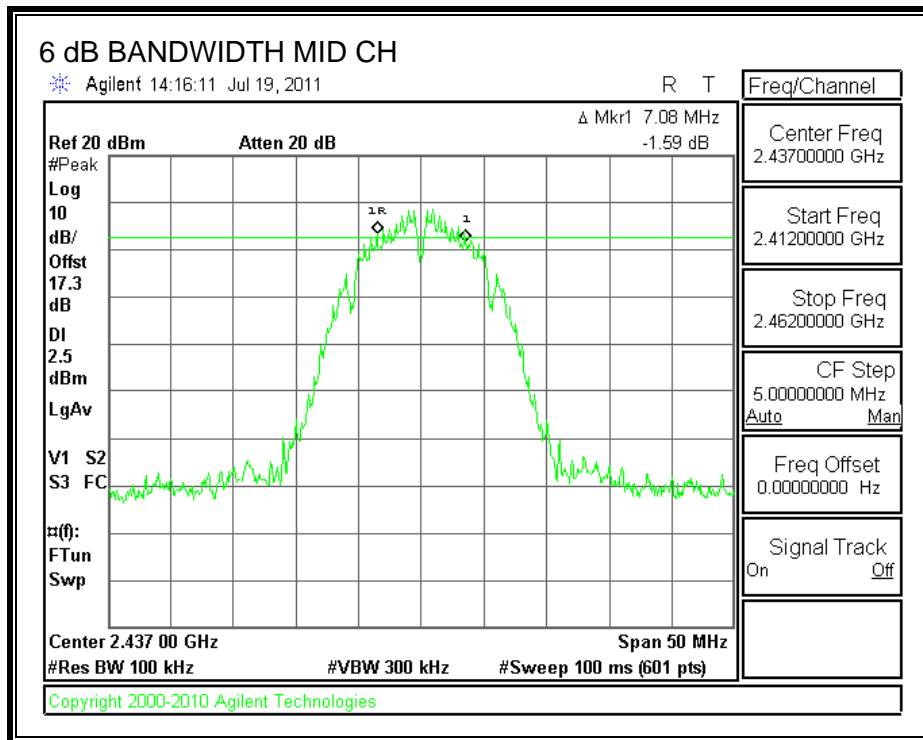
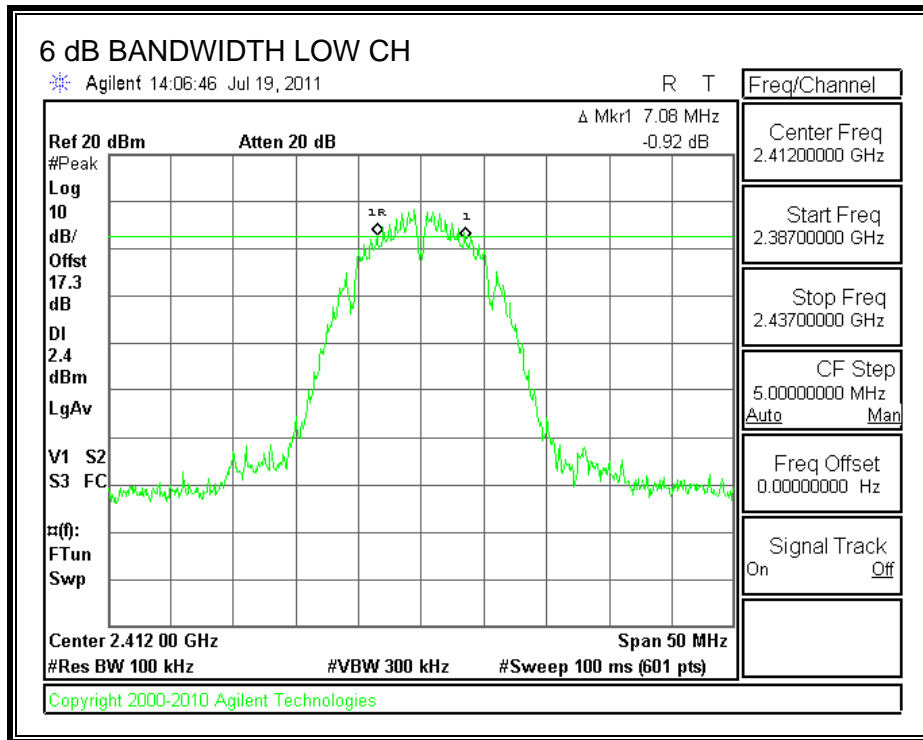

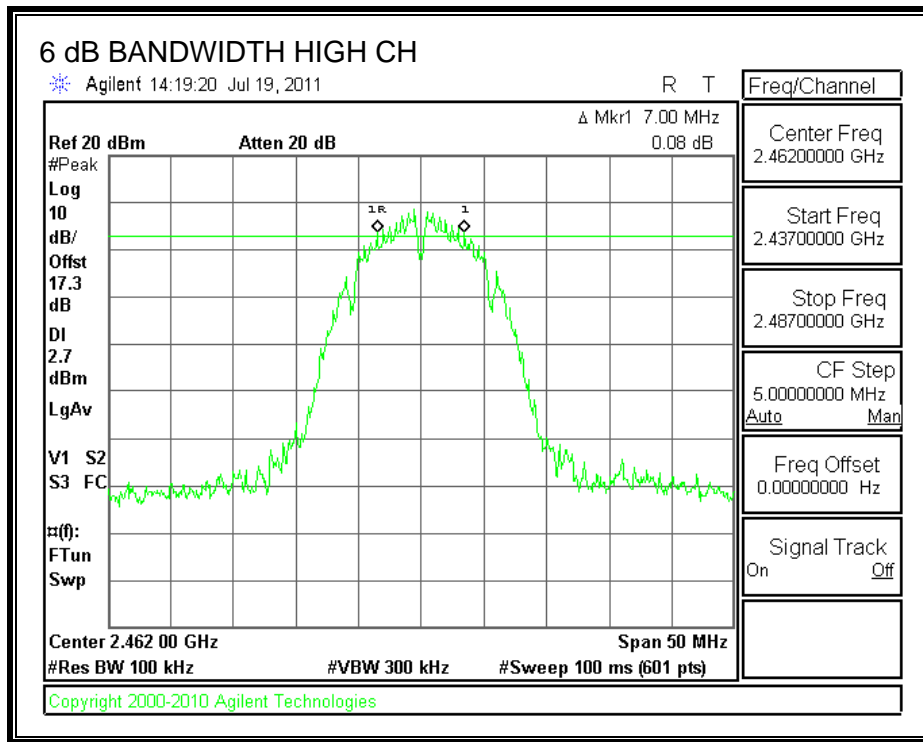

## 6.1.2. OUTPUT POWER

### LIMITS

FCC §15.247 (b)

IC RSS-210 A8.4

The maximum antenna gain is less than or equal to 6 dBi, therefore the limit is 30 dBm.

### TEST PROCEDURE

Peak power is measured using the Channel bandwidth Alternative peak output power procedure specified in "TCB Training for Devices covered under Scopes A1 - A4" by Joe Dichoso, May 2003.

### RESULTS

Channel	Frequency (MHz)	Peak Power Reading (dBm)	Attenuator and Cable Offset (dB)	Output Power (dBm)	Limit (dBm)	Margin (dB)
Low	2412	0.59	17.3	17.89	30	-12.11
Middle	2437	0.61	17.3	17.91	30	-12.09
High	2462	0.50	17.3	17.80	30	-12.20

Attenuator and cable offset data was provided by the client

**OUTPUT POWER**

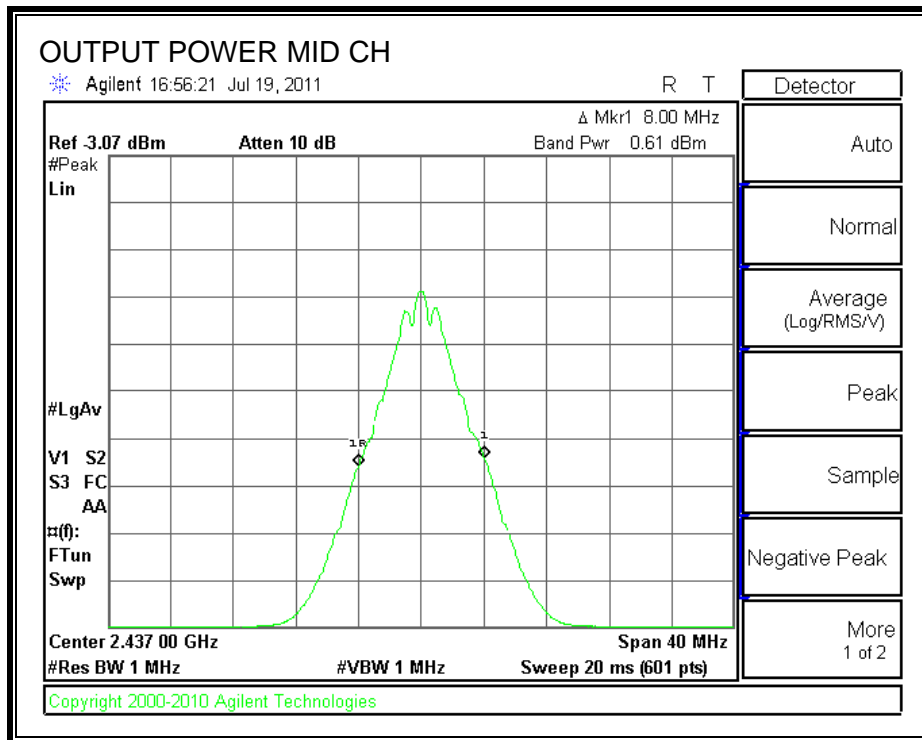
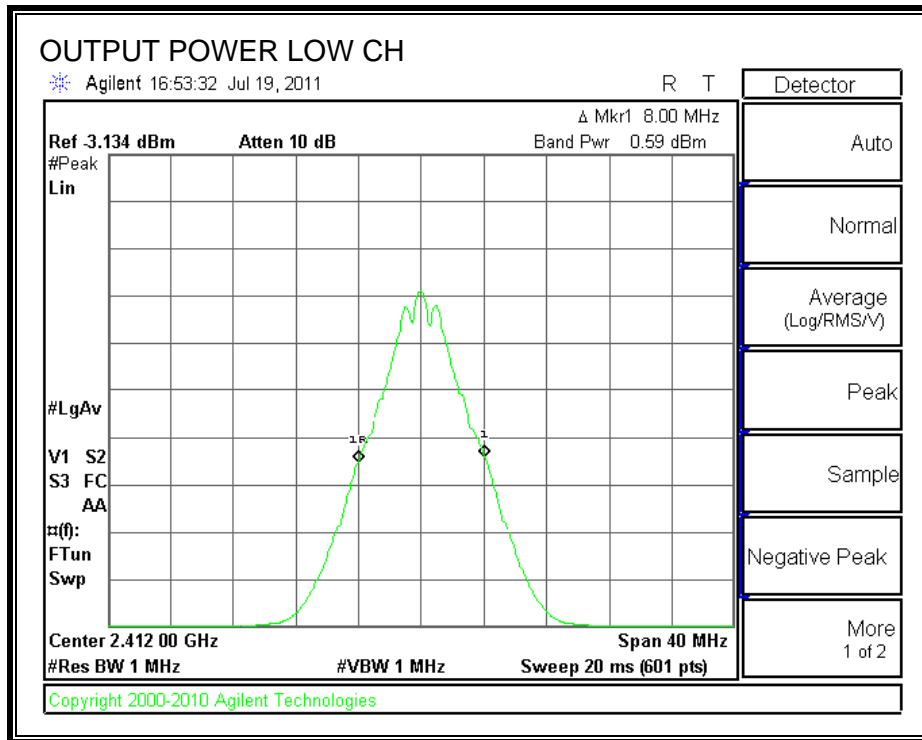



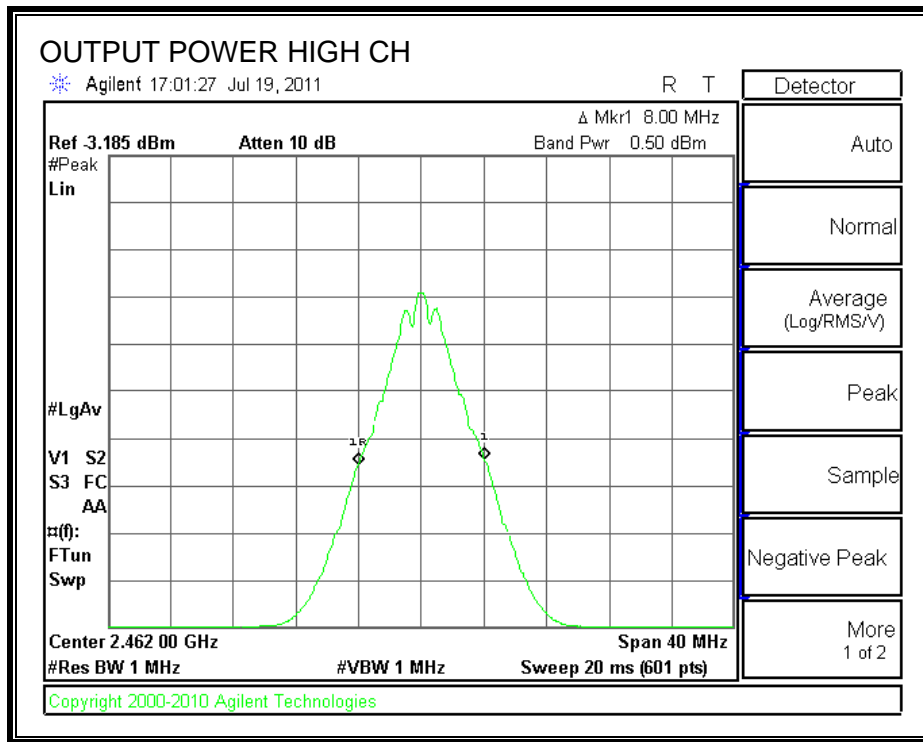

### 6.1.3. AVERAGE POWER

#### LIMITS

None - for reporting purposes only.

#### TEST PROCEDURE

The transmitter output is connected to a power meter.

#### RESULTS

The cable assembly insertion loss of 17.3 dB (including 16.2 dB pad and 1.1 dB cable) was entered as an offset in the power meter to allow for direct reading of power.

Channel	Frequency (MHz)	Power (dBm)
Low	2412	15.50
Middle	2437	15.75
High	2462	15.80

### 6.1.4. POWER SPECTRAL DENSITY

#### LIMITS

FCC §15.247 (e)

IC RSS-210 A8.2 (b)

The power spectral density conducted from the transmitter to the antenna shall not be greater than 8 dBm in any 3 kHz band during any time interval of continuous transmission.

#### TEST PROCEDURE

Output power was measured based on the use of a peak measurement, therefore the power spectral density was measured using PSD Option 1 in accordance with FCC document "Measurement of Digital Transmission Systems Operating under Section 15.247", March 23, 2005.

#### RESULTS

Channel	Frequency (MHz)	PPSD (dBm)	Limit (dBm)	Margin (dB)
Low	2412	-3.80	8	-11.80
Middle	2437	-3.38	8	-11.38
High	2462	-3.69	8	-11.69

**POWER SPECTRAL DENSITY**

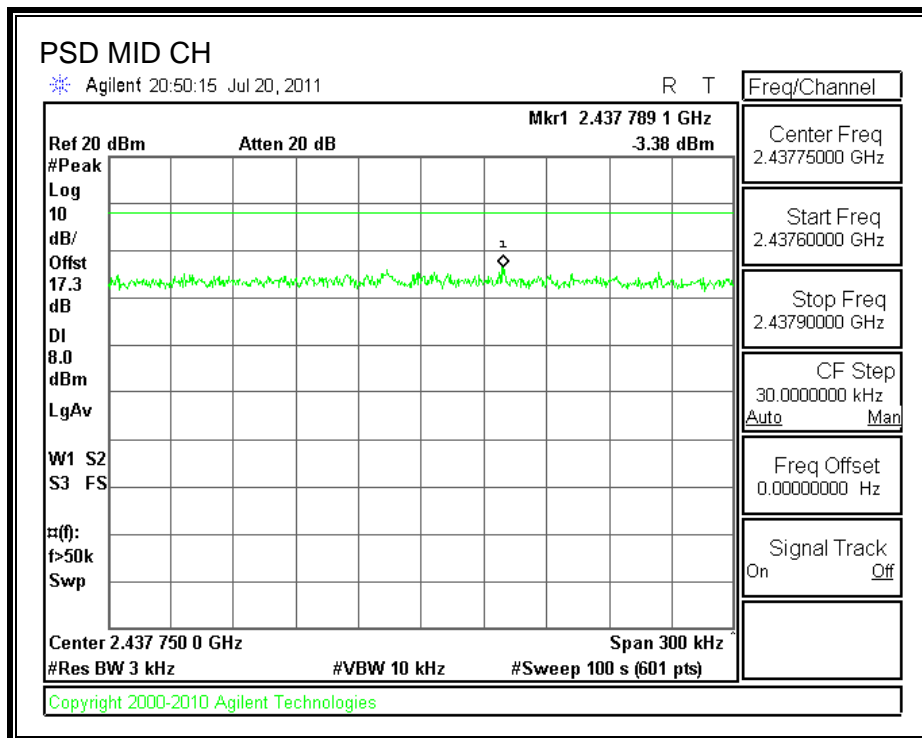
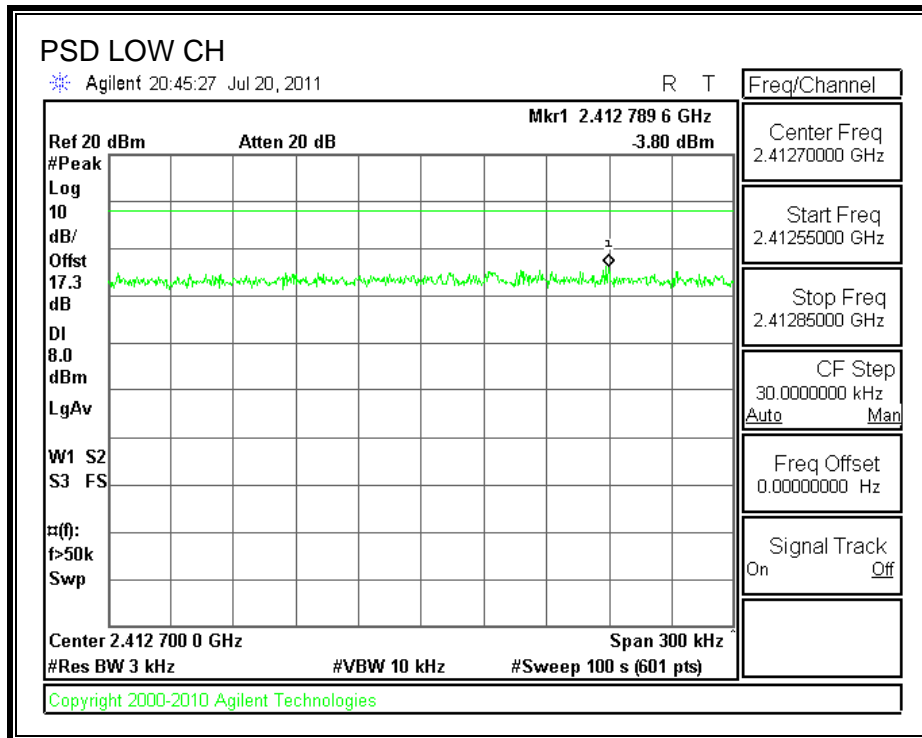

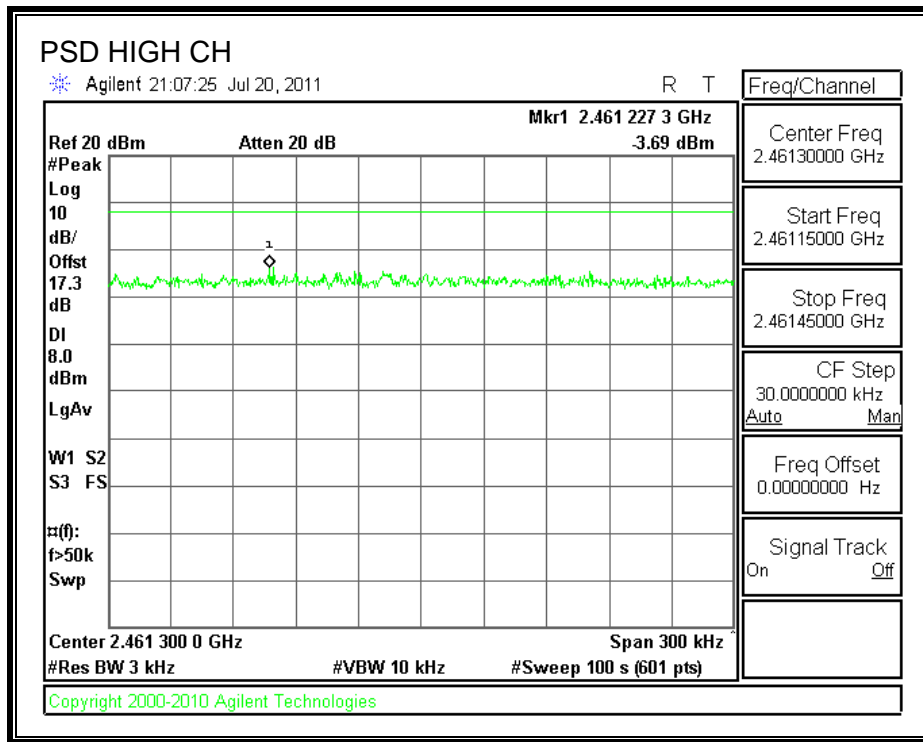

## 6.1.5. CONDUCTED SPURIOUS EMISSIONS

### LIMITS

FCC §15.247 (d)

IC RSS-210 A8.5

Output power was measured based on the use of a peak measurement, therefore the required attenuation is 20 dB.

### TEST PROCEDURE

The transmitter output is connected to a spectrum analyzer. The resolution bandwidth is set to 100 kHz. The video bandwidth is set to 300 kHz.

The spectrum from 30 MHz to 26 GHz is investigated with the transmitter set to the lowest, middle, and highest channels.

**RESULTS**

**SPURIOUS EMISSIONS, LOW CHANNEL**

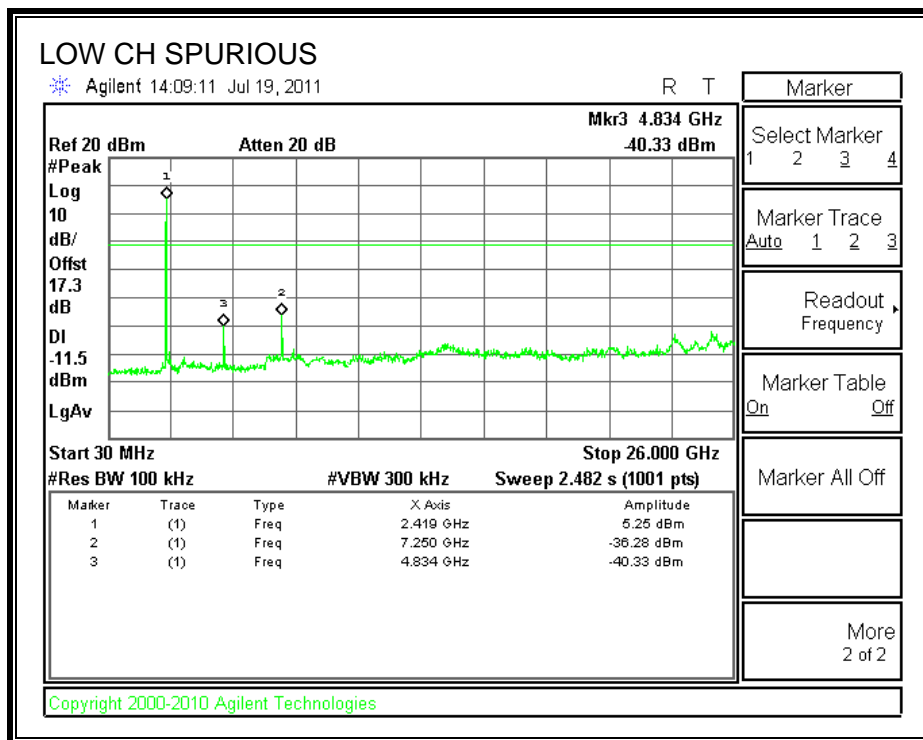
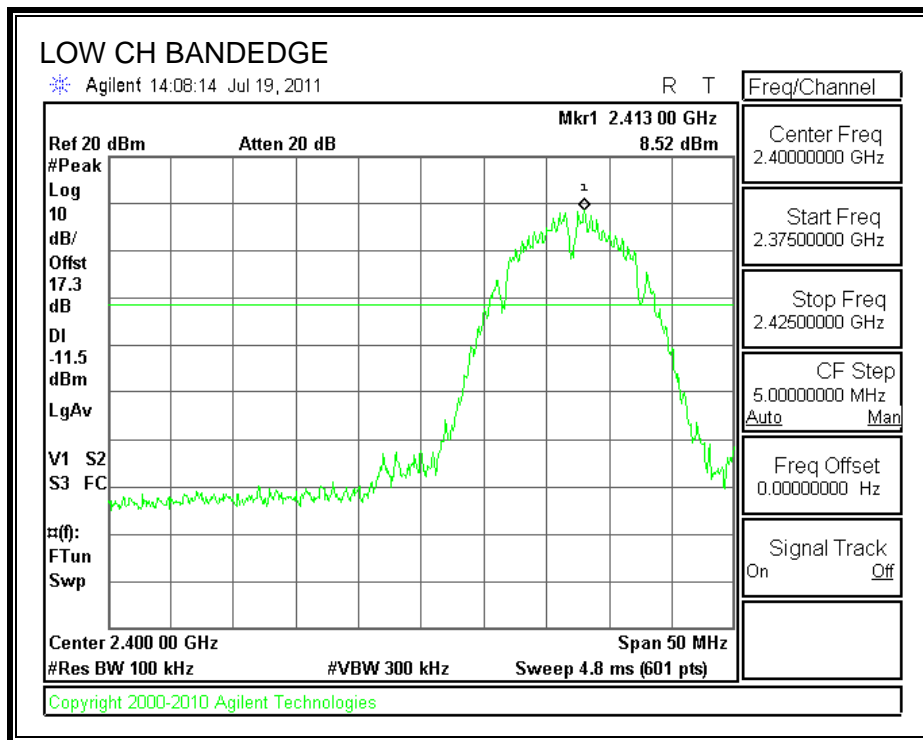

**SPURIOUS EMISSIONS, MID CHANNEL**

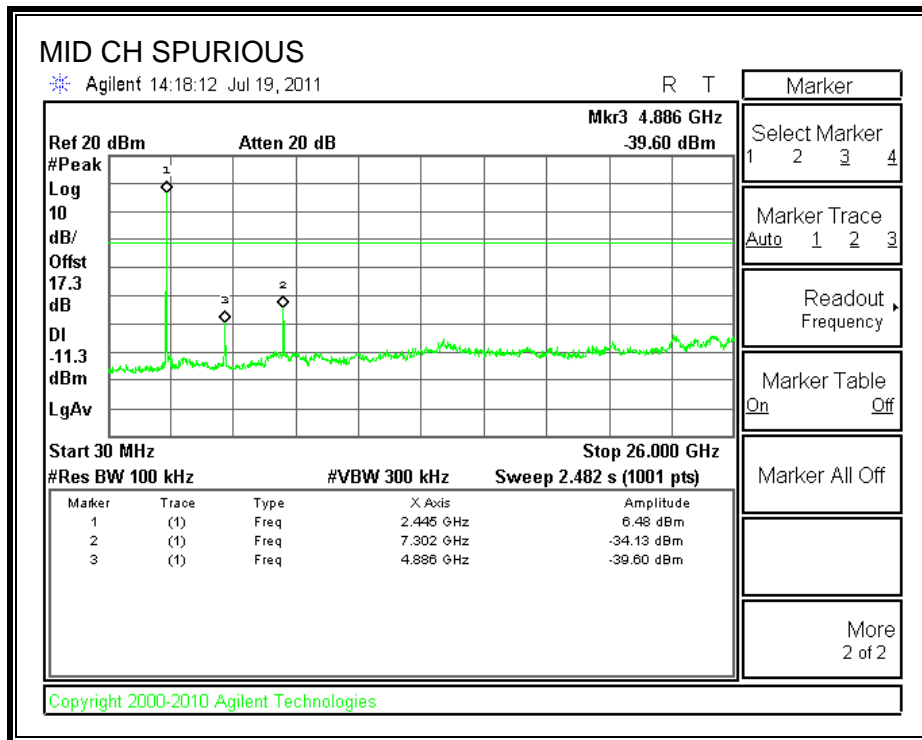
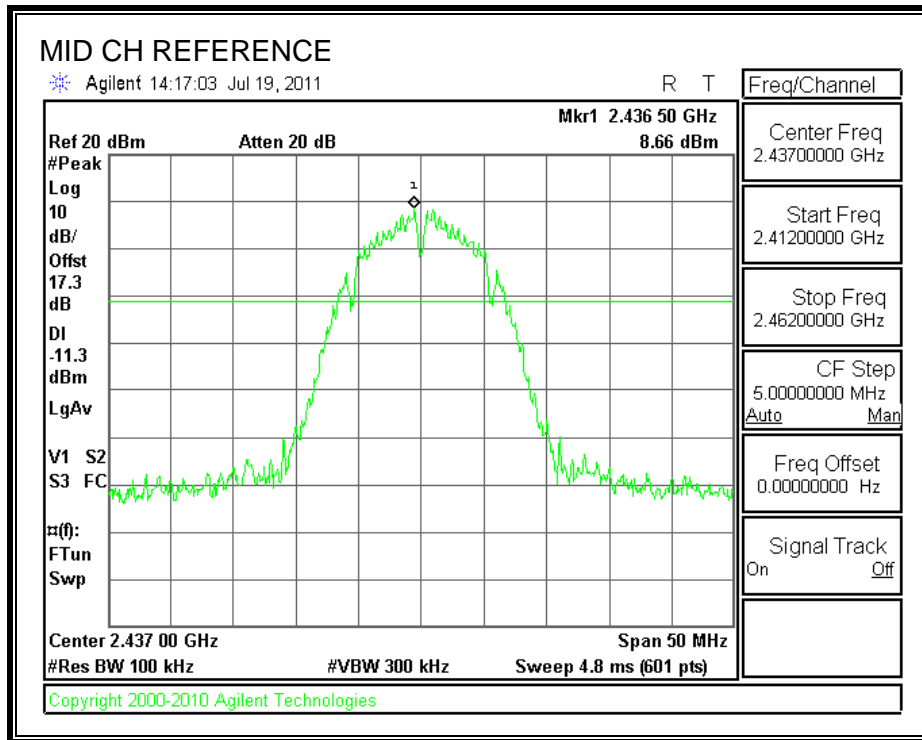



**SPURIOUS EMISSIONS, HIGH CHANNEL**

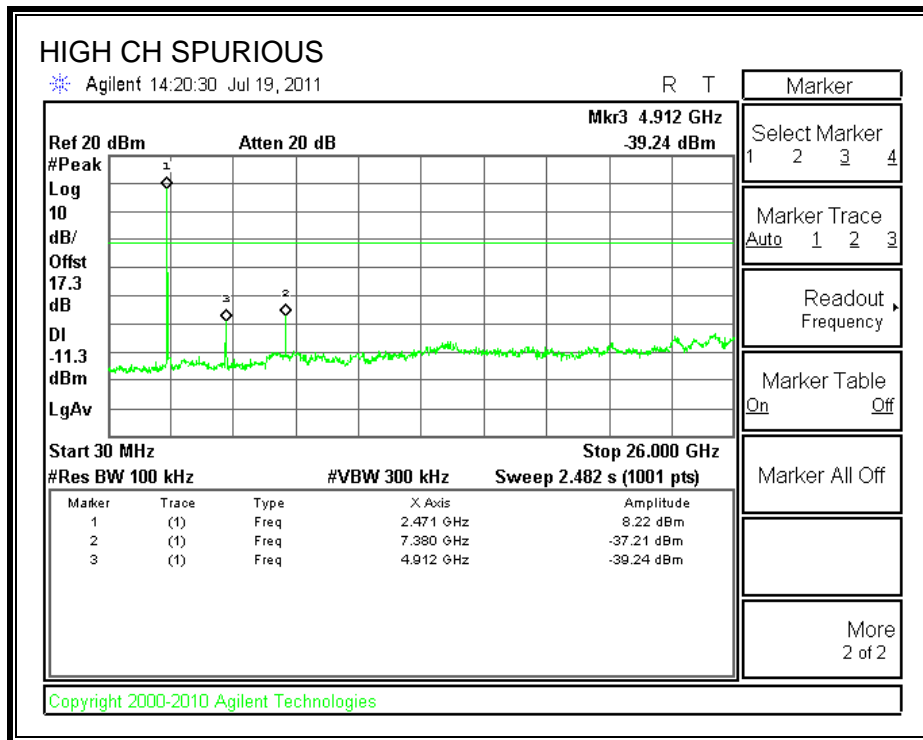
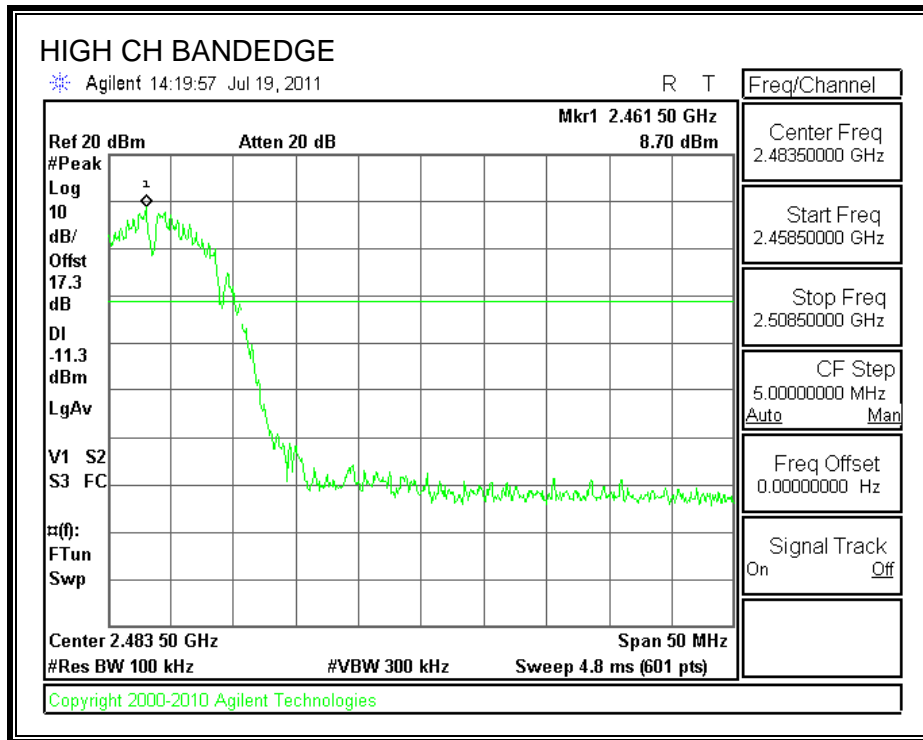

**6.2. 802.11g MODE IN THE 2.4 GHz BAND****6.2.1. 6 dB BANDWIDTH****LIMITS**

FCC §15.247 (a) (2)

IC RSS-210 A8.2 (a)

The minimum 6 dB bandwidth shall be at least 500 kHz.

**TEST PROCEDURE**

The transmitter output is connected to a spectrum analyzer. The RBW is set to 100 kHz and the VBW is set to 300 kHz. The sweep time is coupled.

**RESULTS**

<b>Channel</b>	<b>Frequency (MHz)</b>	<b>6 dB Bandwidth (MHz)</b>	<b>Minimum Limit (MHz)</b>
Low	2412	15.17	0.5
Middle	2437	15.08	0.5
High	2462	15.17	0.5

**6 dB BANDWIDTH**

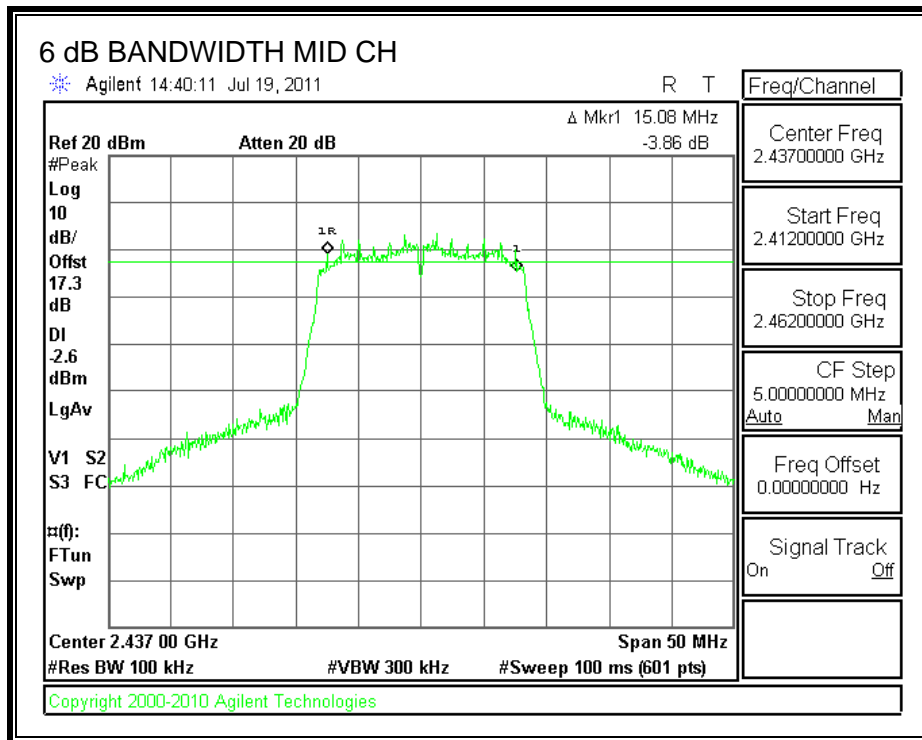
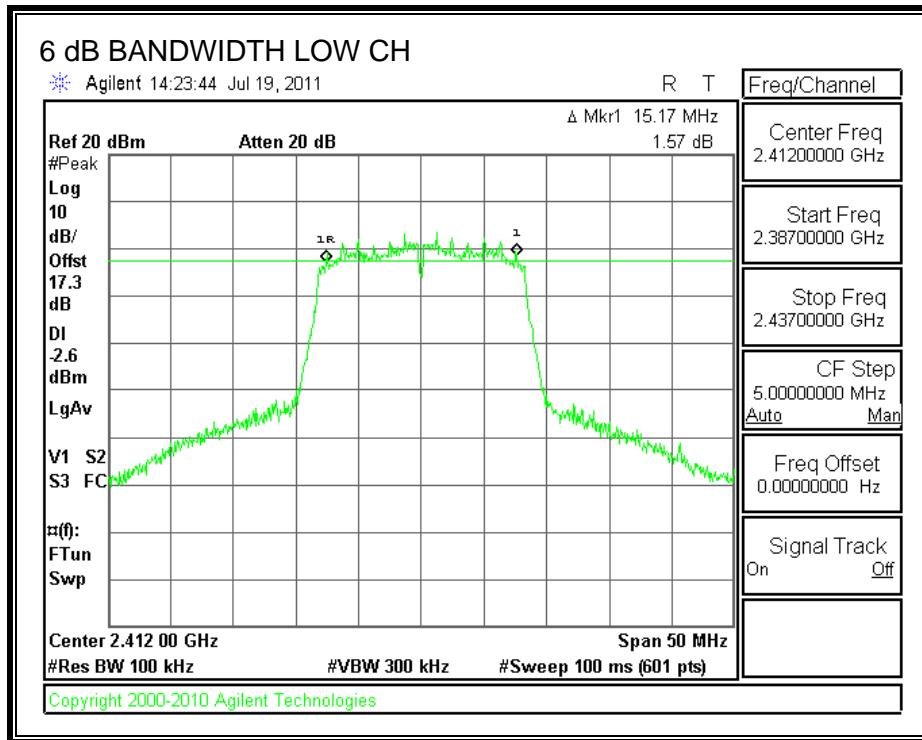

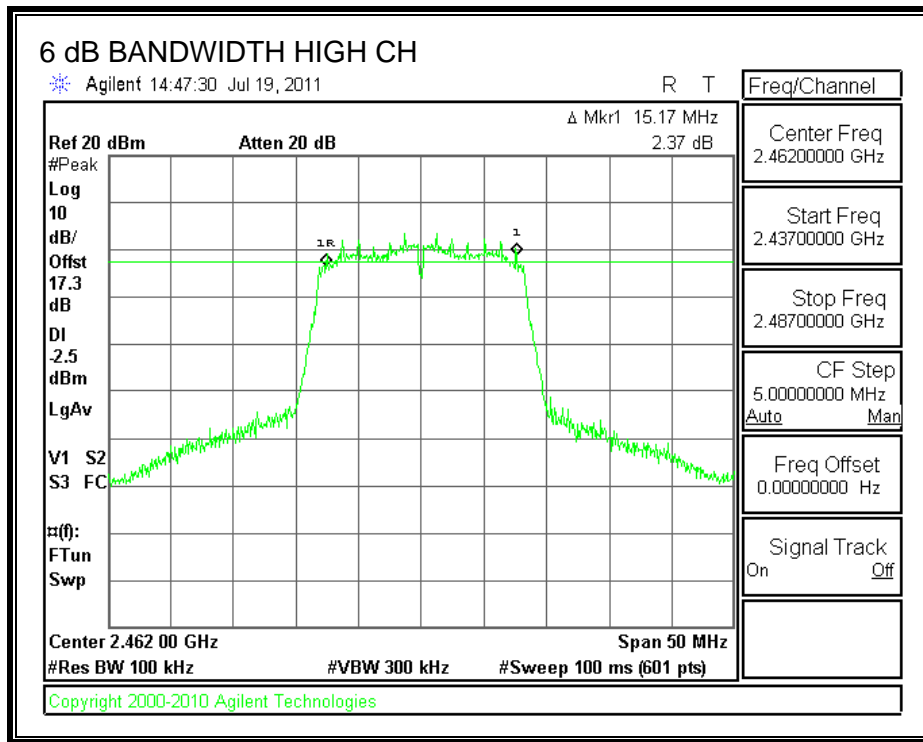

## 6.2.2. OUTPUT POWER

### LIMITS

FCC §15.247 (b)

IC RSS-210 A8.4

The maximum antenna gain is less than or equal to 6 dBi, therefore the limit is 30 dBm.

### TEST PROCEDURE

Peak power is measured using the Channel bandwidth Alternative peak output power procedure specified in "TCB Training for Devices covered under Scopes A1 - A4" by Joe Dichoso, May 2003.

### RESULTS

Channel	Frequency (MHz)	Peak Power Reading (dBm)	Attenuator and Cable Offset (dB)	Output Power (dBm)	Limit (dBm)	Margin (dB)
Low	2412	4.60	17.3	21.90	30	-8.10
Middle	2437	4.73	17.3	22.03	30	-7.97
High	2462	4.79	17.3	22.09	30	-7.91

Attenuator and cable offset data was provided by the client

**OUTPUT POWER**

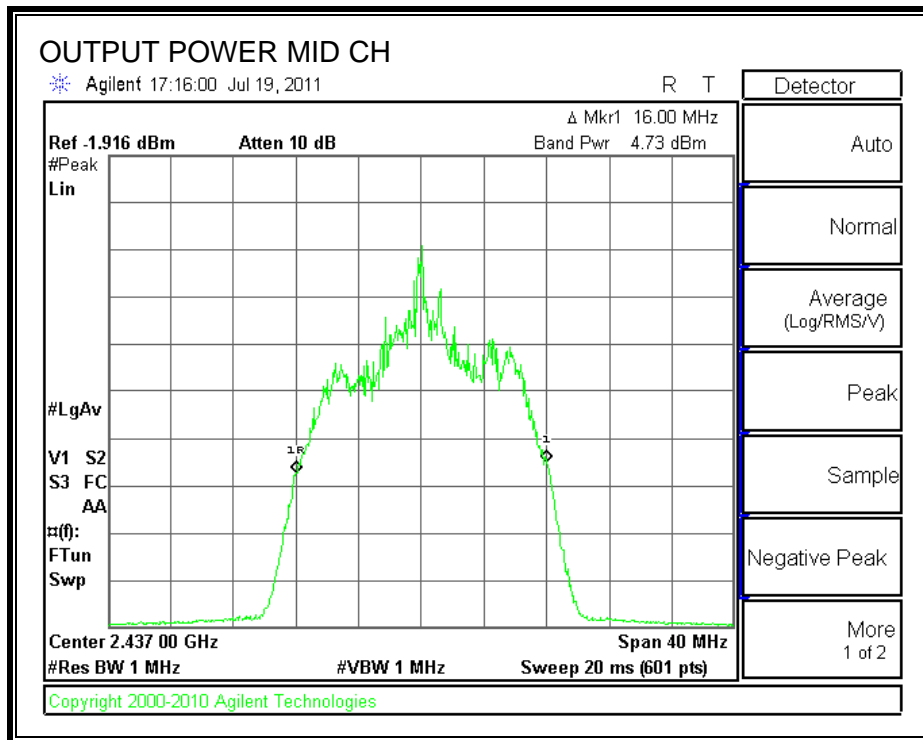
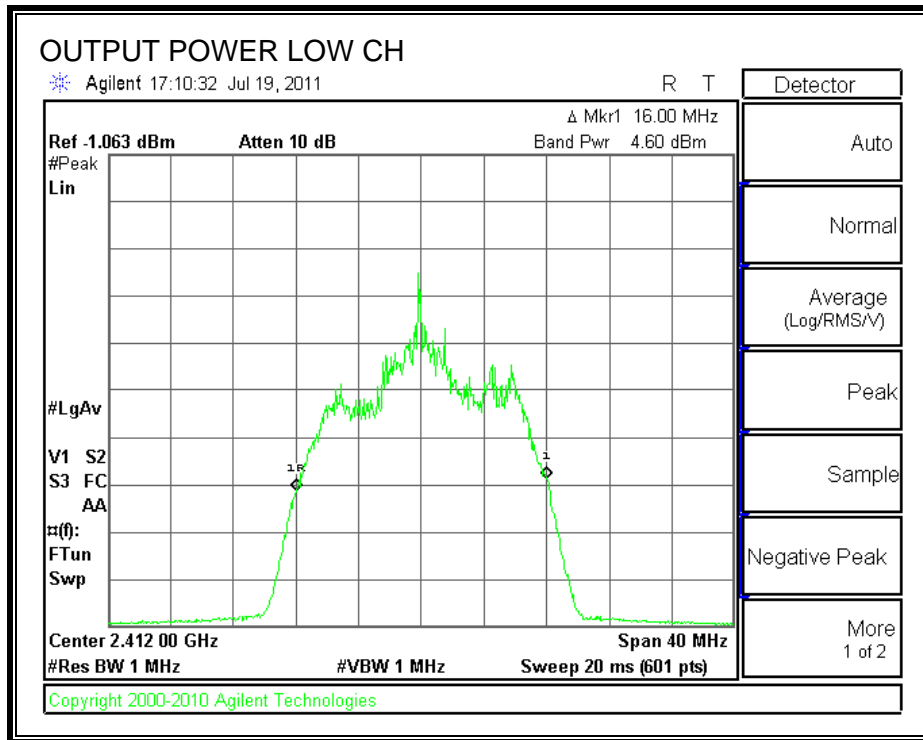

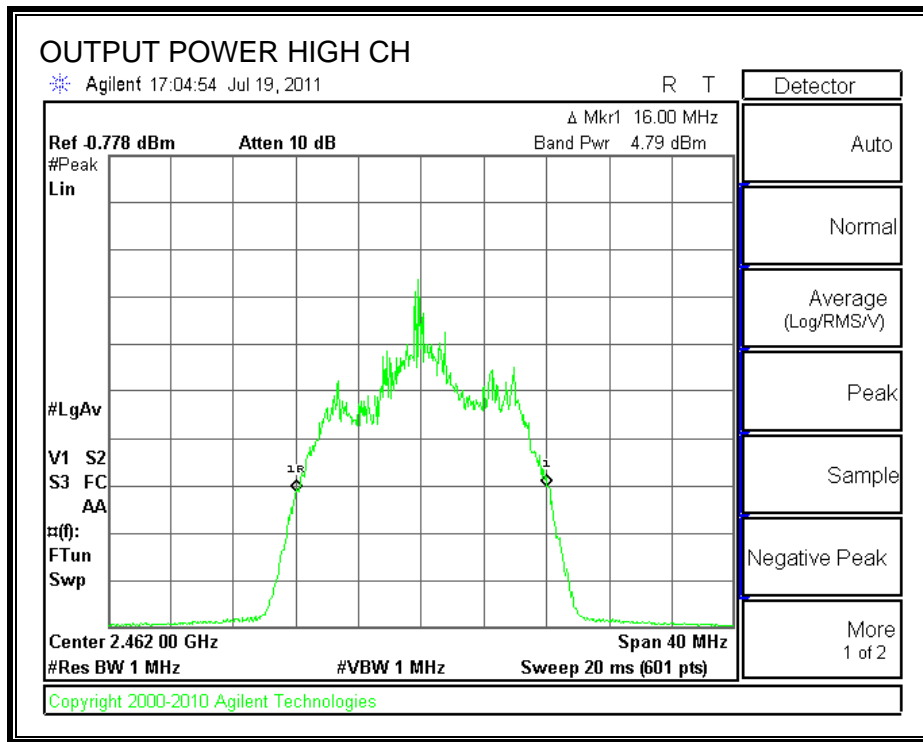

### 6.2.3. AVERAGE POWER

#### LIMITS

None; for reporting purposes only.

#### TEST PROCEDURE

The transmitter output is connected to a power meter.

#### RESULTS

The cable assembly insertion loss of 17.3 dB (including 16.2 dB pad and 1.1 dB cable) was entered as an offset in the power meter to allow for direct reading of power.

Channel	Frequency (MHz)	Power (dBm)
Low	2412	13.60
Middle	2437	13.90
High	2462	13.90



## 6.2.4. POWER SPECTRAL DENSITY

### LIMITS

FCC §15.247 (e)

IC RSS-210 A8.2 (b)

The power spectral density conducted from the transmitter to the antenna shall not be greater than 8 dBm in any 3 kHz band during any time interval of continuous transmission.

### TEST PROCEDURE

Output power was measured based on the use of a peak measurement, therefore the power spectral density was measured using PSD Option 1 in accordance with FCC document "Measurement of Digital Transmission Systems Operating under Section 15.247", March 23, 2005.

### RESULTS

Channel	Frequency (MHz)	PPSD (dBm)	Limit (dBm)	Margin (dB)
Low	2412	-9.33	8	-17.33
Middle	2437	-9.40	8	-17.40
High	2462	-9.65	8	-17.65

**POWER SPECTRAL DENSITY**

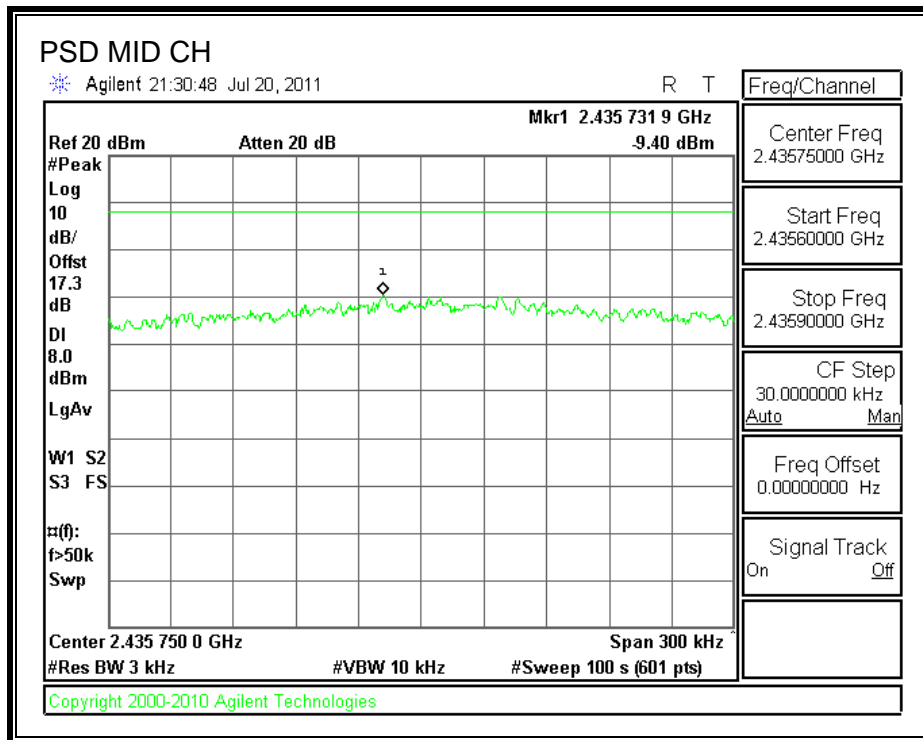
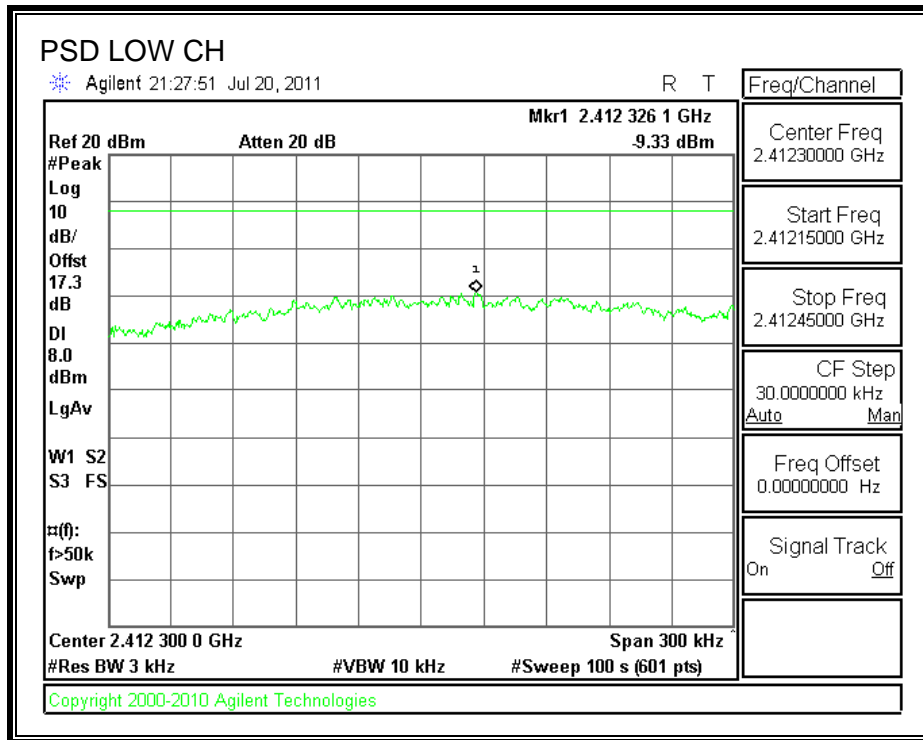

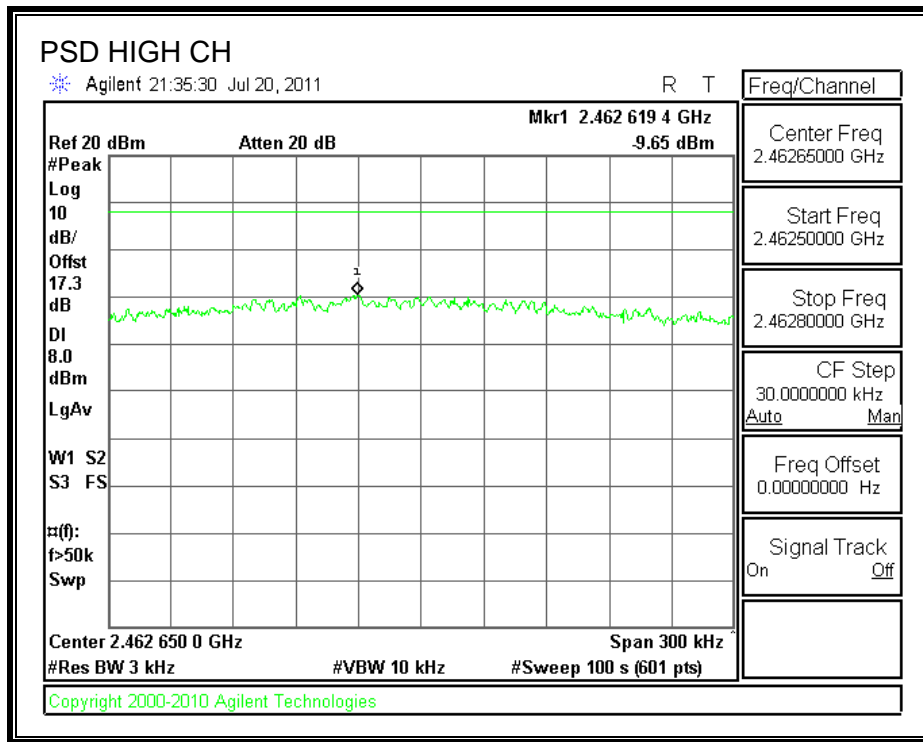

## 6.2.5. CONDUCTED SPURIOUS EMISSIONS

### LIMITS

FCC §15.247 (d)

IC RSS-210 A8.5

Output power was measured based on the use of a peak measurement, therefore the required attenuation is 20 dB.

### TEST PROCEDURE

The transmitter output is connected to a spectrum analyzer. The resolution bandwidth is set to 100 kHz. The video bandwidth is set to 300 kHz.

The spectrum from 30 MHz to 26 GHz is investigated with the transmitter set to the lowest, middle, and highest channels.

**RESULTS**

**SPURIOUS EMISSIONS, LOW CHANNEL**

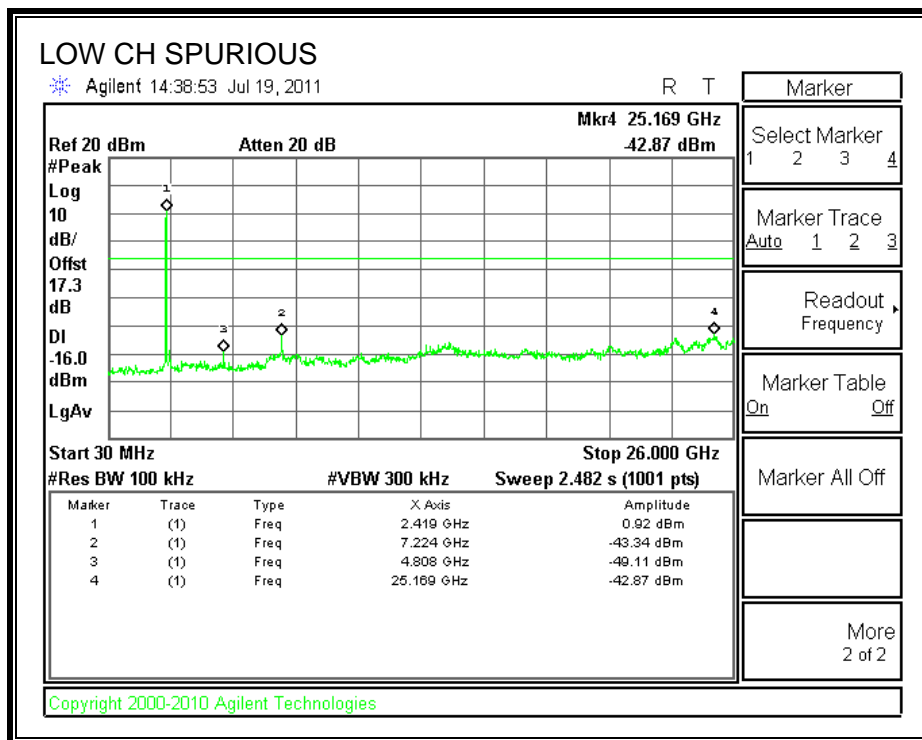
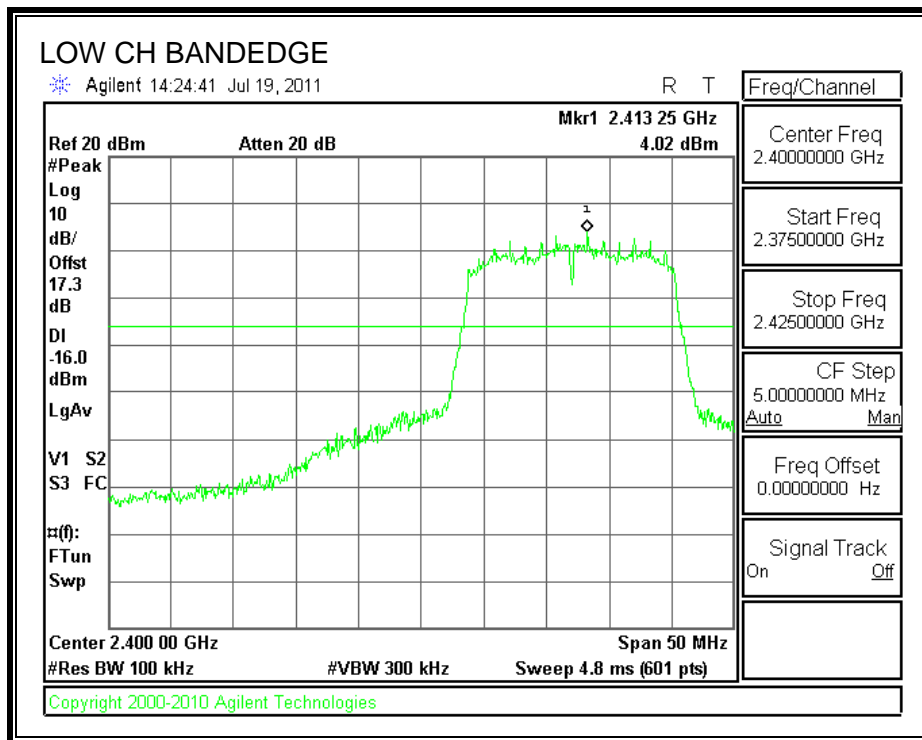

**SPURIOUS EMISSIONS, MID CHANNEL**

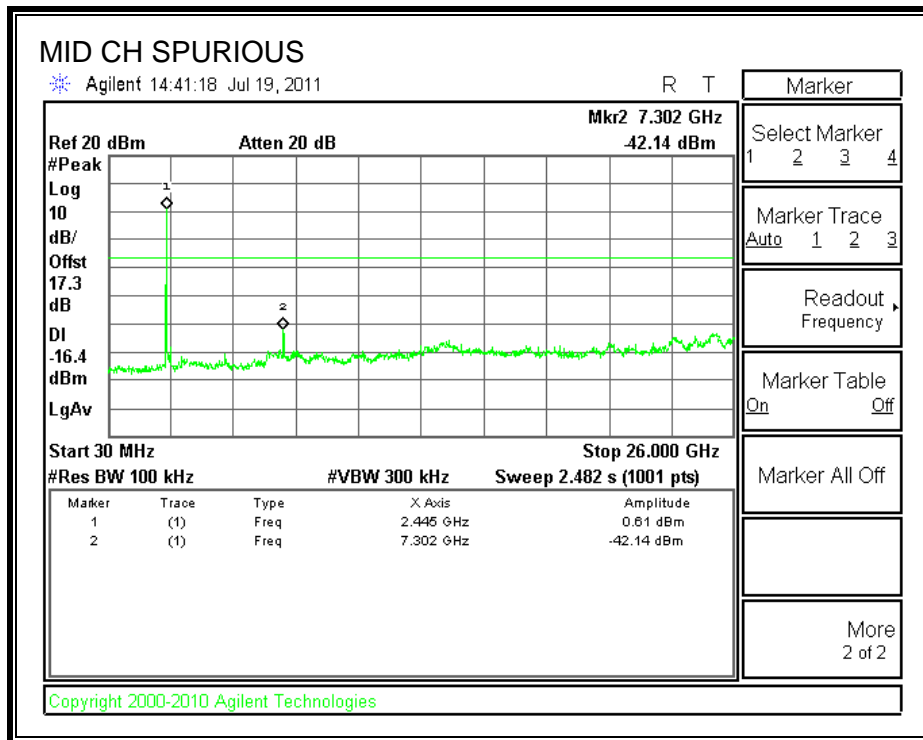
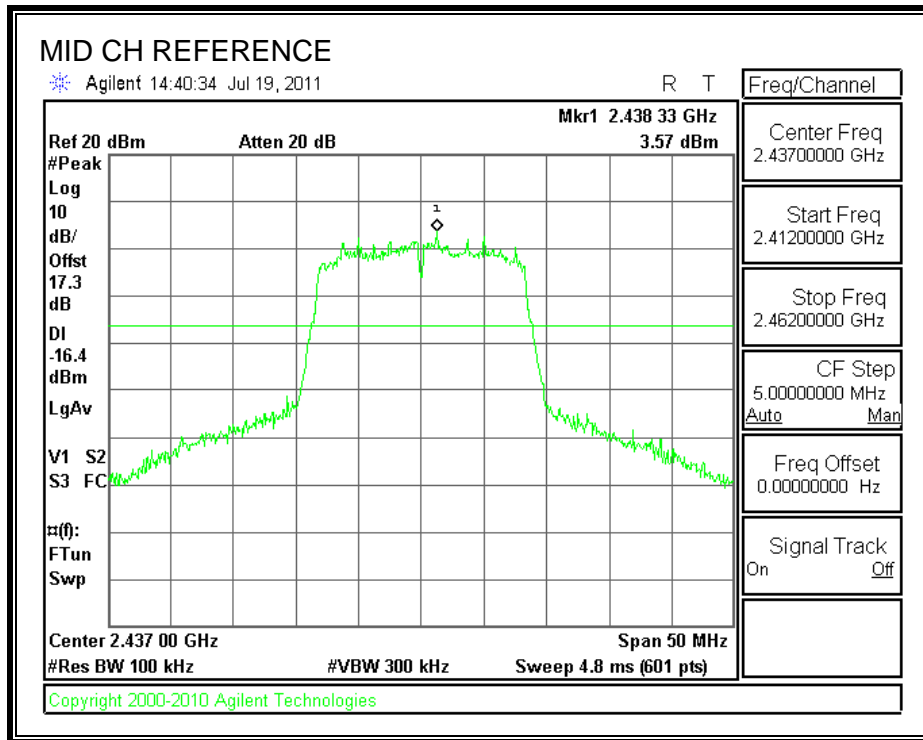

**SPURIOUS EMISSIONS, HIGH CHANNEL**

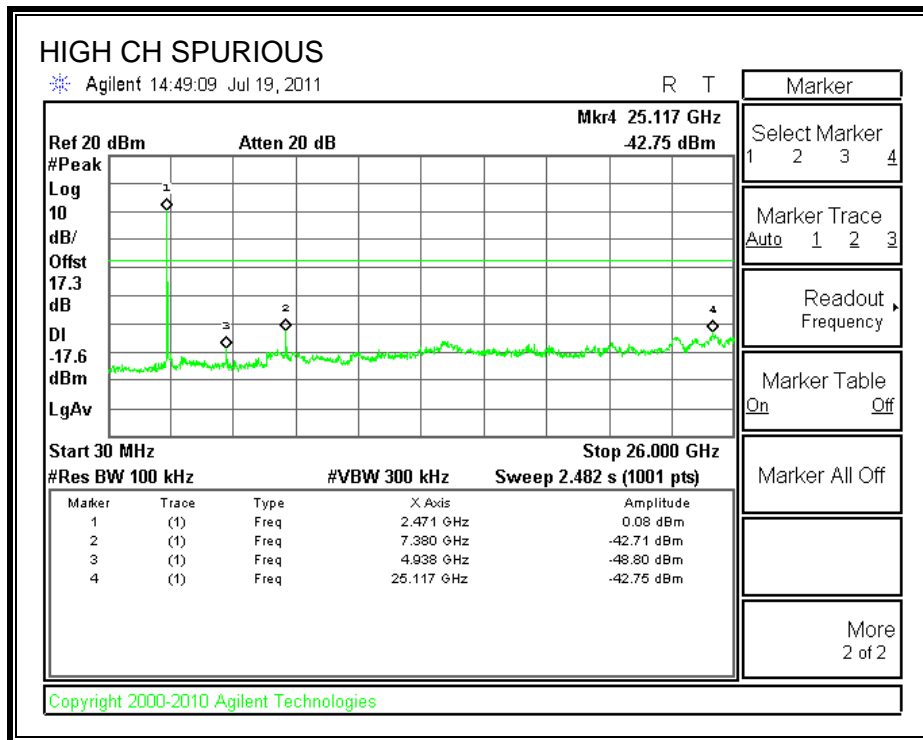
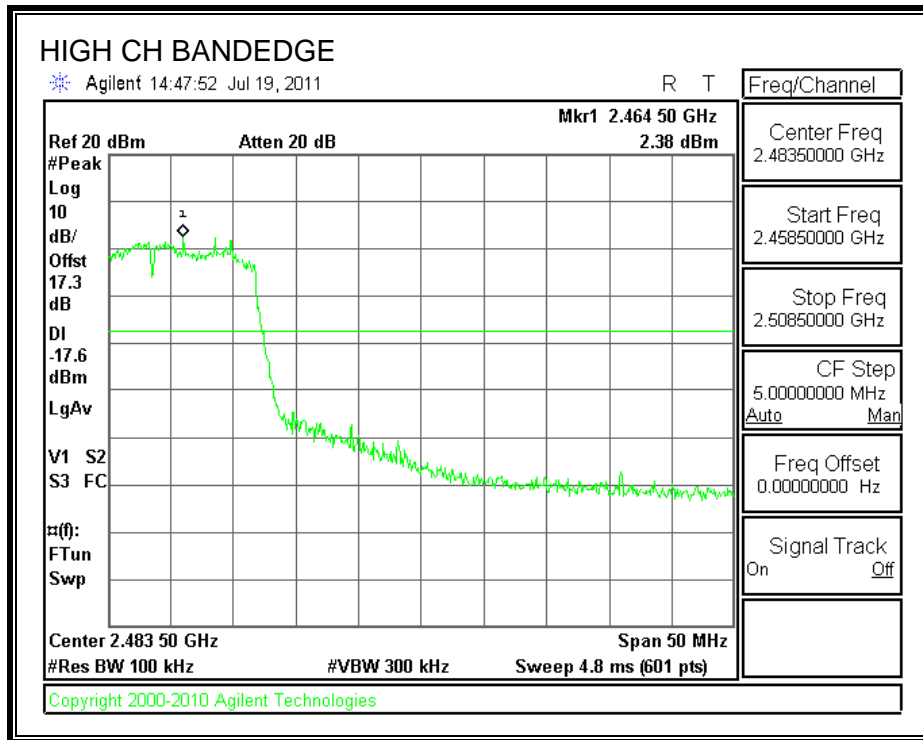

**6.3. 802.11n HT20 MODE IN THE 2.4 GHz BAND****6.3.1. 6 dB BANDWIDTH****LIMITS**

FCC §15.247 (a) (2)

IC RSS-210 A8.2 (a)

The minimum 6 dB bandwidth shall be at least 500 kHz.

**TEST PROCEDURE**

The transmitter output is connected to a spectrum analyzer. The RBW is set to 100 kHz and the VBW is set to 300 kHz. The sweep time is coupled.

**RESULTS**

Channel	Frequency (MHz)	6 dB Bandwidth (MHz)	Minimum Limit (MHz)
Low	2412	15.17	0.5
Middle	2437	15.17	0.5
High	2462	15.08	0.5



**6 dB BANDWIDTH**

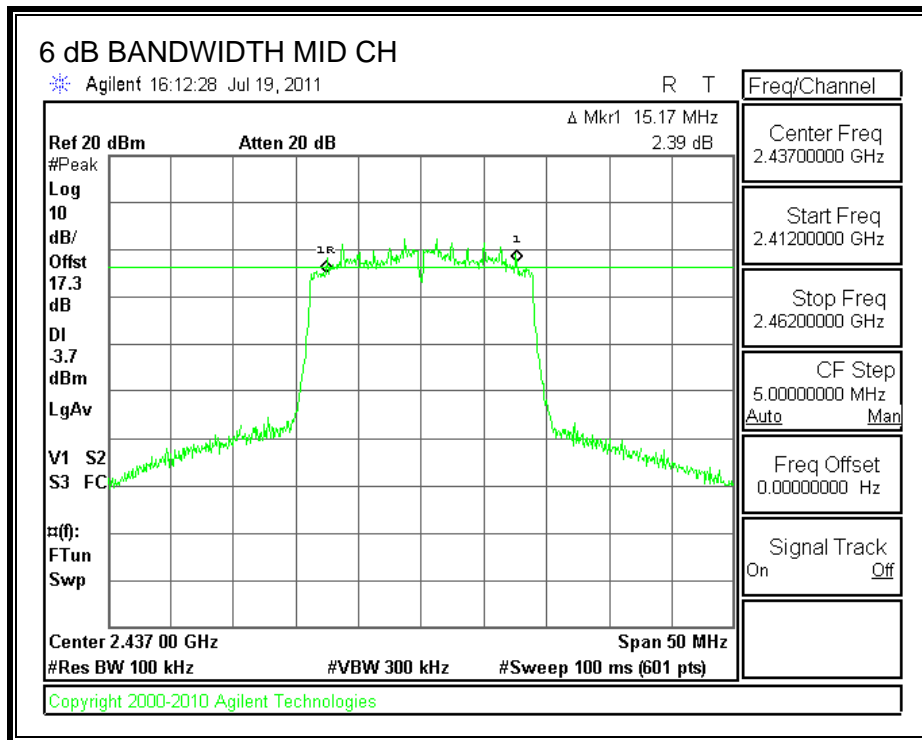
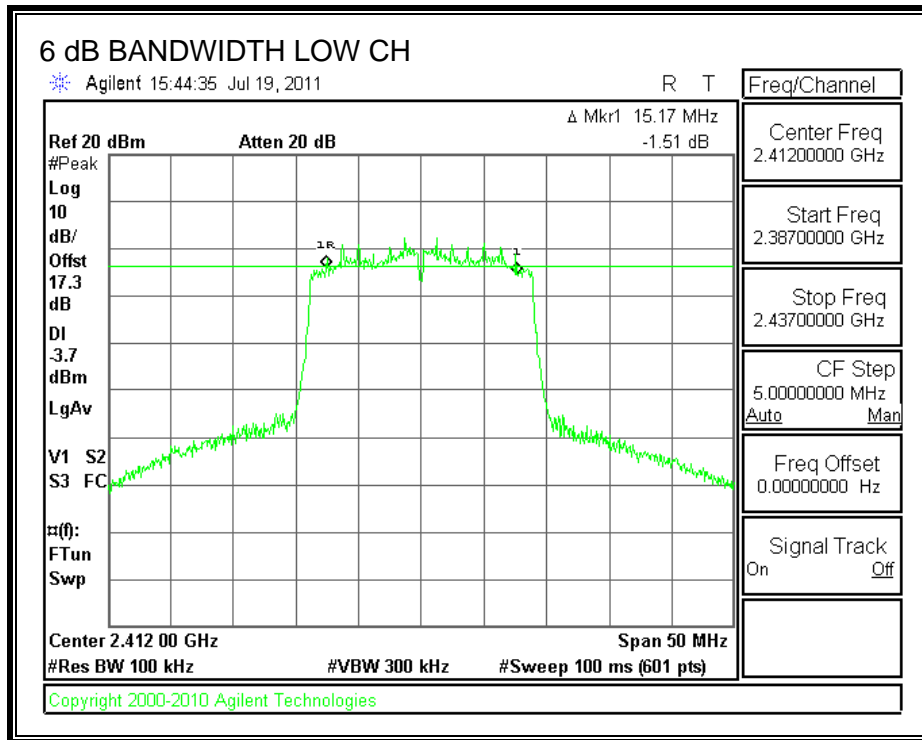

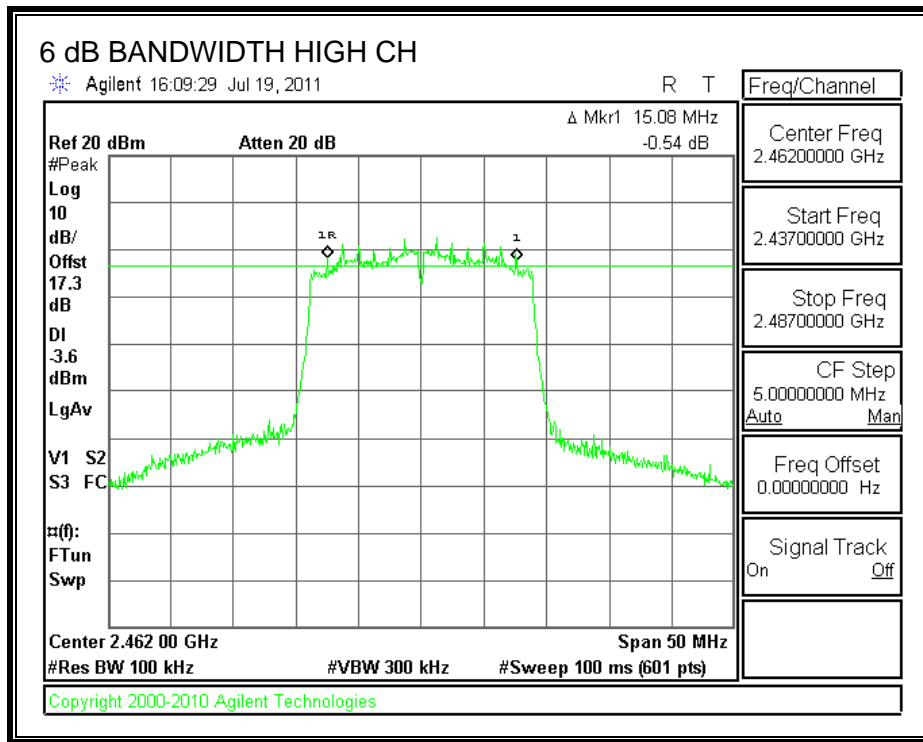

### 6.3.2. OUTPUT POWER

#### LIMITS

FCC §15.247 (b)

IC RSS-210 A8.4

The maximum antenna gain is less than or equal to 6 dBi, therefore the limit is 30 dBm.

#### TEST PROCEDURE

Peak power is measured using the Channel bandwidth Alternative peak output power procedure specified in "TCB Training for Devices covered under Scopes A1 - A4" by Joe Dichoso, May 2003.

#### RESULTS

Channel	Frequency (MHz)	Peak Power Reading (dBm)	Attenuator and Cable Offset (dB)	Output Power (dBm)	Limit (dBm)	Margin (dB)
Low	2412	3.45	17.3	20.75	30	-9.25
Middle	2437	3.51	17.3	20.81	30	-9.19
High	2462	3.60	17.3	20.90	30	-9.10

Attenuator and cable offset data was provided by the client

**OUTPUT POWER**

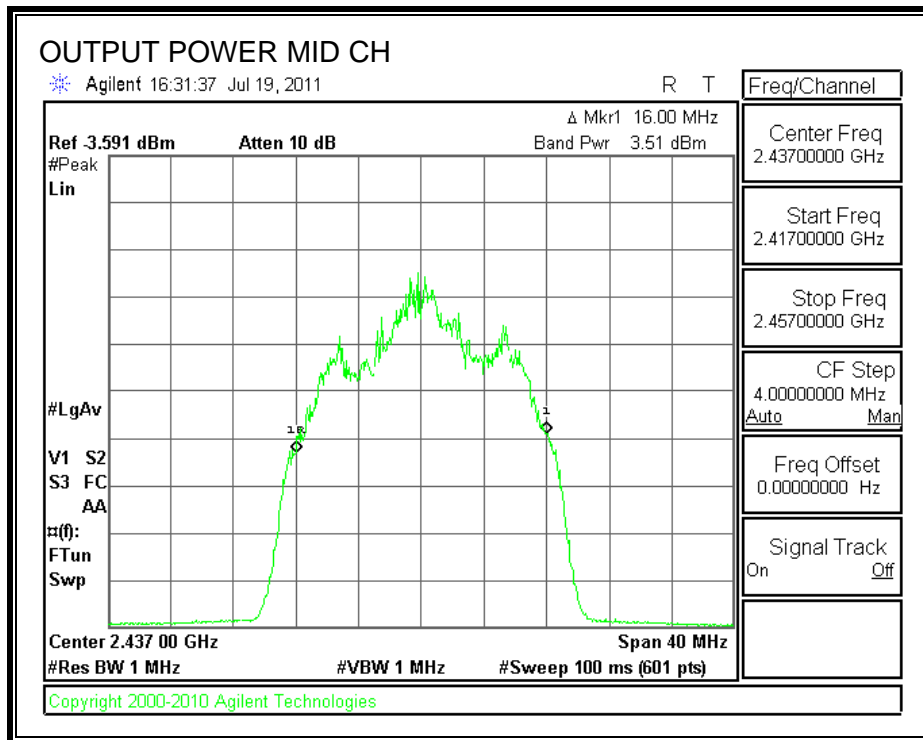
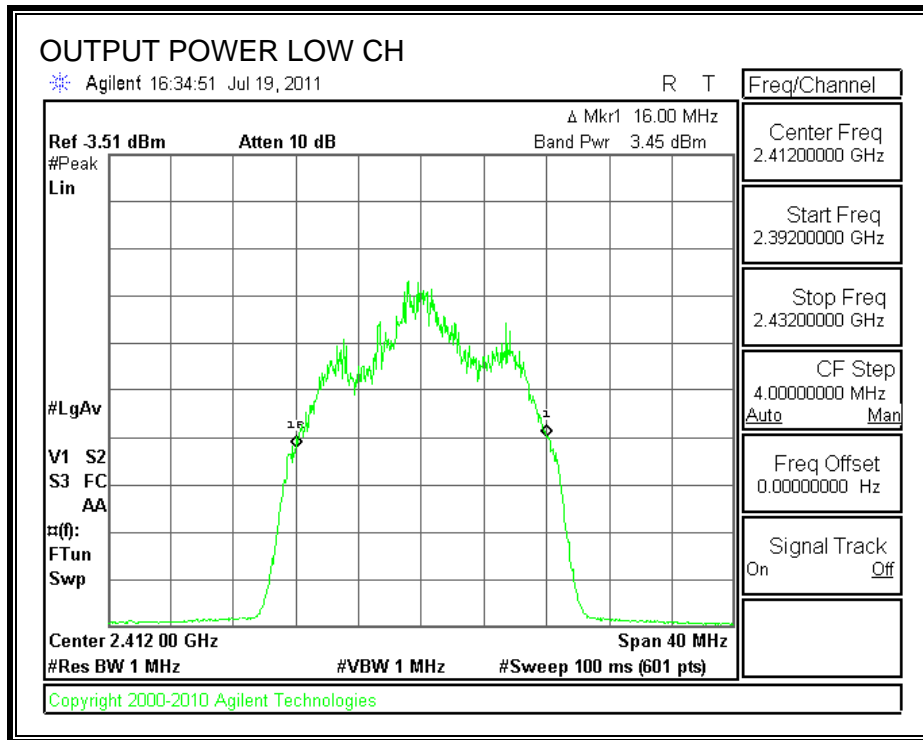

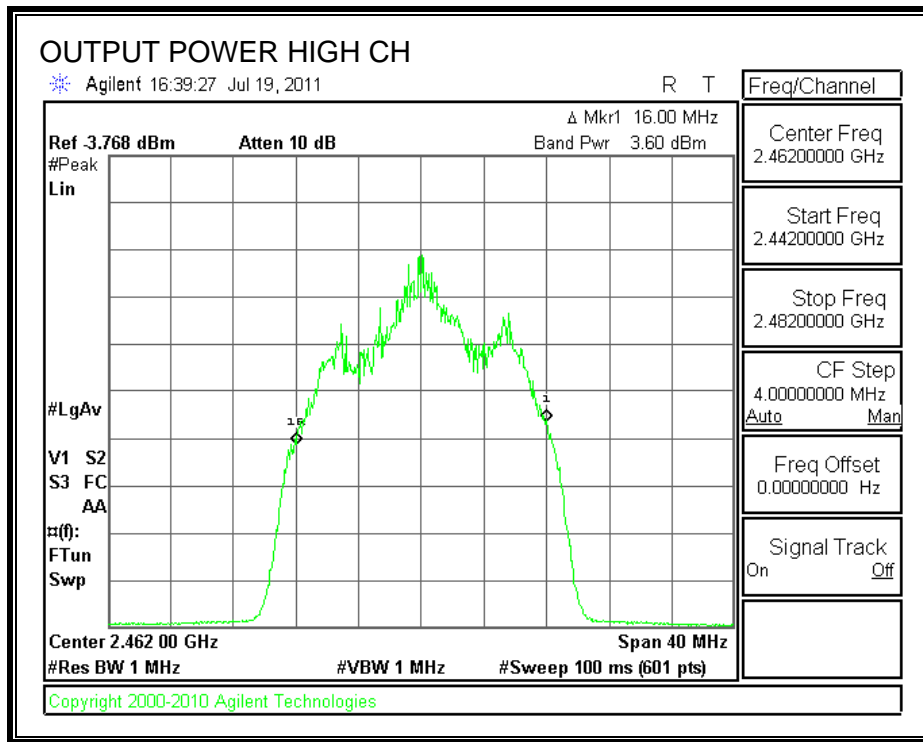

### 6.3.3. AVERAGE POWER

#### LIMITS

None; for reporting purposes only.

#### TEST PROCEDURE

The transmitter output is connected to a power meter.

#### RESULTS

The cable assembly insertion loss of 17.3 dB (including 16.2 dB pad and 1.1 dB cable) was entered as an offset in the power meter to allow for direct reading of power.

Channel	Frequency (MHz)	Power (dBm)
Low	2412	12.50
Middle	2437	12.80
High	2462	12.80

### 6.3.4. POWER SPECTRAL DENSITY

#### LIMITS

FCC §15.247 (e)

IC RSS-210 A8.2 (b)

The power spectral density conducted from the transmitter to the antenna shall not be greater than 8 dBm in any 3 kHz band during any time interval of continuous transmission.

#### TEST PROCEDURE

Output power was measured based on the use of a peak measurement, therefore the power spectral density was measured using PSD Option 1 in accordance with FCC document "Measurement of Digital Transmission Systems Operating under Section 15.247", March 23, 2005.

#### RESULTS

Channel	Frequency (MHz)	PPSD (dBm)	Limit (dBm)	Margin (dB)
Low	2412	-10.74	8	-18.74
Middle	2437	-10.62	8	-18.62
High	2462	-10.14	8	-18.14

**POWER SPECTRAL DENSITY**

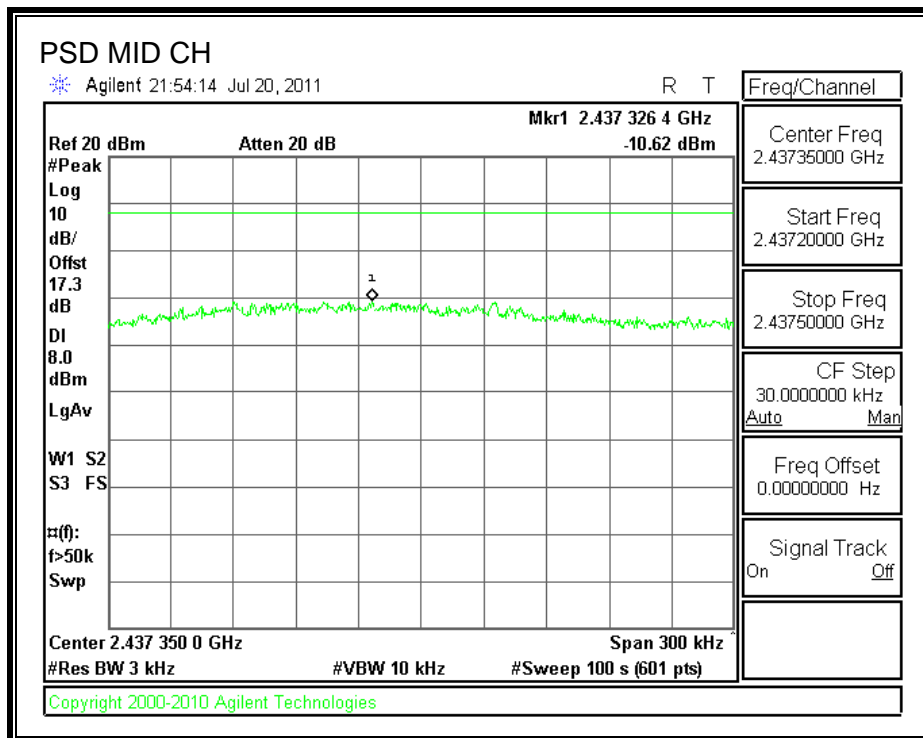
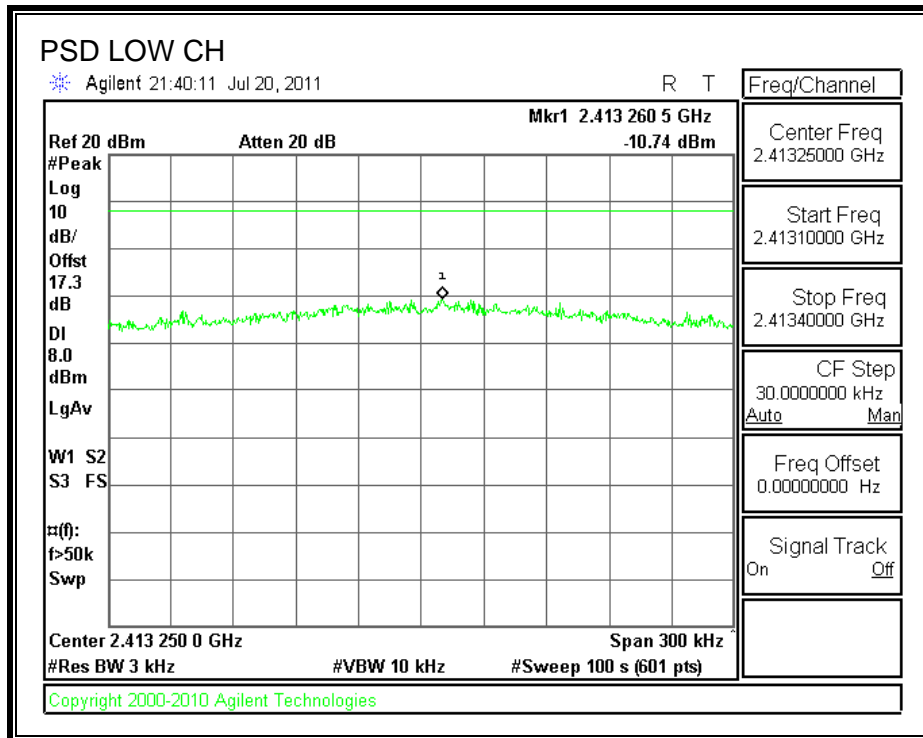



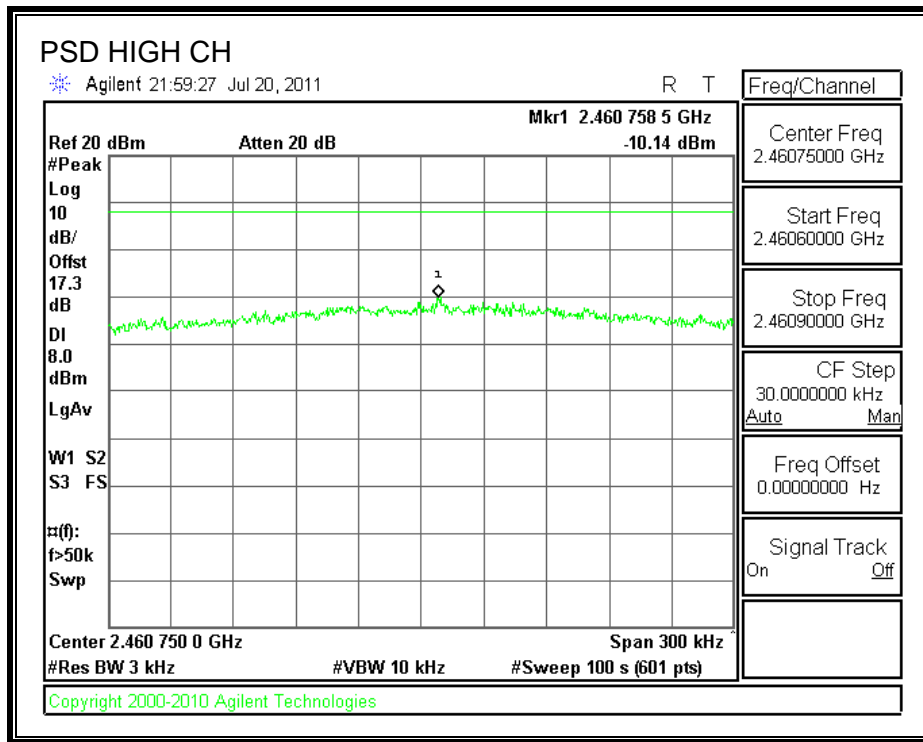

### **6.3.5. CONDUCTED SPURIOUS EMISSIONS**

#### **LIMITS**

FCC §15.247 (d)

IC RSS-210 A8.5

Output power was measured based on the use of a peak measurement, therefore the required attenuation is 20 dB.

#### **TEST PROCEDURE**

The transmitter output is connected to a spectrum analyzer. The resolution bandwidth is set to 100 kHz. The video bandwidth is set to 300 kHz.

The spectrum from 30 MHz to 26 GHz is investigated with the transmitter set to the lowest, middle, and highest channels.

**RESULTS**

**SPURIOUS EMISSIONS, LOW CHANNEL**

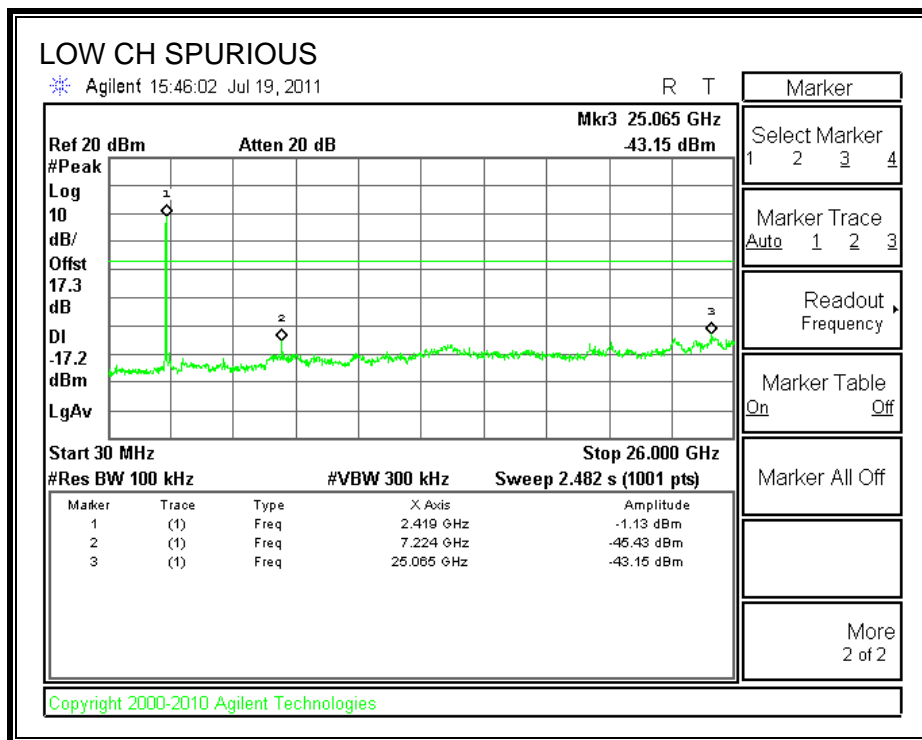
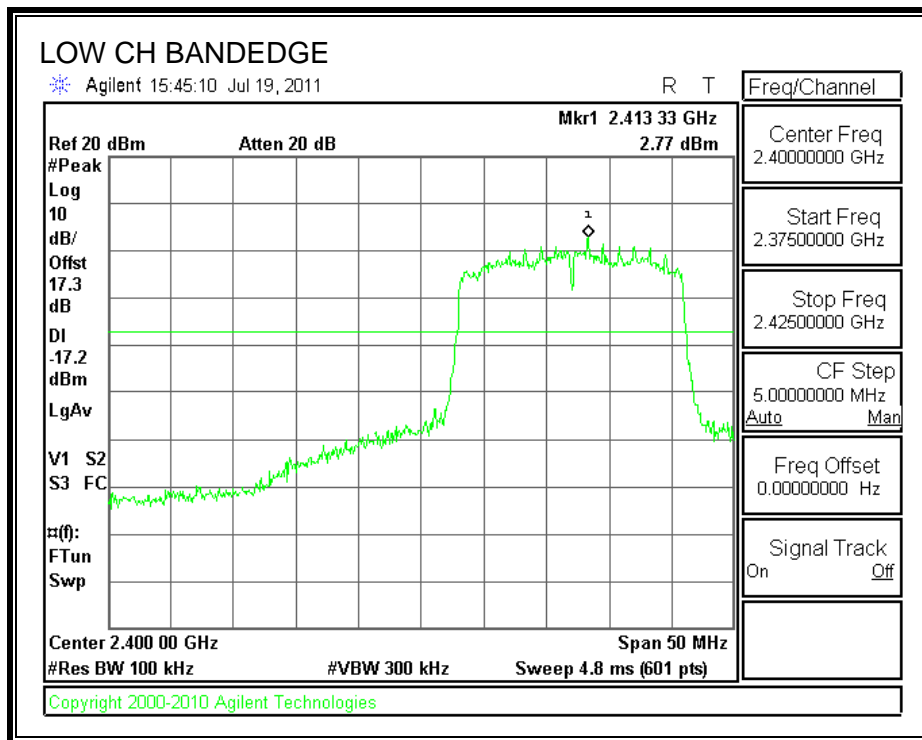

**SPURIOUS EMISSIONS, MID CHANNEL**

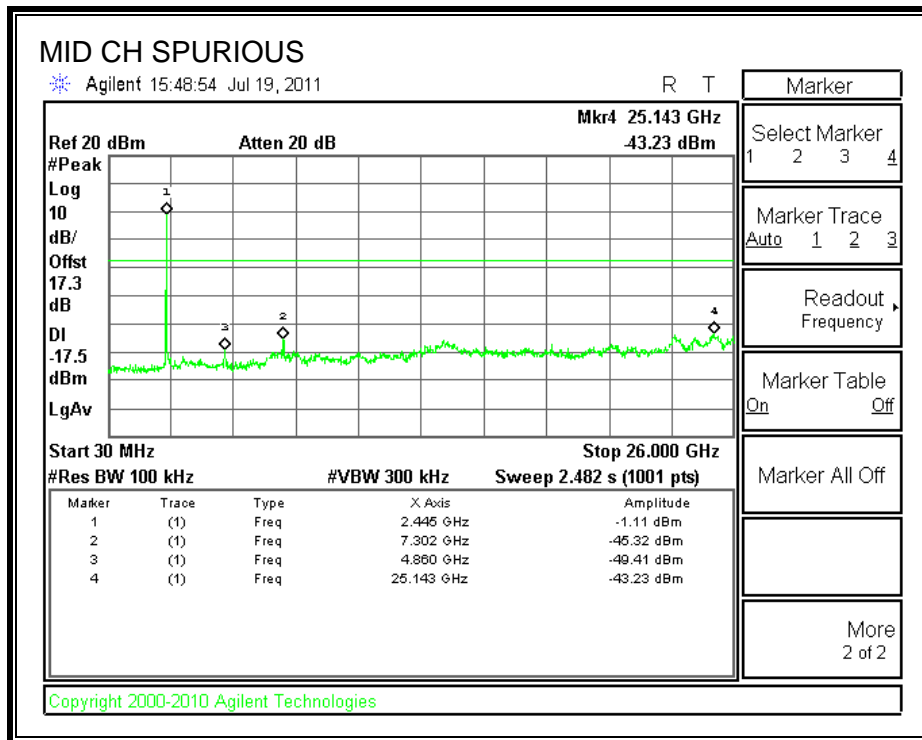
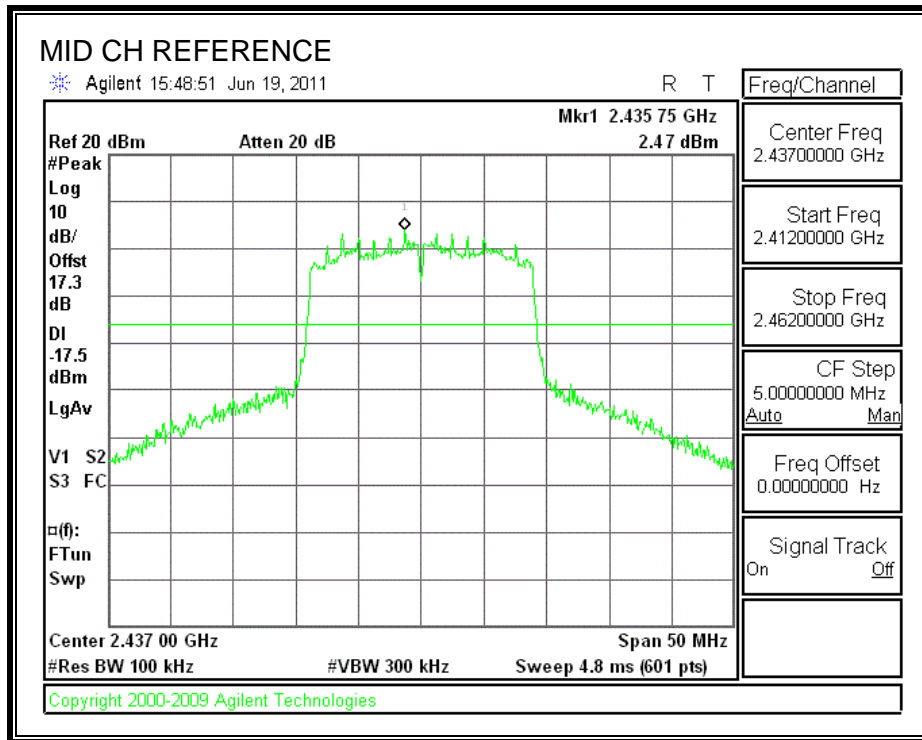

**SPURIOUS EMISSIONS, HIGH CHANNEL**

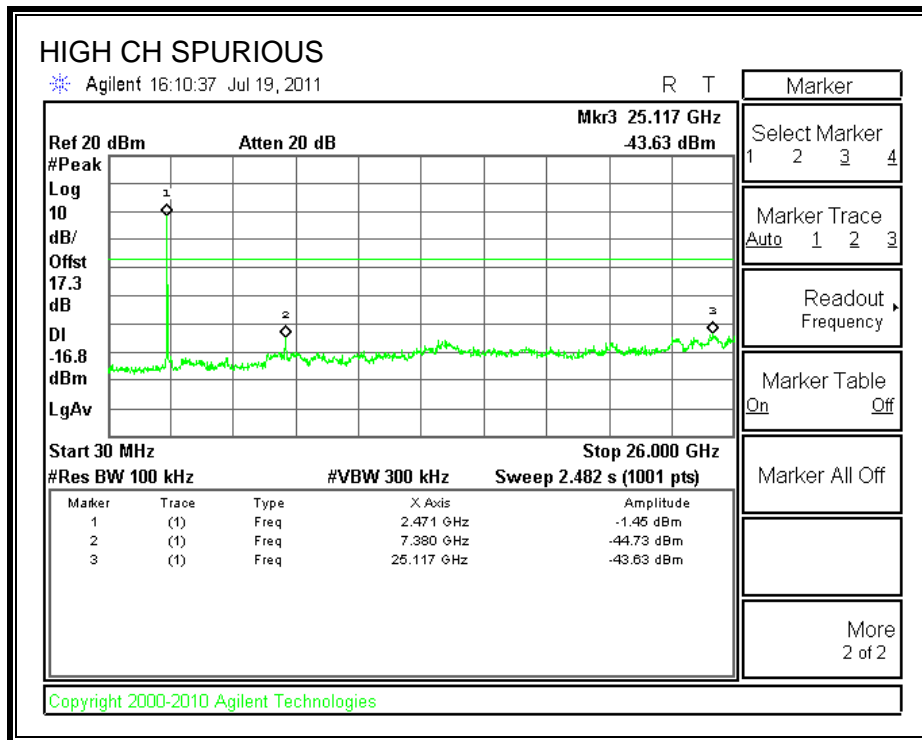
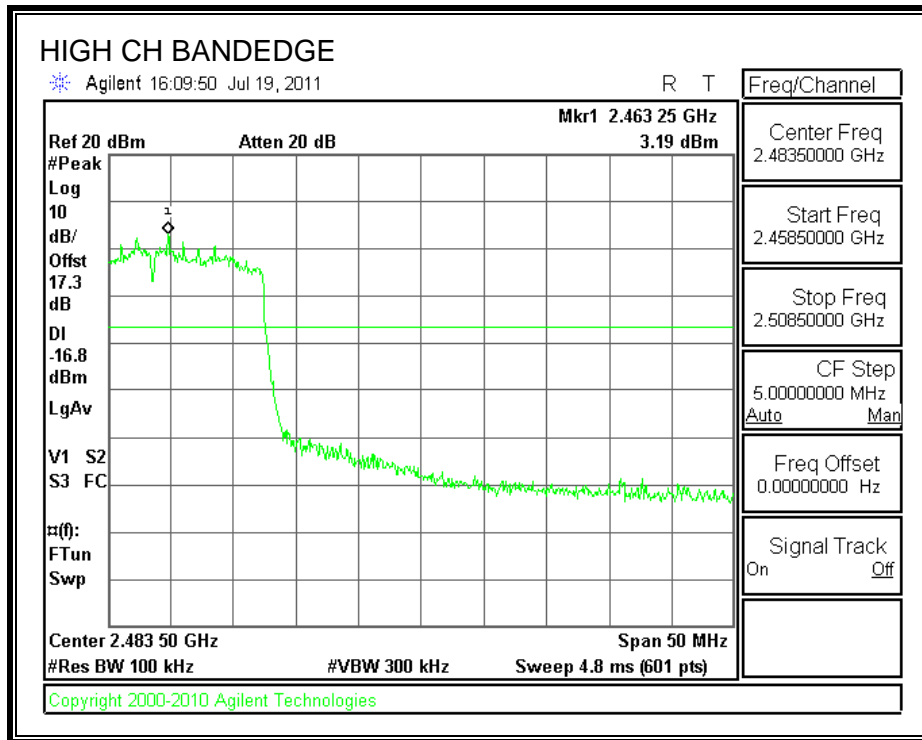

## 7. RADIATED TEST RESULTS

### 7.1. LIMITS AND PROCEDURE

#### LIMITS

FCC §15.205 and §15.209

IC RSS-210 Clause 2.6 (Transmitter)

IC RSS-GEN Clause 6 (Receiver)

Frequency Range (MHz)	Field Strength Limit (uV/m) at 3 m	Field Strength Limit (dBuV/m) at 3 m
30 - 88	100	40
88 - 216	150	43.5
216 - 960	200	46
Above 960	500	54

#### TEST PROCEDURE

The EUT is placed on a non-conducting table 80 cm above the ground plane. The antenna to EUT distance is 3 meters. The EUT is configured in accordance with ANSI C63.4. The EUT is set to transmit in a continuous mode.

For measurements below 1 GHz the resolution bandwidth is set to 100 kHz for peak detection measurements or 120 kHz for quasi-peak detection measurements. Peak detection is used unless otherwise noted as quasi-peak.

For measurements above 1 GHz the resolution bandwidth is set to 1 MHz, the video bandwidth is set to 1 MHz for peak measurements and 10 Hz for average measurements.

The spectrum from 30 MHz to 26 GHz is investigated with the transmitter set to the lowest, middle, and highest channels in the 2.4 GHz band.

The frequency range of interest is monitored at a fixed antenna height and EUT azimuth. The EUT is rotated through 360 degrees to maximize emissions received. The antenna is scanned from 1 to 4 meters above the ground plane to further maximize the emission. Measurements are made with the antenna polarized in both the vertical and the horizontal positions.

## 7.2. TRANSMITTER ABOVE 1 GHz

### 7.2.1. 802.11b MODE IN THE 2.4 GHz BAND

#### RESTRICTED BANDEDGE (LOW CHANNEL, HORIZONTAL)

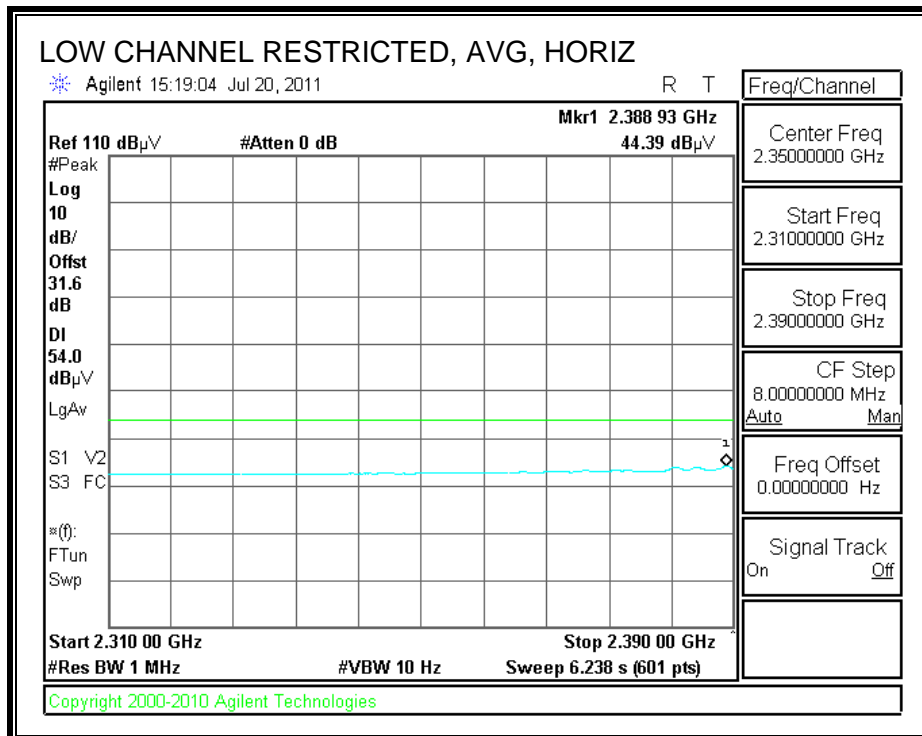
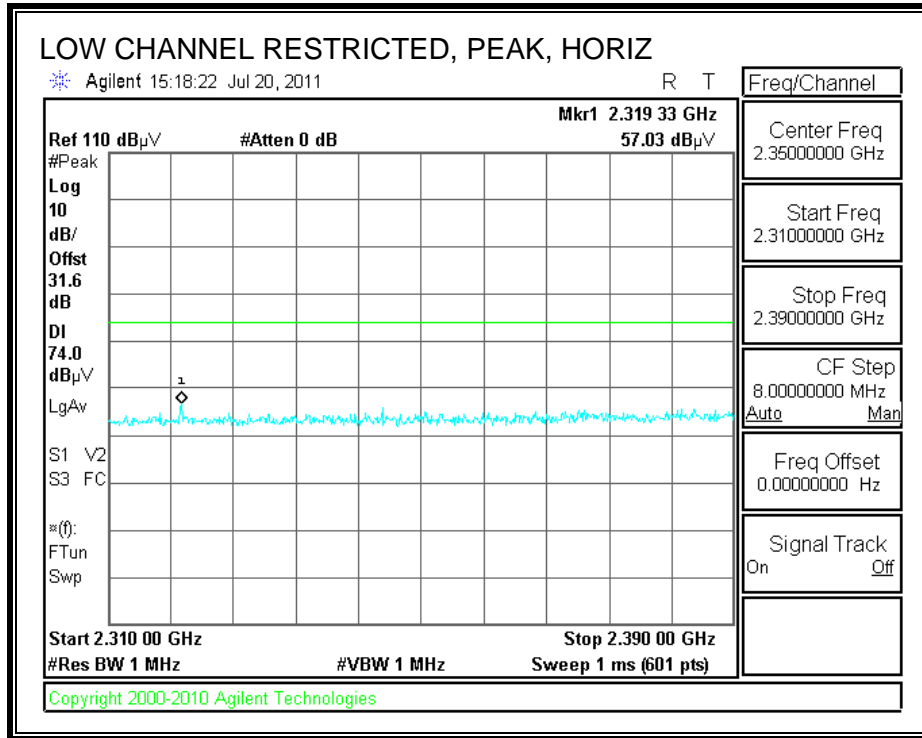

**RESTRICTED BANDEDGE (LOW CHANNEL, VERTICAL)**

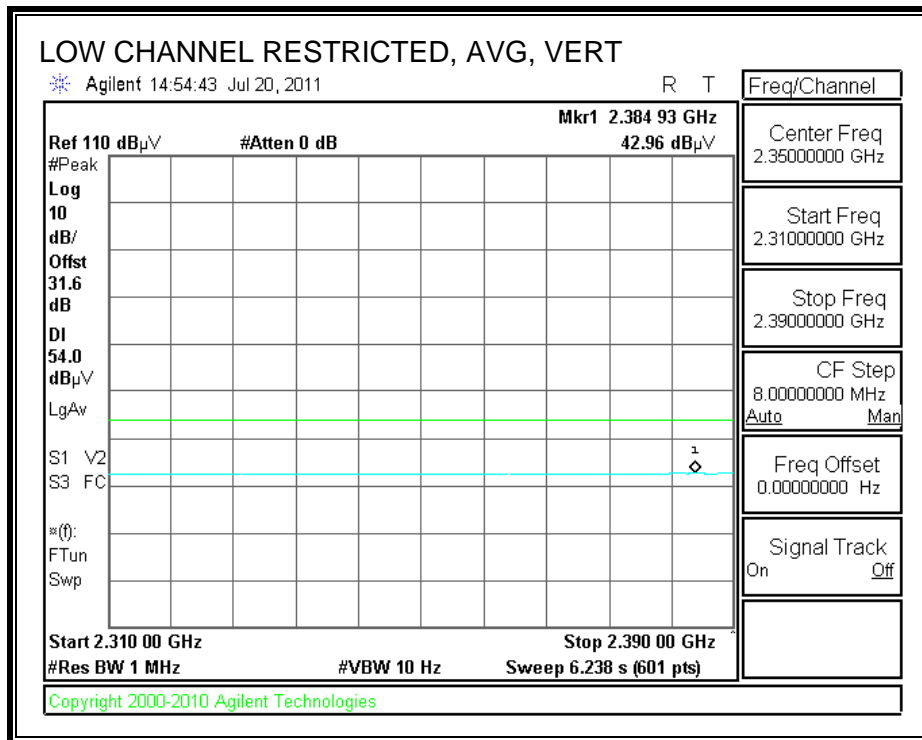
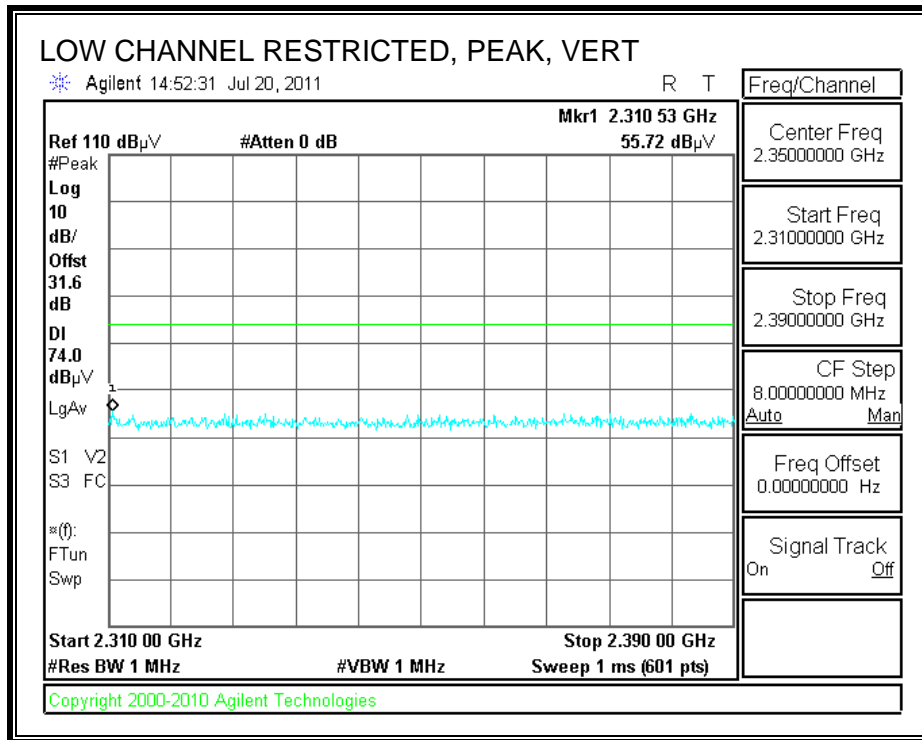



**RESTRICTED BANDEDGE (HIGH CHANNEL, HORIZONTAL)**

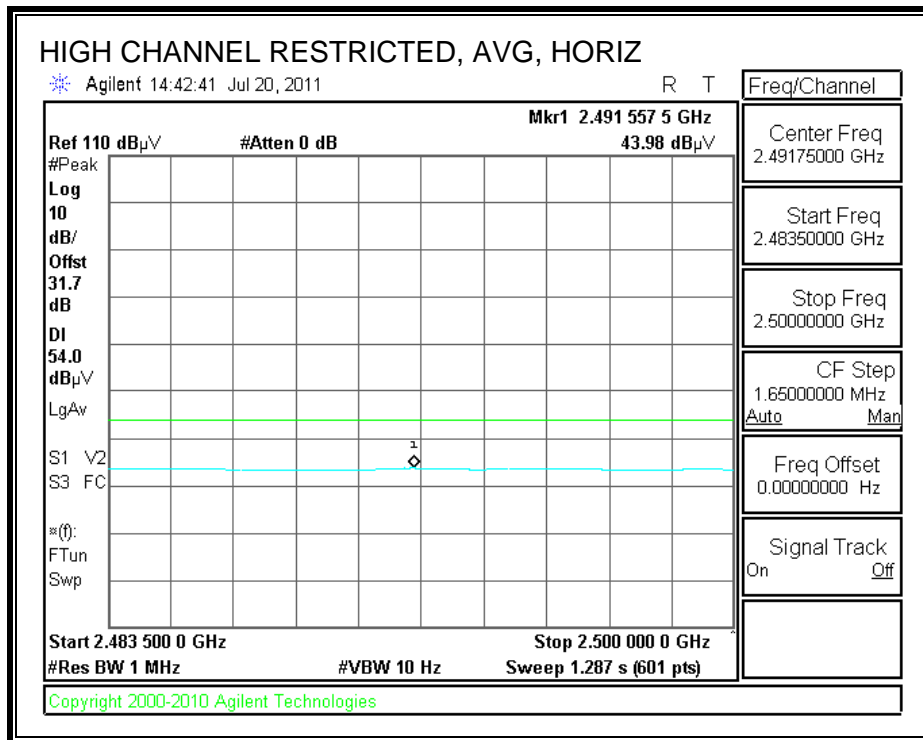
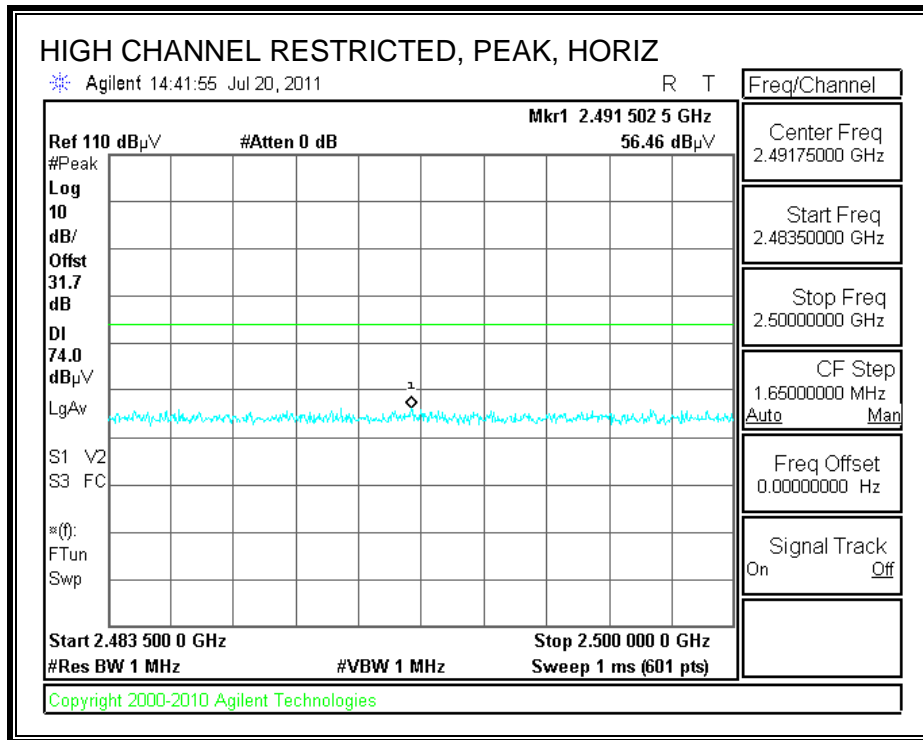

**RESTRICTED BANDEDGE (HIGH CHANNEL, VERTICAL)**

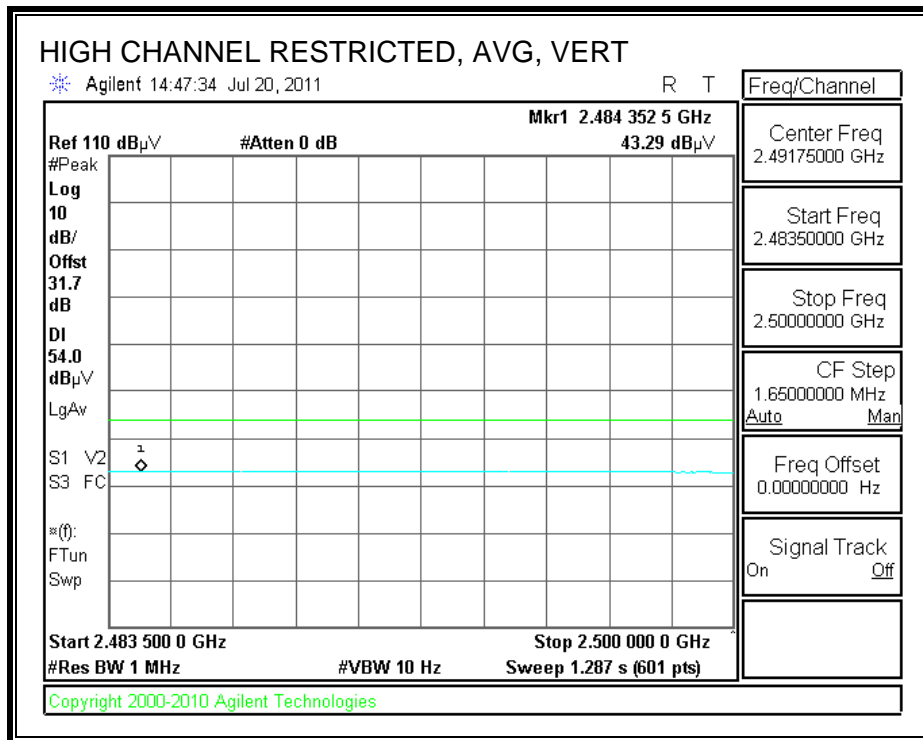
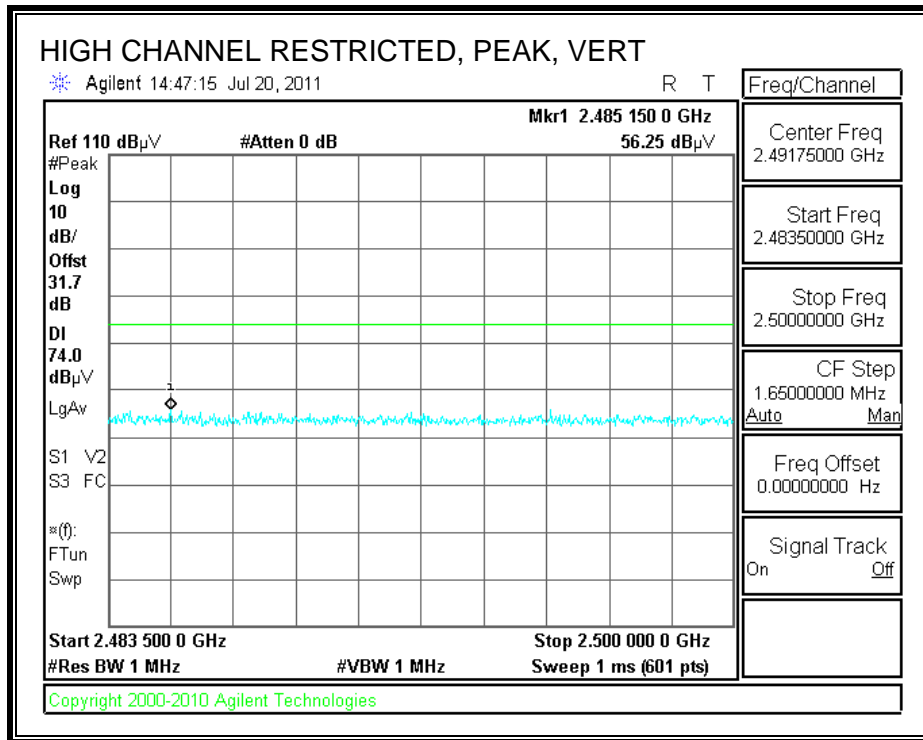

**HARMONICS AND SPURIOUS EMISSIONS**

High Frequency Measurement													
Compliance Certification Services, Fremont 5m Chamber													
Test Engr:		Vien Tran											
Date:		07/20/11											
Project #:		11U13739											
Company:		LG Electronics Inc.,											
Test Target:		FCC Class B											
Mode Oper:		Tx 11b Mode											
f	Measurement Frequency			Amp	Preamp Gain			Average Field Strength Limit					
Dist	Distance to Antenna			D Corr	Distance Correct to 3 meters			Peak Field Strength Limit					
Read	Analyzer Reading			Avg	Average Field Strength @ 3 m			Margin vs. Average Limit					
AF	Antenna Factor			Peak	Calculated Peak Field Strength			Margin vs. Peak Limit					
CL	Cable Loss			HPF	High Pass Filter								
f	Dist	Read	AF	CL	Amp	D Corr	Fltr	Corr.	Limit	Margin	Ant. Pol.	Det.	Notes
GHz	(m)	dBuV	dB/m	dB	dB	dB	dB	dBuV/m	dBuV/m	dB	V/H	P/A/QP	
<b>LOW CHANNEL, 2412MHz</b>													
4.824	3.0	47.4	32.7	5.8	-34.8	0.0	0.0	51.1	74.0	-22.9	V	P	
4.824	3.0	44.4	32.7	5.8	-34.8	0.0	0.0	48.0	54.0	-6.0	V	A	
4.824	3.0	44.3	32.7	5.8	-34.8	0.0	0.0	47.9	74.0	-26.1	H	P	
4.824	3.0	40.8	32.7	5.8	-34.8	0.0	0.0	44.4	54.0	-9.6	H	A	
<b>MID CHANNEL, 2437MHz</b>													
4.874	3.0	47.3	32.7	5.8	-34.8	0.0	0.0	51.0	74.0	-23.0	V	P	
4.874	3.0	44.3	32.7	5.8	-34.8	0.0	0.0	48.0	54.0	-6.0	V	A	
7.311	3.0	37.5	35.5	7.3	-34.1	0.0	0.0	46.1	74.0	-27.9	V	P	
7.311	3.0	29.2	35.5	7.3	-34.1	0.0	0.0	37.9	54.0	-16.1	V	A	
4.874	3.0	45.5	32.7	5.8	-34.8	0.0	0.0	49.2	74.0	-24.8	H	P	
4.874	3.0	42.6	32.7	5.8	-34.8	0.0	0.0	46.4	54.0	-7.6	H	A	
7.311	3.0	35.4	35.5	7.3	-34.1	0.0	0.0	44.0	74.0	-30.0	H	P	
7.311	3.0	25.2	35.5	7.3	-34.1	0.0	0.0	33.8	54.0	-20.2	H	A	
<b>HIGH CHANNEL, 2462MHz</b>													
4.924	3.0	45.8	32.7	5.9	-34.8	0.0	0.0	49.6	74.0	-24.4	V	P	
4.924	3.0	43.0	32.7	5.9	-34.8	0.0	0.0	46.8	54.0	-7.2	V	A	
7.386	3.0	37.8	35.6	7.3	-34.1	0.0	0.0	46.6	74.0	-27.4	V	P	
7.386	3.0	29.7	35.6	7.3	-34.1	0.0	0.0	38.5	54.0	-15.5	V	A	
4.924	3.0	42.1	32.7	5.9	-34.8	0.0	0.0	45.9	74.0	-28.1	H	P	
4.924	3.0	37.9	32.7	5.9	-34.8	0.0	0.0	41.7	54.0	-12.3	H	A	
7.386	3.0	37.1	35.6	7.3	-34.1	0.0	0.0	45.9	74.0	-28.1	H	P	
7.386	3.0	27.1	35.6	7.3	-34.1	0.0	0.0	35.9	54.0	-18.1	H	A	
Rev. 4.1.2.7													
Note: No other emissions were detected above the system noise floor.													

### 7.2.2. 802.11g MODE IN THE 2.4 GHz BAND

#### RESTRICTED BANDEDGE (LOW CHANNEL, HORIZONTAL)

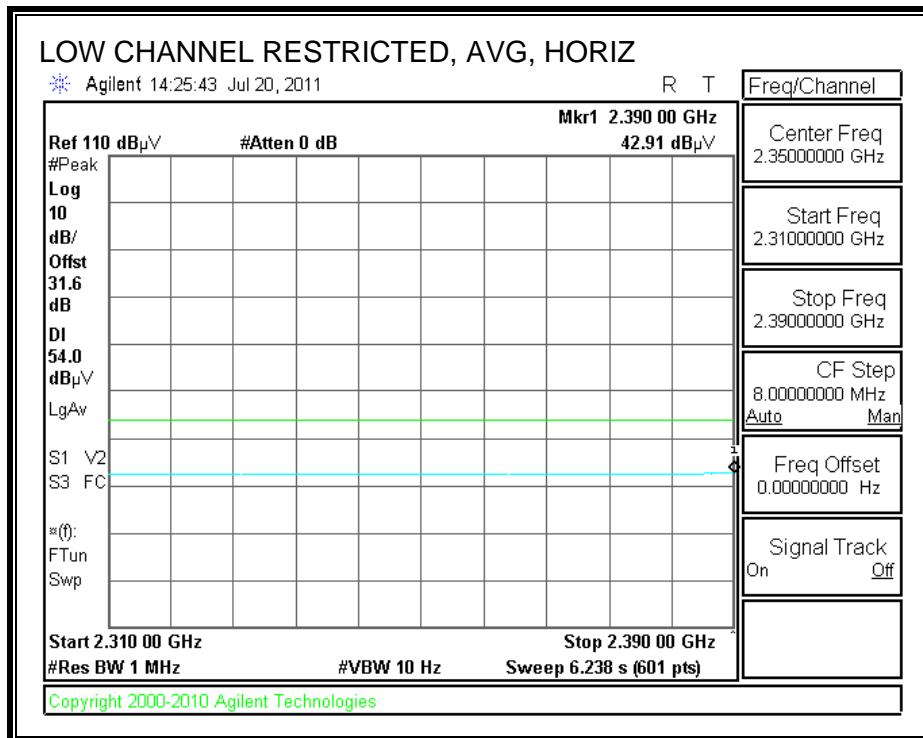
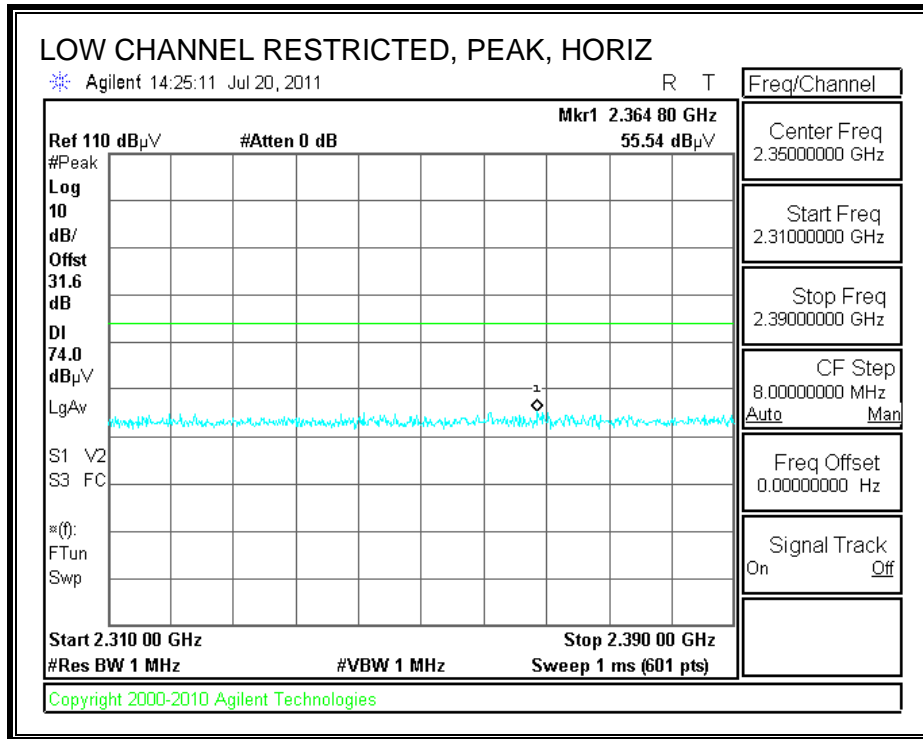

**RESTRICTED BANDEDGE (LOW CHANNEL, VERTICAL)**

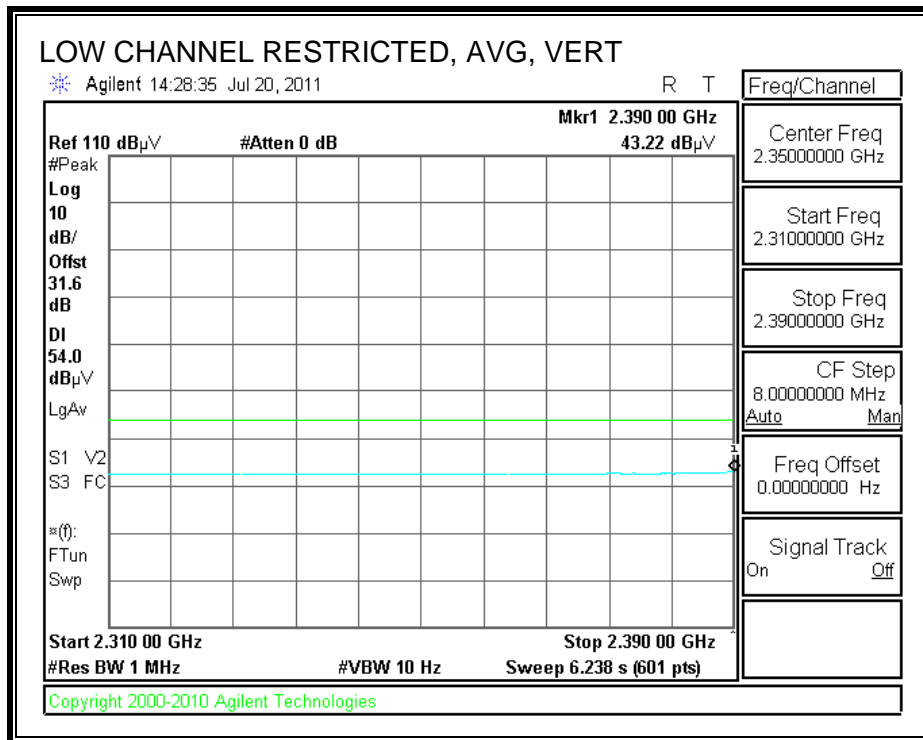
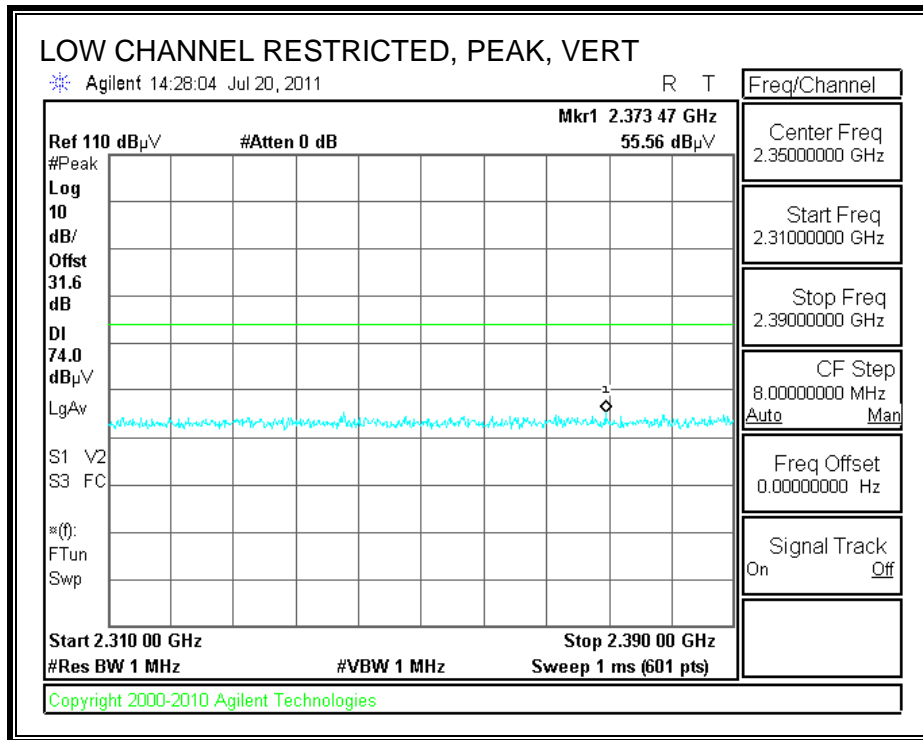

**RESTRICTED BANDEDGE (HIGH CHANNEL, HORIZONTAL)**

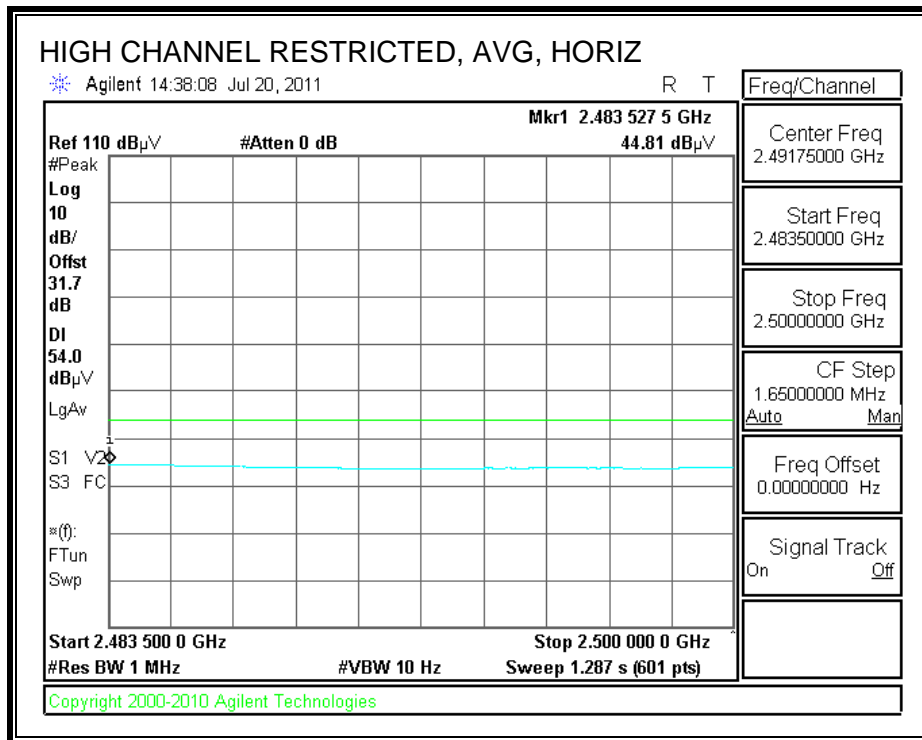
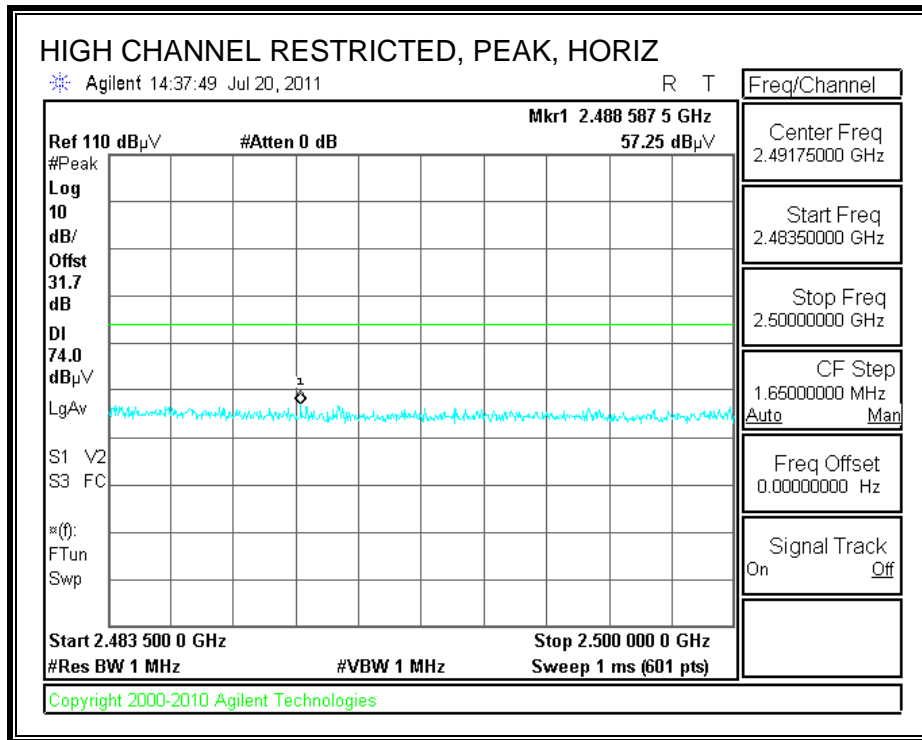

**RESTRICTED BANDEDGE (HIGH CHANNEL, VERTICAL)**

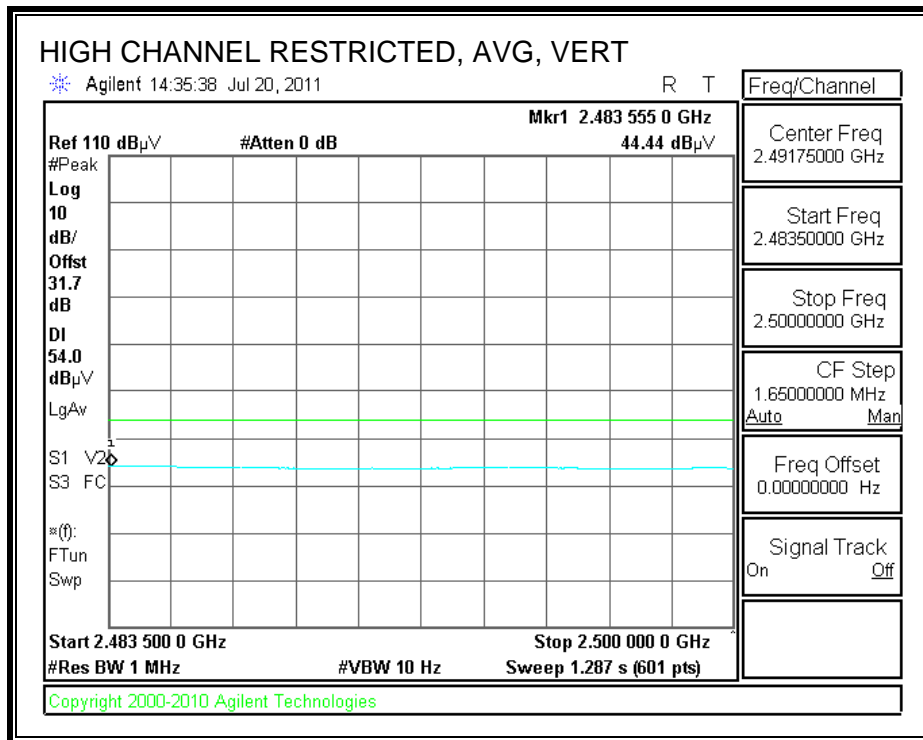
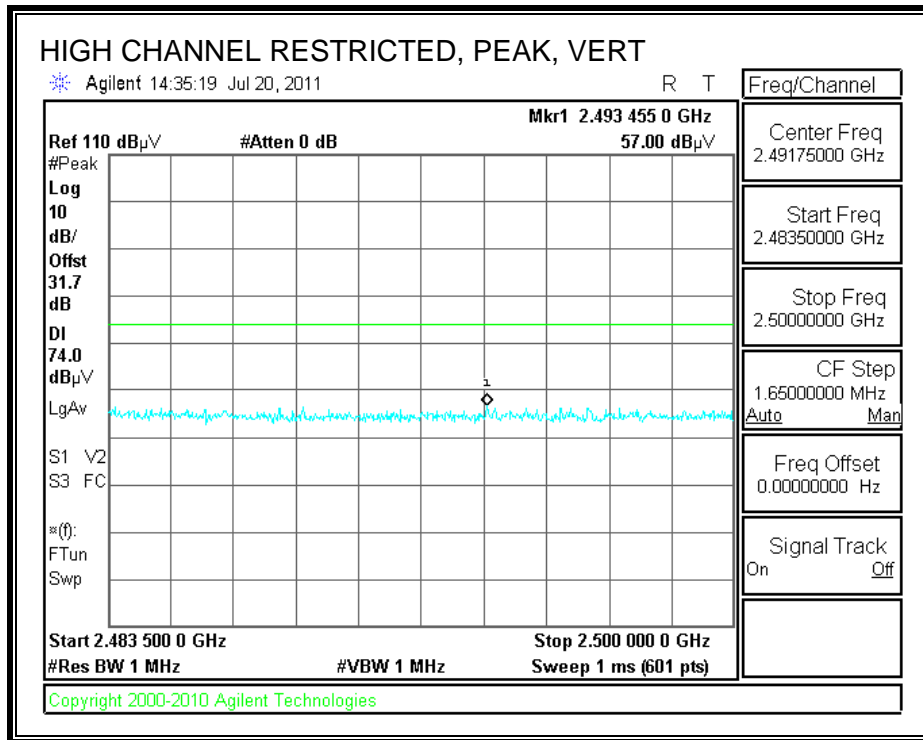

**HARMONICS AND SPURIOUS EMISSIONS**

High Frequency Measurement													Notes
Compliance Certification Services, Fremont 5m Chamber													
Test Engr:		Vien Tran											
Date:		07/21/11											
Project #:		11U13739											
Company:		LG Electronics Inc.,											
Test Target:		FCC Class B											
Mode Oper:		Tx 11g Mode											
f	Measurement Frequency		Amp	Preamp Gain		Average Field Strength Limit							
Dist	Distance to Antenna		D Corr	Distance Correct to 3 meters		Peak Field Strength Limit							
Read	Analyzer Reading		Avg	Average Field Strength @ 3 m		Margin vs. Average Limit							
AF	Antenna Factor		Peak	Calculated Peak Field Strength		Margin vs. Peak Limit							
CL	Cable Loss		HPF	High Pass Filter									
f	Dist	Read	AF	CL	Amp	D Corr	Fltr	Corr.	Limit	Margin	Ant. Pol.	Det.	Notes
GHz	(m)	dBuV	dB/m	dB	dB	dB	dB	dBuV/m	dBuV/m	dB	V/H	P/A/QP	
<b>LOW CHANNEL, 2412MHz</b>													
4.824	3.0	42.3	32.7	5.8	-34.8	0.0	0.0	45.9	74.0	-28.1	H	P	
4.824	3.0	27.6	32.7	5.8	-34.8	0.0	0.0	31.2	54.0	-22.8	H	A	
4.824	3.0	40.6	32.7	5.8	-34.8	0.0	0.0	44.3	74.0	-29.7	V	P	
4.824	3.0	27.3	32.7	5.8	-34.8	0.0	0.0	31.0	54.0	-23.0	V	A	
<b>MID CHANNEL, 2437MHz</b>													
4.874	3.0	39.1	32.7	5.8	-34.8	0.0	0.0	42.8	74.0	-31.2	V	P	
4.874	3.0	26.8	32.7	5.8	-34.8	0.0	0.0	30.5	54.0	-23.5	V	A	
7.311	3.0	36.9	35.5	7.3	-34.1	0.0	0.0	45.5	74.0	-28.5	V	P	
7.311	3.0	24.1	35.5	7.3	-34.1	0.0	0.0	32.7	54.0	-21.3	V	A	
4.874	3.0	41.6	32.7	5.8	-34.8	0.0	0.0	45.4	74.0	-28.6	H	P	
4.874	3.0	28.1	32.7	5.8	-34.8	0.0	0.0	31.8	54.0	-22.2	H	A	
7.311	3.0	35.7	35.5	7.3	-34.1	0.0	0.0	44.3	74.0	-29.7	H	P	
7.311	3.0	22.8	35.5	7.3	-34.1	0.0	0.0	31.4	54.0	-22.6	H	A	
<b>HIGH CHANNEL, 2462MHz</b>													
4.924	3.0	39.7	32.7	5.9	-34.8	0.0	0.0	43.5	74.0	-30.5	V	P	
4.924	3.0	27.5	32.7	5.9	-34.8	0.0	0.0	31.3	54.0	-22.7	V	A	
7.386	3.0	37.4	35.6	7.3	-34.1	0.0	0.0	46.2	74.0	-27.8	V	P	
7.386	3.0	24.5	35.6	7.3	-34.1	0.0	0.0	33.3	54.0	-20.7	V	A	
4.924	3.0	38.8	32.7	5.9	-34.8	0.0	0.0	42.6	74.0	-31.4	H	P	
4.924	3.0	26.0	32.7	5.9	-34.8	0.0	0.0	29.8	54.0	-24.2	H	A	
7.386	3.0	35.4	35.6	7.3	-34.1	0.0	0.0	44.2	74.0	-29.8	H	P	
7.386	3.0	23.5	35.6	7.3	-34.1	0.0	0.0	32.2	54.0	-21.8	H	A	
Rev. 4.1.2.7													
Note: No other emissions were detected above the system noise floor.													



### 7.2.3. 802.11n HT20 SISO MODE IN THE 2.4 GHz BAND

#### RESTRICTED BANDEDGE (LOW CHANNEL, HORIZONTAL)

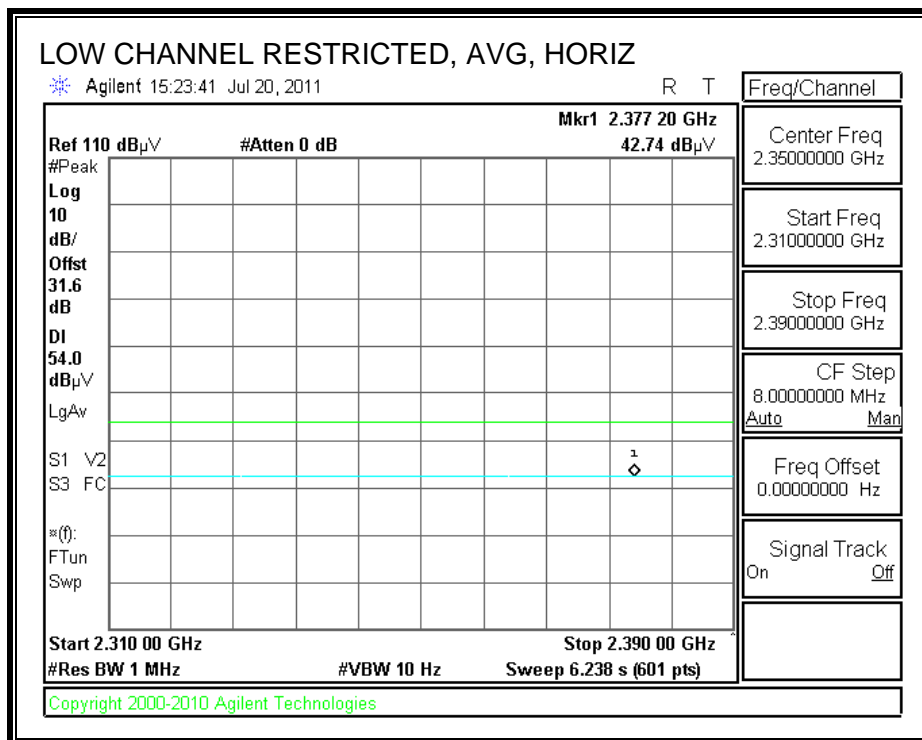
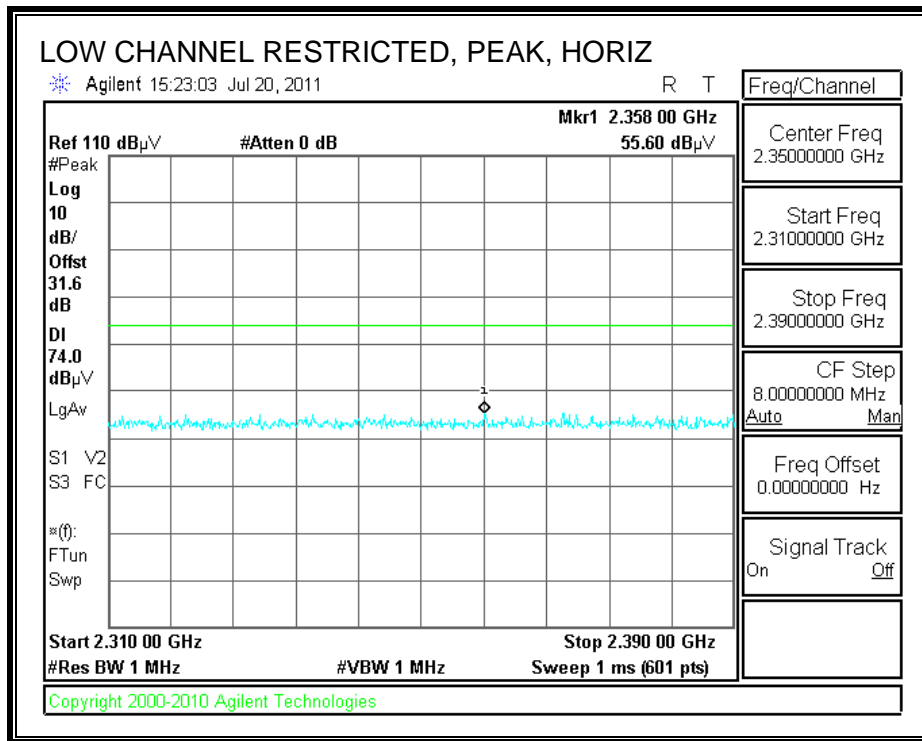

**RESTRICTED BANDEDGE (LOW CHANNEL, VERTICAL)**

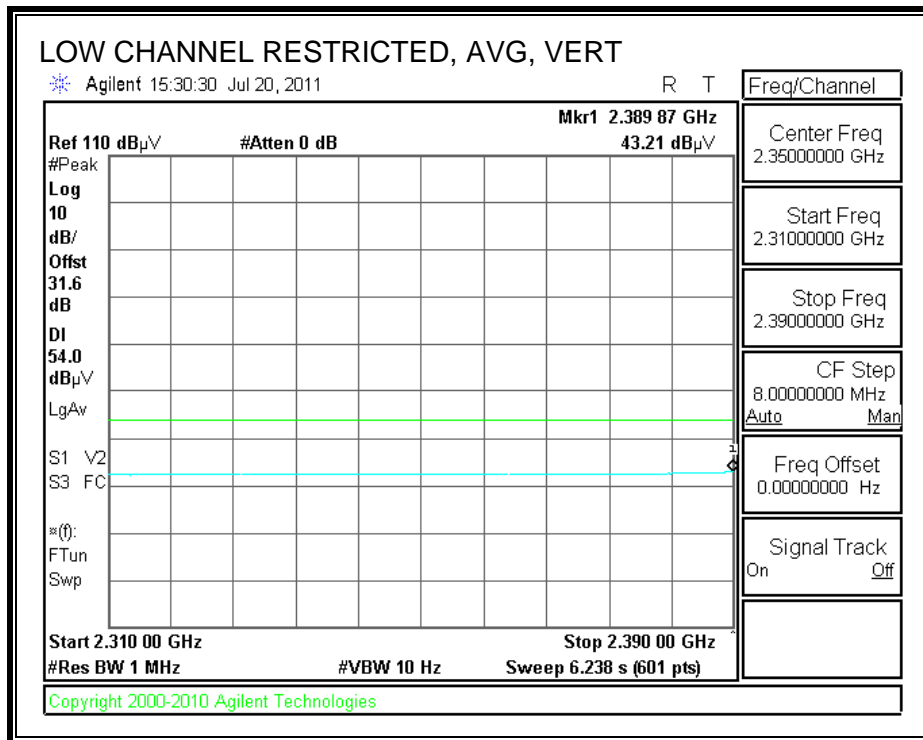
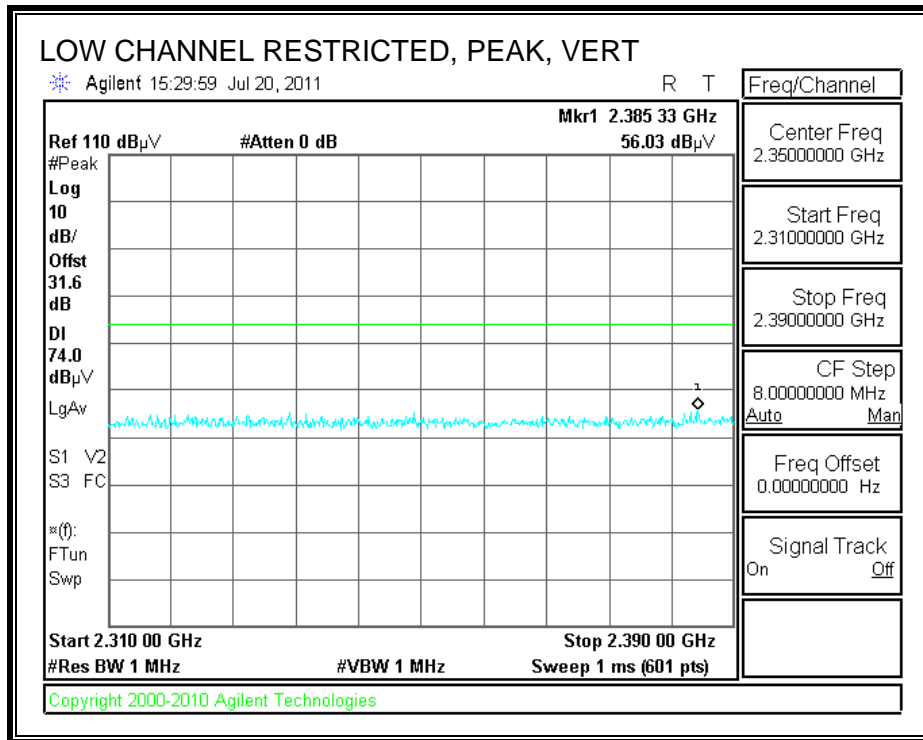

**RESTRICTED BANDEDGE (HIGH CHANNEL, HORIZONTAL)**

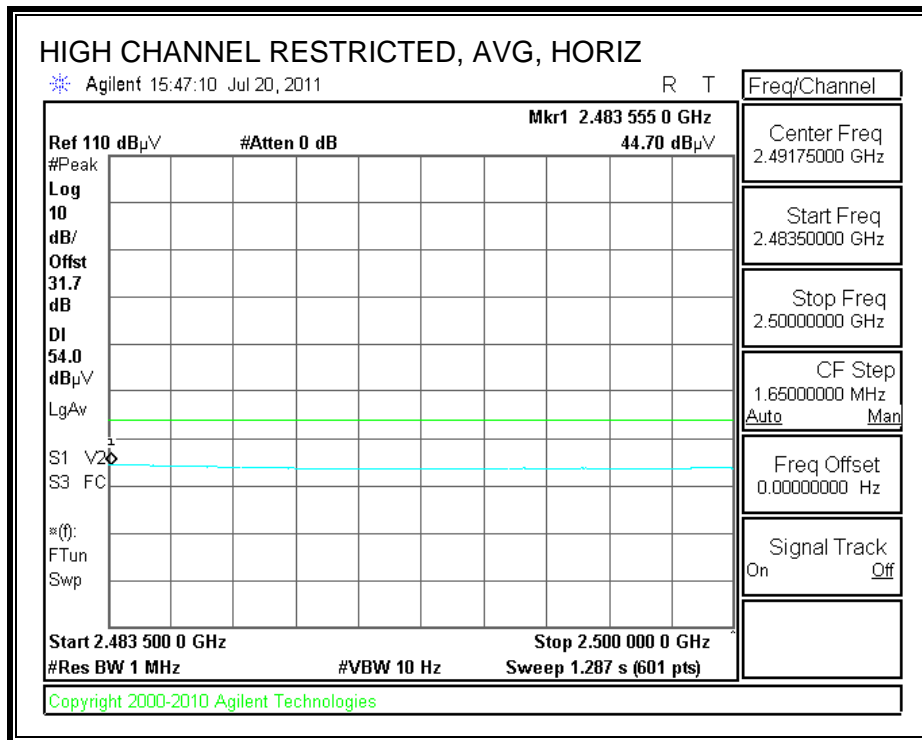
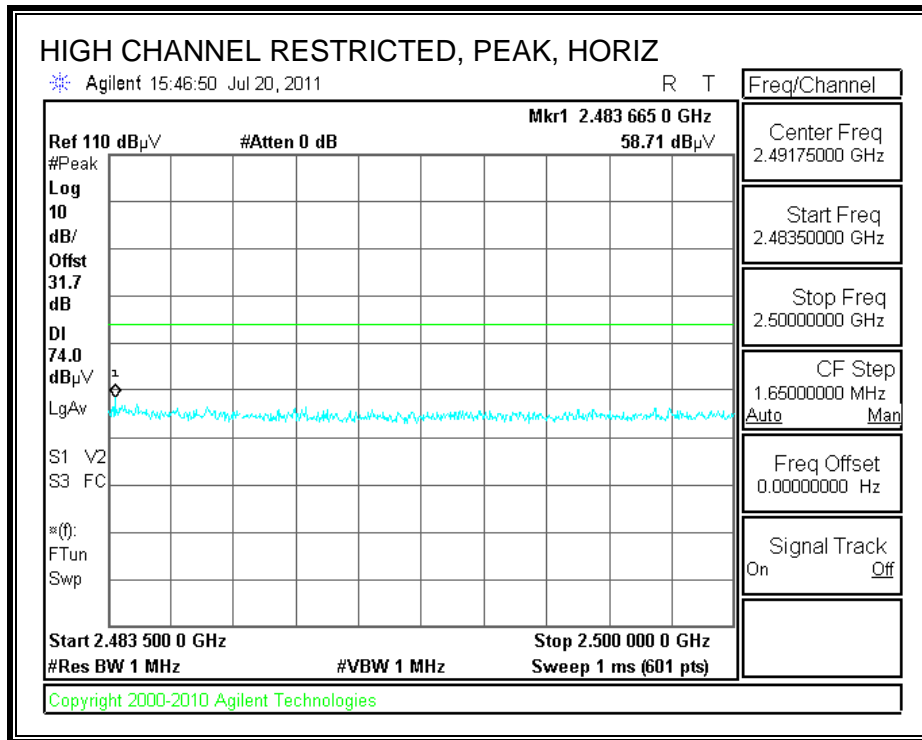

**RESTRICTED BANDEDGE (HIGH CHANNEL, VERTICAL)**

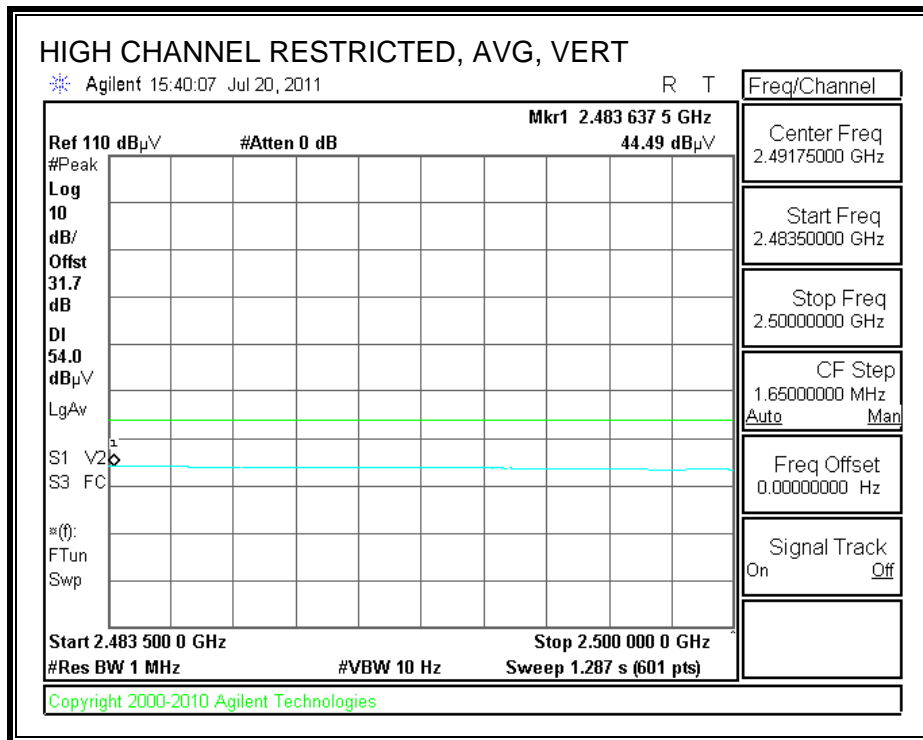
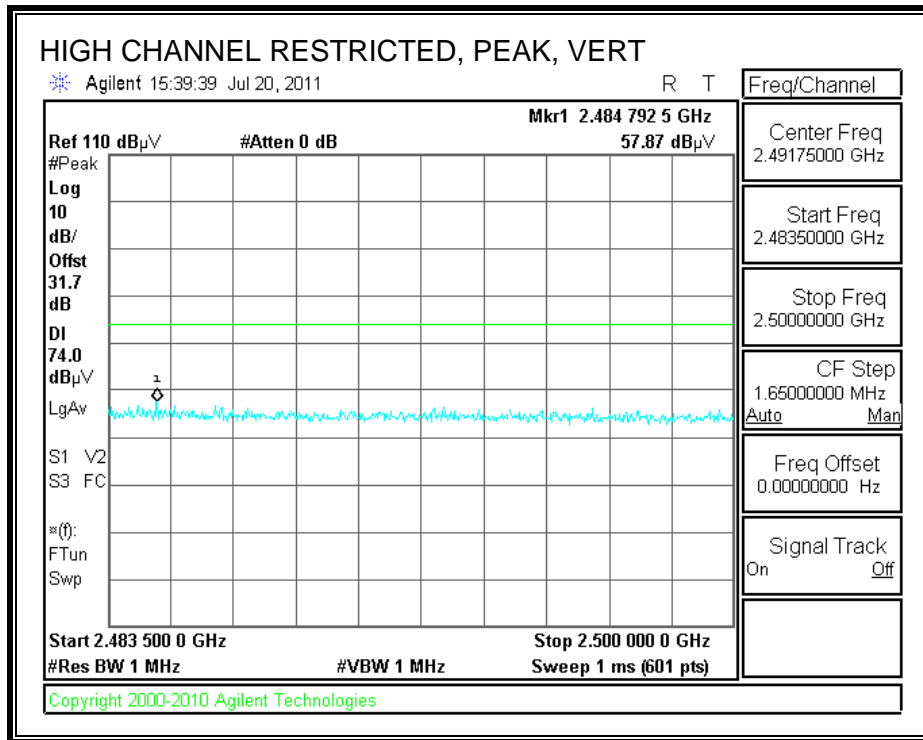

**HARMONICS AND SPURIOUS EMISSIONS**

High Frequency Measurement													
Compliance Certification Services, Fremont 5m Chamber													
Test Engr:		Vien Tran											
Date:		07/20/11											
Project #:		11U13739											
Company:		LG Electronics Inc.,											
Test Target:		FCC Class B											
Mode Oper:		Tx 11n HT20 SISO											
f	Measurement Frequency			Amp	Preamp Gain			Average Field Strength Limit					
Dist	Distance to Antenna			D Corr	Distance Correct to 3 meters			Peak Field Strength Limit					
Read	Analyzer Reading			Avg	Average Field Strength @ 3 m			Margin vs. Average Limit					
AF	Antenna Factor			Peak	Calculated Peak Field Strength			Margin vs. Peak Limit					
CL	Cable Loss			HPF	High Pass Filter								
f	Dist	Read	AF	CL	Amp	D Corr	Fltr	Corr.	Limit	Margin	Ant. Pol.	Det.	Notes
GHz	(m)	dBuV	dB/m	dB	dB	dB	dB	dBuV/m	dBuV/m	dB	V/H	P/A/QP	
<b>LOW CHANNEL, 2412MHz</b>													
4.824	3.0	41.4	32.7	5.8	-34.8	0.0	0.0	45.0	74.0	-29.0	V	P	
4.824	3.0	27.8	32.7	5.8	-34.8	0.0	0.0	31.4	54.0	-22.6	V	A	
4.824	3.0	42.7	32.7	5.8	-34.8	0.0	0.0	46.4	74.0	-27.6	H	P	
4.824	3.0	28.5	32.7	5.8	-34.8	0.0	0.0	32.1	54.0	-21.9	H	A	
<b>MID CHANNEL, 2437MHz</b>													
4.874	3.0	43.5	32.7	5.8	-34.8	0.0	0.0	47.2	74.0	-26.8	V	P	
4.874	3.0	30.2	32.7	5.8	-34.8	0.0	0.0	33.9	54.0	-20.1	V	A	
7.311	3.0	37.3	35.5	7.3	-34.1	0.0	0.0	46.0	74.0	-28.0	V	P	
7.311	3.0	23.6	35.5	7.3	-34.1	0.0	0.0	32.2	54.0	-21.8	V	A	
4.874	3.0	42.5	32.7	5.8	-34.8	0.0	0.0	46.2	74.0	-27.8	H	P	
4.874	3.0	28.2	32.7	5.8	-34.8	0.0	0.0	31.9	54.0	-22.1	H	A	
7.311	3.0	35.1	35.5	7.3	-34.1	0.0	0.0	43.7	74.0	-30.3	H	P	
7.311	3.0	22.9	35.5	7.3	-34.1	0.0	0.0	31.5	54.0	-22.5	H	A	
<b>HIGH CHANNEL, 2462MHz</b>													
4.924	3.0	44.7	32.7	5.9	-34.8	0.0	0.0	48.5	74.0	-25.5	V	P	
4.924	3.0	30.6	32.7	5.9	-34.8	0.0	0.0	34.4	54.0	-19.6	V	A	
7.386	3.0	37.7	35.6	7.3	-34.1	0.0	0.0	46.5	74.0	-27.5	V	P	
7.386	3.0	24.5	35.6	7.3	-34.1	0.0	0.0	33.3	54.0	-20.7	V	A	
4.924	3.0	40.6	32.7	5.9	-34.8	0.0	0.0	44.4	74.0	-29.6	H	P	
4.924	3.0	28.0	32.7	5.9	-34.8	0.0	0.0	31.8	54.0	-22.2	H	A	
7.386	3.0	36.2	35.6	7.3	-34.1	0.0	0.0	45.0	74.0	-29.0	H	P	
7.386	3.0	23.8	35.6	7.3	-34.1	0.0	0.0	32.6	54.0	-21.4	H	A	
Rev. 4.1.2.7													
Note: No other emissions were detected above the system noise floor.													

### 7.1. WORST-CASE BELOW 1 GHz

#### SPURIOUS EMISSIONS 30 TO 1000 MHz (WORST-CASE CONFIGURATION, HORIZONTAL)

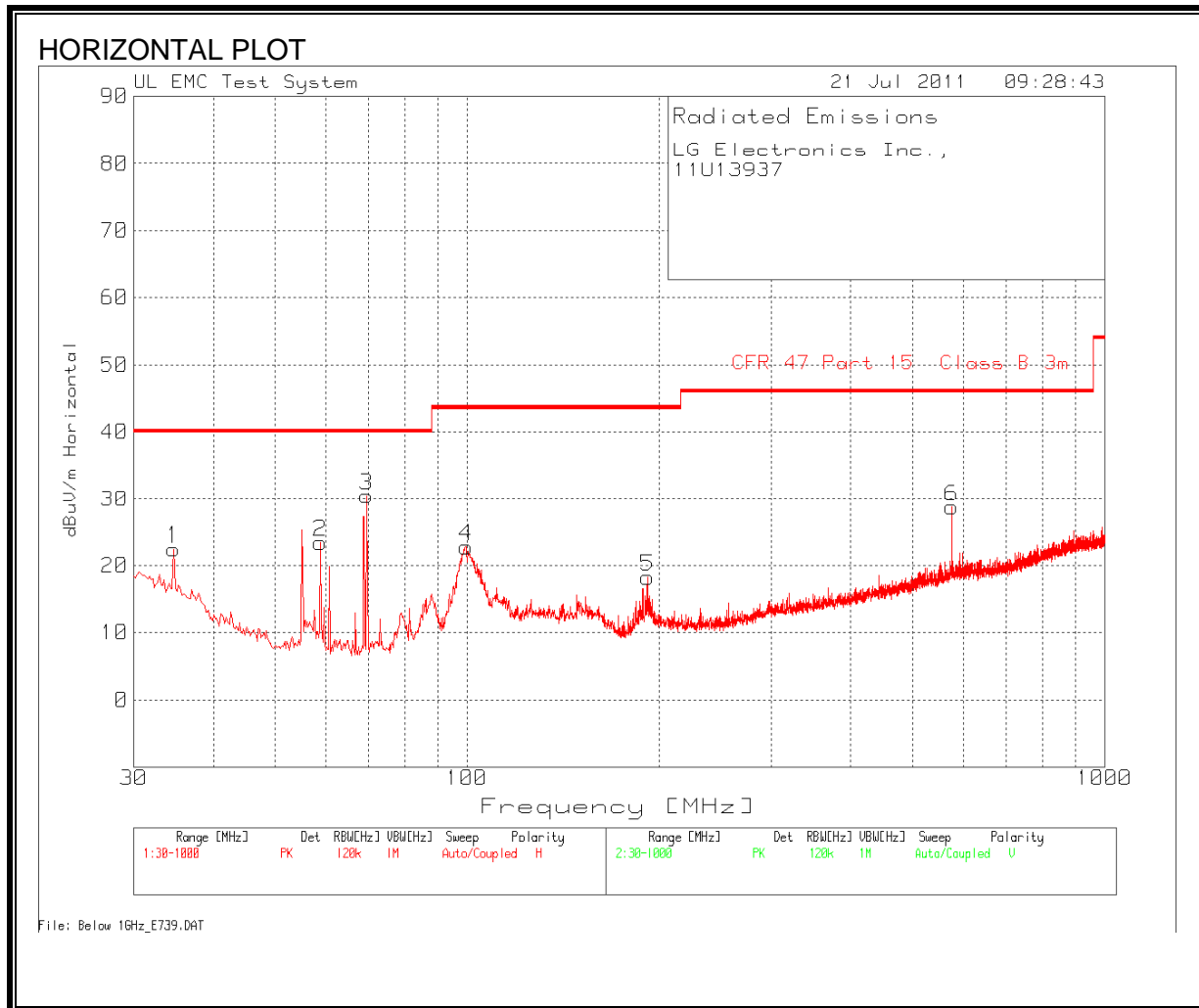

**SPURIOUS EMISSIONS 30 TO 1000 MHz (WORST-CASE CONFIGURATION, VERTICAL)**

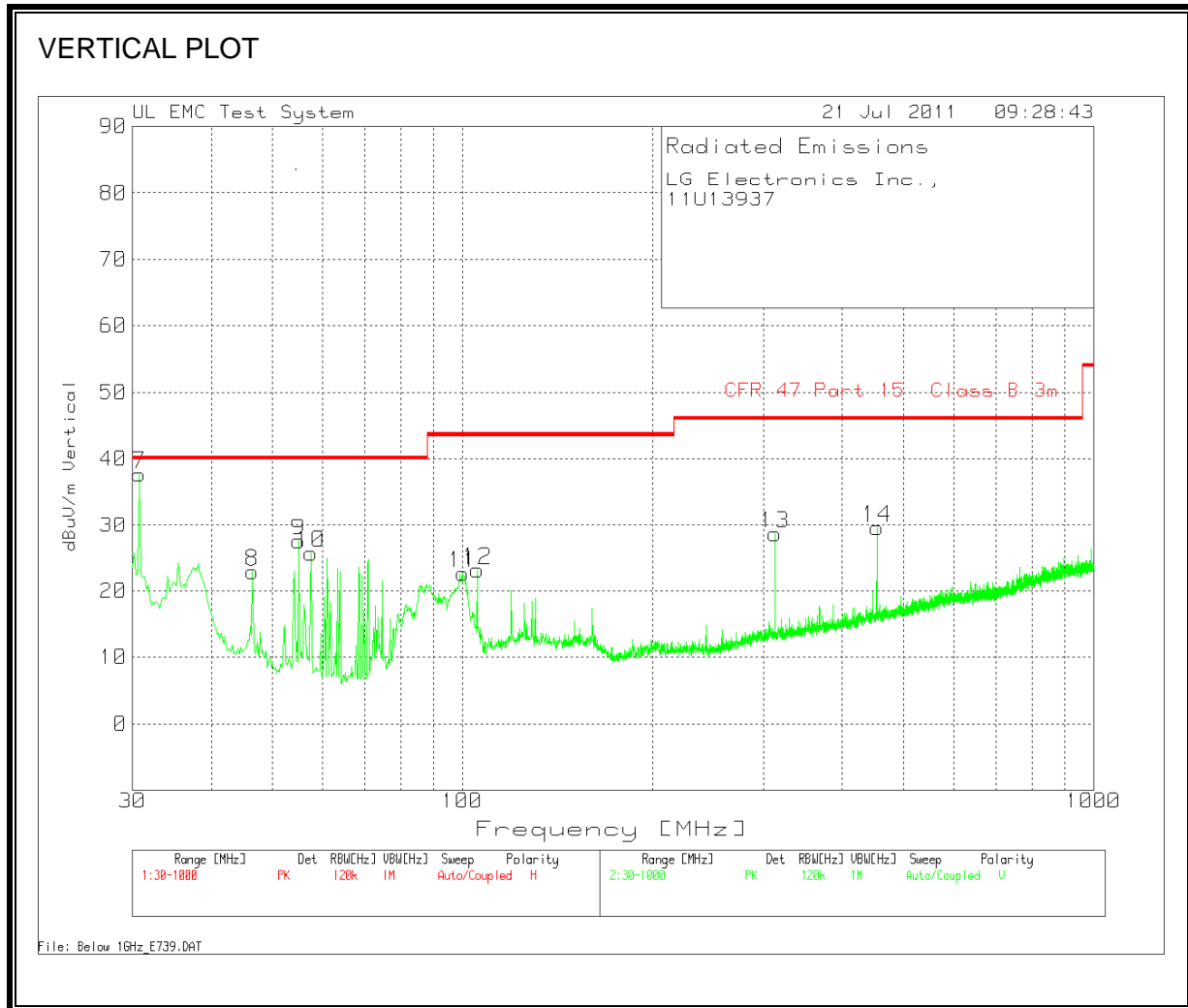

**HORIZONTAL AND VERTICAL DATA**

LG Electronics Inc.,  
 Project Number: 11U13937  
 Model: E739

Test Engineer: Vien Tran  
 Date: July 21, 2011

**30 - 1000MHz - HORIZONTAL**

Test Frequency	Meter Reading	Detector	3m below 1GHz Cable.TXT [dB]	3m T15 PreAmp below 1GHz.TXT [dB]	3m Bilog T185 below 1GHz.TXT [dB]	dBuV/m	CFR 47 Part 15 Class B 3m	Margin	Height [cm]	Polarity
34.6523	32.42	PK	0.6	-28.3	17.7	22.42	40.0	-17.58	175	Horz
58.8829	42.72	PK	0.8	-28.2	8.1	23.42	40.0	-16.58	251	Horz
69.5444	49.43	PK	0.9	-28.1	8.2	30.43	40.0	-9.57	251	Horz
99.5903	40.55	PK	1.0	-28.1	9.3	22.75	43.5	-20.75	175	Horz
191.8605	33.15	PK	1.4	-27.7	11.4	18.25	43.5	-25.25	175	Horz
575.8673	36.53	PK	2.5	-28.4	18.1	28.73	46.0	-17.27	175	Horz

**30 - 1000MHz - VERTICAL**

Test Frequency	Meter Reading	Detector	3m below 1GHz Cable.TXT [dB]	3m T15 PreAmp below 1GHz.TXT [dB]	3m Bilog T185 below 1GHz.TXT [dB]	dBuV/m	CFR 47 Part 15 Class B 3m	Margin	Height [cm]	Polarity
30.7754	45.77	PK	0.6	-28.3	19.6	37.67	40.0	-2.33	176	Vert
30.7754	38.89	QP	0.6	-28.3	19.6	30.79	40.0	-9.21	176	Vert
46.48	39.35	PK	0.7	-28.2	11.0	22.85	40.0	-17.15	251	Vert
55.006	46.36	PK	0.8	-28.2	8.6	27.56	40.0	-12.44	251	Vert
57.526	44.79	PK	0.8	-28.2	8.3	25.69	40.0	-14.31	99	Vert
100.1719	40.22	PK	1.0	-28.0	9.4	22.62	43.5	-20.88	176	Vert
105.5995	39.61	PK	1.0	-28.0	10.5	23.11	43.5	-20.39	99	Vert
313.0136	40.43	PK	1.8	-27.3	13.7	28.63	46.0	-17.37	176	Vert
454.1327	39.55	PK	2.2	-28.2	16.0	29.55	46.0	-16.45	99	Vert

PK - Peak detector  
 QP - Quasi-Peak detector  
 LnAv - Linear Average detector  
 LgAv - Log Average detector  
 Av - Average detector  
 CAV - CISPR Average detector  
 RMS - RMS detection  
 CRMS - CISPR RMS detection  
 File: RE 30-1000 MHz 3m FCC Class B Full Scan.TST



## 8. AC POWER LINE CONDUCTED EMISSIONS

### LIMITS

FCC §15.207 (a)

RSS-Gen 7.2.2

Frequency of Emission (MHz)	Conducted Limit (dBuV)	
	Quasi-peak	Average
0.15-0.5	66 to 56*	56 to 46*
0.5-5	56	46
5-30	60	50

\*Decreases with the logarithm of the frequency.

### TEST PROCEDURE

ANSI C63.4

**RESULTS**

**6 WORST EMISSIONS**

LG Electronics Inc.,						Test Engineer: Vien Tran			
Project Number: 11U13937						Date: July 21, 2011			
Model: E739									
Line-L1 .15 - 30MHz									
Test Frequency	Meter Reading	Detector	LISN [dB]	Conducted Emission Cable [dB]	dB[uVolts]	Class B QP Limit	Margin	Class B Avg Limit	Margin
0.159	44.25	PK	0	0	44.25	65.50	-21.25	55.50	-11.25
0.159	31.52	Av	0	0	31.52	65.50	-33.98	55.50	-23.98
3.174	44.64	PK	0	0	44.64	56.00	-11.36	46.00	-1.36
3.174	32.92	Av	0	0	32.92	56.00	-23.08	46.00	-13.08
13.6815	36.18	PK	0	0	36.18	60.00	-23.82	50.00	-13.82
13.6815	22.15	Av	0	0	22.15	60.00	-37.85	50.00	-27.85
Line-L2 .15 - 30MHz									
Test Frequency	Meter Reading	Detector	LISN [dB]	Conducted Emission Cable [dB]	dB[uVolts]	Class B QP Limit	Margin	Class B Avg Limit	Margin
0.1725	43.85	PK	0	0	43.85	64.80	-20.95	54.80	-10.95
0.1725	24.81	Av	0	0	24.81	64.80	-39.99	54.80	-29.99
2.8995	39.04	PK	0	0	39.04	56.00	-16.96	46.00	-6.96
2.8995	24.35	Av	0	0	24.35	56.00	-31.65	46.00	-21.65
18.2445	35.45	PK	0	0	35.45	60.00	-24.55	50.00	-14.55
18.2445	22.66	Av	0	0	22.66	60.00	-37.34	50.00	-27.34
PK - Peak detector									
QP - Quasi-Peak detector									
LnAv - Linear Average detector									
LgAv - Log Average detector									
Av - Average detector									
CAV - CISPR Average detector									
RMS - RMS detection									
CRMS - CISPR RMS detection									

**LINE 1 RESULTS**

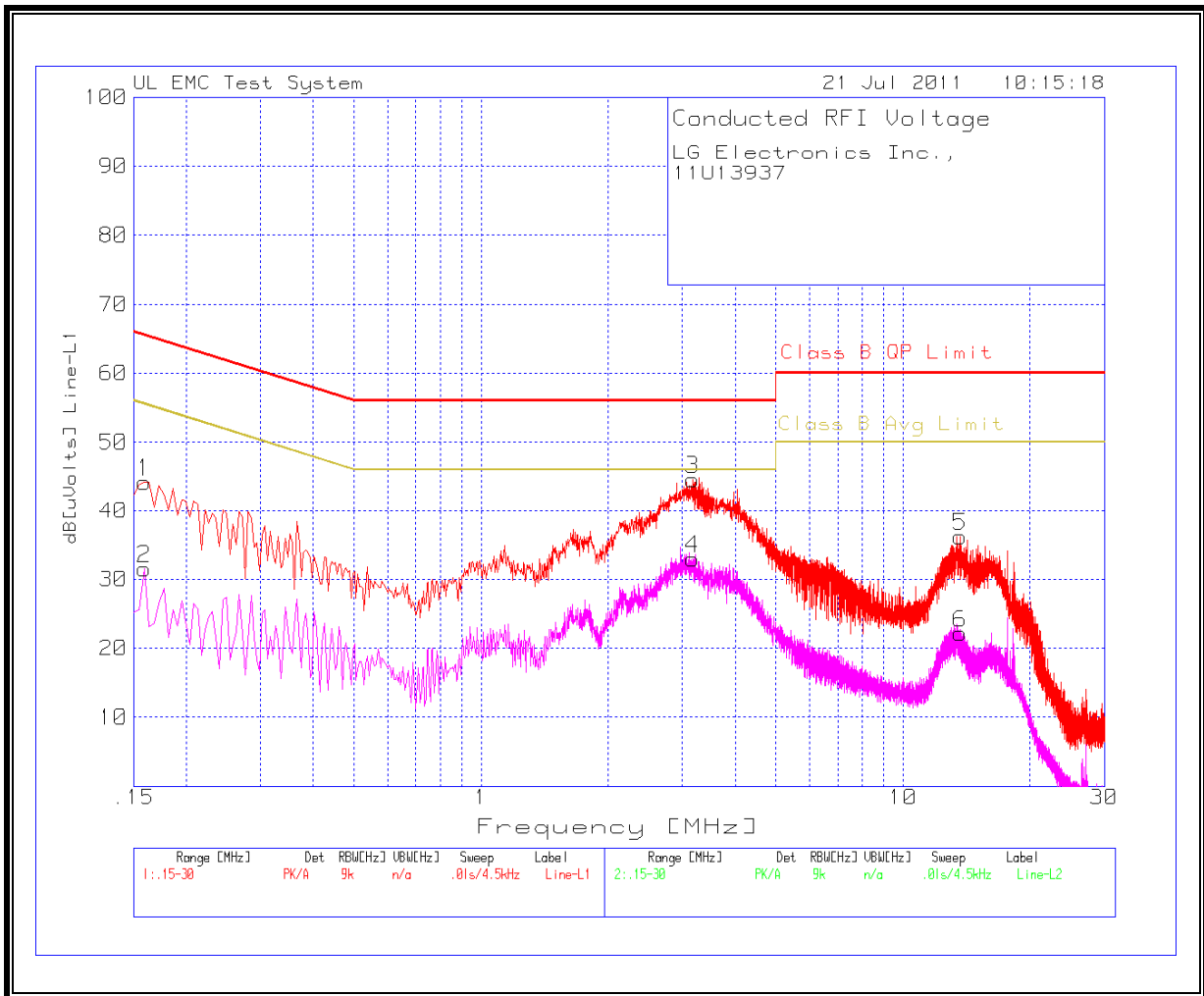

**LINE 2 RESULTS**

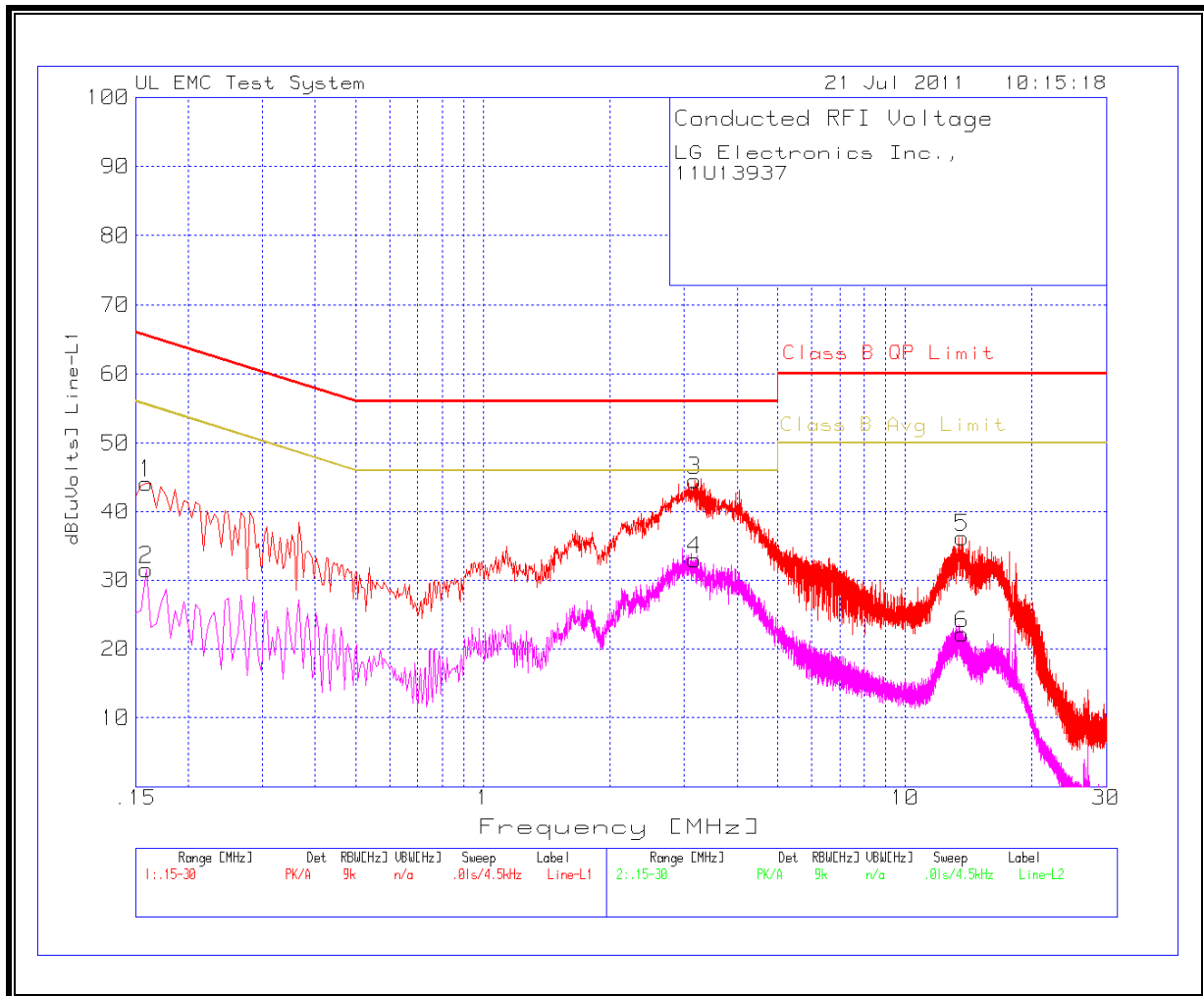

## 9. MAXIMUM PERMISSIBLE EXPOSURE

### FCC RULES

§1.1310 The criteria listed in Table 1 shall be used to evaluate the environmental impact of human exposure to radio-frequency (RF) radiation as specified in §1.1307(b), except in the case of portable devices which shall be evaluated according to the provisions of §2.1093 of this chapter.

TABLE 1—LIMITS FOR MAXIMUM PERMISSIBLE EXPOSURE (MPE)

Frequency range (MHz)	Electric field strength (V/m)	Magnetic field strength (A/m)	Power density (mW/cm <sup>2</sup> )	Averaging time (minutes)
(A) Limits for Occupational/Controlled Exposures				
0.3–3.0 .....	614	1.63	*(100)	6
3.0–30 .....	1842/f	4.89/f	*(900/f <sup>2</sup> )	6
30–300 .....	61.4	0.163	1.0	6
300–1500 .....			f/300	6
1500–100,000 .....			5	6
(B) Limits for General Population/Uncontrolled Exposure				
0.3–1.34 .....	614	1.63	*(100)	30
1.34–30 .....	824/f	2.19/f	*(180/f <sup>2</sup> )	30

TABLE 1—LIMITS FOR MAXIMUM PERMISSIBLE EXPOSURE (MPE)—Continued

Frequency range (MHz)	Electric field strength (V/m)	Magnetic field strength (A/m)	Power density (mW/cm <sup>2</sup> )	Averaging time (minutes)
30–300 .....	27.5	0.073	0.2	30
300–1500 .....			f/1500	30
1500–100,000 .....			1.0	30

f = frequency in MHz

\* = Plane-wave equivalent power density

NOTE 1 TO TABLE 1: Occupational/controlled limits apply in situations in which persons are exposed as a consequence of their employment provided those persons are fully aware of the potential for exposure and can exercise control over their exposure. Limits for occupational/controlled exposure also apply in situations when an individual is transient through a location where occupational/controlled limits apply provided he or she is made aware of the potential for exposure.

NOTE 2 TO TABLE 1: General population/uncontrolled exposures apply in situations in which the general public may be exposed, or in which persons that are exposed as a consequence of their employment may not be fully aware of the potential for exposure or can not exercise control over their exposure.

**Table 5**  
**Exposure Limits for Persons Not Classified As RF and Microwave Exposed Workers (Including the General Public)**

1 Frequency (MHz)	2 Electric Field Strength; rms (V/m)	3 Magnetic Field Strength; rms (A/m)	4 Power Density (W/m <sup>2</sup> )	5 Averaging Time (min)
0.003–1	280	2.19		6
1–10	280/ <i>f</i>	2.19/ <i>f</i>		6
10–30	28	2.19/ <i>f</i>		6
30–300	28	0.073	2*	6
300–1 500	1.585 <i>f</i> <sup>0.5</sup>	0.0042 <i>f</i> <sup>0.5</sup>	<i>f</i> /150	6
1 500–15 000	61.4	0.163	10	6
15 000–150 000	61.4	0.163	10	616 000 / <i>f</i> <sup>1.2</sup>
150 000–300 000	0.158 <i>f</i> <sup>0.5</sup>	4.21 x 10 <sup>-4</sup> <i>f</i> <sup>0.5</sup>	6.67 x 10 <sup>-5</sup> <i>f</i>	616 000 / <i>f</i> <sup>1.2</sup>

\* Power density limit is applicable at frequencies greater than 100 MHz.

- Notes:**
1. Frequency, *f*, is in MHz.
  2. A power density of 10 W/m<sup>2</sup> is equivalent to 1 mW/cm<sup>2</sup>.
  3. A magnetic field strength of 1 A/m corresponds to 1.257 microtesla (μT) or 12.57 milligauss (mG).

**EQUATIONS**

Power density is given by:

$$S = \text{EIRP} / (4 * \text{Pi} * D^2)$$

where

S = Power density in W/m<sup>2</sup>

EIRP = Equivalent Isotropic Radiated Power in W

D = Separation distance in m

Power density in units of W/m<sup>2</sup> is converted to units of mW/cm<sup>2</sup> by dividing by 10.

Distance is given by:

$$D = \text{SQRT} (\text{EIRP} / (4 * \text{Pi} * S))$$

where

D = Separation distance in m

EIRP = Equivalent Isotropic Radiated Power in W

S = Power density in W/m<sup>2</sup>

For multiple chain devices, and collocated transmitters operating simultaneously in frequency bands where the limit is identical, the total power density is calculated using the total EIRP obtained by summing the Power \* Gain product (in linear units) of each transmitter.

$$\text{Total EIRP} = (P_1 * G_1) + (P_2 * G_2) + \dots + (P_n * G_n)$$

where

P<sub>x</sub> = Power of transmitter x

G<sub>x</sub> = Numeric gain of antenna x

For multiple collocated transmitters operating simultaneously in frequency bands where different limits apply, a fraction of the exposure limit is established for each band, such that the sum of the fractions is less than or equal to one.

In the table(s) below, Power and Gain are entered in units of dBm and dBi respectively and conversions to linear forms are used for the calculations.

**LIMITS**

For mobile radio equipment operating in the cellular phone band, the lowest power density limit is calculated using the lowest frequency, as 824 MHz / 1500 = 0.55 mW/cm<sup>2</sup> (FCC) and 824 MHz / 150 = 5.5 W/m<sup>2</sup> (IC).

From FCC §1.1310 Table 1 (B), the maximum value of S = 1.0 mW/cm<sup>2</sup>

From IC Safety Code 6, Section 2.2 Table 5 Column 4, S = 10 W/m<sup>2</sup>

**RESULTS**

Single Chain and non-collocated transmitters							
Band	Mode	Separation Distance (m)	Output AV Power (dBm)	Antenna Gain (dBi)	EIRP (dBm)	EIRP (W)	FCC Power Density (mW/cm <sup>2</sup> )
2.4 GHz	WLAN	0.20	15.80	-2.19	13.61	0.02	0.005