

TEST REPORT

of

FCC Part 15 Subpart C §15.225

FCC ID : ZNFDM01G

Equipment Under Test : Cellular/PCS GSM/GPRS/EDGE/WCDMA/HSDPA/HSUPA Smart Phone
Model Name : DM-01G
Applicant : LG Electronics MobileComm U.S.A., Inc.
Manufacturer : LG Electronics MobileComm U.S.A., Inc.
Date of Test(s) : 2015.02.12 ~ 2015.03.16
Date of Issue : 2015.03.16

In the configuration tested, the EUT complied with the standards specified above.

Tested By:



Date:

2015.03.16

Youngmin Park

Approved By:



Date:

2015.03.16

Hyunchoe You

The results shown in this test report refer only to the sample(s) tested unless otherwise stated. This test report cannot be reproduced, except in full, without prior written permission of the Company.

INDEX

<u>TABLE OF CONTENTS</u>	Page
1. General Information -----	3
2. AC Power Line Conducted Emissions -----	6
3. Radiated Emissions -----	14
4. Frequency Stability -----	22
5. 20 dB Bandwidth -----	24

The results shown in this test report refer only to the sample(s) tested unless otherwise stated. This test report cannot be reproduced, except in full, without prior written permission of the Company.

1. General Information

1.1. Testing Laboratory

SGS Korea Co., Ltd. (Gunpo Laboratory)

- Wireless Div. 2FL, 10-2, LS-ro 182beon-gil, Gunpo-si, Gyeonggi-do, Korea, 435-837

All SGS services are rendered in accordance with the applicable SGS conditions of service available on request and accessible at <http://www.sgs.com/en/Terms-and-Conditions.aspx>.

Phone No. : + 82 31 688 0901

Fax No. : + 82 31 688 0921

1.2. Details of Applicant

Applicant : LG Electronics MobileComm U.S.A., Inc.

Address : 10101 Old Grove Road, San Diego, CA 92131

Contact Person : An, Hee-Ju

Phone No. : +82 2 2033 1103

1.3. Description of EUT

Kind of Product	Cellular/PCS GSM/GPRS/EDGE/WCDMA/HSDPA/HSUPA Smart Phone
Model Name	DM-01G
Power Supply	DC 3.8 V
Frequency Range	13.56 MHz (NFC)
Modulation Technique	ASK
Number of Channels	1 channel (NFC)
Antenna Type	Internal type

The results shown in this test report refer only to the sample(s) tested unless otherwise stated. This test report cannot be reproduced, except in full, without prior written permission of the Company.

SGS Korea Co., Ltd. (Gunpo Laboratory) 4, LS-ro 182beon-gil, Gunpo-si, Gyeonggi-do, Korea, 435-040 <http://www.sgsgroup.kr>

1.4. Test Equipment List

Equipment	Manufacturer	Model	S/N	Cal. Date	Cal. Interval	Cal. Due
Signal Generator	Agilent	E8257D	MY51501169	Jul. 17, 2014	Annual	Jul. 17, 2015
Spectrum Analyzer	R&S	FSV30	100768	Mar. 27, 2014	Annual	Mar. 27, 2015
High Pass Filter	Mini circuits	NHP-25+	V9741901107	Mar. 21, 2014	Annual	Mar. 21, 2015
DC Power Supply	Agilent	U8002A	MY49030063	Dec. 06, 2014	Annual	Dec. 06, 2015
Temperature Chamber	ESPEC CORP.	PL-1J	15000793	Jun. 25, 2014	Annual	Jun. 25, 2015
Preamplifier	H.P.	8447F	2944A03909	Aug. 27, 2014	Annual	Aug. 27, 2015
Bilog Antenna	SCHWARZBECK MESSELEKTRONIK	VULB9163	396	Jun. 07, 2013	Biennial	Jun. 07, 2015
Loop Antenna	SCHWARZBECK MESSELEKTRONIK	FMZB 1519	1519-039	Jul. 09, 2013	Biennial	Jul. 09, 2015
Test Receiver	R&S	ESU26	100368	Dec. 16, 2014	Annual	Dec. 16, 2015
Test Receiver	R&S	ESCI 7	100911	Dec. 24, 2014	Annual	Dec. 24, 2015
Antenna Master	INN-CO	MM4000	N/A	N/A	N/A	N.C.R.
Turn Table	INN-CO	DS 1200 S	N/A	N/A	N/A	N.C.R.
Anechoic Chamber	SY Corporation	L x W x H (9.6 m x 6.4 m x 6.6 m)	N/A	N/A	N/A	N.C.R.
Two-Line V-Network	R&S	ENV216	100190	Dec. 25, 2014	Annual	Dec. 25, 2015
Shield Room	SY Corporation	L x W x H (6.5 m x 3.5 m x 3.5 m)	N/A	N.C.R.	N/A	N.C.R.

The results shown in this test report refer only to the sample(s) tested unless otherwise stated. This test report cannot be reproduced, except in full, without prior written permission of the Company.

1.5. Summary of Test Results

The EUT has been tested according to the following specifications:

Applied standard : FCC Part15 subpart C		
Standard section	Test item	Result
15.207	AC Power Line Conducted Emissions	Complied
15.225(a)(b)(c)(d) 15.209	Radiated Emissions	Complied
15.225(e)	Frequency Stability	Complied
15.215(c)	20 dB Bandwidth	-

1.6. Sample calculation

Where relevant, the following sample calculation is provided:

1.6.1. Conducted test

Offset value (dB) = Cable loss (dB)

1.6.2. Radiation test

Field strength level (dB μ V/m) = Measured level (dB μ V) + Antenna factor (dB) + Cable loss (dB) - amplifier (dB)

1.7. Test report revision

Revision	Report number	Date of Issue	Description
0	F690501/RF-RTL008479	2015.03.09	Initial
1	F690501/RF-RTL008479-1	2015.03.16	Retested 20 dB Bandwidth and spurious emissions including restricted band

The results shown in this test report refer only to the sample(s) tested unless otherwise stated. This test report cannot be reproduced, except in full, without prior written permission of the Company.

2. AC Power Line Conducted Emissions

2.1. Test Setup

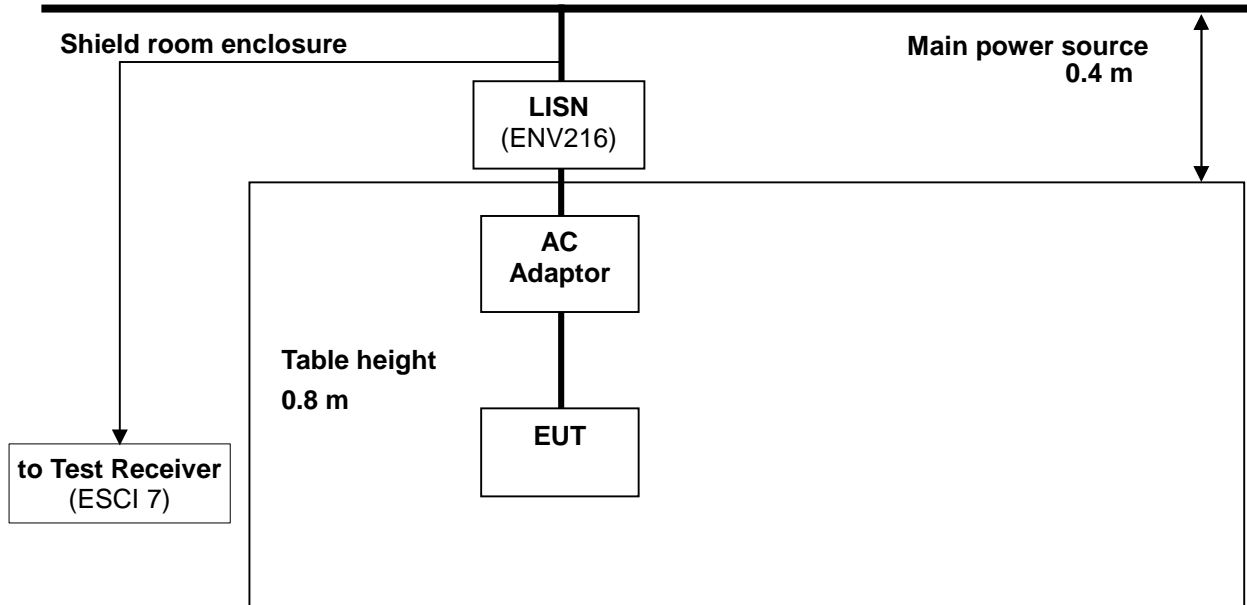

2.2. Limit

According to §15.207(a) for an intentional radiator that is designed to be connected to the public utility (AC) power line, the radio frequency voltage that is conducted back onto the AC power line on any frequency or frequencies, within the band 150 kHz to 30 MHz, shall not exceed the limits in the following table, as measured using a 50 μ H / 50 ohm line impedance stabilization network(LISN).

Compliance with the provision of this paragraph shall on the measurement of the radio frequency voltage between each power line and ground at the power terminal. The lower applies at the boundary between the frequency ranges.

Frequency of Emission (MHz)	Conducted limit (dB μ V)	
	Quasi-peak	Average
0.15 – 0.50	66 - 56*	56 - 46*
0.50 – 5.00	56	46
5.00 – 30.0	60	50

* Decreases with the logarithm of the frequency.

The results shown in this test report refer only to the sample(s) tested unless otherwise stated. This test report cannot be reproduced, except in full, without prior written permission of the Company.

2.3. Test Procedures

All modes were investigated for this test. The full data for the worst case data rate are reported in this section. AC power line conducted emissions from the EUT were measured according to the dictates of ANSI C63.4-2009

1. The test procedure is performed in a 6.5 m × 3.5 m × 3.5 m (L × W × H) shielded room. The EUT along with its peripherals were placed on a 1.0 m (W) × 1.5 m (L) and 0.8 m in height wooden table and the EUT was adjusted to maintain a 0.4 meter space from a vertical reference plane.
2. The EUT was connected to power mains through a line impedance stabilization network (LISN) which provides 50 ohm coupling impedance for measuring instrument and the chassis ground was bounded to the horizontal ground plane of shielded room.
3. The excess power cable between the EUT and the LISN was bundled. All connecting cables of EUT were moved to find the maximum emission.

The results shown in this test report refer only to the sample(s) tested unless otherwise stated. This test report cannot be reproduced, except in full, without prior written permission of the Company.

2.4. Test Results

Ambient temperature : (24 ± 1) °C
 Relative humidity : 47 % R.H.

The following table shows the highest levels of conducted emissions on both phase of Hot and Neutral line.

Frequency range : 0.15 MHz – 30 MHz
 Measured Bandwidth : 9 kHz

-Normal cover

FREQ. (MHz)	LEVEL(dB μ V)		LINE	LIMIT(dB μ V)		MARGIN(dB)	
	Quasi Peak	Average		Quasi Peak	Average	Quasi Peak	Average
0.49	20.10	14.40	N	56.17	46.17	36.07	31.77
1.28	13.90	8.50	N	56.00	46.00	42.10	37.50
6.31	12.60	8.00	N	60.00	50.00	47.40	42.00
10.33	21.30	11.50	N	60.00	50.00	38.70	38.50
11.54	23.60	18.10	N	60.00	50.00	36.40	31.90
19.49	23.00	16.70	N	60.00	50.00	37.00	33.30
0.46	20.10	14.40	H	56.69	46.69	36.59	32.29
1.12	13.90	8.50	H	56.00	46.00	42.10	37.50
1.85	12.60	8.00	H	56.00	46.00	43.40	38.00
6.08	21.30	11.50	H	60.00	50.00	38.70	38.50
11.83	23.60	18.10	H	60.00	50.00	36.40	31.90
15.77	23.00	16.70	H	60.00	50.00	37.00	33.30

Note ;

1. Line (H): Hot, Line (N): Neutral
2. All modes of operation were investigated and the worst-case emissions are reported.
3. The limit for Class B device(s) from 150 kHz to 30 MHz are specified in Section of the Title 47 CFR.
4. Traces shown in plot made using a peak detector and average detector.
5. Deviations to the Specifications: None.

The results shown in this test report refer only to the sample(s) tested unless otherwise stated. This test report cannot be reproduced, except in full, without prior written permission of the Company.

Plots of Conducted Power line

Test mode: (Hot)

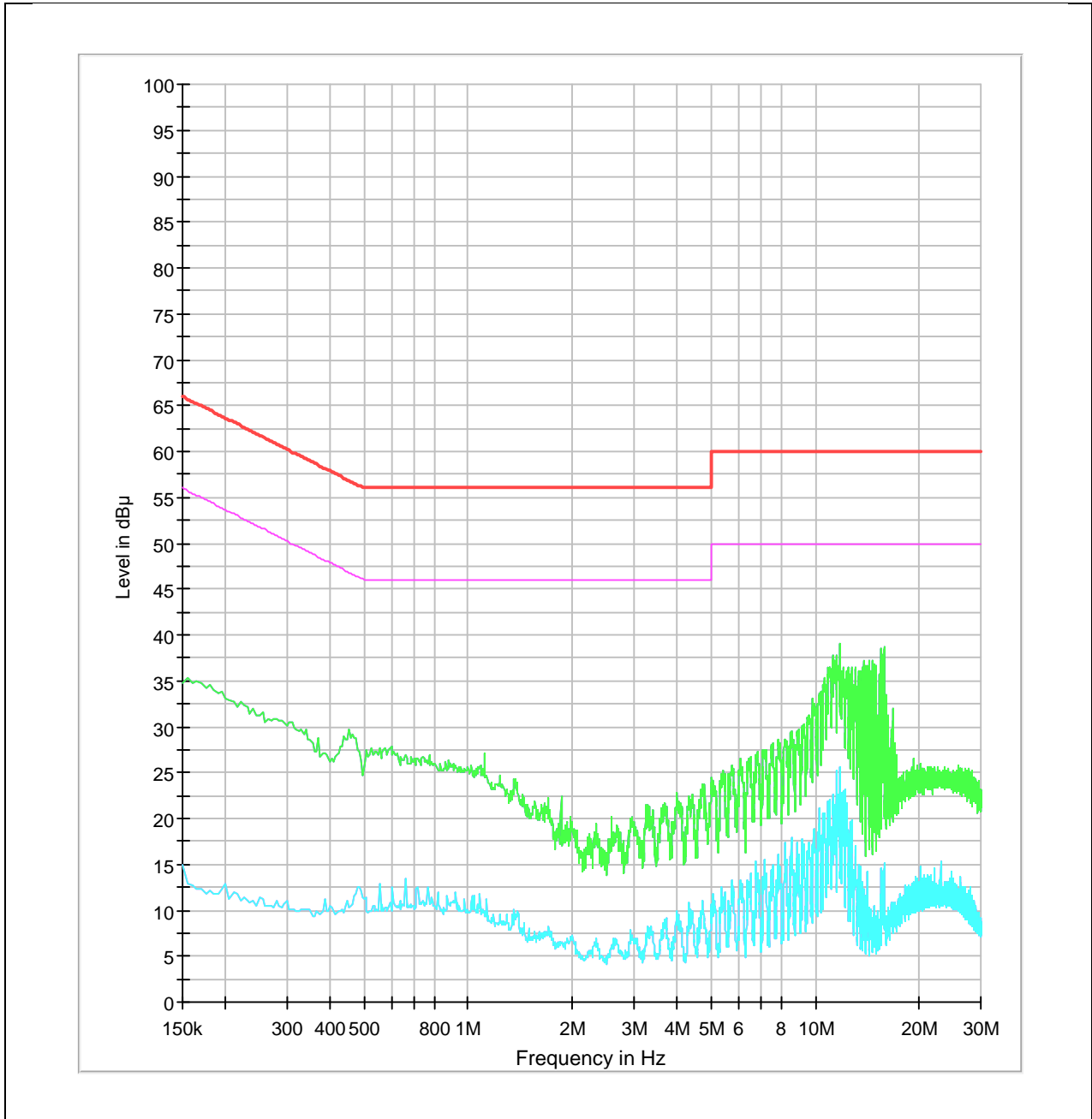

The results shown in this test report refer only to the sample(s) tested unless otherwise stated. This test report cannot be reproduced, except in full, without prior written permission of the Company.

Test mode: (Neutral)

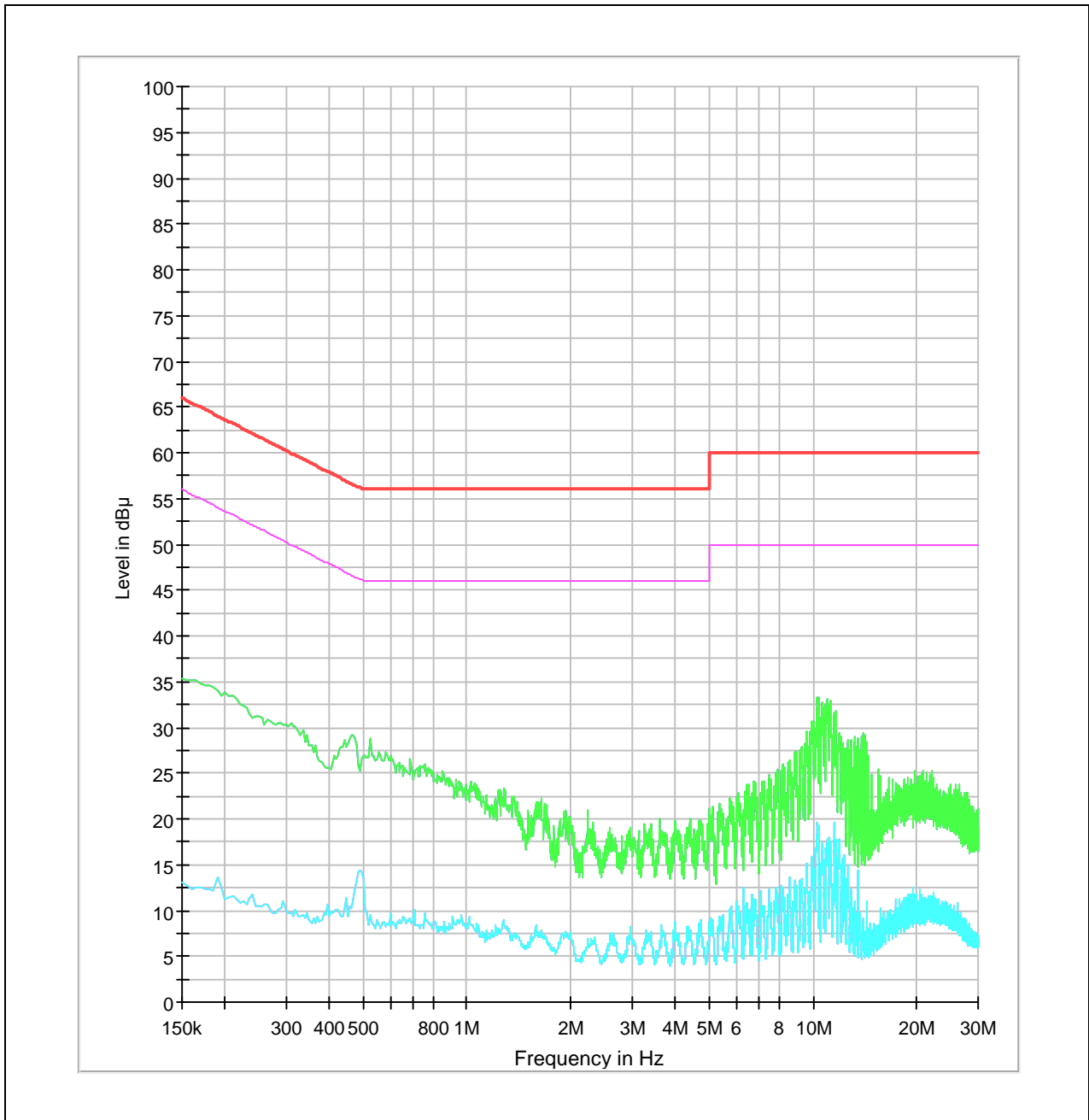

The results shown in this test report refer only to the sample(s) tested unless otherwise stated. This test report cannot be reproduced, except in full, without prior written permission of the Company.

-Quick cover

FREQ. (MHz)	LEVEL(dB μ V)		LINE	LIMIT(dB μ V)		MARGIN(dB)	
	Quasi Peak	Average		Quasi Peak	Average	Quasi Peak	Average
0.48	28.80	19.70	N	56.34	46.34	27.54	26.64
1.04	28.20	19.80	N	56.00	46.00	27.80	26.20
2.35	20.00	14.60	N	56.00	46.00	36.00	31.40
3.56	18.20	13.60	N	56.00	46.00	37.80	32.40
11.95	30.40	23.50	N	60.00	50.00	29.60	26.50
22.35	31.80	19.30	N	60.00	50.00	28.20	30.70
0.49	30.10	21.20	H	56.17	46.17	26.07	24.97
1.10	30.00	20.50	H	56.00	46.00	26.00	25.50
1.84	25.10	16.20	H	56.00	46.00	30.90	29.80
3.58	22.80	15.70	H	56.00	46.00	33.20	30.30
11.60	36.50	27.30	H	60.00	50.00	23.50	22.70
22.85	34.00	21.60	H	60.00	50.00	26.00	28.40

Note ;

1. Line (H): Hot, Line (N): Neutral
2. All modes of operation were investigated and the worst-case emissions are reported.
3. The limit for Class B device(s) from 150 kHz to 30 MHz are specified in Section of the Title 47 CFR.
4. Traces shown in plot made using a peak detector and average detector.
5. Deviations to the Specifications: None.

The results shown in this test report refer only to the sample(s) tested unless otherwise stated. This test report cannot be reproduced, except in full, without prior written permission of the Company.

Plots of Conducted Power line

Test mode : (Hot)

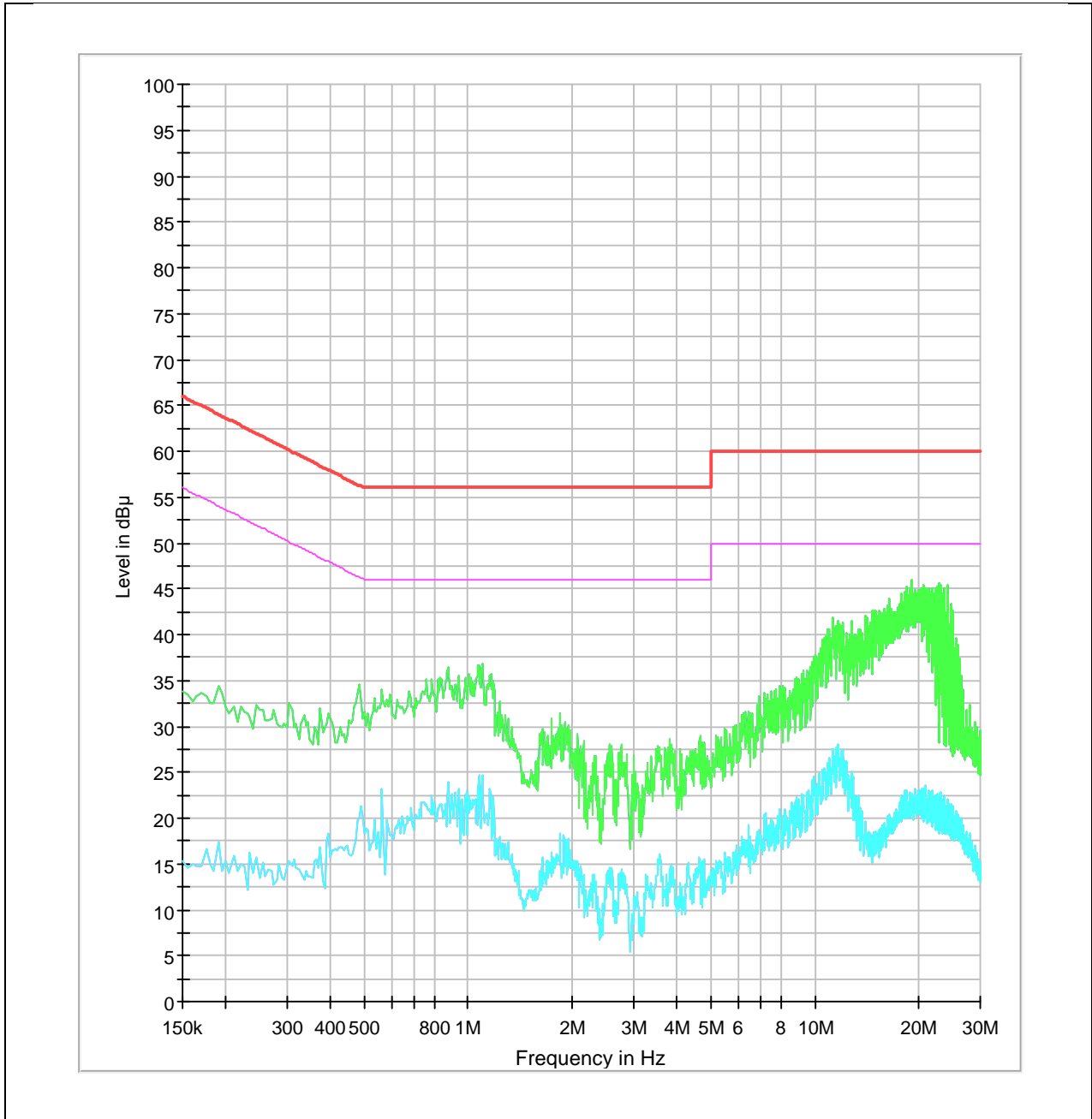

The results shown in this test report refer only to the sample(s) tested unless otherwise stated. This test report cannot be reproduced, except in full, without prior written permission of the Company.

Test mode : (Neutral)

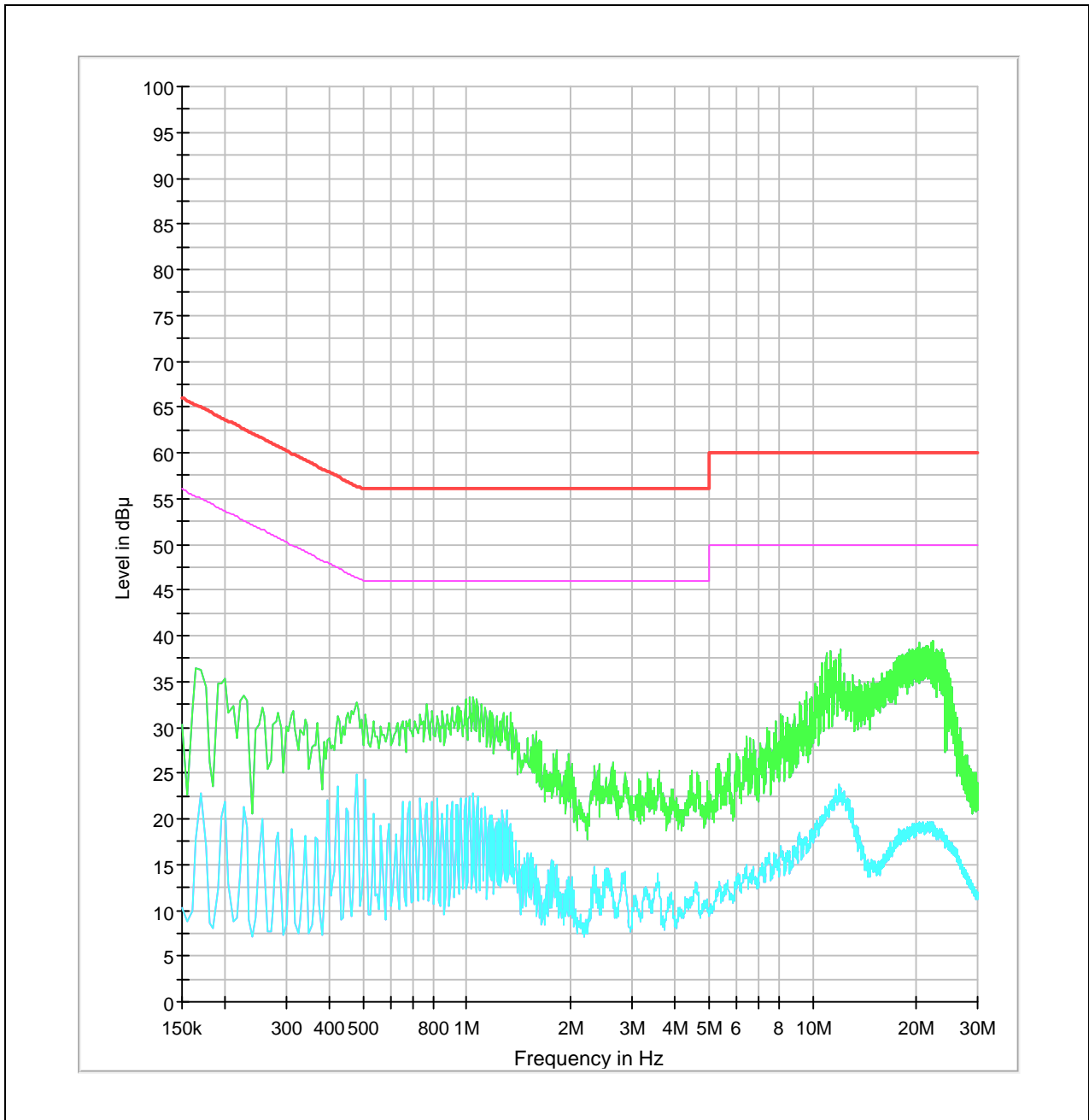

The results shown in this test report refer only to the sample(s) tested unless otherwise stated. This test report cannot be reproduced, except in full, without prior written permission of the Company.

3. Radiated Emissions

3.1. Test Setup

The diagram below shows the test setup that is utilized to make the measurements for emission from 9 kHz to 30 MHz Emissions.

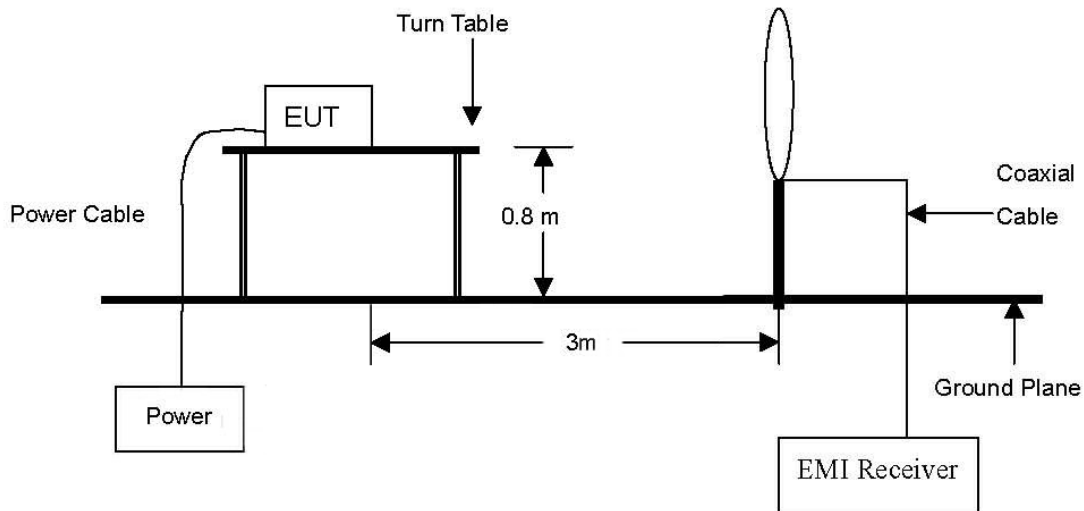

The diagram below shows the test setup that is utilized to make the measurements for emission. The spurious emissions were investigated from 30 MHz to 1 GHz.

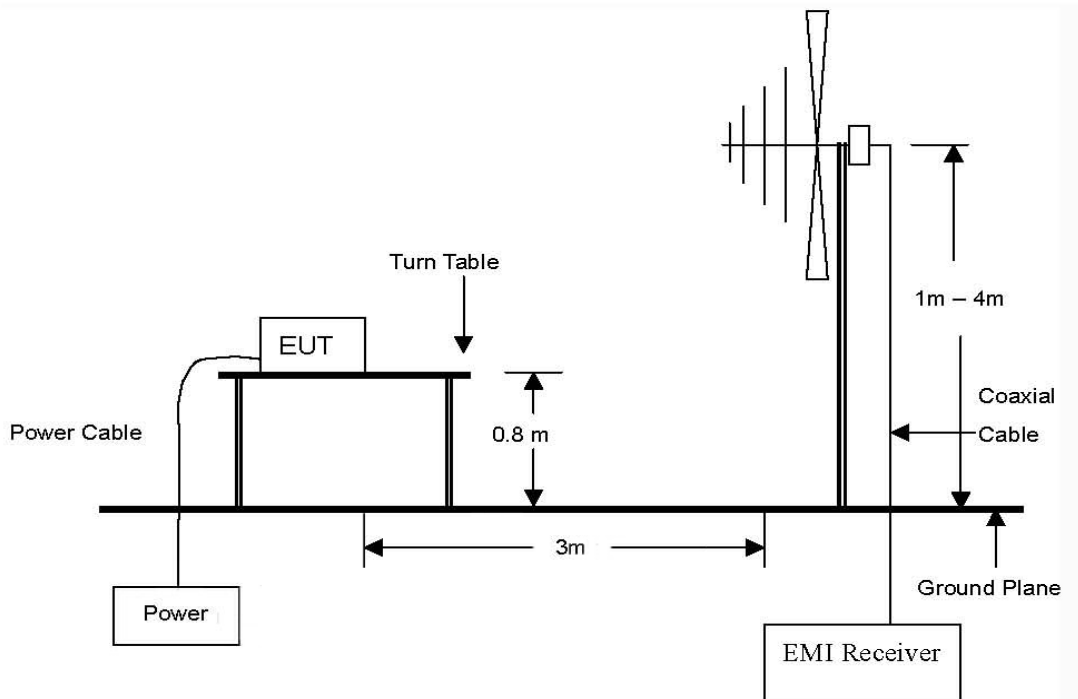

The results shown in this test report refer only to the sample(s) tested unless otherwise stated. This test report cannot be reproduced, except in full, without prior written permission of the Company.

3.2. Limit

According to §15.225,

- (a) The field strength of any emissions within the band 13.553 – 13.567 MHz shall not exceed 15 848 microvolts / meter at 30 meters.
- (b) Within the bands 13.410 – 13.553 MHz and 13.567 – 13.710 MHz, the field strength of any emissions shall not exceed 334 microvolts / meter at 30 meters.
- (c) Within the bands 13.110 – 13.410 MHz and 13.710 – 14.010 MHz the field strength of any emissions shall not exceed 106 microvolts / meter at 30 meters.
- (d) The field strength of any emissions appearing outside of the 13.110 – 14.010 MHz and shall not exceed the general radiated emission limits in §15.209.

3.3. Test Procedures

Radiated emissions from the EUT were measured according to the dictates of ANSI C63.4-2009

- a. The EUT was placed on the top of a rotating table 0.8 meters above the ground at a 3 meter anechoic chamber test site. The table was rotated 360 degrees to determine the position of the highest radiation.
- b. Then antenna is a loop antenna is fixed at one meter above the ground to determine the maximum value of the field strength. Both parallel and perpendicular of the antenna are set to make the measurement.
- c. For each suspected emission, the EUT was arranged to its worst case and then the table was turned from 0 degrees to 360 degrees to find the maximum reading.
- d. The test-receiver system was set to Quasi peak Detect Function with Maximum Hold Mode.
- e. To get a maximum emission level from the EUT, the EUT is manipulated through three orthogonal planes.

NOTE;

All modes were investigated for radiated spurious emissions. Only the radiated emissions of the configuration that produced the worst case emissions are reported in this section.

Worst orthogonal plan of EUT is **Z – axis** during radiation test.

Definition of DUT three orthogonal planes were described in the test setup photo.

The results shown in this test report refer only to the sample(s) tested unless otherwise stated. This test report cannot be reproduced, except in full, without prior written permission of the Company.

3.4. Test Result

Ambient temperature : (24 ± 1) °C

Relative humidity : 47 % R.H.

The following table shows the highest levels of radiated emissions.

-Normal cover

-Fundamental within the band 13.553 – 13.567 MHz

Radiated Emissions			Ant	Correction Factors		Total		FCC Limit	
Freq. (MHz)	Reading (dB μ V)	Detect Mode	Pol.	Ant. Factor (dB/m)	Cable loss (dB)	Actual (dB μ V/m) at 3 m	Actual (dB μ V/m) at 30 m	Limit (dB μ V/m) at 30 m	Margin (dB)
13.56	23.90	Quasi-Peak	H	20.12	0.49	44.51	4.51	84.00	79.49

-Spurious emission within the bands 13.410 – 13.553 MHz and 13.567 -13.710 MHz

Radiated Emissions			Ant.	Correction Factors		Total		FCC Limit	
Freq. (MHz)	Reading (dB μ V)	Detect Mode	Pol.	Ant. Factor (dB/m)	Cable loss (dB)	Actual (dB μ V/m) at 3 m	Actual (dB μ V/m) at 30 m	Limit (dB μ V/m) at 30 m	Margin (dB)
13.54	0.10	Quasi-Peak	H	20.12	0.48	20.70	-19.30	50.47	69.77
13.57	0.10	Quasi-Peak	H	20.12	0.49	20.71	-19.29	50.47	69.76

- Spurious emission within the bands 13.110 – 13.410 MHz and 13.710 – 14.010 MHz

Radiated Emissions			Ant.	Correction Factors		Total		FCC Limit	
Freq. (MHz)	Reading (dB μ V)	Detect Mode	Pol.	Ant. Factor (dB/m)	Cable loss (dB)	Actual (dB μ V/m) at 3 m	Actual (dB μ V/m) at 30 m	Limit (dB μ V/m) at 30 m	Margin (dB)
13.22	-0.10	Quasi-Peak	H	20.11	0.48	20.49	-19.51	40.51	60.02
13.95	0.00	Quasi-Peak	H	20.12	0.49	20.61	-19.39	40.51	59.90

The results shown in this test report refer only to the sample(s) tested unless otherwise stated. This test report cannot be reproduced, except in full, without prior written permission of the Company.

- Spurious emission below 30 MHz except for 13.110 – 14.010 MHz

Radiated Emissions			Ant.	Correction Factors		Total		FCC Limit	
Freq. (MHz)	Reading (dB μ V)	Detect Mode	Pol.	Ant. Factor (dB/m)	Cable loss (dB)	Actual (dB μ V/m) at 3 m	Actual (dB μ V/m) at 30 m	Limit (dB μ V/m) at 30 m	Margin (dB)
2.05	3.70	Quasi-Peak	H	20.05	0.18	23.93	-16.07	29.54	45.61

- Spurious emission within the bands 14.010 – 30 MHz

Radiated Emissions			Ant.	Correction Factors		Total		FCC Limit	
Freq. (MHz)	Reading (dB μ V)	Detect Mode	Pol.	Ant. Factor (dB/m)	Cable loss (dB)	Actual (dB μ V/m) at 3 m	Actual (dB μ V/m) at 30 m	Limit (dB μ V/m) at 30 m	Margin (dB)
*16.423	-0.80	Quasi-Peak	H	20.23	0.58	20.01	-19.99	29.54	49.53
*16.695	-1.00	Quasi-Peak	H	20.19	0.55	19.94	-20.06	29.54	49.60
17.600	-0.80	Quasi-Peak	H	20.20	0.56	19.96	-20.04	29.54	49.58
*25.650	-1.40	Quasi-Peak	H	20.23	0.58	20.01	-19.99	29.54	49.53

The results shown in this test report refer only to the sample(s) tested unless otherwise stated. This test report cannot be reproduced, except in full, without prior written permission of the Company.

- Spurious emission above 30 MHz

Radiated Emissions			Ant.	Correction Factors		Total	FCC Limit	
Freq. (MHz)	Reading (dB μ V)	Detect Mode	Pol.	Ant. Factor (dB/m)	Cable loss & Amp (dB)	Actual (dB μ V/m) at 3 m	Limit (dB μ V/m) at 3 m	Margin (dB)
50.82	33.47	Peak	H	15.70	-26.87	22.30	40.00	17.70
52.92	32.57	Peak	V	14.06	-26.83	19.80	40.00	20.20
102.31	32.96	Peak	H	14.30	-26.26	21.00	43.50	22.50
160.55	34.42	Peak	V	8.45	-25.77	17.10	43.50	26.40
*329.45	34.36	Peak	V	15.92	-24.68	25.60	46.00	20.40
626.47	33.43	Peak	H	20.15	-24.98	28.60	46.00	17.40
Above 700.00	Not detected	-	-	-	-	-	-	-

The results shown in this test report refer only to the sample(s) tested unless otherwise stated. This test report cannot be reproduced, except in full, without prior written permission of the Company.

-Quick cover
-Fundamental within the band 13.553 – 13.567 MHz

Radiated Emissions			Ant.	Correction Factors		Total		FCC Limit	
Freq. (MHz)	Reading (dB μ V)	Detect Mode	Pol.	Ant. Factor (dB/m)	Cable loss (dB)	Actual (dB μ V/m) at 3 m	Actual (dB μ V/m) at 30 m	Limit (dB μ V/m) at 30 m	Margin (dB)
13.56	24.10	Quasi-Peak	H	20.12	0.49	44.71	4.71	84.00	79.29

-Spurious emission within the bands 13.410 – 13.553 MHz and 13.567 -13.710 MHz

Radiated Emissions			Ant.	Correction Factors		Total		FCC Limit	
Freq. (MHz)	Reading (dB μ V)	Detect Mode	Pol.	Ant. Factor (dB/m)	Cable loss (dB)	Actual (dB μ V/m) at 3 m	Actual (dB μ V/m) at 30 m	Limit (dB μ V/m) at 30 m	Margin (dB)
13.50	0.00	Quasi-Peak	H	20.12	0.48	20.60	-19.40	50.47	69.87
13.58	0.20	Quasi-Peak	H	20.12	0.49	20.81	-19.19	50.47	69.66

- Spurious emission within the bands 13.110 – 13.410 MHz and 13.710 – 14.010 MHz

Radiated Emissions			Ant.	Correction Factors		Total		FCC Limit	
Freq. (MHz)	Reading (dB μ V)	Detect Mode	Pol.	Ant. Factor (dB/m)	Cable loss (dB)	Actual (dB μ V/m) at 3 m	Actual (dB μ V/m) at 30 m	Limit (dB μ V/m) at 30 m	Margin (dB)
13.35	0.40	Quasi-Peak	H	20.11	0.48	20.99	-19.01	40.51	59.52
13.76	-0.10	Quasi-Peak	H	20.12	0.49	20.51	-19.49	40.51	60.00

The results shown in this test report refer only to the sample(s) tested unless otherwise stated. This test report cannot be reproduced, except in full, without prior written permission of the Company.

- Spurious emission below 30 MHz except for 13.110 – 14.010 MHz

Radiated Emissions			Ant.	Correction Factors		Total		FCC Limit	
Freq. (MHz)	Reading (dB μ V)	Detect Mode	Pol.	Ant. Factor (dB/m)	Cable loss (dB)	Actual (dB μ V/m) at 3 m	Actual (dB μ V/m) at 30 m	Limit (dB μ V/m) at 30 m	Margin (dB)
2.49	3.20	Quasi-Peak	H	20.04	0.19	23.43	-16.57	29.54	46.11

Radiated Emissions			Ant.	Correction Factors		Total		FCC Limit	
Freq. (MHz)	Reading (dB μ V)	Detect Mode	Pol.	Ant. Factor (dB/m)	Cable loss (dB)	Actual (dB μ V/m) at 3 m	Actual (dB μ V/m) at 30 m	Limit (dB μ V/m) at 30 m	Margin (dB)
15.599	-0.50	Quasi-Peak	H	20.16	0.53	20.19	-19.81	29.54	49.35
*16.423	-0.80	Quasi-Peak	H	20.19	0.55	19.94	-20.06	29.54	49.60
*16.695	-0.80	Quasi-Peak	H	20.20	0.56	19.96	-20.04	29.54	49.58
*25.642	-1.50	Quasi-Peak	H	20.56	0.69	19.75	-20.25	29.54	49.79

- Spurious emission above 30 MHz

Radiated Emissions			Ant.	Correction Factors		Total	FCC Limit	
Freq. (MHz)	Reading (dB μ V)	Detect Mode	Pol.	Ant. Factor (dB/m)	Cable loss & Amp (dB)	Actual (dB μ V/m) at 3 m	Limit (dB μ V/m) at 3 m	Margin (dB)
43.50	32.95	Peak	V	14.57	-26.92	20.60	40.00	19.40
51.06	33.19	Peak	H	15.68	-26.87	22.00	40.00	18.00
100.20	32.75	Peak	V	12.32	-26.27	18.80	43.50	24.70
102.18	32.74	Peak	H	14.32	-26.26	20.80	43.50	22.70
396.26	34.02	Peak	V	16.75	-24.97	25.80	46.00	20.20
528.26	35.73	Peak	H	18.66	-25.19	29.20	46.00	16.80
Above 600.00	Not detected	-	-	-	-	-	-	-

The results shown in this test report refer only to the sample(s) tested unless otherwise stated. This test report cannot be reproduced, except in full, without prior written permission of the Company.

Note:

1. 30 m Limit ($\mu V/m$) = $20 \log (15\ 848) = 84.00$ dB $\mu V/m$.
2. 30 m distance compensation = $40 \log (3/30) = -40$ dB $\mu V/m$.
3. 30 m distance compensation = $40 \log (3/300) = -80$ dB $\mu V/m$.
4. Other Spurious Emission Frequencies were not detected up to 1 000 MHz.
5. Reading values for above 30 MHz are peak values.
6. "*" means the restricted band.

The results shown in this test report refer only to the sample(s) tested unless otherwise stated. This test report cannot be reproduced, except in full, without prior written permission of the Company.

4. Frequency Stability

4.1. Test Setup

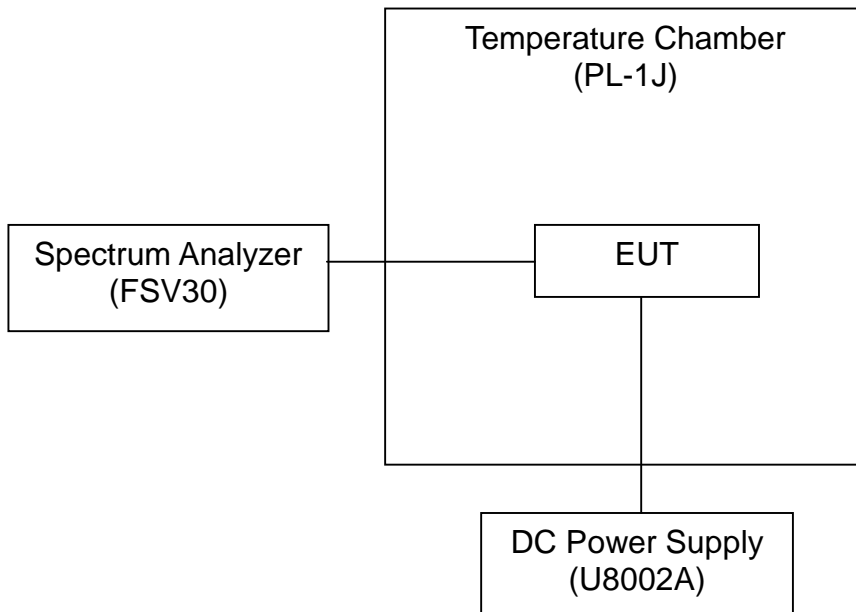

4.2. Limit

According to §15.225(e), the frequency tolerance of the carrier signal shall be maintained within $\pm 0.01\%$ of the operating frequency over a temperature variation of -20 degrees to $+50$ degrees C at normal supply voltage, and for a variation in the primary supply voltage from 85% to 115% of the rated supply voltage at a temperature of 20 degrees C. For battery operated equipment, the equipment tests shall be performed using a new battery.

4.3. Test Procedures

- Place the EUT on the table and set it in the transmitting mode.
- Remove the antenna from the EUT and then connect a low loss RF cable from the antenna port to the spectrum analyzer.
- Set the environment into appropriate environment.
- Set the spectrum analyzer as $RBW = 10 \text{ kHz}$, $VBW = 30 \text{ kHz}$, $Span = 1 \text{ MHz}$, $Sweep \text{ time} = \text{auto}$.
- Mark the peak frequency and measure the frequency tolerance using frequency counter function.
- Repeat until all the results are investigated.

The results shown in this test report refer only to the sample(s) tested unless otherwise stated. This test report cannot be reproduced, except in full, without prior written permission of the Company.

4.4. Test Result

Ambient temperature : (24 ± 1) °C
 Relative humidity : 47 % R.H.

Operating Frequency : 13 560 000 Hz
 Reference Voltage : DC 3.80 V
 Deviation Limit : ±0.01 % = ±1 356 Hz

Temperature Variations

Power (V _{DC})	Temperature (°C)	Frequency (Hz)	Freq. Dev. (Hz)	Deviation (%)
3.80	-20	13 559 242	-758	-0.005 590
	-10	13 559 076	-924	-0.006 814
	0	13 559 170	-830	-0.006 121
	+10	13 558 835	-1 165	-0.008 591
	+24(Ref)	13 559 492	-508	-0.003 746
	+25	13 558 715	-1 285	-0.009 476
	+30	13 559 549	-451	-0.003 326
	+40	13 558 894	-1 106	-0.008 156
	+50	13 559 195	-805	-0.005 937

Voltage Variations

Power (V _{DC})	Temperature (°C)	Frequency (Hz)	Freq. Dev. (Hz)	Deviation (%)
115 % (4.37)	+24	13 559 625	-375	-0.002 765
Battery End Point (3.43)	+24	13 559 241	-759	-0.005 597

The results shown in this test report refer only to the sample(s) tested unless otherwise stated. This test report cannot be reproduced, except in full, without prior written permission of the Company.

5. 20 dB Bandwidth

5.1. Test Setup



5.2. Limit

None ; for reporting purposes only.

5.3. Test Procedures

- Place the EUT on the table and set it in the transmitting mode.
- Remove the antenna from the EUT and then connect a low loss RF cable from the antenna port to the spectrum analyzer.
- Set the spectrum analyzer as RBW = 10 kHz, VBW = 30 kHz, Span = 2 MHz, Sweep time = auto.
- Mark the peak frequency and 20 dB (upper and lower) frequency.
- Repeat until all the rest channels are investigated.

The results shown in this test report refer only to the sample(s) tested unless otherwise stated. This test report cannot be reproduced, except in full, without prior written permission of the Company.

5.4. Test Result

Ambient temperature : (24 ± 1) °C
 Relative humidity : 47 % R.H.

Frequency (MHz)	20 dB Bandwidth (kHz)
13.56	425.50

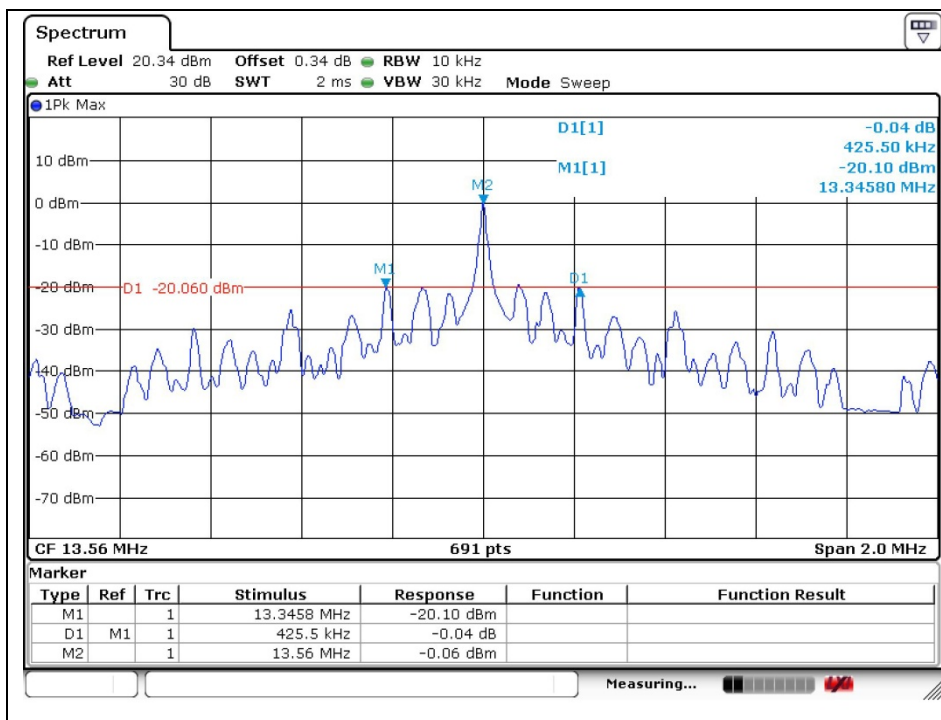

The results shown in this test report refer only to the sample(s) tested unless otherwise stated. This test report cannot be reproduced, except in full, without prior written permission of the Company.