

HCT CO., LTD.

CERTIFICATE OF COMPLIANCE FCC Certification

Applicant Name: LG Electronics MobileComm U.S.A., Inc.	Date of Issue: September 06, 2013
Address: 1000 Sylvan Avenue, Englewood Cliffs NJ 07632	Test Site/Location: HCT CO., LTD., 105-1, Jangam-ri, Majang-Myeon, Icheon-si, Kyunggi-Do, Korea
	Report No.: HCTR1308FR35
	HCT FRN: 0005866421

FCC ID: ZNFD821

APPLICANT: LG Electronics MobileComm U.S.A., Inc.

FCC Model(s):	D821
Additional FCC Model(s):	LG-D821, LGD821
EUT Type:	GSM/WCDMA/LTE Phone with Bluetooth, WLAN(2.4GHz & 5GHz) and NFC
FCC Classification:	Licensed Portable Transmitter Held to Ear (PCE)
FCC Rule Part(s):	§2, §27
Tx Frequency:	2502.5 MHz – 2567.5 MHz (LTE – Band 7): 5 MHz 2505.0 MHz – 2565.0 MHz (LTE – Band 7): 10 MHz 2507.5 MHz – 2562.5 MHz (LTE – Band 7): 15 MHz 2510.0 MHz – 2560.0 MHz (LTE – Band 7): 20 MHz
Max. RF Output Power:	Band 7 (5 MHz) : 0.615 W (QPSK) (27.89 dBm) 0.622 W (16-QAM) (27.94 dBm) Band 7 (10 MHz) : 0.607 W (QPSK) (27.83 dBm) 0.622 W (16-QAM) (27.94 dBm) Band 7 (15 MHz) : 0.646 W (QPSK) (28.10 dBm) 0.658 W (16-QAM) (28.18 dBm) Band 7 (20 MHz) : 0.706 W (QPSK) (28.49 dBm) 0.716 W (16-QAM) (28.55 dBm)
Emission Designator(s):	Band 7 (5 MHz) : 4M51G7D (QPSK) / 4M50W7D (16-QAM) Band 7 (10 MHz) : 9M00G7D (QPSK) / 8M98W7D (16-QAM) Band 7 (15 MHz) : 13M49G7D (QPSK) / 13M46W7D (16-QAM) Band 7 (20 MHz) : 17M95G7D (QPSK) / 17M97W7D (16-QAM)

The measurements shown in this report were made in accordance with the procedures specified in §2.947. I assume full responsibility for the accuracy and completeness of these measurements, and for the qualifications of all persons taking them.

HCT CO., LTD. Certifies that no party to this application has subject to a denial of Federal benefits that includes FCC benefits pursuant to section 5301 of the Anti-Drug Abuse Act of 1998,21 U.S. C.853(a)



Report prepared by
: Kyung Soo Kang
Test engineer of RF Team



Approved by
: Chang Seok Choi
Manager of RF Team

This report only responds to the tested sample and may not be reproduced, except in full, without written approval of the HCT Co., Ltd.

FCC CERTIFICATION REPORT			www.hct.co.kr
Test Report No. HCTR1308FR35	Date of Issue: September 06, 2013	EUT Type: GSM/WCDMA/LTE Phone with Bluetooth, WLAN(2.4GHz & 5GHz) and NFC	FCC ID: ZNFD821



Version

TEST REPORT NO.	DATE	DESCRIPTION
HCTR1308FR35	September 06, 2013	First Approval Report

FCC CERTIFICATION REPORT

www.hct.co.kr

Test Report No.
HCTR1308FR35

Date of Issue:
September 06, 2013

EUT Type:
GSM/WCDMA/LTE Phone with Bluetooth, WLAN(2.4GHz & 5GHz) and NFC

FCC ID:
ZNFD821

Table of Contents

1. GENERAL INFORMATION	4
2. INTRODUCTION	5
2.1. EUT DESCRIPTION.....	5
2.2. MEASURING INSTRUMENT CALIBRATION.....	5
2.3. TEST FACILITY	5
3. DESCRIPTION OF TESTS	6
3.1 ERP/EIRP RADIATED POWER AND RADIATED SPURIOUS EMISSIONS.....	6
3.2 OCCUPIED BANDWIDTH.	7
3.3 SPURIOUS AND HARMONIC EMISSIONS AT ANTENNA TERMINAL.....	7
3.4 PEAK-AVERAGE RATIO.	8
3.5 FREQUENCY STABILITY / VARIATION OF AMBIENT TEMPERATURE	10
4. LIST OF TEST EQUIPMENT	11
5. SUMMARY OF TEST RESULTS	12
6. SAMPLE CALCULATION	13
7. TEST DATA	15
7.1 PEAK-TO-AVERAGE RATIO	15
7.2 OCCUPIED BANDWIDTH	15
7.3 CONDUCTED SPURIOUS EMISSIONS	16
7.3.1 BAND EDGE.....	17
7.4 EQUIVALENT ISOTROPIC RADIATED POWER OUTPUT	18
7.6 RADIATED SPURIOUS EMISSIONS.....	20
7.6.1 EUT ONLY	20
7.6.2 EUT ON THE CHARGING PAD	24
7.7 FREQUENCY STABILITY / VARIATION OF AMBIENT TEMPERATURE	28
7.7.1 FREQUENCY STABILITY (LTE Band 7_5M).....	28
7.7.2 FREQUENCY STABILITY (LTE Band 7_10M).....	29
7.7.3 FREQUENCY STABILITY (LTE Band 7_15M).....	30
7.7.4 FREQUENCY STABILITY (LTE Band 7_20M).....	31
8. TEST PLOTS.....	32



MEASUREMENT REPORT

1. GENERAL INFORMATION

Applicant Name: LG Electronics MobileComm U.S.A., Inc.

Address: 1000 Sylvan Avenue, Englewood Cliffs NJ 07632

FCC ID: ZNFD821

Application Type: Certification

FCC Classification: Licensed Portable Transmitter Held to Ear (PCE)

FCC Rule Part(s): §2 , §27

EUT Type: GSM/WCDMA/LTE Phone with Bluetooth, WLAN(2.4GHz & 5GHz) and NFC

FCC Model(s): D821

Additional FCC Model(s): LG-D821, LGD821

Tx Frequency: 2502.5 MHz – 2567.5 MHz (LTE – Band 7): 5 MHz
2505.0 MHz – 2565.0 MHz (LTE – Band 7): 10 MHz
2507.5 MHz – 2562.5 MHz (LTE – Band 7): 15 MHz
2510.0 MHz – 2560.0 MHz (LTE – Band 7): 20 MHz

Max. RF Output Power:

Band 7 (5 MHz) :	0.615 W (QPSK) (27.89 dBm) 0.622 W (16-QAM) (27.94 dBm)
Band 7 (10 MHz) :	0.607 W (QPSK) (27.83 dBm) 0.622 W (16-QAM) (27.94 dBm)
Band 7 (15 MHz) :	0.646 W (QPSK) (28.10 dBm) 0.658 W (16-QAM) (28.18 dBm)
Band 7 (20 MHz) :	0.706 W (QPSK) (28.49 dBm) 0.716 W (16-QAM) (28.55 dBm)

Emission Designator(s):

Band 7 (5 MHz) :	4M51G7D (QPSK) / 4M50W7D (16-QAM)
Band 7 (10 MHz) :	9M00G7D (QPSK) / 8M98W7D (16-QAM)
Band 7 (15 MHz) :	13M49G7D (QPSK) / 13M46W7D (16-QAM)
Band 7 (20 MHz) :	17M95G7D (QPSK) / 17M97W7D (16-QAM)

Date(s) of Tests: August 01, 2013 ~ September 04, 2013

Antenna Specification Manufacturer: Shanghai Amphenol Airwave Communication Electronics Co., LTD.
Antenna type: Internal Antenna
Peak Gain: LTE Band7 : 0.74 dBi

FCC CERTIFICATION REPORT

Test Report No. HCTR1308FR35	Date of Issue: September 06, 2013	EUT Type: GSM/WCDMA/LTE Phone with Bluetooth, WLAN(2.4GHz & 5GHz) and NFC	www.hct.co.kr FCC ID: ZNFD821
--	---	---	---



2. INTRODUCTION

2.1. EUT DESCRIPTION

The LG Electronics MobileComm U.S.A., Inc. GSM/WCDMA/LTE Phone with Bluetooth, WLAN(2.4GHz & 5GHz) and NFC consists of LTE 7.

2.2. MEASURING INSTRUMENT CALIBRATION

The measuring equipment, which was utilized in performing the tests documented herein, has been calibrated in accordance with the manufacturer's recommendations for utilizing calibration equipment, which is traceable to recognized national standards.

2.3. TEST FACILITY

The Fully-anechoic and conducted measurement facility used to collect the radiated data are located at the 105-1, Jangam-ri, Majang-Myeon, Icheon-si, Kyunggi-Do, 467-811, Korea.

The site is constructed in conformance with the requirements of ANSI C63.4 and CISPR Publication 22. Detailed description of test facility was submitted to the Commission and accepted dated March 02, 2011 (Registration Number: 90661)



3. DESCRIPTION OF TESTS

3.1 ERP/EIRP RADIATED POWER AND RADIATED SPURIOUS EMISSIONS

ERP/EIRP

Note: ERP(Effective Radiated Power), EIRP(Equivalent Isotropic Radiated Power)

Test Procedure

Radiated emission measurements are performed in the Fully-anechoic chamber. The equipment under test is placed on a non-conductive table 3-meters away from the receive antenna in accordance with ANSI/TIA-603-C-2004 Clause 2.2.17. The turntable is rotated through 360 degrees, and the receiving antenna scans in order to determine the level of the maximized emission. The level and position of the maximized emission is recorded with the spectrum analyzer using a positive peak detector.

A half wave dipole is then substituted in place of the EUT. For emissions above 1GHz, a horn antenna is substituted in place of the EUT. The substitute antenna is driven by a signal generator and the previously recorded signal was duplicated.

The power is calculated by the following formula;

$$P_{d(dBm)} = P_{g(dBm)} - \text{cable loss}_{(dB)} + \text{antenna gain}_{(dB)}$$

Where: P_d is the dipole equivalent power and P_g is the generator output power into the substitution antenna.

The maximum EIRP is calculated by adding the forward power to the calibrated source plus its appropriate gain value. These steps are repeated with the receiving antenna in both vertical and horizontal polarization. the difference between the gain of the horn and an isotropic antenna are taken into consideration

Radiated spurious emissions

1. Frequency Range : 30 MHz ~ 10th Harmonics of highest channel fundamental frequency.
2. Measured distance : 30 MHz ~ 11 GHz at 3 m
11 GHz ~ 26 GHz at 1m
3. The EUT was setup to maximum output power. The 100 kHz RBW was used to scan from 30 MHz to 1 GHz. Also, the 1 MHz RBW was used to scan from 1 GHz to 26.5 GHz. And limit is -25 dBm. The high, low and a middle channel were tested for out of band measurements.

FCC CERTIFICATION REPORT

FCC CERTIFICATION REPORT			www.hct.co.kr
Test Report No. HCTR1308FR35	Date of Issue: September 06, 2013	EUT Type: GSM/WCDMA/LTE Phone with Bluetooth, WLAN(2.4GHz & 5GHz) and NFC	FCC ID: ZNF821

3.2 OCCUPIED BANDWIDTH.

Test set-up

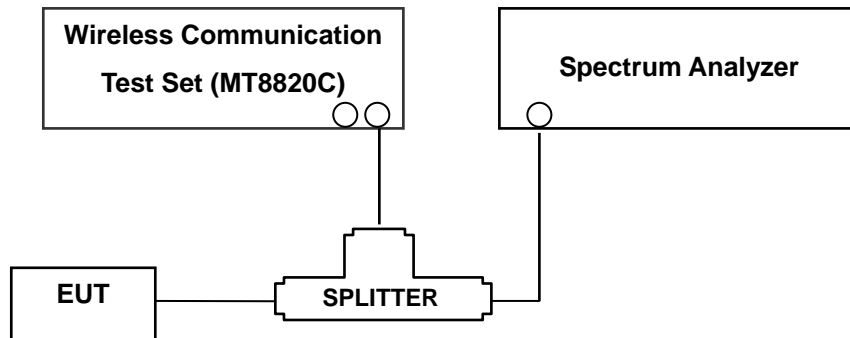

(Configuration of conducted Emission measurement)
Test Procedure

The EUT was setup to maximum output power at its lowest channel. The occupied bandwidth was measured using a spectrum analyzer. The measurements are repeated for the highest and a middle channel. The EUT's occupied bandwidth is measured as the width of the signal between two points, one below the carrier center frequency and one above the carrier frequency, outside of which all emissions are attenuated at least 26 dB below the transmitter power. Plots of the EUT's occupied bandwidth are shown herein.

3.3 SPURIOUS AND HARMONIC EMISSIONS AT ANTENNA TERMINAL.

Test Procedure

The level of the carrier and the various conducted spurious and harmonic frequencies is measured by means of a calibrated spectrum analyzer.

The EUT was setup to maximum output power. The 1 MHz RBW was used to scan from 30 MHz to 26.5 GHz. And limit is -25 dBm. The high, low and a middle channel were tested for out of band measurements.

- Channel Edge Requirement : In the 1MHz bands immediately outside and adjacent to the channel, a resolution bandwidth of at least 1 percent of the emission bandwidth of the fundamental emission of the transmitter may be employed to measure the out of band Emissions. Limit is -13dBm at channel edge and -25dBm at up to 5.5MHz from the channel edge.

NOTES: The analyzer plot offsets were determined by below conditions.

- For LTE Band 7, total offset 28.0 dBm = 20 dBm attenuator + 6 dBm Divider + 2 dBm RF cables.

FCC CERTIFICATION REPORT			www.hct.co.kr
Test Report No. HCTR1308FR35	Date of Issue: September 06, 2013	EUT Type: GSM/WCDMA/LTE Phone with Bluetooth, WLAN(2.4GHz & 5GHz) and NFC	FCC ID: ZNF821

3.4 PEAK-AVERAGE RATIO.

Test Procedure

Peak to Average Power Ratio is tested in accordance with KDB971168 D01 Power Meas License Digital Systems v02r01, June 7, 2013, Section 5.7.

- Section 5.7.1 CCDF Procedure

- a) Set resolution/measurement bandwidth \geq signal's occupied bandwidth;
- b) Set the number of counts to a value that stabilizes the measured CCDF curve;
- c) Set the measurement interval as follows:
 - 1) for continuous transmissions, set to 1 ms,
 - 2) for burst transmissions, employ an external trigger that is synchronized with the EUT burst timing sequence, or use the internal burst trigger with a trigger level that allows the burst to stabilize and set the measurement interval to a time that is less than or equal to the burst duration.
- d) Record the maximum PAPR level associated with a probability of 0.1%.

- Section 5.7.2 Alternate Procedure

Use one of the procedures presented in 5.1 to measure the total peak power and record as P_{Pk} . Use one of the applicable procedures presented 5.2 to measure the total average power and record as P_{Avg} . Determine the P.A.R. from: $P.A.R_{(dB)} = P_{Pk (dBm)} - P_{Avg (dBm)}$ (P_{Avg} = Average Power + Duty cycle Factor)

5.1.1 Peak power measurements with a spectrum/signal analyzer or EMI receiver

The following procedure can be used to determine the total peak output power.

- a) Set the RBW \geq OBW.
- b) Set VBW $\geq 3 \times$ RBW.
- c) Set span $\geq 2 \times$ RBW
- d) Sweep time = auto couple.
- e) Detector = peak.
- f) Ensure that the number of measurement points \geq span/RBW.
- g) Trace mode = max hold.
- h) Allow trace to fully stabilize.
- i) Use the peak marker function to determine the peak amplitude level.

FCC CERTIFICATION REPORT			www.hct.co.kr
Test Report No. HCTR1308FR35	Date of Issue: September 06, 2013	EUT Type: GSM/WCDMA/LTE Phone with Bluetooth, WLAN(2.4GHz & 5GHz) and NFC	FCC ID: ZNF821

5.2.2 Procedures for use with a spectrum/signal analyzer when EUT cannot be configured to transmit continuously and sweep triggering/signal gating cannot be properly implemented

If the EUT cannot be configured to transmit continuously (burst duty cycle < 98%), then one of the following procedures can be used. The selection of the applicable procedure will depend on the characteristics of the measured burst duty cycle.

Measure the burst duty cycle with a spectrum/signal analyzer or EMC receiver can be used in zero-span mode if the response time and spacing between bins on the sweep are sufficient to permit accurate measurement of the burst on/off time of the transmitted signal.

5.2.2.2 Constant burst duty cycle

If the measured burst duty cycle is constant (i.e., duty cycle variations are less than ± 2 percent), then:

- a) Set span to at least 1.5 times the OBW.
- b) Set RBW = 1-5% of the OBW, not to exceed 1 MHz.
- c) Set VBW ≥ 3 x RBW.
- d) Number of points in sweep ≥ 2 × span / RBW. (This gives bin-to-bin spacing ≤ RBW/2, so that narrowband signals are not lost between frequency bins.)
- e) Sweep time = auto.
- f) Detector = RMS (power averaging).
- g) Set sweep trigger to “free run”.
- h) Trace average at least 100 traces in power averaging (i.e., RMS) mode.
- i) Compute power by integrating the spectrum across the OBW of the signal using the instrument’s band power measurement function with band limits set equal to the OBW band edges. If the instrument does not have a band power function, sum the spectrum levels (in power units) at intervals equal to the RBW extending across the entire OBW of the spectrum.
- j) Add 10 log (1/x), where x is the duty cycle, to the measured power in order to compute the average power during the actual transmission times (because the measurement represents an average over both the on and off times of the transmission).

For example, add 10 log (1/0.25) = 6 dB if the duty cycle is a constant 25%.

3.5 FREQUENCY STABILITY / VARIATION OF AMBIENT TEMPERATURE

Test Set-up

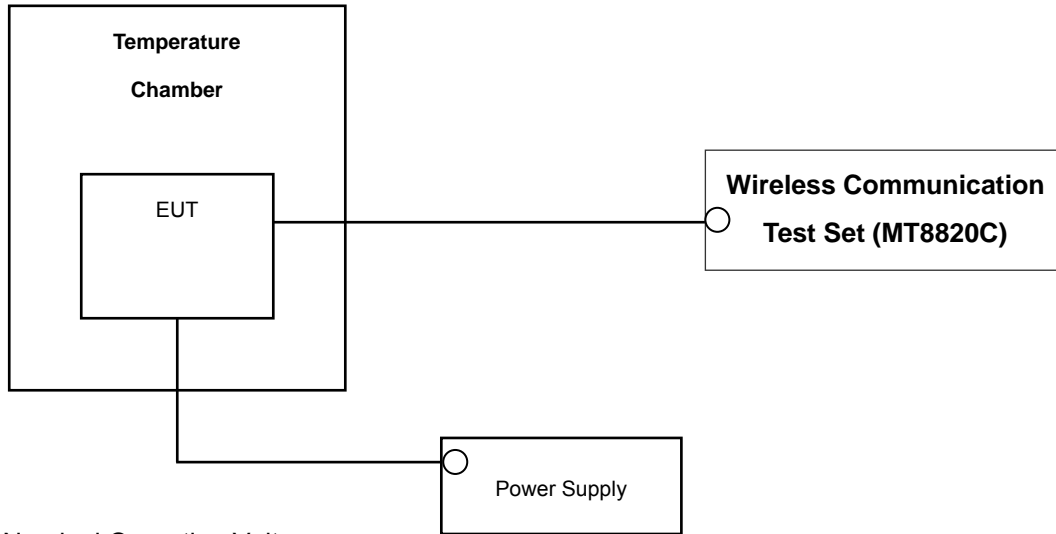

* Nominal Operating Voltage

Test Procedure

The frequency stability of the transmitter is measured by:

a.) **Temperature:** The temperature is varied from - 30 °C to + 50 °C using an environmental chamber.

b.) **Primary Supply Voltage:** The primary supply voltage is varied from battery end point to 115 % of the voltage normally at the input to the device or at the power supply terminals if cables are not normally supplied.

Specification — the frequency stability shall be sufficient to ensure that the fundamental emission stays within the authorized frequency block. The frequency stability of the transmitter shall be maintained within $\pm 0.00025\%$ (± 2.5 ppm) of the center frequency.

Time Period and Procedure:

The carrier frequency of the transmitter is measured at room temperature (20°C to provide a reference).

1. The equipment is turned on in a “standby” condition for one minute before applying power to the transmitter. Measurement of the carrier frequency of the transmitter is made within one minute after applying power to the transmitter.

2. Frequency measurements are made at 10°C intervals ranging from -30°C to +50°C. A period of at least one half-hour is provided to allow stabilization of the equipment at each temperature level.

FCC CERTIFICATION REPORT			www.hct.co.kr
Test Report No. HCTR1308FR35	Date of Issue: September 06, 2013	EUT Type: GSM/WCDMA/LTE Phone with Bluetooth, WLAN(2.4GHz & 5GHz) and NFC	FCC ID: ZNF821

4. LIST OF TEST EQUIPMENT

Manufacture	Model/ Equipment	Serial Number	Calibration Interval	Calibration Due
Agilent	E9327A/ Power Sensor	MY4442009	Annual	04/16/2014
MITEQ	AMF-6D-001180-35-20P/AMP	1081666	Annual	09/11/2013
CERNEX	CBL18265035/AMP	22966	Annual	07/24/2014
Wainwright	WHK1.2/15G-10EF/H.P.F	2	Annual	04/25/2014
Wainwright	WHK3.3/18G-10EF/H.P.F	1	Annual	04/25/2014
Hewlett Packard	11667B / Power Splitter	10126	Annual	11/07/2013
Digital	EP-3010/ Power Supply	3110117	Annual	11/07/2013
Schwarzbeck	UHAP/ Dipole Antenna	557	Biennial	03/05/2015
Schwarzbeck	UHAP/ Dipole Antenna	558	Biennial	05/03/2015
Korea Engineering	KR-1005L / Chamber	KRAB05063-3CH	Annual	11/07/2013
Schwarzbeck	BBHA 9120D/ Horn Antenna	147	Biennial	05/15/2014
Schwarzbeck	BBHA 9120D/ Horn Antenna	937	Biennial	10/17/2013
Schwarzbeck	BBHA9170 / Horn Antenna(15 GHz ~ 40 GHz)	BBHA9170124	Biennial	10/30/2014
Agilent	E9020A/Spectrum Analyzer	MY51110063	Annual	05/14/2014
WEINSCHTEL	ATTENUATOR	BR0592	Annual	11/07/2013
REOHDE&SCHWARZ	FSV40/Spectrum Analyzer	1307.9002K40-100931-NK	Annual	06/10/2014
Agilent	8960 (E5515C)/ Base Station	GB44400269	Annual	02/14/2014

FCC CERTIFICATION REPORT

Test Report No. HCTR1308FR35			Date of Issue: September 06, 2013			EUT Type: GSM/WCDMA/LTE Phone with Bluetooth, WLAN(2.4GHz & 5GHz) and NFC			www.hct.co.kr		
									FCC ID: ZNFD821		

5. SUMMARY OF TEST RESULTS

FCC Part Section(s)	Test Description	Test Limit	Test Condition	Test Result
2.1049,	Occupied Bandwidth	N/A	CONDUCTED	PASS
2.1051, 27.53(m)(4)	Band Edge / Conducted Spurious Emissions.	< 43 +10 log ₁₀ (P[Watts]) at Band Edge and < 55 +10 log ₁₀ (P[Watts]) at 5.5MHz from the Band Edges.		PASS
27.50(d)(5)	Peak-Average Ratio	< 13 dB		PASS
*2.1046	Conducted Output Power	N/A		PASS
2.1055, 27.54	Frequency stability	< 2.5 ppm		PASS
27.50(h)(2)	Equivalent Isotropic Radiated Power	< 2 Watts max. EIRP	RADIATED	PASS
2.1053, 27.53(m)(4)	Undesirable Emissions	< 55 +10 log ₁₀ (P[Watts]) for all out-of-band emissions		PASS

*See SAR Report

6. SAMPLE CALCULATION

A. EIRP Sample Calculation

Mode	Ch./ Freq.		Measured Level(dBm)	Substitute LEVEL(dBm)	Ant. Gain (dBi)	C.L	Pol.	EIRP	
	channel	Freq.(MHz)						W	dBm
LTE Band7	21100	2,535.00	-15.36	19.46	10.72	1.78	V	0.69	28.40

EIRP = SubstituteLEVEL(dBm) + Ant. Gain – CL(Cable Loss)

- 1) The EUT mounted on a wooden tripod is 0.8 meter above test site ground level.
- 2) During the test , the turn table is rotated until the maximum signal is found.
- 3) Record the field strength meter's level.
- 4) Replace the EUT with dipole/Horn antenna that is connected to a calibrated signal generator.
- 5) Increase the signal generator output till the field strength meter's level is equal to the item (3).
- 6) The signal generator output level with Ant. Gain and cable loss are the rating of Equivalent Isotropic Radiated Power (**EIRP**).



B. Emission Designator

QPSK Modulation

5MHz Bandwidth

Emission Designator = 4M48G7D

LTE BW = 4.48 MHz

G = Phase Modulation

7 = Quantized/Digital Info

D = Data transmission; telemetry; telecommand

10MHz Bandwidth

Emission Designator = 8M95G7D

LTE BW = 8.95 MHz

G = Phase Modulation

7 = Quantized/Digital Info

D = Data transmission; telemetry; telecommand

15MHz Bandwidth

Emission Designator = 13M47G7D

LTE BW = 13.47 MHz

G = Phase Modulation

7 = Quantized/Digital Info

D = Data transmission; telemetry; telecommand

20MHz Bandwidth

Emission Designator = 18M03G7D

LTE BW = 18.03 MHz

G = Phase Modulation

7 = Quantized/Digital Info

D = Data transmission; telemetry; telecommand

16QAM Modulation

5MHz Bandwidth

Emission Designator = 4M48W7D

LTE BW = 4.48 MHz

W = main carrier modulated in a combination of two or more of the following modes;
amplitude, angle, pulse

7 = Quantized/Digital Info

D = Data transmission; telemetry; telecommand

10MHz Bandwidth

Emission Designator = 8M94W7D

LTE BW = 8.94 MHz

W = main carrier modulated in a combination of two or more of the following modes;
amplitude, angle, pulse

7 = Quantized/Digital Info

D = Data transmission; telemetry; telecommand

5MHz Bandwidth

Emission Designator = 13M47W7D

LTE BW = 13.47MHz

W = main carrier modulated in a combination of two or more of the following modes;
amplitude, angle, pulse

7 = Quantized/Digital Info

D = Data transmission; telemetry; telecommand

10MHz Bandwidth

Emission Designator = 18M03W7D

LTE BW = 18.03 MHz

W = main carrier modulated in a combination of two or more of the following modes;
amplitude, angle, pulse

7 = Quantized/Digital Info

D = Data transmission; telemetry; telecommand

FCC CERTIFICATION REPORT

FCC CERTIFICATION REPORT			www.hct.co.kr
Test Report No. HCTR1308FR35	Date of Issue: September 06, 2013	EUT Type: GSM/WCDMA/LTE Phone with Bluetooth, WLAN(2.4GHz & 5GHz) and NFC	FCC ID: ZNF0821

7. TEST DATA

7.1 PEAK-TO-AVERAGE RATIO

Band	Band Width	Frequency (MHz)	Modulation	Resource Block Size	Resource Block Offset	Data (dB)
Band 7	5 MHz	2535.0	QPSK	25	0	4.62
			16-QAM	25	0	5.66
	10 MHz	2535.0	QPSK	50	0	4.76
			16-QAM	50	0	5.74
	15 MHz	2535.0	QPSK	75	0	4.60
			16-QAM	75	0	5.88
	20 MHz	2535.0	QPSK	100	0	4.64
			16-QAM	100	0	5.77

- Plots of the EUT's Peak- to- Average Ratio are shown Page 37 ~ 40

7.2 OCCUPIED BANDWIDTH

Band	Band Width (MHz)	Frequency (MHz)	Modulation	Resource Block Size	Resource Block Offset	Data (MHz)
Band 7	5	2535.0	QPSK	25	0	4.5091
			16-QAM	25	0	4.5043
	10	2535.0	QPSK	50	0	8.9953
			16-QAM	50	0	8.9832
	15	2535.0	QPSK	75	0	13.486
			16-QAM	75	0	13.460
	20	2535.0	QPSK	100	0	17.948
			16-QAM	100	0	17.965

- Plots of the EUT's Occupied Bandwidth are shown Page 33 ~ 36

7.3 CONDUCTED SPURIOUS EMISSIONS

Band	Band Width (MHz)	Frequency (Mhz)	Modulation	Resource Block Size	Resource Block Offset	Frequency of Maximum Harmonic (GHz)	Maximum Data [dBm]
Band 7	5	2502.5	QPSK	1	0	10.309820	-28.78
		2535.0		1	0	10.313080	-28.79
		2567.5		1	0	6.998930	-28.74
	10	2505.0		1	0	13.928520	-29.31
		2535.0		1	0	10.294920	-28.85
		2565.0		1	0	6.943520	-28.19
	15	2507.5		1	0	10.303310	-28.55
		2535.0		1	0	8.842510	-28.42
		2562.5		1	0	10.282350	-29.02
	20	2510.0		1	0	11.760380	-28.71
		2535.0		1	0	13.678920	-29.27
		2560.0		1	0	6.852720	-28.98

- Plots of the EUT's Conducted Spurious Emissions are shown Page 47 ~ 58

7.3.1 BAND EDGE

Band	Band Width (MHz)	Frequency (Mhz)	Modulation	Resource Block Size	Resource Block Offset	Channel Edge Data [dBm]			
						Channel Edge (Limit: -13dBm)		At 5.5MHz from Channel Edge (Limit: -25dBm)	
						Lower	Upper	Lower	Upper
Band 7	5	2502.5	QPSK	25	0	-19.26	-19.01	-30.72	-29.65
		2535.0		25	0	-20.66	-21.66	-30.46	-31.11
		2567.5		25	0	-20.66	-21.74	-30.89	-32.28
	10	2505.0		50	0	-22.94	-23.35	-25.71	-25.05
		2535.0		50	0	-23.54	-25.50	-25.32	-27.01
		2565.0		50	0	-24.46	-24.70	-26.56	-28.42
	15	2507.5		75	0	-23.72	-22.21	-26.63	-25.46
		2535.0		75	0	-25.36	-26.33	-26.22	-29.17
		2562.5		75	0	-25.18	-24.33	-28.15	-28.02
	20	2510.0		100	0	-26.00	-24.63	-28.49	-25.84
		2535.0		100	0	-25.52	-28.18	-27.58	-29.98
		2560.0		100	0	-28.24	-25.96	-30.27	-28.42

- Plots of the EUT's Band Edge are shown Page 41 ~ 46

7.4 EQUIVALENT ISOTROPIC RADIATED POWER OUTPUT

Effective Radiated Power Data (Band 7 – 5 MHz)

Freq (MHz)	Bandwidth	Modulation	Measured Level (dBm)	Substitute Level (dBm)	Ant. Gain(dBi)	C.L	Pol	EIRP	
								W	dBm
2502.5	5 MHz	QPSK	-16.19	18.80	10.64	1.75	V	0.587	27.69
		16-QAM	-16.25	18.74	10.64	1.75	V	0.579	27.63
2535.0		QPSK	-15.87	18.95	10.72	1.78	V	0.615	27.89
		16-QAM	-15.82	19.00	10.72	1.78	V	0.622	27.94
2567.5		QPSK	-16.28	18.49	10.77	1.85	V	0.551	27.41
		16-QAM	-16.23	18.54	10.77	1.85	V	0.557	27.46

Note: Worst case is 1 resource block.

Effective Radiated Power Data (Band 7 – 10 MHz)

Freq (MHz)	Bandwidth	Modulation	Measured Level (dBm)	Substitute Level (dBm)	Ant. Gain(dBi)	C.L	Pol	EIRP	
								W	dBm
2505.0	10 MHz	QPSK	-16.19	18.79	10.64	1.76	V	0.585	27.67
		16-QAM	-16.32	18.66	10.64	1.76	V	0.568	27.54
2535.0		QPSK	-15.93	18.89	10.72	1.78	V	0.607	27.83
		16-QAM	-15.82	19.00	10.72	1.78	V	0.622	27.94
2565.0		QPSK	-16.34	18.45	10.77	1.77	V	0.556	27.45
		16-QAM	-16.10	18.69	10.77	1.77	V	0.587	27.69

Note: Worst case is 1 resource block.

Effective Radiated Power Data (Band 7 – 15 MHz)

Freq (MHz)	Bandwidth	Modulation	Measured Level (dBm)	Substitute Level (dBm)	Ant. Gain(dBi)	C.L	Pol	EIRP	
								W	dBm
2507.5	15 MHz	QPSK	-16.33	18.49	10.65	1.76	V	0.547	27.38
		16-QAM	-16.23	18.59	10.65	1.76	V	0.560	27.48
2535.0		QPSK	-15.84	18.98	10.72	1.78	V	0.619	27.92
		16-QAM	-15.87	18.95	10.72	1.78	V	0.615	27.89
2562.5		QPSK	-16.01	19.24	10.77	1.91	V	0.646	28.10
		16-QAM	-15.93	19.32	10.77	1.91	V	0.658	28.18

Note: Worst case is 1 resource block.

Effective Radiated Power Data (Band 7 – 20 MHz)

Freq (MHz)	Bandwidth	Modulation	Measured Level (dBm)	Substitute Level (dBm)	Ant. Gain(dBi)	C.L	Pol	EIRP	
								W	dBm
2510.0	20 MHz	QPSK	-16.40	18.51	10.66	1.87	V	0.537	27.30
		16-QAM	-16.21	18.70	10.66	1.87	V	0.561	27.49
2535.0		QPSK	-15.27	19.55	10.72	1.78	V	0.706	28.49
		16-QAM	-15.21	19.61	10.72	1.78	V	0.716	28.55
2560.0		QPSK	-16.17	19.01	10.77	1.88	V	0.617	27.90
		16-QAM	-15.88	19.30	10.77	1.88	V	0.659	28.19

Note: Worst case is 1 resource block.

NOTES:

Effective Radiated Power Output Measurements by Substitution Method

according to ANSI/TIA/EIA-603-C-2004, Aug. 17, 2004:

The EUT was placed on a non-conductive styrofoam resin table 3-meters from the receive antenna. The receive antenna height and turntable rotation was adjusted for the highest reading on the receive spectrum analyzer. For 1 MHz BW signals, a peak detector is used, with RBW = VBW = 1 MHz. For 10 MHz BW signals, a peak detector is used, with RBW = VBW = 10 MHz. A half-wave dipole was substituted in place of the EUT. This dipole antenna was driven by a signal generator and the level of the signal generator was adjusted to obtain the same receive spectrum analyzer reading. The conducted power at the terminals of the Horn antenna is measured. The difference between the gain of the horn and an isotropic antenna is taken into consideration and the EIRP is recorded.

Also, we have done x, y, z planes in EUT and horizontal and vertical polarization in detecting antenna. The worst case of the EUT is x plane in LTE mode. Also worst case of detecting Antenna is horizontal polarization in LTE mode.

FCC CERTIFICATION REPORT

Test Report No. HCTR1308FR35	Date of Issue: September 06, 2013	EUT Type: GSM/WCDMA/LTE Phone with Bluetooth, WLAN(2.4GHz & 5GHz) and NFC	www.hct.co.kr FCC ID: ZNF821
--	---	---	--



7.6 RADIATED SPURIOUS EMISSIONS

7.6.1 EUT ONLY

7.6.1.1 RADIATED SPURIOUS EMISSIONS (Band 7_5M)

OPERATING FREQUENCY : 2535.00 MHz
 MEASURED OUTPUT POWER: 27.94 dBm = 0.622W
 MODULATION SIGNAL: 5 MHz 16-QAM
 DISTANCE: 3 meters
 LIMIT: $55 + 10 \log_{10}(W) =$ 52.94 dBc

Ch	Freq (MHz)	Measured Level (dBm)	Ant. Gain (dBi)	Substitute Level (dBm)	C.L	Pol	EIRP (dBm)	dBc
20775 (2502.5)	5005.0	-52.53	12.69	-52.95	2.66	H	-42.92	70.86
	7507.5	-52.70	11.53	-43.08	3.40	H	-34.95	62.89
	10010.0	-	-	-	-	-	-	-
21100 (2535.0)	5070.0	-52.50	12.75	-52.16	2.71	H	-42.12	70.06
	7605.0	-53.60	11.65	-43.86	3.32	V	-35.53	63.47
	10140.0	-	-	-	-	-	-	-
21425 (2567.5)	5135.0	-53.83	12.86	-53.50	2.71	V	-43.35	71.29
	7702.5	-56.02	11.76	-46.65	3.32	V	-38.21	66.15
	10270.0	-	-	-	-	-	-	-

- NOTES:**
1. Radiated Spurious Emission Measurements at 1 meter and 3 meter by Substitution Method according to ANSI/TIA/EIA-603-C-2004, Aug. 17, 2004:
 2. We are performed all frequency to 10th harmonics from 30 MHz. Measurements above show only up to 3 maximum emissions noted, or would be lesser if no specific emissions from the EUT are recorded (ie: margin > 20 dB from the applicable limit) and considered that's already beyond the background noise floor.
 3. we have done x, y, z planes in EUT and horizontal and vertical polarization in detecting antenna.
 4. Worst case is 1 resource block.

FCC CERTIFICATION REPORT			www.hct.co.kr
Test Report No. HCTR1308FR35	Date of Issue: September 06, 2013	EUT Type: GSM/WCDMA/LTE Phone with Bluetooth, WLAN(2.4GHz & 5GHz) and NFC	FCC ID: ZNF821



7.6.1.2 RADIATED SPURIOUS EMISSIONS (Band 7_10M)

OPERATING FREQUENCY : 2535.00 MHz
 MEASURED OUTPUT POWER: 27.94 dBm = 0.622W
 MODULATION SIGNAL: 10 MHz 16-QAM
 DISTANCE: 3 meters
 LIMIT: $55 + 10 \log_{10}(W) =$ 52.94 dBc

Ch	Freq (MHz)	Measured Level (dBm)	Ant. Gain (dBi)	Substitute Level (dBm)	C.L	Pol	EIRP (dBm)	dBc
20800 (2505.0)	5010.0	-52.87	12.69	-53.29	2.66	V	-43.26	71.20
	7515.0	-54.32	11.55	-44.80	3.34	V	-36.59	64.53
	10020.0	-	-	-	-	-	-	-
21100 (2535.0)	5070.0	-52.17	12.75	-51.83	2.71	H	-41.79	69.73
	7605.0	-56.28	11.65	-46.54	3.32	H	-38.21	66.15
	10140.0	-	-	-	-	-	-	-
21400 (2565.0)	5130.0	-54.39	12.85	-54.07	2.71	V	-43.93	71.87
	7695.0	-54.70	11.75	-45.32	3.32	H	-36.89	64.83
	10260.0	-	-	-	-	-	-	-

- NOTES:**
1. Radiated Spurious Emission Measurements at 1 meter and 3 meter by Substitution Method according to ANSI/TIA/EIA-603-C-2004, Aug. 17, 2004:
 2. We are performed all frequency to 10th harmonics from 30 MHz. Measurements above show only up to 3 maximum emissions noted, or would be lesser if no specific emissions from the EUT are recorded (ie: margin > 20 dB from the applicable limit) and considered that's already beyond the background noise floor.
 3. we have done x, y, z planes in EUT and horizontal and vertical polarization in detecting antenna.
 4. Worst case is 1 resource block.



7.6.1.3 RADIATED SPURIOUS EMISSIONS (Band 7_15M)

OPERATING FREQUENCY : 2535.00 MHz
 MEASURED OUTPUT POWER: 28.18 dBm = 0.658W
 MODULATION SIGNAL: 15 MHz 16-QAM
 DISTANCE: 3 meters
 LIMIT: $55 + 10 \log_{10}(W) =$ 53.18 dBc

Ch	Freq (MHz)	Measured Level (dBm)	Ant. Gain (dBi)	Substitute Level (dBm)	C.L	Pol	EIRP (dBm)	dBc
20825 (2507.5)	5015.0	-52.76	12.69	-52.94	2.65	H	-42.90	71.08
	7522.5	-54.89	11.57	-45.09	3.34	V	-36.86	65.04
	10030.0	-	-	-	-	-	-	-
21100 (2535.0)	5070.0	-52.80	12.75	-52.46	2.71	V	-42.42	70.60
	7605.0	-55.46	11.65	-45.72	3.32	H	-37.39	65.57
	10140.0	-	-	-	-	-	-	-
21375 (2562.5)	5125.0	-53.78	12.85	-53.42	2.70	V	-43.27	71.45
	7687.5	-56.26	11.74	-47.02	3.34	H	-38.62	66.80
	10250.0	-	-	-	-	-	-	-

- NOTES:**
1. Radiated Spurious Emission Measurements at 1 meter and 3 meter by Substitution Method according to ANSI/TIA/EIA-603-C-2004, Aug. 17, 2004:
 2. We are performed all frequency to 10th harmonics from 30 MHz. Measurements above show only up to 3 maximum emissions noted, or would be lesser if no specific emissions from the EUT are recorded (ie: margin > 20 dB from the applicable limit) and considered that's already beyond the background noise floor.
 3. we have done x, y, z planes in EUT and horizontal and vertical polarization in detecting antenna.
 4. Worst case is 1 resource block.



7.6.1.4 RADIATED SPURIOUS EMISSIONS (Band 7_20M)

OPERATING FREQUENCY : 2535.00 MHz
 MEASURED OUTPUT POWER: 28.55 dBm = 0.716 W
 MODULATION SIGNAL: 20 MHz 16-QAM
 DISTANCE: 3 meters
 LIMIT: $55 + 10 \log_{10}(W) =$ 53.55 dBc

Ch	Freq (MHz)	Measured Level (dBm)	Ant. Gain (dBi)	Substitute Level (dBm)	C.L	Pol	EIRP (dBm)	dBc
20850 (2510.0)	5020.0	-52.27	12.69	-52.45	2.65	H	-42.41	70.96
	7530.0	-54.31	11.57	-44.44	3.41	V	-36.28	64.83
	10040.0	-	-	-	-	-	-	-
21100 (2535.0)	5070.0	-53.16	12.75	-52.82	2.71	H	-42.78	71.33
	7605.0	-56.40	11.65	-46.66	3.32	H	-38.33	66.88
	10140.0	-	-	-	-	-	-	-
21350 (2560.0)	5120.0	-53.88	12.84	-53.51	2.70	H	-43.37	71.92
	7680.0	-55.02	11.74	-45.87	3.36	H	-37.49	66.04
	10240.0	-	-	-	-	-	-	-

- NOTES:**
1. Radiated Spurious Emission Measurements at 1 meter and 3 meter by Substitution Method according to ANSI/TIA/EIA-603-C-2004, Aug. 17, 2004:
 2. We are performed all frequency to 10th harmonics from 30 MHz. Measurements above show only up to 3 maximum emissions noted, or would be lesser if no specific emissions from the EUT are recorded (ie: margin > 20 dB from the applicable limit) and considered that's already beyond the background noise floor.
 3. we have done x, y, z planes in EUT and horizontal and vertical polarization in detecting antenna.
 4. Worst case is 1 resource block.

7.6.2 EUT ON THE CHARGING PAD

7.6.2.1 RADIATED SPURIOUS EMISSIONS (Band 7_5M)

MODULATION SIGNAL: _____ 5 MHz 16-QAM
 DISTANCE: _____ 3 meters
 LIMIT: _____ - 25 dBm

Ch	Freq (MHz)	Measured Level (dBm)	Ant. Gain (dBi)	Substitute Level (dBm)	C.L	Pol	EIRP (dBm)
20775 (2502.5)	5005.0	-55.79	12.69	-56.21	2.66	H	-46.18
	7498.8	-57.06	11.53	-47.44	3.40	V	-39.31
	10010.0	-	-	-	-	-	-
21100 (2535.0)	5070.0	-56.55	12.75	-56.21	2.71	H	-46.17
	7605.0	-	-	-	-	-	-
	10140.0	-	-	-	-	-	-
21425 (2567.5)	5135.0	-54.74	12.86	-54.41	2.71	H	-44.26
	7702.5	-	-	-	-	-	-
	10270.0	-	-	-	-	-	-

- NOTES:**
1. Radiated Spurious Emission Measurements at 1 meter and 3 meter by Substitution Method according to ANSI/TIA/EIA-603-C-2004, Aug. 17, 2004:
 2. We are performed all frequency to 10th harmonics from 30 MHz. Measurements above show only up to 3 maximum emissions noted, or would be lesser if no specific emissions from the EUT are recorded (ie: margin > 20 dB from the applicable limit) and considered that's already beyond the background noise floor.
 3. we have done x, y, z planes in EUT and horizontal and vertical polarization in detecting antenna.
 4. Worst case is 1 resource block.



7.6.2.2 RADIATED SPURIOUS EMISSIONS (Band 7_10M)

MODULATION SIGNAL: _____ 10 MHz 16-QAM

DISTANCE: _____ 3 meters

LIMIT: _____ -25 dBm

Ch	Freq (MHz)	Measured Level (dBm)	Ant. Gain (dBi)	Substitute Level (dBm)	C.L	Pol	EIRP (dBm)	dBc
20800 (2505.0)	5010.0	-54.75	12.69	-55.17	2.66	H	-45.14	73.08
	7515.0	-57.64	11.55	-48.12	3.34	V	-39.91	67.85
	10020.0	-	-	-	-	-	-	7.36
21100 (2535.0)	5070.0	-55.24	12.75	-54.90	2.71	H	-44.86	72.80
	7605.0	-	-	-	-	-	-	9.87
	10140.0	-	-	-	-	-	-	7.44
21400 (2565.0)	5130.0	-56.03	12.85	-55.71	2.71	H	-45.57	73.51
	7695.0	-57.72	11.75	-48.34	3.32	V	-39.91	67.85
	10260.0	-	-	-	-	-	-	6.69

- NOTES:**
1. Radiated Spurious Emission Measurements at 1 meter and 3 meter by Substitution Method according to ANSI/TIA/EIA-603-C-2004, Aug. 17, 2004:
 2. We are performed all frequency to 10th harmonics from 30 MHz. Measurements above show only up to 3 maximum emissions noted, or would be lesser if no specific emissions from the EUT are recorded (ie: margin > 20 dB from the applicable limit) and considered that's already beyond the background noise floor.
 3. we have done x, y, z planes in EUT and horizontal and vertical polarization in detecting antenna.
 4. Worst case is 1 resource block.

7.6.2.3 RADIATED SPURIOUS EMISSIONS (Band 7_15M)

MODULATION SIGNAL: _____ 15 MHz 16-QAM

DISTANCE: _____ 3 meters

LIMIT: _____ - 25 dBm

Ch	Freq (MHz)	Measured Level (dBm)	Ant. Gain (dBi)	Substitute Level (dBm)	C.L	Pol	EIRP (dBm)
20825 (2507.5)	5015.0	-53.95	12.69	-54.13	2.65	H	-44.09
	7522.5	-56.77	11.57	-46.97	3.34	H	-38.74
	10030.0	-	-	-	-	-	-
21100 (2535.0)	5070.0	-54.44	12.75	-54.10	2.71	H	-44.06
	7605.0	-56.87	11.65	-47.13	3.32	H	-38.80
	10140.0	-	-	-	-	-	-
21375 (2562.5)	5125.0	-56.59	12.85	-56.23	2.70	H	-46.08
	7687.5	-	-	-	-	-	-
	10250.0	-	-	-	-	-	-

- NOTES:**
1. Radiated Spurious Emission Measurements at 1 meter and 3 meter by Substitution Method according to ANSI/TIA/EIA-603-C-2004, Aug. 17, 2004:
 2. We are performed all frequency to 10th harmonics from 30 MHz. Measurements above show only up to 3 maximum emissions noted, or would be lesser if no specific emissions from the EUT are recorded (ie: margin > 20 dB from the applicable limit) and considered that's already beyond the background noise floor.
 3. we have done x, y, z planes in EUT and horizontal and vertical polarization in detecting antenna.
 4. Worst case is 1 resource block.



7.6.2.4 RADIATED SPURIOUS EMISSIONS (Band 7_20M)

MODULATION SIGNAL: _____ 20 MHz 16-QAM

DISTANCE: _____ 3 meters

LIMIT: _____ - 25 dBm

Ch	Freq (MHz)	Measured Level (dBm)	Ant. Gain (dBi)	Substitute Level (dBm)	C.L	Pol	EIRP (dBm)
20850 (2510.0)	5020.0	-54.48	12.69	-54.66	2.65	V	-44.62
	7530.0	-56.55	11.57	-46.68	3.41	H	-38.52
	10040.0	-	-	-	-	-	-
21100 (2535.0)	5070.0	-55.00	12.75	-54.66	2.71	H	-44.62
	7605.0	-57.01	11.65	-47.27	3.32	V	-38.94
	10140.0	-	-	-	-	-	-
21350 (2560.0)	5120.0	-55.63	12.84	-55.26	2.70	H	-45.12
	7680.0	-	-	-	-	-	-
	10240.0	-	-	-	-	-	-

- NOTES:**
1. Radiated Spurious Emission Measurements at 1 meter and 3 meter by Substitution Method according to ANSI/TIA/EIA-603-C-2004, Aug. 17, 2004:
 2. We are performed all frequency to 10th harmonics from 30 MHz. Measurements above show only up to 3 maximum emissions noted, or would be lesser if no specific emissions from the EUT are recorded (ie: margin > 20 dB from the applicable limit) and considered that's already beyond the background noise floor.
 3. we have done x, y, z planes in EUT and horizontal and vertical polarization in detecting antenna.
 4. Worst case is 1 resource block.

FCC CERTIFICATION REPORT			www.hct.co.kr
Test Report No. HCTR1308FR35	Date of Issue: September 06, 2013	EUT Type: GSM/WCDMA/LTE Phone with Bluetooth, WLAN(2.4GHz & 5GHz) and NFC	FCC ID: ZNFD821

7.7 FREQUENCY STABILITY / VARIATION OF AMBIENT TEMPERATURE

7.7.1 FREQUENCY STABILITY (LTE Band 7_5M)

OPERATING FREQUENCY: 2535.000,000 Hz
 CHANNEL: 21100 (5 MHz)
 REFERENCE VOLTAGE: 3.8 VDC
 DEVIATION LIMIT: ± 0.000 25 % or 2.5 ppm

Voltage (%)	Power (VDC)	Temp. ()	Frequency (Hz)	Frequency Error (Hz)	Deviation (%)	ppm
100%	3.800	+20(Ref)	2535 000 000	0.0	0.000 000	0.000
100%		-30	2535 000 003	3.3	0.000 000	0.001
100%		-20	2535 000 001	0.5	0.000 000	0.000
100%		-10	2535 000 006	6.0	0.000 000	0.002
100%		0	2535 000 005	5.3	0.000 000	0.002
100%		+10	2535 000 000	0.0	0.000 000	0.000
100%		+30	2534 999 992	-8.5	0.000 000	-0.003
100%		+40	2534 999 991	-8.7	0.000 000	-0.003
100%		+50	2534 999 989	-11.2	0.000 000	-0.004
115%	4.370	+20	2534 999 986	-14.1	-0.000 001	-0.006
Batt. Endpoint	3.500	+20	2534 999 992	-8.4	0.000 000	-0.003

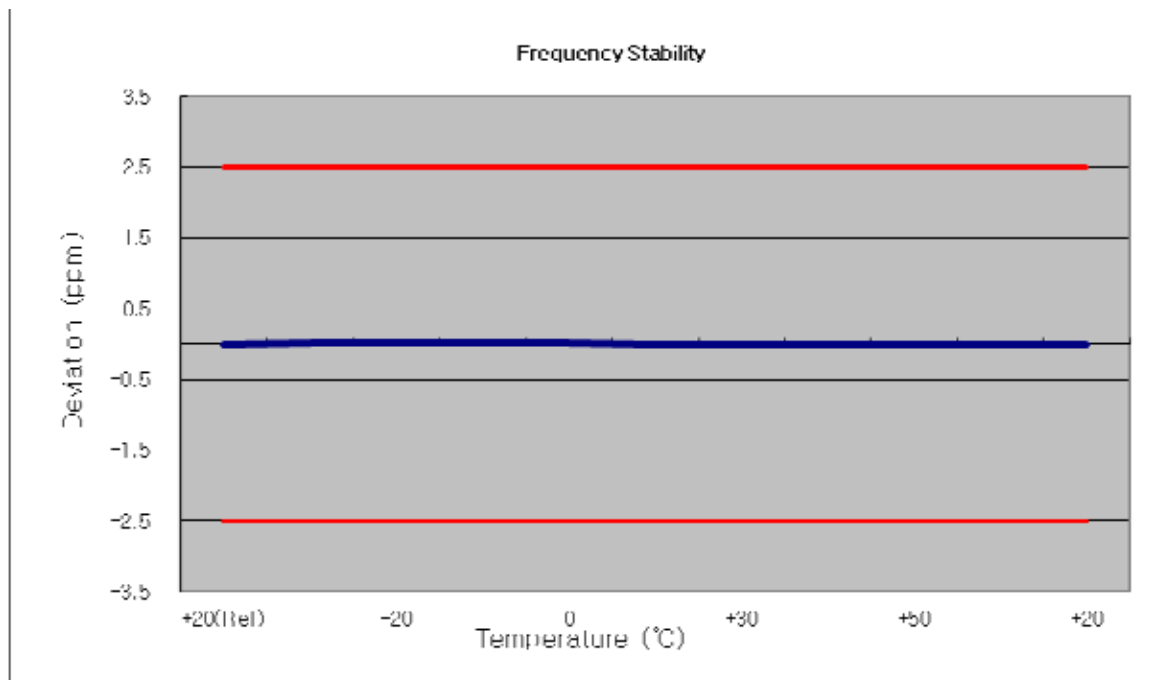

FCC CERTIFICATION REPORT

Test Report No. HCTR1308FR35	Date of Issue: September 06, 2013	EUT Type: GSM/WCDMA/LTE Phone with Bluetooth, WLAN(2.4GHz & 5GHz) and NFC	www.hct.co.kr FCC ID: ZNFD821
---------------------------------	--------------------------------------	--	--

7.7.2 FREQUENCY STABILITY (LTE Band 7_10M)

OPERATING FREQUENCY: 2535.000,000 Hz
 CHANNEL: 21100 (10 MHz)
 REFERENCE VOLTAGE: 3.8 VDC
 DEVIATION LIMIT: ± 0.000 25 % or 2.5 ppm

Voltage (%)	Power (VDC)	Temp. ()	Frequency (Hz)	Frequency Error (Hz)	Deviation (%)	ppm
100%	3.800	+20(Ref)	2534 999 993	0.0	0.000 000	0.000
100%		-30	2534 999 985	-7.8	0.000 000	-0.003
100%		-20	2534 999 978	-14.5	-0.000 001	-0.006
100%		-10	2534 999 982	-11.0	0.000 000	-0.004
100%		0	2534 999 984	-8.4	0.000 000	-0.003
100%		+10	2534 999 983	-9.5	0.000 000	-0.004
100%		+30	2534 999 988	-4.3	0.000 000	-0.002
100%		+40	2534 999 983	-9.9	0.000 000	-0.004
100%		+50	2534 999 983	-9.2	0.000 000	-0.004
115%	4.370	+20	2534 999 991	-2.1	0.000 000	-0.001
Batt. Endpoint	3.500	+20	2534 999 985	-7.5	0.000 000	-0.003

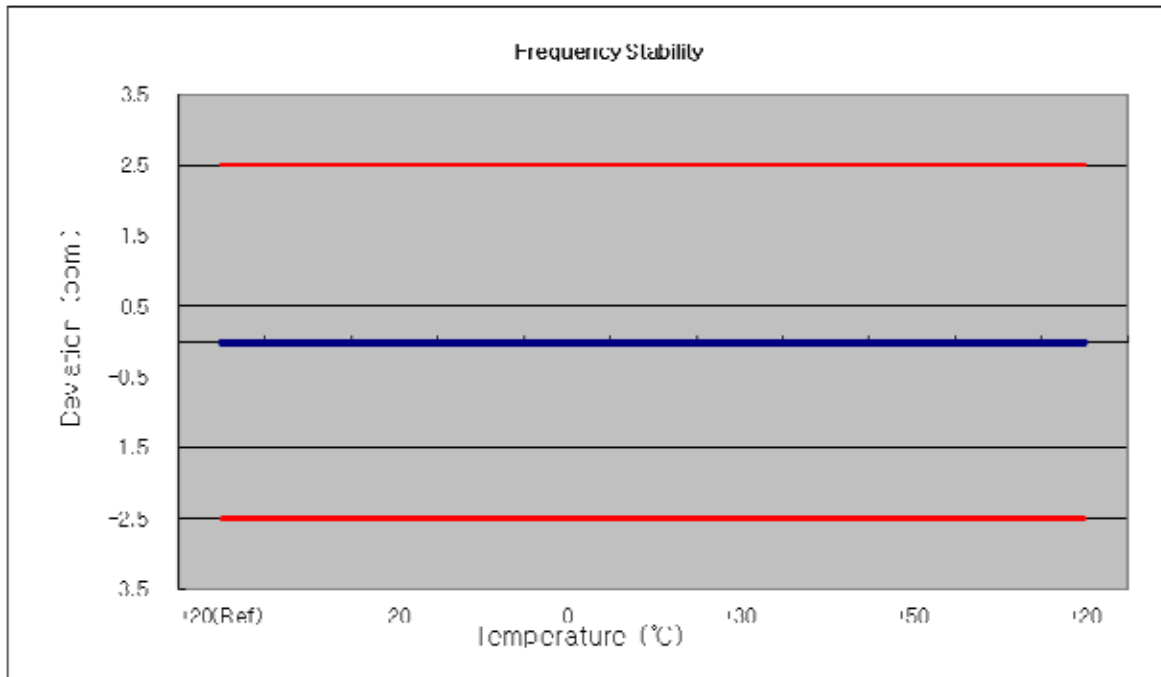

FCC CERTIFICATION REPORT

Test Report No.
HCTR1308FR35

Date of Issue:
September 06, 2013

EUT Type:
GSM/WCDMA/LTE Phone with Bluetooth, WLAN(2.4GHz & 5GHz) and NFC

www.hct.co.kr

FCC ID:
ZNF821

7.7.3 FREQUENCY STABILITY (LTE Band 7_15M)

OPERATING FREQUENCY: 2535.000,000 Hz
 CHANNEL: 21100 (15 MHz)
 REFERENCE VOLTAGE: 3.8 VDC
 DEVIATION LIMIT: ± 0.000 25 % or 2.5 ppm

Voltage (%)	Power (VDC)	Temp. ()	Frequency (Hz)	Frequency Error (Hz)	Deviation (%)	ppm
100%	3.800	+20(Ref)	2535 000 005	0.0	0.000 000	0.000
100%		-30	2535 000 006	1.6	0.000 000	0.001
100%		-20	2535 000 015	10.2	0.000 000	0.004
100%		-10	2535 000 011	6.3	0.000 000	0.002
100%		0	2535 000 014	9.5	0.000 000	0.004
100%		+10	2535 000 025	20.0	0.000 001	0.008
100%		+30	2534 999 992	-12.4	0.000 000	-0.005
100%		+40	2534 999 999	-6.1	0.000 000	-0.002
100%		+50	2535 000 005	0.1	0.000 000	0.000
115%	4.370	+20	2534 999 999	-5.6	0.000 000	-0.002
Batt. Endpoint	3.500	+20	2535 000 000	-5.0	0.000 000	-0.002

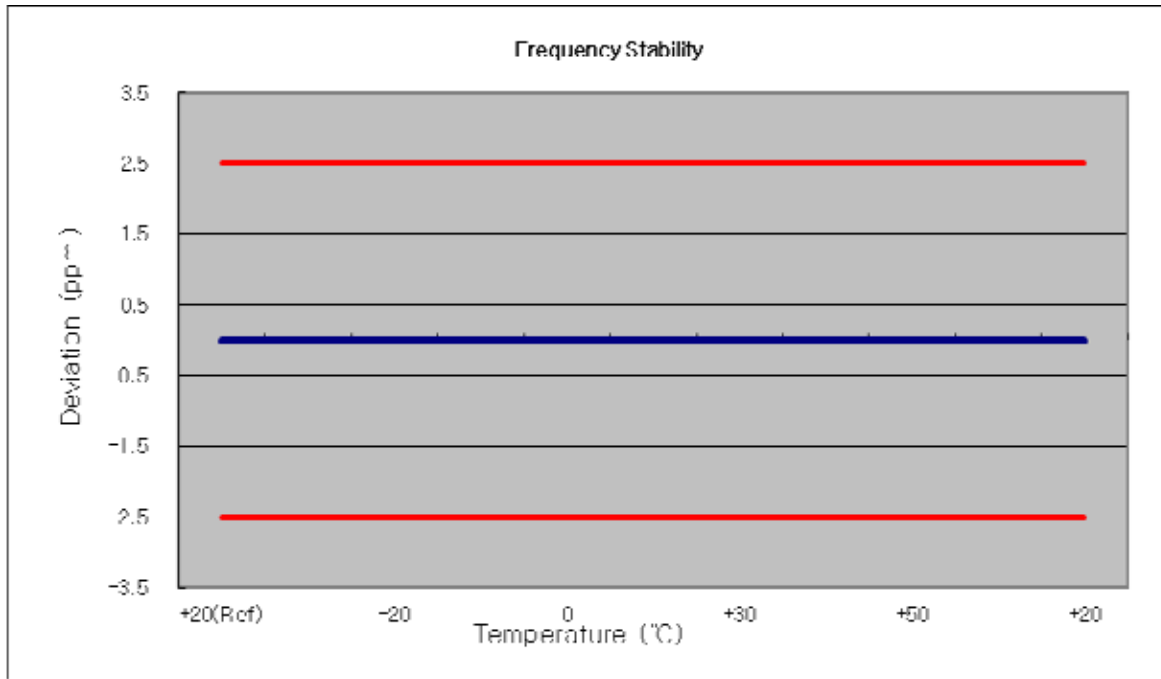

FCC CERTIFICATION REPORT

Test Report No. HCTR1308FR35	Date of Issue: September 06, 2013	EUT Type: GSM/WCDMA/LTE Phone with Bluetooth, WLAN(2.4GHz & 5GHz) and NFC	www.hct.co.kr FCC ID: ZNF821
---------------------------------	--------------------------------------	--	---

7.7.4 FREQUENCY STABILITY (LTE Band 7_20M)

OPERATING FREQUENCY: 2535.000,000 Hz
 CHANNEL: 21100 (20 MHz)
 REFERENCE VOLTAGE: 3.8 VDC
 DEVIATION LIMIT: ± 0.000 25 % or 2.5 ppm

Voltage (%)	Power (VDC)	Temp. ()	Frequency (Hz)	Frequency Error (Hz)	Deviation (%)	ppm
100%	3.800	+20(Ref)	2535 000 014	0.0	0.000 000	0.000
100%		-30	2535 000 030	16.5	0.000 001	0.007
100%		-20	2535 000 002	-11.6	0.000 000	-0.005
100%		-10	2535 000 001	-12.8	-0.000 001	-0.005
100%		0	2535 000 007	-7.1	0.000 000	-0.003
100%		+10	2535 000 009	-4.9	0.000 000	-0.002
100%		+30	2535 000 025	11.0	0.000 000	0.004
100%		+40	2535 000 026	11.8	0.000 000	0.005
100%		+50	2534 999 986	-27.5	-0.000 001	-0.011
115%	4.370	+20	2534 999 999	-14.3	-0.000 001	-0.006
Batt. Endpoint	3.500	+20	2535 000 003	-10.9	0.000 000	-0.004

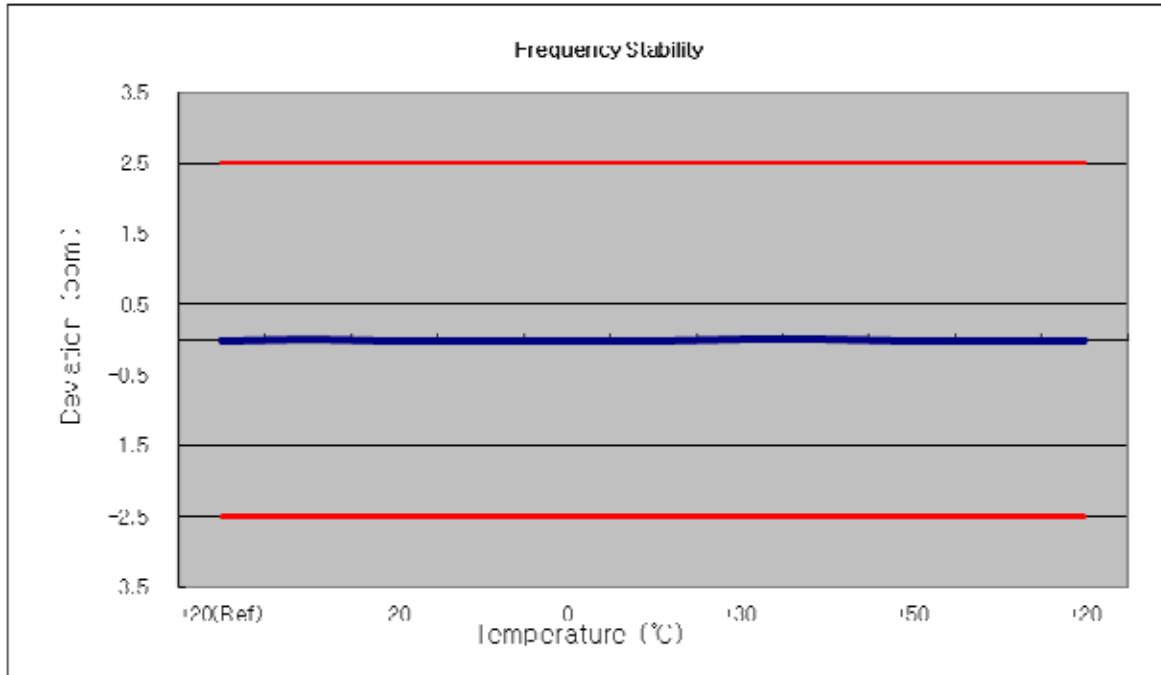

FCC CERTIFICATION REPORT

Test Report No. HCTR1308FR35	Date of Issue: September 06, 2013	EUT Type: GSM/WCDMA/LTE Phone with Bluetooth, WLAN(2.4GHz & 5GHz) and NFC	www.hct.co.kr FCC ID: ZNF821
---------------------------------	--------------------------------------	--	---



8. TEST PLOTS

FCC CERTIFICATION REPORT			www.hct.co.kr
Test Report No. HCTR1308FR35	Date of Issue: September 06, 2013	EUT Type: GSM/WCDMA/LTE Phone with Bluetooth, WLAN(2.4GHz & 5GHz) and NFC	FCC ID: ZNFD821

Occupied Bandwidth Plot (21100 ch_5 MHz_QPSK_RB Size 25)

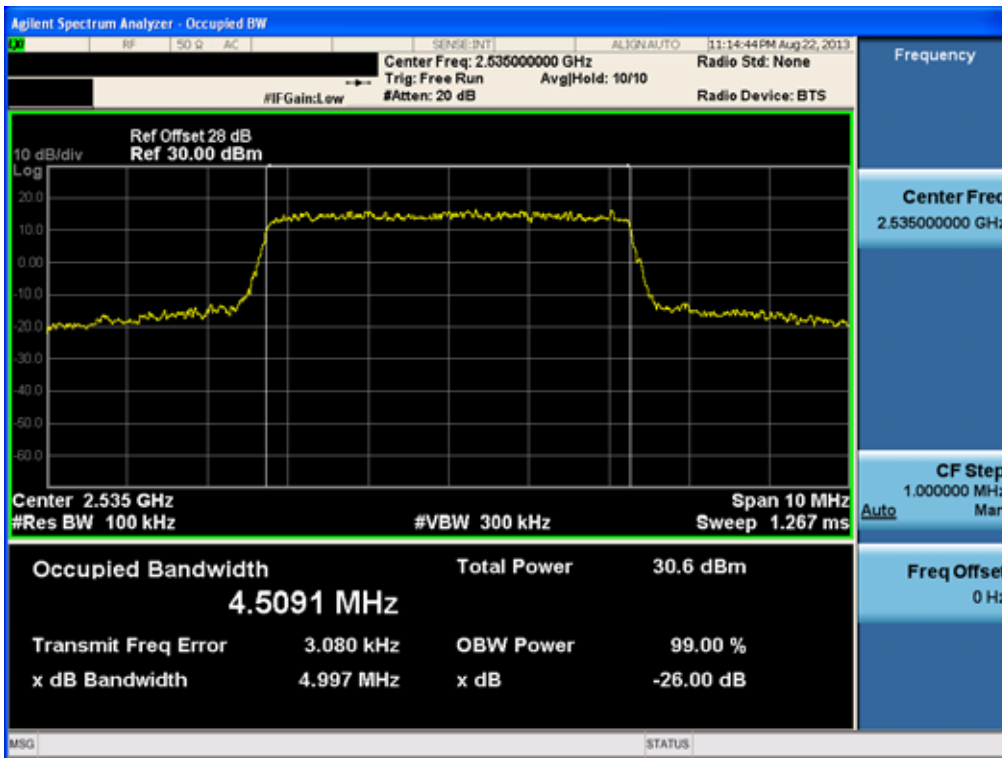

Occupied Bandwidth Plot (21100 ch_5 MHz_16-QAM_RB 25)

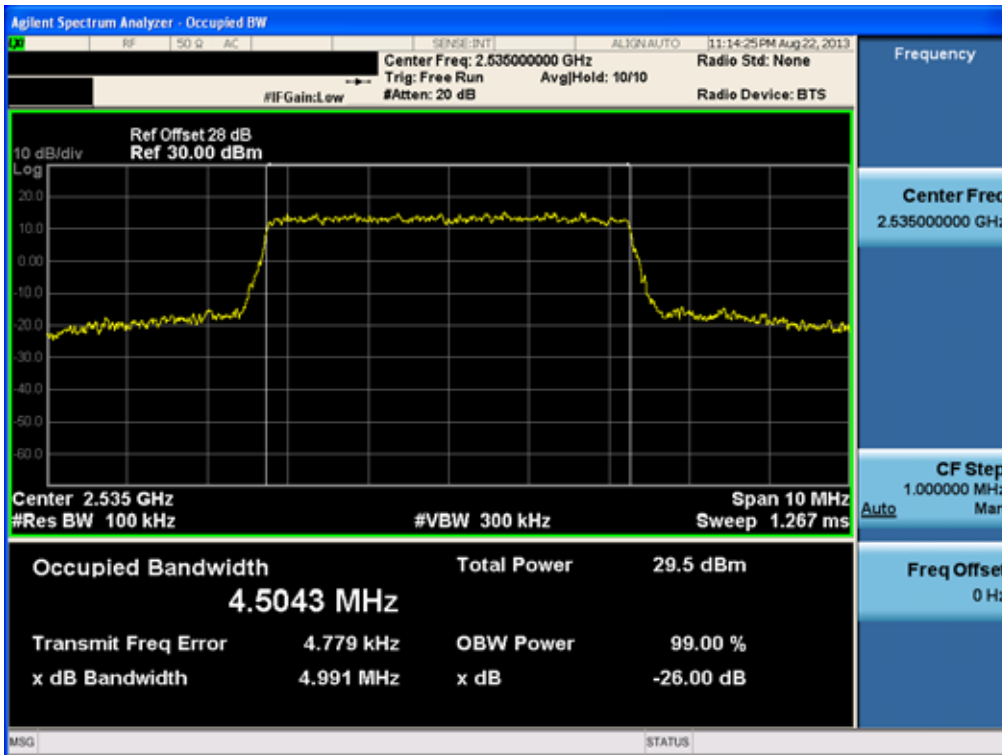

FCC CERTIFICATION REPORT

Test Report No. HCTR1308FR35	Date of Issue: September 06, 2013	EUT Type: GSM/WCDMA/LTE Phone with Bluetooth, WLAN(2.4GHz & 5GHz) and NFC	www.hct.co.kr FCC ID: ZNFD821
---------------------------------	--------------------------------------	--	--

Occupied Bandwidth Plot (21100 ch_10 MHz_QPSK_RB 50)

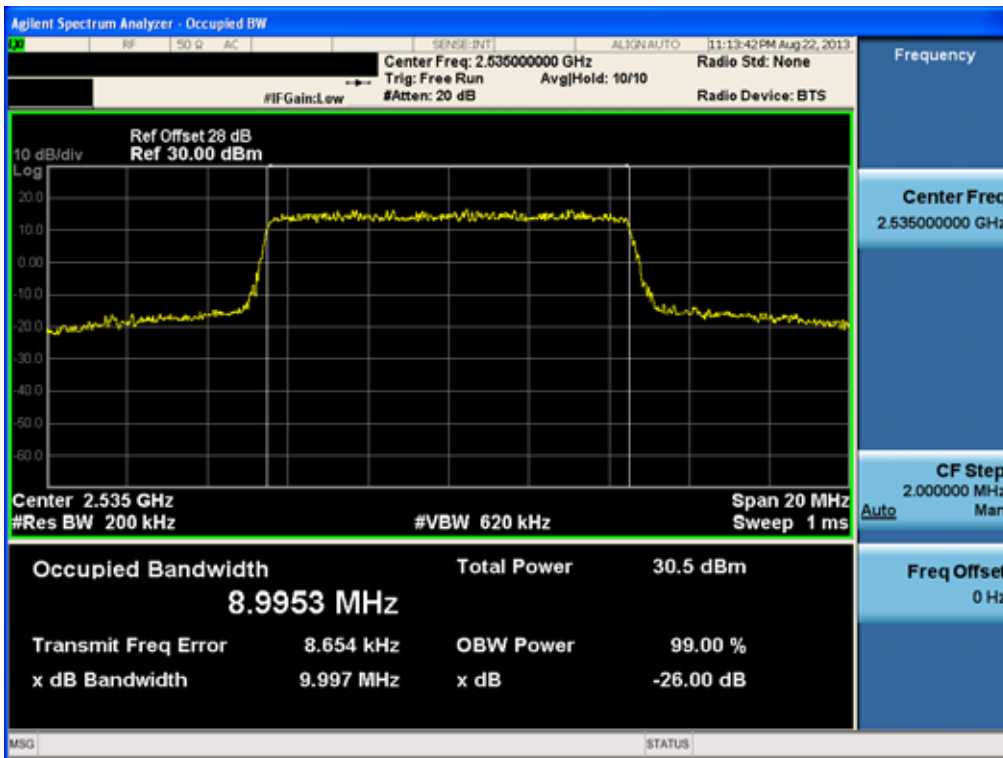

Occupied Bandwidth Plot (21100 ch_10 MHz_16-QAM_RB 50)

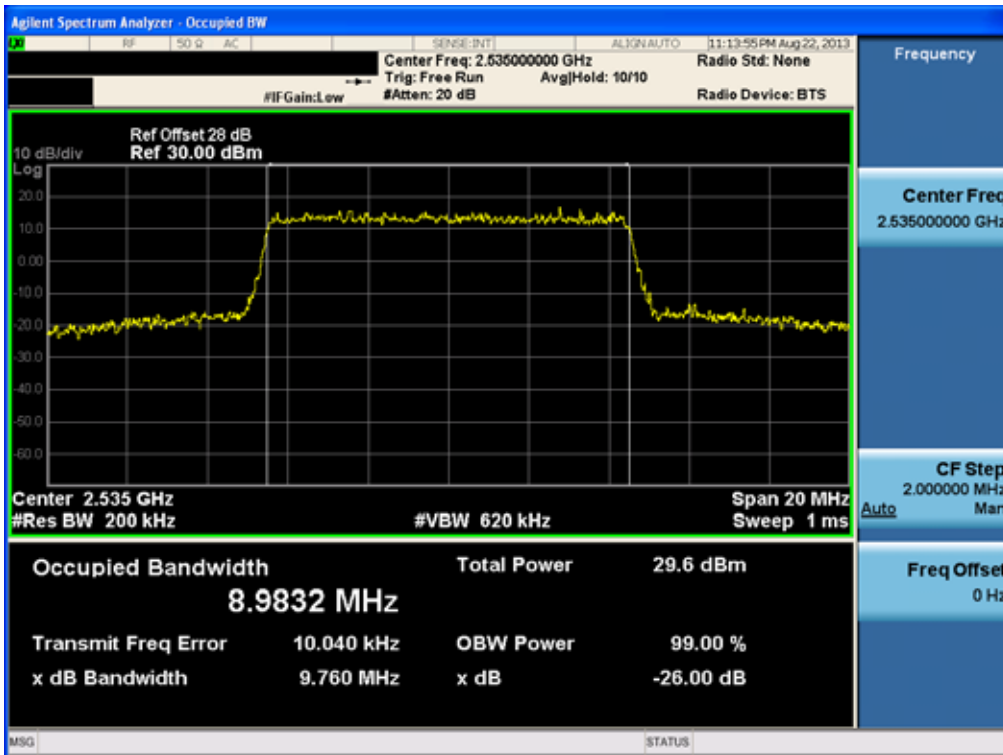

FCC CERTIFICATION REPORT

Test Report No. HCTR1308FR35	Date of Issue: September 06, 2013	EUT Type: GSM/WCDMA/LTE Phone with Bluetooth, WLAN(2.4GHz & 5GHz) and NFC	www.hct.co.kr FCC ID: ZNFD821
---------------------------------	--------------------------------------	--	--

Occupied Bandwidth Plot (21100 ch_15 MHz_QPSK_RB Size 75)

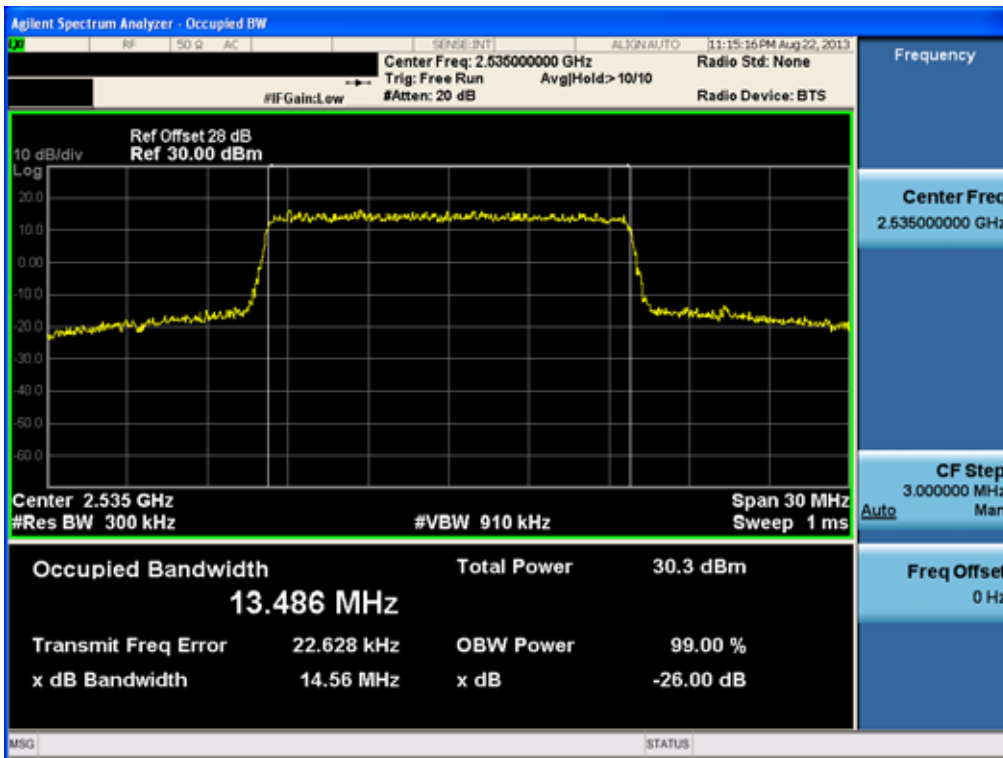

Occupied Bandwidth Plot (21100 ch_15 MHz_16-QAM_RB 75)

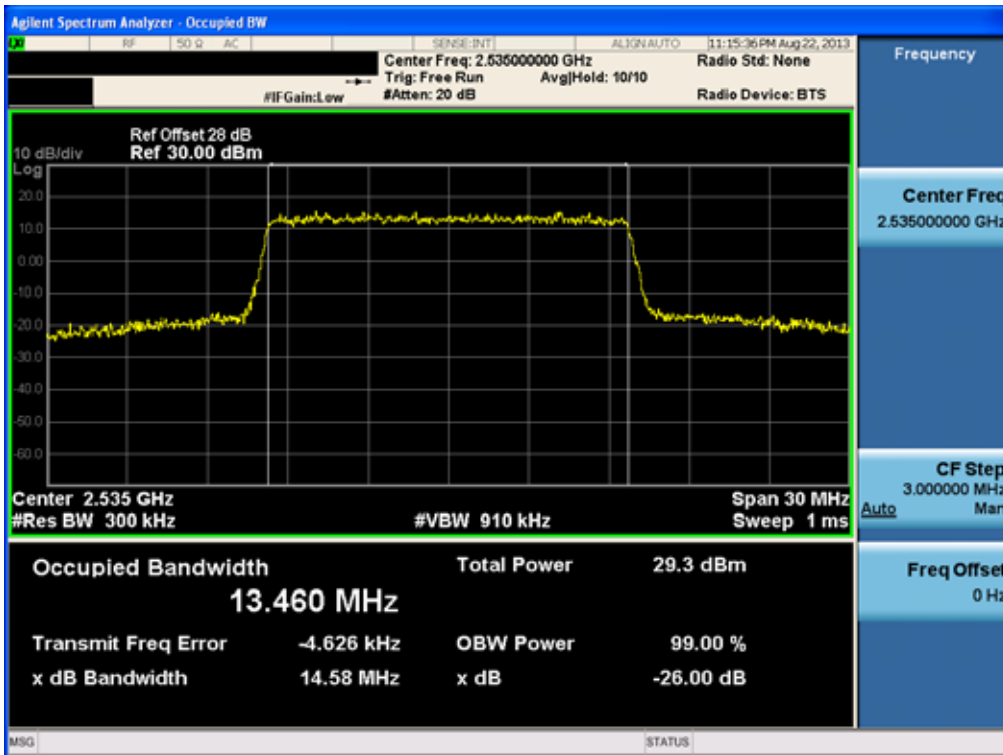

FCC CERTIFICATION REPORT

Test Report No. HCTR1308FR35	Date of Issue: September 06, 2013	EUT Type: GSM/WCDMA/LTE Phone with Bluetooth, WLAN(2.4GHz & 5GHz) and NFC	www.hct.co.kr FCC ID: ZNFD821
---------------------------------	--------------------------------------	--	--

Occupied Bandwidth Plot (21100 ch_20 MHz_QPSK_RB 100)

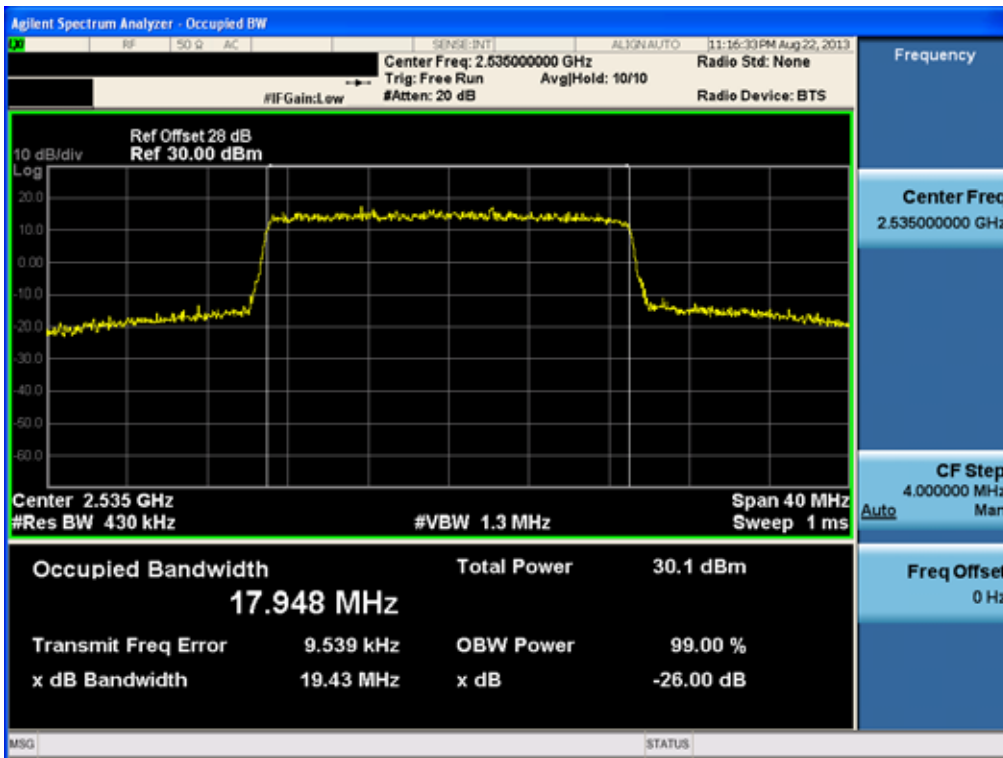

Occupied Bandwidth Plot (21100 ch_20 MHz_16-Q`AM_RB 100)

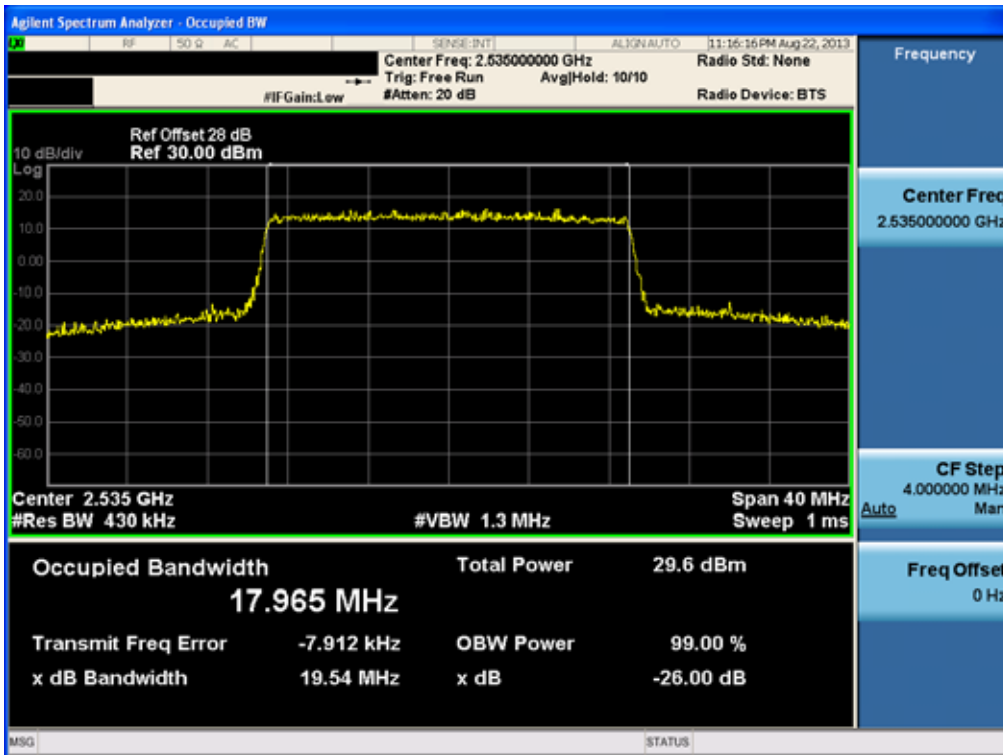

FCC CERTIFICATION REPORT

Test Report No. HCTR1308FR35	Date of Issue: September 06, 2013	EUT Type: GSM/WCDMA/LTE Phone with Bluetooth, WLAN(2.4GHz & 5GHz) and NFC	www.hct.co.kr FCC ID: ZNFD821
---------------------------------	--------------------------------------	--	--

PAR Plot (21100 ch_5 MHz_QPSK_RB 25)



PAR Plot (21100 ch_5 MHz_16-QAM_RB 25)



FCC CERTIFICATION REPORT

Test Report No. HCTR1308FR35	Date of Issue: September 06, 2013	EUT Type: GSM/WCDMA/LTE Phone with Bluetooth, WLAN(2.4GHz & 5GHz) and NFC	www.hct.co.kr FCC ID: ZNFD821
---------------------------------	--------------------------------------	--	--

PAR Plot (21100 ch_10 MHz_QPSK_RB 50)



PAR Plot (21100 ch_10 MHz_16-QAM_RB 50)



FCC CERTIFICATION REPORT

Test Report No. HCTR1308FR35	Date of Issue: September 06, 2013	EUT Type: GSM/WCDMA/LTE Phone with Bluetooth, WLAN(2.4GHz & 5GHz) and NFC	www.hct.co.kr FCC ID: ZNFD821
---------------------------------	--------------------------------------	--	--

PAR Plot (21100 ch_15 MHz_QPSK_RB 75)



PAR Plot (21100 ch_15 MHz_16-QAM_RB 75)



FCC CERTIFICATION REPORT

Test Report No. HCTR1308FR35	Date of Issue: September 06, 2013	EUT Type: GSM/WCDMA/LTE Phone with Bluetooth, WLAN(2.4GHz & 5GHz) and NFC	www.hct.co.kr FCC ID: ZNFD821
---------------------------------	--------------------------------------	--	--

PAR Plot (21100 ch_20 MHz_QPSK_RB 100)



PAR Plot (21100 ch_20 MHz_16-QAM_RB 100)



FCC CERTIFICATION REPORT

Test Report No. HCTR1308FR35	Date of Issue: September 06, 2013	EUT Type: GSM/WCDMA/LTE Phone with Bluetooth, WLAN(2.4GHz & 5GHz) and NFC	www.hct.co.kr FCC ID: ZNFD821
---------------------------------	--------------------------------------	--	--

Low Channel Edge Plot (5MHz QPSK - RB Size 25)



Mid Channel Edge Plot (5MHz QPSK - RB Size 25)

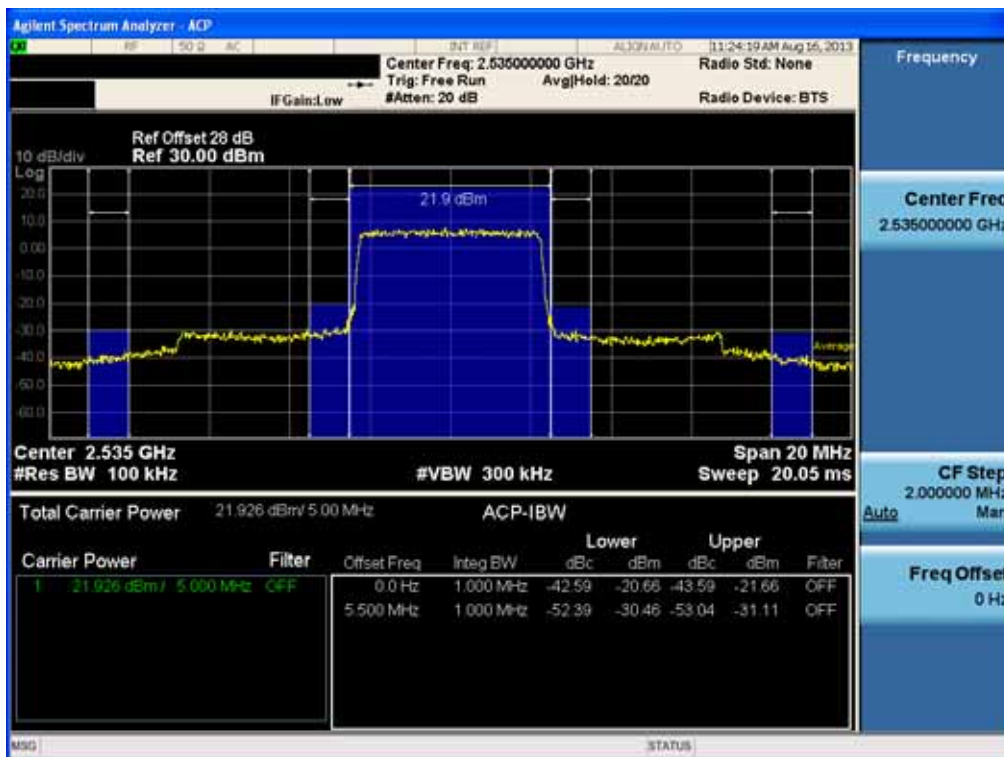

FCC CERTIFICATION REPORT

Test Report No.
HCTR1308FR35

Date of Issue:
September 06, 2013

EUT Type:
GSM/WCDMA/LTE Phone with Bluetooth, WLAN(2.4GHz & 5GHz) and NFC

www.hct.co.kr

FCC ID:
ZNF821

High Channel Edge Plot (5MHz QPSK - RB Size 25)

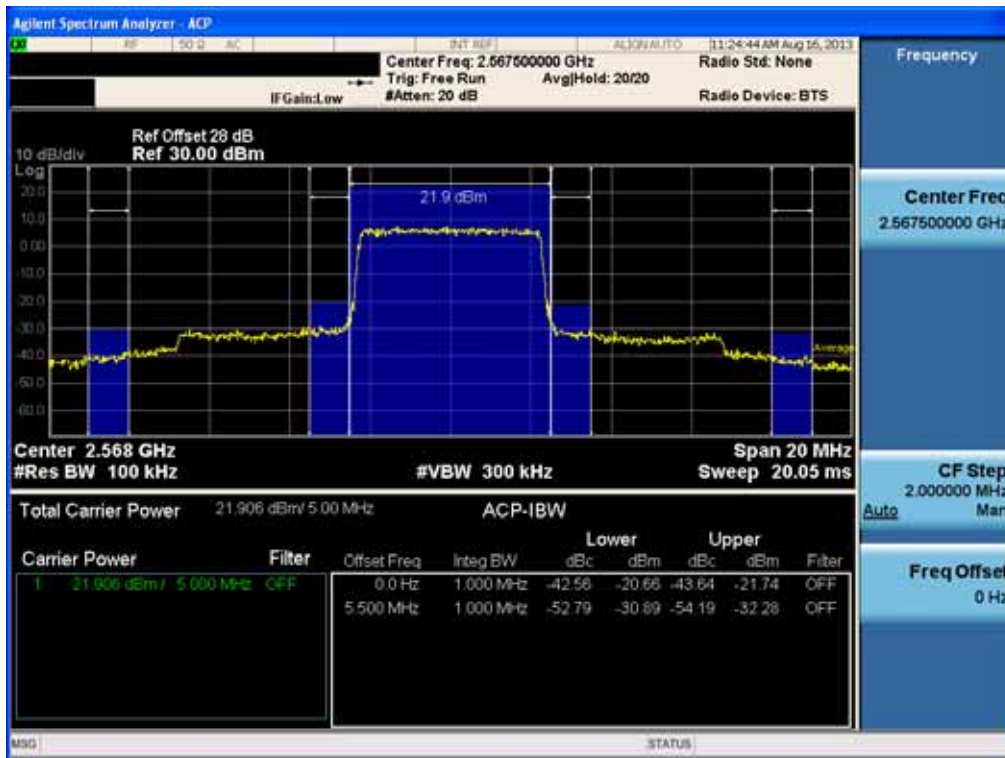

Low Channel Edge Plot (10MHz QPSK - RB Size 50)

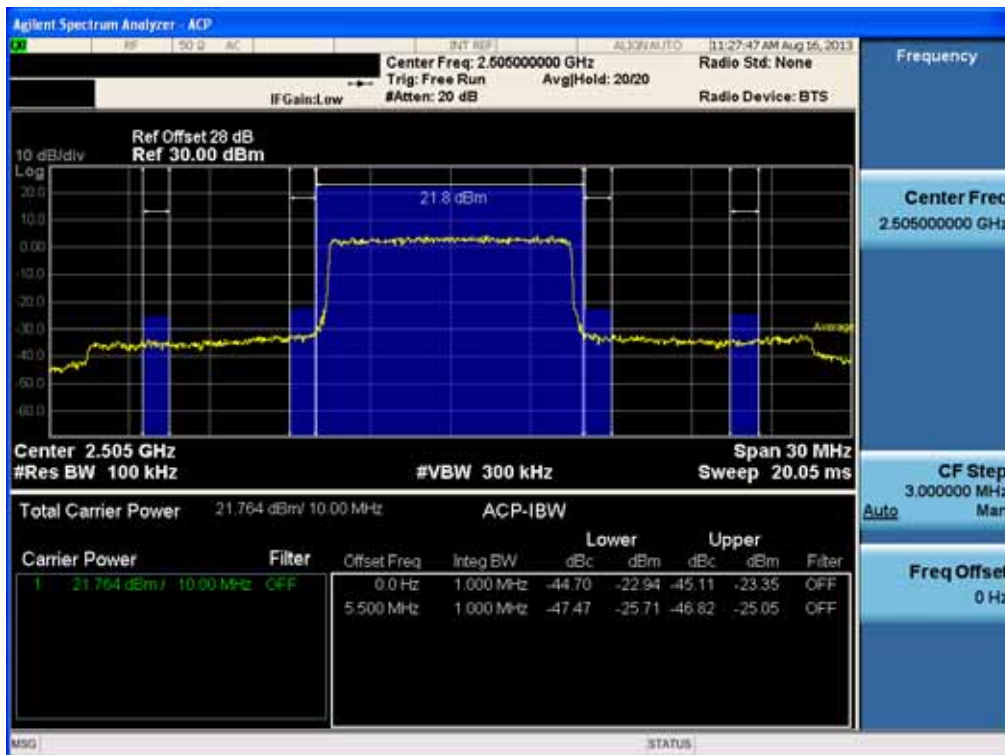

FCC CERTIFICATION REPORT

Test Report No. HCTR1308FR35	Date of Issue: September 06, 2013	EUT Type: GSM/WCDMA/LTE Phone with Bluetooth, WLAN(2.4GHz & 5GHz) and NFC	www.hct.co.kr FCC ID: ZNF0821
---------------------------------	--------------------------------------	--	--

Mid Channel Edge Plot (10MHz QPSK - RB Size 50)

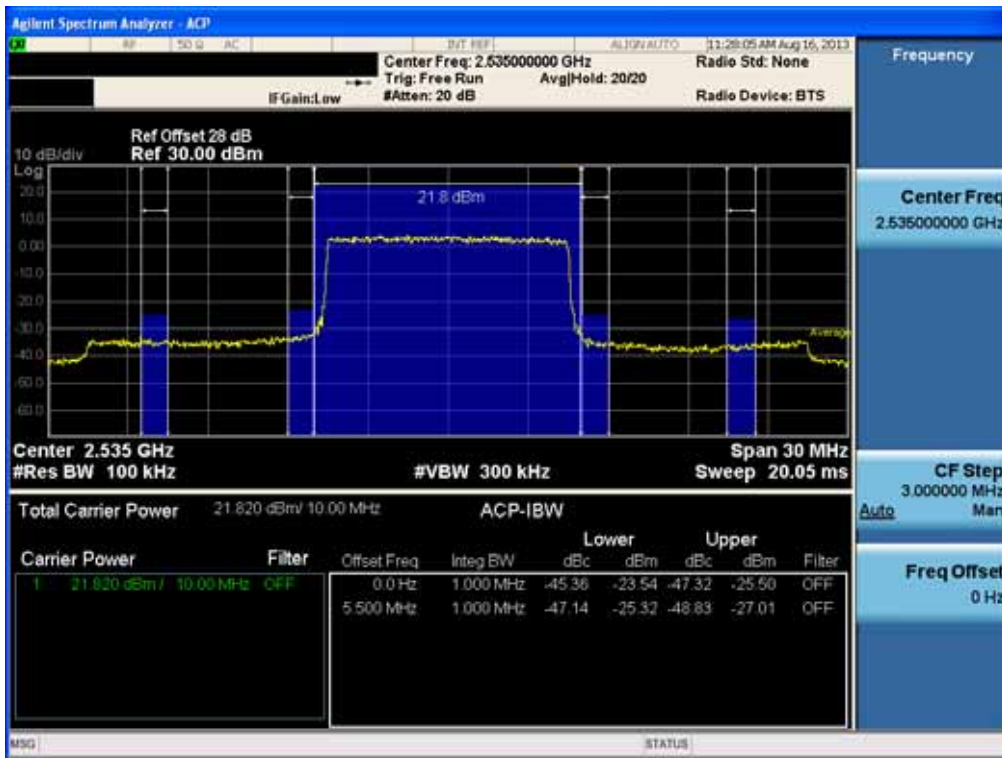

High Channel Edge Plot (10MHz QPSK - RB Size 50)



FCC CERTIFICATION REPORT

Test Report No. HCTR1308FR35	Date of Issue: September 06, 2013	EUT Type: GSM/WCDMA/LTE Phone with Bluetooth, WLAN(2.4GHz & 5GHz) and NFC	www.hct.co.kr FCC ID: ZNF821
---------------------------------	--------------------------------------	--	---

Low Channel Edge Plot (15MHz QPSK - RB Size 75)

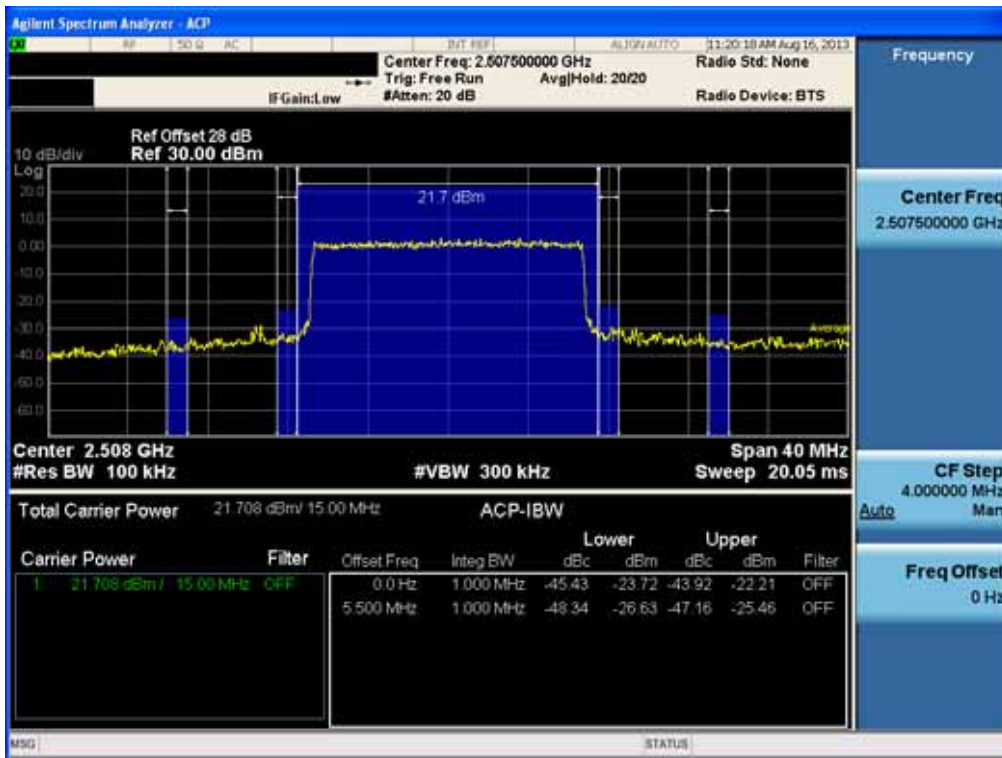

Mid Channel Edge Plot (15MHz QPSK - RB Size 75)

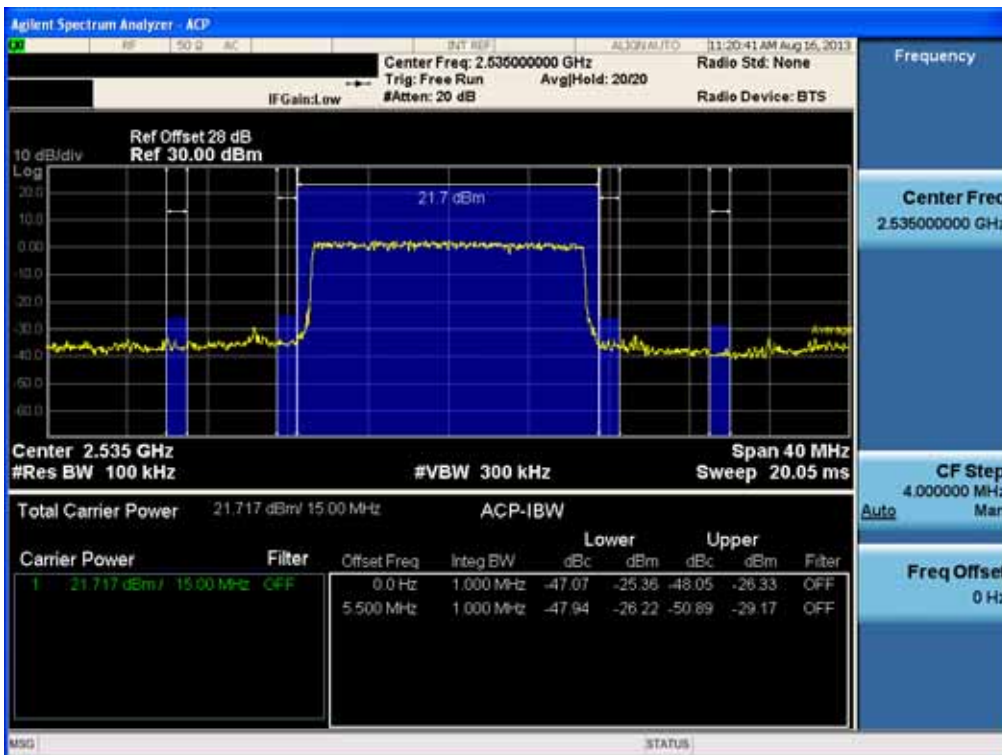

FCC CERTIFICATION REPORT

Test Report No. HCTR1308FR35	Date of Issue: September 06, 2013	EUT Type: GSM/WCDMA/LTE Phone with Bluetooth, WLAN(2.4GHz & 5GHz) and NFC	www.hct.co.kr FCC ID: ZNF821
---------------------------------	--------------------------------------	--	---

High Channel Edge Plot (15MHz QPSK - RB Size 75)

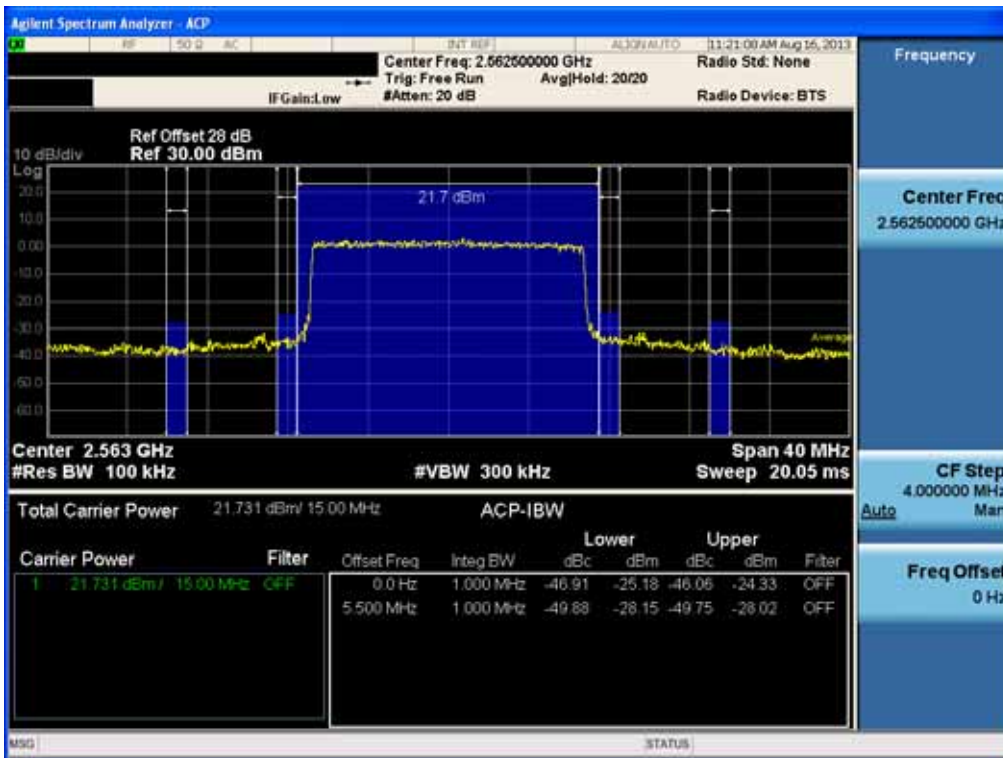

Low Channel Edge Plot (20MHz QPSK - RB Size 100)

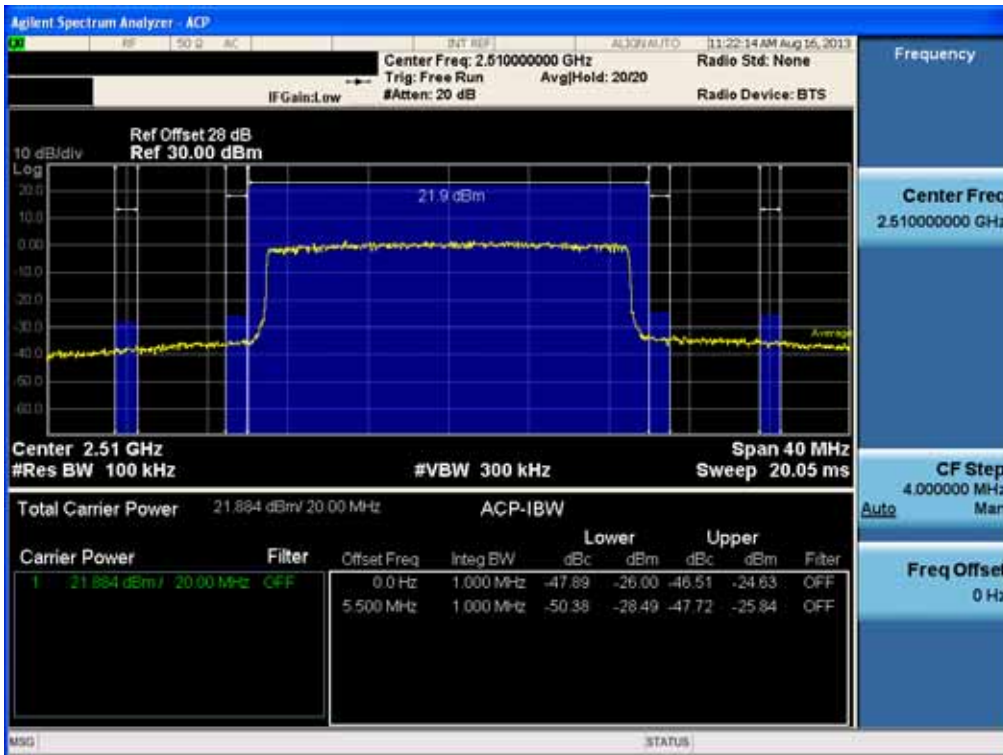

FCC CERTIFICATION REPORT

Test Report No.
HCTR1308FR35

Date of Issue:
September 06, 2013

EUT Type:
GSM/WCDMA/LTE Phone with Bluetooth, WLAN(2.4GHz & 5GHz) and NFC

www.hct.co.kr

FCC ID:
ZNF821

Mid Channel Edge Plot (20MHz QPSK - RB Size 100)

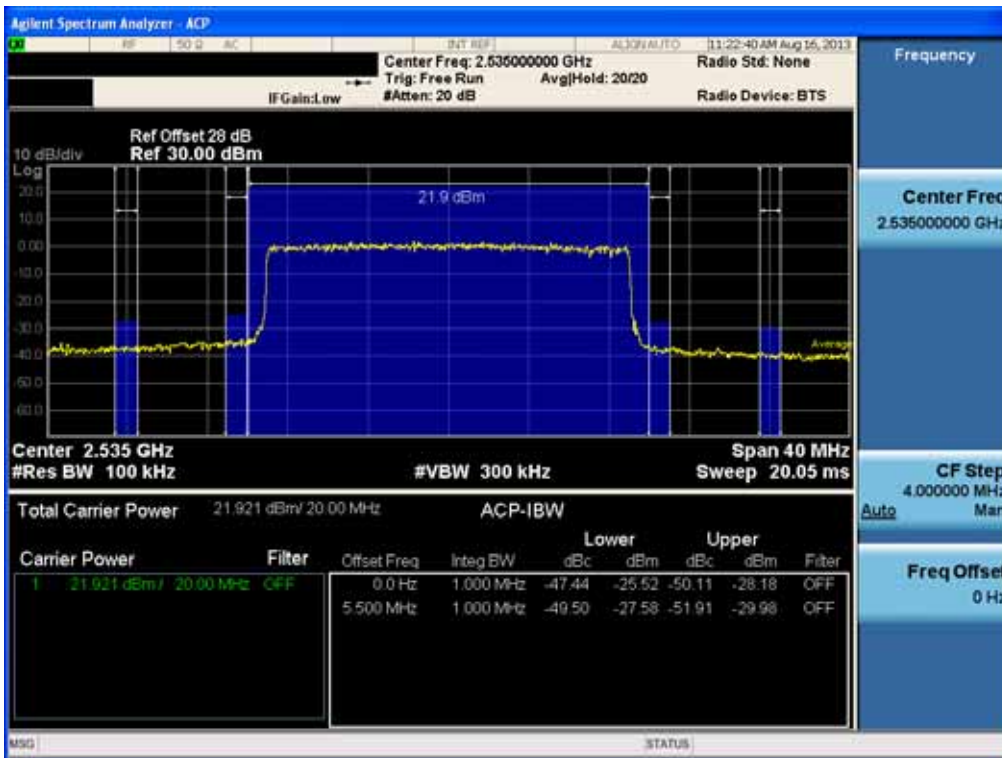

High Channel Edge Plot (20MHz QPSK - RB Size 100)

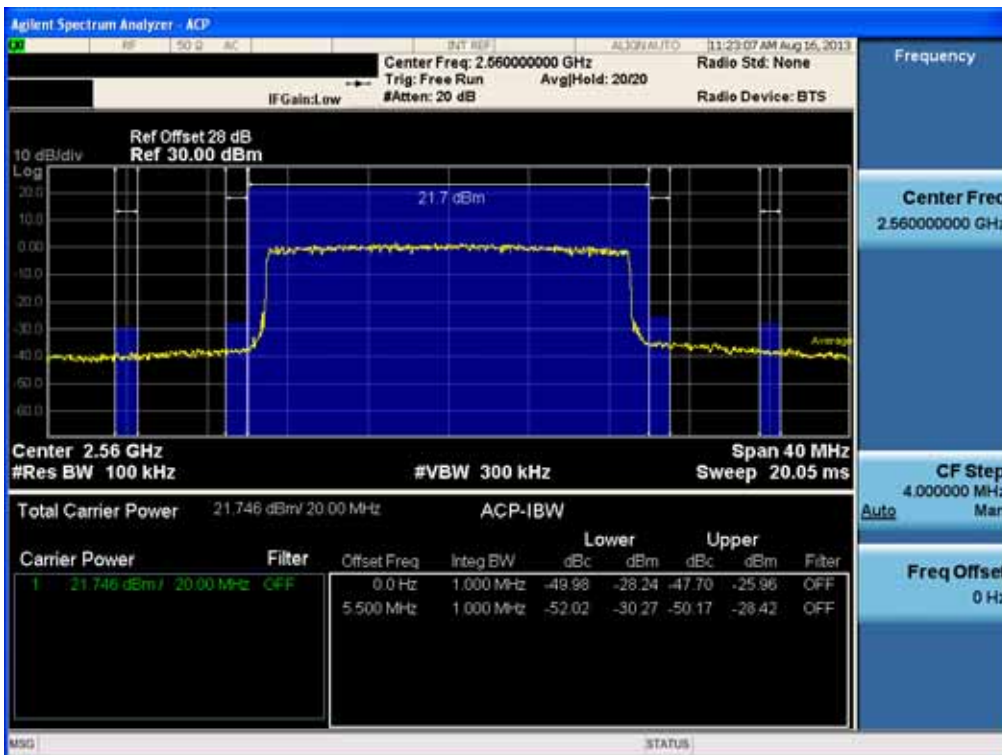

FCC CERTIFICATION REPORT

Test Report No. HCTR1308FR35	Date of Issue: September 06, 2013	EUT Type: GSM/WCDMA/LTE Phone with Bluetooth, WLAN(2.4GHz & 5GHz) and NFC	www.hct.co.kr FCC ID: ZNF0821
---------------------------------	--------------------------------------	--	--

Conducted Spurious Plot_1 (20775 ch_5 MHz_QPSK_RB 1_0) -1



Conducted Spurious Plot_2 (20775 ch_5 MHz_QPSK_RB 1_0) -2

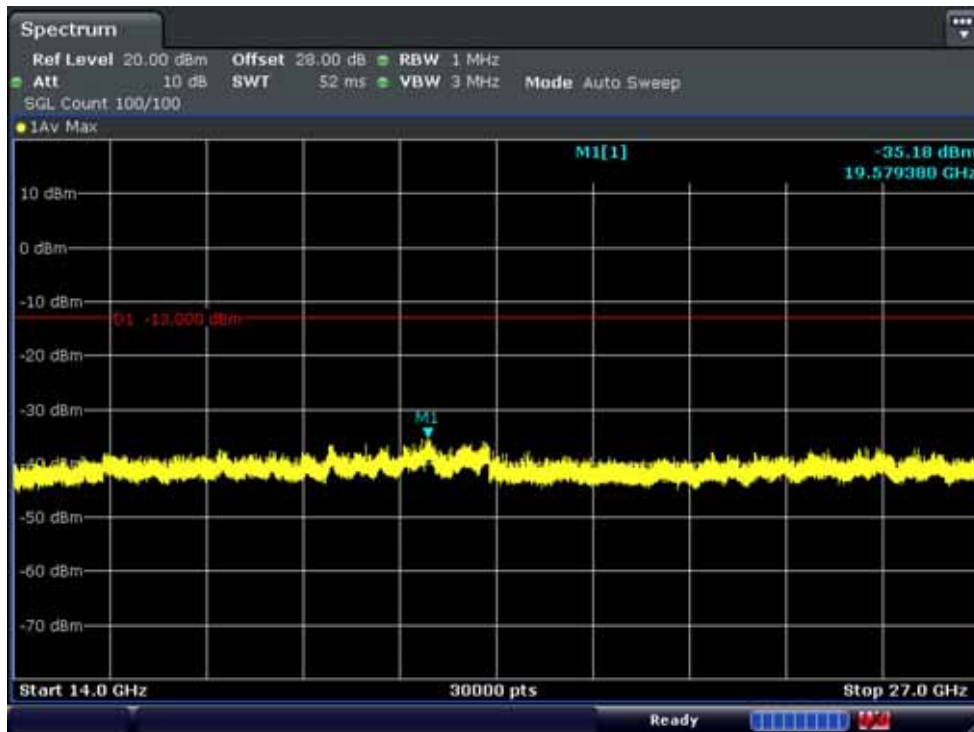

FCC CERTIFICATION REPORT

FCC CERTIFICATION REPORT			www.hct.co.kr
Test Report No. HCTR1308FR35	Date of Issue: September 06, 2013	EUT Type: GSM/WCDMA/LTE Phone with Bluetooth, WLAN(2.4GHz & 5GHz) and NFC	FCC ID: ZNF0821

Conducted Spurious Plot_1 (21100 ch_5 MHz_QPSK_RB 1_0) -1



Conducted Spurious Plot_2 (21100 ch_5 MHz_QPSK_RB 1_0) -2



FCC CERTIFICATION REPORT

Test Report No. HCTR1308FR35	Date of Issue: September 06, 2013	EUT Type: GSM/WCDMA/LTE Phone with Bluetooth, WLAN(2.4GHz & 5GHz) and NFC	www.hct.co.kr FCC ID: ZNFD821
---------------------------------	--------------------------------------	--	--

Conducted Spurious Plot_1 (21425 ch_5 MHz_QPSK_RB 1_0) -1



Conducted Spurious Plot_2 (21425 ch_5 MHz_QPSK_RB 1_0) -2

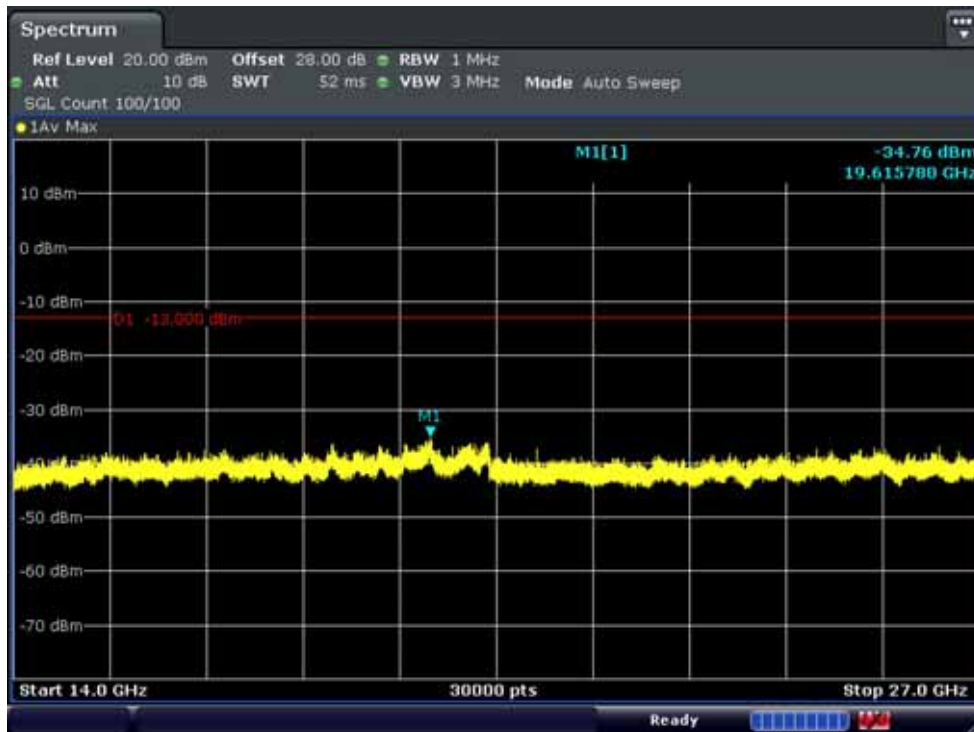

FCC CERTIFICATION REPORT

Test Report No. HCTR1308FR35	Date of Issue: September 06, 2013	EUT Type: GSM/WCDMA/LTE Phone with Bluetooth, WLAN(2.4GHz & 5GHz) and NFC	www.hct.co.kr FCC ID: ZNFD821
---------------------------------	--------------------------------------	--	--

Conducted Spurious Plot_1 (20800 ch_10 MHz_QPSK_RB 1_0) -1



Conducted Spurious Plot_2 (20800 ch_10 MHz_QPSK_RB 1_0) -2



FCC CERTIFICATION REPORT

Test Report No. HCTR1308FR35	Date of Issue: September 06, 2013	EUT Type: GSM/WCDMA/LTE Phone with Bluetooth, WLAN(2.4GHz & 5GHz) and NFC	www.hct.co.kr FCC ID: ZNFD821
---------------------------------	--------------------------------------	--	--

Conducted Spurious Plot_1 (21100 ch_10 MHz_QPSK_RB 1_0) -1

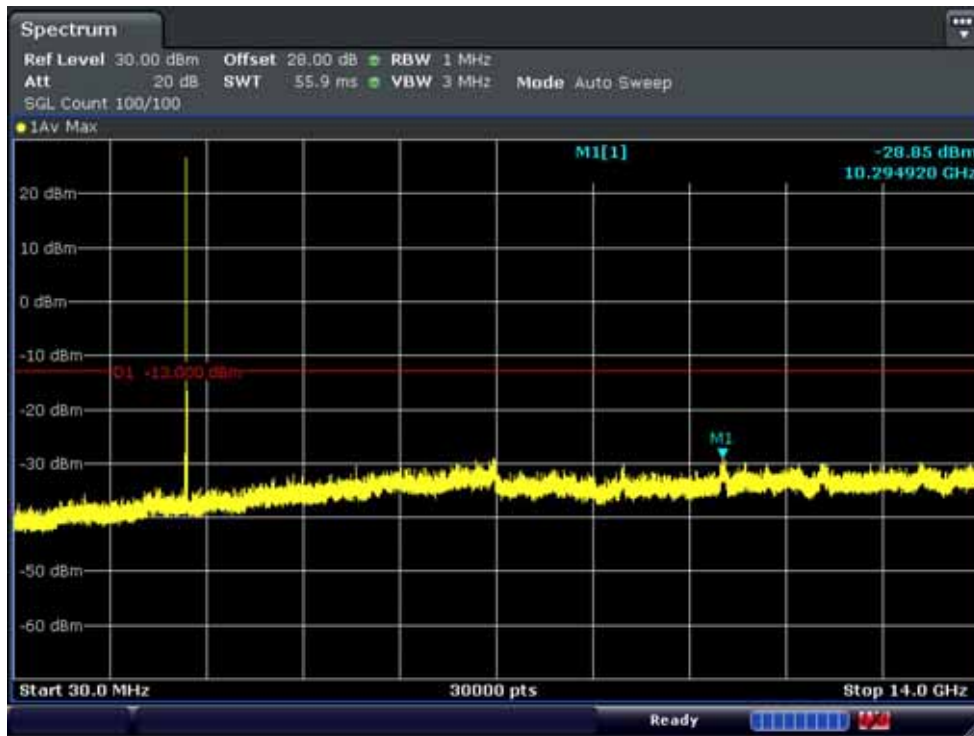

Conducted Spurious Plot_2 (21100 ch_10 MHz_QPSK_RB 1_0) -2

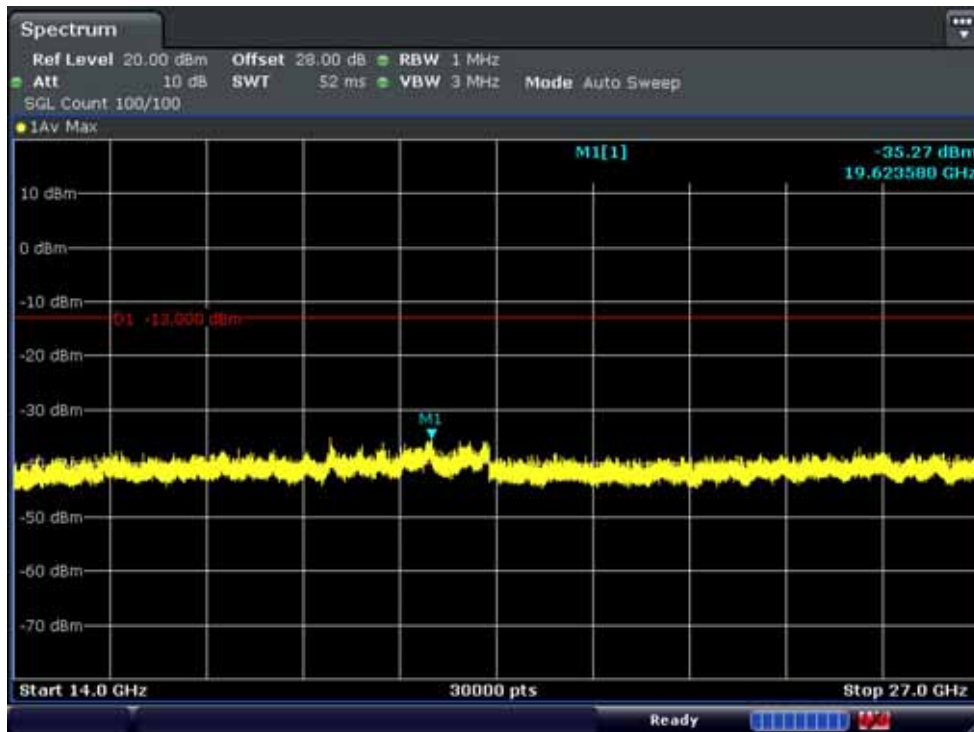

FCC CERTIFICATION REPORT

FCC CERTIFICATION REPORT			www.hct.co.kr
Test Report No. HCTR1308FR35	Date of Issue: September 06, 2013	EUT Type: GSM/WCDMA/LTE Phone with Bluetooth, WLAN(2.4GHz & 5GHz) and NFC	FCC ID: ZNF0821

Conducted Spurious Plot_1 (21400 ch_10 MHz_QPSK_RB 1_0) -1



Conducted Spurious Plot_2 (21400 ch_10 MHz_QPSK_RB 1_0) -2

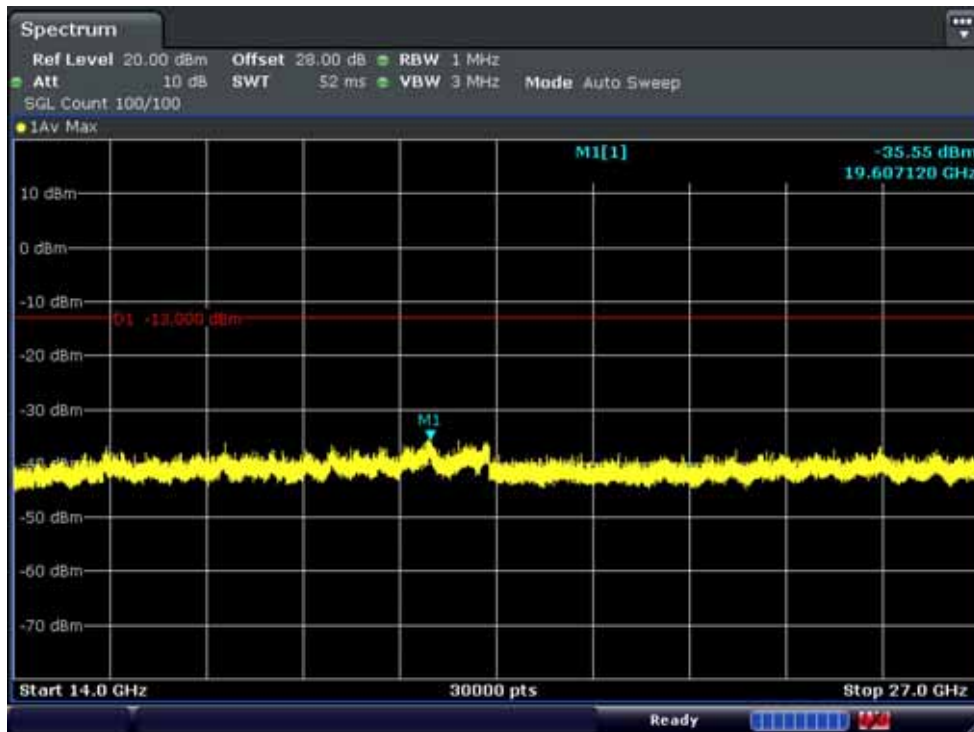

FCC CERTIFICATION REPORT

FCC CERTIFICATION REPORT			www.hct.co.kr
Test Report No. HCTR1308FR35	Date of Issue: September 06, 2013	EUT Type: GSM/WCDMA/LTE Phone with Bluetooth, WLAN(2.4GHz & 5GHz) and NFC	FCC ID: ZNFD821

Conducted Spurious Plot_1 (20825 ch_15 MHz_QPSK_RB 1_0) -1



Conducted Spurious Plot_2 (20825 ch_15 MHz_QPSK_RB 1_0) -2

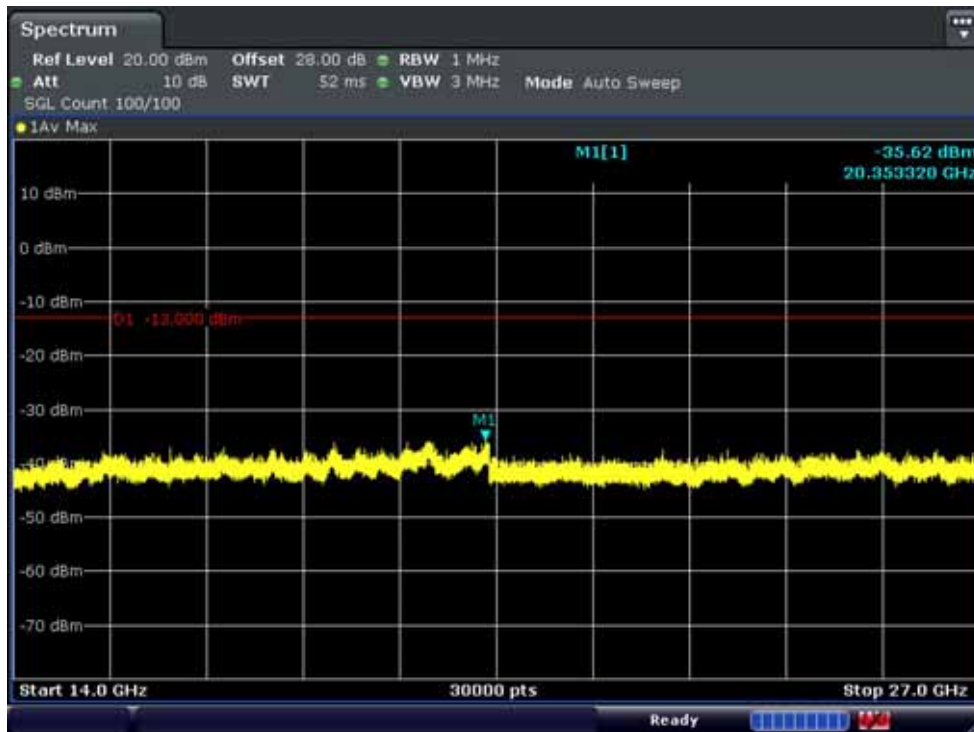

FCC CERTIFICATION REPORT

Test Report No. HCTR1308FR35	Date of Issue: September 06, 2013	EUT Type: GSM/WCDMA/LTE Phone with Bluetooth, WLAN(2.4GHz & 5GHz) and NFC	www.hct.co.kr FCC ID: ZNFD821
---------------------------------	--------------------------------------	--	--

Conducted Spurious Plot_1 (21100 ch_15 MHz_QPSK_RB 1_0) -1



Conducted Spurious Plot_2 (21100 ch_15 MHz_QPSK_RB 1_0) -2

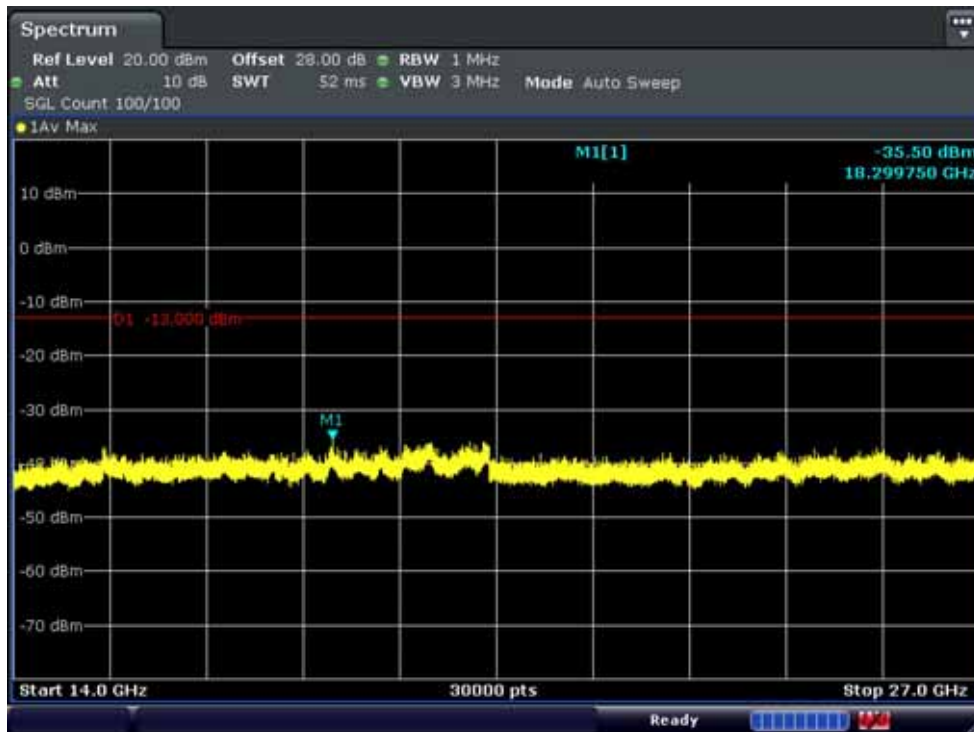

FCC CERTIFICATION REPORT

Test Report No. HCTR1308FR35	Date of Issue: September 06, 2013	EUT Type: GSM/WCDMA/LTE Phone with Bluetooth, WLAN(2.4GHz & 5GHz) and NFC	www.hct.co.kr FCC ID: ZNFD821
---------------------------------	--------------------------------------	--	--

Conducted Spurious Plot_1 (21375 ch_15 MHz_QPSK_RB 1_0) -1



Conducted Spurious Plot_2 (21375 ch_15 MHz_QPSK_RB 1_0) -2



FCC CERTIFICATION REPORT

Test Report No. HCTR1308FR35	Date of Issue: September 06, 2013	EUT Type: GSM/WCDMA/LTE Phone with Bluetooth, WLAN(2.4GHz & 5GHz) and NFC	www.hct.co.kr FCC ID: ZNFD821
---------------------------------	--------------------------------------	--	--

Conducted Spurious Plot_1 (20850 ch_20 MHz_QPSK_RB 1_0) -1



Conducted Spurious Plot_2 (20850 ch_20 MHz_QPSK_RB 1_0) -2

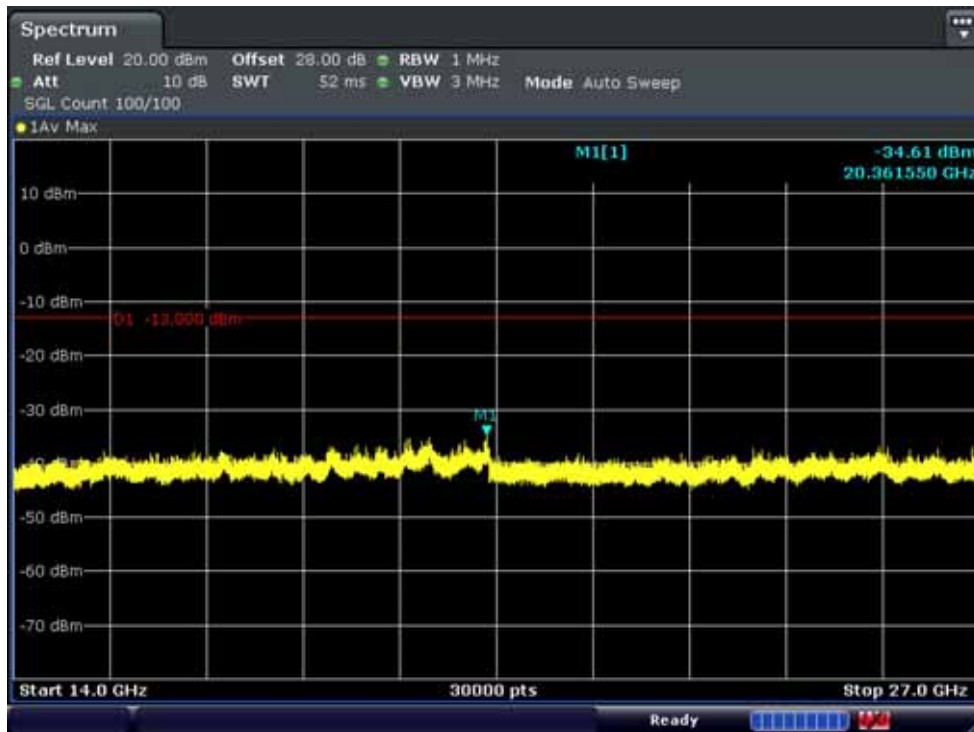

FCC CERTIFICATION REPORT

Test Report No. HCTR1308FR35	Date of Issue: September 06, 2013	EUT Type: GSM/WCDMA/LTE Phone with Bluetooth, WLAN(2.4GHz & 5GHz) and NFC	www.hct.co.kr FCC ID: ZNFD821
---------------------------------	--------------------------------------	--	--

Conducted Spurious Plot_1 (21100 ch_20 MHz_QPSK_RB 1_0) -1



Conducted Spurious Plot_2 (21100 ch_20 MHz_QPSK_RB 1_0) -2

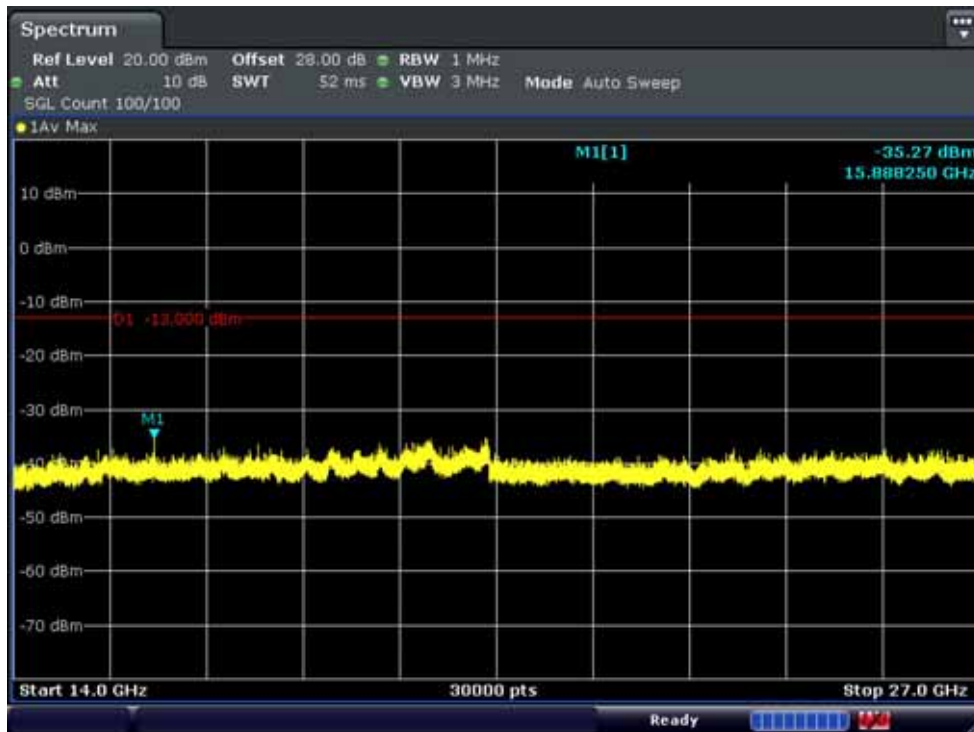

FCC CERTIFICATION REPORT

Test Report No. HCTR1308FR35	Date of Issue: September 06, 2013	EUT Type: GSM/WCDMA/LTE Phone with Bluetooth, WLAN(2.4GHz & 5GHz) and NFC	www.hct.co.kr FCC ID: ZNF821
---------------------------------	--------------------------------------	--	---

Conducted Spurious Plot_1 (21350 ch_20 MHz_QPSK_RB 1_0) -1



Conducted Spurious Plot_2 (21350 ch_20 MHz_QPSK_RB 1_0) -2

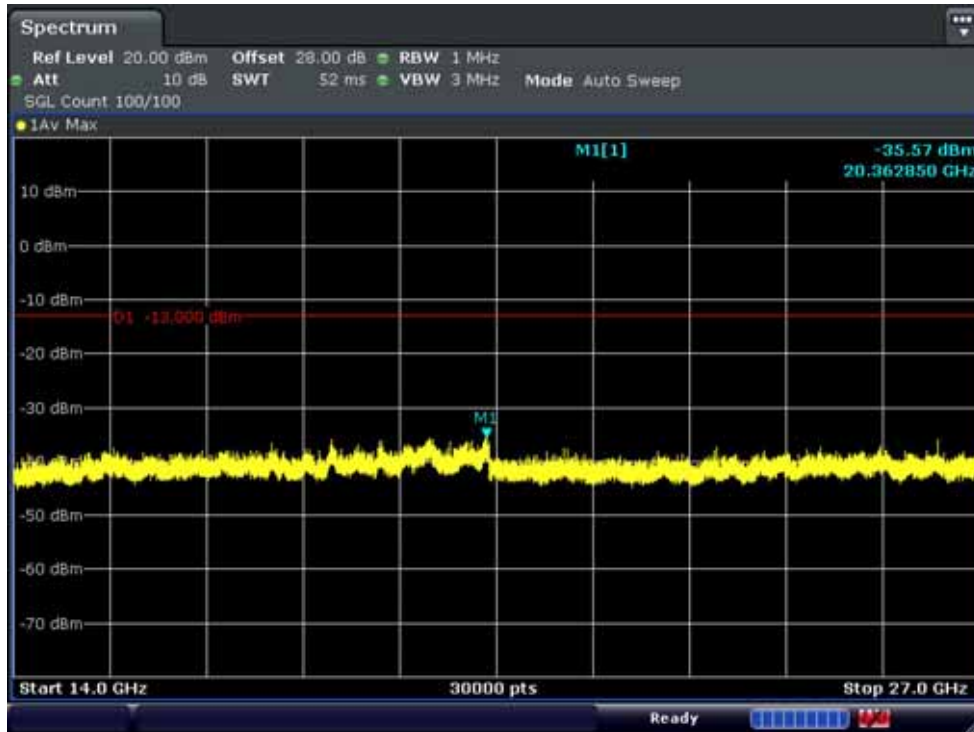

FCC CERTIFICATION REPORT

Test Report No. HCTR1308FR35	Date of Issue: September 06, 2013	EUT Type: GSM/WCDMA/LTE Phone with Bluetooth, WLAN(2.4GHz & 5GHz) and NFC	www.hct.co.kr FCC ID: ZNFD821
---------------------------------	--------------------------------------	--	--