

FCC RF Test Report

APPLICANT : LG Electronics Inc.
EQUIPMENT : Mobile Phone
BRAND NAME : LG
MODEL NAME : LG-D805, LG-D806
FCC ID : ZNFD805
STANDARD : FCC Part 15 Subpart C §15.247
CLASSIFICATION : (DTS) Digital Transmission System

The product was received on Jun. 28, 2013 and completely tested on Jul. 18, 2013. We, SPORTON INTERNATIONAL INC., would like to declare that the tested sample has been evaluated in accordance with the procedures and shown the compliance with the applicable technical standards.

The test results in this report apply exclusively to the tested model / sample. Without written approval of SPORTON INTERNATIONAL INC., the test report shall not be reproduced except in full.



Reviewed by: Joseph Lin / Supervisor

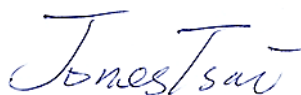

Approved by: Jones Tsai / Manager



SPORTON INTERNATIONAL INC.

No. 52, Hwa Ya 1st Rd., Hwa Ya Technology Park, Kwei-Shan Hsiang, Tao Yuan Hsien, Taiwan, R.O.C.



TABLE OF CONTENTS

REVISION HISTORY 3

SUMMARY OF TEST RESULT 4

1 GENERAL DESCRIPTION..... 5

 1.1 Applicant 5

 1.2 Manufacturer..... 5

 1.3 Feature of Equipment Under Test 5

 1.4 Product Specification of Equipment Under Test..... 5

 1.5 Modification of EUT 6

 1.6 Testing Site..... 6

 1.7 Applied Standards 6

2 TEST CONFIGURATION OF EQUIPMENT UNDER TEST..... 7

 2.1 Descriptions of Test Mode 7

 2.2 Test Mode..... 8

 2.3 Connection Diagram of Test System..... 9

 2.4 Support Unit used in test configuration and system 10

 2.5 Description of RF Function Operation Test Setup..... 10

 2.6 Measurement Results Explanation Example..... 11

3 TEST RESULT 12

 3.1 6dB Bandwidth Measurement 12

 3.2 Peak Output Power Measurement 15

 3.3 Power Spectral Density Measurement 17

 3.4 Conducted Band Edges and Spurious Emission Measurement 23

 3.5 Radiated Band Edges and Spurious Emission Measurement 32

 3.6 AC Conducted Emission Measurement..... 47

 3.7 Antenna Requirements 53

4 LIST OF MEASURING EQUIPMENT..... 54

5 UNCERTAINTY OF EVALUATION..... 55

APPENDIX A. SETUP PHOTOGRAPHS



REVISION HISTORY

REPORT NO.	VERSION	DESCRIPTION	ISSUED DATE
FR362801B	Rev. 01	Initial issue of report	Aug. 09, 2013



SUMMARY OF TEST RESULT

Report Section	FCC Rule	IC Rule	Description	Limit	Result	Remark
3.1	15.247(a)(2)	RSS-210 A8.2(a)	6dB Bandwidth	$\geq 0.5\text{MHz}$	Pass	-
3.2	15.247(b)(1)	RSS-210 A8.1(b)	Peak Output Power	$\leq 30\text{dBm}$	Pass	-
3.3	15.247(e)	RSS-210 A8.2(b)	Power Spectral Density	$\leq 8\text{dBm}$	Pass	-
3.4	15.247(d)	RSS-210 A8.5	Conducted Band Edges and Spurious Emission	$\leq 20\text{dBc}$	Pass	-
3.5	15.247(d)	RSS-210 A8.5	Radiated Band Edges and Spurious Emission	15.209(a) & 15.247(d)	Pass	Under limit 6.92 dB at 42.150 MHz
3.6	15.207	RSS-210 Gen 7.2.2	AC Conducted Emission	15.207(a)	Pass	Under limit 12.70 dB at 2.438 MHz
3.7	15.203 & 15.247(b)	RSS-210 A8.4	Antenna Requirement	N/A	Pass	-

1 General Description

1.1 Applicant

LG Electronics Inc.

60-39, Kasan-dong, Kumchon-gu, Seoul 135-801, Korea

1.2 Manufacturer

LG Electronics Inc.

60-39, Kasan-dong, Kumchon-gu, Seoul 135-801, Korea

1.3 Feature of Equipment Under Test

Product Feature	
Equipment	Mobile Phone
Brand Name	LG
Model Name	LG-D805, LG-D806
FCC ID	ZNFD805
EUT supports Radios application	GSM/EGPRS/WCDMA/HSPA/LTE/ WLAN 2.4GHz 802.11b/g/n/ac WLAN 5GHz 802.11a/n/ac/ Bluetooth 3.0/4.0+LE / NFC
HW Version	Rev.d
SW Version	D80508a
EUT Stage	Production Unit

Remark: The above EUT's information was declared by manufacturer. Please refer to the specifications or user's manual for more detailed description.

1.4 Product Specification of Equipment Under Test

Product Specification subjective to this standard	
Tx/Rx Frequency Range	2402 MHz ~ 2480 MHz
Number of Channels	40
Carrier Frequency of Each Channel	40 Channel(37 hopping + 3 advertising channel)
Maximum Output Power to Antenna	4.69 dBm (0.0029 W)
Antenna Type	PIFA Antenna type with gain -1.99 dBi
Type of Modulation	Bluetooth 4.0 - LE : GFSK

1.5 Modification of EUT

No modifications are made to the EUT during all test items.

1.6 Testing Site

Test Site	SPORTON INTERNATIONAL INC.			
Test Site Location	No. 52, Hwa Ya 1 st Rd., Hwa Ya Technology Park, Kwei-Shan Hsiang, Tao Yuan Hsien, Taiwan, R.O.C. TEL: +886-3-3273456 / FAX: +886-3-3284978			
Test Site No.	Sporton Site No.			FCC/IC Registration No.
	TH02-HY	CO05-HY	03CH08-HY	636805/4086B-2

The test site complies with ANSI C63.4 2003 requirement.

1.7 Applied Standards

According to the specifications of the manufacturer, the EUT must comply with the requirements of the following standards:

- FCC Part 15 Subpart C §15.247
- FCC KDB Publication No. 558074 D01 DTS Meas. Guidance v03r01
- ANSI C63.4-2003

Remark:

1. All test items were verified and recorded according to the standards and without any deviation during the test.
2. This EUT has also been tested and complied with the requirements of FCC Part 15, Subpart B, recorded in a separate test report.

2 Test Configuration of Equipment Under Test

2.1 Descriptions of Test Mode

The RF output power was recorded in the following table:

Channel	Frequency	Bluetooth 4.0 – LE RF Output Power	
		Data Rate / Modulation	
		GFSK	
		1Mbps	
Ch00	2402MHz	4.62 dBm	
Ch19	2440MHz	4.66 dBm	
Ch39	2480MHz	4.69 dBm	

- a. The EUT has been associated with peripherals and configuration operated in a manner tended to maximize its emission characteristics in a typical application. Frequency range investigated: conduction (150 kHz to 30 MHz), radiation (9 kHz to the 10th harmonic of the highest fundamental frequency or to 40 GHz, whichever is lower). Pre-scanned tests, X, Y, Z in three orthogonal panels to determine the final configuration (X plane as worst plane) from all possible combinations.
- b. AC power line Conducted Emission was tested under maximum output power.



2.2 Test Mode

The following summary table is showing all test modes to demonstrate in compliance with the standard.

Summary table of Test Cases	
Test Item	Data Rate / Modulation
	Bluetooth 4.0 – LE / GFSK
Conducted TCs	Mode 1: Bluetooth Tx CH00_2402 MHz_1Mbps
	Mode 2: Bluetooth Tx CH19_2440 MHz_1Mbps
	Mode 3: Bluetooth Tx CH39_2480 MHz_1Mbps
Radiated TCs	Mode 1: Bluetooth Tx CH00_2402 MHz_1Mbps
	Mode 2: Bluetooth Tx CH19_2440 MHz_1Mbps
	Mode 3: Bluetooth Tx CH39_2480 MHz_1Mbps
AC Conducted Emission	Mode 1 :GSM850 Idle + Bluetooth Link + WLAN (2.4GHz) Link + MP3 + Earphone + USB Cable (Charging from Adapter)

2.3 Connection Diagram of Test System

<Bluetooth 4.0 – LE Tx Mode>

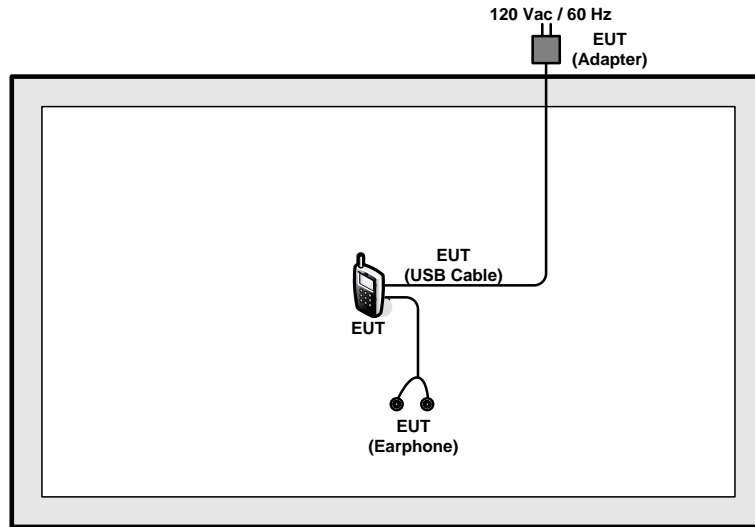

<AC Conducted Emission Mode>

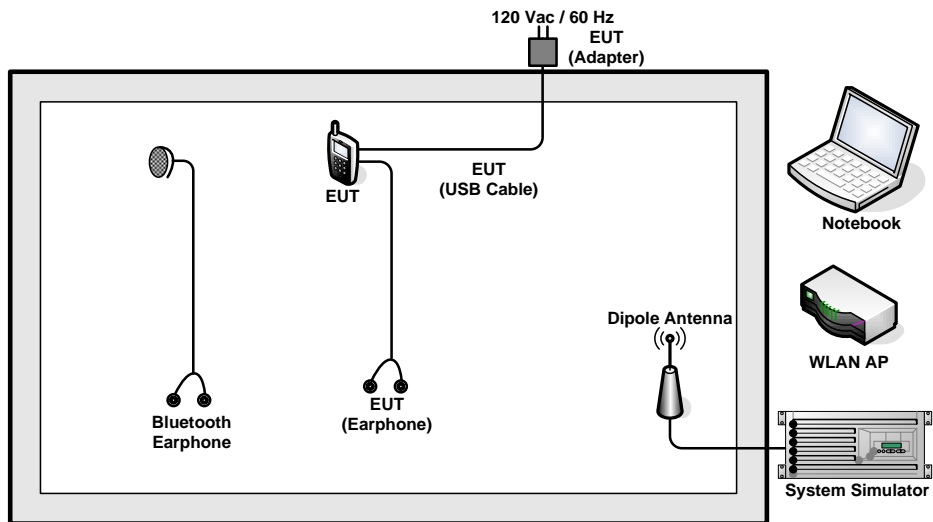

2.4 Support Unit used in test configuration and system

Item	Equipment	Trade Name	Model Name	FCC ID	Data Cable	Power Cord
1.	System Simulator	R&S	CMU 200	N/A	N/A	Unshielded, 1.8 m
2.	WLAN AP	D-Link	DIR-628	KA2DIR628A2	N/A	Unshielded, 1.8 m
3.	Notebook	DELL	Latitude E6320	FCC DoC	N/A	AC I/P: Unshielded, 1.2 m DC O/P: Shielded, 1.8 m
4.	Bluetooth Earphone	Sony Ericsson	MW600	PY7DDA-2029	N/A	N/A
5.	SD Card	SanDisk	MicroSD HC	FCC DoC	N/A	N/A

2.5 Description of RF Function Operation Test Setup

For Bluetooth test items, an engineering test program (SW D80508a) was provided and enabled to make EUT continuous transmit/receive.



2.6 Measurement Results Explanation Example

For all conducted test items:

The offset level is set in the spectrum analyzer to compensate the RF cable loss and attenuator factor between EUT conducted output port and spectrum analyzer. With the offset compensation, the spectrum analyzer reading level is exactly the EUT RF output level.

Example :

The spectrum analyzer offset is derived from RF cable loss and attenuator factor.

Offset = RF cable loss + attenuator factor.

Following shows an offset computation example with cable loss 4.2 dB and 10dB attenuator.

$$\begin{aligned} \text{Offset(dB)} &= \text{RF cable loss(dB)} + \text{attenuator factor(dB)}. \\ &= 4.2 + 10 = 14.2 \text{ (dB)} \end{aligned}$$

3 Test Result

3.1 6dB Bandwidth Measurement

3.1.1 Limit of 6dB Bandwidth

The minimum 6 dB bandwidth shall be at least 500 kHz.

3.1.2 Measuring Instruments

See list of measuring instruments of this test report.

3.1.3 Test Procedures

1. The testing follows FCC KDB Publication No. 558074 D01 DTS Meas. Guidance v03r01.
2. The RF output of EUT was connected to the spectrum analyzer by RF cable and attenuator. The path loss was compensated to the results for each measurement.
3. Set to the maximum power setting and enable the EUT transmit continuously.
4. Make the measurement with the spectrum analyzer's resolution bandwidth (RBW) = 100 kHz. Set the Video bandwidth (VBW) = 300 kHz. In order to make an accurate measurement. The 6 dB bandwidth must be greater than 500 kHz.
5. Measure and record the results in the test report.

3.1.4 Test Setup

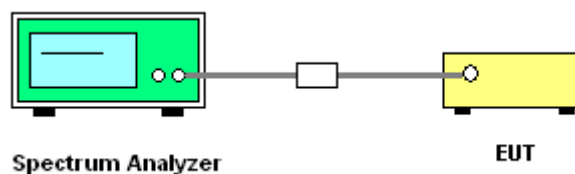



3.1.5 Test Result of 6dB Bandwidth

Test Mode :	Bluetooth 4.0 - LE	Temperature :	22~25°C
Test Engineer :	Coyote Lin	Relative Humidity :	51~55%

Channel	Frequency (MHz)	6dB Bandwidth (MHz)	6dB Bandwidth Min. Limit (MHz)	Pass/Fail
00	2402	0.711	0.5	Pass
19	2440	0.713	0.5	Pass
39	2480	0.710	0.5	Pass

6 dB Bandwidth Plot on Channel 00

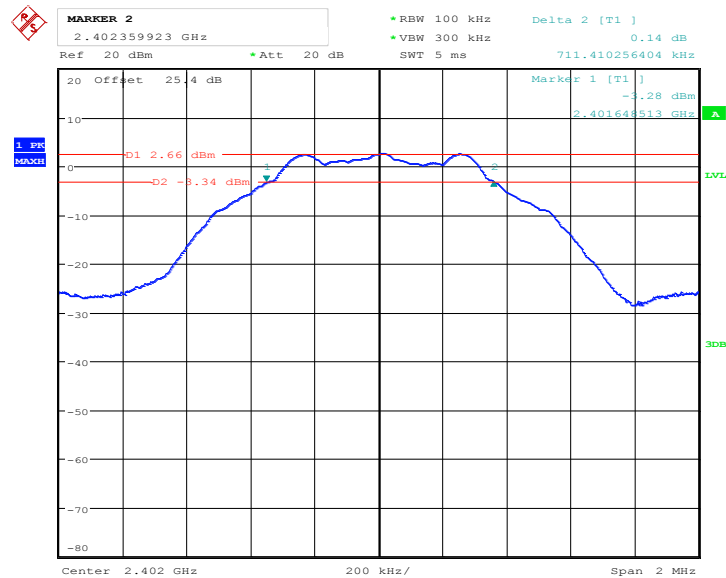

Date: 15.JUL.2013 09:08:07



6 dB Bandwidth Plot on Channel 19

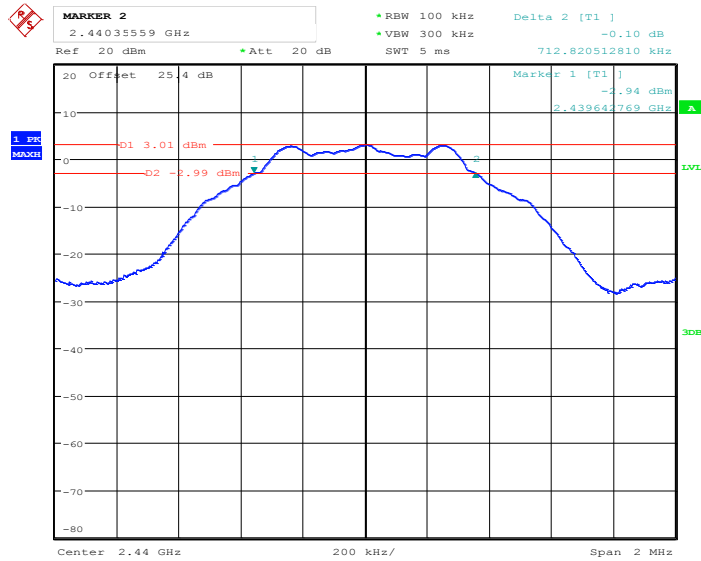

Date: 15.JUL.2013 09:13:03

6 dB Bandwidth Plot on Channel 39

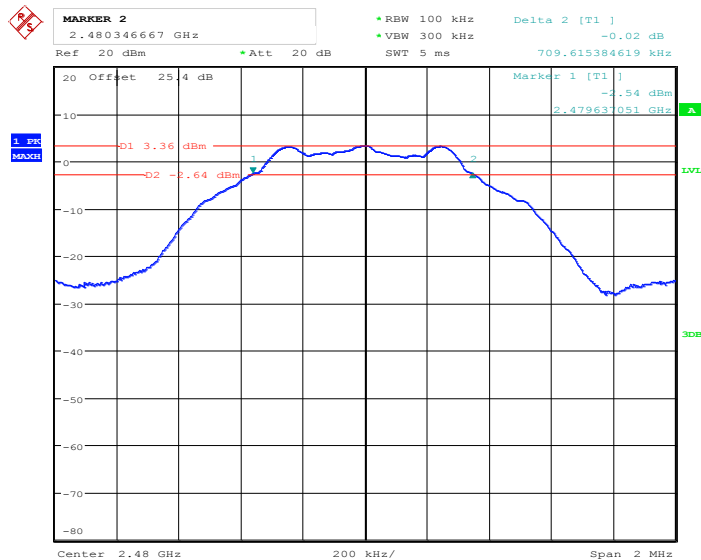

Date: 15.JUL.2013 09:17:30

3.2 Peak Output Power Measurement

3.2.1 Limit of Peak Output Power

For systems using digital modulation in the 2400-2483.5MHz, the limit for peak output power is 30dBm. If transmitting antenna of directional gain greater than 6dBi is used, the peak output power from the intentional radiator shall be reduced below the above stated value by the amount in dB that the directional gain of the antenna exceeds 6 dBi. In case of point-to-point operation, the limit has to be reduced by 1dB for every 3dB that the directional gain of the antenna exceeds 6dBi.

3.2.2 Measuring Instruments

See list of measuring instruments of this test report.

3.2.3 Test Procedures

1. The testing follows the Measurement Procedure of FCC KDB No. 558074 DTS D01 Meas. Guidance v03r01.
2. The RF output of EUT was connected to the power meter by RF cable and attenuator. The path loss was compensated to the results for each measurement.
3. Set to the maximum power setting and enable the EUT transmit continuously.
4. Measure the conducted output power and record the results in the test report.

3.2.4 Test Setup

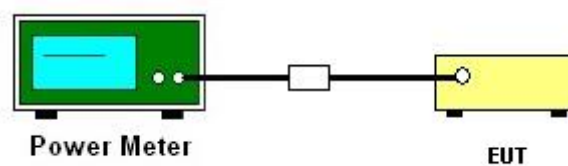



3.2.5 Test Result of Peak Output Power

Test Mode :	Bluetooth 4.0 - LE	Temperature :	22~25°C
Test Engineer :	Coyote Lin	Relative Humidity :	51~55%

Channel	Frequency (MHz)	RF Power (dBm)		
		GFSK	Max. Limits (dBm)	Pass/Fail
		1 Mbps		
00	2402	4.62	30.00	Pass
19	2440	4.66	30.00	Pass
39	2480	4.69	30.00	Pass

3.3 Power Spectral Density Measurement

3.3.1 Limit of Power Spectral Density

The peak power spectral density shall not be greater than 8dBm in any 3kHz band at any time interval of continuous transmission.

3.3.2 Measuring Instruments

See list of measuring instruments of this test report.

3.3.3 Test Procedures

1. The testing follows Measurement Procedure 10.2 Method PKPSD of FCC KDB Publication No. 558074 D01 DTS Meas. Guidance v03r01
2. The RF output of EUT was connected to the spectrum analyzer by RF cable and attenuator. The path loss was compensated to the results for each measurement.
3. Set to the maximum power setting and enable the EUT transmit continuously.
4. Make the measurement with the spectrum analyzer's resolution bandwidth (RBW) = 3 kHz. Video bandwidth VBW = 10 kHz In order to make an accurate measurement, set the span to 1.5 times DTS Channel Bandwidth. (6dB BW)
5. Detector = peak, Sweep time = auto couple, Trace mode = max hold, Allow trace to fully stabilize. Use the peak marker function to determine the maximum power level.
6. Measure and record the results in the test report.
7. The Measured power density (dBm)/ 100kHz is a reference level and used as 20dBc down limit line for Conducted Band Edges and Conducted Spurious Emission.

3.3.4 Test Setup

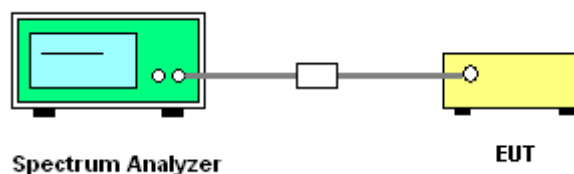



3.3.5 Test Result of Power Spectral Density

Test Mode :	Bluetooth 4.0 - LE	Temperature :	22~25°C
Test Engineer :	Coyote Lin	Relative Humidity :	51~55%

Channel	Frequency (MHz)	Power Density		Max. Limits (dBm/3kHz)	Pass/Fail
		PSD/100kHz (dBm)	PSD/3kHz (dBm)		
00	2402	2.59	-10.99	8	Pass
19	2440	2.96	-10.66	8	Pass
39	2480	3.34	-10.30	8	Pass

Note:

1. Measured power density (dBm) has offset with cable loss.
2. The Measured power density (dBm)/ 100kHz is reference level and used as 20dBc down for Conducted Band Edges and Conducted Spurious Emission limit line.



3.3.6 Test Result of Power Spectral Density Plots (100kHz)

PSD 100kHz Plot on Channel 00

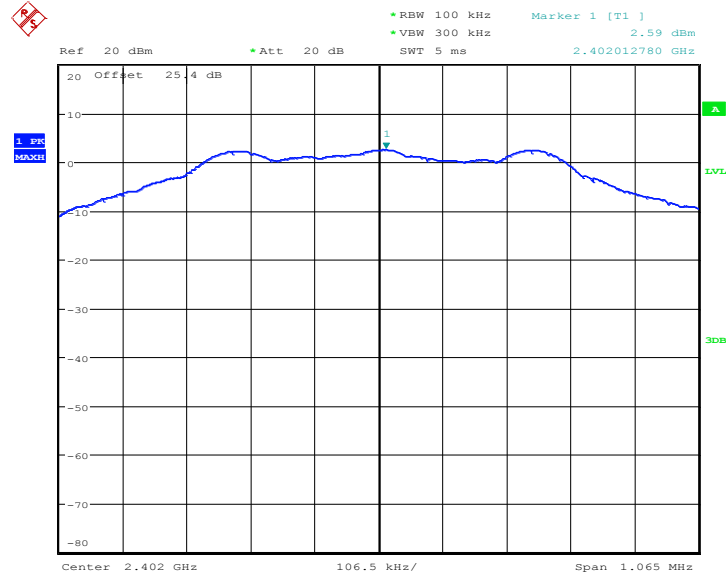

Date: 15.JUL.2013 09:09:44



PSD 100kHz Plot on Channel 19

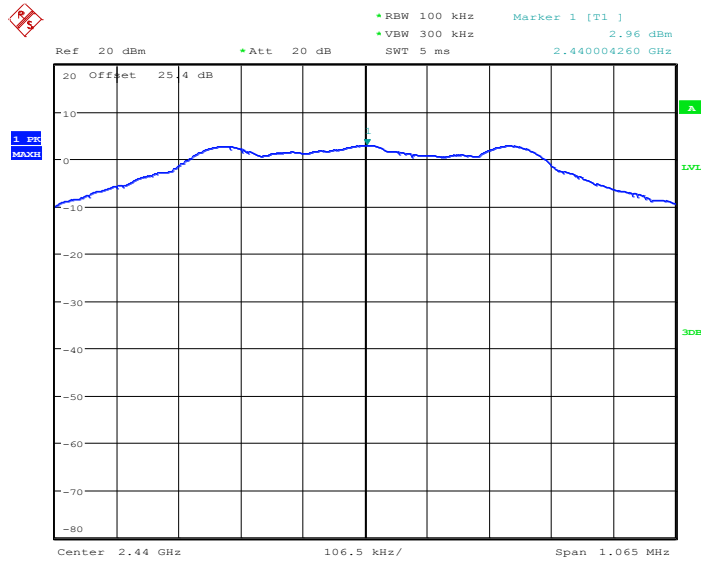

Date: 15.JUL.2013 09:14:47

PSD 100kHz Plot on Channel 39

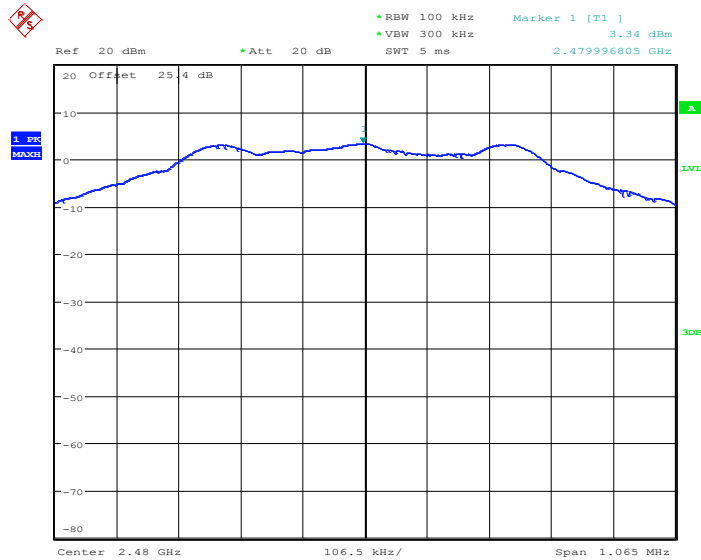

Date: 15.JUL.2013 09:18:10



3.3.7 Test Result of Power Spectral Density Plots (3kHz)

PSD 3kHz Plot on Channel 00

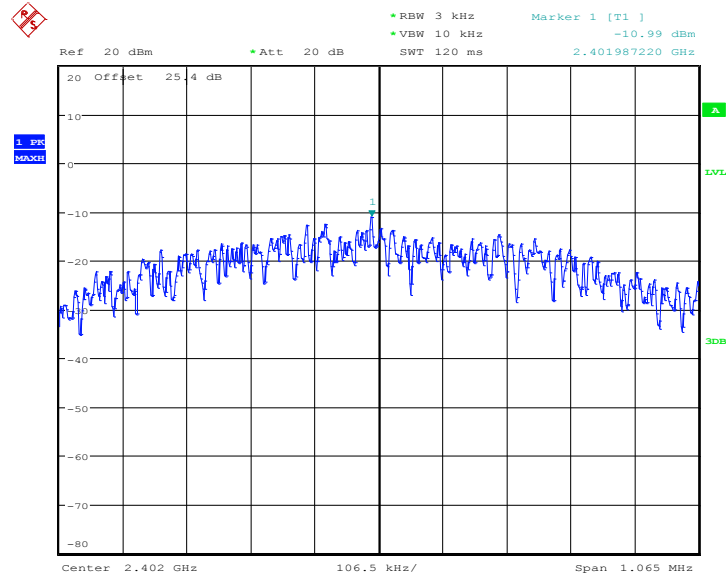

Date: 15.JUL.2013 09:08:31



PSD 3kHz Plot on Channel 19

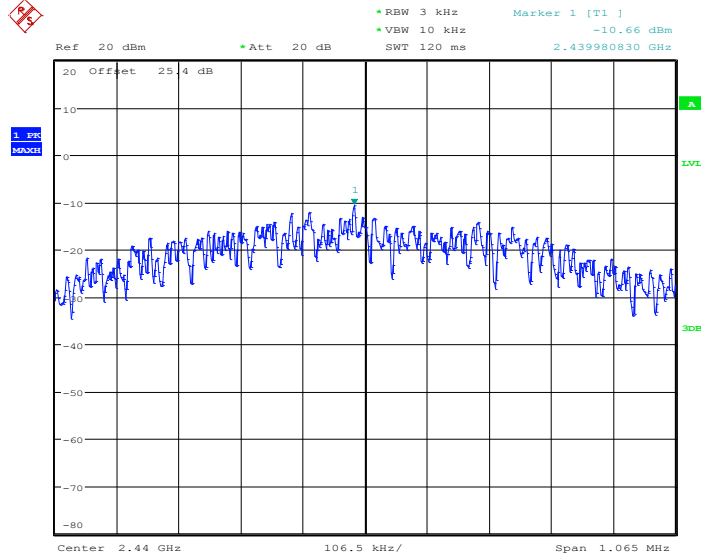

Date: 15.JUL.2013 09:14:01

PSD 3kHz Plot on Channel 39

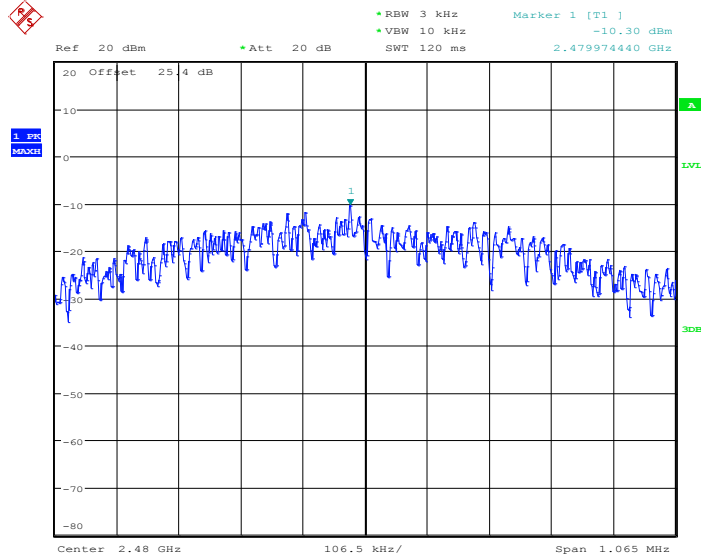

Date: 15.JUL.2013 09:17:58

3.4 Conducted Band Edges and Spurious Emission Measurement

3.4.1 Limit of Conducted Band Edges and Spurious Emission

All harmonics/spurious must be at least 20 dB down from the highest emission level within the authorized band.

3.4.2 Measuring Instruments

See list of measuring instruments of this test report.

3.4.3 Test Procedure

1. The testing follows FCC KDB Publication No. 558074 D01 DTS Meas. Guidance v03r01.
2. The RF output of EUT was connected to the spectrum analyzer by RF cable and attenuator. The path loss was compensated to the results for each measurement.
3. Set to the maximum power setting and enable the EUT transmit continuously.
4. Set RBW = 100 kHz, VBW=300 kHz, Peak Detector. Unwanted Emissions measured in any 100 kHz bandwidth outside of the authorized frequency band shall be attenuated by at least 20 dB relative to the maximum in-band peak PSD level in 100 kHz when maximum peak conducted output power procedure is used. If the transmitter complies with the conducted power limits based on the use of RMS averaging over a time interval, the attenuation required under this paragraph shall be 30 dB instead of 20 dB per 15.247(d).
5. Measure and record the results in the test report.
6. The RF fundamental frequency should be excluded against the limit line in the operating frequency band.

3.4.4 Test Setup

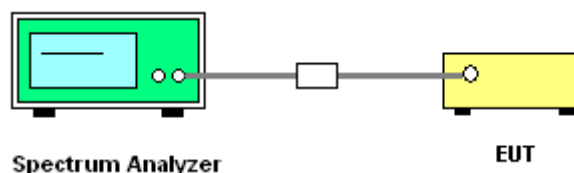



3.4.5 Test Result of Conducted Band Edges

Test Mode :	Bluetooth 4.0 - LE	Temperature :	22~25°C
Test Channel :	00 and 39	Relative Humidity :	51~55%
		Test Engineer :	Coyote Lin

Low Band Edge Plot on Channel 00

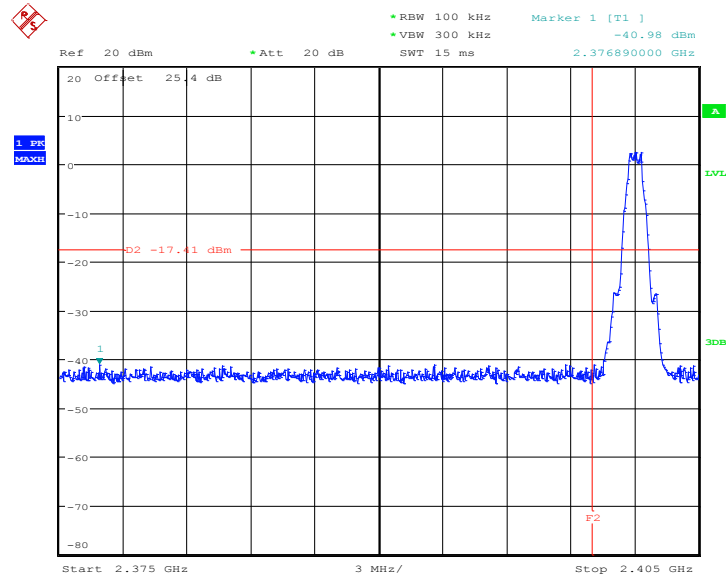

Date: 15.JUL.2013 09:10:13



High Band Edge Plot on Channel 39

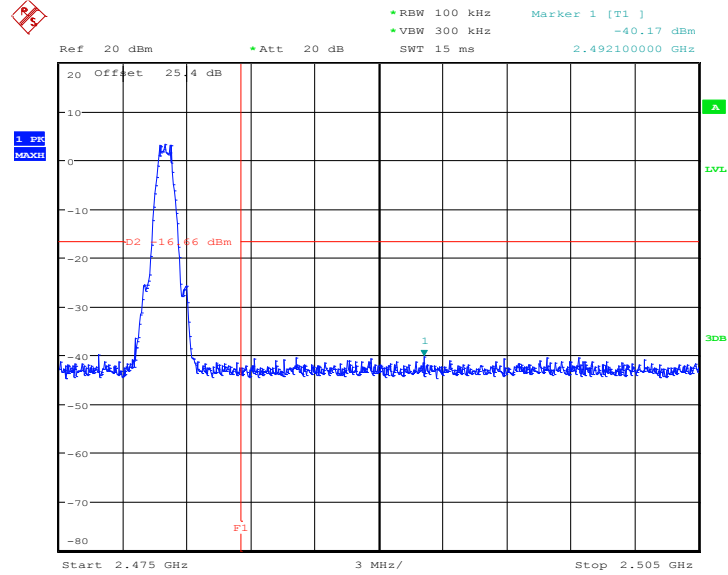

Date: 15.JUL.2013 09:18:48



3.4.6 Test Result of Conducted Spurious Emission

Test Mode :	Bluetooth 4.0 - LE	Temperature :	22~25°C
Test Channel :	00	Relative Humidity :	51~55%
		Test Engineer :	Coyote Lin

Conducted Spurious Emission Plot on Bluetooth LE 1Mbps
GFSK Channel 00

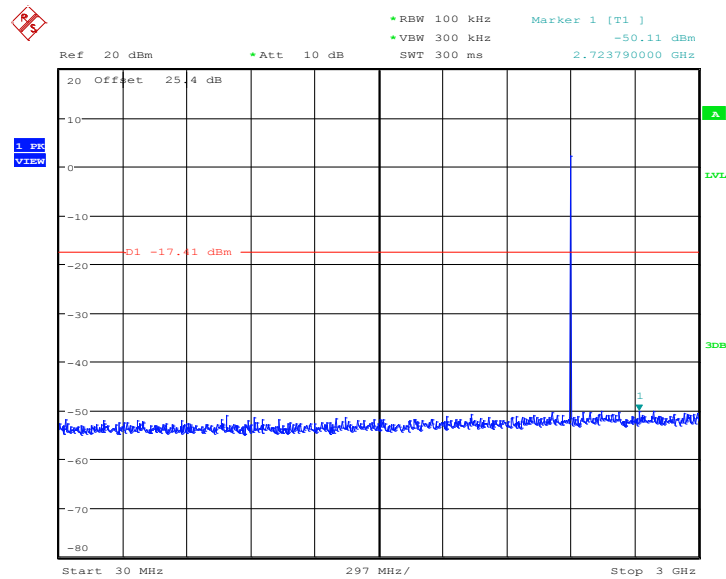

Date: 15.JUL.2013 09:10:34



Conducted Spurious Emission Plot on Bluetooth LE 1Mbps
GFSK Channel 00

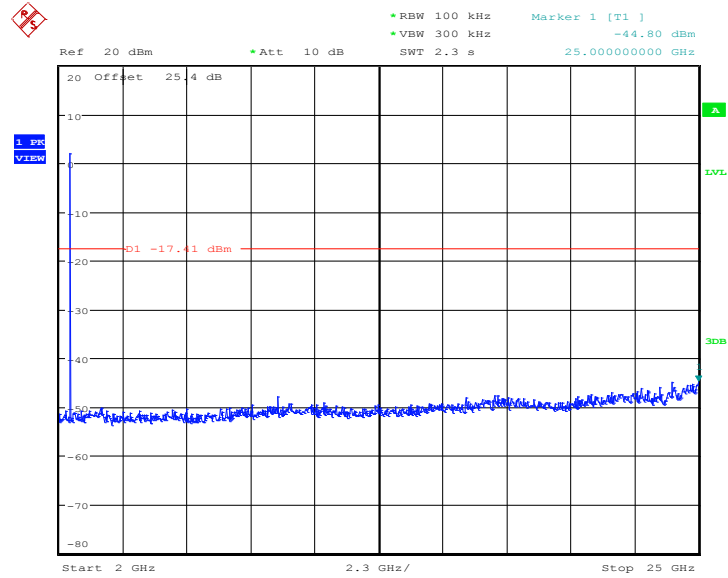

Date: 15.JUL.2013 09:10:52



Test Mode :	Bluetooth 4.0 - LE	Temperature :	22~25°C
Test Channel :	19	Relative Humidity :	51~55%
		Test Engineer :	Coyote Lin

Conducted Spurious Emission Plot on Bluetooth LE 1Mbps
GFSK Channel 19

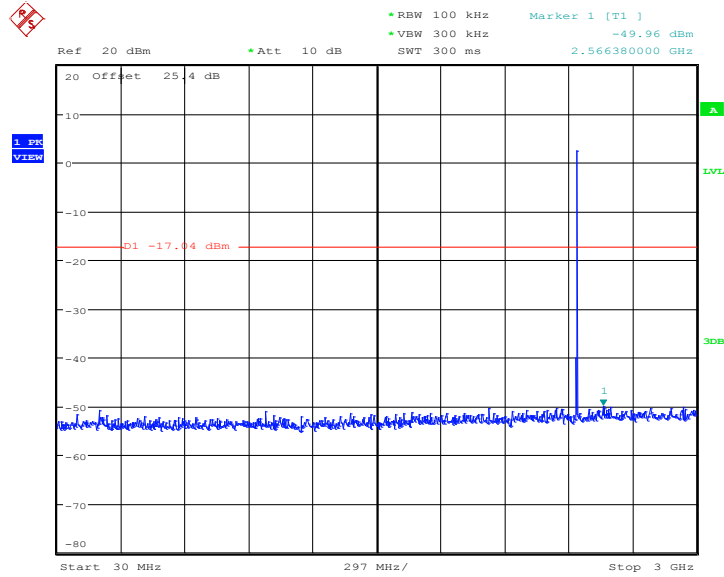

Date: 15.JUL.2013 09:15:23



Conducted Spurious Emission Plot on Bluetooth LE 1Mbps
GFSK Channel 19

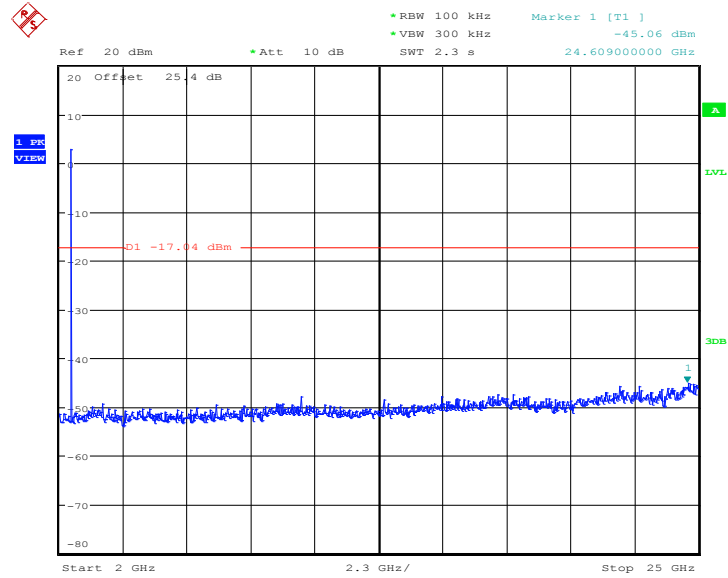

Date: 15.JUL.2013 09:15:41



Test Mode :	Bluetooth 4.0 - LE	Temperature :	22~25°C
Test Channel :	39	Relative Humidity :	51~55%
		Test Engineer :	Coyote Lin

Conducted Spurious Emission Plot on Bluetooth LE 1Mbps
GFSK Channel 39

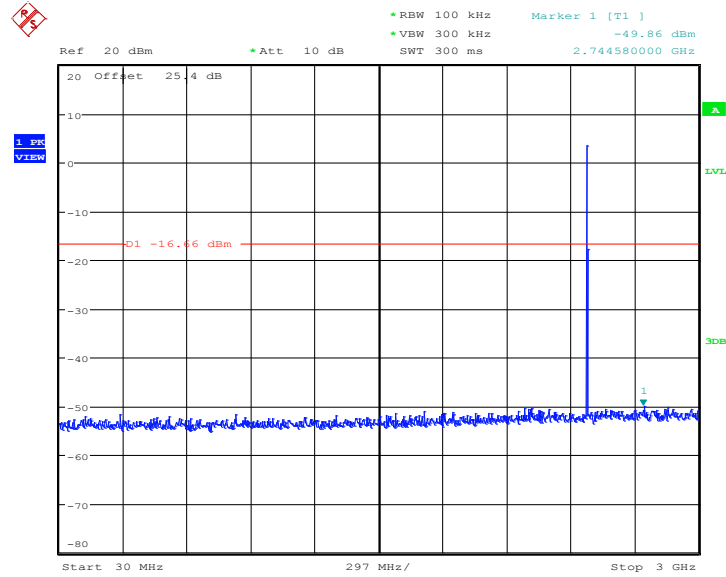

Date: 15.JUL.2013 09:19:08



Conducted Spurious Emission Plot on Bluetooth LE 1Mbps
GFSK Channel 39

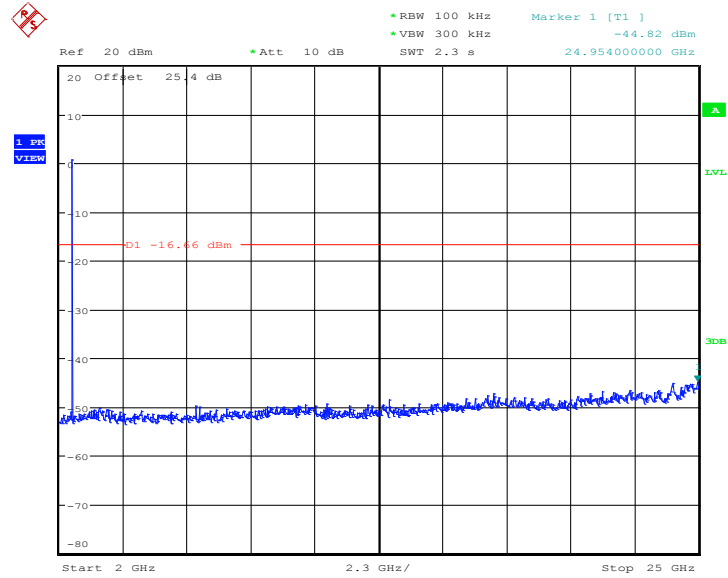

Date: 15.JUL.2013 09:19:26



3.5 Radiated Band Edges and Spurious Emission Measurement

3.5.1 Limit of Radiated Band Edges and Spurious Emission

In any 100 kHz bandwidth outside the intentional radiator frequency band, all harmonics/spurious must be at least 20 dB below the highest emission level within the authorized band. If the output power of this device was measured by spectrum analyzer, the attenuation under this paragraph shall be 30 dB instead of 20 dB. In addition, radiated emissions which fall in the restricted bands must also comply with the FCC section 15.209 limits as below.

Frequency (MHz)	Field Strength (microvolts/meter)	Measurement Distance (meters)
0.009 – 0.490	2400/F(kHz)	300
0.490 – 1.705	24000/F(kHz)	30
1.705 – 30.0	30	30
30 – 88	100	3
88 – 216	150	3
216 - 960	200	3
Above 960	500	3

3.5.2 Measuring Instruments

See list of measuring instruments of this test report.



3.5.3 Test Procedures

1. The testing follows FCC KDB Publication No. 558074 D01 DTS Meas. Guidance v03r01.
2. The EUT was arranged to its worst case and then tune the antenna tower (from 1 m to 4 m) and turntable (from 0 degree to 360 degrees) to find the maximum reading. A pre-amp and a high pass filter are used for the test in order to get better signal level.
3. The EUT was placed on a turntable with 0.8 meter above ground.
4. The EUT was set 3 meters from the interference receiving antenna, which was mounted on the top of a variable height antenna tower.
5. Corrected Reading: Antenna Factor + Cable Loss + Read Level - Preamp Factor = Level
6. For measurement below 1GHz, If the emission level of the EUT measured by the peak detector is 3 dB lower than the applicable limit, the peak emission level will be reported. Otherwise, the emission measurement will be repeated using the quasi-peak detector and reported.
7. Use the following spectrum analyzer settings:
 - (1) Span shall wide enough to fully capture the emission being measured;
 - (2) Set RBW=100 kHz for $f < 1$ GHz; $VBW \geq RBW$; Sweep = auto; Detector function = peak; Trace = max hold;
 - (3) Set RBW = 1 MHz, VBW= 3MHz for $f \geq 1$ GHz for peak measurement.
For average measurement:
 - $VBW = 10$ Hz, when duty cycle is no less than 98 percent.
 - $VBW \geq 1/T$, when duty cycle is less than 98 percent where T is the minimum transmission duration over which the transmitter is on and is transmitting at its maximum power control level for the tested mode of operation.

Band	Duty Cycle(%)	T(μ s)	1/T(kHz)	VBW Setting
Bluetooth 4.0 - LE	62.21	390.385	2.562	3kHz

Marker-Delta method :

- (1) Set RBW = 1 MHz, VBW = 3 MHz, peak detector.

Repeat the measurement with an average detector, use RBW = 1MHz

VBW = 10 Hz, when duty cycle is no less than 98 percent.

VBW $\geq 1/T$, when duty cycle is less than 98 percent

- (2) Set span = 10MHz, that encompasses both the peak of the fundamental emission and the band-edge emission under investigation. Set RBW = 100kHz, 1% of the total span. Set VBW = 100kHz \geq RBW.

- (3) Subtract the delta measured in step (2) from the field strengths measured in step (1).

The resultant field strengths (peak/average) are then used to determine band-edge compliance as required by Section 15.205.

3.5.4 Test Setup

For radiated emissions below 30MHz

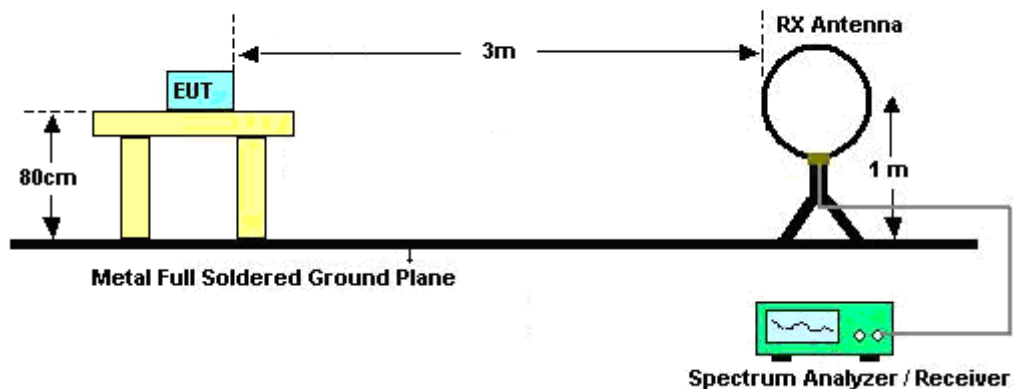

For radiated emissions from 30MHz to 1GHz

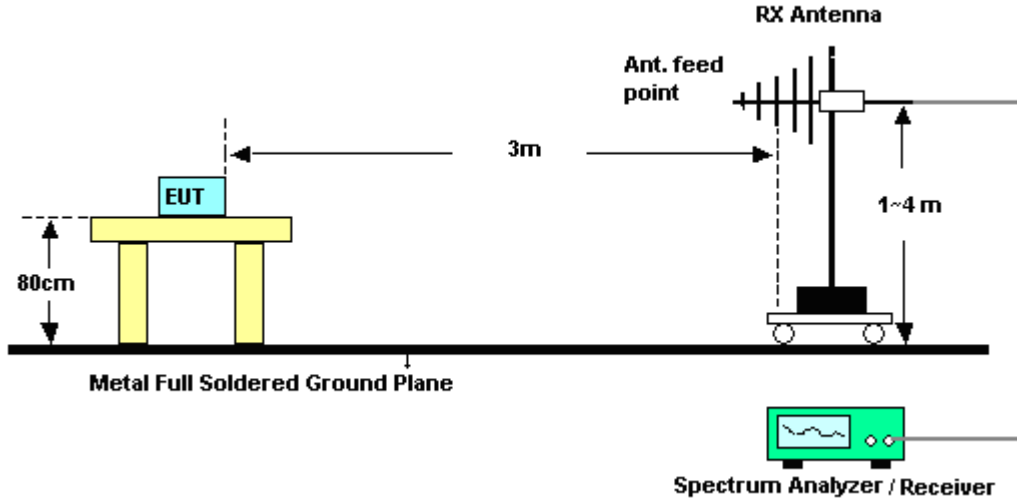

For radiated emissions above 1GHz

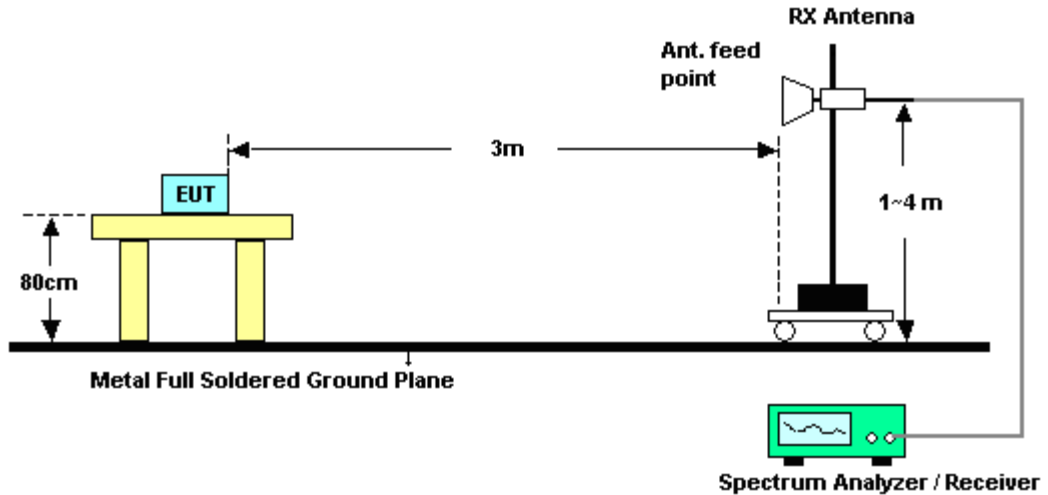

3.5.5 Test Results of Radiated Spurious Emissions (9 kHz ~ 30 MHz)

The low frequency, which started from 9 kHz to 30MHz, was pre-scanned and the result which was 20dB lower than the limit line per 15.31(o) was not reported.



3.5.6 Test Result of Radiated Spurious at Band Edges

Test Mode :	Mode 1	Temperature :	20~22°C
Test Channel :	00	Relative Humidity :	46~47%
		Test Engineer :	Jet Lu

ANTENNA POLARITY : HORIZONTAL										
Frequency (MHz)	Level (dB μ V /m)	Over Limit (dB)	Limit Line (dB μ V /m)	Read Level (dB μ V)	Antenna Factor (dB)	Cable Loss (dB)	Preamp Factor (dB)	Ant Pos (cm)	Table Pos (deg)	Remark
2375.61	49.07	-24.93	74	46.58	32.2	6.21	35.92	137	29	Peak
2389.65	37.32	-16.68	54	34.75	32.27	6.22	35.92	137	29	Average

ANTENNA POLARITY : VERTICAL										
Frequency (MHz)	Level (dB μ V /m)	Over Limit (dB)	Limit Line (dB μ V /m)	Read Level (dB μ V)	Antenna Factor (dB)	Cable Loss (dB)	Preamp Factor (dB)	Ant Pos (cm)	Table Pos (deg)	Remark
2369.67	48.77	-25.23	74	46.53	31.95	6.21	35.92	138	309	Peak
2387.67	37.24	-16.76	54	34.88	32.06	6.22	35.92	138	309	Average



Test Mode :	Mode 3	Temperature :	20~22°C
Test Channel :	39	Relative Humidity :	46~47%
		Test Engineer :	Jet Lu

ANTENNA POLARITY : HORIZONTAL										
Frequency (MHz)	Level (dBμV/m)	Over Limit (dB)	Limit Line (dBμV/m)	Read Level (dBμV)	Antenna Factor (dB)	Cable Loss (dB)	Preamp Factor (dB)	Ant Pos (cm)	Table Pos (deg)	Remark
2483.5	61.16	-12.84	74	57.91	32.63	6.45	35.83	103	22	Peak
2483.5	57.25	*3.25	54	54	32.63	6.45	35.83	103	22	Average
2483.5	43.45	-30.55	74	-	-	-	-	-	-	Peak
2483.5	42.57	-11.43	54	-	-	-	-	-	-	Average

Summary results of marker-delta method:

ANTENNA POLARITY : HORIZONTAL						
Test mode	Maximum field strength of the fundamental emission (dBμV/m)	Delta Result (dB)	Measurement Result (dBμV/m)	Limit (dBμV/m)	Margin (dB)	Result
Peak	102.89	59.44	43.45	74	-30.55	Pass
Average	102.01	59.44	42.57	54	-11.43	Pass

Note :

1. Measurement result = Maximum field strength – Delta result
2. *Delta-Marker Method is used for the 2483.5MHz average measurement as described in the test procedure of this report and the test result is under 11.43dB.

ANTENNA POLARITY : VERTICAL										
Frequency (MHz)	Level (dBμV/m)	Over Limit (dB)	Limit Line (dBμV/m)	Read Level (dBμV)	Antenna Factor (dB)	Cable Loss (dB)	Preamp Factor (dB)	Ant Pos (cm)	Table Pos (deg)	Remark
2483.5	58.54	-15.46	74	55.33	32.59	6.45	35.83	199	325	Peak
2483.5	53.74	*-0.26	54	50.53	32.59	6.45	35.83	199	325	Average
2483.5	43.32	-30.68	74	-	-	-	-	-	-	Peak
2483.5	42.45	-11.55	54	-	-	-	-	-	-	Average

Summary results of marker-delta method:

ANTENNA POLARITY : VERTICAL						
Test mode	Maximum field strength of the fundamental emission (dBμV/m)	Delta Result (dB)	Measurement Result (dBμV/m)	Limit (dBμV/m)	Margin (dB)	Result
Peak	99.36	56.04	43.32	74	-30.68	Pass
Average	98.49	56.04	42.45	54	-11.55	Pass

Note :

1. Measurement result = Maximum field strength – Delta result
2. *Delta-Marker Method is used for the 2483.5MHz average measurement as described in the test procedure of this report and the test result is under 11.55dB.



Test Mode :	Bluetooth 4.0 - LE	Temperature :	20~22°C
Test Channel :	39	Relative Humidity :	46~47%
Test Engineer :	Jet Lu	Polarization :	Horizontal

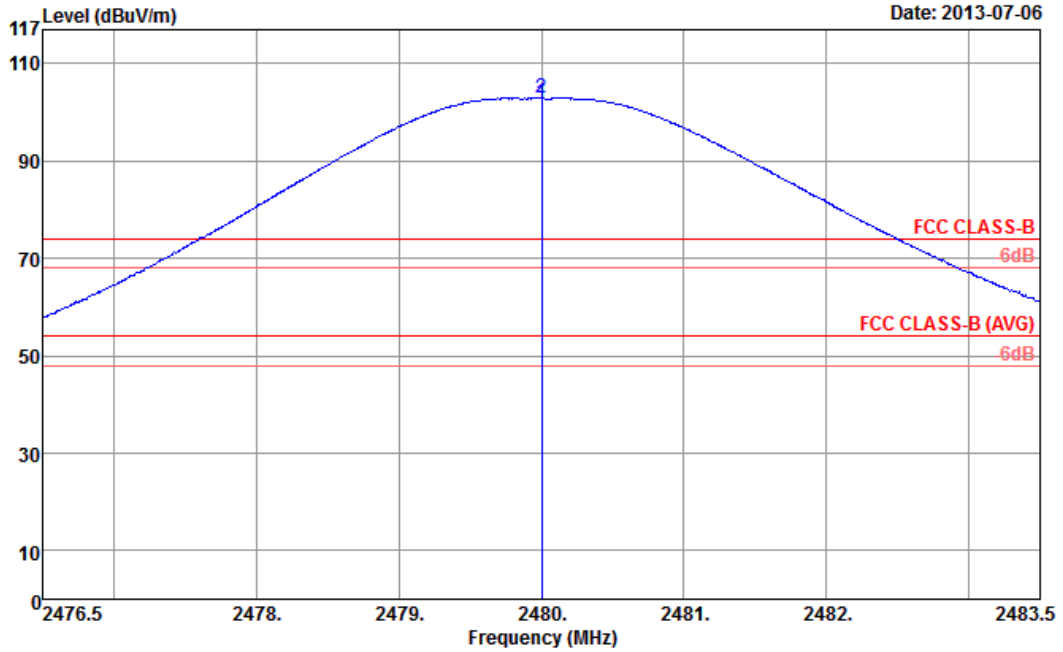

Site : 03CH08-HY
 Condition : FCC CLASS-B 3m HORN_130108 HORIZONTAL
 : RBW:1000.000KHz VBW:3000.000KHz SWT:Auto

	Freq	Level	Over Limit	Limit Line	ReadAntenna Level	Antenna Factor	Cable Loss	Preamp Factor	A/Pos	T/Pos	Remark
	MHz	dBuV/m	dB	dBuV/m	dBuV	dB/m	dB	dB	cm	deg	
1 *	2480.00	102.01	48.01	54.00	98.76	32.63	6.45	35.83	103	22	Average
2 *	2480.00	102.89	28.89	74.00	99.64	32.63	6.45	35.83	103	22	Peak

* Maximum field strength of the fundamental emission



Test Mode :	Bluetooth 4.0 - LE	Temperature :	20~22°C
Test Channel :	39	Relative Humidity :	46~47%
Test Engineer :	Jet Lu	Polarization :	Horizontal

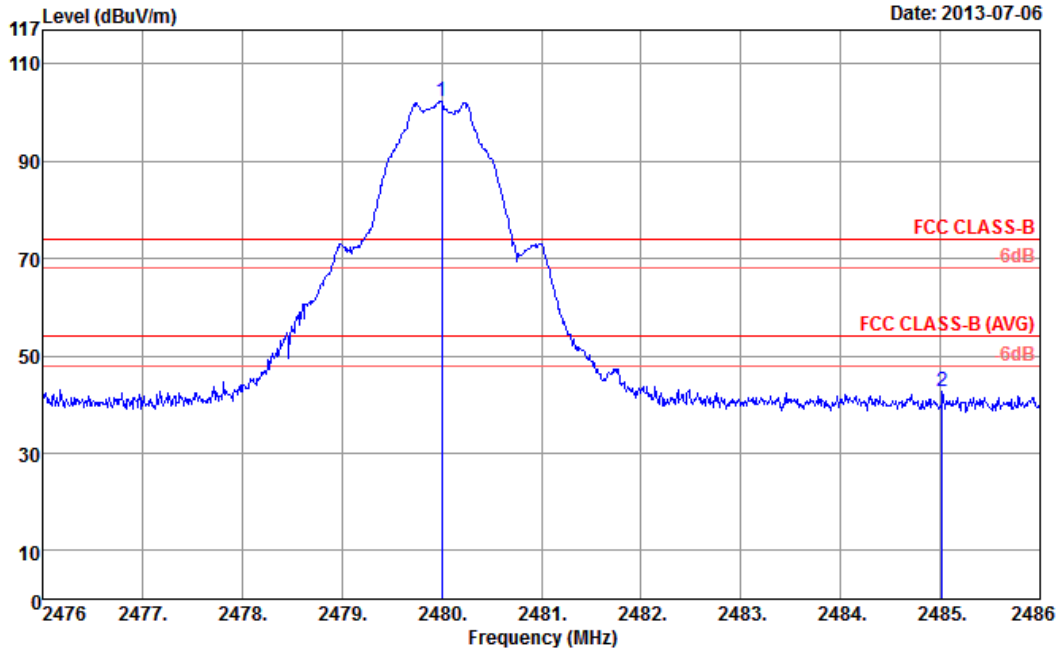

Site : 03CH08-HY
 Condition : FCC CLASS-B 3m HORN_130108 HORIZONTAL
 : RBW:100.000KHz VBW:300.000KHz SWT:Auto

	Freq	Level	Over Limit	Limit Line	ReadAntenna Level	Antenna Factor	Cable Loss	Preamp Factor	A/Pos	T/Pos	Remark
	MHz	dBUV/m	dB	dBUV/m	dBuV	dB/m	dB	dB	cm	deg	
1 *	2480.00	102.24	28.24	74.00	98.99	32.63	6.45	35.83	103	22	Peak
2	2485.02	42.80	-31.20	74.00	39.55	32.63	6.45	35.83	103	22	Peak

* Marker-Delta Method (RBW/VBW=100kHz): 59.44 dB , single carrier Mode



Test Mode :	Bluetooth 4.0 - LE	Temperature :	20~22°C
Test Channel :	39	Relative Humidity :	46~47%
Test Engineer :	Jet Lu	Polarization :	Vertical

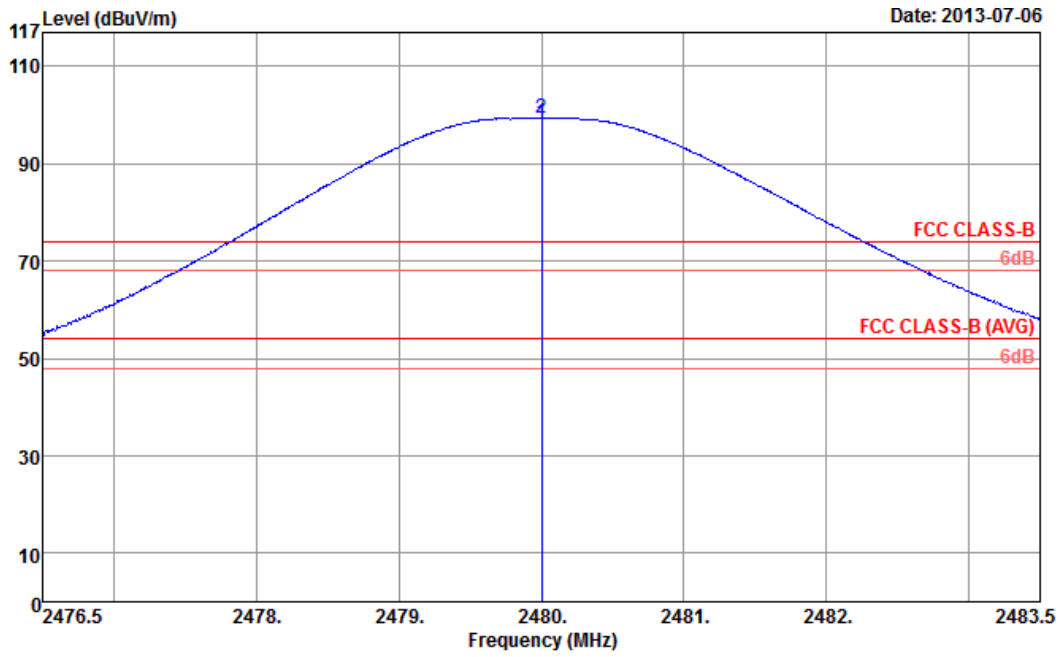

Site : 03CH08-HY
 Condition : FCC CLASS-B 3m HORN_130108 VERTICAL
 : RBW:1000.000KHz VBW:3000.000KHz SWT:Auto

	Freq	Level	Over Limit	Limit Line	ReadAntenna Level	Antenna Factor	Cable Loss	Preamp Factor	A/Pos	T/Pos	Remark
	MHz	dBuV/m	dB	dBuV/m	dBuV	dB/m	dB	dB	cm	deg	
1 *	2480.00	98.49	44.49	54.00	95.28	32.59	6.45	35.83	199	325	Average
2 *	2480.00	99.36	25.36	74.00	96.15	32.59	6.45	35.83	199	325	Peak

* Maximum field strength of the fundamental emission



Test Mode :	Bluetooth 4.0 - LE	Temperature :	20~22°C
Test Channel :	39	Relative Humidity :	46~47%
Test Engineer :	Jet Lu	Polarization :	Vertical

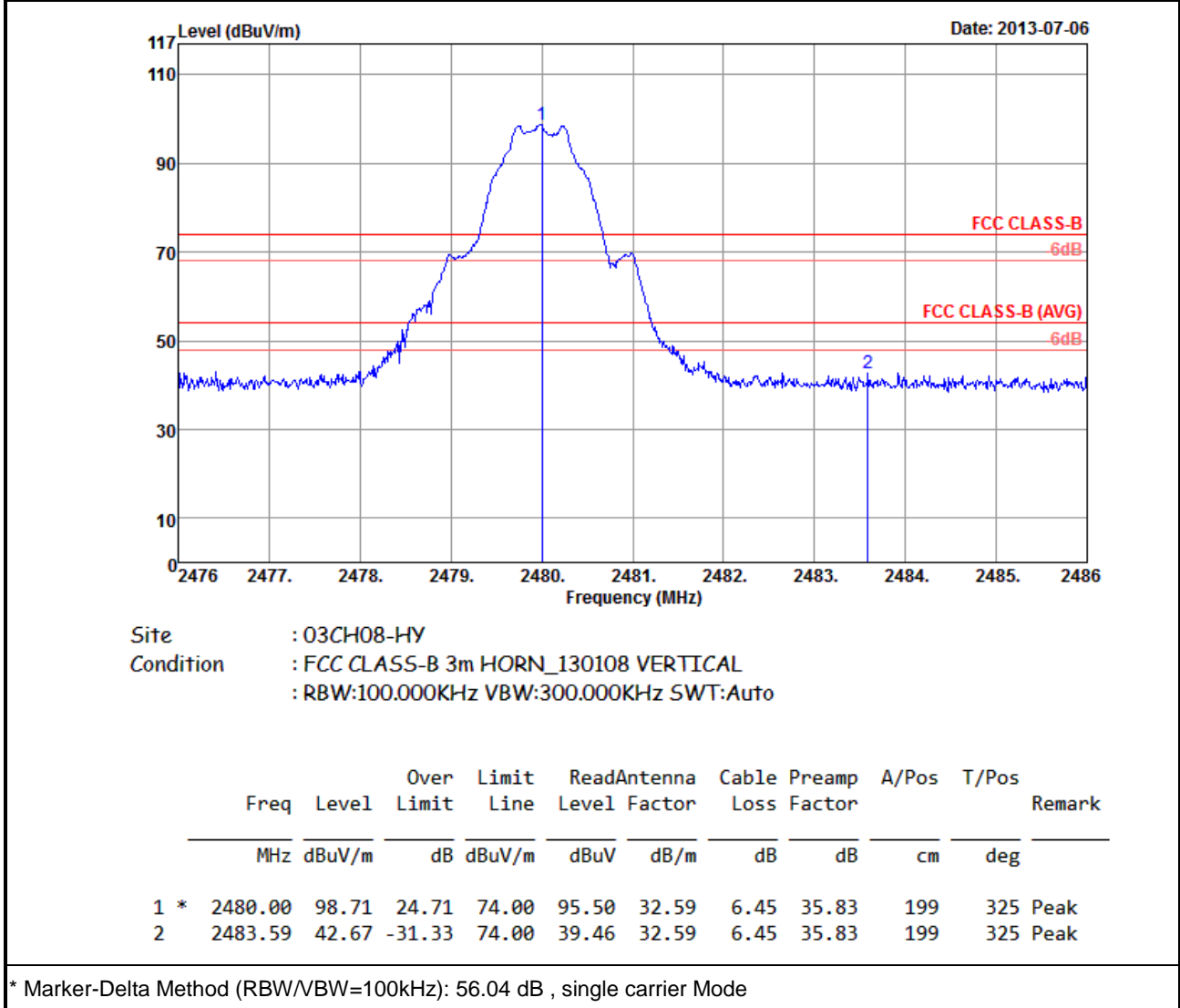

3.5.7 Test Result of Radiated Spurious Emission (30MHz ~ 10th Harmonic)

Note: Pre-scanned all test modes and only choose the worst case mode recorded in the test report for radiated spurious emission below 1GHz.

Test Mode :	Mode 1	Temperature :	20~22°C
Test Channel :	00	Relative Humidity :	46~47%
Test Engineer :	Jet Lu	Polarization :	Horizontal
Remark :	<ol style="list-style-type: none"> 2402 MHz is fundamental signal which can be ignored. 7206 MHz is not within a restricted band, and its limit line is 20dB below the highest emission level. For example, 98.44 dBµV/m - 20dB = 78.44 dBµV/m. Average measurement was not performed if peak level went lower than the average limit. 		

Frequency (MHz)	Level (dBµV/m)	Over Limit (dB)	Limit Line (dBµV/m)	Read Level (dBµV)	Antenna Factor (dB)	Cable Loss (dB)	Preamp Factor (dB)	Ant Pos (cm)	Table Pos (deg)	Remark
2402	97.82	-	-	95.23	32.27	6.22	35.9	137	29	Average
2402	98.44	-	-	95.85	32.27	6.22	35.9	137	29	Peak
4803	44.6	-29.4	74	57.7	34.46	8	55.56	100	0	Peak
7206	47.13	-31.31	78.44	57.51	35.62	10.49	56.49	100	0	Peak

Note: Other harmonics are lower than background noise.



Test Mode :	Mode 1	Temperature :	20~22°C
Test Channel :	00	Relative Humidity :	46~47%
Test Engineer :	Jet Lu	Polarization :	Vertical
Remark :	1. 2402 MHz is fundamental signal which can be ignored. 2. 7206 MHz is not within a restricted band, and its limit line is 20dB below the highest emission level. 3. Average measurement was not performed if peak level went lower than the average limit.		

Frequency (MHz)	Level (dBμV/m)	Over Limit (dB)	Limit Line (dBμV/m)	Read Level (dBμV)	Antenna Factor (dB)	Cable Loss (dB)	Preamp Factor (dB)	Ant Pos (cm)	Table Pos (deg)	Remark
2402	95.26	-	-	92.88	32.06	6.22	35.9	138	309	Average
2402	95.44	-	-	93.06	32.06	6.22	35.9	138	309	Peak
4803	44.03	-29.97	74	57.13	34.46	8	55.56	100	0	Peak
7206	46.23	-29.21	75.44	56.63	35.6	10.49	56.49	100	0	Peak

Note: Other harmonics are lower than background noise.



Test Mode :	Mode 2	Temperature :	20~22°C
Test Channel :	19	Relative Humidity :	46~47%
Test Engineer :	Jet Lu	Polarization :	Horizontal
Remark :	1. 2440 MHz is fundamental signal which can be ignored. 2. Average measurement was not performed if peak level went lower than the average limit.		

Frequency (MHz)	Level (dBμV/m)	Over Limit (dB)	Limit Line (dBμV/m)	Read Level (dBμV)	Antenna Factor (dB)	Cable Loss (dB)	Preamp Factor (dB)	Ant Pos (cm)	Table Pos (deg)	Remark
2440	100.26	-	-	97.31	32.49	6.34	35.88	197	20	Average
2440	101.22	-	-	98.27	32.49	6.34	35.88	197	20	Peak
4881	45.16	-28.84	74	58.29	34.4	8.15	55.68	100	0	Peak
7320	47.33	-26.67	74	57.47	35.63	10.47	56.24	100	0	Peak

Note: Other harmonics are lower than background noise.

Test Mode :	Mode 2	Temperature :	20~22°C
Test Channel :	19	Relative Humidity :	46~47%
Test Engineer :	Jet Lu	Polarization :	Vertical
Remark :	1. 2440 MHz is fundamental signal which can be ignored. 2. Average measurement was not performed if peak level went lower than the average limit.		

Frequency (MHz)	Level (dBμV/m)	Over Limit (dB)	Limit Line (dBμV/m)	Read Level (dBμV)	Antenna Factor (dB)	Cable Loss (dB)	Preamp Factor (dB)	Ant Pos (cm)	Table Pos (deg)	Remark
2440	97.34	-	-	94.5	32.38	6.34	35.88	106	300	Average
2440	98.18	-	-	95.34	32.38	6.34	35.88	106	300	Peak
4881	44.81	-29.19	74	57.94	34.4	8.15	55.68	100	0	Peak
7320	48.04	-25.96	74	58.27	35.54	10.47	56.24	100	0	Peak

Note: Other harmonics are lower than background noise.



Test Mode :	Mode 3	Temperature :	20~22°C
Test Channel :	39	Relative Humidity :	46~47%
Test Engineer :	Jet Lu	Polarization :	Horizontal
Remark :	1. 2481 MHz is fundamental signal which can be ignored. 2. Average measurement was not performed if peak level went lower than the average limit.		

Frequency (MHz)	Level (dBμV/m)	Over Limit (dB)	Limit Line (dBμV/m)	Read Level (dBμV)	Antenna Factor (dB)	Cable Loss (dB)	Preamp Factor (dB)	Ant Pos (cm)	Table Pos (deg)	Remark
103.17	24.43	-19.07	43.5	44.54	10.61	1.19	31.91	-	-	Peak
133.68	25.92	-17.58	43.5	45.1	11.31	1.35	31.84	100	26	Peak
199.56	21.85	-21.65	43.5	43.09	8.82	1.64	31.7	-	-	Peak
417.6	23.09	-22.91	46	35.67	16.45	2.37	31.4	-	-	Peak
622	23.06	-22.94	46	32.64	18.63	2.88	31.09	-	-	Peak
833.4	25.44	-20.56	46	32.72	20.23	3.33	30.84	-	-	Peak
2481	102.03	-	-	98.78	32.63	6.45	35.83	103	22	Average
2481	102.92	-	-	99.67	32.63	6.45	35.83	103	22	Peak
4959	44.21	-29.79	74	57.46	34.33	8.26	55.84	100	0	Peak
7440	47.2	-26.8	74	57.05	35.68	10.47	56	100	0	Peak

Note: Other harmonics are lower than background noise.



Test Mode :	Mode 3	Temperature :	20~22°C
Test Channel :	39	Relative Humidity :	46~47%
Test Engineer :	Jet Lu	Polarization :	Vertical
Remark :	1. 2481 MHz is fundamental signal which can be ignored. 2. Average measurement was not performed if peak level went lower than the average limit.		

Frequency (MHz)	Level (dBμV/m)	Over Limit (dB)	Limit Line (dBμV/m)	Read Level (dBμV)	Antenna Factor (dB)	Cable Loss (dB)	Preamp Factor (dB)	Ant Pos (cm)	Table Pos (deg)	Remark
42.15	33.08	-6.92	40	53.21	11.1	0.76	31.99	100	97	Peak
66.72	31.48	-8.52	40	57.18	5.27	0.97	31.94	-	-	Peak
97.77	27.72	-15.78	43.5	48.85	9.65	1.15	31.93	-	-	Peak
494.6	24.71	-21.29	46	36.3	17.01	2.57	31.17	-	-	Peak
673.1	25.91	-20.09	46	35.04	18.87	2.99	30.99	-	-	Peak
843.9	25.45	-20.55	46	32.76	20.13	3.36	30.8	-	-	Peak
2481	98.5	-	-	95.29	32.59	6.45	35.83	199	325	Average
2481	99.34	-	-	96.13	32.59	6.45	35.83	199	325	Peak
4959	44.15	-29.85	74	57.4	34.33	8.26	55.84	100	0	Peak
7440	46.52	-27.48	74	56.61	35.44	10.47	56	100	0	Peak

Note: Other harmonics are lower than background noise.

3.6 AC Conducted Emission Measurement

3.6.1 Limit of AC Conducted Emission

For equipment that is designed to be connected to the public utility (AC) power line, the radio frequency voltage that is conducted back onto the AC power line on any frequency or frequencies within the band 150 kHz to 30 MHz shall not exceed the limits in the following table.

Frequency of emission (MHz)	Conducted limit (dB μ V)	
	Quasi-peak	Average
0.15-0.5	66 to 56*	56 to 46*
0.5-5	56	46
5-30	60	50

*Decreases with the logarithm of the frequency.

3.6.2 Measuring Instruments

See list of measuring instruments of this test report.

3.6.3 Test Procedures

1. The EUT was placed 0.4 meter from the conducting wall of the shielding room was kept at least 80 centimeters from any other grounded conducting surface.
2. Connect EUT to the power mains through a line impedance stabilization network (LISN).
3. All the support units are connecting to the other LISN.
4. The LISN provides 50 ohm coupling impedance for the measuring instrument.
5. The FCC states that a 50 ohm, 50 microhenry LISN should be used.
6. Both sides of AC line were checked for maximum conducted interference.
7. The frequency range from 150 kHz to 30 MHz was searched.
8. Set the test-receiver system to Peak Detect Function and specified bandwidth with Maximum Hold Mode.

3.6.4 Test Setup

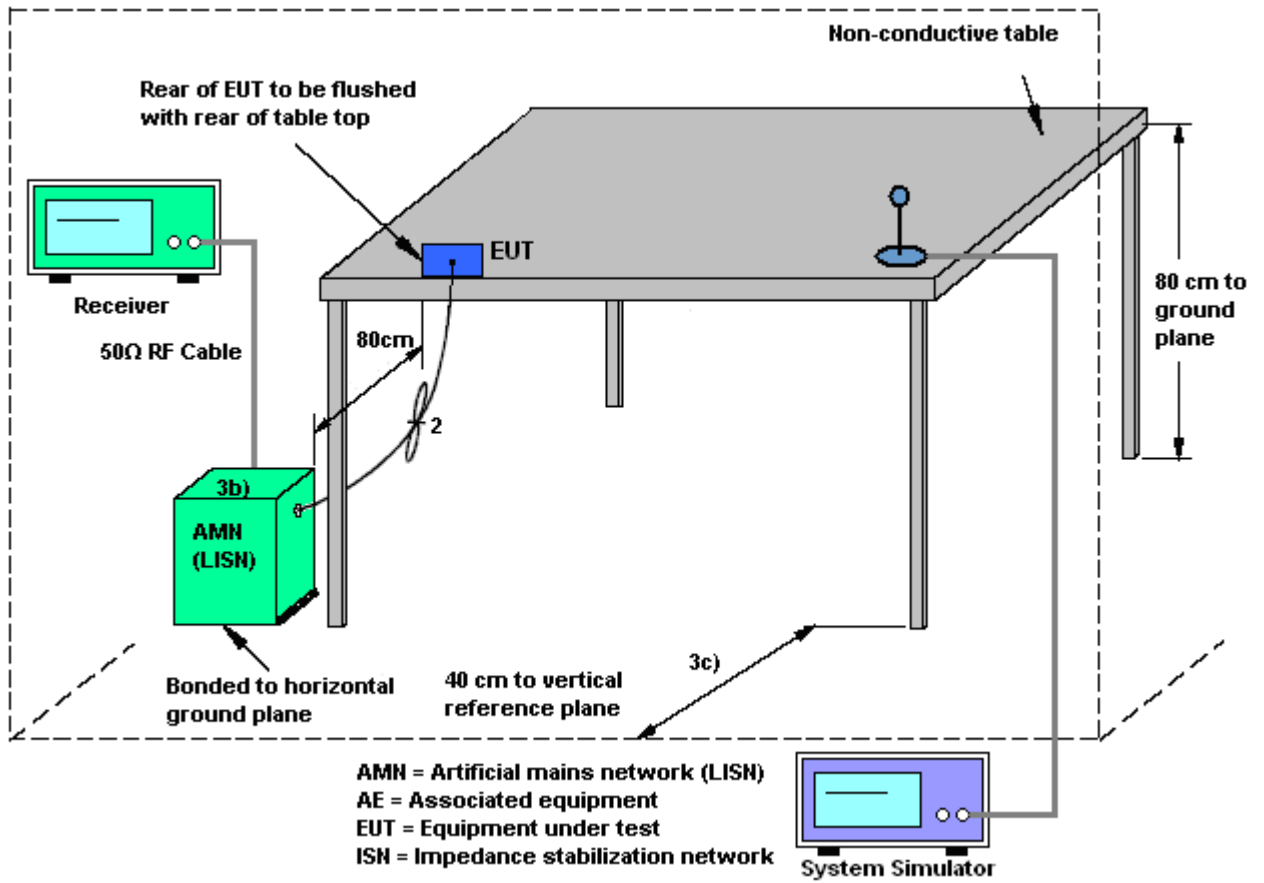

3.6.5 Test Result of AC Conducted Emission

Test Mode :	Mode 1	Temperature :	20~22°C
Test Engineer :	Slash Huang	Relative Humidity :	45~47%
Test Voltage :	120Vac / 60Hz	Phase :	Line
Function Type :	GSM850 Idle + Bluetooth Link + WLAN (2.4GHz) Link + MP3 + Earphone + USB Cable (Charging from Adapter)		

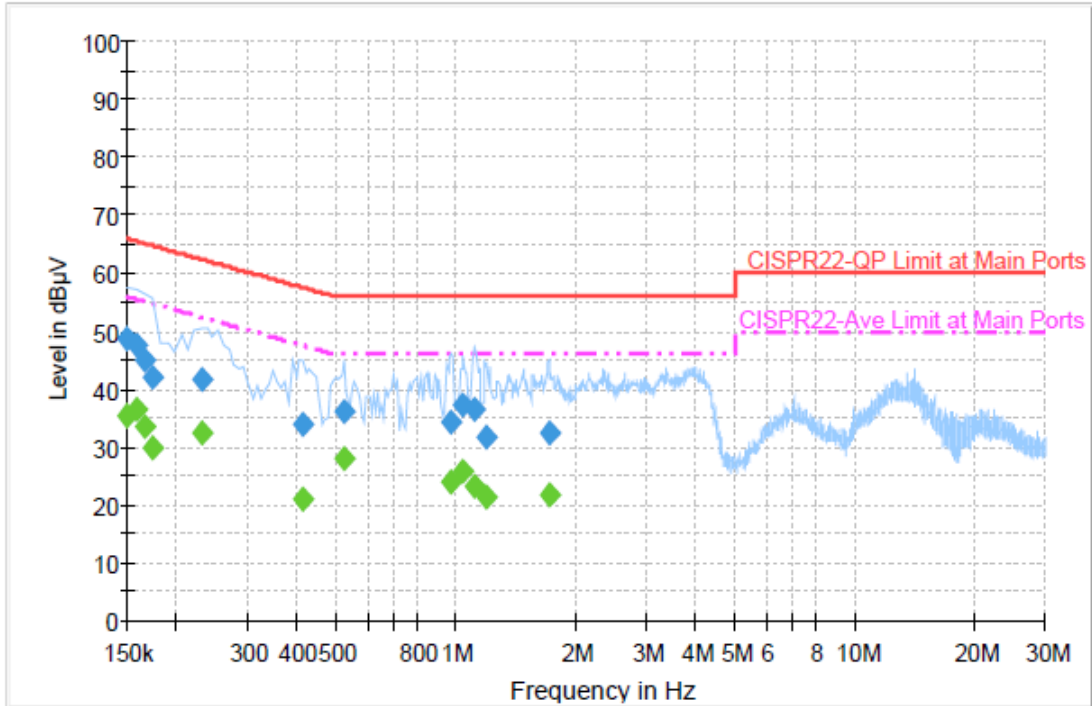

Final Result : Quasi-Peak

Frequency (MHz)	Quasi-Peak (dBµV)	Filter	Line	Corr. (dB)	Margin (dB)	Limit (dBµV)
0.150000	48.6	Off	L1	19.4	17.4	66.0
0.158000	47.5	Off	L1	19.3	18.1	65.6
0.166000	45.1	Off	L1	19.4	20.1	65.2
0.174000	41.9	Off	L1	19.4	22.9	64.8
0.230000	41.7	Off	L1	19.4	20.7	62.4
0.414000	33.9	Off	L1	19.4	23.7	57.6
0.526000	36.0	Off	L1	19.4	20.0	56.0
0.974000	34.3	Off	L1	19.4	21.7	56.0
1.046000	37.4	Off	L1	19.4	18.6	56.0
1.110000	36.6	Off	L1	19.4	19.4	56.0
1.198000	31.6	Off	L1	19.5	24.4	56.0
1.710000	32.6	Off	L1	19.5	23.4	56.0

Test Mode :	Mode 1	Temperature :	20~22°C
Test Engineer :	Slash Huang	Relative Humidity :	45~47%
Test Voltage :	120Vac / 60Hz	Phase :	Line
Function Type :	GSM850 Idle + Bluetooth Link + WLAN (2.4GHz) Link + MP3 + Earphone + USB Cable (Charging from Adapter)		

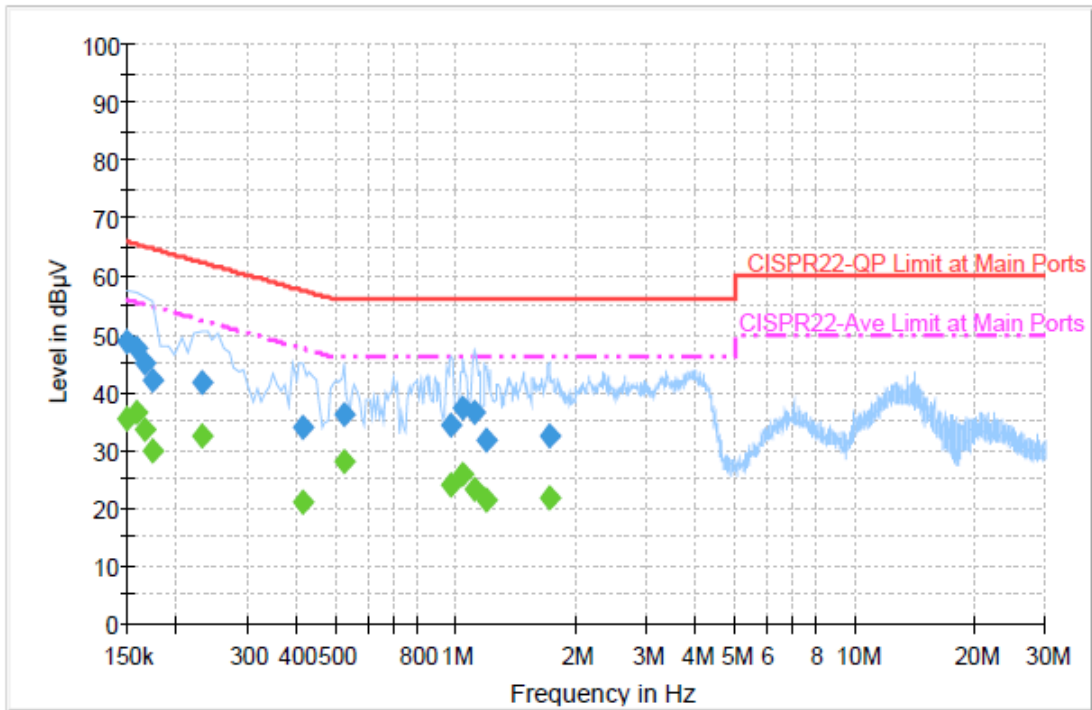

Final Result : Average

Frequency (MHz)	Average (dBµV)	Filter	Line	Corr. (dB)	Margin (dB)	Limit (dBµV)
0.150000	35.4	Off	L1	19.4	20.6	56.0
0.158000	36.5	Off	L1	19.3	19.1	55.6
0.166000	33.6	Off	L1	19.4	21.6	55.2
0.174000	29.8	Off	L1	19.4	25.0	54.8
0.230000	32.4	Off	L1	19.4	20.0	52.4
0.414000	21.0	Off	L1	19.4	26.6	47.6
0.526000	27.9	Off	L1	19.4	18.1	46.0
0.974000	23.9	Off	L1	19.4	22.1	46.0
1.046000	25.9	Off	L1	19.4	20.1	46.0
1.110000	23.2	Off	L1	19.4	22.8	46.0
1.198000	21.4	Off	L1	19.5	24.6	46.0
1.710000	21.7	Off	L1	19.5	24.3	46.0



Test Mode :	Mode 1	Temperature :	20~22°C
Test Engineer :	Slash Huang	Relative Humidity :	45~47%
Test Voltage :	120Vac / 60Hz	Phase :	Neutral
Function Type :	GSM850 Idle + Bluetooth Link + WLAN (2.4GHz) Link + MP3 + Earphone + USB Cable (Charging from Adapter)		

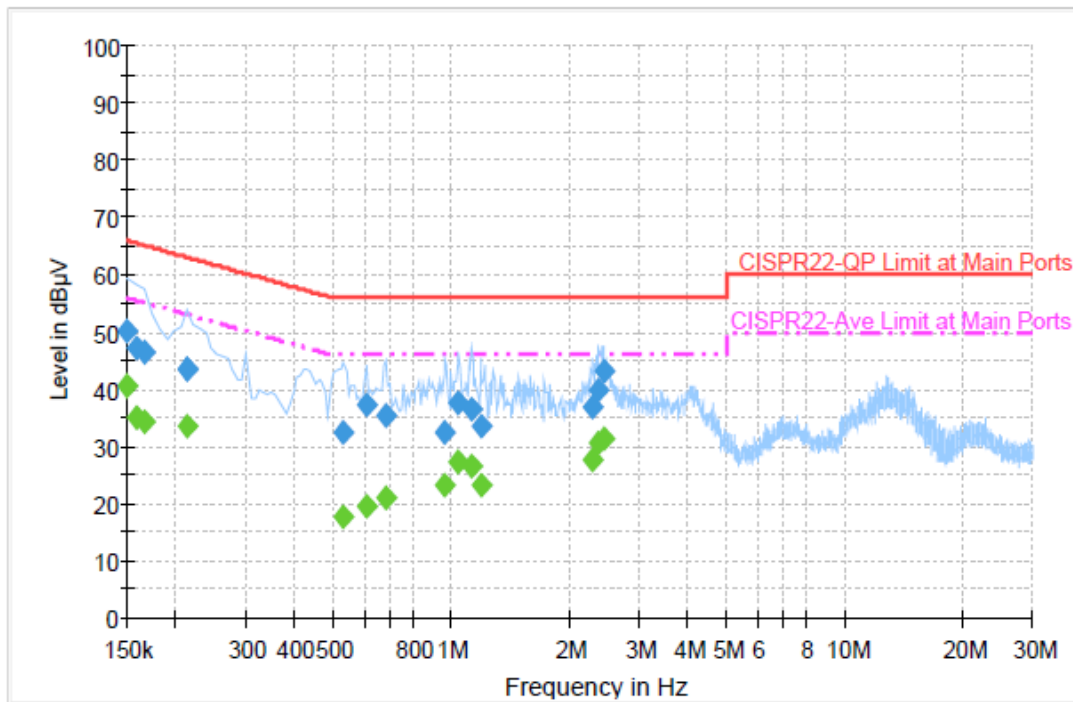

Final Result : Quasi-Peak

Frequency (MHz)	Quasi-Peak (dBµV)	Filter	Line	Corr. (dB)	Margin (dB)	Limit (dBµV)
0.150000	50.2	Off	N	19.4	15.8	66.0
0.158000	47.4	Off	N	19.4	18.2	65.6
0.166000	46.5	Off	N	19.4	18.7	65.2
0.214000	43.6	Off	N	19.4	19.4	63.0
0.214000	43.6	Off	N	19.4	19.4	63.0
0.534000	32.5	Off	N	19.4	23.5	56.0
0.606000	37.2	Off	N	19.4	18.8	56.0
0.686000	35.4	Off	N	19.5	20.6	56.0
0.966000	32.6	Off	N	19.4	23.4	56.0
1.046000	37.5	Off	N	19.5	18.5	56.0
1.126000	36.4	Off	N	19.5	19.6	56.0
1.190000	33.6	Off	N	19.5	22.4	56.0
2.286000	37.0	Off	N	19.6	19.0	56.0
2.374000	39.8	Off	N	19.7	16.2	56.0
2.438000	43.3	Off	N	19.7	12.7	56.0



Test Mode :	Mode 1	Temperature :	20~22°C
Test Engineer :	Slash Huang	Relative Humidity :	45~47%
Test Voltage :	120Vac / 60Hz	Phase :	Neutral
Function Type :	GSM850 Idle + Bluetooth Link + WLAN (2.4GHz) Link + MP3 + Earphone + USB Cable (Charging from Adapter)		

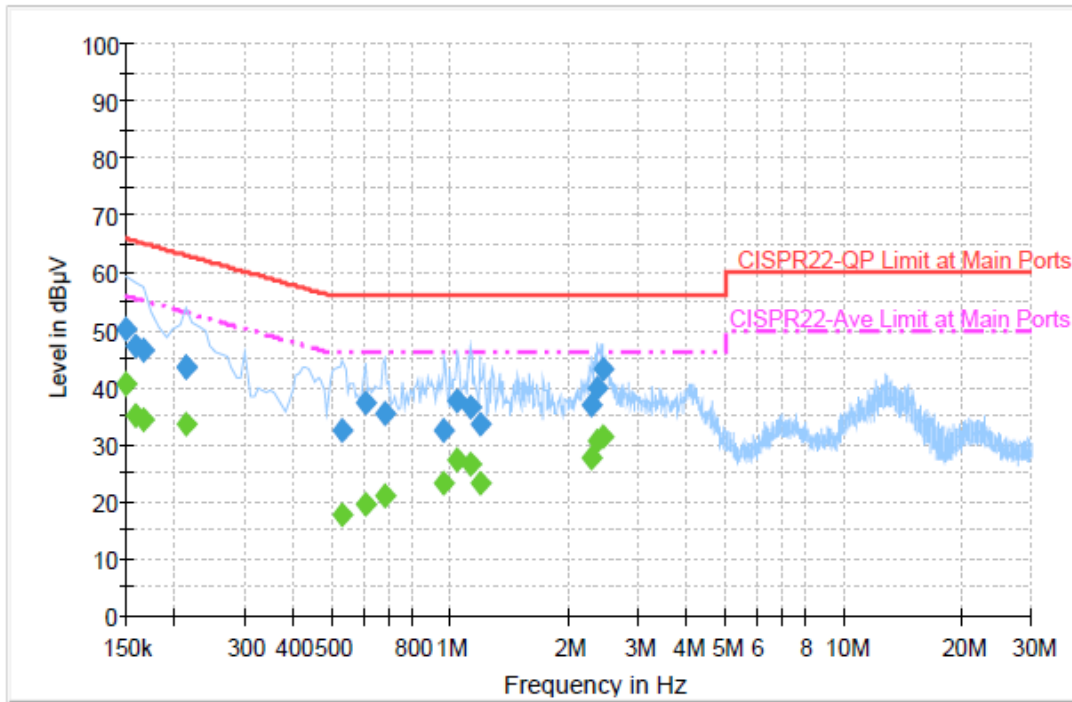

Final Result : Average

Frequency (MHz)	Average (dBµV)	Filter	Line	Corr. (dB)	Margin (dB)	Limit (dBµV)
0.150000	40.5	Off	N	19.4	15.5	56.0
0.158000	35.2	Off	N	19.4	20.4	55.6
0.166000	34.2	Off	N	19.4	21.0	55.2
0.214000	33.6	Off	N	19.4	19.4	53.0
0.534000	17.6	Off	N	19.4	28.4	46.0
0.606000	19.4	Off	N	19.4	26.6	46.0
0.686000	20.9	Off	N	19.5	25.1	46.0
0.966000	23.1	Off	N	19.4	22.9	46.0
1.046000	27.4	Off	N	19.5	18.6	46.0
1.126000	26.4	Off	N	19.5	19.6	46.0
1.190000	23.1	Off	N	19.5	22.9	46.0
2.286000	27.8	Off	N	19.6	18.2	46.0
2.374000	30.4	Off	N	19.7	15.6	46.0
2.438000	31.2	Off	N	19.7	14.8	46.0



3.7 Antenna Requirements

3.7.1 Standard Applicable

If directional gain of transmitting antennas is greater than 6dBi, the power shall be reduced by the same level in dB comparing to gain minus 6dBi. The use of a permanently attached antenna or of an antenna that uses a unique coupling to the intentional radiator shall be considered sufficient to comply with the FCC rule.

3.7.2 Antenna Connected Construction

Non-standard connector used.

3.7.3 Antenna Gain

The antenna peak gain of EUT is less than 6 dBi. Therefore, it is not necessary to reduce maximum peak output power limit.



4 List of Measuring Equipment

Instrument	Manufacturer	Model No.	Serial No.	Characteristics	Calibration Date	Test Date	Due Date	Remark
Spectrum Analyzer	Rohde & Schwarz	FSP40	100055	9kHz~40GHz	Jun. 07, 2013	Jul. 15, 2013	Jun. 06, 2014	Conducted (TH02-HY)
Power Meter	Agilent	E4416A	GB412923 44	300MHz~40GHz	Feb. 05, 2013	Jul. 15, 2013	Feb. 04, 2014	Conducted (TH02-HY)
Power Sensor	Agilent	E9327A	US404415 48	300MHz~40GHz	Feb. 05, 2013	Jul. 15, 2013	Feb. 04, 2014	Conducted (TH02-HY)
EMI Test Receiver	Rohde & Schwarz	ESCS 30	100356	9kHz ~ 2.75GHz	Nov. 13, 2012	Jul. 18, 2013	Nov. 12, 2013	Conduction (CO05-HY)
Two-LISN (for auxiliary equipment)	Rohde & Schwarz	ENV216	100081	9kHz ~ 30MHz	Dec. 12, 2012	Jul. 18, 2013	Dec. 11, 2013	Conduction (CO05-HY)
Two-LISN	Rohde & Schwarz	ENV216	100080	9kHz ~ 30MHz	Dec. 06, 2012	Jul. 18, 2013	Dec. 05, 2013	Conduction (CO05-HY)
AC Power Source	APC	APC-1000W	N/A	N/A	N/A	Jul. 18, 2013	N/A	Conduction (CO05-HY)
Spectrum Analyzer	R&S	ESU26	100390	20Hz~26.5GHz	Dec. 14, 2012	Jul. 06, 2013 ~ Jul. 10, 2013	Dec. 13, 2013	Radiation (03CH08-HY)
Bilog Antenna	Schaffner	CBL6111C	2725	30MHz~2GHz	Oct. 06, 2012	Jul. 06, 2013 ~ Jul. 10, 2013	Oct. 05, 2013	Radiation (03CH08-HY)
Horn Antenna	ESCO	3117	66584	1GHz~18GHz	Aug. 10, 2012	Jul. 06, 2013 ~ Jul. 10, 2013	Aug. 09, 2013	Radiation (03CH08-HY)
SHF-EHF Horn Antenna	SCHWARZBE CK	BBHA 9170	BBHA9170 251	15GHz ~ 40GHz	Sep. 28, 2012	Jul. 06, 2013 ~ Jul. 10, 2013	Sep. 27, 2013	Radiation (03CH08-HY)
Preamplifier	COM-POWER	PA-103	161075	10Hz~1000MHz Gain:32dB	Feb. 26, 2013	Jul. 06, 2013 ~ Jul. 10, 2013	Feb. 25, 2014	Radiation (03CH08-HY)
Pre Amplifier	Agilent	8449B	3008A026 65	1GHz~26.5GHz	Aug. 28, 2012	Jul. 06, 2013 ~ Jul. 10, 2013	Aug. 27, 2013	Radiation (03CH08-HY)
Turn Table	HD	Deis HD 2000	420/611	0 ~ 360 degree	N/A	Jul. 06, 2013 ~ Jul. 10, 2013	N/A	Radiation (03CH08-HY)
Antenna Mast	HD	MA 240	240/666	1 m ~ 4 m	N/A	Jul. 06, 2013 ~ Jul. 10, 2013	N/A	Radiation (03CH08-HY)



5 Uncertainty of Evaluation

Uncertainty of Conducted Emission Measurement (150 kHz ~ 30 MHz)

Measuring Uncertainty for a Level of Confidence of 95% ($U = 2Uc(y)$)	2.26
---	------

Uncertainty of Radiated Emission Measurement (30 MHz ~ 1000 MHz)

Measuring Uncertainty for a Level of Confidence of 95% ($U = 2Uc(y)$)	2.54
---	------

Uncertainty of Radiated Emission Measurement (1 GHz ~ 40 GHz)

Measuring Uncertainty for a Level of Confidence of 95% ($U = 2Uc(y)$)	4.72
---	------