

FCC SAR Test Report

APPLICANT : LG Electronics Inc.
EQUIPMENT : Mobile Phone
BRAND NAME : LG
MODEL NAME : LG-D802, LG-D802T, LG-D802a
FCC ID : ZNFD802
STANDARD : FCC 47 CFR Part 2 (2.1093)
ANSI/IEEE C95.1-1992
IEEE 1528-2003
FCC OET Bulletin 65 Supplement C (Edition 01-01)

The product was completely tested on Jul. 05, 2013. We, SPORTON INTERNATIONAL INC., would like to declare that the tested sample has been evaluated in accordance with the procedures and shown the compliance with the applicable technical standards.

The test results in this report apply exclusively to the tested model / sample. Without written approval of SPORTON INTERNATIONAL INC., the test report shall not be reproduced except in full.

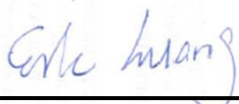

Reviewed by: Eric Huang / Deputy Manager



Approved by: Jones Tsai / Manager



SPORTON INTERNATIONAL INC.

No. 52, Hwa Ya 1st Rd., Hwa Ya Technology Park, Kwei-Shan Hsiang, Tao Yuan Hsien, Taiwan, R.O.C.



Table of Contents

1. Statement of Compliance 4
2. Administration Data 6
2.1 Testing Laboratory 6
2.2 Applicant 6
2.3 Manufacturer 6
2.4 Application Details 6
3. General Information 7
3.1 Description of Equipment Under Test (EUT) 7
3.2 Maximum RF output power among production units 8
3.3 Applied Standard 9
3.4 Device Category and SAR Limits 9
3.5 Test Conditions 9
4. Specific Absorption Rate (SAR) 10
4.1 Introduction 10
4.2 SAR Definition 10
5. SAR Measurement System 11
5.1 E-Field Probe 12
5.2 Data Acquisition Electronics (DAE) 13
5.3 Robot 14
5.4 Measurement Server 14
5.5 Phantom 15
5.6 Device Holder 16
5.7 Data Storage and Evaluation 17
5.8 Test Equipment List 19
6. Tissue Simulating Liquids 20
7. System Verification Procedures 22
7.1 Purpose of System Performance check 22
7.2 System Setup 22
7.3 SAR System Verification Results 23
8. EUT Testing Position 24
8.1 Define two imaginary lines on the handset 24
8.2 Cheek Position 25
8.3 Tilted Position 25
8.4 Body Worn Position 26
9. Measurement Procedures 27
9.1 Spatial Peak SAR Evaluation 27
9.2 Power Reference Measurement 28
9.3 Area & Zoom Scan Procedures 28
9.4 Volume Scan Procedures 29
9.5 SAR Averaged Methods 29
9.6 Power Drift Monitoring 29
10. Conducted RF Output Power (Unit: dBm) 30
11. Antenna Location 41
12. SAR Test Results 42
12.1 Test Records for Head SAR Test 42
12.2 Test Records for Hotspot SAR Test 44
12.3 Test Records for Body Worn SAR Test 45
12.4 Highest SAR Plot 46
13. Simultaneous Transmission Analysis 50
13.1 Head Exposure Conditions 51
13.2 Hotspot Exposure Conditions 54
13.3 Body-Worn Exposure Conditions 55
14. Uncertainty Assessment 57
15. References 60
Appendix A. Plots of System Performance Check
Appendix B. Plots of SAR Measurement
Appendix C. DASy Calibration Certificate
Appendix D. Test Setup Photos



Revision History

REPORT NO.	VERSION	DESCRIPTION	ISSUED DATE
FA362142	Rev. 01	Initial issue of report	Jul. 29, 2013



1. Statement of Compliance

The maximum results of Specific Absorption Rate (SAR) found during testing for **LG Electronics Inc. Mobile Phone, LG-D802, LG-D802T, LG-D802a** are as follows.

<Highest SAR Summary>

Exposure Position	Frequency Band	Reported 1g-SAR (W/kg)	Equipment Class	Highest Reported 1g-SAR (W/kg)
Head	GSM850	0.47	PCE	0.47
	GSM1900	0.14		
	WCDMA Band V	0.17		
	WCDMA Band II	0.15		
	WLAN 5.2GHz Band	0.04	NII	0.04
	WLAN 5.3GHz Band	0.01		
	WLAN 5.5GHz Band	0.02		
	WLAN 5.8GHz Band	0.16	DTS	0.50
	WLAN 2.4GHz Band	0.50		
Hotspot (Separation 1cm)	GPRS850	0.68	PCE	0.68
	GPRS1900	0.59		
	WCDMA Band V	0.38		
	WCDMA Band II	0.58		
	WLAN 2.4GHz Band	0.09	DTS	0.09
Body-worn (Separation 1cm)	GPRS850	0.69	PCE	0.69
	GPRS1900	0.55		
	WCDMA Band V	0.38		
	WCDMA Band II	0.54		
	WLAN 5.2GHz Band	0.04	NII	0.04
	WLAN 5.3GHz Band	0.03		
	WLAN 5.5GHz Band	0.02		
	WLAN 5.8GHz Band	0.06	DTS	0.09
	WLAN 2.4GHz Band	0.09		



<Highest Simultaneous transmission SAR>

Frequency Band	Equipment Class	Exposure Position	Highest Reported Simultaneous Transmission 1g-SAR (W/kg)
GSM850	PCE	Back	0.86
2.4GHz Bluetooth	DSS		

Frequency Band	Equipment Class	Exposure Position	Highest Reported Simultaneous Transmission 1g-SAR (W/kg)
GSM850	PCE	Right Cheek	0.97
WLAN 2.4GHz Band	DTS		

Frequency Band	Equipment Class	Exposure Position	Highest Reported Simultaneous Transmission 1g-SAR (W/kg)
GSM850	PCE	Back	0.73
WLAN 5.2GHz Band	NII		

This device is in compliance with Specific Absorption Rate (SAR) for general population/uncontrolled exposure limits (1.6 W/kg) specified in FCC 47 CFR part 2 (2.1093) and ANSI/IEEE C95.1-1992, and had been tested in accordance with the measurement methods and procedures specified in IEEE 1528-2003 and FCC OET Bulletin 65 Supplement C (Edition 01-01).



2. Administration Data

2.1 Testing Laboratory

Test Site	SPORTON INTERNATIONAL INC.
Test Site Location	No. 52, Hwa Ya 1 st Rd., Hwa Ya Technology Park, Kwei-Shan Hsiang, Tao Yuan Hsien, Taiwan, R.O.C. TEL: +886-3-327-3456 FAX: +886-3-328-4978

2.2 Applicant

Company Name	LG Electronics Inc.
Address	60-39, Kasan-dong, Kumchon-gu, Seoul 135-801, Korea

2.3 Manufacturer

Company Name	LG Electronics Inc.
Address	60-39, Kasan-dong, Kumchon-gu, Seoul 135-801, Korea

2.4 Application Details

Date of Start during the Test	Jun. 30, 2013
Date of End during the Test	Jul. 05, 2013



3. General Information

3.1 Description of Equipment Under Test (EUT)

Product Feature & Specification	
EUT	Mobile Phone
Brand Name	LG
Model Name	LG-D802, LG-D802T, LG-D802a
FCC ID	ZNFD802
IMEI Code	004402342882556
Wireless Technology and Frequency Range	GSM850: 824.2 MHz ~ 848.8 MHz GSM1900: 1850.2 MHz ~ 1909.8 MHz WCDMA Band V: 826.4 MHz ~ 846.6 MHz WCDMA Band II: 1852.4 MHz ~ 1907.6 MHz WLAN 2.4GHz Band: 2412 MHz ~ 2462 MHz WLAN 5.2GHz Band: 5180 MHz ~ 5240 MHz WLAN 5.3GHz Band: 5260 MHz ~ 5320 MHz WLAN 5.5GHz Band: 5500 MHz ~ 5700 MHz WLAN 5.8GHz Band: 5745 MHz ~ 5825 MHz Bluetooth: 2402 MHz ~ 2480 MHz NFC : 13.56 MHz
Mode	<ul style="list-style-type: none"> • GSM/GPRS/EGPRS • UMTS Rel 99 • HSDPA Rel 7, Cat14 • HSUPA Rel 6, Cat6 • DC-HSDPA Rel 8 Cat24 • 802.11a/b/g/n/ac HT20/HT40/VHT20/VHT40/VHT80 • Bluetooth 3.0 • Bluetooth 4.0+LE
Antenna Type	WWAN: PIFA Antenna WLAN: PIFA Antenna Bluetooth: PIFA Antenna NFC: Loop Antenna
HW Version	Rev.d
SW Version	D80207a
Dual Transfer Mode Category	Class A – EUT can support Packet Switched and Circuit Switched Network simultaneously.
EUT Stage	Production Unit
Remark:	<ol style="list-style-type: none"> 1. The above EUT's information was declared by manufacturer. Please refer to the specifications or user's manual for more detailed description. 2. Hotspot mode is supported in WLAN 2.4GHz frequency band, not supported in all 5GHz frequency bands. 3. WiFi direct (Group Owner/Group Client) is supported in 2.4GHz, and WiFi Direct (Group Client only) in 5180MHz ~ 5240MHz and 5745MHz ~5805MHz. 4. 802.11n- HT40 is not supported in 2.4GHz frequency band 5. This device supports DTM operation up to class11 and GPRS/EGPRS mode up to class12. 6. This device supported VoIP in WCDMA, GSM (e.g. 3rd part VoIP). 7. WLAN operation in 5600 MHz ~ 5650 MHz is notched.

3.2 Maximum RF output power among production units

Mode / Band		Burst average power(dBm)	
		GSM 850	GSM 1900
GSM (GMSK, 1 Tx slot)		33.7	30.7
GPRS/EDGE (GMSK, 1 Tx slot)		33.7	30.7
GPRS/EDGE (GMSK, 2 Tx slots)		31.7	29.7
GPRS/EDGE (GMSK, 3 Tx slots)		29.7	27.7
GPRS/EDGE (GMSK, 4 Tx slots)		28.2	26.2
EDGE (8PSK, 1 Tx slot)		27.8	26.7
EDGE (8PSK, 2 Tx slots)		27.7	26.7
EDGE (8PSK, 3 Tx slots)		26.7	25.7
EDGE (8PSK, 4 Tx slots)		25.7	24.7
DTM5(2Txslots)	GSM (GMSK, 1 Tx slot)	31.7	29.7
	GPRS (GMSK, 1 Tx slot)	31.7	29.7
DTM9(2Txslots)	GSM (GMSK, 1 Tx slot)	31.7	29.7
	GPRS (GMSK, 1 Tx slot)	31.7	29.7
DTM11(3Txslots)	GSM (GMSK, 1 Tx slot)	29.7	27.7
	GPRS (GMSK, 2 Tx slots)	29.7	27.7
DTM 5(2Tx slots)	GSM (GMSK, 1 Tx slot)	31.7	29.7
	EDGE (8PSK, 1 Tx slot)	27.7	26.7
DTM 9(2Tx slots)	GSM (GMSK, 1 Tx slot)	31.7	29.7
	EDGE (8PSK, 1 Tx slot)	27.7	26.7
DTM11(3Txslots)	GSM (GMSK, 1 Tx slot)	29.7	27.7
	EDGE (8PSK, 2 Tx slots)	26.7	25.7

Mode / Band	average power(dBm)	
	WCDMA Band V	WCDMA Band II
RMC 12.2Kbps	23.7	23.7
HSDPA Subtest-1	23.7	23.7
DC-HSDPA Subtest-1	23.7	23.7
HSUPA Subtest-5	23.7	23.7

IEEE 802.11 average power(dBm)								
Mode/Band	11b	11g	11a	HT20	HT40	VHT20	VHT40	VHT80
WLAN 2.4 GHz Band	17.0	14.0		13.0		12.0		
WLAN 5.2 GHz Band			13.5	12.6	12.6	11.5	11.5	11.5
WLAN 5.3 GHz Band			13.5	12.6	12.6	11.5	11.5	11.5
WLAN 5.5 GHz Band			13.5	12.6	12.6	11.5	11.5	11.5
WLAN 5.8 GHz Band			13.5	12.6	12.6	11.5	11.5	11.5

Mode / Band	Average power(dBm)
2.4 GHz Bluetooth	9



3.3 Applied Standard

The Specific Absorption Rate (SAR) testing specification, method, and procedure for this device is in accordance with the following standards:

- FCC 47 CFR Part 2 (2.1093)
- ANSI/IEEE C95.1-1992
- IEEE 1528-2003
- FCC OET Bulletin 65 Supplement C (Edition 01-01)
- FCC KDB 447498 D01 v05r01
- FCC KDB 648474 D04 v01r01
- FCC KDB 248227 D01 v01r02
- FCC KDB 644545 D01 v01r01
- FCC KDB 941225 D01 v02
- FCC KDB 941225 D02 v02r02
- FCC KDB 941225 D03 v01
- FCC KDB 941225 D04 v01
- FCC KDB 941225 D06 v01r01

3.4 Device Category and SAR Limits

This device belongs to portable device category because its radiating structure is allowed to be used within 20 centimeters of the body of the user. Limit for General Population/Uncontrolled exposure should be applied for this device, it is 1.6 W/kg as averaged over any 1 gram of tissue.

3.5 Test Conditions

3.5.1 Ambient Condition

Ambient Temperature	20 to 24 °C
Humidity	< 60 %

3.5.2 Test Configuration

For WWAN SAR testing, the device was controlled by using a base station emulator. Communication between the device and the emulator was established by air link. The distance between the EUT and the antenna of the emulator is larger than 50 cm and the output power radiated from the emulator antenna is at least 30 dB smaller than the output power of EUT.

During WLAN SAR testing EUT is configured with the WLAN continuous TX tool, and the transmission duty factor was monitored on the spectrum analyzer with zero-span setting

Duty factor observed as below:

- 802.11b, 1Mbps: 99.11%
- 802.11a, 6Mbps: 95.39%
- 802.11n-VHT80, MCS0: 82.27%

For WLAN SAR testing, WLAN engineering testing software installed on the EUT can provide continuous transmitting RF signal.

4. Specific Absorption Rate (SAR)

4.1 Introduction

SAR is related to the rate at which energy is absorbed per unit mass in an object exposed to a radio field. The SAR distribution in a biological body is complicated and is usually carried out by experimental techniques or numerical modeling. The standard recommends limits for two tiers of groups, occupational/controlled and general population/uncontrolled, based on a person's awareness and ability to exercise control over his or her exposure. In general, occupational/controlled exposure limits are higher than the limits for general population/uncontrolled.

4.2 SAR Definition

The SAR definition is the time derivative (rate) of the incremental energy (dW) absorbed by (dissipated in) an incremental mass (dm) contained in a volume element (dv) of a given density (ρ). The equation description is as below:

$$\text{SAR} = \frac{d}{dt} \left(\frac{dW}{dm} \right) = \frac{d}{dt} \left(\frac{dW}{\rho dv} \right)$$

SAR is expressed in units of Watts per kilogram (W/kg)

SAR measurement can be either related to the temperature elevation in tissue by

$$\text{SAR} = C \left(\frac{\delta T}{\delta t} \right)$$

Where: C is the specific heat capacity, δT is the temperature rise and δt is the exposure duration, or related to the electrical field in the tissue by

$$\text{SAR} = \frac{\sigma |E|^2}{\rho}$$

Where: σ is the conductivity of the tissue, ρ is the mass density of the tissue and E is the RMS electrical field strength.

However for evaluating SAR of low power transmitter, electrical field measurement is typically applied.

5. SAR Measurement System

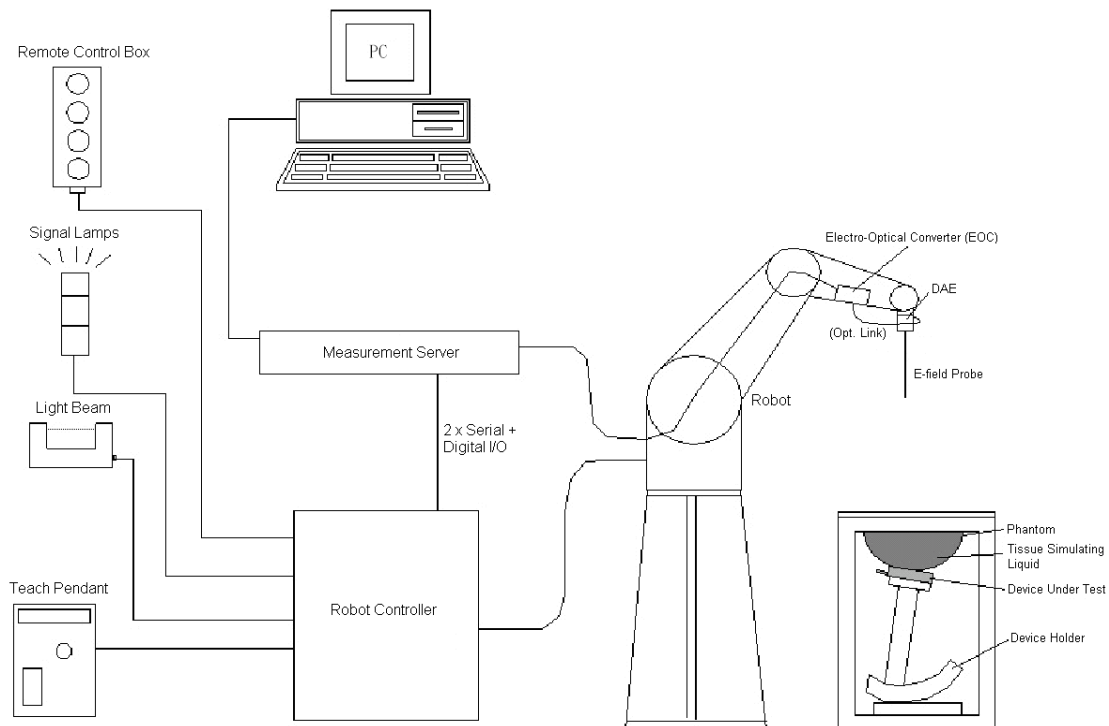

Fig 5.1 SPEAG DASY System Configurations

The DASY system for performance compliance tests is illustrated above graphically. This system consists of the following items:

- A standard high precision 6-axis robot with controller, a teach pendant and software
- A data acquisition electronic (DAE) attached to the robot arm extension
- A dosimetric probe equipped with an optical surface detector system
- The electro-optical converter (EOC) performs the conversion between optical and electrical signals
- A measurement server performs the time critical tasks such as signal filtering, control of the robot operation and fast movement interrupts.
- A probe alignment unit which improves the accuracy of the probe positioning
- A computer operating Windows XP
- DASY software
- Remote control with teach pendant and additional circuitry for robot safety such as warning lamps, etc.
- The SAM twin phantom
- A device holder
- Tissue simulating liquid
- Dipole for evaluating the proper functioning of the system

Component details are described in in the following sub-sections.

5.1 E-Field Probe

The SAR measurement is conducted with the dosimetric probe (manufactured by SPEAG). The probe is specially designed and calibrated for use in liquid with high permittivity. The dosimetric probe has special calibration in liquid at different frequency. This probe has a built in optical surface detection system to prevent from collision with phantom.

5.1.1 E-Field Probe Specification

<ET3DV6 Probe >

Construction	Symmetrical design with triangular core Built-in optical fiber for surface detection system. Built-in shielding against static charges. PEEK enclosure material (resistant to organic solvents, e.g., DGBE)
Frequency	10 MHz to 3 GHz; Linearity: ± 0.2 dB
Directivity	± 0.2 dB in HSL (rotation around probe axis) ± 0.4 dB in HSL (rotation normal to probe axis)
Dynamic Range	5 μ W/g to 100 mW/g; Linearity: ± 0.2 dB
Dimensions	Overall length: 330 mm (Tip: 16 mm) Tip diameter: 6.8 mm (Body: 12 mm) Distance from probe tip to dipole centers: 2.7 mm



Fig 5.2 Photo of ET3DV6

<ES3DV3 Probe >

Construction	Symmetrical design with triangular core Built-in optical fiber for surface detection system. Built-in shielding against static charges. PEEK enclosure material (resistant to organic solvents, e.g., DGBE)
Frequency	10 MHz to 3 GHz; Linearity: ± 0.2 dB
Directivity	± 0.2 dB in HSL (rotation around probe axis) ± 0.4 dB in HSL (rotation normal to probe axis)
Dynamic Range	10 μ W/g to 100 mW/g; Linearity: ± 0.2 dB
Dimensions	Overall length: 337 mm (Tip: 10 mm) Tip diameter: 4 mm (Body: 10 mm) Distance from probe tip to dipole centers: 3 mm



Fig 5.3 Photo of ES3DV3

<EX3DV4 Probe>

Construction	Symmetrical design with triangular core Built-in shielding against static charges PEEK enclosure material (resistant to organic solvents, e.g., DGBE)
Frequency	10 MHz to 6 GHz; Linearity: ± 0.2 dB
Directivity	± 0.3 dB in HSL (rotation around probe axis) ± 0.5 dB in tissue material (rotation normal to probe axis)
Dynamic Range	10 μ W/g to 100 mW/g; Linearity: ± 0.2 dB (noise: typically < 1 μ W/g)
Dimensions	Overall length: 330 mm (Tip: 20 mm) Tip diameter: 2.5 mm (Body: 12 mm) Typical distance from probe tip to dipole centers: 1 mm

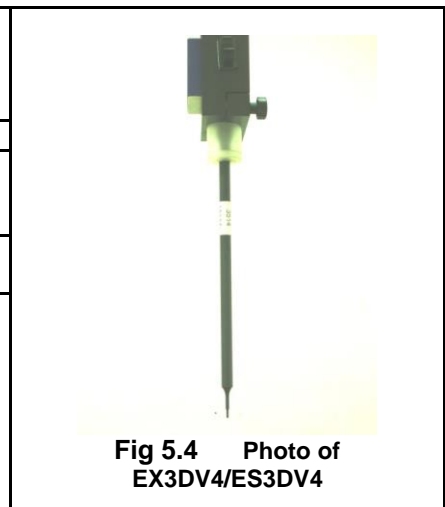

Fig 5.4 Photo of EX3DV4/ES3DV4

5.1.2 E-Field Probe Calibration

Each probe needs to be calibrated according to a dosimetric assessment procedure with accuracy better than $\pm 10\%$. The spherical isotropy shall be evaluated and within ± 0.25 dB. The sensitivity parameters (NormX, NormY, and NormZ), the diode compression parameter (DCP) and the conversion factor (ConvF) of the probe are tested. The calibration data can be referred to appendix C of this report.

5.2 Data Acquisition Electronics (DAE)

The data acquisition electronics (DAE) consists of a highly sensitive electrometer-grade preamplifier with auto-zeroing, a channel and gain-switching multiplexer, a fast 16 bit AD-converter and a command decoder and control logic unit. Transmission to the measurement server is accomplished through an optical downlink for data and status information as well as an optical uplink for commands and the clock. The input impedance of the DAE is 200 MOhm; the inputs are symmetrical and floating. Common mode rejection is above 80 dB.



Fig 5.5 Photo of DAE

5.3 Robot

The SPEAG DASY system uses the high precision robots (DASY4: RX90BL; DASY5: TX90XL) type from Stäubli SA (France). For the 6-axis controller system, the robot controller version (DASY4: CS7MB; DASY5: CS8c) from Stäubli is used. The Stäubli robot series have many features that are important for our application:

- High precision (repeatability ± 0.035 mm)
- High reliability (industrial design)
- Jerk-free straight movements
- Low ELF interference (the closed metallic construction shields against motor control fields)



Fig 5.6 Photo of DASY4



Fig 5.7 Photo of DASY5

5.4 Measurement Server

The measurement server is based on a PC/104 CPU board with CPU (DASY4: 166 MHz, Intel Pentium; DASY5: 400 MHz, Intel Celeron), chipdisk (DASY4: 32 MB; DASY5: 128 MB), RAM (DASY4: 64 MB, DASY5: 128 MB). The necessary circuits for communication with the DAE electronic box, as well as the 16 bit AD converter system for optical detection and digital I/O interface are contained on the DASY I/O board, which is directly connected to the PC/104 bus of the CPU board.

The measurement server performs all the real-time data evaluation for field measurements and surface detection, controls robot movements and handles safety operations.



Fig 5.8 Photo of Server for DASY4



Fig 5.9 Photo of Server for DASY5

5.5 Phantom

<SAM Twin Phantom>

Shell Thickness	2 ± 0.2 mm; Center ear point: 6 ± 0.2 mm
Filling Volume	Approx. 25 liters
Dimensions	Length: 1000 mm; Width: 500 mm; Height: adjustable feet
Measurement Areas	Left Hand, Right Hand, Flat Phantom



Fig 5.10 Photo of SAM Phantom

The bottom plate contains three pair of bolts for locking the device holder. The device holder positions are adjusted to the standard measurement positions in the three sections. A white cover is provided to tap the phantom during off-periods to prevent water evaporation and changes in the liquid parameters. On the phantom top, three reference markers are provided to identify the phantom position with respect to the robot.

<ELI4 Phantom>

Shell Thickness	2 ± 0.2 mm (sagging: <1%)
Filling Volume	Approx. 30 liters
Dimensions	Major ellipse axis: 600 mm Minor axis: 400 mm



Fig 5.11 Photo of ELI4 Phantom

The ELI4 phantom is intended for compliance testing of handheld and body-mounted wireless devices in the frequency range of 30 MHz to 6 GHz. ELI4 is fully compatible with standard and all known tissue simulating liquids.

5.6 Device Holder

<Device Holder for SAM Twin Phantom>

The SAR in the phantom is approximately inversely proportional to the square of the distance between the source and the liquid surface. For a source at 5 mm distance, a positioning uncertainty of ± 0.5 mm would produce a SAR uncertainty of ± 20 %. Accurate device positioning is therefore crucial for accurate and repeatable measurements. The positions in which the devices must be measured are defined by the standards.

The DASY device holder is designed to cope with different positions given in the standard. It has two scales for the device rotation (with respect to the body axis) and the device inclination (with respect to the line between the ear reference points). The rotation center for both scales is the ear reference point (ERP). Thus the device needs no repositioning when changing the angles.

The DASY device holder is constructed of low-loss POM material having the following dielectric parameters: relative permittivity $\epsilon = 3$ and loss tangent $\delta = 0.02$. The amount of dielectric material has been reduced in the closest vicinity of the device, since measurements have suggested that the influence of the clamp on the test results could thus be lowered.



Fig 5.12 Device Holder

<Laptop Extension Kit>

The extension is lightweight and made of POM, acrylic glass and foam. It fits easily on the upper part of the mounting device in place of the phone positioned. The extension is fully compatible with the SAM Twin and ELI phantoms.

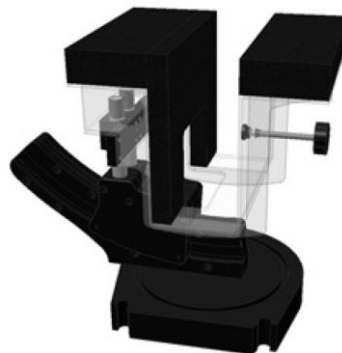

Fig 5.13 Laptop Extension Kit



5.7 Data Storage and Evaluation

5.7.1 Data Storage

The DASY software stores the assessed data from the data acquisition electronics as raw data (in microvolt readings from the probe sensors), together with all the necessary software parameters for the data evaluation (probe calibration data, liquid parameters and device frequency and modulation data) in measurement files. The post-processing software evaluates the desired unit and format for output each time the data is visualized or exported. This allows verification of the complete software setup even after the measurement and allows correction of erroneous parameter settings. For example, if a measurement has been performed with an incorrect crest factor parameter in the device setup, the parameter can be corrected afterwards and the data can be reevaluated.

The measured data can be visualized or exported in different units or formats, depending on the selected probe type (e.g., [V/m], [A/m], [mW/g]). Some of these units are not available in certain situations or give meaningless results, e.g., a SAR-output in a non-loss media, will always be zero. Raw data can also be exported to perform the evaluation with other software packages.

5.7.2 Data Evaluation

The DASY post-processing software (SEMCAD) automatically executes the following procedures to calculate the field units from the microvolt readings at the probe connector. The parameters used in the evaluation are stored in the configuration modules of the software :

Probe parameters :	- Sensitivity	Norm _i , a _{i0} , a _{i1} , a _{i2}
	- Conversion factor	ConvF _i
	- Diode compression point	dcp _i
Device parameters :	- Frequency	f
	- Crest factor	cf
Media parameters :	- Conductivity	σ
	- Density	ρ

These parameters must be set correctly in the software. They can be found in the component documents or they can be imported into the software from the configuration files issued for the DASY components. In the direct measuring mode of the multi-meter option, the parameters of the actual system setup are used. In the scan visualization and export modes, the parameters stored in the corresponding document files are used.

The first step of the evaluation is a linearization of the filtered input signal to account for the compression characteristics of the detector diode. The compensation depends on the input signal, the diode type and the DC-transmission factor from the diode to the evaluation electronics. If the exciting field is pulsed, the crest factor of the signal must be known to correctly compensate for peak power.



The formula for each channel can be given as :

$$V_i = U_i + U_i^2 \cdot \frac{cf}{dcp_i}$$

- with V_i = compensated signal of channel i, (i = x, y, z)
- U_i = input signal of channel i, (i = x, y, z)
- cf = crest factor of exciting field (DASY parameter)
- dcp_i = diode compression point (DASY parameter)

From the compensated input signals, the primary field data for each channel can be evaluated :

$$\text{E-field Probes : } E_i = \sqrt{\frac{V_i}{\text{Norm}_i \cdot \text{ConvF}}}$$

$$\text{H-field Probes : } H_i = \sqrt{V_i \cdot \frac{a_{i0} + a_{i1}f + a_{i2}f^2}{f}}$$

- with V_i = compensated signal of channel i, (i = x, y, z)
- Norm_i = sensor sensitivity of channel i, (i = x, y, z), $\mu\text{V}/(\text{V/m})^2$ for E-field Probes
- ConvF = sensitivity enhancement in solution
- a_{ij} = sensor sensitivity factors for H-field probes
- f = carrier frequency [GHz]
- E_i = electric field strength of channel i in V/m
- H_i = magnetic field strength of channel i in A/m

The RSS value of the field components gives the total field strength (Hermitian magnitude) :

$$E_{\text{tot}} = \sqrt{E_x^2 + E_y^2 + E_z^2}$$

The primary field data are used to calculate the derived field units.

$$\text{SAR} = E_{\text{tot}}^2 \cdot \frac{\sigma}{\rho \cdot 1000}$$

- with SAR = local specific absorption rate in mW/g
- E_{tot} = total field strength in V/m
- σ = conductivity in [mho/m] or [Siemens/m]
- ρ = equivalent tissue density in g/cm^3

Note that the density is set to 1, to account for actual head tissue density rather than the density of the tissue simulating liquid.



5.8 Test Equipment List

Manufacturer	Name of Equipment	Type/Model	Serial Number	Calibration	
				Last Cal.	Due Date
SPEAG	835MHz System Validation Kit	D835V2	499	Mar. 18, 2013	Mar. 19, 2014
SPEAG	1900MHz System Validation Kit	D1900V2	5d041	Mar. 20, 2013	Mar. 19, 2014
SPEAG	2450MHz System Validation Kit	D2450V2	736	Jul. 25, 2011	Jul. 24, 2013
SPEAG	5GHz System Validation Kit	D5GHzV2	1006	Dec. 11, 2012	Dec. 10, 2013
SPEAG	Data Acquisition Electronics	DAE3	577	May. 08, 2013	May. 07, 2014
SPEAG	Data Acquisition Electronics	DAE4	778	Aug. 27, 2012	Aug. 26, 2013
SPEAG	Data Acquisition Electronics	DAE4	1279	Jan. 28, 2013	Jan. 27, 2014
SPEAG	Data Acquisition Electronics	DAE4	1338	May. 28, 2013	May. 27, 2014
SPEAG	Dosimetric E-Field Probe	ET3DV6R	1788	Oct. 23, 2012	Oct. 22, 2013
SPEAG	Dosimetric E-Field Probe	EX3DV4	3697	Sep. 28, 2012	Sep. 27, 2013
SPEAG	Dosimetric E-Field Probe	EX3DV4	3792	Jun. 04, 2013	Jun. 03, 2014
SPEAG	Dosimetric E-Field Probe	ES3DV3	3270	Sep. 28, 2012	Sep. 27, 2013
Wisewind	Thermometer	ETP-101	TM560	Nov. 13, 2012	Nov. 12, 2013
Wisewind	Thermometer	ETP-101	TM685	Nov. 13, 2012	Nov. 12, 2013
Wisewind	Thermometer	HTC-1	TM642	Nov. 13, 2012	Nov. 12, 2013
Wisewind	Thermometer	HTC-1	TM281	Nov. 13, 2012	Nov. 12, 2013
Agilent	Wireless Communication Test Set	E5515C	MY50266977	May. 06, 2013	May. 05, 2015
SPEAG	Device Holder	N/A	N/A	NCR	NCR
Agilent	ESG Vector Series Signal Generator	E4438C	MY49070755	Oct. 02, 2012	Oct. 01, 2013
Agilent	ENA Network Analyzer	E5071C	MY46316648	Feb. 07, 2013	Feb. 06, 2014
Anritsu	Power Meter	ML2495A	1218006	Oct. 22, 2012	Oct. 21, 2013
Anritsu	Power Sensor	MA2411B	1207363	Oct. 24, 2012	Oct. 23, 2013
Agilent	Dual Directional Coupler	778D	50422	Note 4	
Woken	Attenuator 1	WK0602-XX	N/A	Note 4	
PE	Attenuator 2	PE7005-10	N/A	Note 4	
PE	Attenuator 3	PE7005-3	N/A	Note 4	
Agilent	Dielectric Probe Kit	85070D	US01440205	Note 5	
AR	Power Amplifier	5S1G4M2	328767	Note 6	
R&S	Spectrum Analyzer	FSP 40	100055	Jun. 07, 2013	Jun. 06, 2014

Table 5.1 Test Equipment List

Note:

1. The calibration certificate of DASY can be referred to appendix C of this report.
2. Referring to KDB 865664 D01v01r01, the dipole calibration interval can be extended to 3 years with justification. The dipoles are also not physically damaged, or repaired during the interval.
3. The justification data of dipole D2450V2, SN: 736 can be found in appendix C. The return loss is < -20dB, within 20% of prior calibration, the impedance is within 5 ohm of prior calibration.
4. The Insertion Loss calibration of Dual Directional Coupler and Attenuator were characterized via the network analyzer and compensated during system check.
5. The dielectric probe kit was calibrated via the network analyzer, with the specified procedure (calibrated in pure water) and calibration kit (standard) short circuit, before the dielectric measurement. The specific procedure and calibration kit are provided by Agilent.
6. In system check we need to monitor the level on the power meter, and adjust the power amplifier level to have precise power level to the dipole; the measured SAR will be normalized to 1W input power according to the ratio of 1W to the input power to the dipole. For system check, the calibration of the power amplifier is deemed not critically required for correct measurement; the power meter is critical and we do have calibration for it
7. Attenuator 1 insertion loss is calibrated by the network Analyzer, which the calibration is valid, before system check.

6. Tissue Simulating Liquids

For the measurement of the field distribution inside the SAM phantom with DASY, the phantom must be filled with around 25 liters of homogeneous body tissue simulating liquid. For head SAR testing, the liquid height from the ear reference point (ERP) of the phantom to the liquid top surface is larger than 15 cm, which is shown in Fig. 6.1. For body SAR testing, the liquid height from the center of the flat phantom to the liquid top surface is larger than 15 cm, which is shown in Fig. 6.2.

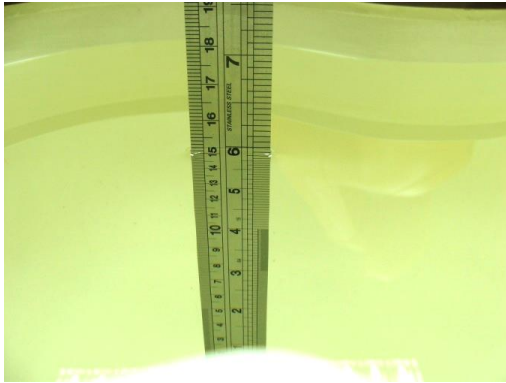

Fig 6.1 Photo of Liquid Height for Head SAR



Fig 6.2 Photo of Liquid Height for Body SAR

The following table gives the recipes for tissue simulating liquid.

Frequency (MHz)	Water (%)	Sugar (%)	Cellulose (%)	Salt (%)	Preventol (%)	DGBE (%)	Conductivity (σ)	Permittivity (ϵ_r)
For Head								
750	41.1	57.0	0.2	1.4	0.2	0	0.89	41.9
835	40.3	57.9	0.2	1.4	0.2	0	0.90	41.5
900	40.3	57.9	0.2	1.4	0.2	0	0.97	41.5
1800, 1900, 2000	55.2	0	0	0.3	0	44.5	1.40	40.0
2450	55.0	0	0	0	0	45.0	1.80	39.2
For Body								
750	51.7	47.2	0	0.9	0.1	0	0.96	55.5
835	50.8	48.2	0	0.9	0.1	0	0.97	55.2
900	50.8	48.2	0	0.9	0.1	0	1.05	55.0
1800, 1900, 2000	70.2	0	0	0.4	0	29.4	1.52	53.3
2450	68.6	0	0	0	0	31.4	1.95	52.7

Table 6.1 Recipes of Tissue Simulating Liquid

Simulating Liquid for 5G, Manufactured by SPEAG

Ingredients	(% by weight)
Water	64~78%
Mineral oil	11~18%
Emulsifiers	9~15%
Additives and Salt	2~3%



The dielectric parameters of the liquids were verified prior to the SAR evaluation using an Agilent 85070D Dielectric Probe Kit and an Agilent Network Analyzer.

The following table shows the measuring results for simulating liquid.

Frequency (MHz)	Liquid Type	Liquid Temp. (°C)	Conductivity (σ)	Permittivity (ϵ_r)	Conductivity Target (σ)	Permittivity Target (ϵ_r)	Delta (σ) (%)	Delta (ϵ_r) (%)	Limit (%)	Date
835	Body	21.6	0.963	54.529	0.97	55.2	-0.72	-1.22	±5	2013/7/1
835	Head	21.4	0.929	43.117	0.9	41.5	3.22	3.90	±5	2013/7/2
835	Head	21.4	0.916	41.7	0.9	41.5	1.78	0.48	±5	2013/7/3
1900	Body	21.5	1.548	52.144	1.52	53.3	1.84	-2.17	±5	2013/6/30
1900	Head	21.6	1.429	38.693	1.40	40.0	2.07	-3.27	±5	2013/7/1
2450	Head	21.2	1.85	39.3	1.80	39.2	2.78	0.26	±5	2013/7/3
2450	Body	21.5	2.02	53.9	1.95	52.7	3.59	2.28	±5	2013/7/4
5200	Body	22.4	5.257	47.536	5.30	49.0	-0.81	-2.99	±5	2013/7/4
5200	Head	22.4	4.485	37.46	4.66	36.0	-3.76	4.06	±5	2013/7/5
5300	Body	22.4	5.393	47.275	5.42	48.9	-0.50	-3.26	±5	2013/7/4
5300	Head	22.4	4.604	37.304	4.76	35.9	-3.28	4.00	±5	2013/7/5
5600	Body	22.4	5.79	46.784	5.77	48.47	0.35	-3.48	±5	2013/7/4
5600	Head	22.4	4.915	36.962	5.06	35.53	-2.87	4.03	±5	2013/7/5
5800	Body	22.4	6.144	46.942	6	48.2	2.40	-2.61	±5	2013/7/4
5800	Head	22.4	5.116	36.703	5.27	35.3	-2.92	3.97	±5	2013/7/5

Table 6.2 Measuring Results for Simulating Liquid

7. System Verification Procedures

Each DASY system is equipped with one or more system validation kits. These units, together with the predefined measurement procedures within the DASY software, enable the user to conduct the system performance check and system validation. System validation kit includes a dipole, tripod holder to fix it underneath the flat phantom and a corresponding distance holder.

7.1 Purpose of System Performance check

The system performance check verifies that the system operates within its specifications. System and operator errors can be detected and corrected. It is recommended that the system performance check be performed prior to any usage of the system in order to guarantee reproducible results. The system performance check uses normal SAR measurements in a simplified setup with a well characterized source. This setup was selected to give a high sensitivity to all parameters that might fail or vary over time. The system check does not intend to replace the calibration of the components, but indicates situations where the system uncertainty is exceeded due to drift or failure.

7.2 System Setup

In the simplified setup for system evaluation, the EUT is replaced by a calibrated dipole and the power source is replaced by a continuous wave that comes from a signal generator. The calibrated dipole must be placed beneath the flat phantom section of the SAM twin phantom with the correct distance holder. The distance holder should touch the phantom surface with a light pressure at the reference marking and be oriented parallel to the long side of the phantom. The equipment setup is shown below:

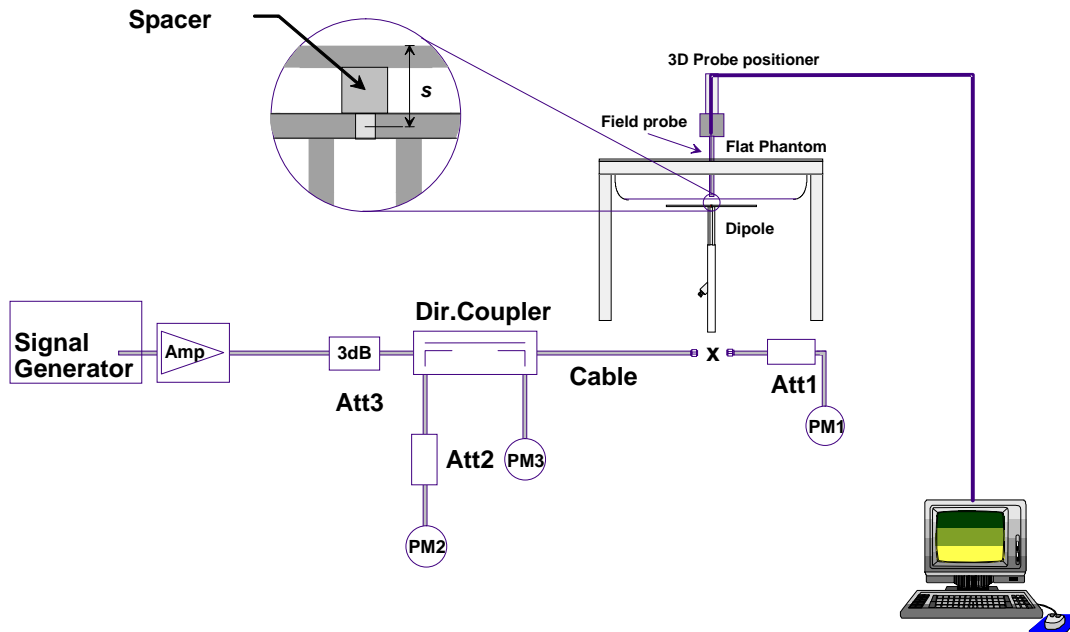

Fig 7.1 System Setup for System Evaluation

1. Signal Generator
2. Amplifier
3. Directional Coupler
4. Power Meter
5. Calibrated Dipole



Fig 7.2 Photo of Dipole Setup

7.3 SAR System Verification Results

Comparing to the original SAR value provided by SPEAG, the verification data should be within its specification of 10 %. Table 7.1 shows the target SAR and measured SAR after normalized to 1W input power. The table below indicates the system performance check can meet the variation criterion and the plots can be referred to Appendix A of this report.

Date	Frequency (MHz)	Liquid Type	Power fed onto reference dipole (mW)	Targeted SAR (W/kg)	Measured SAR (W/kg)	Normalized SAR (W/kg)	Deviation (%)
2013/7/1	835	Body	250	9.63	2.29	9.16	-4.88
2013/7/2	835	Head	250	9.57	2.42	9.68	1.15
2013/7/3	835	Head	250	9.57	2.5	10	4.49
2013/6/30	1900	Body	250	40.8	10.2	40.8	0.00
2013/7/1	1900	Head	250	40.6	9.67	38.68	-4.73
2013/7/3	2450	Head	250	54.8	14	56	2.19
2013/7/4	2450	Body	250	52.3	12.9	51.6	-1.34
2013/7/4	5200	Body	100	71.4	7.35	73.5	2.94
2013/7/5	5200	Head	100	79.80	7.51	75.1	-5.89
2013/7/4	5300	Body	100	73.5	7.87	78.7	7.07
2013/7/5	5300	Head	100	82.60	7.83	78.3	-5.21
2013/7/4	5600	Body	100	76.8	7.8	78	1.56
2013/7/5	5600	Head	100	83.60	8.14	81.4	-2.63
2013/7/4	5800	Body	100	71.7	7.09	70.9	-1.12
2013/7/5	5800	Head	100	78.90	7.64	76.4	-3.17

Table 7.1 Target and Measurement SAR after Normalized

8. EUT Testing Position

8.1 Define two imaginary lines on the handset

- The vertical centerline passes through two points on the front side of the handset - the midpoint of the width w_t of the handset at the level of the acoustic output, and the midpoint of the width w_b of the bottom of the handset.
- The horizontal line is perpendicular to the vertical centerline and passes through the center of the acoustic output. The horizontal line is also tangential to the face of the handset at point A.
- The two lines intersect at point A. Note that for many handsets, point A coincides with the center of the acoustic output; however, the acoustic output may be located elsewhere on the horizontal line. Also note that the vertical centerline is not necessarily parallel to the front face of the handset, especially for clamshell handsets, handsets with flip covers, and other irregularly shaped handsets.

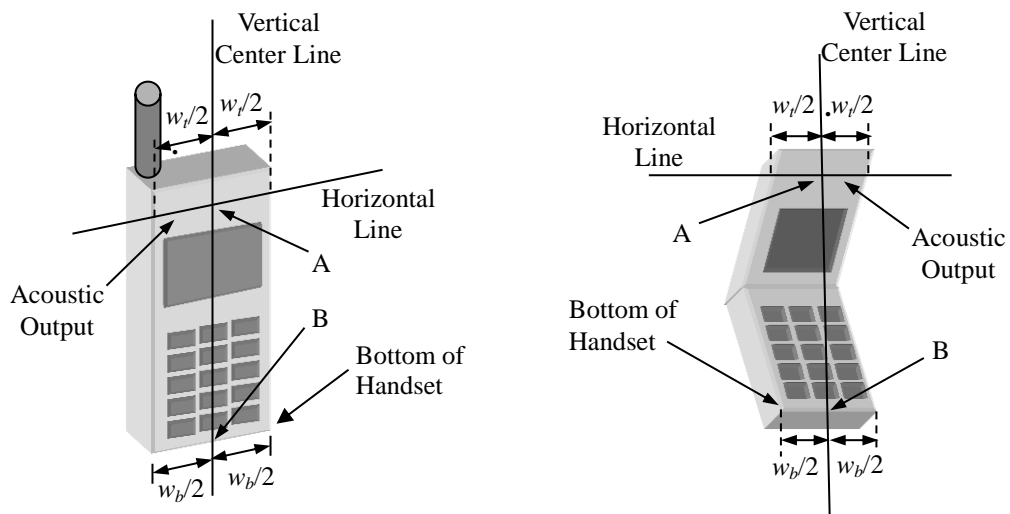

Fig 8.1 Illustration for Handset Vertical and Horizontal Reference Lines

8.2 Cheek Position

- (a) To position the device with the vertical center line of the body of the device and the horizontal line crossing the center piece in a plane parallel to the sagittal plane of the phantom. While maintaining the device in this plane, align the vertical center line with the reference plane containing the three ear and mouth reference point (M: Mouth, RE: Right Ear, and LE: Left Ear) and align the center of the ear piece with the line RE-LE.
- (b) To move the device towards the phantom with the ear piece aligned with the line LE-RE until the phone touched the ear. While maintaining the device in the reference plane and maintaining the phone contact with the ear, move the bottom of the phone until any point on the front side is in contact with the cheek of the phantom or until contact with the ear is lost (see Fig. 8.2).

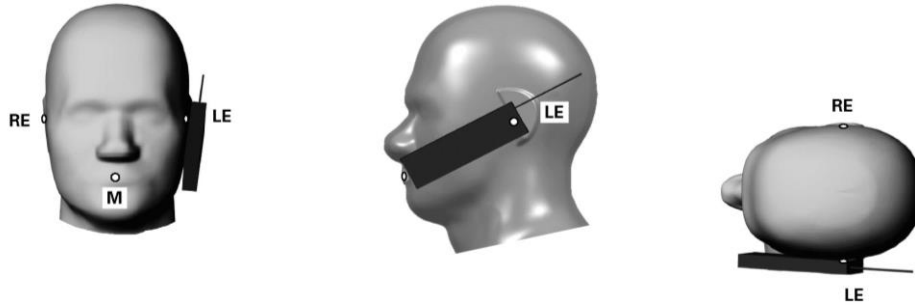

Fig 8.2 Illustration for Cheek Position

8.3 Tilted Position

- (a) To position the device in the “cheek” position described above.
- (b) While maintaining the device the reference plane described above and pivoting against the ear, moves it outward away from the mouth by an angle of 15 degrees or until contact with the ear is lost (see Fig. 8.3).

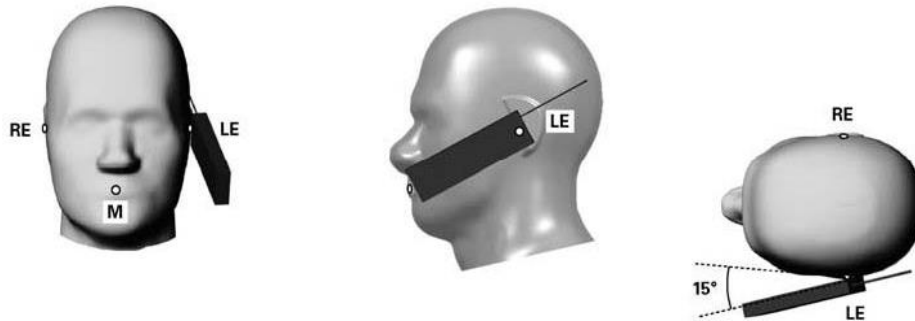

Fig 8.3 Illustration for Tilted Position

8.4 Body Worn Position

- (a) To position the device parallel to the phantom surface with either keypad up or down.
- (b) To adjust the device parallel to the flat phantom.
- (c) To adjust the distance between the device surface and the flat phantom to 1 cm.

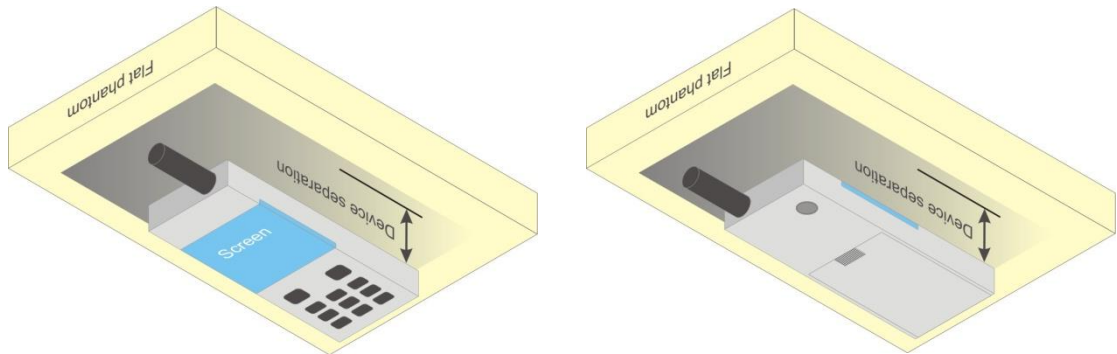

Fig 8.4 Illustration for Body Worn Position

8.5 Hotspot Position

- (a) To position the device parallel to the phantom surface with all sides and either keypad up or down.
- (b) To adjust the device parallel to the flat phantom.
- (c) To adjust the distance between the device and the flat phantom to 1.0cm.

<EUT Setup Photos>

Please refer to Appendix D for the test setup photos.



9. Measurement Procedures

The measurement procedures are as follows:

<Conducted power measurement>

- (a) For WWAN power measurement, use base station simulator to configure EUT WWAN transmission in conducted connection with RF cable, at maximum power in each supported wireless interface and frequency band.
- (b) Read the WWAN RF power level from the base station simulator.
- (c) For WLAN/BT power measurement, use engineering software to configure EUT WLAN/BT continuously transmission, at maximum RF power in each supported wireless interface and frequency band
- (d) Connect EUT RF port through RF cable to the power meter, and measure WLAN/BT output power

<SAR measurement>

- (a) Use base station simulator to configure EUT WWAN transmission in radiated connection, and engineering software to configure EUT WLAN/BT continuously transmission, at maximum RF power, in the highest power channel.
- (b) Place the EUT in the positions as Appendix D demonstrates.
- (c) Set scan area, grid size and other setting on the DASY software.
- (d) Measure SAR results for the highest power channel on each testing position.
- (e) Find out the largest SAR result on these testing positions of each band
- (f) Measure SAR results for other channels in worst SAR testing position if the reported SAR of highest power channel is larger than 0.8 W/kg

According to the test standard, the recommended procedure for assessing the peak spatial-average SAR value consists of the following steps:

- (a) Power reference measurement
- (b) Area scan
- (c) Zoom scan
- (d) Power drift measurement

9.1 Spatial Peak SAR Evaluation

The procedure for spatial peak SAR evaluation has been implemented according to the test standard. It can be conducted for 1g and 10g, as well as for user-specific masses. The DASY software includes all numerical procedures necessary to evaluate the spatial peak SAR value.

The base for the evaluation is a "cube" measurement. The measured volume must include the 1g and 10g cubes with the highest averaged SAR values. For that purpose, the center of the measured volume is aligned to the interpolated peak SAR value of a previously performed area scan.

The entire evaluation of the spatial peak values is performed within the post-processing engine (SEMCAD). The system always gives the maximum values for the 1g and 10g cubes. The algorithm to find the cube with highest averaged SAR is divided into the following stages:

- (a) Extraction of the measured data (grid and values) from the Zoom Scan
- (b) Calculation of the SAR value at every measurement point based on all stored data (A/D values and measurement parameters)
- (c) Generation of a high-resolution mesh within the measured volume
- (d) Interpolation of all measured values from the measurement grid to the high-resolution grid
- (e) Extrapolation of the entire 3-D field distribution to the phantom surface over the distance from sensor to surface
- (f) Calculation of the averaged SAR within masses of 1g and 10g

9.2 Power Reference Measurement

The Power Reference Measurement and Power Drift Measurements are for monitoring the power drift of the device under test in the batch process. The minimum distance of probe sensors to surface determines the closest measurement point to phantom surface. This distance cannot be smaller than the distance of sensor calibration points to probe tip as defined in the probe properties.

9.3 Area & Zoom Scan Procedures

First Area Scan is used to locate the approximate location(s) of the local peak SAR value(s). The measurement grid within an Area Scan is defined by the grid extent, grid step size and grid offset. Next, in order to determine the EM field distribution in a three-dimensional spatial extension, Zoom Scan is required. The Zoom Scan is performed around the highest E-field value to determine the averaged SAR-distribution over 10 g. Area scan and zoom scan resolution setting follows KDB 865664 D01v01r01 quoted below.

When the 1-g SAR of the highest peak is within 2 dB of the SAR limit, additional zoom scans are required for other peaks within 2 dB of the highest peak that have not been included in any zoom scan to ensure there is no increase in SAR.

		≤ 3 GHz	> 3 GHz	
Maximum distance from closest measurement point (geometric center of probe sensors) to phantom surface		5 ± 1 mm	$\frac{1}{2} \cdot \delta \cdot \ln(2) \pm 0.5$ mm	
Maximum probe angle from probe axis to phantom surface normal at the measurement location		$30^\circ \pm 1^\circ$	$20^\circ \pm 1^\circ$	
Maximum area scan spatial resolution: $\Delta x_{Area}, \Delta y_{Area}$		≤ 2 GHz: ≤ 15 mm 2 – 3 GHz: ≤ 12 mm	3 – 4 GHz: ≤ 12 mm 4 – 6 GHz: ≤ 10 mm	
		When the x or y dimension of the test device, in the measurement plane orientation, is smaller than the above, the measurement resolution must be \leq the corresponding x or y dimension of the test device with at least one measurement point on the test device.		
Maximum zoom scan spatial resolution: $\Delta x_{Zoom}, \Delta y_{Zoom}$		≤ 2 GHz: ≤ 8 mm 2 – 3 GHz: ≤ 5 mm*	3 – 4 GHz: ≤ 5 mm* 4 – 6 GHz: ≤ 4 mm*	
Maximum zoom scan spatial resolution, normal to phantom surface	uniform grid: $\Delta z_{Zoom}(n)$	≤ 5 mm	3 – 4 GHz: ≤ 4 mm 4 – 5 GHz: ≤ 3 mm 5 – 6 GHz: ≤ 2 mm	
	graded grid	$\Delta z_{Zoom}(1)$: between 1 st two points closest to phantom surface	≤ 4 mm	3 – 4 GHz: ≤ 3 mm 4 – 5 GHz: ≤ 2.5 mm 5 – 6 GHz: ≤ 2 mm
		$\Delta z_{Zoom}(n>1)$: between subsequent points	$\leq 1.5 \cdot \Delta z_{Zoom}(n-1)$	
Minimum zoom scan volume	x, y, z	≥ 30 mm	3 – 4 GHz: ≥ 28 mm 4 – 5 GHz: ≥ 25 mm 5 – 6 GHz: ≥ 22 mm	
<p>Note: δ is the penetration depth of a plane-wave at normal incidence to the tissue medium; see draft standard IEEE P1528-2011 for details.</p> <p>* When zoom scan is required and the <i>reported</i> SAR from the area scan based 1-g SAR estimation procedures of KDB 447498 is ≤ 1.4 W/kg, ≤ 8 mm, ≤ 7 mm and ≤ 5 mm zoom scan resolution may be applied, respectively, for 2 GHz to 3 GHz, 3 GHz to 4 GHz and 4 GHz to 6 GHz.</p>				



9.4 Volume Scan Procedures

The volume scan is used for assess overlapping SAR distributions for antennas transmitting in different frequency bands. It is equivalent to an oversized zoom scan used in standalone measurements. The measurement volume will be used to enclose all the simultaneous transmitting antennas. For antennas transmitting simultaneously in different frequency bands, the volume scan is measured separately in each frequency band. In order to sum correctly to compute the 1g aggregate SAR, the EUT remain in the same test position for all measurements and all volume scan use the same spatial resolution and grid spacing. When all volume scan were completed, the software, SEMCAD postprocessor can combine and subsequently superpose these measurement data to calculating the multiband SAR.

9.5 SAR Averaged Methods

In DASYS, the interpolation and extrapolation are both based on the modified Quadratic Shepard's method. The interpolation scheme combines a least-square fitted function method and a weighted average method which are the two basic types of computational interpolation and approximation.

Extrapolation routines are used to obtain SAR values between the lowest measurement points and the inner phantom surface. The extrapolation distance is determined by the surface detection distance and the probe sensor offset. The uncertainty increases with the extrapolation distance. To keep the uncertainty within 1% for the 1 g and 10 g cubes, the extrapolation distance should not be larger than 5 mm.

9.6 Power Drift Monitoring

All SAR testing is under the EUT install full charged battery and transmit maximum output power. In DASYS measurement software, the power reference measurement and power drift measurement procedures are used for monitoring the power drift of EUT during SAR test. Both these procedures measure the field at a specified reference position before and after the SAR testing. The software will calculate the field difference in dB. If the power drifts more than 5%, the SAR will be retested.

10. Conducted RF Output Power (Unit: dBm)

<GSM Conducted Power>

Note:

- For DTM multi-slot class mode, the device was linked with base station simulator (Agilent E5515C) and transmit maximum power on maximum number of TX slots, i.e. one CS timeslot, and additional PS timeslots (1 for DTM class 5 and 9, 2 for DTM class 11) in one TDMA frame.
- Agilent E5515C was used to setup the device operated under DTM mode for power measurement and SAR testing. For conducted power, the power of the burst for voice and the power of the bursts for data was reported separately in the table above, and the frame-average power is derived below to determine SAR testing.

$$DTM \text{ frame average power (dBm)} = 10 \cdot \log [\sum(\text{power of each slot, in mW})/8]$$
- Per KDB 447498 D01v05r01, the maximum output power channel is used for SAR testing and for further SAR test reduction.
- For head and body-worn SAR testing, GSM and DTM should be evaluated, therefore the EUT was set in DTM Multi-slot class 5 for GSM850/GSM1900 due to its highest frame-average power.
- For hotspot mode SAR testing, GPRS, EDGE and DTM should be evaluated, therefore the EUT was set in GPRS 2 Tx slots for GSM850/GSM1900 due to its highest frame-average power

Band GSM850		Burst Average Power (dBm)				Frame-Average Power (dBm)			
TX Channel		128	189	251	Tune-up Limit (dBm)	128	189	251	Tune-up Limit (dBm)
Frequency (MHz)		824.2	836.4	848.8		824.2	836.4	848.8	
GSM (GMSK, 1 Tx slot)		32.90	33.00	33.20	33.70	23.90	24.00	24.20	24.70
GPRS (GMSK, 1 Tx slot) – CS1		33.00	33.10	33.30	33.70	24.00	24.10	24.30	24.70
GPRS (GMSK, 2 Tx slots) – CS1		30.85	30.88	31.12	31.70	24.85	24.88	25.12	25.70
GPRS (GMSK, 3 Tx slots) – CS1		28.83	28.66	28.71	29.70	24.57	24.40	24.45	25.44
GPRS (GMSK, 4 Tx slots) – CS1		27.06	27.12	27.01	28.20	24.06	24.12	24.01	25.20
EDGE (GMSK, 1 Tx slot) – MCS1		32.98	33.09	33.29	33.70	23.98	24.09	24.29	24.70
EDGE (GMSK, 2 Tx slots) – MCS1		30.73	30.79	31.03	31.70	24.73	24.79	25.03	25.70
EDGE (GMSK, 3 Tx slots) – MCS1		28.74	28.57	28.65	29.70	24.48	24.31	24.39	25.44
EDGE (GMSK, 4 Tx slots) – MCS1		27.01	27.06	26.98	28.20	24.01	24.06	23.98	25.20
EDGE (8PSK, 1 Tx slot) – MCS5		27.62	27.68	27.70	27.80	18.62	18.68	18.70	18.80
EDGE (8PSK, 2 Tx slots) – MCS5		26.86	26.83	26.83	27.70	20.86	20.83	20.83	21.70
EDGE (8PSK, 3 Tx slots) – MCS5		25.66	25.61	25.58	26.70	21.40	21.35	21.32	22.44
EDGE (8PSK, 4 Tx slots) – MCS5		24.66	24.61	24.59	25.70	21.66	21.61	21.59	22.70
DTM 5 (2Tx slots)	GSM (GMSK, 1 Tx slot)	30.52	30.64	30.96	31.70	24.45	24.56	24.87	25.68
	GPRS (GMSK, 1 Tx slot) – CS1	30.42	30.53	30.83	31.70				
DTM 9 (2Tx slots)	GSM (GMSK, 1 Tx slot)	30.51	30.62	30.93	31.70	24.43	24.54	24.84	25.68
	GPRS (GMSK, 1 Tx slot) – CS1	30.40	30.51	30.80	31.70				
DTM 11 (3Tx slots)	GSM (GMSK, 1 Tx slot)	28.56	28.48	28.52	29.70	24.24	24.14	24.20	25.44
	GPRS (GMSK, 2 Tx slots) – CS1	28.47	28.36	28.43	29.70				
DTM 5 (2Tx slots)	GSM (GMSK, 1 Tx slot)	30.52	30.62	30.91	31.70	22.98	23.05	23.26	24.12
	EDGE (8PSK, 1 Tx slot) – MCS5	26.64	26.65	26.66	27.70				
DTM 9 (2Tx slots)	GSM (GMSK, 1 Tx slot)	30.50	30.61	30.90	31.70	22.96	23.04	23.25	24.12
	EDGE (8PSK, 1 Tx slot) – MCS5	26.62	26.64	26.65	27.70				
DTM 11 (3Tx slots)	GSM (GMSK, 1 Tx slot)	28.62	28.46	28.51	29.70	22.51	22.41	22.43	23.68
	EDGE (8PSK, 2 Tx slots) – MCS5	25.43	25.40	25.39	26.70				

Remark: The frame-averaged power is linearly scaled the maximum burst averaged power over 8 time slots.

The calculated method are shown as below:

Frame-averaged power = Maximum burst averaged power (1 Tx Slot) - 9 dB

Frame-averaged power = Maximum burst averaged power (2 Tx Slots) - 6 dB

Frame-averaged power = Maximum burst averaged power (3 Tx Slots) - 4.26 dB

Frame-averaged power = Maximum burst averaged power (4 Tx Slots) - 3 dB



Band GSM1900		Burst Average Power (dBm)				Frame-Average Power (dBm)			
TX Channel		512	661	810	Tune-up Limit (dBm)	512	661	810	Tune-up Limit (dBm)
Frequency (MHz)		1850.2	1880	1909.8		1850.2	1880	1909.8	
GSM (GMSK, 1 Tx slot)		30.20	30.10	30.00	30.70	21.20	21.10	21.00	21.70
GPRS (GMSK, 1 Tx slot) – CS1		30.21	30.20	30.00	30.70	21.20	21.20	21.00	21.70
GPRS (GMSK, 2 Tx slots) – CS1		29.44	29.28	29.28	29.70	23.44	23.28	23.28	23.70
GPRS (GMSK, 3 Tx slots) – CS1		27.01	26.93	26.91	27.70	22.75	22.67	22.65	23.44
GPRS (GMSK, 4 Tx slots) – CS1		25.55	25.52	25.47	26.20	22.55	22.52	22.47	23.20
EDGE (GMSK, 1 Tx slot) – MCS1		30.18	30.19	30.17	30.70	21.18	21.19	21.17	21.70
EDGE (GMSK, 2 Tx slots) – MCS1		29.38	29.23	29.25	29.70	23.38	23.23	23.25	23.70
EDGE (GMSK, 3 Tx slots) – MCS1		26.95	26.88	26.87	27.70	22.69	22.62	22.61	23.44
EDGE (GMSK, 4 Tx slots) – MCS1		25.54	25.51	25.45	26.20	22.54	22.51	22.45	23.20
EDGE (8PSK, 1 Tx slot) – MCS5		26.20	26.00	26.10	26.70	17.20	17.00	17.10	17.70
EDGE (8PSK, 2 Tx slots) – MCS5		26.14	26.08	26.07	26.70	20.14	20.08	20.07	20.70
EDGE (8PSK, 3 Tx slots) – MCS5		25.00	24.95	24.94	25.70	20.74	20.69	20.68	21.44
EDGE (8PSK, 4 Tx slots) – MCS5		23.84	23.78	23.79	24.70	20.84	20.78	20.79	21.70
DTM 5 (2Tx slots)	GSM (GMSK, 1 Tx slot)	29.40	29.26	29.28	29.70	23.34	23.20	23.22	23.68
	GPRS (GMSK, 1 Tx slot) – CS1	29.33	29.18	29.21	29.70				
DTM 9 (2Tx slots)	GSM (GMSK, 1 Tx slot)	29.37	29.25	29.26	29.70	23.32	23.18	23.21	23.68
	GPRS (GMSK, 1 Tx slot) – CS1	29.31	29.16	29.20	29.70				
DTM 11 (3Tx slots)	GSM (GMSK, 1 Tx slot)	26.97	26.90	26.91	27.70	22.64	22.59	22.61	23.44
	GPRS (GMSK, 2 Tx slots) – CS1	26.87	26.82	26.85	27.70				
DTM 5 (2Tx slots)	GSM (GMSK, 1 Tx slot)	29.27	29.14	29.18	29.70	21.93	21.83	21.85	22.43
	EDGE (8PSK, 1 Tx slot) – MCS5	26.04	26.00	26.00	26.70				
DTM 9 (2Tx slots)	GSM (GMSK, 1 Tx slot)	29.25	29.12	29.16	29.70	21.90	21.81	21.84	22.43
	EDGE (8PSK, 1 Tx slot) – MCS5	26.01	25.98	25.99	26.70				
DTM 11 (3Tx slots)	GSM (GMSK, 1 Tx slot)	26.88	26.82	26.81	27.70	21.40	21.35	21.35	22.21
	EDGE (8PSK, 2 Tx slots) – MCS5	24.89	24.85	24.86	25.70				

Remark: The frame-averaged power is linearly scaled the maximum burst averaged power over 8 time slots.
The calculated method are shown as below:
Frame-averaged power = Maximum burst averaged power (1 Tx Slot) - 9 dB
Frame-averaged power = Maximum burst averaged power (2 Tx Slots) - 6 dB
Frame-averaged power = Maximum burst averaged power (3 Tx Slots) - 4.26 dB
Frame-averaged power = Maximum burst averaged power (4 Tx Slots) - 3 dB

<WCDMA Conducted Power>

The following tests were conducted according to the test requirements outlines in 3GPP TS 34.121 specification.

A summary of these settings are illustrated below:

HSDPA Setup Configuration:

- a. The EUT was connected to Base Station Agilent E5515C referred to the Setup Configuration.
- b. The RF path losses were compensated into the measurements.
- c. A call was established between EUT and Base Station with following setting:
 - i. Set Gain Factors (β_c and β_d) and parameters were set according to each
 - ii. Specific sub-test in the following table, C10.1.4, quoted from the TS 34.121
 - iii. Set RMC 12.2Kbps + HSDPA mode.
 - iv. Set Cell Power = -86 dBm
 - v. Set HS-DSCH Configuration Type to FRC (H-set 1, QPSK)
 - vi. Select HSDPA Uplink Parameters
 - vii. Set Delta ACK, Delta NACK and Delta CQI = 8
 - viii. Set Ack-Nack Repetition Factor to 3
 - ix. Set CQI Feedback Cycle (k) to 4 ms
 - x. Set CQI Repetition Factor to 2
 - xi. Power Ctrl Mode = All Up bits
- d. The transmitted maximum output power was recorded.

Table C.10.1.4: β values for transmitter characteristics tests with HS-DPCCH

Sub-test	β_c	β_d	β_d (SF)	β_c/β_d	β_{HS} (Note 1, Note 2)	CM (dB) (Note 3)	MPR (dB) (Note 3)
1	2/15	15/15	64	2/15	4/15	0.0	0.0
2	12/15 (Note 4)	15/15 (Note 4)	64	12/15 (Note 4)	24/15	1.0	0.0
3	15/15	8/15	64	15/8	30/15	1.5	0.5
4	15/15	4/15	64	15/4	30/15	1.5	0.5

Note 1: $\Delta_{ACK}, \Delta_{NACK}$ and $\Delta_{CQI} = 30/15$ with $\beta_{HS} = 30/15 * \beta_c$.

Note 2: For the HS-DPCCH power mask requirement test in clause 5.2C, 5.7A, and the Error Vector Magnitude (EVM) with HS-DPCCH test in clause 5.13.1A, and HSDPA EVM with phase discontinuity in clause 5.13.1AA, Δ_{ACK} and $\Delta_{NACK} = 30/15$ with $\beta_{HS} = 30/15 * \beta_c$, and $\Delta_{CQI} = 24/15$ with $\beta_{HS} = 24/15 * \beta_c$.

Note 3: CM = 1 for $\beta_c/\beta_d = 12/15, \beta_{HS}/\beta_c = 24/15$. For all other combinations of DPDCH, DPCCH and HS-DPCCH the MPR is based on the relative CM difference. This is applicable for only UEs that support HSDPA in release 6 and later releases.

Note 4: For subtest 2 the β_c/β_d ratio of 12/15 for the TFC during the measurement period (TF1, TF0) is achieved by setting the signalled gain factors for the reference TFC (TF1, TF1) to $\beta_c = 11/15$ and $\beta_d = 15/15$.

Setup Configuration

HSUPA Setup Configuration:

- a. The EUT was connected to Base Station Agilent E5515C referred to the Setup Configuration.
- b. The RF path losses were compensated into the measurements.
- c. A call was established between EUT and Base Station with following setting * :
 - i. Call Configs = 5.2B, 5.9B, 5.10B, and 5.13.2B with QPSK
 - ii. Set the Gain Factors (β_c and β_d) and parameters (AG Index) were set according to each specific sub-test in the following table, C11.1.3, quoted from the TS 34.121
 - iii. Set Cell Power = -86 dBm
 - iv. Set Channel Type = 12.2k + HSPA
 - v. Set UE Target Power
 - vi. Power Ctrl Mode= Alternating bits
 - vii. Set and observe the E-TFCl
 - viii. Confirm that E-TFCl is equal to the target E-TFCl of 75 for sub-test 1, and other subtest's E-TFCl
- d. The transmitted maximum output power was recorded.

Table C.11.1.3: β values for transmitter characteristics tests with HS-DPCCH and E-DCH

Sub-test	β_c	β_d	β_d (SF)	β_c/β_d	β_{HS} (Note 1)	β_{ec}	β_{ed} (Note 5) (Note 6)	β_{ed} (SF)	β_{ed} (Codes)	CM (dB) (Note 2)	MPR (dB) (Note 2)	AG Index (Note 6)	E-TFCl
1	11/15 (Note 3)	15/15 (Note 3)	64	11/15 (Note 3)	22/15	209/225	1309/225	4	1	1.0	0.0	20	75
2	6/15	15/15	64	6/15	12/15	12/15	94/75	4	1	3.0	2.0	12	67
3	15/15	9/15	64	15/9	30/15	30/15	$\beta_{ed1}: 47/15$ $\beta_{ed2}: 47/15$	4	2	2.0	1.0	15	92
4	2/15	15/15	64	2/15	4/15	2/15	56/75	4	1	3.0	2.0	17	71
5	15/15 (Note 4)	15/15 (Note 4)	64	15/15 (Note 4)	30/15	24/15	134/15	4	1	1.0	0.0	21	81

Note 1: $\Delta_{ACK}, \Delta_{NACK}$ and $\Delta_{CQI} = 30/15$ with $\beta_{hs} = 30/15 * \beta_c$.

Note 2: CM = 1 for $\beta_c/\beta_d = 12/15, \beta_{hs}/\beta_c = 24/15$. For all other combinations of DPDCH, DPCCH, HS-DPCCH, E-DPDCH and E-DPCCH the MPR is based on the relative CM difference.

Note 3: For subtest 1 the β_c/β_d ratio of 11/15 for the TFC during the measurement period (TF1, TF0) is achieved by setting the signalled gain factors for the reference TFC (TF1, TF1) to $\beta_c = 10/15$ and $\beta_d = 15/15$.

Note 4: For subtest 5 the β_c/β_d ratio of 15/15 for the TFC during the measurement period (TF1, TF0) is achieved by setting the signalled gain factors for the reference TFC (TF1, TF1) to $\beta_c = 14/15$ and $\beta_d = 15/15$.

Note 5: In case of testing by UE using E-DPDCH Physical Layer category 1, Sub-test 3 is omitted according to TS25.306 Table 5.1g.

Note 6: β_{ed} can not be set directly, it is set by Absolute Grant Value.

Setup Configuration

DC-HSDPA 3GPP release 8 Setup Configuration:

- a. The EUT was connected to Base Station Agilent E5515C referred to the Setup Configuration below
- b. The RF path losses were compensated into the measurements.
- c. A call was established between EUT and Base Station with following setting:
 - i. Set RMC 12.2Kbps + HSDPA mode.
 - ii. Set Cell Power = -25 dBm
 - iii. Set HS-DSCH Configuration Type to FRC (H-set 12, QPSK)
 - iv. Select HSDPA Uplink Parameters
 - v. Set Gain Factors (β_c and β_d) and parameters were set according to each Specific sub-test in the following table, C10.1.4, quoted from the TS 34.121
 - a). Subtest 1: $\beta_c/\beta_d=2/15$
 - b). Subtest 2: $\beta_c/\beta_d=12/15$
 - c). Subtest 3: $\beta_c/\beta_d=15/8$
 - d). Subtest 4: $\beta_c/\beta_d=15/4$
 - vi. Set Delta ACK, Delta NACK and Delta CQI = 8
 - vii. Set Ack-Nack Repetition Factor to 3
 - viii. Set CQI Feedback Cycle (k) to 4 ms
 - ix. Set CQI Repetition Factor to 2
 - x. Power Ctrl Mode = All Up bits
- d. The transmitted maximum output power was recorded.

The following tests were conducted according to the test requirements outlines in 3GPP TS 34.121 specification. A summary of these settings are illustrated below:

C.8.1.12 Fixed Reference Channel Definition H-Set 12

Table C.8.1.12: Fixed Reference Channel H-Set 12

Parameter	Unit	Value
Nominal Avg. Inf. Bit Rate	kbps	60
Inter-TTI Distance	TTI's	1
Number of HARQ Processes	Processes	6
Information Bit Payload (N_{INF})	Bits	120
Number Code Blocks	Blocks	1
Binary Channel Bits Per TTI	Bits	960
Total Available SML's in UE	SML's	19200
Number of SML's per HARQ Proc.	SML's	3200
Coding Rate		0.15
Number of Physical Channel Codes	Codes	1
Modulation		QPSK
Note 1: The RMC is intended to be used for DC-HSDPA mode and both cells shall transmit with identical parameters as listed in the table. Note 2: Maximum number of transmission is limited to 1, i.e., retransmission is not allowed. The redundancy and constellation version 0 shall be used.		

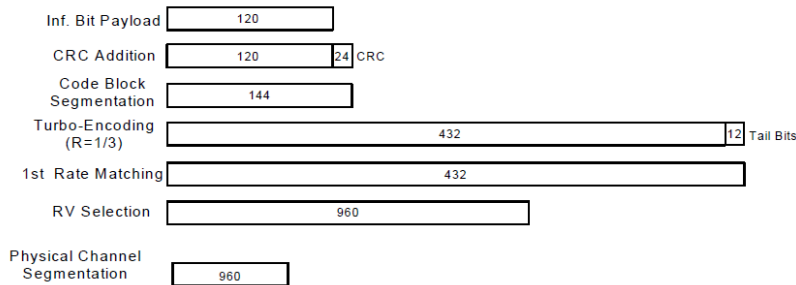

Figure C.8.19: Coding rate for Fixed reference Channel H-Set 12 (QPSK)

Setup Configuration



<WCDMA Conducted Power>

Note:

- Per KDB 941225 D01v02, RMC 12.2kbps setting is used to evaluate SAR. If AMR 12.2kbps power is < 0.25dB higher than RMC 12.2kbps, SAR tests with AMR 12.2kbps can be excluded.

Band			WCDMA V				WCDMA II			
TX Channel			4132	4182	4233	Tune-up Limit (dBm)	9262	9400	9538	Tune-up Limit (dBm)
Rx Channel			4357	4407	4458		9662	9800	9938	
Frequency (MHz)			826.4	836.4	846.6		1852.4	1880	1907.6	
3GPP MPR (dB)	3GPP Rel 99	AMR 12.2Kbps	23.48	23.37	23.36	23.70	23.27	23.08	23.07	23.70
	3GPP Rel 99	RMC 12.2Kbps	23.50	23.40	23.40	23.70	23.30	23.10	23.10	23.70
0	3GPP Rel 6	HSDPA Subtest-1	22.27	22.21	22.25	23.70	22.35	22.28	22.27	23.70
0	3GPP Rel 6	HSDPA Subtest-2	22.24	22.16	22.23	23.70	22.33	22.27	22.26	23.70
0.5	3GPP Rel 6	HSDPA Subtest-3	21.74	21.63	21.77	23.20	21.86	21.78	21.77	23.20
0.5	3GPP Rel 6	HSDPA Subtest-4	21.73	21.60	21.73	23.20	21.84	21.77	21.73	23.20
0	3GPP Rel 8	DC-HSDPA Subtest-1	22.24	22.18	22.26	23.70	22.30	22.24	22.25	23.70
0	3GPP Rel 8	DC-HSDPA Subtest-2	22.22	22.15	22.21	23.70	22.28	22.23	22.22	23.70
0.5	3GPP Rel 8	DC-HSDPA Subtest-3	21.71	21.61	21.75	23.20	21.84	21.76	21.74	23.20
0.5	3GPP Rel 8	DC-HSDPA Subtest-4	21.68	21.58	21.69	23.20	21.80	21.71	21.69	23.20
0	3GPP Rel 6	HSUPA Subtest-1	22.35	22.25	22.31	23.70	22.18	22.22	22.11	23.70
2	3GPP Rel 6	HSUPA Subtest-2	20.78	20.76	20.75	21.70	20.86	20.78	20.93	21.70
1	3GPP Rel 6	HSUPA Subtest-3	21.13	21.01	21.05	22.70	21.15	20.97	20.90	22.70
2	3GPP Rel 6	HSUPA Subtest-4	21.03	20.87	20.94	21.70	20.93	20.91	20.86	21.70
0	3GPP Rel 6	HSUPA Subtest-5	22.34	22.24	22.29	23.70	22.26	22.24	22.27	23.70



<WLAN 2.4GHz Conducted Power>

WLAN 2.4GHz 802.11b Average Power (dBm)							Tune-up Limit (dBm)
Power vs. Channel			Power vs. Data Rate				
Channel	Frequency (MHz)	Data Rate 1Mbps	Channel	2Mbps	5.5Mbps	11Mbps	
CH 1	2412	15.79	CH 11	15.76	15.77	15.89	17
CH 6	2437	15.68					
CH 11	2462	15.91					

WLAN 2.4GHz 802.11g Average Power (dBm)											Tune-up Limit (dBm)
Power vs. Channel			Power vs. Data Rate								
Channel	Frequency (MHz)	Data Rate 6Mbps	Channel	9Mbps	12Mbps	18Mbps	24Mbps	36Mbps	48Mbps	54Mbps	
CH 1	2412	12.35	CH 1	12.06	12.19	12.34	12.34	12.25	12.34	12.27	14
CH 6	2437	12.10									
CH 11	2462	12.08									

WLAN 2.4GHz 802.11n-HT20 Average Power (dBm)											Tune-up Limit (dBm)
Power vs. Channel			Power vs. MCS Index								
Channel	Frequency (MHz)	MCS Index MCS0	Channel	MCS1	MCS2	MCS3	MCS4	MCS5	MCS6	MCS7	
CH 1	2412	12.05	CH 1	12.04	12.04	11.97	11.99	12.03	12.01	12.01	13
CH 6	2437	11.94									
CH 11	2462	11.93									

WLAN 2.4GHz 802.11ac-VHT20 Average Power (dBm)												Tune-up Limit (dBm)
Power vs. Channel			Power vs. MCS Index									
Channel	Frequency (MHz)	MCS Index MCS0	Channel	MCS1	MCS2	MCS3	MCS4	MCS5	MCS6	MCS7	MCS8	
CH 1	2412	11.01	CH11	10.89	10.89	10.92	10.90	10.90	10.97	10.89	10.91	12
CH 6	2437	11.03										
CH 11	2462	11.05										

Note:

1. Per KDB 248227 D01 v01r02, choose the highest output power channel to test SAR and determine further SAR exclusion
2. For each frequency band, testing at higher data rates and higher order modulations is not required when the maximum average output power for each of these configurations is less than 1/4dB higher than those measured at the lowest data rate
3. Apply the test exclusion rule in KDB 248227 D01 v01r02, 11g, 11n-HT20 and 11ac-VHT20 output power is less than 1/4dB higher than 11b mode, thus the SAR can be excluded.



<Bluetooth Conducted Power>

Bluetooth average power (dBm)				
Mode	GFSK	$\pi/4$ -DQPSK	8-DPSK	BT v4.0 LE, GFSK
	8.46	5.57	5.56	3.58
Tune Up Limit (dBm)	9			

Note:

1. Per KDB 447498 D01v05r01, the 1-g and 10-g SAR test exclusion thresholds for 100 MHz to 6 GHz at test separation distances ≤ 50 mm are determined by:

$[(\text{max. power of channel, including tune-up tolerance, mW}) / (\text{min. test separation distance, mm})] \cdot [\sqrt{f(\text{GHz})}] \leq 3.0$ for 1-g SAR and ≤ 7.5 for 10-g extremity SAR

- f(GHz) is the RF channel transmit frequency in GHz
- Power and distance are rounded to the nearest mW and mm before calculation
- The result is rounded to one decimal place for comparison

Bluetooth Max Power (dBm)	mW	Test Distance (mm)	Frequency (GHz)	exclusion thresholds
9.0	7.94	5	2.48	2.50

2. Per KDB 447498 D01v05r01 exclusion thresholds is $2.50 < 3$, RF exposure evaluation is not required.



<WLAN 5GHz Conducted Power>

WLAN 5GHz 802.11a Average Power (dBm)											Tune-up Limit (dBm)
Power vs. Channel			Power vs. Data Rate								
Channel	Frequency (MHz)	Data Rate 6Mbps	Channel	9Mbps	12Mbps	18Mbps	24Mbps	36Mbps	48Mbps	54Mbps	
CH 36	5180	13.31	CH 36	12.95	12.97	12.86	12.82	12.80	12.88	12.77	13.5
CH 40	5200	12.86									
CH 44	5220	12.83									
CH 48	5240	12.67									
CH 52	5260	12.96	CH 52	12.89	12.83	12.95	12.72	12.80	12.76	12.71	
CH 56	5280	12.95									
CH 60	5300	12.71									
CH 64	5320	12.62									
CH 100	5500	12.69	CH 100	12.68	12.67	12.66	12.67	12.67	12.59	12.59	
CH 104	5520	12.68									
CH 108	5540	12.61									
CH 112	5560	12.58									
CH 116	5580	12.37									
CH 132	5660	12.14									
CH 136	5680	12.01									
CH 140	5700	11.76									
CH 144	5720	10.02	CH 149	12.05	12.07	12.07	12.05	12.08	12.08	12.08	
CH 149	5745	12.11									
CH 153	5765	12.08									
CH 157	5785	11.72									
CH 161	5805	11.98	CH 165	5825	11.79						
CH 165	5825	11.79									

WLAN 5GHz 802.11n-HT20 Average Power (dBm)											Tune-up Limit (dBm)
Power vs. Channel			Power vs. MCS Index								
Channel	Frequency (MHz)	MCS Index MCS0	Channel	MCS1	MCS2	MCS3	MCS4	MCS5	MCS6	MCS7	
CH 36	5180	12.06	CH 36	11.74	11.72	11.81	11.82	11.64	11.69	11.80	12.6
CH 40	5200	12.04									
CH 44	5220	11.78									
CH 48	5240	11.65									
CH 52	5260	11.97	CH 52	11.95	11.91	11.94	11.94	11.96	11.94	11.93	
CH 56	5280	11.95									
CH 60	5300	11.96									
CH 64	5320	11.77									
CH 100	5500	11.83	CH 100	11.81	11.82	11.81	11.80	11.77	11.81	11.82	
CH 104	5520	11.73									
CH 108	5540	11.54									
CH 112	5560	11.81									
CH 116	5580	11.58									
CH 132	5660	11.15									
CH 136	5680	11.13									
CH 140	5700	11.18									
CH 144	5720	9.26	CH 149	11.20	11.16	11.20	11.20	11.19	11.14	11.06	
CH 149	5745	11.21									
CH 153	5765	11.17									
CH 157	5785	11.01									
CH 161	5805	10.65	CH 165	5825	10.60						
CH 165	5825	10.60									



WLAN 5GHz 802.11n-HT40 Average Power (dBm)											
Power vs. Channel			Power vs. MCS Index								Tune-up Limit (dBm)
Channel	Frequency (MHz)	MCS Index MCS0	Channel	MCS1	MCS2	MCS3	MCS4	MCS5	MCS6	MCS7	
CH 38	5190	12.20	CH 38	12.18	11.93	12.15	12.19	12.18	12.18	12.13	12.6
CH 46	5230	11.86									
CH 54	5270	12.53									
CH 62	5310	11.97	CH 54	12.38	12.06	12.10	12.32	12.32	12.04	12.50	
CH 102	5510	12.19									
CH 110	5550	12.05									
CH 134	5670	11.49	CH 102	12.18	12.12	12.14	12.02	12.09	12.17	12.18	
CH 142	5710	10.44									
CH 151	5755	11.10									
CH 159	5795	10.90	CH 151	11.09	11.06	10.94	11.08	11.05	10.90	11.03	

WLAN 5GHz 802.11ac-VHT20 Average Power (dBm)											
Power vs. Channel			Power vs. MCS Index								Tune-up Limit (dBm)
Channel	Frequency (MHz)	MCS Index MCS0	Channel	MCS1	MCS2	MCS3	MCS4	MCS5	MCS6	MCS7	
CH 36	5180	11.06	CH 36	10.92	10.95	10.96	10.81	10.93	10.95	10.94	10.57
CH 40	5200	11.03									
CH 44	5220	10.61									
CH 48	5240	10.80									
CH 52	5260	10.94	CH 52	10.93	10.93	10.92	10.91	10.90	10.92	10.89	10.73
CH 56	5280	10.93									
CH 60	5300	10.86									
CH 64	5320	10.77									
CH 100	5500	10.81	CH 100	10.78	10.77	10.80	10.77	10.77	10.76	10.76	10.78
CH 104	5520	10.81									
CH 108	5540	10.80									
CH 112	5560	10.79									
CH 116	5580	10.55									
CH 132	5660	10.58									
CH 136	5680	10.51									
CH 140	5700	10.23									
CH 144	5720	8.43									
CH 149	5745	10.21									
CH 153	5765	10.15	CH 149	10.16	10.20	10.19	10.19	10.17	10.20	10.20	10.17
CH 157	5785	10.07									
CH 161	5805	9.73									
CH 165	5825	9.78									

WLAN 5GHz 802.11ac-VHT40 Average Power (dBm)												
Power vs. Channel			Power vs. MCS Index								Tune-up Limit (dBm)	
Channel	Frequency (MHz)	MCS Index MCS0	Channel	MCS1	MCS2	MCS3	MCS4	MCS5	MCS6	MCS7		MCS8
CH 38	5190	11.30	CH 38	11.14	11.26	11.01	10.94	11.26	11.08	11.24	10.85	11.29
CH 46	5230	10.96										
CH 54	5270	11.26	CH 54	11.20	11.25	11.21	11.25	11.14	11.24	11.23	11.01	11.24
CH 62	5310	11.12										
CH 102	5510	10.98	CH 102	10.91	10.86	10.96	10.72	10.82	10.96	10.96	10.97	10.94
CH 110	5550	10.94										
CH 134	5670	10.76										
CH 142	5710	9.43										
CH 151	5755	10.61										
CH 159	5795	9.60										
			CH 151	10.51	10.22	10.23	10.23	10.37	10.51	10.28	10.58	10.14



WLAN 5GHz 802.11ac-VHT80 Average Power (dBm)													Tune-up Limit (dBm)
Power vs. Channel			Power vs. MCS Index										
Channel	Frequency (MHz)	MCS Index MCS0	Channel	MCS1	MCS2	MCS3	MCS4	MCS5	MCS6	MCS7	MCS8	MCS9	
CH 42	5210	11.02	CH 42	10.98	10.99	10.97	10.97	11.01	10.83	10.82	10.77	10.99	11.5
CH 58	5290	10.81	CH 58	10.79	10.77	10.59	10.76	10.80	10.54	10.77	10.74	10.75	
CH 106	5530	10.87	CH 106	10.80	10.78	10.69	10.82	10.79	10.81	10.82	10.76	10.82	
CH 138	5690	10.35											
CH 155	5775	10.57	CH 155	10.52	10.37	10.53	10.51	10.51	10.46	10.54	10.36	10.44	

Note:

1. Per KDB 248227 D01 v01r02, choose the highest output power channel to test SAR and determine further SAR exclusion
2. For each frequency band, testing at higher data rates and higher order modulations is not required when the maximum average output power for each of these configurations is less than 1/4dB higher than those measured at the lowest data rate.
3. Apply the test exclusion rule in KDB 248227 D01 v01r02, 11n-HT20/HT40 and 11ac-VHT20/VHT40 output power is less than 1/4dB higher than 802.11a mode, thus the SAR can be excluded.
4. For 802.11ac SAR evaluation for each frequency band, 802.11ac-VHT80 was verified at the worst case found in 802.11a SAR testing.

11. Antenna Location

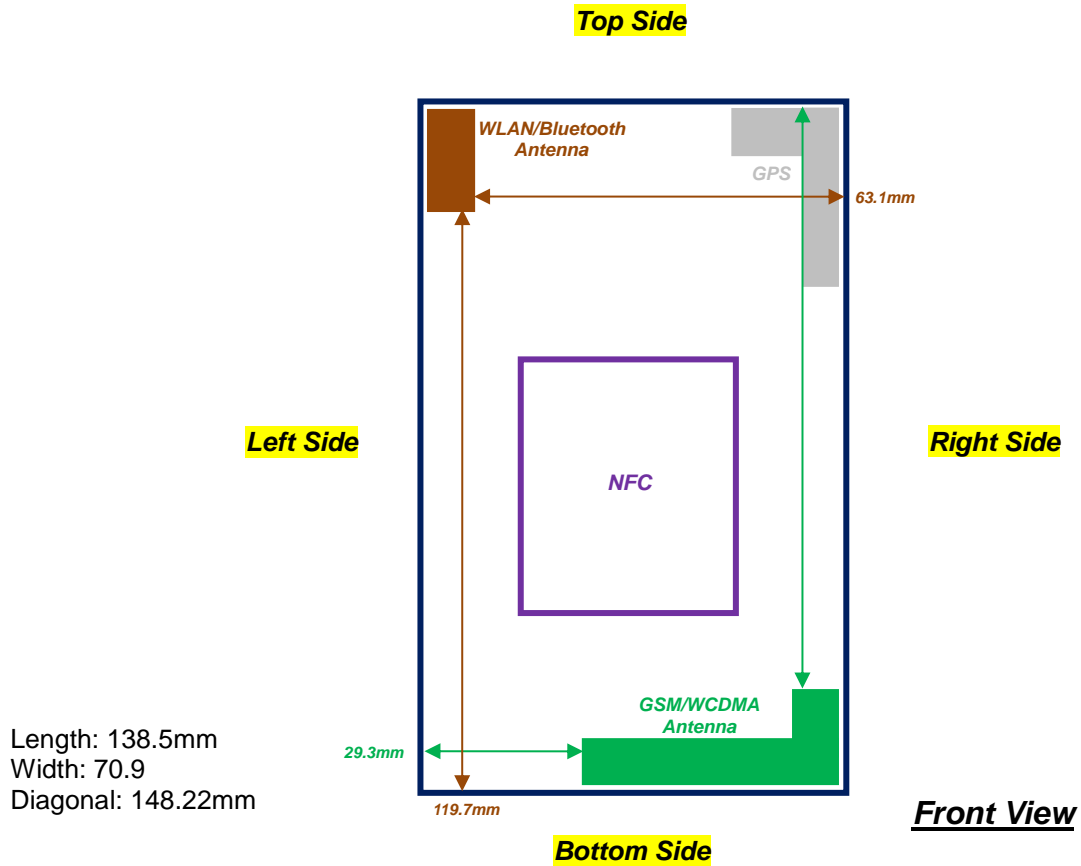

Distance of the Antenna to the EUT surface/edge						
Antennas	Back	Front	Top Side	Bottom Side	Right Side	Left Side
WWAN Main	≤ 25mm	≤ 25mm	78.3mm	≤ 25mm	≤ 25mm	29.3mm
BT&WLAN	≤ 25mm	≤ 25mm	≤ 25mm	119.7mm	63.1mm	≤ 25mm

Positions for SAR tests; Hotspot mode						
Antennas	Back	Front	Top Side	Bottom Side	Right Side	Left Side
WWAN Main	Yes	Yes	NO	Yes	Yes	NO
BT&WLAN	Yes	Yes	Yes	NO	NO	Yes

Note:

- Per KDB 941225 D06 v01, when the overall device length and width are $\geq 9\text{cm} \times 5\text{cm}$, the test distance is 10 mm. SAR must be measured for all sides and surfaces with a transmitting antenna located within 25mm from that surface or edge

12. SAR Test Results

Note:

1. Per KDB 447498 D01v05r01, the reported SAR is the measured SAR value adjusted for maximum tune-up tolerance.
 - a) Tune-up scaling Factor = tune-up limit power (mW) / EUT RF power (mW), where tune-up limit is the maximum rated power among all production units.
 - b) For SAR testing of WLAN signal with non-100% duty cycle, the measured SAR is scaled-up by the duty cycle scaling factor which is equal to "1/(duty cycle)"
 - c) For WWAN: Reported SAR(W/kg)= Measured SAR(W/kg)* Scaling Factor
 - d) For WLAN: Reported SAR(W/kg)= Measured SAR(W/kg)* Duty Cycle scaling factor * Tune-up scaling factor
2. Per KDB 447498 D01v05r01, for each exposure position, testing of other required channels within the operating mode of a frequency band is not required when the *reported* 1-g or 10-g SAR for the mid-band or highest output power channel is:
 - ≤ 0.8 W/kg or 2.0 W/kg, for 1-g or 10-g respectively, when the transmission band is ≤ 100 MHz
 - ≤ 0.6 W/kg or 1.5 W/kg, for 1-g or 10-g respectively, when the transmission band is between 100 MHz and 200 MHz
 - ≤ 0.4 W/kg or 1.0 W/kg, for 1-g or 10-g respectively, when the transmission band is ≥ 200 MHz
3. Per KDB 941225 D02v02r02, RMC 12.2kbps setting is used to evaluate SAR. If HSDPA/DC-HSDPA/HSUPA output power is < 0.25dB higher than RMC12.2kbps, or reported SAR with RMC 12.2kbps setting is ≤ 1.2W/kg, HSDPA/DC-HSDPA /HSUPA SAR evaluation can be excluded.
4. Per KDB 648474 D04v01, when the *reported* SAR for a body-worn accessory measured without a headset connected to the handset is ≤ 1.2 W/kg, SAR testing with a headset connected to the handset is not required.
5. In 5180MHz-5240MHz, 5745MHz-5805MHz, the device supports WiFi direct group client only and will not provide infrastructure access (AP) to other devices, and therefore hotspot SAR testing was not performed.
6. The device does not have limitation to operate VOIP in EGPRS wireless interface; considering the data rate of EGPRS to support VOIP quality and realistic operation, SAR testing was not performed evaluation VOIP operation in EGPRS mode.

12.1 Test Records for Head SAR Test

<GSM SAR>

Plot No.	Band	Mode	Test Position	Ch.	Freq. (MHz)	Average Power (dBm)	Tune-Up Limit (dBm)	Tune-up Scaling Factor	Power Drift (dB)	Measured SAR 1g (W/kg)	Scaled SAR 1g (W/kg)
37	GSM850	DTM Multi-slot class 5	Right Cheek	251	848.8	30.96	31.7	1.186	-0.02	0.399	0.473
38	GSM850	DTM Multi-slot class 5	Right Tilted	251	848.8	30.96	31.7	1.186	-0.02	0.206	0.244
39	GSM850	DTM Multi-slot class 5	Left Cheek	251	848.8	30.96	31.7	1.186	-0.02	0.304	0.360
40	GSM850	DTM Multi-slot class 5	Left Tilted	251	848.8	30.96	31.7	1.186	-0.06	0.184	0.218
29	GSM1900	DTM Multi-slot class 5	Right Cheek	512	1850.2	29.4	29.7	1.072	0.03	0.132	0.141
30	GSM1900	DTM Multi-slot class 5	Right Tilted	512	1850.2	29.4	29.7	1.072	0.01	0.048	0.051
31	GSM1900	DTM Multi-slot class 5	Left Cheek	512	1850.2	29.4	29.7	1.072	0.02	0.103	0.110
32	GSM1900	DTM Multi-slot class 5	Left Tilted	512	1850.2	29.4	29.7	1.072	0.1	0.071	0.076

<WCDMA SAR>

Plot No.	Band	Mode	Test Position	Ch.	Freq. (MHz)	Average Power (dBm)	Tune-Up Limit (dBm)	Tune-up Scaling Factor	Power Drift (dB)	Measured SAR 1g (W/kg)	Scaled SAR 1g (W/kg)
41	WCDMA V	RMC 12.2Kbps	Right Cheek	4132	826.4	23.5	23.7	1.047	-0.161	0.161	0.169
42	WCDMA V	RMC 12.2Kbps	Right Tilted	4132	826.4	23.5	23.7	1.047	-0.111	0.093	0.097
43	WCDMA V	RMC 12.2Kbps	Left Cheek	4132	826.4	23.5	23.7	1.047	0.016	0.128	0.134
44	WCDMA V	RMC 12.2Kbps	Left Tilted	4132	826.4	23.5	23.7	1.047	-0.072	0.084	0.088
33	WCDMA II	RMC 12.2Kbps	Right Cheek	9262	1852.4	23.3	23.7	1.096	0.03	0.135	0.148
34	WCDMA II	RMC 12.2Kbps	Right Tilted	9262	1852.4	23.3	23.7	1.096	0.19	0.054	0.059
35	WCDMA II	RMC 12.2Kbps	Left Cheek	9262	1852.4	23.3	23.7	1.096	0.05	0.117	0.128
36	WCDMA II	RMC 12.2Kbps	Left Tilted	9262	1852.4	23.3	23.7	1.096	0.07	0.074	0.081



<WLAN SAR DTS>

Plot No.	Band	Mode	Test Position	Ch.	Freq. (MHz)	Average Power (dBm)	Tune-Up Limit (dBm)	Tune-up Scaling Factor	Duty Cycle %	Duty Cycle scaling Factor	Power Drift (dB)	Measured SAR 1g (W/kg)	Scaled SAR 1g (W/kg)
45	WLAN2.4GHZ	802.11b 1Mbps	Right Cheek	11	2462	15.91	17	1.285	99.11	1.009	0.058	0.386	0.500
46	WLAN2.4GHZ	802.11b 1Mbps	Right Tilted	11	2462	15.91	17	1.285	99.11	1.009	-0.002	0.349	0.452
47	WLAN2.4GHZ	802.11b 1Mbps	Left Cheek	11	2462	15.91	17	1.285	99.11	1.009	0.089	0.204	0.265
48	WLAN2.4GHZ	802.11b 1Mbps	Left Tilted	11	2462	15.91	17	1.285	99.11	1.009	0.005	0.200	0.260
91	WLAN5GHZ	802.11a 6Mbps	Right Cheek	149	5745	12.11	13.5	1.376	95.39	1.048	-0.16	0.00102	0.001
92	WLAN5GHZ	802.11a 6Mbps	Right Tilted	149	5745	12.11	13.5	1.376	95.39	1.048	-0.1	0.00263	0.004
93	WLAN5GHZ	802.11a 6Mbps	Left Cheek	149	5745	12.11	13.5	1.376	95.39	1.048	-0.04	0.108	0.155
94	WLAN5GHZ	802.11a 6Mbps	Left Tilted	149	5745	12.11	13.5	1.376	95.39	1.048	0	0.0044	0.007
95	WLAN5GHZ	802.11ac-VHT80 MCS0	Left Cheek	155	5775	10.57	11.5	1.239	82.27	1.216	-0.13	0.00688	0.010

<WLAN SAR NII>

Plot No.	Band	Mode	Test Position	Ch.	Freq. (MHz)	Average Power (dBm)	Tune-Up Limit (dBm)	Tune-up Scaling Factor	Duty Cycle %	Duty Cycle scaling Factor	Power Drift (dB)	Measured SAR 1g (W/kg)	Scaled SAR 1g (W/kg)
76	WLAN5GHZ	802.11a 6Mbps	Right Cheek	36	5180	13.31	13.5	1.044	95.39	1.048	0	0.000	0.000
77	WLAN5GHZ	802.11a 6Mbps	Right Tilted	36	5180	13.31	13.5	1.044	95.39	1.048	0.12	0.00227	0.002
78	WLAN5GHZ	802.11a 6Mbps	Left Cheek	36	5180	13.31	13.5	1.044	95.39	1.048	0.18	0.034	0.038
79	WLAN5GHZ	802.11a 6Mbps	Left Tilted	36	5180	13.31	13.5	1.044	95.39	1.048	0.16	0.037	0.041
80	WLAN5GHZ	802.11ac-VHT80 MCS0	Left Tilted	42	5210	11.02	11.5	1.117	82.27	1.216	0.14	0.000	0.000
81	WLAN5GHZ	802.11a 6Mbps	Right Cheek	52	5260	12.96	13.5	1.131	95.39	1.048	0.19	0.00348	0.005
82	WLAN5GHZ	802.11a 6Mbps	Right Tilted	52	5260	12.96	13.5	1.131	95.39	1.048	-0.11	0.000	0.000
83	WLAN5GHZ	802.11a 6Mbps	Left Cheek	52	5260	12.96	13.5	1.131	95.39	1.048	0	0.000	0.000
84	WLAN5GHZ	802.11a 6Mbps	Left Tilted	52	5260	12.96	13.5	1.131	95.39	1.048	0.16	0.00332	0.004
85	WLAN5GHZ	802.11ac-VHT80 MCS0	Right Cheek	58	5290	10.81	11.5	1.173	82.27	1.216	0	0.000	0.000
86	WLAN5GHZ	802.11a 6Mbps	Right Cheek	100	5500	12.69	13.5	1.204	95.39	1.048	-0.18	0.014	0.018
87	WLAN5GHZ	802.11a 6Mbps	Right Tilted	100	5500	12.69	13.5	1.204	95.39	1.048	0.17	0.011	0.014
88	WLAN5GHZ	802.11a 6Mbps	Left Cheek	100	5500	12.69	13.5	1.204	95.39	1.048	0.14	0.000382	0.001
89	WLAN5GHZ	802.11a 6Mbps	Left Tilted	100	5500	12.69	13.5	1.204	95.39	1.048	0	0.000101	0.001
90	WLAN5GHZ	802.11ac-VHT80 MCS0	Right Cheek	106	5530	10.87	11.5	1.157	82.27	1.216	0	0.000	0.000

12.2 Test Records for Hotspot SAR Test

Distance of the Antenna to the EUT surface/edge						
Antennas	Back	Front	Top Side	Bottom Side	Right Side	Left Side
WWAN Main	≤ 25mm	≤ 25mm	78.3mm	≤ 25mm	≤ 25mm	29.3mm
BT&WLAN	≤ 25mm	≤ 25mm	≤ 25mm	119.7mm	63.1mm	≤ 25mm

Positions for SAR tests; Hotspot mode						
Antennas	Back	Front	Top Side	Bottom Side	Right Side	Left Side
WWAN Main	Yes	Yes	NO	Yes	Yes	NO
BT&WLAN	Yes	Yes	Yes	NO	NO	Yes

Note:

- Per KDB 941225 D06 v01, when the overall device length and width are ≥ 9cm*5cm, the test distance is 10 mm. SAR must be measured for all sides and surfaces with a transmitting antenna located within 25mm from that surface or edge

<GSM SAR>

Plot No.	Band	Mode	Test Position	Gap (cm)	Ch.	Freq. (MHz)	Average Power (dBm)	Tune-Up Limit (dBm)	Tune-up Scaling Factor	Power Drift (dB)	Measured SAR 1g (W/kg)	Scaled SAR 1g (W/kg)
15	GSM850	GPRS (2 Tx slots)	Back	1cm	251	848.8	31.12	31.7	1.143	0.02	0.353	0.403
17	GSM850	GPRS (2 Tx slots)	Back	1cm	251	848.8	31.12	31.7	1.143	-0.02	0.596	0.681
20	GSM850	GPRS (2 Tx slots)	Right Side	1cm	251	848.8	31.12	31.7	1.143	0	0.398	0.455
22	GSM850	GPRS (2 Tx slots)	Top Side	1cm	251	848.8	31.12	31.7	1.143	0.1	0.014	0.016
21	GSM850	GPRS (2 Tx slots)	Bottom Side	1cm	251	848.8	31.12	31.7	1.143	-0.01	0.216	0.247
1	GSM1900	GPRS (2 Tx slots)	Front	1cm	512	1850.2	29.44	29.7	1.062	-0.07	0.255	0.271
2	GSM1900	GPRS (2 Tx slots)	Back	1cm	512	1850.2	29.44	29.7	1.062	-0.01	0.523	0.555
4	GSM1900	GPRS (2 Tx slots)	Right Side	1cm	512	1850.2	29.44	29.7	1.062	-0.02	0.118	0.125
8	GSM1900	GPRS (2 Tx slots)	Top Side	1cm	512	1850.2	29.44	29.7	1.062	0.03	0.019	0.020
5	GSM1900	GPRS (2 Tx slots)	Bottom Side	1cm	512	1850.2	29.44	29.7	1.062	-0.1	0.557	0.591

<WCDMA SAR>

Plot No.	Band	Mode	Test Position	Gap (cm)	Ch.	Freq. (MHz)	Average Power (dBm)	Tune-Up Limit (dBm)	Tune-up Scaling Factor	Power Drift (dB)	Measured SAR 1g (W/kg)	Scaled SAR 1g (W/kg)
24	WCDMA V	RMC 12.2Kbps	Front	1cm	4132	826.4	23.5	23.7	1.047	0.02	0.208	0.218
23	WCDMA V	RMC 12.2Kbps	Back	1cm	4132	826.4	23.5	23.7	1.047	0.01	0.362	0.379
26	WCDMA V	RMC 12.2Kbps	Right Side	1cm	4132	826.4	23.5	23.7	1.047	0.04	0.253	0.265
27	WCDMA V	RMC 12.2Kbps	Bottom Side	1cm	4132	826.4	23.5	23.7	1.047	-0.08	0.098	0.103
9	WCDMA II	RMC 12.2Kbps	Front	1cm	9262	1852.4	23.3	23.7	1.096	-0.07	0.243	0.266
10	WCDMA II	RMC 12.2Kbps	Back	1cm	9262	1852.4	23.3	23.7	1.096	0	0.492	0.539
12	WCDMA II	RMC 12.2Kbps	Right Side	1cm	9262	1852.4	23.3	23.7	1.096	0	0.109	0.120
14	WCDMA II	RMC 12.2Kbps	Bottom Side	1cm	9262	1852.4	23.3	23.7	1.096	-0.05	0.526	0.577

<WLAN SAR DTS>

Plot No.	Band	Mode	Test Position	Gap (cm)	Ch.	Freq. (MHz)	Average Power (dBm)	Tune-Up Limit (dBm)	Tune-up Scaling Factor	Duty Cycle %	Duty Cycle Scaling Factor	Power Drift (dB)	Measured SAR 1g (W/kg)	Scaled SAR 1g (W/kg)
49	WLAN2.4GHz	802.11b 1Mbps	Front	1cm	11	2462	15.91	17	1.285	99.11	1.009	-0.079	0.070	0.091
50	WLAN2.4GHz	802.11b 1Mbps	Back	1cm	11	2462	15.91	17	1.285	99.11	1.009	0.055	0.067	0.087
51	WLAN2.4GHz	802.11b 1Mbps	Left Side	1cm	11	2462	15.91	17	1.285	99.11	1.009	0.123	0.065	0.085
53	WLAN2.4GHz	802.11b 1Mbps	Top Side	1cm	11	2462	15.91	17	1.285	99.11	1.009	0.008	0.064	0.084

12.3 Test Records for Body Worn SAR Test

<GSM SAR>

Plot No.	Band	Mode	Test Position	Gap (cm)	Ch.	Freq. (MHz)	Average Power (dBm)	Tune-Up Limit (dBm)	Tune-up Scaling Factor	Power Drift (dB)	Measured SAR 1g (W/kg)	Scaled SAR 1g (W/kg)
16	GSM850	DTM Multi-slot class 5	Front	1cm	251	848.8	30.96	31.7	1.186	0.04	0.359	0.426
18	GSM850	DTM Multi-slot class 5	Back	1cm	251	848.8	30.96	31.7	1.186	-0.01	0.585	0.694
6	GSM1900	DTM Multi-slot class 5	Front	1cm	512	1850.2	29.4	29.7	1.072	-0.01	0.251	0.269
7	GSM1900	DTM Multi-slot class 5	Back	1cm	512	1850.2	29.4	29.7	1.072	-0.03	0.515	0.552

<WCDMA SAR>

Plot No.	Band	Mode	Test Position	Gap (cm)	Ch.	Freq. (MHz)	Average Power (dBm)	Tune-Up Limit (dBm)	Tune-up Scaling Factor	Power Drift (dB)	Measured SAR 1g (W/kg)	Scaled SAR 1g (W/kg)
24	WCDMA V	RMC 12.2Kbps	Front	1cm	4132	826.4	23.5	23.7	1.047	0.02	0.208	0.218
23	WCDMA V	RMC 12.2Kbps	Back	1cm	4132	826.4	23.5	23.7	1.047	0.01	0.362	0.379
9	WCDMA II	RMC 12.2Kbps	Front	1cm	9262	1852.4	23.3	23.7	1.096	-0.07	0.243	0.266
10	WCDMA II	RMC 12.2Kbps	Back	1cm	9262	1852.4	23.3	23.7	1.096	0	0.492	0.539

<WLAN SAR DTS>

Plot No.	Band	Mode	Test Position	Gap (cm)	Ch.	Freq. (MHz)	Average Power (dBm)	Tune-Up Limit (dBm)	Tune-up Scaling Factor	Duty Cycle %	Duty Cycle scaling Factor	Power Drift (dB)	Measured SAR 1g (W/kg)	Scaled SAR 1g (W/kg)
49	WLAN2.4GHz	802.11b 1Mbps	Front	1cm	11	2462	15.91	17	1.285	99.11	1.009	-0.079	0.070	0.091
50	WLAN2.4GHz	802.11b 1Mbps	Back	1cm	11	2462	15.91	17	1.285	99.11	1.009	0.055	0.067	0.087
68	WLAN5GHz	802.11a 6Mbps	Front	1cm	149	5745	12.11	13.5	1.376	95.39	1.048	0	0.000	0.000
69	WLAN5GHz	802.11a 6Mbps	Back	1cm	149	5745	12.11	13.5	1.376	95.39	1.048	-0.03	0.041	0.059
74	WLAN5GHz	802.11ac-VHT80 MCS0	Back	1cm	155	5775	10.57	11.5	1.239	82.27	1.216	-0.04	0.000	0.000

<WLAN SAR NII>

Plot No.	Band	Mode	Test Position	Gap (cm)	Ch.	Freq. (MHz)	Average Power (dBm)	Tune-Up Limit (dBm)	Tune-up Scaling Factor	Duty Cycle %	Duty Cycle Scaling Factor	Power Drift (dB)	Measured SAR 1g (W/kg)	Scaled SAR 1g (W/kg)
55	WLAN5GHz	802.11a 6Mbps	Front	1cm	36	5180	13.31	13.5	1.044	95.39	1.048	0.04	0.0069	0.007
56	WLAN5GHz	802.11a 6Mbps	Back	1cm	36	5180	13.31	13.5	1.044	95.39	1.048	-0.03	0.035	0.039
61	WLAN5GHz	802.11ac-VHT80 MCS0	Back	1cm	42	5210	11.02	11.5	1.117	82.27	1.216	-0.16	0.013	0.018
62	WLAN5GHz	802.11a 6Mbps	Front	1cm	52	5260	12.96	13.5	1.131	95.39	1.048	0.19	0.00491	0.006
63	WLAN5GHz	802.11a 6Mbps	Back	1cm	52	5260	12.96	13.5	1.131	95.39	1.048	0.02	0.023	0.027
64	WLAN5GHz	802.11ac-VHT80 MCS0	Back	1cm	58	5290	10.81	11.5	1.173	82.27	1.216	-0.02	0.00874	0.013
65	WLAN5GHz	802.11a 6Mbps	Front	1cm	100	5500	12.69	13.5	1.204	95.39	1.048	0.17	0.000731	0.001
66	WLAN5GHz	802.11a 6Mbps	Back	1cm	100	5500	12.69	13.5	1.204	95.39	1.048	0.06	0.014	0.018
67	WLAN5GHz	802.11ac-VHT80 MCS0	Back	1cm	106	5530	10.87	11.5	1.157	82.27	1.216	-0.08	0.00381	0.006

12.4 Highest SAR Plot

Test Laboratory: Sporton International Inc. SAR/HAC Testing Lab

Date: 2013/7/1

#18_GSM850_DTM Multi-slot class 5_Back_1cm_Ch251

DUT: 362142

Communication System: GSM850; Frequency: 848.8 MHz; Duty Cycle: 1:4
 Medium: MSL_850_130701 Medium parameters used: $f = 849$ MHz; $\sigma = 0.976$ mho/m; $\epsilon_r = 54.397$; $\rho = 1000$ kg/m³
 Ambient Temperature : 22.6 °C; Liquid Temperature : 21.6 °C

DASY5 Configuration:

- Probe: EX3DV4 - SN3792; ConvF(9.15, 9.15, 9.15); Calibrated: 2013/6/4;
- Sensor-Surface: 2mm (Mechanical Surface Detection)
- Electronics: DAE4 Sn1338; Calibrated: 2013/5/28
- Phantom: SAM Left; Type: QD000P40CD; Serial: TP:1542
- Measurement SW: DASY52, Version 52.8 (3);SEMCAD X Version 14.6.5 (6469)

Configuration/Ch251/Area Scan (61x111x1): Measurement grid: dx=15mm, dy=15mm
 Maximum value of SAR (interpolated) = 0.671 mW/g

Configuration/Ch251/Zoom Scan (5x5x7)/Cube 0: Measurement grid: dx=8mm, dy=8mm, dz=5mm
 Reference Value = 26.629 V/m; Power Drift = -0.01 dB
 Peak SAR (extrapolated) = 0.739 mW/g
SAR(1 g) = 0.585 mW/g; SAR(10 g) = 0.450 mW/g
 Maximum value of SAR (measured) = 0.672 mW/g

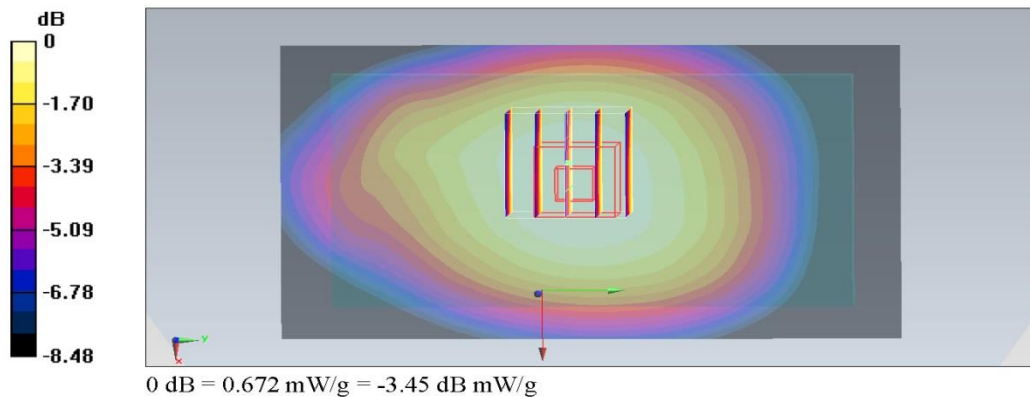

Test Laboratory: Sporton International Inc. SAR/HAC Testing Lab

Date: 2013/6/30

#05_GSM1900_GPRS (2 Tx slots)_Bottom Side_1cm_Ch512

DUT: 362142

Communication System: PCS; Frequency: 1850.2 MHz; Duty Cycle: 1:4
 Medium: MSL_1900_130630 Medium parameters used : f= 1850.2 MHz; $\sigma = 1.494$ mho/m; $\epsilon_r = 52.362$;
 $\rho = 1000$ kg/m³
 Ambient Temperature : 22.5 °C; Liquid Temperature : 21.5 °C

DASY5 Configuration:

- Probe: EX3DV4 - SN3792; ConvF(7.26, 7.26, 7.26); Calibrated: 2013/6/4;
- Sensor-Surface: 2mm (Mechanical Surface Detection)
- Electronics: DAE4 Sn1338; Calibrated: 2013/5/28
- Phantom: SAM Right; Type: QD000P40CC; Serial: TP:1383
- Measurement SW: DASY52, Version 52.8 (3); SEMCAD X Version 14.6.5 (6469)

Configuration/Ch512/Area Scan (41x61x1): Measurement grid: dx=15mm, dy=15mm
 Maximum value of SAR (interpolated) = 0.754 mW/g

Configuration/Ch512/Zoom Scan (5x5x7)/Cube 0: Measurement grid: dx=8mm, dy=8mm, dz=5mm
 Reference Value = 23.079 V/m; Power Drift = -0.10 dB
 Peak SAR (extrapolated) = 0.919 mW/g
SAR(1 g) = 0.557 mW/g; SAR(10 g) = 0.307 mW/g
 Maximum value of SAR (measured) = 0.752 mW/g

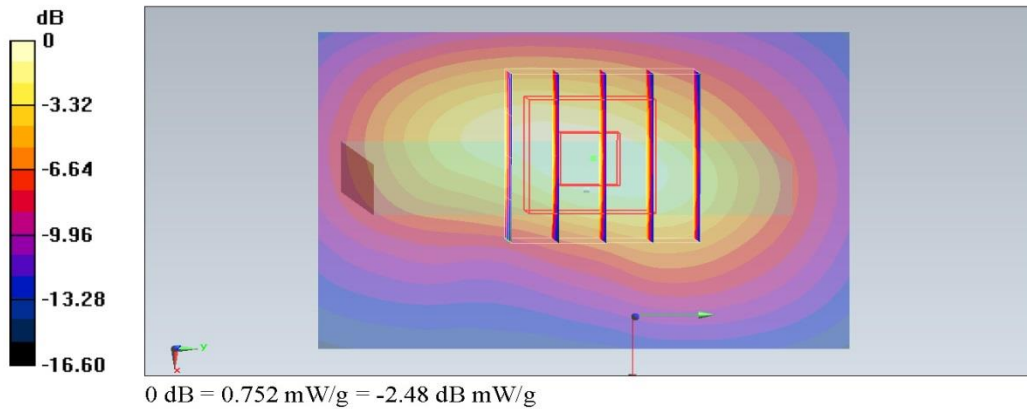

Test Laboratory: Sporton International Inc. SAR/HAC Testing Lab

Date: 2013/7/3

#45_WLAN2.4GHz_802.11b 1Mbps_Right Cheek_Ch11

DUT: 362142

Communication System: 802.11b ; Frequency: 2462 MHz;Duty Cycle: 1:1009

Medium: HSL_2450_130703 Medium parameters used: $f = 2462$ MHz; $\sigma = 1.86$ mho/m; $\epsilon_r = 39.2$; $\rho = 1000$ kg/m³

Ambient Temperature : 22.2 °C; Liquid Temperature : 21.2 °C

DASY4 Configuration:

- Probe: EX3DV4 - SN3697; ConvF(6.58, 6.58, 6.58); Calibrated: 2012/9/28
- Sensor-Surface: 2mm (Mechanical Surface Detection)
- Electronics: DAE4 Sn1279; Calibrated: 2013/1/28
- Phantom: SAM RIGHT; Type: SAM; Serial: 1719
- Measurement SW: DASY52, Version 52.8 (6); SEMCAD X Version 14.6.9 (7117)

Ch11/Area Scan (81x141x1): Measurement grid: dx=12mm, dy=12mm
Maximum value of SAR (interpolated) = 0.567 mW/g

Ch11/Zoom Scan (7x7x7)/Cube 0: Measurement grid: dx=5mm, dy=5mm, dz=5mm
Reference Value = 17.3 V/m; Power Drift = 0.058 dB
Peak SAR (extrapolated) = 0.771 W/kg
SAR(1 g) = 0.386 mW/g; SAR(10 g) = 0.190 mW/g
Maximum value of SAR (measured) = 0.557 mW/g

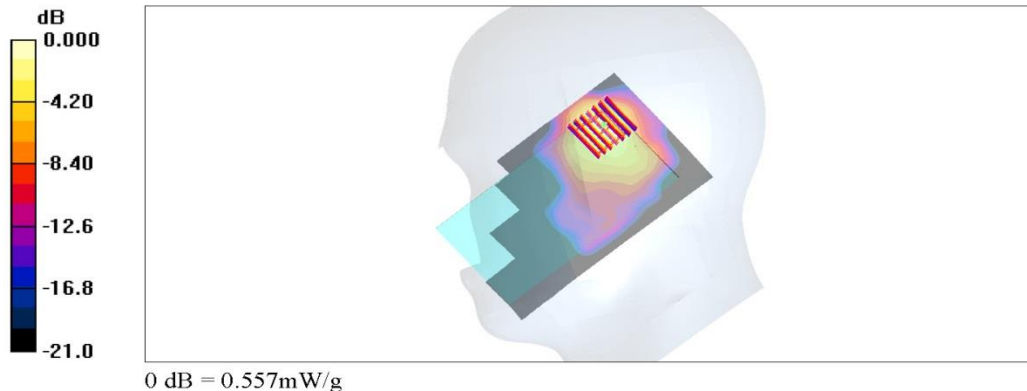

Test Laboratory: Sporton International Inc. SAR/HAC Testing Lab

Date: 2013/7/5

#93_WLAN5GHz_802.11a 6Mbps_Left Cheek_Ch149

DUT: 362142

Communication System: 802.11a; Frequency: 5745 MHz; Duty Cycle: 1:1.048
 Medium: HSL_5G_130705 Medium parameters used: $f = 5745 \text{ MHz}$; $\sigma = 5.074 \text{ S/m}$; $\epsilon_r = 36.792$; $\rho = 1000 \text{ kg/m}^3$
Ambient Temperature : 23.4 °C; Liquid Temperature : 22.4 °C

DASY5 Configuration:

- Probe: EX3DV4 - SN3697; ConvF(4.28, 4.28, 4.28); Calibrated: 2012/9/28;
- Sensor-Surface: 1.4mm (Mechanical Surface Detection)
- Electronics: DAE4 Sn1279; Calibrated: 2013/1/28
- Phantom: SAM RIGHT; Type: SAM; Serial: 1719
- Measurement SW: DASY52, Version 52.8 (6); SEMCAD X Version 14.6.9 (7117)

Configuration/Ch149/Area Scan (61x91x1): Interpolated grid: $dx=1.000 \text{ mm}$, $dy=1.000 \text{ mm}$
 Maximum value of SAR (interpolated) = 0.502 W/kg

Configuration/Ch149/Zoom Scan (7x7x7)/Cube 0: Measurement grid: $dx=4\text{mm}$, $dy=4\text{mm}$, $dz=1.4\text{mm}$

Reference Value = 8.606 V/m; Power Drift = -0.04 dB

Peak SAR (extrapolated) = 5.36 W/kg

SAR(1 g) = 0.108 W/kg; SAR(10 g) = 0.019 W/kg

Maximum value of SAR (measured) = 5.36 W/kg

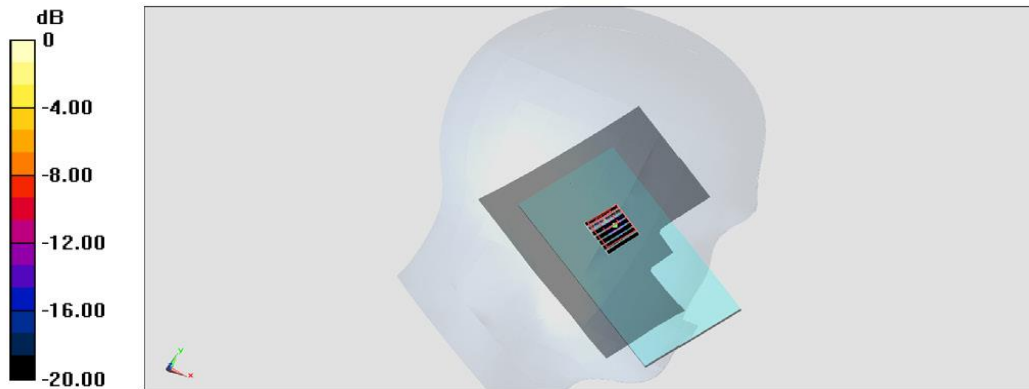

13. Simultaneous Transmission Analysis

NO.	Simultaneous Transmission Configurations	Portable Handset			Note
		Head	Body-worn	Hotspot	
1.	GSM(Voice) + WLAN2.4GHz(data)	Yes	Yes		
2.	WCDMA(Voice) + WLAN2.4GHz(data)	Yes	Yes		
3.	GSM(Voice) + Bluetooth(data)	Yes	Yes		
4.	WCDMA((Voice) + Bluetooth(data)	Yes	Yes		
5.	GSM(Voice) + WLAN5GHz(data)	Yes	Yes		
6.	WCDMA((Voice) + WLAN5GHz(data)	Yes	Yes		
7.	GPRS/EDGE(Data) + WLAN2.4GHz(data)	Yes ⁽¹⁾	Yes ⁽¹⁾	Yes	2.4GHz Hotspot
8.	WCDMA(Data) + WLAN2.4GHz(data)	Yes	Yes	Yes	2.4GHz Hotspot
9.	GPRS/EDGE(Data) + Bluetooth(data)	Yes ⁽¹⁾	Yes ⁽¹⁾	Yes	
10.	WCDMA(Data) + Bluetooth(data)	Yes	Yes	Yes	
11.	GPRS/EDGE(data) + WLAN5GHz(data)	Yes ⁽¹⁾	Yes ⁽¹⁾		WiFi Direct ⁽²⁾
12.	WCDMA(data) + WLAN5GHz(data)	Yes	Yes		WiFi Direct ⁽²⁾

Note:

- The device does not have limitation to operate VOIP in EGPRS wireless interface; considering the data rate of EGPRS to support VOIP quality and realistic operation, SAR testing was not performed evaluation VOIP operation in EGPRS mode.
- In 5180MHz-5240MHz, 5745MHz-5805MHz, the device supports WiFi direct group client only and will not provide infrastructure access (AP) to other devices, and therefore hotspot SAR testing was not performed.
- GSM and WCDMA cannot transmit simultaneously since they share the same chip.
- WLAN and Bluetooth share the same chip, and cannot transmit simultaneously.
- EUT will choose either WLAN 2.4GHz or WLAN 5GHz according to the network signal condition; therefore, they will not transmit simultaneously.
- The Scaled SAR summation is calculated based on the same configuration and test position.
- Per KDB 447498 D01v05r01, simultaneous transmission SAR is compliant if,
 - Scalar SAR summation < 1.6W/kg.
 - $SPLSR = (SAR_1 + SAR_2)^{1.5} / (min. \text{ separation distance, mm})$, and the peak separation distance is determined from the square root of $[(x_1-x_2)^2 + (y_1-y_2)^2 + (z_1-z_2)^2]$, where (x_1, y_1, z_1) and (x_2, y_2, z_2) are the coordinates of the extrapolated peak SAR locations in the zoom scan
If $SPLSR \leq 0.04$, simultaneously transmission SAR measurement is not necessary
 - Simultaneously transmission SAR measurement, and the reported multi-band SAR < 1.6W/kg
- For simultaneous transmission analysis, Bluetooth SAR is estimated per KDB 447498 D01v05r01 based on the formula below.
 - $(max. \text{ power of channel, including tune-up tolerance, mW}) / (min. \text{ test separation distance, mm}) \cdot [\sqrt{f(\text{GHz})} / x] \text{ W/kg}$ for test separation distances $\leq 50 \text{ mm}$; where $x = 7.5$ for 1-g SAR, and $x = 18.75$ for 10-g SAR.
 - 0.4 W/kg for 1-g SAR and 1.0 W/kg for 10-g SAR, when the test separation distances is > 50 mm.

Bluetooth Max Power	Exposure Position	Head	Hotspot	Body-worn
	Test separation	0 mm	10 mm	10 mm
9.0 dBm	Antenna to user distance	0 mm	10 mm	10 mm
	Estimated SAR (W/kg)	0.334 W/kg	0.167 W/kg	0.167 W/kg



13.1 Head Exposure Conditions

<WWAN + WLAN2.4GHz Band>

Position	WWAN			WLAN		Summed SAR (W/kg)
	WWAN Band	Plot No	SAR (W/kg)	Plot No	SAR (W/kg)	
Right Cheek	GSM850	37	0.473	45	0.500	0.97
	GSM1900	29	0.141	45	0.500	0.64
	WCDMA V	41	0.169	45	0.500	0.67
	WCDMA II	33	0.148	45	0.500	0.65
Right Tilted	GSM850	38	0.244	46	0.452	0.70
	GSM1900	30	0.051	46	0.452	0.50
	WCDMA V	42	0.097	46	0.452	0.55
	WCDMA II	34	0.059	46	0.452	0.51
Left Cheek	GSM850	39	0.360	47	0.265	0.63
	GSM1900	31	0.110	47	0.265	0.38
	WCDMA V	43	0.134	47	0.265	0.40
	WCDMA II	35	0.128	47	0.265	0.39
Left Tilted	GSM850	40	0.218	48	0.260	0.48
	GSM1900	32	0.076	48	0.260	0.34
	WCDMA V	44	0.088	48	0.260	0.35
	WCDMA II	36	0.081	48	0.260	0.34

<WWAN + WLAN5.2GHz Band>

Position	WWAN			WLAN		Summed SAR (W/kg)
	WWAN Band	Plot No	SAR (W/kg)	Plot No	SAR (W/kg)	
Right Cheek	GSM850	37	0.473	76	0.000	0.47
	GSM1900	29	0.141	76	0.000	0.14
	WCDMA V	41	0.169	76	0.000	0.17
	WCDMA II	33	0.148	76	0.000	0.15
Right Tilted	GSM850	38	0.244	77	0.002	0.25
	GSM1900	30	0.051	77	0.002	0.05
	WCDMA V	42	0.097	77	0.002	0.10
	WCDMA II	34	0.059	77	0.002	0.06
Left Cheek	GSM850	39	0.360	78	0.038	0.40
	GSM1900	31	0.110	78	0.038	0.15
	WCDMA V	43	0.134	78	0.038	0.17
	WCDMA II	35	0.128	78	0.038	0.17
Left Tilted	GSM850	40	0.218	79	0.041	0.26
	GSM1900	32	0.076	79	0.041	0.12
	WCDMA V	44	0.088	79	0.041	0.13
	WCDMA II	36	0.081	79	0.041	0.12



<WWAN + WLAN5.3GHz Band>

Position	WWAN			WLAN		Summed SAR (W/kg)
	WWAN Band	Plot No	SAR (W/kg)	Plot No	SAR (W/kg)	
Right Cheek	GSM850	37	0.473	81	0.005	0.48
	GSM1900	29	0.141	81	0.005	0.15
	WCDMA V	41	0.169	81	0.005	0.17
	WCDMA II	33	0.148	81	0.005	0.15
Right Tilted	GSM850	38	0.244	82	0.000	0.24
	GSM1900	30	0.051	82	0.000	0.05
	WCDMA V	42	0.097	82	0.000	0.10
	WCDMA II	34	0.059	82	0.000	0.06
Left Cheek	GSM850	39	0.360	83	0.000	0.36
	GSM1900	31	0.110	83	0.000	0.11
	WCDMA V	43	0.134	83	0.000	0.13
	WCDMA II	35	0.128	83	0.000	0.13
Left Tilted	GSM850	40	0.218	84	0.004	0.22
	GSM1900	32	0.076	84	0.004	0.08
	WCDMA V	44	0.088	84	0.004	0.09
	WCDMA II	36	0.081	84	0.004	0.09

<WWAN + WLAN5.5GHz Band>

Position	WWAN			WLAN		Summed SAR (W/kg)
	WWAN Band	Plot No	SAR (W/kg)	Plot No	SAR (W/kg)	
Right Cheek	GSM850	37	0.473	86	0.018	0.49
	GSM1900	29	0.141	86	0.018	0.16
	WCDMA V	41	0.169	86	0.018	0.19
	WCDMA II	33	0.148	86	0.018	0.17
Right Tilted	GSM850	38	0.244	87	0.014	0.26
	GSM1900	30	0.051	87	0.014	0.07
	WCDMA V	42	0.097	87	0.014	0.11
	WCDMA II	34	0.059	87	0.014	0.07
Left Cheek	GSM850	39	0.360	88	0.001	0.36
	GSM1900	31	0.110	88	0.001	0.11
	WCDMA V	43	0.134	88	0.001	0.14
	WCDMA II	35	0.128	88	0.001	0.13
Left Tilted	GSM850	40	0.218	89	0.001	0.22
	GSM1900	32	0.076	89	0.001	0.08
	WCDMA V	44	0.088	89	0.001	0.09
	WCDMA II	36	0.081	89	0.001	0.08



<WWAN + WLAN5.8GHz Band>

Position	WWAN			WLAN		Summed SAR (W/kg)
	WWAN Band	Plot No	SAR (W/kg)	Plot No	SAR (W/kg)	
Right Cheek	GSM850	37	0.473	91	0.001	0.47
	GSM1900	29	0.141	91	0.001	0.14
	WCDMA V	41	0.169	91	0.001	0.17
	WCDMA II	33	0.148	91	0.001	0.15
Right Tilted	GSM850	38	0.244	92	0.004	0.25
	GSM1900	30	0.051	92	0.004	0.06
	WCDMA V	42	0.097	92	0.004	0.10
	WCDMA II	34	0.059	92	0.004	0.06
Left Cheek	GSM850	39	0.36	93	0.155	0.52
	GSM1900	31	0.11	93	0.155	0.27
	WCDMA V	43	0.134	93	0.155	0.29
	WCDMA II	35	0.128	93	0.155	0.28
Left Tilted	GSM850	40	0.218	94	0.007	0.23
	GSM1900	32	0.076	94	0.007	0.08
	WCDMA V	44	0.088	94	0.007	0.10
	WCDMA II	36	0.081	94	0.007	0.09

<WWAN + Bluetooth>

Position	WWAN			Bluetooth	Summed SAR (W/kg)
	WWAN Band	Plot No	SAR (W/kg)	Estimated SAR (W/kg)	
Right Cheek	GSM850	37	0.473	0.334	0.81
	GSM1900	29	0.141	0.334	0.48
	WCDMA V	41	0.169	0.334	0.50
	WCDMA II	33	0.148	0.334	0.48
Right Tilted	GSM850	38	0.244	0.334	0.58
	GSM1900	30	0.051	0.334	0.39
	WCDMA V	42	0.097	0.334	0.43
	WCDMA II	34	0.059	0.334	0.39
Left Cheek	GSM850	39	0.360	0.334	0.69
	GSM1900	31	0.110	0.334	0.44
	WCDMA V	43	0.134	0.334	0.47
	WCDMA II	35	0.128	0.334	0.46
Left Tilted	GSM850	40	0.218	0.334	0.55
	GSM1900	32	0.076	0.334	0.41
	WCDMA V	44	0.088	0.334	0.42
	WCDMA II	36	0.081	0.334	0.42



13.2 Hotspot Exposure Conditions

<WWAN + WLAN2.4GHz Band>

Position	WWAN			WLAN		Summed SAR (W/kg)
	WWAN Band	Plot No	SAR (W/kg)	Plot No	SAR (W/kg)	
Front	GSM850	15	0.403	49	0.091	0.49
	GSM1900	1	0.271	49	0.091	0.36
	WCDMA V	24	0.218	49	0.091	0.31
	WCDMA II	9	0.266	49	0.091	0.36
Back	GSM850	17	0.681	50	0.087	0.77
	GSM1900	2	0.555	50	0.087	0.64
	WCDMA V	23	0.379	50	0.087	0.47
	WCDMA II	10	0.539	50	0.087	0.63
Left Side				51	0.085	0.37
				51	0.085	0.15
				51	0.085	0.26
				51	0.085	0.15
Right Side	GSM850	20	0.455			0.46
	GSM1900	4	0.125			0.13
	WCDMA V	26	0.265			0.27
	WCDMA II	12	0.120			0.12
Top Side				53	0.084	0.08
				53	0.084	0.08
				53	0.084	0.08
				53	0.084	0.08
Bottom Side	GSM850	21	0.247			0.25
	GSM1900	5	0.591			0.59
	WCDMA V	27	0.103			0.10
	WCDMA II	14	0.577			0.58

<WWAN + Bluetooth>

Position	WWAN			Bluetooth	Summed SAR (W/kg)
	WWAN Band	Plot No	SAR (W/kg)	Estimated SAR (W/kg)	
Front	GSM850	15	0.403	0.167	0.57
	GSM1900	1	0.271	0.167	0.44
	WCDMA V	24	0.218	0.167	0.39
	WCDMA II	9	0.266	0.167	0.43
Back	GSM850	17	0.681	0.167	0.85
	GSM1900	2	0.555	0.167	0.72
	WCDMA V	23	0.379	0.167	0.55
	WCDMA II	10	0.539	0.167	0.71
Left Side				0.167	0.45
				0.167	0.23
				0.167	0.35
				0.167	0.23
Right Side	GSM850	20	0.455		0.46
	GSM1900	4	0.125		0.13
	WCDMA V	26	0.265		0.27
	WCDMA II	12	0.120		0.12
Top Side				0.167	0.17
				0.167	0.17
				0.167	0.17
				0.167	0.17
Bottom Side	GSM850	21	0.247		0.25
	GSM1900	5	0.591		0.59
	WCDMA V	27	0.103		0.10
	WCDMA II	14	0.577		0.58

13.3 Body-Worn Exposure Conditions

<WWAN + WLAN2.4GHz Band>

Position	WWAN			WLAN		Summed SAR (W/kg)
	WWAN Band	Plot No	SAR (W/kg)	Plot No	SAR (W/kg)	
Front	GSM850	16	0.426	49	0.091	0.52
	GSM1900	6	0.269	49	0.091	0.36
	WCDMA V	24	0.218	49	0.091	0.31
	WCDMA II	9	0.266	49	0.091	0.36
Back	GSM850	18	0.694	50	0.087	0.78
	GSM1900	7	0.552	50	0.087	0.64
	WCDMA V	23	0.379	50	0.087	0.47
	WCDMA II	10	0.539	50	0.087	0.63

<WWAN + WLAN5.2GHz Band>

Position	WWAN			WLAN		Summed SAR (W/kg)
	WWAN Band	Plot No	SAR (W/kg)	Plot No	SAR (W/kg)	
Front	GSM850	16	0.426	55	0.007	0.43
	GSM1900	6	0.269	55	0.007	0.28
	WCDMA V	24	0.218	55	0.007	0.23
	WCDMA II	9	0.266	55	0.007	0.27
Back	GSM850	18	0.694	56	0.039	0.73
	GSM1900	7	0.552	56	0.039	0.59
	WCDMA V	23	0.379	56	0.039	0.42
	WCDMA II	10	0.539	56	0.039	0.58

<WWAN + WLAN5.3GHz Band>

Position	WWAN			WLAN		Summed SAR (W/kg)
	WWAN Band	Plot No	SAR (W/kg)	Plot No	SAR (W/kg)	
Front	GSM850	16	0.426	62	0.006	0.43
	GSM1900	6	0.269	62	0.006	0.28
	WCDMA V	24	0.218	62	0.006	0.22
	WCDMA II	9	0.266	62	0.006	0.27
Back	GSM850	18	0.694	63	0.027	0.72
	GSM1900	7	0.552	63	0.027	0.58
	WCDMA V	23	0.379	63	0.027	0.41
	WCDMA II	10	0.539	63	0.027	0.57



<WWAN + WLAN5.5GHz Band>

Position	WWAN			WLAN		Summed SAR (W/kg)
	WWAN Band	Plot No	SAR (W/kg)	Plot No	SAR (W/kg)	
Front	GSM850	16	0.426	65	0.001	0.43
	GSM1900	6	0.269	65	0.001	0.27
	WCDMA V	24	0.218	65	0.001	0.22
	WCDMA II	9	0.266	65	0.001	0.27
Back	GSM850	18	0.694	66	0.018	0.71
	GSM1900	7	0.552	66	0.018	0.57
	WCDMA V	23	0.379	66	0.018	0.40
	WCDMA II	10	0.539	66	0.018	0.56

<WWAN + WLAN5.8GHz Band>

Position	WWAN			WLAN		Summed SAR (W/kg)
	WWAN Band	Plot No	SAR (W/kg)	Plot No	SAR (W/kg)	
Front	GSM850	16	0.426	68	0.000	0.43
	GSM1900	6	0.269	68	0.000	0.27
	WCDMA V	24	0.218	68	0.000	0.22
	WCDMA II	9	0.266	68	0.000	0.27
Back	GSM850	18	0.694	69	0.059	0.75
	GSM1900	7	0.552	69	0.059	0.61
	WCDMA V	23	0.379	69	0.059	0.44
	WCDMA II	10	0.539	69	0.059	0.60

<WWAN + Bluetooth>

Position	WWAN			Bluetooth	Summed SAR (W/kg)
	WWAN Band	Plot No	SAR (W/kg)	Estimated SAR (W/kg)	
Front	GSM850	16	0.426	0.167	0.59
	GSM1900	6	0.269	0.167	0.44
	WCDMA V	24	0.218	0.167	0.39
	WCDMA II	9	0.266	0.167	0.43
Back	GSM850	18	0.694	0.167	0.86
	GSM1900	7	0.552	0.167	0.72
	WCDMA V	23	0.379	0.167	0.55
	WCDMA II	10	0.539	0.167	0.71

Test Engineer : Frank Wu, Angelo Chang, Mood Huang, Ted Sun, Vic Yang, Jack Wu, Nick Yu, Bevis Chang and Ken Li

14. Uncertainty Assessment

The component of uncertainty may generally be categorized according to the methods used to evaluate them. The evaluation of uncertainty by the statistical analysis of a series of observations is termed a Type A evaluation of uncertainty. The evaluation of uncertainty by means other than the statistical analysis of a series of observations is termed a Type B evaluation of uncertainty. Each component of uncertainty, however evaluated, is represented by an estimated standard deviation, termed standard uncertainty, which is determined by the positive square root of the estimated variance.

A Type A evaluation of standard uncertainty may be based on any valid statistical method for treating data. This includes calculating the standard deviation of the mean of a series of independent observations; using the method of least squares to fit a curve to the data in order to estimate the parameter of the curve and their standard deviations; or carrying out an analysis of variance in order to identify and quantify random effects in certain kinds of measurement.

A type B evaluation of standard uncertainty is typically based on scientific judgment using all of the relevant information available. These may include previous measurement data, experience, and knowledge of the behavior and properties of relevant materials and instruments, manufacture’s specification, data provided in calibration reports and uncertainties assigned to reference data taken from handbooks. Broadly speaking, the uncertainty is either obtained from an outdoor source or obtained from an assumed distribution, such as the normal distribution, rectangular or triangular distributions indicated in Table 14.1

Uncertainty Distributions	Normal	Rectangular	Triangular	U-Shape
Multi-plying Factor ^(a)	1/k ^(b)	1/√3	1/√6	1/√2

(a) standard uncertainty is determined as the product of the multiplying factor and the estimated range of variations in the measured quantity

(b) κ is the coverage factor

Table 14.1. Standard Uncertainty for Assumed Distribution

The combined standard uncertainty of the measurement result represents the estimated standard deviation of the result. It is obtained by combining the individual standard uncertainties of both Type A and Type B evaluation using the usual “root-sum-squares” (RSS) methods of combining standard deviations by taking the positive square root of the estimated variances.

Expanded uncertainty is a measure of uncertainty that defines an interval about the measurement result within which the measured value is confidently believed to lie. It is obtained by multiplying the combined standard uncertainty by a coverage factor. Typically, the coverage factor ranges from 2 to 3. Using a coverage factor allows the true value of a measured quantity to be specified with a defined probability within the specified uncertainty range. For purpose of this document, a coverage factor two is used, which corresponds to confidence interval of about 95 %. The DASY uncertainty Budget is shown in the following tables.



Error Description	Uncertainty Value (±%)	Probability Distribution	Divisor	Ci (1g)	Ci (10g)	Standard Uncertainty (1g)	Standard Uncertainty (10g)
Measurement System							
Probe Calibration	6.0	Normal	1	1	1	± 6.0 %	± 6.0 %
Axial Isotropy	4.7	Rectangular	√3	0.7	0.7	± 1.9 %	± 1.9 %
Hemispherical Isotropy	9.6	Rectangular	√3	0.7	0.7	± 3.9 %	± 3.9 %
Boundary Effects	1.0	Rectangular	√3	1	1	± 0.6 %	± 0.6 %
Linearity	4.7	Rectangular	√3	1	1	± 2.7 %	± 2.7 %
System Detection Limits	1.0	Rectangular	√3	1	1	± 0.6 %	± 0.6 %
Readout Electronics	0.3	Normal	1	1	1	± 0.3 %	± 0.3 %
Response Time	0.8	Rectangular	√3	1	1	± 0.5 %	± 0.5 %
Integration Time	2.6	Rectangular	√3	1	1	± 1.5 %	± 1.5 %
RF Ambient Noise	3.0	Rectangular	√3	1	1	± 1.7 %	± 1.7 %
RF Ambient Reflections	3.0	Rectangular	√3	1	1	± 1.7 %	± 1.7 %
Probe Positioner	0.4	Rectangular	√3	1	1	± 0.2 %	± 0.2 %
Probe Positioning	2.9	Rectangular	√3	1	1	± 1.7 %	± 1.7 %
Max. SAR Eval.	1.0	Rectangular	√3	1	1	± 0.6 %	± 0.6 %
Test Sample Related							
Device Positioning	2.9	Normal	1	1	1	± 2.9 %	± 2.9 %
Device Holder	3.6	Normal	1	1	1	± 3.6 %	± 3.6 %
Power Drift	5.0	Rectangular	√3	1	1	± 2.9 %	± 2.9 %
Phantom and Setup							
Phantom Uncertainty	4.0	Rectangular	√3	1	1	± 2.3 %	± 2.3 %
Liquid Conductivity (Target)	5.0	Rectangular	√3	0.64	0.43	± 1.8 %	± 1.2 %
Liquid Conductivity (Meas.)	2.5	Normal	1	0.64	0.43	± 1.6 %	± 1.1 %
Liquid Permittivity (Target)	5.0	Rectangular	√3	0.6	0.49	± 1.7 %	± 1.4 %
Liquid Permittivity (Meas.)	2.5	Normal	1	0.6	0.49	± 1.5 %	± 1.2 %
Combined Standard Uncertainty						± 11.0 %	± 10.8 %
Coverage Factor for 95 %						K=2	
Expanded Uncertainty						± 22.0 %	± 21.5 %

Table 14.2. Uncertainty Budget for frequency range 300 MHz to 3 GHz



Error Description	Uncertainty Value (±%)	Probability Distribution	Divisor	Ci (1g)	Ci (10g)	Standard Uncertainty (1g)	Standard Uncertainty (10g)
Measurement System							
Probe Calibration	6.55	Normal	1	1	1	± 6.55 %	± 6.55 %
Axial Isotropy	4.7	Rectangular	√3	0.7	0.7	± 1.9 %	± 1.9 %
Hemispherical Isotropy	9.6	Rectangular	√3	0.7	0.7	± 3.9 %	± 3.9 %
Boundary Effects	2.0	Rectangular	√3	1	1	± 1.2 %	± 1.2 %
Linearity	4.7	Rectangular	√3	1	1	± 2.7 %	± 2.7 %
System Detection Limits	1.0	Rectangular	√3	1	1	± 0.6 %	± 0.6 %
Readout Electronics	0.3	Normal	1	1	1	± 0.3 %	± 0.3 %
Response Time	0.8	Rectangular	√3	1	1	± 0.5 %	± 0.5 %
Integration Time	2.6	Rectangular	√3	1	1	± 1.5 %	± 1.5 %
RF Ambient Noise	3.0	Rectangular	√3	1	1	± 1.7 %	± 1.7 %
RF Ambient Reflections	3.0	Rectangular	√3	1	1	± 1.7 %	± 1.7 %
Probe Positioner	0.8	Rectangular	√3	1	1	± 0.5 %	± 0.5 %
Probe Positioning	9.9	Rectangular	√3	1	1	± 5.7 %	± 5.7 %
Max. SAR Eval.	4.0	Rectangular	√3	1	1	± 2.3 %	± 2.3 %
Test Sample Related							
Device Positioning	2.9	Normal	1	1	1	± 2.9 %	± 2.9 %
Device Holder	3.6	Normal	1	1	1	± 3.6 %	± 3.6 %
Power Drift	5.0	Rectangular	√3	1	1	± 2.9 %	± 2.9 %
Phantom and Setup							
Phantom Uncertainty	4.0	Rectangular	√3	1	1	± 2.3 %	± 2.3 %
Liquid Conductivity (Target)	5.0	Rectangular	√3	0.64	0.43	± 1.8 %	± 1.2 %
Liquid Conductivity (Meas.)	2.5	Normal	1	0.64	0.43	± 1.6 %	± 1.1 %
Liquid Permittivity (Target)	5.0	Rectangular	√3	0.6	0.49	± 1.7 %	± 1.4 %
Liquid Permittivity (Meas.)	2.5	Normal	1	0.6	0.49	± 1.5 %	± 1.2 %
Combined Standard Uncertainty						± 12.8 %	± 12.6 %
Coverage Factor for 95 %						K=2	
Expanded Uncertainty						± 25.6 %	± 25.2 %

Table 14.3. Uncertainty Budget for frequency range 3 GHz to 6 GHz



15. References

- [1] FCC 47 CFR Part 2 “Frequency Allocations and Radio Treaty Matters; General Rules and Regulations”
- [2] ANSI/IEEE Std. C95.1-1992, “IEEE Standard for Safety Levels with Respect to Human Exposure to Radio Frequency Electromagnetic Fields, 3 kHz to 300 GHz”, September 1992
- [3] IEEE Std. 1528-2003, “Recommended Practice for Determining the Peak Spatial-Average Specific Absorption Rate (SAR) in the Human Head from Wireless Communications Devices: Measurement Techniques”, December 2003
- [4] FCC OET Bulletin 65 (Edition 97-01) Supplement C (Edition 01-01), “Evaluating Compliance with FCC Guidelines for Human Exposure to Radiofrequency Electromagnetic Fields”, June 2001
- [5] SPEAG DASY System Handbook
- [6] FCC KDB 248227 D01 v01r02, “SAR Measurement Procedures for 802.11 a/b/g Transmitters”, May 2007
- [7] FCC KDB 447498 D01 v05r01, “Mobile and Portable Device RF Exposure Procedures and Equipment Authorization Policies”, May 2013
- [8] FCC KDB 648474 D04 v01r01, “SAR Evaluation Considerations for Wireless Handsets”, May 2013
- [9] FCC KDB 941225 D03 v01, “Recommended SAR Test Reduction Procedures for GSM / GPRS / EDGE”, December 2008
- [10] FCC KDB 941225 D04 v01, “Evaluating SAR for GSM/(E)GPRS Dual Transfer Mode”, January 2010
- [11] FCC KDB 941225 D01 v02, “SAR Measurement Procedures for 3G Devices – CDMA 2000 / Ev-Do / WCDMA / HSDPA / HSPA”, October 2007
- [12] FCC KDB 941225 D02 v02r02, “SAR Guidance for HSPA, HSPA+, DC-HSDPA and 1x-Advanced”, May 2013.
- [13] FCC KDB 941225 D06 v01r01, "SAR Evaluation Procedures for Portable Devices with Wireless Router Capabilities", May 2013
- [14] FCC KDB 644545 D01 v01r01, "Guidance for IEEE 802.11ac and Pre-ac Device Emission Testing", Apr 2013