

RF TEST REPORT

Test item : Multi Band GSM/WCDMA/LTE Phone with Bluetooth, WLAN and NFC
Model No. : LG-D722p, LGD722p, D722p, LG-D722P, LGD722P, D722P, LG-D722AR, LGD722AR, D722AR, LG-D722ar, LGD722ar, D722ar, LG-D722pa, D722pa, LGD722pa, LG-D722PA, D722PA, LGD722PA
Order No. : DEMC1408-03374
Date of receipt : 2014-08-11
Test duration : 2014-08-13 ~ 2014-08-29
Date of issue : 2014-09-24
Use of report : FCC Original Grant

Applicant : LG Electronics MobileComm U.S.A., Inc.
1000 Sylvan Avenue, Englewood Cliffs NJ 07632

Test laboratory : DT&C Co., Ltd.
42, Yurim-ro, 154beon-gil, Cheoin-gu, Yongin-si, Gyeonggi-do, Korea 449-935

Test specification : §22(H), §24(E)
Test environment : See appended test report
Test result : Pass Fail

The test results presented in this test report are limited only to the sample supplied by applicant and the use of this test report is inhibited other than its purpose. This test report shall not be reproduced except in full, without the written approval of DT&C Co., Ltd.

Tested by:



Engineer
JaeJin Lee

Reviewed by:



Technical Manager
Geunki Son

Test Report Version

Test Report No.	Date	Description
DRTFCC1409-1217	Sep. 24, 2014	Initial issue

Table of Contents

1. GENERAL INFORMATION	4
2. INTRODUCTION	5
2.1. EUT DESCRIPTION	5
2.2. MEASURING INSTRUMENT CALIBRATION.....	5
2.3. TEST FACILITY	5
3. DESCRIPTION OF TESTS.....	6
3.1 ERP & EIRP	6
3.2 PEAK TO AVERAGE RATIO.....	8
3.3 OCCUPIED BANDWIDTH.....	10
3.4 BAND EDGE EMISSIONS AT ANTENNA TERMINAL.....	11
3.5 SPURIOUS AND HARMONIC EMISSIONS AT ANTENNA TERMINAL.....	12
3.6 RADIATED SPURIOUS EMISSIONS	13
3.7 FREQUENCY STABILITY / VARIATION OF AMBIENT TEMPERATURE	14
4. LIST OF TEST EQUIPMENT.....	15
5. SUMMARY OF TEST RESULTS	16
6. SAMPLE CALCULATION	17
7. TEST DATA	18
7.1 PEAKTOAVERAGERATIO.....	18
7.2 OCCUPIED BANDWIDTH.....	18
7.3 SPURIOUS AND HARMONIC EMISSIONS AT ANTENNA TERMINAL	18
7.4 BAND EDGE	18
7.5 EFFECTIVE RADIATED POWER.....	19
7.6 EQUIVALENT ISOTROPIC RADIATED POWER	20
7.7 RADIATED SPURIOUS EMISSIONS	21
7.7.1 RADIATED SPURIOUS EMISSIONS (GSM850)	21
7.7.2 RADIATED SPURIOUS EMISSIONS (WCDMA850).....	22
7.7.3 RADIATED SPURIOUS EMISSIONS (HSUPA850)	23
7.7.4 RADIATED SPURIOUS EMISSIONS (GSM1900)	24
7.8.5 RADIATED SPURIOUS EMISSIONS (WCDMA1900).....	25
7.8.6 RADIATED SPURIOUS EMISSIONS (HSUPA1900)	26
7.8 FREQUENCY STABILITY / VARIATION OF AMBIENT TEMPERATURE	27
7.8.1 FREQUENCY STABILITY (GSM850)	27
7.8.2 FREQUENCY STABILITY (WCDMA850).....	28
7.8.3 FREQUENCY STABILITY (HSUPA850)	29
7.8.4 FREQUENCY STABILITY (GSM1900)	30
7.9.5 FREQUENCY STABILITY (WCDMA1900).....	31
7.9.4 FREQUENCY STABILITY (HSUPA1900)	32
8. TEST PLOTS	33
8.1 Peak to Average Ratio.....	33
8.2 Occupied Bandwidth(99 % Bandwidth)	36
8.3 Spurious Emissions at Antenna Terminal	52
8.4 Band Edge	67

1. GENERAL INFORMATION

Applicant Name: LG Electronics MobileComm U.S.A., Inc.

Address: 1000 Sylvan Avenue, Englewood Cliffs NJ 07632

- FCC ID** : ZNFD722P
- FCC Classification** : Licensed Portable Transmitter Held to Ear (PCE)
- EUT** : Multi Band GSM/WCDMA/LTE Phone with Bluetooth, WLAN and NFC
- Model Name** : LG-D722p
- Add Model Name** : LGD722p, D722p, LG-D722P, LGD722P, D722P, LG-D722AR, LGD722AR, D722AR, LG-D722ar, LGD722ar, D722ar, LG-D722pa, D722pa, LGD722pa, LG-D722PA, D722PA, LGD722PA
- Supplying power** : Standard Battery
 - Type: Li-ion Battery
 - M/N: BL-54SH
 - Rating: DC 3.8V & 2540mAh / 9.7Wh
- Antenna Information** : Internal Antenna
 - Type: Built-In type
- Tx Frequency** :
 - GSM850: 824.2 ~ 848.8 MHz
 - GSM1900: 1850.2 ~ 1909.8 MHz
 - EDGE850: 824.2 ~ 848.8 MHz
 - EDGE1900: 1850.2 ~ 1909.8 MHz
 - WCDMA850: 826.4 ~ 846.6 MHz
 - WCDMA1900: 1852.4 ~ 1907.6 MHz
 - HSUPA850: 826.4 ~ 846.6 MHz
 - HSUPA1900: 1852.4 ~ 1907.6 MHz
- Rx Frequency** :
 - GSM850: 869.2 ~ 893.8 MHz
 - GSM1900: 1930.2 ~ 1989.8 MHz
 - EDGE850: 869.2 ~ 893.8 MHz
 - EDGE1900: 1930.2 ~ 1989.8 MHz
 - WCDMA850: 871.4 ~ 891.6 MHz
 - WCDMA1900: 1932.4 ~ 1987.6 MHz
 - HSUPA850: 871.4 ~ 891.6 MHz
 - HSUPA1900: 1932.4 ~ 1987.6 MHz
- Max. RF Output Power** :
 - GSM850: 1.706 W ERP(32.32 dBm)
 - GSM1900: 1.294 W EIRP(31.12 dBm)
 - EDGE850: 0.451 W ERP(26.54 dBm)
 - EDGE1900: 0.425 W EIRP(26.28 dBm)
 - WCDMA850: 0.223 W ERP(23.48 dBm)
 - WCDMA1900: 0.366 W EIRP(25.64 dBm)
 - HSUPA850: 0.176 W ERP(22.46 dBm)
 - HSUPA1900: 0.290 W EIRP(24.63 dBm)
- Emission Designator(s)** :
 - GSM850: 245KGXW
 - GSM1900: 246KGXW
 - EDGE850: 245KG7W
 - EDGE1900: 245KG7W
 - WCDMA850: 4M15F9W
 - WCDMA1900: 4M16F9W
 - HSUPA850: 4M18F9W
 - HSUPA1900: 4M16F9W

2. INTRODUCTION

2.1. EUT DESCRIPTION

The Equipment Under Test (EUT) supports 850/1900 GSM/GPRS/EDGE, 850/1900 WCDMA/HSPA, Band 4 (1.4, 3, 5, 10, 15, 20 MHz BW), Band 2 (1.4, 3, 5, 10, 15, 20 MHz BW), Band 7 (5, 10, 15, 20 MHz BW) LTE, 802.11 b/g/n WLAN, Bluetooth (BDR, EDR, LE), NFC

2.2. MEASURING INSTRUMENT CALIBRATION

The measuring equipment, which was utilized in performing the tests documented herein, has been calibrated in accordance with the manufacturer's recommendations for utilizing calibration equipment, which is traceable to recognized national standards.

2.3. TEST FACILITY

The 3&10m test site and conducted measurement facility used to collect the radiated data are located at the 38, Yurim-ro, 154beon-gil, Cheoin-gu, Yongin-si, Gyeonggi-do, Korea 449-935. The site is constructed in conformance with the requirements.

- 3&10m test site registration Number: 678747

3. DESCRIPTION OF TESTS

3.1 ERP & EIRP

(Effective Radiated Power & Equivalent Isotropic Radiated Power)

Test Set-up

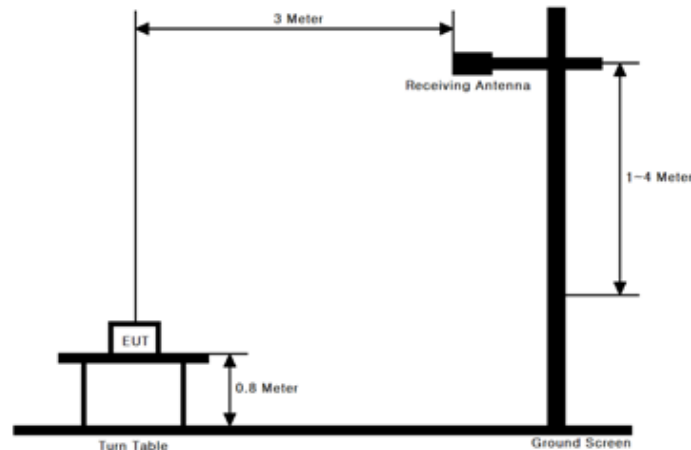

Test Procedure

- ANSI/TIA-603-C-2004 - Section 2.2.17
- KDB971168 v02r01 - Section 5.2.1

These measurements were performed at 3 & 10 m test site. The equipment under test is placed on a non-conductive table 0.8-meters above a turntable which is flush with the ground plane and 3 meters from the receive antenna.

Test setting

1. Set span to at least 1.5 times the OBW.
2. Set RBW = 1-5 % of the OBW, not to exceed 1 MHz.
3. Set VBW $\geq 3 \times$ RBW.
4. Set number of points in sweep $\geq 2 \times$ span / RBW.
5. Sweep time = auto couple.
6. Detector = RMS (power averaging).
7. If the EUT can be configured to transmit continuously (i.e., burst duty cycle ≥ 98 %), then set the trigger to free run.
8. If the EUT cannot be configured to transmit continuously (i.e., burst duty cycle < 98 %), then use a sweep trigger with the level set to enable triggering only on full power bursts and configure the EUT to transmit at full power for the entire duration of each sweep.
Ensure that the sweep time is less than or equal to the transmission burst duration.
9. Trace average at least 100 traces in power averaging (i.e., RMS) mode.
10. Compute the power by integrating the spectrum across the OBW of the signal using the instrument's band power measurement function, with the band limits set equal to the OBW band edges. If the instrument does not have a band power function, then sum the spectrum levels (in linear power units) at intervals equal to the RBW extending across the entire OBW of the spectrum.

The receive antenna height and turntable rotations were adjusted for the highest reading on the receive spectrum analyzer.

A half-wave dipole was substituted in place of the EUT. This dipole antenna was driven by a signal generator and the level of the signal generator was adjusted to obtain the same receive spectrum analyzer reading. The conducted power at the terminal of the substitute antenna is measured.

The ERP/EIRP is calculated using the following formula:

ERP/EIRP = The conducted power at the substitute antenna's terminal [dBm] + Substitute Antenna gain [dBd for ERP , dBi for EIRP]

For readings above 1 GHz, the above procedure is repeated using horn antennas and the difference between the gain of the horn antenna and an isotropic antenna are taken into consideration.

3.2 PEAK TO AVERAGE RATIO

Test set-up

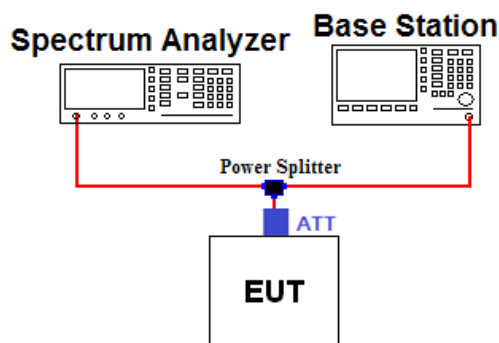

Test Procedure

A peak to average ratio measurement is performed using the following procedure.

■ CCDF Procedure

- KDB971168 v02r01-Section 5.7.1

1. Set resolution/measurement bandwidth \geq signal's occupied bandwidth
2. Set the number of counts to a value that stabilizes the measured CCDF curve
3. Set the measurement interval as follows:
 - 1) For continuous transmissions, set to 1 ms
 - 2) For burst transmissions, employ an external trigger that is synchronized with the EUT burst timing sequence, or use the internal burst trigger with a trigger level that allows the burst to stabilize and set the measurement interval to a time that is less than or equal to the burst duration.
4. Record the maximum PAPR level associated with a probability of 0.1%

■ Alternate Procedure**- KDB971168 v02r01-Section 5.7.2**

Use one of the measurement procedures of the peak power and record as P_{Pk} .

Use one of the measurement procedures of the average power and record as P_{Avg} .

Both the peak and average power levels must be expressed in the same logarithmic units (e.g., dBm). Determine the PAPR from:

$$\text{PAPR (dB)} = P_{Pk} \text{ (dBm)} - P_{Avg} \text{ (dBm)}.$$

- Peak Power Measurement

1. Set the RBW \geq OBW
2. Set VBW $\geq 3 \times$ RBW
3. Set span $\geq 2 \times$ RBW
4. Sweep time = auto couple
5. Detector = peak
6. Ensure that the number of measurement points \geq span/RBW.
7. Trace mode = max hold
8. Allow trace to fully stabilize.
9. Use the peak marker function to determine the peak amplitude level.

- Average Power Measurement

1. Set span to at least 1.5 times the OBW.
2. Set RBW = 1-5% of the OBW, not to exceed 1 MHz.
3. Set VBW $\geq 3 \times$ RBW.
4. Set number of points in sweep $\geq 2 \times$ span / RBW.
5. Sweep time = auto-couple.
6. Detector = RMS (power averaging).
7. If the EUT can be configured to transmit continuously (i.e., burst duty cycle $\geq 98\%$), then set the trigger to free run.
8. If the EUT cannot be configured to transmit continuously (i.e., burst duty cycle $< 98\%$), then use a sweep trigger with the level set to enable triggering only on full power bursts and configure the EUT to transmit at full power for the entire duration of each sweep. Ensure that the sweep time is less than or equal to the transmission burst duration.
9. Trace average at least 100 traces in power averaging (i.e., RMS) mode.
10. Compute the power by integrating the spectrum across the OBW of the signal using the instrument's band power measurement function, with the band limits set equal to the OBW band edges. If the instrument does not have a band power function, then sum the spectrum levels (in linear power units) at intervals equal to the RBW extending across the entire OBW of the spectrum.

3.3 OCCUPIED BANDWIDTH.

Test set-up

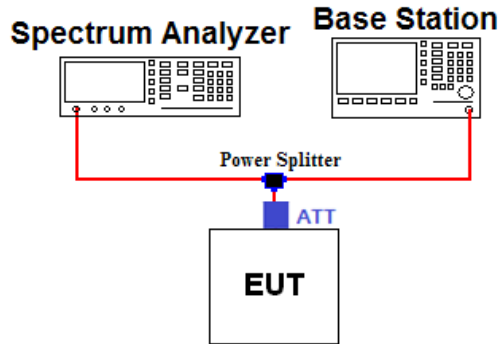

Offset value information

Frequency (MHz)	Offset Value (dB)	Frequency (MHz)	Offset Value (dB)
824.2	19.22	1850.2	19.77
826.4	19.21	1852.4	19.77
836.6	19.26	1880.0	19.84
846.6	19.28	1907.6	19.86
848.8	19.30	1909.8	19.86
-	-	-	-

Note. 1: The offset values from EUT to Spectrum analyzer were measured and used for test.
 Offset value = Cable A + Splitter + ATT + Cable B

Test Procedure

- KDB971168 v02r01-Section 4.2

The occupied bandwidth, that is the frequency bandwidth such that, below its lower and above its upper frequency limits, the mean powers radiated are each equal to 0.5 percent of the total mean power of a given emission.

Test setting

1. The signal analyzer's automatic bandwidth measurement capability was used to perform the 99 % occupied bandwidth and the 26 dB bandwidth. The bandwidth measurement was not influenced by any intermediate power nulls in the fundamental emission.
2. $RBW = 1 \sim 5 \%$ of the expected OBW & $VBW \geq 3 \times RBW$
3. Detector = Peak
4. Trance mode = Max hold
5. Sweep = Auto couple
6. The trace was allowed to stabilize
7. If necessary, step 2 ~ 6 were repeated after changing the RBW such that it would be within 1 ~ 5 % of the 99 % occupied bandwidth observed in step 6.

3.4 BAND EDGE EMISSIONS AT ANTENNA TERMINAL.

Test set-up

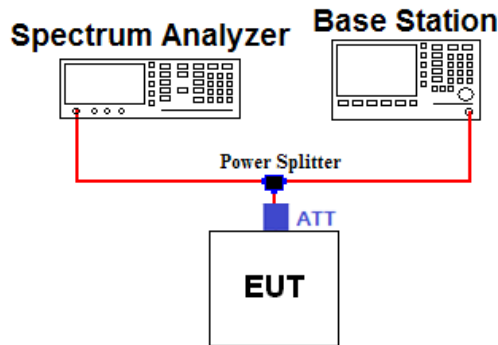

Offset value information

Frequency (MHz)	Offset Value (dB)	Frequency (MHz)	Offset Value (dB)
823.0	19.21	1849.0	19.76
824.0	19.22	1850.0	19.77
849.0	19.31	1910.0	19.87
850.0	19.31	1911.0	19.87
-	-	-	-

Note. 1: The offset value from EUT to Spectrum analyzer was measured and used for test.
 Offset value = Cable A + Splitter + ATT + Cable B

Test Procedure

- KDB971168 v02r01 - Section 6.0

All out of band emissions are measured by means of a calibrated spectrum analyzer. The EUT was setup to maximum output power at its lowest and highest channel with all modulations.

The power of any spurious emission shall be attenuated below the transmitter power (P) by at least $43 + 10 \log(P)$ dB

Test setting

1. Start and stop frequency were set such that the band edge would be placed in the center of the plot
2. Span was set large enough so as to capture all out of band emissions near the band edge
3. RBW $\geq 1\%$ of the emission
4. VBW $\geq 3 \times$ RBW
5. Detector = RMS & Trace mode = Max hold
6. Sweep time = Auto couple or 1 s for band edge
7. Number of sweep point $\geq 2 \times$ span / RBW
8. The trace was allowed to stabilize

Note 1: In the 1 MHz bands immediately outside and adjacent to the frequency block a resolution bandwidth of **at least one percent** of the emission bandwidth of the fundamental emission of the transmitter may be employed to demonstrate compliance with the out-of-band emissions limit. The emission bandwidth is defined as the width of the signal between two points, one below the carrier center frequency and one above the carrier center frequency, outside of which all emission are attenuated at least 26 dB below the transmitter power.

3.5 SPURIOUS AND HARMONIC EMISSIONS AT ANTENNA TERMINAL.

Test set-up

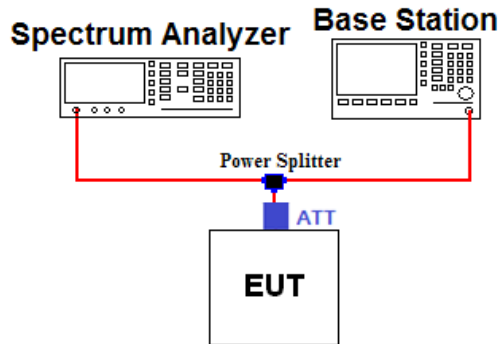

Offset value information

Frequency (MHz)	Offset Value (dB)	Frequency (MHz)	Offset Value (dB)
5000.0	21.44	15000.0	22.50
10000.0	22.09	20000.0	23.48
-	-	-	-

Note. 1: The offset value from EUT to Spectrum analyzer was measured and used for test.
 Offset value = Cable A + Splitter +ATT+ Cable B

Test Procedure

- KDB971168 v02r01 - Section 6.0

The level of the carrier and the various conducted spurious and harmonic frequencies is measured by means of a calibrated spectrum analyzer. The EUT was setup to maximum output power at its low, middle, high channel with all bandwidths. The spectrum is scanned from 30 MHz up to a frequency including its 10th harmonic.

The power of any spurious emission shall be attenuated below the transmitter power (P) by at least $43 + 10 \log(P)$ dB

Test setting

1. RBW = 100 KHz or 1 MHz & VBW $\geq 3 \times$ RBW (Refer to Note 1)
2. Detector = RMS & Trace mode = Max hold
3. Sweep time = Auto couple
4. Number of sweep point $\geq 2 \times$ span / RBW
5. The trace was allowed to stabilize

Note 1: Compliance with these provisions is based on the use of measurement instrumentation employing a resolution bandwidth of 100 kHz or greater for Part 22 and 1 MHz or greater for Part 24.

3.6 RADIATED SPURIOUS EMISSIONS

Test Set-up

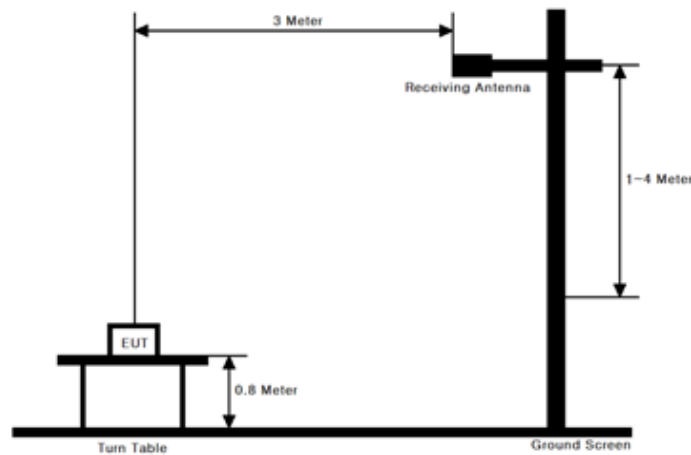

Test Procedure

- ANSI/TIA-603-C-2004 - Section 2.2.12
- KDB971168 v02r01 - Section 5.8

These measurements were performed at 3 & 10m test site. The equipment under test is placed on a non-conductive table 0.8-meters above a turntable which is flush with the ground plane and 3 meters from the receive antenna.

Test setting

1. RBW = 100 kHz for below 1 GHz and 1 MHz for above 1 GHz / VBW \geq 3 X RBW
2. Detector = Peak & Trace mode = Max hold
3. Sweep time = Auto couple
4. Number of sweep point \geq 2 X span / RBW
5. The trace was allowed to stabilize

The receive antenna height and turntable rotations were adjusted for the highest reading on the receive spectrum analyzer.

For radiated power measurements below 1 GHz, a half-wave dipole was substituted in place of the EUT. This dipole antenna was driven by a signal generator and the level of the signal generator was adjusted to obtain the same spectrum analyzer reading.

For radiated power measurements above 1 GHz, a Horn antenna was substituted in place of the EUT. This Horn antenna was driven by a signal generator and the level of the signal generator was adjusted to obtain the same spectrum analyzer reading. The difference between the gain of the horn and an isotropic antenna are taken into consideration.

This measurement was performed with the EUT oriented in 3 orthogonal axis.

3.7 FREQUENCY STABILITY / VARIATION OF AMBIENT TEMPERATURE

Test Set-up

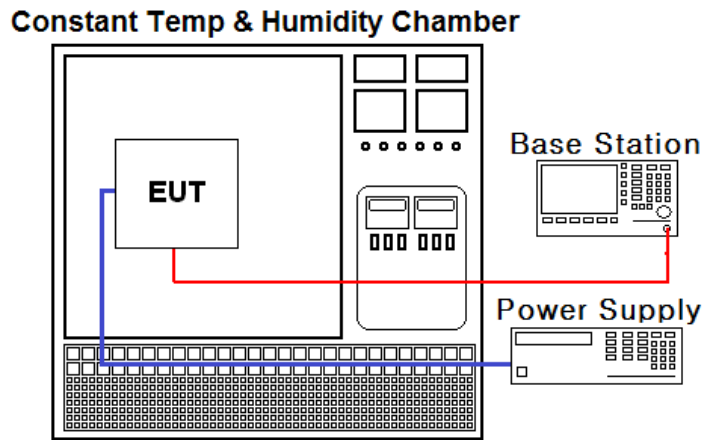

Test Procedure

- ANSI/TIA-603-C-2004
- KDB971168 v02r01 - Section 9.0

The frequency stability of the transmitter is measured by:

a.) Temperature:

The temperature is varied from - 30 °C to + 50 °C using an environmental chamber.

b.) Primary Supply Voltage:

The primary supply voltage is varied from 85 % to 115 % of the nominal value for non hand-carried battery and AC powered equipment. For hand-carried, battery-powered equipment, primary supply voltage is reduced to the battery operating end point which shall be specified by the manufacturer.

Specification:

The frequency stability shall be sufficient to ensure that the fundamental emission stays within the authorized frequency block for Part 24. The frequency stability of the transmitter shall be maintained within $\pm 0.00025\%$ (± 2.5 ppm) of the center frequency for Part 22.

Time Period and Procedure:

1. The carrier frequency of the transmitter is measured at room temperature.
(25 °C to provide a reference)
2. The equipment is turned on in a "standby" condition for one minute before applying power to the transmitter. Measurement of the carrier frequency of the transmitter is made within one minute after applying power to the transmitter.
3. Frequency measurements are made at 10 °C intervals ranging from -30 °C to +50 °C.
A period of at least one half-hour is provided to allow stabilization of the equipment at each temperature level.

4. LIST OF TEST EQUIPMENT

Type	Manufacturer	Model	Cal.Date (yy/mm/dd)	Next.Cal. Date (yy/mm/dd)	S/N
Spectrum Analyzer	Agilent	N9030A	13/10/29	14/10/29	MY53310140
Spectrum Analyzer	Agilent	N9020A	14/03/28	15/03/28	MY50510026
Multimeter	Fluke	17B	14/05/12	15/05/12	26030065WS
DC Power Supply	H.P	6633A	14/02/27	15/02/27	3524A06634
Temp & Humid Test Chamber	SJ Science	SJ-TH-S50	13/10/22	14/10/22	SJ-TH-S50-130930
Power Splitter	Anritsu	K241B	13/10/22	14/10/22	1701099
Attenuator(3dB)	SMAJK	SMAJK-2-3	13/10/22	14/10/22	3
Attenuator(10dB)	SMAJK	SMAJK-50-10	13/10/23	14/10/23	2-50-10
Thermo hygrometer	BODYCOM	BJ5478	14/03/03	15/03/03	1209
Dipole Antenna	Schwarzbeck	VHA9103	13/10/24	15/10/24	2116
Dipole Antenna	Schwarzbeck	VHA9103	14/04/01	16/04/01	2117
Dipole Antenna	Schwarzbeck	UHA9105	13/10/24	15/10/24	2261
Dipole Antenna	Schwarzbeck	UHA9105	14/04/01	16/04/01	2262
Bilog Antenna	SCHAFFNER	CBL6112B	12/11/06	14/11/06	2737
LOOP Antenna	Schwarzbeck	FMZB1513	14/04/29	16/04/29	1513-128
HORN ANT	ETS	3115	14/02/26	16/02/26	6419
HORN ANT	ETS	3117	14/05/12	16/05/12	00140394
HORN ANT	A.H.Systems	SAS-574	13/03/20	15/03/20	154
HORN ANT	A.H.Systems	SAS-574	13/05/27	15/05/27	155
Amplifier (22dB)	H.P	8447E	14/01/07	15/01/07	2945A02865
Amplifier (30dB)	Agilent	8449B	14/02/27	15/02/27	3008A00370
Amplifier	EMPOWER	BBS3Q7ELU	14/09/12	15/09/12	1020
High-pass filter	Wainwright	WHKX1.0	14/09/11	15/09/11	9
High-Pass Filter	Wainwright	WHNX2.1	14/09/11	15/09/11	1
8960 Series 10 Wireless Comms Test Set	Agilent	E5515C	14/02/28	15/02/28	GB43461134
Universal Radio Communication Tester	Rohde Schwarz	CMU200	14/02/28	15/02/28	106760
Vector Signal Generator	Rohde Schwarz	SMBV100A	14/01/08	15/01/08	255571
Signal Generator	Rohde Schwarz	SMF100A	14/07/01	15/07/01	102341

5. SUMMARY OF TEST RESULTS

FCC Part Section(s)	RSS Section(s)	Parameter	Status Note 1
2.1046	RSS-132 (5.4) RSS-133 (4.1)	Conducted Output Power	C ^{Note 2}
22.913(a) 24.232(c)	RSS-132 (5.4) [SRSP-503(5.1.3)] RSS-133 (6.4) [SRSP-510(5.1.2)]	Effective Radiated Power Equivalent Isotropic Radiated Power	C
22.917(a) 24.238(a) 2.1049	RSS-Gen (4.6.1)	Occupied Bandwidth	C
22.917(a) 24.238(a) 2.1051	RSS-132 (5.5) RSS-133 (6.5)	Band Edge Spurious and Harmonic Emissions at Antenna Terminal	C
24.232(d)	RSS-133 (6.4)	Peak to Average Ratio	C
22.917(a) 24.238(a) 2.1053	RSS-132 (5.5) RSS-133 (6.5)	Radiated Spurious and Harmonic Emissions	C
22.355 24.235 2.1055	RSS-132 (5.3) RSS-133 (6.3)	Frequency Stability	C

Note 1: **C**=Comply **NC**=Not Comply **NT**=Not Tested **NA**=Not Applicable
 Note 2: Refer to RF Exposure Report (Test Report_SAR)

The sample was tested according to the following specification:
ANSI/TIA/EIA-603-C-2004 and KDB 971168 D01 v02r01

6. SAMPLE CALCULATION

A. Emission Designator

GSM850 Emission Designator

Emission Designator = **245KGXW**
GSM OBW = 245.18 kHz
(Measured at the 99.75 % power bandwidth)
G = Phase Modulation
X = Cases not otherwise covered
W = Combination (Audio/Data)

EDGE850 Emission Designator

Emission Designator = **245KG7W**
GSM OBW = 244.66 kHz
(Measured at the 99.75 % power bandwidth)
G = Phase Modulation
7 = Two or more channels containing
quantized or digital information
W = Combination (Audio/Data)

WCDMA850 Emission Designator

Emission Designator = **4M15F9W**
WCDMA OBW = 4.1480 MHz
(Measured at the 99.75 % power bandwidth)
F = Frequency Modulation
9 = Composite Digital Information
W = Combination (Audio/Data)

WCDMA1900 Emission Designator

Emission Designator = **4M18F9W**
WCDMA OBW = 4.1815 MHz
(Measured at the 99.75 % power bandwidth)
F = Frequency Modulation
9 = Composite Digital Information
W = Combination (Audio/Data)

GSM1900 Emission Designator

Emission Designator = **246KGXW**
GSM OBW = 246.21 kHz
(Measured at the 99.75 % power bandwidth)
G = Phase Modulation
X = Cases not otherwise covered
W = Combination (Audio/Data)

EDGE1900 Emission Designator

Emission Designator = **245KG7W**
GSM OBW = 244.82 kHz
(Measured at the 99.75 % power bandwidth)
G = Phase Modulation
7 = Two or more channels containing
quantized or digital information
W = Combination (Audio/Data)

HSUPA850 Emission Designator

Emission Designator = **4M16F9W**
HSUPA OBW = 4.1559 MHz
(Measured at the 99.75 % power bandwidth)
F = Frequency Modulation
9 = Composite Digital Information
W = Combination (Audio/Data)

HSUPA1900 Emission Designator

Emission Designator = **4M16F9W**
HSUPA OBW = 4.1576 MHz
(Measured at the 99.75 % power bandwidth)
F = Frequency Modulation
9 = Composite Digital Information
W = Combination (Audio/Data)

7. TEST DATA

7.1 PEAK TO AVERAGE RATIO

- Plots of the EUT's Peak- to- Average Ratio are shown in Clause 8.1

7.2 OCCUPIED BANDWIDTH

Band	Channel	Frequency	Test Result (kHz)
GSM850	128	824.2	245.18
	190	836.6	245.10
	251	848.8	244.38
GSM1900	512	1850.2	246.21
	661	1880.0	244.44
	810	1909.8	245.43
EDGE850	128	824.2	242.24
	190	836.6	244.66
	251	848.8	242.00
EDGE1900	512	1850.2	244.46
	661	1880.0	244.82
	810	1909.8	244.02
WCDMA850	4132	826.4	4134.70
	4183	836.6	4141.80
	4233	846.6	4148.00
WCDMA1900	512	1850.2	4146.00
	661	1880.0	4155.90
	810	1909.8	4136.70
HSUPA850	4132	826.4	4155.80
	4183	836.6	4156.60
	4233	846.6	4181.50
HSUPA1900	9262	1852.4	4146.40
	9400	1880.0	4154.80
	9538	1907.6	4157.60

- Plots of the EUT's Occupied Bandwidth are shown in Clause 8.2

7.3 SPURIOUS AND HARMONIC EMISSIONS AT ANTENNA TERMINAL

- Plots of the EUT's Conducted Spurious Emissions are shown in Clause 8.3

7.4 BAND EDGE

- Plots of the EUT's Band Edge are shown in Clause 8.4

7.5 EFFECTIVE RADIATED POWER

- GSM850 data

CH.	EUT Position (Axis)	Test Conditions(Power Step: 5)						
		Pol. (H/V)	LEVEL@ TX ANTENNA TERMINAL (dBm)	Antenna Gain (dBd)	ERP (dBm)	ERP (W)	Rated Voltage	Note.
824.2 128	X	H	31.09	1.23	32.32	1.706	DC 3.8V	GSM
836.6 190	X	H	30.84	1.17	32.01	1.589	DC 3.8V	GSM
848.8 251	X	H	30.39	1.11	31.50	1.413	DC 3.8V	GSM
824.2 128	X	H	25.31	1.23	26.54	0.451	DC 3.8V	EDGE

- WCDMA850 data

CH.	EUT Position (Axis)	Test Conditions(TPC bits all set to "1")						
		Pol. (H/V)	LEVEL@ TX ANTENNA TERMINAL (dBm)	Antenna Gain (dBd)	ERP (dBm)	ERP (W)	Rated Voltage	Note.
826.4 4132	Z	H	22.26	1.22	23.48	0.223	DC 3.8V	-
836.6 4183	Z	H	22.06	1.17	23.23	0.210	DC 3.8V	-
846.6 4233	Z	H	21.28	1.12	22.40	0.174	DC 3.8V	-

- HSUPA850 data

CH.	EUT Position (Axis)	Test Conditions(TPC bits all set to "1")						
		Pol. (H/V)	LEVEL@ TX ANTENNA TERMINAL (dBm)	Antenna Gain (dBd)	ERP (dBm)	ERP (W)	Rated Voltage	Note.
826.4 4132	Z	H	21.08	1.22	22.30	0.170	DC 3.8V	-
836.6 4183	Z	H	21.29	1.17	22.46	0.176	DC 3.8V	-
846.6 4233	Z	H	19.84	1.12	20.96	0.125	DC 3.8V	-

NOTES:

This EUT was tested under all configurations and the highest power is reported in GSM mode and WCDMA mode with HSDPA inactive at 12.2 kbps RMC and TPC bits set to "1" and in GSM mode using a Power Control Level of "0" in PCS Band and "5" in the Cellular Band. This EUT was tested with the fully charged battery. Also, we have done x, y, z planes in EUT and horizontal and vertical polarization of detecting antenna. The worst case data is reported.

7.6 EQUIVALENT ISOTROPIC RADIATED POWER

- GSM1900 data

CH.	EUT Position (Axis)	TEST CONDITIONS(Power Step: 0)						
		Pol. (H/V)	LEVEL@ TX ANTENNA TERMINAL (dBm)	Antenna Gain (dBi)	EIRP (dBm)	EIRP (W)	Rated Voltage	Note.
1850.2 512	X	H	25.80	5.09	30.89	1.227	DC 3.8V	-
1880.0 661	X	H	25.65	5.06	30.71	1.178	DC 3.8V	-
1909.80 810	X	H	26.08	5.04	31.12	1.294	DC 3.8V	-
1909.80 810	X	H	21.24	5.04	26.28	0.425	DC 3.8V	-

- WCDMA1900 data

CH.	EUT Position (Axis)	Test Conditions(TPC bits all set to "1")						
		Pol. (H/V)	LEVEL@ TX ANTENNA TERMINAL (dBm)	Antenna Gain (dBi)	EIRP (dBm)	EIRP (W)	Rated Voltage	Note.
1852.4 9262	X	H	20.01	5.08	25.09	0.323	DC 3.8V	-
1880.0 9400	X	H	19.58	5.06	24.64	0.291	DC 3.8V	-
1907.6 9538	X	H	20.60	5.04	25.64	0.366	DC 3.8V	-

- HSUPA1900 data

CH.	EUT Position (Axis)	Test Conditions(TPC bits all set to "1")						
		Pol. (H/V)	LEVEL@ TX ANTENNA TERMINAL (dBm)	Antenna Gain (dBi)	EIRP (dBm)	EIRP (W)	Rated Voltage	Note.
1852.4 9262	X	H	18.73	5.08	23.81	0.240	DC 3.8V	-
1880.0 9400	X	H	18.47	5.06	23.53	0.225	DC 3.8V	-
1907.6 9538	X	H	19.59	5.04	24.63	0.290	DC 3.8V	-

NOTES:

This EUT was tested under all configurations and the highest power is reported in GSM mode and WCDMA mode with HSDPA inactive at 12.2 kbps RMC and TPC bits set to "1" and in GSM mode using a Power Control Level of "0" in PCS Band and "5" in the Cellular Band. This EUT was tested with the fully charged battery. Also, we have done x, y, z planes in EUT and horizontal and vertical polarization of detecting antenna. The worst case data is reported.

7.7 RADIATED SPURIOUS EMISSIONS

7.7.1 RADIATED SPURIOUS EMISSIONS (GSM850)

Channel (ERP)	Freq. (MHz)	EUT Position (Axis)	POL (H/V)	LEVEL@ ANTENNA TERMINAL (dBm)	Substitute Antenna Gain (dBd)	Correct Generator Level (dBm)	Result (dBc)	Limit (dBc)
128 (1.706 W)	1648.30	Z	V	-55.39	3.11	-52.28	84.60	45.32
	2472.72	Y	H	-52.01	3.27	-48.74	81.06	
	-	-	-	-	-	-	-	
190 (1.589 W)	1673.18	Z	V	-54.06	3.08	-50.98	82.99	45.01
	2510.04	Y	H	-52.97	3.34	-49.63	81.64	
	-	-	-	-	-	-	-	
251 (1.413 W)	1697.76	Z	V	-52.79	3.06	-49.73	81.23	44.50
	2546.62	Y	H	-53.60	3.48	-50.12	81.62	
	-	-	-	-	-	-	-	

- Limit Calculation= 43 + 10 log₁₀(ERP [W]) [dBc]

- No other spurious and harmonic emissions were reported greater than listed emissions above table.

NOTES:

This EUT was tested under all configurations and the highest power is reported in GSM mode and WCDMA mode with HSDPA inactive at 12.2 kbps RMC and TPC bits set to "1" and in GSM mode using a Power Control Level of "0" in PCS Band and "5" in the Cellular Band. This EUT was tested with the fully charged battery. Also, we have done x, y, z planes in EUT and horizontal and vertical polarization of detecting antenna.

The worst case data is reported.

7.7.2 RADIATED SPURIOUS EMISSIONS (WCDMA850)

Channel (ERP)	Freq. (MHz)	EUT Position (Axis)	POL (H/V)	LEVEL@ ANTENNA TERMINAL (dBm)	Substitute Antenna Gain (dBd)	Correct Generator Level (dBm)	Result (dBc)	Limit (dBc)
4132 (0.223 W)	1654.07	X	H	-60.68	3.10	-57.58	81.06	36.48
	2476.00	X	H	-59.24	3.28	-55.96	79.44	
	-	-	-	-	-	-	-	
4183 (0.210 W)	1671.83	X	H	-61.74	3.09	-58.65	81.88	36.23
	2513.44	X	H	-58.54	3.35	-55.19	78.42	
	-	-	-	-	-	-	-	
4233 (0.174 W)	1694.72	X	H	-59.57	3.07	-56.50	78.90	35.40
	2542.48	X	H	-60.91	3.46	-57.45	79.85	
	-	-	-	-	-	-	-	

- Limit Calculation= $43 + 10 \log_{10}(ERP [W])$ [dBc]

- No other spurious and harmonic emissions were reported greater than listed emissions above table.

NOTES:

This EUT was tested under all configurations and the highest power is reported in GSM mode and WCDMA mode with HSDPA inactive at 12.2 kbps RMC and TPC bits set to "1" and in GSM mode using a Power Control Level of "0" in PCS Band and "5" in the Cellular Band. This EUT was tested with the fully charged battery. Also, we have done x, y, z planes in EUT and horizontal and vertical polarization of detecting antenna.

The worst case data is reported.

7.7.3 RADIATED SPURIOUS EMISSIONS (HSUPA850)

Channel (ERP)	Freq. (MHz)	EUT Position (Axis)	POL (H/V)	LEVEL@ ANTENNA TERMINAL (dBm)	Substitute Antenna Gain (dBd)	Correct Generator Level (dBm)	Result (dBc)	Limit (dBc)
4132 (0.170 W)	1654.04	X	H	-62.49	3.10	-59.39	81.69	35.30
	2476.84	X	H	-60.33	3.28	-57.05	79.35	
	-	-	-	-	-	-	-	
4183 (0.176 W)	1674.93	X	H	-61.42	3.08	-58.34	80.80	35.46
	2511.82	X	H	-60.21	3.35	-56.86	79.32	
	-	-	-	-	-	-	-	
4233 (0.125 W)	1695.57	X	H	-60.03	3.07	-56.96	77.92	33.96
	2538.16	X	H	-60.15	3.45	-56.70	77.66	
	-	-	-	-	-	-	-	

- Limit Calculation= 43 + 10 log₁₀(ERP [W]) [dBc]

- No other spurious and harmonic emissions were reported greater than listed emissions above table.

NOTES:

This EUT was tested under all configurations and the highest power is reported in GSM mode and WCDMA mode with HSDPA inactive at 12.2 kbps RMC and TPC bits set to “1” and in GSM mode using a Power Control Level of “0” in PCS Band and “5” in the Cellular Band. This EUT was tested with the fully charged battery. Also, we have done x, y, z planes in EUT and horizontal and vertical polarization of detecting antenna.

The worst case data is reported.

7.7.4 RADIATED SPURIOUS EMISSIONS (GSM1900)

Channel (EIRP)	Freq. (MHz)	EUT Position (Axis)	POL (H/V)	LEVEL@ ANTENNA TERMINAL (dBm)	Substitute Antenna Gain (dBi)	Correct Generator Level (dBm)	Result (dBc)	Limit (dBc)
512 (1.227 W)	3700.55	Y	H	-55.40	8.40	-47.00	77.89	43.89
	5550.81	X	H	-47.45	10.11	-37.34	68.23	
	-	-	-	-	-	-	-	
661 (1.178 W)	3760.06	Y	H	-55.28	8.51	-46.77	77.48	43.71
	5640.27	X	H	-49.39	10.17	-39.22	69.93	
	-	-	-	-	-	-	-	
810 (1.294 W)	3819.65	Y	H	-54.14	8.62	-45.52	76.64	44.12
	5729.40	X	H	-48.85	10.23	-38.62	69.74	
	-	-	-	-	-	-	-	

- Limit Calculation = 43 + 10 log₁₀(EIRP [W]) [dBc]

- No other spurious and harmonic emissions were reported greater than listed emissions above table.

NOTES:

This EUT was tested under all configurations and the highest power is reported in GSM mode and WCDMA mode with HSDPA inactive at 12.2 kbps RMC and TPC bits set to “1” and in GSM mode using a Power Control Level of “0” in PCS Band and “5” in the Cellular Band. This EUT was tested with the fully charged battery. Also, we have done x, y, z planes in EUT and horizontal and vertical polarization of detecting antenna.

The worst case data is reported.

7.8.5 RADIATED SPURIOUS EMISSIONS (WCDMA1900)

Channel (EIRP)	Freq. (MHz)	EUT Position (Axis)	POL (H/V)	LEVEL@ ANTENNA TERMINAL (dBm)	Substitute Antenna Gain (dBi)	Correct Generator Level (dBm)	Result (dBc)	Limit (dBc)
9262 (0.323 W)	3706.41	X	H	-53.91	8.41	-45.50	70.59	38.09
	5554.86	X	V	-49.22	10.11	-39.11	64.20	
	-	-	-	-	-	-	-	
9400 (0.291 W)	3761.63	X	H	-51.26	8.52	-42.74	67.38	37.64
	5636.40	X	V	-45.69	10.17	-35.52	60.16	
	-	-	-	-	-	-	-	
9538 (0.366 W)	3816.96	X	H	-49.37	8.62	-40.75	66.39	38.64
	5726.20	X	V	-47.02	10.23	-36.79	62.43	
	-	-	-	-	-	-	-	

- Limit Calculation = 43 + 10 log₁₀(EIRP [W]) [dBc]

- No other spurious and harmonic emissions were reported greater than listed emissions above table.

NOTES:

This EUT was tested under all configurations and the highest power is reported in GSM mode and WCDMA mode with HSDPA inactive at 12.2 kbps RMC and TPC bits set to “1” and in GSM mode using a Power Control Level of “0” in PCS Band and “5” in the Cellular Band. This EUT was tested with the fully charged battery. Also, we have done x, y, z planes in EUT and horizontal and vertical polarization of detecting antenna. The worst case data is reported.

7.8.6 RADIATED SPURIOUS EMISSIONS (HSUPA1900)

Channel (EIRP)	Freq. (MHz)	EUT Position (Axis)	POL (H/V)	LEVEL@ ANTENNA TERMINAL (dBm)	Substitute Antenna Gain (dBi)	Correct Generator Level (dBm)	Result (dBc)	Limit (dBc)
9262 (0.240 W)	3707.37	X	H	-55.54	8.42	-47.12	70.93	36.81
	5559.78	X	V	-50.10	10.11	-39.99	63.80	
	-	-	-	-	-	-	-	
9400 (0.225 W)	3762.34	X	H	-53.23	8.52	-44.71	68.24	36.53
	5642.30	X	V	-47.98	10.17	-37.81	61.34	
	-	-	-	-	-	-	-	
9538 (0.290 W)	3816.61	X	H	-51.71	8.62	-43.09	67.72	37.63
	5725.08	X	V	-48.03	10.23	-37.80	62.43	
	-	-	-	-	-	-	-	

- Limit Calculation = $43 + 10 \log_{10}(\text{EIRP [W]})$ [dBc]

- No other spurious and harmonic emissions were reported greater than listed emissions above table.

NOTES:

This EUT was tested under all configurations and the highest power is reported in GSM mode and WCDMA mode with HSDPA inactive at 12.2 kbps RMC and TPC bits set to “1” and in GSM mode using a Power Control Level of “0” in PCS Band and “5” in the Cellular Band. This EUT was tested with the fully charged battery. Also, we have done x, y, z planes in EUT and horizontal and vertical polarization of detecting antenna. The worst case data is reported.

7.8 FREQUENCY STABILITY / VARIATION OF AMBIENT TEMPERATURE

7.8.1 FREQUENCY STABILITY (GSM850)

OPERATING FREQUENCY : 836,600,015 Hz
 CHANNEL : 190(Mid)
 REFERENCE VOLTAGE : 3.800V DC
 DEVIATION LIMIT : $\pm 0.00025\%$ or 2.5 ppm

VOLTAGE (%)	POWER (V DC)	TEMP (°C)	FREQ (Hz)	Deviation	
				(ppm)	(%)
100%	3.800	+25(Ref)	836,600,015	0.000	0.00000000
100%		-30	836,600,011	-0.005	-0.00000048
100%		-20	836,600,014	-0.001	-0.00000012
100%		-10	836,600,009	-0.007	-0.00000072
100%		0	836,600,016	0.001	0.00000012
100%		+10	836,600,008	-0.008	-0.00000084
100%		+20	836,600,013	-0.002	-0.00000024
100%		+30	836,600,012	-0.004	-0.00000036
100%		+40	836,600,014	-0.001	-0.00000012
100%		+50	836,600,010	-0.006	-0.00000060
115%	4.370	+25	836,600,013	-0.002	-0.00000024
BATT.ENDPOINT	3.400	+25	836,600,011	-0.005	-0.00000048

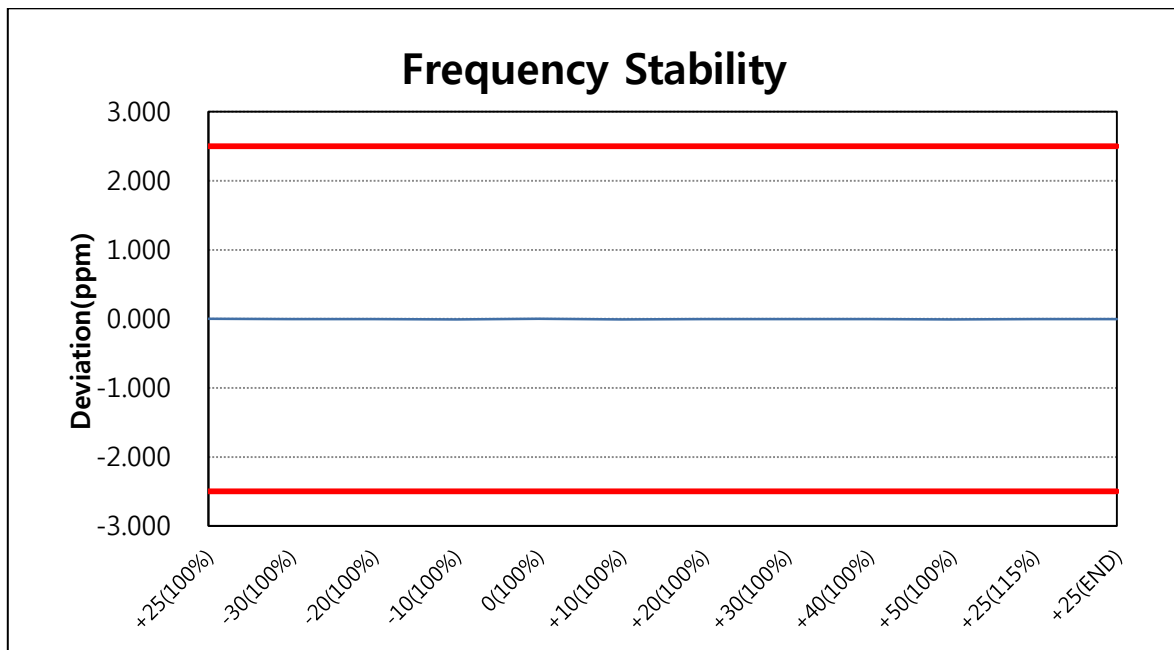

7.8.2 FREQUENCY STABILITY (WCDMA850)

OPERATING FREQUENCY : 836,599,999 Hz
 CHANNEL : 4183(Mid)
 REFERENCE VOLTAGE : 3.800 V DC
 DEVIATION LIMIT : $\pm 0.00025\%$ or 2.5 ppm

VOLTAGE (%)	POWER (V DC)	TEMP (°C)	FREQ (Hz)	Deviation	
				(ppm)	(%)
100%	3.800	+25(Ref)	836,599,999	0.000	0.00000000
100%		-30	836,599,996	-0.004	-0.00000036
100%		-20	836,599,997	-0.002	-0.00000024
100%		-10	836,599,996	-0.004	-0.00000036
100%		0	836,599,996	-0.004	-0.00000036
100%		+10	836,599,998	-0.001	-0.00000012
100%		+20	836,599,997	-0.002	-0.00000024
100%		+30	836,600,002	0.004	0.00000036
100%		+40	836,599,997	-0.002	-0.00000024
100%		+50	836,599,999	0.000	0.00000000
115%	4.370	+25	836,600,001	0.002	0.00000024
BATT.ENDPOINT	3.400	+25	836,599,998	-0.001	-0.00000012

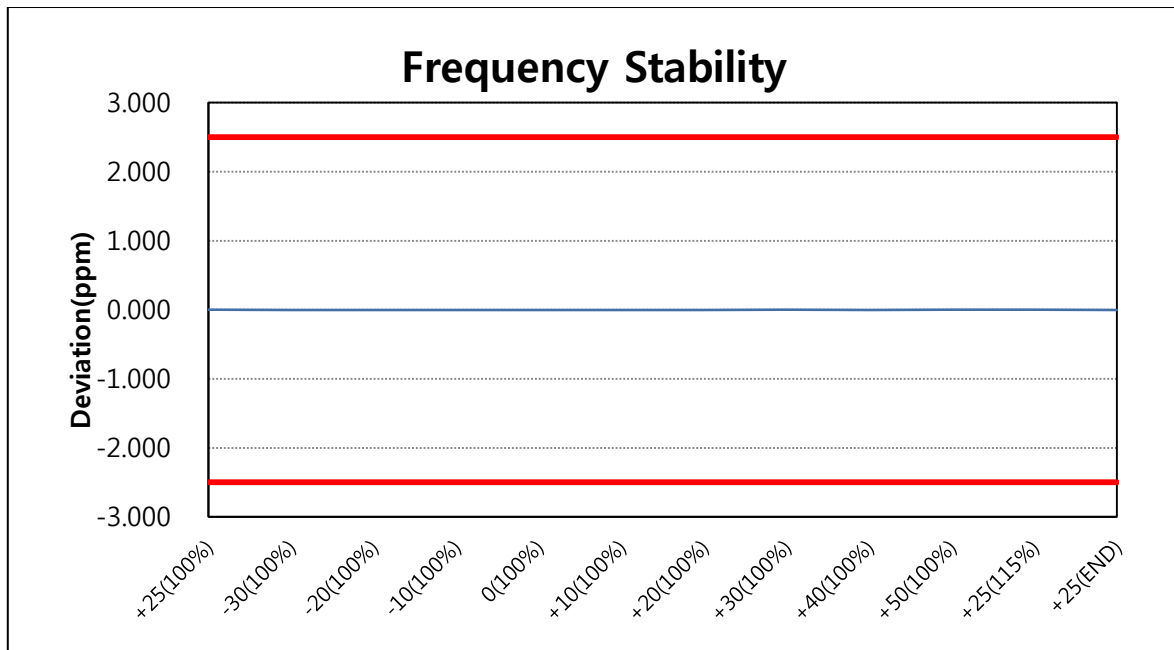

7.8.3 FREQUENCY STABILITY (HSUPA850)

OPERATING FREQUENCY : 836,599,997 Hz
 CHANNEL : 4183(Mid)
 REFERENCE VOLTAGE : 3.800 V DC
 DEVIATION LIMIT : $\pm 0.00025\%$ or 2.5 ppm

VOLTAGE (%)	POWER (V DC)	TEMP (°C)	FREQ (Hz)	Deviation	
				(ppm)	(%)
100%	3.800	+25(Ref)	836,599,997	0.000	0.00000000
100%		-30	836,599,998	0.001	0.00000012
100%		-20	836,600,001	0.005	0.00000048
100%		-10	836,599,996	-0.001	-0.00000012
100%		0	836,599,998	0.001	0.00000012
100%		+10	836,599,997	0.000	0.00000000
100%		+20	836,600,002	0.006	0.00000060
100%		+30	836,599,996	-0.001	-0.00000012
100%		+40	836,599,997	0.000	0.00000000
100%		+50	836,600,001	0.005	0.00000048
115%	4.370	+25	836,599,998	0.001	0.00000012
BATT.ENDPOINT	3.400	+25	836,599,997	0.000	0.00000000

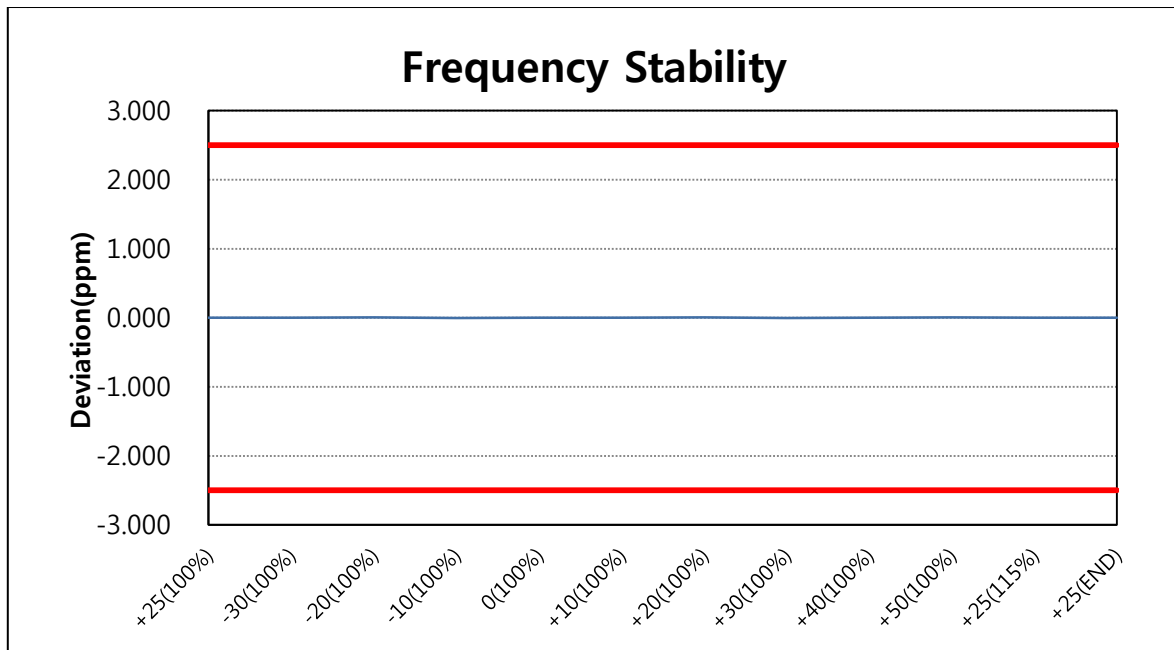

7.8.4 FREQUENCY STABILITY (GSM1900)

OPERATING FREQUENCY : 1,880,000,048 Hz
 CHANNEL : 661(Mid)
 REFERENCE VOLTAGE : 3.800 V DC
 LIMIT : The frequency stability shall be sufficient to ensure that the fundamental emission stays within the authorized frequency block.

VOLTAGE (%)	POWER (V DC)	TEMP (°C)	FREQ (Hz)	Deviation	
				(ppm)	(%)
100%	3.800	+25(Ref)	1,880,000,048	0.000	0.00000000
100%		-30	1,880,000,052	0.002	0.00000021
100%		-20	1,880,000,046	-0.001	-0.00000011
100%		-10	1,880,000,047	-0.001	-0.00000005
100%		0	1,880,000,051	0.002	0.00000016
100%		+10	1,880,000,044	-0.002	-0.00000021
100%		+20	1,880,000,054	0.003	0.00000032
100%		+30	1,880,000,052	0.002	0.00000021
100%		+40	1,880,000,048	0.000	0.00000000
100%		+50	1,880,000,050	0.001	0.00000011
115%	4.370	+25	1,880,000,053	0.003	0.00000027
BATT.ENDPOINT	3.400	+25	1,880,000,049	0.001	0.00000005

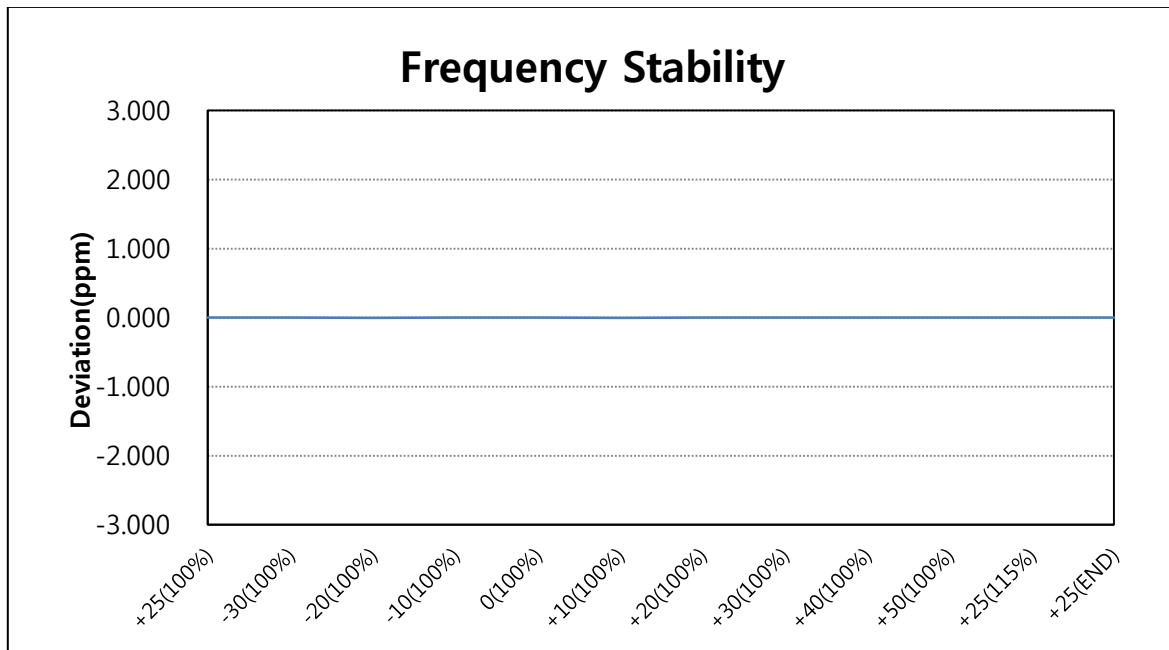

Note. Based on the results of the frequency stability test at the center channel the frequency deviation results measured are very small. as such it is determined that the channels at the band edge would remain inband when the maximum measured frequency deviation noted during the frequency stability tests is applied. therefore the device is determined to remain operating in band over the temperature and voltage range as tested.

7.9.5 FREQUENCY STABILITY (WCDMA1900)

OPERATING FREQUENCY : 1,879,999,997 Hz
 CHANNEL : 9400(Mid)
 REFERENCE VOLTAGE : 3.800 V DC
 LIMIT : The frequency stability shall be sufficient to ensure that the fundamental emission stays within the authorized frequency block.

VOLTAGE (%)	POWER (V DC)	TEMP (°C)	FREQ (Hz)	Deviation	
				(ppm)	(%)
100%	3.800	+ 25(Ref)	1,879,999,997	0.000	0.00000000
100%		- 30	1,879,999,999	0.001	0.00000011
100%		- 20	1,879,999,997	0.000	0.00000000
100%		- 10	1,880,000,001	0.002	0.00000021
100%		0	1,879,999,998	0.001	0.00000005
100%		+ 10	1,880,000,002	0.003	0.00000027
100%		+ 20	1,879,999,996	-0.001	-0.00000005
100%		+ 30	1,879,999,999	0.001	0.00000011
100%		+ 40	1,879,999,998	0.001	0.00000005
100%		+ 50	1,879,999,998	0.001	0.00000005
115%		4.370	+ 25	1,880,000,001	0.002
BATT.ENDPOINT	3.400	+ 25	1,879,999,998	0.001	0.00000005

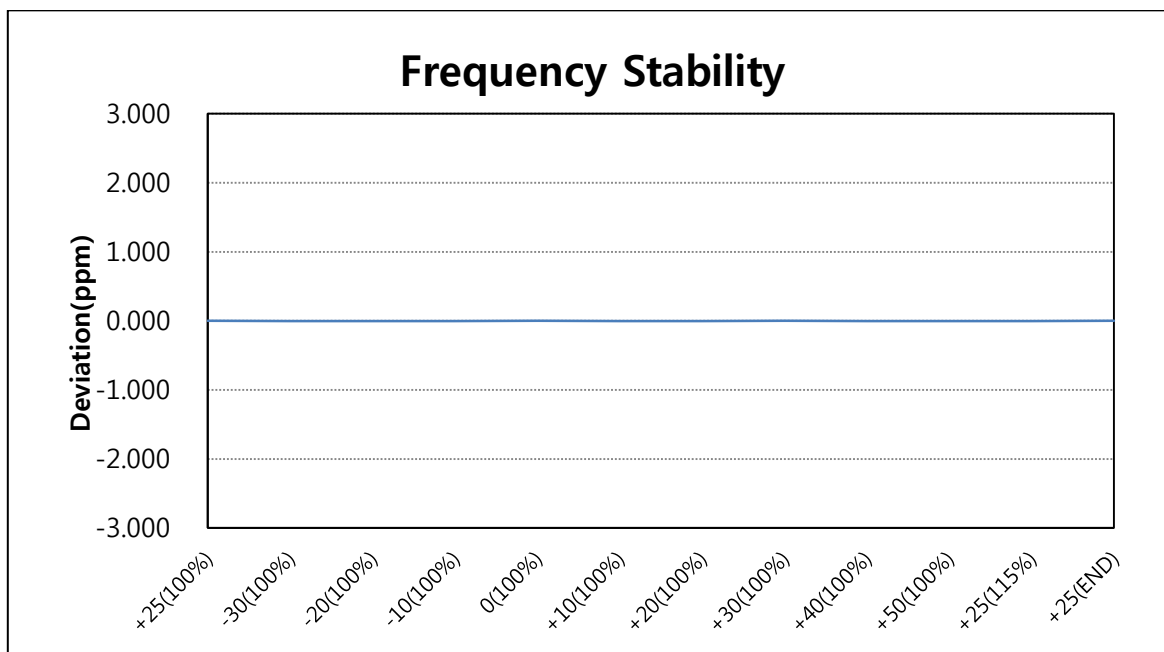

Note. Based on the results of the frequency stability test at the center channel the frequency deviation results measured are very small. as such it is determined that the channels at the band edge would remain inband when the maximum measured frequency deviation noted during the frequency stability tests is applied. therefore the device is determined to remain operating in band over the temperature and voltage range as tested.

7.9.4 FREQUENCY STABILITY (HSUPA1900)

OPERATING FREQUENCY : 1,888,000,006 Hz
 CHANNEL : 9400(Mid)
 REFERENCE VOLTAGE : 3.800 V DC
 LIMIT : The frequency stability shall be sufficient to ensure that the fundamental emission stays within the authorized frequency block.

VOLTAGE (%)	POWER (V DC)	TEMP (°C)	FREQ (Hz)	Deviation	
				(ppm)	(%)
100%	3.800	+ 25(Ref)	1,880,000,006	0.000	0.00000000
100%		- 30	1,880,000,002	-0.002	-0.00000021
100%		- 20	1,880,000,004	-0.001	-0.00000011
100%		- 10	1,880,000,001	-0.003	-0.00000027
100%		0	1,880,000,005	-0.001	-0.00000005
100%		+ 10	1,880,000,004	-0.001	-0.00000011
100%		+ 20	1,880,000,003	-0.002	-0.00000016
100%		+ 30	1,880,000,006	0.000	0.00000000
100%		+ 40	1,879,999,998	-0.004	-0.00000043
100%		+ 50	1,880,000,004	-0.001	-0.00000011
115%	4.370	+ 25	1,880,000,003	-0.002	-0.00000016
BATT.ENDPOINT	3.400	+ 25	1,880,000,005	-0.001	-0.00000005

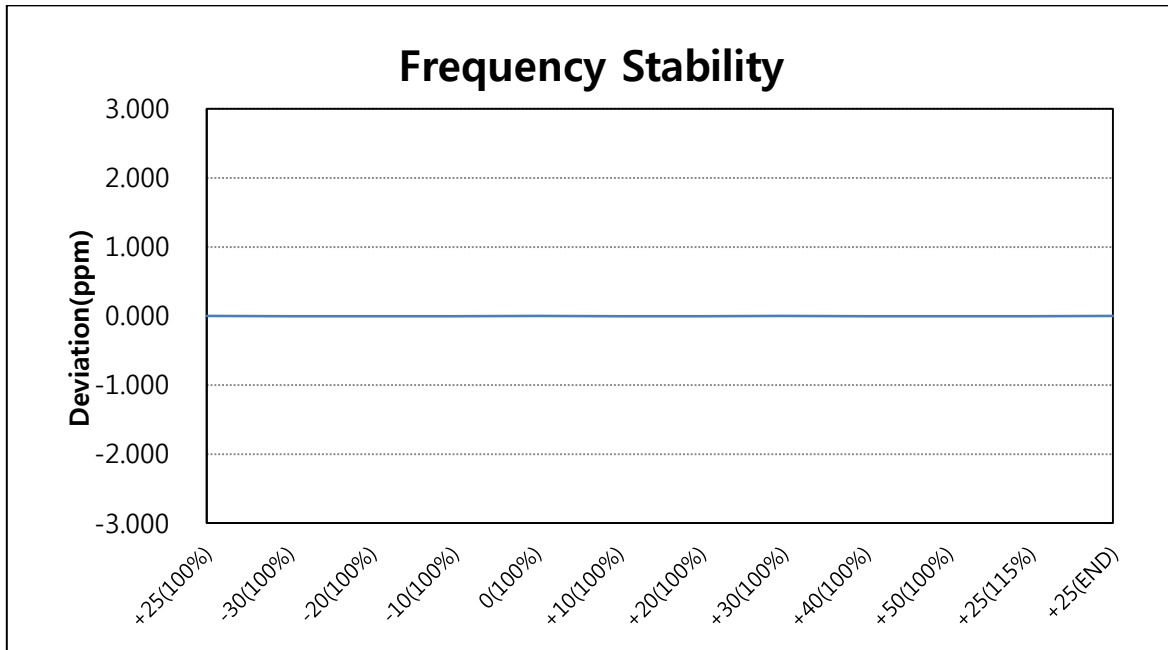

Note. Based on the results of the frequency stability test at the center channel the frequency deviation results measured are very small, as such it is determined that the channels at the band edge would remain inband when the maximum measured frequency deviation noted during the frequency stability tests is applied. therefore the device is determined to remain operating in band over the temperature and voltage range as tested.

8. TEST PLOTS

8.1 Peak to Average Ratio -P_{PK} (dBm)

GSM1900 & Channel: 661

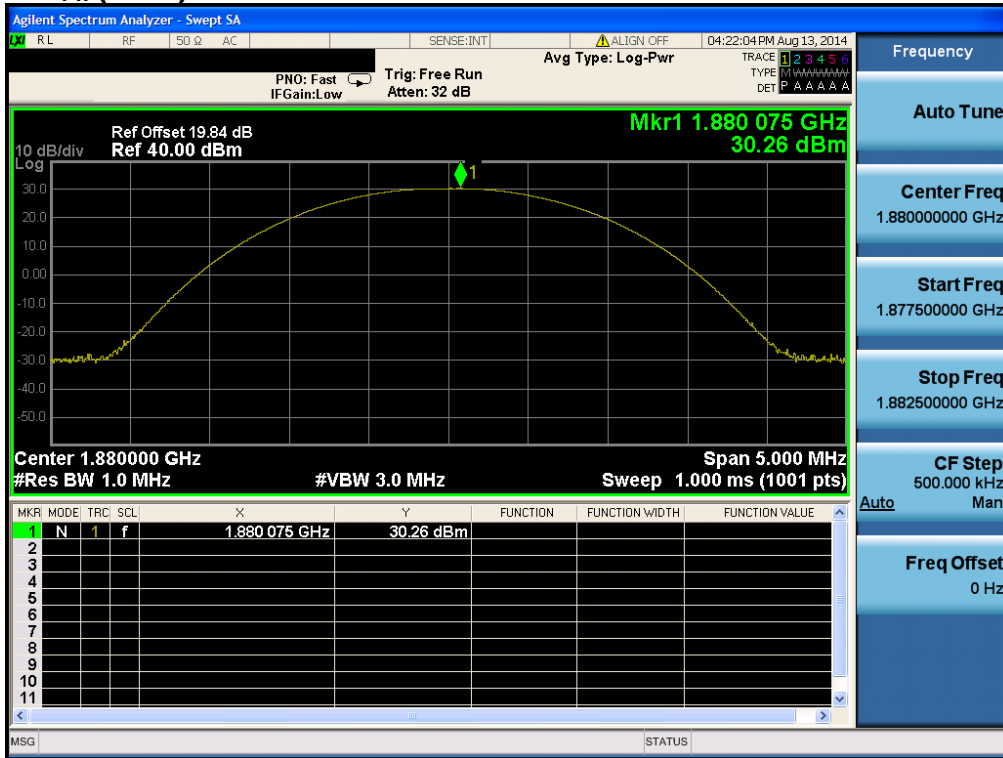

-P_{Avg} (dBm)

GSM1900 & Channel: 661



$$\text{PAPR (dB)} = P_{PK} \text{ (dBm)} - P_{Avg} \text{ (dBm)} = 30.26\text{dBm} - 30.09 \text{ dBm} = 0.17 \text{ dB}$$

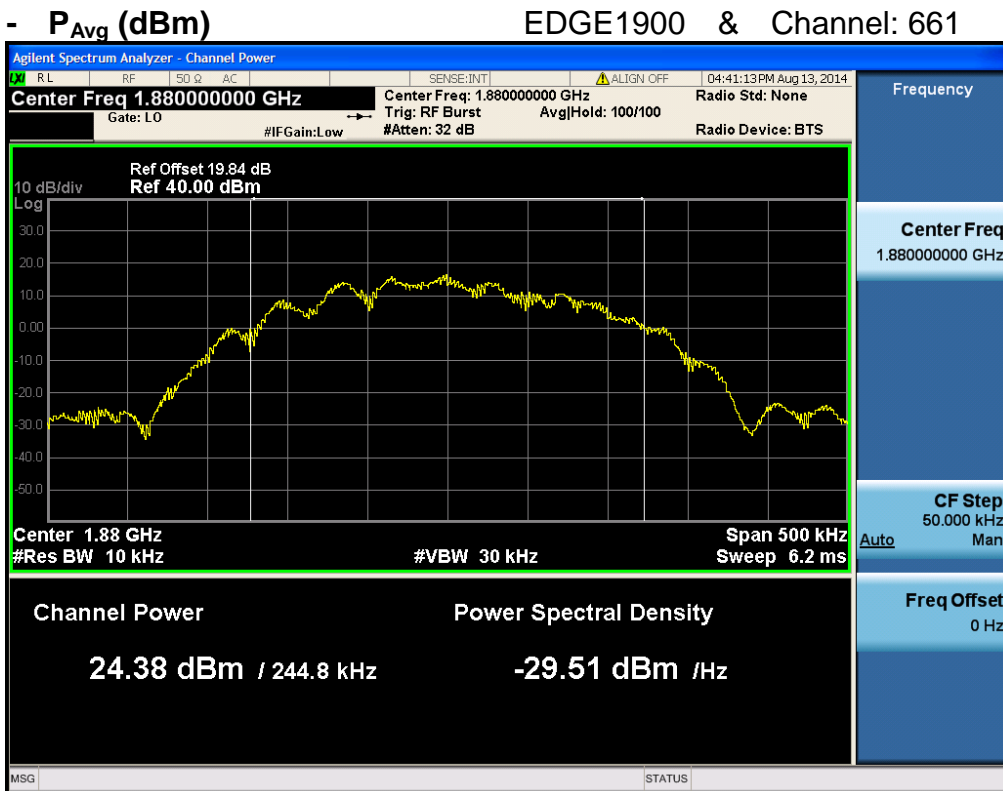
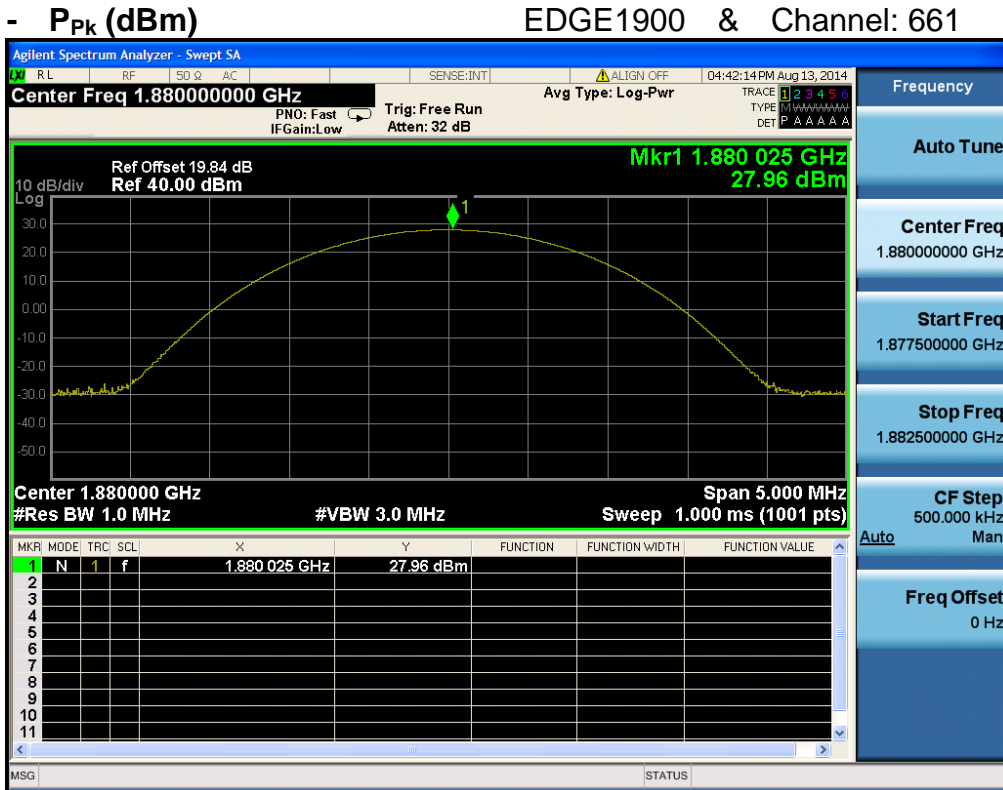

$$PAR (dB) = P_{PK} (dBm) - P_{Avg} (dBm) = 27.96 \text{ dBm} - 24.38 \text{ dBm} = 3.58 \text{ dB}$$

WCDMA1900 & Channel: 9400

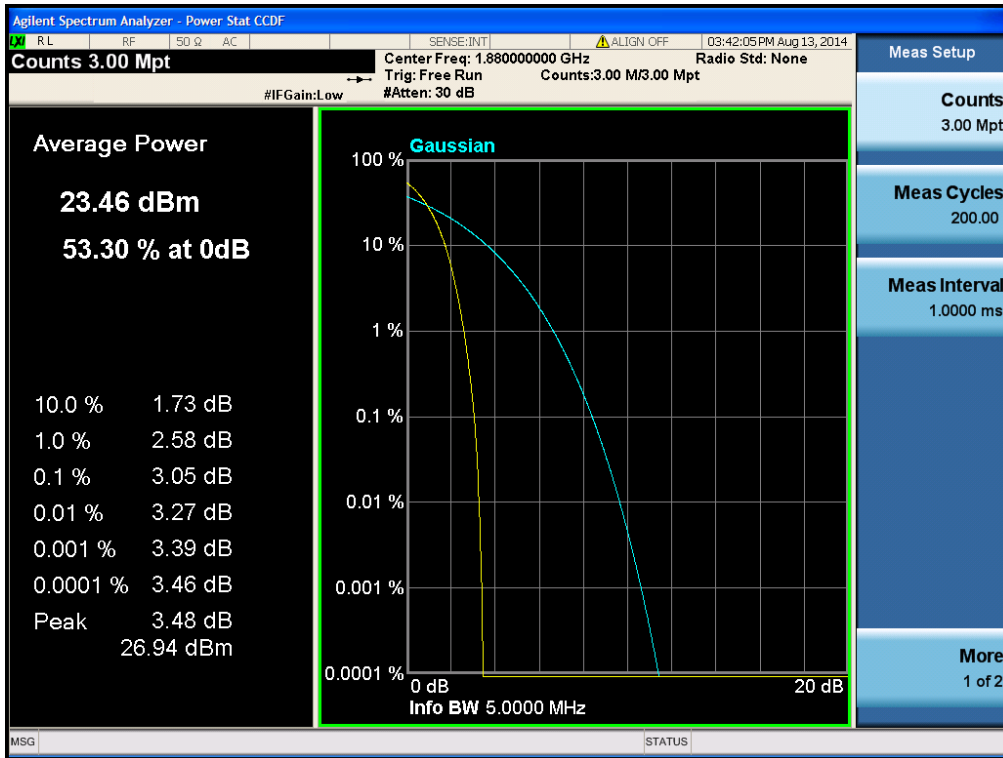

HSUPA1900 & Channel: 9400

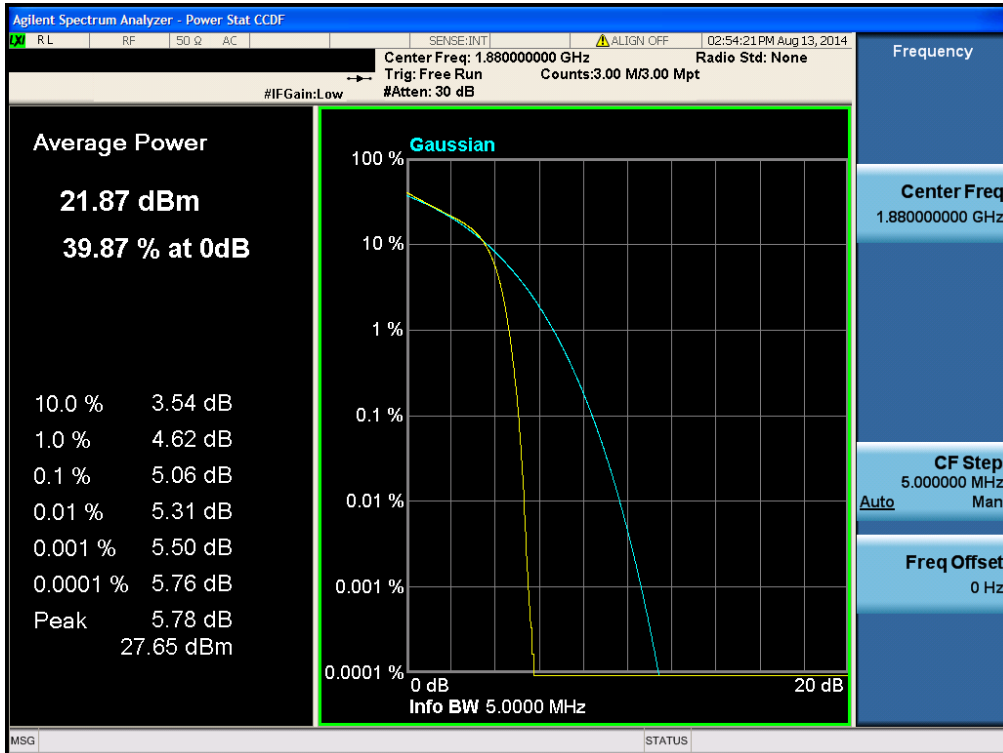

8.2 Occupied Bandwidth(99 % Bandwidth)

GSM850 & Channel: 128

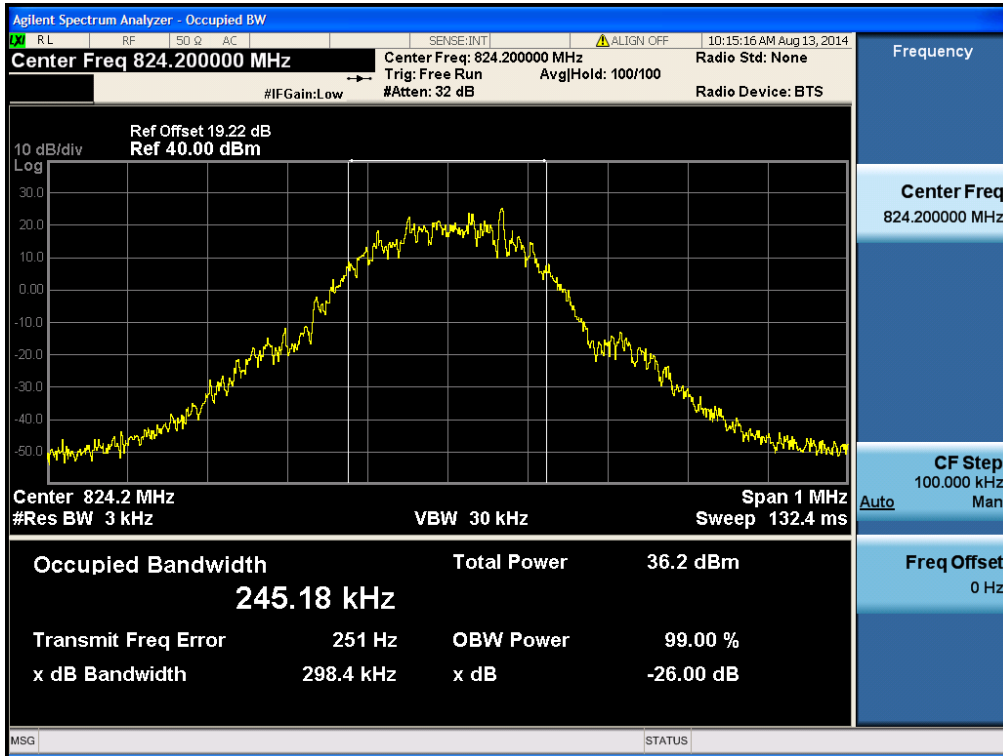

GSM850 & Channel: 190

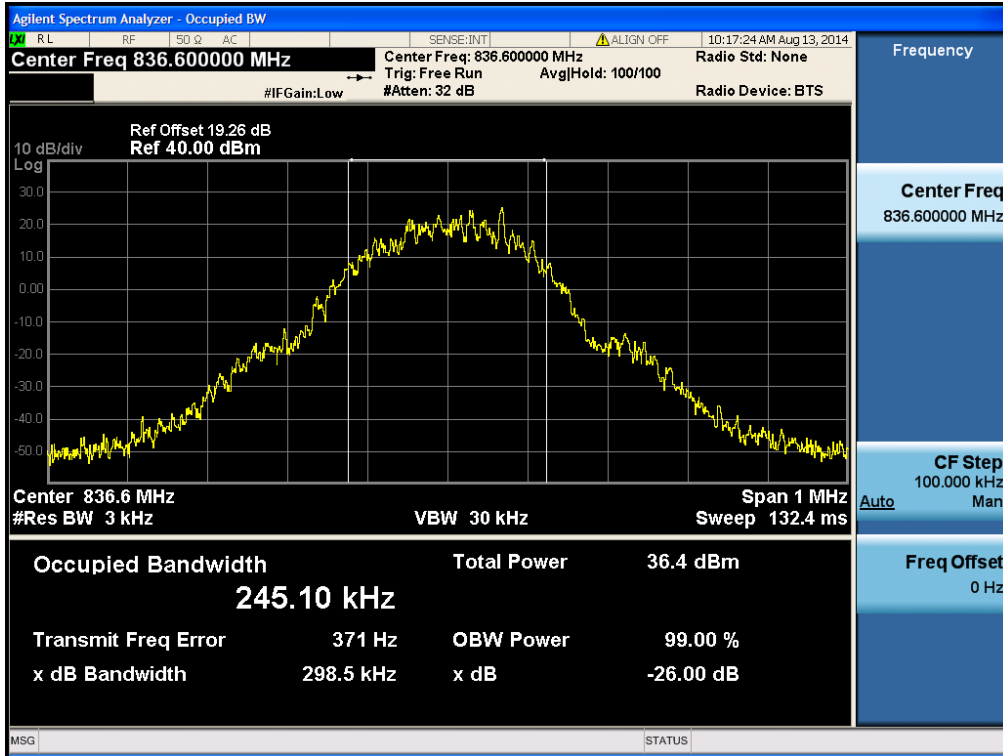

GSM850 & Channel: 251

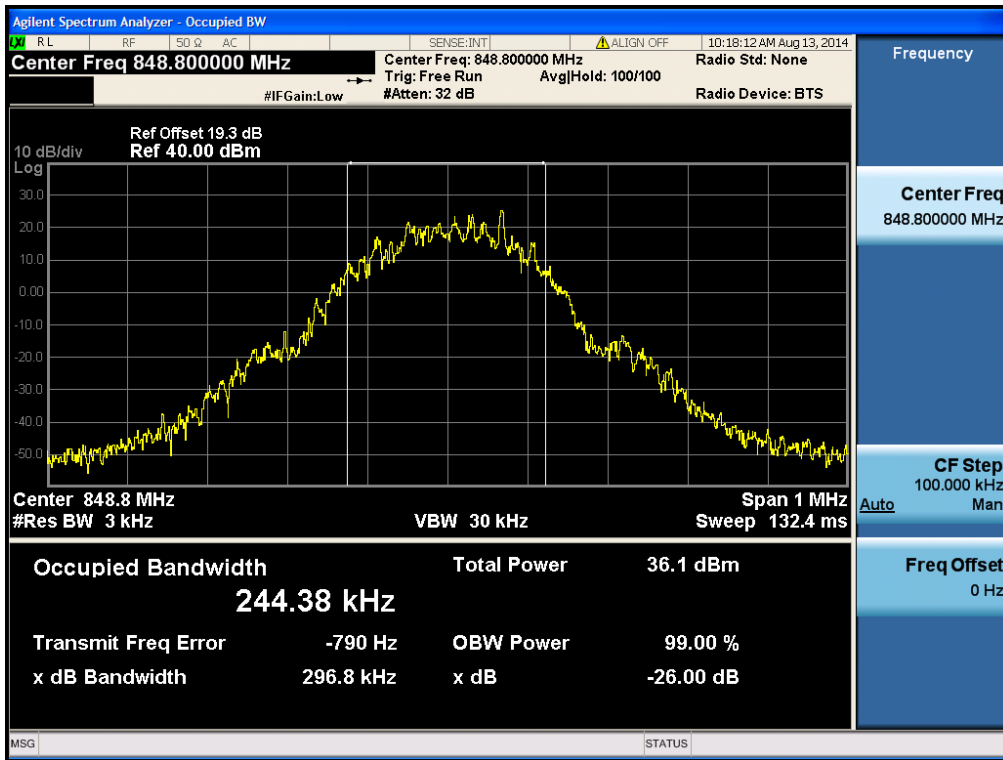

EDGE 850 & Channel: 128

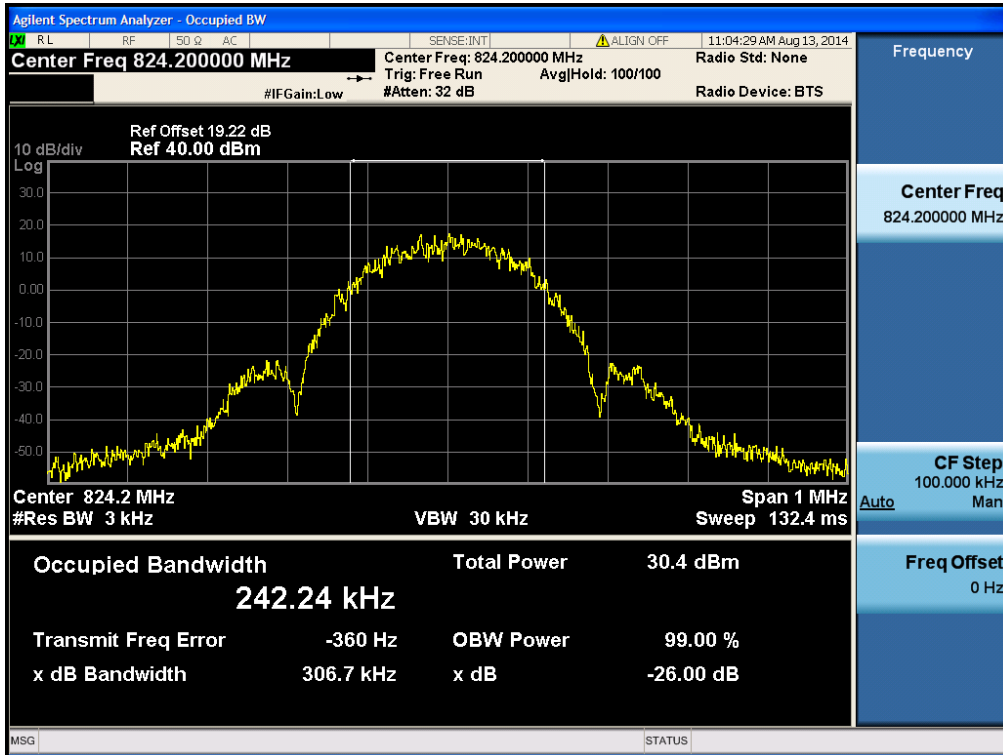

EDGE 850 & Channel: 190

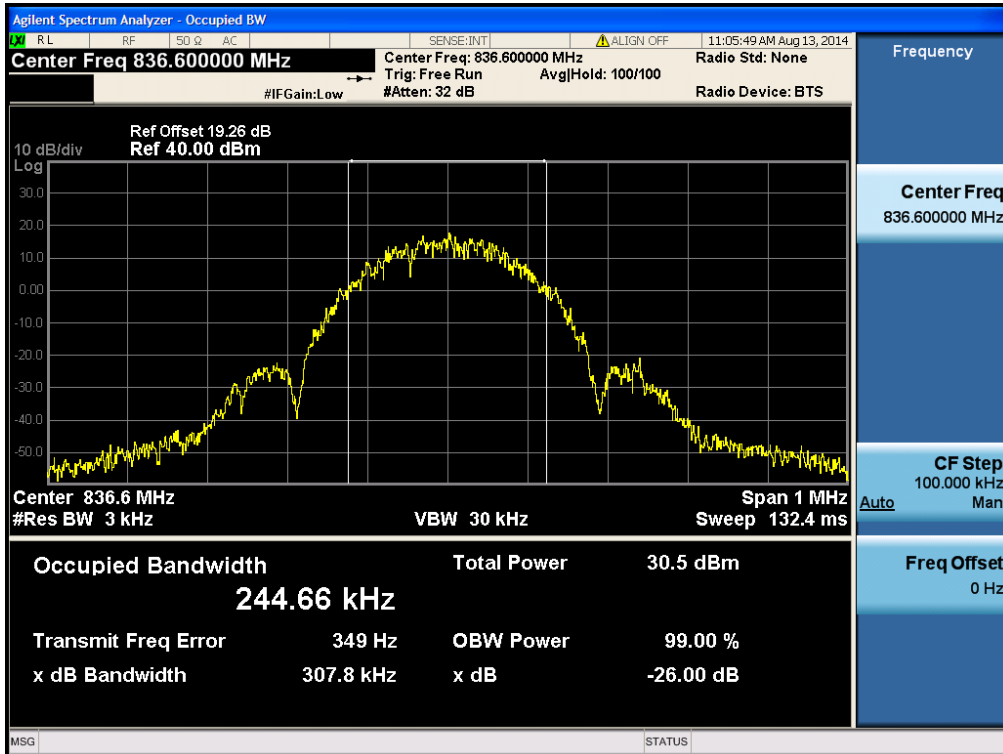

EDGE 850 & Channel: 251

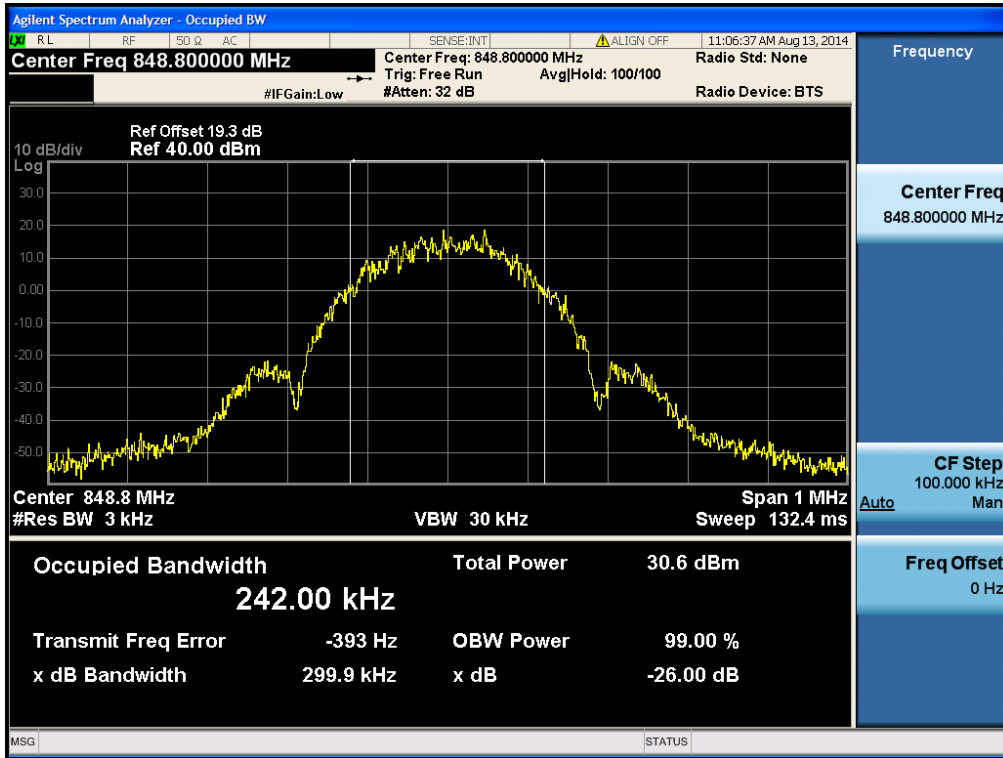

WCDMA850 & Channel: 4132

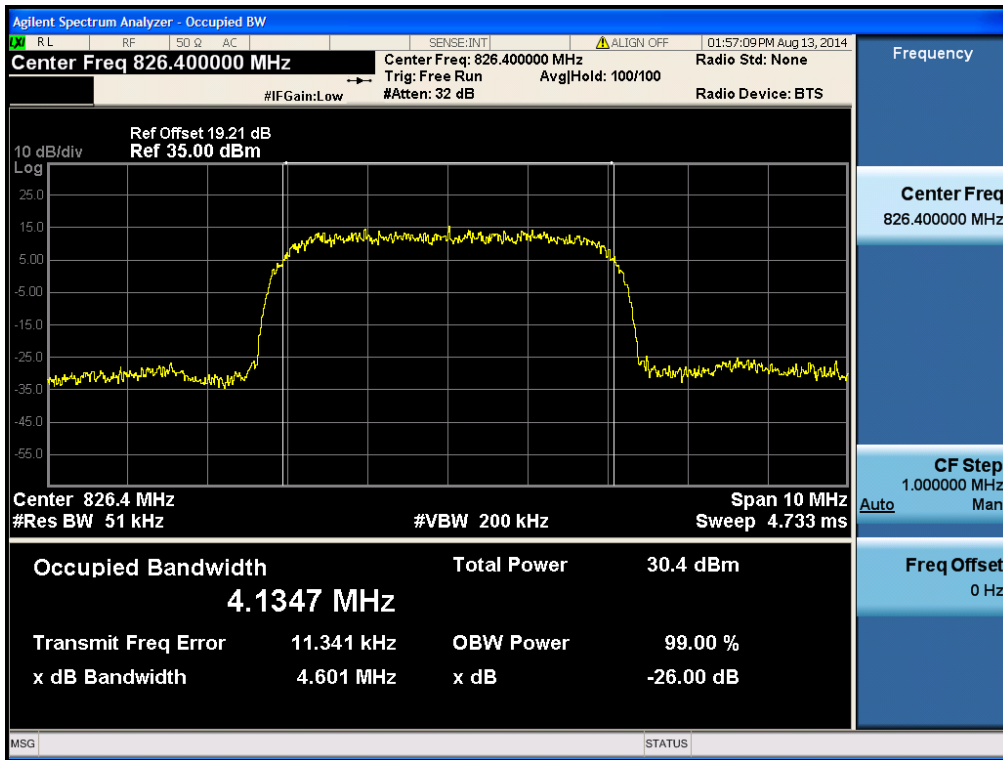

WCDMA850 & Channel: 4183

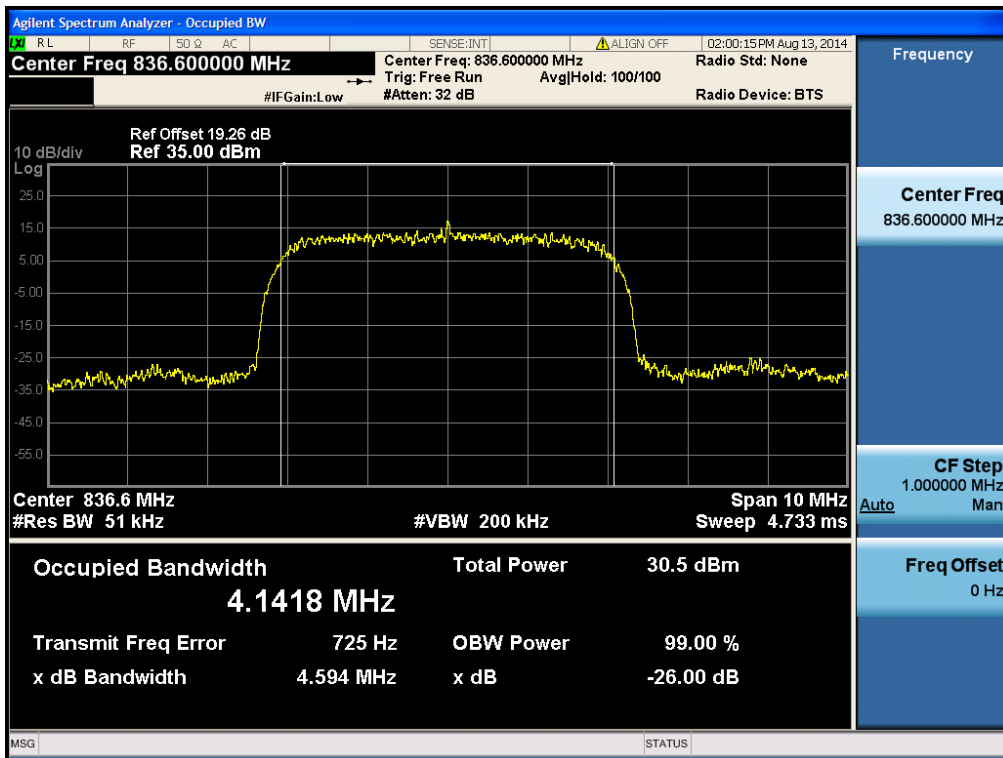

WCDMA850 & Channel: 4233

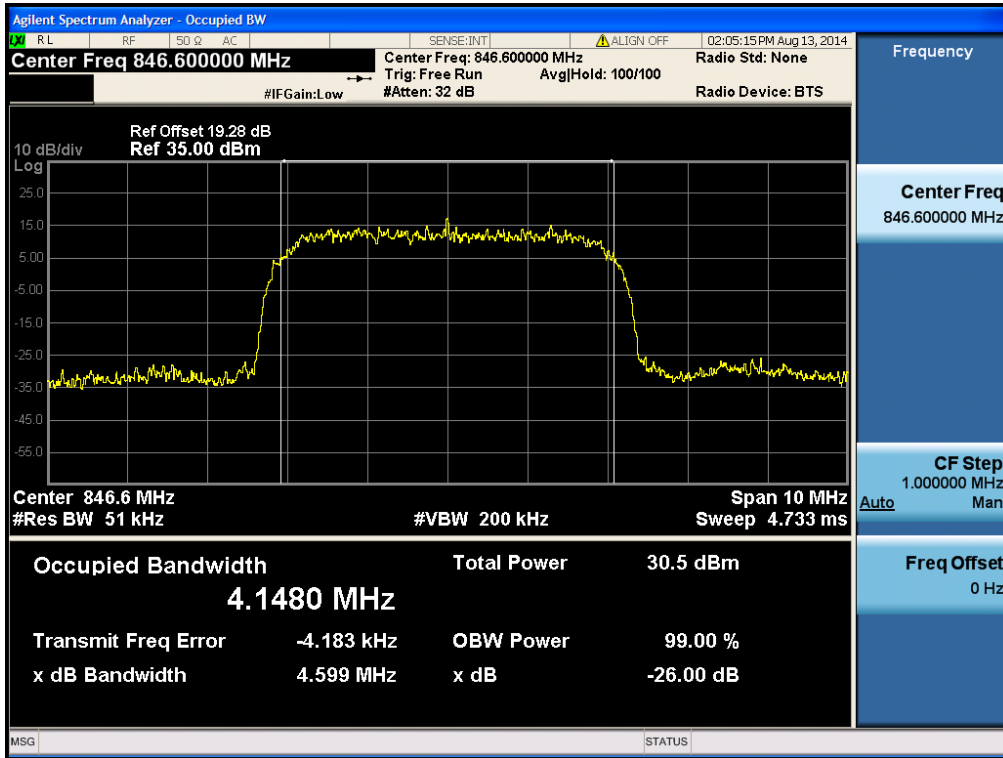

HSUPA850 & Channel: 4132

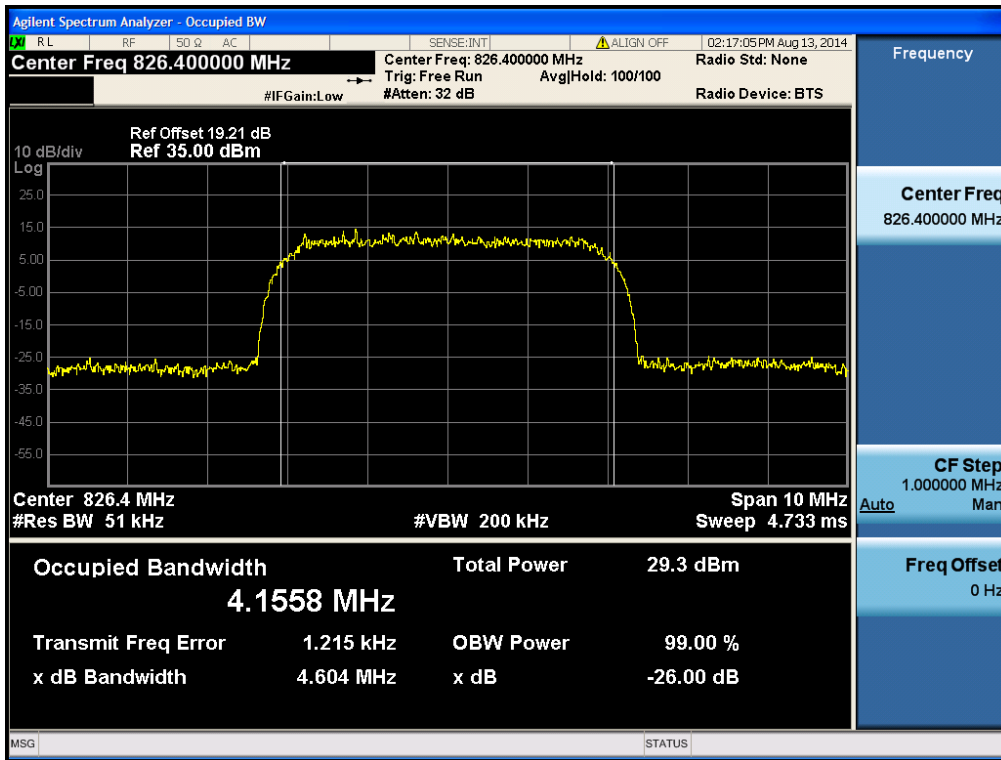

HSUPA850 & Channel: 4183

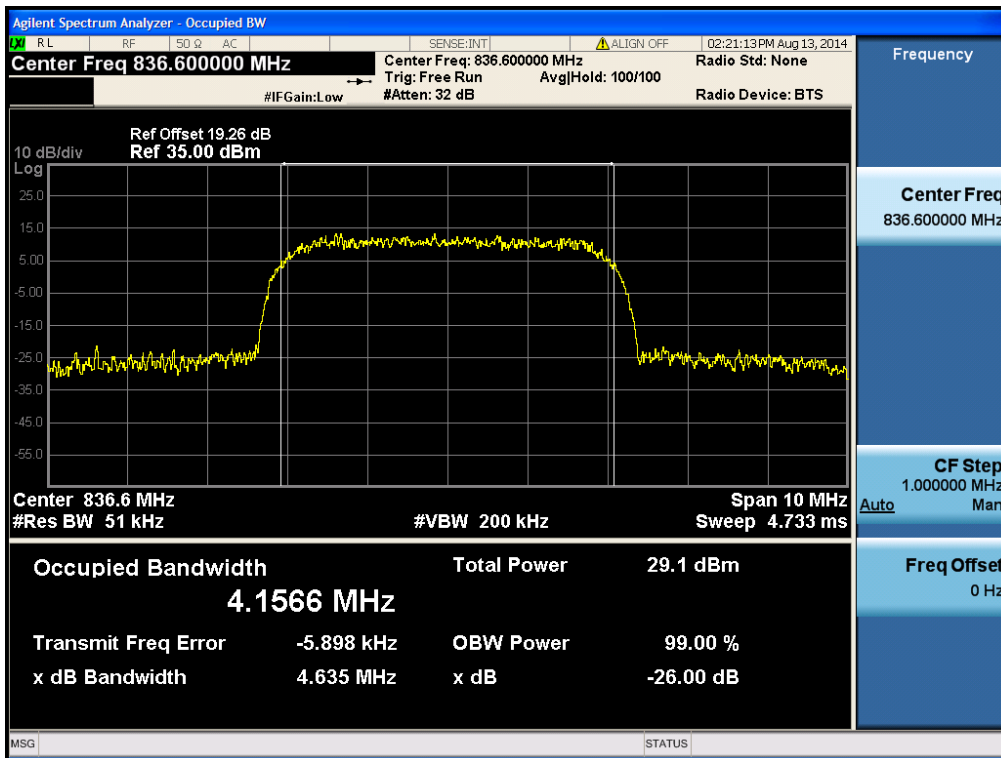

HSUPA850 & Channel: 4233

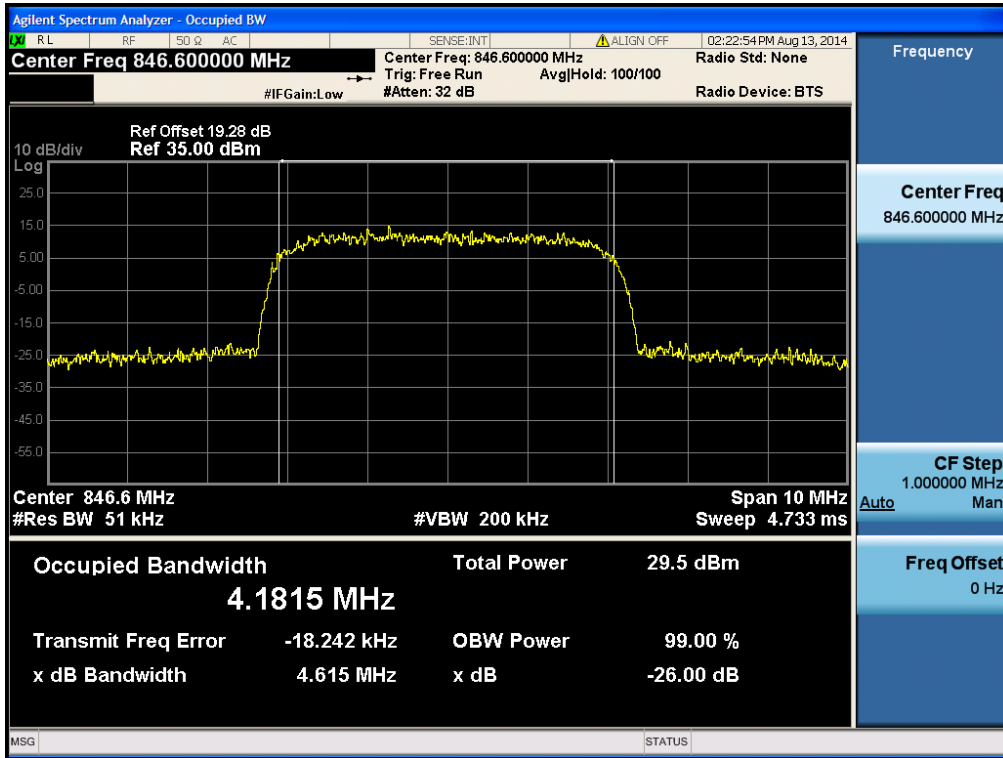

GSM 1900 & Channel: 512

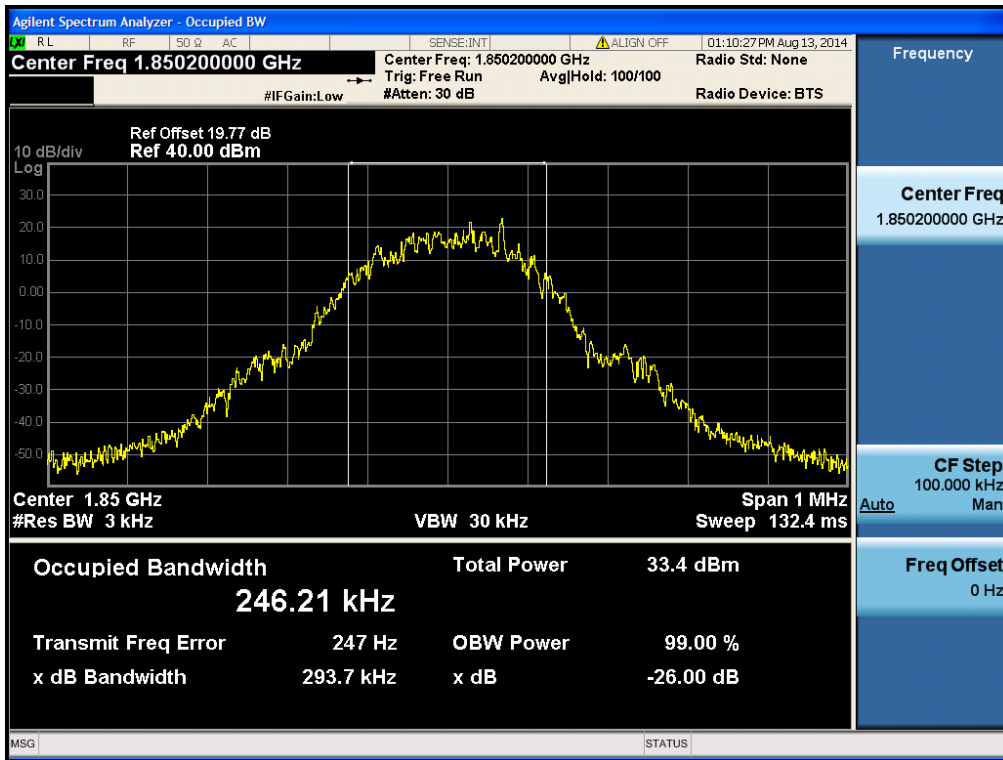

GSM 1900 & Channel: 661

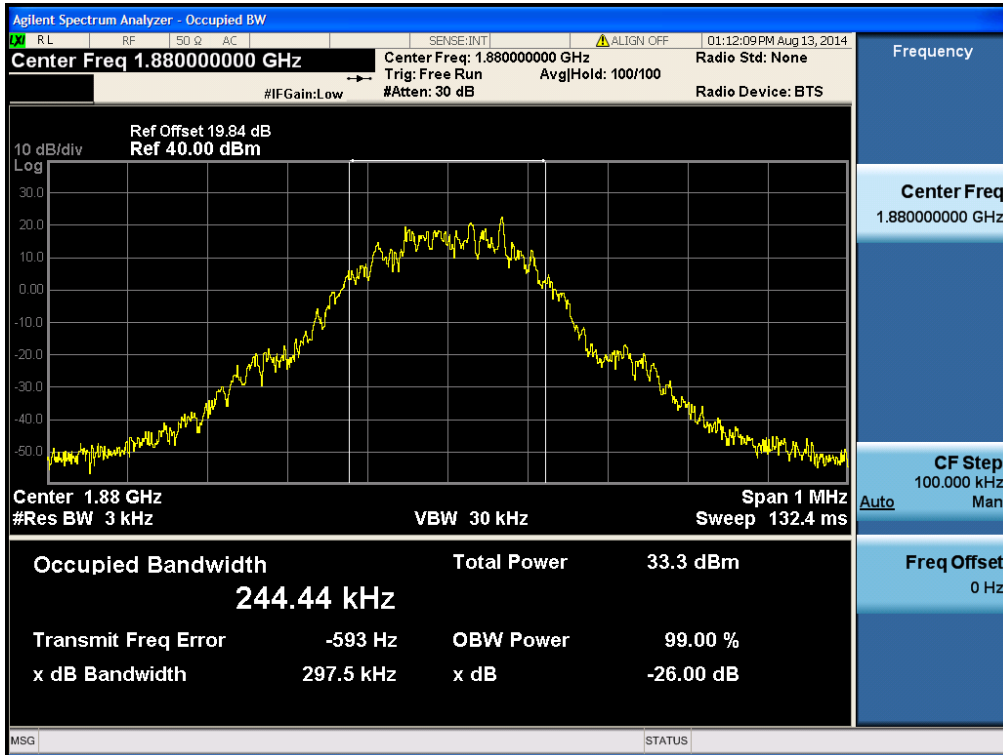

GSM 1900 & Channel: 810

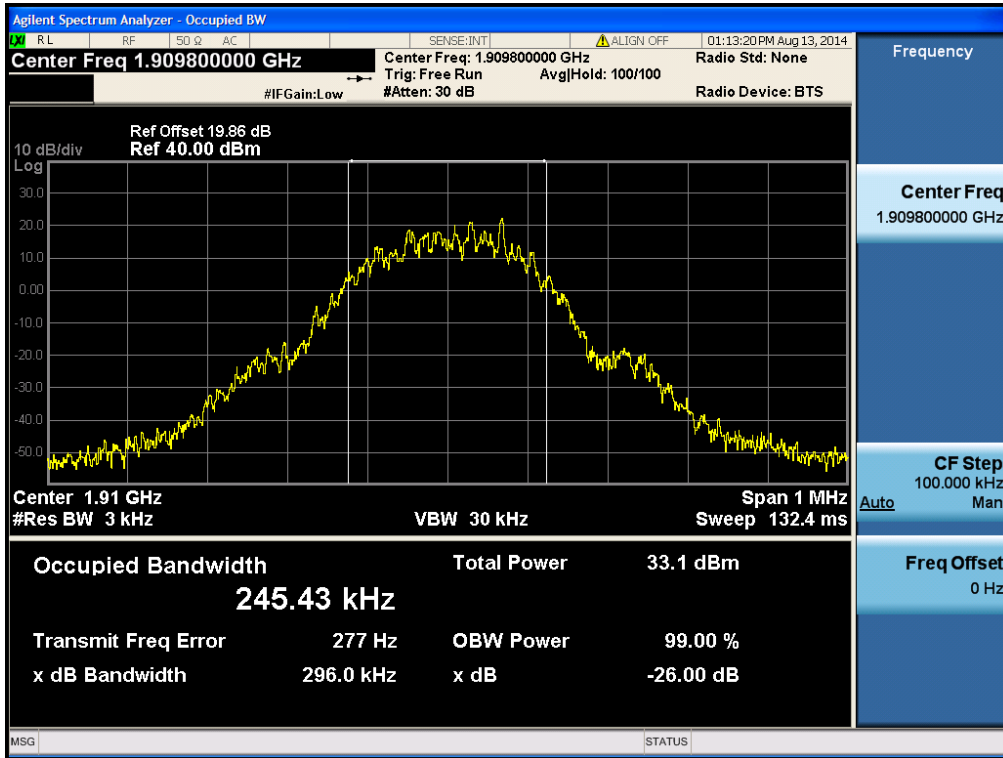

EDGE 1900 & Channel: 512

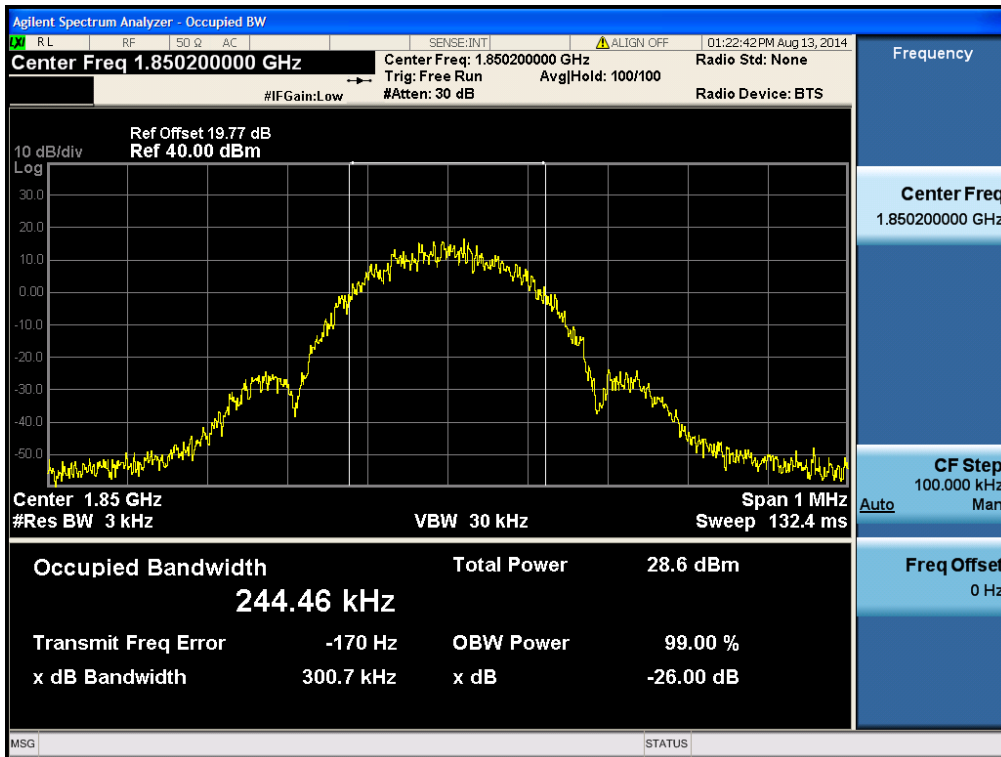

EDGE 1900 & Channel: 661

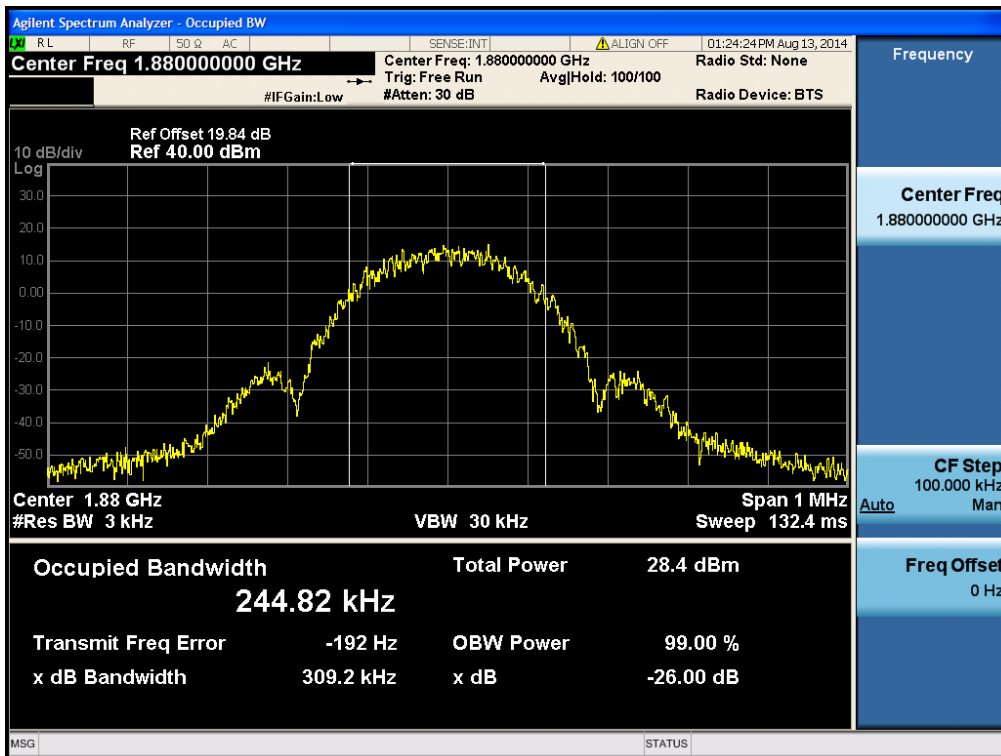

EDGE 1900 & Channel: 810

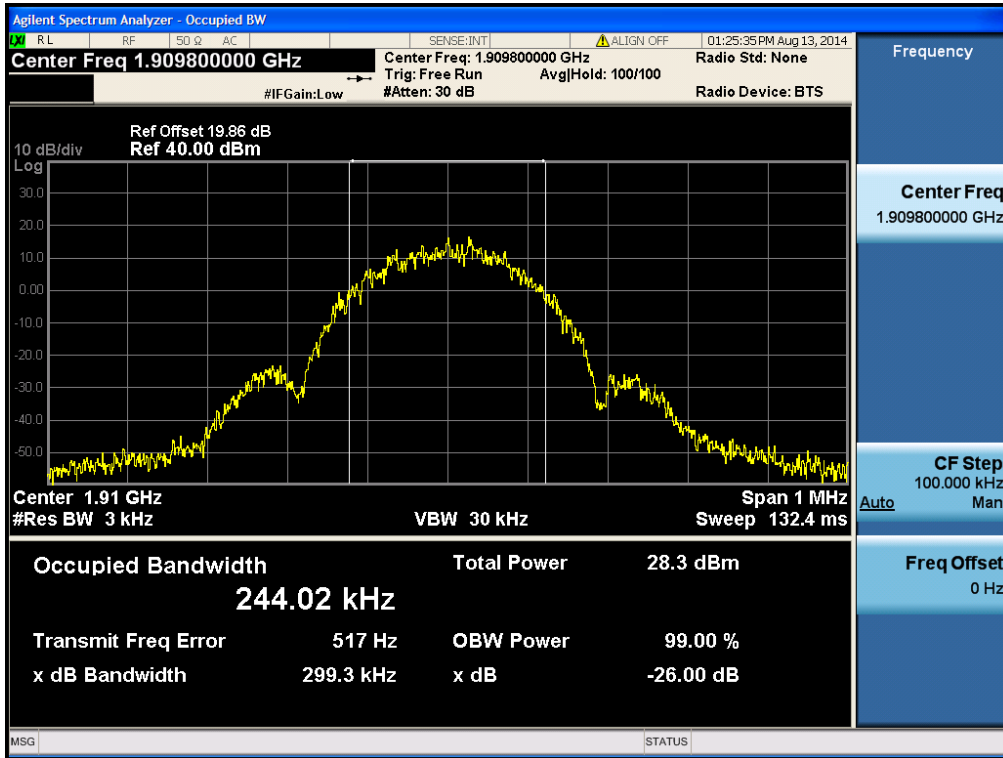

WCDMA1900 & Channel: 9262

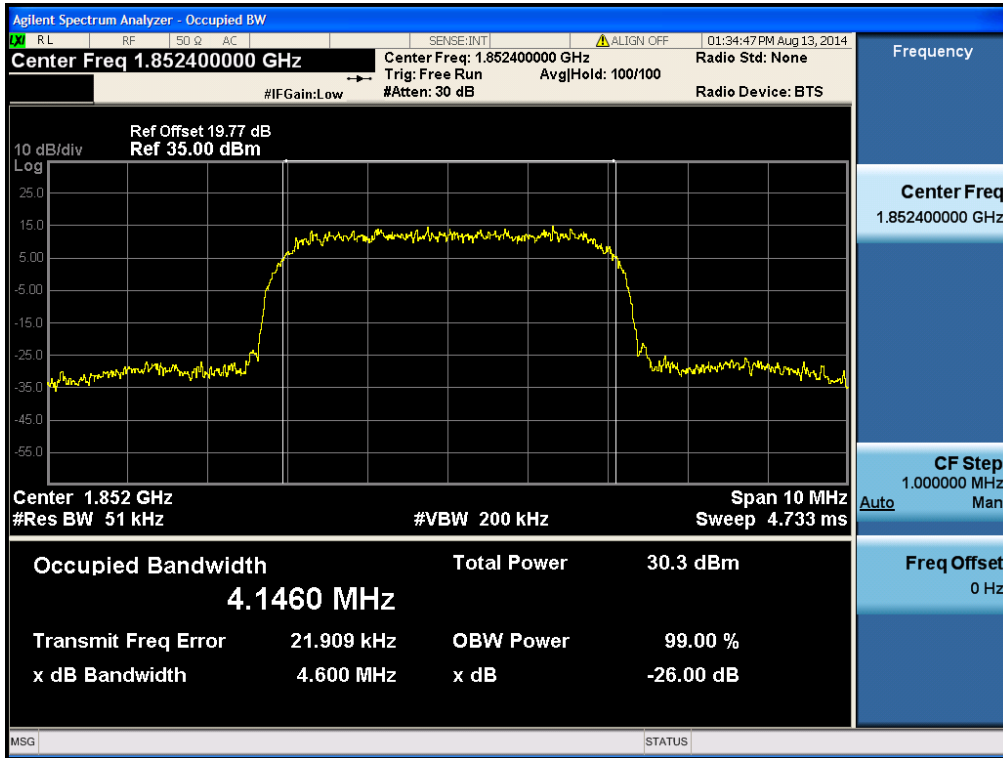

WCDMA1900 & Channel: 9400

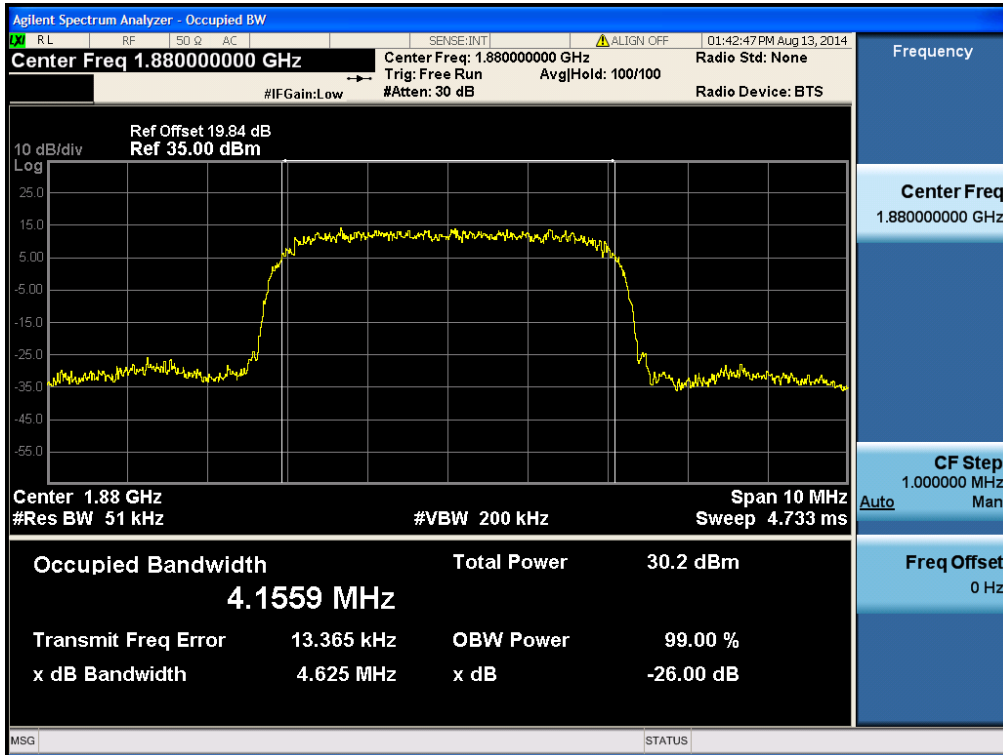

WCDMA1900 & Channel: 9538

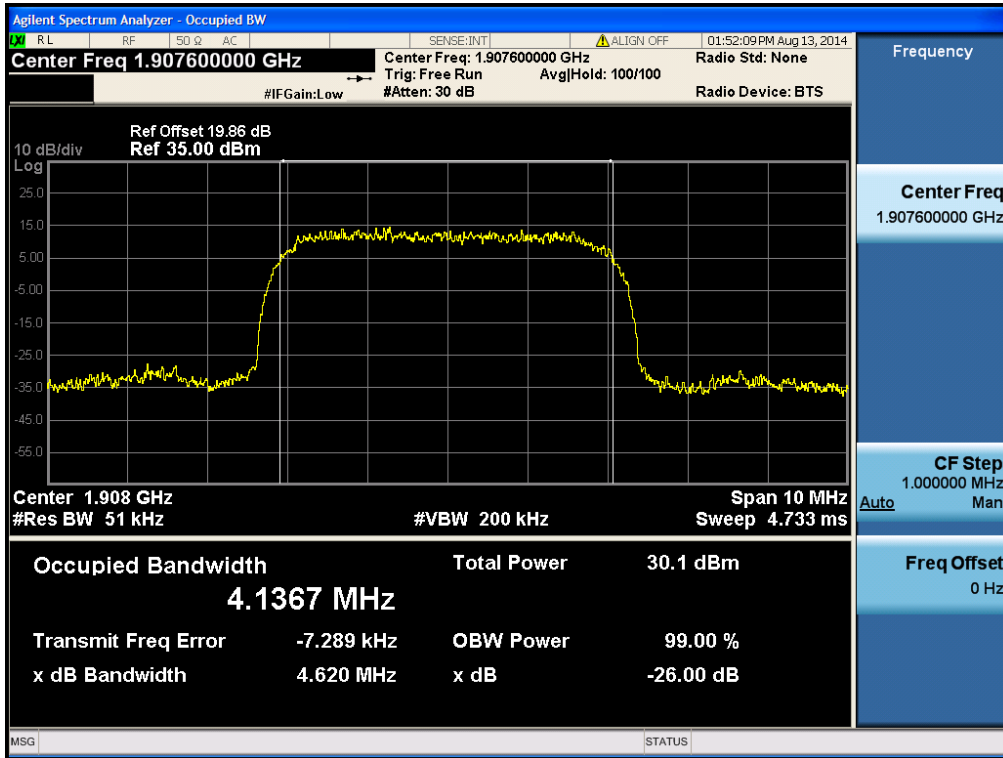

HSUPA1900 & Channel: 9262

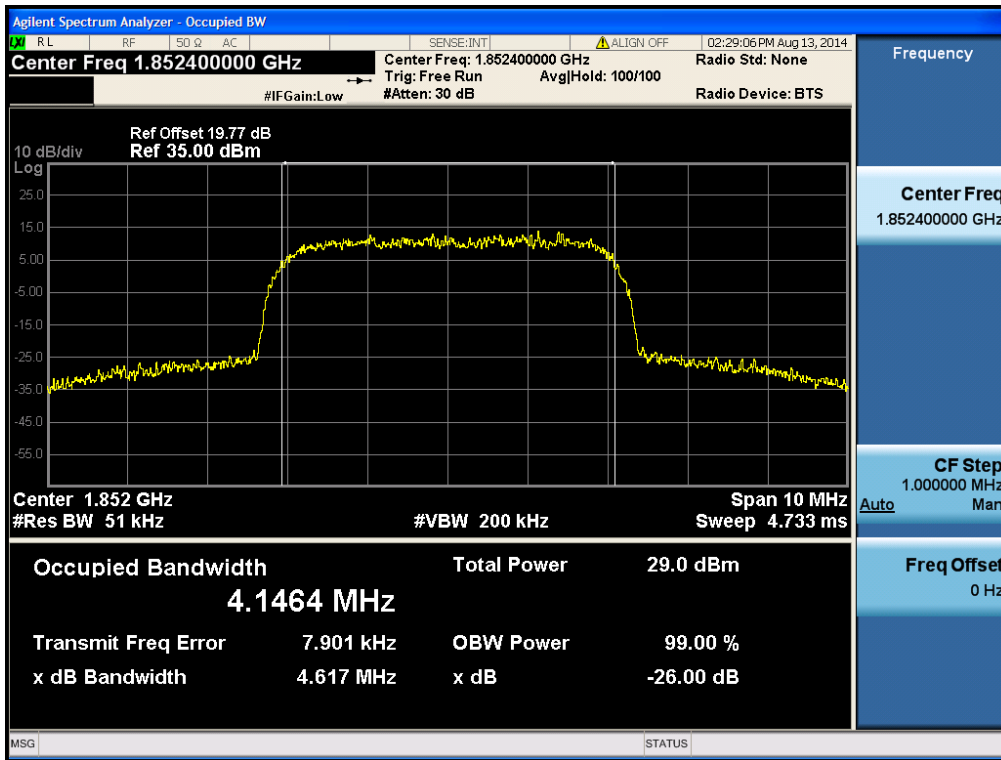

HSUPA1900 & Channel: 9400

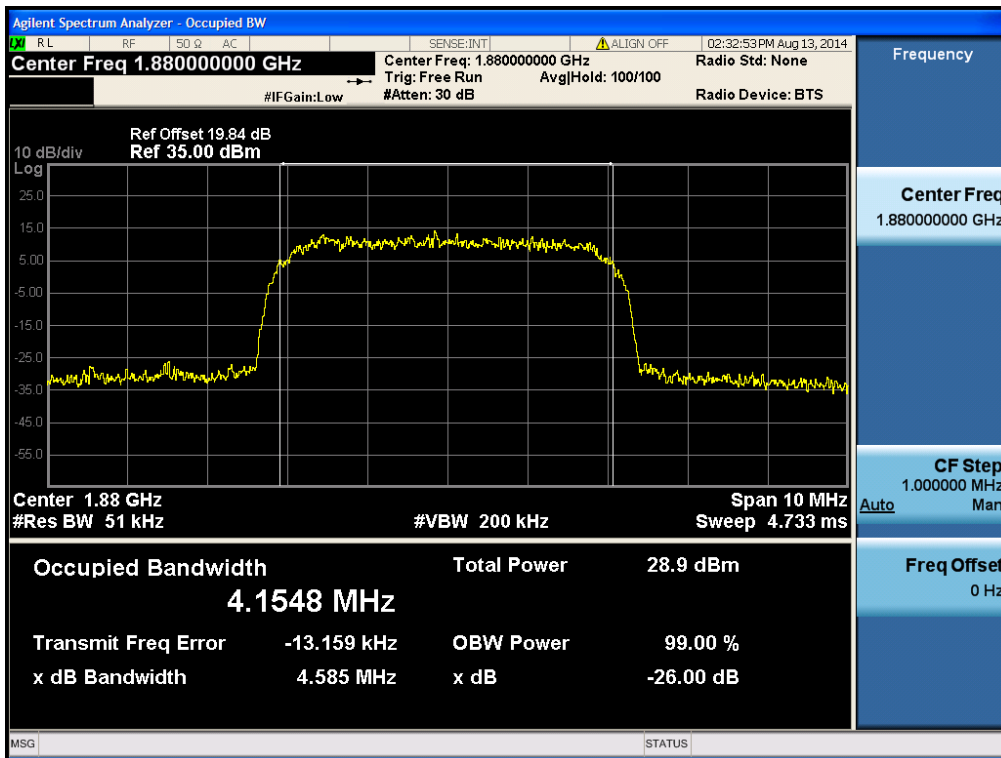

HSUPA1900 & Channel: 9538

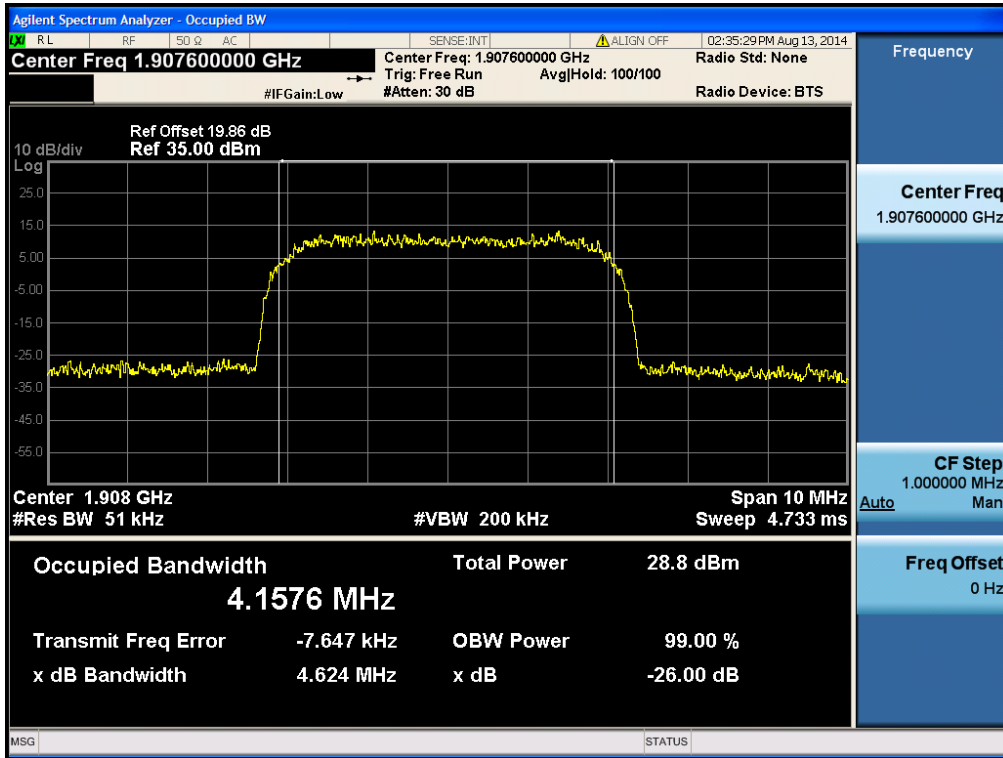

8.3 Spurious Emissions at Antenna Terminal

GSM850 & Channel: 128

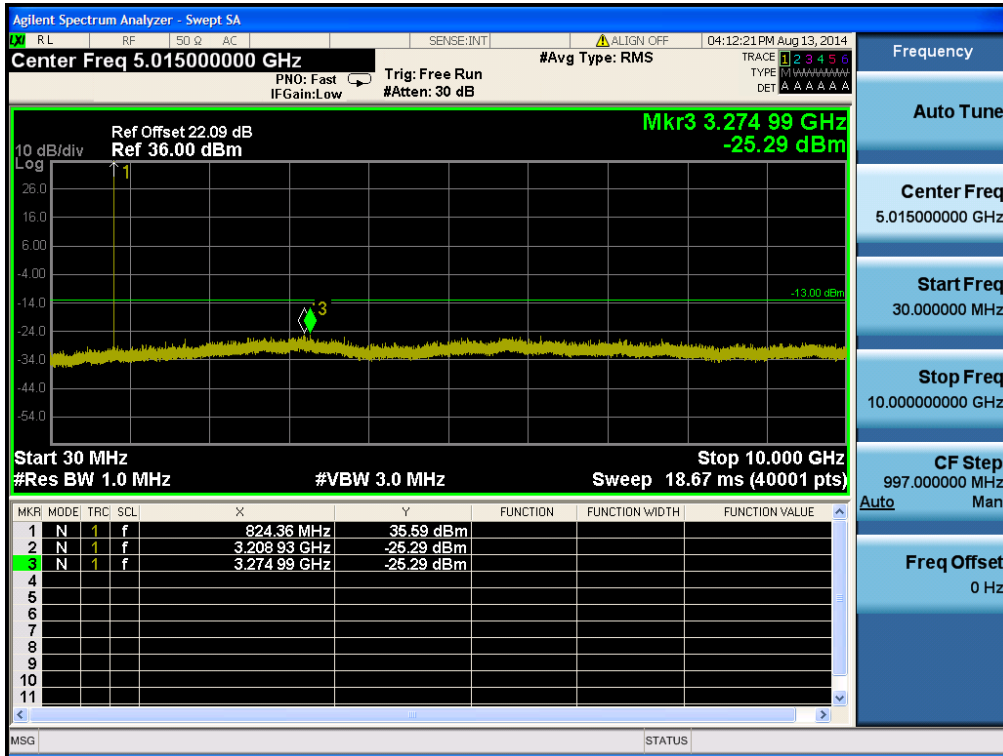

GSM850 & Channel: 190

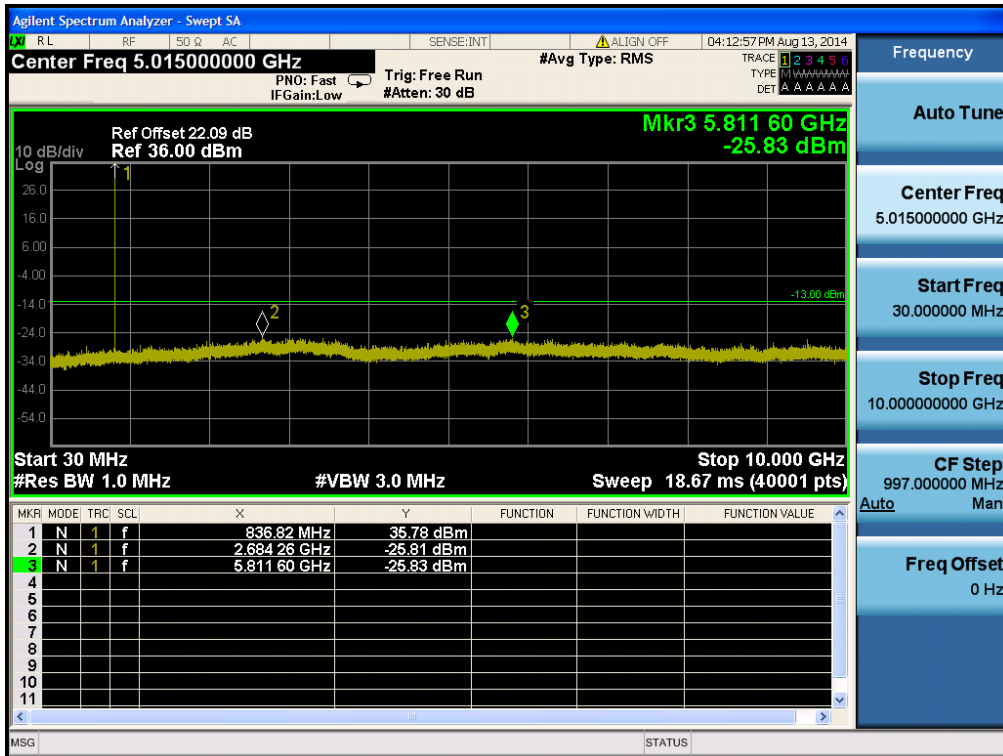

GSM850 & Channel: 251

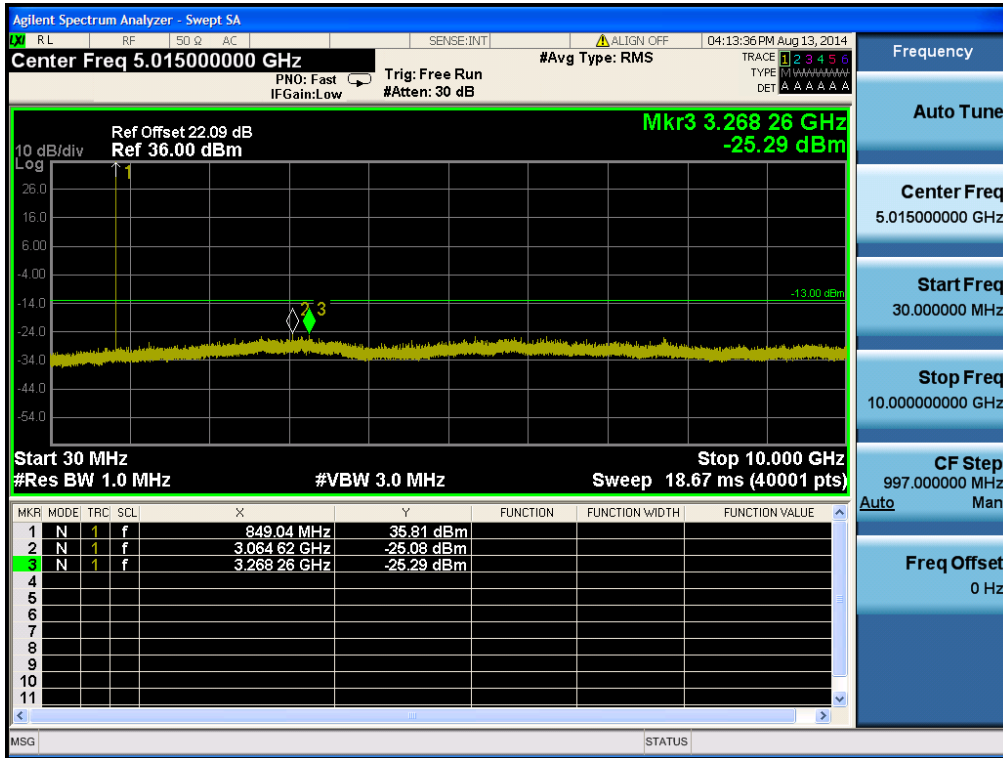

WCDMA850 & Channel: 4132

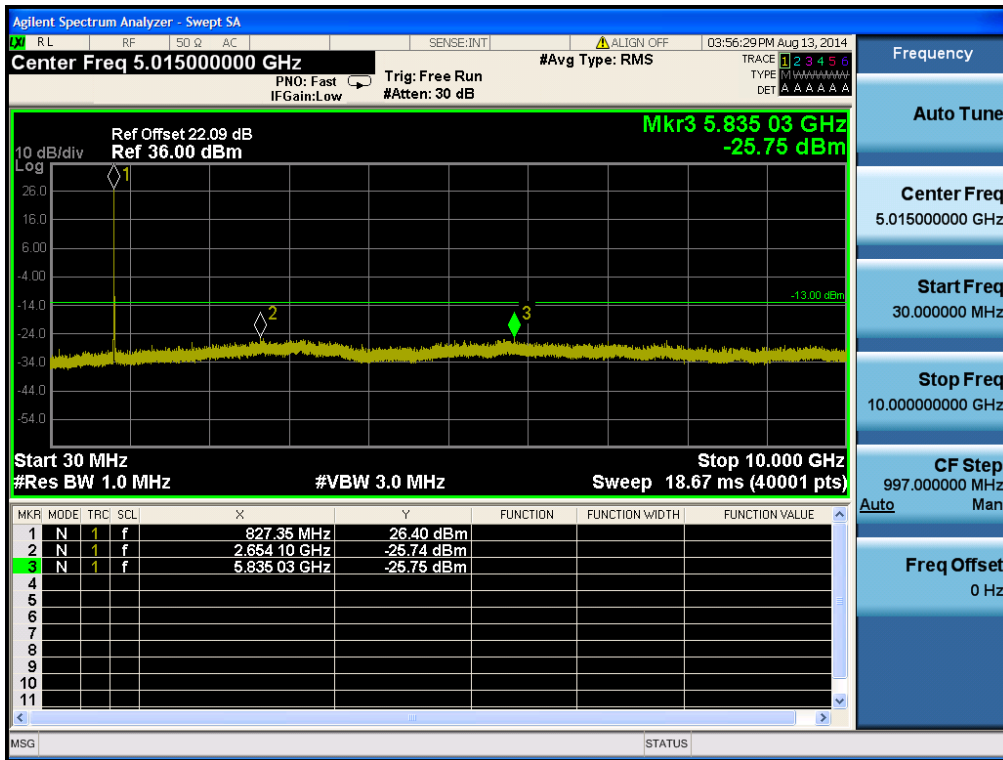

WCDMA850 & Channel: 4183

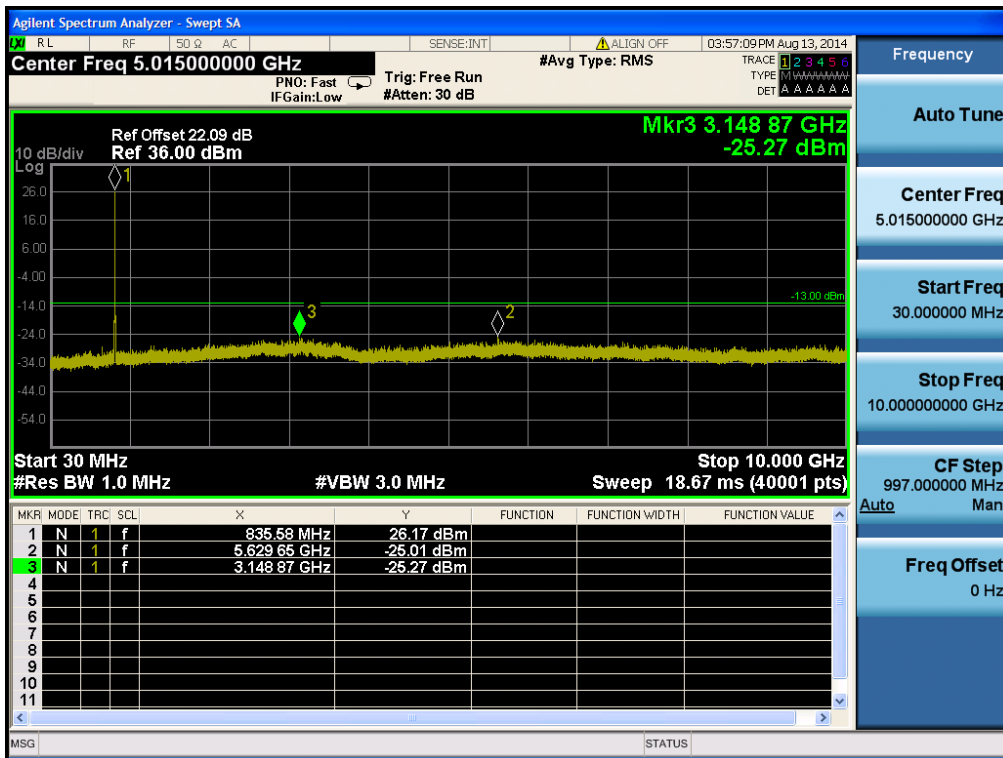

WCDMA850 & Channel: 4233

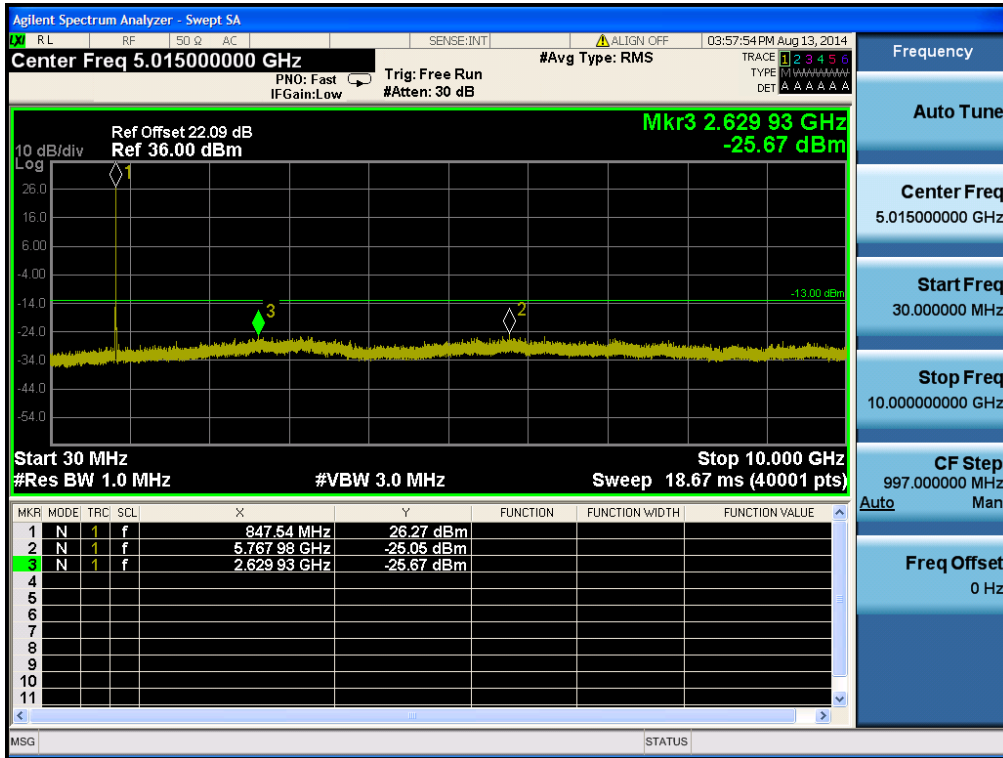

HSUPA850 & Channel: 4132

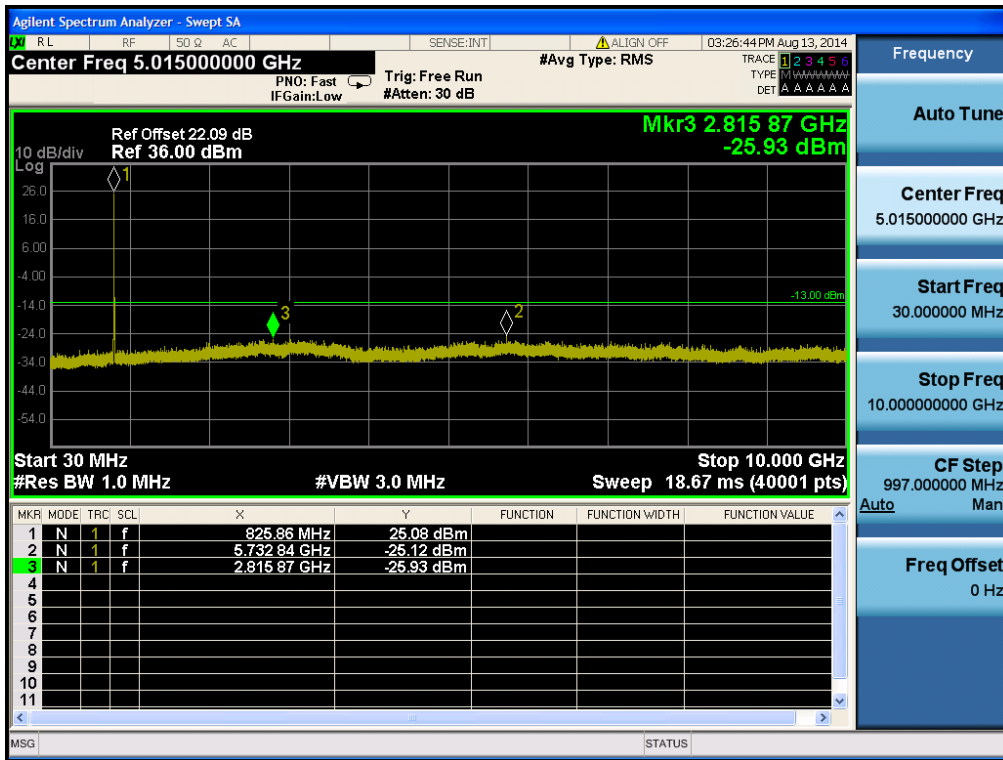

HSUPA850 & Channel: 4183

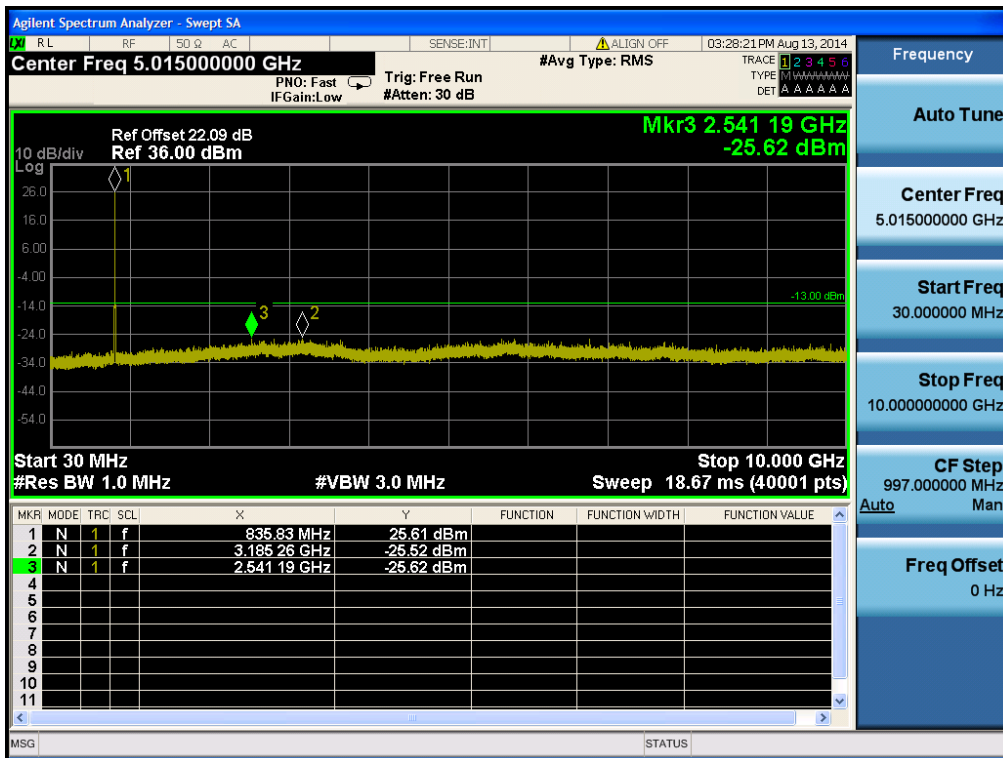

HSUPA850 & Channel: 4233

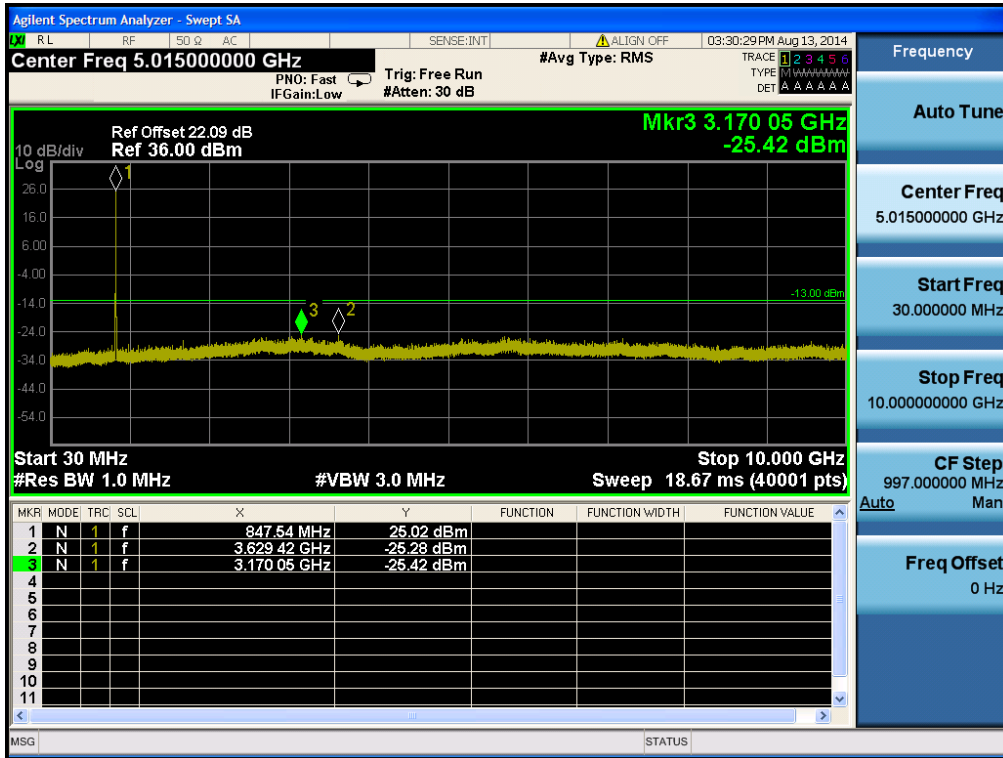

GSM1900 & Channel: 512

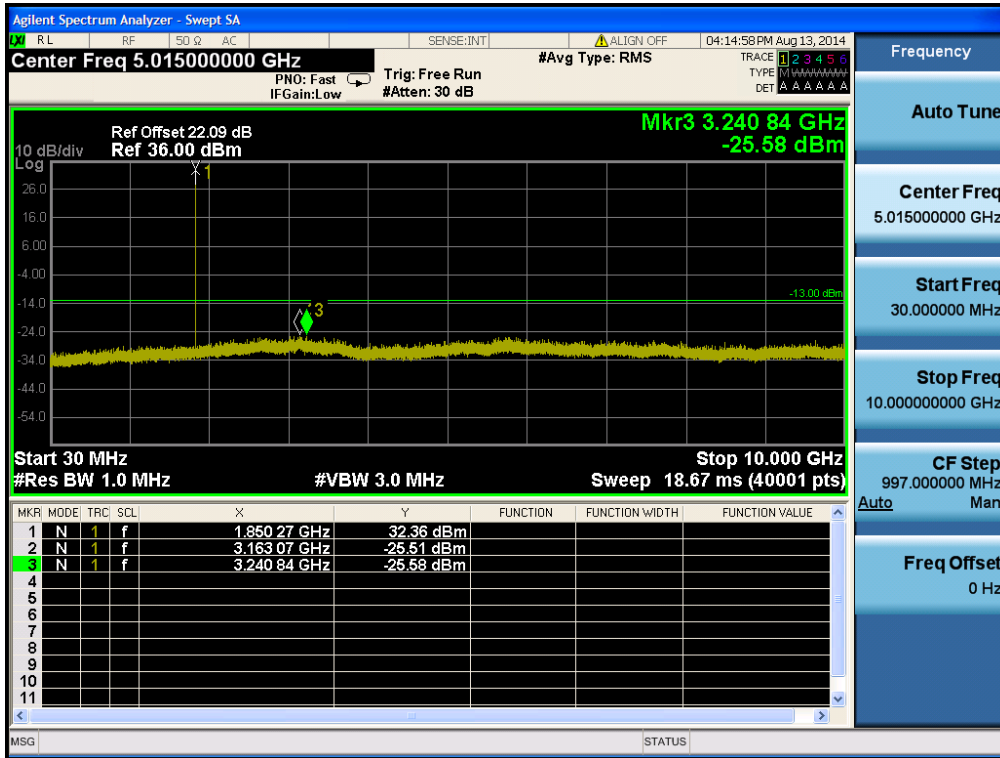

GSM1900 & Channel: 512

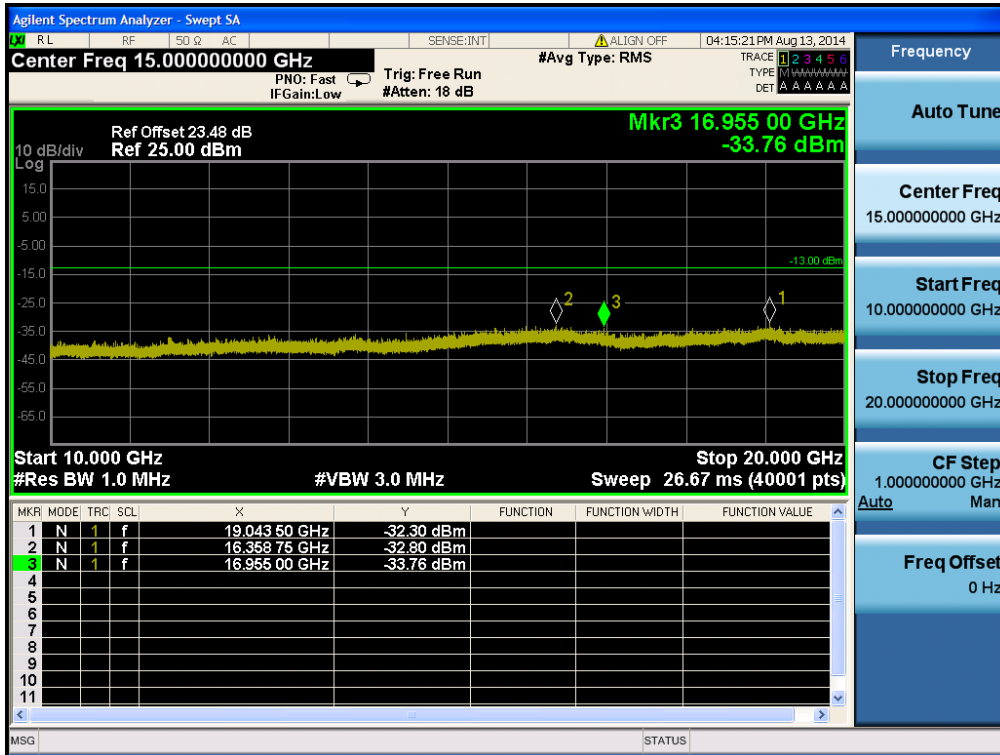

GSM1900 & Channel: 661

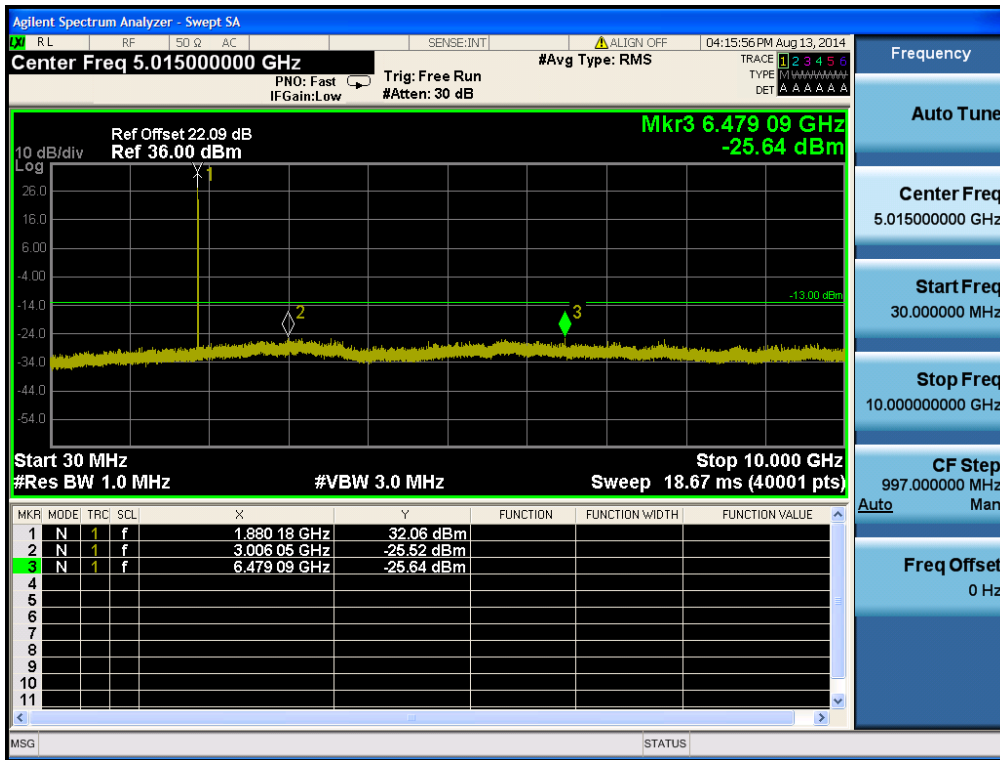

GSM1900 & Channel: 661

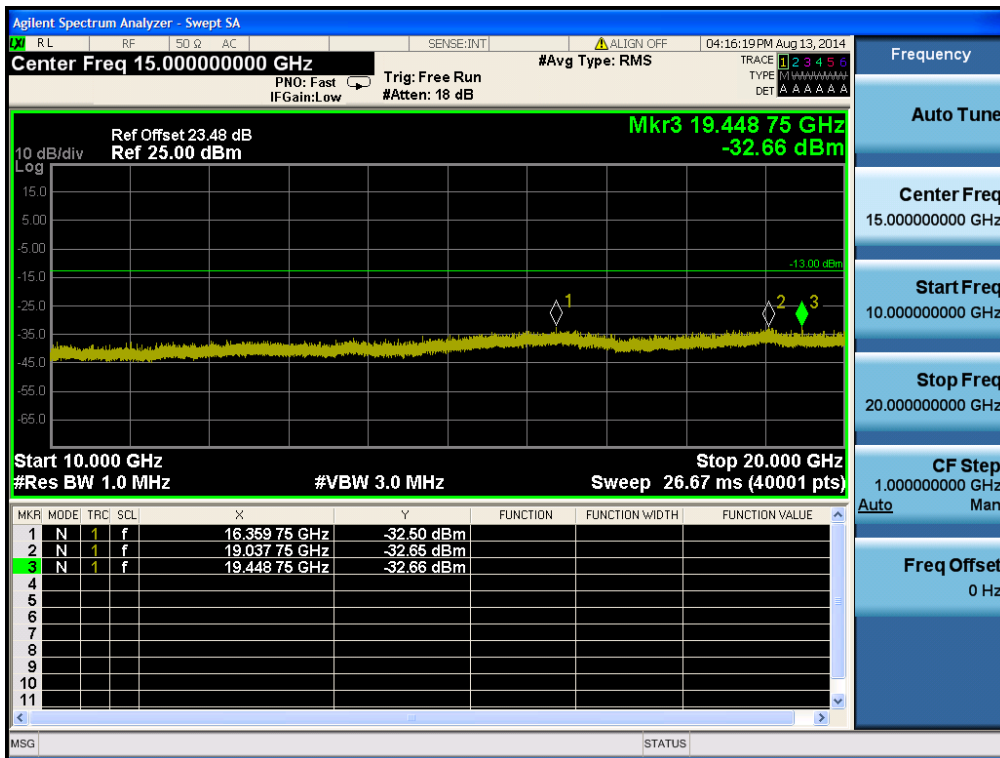

GSM1900 & Channel: 810

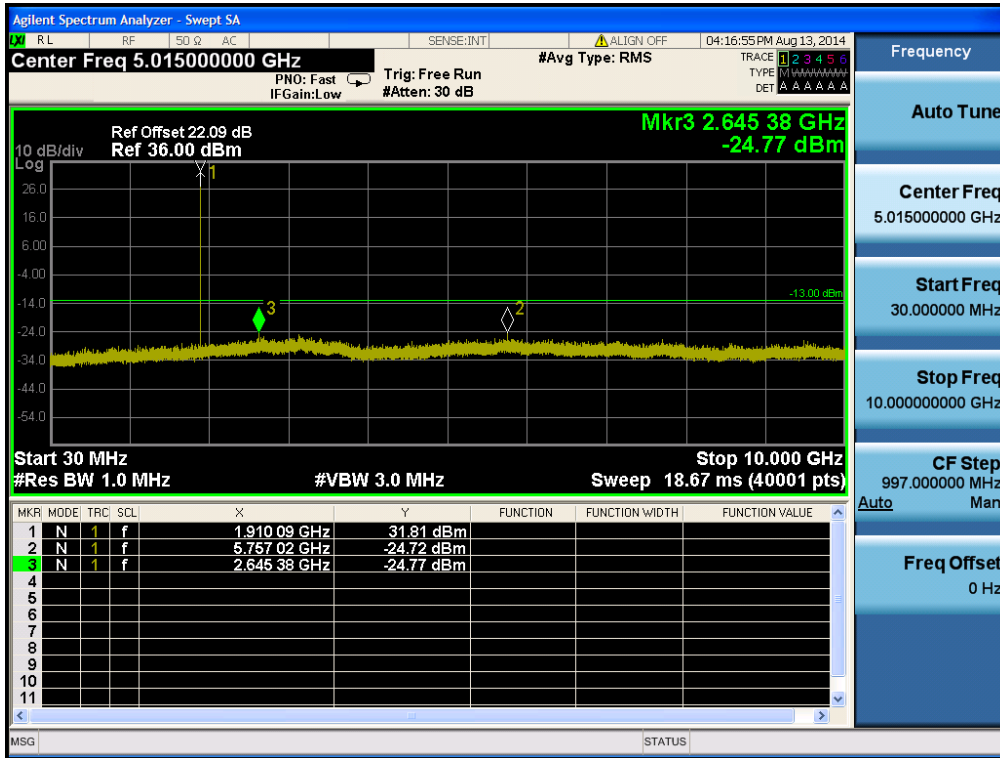

GSM1900 & Channel: 810

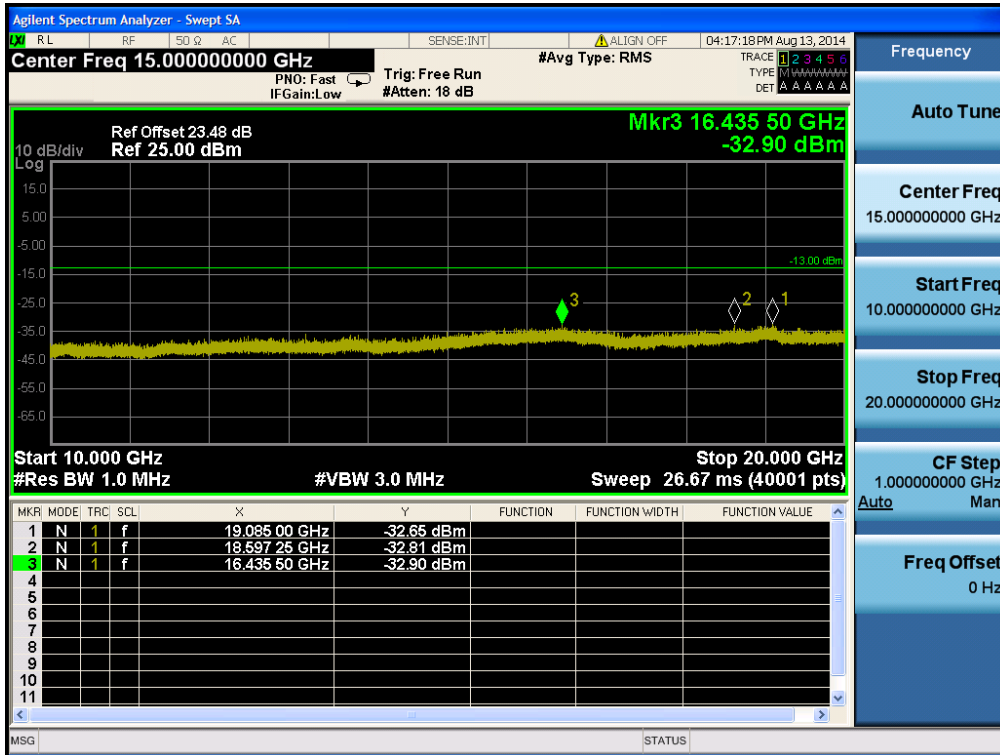

WCDMA1900 & Channel: 9262

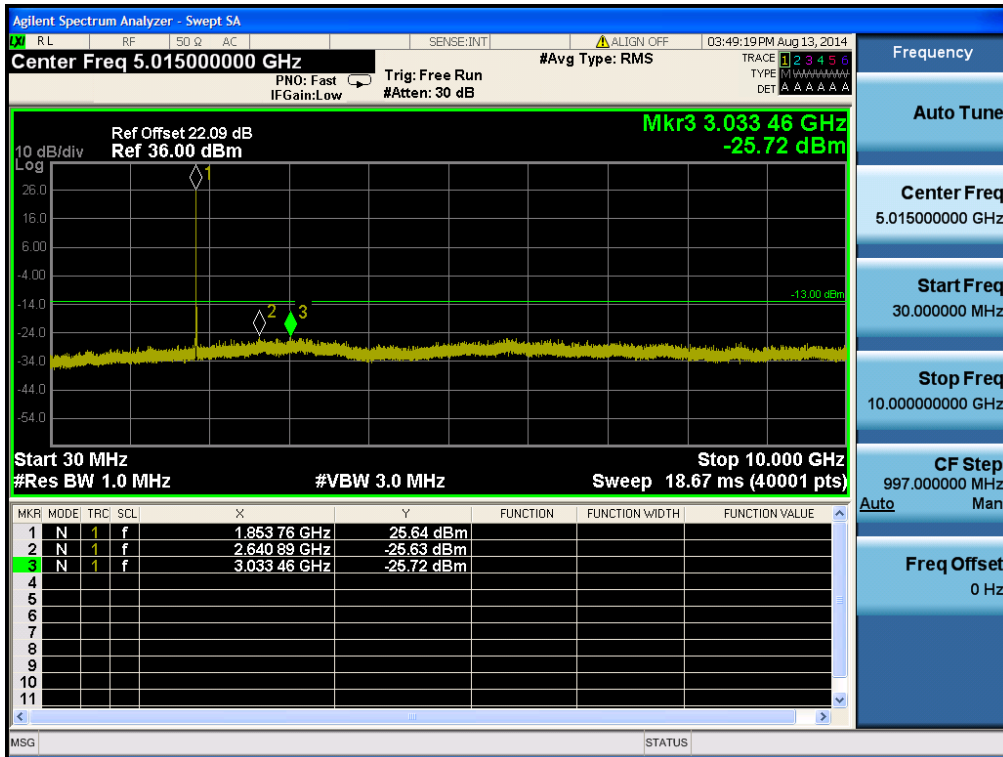

WCDMA1900 & Channel: 9262

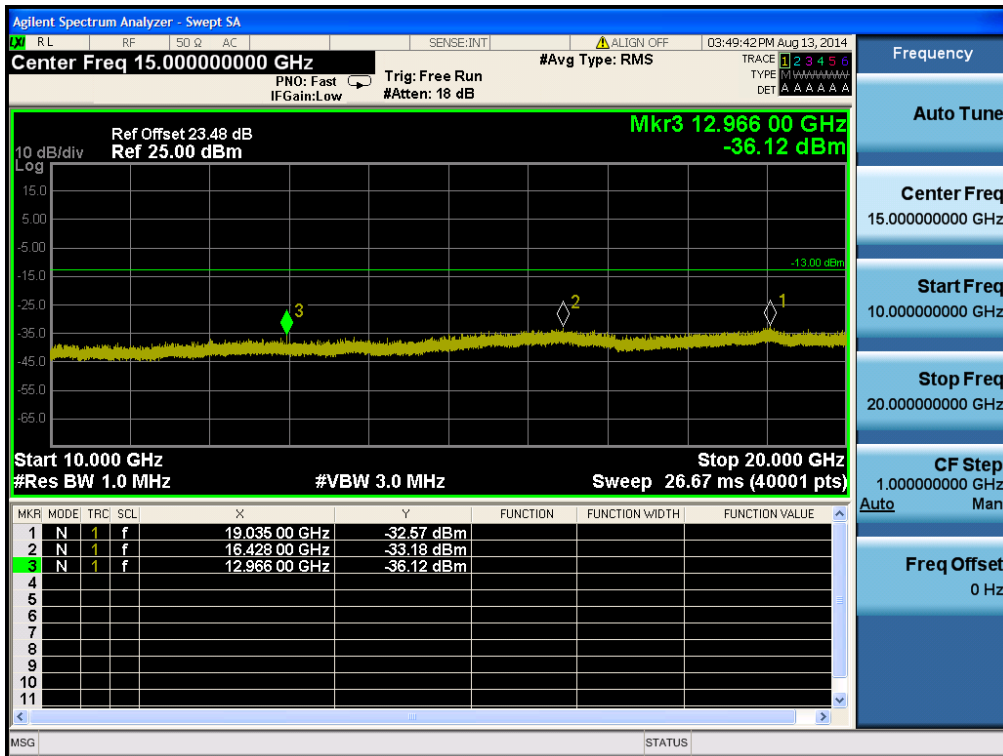

WCDMA1900 & Channel: 9400

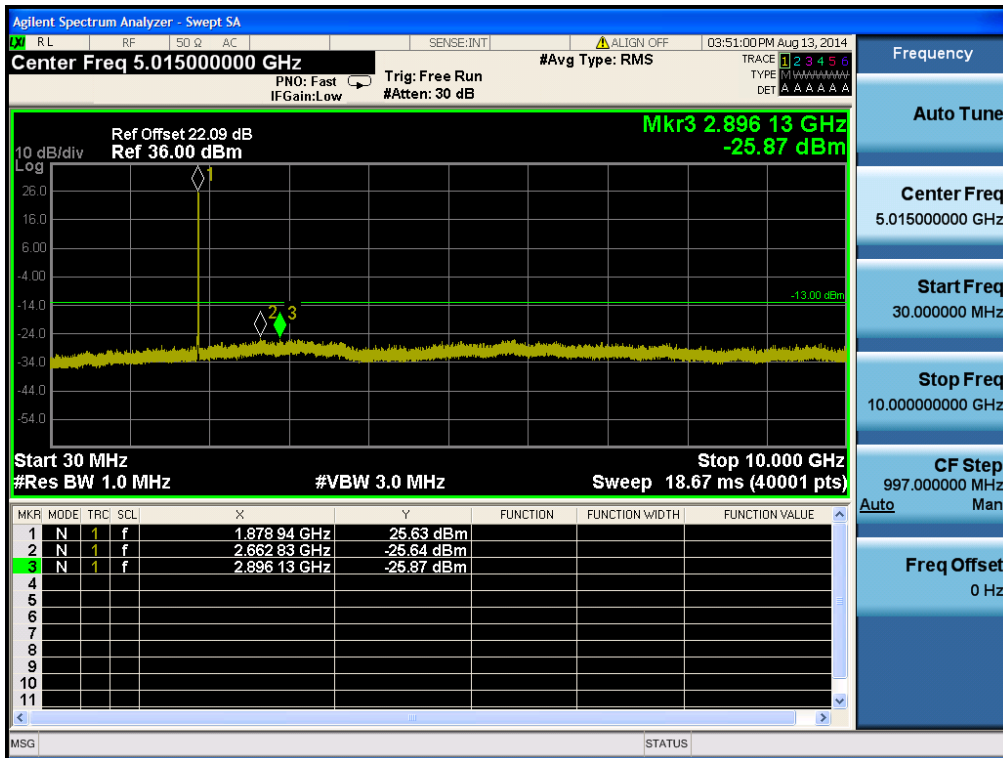

WCDMA1900 & Channel: 9400

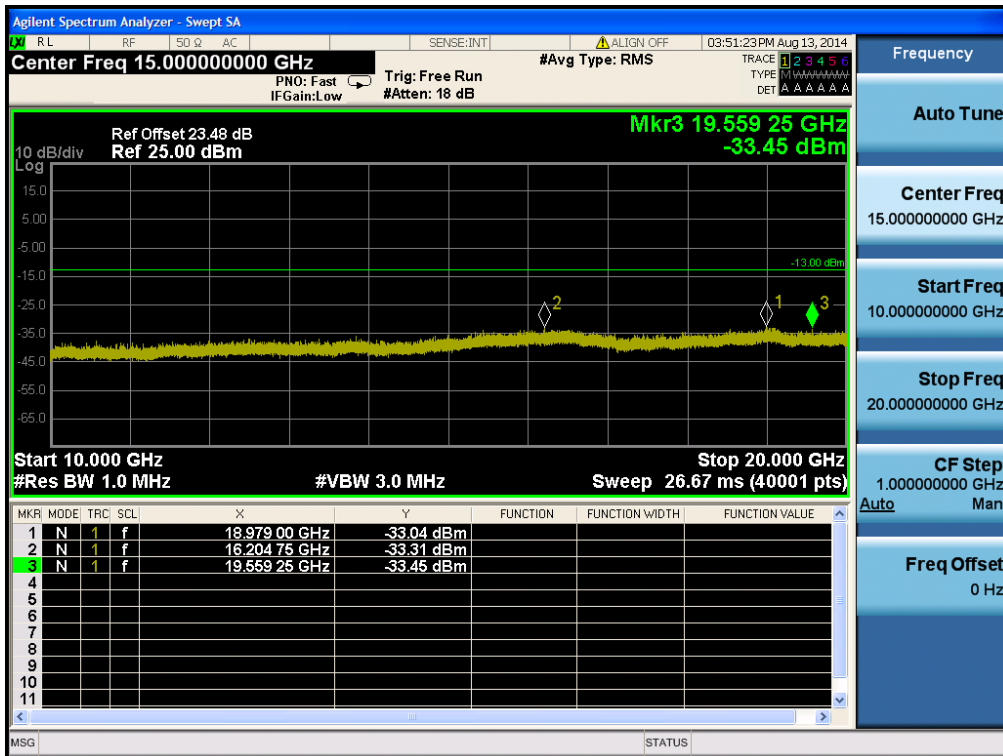

WCDMA1900 & Channel: 9538

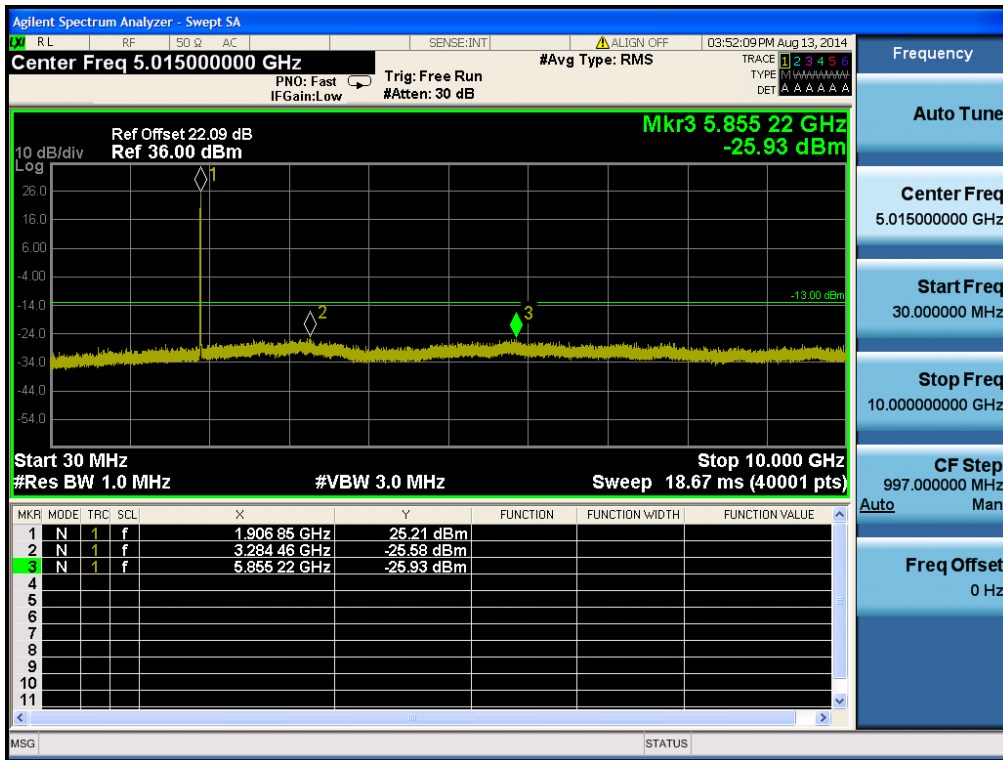

WCDMA1900 & Channel: 9538

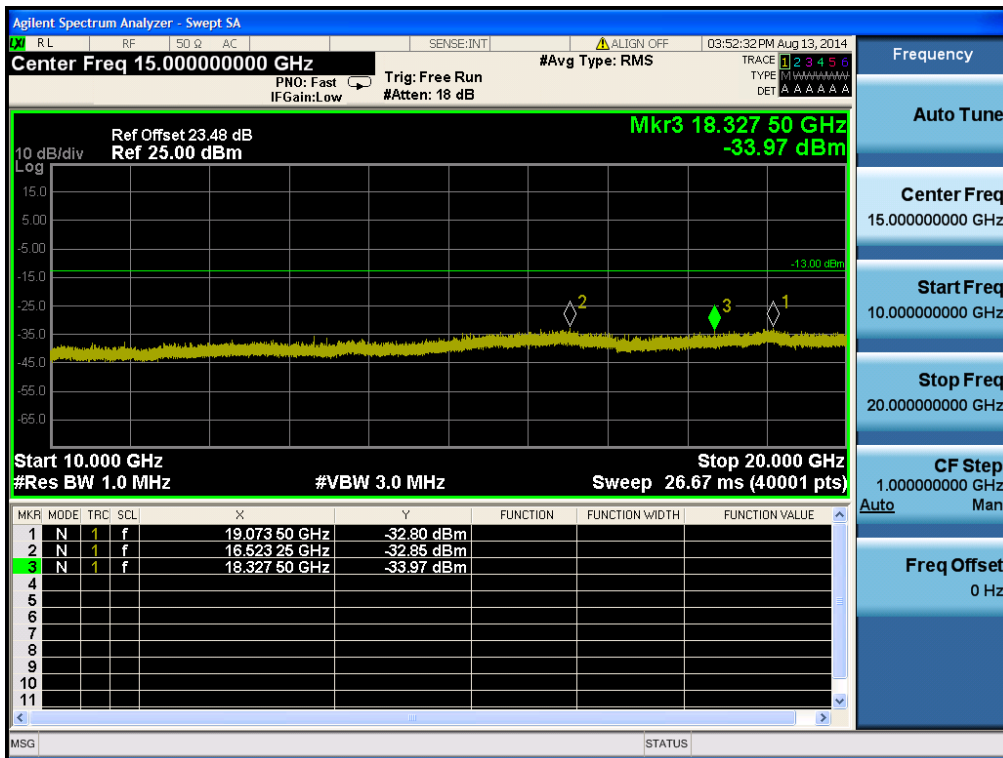

HSUPA1900 & Channel: 9262

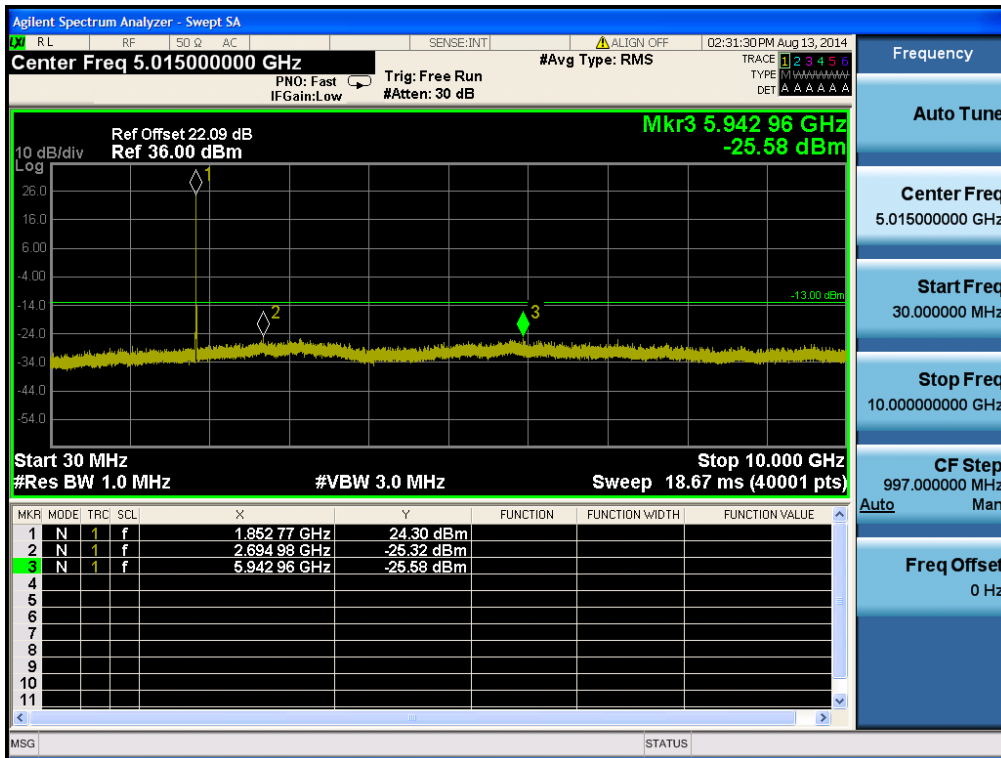

HSUPA 1900 & Channel: 9262

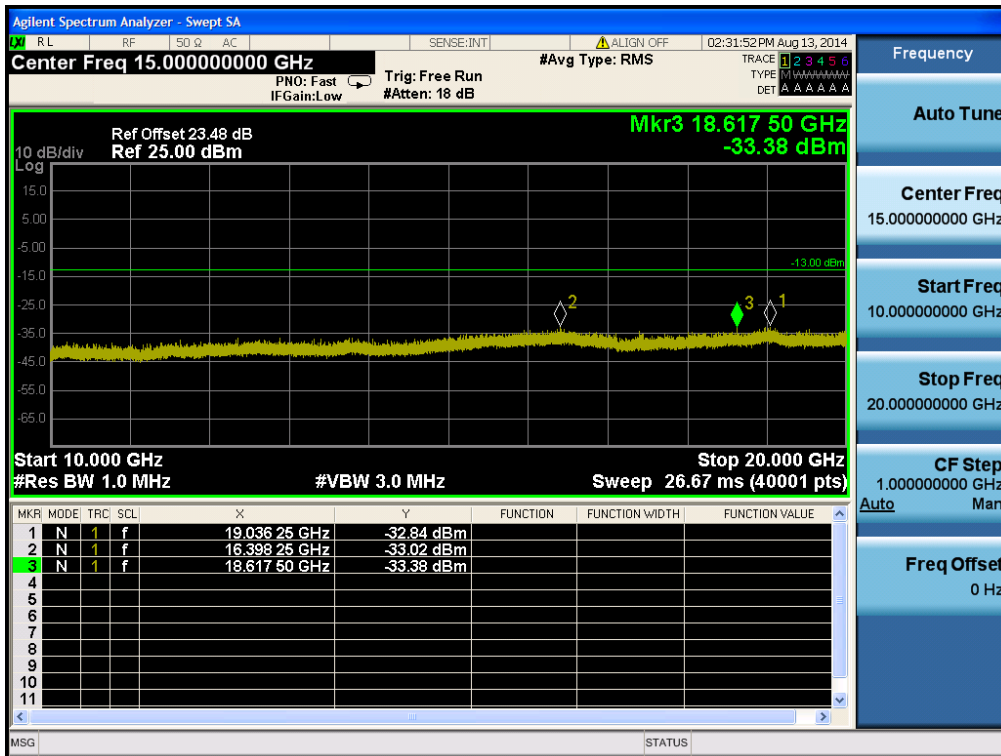

HSUPA1900 & Channel: 9400

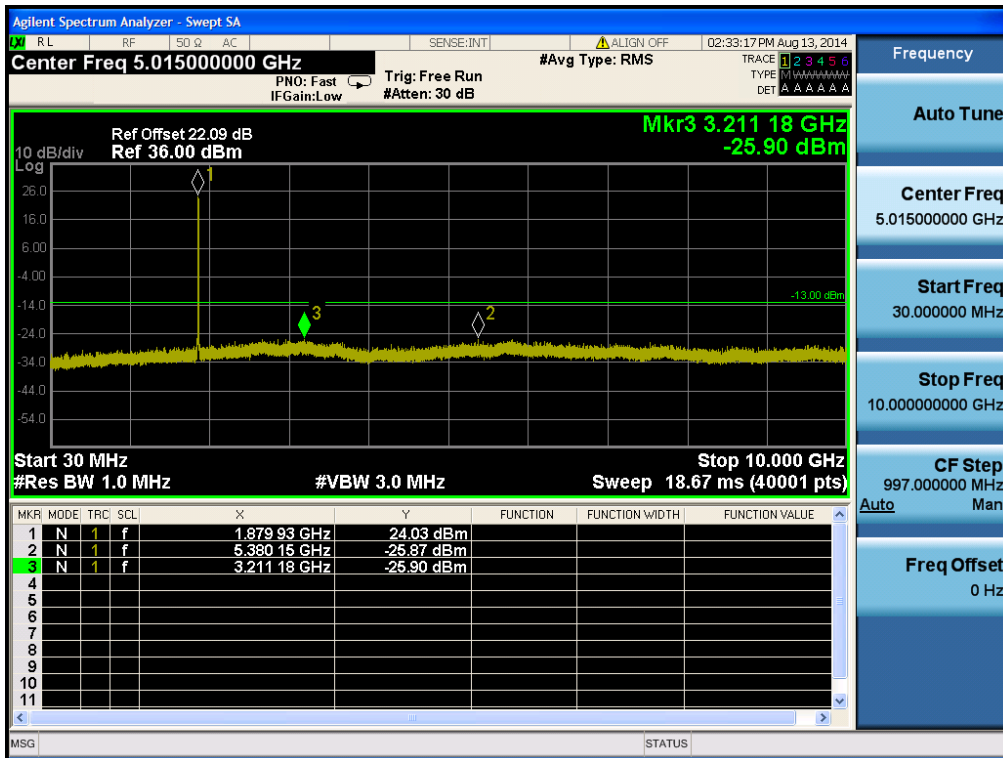

HSUPA1900 & Channel: 9400

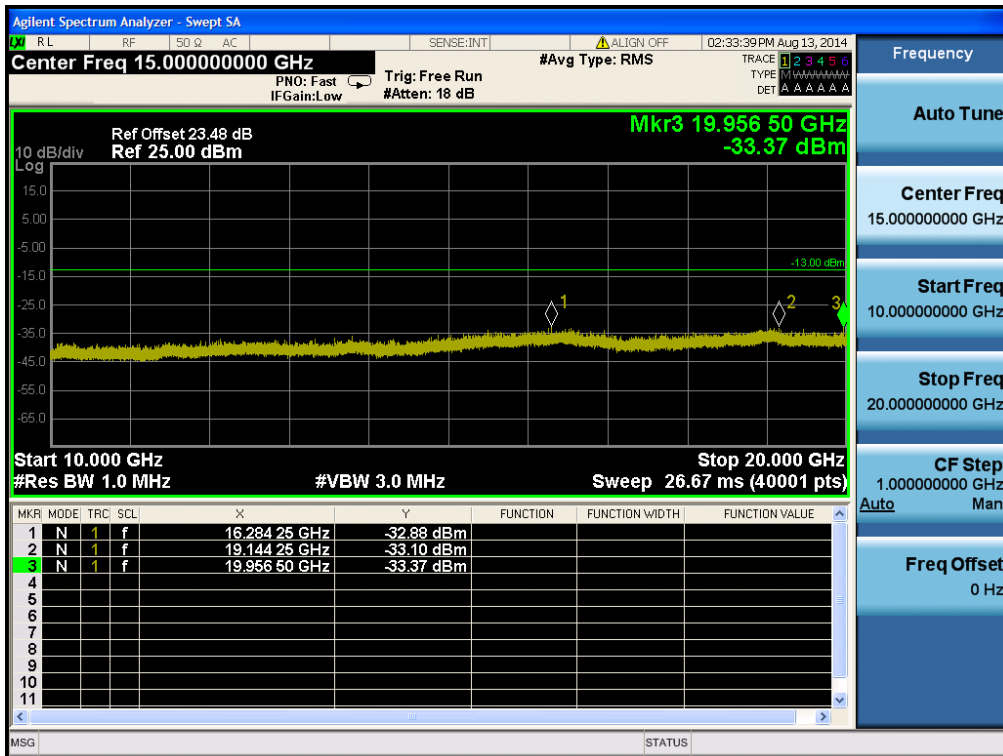

HSUPA1900 & Channel: 9538

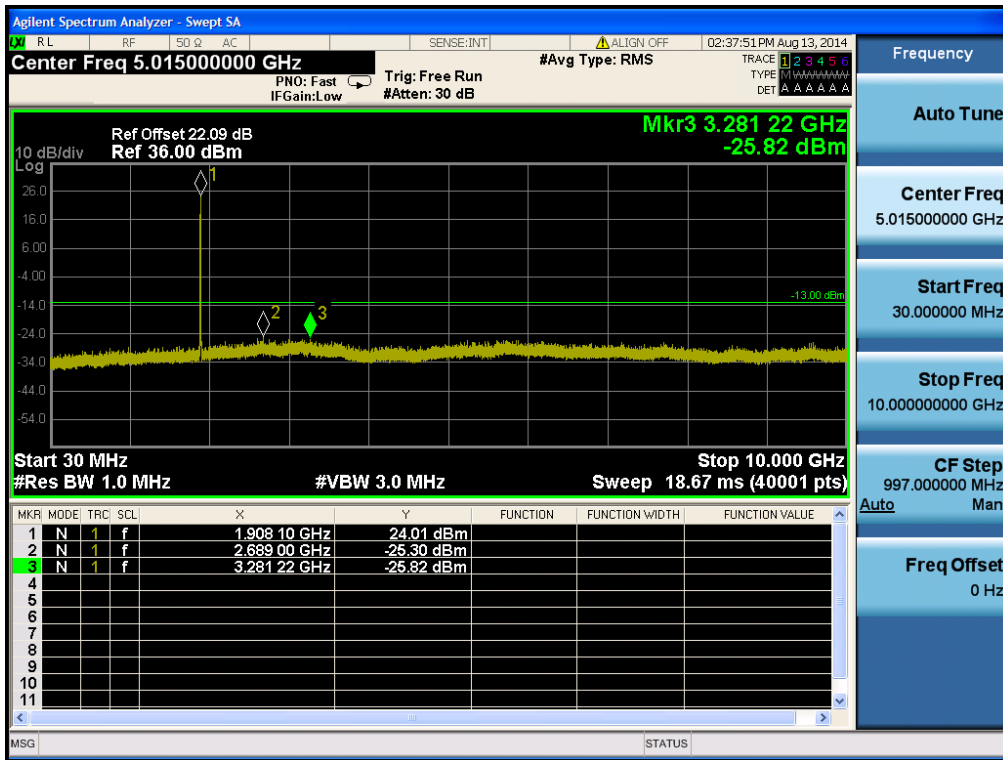

HSUPA1900 & Channel: 9538

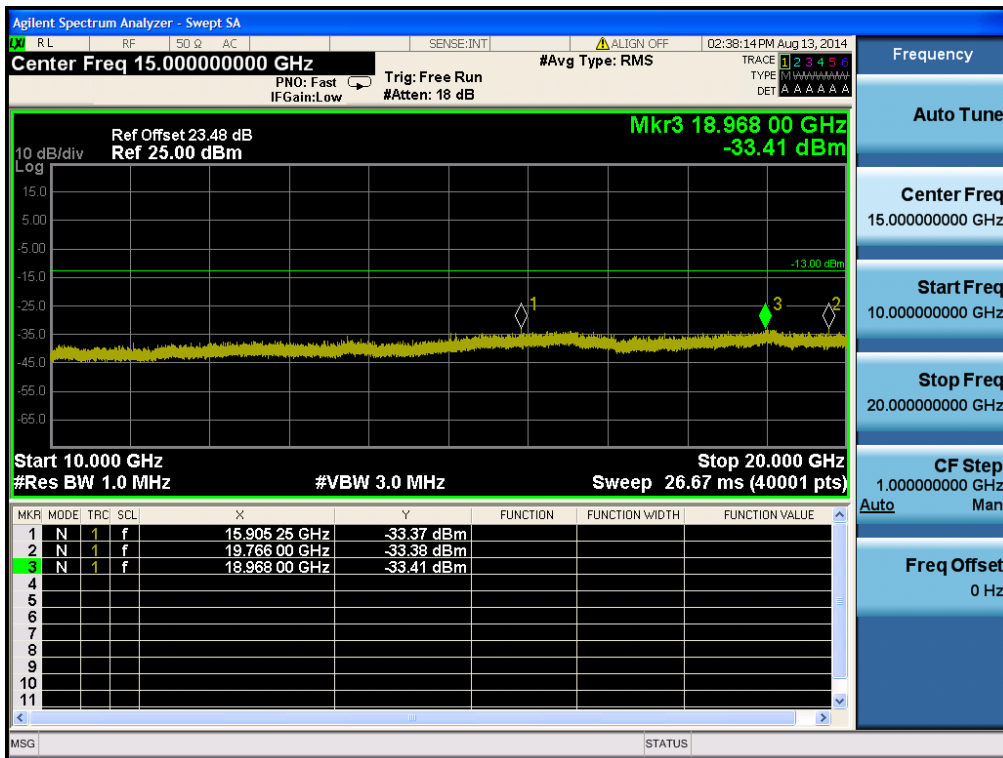

8.4 Band Edge

GSM850 & Channel: 128

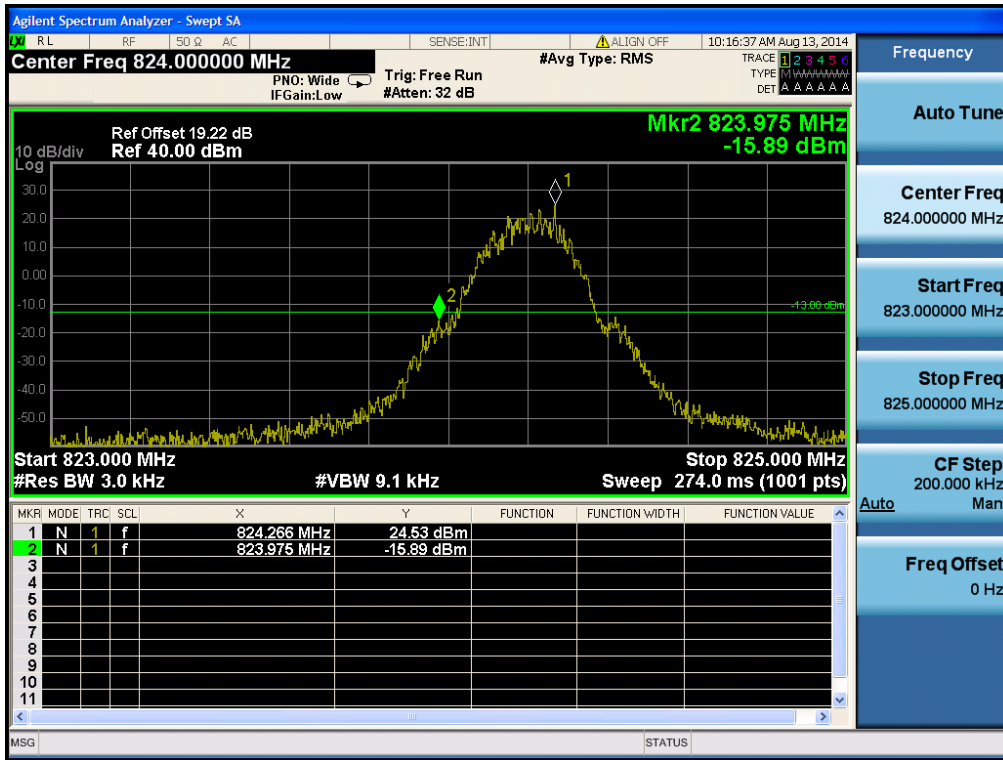

GSM850 & Channel: 251

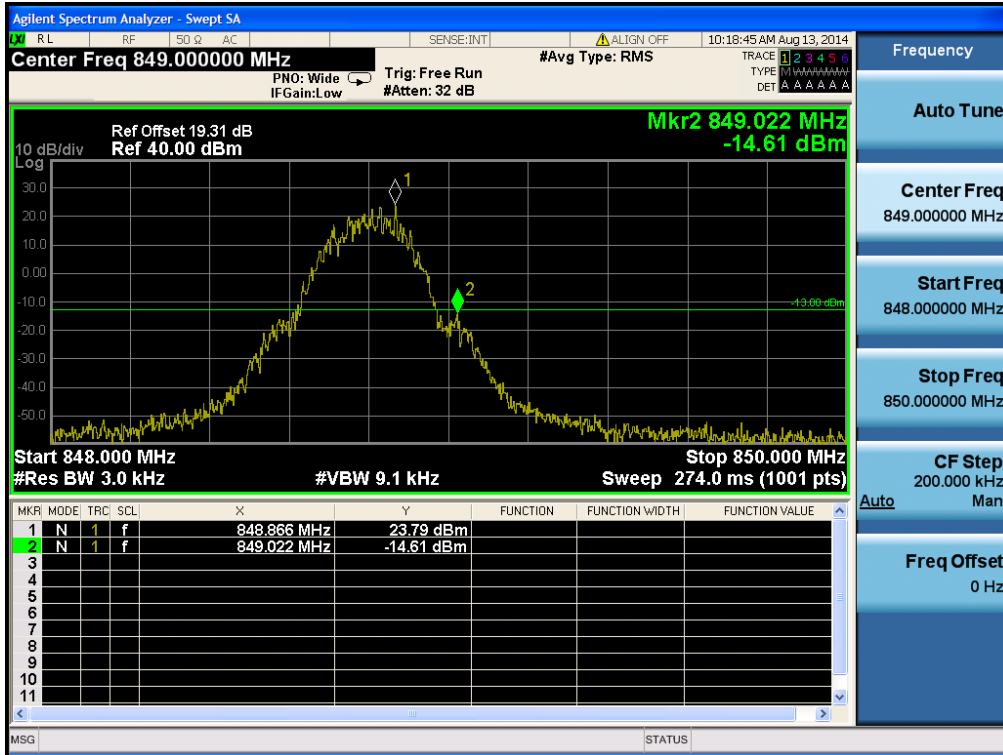

EDGE 850 & Channel: 128

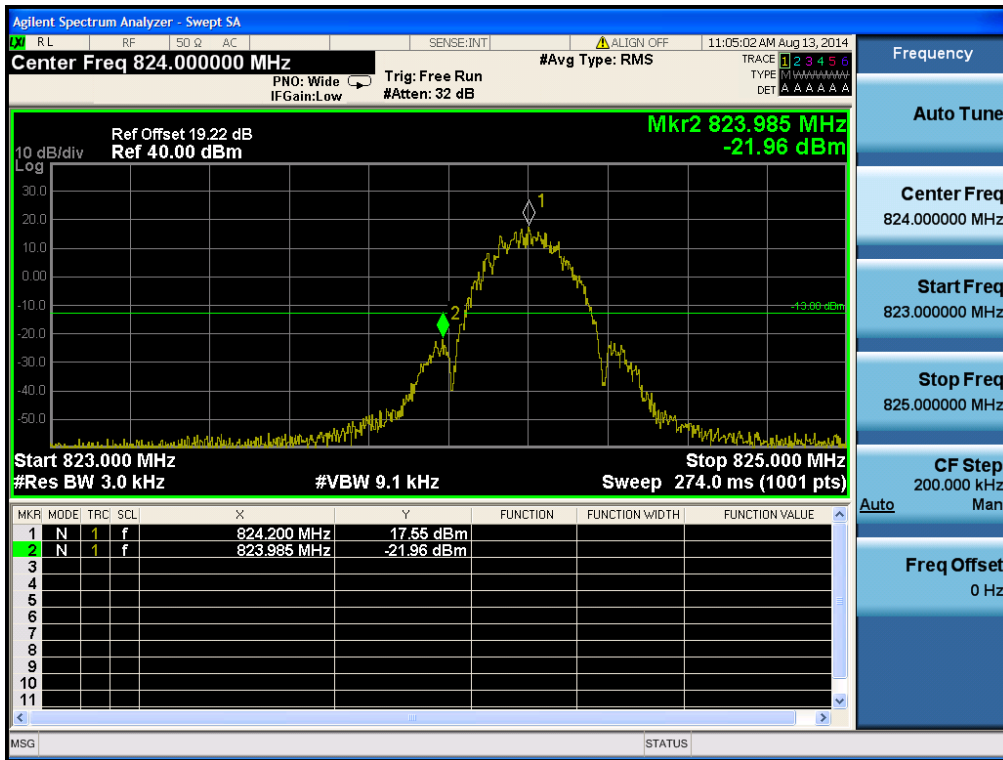

EDGE 850 & Channel: 251

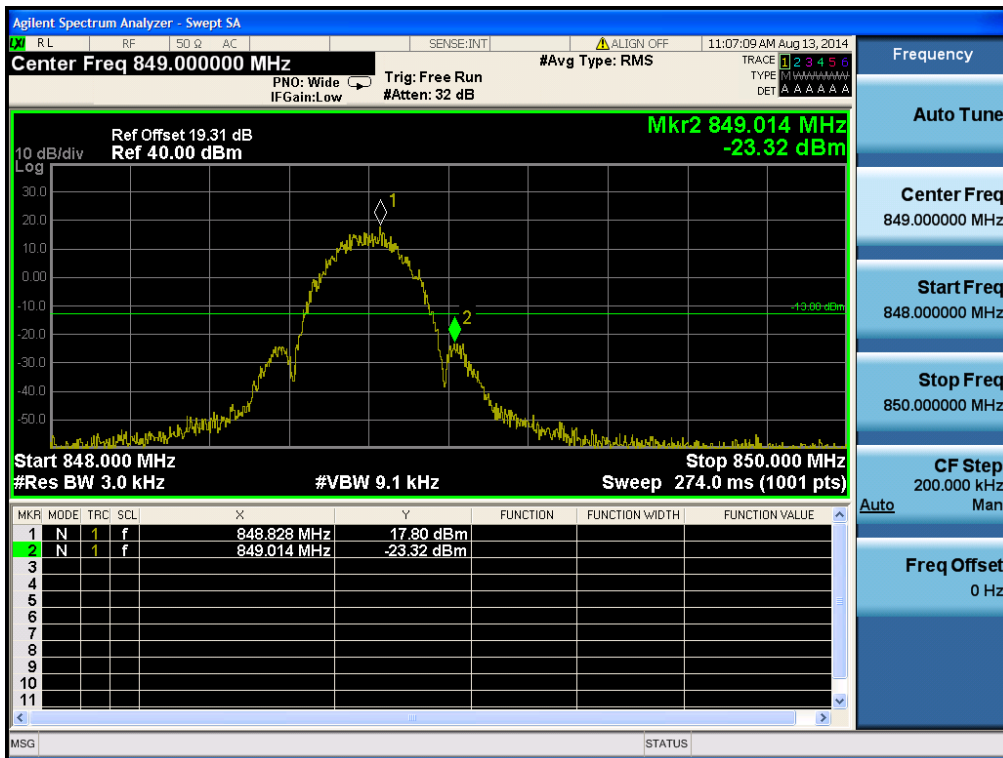

WCDMA850& Channel: 4132



WCDMA850& Channel: 4132

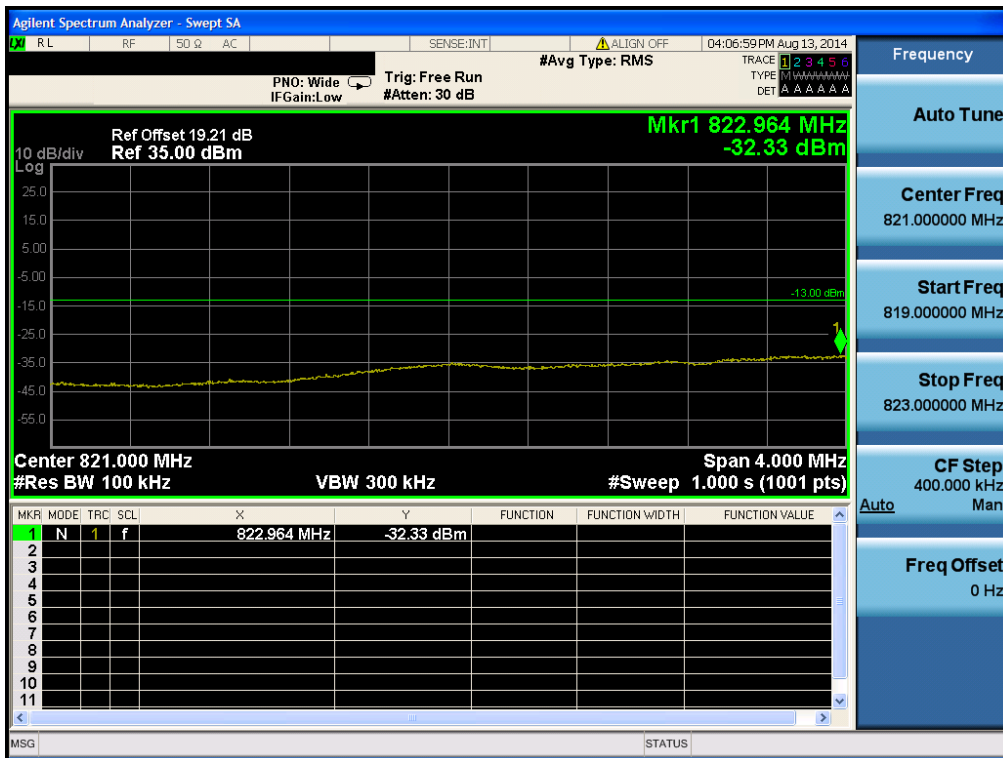

WCDMA850& Channel: 4233

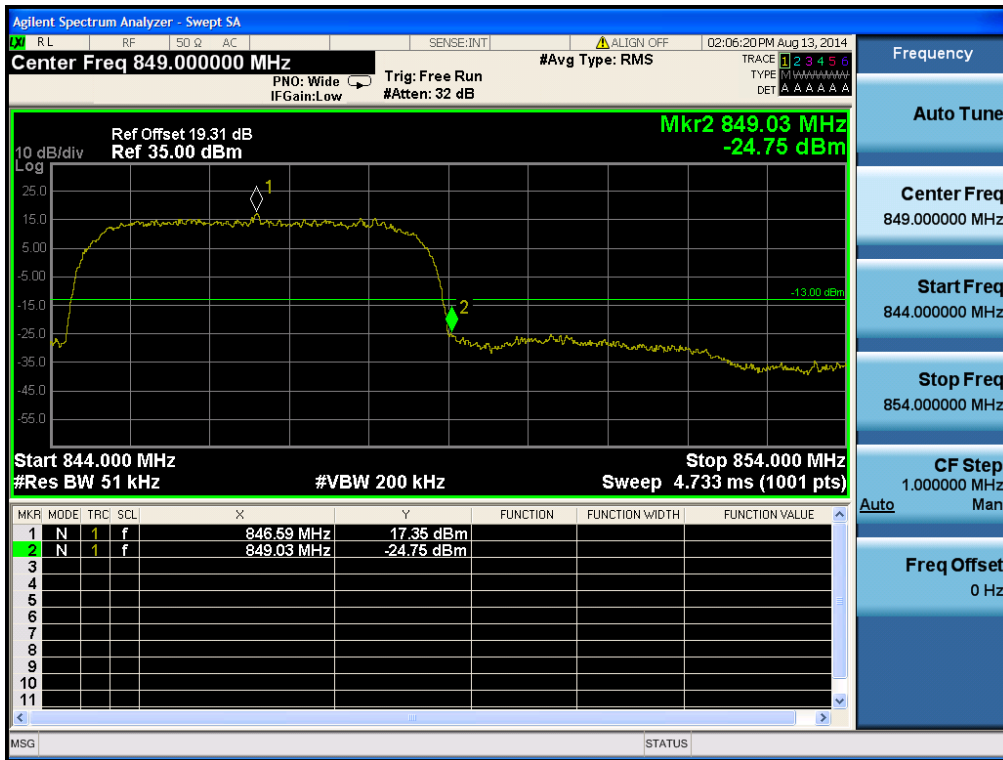

WCDMA850& Channel: 4233

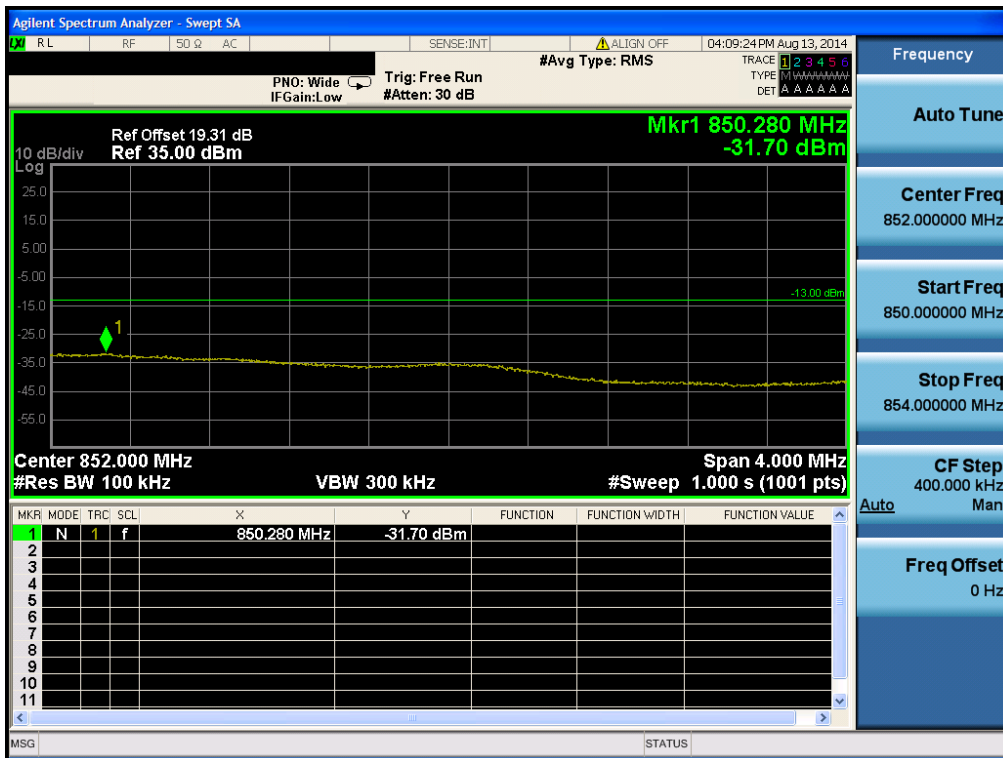

HSUPA850& Channel: 4132



HSUPA850 & Channel: 4132

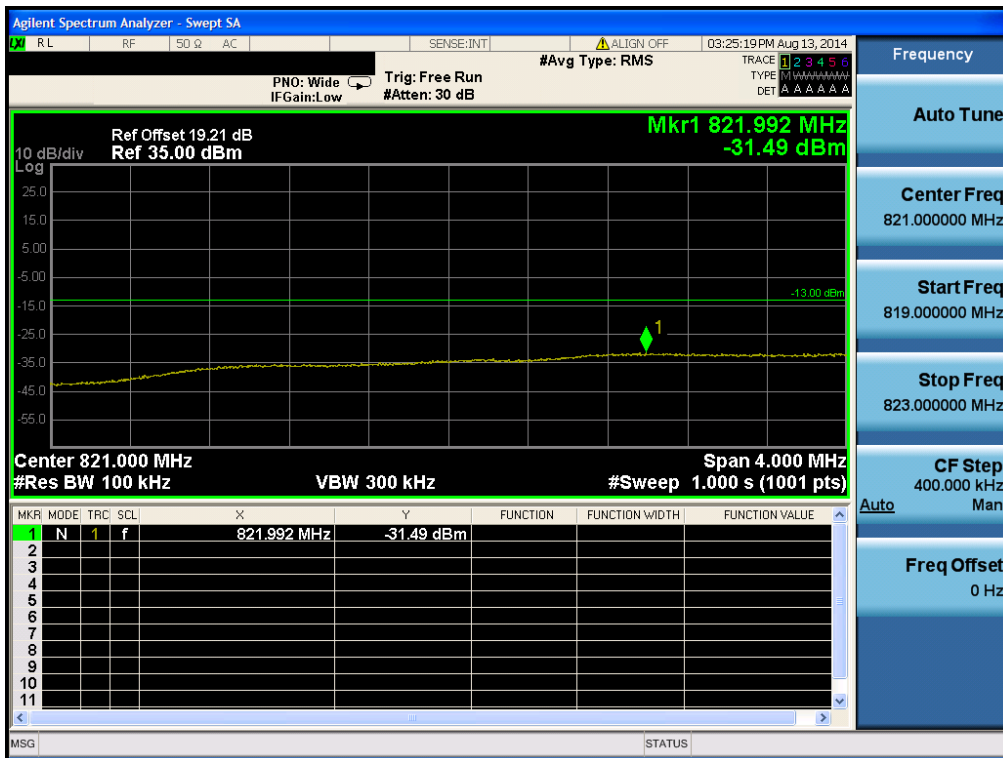

HSUPA850 & Channel: 4233



HSUPA850 & Channel: 4233

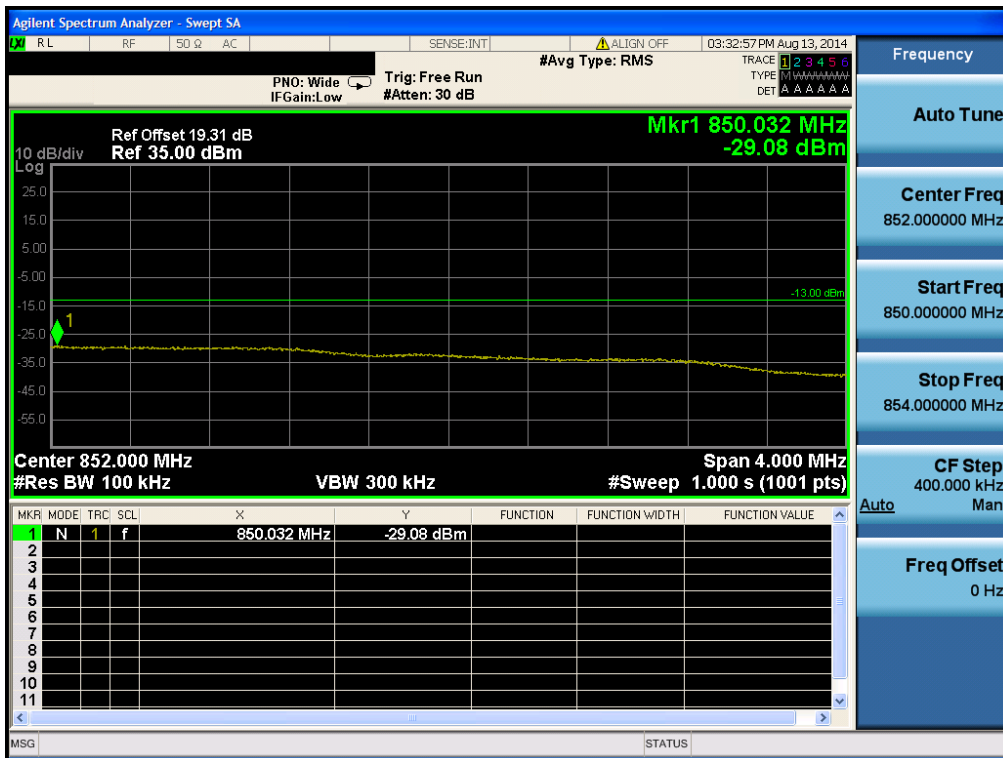

GSM1900 & Channel: 512

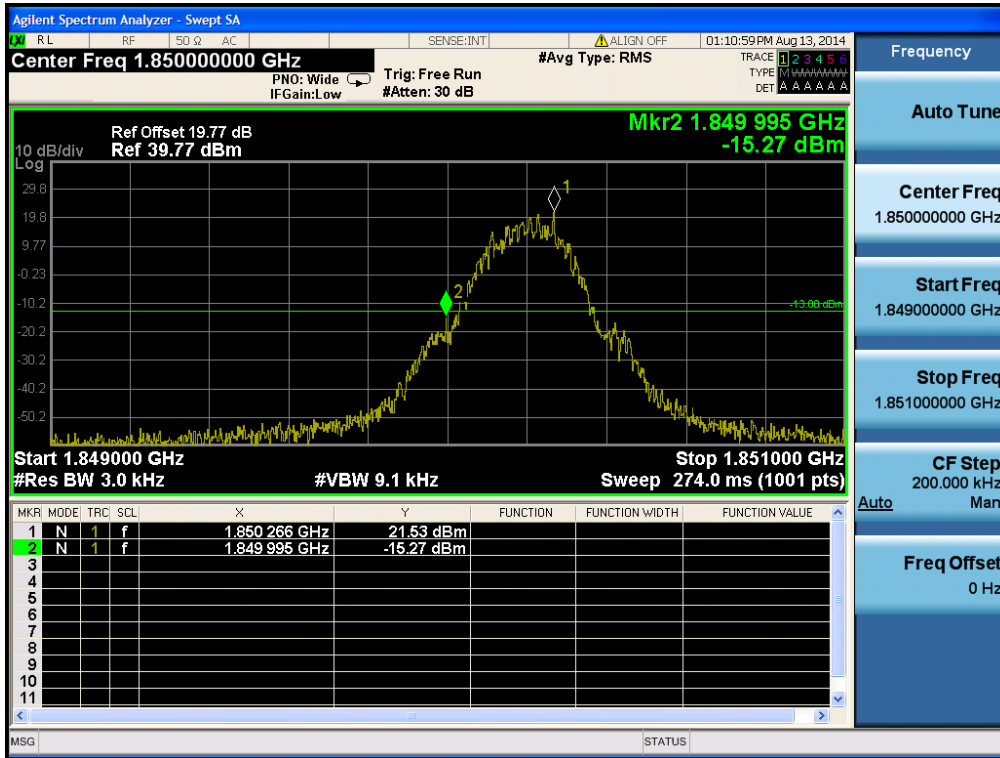

GSM1900 & Channel: 810

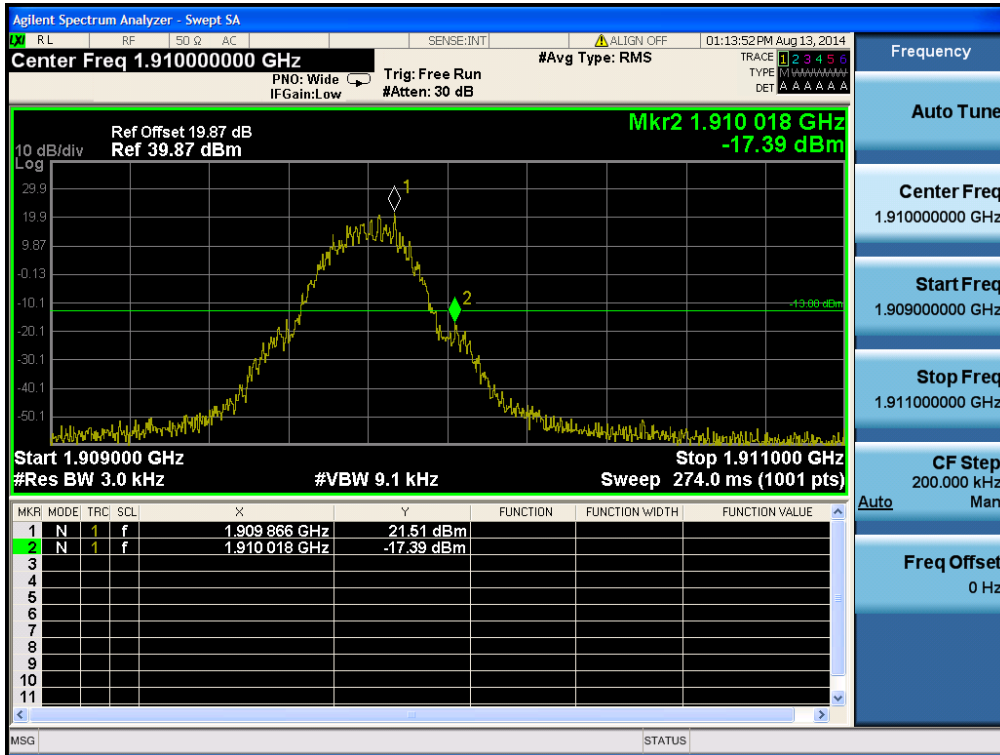

EDGE 1900 & Channel: 512

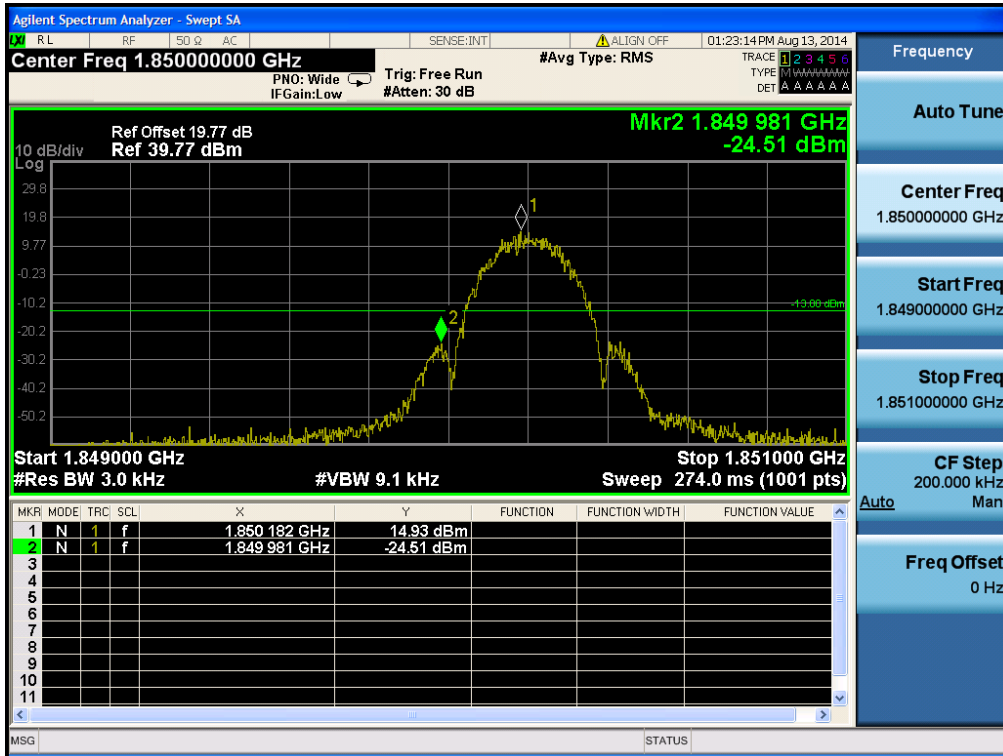

EDGE 1900 & Channel: 810

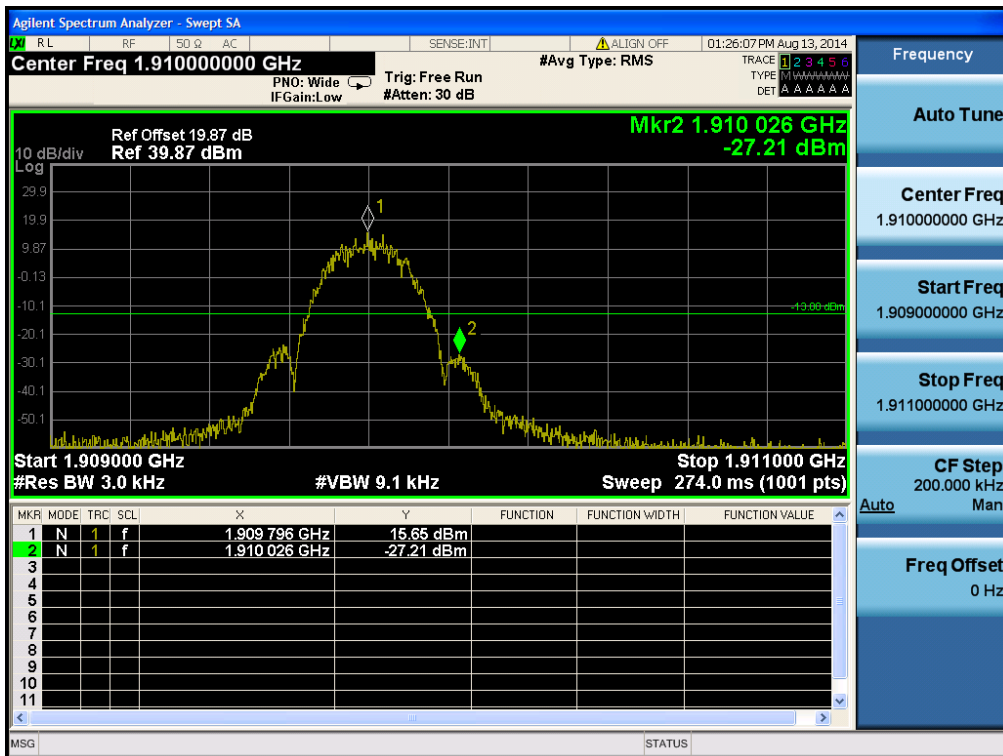

WCDMA1900 & Channel: 9538

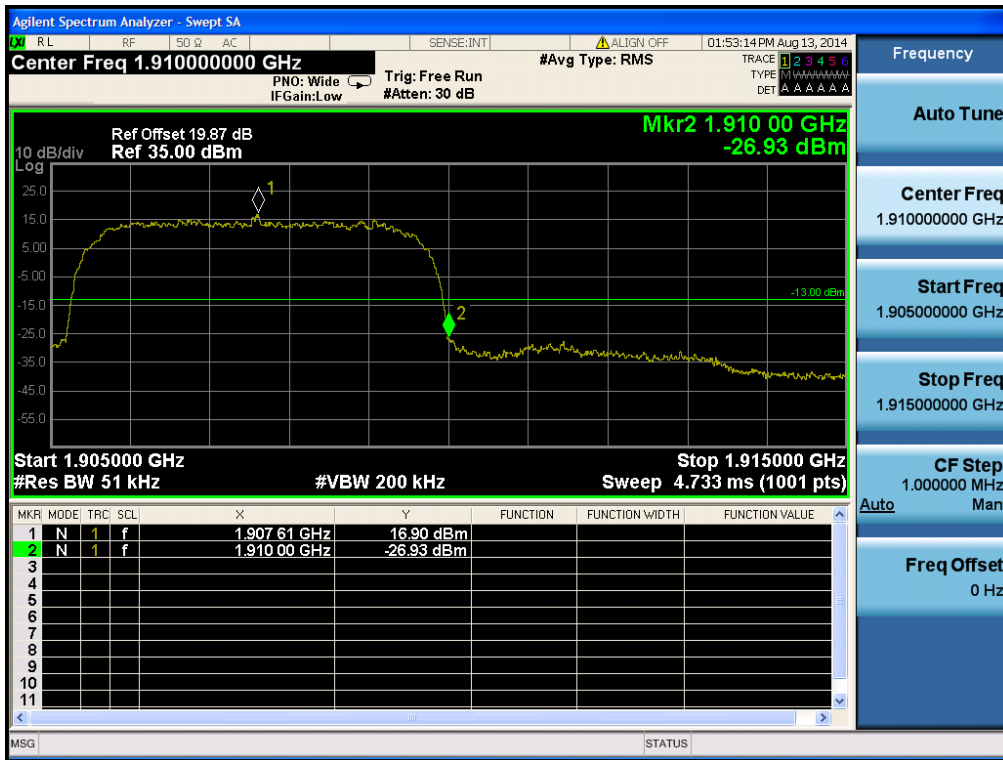

WCDMA1900 & Channel: 9538

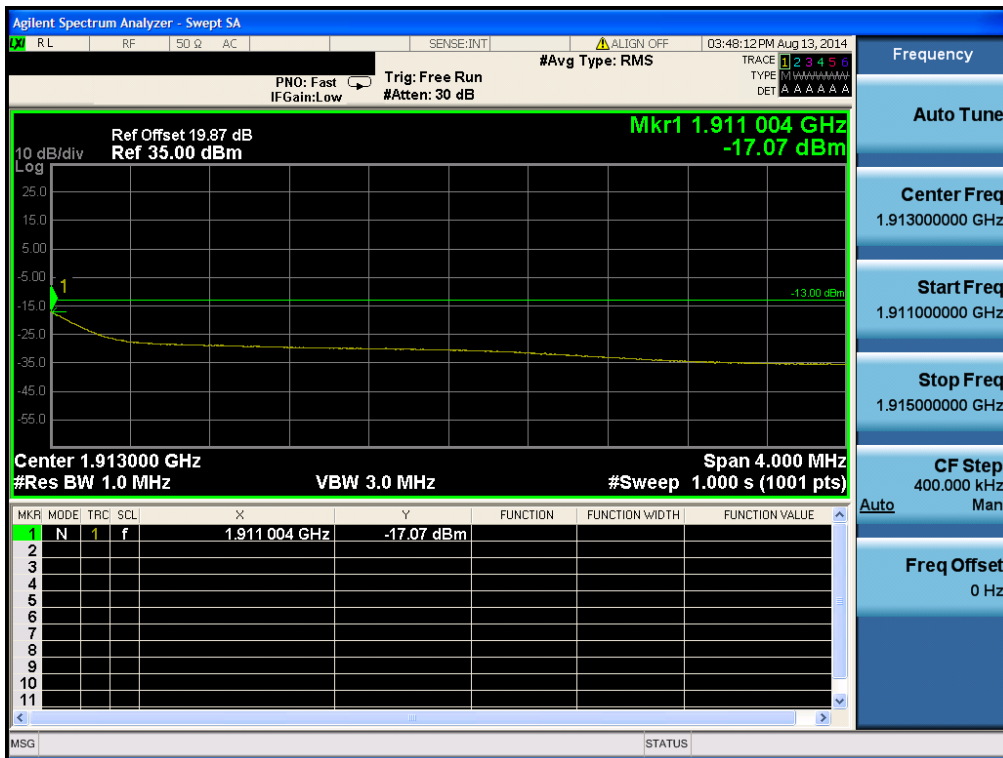

HSUPA1900 & Channel: 9262

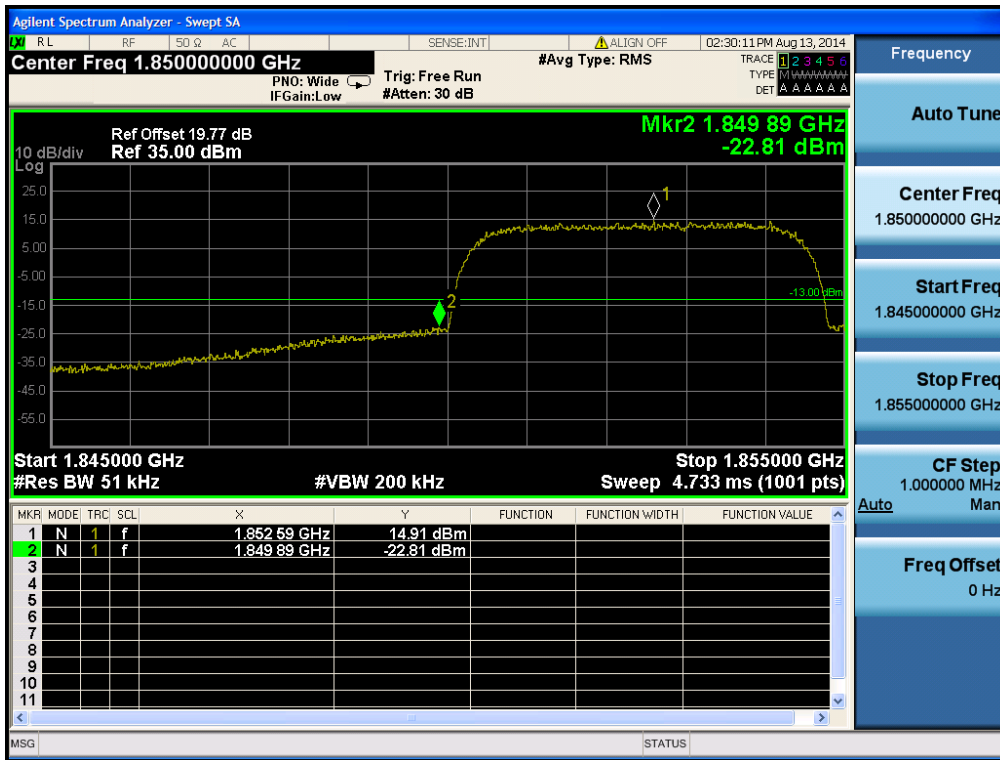

HSUPA1900 & Channel: 9262

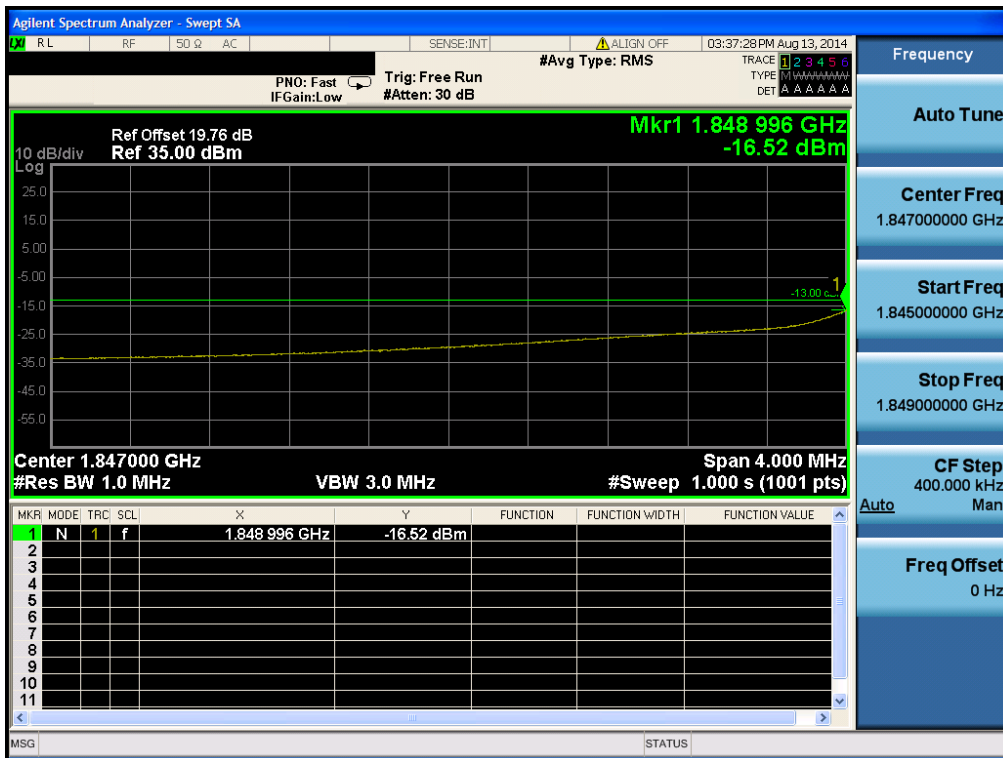

HSUPA1900 & Channel: 9538

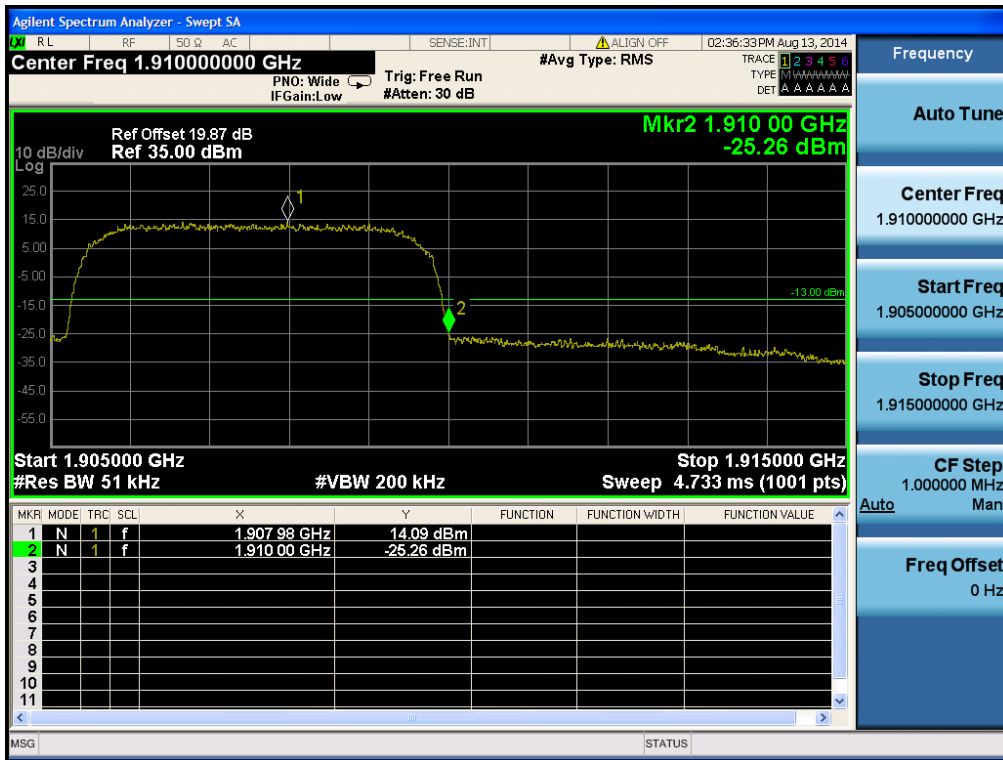

HSUPA1900 & Channel: 9538

