

HCT CO., LTD.

CERTIFICATE OF COMPLIANCE FCC Certification

Applicant Name:

LG Electronics MobileComm U.S.A., Inc.

Address:

1000 Sylvan Avenue, Englewood Cliffs NJ 07632

Date of Issue:

August 12, 2014

Test Site/Location:

HCT CO., LTD., 74, Seoicheon-ro 578beon-gil, Majang-myeon, Icheon-si, Gyeonggi-do, Korea

Report No.: HCT-R-1408-F009**HCT FRN:** 0005866421**FCC ID:****ZNFD390N****APPLICANT:****LG Electronics MobileComm U.S.A., Inc.****FCC Model(s):**

LG-D390n

EUT Type:

GSM/WCDMA/LTE phone with Bluetooth/WLAN/NFC

FCC Classification:

Licensed Portable Transmitter Held to Ear (PCE)

FCC Rule Part(s):

§2 , §27

Tx Frequency:706.5 MHz – 713.5 MHz (LTE – Band 17),
1710.7 MHz – 1754.3 MHz (LTE – Band 4)**Max. RF Output Power:**

Band 17 (5 MHz) :	0.104 W (QPSK) (20.16 dBm)
	0.102 W (16-QAM) (20.09 dBm)
Band 17 (10 MHz) :	0.104 W (QPSK) (20.17 dBm)
	0.108 W (16-QAM) (20.34 dBm)
Band 4 (1.4 MHz):	0.522 W (QPSK) (27.18 dBm)
	0.574 W (16-QAM) (27.59 dBm)
Band 4 (3 MHz):	0.540 W (QPSK) (27.32 dBm)
	0.564 W (16-QAM) (27.51 dBm)
Band 4 (5 MHz):	0.514 W (QPSK) (27.11 dBm)
	0.577 W (16-QAM) (27.61 dBm)
Band 4 (10 MHz):	0.542 W (QPSK) (27.34 dBm)
	0.570 W (16-QAM) (27.56 dBm)
Band 4 (15 MHz):	0.551 W (QPSK) (27.41 dBm)
	0.526 W (16-QAM) (27.21 dBm)
Band 4 (20 MHz):	0.467 W (QPSK) (26.69 dBm)
	0.604 W (16-QAM) (27.81 dBm)
Emission Designator(s):	Band 17 (5 MHz) : 4M50G7D (QPSK) / 4M49W7D (16-QAM)
	Band 17 (10 MHz) : 8M98G7D (QPSK) / 8M94W7D (16-QAM)
	Band 4 (1.3 MHz) : 1M10G7D (QPSK) / 1M09W7D (16-QAM)
	Band 4 (4 MHz) : 2M70G7D (QPSK) / 2M70W7D (16-QAM)
	Band 4 (5 MHz) : 4M49G7D (QPSK) / 4M49W7D (16-QAM)
	Band 4 (10 MHz) : 9M00G7D (QPSK) / 8M94W7D (16-QAM)
	Band 4 (15 MHz) : 13M4G7D (QPSK) / 13M4W7D (16-QAM)
	Band 4 (20 MHz) : 17M8G7D (QPSK) / 17M9W7D (16-QAM)

Emission Designator(s):

The measurements shown in this report were made in accordance with the procedures specified in §2.947. I assume full responsibility for the accuracy and completeness of these measurements, and for the qualifications of all persons taking them.

HCT CO., LTD. Certifies that no party to this application has subject to a denial of Federal benefits that includes FCC benefits pursuant to section 5301 of the Anti-Drug Abuse Act of 1998,21 U.S. C.853(a)



Report prepared by
: Jong Seok Lee

Test engineer of RF Team



Approved by
: Chang Seok Choi

Manager of RF Team

This report only responds to the tested sample and may not be reproduced, except in full, without written approval of the HCT Co., Ltd.

Version

TEST REPORT NO.	DATE	DESCRIPTION
HCT-R-1408-F009	August 12, 2014	- First Approval Report

Table of Contents

1. GENERAL INFORMATION	4
2. INTRODUCTION	5
2.1. EUT DESCRIPTION.....	5
2.2. MEASURING INSTRUMENT CALIBRATION.....	5
2.3. TEST FACILITY	5
3. DESCRIPTION OF TESTS.....	6
3.1 CONDUCTED OUTPUT POWER	6
3.2 ERP/EIRP RADIATED POWER AND RADIATED SPURIOUS EMISSIONS.....	7
3.3 PEAK-AVERAGE RATIO.	8
3.4 OCCUPIED BANDWIDTH.	10
3.5 BLOCK B FREQUENCY RANGE (704 – 710 and 734 – 740 MHz, 777 – 792 MHz)	11
3.6 AWS – MOBILE FREQUENCY BLOCKS (1710 – 1755 MHz).....	11
3.7 SPURIOUS AND HARMONIC EMISSIONS AT ANTENNA TERMINAL.....	12
3.8 FREQUENCY STABILITY / VARIATION OF AMBIENT TEMPERATURE	13
4. LIST OF TEST EQUIPMENT	14
5. SUMMARY OF TEST RESULTS	15
6. SAMPLE CALCULATION	16
7. TEST DATA	17
7.1 EFFECTIVE RADIATED POWER OUTPUT	17
7.2 EQUIVALENT ISOTROPIC RADIATED POWER OUTPUT	19
7.3 RADIATED SPURIOUS EMISSIONS	23
7.3.1 RADIATED SPURIOUS EMISSIONS (Band 17).....	23
7.3.2 RADIATED SPURIOUS EMISSIONS (Band 4).....	25
7.4 PEAK-TO-AVERAGE RATIO	31
7.5 OCCUPIED BANDWIDTH	32
7.6 CONDUCTED SPURIOUS EMISSIONS	33
7.6.1 BAND EDGE.....	34
7.7 FREQUENCY STABILITY / VARIATION OF AMBIENT TEMPERATURE	35
7.7.1 FREQUENCY STABILITY (LTE Band 17)	35
7.7.2 FREQUENCY STABILITY (LTE Band 4)	37
8. TEST PLOTS.....	43

MEASUREMENT REPORT

1. GENERAL INFORMATION

Applicant Name: LG Electronics MobileComm U.S.A., Inc.

Address: 1000 Sylvan Avenue, Englewood Cliffs NJ 07632

FCC ID: ZNFD390N

Application Type: Certification

FCC Classification: Licensed Portable Transmitter Held to Ear (PCE)

FCC Rule Part(s): §2 , §27

EUT Type: GSM/WCDMA/LTE phone with Bluetooth/WLAN/NFC

FCC Model(s): LG-D390n

Tx Frequency: 706.5 MHz – 713.5 MHz (LTE – Band 17),
1710.7 MHz – 1754.3 MHz (LTE – Band 4)

Max. RF Output Power:

Band 17 (5 MHz) :	0.104 W (QPSK) (20.16 dBm)
	0.102 W (16-QAM) (20.09 dBm)
Band 17 (10 MHz) :	0.104 W (QPSK) (20.17 dBm)
	0.108 W (16-QAM) (20.34 dBm)
Band 4 (1.4 MHz):	0.522 W (QPSK) (27.18 dBm)
	0.574 W (16-QAM) (27.59 dBm)
Band 4 (3 MHz):	0.540 W (QPSK) (27.32 dBm)
	0.564 W (16-QAM) (27.51 dBm)
Band 4 (5 MHz):	0.514 W (QPSK) (27.11 dBm)
	0.577 W (16-QAM) (27.61 dBm)
Band 4 (10 MHz):	0.542 W (QPSK) (27.34 dBm)
	0.570 W (16-QAM) (27.56 dBm)
Band 4 (15 MHz):	0.551 W (QPSK) (27.41 dBm)
	0.526 W (16-QAM) (27.21 dBm)
Band 4 (20 MHz):	0.467 W (QPSK) (26.69 dBm)
	0.604 W (16-QAM) (27.81 dBm)

Emission Designator(s):

Band 17 (5 MHz) :	4M50G7D (QPSK) / 4M49W7D (16-QAM)
Band 17 (10 MHz) :	8M98G7D (QPSK) / 8M94W7D (16-QAM)
Band 4 (1.3 MHz) :	1M10G7D (QPSK) / 1M09W7D (16-QAM)
Band 4 (4 MHz) :	2M70G7D (QPSK) / 2M70W7D (16-QAM)
Band 4 (5 MHz) :	4M49G7D (QPSK) / 4M49W7D (16-QAM)
Band 4 (10 MHz) :	9M00G7D (QPSK) / 8M94W7D (16-QAM)
Band 4 (15 MHz) :	13M4G7D (QPSK) / 13M4W7D (16-QAM)
Band 4 (20 MHz) :	17M8G7D (QPSK) / 17M9W7D (16-QAM)

Date(s) of Tests: August 05, 2014 ~ August 11, 2014

Antenna Specification

Manufacturer: Ace Technology

Antenna type: Internal Antenna

Peak Gain: Band 17: -7.16 dBi
Band 4: 0.21 dBi

2. INTRODUCTION

2.1. EUT DESCRIPTION

The LG Electronics MobileComm U.S.A., Inc. LG-D390n GSM/WCDMA/LTE phone with Bluetooth/WLAN/NFC consists of LTE 4 and 17.

2.2. MEASURING INSTRUMENT CALIBRATION

The measuring equipment, which was utilized in performing the tests documented herein, has been calibrated in accordance with the manufacturer's recommendations for utilizing calibration equipment, which is traceable to recognized national standards.

2.3. TEST FACILITY

The Fully-anechoic and conducted measurement facility used to collect the radiated data are located at the 74, Seoicheon-ro 578beon-gil, Majang-myeon, Icheon-si, Gyeonggi-do, Korea.

3. DESCRIPTION OF TESTS

3.1 CONDUCTED OUTPUT POWER

Test Procedure

Conducted Output Power is tested in accordance with KDB971168 D01 Power Meas License Digital Systems v02r01, June 7, 2013, Section 5.2.

5.2.1 Procedure for use with a spectrum/signal analyzer when EUT can be configured to transmit continuously or when sweep triggering/signal gating can be properly implemented

The EUT is considered to transmit continuously if it can be configured to transmit at a burst duty cycle of greater than or equal to 98% throughout the duration of the measurement. If this condition can be achieved, then the following procedure can be used to measure the average output power of the EUT.

This procedure can also be used when the EUT cannot be configured to transmit continuously, provided that the measurement instrument can be configured to trigger a sweep at the beginning of each full-power transmission burst, and the sweep time is less than or equal to the minimum transmission time during each burst (*i.e.*, no burst off-time is to be included in the measurement).

- a) Set span to at least 1.5 times the OBW.
- b) Set RBW = 1-5% of the OBW, not to exceed 1 MHz.
- c) Set VBW $\geq 3 \times$ RBW.
- d) Set number of points in sweep $\geq 2 \times$ span / RBW.
- e) Sweep time = auto-couple.
- f) Detector = RMS (power averaging).
- g) If the EUT can be configured to transmit continuously (*i.e.*, burst duty cycle $\geq 98\%$), then set the trigger to free run.
- h) If the EUT cannot be configured to transmit continuously (*i.e.*, burst duty cycle $< 98\%$), then use a sweep trigger with the level set to enable triggering only on full power bursts and configure the EUT to transmit at full power for the entire duration of each sweep. Ensure that the sweep time is less than or equal to the transmission burst duration.
- i) Trace average at least 100 traces in power averaging (*i.e.*, RMS) mode.
- j) Compute the power by integrating the spectrum across the OBW of the signal using the instrument's band power measurement function, with the band limits set equal to the OBW band edges. If the instrument does not have a band power function, then sum the spectrum levels (in linear power units) at intervals equal to the RBW extending across the entire OBW of the spectrum.

3.2 ERP/EIRP RADIATED POWER AND RADIATED SPURIOUS EMISSIONS

Note: ERP(Effective Radiated Power), EIRP(Effective Isotropic Radiated Power)

Test Procedure

Radiated emission measurements are performed in the Fully-anechoic chamber. The equipment under test is placed on a non-conductive table 3-meters away from the receive antenna in accordance with ANSI/TIA-603-C-2004 Clause 2.2.17. The turntable is rotated through 360 degrees, and the receiving antenna scans in order to determine the level of the maximized emission. The level and position of the maximized emission is recorded with the spectrum analyzer using a positive peak detector.

A half wave dipole is then substituted in place of the EUT. For emissions above 1GHz, a horn antenna is substituted in place of the EUT. The substitute antenna is driven by a signal generator and the previously recorded signal was duplicated.

The power is calculated by the following formula;

$$P_{d(\text{dBm})} = P_{g(\text{dBm})} - \text{cable loss}_{(\text{dB})} + \text{antenna gain}_{(\text{dB})}$$

Where: P_d is the dipole equivalent power and P_g is the generator output power into the substitution antenna.

The maximum EIRP is calculated by adding the forward power to the calibrated source plus its appropriate gain value. These steps are repeated with the receiving antenna in both vertical and horizontal polarization. the difference between the gain of the horn and an isotropic antenna are taken into consideration

Radiated spurious emissions

: Frequency Range : 30 MHz ~ 10th Harmonics of highest channel fundamental frequency.

3.3 PEAK-AVERAGE RATIO.

Test Procedure

Peak to Average Power Ratio is tested in accordance with KDB971168 D01 Power Meas License Digital Systems v02r01, June 7, 2013, Section 5.7.

- Section 5.7.1 CCDF Procedure

- a) Set resolution/measurement bandwidth \geq signal's occupied bandwidth;
- b) Set the number of counts to a value that stabilizes the measured CCDF curve;
- c) Set the measurement interval as follows:
 - 1) for continuous transmissions, set to 1 ms,
 - 2) for burst transmissions, employ an external trigger that is synchronized with the EUT burst timing sequence, or use the internal burst trigger with a trigger level that allows the burst to stabilize and set the measurement interval to a time that is less than or equal to the burst duration.
- d) Record the maximum PAPR level associated with a probability of 0.1%.

- Section 5.7.2 Alternate Procedure

Use one of the procedures presented in 5.1 to measure the total peak power and record as P_{Pk} . Use one of the applicable procedures presented 5.2 to measure the total average power and record as P_{Avg} . Determine the P.A.R. from: $P.A.R._{(dB)} = P_{Pk (dBm)} - P_{Avg (dBm)}$ (P_{Avg} = Average Power + Duty cycle Factor)

5.1.1 Peak power measurements with a spectrum/signal analyzer or EMI receiver

The following procedure can be used to determine the total peak output power.

- a) Set the RBW \geq OBW.
- b) Set VBW $\geq 3 \times$ RBW.
- c) Set span $\geq 2 \times$ RBW
- d) Sweep time = auto couple.
- e) Detector = peak.
- f) Ensure that the number of measurement points \geq span/RBW.
- g) Trace mode = max hold.
- h) Allow trace to fully stabilize.
- i) Use the peak marker function to determine the peak amplitude level.

5.2.2 Procedures for use with a spectrum/signal analyzer when EUT cannot be configured to transmit continuously and sweep triggering/signal gating cannot be properly implemented

If the EUT cannot be configured to transmit continuously (burst duty cycle < 98%), then one of the following procedures can be used. The selection of the applicable procedure will depend on the characteristics of the measured burst duty cycle.

Measure the burst duty cycle with a spectrum/signal analyzer or EMC receiver can be used in zero-span mode if the response time and spacing between bins on the sweep are sufficient to permit accurate measurement of the burst on/off time of the transmitted signal.

5.2.2.2 Constant burst duty cycle

If the measured burst duty cycle is constant (i.e., duty cycle variations are less than ± 2 percent), then:

- a) Set span to at least 1.5 times the OBW.
- b) Set RBW = 1-5% of the OBW, not to exceed 1 MHz.
- c) Set VBW $\geq 3 \times$ RBW.
- d) Number of points in sweep $\geq 2 \times$ span / RBW. (This gives bin-to-bin spacing \leq RBW/2, so that narrowband signals are not lost between frequency bins.)
- e) Sweep time = auto.
- f) Detector = RMS (power averaging).
- g) Set sweep trigger to "free run".
- h) Trace average at least 100 traces in power averaging (i.e., RMS) mode.
- i) Compute power by integrating the spectrum across the OBW of the signal using the instrument's band power measurement function with band limits set equal to the OBW band edges. If the instrument does not have a band power function, sum the spectrum levels (in power units) at intervals equal to the RBW extending across the entire OBW of the spectrum.
- j) Add $10 \log (1/x)$, where x is the duty cycle, to the measured power in order to compute the average power during the actual transmission times (because the measurement represents an average over both the on and off times of the transmission).

For example, add $10 \log (1/0.25) = 6$ dB if the duty cycle is a constant 25%.

3.4 OCCUPIED BANDWIDTH.

Test set-up

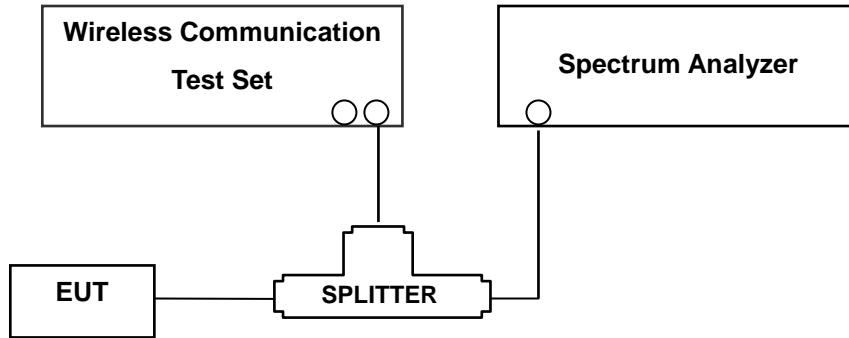

(Configuration of conducted Emission measurement)

Test Procedure

OBW is tested in accordance with KDB971168 D01 Power Meas License Digital Systems v02r01, June 7, 2013, Section 4.2..

The EUT was setup to maximum output power at its lowest channel. The occupied bandwidth was measured using a spectrum analyzer. The measurements are repeated for the highest and a middle channel. The EUT's occupied bandwidth is measured as the width of the signal between two points, one below the carrier center frequency and one above the carrier frequency, outside of which all emissions are attenuated at least 26 dB below the transmitter power. Plots of the EUT's occupied bandwidth are shown herein.

3.5 BLOCK B FREQUENCY RANGE (704 – 710 and 734 – 740 MHz, 777 – 792 MHz)

§27.5(c)

698-746 MHz Band. The following frequencies are available for licensing pursuant to this part in the 698–746 MHz band: (1) Three paired channel blocks of 12 MHz each are available for assignment as follows :

Block A : 698 – 704 MHz and 728 – 734 MHz ;

Block B : 704 – 710 MHz and 734 – 740 MHz ; and

Block C : 710 – 716 MHz and 740 – 746 MHz.

The EUT is only being authorized for operation in Blocks B and C.

3.6 AWS – MOBILE FREQUENCY BLOCKS (1710 – 1755 MHz)

§27.5(h)

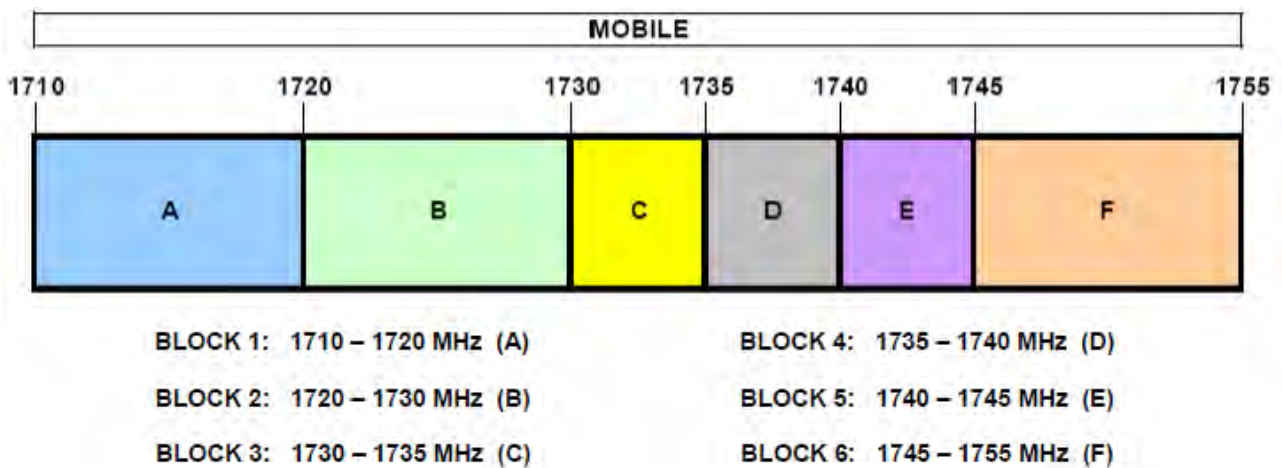

3.7 SPURIOUS AND HARMONIC EMISSIONS AT ANTENNA TERMINAL.

Test Procedure

Spurious and harmonic emissions at antenna terminal is tested in accordance with KDB971168 D01 Power Meas License Digital Systems v02r01, June 7, 2013, Section 6.0.

The level of the carrier and the various conducted spurious and harmonic frequencies is measured by means of a calibrated spectrum analyzer.

The spectrum is scanned from the lowest frequency generated in the equipment up to a frequency including its 10th harmonic. On any frequency outside a licensee's frequency block, the power of any emission shall be attenuated below the transmitter power (P) by at least $43 + 10 \log(P)$ dB. Compliance with these provisions is based on the use of measurement instrumentation employing a resolution bandwidth of 1 MHz or greater. However, in the 100 kHz bands immediately outside and adjacent to the frequency block a resolution bandwidth of at least 30kHz bandwidth may be employed. The emission bandwidth is defined as the width of the signal between two points, one below the carrier center frequency and one above the carrier center frequency

NOTES: The analyzer plot offsets were determined by below conditions.

- For LTE Band 17, total offset 26.8 dBm = 20 dBm attenuator + 6 dBm Divider + 0.8 dBm RF cables.
- For LTE Band 4, total offset 27.5 dBm = 20 dBm attenuator + 6 dBm Divider + 1.5 dBm RF cables.

3.8 FREQUENCY STABILITY / VARIATION OF AMBIENT TEMPERATURE

Test Set-up

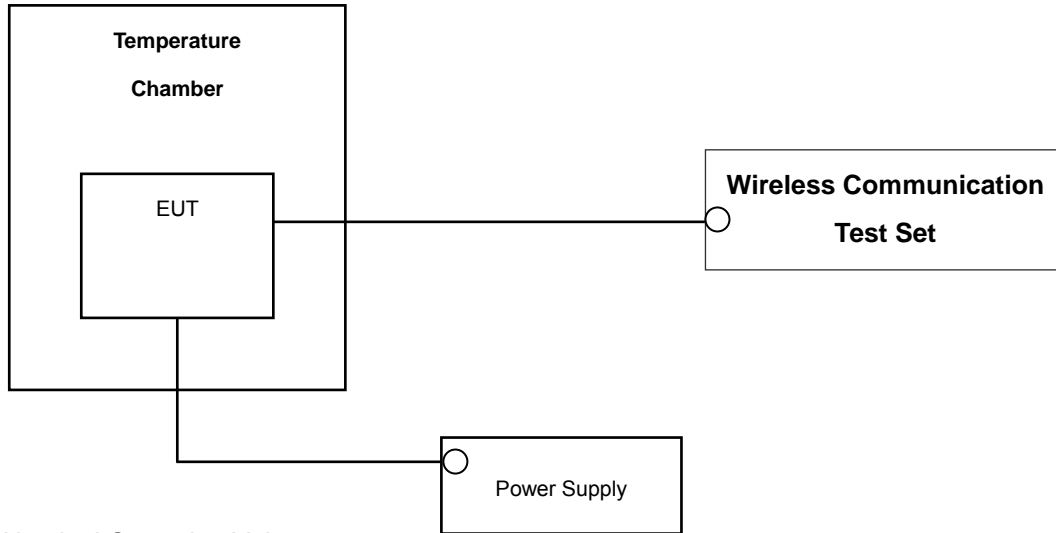

* Nominal Operating Voltage

Test Procedure

Frequency stability is tested in accordance with ANSI/TIA-603-C-2004 section 2.2.2

The frequency stability of the transmitter is measured by:

- a.) **Temperature:** The temperature is varied from - 30 °C to + 50 °C using an environmental chamber.
- b.) **Primary Supply Voltage:** The primary supply voltage is varied from the end point to 115 % of the voltage normally at the input to the device or at the power supply terminals if cables are not normally supplied.

Specification — the frequency stability shall be sufficient to ensure that the fundamental emission stays within the authorized frequency block(LTE Band4). The frequency stability of the transmitter shall be maintained within $\pm 0.00025\%$ (± 2.5 ppm) of the center frequency(LTE Band17).

Time Period and Procedure:

The carrier frequency of the transmitter is measured at room temperature (20°C to provide a reference).

1. The equipment is turned on in a “standby” condition for one minute before applying power to the transmitter. Measurement of the carrier frequency of the transmitter is made within one minute after applying power to the transmitter.
2. Frequency measurements are made at 10°C intervals ranging from -30°C to +50°C. A period of at least one half-hour is provided to allow stabilization of the equipment at each temperature level.

4. LIST OF TEST EQUIPMENT

Manufacture	Model/ Equipment	Serial Number	Calibration Date	Calibration Interval	Calibration Due
Agilent	N1921A/ Power Sensor	MY45241059	07/09/2014	Annual	07/09/2015
Agilent	N1911A/ Power Meter	MY45100523	01/24/2014	Annual	01/24/2015
MITEQ	AMF-6D-001180-35-20P/AMP	1081666	09/12/2013	Annual	09/12/2014
Wainwright	WHK1.2/15G-10EF/H.P.F	4	06/17/2014	Annual	06/17/2015
Wainwright	WHK3.3/18G-10EF/H.P.F	2	06/17/2014	Annual	06/17/2015
Hewlett Packard	11667B / Power Splitter	10545	02/22/2014	Annual	02/22/2015
Digital	EP-3010/ Power Supply	3110117	10/29/2013	Annual	10/29/2014
Schwarzbeck	UHAP/ Dipole Antenna	557	03/05/2013	Biennial	03/05/2015
Schwarzbeck	UHAP/ Dipole Antenna	558	05/03/2013	Biennial	05/03/2015
Korea Engineering	KR-1005L / Chamber	KRAB05063-3CH	10/30/2013	Annual	10/30/2014
Schwarzbeck	BBHA 9120D/ Horn Antenna	1191	12/03/2013	Biennial	12/03/2015
Schwarzbeck	BBHA 9120D/ Horn Antenna	1151	10/05/2013	Biennial	10/05/2015
Agilent	E4440A/Spectrum Analyzer	US45303008	04/09/2014	Annual	04/09/2015
WEINSCHEL	ATTENUATOR	BR0592	10/28/2013	Annual	10/28/2014
REOHDE&SCHWARZ	FSV40/Spectrum Analyzer	1307.9002K40-100931-NK	06/09/2014	Annual	06/09/2015
Agilent	8960 (E5515C)/ Base Station	GB45070669	08/31/2013	Annual	08/31/2014

5. SUMMARY OF TEST RESULTS

FCC Part Section(s)	Test Description	Test Limit	Test Condition	Test Result
2.1049, 27.53	Occupied Bandwidth	N/A	CONDUCTED	PASS
2.1051, 27.53(g), 27.53(h)	Band Edge / Spurious and Harmonic Emissions at Antenna Terminal.	< 43 +10 log ₁₀ (P[Watts]) at Band Edge and for all-of-band emissions		PASS
27.50(d)(5)	Peak-Average Ratio	< 13 dB		PASS
2.1046	Conducted Output Power	N/A		PASS
2.1055, 27.54	Frequency stability / variation of ambient temperature	< 2.5 ppm		PASS
27.50(c)(10)	Effective Radiated Power (Band 17)	< 3 Watts max. ERP	RADIATED	PASS
27.50(d)(4)	Equivalent Isotropic Radiated Powe (Band 4)	< 1 Watts max. EIRP		PASS
				PASS
2.1053, 27.53(g), 27.53(h)	Undesirable Out-of-Band Emissions	< 43 +10 log ₁₀ (P[Watts]) for all out-of-band emissions		PASS

*: See SAR Report

6. SAMPLE CALCULATION

A. ERP Sample Calculation

Mode	Ch./ Freq.		Measured Level(dBm)	Substitute LEVEL(dBm)	Ant. Gain (dBd)	C.L	Pol.	ERP	
	channel	Freq.(MHz)						W	dBm
LTE	23755	706.5	-28.75	29.60	-10.21	0.76	V	0.073	18.63

ERP = SubstituteLEVEL(dBm) + Ant. Gain – CL(Cable Loss)

- 1) The EUT mounted on a wooden tripod is 0.8 meter above test site ground level.
- 2) During the test , the turn table is rotated and the antenna height is found.
- 3) Record the field strength meter's level.
- 4) Replace the EUT with dipole/Horn antenna that is connected to a calibrated signal generator.
- 5) Increase the signal generator output till the field strength meter's level is equal to the item (3).
- 6) The signal generator output level with Ant. Gain and cable loss are the rating of effective radiated power (**ERP**).

B. Emission Designator

QPSK Modulation

Emission Designator = 4M48G7D

LTE BW = 4.48 MHz

G = Phase Modulation

7 = Quantized/Digital Info

D = Data transmission; telemetry; telecommand

16QAM Modulation

Emission Designator = 4M48W7D

LTE BW = 4.48 MHz

W = main carrier modulated in a combination of two

or more of the following modes;

amplitude, angle, pulse

7 = Quantized/Digital Info

D = Data transmission; telemetry; telecommand

7. TEST DATA

7.1 EFFECTIVE RADIATED POWER OUTPUT

Freq (MHz)	Bandwidth	Modulation	Measured Level (dBm)	Substitute Level (dBm)	Ant. Gain(dBd)	C.L	Pol	ERP	
								W	dBm
706.5	5 MHz	QPSK	-27.68	30.67	-10.21	0.76	V	0.093	19.70
		16-QAM	-27.66	30.69	-10.21	0.76	V	0.094	19.72
710.0		QPSK	-27.69	30.70	-10.22	0.77	V	0.094	19.71
		16-QAM	-27.65	30.74	-10.22	0.77	V	0.094	19.75
713.5		QPSK	-27.61	31.18	-10.24	0.78	V	0.104	20.16
		16-QAM	-27.68	31.11	-10.24	0.78	V	0.102	20.09

Effective Radiated Power Data (Band 17 – 5 MHz)

Note: Worst case is 1 resource block

Freq (MHz)	Bandwidth	Modulation	Measured Level (dBm)	Substitute Level (dBm)	Ant. Gain(dBd)	C.L	Pol	ERP	
								W	dBm
709.0	10 MHz	QPSK	-27.72	30.64	-10.22	0.79	V	0.092	19.63
		16-QAM	-27.26	31.10	-10.22	0.79	V	0.102	20.09
710.0		QPSK	-27.82	30.57	-10.22	0.77	V	0.091	19.58
		16-QAM	-27.51	30.88	-10.22	0.77	V	0.097	19.89
711.0		QPSK	-27.40	31.17	-10.23	0.77	V	0.104	20.17
		16-QAM	-27.23	31.34	-10.23	0.77	V	0.108	20.34

Effective Radiated Power Data (Band 17 – 10 MHz)

Note: Worst case is 1 resource block.

NOTES:

Effective Radiated Power Output Measurements by Substitution Method

according to ANSI/TIA/EIA-603-C-2004, Aug. 17, 2004:

The EUT was placed on a non-conductive styrofoam resin table 3-meters from the receive antenna. The receive antenna height and turntable rotation was adjusted for the highest reading on the receive spectrum analyzer.

A half-wave dipole was substituted in place of the EUT. This dipole antenna was driven by a signal generator and the level of the signal generator was adjusted to obtain the same receive spectrum analyzer reading. The conducted power at the terminals of the dipole is measured. The ERP is recorded.

Also, we have done x, y, z planes in EUT and horizontal and vertical polarization in detecting antenna. The worst case of the EUT is y plane in LTE mode. Also worst case of detecting Antenna is vertical polarization in LTE mode.

7.2 EQUIVALENT ISOTROPIC RADIATED POWER OUTPUT

Freq (MHz)	Bandwidth	Modulation	Measured Level (dBm)	Substitute Level (dBm)	Ant. Gain(dBi)	C.L	Pol	EIRP	
								W	dBm
1710.7	1.4 MHz	QPSK	-13.13	18.45	9.87	1.16	H	0.520	27.16
		16-QAM	-12.70	18.88	9.87	1.16	H	0.574	27.59
1732.5		QPSK	-15.14	16.42	9.90	1.16	H	0.328	25.16
		16-QAM	-14.96	16.60	9.90	1.16	H	0.342	25.34
1754.3		QPSK	-13.01	18.34	10.01	1.17	H	0.522	27.18
		16-QAM	-12.97	18.38	10.01	1.17	H	0.527	27.22

Effective Radiated Power Data (Band 4 – 1.4 MHz)

Note: Worst case is 1 resource block.

Freq (MHz)	Bandwidth	Modulation	Measured Level (dBm)	Substitute Level (dBm)	Ant. Gain(dBi)	C.L	Pol	EIRP	
								W	dBm
1711.5	3 MHz	QPSK	-13.34	18.23	9.87	1.16	H	0.494	26.94
		16-QAM	-12.93	18.64	9.87	1.16	H	0.543	27.35
1732.5		QPSK	-15.29	16.27	9.90	1.16	H	0.317	25.01
		16-QAM	-15.04	16.52	9.90	1.16	H	0.336	25.26
1753.5		QPSK	-12.82	18.48	10.01	1.17	H	0.540	27.32
		16-QAM	-12.63	18.67	10.01	1.17	H	0.564	27.51

Effective Radiated Power Data (Band 4 – 3 MHz)

Note: Worst case is 1 resource block.

Freq (MHz)	Bandwidth	Modulation	Measured Level (dBm)	Substitute Level (dBm)	Ant. Gain(dBi)	C.L	Pol	EIRP	
								W	dBm
1712.5	5 MHz	QPSK	-13.26	18.25	9.87	1.16	H	0.497	26.96
		16-QAM	-12.61	18.90	9.87	1.16	H	0.577	27.61
1732.5		QPSK	-15.39	16.17	9.90	1.16	H	0.310	24.91
		16-QAM	-15.21	16.35	9.90	1.16	H	0.323	25.09
1752.5		QPSK	-13.03	18.27	10.01	1.17	H	0.514	27.11
		16-QAM	-12.76	18.54	10.01	1.17	H	0.547	27.38

Effective Radiated Power Data (Band 4 – 5 MHz)

Note: Worst case is 1 resource block.

Freq (MHz)	Bandwidth	Modulation	Measured Level (dBm)	Substitute Level (dBm)	Ant. Gain(dBi)	C.L	Pol	EIRP	
								W	dBm
1715.0	10 MHz	QPSK	-13.02	18.63	9.87	1.16	H	0.542	27.34
		16-QAM	-12.80	18.85	9.87	1.16	H	0.570	27.56
1732.5		QPSK	-15.40	16.16	9.90	1.16	H	0.309	24.90
		16-QAM	-15.29	16.27	9.90	1.16	H	0.317	25.01
1750.0		QPSK	-13.09	18.21	10.01	1.17	H	0.507	27.05
		16-QAM	-12.89	18.41	10.01	1.17	H	0.531	27.25

Effective Radiated Power Data (Band 4 – 10 MHz)

Note: Worst case is 1 resource block.

Freq (MHz)	Bandwidth	Modulation	Measured Level (dBm)	Substitute Level (dBm)	Ant. Gain(dBi)	C.L	Pol	EIRP	
								W	dBm
1717.5	15 MHz	QPSK	-12.97	18.69	9.88	1.16	H	0.551	27.41
		16-QAM	-13.17	18.49	9.88	1.16	H	0.526	27.21
1732.5		QPSK	-15.22	16.34	9.90	1.16	H	0.322	25.08
		16-QAM	-15.18	16.38	9.90	1.16	H	0.325	25.12
1747.5		QPSK	-13.77	17.59	9.99	1.16	H	0.439	26.42
		16-QAM	-13.79	17.57	9.99	1.16	H	0.437	26.40

Effective Radiated Power Data (Band 4 – 15 MHz)

Note: Worst case is 1 resource block.

Freq (MHz)	Bandwidth	Modulation	Measured Level (dBm)	Substitute Level (dBm)	Ant. Gain(dBi)	C.L	Pol	EIRP	
								W	dBm
1720.0	20 MHz	QPSK	-13.59	17.97	9.88	1.16	H	0.467	26.69
		16-QAM	-12.47	19.09	9.88	1.16	H	0.604	27.81
1732.5		QPSK	-14.56	17.00	9.90	1.16	H	0.375	25.74
		16-QAM	-14.74	16.82	9.90	1.16	H	0.360	25.56
1745.0		QPSK	-14.54	16.87	9.96	1.16	H	0.369	25.67
		16-QAM	-14.51	16.90	9.96	1.16	H	0.372	25.70

Effective Radiated Power Data (Band 4 – 20 MHz)

Note: Worst case is 1 resource block.

NOTES:

Effective Radiated Power Output Measurements by Substitution Method
according to ANSI/TIA/EIA-603-C-2004, Aug. 17, 2004:

The EUT was placed on a non-conductive styrofoam resin table 3-meters from the receive antenna. The receive antenna height and turntable rotation was adjusted for the highest reading on the receive spectrum analyzer.

A Horn antenna was substituted in place of the EUT. This Horn antenna was driven by a signal generator and the level of the signal generator was adjusted to obtain the same receive spectrum analyzer reading. The conducted power at the terminals of the Horn antenna is measured. The difference between the gain of the horn and an isotropic antenna is taken into consideration and the EIRP is recorded.

Also, we have done x, y, z planes in EUT and horizontal and vertical polarization in detecting antenna. The worst case of the EUT is x plane in LTE mode. Also worst case of detecting Antenna is horizontal polarization in LTE mode.

7.3 RADIATED SPURIOUS EMISSIONS

7.3.1 RADIATED SPURIOUS EMISSIONS (Band 17)

- ▣ OPERATING FREQUENCY : 706.50 MHz
- ▣ MEASURED OUTPUT POWER: 20.16 dBm = 0.104 W
- ▣ MODULATION SIGNAL: 5 MHz QPSK
- ▣ DISTANCE: 3 meters
- ▣ LIMIT: $43 + 10 \log_{10}(W) =$ 33.16 dBc

Ch	Freq (MHz)	Measured Level (dBm)	Ant. Gain (dBd)	Substitute Level (dBm)	C.L	Pol	ERP (dBm)	dBc
23755 (706.50)	1413.0	-47.70	5.67	-51.77	1.05	H	-47.15	67.31
	2119.5	-42.44	7.40	-46.68	1.2	H	-40.48	60.64
	2826.0	-49.25	8.69	-52.72	1.46	V	-45.49	65.65
23790 (710.00)	1420.0	-47.59	5.71	-52.36	1.05	H	-47.70	67.86
	2130.0	-40.75	7.34	-44.87	1.24	V	-38.77	58.93
	2840.0	-50.52	8.75	-54.34	1.48	H	-47.07	67.23
23825 (713.50)	1427.0	-48.32	5.75	-52.93	1.04	H	-48.22	68.38
	2140.5	-44.91	7.27	-48.60	1.22	H	-42.55	62.71
	2854.0	-52.19	8.80	-55.89	1.46	V	-48.55	68.71

- NOTES:**
1. Radiated Spurious Emission Measurements at 3 meters by Substitution Method according to ANSI/TIA/EIA-603-C-2004, Aug. 17, 2004:
 2. We are performed all frequency to 10th harmonics from 30 MHz. Measurements above show only up to 3 maximum emissions noted, or would be lesser if no specific emissions from the EUT are recorded (ie: margin > 20 dB from the applicable limit) and considered that's already beyond the background noise floor.
 3. we have done x, y, z planes in EUT and horizontal and vertical polarization in detecting antenna.
 4. Worst case is 1 resource block.

- ▣ OPERATING FREQUENCY : 710.00 MHz
- ▣ MEASURED OUTPUT POWER: 20.34 dBm = 0.108 W
- ▣ MODULATION SIGNAL: 10 MHz 16-QAM
- ▣ DISTANCE: 3 meters
- ▣ LIMIT: $43 + 10 \log_{10}(W) =$ 33.34 dBc

Ch	Freq (MHz)	Measured Level (dBm)	Ant. Gain (dBd)	Substitute Level (dBm)	C.L	Pol	ERP (dBm)	dBc
23780 (709.00)	1,418.0	-47.39	5.70	-51.49	1.05	H	-46.84	67.18
	2,127.0	-46.88	7.36	-51.03	1.23	H	-44.90	65.24
	2,836.0	-49.41	8.69	-52.87	1.47	H	-45.65	65.99
23790 (710.00)	1,420.0	-48.58	5.71	-53.35	1.05	H	-48.69	69.03
	2,130.0	-47.95	7.34	-52.07	1.24	V	-45.97	66.31
	2,840.0	-51.48	8.75	-55.30	1.48	H	-48.03	68.37
23800 (711.00)	1,422.0	-48.11	5.72	-52.68	1.05	H	-48.01	68.35
	2,133.0	-47.96	7.33	-52.05	1.24	H	-45.96	66.30
	2,844.0	-50.77	8.77	-54.45	1.47	H	-47.15	67.49

NOTES: 1. Radiated Spurious Emission Measurements at 3 meters by Substitution Method

according to ANSI/TIA/EIA-603-C-2004, Aug. 17, 2004:

2. We are performed all frequency to 10th harmonics from 30 MHz. Measurements above show only up to 3 maximum emissions noted, or would be lesser if no specific emissions from the EUT are recorded (ie: margin > 20 dB from the applicable limit) and considered that's already beyond the background noise floor.
3. we have done x, y, z planes in EUT and horizontal and vertical polarization in detecting antenna.
4. Worst case is 1 resource block.

7.3.2 RADIATED SPURIOUS EMISSIONS (Band 4)

- ▣ OPERATING FREQUENCY : 1732.50 MHz
- ▣ MEASURED OUTPUT POWER: 27.59 dBm = 0.574 W
- ▣ MODULATION SIGNAL: 1.4 MHz 16-QAM
- ▣ DISTANCE: 3 meters
- ▣ LIMIT: $43 + 10 \log_{10}(W) =$ 40.59 dBc

Ch	Freq (MHz)	Measured Level (dBm)	Ant. Gain (dBi)	Substitute Level (dBm)	C.L	Pol	EIRP (dBm)	dBc
19957 (1710.7)	3,421.40	-44.10	12.36	-50.94	1.64	V	-40.22	67.81
	5,132.10	-53.14	12.34	-53.34	2.01	V	-43.01	70.60
	6,842.80	-57.79	12.17	-52.18	2.35	V	-42.36	69.95
20175 (1732.5)	3,465.00	-50.47	12.27	-57.00	1.63	V	-46.36	73.95
	5,197.50	-51.34	12.63	-51.89	2.11	V	-41.37	68.96
	6,930.00	-57.91	11.87	-51.76	2.41	H	-42.30	69.89
20393 (1754.3)	3,508.60	-44.70	12.15	-50.46	1.67	V	-39.98	67.57
	5,262.90	-56.30	12.91	-57.84	2.03	V	-46.96	74.55
	7,017.20	-58.40	11.59	-51.53	2.38	V	-42.32	69.91

- NOTES:**
1. Radiated Spurious Emission Measurements at 3 meters by Substitution Method according to ANSI/TIA/EIA-603-C-2004, Aug. 17, 2004:
 2. We are performed all frequency to 10th harmonics from 30 MHz. Measurements above show only up to 3 maximum emissions noted, or would be lesser if no specific emissions from the EUT are recorded (ie: margin > 20 dB from the applicable limit) and considered that's already beyond the background noise floor.
 3. we have done x, y, z planes in EUT and horizontal and vertical polarization in detecting antenna.
 4. Worst case is 1 resource block.

- OPERATING FREQUENCY : 1732.50 MHz
- MEASURED OUTPUT POWER: 27.51 dBm = 0.564 W
- MODULATION SIGNAL: 3 MHz 16-QAM
- DISTANCE: 3 meters
- LIMIT: $43 + 10 \log_{10}(W) =$ 40.51 dBc

Ch	Freq (MHz)	Measured Level (dBm)	Ant. Gain (dBi)	Substitute Level (dBm)	C.L	Pol	EIRP (dBm)	dBc
19965 (1711.5)	3,423.00	-43.55	12.36	-50.39	1.64	V	-39.67	67.18
	5,134.50	-53.14	12.35	-53.36	2.00	H	-43.01	70.52
	6,846.00	-57.36	12.16	-51.73	2.36	H	-41.93	69.44
20175 (1732.5)	3,465.00	-50.73	12.27	-57.26	1.63	V	-46.62	74.13
	5,197.50	-47.98	12.63	-48.53	2.11	H	-38.01	65.52
	6,930.00	-57.43	11.87	-51.28	2.41	H	-41.82	69.33
20385 (1753.5)	3,507.00	-44.84	12.15	-50.60	1.67	V	-40.12	67.63
	5,260.50	-55.96	12.90	-57.50	2.02	H	-46.62	74.13
	7,014.00	-58.03	11.59	-51.21	2.33	V	-41.95	69.46

- NOTES:**
1. Radiated Spurious Emission Measurements at 3 meters by Substitution Method according to ANSI/TIA/EIA-603-C-2004, Aug. 17, 2004:
 2. We are performed all frequency to 10th harmonics from 30 MHz. Measurements above show only up to 3 maximum emissions noted, or would be lesser if no specific emissions from the EUT are recorded (ie: margin > 20 dB from the applicable limit) and considered that's already beyond the background noise floor.
 3. we have done x, y, z planes in EUT and horizontal and vertical polarization in detecting antenna.
 4. Worst case is 1 resource block.

- OPERATING FREQUENCY : 1732.50 MHz
- MEASURED OUTPUT POWER: 27.61 dBm = 0.577 W
- MODULATION SIGNAL: 5 MHz 16-QAM
- DISTANCE: 3 meters
- LIMIT: $43 + 10 \log_{10}(W) =$ 40.61 dBc

Ch	Freq (MHz)	Measured Level (dBm)	Ant. Gain (dBi)	Substitute Level (dBm)	C.L	Pol	EIRP (dBm)	dBc
19975 (1712.5)	3425.0	-48.03	12.35	-54.87	1.63	H	-44.15	71.76
	5137.5	-53.39	12.36	-53.63	1.99	V	-43.26	70.87
	6850.0	-58.30	12.15	-52.66	2.36	V	-42.87	70.48
20175 (1732.5)	3465.0	-49.80	12.27	-56.33	1.63	V	-45.69	73.30
	5197.5	-50.03	12.63	-50.58	2.11	V	-40.06	67.67
	6930.0	-56.89	11.87	-50.74	2.41	V	-41.28	68.89
20375 (1752.5)	3505.0	-44.77	12.15	-50.53	1.67	V	-40.05	67.66
	5257.5	-56.55	12.90	-58.00	2.02	H	-47.12	74.73
	7010.0	-57.19	11.61	-50.59	2.36	H	-41.34	68.95

- NOTES:**
1. Radiated Spurious Emission Measurements at 3 meters by Substitution Method according to ANSI/TIA/EIA-603-C-2004, Aug. 17, 2004:
 2. We are performed all frequency to 10th harmonics from 30 MHz. Measurements above show only up to 3 maximum emissions noted, or would be lesser if no specific emissions from the EUT are recorded (ie: margin > 20 dB from the applicable limit) and considered that's already beyond the background noise floor.
 3. we have done x, y, z planes in EUT and horizontal and vertical polarization in detecting antenna.
 4. Worst case is 1 resource block.

- OPERATING FREQUENCY : 1732.50 MHz
- MEASURED OUTPUT POWER: 27.56 dBm = 0.570 W
- MODULATION SIGNAL: 10 MHz 16-QAM
- DISTANCE: 3 meters
- LIMIT: $43 + 10 \log_{10}(W) =$ 40.56 dBc

Ch	Freq (MHz)	Measured Level (dBm)	Ant. Gain (dBi)	Substitute Level (dBm)	C.L	Pol	EIRP (dBm)	dBc
20000 (1715.0)	3430.0	-46.28	12.34	-53.37	1.63	V	-42.66	70.22
	5145.0	-54.36	12.38	-54.52	1.97	V	-44.11	71.67
	6860.0	-	-	-	-	-	-	-
20175 (1732.5)	3465.0	-50.75	12.27	-57.28	1.63	V	-46.64	74.20
	5197.5	-50.29	12.63	-50.84	2.11	H	-40.32	67.88
	6930.0	-57.47	11.87	-51.32	2.41	V	-41.86	69.42
20350 (1750.0)	3500.0	-43.71	12.15	-49.72	1.66	V	-39.23	66.79
	5250.0	-55.92	12.87	-57.33	2.03	H	-46.49	74.05
	7000.0	-57.53	11.65	-50.85	2.39	V	-41.59	69.15

- NOTES:**
1. Radiated Spurious Emission Measurements at 3 meters by Substitution Method according to ANSI/TIA/EIA-603-C-2004, Aug. 17, 2004:
 2. We are performed all frequency to 10th harmonics from 30 MHz. Measurements above show only up to 3 maximum emissions noted, or would be lesser if no specific emissions from the EUT are recorded (ie: margin > 20 dB from the applicable limit) and considered that's already beyond the background noise floor.
 3. we have done x, y, z planes in EUT and horizontal and vertical polarization in detecting antenna.
 4. Worst case is 1 resource block.

- OPERATING FREQUENCY : 1732.50 MHz
- MEASURED OUTPUT POWER: 27.41 dBm = 0.551 W
- MODULATION SIGNAL: 15 MHz QPSK
- DISTANCE: 3 meters
- LIMIT: $43 + 10 \log_{10}(W) =$ 40.41 dBc

Ch	Freq (MHz)	Measured Level (dBm)	Ant. Gain (dBi)	Substitute Level (dBm)	C.L	Pol	EIRP (dBm)	dBc
20025 (1717.5)	3435.0	-44.46	12.34	-51.27	1.63	V	-40.56	67.97
	5152.5	-54.19	12.40	-54.38	1.96	H	-43.94	71.35
	6870.0	-56.42	12.08	-51.22	2.36	H	-41.50	68.91
20175 (1732.5)	3465.0	-53.69	12.27	-60.22	1.63	H	-49.58	76.99
	5197.5	-49.65	12.63	-50.20	2.11	H	-39.68	67.09
	6930.0	-56.76	11.87	-50.61	2.41	H	-41.15	68.56
20325 (1747.5)	3495.0	-42.31	12.17	-48.35	1.65	V	-37.83	65.24
	5242.5	-51.97	12.83	-53.16	1.99	V	-42.32	69.73
	6990.0	-57.70	11.68	-50.38	2.38	H	-41.08	68.49

- NOTES:**
1. Radiated Spurious Emission Measurements at 3 meters by Substitution Method according to ANSI/TIA/EIA-603-C-2004, Aug. 17, 2004:
 2. We are performed all frequency to 10th harmonics from 30 MHz. Measurements above show only up to 3 maximum emissions noted, or would be lesser if no specific emissions from the EUT are recorded (ie: margin > 20 dB from the applicable limit) and considered that's already beyond the background noise floor.
 3. we have done x, y, z planes in EUT and horizontal and vertical polarization in detecting antenna.
 4. Worst case is 1 resource block.

- OPERATING FREQUENCY : 1732.50 MHz
- MEASURED OUTPUT POWER: 27.81 dBm = 0.604 W
- MODULATION SIGNAL: 20 MHz 16-QAM
- DISTANCE: 3 meters
- LIMIT: $43 + 10 \log_{10}(W) =$ 40.81 dBc

Ch	Freq (MHz)	Measured Level (dBm)	Ant. Gain (dBi)	Substitute Level (dBm)	C.L	Pol	EIRP (dBm)	dBc
20050 (1720.0)	3440.0	-45.00	12.33	-51.79	1.64	V	-41.10	68.91
	5160.0	-52.45	12.44	-52.79	1.98	V	-42.33	70.14
	6880.0	-	-	-	-	-	-	-
20175 (1732.5)	3465.0	-51.67	12.27	-58.20	1.63	V	-47.56	75.37
	5197.5	-47.68	12.63	-48.23	2.11	V	-37.71	65.52
	6930.0	-56.70	11.87	-50.55	2.41	V	-41.09	68.90
20300 (1745.0)	3490.0	-46.35	12.18	-52.54	1.65	V	-42.01	69.82
	5235.0	-49.77	12.81	-50.94	1.99	V	-40.12	67.93
	6980.0	-59.05	11.71	-52.18	2.37	V	-42.84	70.65

- NOTES:**
1. Radiated Spurious Emission Measurements at 3 meters by Substitution Method according to ANSI/TIA/EIA-603-C-2004, Aug. 17, 2004:
 2. We are performed all frequency to 10th harmonics from 30 MHz. Measurements above show only up to 3 maximum emissions noted, or would be lesser if no specific emissions from the EUT are recorded (ie: margin > 20 dB from the applicable limit) and considered that's already beyond the background noise floor.
 3. we have done x, y, z planes in EUT and horizontal and vertical polarization in detecting antenna.
 4. Worst case is 1 resource block.

7.4 PEAK-TO-AVERAGE RATIO

Band	Band Width	Frequency (MHz)	Modulation	Resource Block Size	Resource Block Offset	Data (dB)
Band 17	5 MHz	710.0	QPSK	25	0	5.24
			16-QAM	25	0	5.82
	10 MHz	710.0	QPSK	50	0	5.30
			16-QAM	50	0	5.89

Band	Band Width	Frequency (MHz)	Modulation	Resource Block Size	Resource Block Offset	Data (dB)
Band 4	1.4 MHz	1732.5	QPSK	6	0	3.25
			16-QAM	6	0	4.52
	3 MHz	1732.5	QPSK	15	0	4.79
			16-QAM	15	0	5.62
	5 MHz	1732.5	QPSK	25	0	4.75
			16-QAM	25	0	5.46
	10 MHz	1732.5	QPSK	50	0	4.81
			16-QAM	50	0	5.54
	15 MHz	1732.5	QPSK	75	0	4.56
			16-QAM	75	0	5.32
	20 MHz	1732.5	QPSK	100	0	4.78
			16-QAM	100	0	5.56

- Plots of the EUT's Peak- to- Average Ratio are shown Page 52 ~ 59

7.5 OCCUPIED BANDWIDTH

Band	Band Width (MHz)	Frequency (MHz)	Modulation	Resource Block Size	Resource Block Offset	Data (MHz)
Band 17	5	710.0	QPSK	25	0	4.4985
			16-QAM	25	0	4.4916
	10	710.0	QPSK	50	0	8.9794
			16-QAM	50	0	8.9384

Band	Band Width (MHz)	Frequency (MHz)	Modulation	Resource Block Size	Resource Block Offset	Data (MHz)
Band 4	1.4	1732.5	QPSK	6	0	1.0952
			16-QAM	6	0	1.0934
	3	1732.5	QPSK	15	0	2.6966
			16-QAM	15	0	2.6980
	5	1732.5	QPSK	25	0	4.4904
			16-QAM	25	0	4.4881
	10	1732.5	QPSK	50	0	8.9965
			16-QAM	50	0	8.9435
	15	1732.5	QPSK	75	0	13.4340
			16-QAM	75	0	13.4260
	20	1732.5	QPSK	100	0	17.8160
			16-QAM	100	0	17.8750

- Plots of the EUT's Occupied Bandwidth are shown Page 44 ~ 51.

7.6 CONDUCTED SPURIOUS EMISSIONS

Band	Band Width (MHz)	Frequency (MHz)	Modulation	Resource Block Size	Resource Block Offset	Frequency of Maximum Harmonic (GHz)	Maximum Data [dBm]
Band 17	5	706.5	QPSK	1	0	6.739750	-26.76
		710.0		1	0	6.340750	-26.28
		713.5		1	0	6.610750	-26.90
	10	709.0		1	0	6.981750	-26.65
		710.0		1	0	7.450250	-26.94
		711.0		1	0	6.975250	-26.08

Band	Band Width (MHz)	Frequency (MHz)	Modulation	Resource Block Size	Resource Block Offset	Frequency of Maximum Harmonic (GHz)	Maximum Data [dBm]
Band 4	1.4	1710.7	QPSK	1	0	6.943970	-25.86
		1732.5		1	0	6.980680	-25.99
		1754.3		1	0	6.961190	-26.38
	3	1711.5		1	0	6.992910	-26.38
		1732.5		1	0	6.940800	-25.02
		1753.5		1	0	6.933550	-26.43
	5	1712.5		1	0	6.999260	-25.97
		1732.5		1	0	6.807110	-26.38
		1752.5		1	0	6.990190	-25.96
	10	1715.0		1	0	6.799400	-26.03
		1732.5		1	0	6.991550	-26.15
		1750.0		1	0	6.942610	-26.09
	15	1717.5		1	0	6.947140	-25.71
		1732.5		1	0	6.987020	-24.78
		1747.5		1	0	6.841550	-25.58
	20	1720.0		1	0	6.956200	-25.87
		1732.5		1	0	6.967530	-26.38
		1745.0		1	0	6.977050	-25.42

- Plots of the EUT's Conducted Spurious Emissions are shown Page 88~ 111.

7.6.1 BAND EDGE

- Plots of the EUT's Band Edge are shown Page 60 ~ 87

7.7 FREQUENCY STABILITY / VARIATION OF AMBIENT TEMPERATURE

7.7.1 FREQUENCY STABILITY (LTE Band 17)

- ▣ OPERATING FREQUENCY: 710,000,000 Hz
- ▣ CHANNEL: 23790 (5 MHz)
- ▣ REFERENCE VOLTAGE: 3.8 VDC
- ▣ DEVIATION LIMIT: ± 0.000 25 % or 2.5 ppm

Voltage (%)	Power (VDC)	Temp. (°C)	Frequency (Hz)	Frequency Error (Hz)	Deviation (%)	ppm
100%	3.80	+20(Ref)	709 999 994	0	0.000 000	0.000
100%		-30	710 000 002	8.60	0.000 001	0.012
100%		-20	709 999 986	-7.50	-0.000 001	-0.011
100%		-10	709 999 997	3.40	0.000 000	0.005
100%		0	709 999 988	-5.70	-0.000 001	-0.008
100%		+10	709 999 999	5.50	0.000 001	0.008
100%		+30	709 999 989	-5.10	-0.000 001	-0.007
100%		+40	709 999 987	-6.50	-0.000 001	-0.009
100%		+50	709 999 986	-7.50	-0.000 001	-0.011
115%	4.37	+20	709 999 986	-8.00	-0.000 001	-0.011
Batt. Endpoint	3.23	+20	709 999 988	-5.40	-0.000 001	-0.008

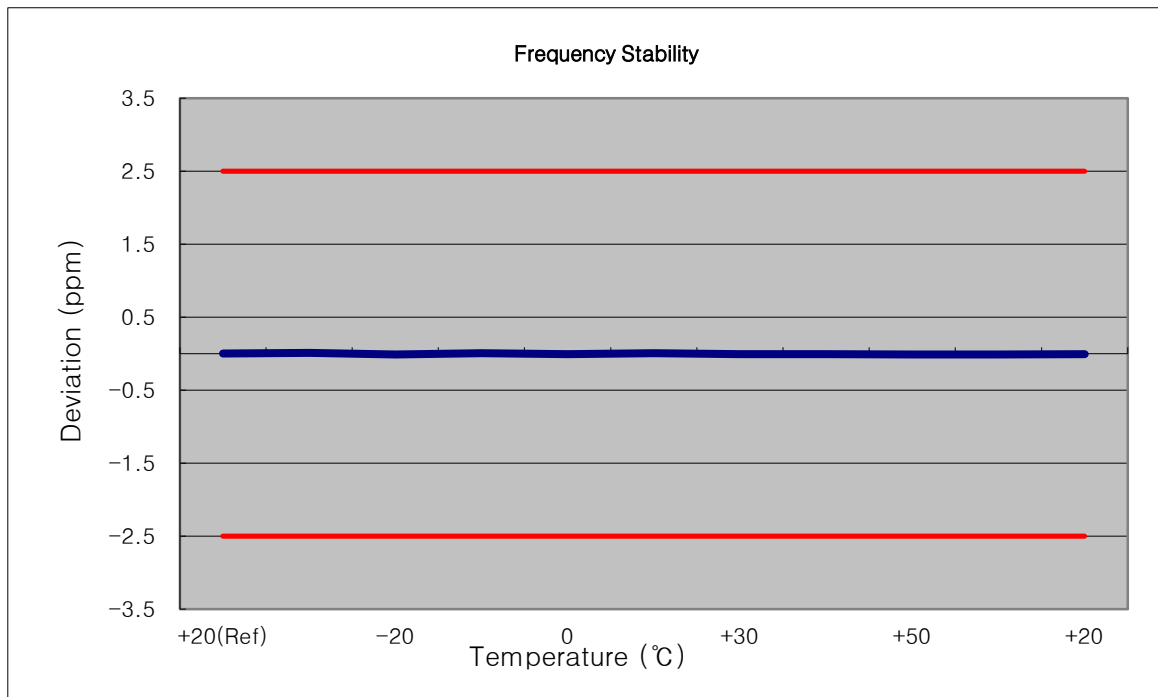

- ▣ OPERATING FREQUENCY: 710,000,000 Hz
- ▣ CHANNEL: 23790 (10 MHz)
- ▣ REFERENCE VOLTAGE: 3.8 VDC
- ▣ DEVIATION LIMIT: ± 0.000 25 % or 2.5 ppm

Voltage (%)	Power (VDC)	Temp. (°C)	Frequency (Hz)	Frequency Error (Hz)	Deviation (%)	ppm
100%	3.80	+20(Ref)	710 000 005	0	0.000 000	0.000
100%		-30	710 000 009	4.10	0.000 001	0.006
100%		-20	710 000 010	5.50	0.000 001	0.008
100%		-10	710 000 000	-4.30	-0.000 001	-0.006
100%		0	710 000 000	-4.80	-0.000 001	-0.007
100%		+10	710 000 001	-3.90	-0.000 001	-0.005
100%		+30	709 999 998	-6.60	-0.000 001	-0.009
100%		+40	710 000 001	-3.50	0.000 000	-0.005
100%		+50	710 000 001	-3.90	-0.000 001	-0.005
115%	4.37	+20	710 000 000	-4.40	-0.000 001	-0.006
Batt. Endpoint	3.23	+20	709 999 999	-5.70	-0.000 001	-0.008

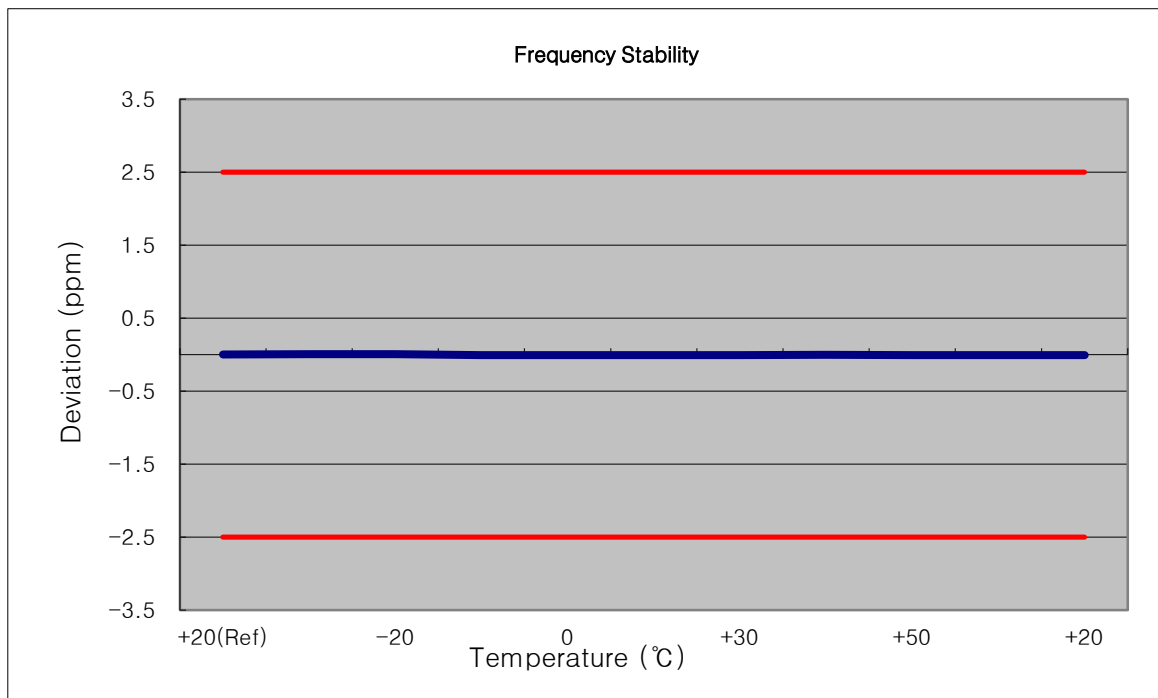

7.7.2 FREQUENCY STABILITY (LTE Band 4)

- OPERATING FREQUENCY: 1732,500,000 Hz
- CHANNEL: 20175 (1.4 MHz)
- REFERENCE VOLTAGE: 3.8 VDC
- DEVIATION LIM IT: -

Voltage (%)	Power (VDC)	Temp. (°C)	Frequency (Hz)	Frequency Error (Hz)	Deviation (%)	ppm
100%	3.80	+20(Ref)	1732 499 987	0	0.000 000	0.000
100%		-30	1732 500 007	20.00	0.000 001	0.012
100%		-20	1732 500 001	14.00	0.000 001	0.008
100%		-10	1732 499 971	-15.80	-0.000 001	-0.009
100%		0	1732 499 974	-13.60	-0.000 001	-0.008
100%		+10	1732 500 002	15.20	0.000 001	0.009
100%		+30	1732 500 003	16.10	0.000 001	0.009
100%		+40	1732 500 002	14.80	0.000 001	0.009
100%		+50	1732 500 000	12.40	0.000 001	0.007
115%		4.37	+20	1732 500 003	15.90	0.000 001
Batt. Endpoint	3.23	+20	1732 500 001	13.50	0.000 001	0.008

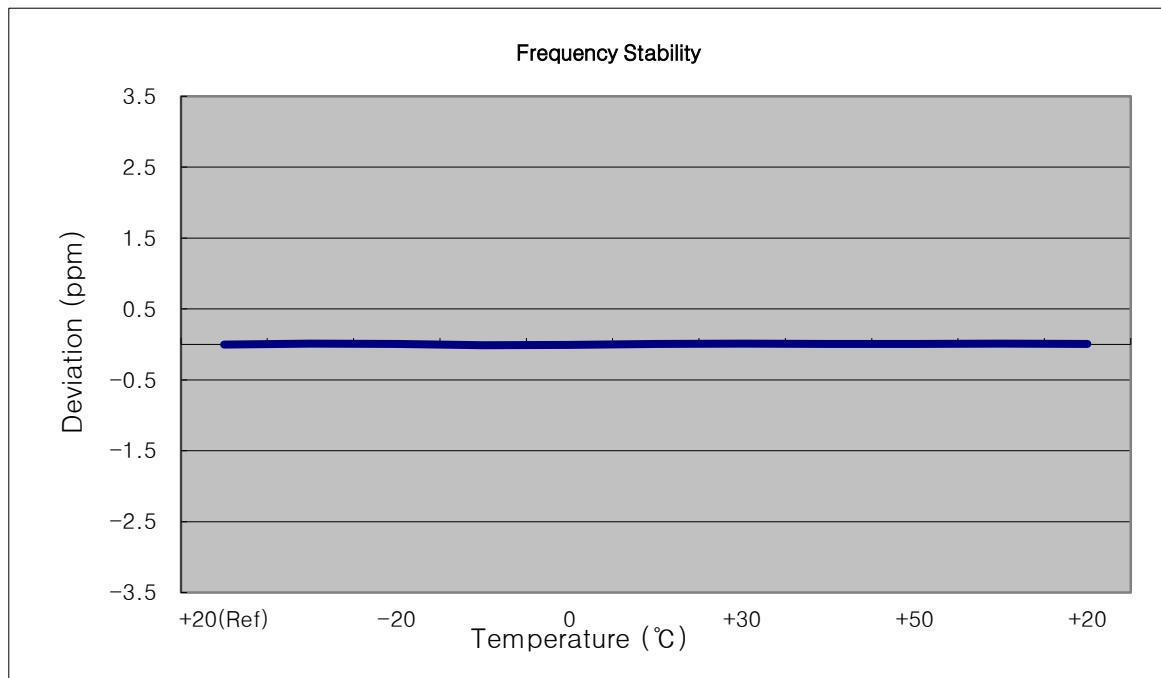

- OPERATING FREQUENCY: 1732,500,000 Hz
- CHANNEL: 20175 (3 MHz)
- REFERENCE VOLTAGE: 3.8 VDC
- DEVIATION LIMIT: -

Voltage (%)	Power (VDC)	Temp. (°C)	Frequency (Hz)	Frequency Error (Hz)	Deviation (%)	ppm
100%	3.80	+20(Ref)	1732 499 984	0	0.000 000	0.000
100%		-30	1732 499 997	13.10	0.000 001	0.008
100%		-20	1732 500 000	15.70	0.000 001	0.009
100%		-10	1732 499 997	13.00	0.000 001	0.008
100%		0	1732 500 005	20.70	0.000 001	0.012
100%		+10	1732 500 001	16.60	0.000 001	0.010
100%		+30	1732 500 004	19.60	0.000 001	0.011
100%		+40	1732 499 999	14.40	0.000 001	0.008
100%		+50	1732 500 002	17.30	0.000 001	0.010
115%		4.37	+20	1732 499 994	9.60	0.000 001
Batt. Endpoint	3.23	+20	1732 500 006	21.40	0.000 001	0.012

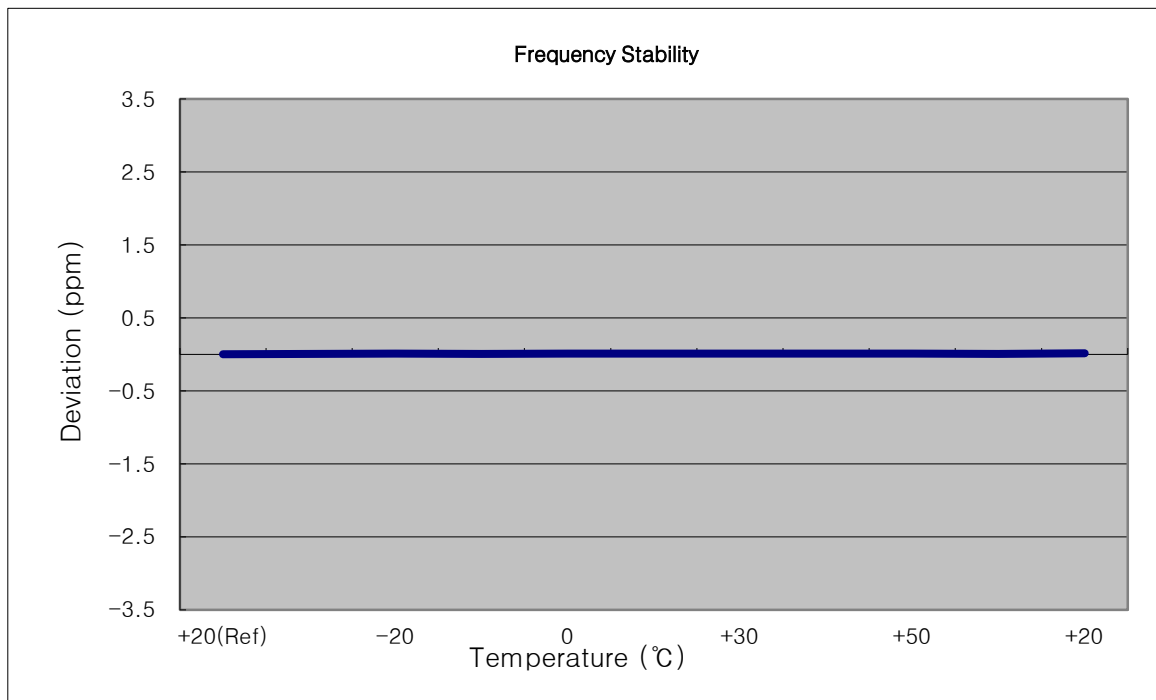

- OPERATING FREQUENCY: 1732,500,000 Hz
- CHANNEL: 20175 (5 MHz)
- REFERENCE VOLTAGE: 3.8 VDC
- DEVIATION LIMIT: -

Voltage (%)	Power (VDC)	Temp. (°C)	Frequency (Hz)	Frequency Error (Hz)	Deviation (%)	ppm
100%	3.80	+20(Ref)	1732 499 990	0	0.000 000	0.000
100%		-30	1732 500 000	10.00	0.000 001	0.006
100%		-20	1732 500 002	11.40	0.000 001	0.007
100%		-10	1732 499 999	9.00	0.000 001	0.005
100%		0	1732 499 983	-7.60	0.000 000	-0.004
100%		+10	1732 500 003	12.60	0.000 001	0.007
100%		+30	1732 499 981	-8.90	-0.000 001	-0.005
100%		+40	1732 500 005	15.00	0.000 001	0.009
100%		+50	1732 499 998	7.20	0.000 000	0.004
115%	4.37	+20	1732 499 998	7.80	0.000 000	0.005
Batt. Endpoint	3.23	+20	1732 500 000	9.60	0.000 001	0.006

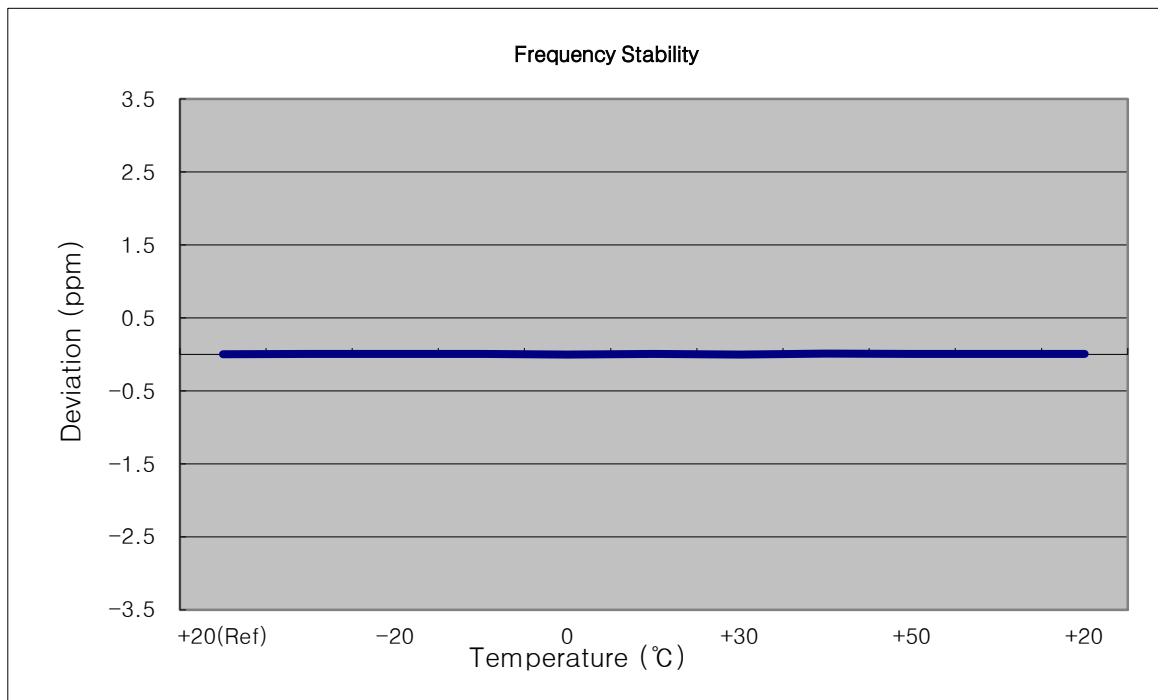

- OPERATING FREQUENCY: 1732,500,000 Hz
- CHANNEL: 20175 (10 MHz)
- REFERENCE VOLTAGE: 3.8 VDC
- DEVIATION LIMIT: -

Voltage (%)	Power (VDC)	Temp. (°C)	Frequency (Hz)	Frequency Error (Hz)	Deviation (%)	ppm
100%	3.80	+20(Ref)	1732 500 005	0	0.000 000	0.000
100%		-30	1732 500 015	10.00	0.000 001	0.006
100%		-20	1732 500 017	11.40	0.000 001	0.007
100%		-10	1732 500 014	8.10	0.000 000	0.005
100%		0	1732 500 015	9.30	0.000 001	0.005
100%		+10	1732 500 012	6.50	0.000 000	0.004
100%		+30	1732 500 017	11.20	0.000 001	0.006
100%		+40	1732 500 009	3.90	0.000 000	0.002
100%		+50	1732 500 013	7.50	0.000 000	0.004
115%		4.37	+20	1732 500 019	13.40	0.000 001
Batt. Endpoint	3.23	+20	1732 500 013	7.80	0.000 000	0.005

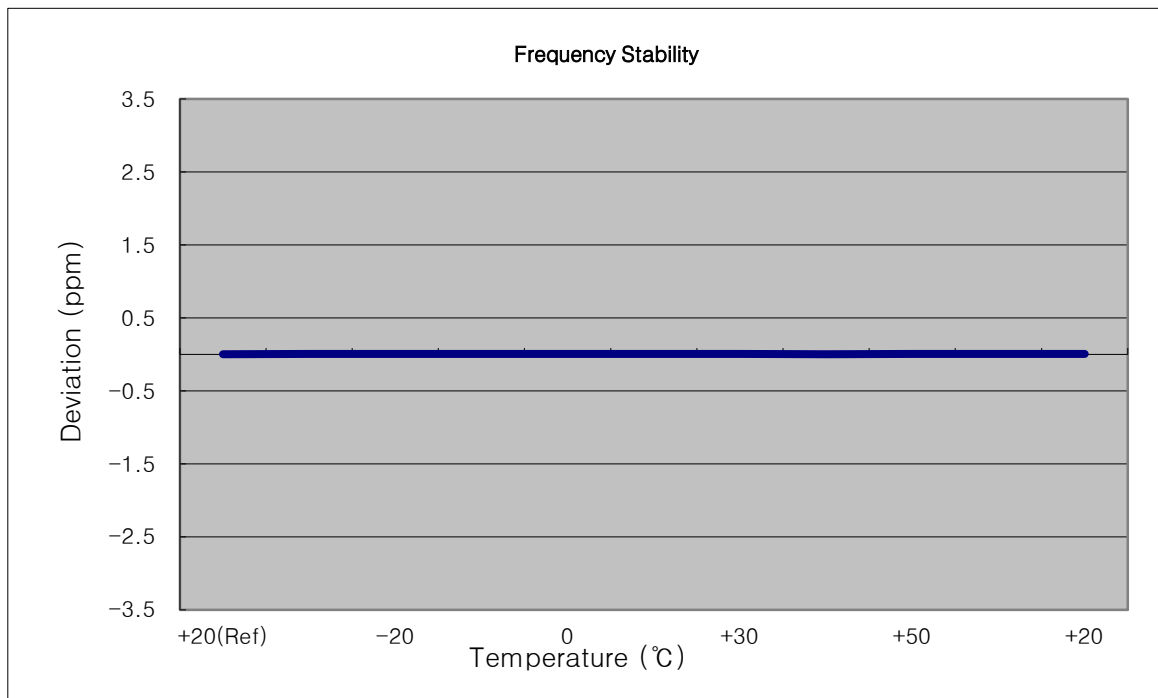

- ▣ OPERATING FREQUENCY: 1732,500,000 Hz
- ▣ CHANNEL: 20175 (15 MHz)
- ▣ REFERENCE VOLTAGE: 3.8 VDC
- ▣ DEVIATION LIMIT: -

Voltage (%)	Power (VDC)	Temp. (°C)	Frequency (Hz)	Frequency Error (Hz)	Deviation (%)	ppm
100%	3.80	+20(Ref)	1732 499 991	0	0.000 000	0.000
100%		-30	1732 499 997	6.20	0.000 000	0.004
100%		-20	1732 500 001	10.00	0.000 001	0.006
100%		-10	1732 499 999	8.20	0.000 000	0.005
100%		0	1732 500 000	9.30	0.000 001	0.005
100%		+10	1732 500 001	10.50	0.000 001	0.006
100%		+30	1732 499 998	6.60	0.000 000	0.004
100%		+40	1732 500 000	8.90	0.000 001	0.005
100%		+50	1732 499 998	7.50	0.000 000	0.004
115%	4.37	+20	1732 499 980	-10.70	-0.000 001	-0.006
Batt. Endpoint	3.23	+20	1732 500 000	9.00	0.000 001	0.005

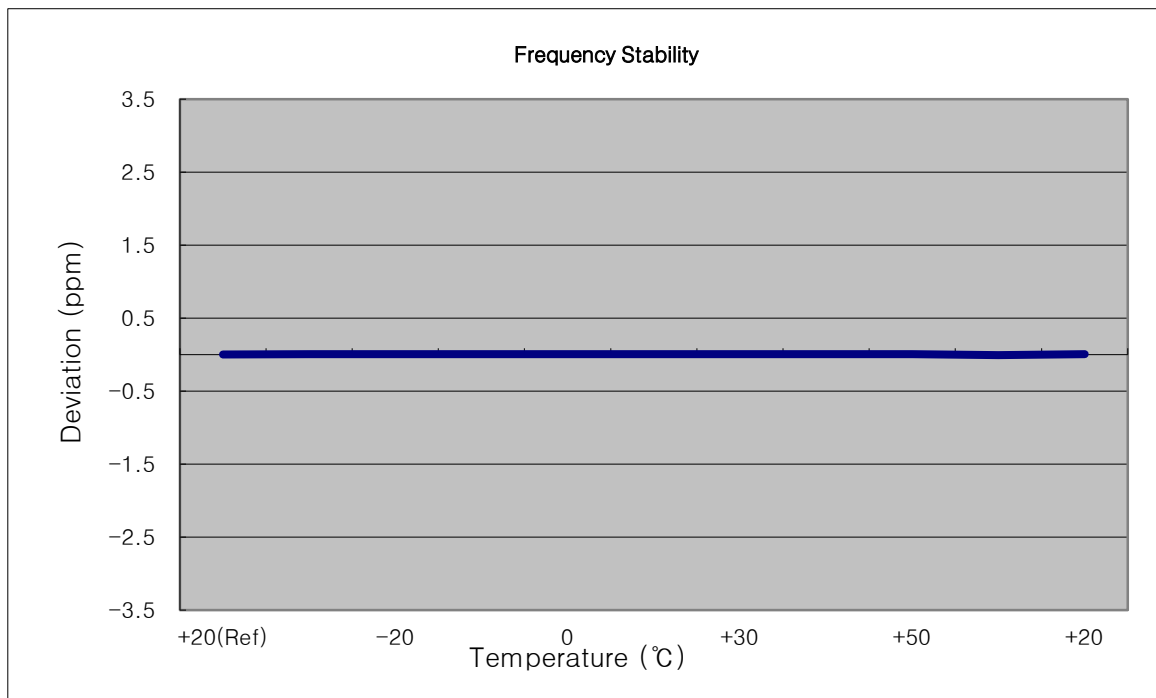

- OPERATING FREQUENCY: 1732,500,000 Hz
- CHANNEL: 20175 (20 MHz)
- REFERENCE VOLTAGE: 3.8 VDC
- DEVIATION LIMIT: -

Voltage (%)	Power (VDC)	Temp. (°C)	Frequency (Hz)	Frequency Error (Hz)	Deviation (%)	ppm
100%	3.80	+20(Ref)	1732 499 990	0	0.000 000	0.000
100%		-30	1732 500 002	12.10	0.000 001	0.007
100%		-20	1732 499 997	6.90	0.000 000	0.004
100%		-10	1732 499 994	4.30	0.000 000	0.002
100%		0	1732 499 998	8.00	0.000 000	0.005
100%		+10	1732 499 997	7.30	0.000 000	0.004
100%		+30	1732 499 996	6.10	0.000 000	0.004
100%		+40	1732 499 999	8.80	0.000 001	0.005
100%		+50	1732 500 001	11.10	0.000 001	0.006
115%	4.37	+20	1732 499 983	-7.10	0.000 000	-0.004
Batt. Endpoint	3.23	+20	1732 499 986	-3.50	0.000 000	-0.002

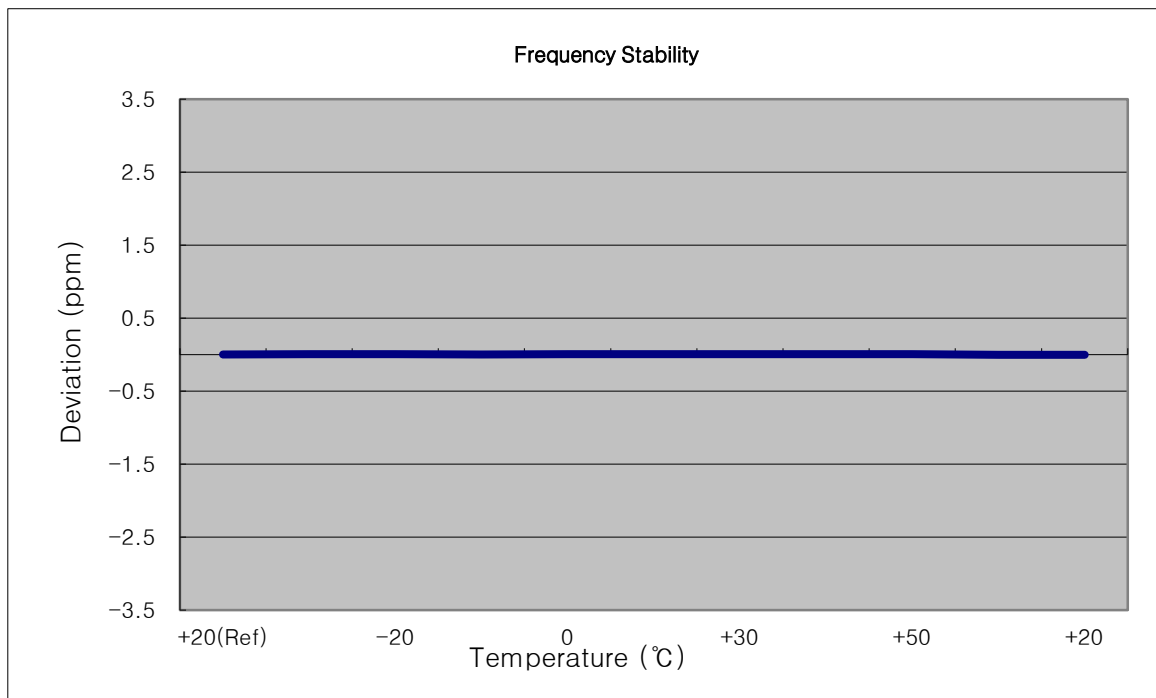

8. TEST PLOTS

BAND 17. Occupied Bandwidth Plot (23790ch_5MHz_QPSK_RB 25)

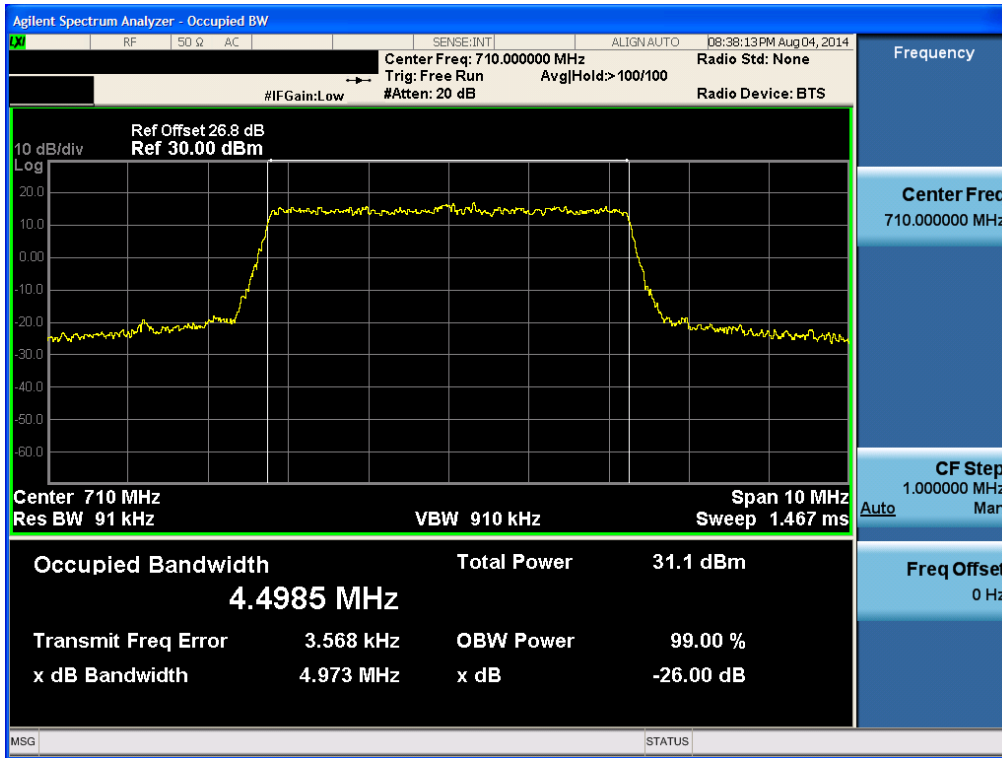

BAND 17. Occupied Bandwidth Plot (23790ch_5MHz_16-QAM_RB 25)

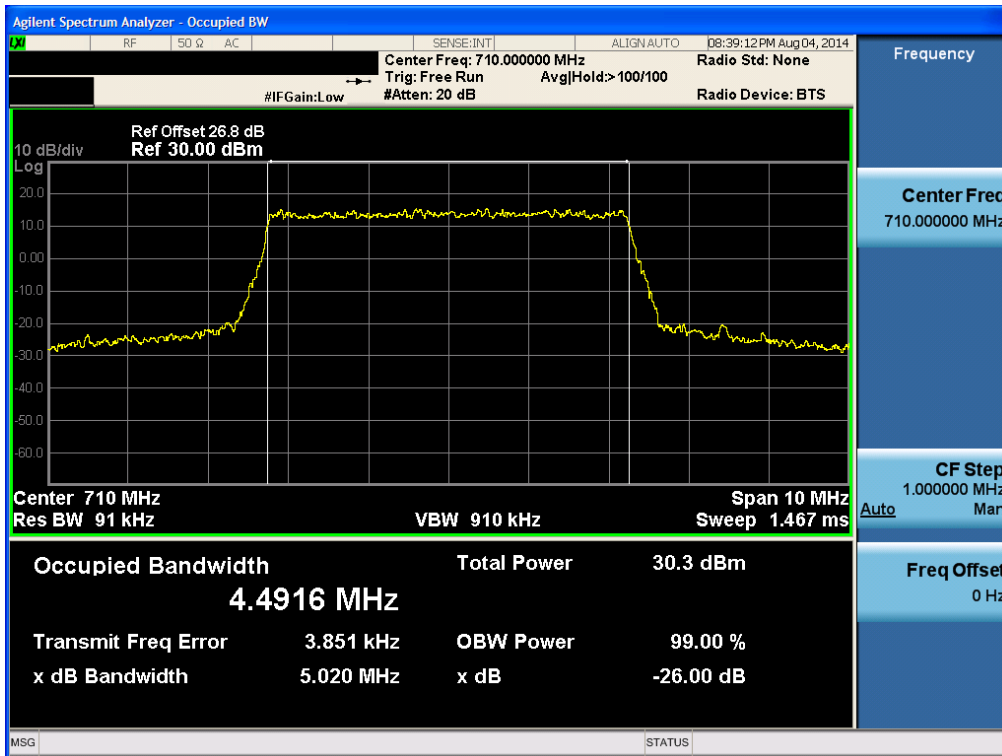

BAND 17. Occupied Bandwidth Plot (23790ch_10MHz_QPSK_RB 50)

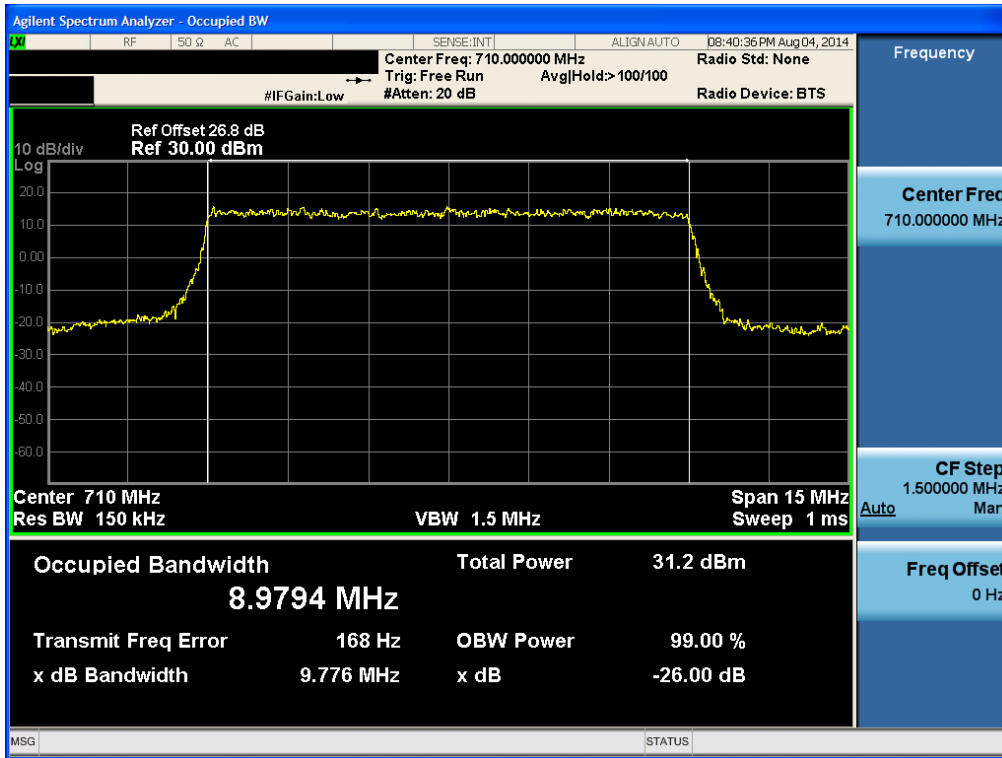

BAND 17. Occupied Bandwidth Plot (23790ch_10MHz_16-QAM_RB 50)

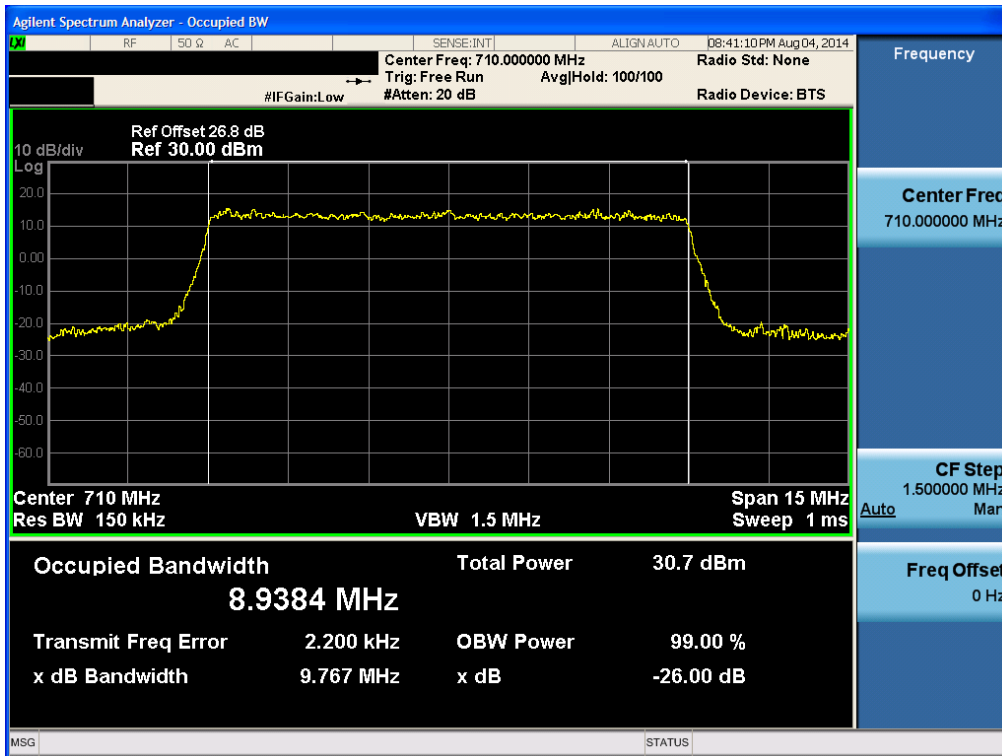

BAND 4. Occupied Bandwidth Plot (1.4M BW Ch.20175 QPSK RB 6)

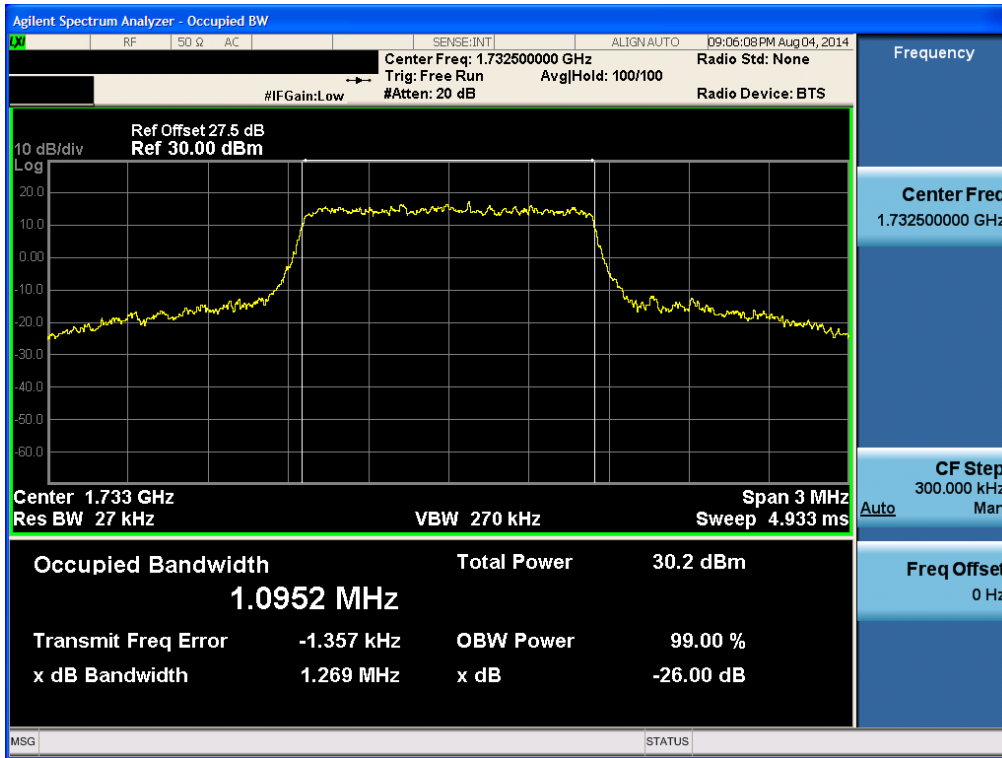

BAND 4. Occupied Bandwidth Plot (1.4M BW Ch.20175 16QAM RB 6)

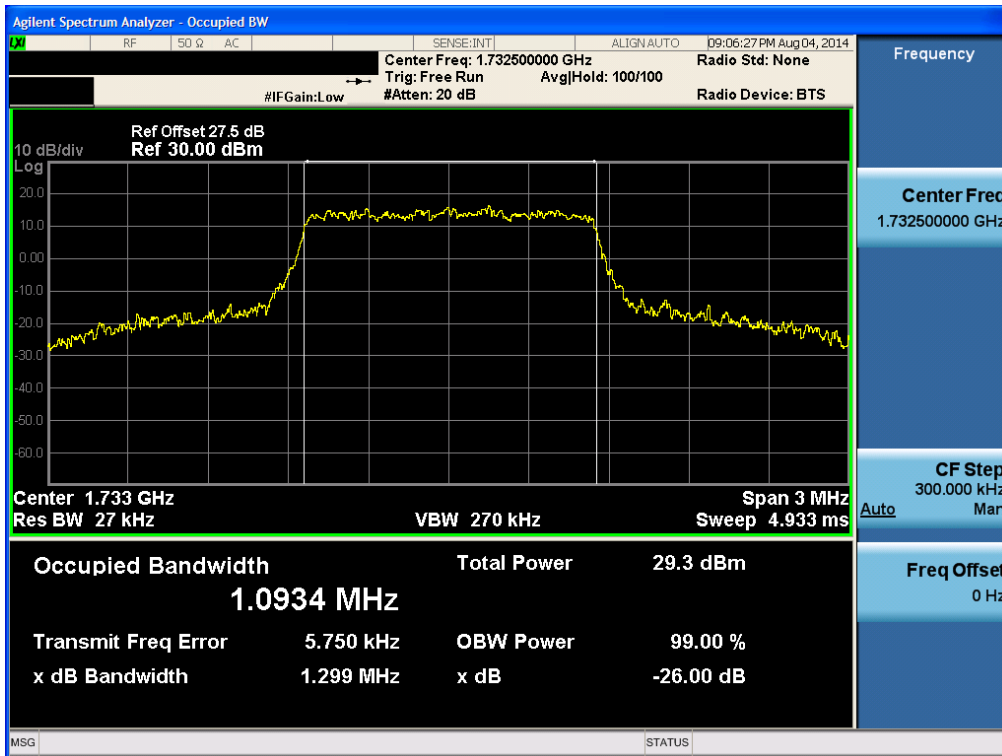

BAND 4. Occupied Bandwidth Plot (3M BW Ch.20175 QPSK RB 15)

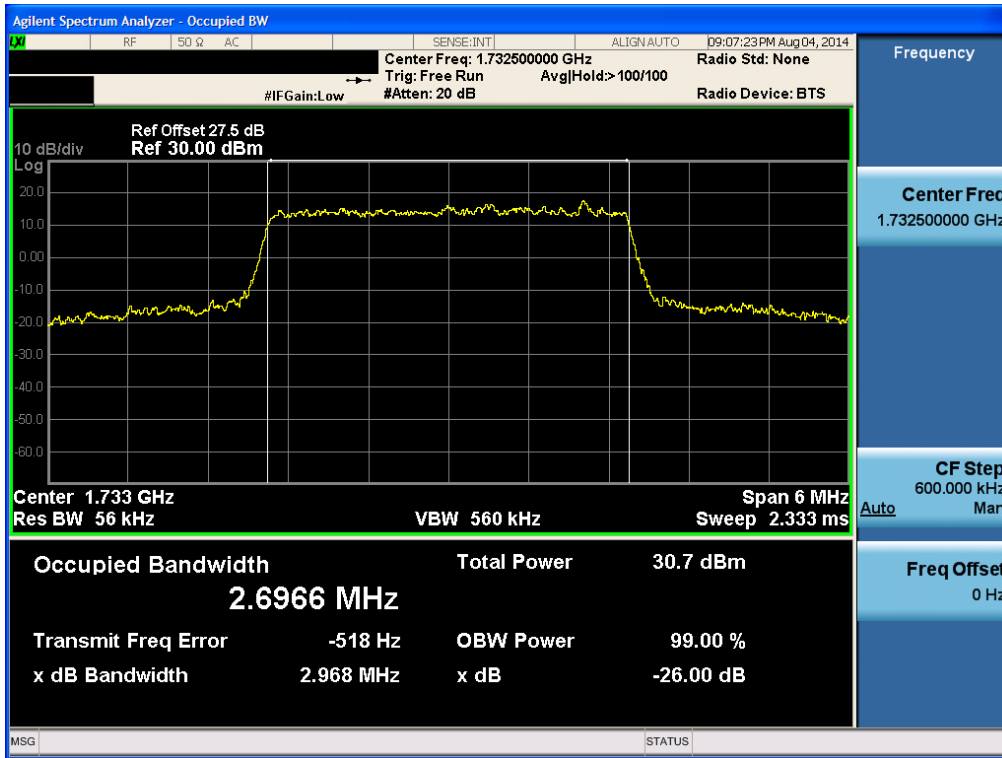

BAND 4. Occupied Bandwidth Plot (3M BW Ch.20175 16QAM RB 15)

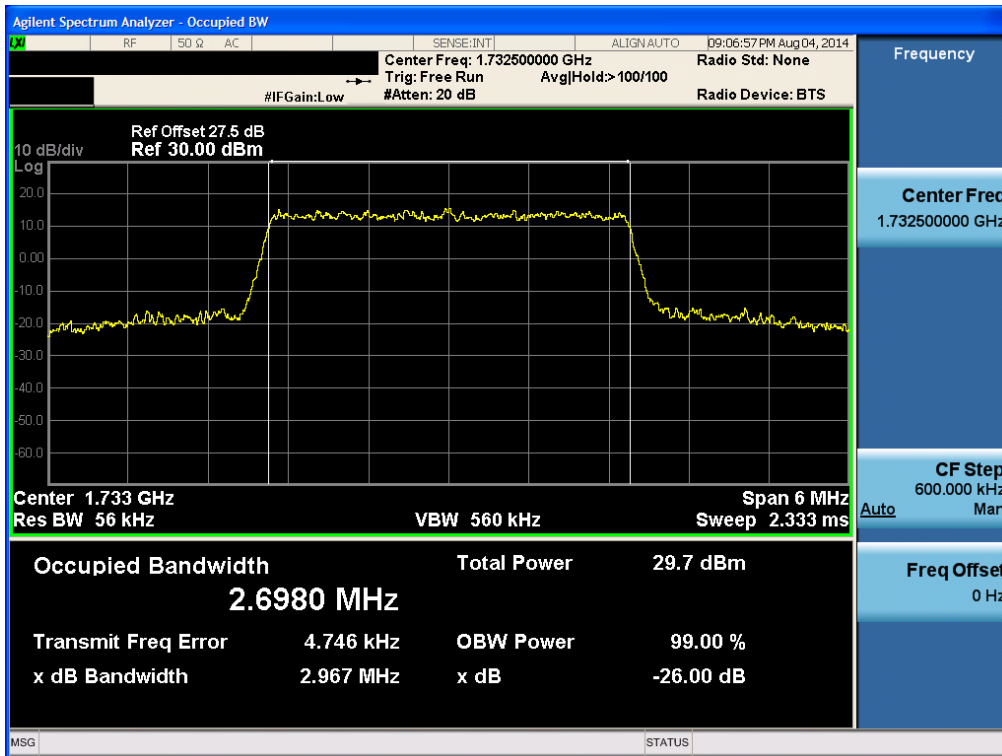

BAND 4. Occupied Bandwidth Plot (5M BW Ch.20175 QPSK RB 25)

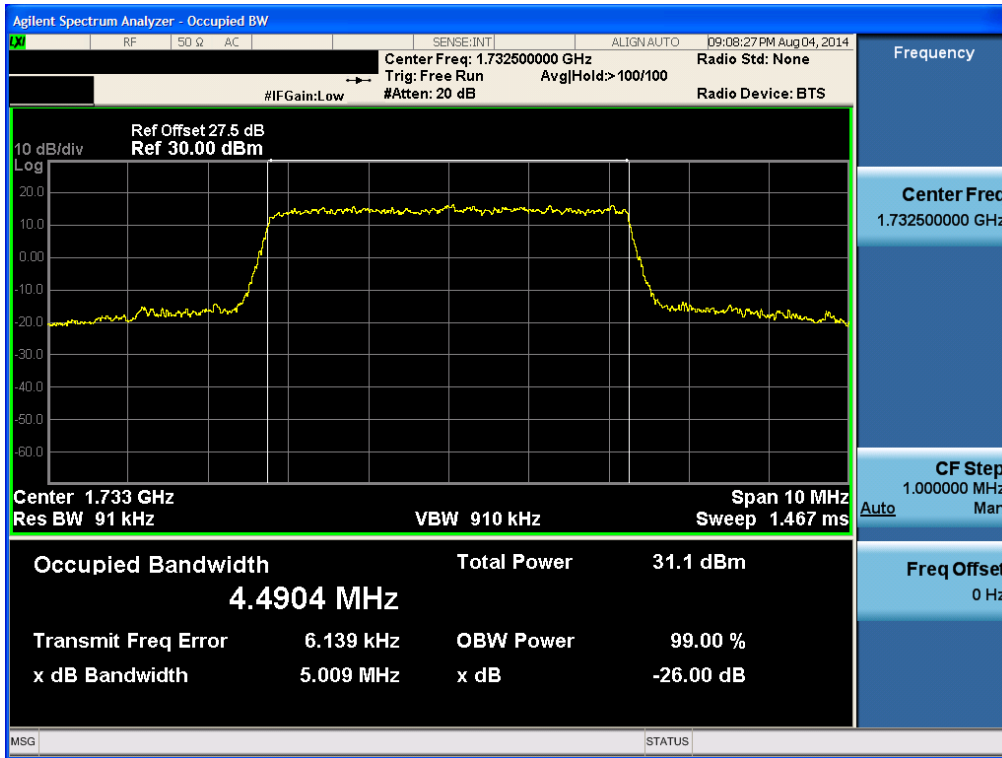

BAND 4. Occupied Bandwidth Plot (5M BW Ch.20175 16QAM RB 25)

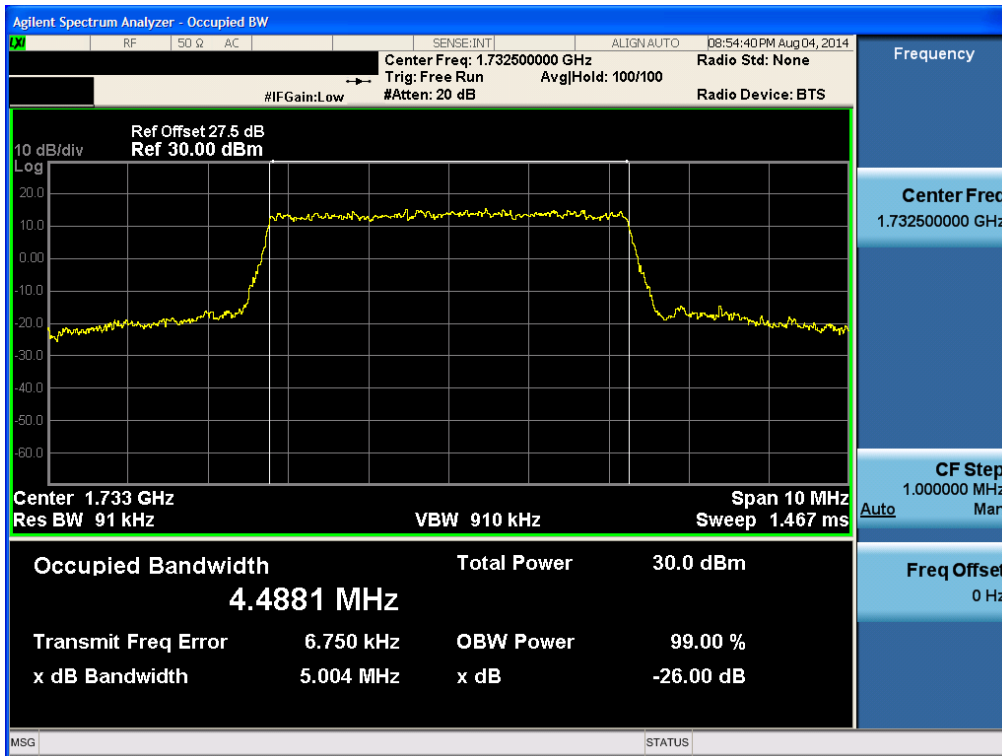

BAND 4. Occupied Bandwidth Plot (10M BW Ch.20175 QPSK RB 50)

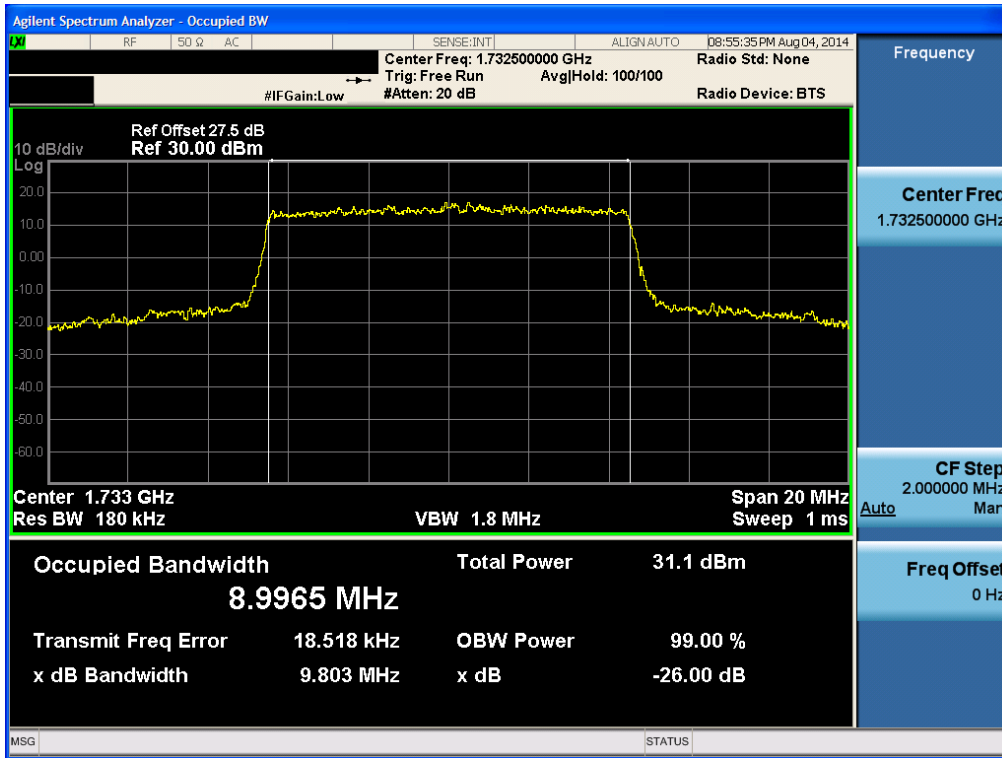

BAND 4. Occupied Bandwidth Plot (10M BW Ch.20175 16QAM RB 50)

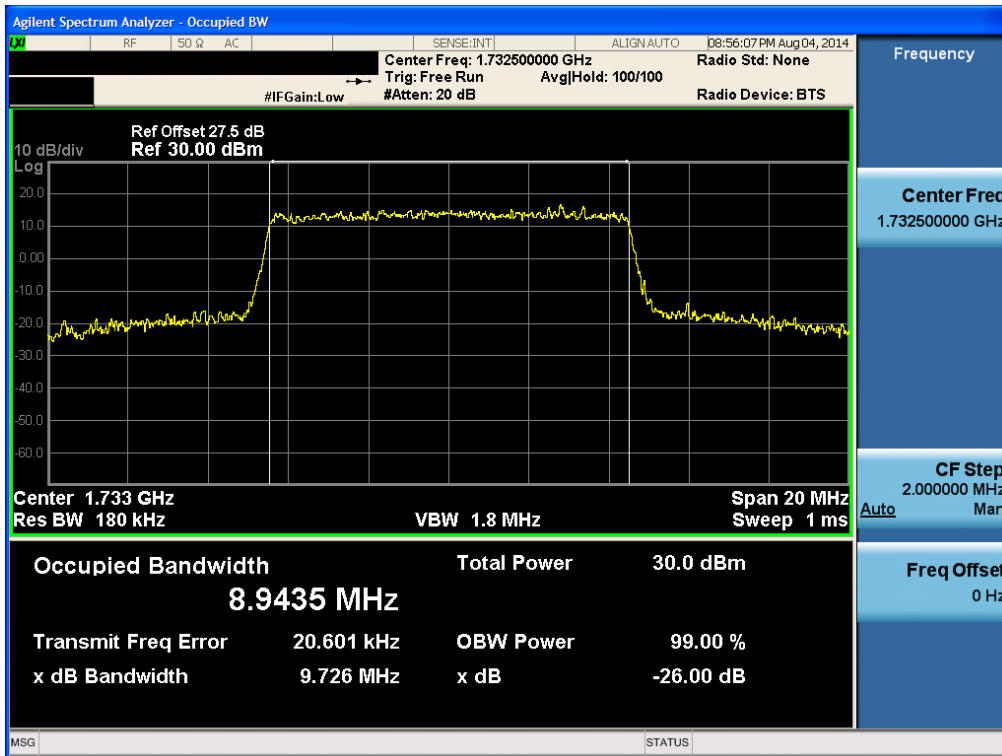

BAND 4. Occupied Bandwidth Plot (15M BW Ch.20175 QPSK RB 75)

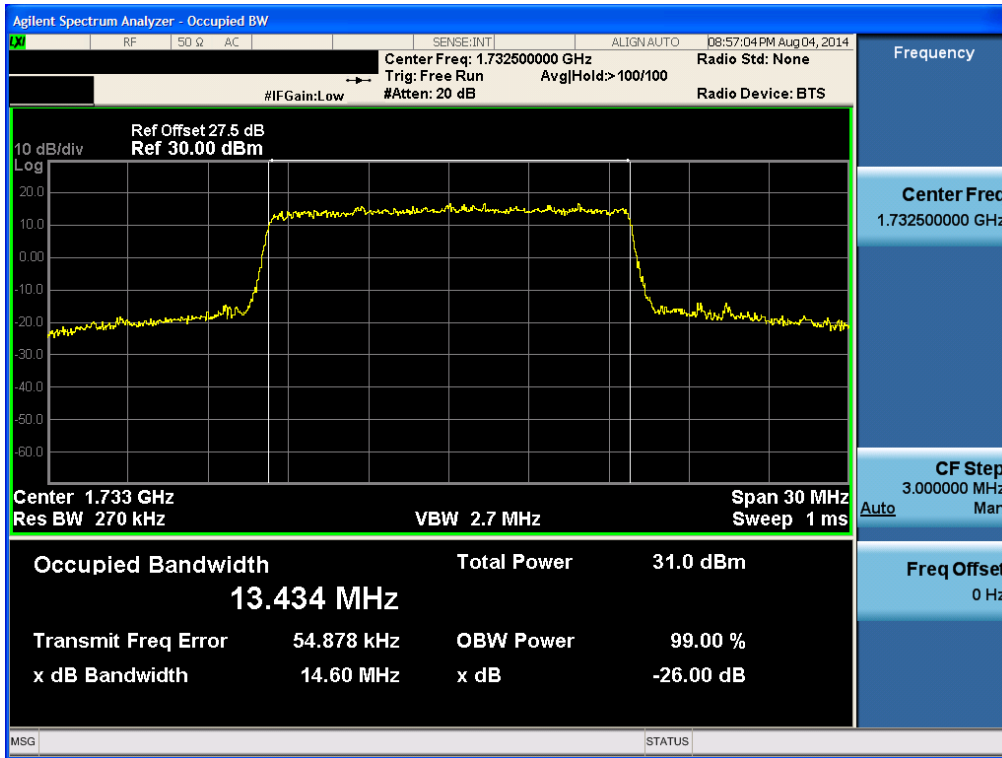

BAND 4. Occupied Bandwidth Plot (15M BW Ch.20175 16QAM RB 75)

