

RF TEST REPORT

Test item : Cellular/PCS GSM/GPRS/EDGE and
PCS WCDMA/HSDPA/HSUPA Phone with Bluetooth and WLAN
Model No. : LG-D160j, LG-D160J, D160j, D160J, LGD160j, LGD160J
Order No. : DEMC1401-00479
Date of receipt : 2014-02-10
Test duration : 2014-02-19 ~ 2014-02-24, 2014-03-08 ~ 2014-03-10
Date of issue : 2014-03-11
Use of report : FCC Original Grant

Applicant : LG Electronics MobileComm U.S.A., Inc.
1000 Sylvan Avenue, Englewood Cliffs NJ 07632

Test laboratory : Digital EMC Co., Ltd.
42, Yurim-ro, 154beon-gil, Cheoin-gu, Yongin-si, Gyeonggi-do, Korea 449-935

Test specification : §22(H), §24(E)
Test environment : See appended test report
Test result : Pass Fail

The test results presented in this test report are limited only to the sample supplied by applicant and the use of this test report is inhibited other than its purpose. This test report shall not be reproduced except in full, without the written approval of DIGITAL EMC CO., LTD.

Tested by:



Engineer
JaeJin Lee

Reviewed by:



General Manager
Geunki Son

Test Report Version

Test Report No.	Date	Description
DRTFCC1402-0287	Feb. 26, 2014	Initial issue
DRTFCC1403-0287(1)	Mar. 11, 2014	Retest ERP, EIRP, Radiated Spurious Emissions

Table of Contents

1. GENERAL INFORMATION	4
2. INTRODUCTION	5
2.1. EUT DESCRIPTION	5
2.2. MEASURING INSTRUMENT CALIBRATION.....	5
2.3. TEST FACILITY	5
3. DESCRIPTION OF TESTS.....	6
3.1 ERP&EIRP	6
3.2 PEAK TO AVERAGE RATIO.....	8
3.3 OCCUPIED BANDWIDTH.....	10
3.4 SPURIOUS AND HARMONIC EMISSIONS AT ANTENNA TERMINAL.....	11
3.5 RADIATED SPURIOUS EMISSIONS	12
3.6 FREQUENCY STABILITY / VARIATION OF AMBIENT TEMPERATURE	13
4. LIST OF TEST EQUIPMENT.....	14
5. SUMMARY OF TEST RESULTS	15
6. SAMPLE CALCULATION	16
7. TEST DATA	17
7.1 CONDUCTED OUTPUT POWER.....	17
7.2 PEAK TO AVERAGE RATIO.....	18
7.3 OCCUPIED BANDWIDTH.....	18
7.4 SPURIOUS AND HARMONIC EMISSIONS AT ANTENNA TERMINAL.....	18
7.5 BAND EDGE.....	18
7.6 EFFECTIVE RADIATED POWER.....	19
7.7 EQUIVALENT ISOTROPIC RADIATED POWER	20
7.8 RADIATED SPURIOUS EMISSIONS	21
7.8.1 RADIATED SPURIOUS EMISSIONS (GSM850)	21
7.8.2 RADIATED SPURIOUS EMISSIONS (GSM1900)	22
7.8.3 RADIATED SPURIOUS EMISSIONS (WCDMA1900).....	23
7.8.4 RADIATED SPURIOUS EMISSIONS (HSUPA1900)	24
7.9 FREQUENCY STABILITY / VARIATION OF AMBIENT TEMPERATURE	25
7.9.1 FREQUENCY STABILITY (GSM850)	25
7.9.2 FREQUENCY STABILITY (GSM1900)	26
7.9.3 FREQUENCY STABILITY (WCDMA1900).....	27
7.9.4 FREQUENCY STABILITY (HSUPA1900)	28
8. TEST PLOTS	29
8.1 Peak to Average Ratio.....	29
8.2 Occupied Bandwidth 99 % Bandwidth	32
8.3 Spurious Emissions at Antenna Terminal	44
8.4 Band Edge	55

1. GENERAL INFORMATION

Applicant Name: LG Electronics MobileComm U.S.A., Inc.

Address: 1000 Sylvan Avenue, Englewood Cliffs NJ 07632

FCC ID : ZNFD160J

FCC Classification : Licensed Portable Transmitter Held to Ear (PCE)

EUT : Cellular/PCS GSM/GPRS/EDGE and PCS WCDMA/HSDPA/HSUPA Phone with Bluetooth and WLAN

Model Name : LG-D160j

Add Model Name : LG-D160J, D160j, D160J, LGD160j, LGD160J
※ 6 models are same mechanical, electrical and functional.
※ The only difference is the model name, which are changed for marketing purpose.

Supplying power : Standard Battery
- Type: Li-ion Battery
- M/N: BL-44JR
- Rating: DC 3.7 V & 1540 mAh / 5.7 Wh

Antenna Information : Internal Antenna
- Type: Built-In type

Tx Frequency : GSM850: 824.2 ~ 848.8 MHz
GSM1900: 1850.2 ~ 1909.8 MHz
EDGE850: 824.2 ~ 848.8 MHz
EDGE1900: 1850.2 ~ 1909.8 MHz
WCDMA1900: 1852.4 ~ 1907.6 MHz
HSUPA1900: 1852.4 ~ 1907.6 MHz

Rx Frequency : GSM850: 869.2 ~ 893.8 MHz
GSM1900: 1930.2 ~ 1989.8 MHz
EDGE850: 869.2 ~ 893.8 MHz
EDGE1900: 1930.2 ~ 1989.8 MHz
WCDMA1900: 1932.4 ~ 1987.6 MHz
HSUPA1900: 1932.4 ~ 1987.6 MHz

Max. RF Output Power : GSM850: 1.641 W ERP(32.15 dBm)
GSM1900: 0.834 W EIRP(29.21 dBm)
EDGE850: 0.532 W ERP(27.26 dBm)
EDGE1900: 0.251 W EIRP(23.99 dBm)
WCDMA1900: 0.168 W EIRP(22.26 dBm)
HSUPA1900: 0.144 W EIRP(21.57 dBm)

Emission Designator(s) : GSM850: 245KGXW
GSM1900: 244KGXW
EDGE850: 254KG7W
EDGE1900: 244KG7W
WCDMA1900: 4M20F9W
HSUPA1900: 4M18F9W

2. INTRODUCTION

2.1. EUT DESCRIPTION

The Equipment Under Test (EUT) supports a Cellular/PCS band(GSM/GPRS/EDGE) and PCS band (WCDMA/HSDPA/HSUPA) phone with Bluetooth and WLAN.

2.2. MEASURING INSTRUMENT CALIBRATION

The measuring equipment, which was utilized in performing the tests documented herein, has been calibrated in accordance with the manufacturer's recommendations for utilizing calibration equipment, which is traceable to recognized national standards.

2.3. TEST FACILITY

The 3 & 10m test site and conducted measurement facility used to collect the radiated data are located at the 38, Yurim-ro, 154 beon-gil, Cheoin-gu, Yongin-si, Gyeonggi-do, Korea 449-935. The site is constructed in conformance with the requirements.

- 3 &10m test site registration Number: 678747

3. DESCRIPTION OF TESTS

3.1 ERP&EIRP (Effective Radiated Power & Equivalent Isotropic Radiated Power)

Test Set-up

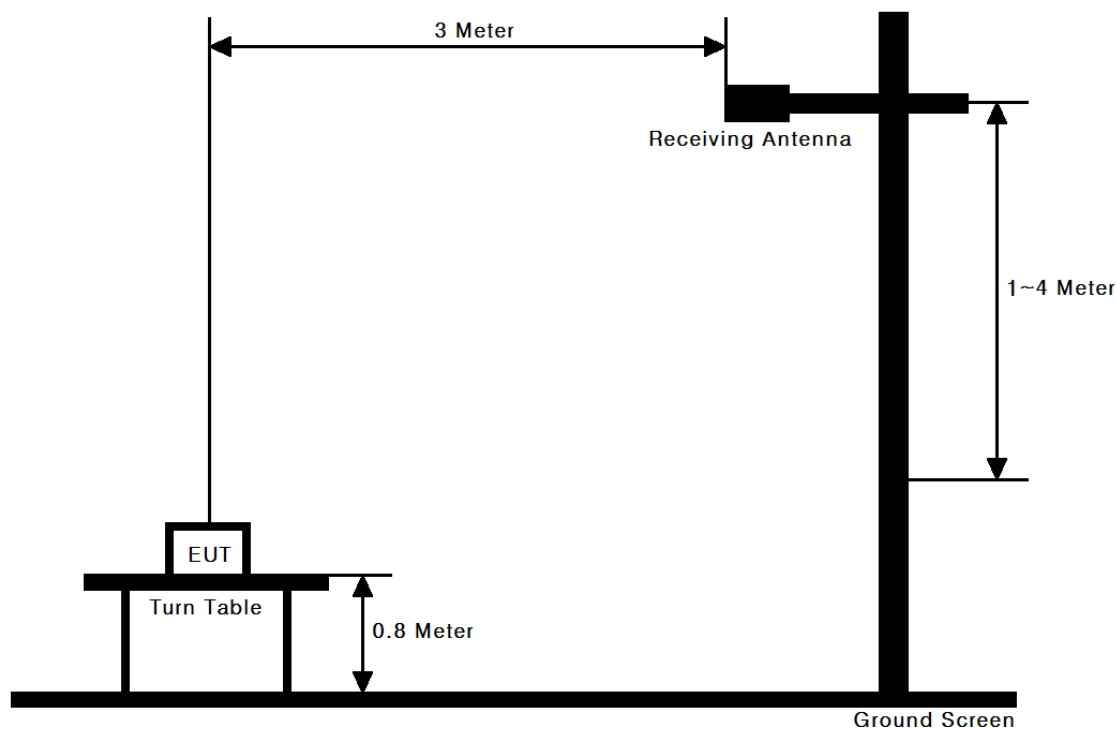

These measurements were performed at 3 & 10m test site. The equipment under test is placed on a wooden turntable 0.8-meters above the ground plane and 3-meters from the receive antenna. The receive antenna height and turntable rotations were adjusted for the highest reading on the receive spectrum analyzer.

A half-wave dipole was substituted in place of the EUT. This dipole antenna was driven by a signal generator and the level of the signal generator was adjusted to obtain the same receive spectrum analyzer reading.

For readings above 1GHz, the above procedure is repeated using horn antennas and the difference between the gain of the horn and an isotropic antenna are taken into consideration.

Test Procedure

- **ANSI/TIA-603-C-2004 - Section 2.2.17**
- **KDB971168 v02r01- Section 5.2.1**

1. Set span to at least 1.5 times the OBW.
2. Set RBW = 1-5% of the OBW, not to exceed 1 MHz.
3. Set VBW $\geq 3 \times$ RBW.
4. Set number of points in sweep $\geq 2 \times$ span / RBW.
5. Sweep time = auto-couple.
6. Detector = RMS (power averaging).
7. If the EUT can be configured to transmit continuously (i.e., burst duty cycle $\geq 98\%$), then set the trigger to free run.
8. If the EUT cannot be configured to transmit continuously (i.e., burst duty cycle $< 98\%$), then use a sweep trigger with the level set to enable triggering only on full power bursts and configure the EUT to transmit at full power for the entire duration of each sweep. Ensure that the sweep time is less than or equal to the transmission burst duration.
9. Trace average at least 100 traces in power averaging (i.e., RMS) mode.
10. Compute the power by integrating the spectrum across the OBW of the signal using the instrument's band power measurement function, with the band limits set equal to the OBW band edges. If the instrument does not have a band power function, then sum the spectrum levels (in linear power units) at intervals equal to the RBW extending across the entire OBW of the spectrum.

3.2 PEAK TO AVERAGE RATIO

Test set-up

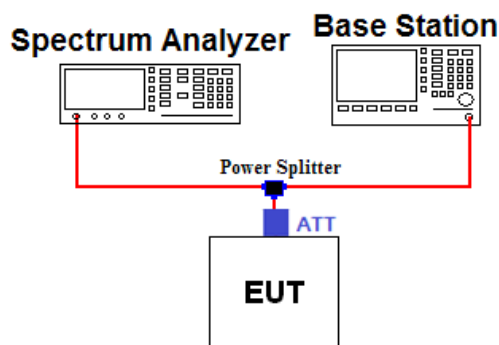

Test Procedure

A peak to average ratio measurement is performed using the following procedure.

■ CCDF Procedure

- KDB971168 v02r01-Section 5.7.1

1. Set resolution/measurement bandwidth \geq signal's occupied bandwidth
2. Set the number of counts to a value that stabilizes the measured CCDF curve
3. Set the measurement interval as follows:
 - 1) For continuous transmissions, set to 1 ms
 - 2) For burst transmissions, employ an external trigger that is synchronized with the EUT burst timing sequence, or use the internal burst trigger with a trigger level that allows the burst to stabilize and set the measurement interval to a time that is less than or equal to the burst duration.
4. Record the maximum PAPR level associated with a probability of 0.1%

■ Alternate Procedure**- KDB971168 v02r01-Section 5.7.2**

Use one of the measurement procedures of the peak power and record as P_{Pk} .

Use one of the measurement procedures of the average power and record as P_{Avg} .

Both the peak and average power levels must be expressed in the same logarithmic units (e.g., dBm). Determine the PAPR from:

$$\text{PAPR (dB)} = P_{Pk} \text{ (dBm)} - P_{Avg} \text{ (dBm)}.$$

- Peak Power Measurement

1. Set the RBW \geq OBW
2. Set VBW $\geq 3 \times$ RBW
3. Set span $\geq 2 \times$ RBW
4. Sweep time = auto couple
5. Detector = peak
6. Ensure that the number of measurement points \geq span/RBW.
7. Trace mode = max hold
8. Allow trace to fully stabilize.
9. Use the peak marker function to determine the peak amplitude level.

- Average Power Measurement

1. Set span to at least 1.5 times the OBW.
2. Set RBW = 1-5% of the OBW, not to exceed 1 MHz.
3. Set VBW $\geq 3 \times$ RBW.
4. Set number of points in sweep $\geq 2 \times$ span / RBW.
5. Sweep time = auto-couple.
6. Detector = RMS (power averaging).
7. If the EUT can be configured to transmit continuously (i.e., burst duty cycle $\geq 98\%$), then set the trigger to free run.
8. If the EUT cannot be configured to transmit continuously (i.e., burst duty cycle $< 98\%$), then use a sweep trigger with the level set to enable triggering only on full power bursts and configure the EUT to transmit at full power for the entire duration of each sweep. Ensure that the sweep time is less than or equal to the transmission burst duration.
9. Trace average at least 100 traces in power averaging (i.e., RMS) mode.
10. Compute the power by integrating the spectrum across the OBW of the signal using the instrument's band power measurement function, with the band limits set equal to the OBW band edges. If the instrument does not have a band power function, then sum the spectrum levels (in linear power units) at intervals equal to the RBW extending across the entire OBW of the spectrum.

3.3 OCCUPIED BANDWIDTH.

Test set-up

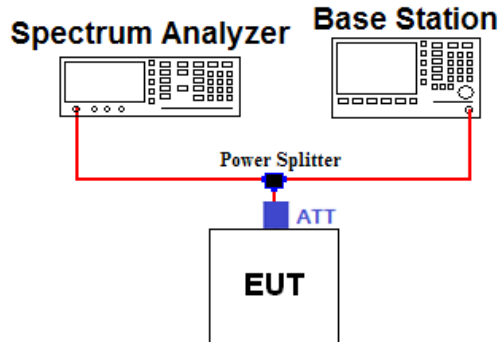

Offset value information

Frequency (MHz)	Offset Value (dB)	Frequency (MHz)	Offset Value (dB)
824.2	19.12	1850.2	19.57
836.6	19.16	1852.4	19.57
848.8	19.20	1880.0	19.64
-	-	1907.6	19.66
-	-	1909.8	19.66
-	-	-	-

Note. 1: The offset values from EUT to Spectrum analyzer were measured and used for test.
 Offset value = Cable A + Splitter + ATT + Cable B

Test Procedure

- KDB971168 v02r01-Section 4.2

The occupied bandwidth, that is the frequency bandwidth such that, below its lower and above its upper frequency limits, the mean powers radiated are each equal to 0.5 percent of the total mean power of a given emission.

1. The signal analyzer`s automatic bandwidth measurement capability was used to perform the 99% occupied bandwidth and the 26dB bandwidth. The bandwidth measurement was not influenced by any intermediate power nulls in the fundamental emission.
2. RBW = 1 ~ 5% of the expected OBW
3. VBW ≥ 3 X RBW
4. Detector = Peak
5. Trance mode = Max hold
6. Sweep = Auto couple
7. The trace was allowed to stabilize
8. If necessary, step 2 ~ 7 were repeated after changing the RBW such that it would be within 1 ~ 5% of the 99% occupied bandwidth observed in step 7.

3.4 SPURIOUS AND HARMONIC EMISSIONS AT ANTENNA TERMINAL.

Test set-up

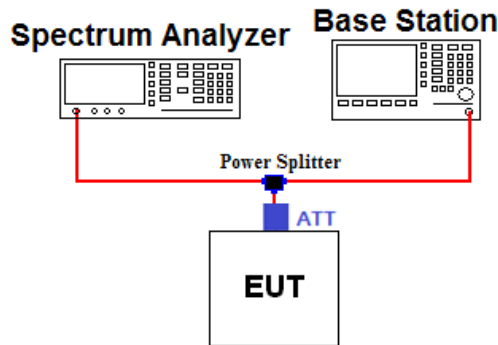

Offset value information

Frequency (MHz)	Offset Value (dB)	Frequency (MHz)	Offset Value (dB)	Frequency (MHz)	Offset Value (dB)
824.0	19.12	1847.0	19.56	5000.0	20.84
849.0	19.21	1850.0	19.56	10000.0	21.49
-	-	1910.0	19.67	15000.0	21.90
-	-	1913.0	19.67	20000.0	22.88

Note. 1: The offset value from EUT to Spectrum analyzer was measured and used for test.
 Offset value = Cable A + Splitter + ATT + Cable B

Test Procedure

- KDB971168 v02r01 - Section 6.0

The level of the carrier and the various conducted spurious and harmonic frequencies is measured by means of a calibrated spectrum analyzer.

The EUT was setup to maximum output power at its lowest channel. The spectrum is scanned from the lowest frequency generated in the equipment up to a frequency including its 10th harmonic.

1. RBW = 1MHz & VBW ≥ 3MHz
2. Detector = Positive peak
3. Trace mode = Max hold
4. Sweep time = Auto
5. The trace was allowed to stabilize

The highest, lowest and a middle channel were tested for out of band measurements. The minimum permissible attenuation level of any spurious emission is $43 + \log_{10}(P[\text{Watts}])$, where P is the transmitter power in Watts.

Note 1: In the 1MHz bands immediately outside and adjacent to the frequency block, a resolution bandwidth of at least 1 percent of the emission bandwidth of the fundamental emission of the transmitter was employed to measure the out of band Emissions.

Note 2: Compliance with the applicable limits is based on the use of measurement instrumentation employing a RBW of 100 KHz or greater for Part 22 and 1 MHz or greater for Part 24.

3.5 RADIATED SPURIOUS EMISSIONS

Test Set-up

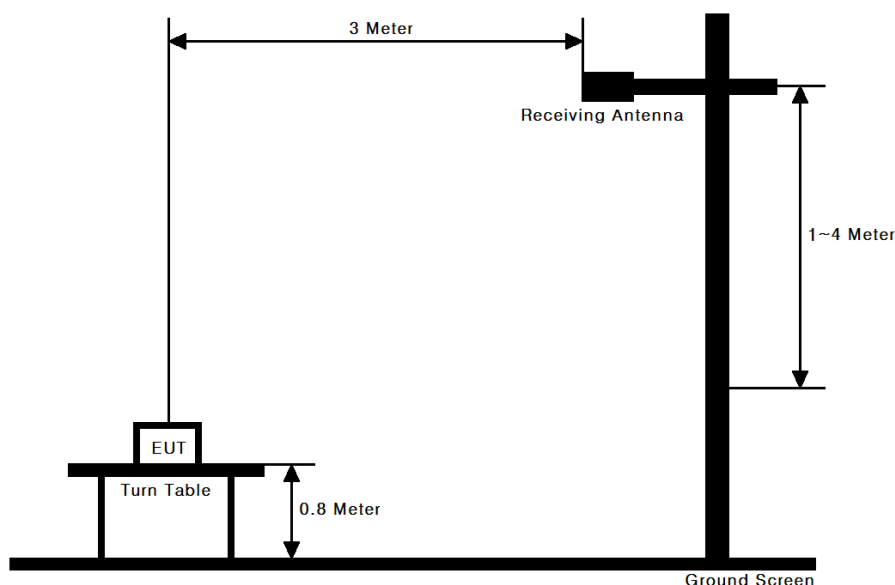

Test Procedure

- ANSI/TIA-603-C-2004 - Section 2.2.12
- KDB971168 v02r01 - Section 5.8

This measurement was performed at 3-meter test range. The equipment under test is placed on a wooden turntable 0.8-meters above the ground plane and 3-meters from the receive antenna.

The receive antenna height and turntable rotations were adjusted for the highest reading on the receive spectrum analyzer.

For radiated power measurements below 1GHz, a half-wave dipole was substituted in place of the EUT. This dipole antenna was driven by a signal generator and the level of the signal generator was adjusted to obtain the same spectrum analyzer reading.

For radiated power measurements above 1GHz, a Horn antenna was substituted in place of the EUT. This Horn antenna was driven by a signal generator and the level of the signal generator was adjusted to obtain the same spectrum analyzer reading. The difference between the gain of the horn and an isotropic antenna are taken into consideration.

This measurement was performed with the EUT oriented in 3 orthogonal axis.

3.6 FREQUENCY STABILITY / VARIATION OF AMBIENT TEMPERATURE

Test Set-up

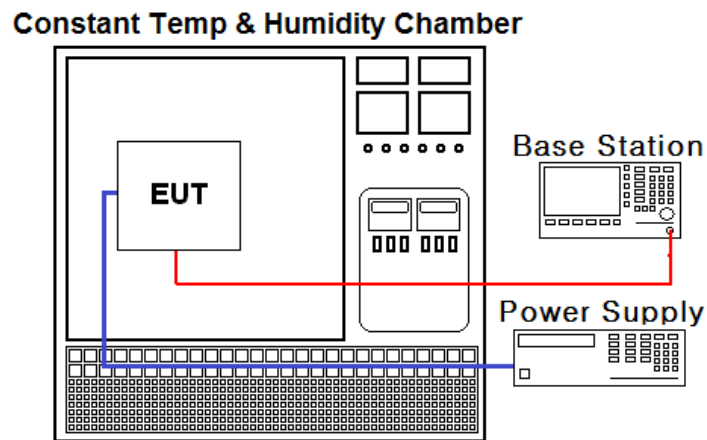

Test Procedure

- ANSI/TIA-603-C-2004

The frequency stability of the transmitter is measured by:

- a.) **Temperature:** The temperature is varied from - 30 °C to + 50 °C using an environmental chamber.
- b.) **Primary Supply Voltage:** The primary supply voltage is varied from battery end point to 115 % of the voltage normally at the input to the device or at the power supply terminals if cables are not normally supplied.

Specification - the frequency stability shall be sufficient to ensure that the fundamental emission stays within the authorized frequency block. The frequency stability of the transmitter shall be maintained within $\pm 0.00025\%$ (± 2.5 ppm) of the center frequency.

Time Period and Procedure:

1. The carrier frequency of the transmitter is measured at room temperature. (25°C to provide a reference).
2. The equipment is turned on in a "standby" condition for one minute before applying power to the transmitter. Measurement of the carrier frequency of the transmitter is made within one minute after applying power to the transmitter.
3. Frequency measurements are made at 10°C intervals ranging from -30°C to +50°C. A period of at least one half-hour is provided to allow stabilization of the equipment at each temperature level.

NOTE: The EUT is tested down to the battery endpoint.

4. LIST OF TEST EQUIPMENT

Type	Manufacturer	Model	Cal.Date (yy/mm/dd)	Next.Cal. Date (yy/mm/dd)	S/N
Spectrum Analyzer	Agilent	N9030A	13/10/29	14/10/29	MY53310140
Spectrum Analyzer	Agilent	N9020A	13/03/28	14/03/28	MY50510026
Multimeter	H.P	34401A	14/02/27	15/02/27	3146A13475
DC Power Supply	H.P	6622A	14/02/27	15/02/27	3448A03760
Temp & Humi Test Chamber	SJ Science	TEMI2500	13/10/22	14/10/22	SJ-TH-S50-130930
Power Splitter	Anritsu	K241B	13/10/22	14/10/22	1701099
Attenuator(3dB)	SMAJK	SMAJK-2-3	13/10/22	14/10/22	3
Attenuator(10dB)	SMAJK	SMAJK-50-10	13/10/23	14/10/23	2-50-10
Thermo hygrometer	BODYCOM	BJ5478	13/06/01	14/06/01	120612-2
Dipole Antenna	Schwarzbeck	VHA9103	13/10/24	15/10/24	2116
Dipole Antenna	Schwarzbeck	VHA9103	12/03/22	14/03/22	2117
Dipole Antenna	Schwarzbeck	UHA9105	13/10/24	15/10/24	2261
Dipole Antenna	Schwarzbeck	UHA9105	12/03/22	14/03/22	2262
Bilog Antenna	SCHAFFNER	CBL6112B	12/11/06	14/11/06	2737
Horn Antenna	ETS	3117	13/06/14	15/06/14	00140394
HORN ANT	ETS	3115	13/02/28	15/02/28	00021097
HORN ANT	A.H.Systems	SAS-574	13/03/20	15/03/20	154
HORN ANT	A.H.Systems	SAS-574	13/05/27	15/05/27	155
Amplifier (22dB)	H.P	8447E	14/01/07	15/01/07	2945A02865
Amplifier (30dB)	Agilent	8449B	14/02/27	15/02/27	3008A00370
High-pass filter	Wainwright	WHKX1.0	13/09/12	14/09/12	9
High-Pass Filter	Wainwright	WHNX2.1	13/09/12	14/09/12	1
8960 Series 10 Wireless Comms Test Set	Agilent	E5515C	14/02/28	15/02/28	GB43461134
Universal Radio Communication Tester	Rohde Schwarz	CMU200	14/02/28	15/02/28	106760
Vector Signal Generator	Rohde Schwarz	SMJ100A	14/01/07	15/01/07	100148
Signal Generator	Rohde Schwarz	SMF100A	13/07/22	14/07/22	102341
Amplifier	EMPOWER	BBS3Q7ELU	13/09/12	14/09/12	1020

5. SUMMARY OF TEST RESULTS

FCC Part Section(s)	RSS Section(s)	Parameter	Status Note 1
2.1046	RSS-132 (4.4) RSS-133 (4.1)	Conducted Output Power	C
22.913(a) 24.232(c)	RSS-132 (4.4) [SRSP-503(5.1.3)] RSS-133 (6.4) [SRSP-510(5.1.2)]	Effective Radiated Power Equivalent Isotropic Radiated Power	C
22.917(a) 24.238(a) 2.1049	RSS-Gen (4.6.1) RSS-133 (2.3)	Occupied Bandwidth	C
22.917(a) 24.238(a) 2.1051	RSS-132 (4.5.1) RSS-133 (6.5.1)	Band Edge Spurious and Harmonic Emissions at Antenna Terminal	C
24.232(d)	RSS-133 (6.4)	Peak to Average Ratio	C
22.917(a) 24.238(a) 2.1053	RSS-132 (4.5.1) RSS-133 (6.5.1)	Radiated Spurious and Harmonic Emissions	C
22.355 24.235 2.1055	RSS-132 (4.3) RSS-133 (6.3)	Frequency Stability	C
<p>Note 1: C=Comply NC=Not Comply NT=Not Tested NA=Not Applicable</p>			

The sample was tested according to the following specification:
ANSI/TIA/EIA-603-C-2004 and KDB 971168 D01 v02r01

6. SAMPLE CALCULATION

A. Emission Designator

GSM850 Emission Designator

Emission Designator = **245KGXW**
GSM OBW = 245.45 kHz
(Measured at the 99.75 % power bandwidth)
G = Phase Modulation
X = Cases not otherwise covered
W = Combination (Audio/Data)

EDGE850 Emission Designator

Emission Designator = **254KG7W**
GSM OBW = 253.59 kHz
(Measured at the 99.75 % power bandwidth)
G = Phase Modulation
7 = Two or more channels containing
quantized or digital information
W = Combination (Audio/Data)

WCDMA1900 Emission Designator

Emission Designator = **4M20F9W**
WCDMA OBW = 4.1954 MHz
(Measured at the 99.75 % power bandwidth)
F = Frequency Modulation
9 = Composite Digital Information
W = Combination (Audio/Data)

GSM1900 Emission Designator

Emission Designator = **244KGXW**
GSM OBW = 244.43 kHz
(Measured at the 99.75 % power bandwidth)
G = Phase Modulation
X = Cases not otherwise covered
W = Combination (Audio/Data)

EDGE1900 Emission Designator

Emission Designator = **244KG7W**
GSM OBW = 244.34 kHz
(Measured at the 99.75 % power bandwidth)
G = Phase Modulation
7 = Two or more channels containing
quantized or digital information
W = Combination (Audio/Data)

HSUPA1900 Emission Designator

Emission Designator = **4M18F9W**
HSUPA OBW = 4.1808 MHz
(Measured at the 99.75 % power bandwidth)
F = Frequency Modulation
9 = Composite Digital Information
W = Combination (Audio/Data)

7. TEST DATA

7.1 CONDUCTED OUTPUT POWER

A base station simulator was used to establish communication with the EUT. The base station simulator parameters were set to produce the maximum power from the EUT. This device was tested under all configurations and the highest power is reported. Conducted Output Powers of EUT are reported below.

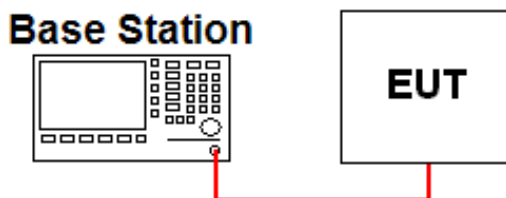

▪ GSM / GPRS / EDGE

Band	Channel	Test Result(dBm)								
		GSM	GPRS 1 TX Slot	GPRS 2 TX Slot	GPRS 3 TX Slot	GPRS 4 TX Slot	EDGE 1 TX Slot	EDGE 2 TX Slot	EDGE 3 TX Slot	EDGE 4 TX Slot
Cellular	128	32.4	32.4	30.4	28.4	27.3	26.4	25.8	24.8	23.8
	190	32.4	32.3	30.4	28.3	27.3	26.3	25.7	24.7	23.7
	251	32.3	32.3	30.4	28.4	27.3	26.3	25.7	24.7	23.7
PCS	512	29.5	29.5	27.4	25.2	24.2	24.7	24.2	23.0	21.9
	661	29.5	29.5	27.4	25.3	24.2	24.7	24.1	23.0	21.9
	810	29.5	29.4	27.4	25.3	24.2	24.7	24.1	23.0	21.9

▪ WCDMA / HSDPA / HSUPA

3GPP Release Version	Mode	3GPP 34.121 Subtest	PCS Band (dBm)			3GPP MPR (dB)
			9262	9400	9538	
99	WCDMA	12.2 kbps RMC	22.93	22.91	22.88	-
99		12.2 kbps AMR	22.91	22.89	22.81	-
5	HSDPA	Subtest 1	21.79	21.75	21.71	0
5		Subtest 2	21.75	21.71	21.66	0
5		Subtest 3	21.11	21.19	21.27	0.5
5		Subtest 4	21.07	21.08	21.23	0.5
6	HSUPA	Subtest 1	21.68	21.67	21.63	0
6		Subtest 2	20.01	20.02	19.91	2
6		Subtest 3	20.79	20.75	20.69	1
6		Subtest 4	19.98	20.01	19.89	2
6		Subtest 5	21.58	21.61	21.55	0

7.2 PEAK TO AVERAGE RATIO

- Plots of the EUT’s Peak- to- Average Ratio are shown in Clause 8.1

7.3 OCCUPIED BANDWIDTH

Band	Channel	Frequency	Test Result (kHz)
GSM850	128	824.2	245.45
	190	836.6	240.38
	251	848.8	241.96
GSM1900	512	1850.2	242.18
	661	1880.0	244.43
	810	1909.8	242.88
EDGE850	128	824.2	237.60
	190	836.6	242.04
	251	848.8	253.59
EDGE1900	512	1850.2	244.34
	661	1880.0	242.33
	810	1909.8	241.93
WCDMA1900	9262	1852.4	4195.4
	9400	1880.0	4184.2
	9538	1907.6	4184.1
HSUPA1900	9262	1852.4	4162.1
	9400	1880.0	4180.8
	9538	1907.6	4169.1

- Plots of the EUT’s Occupied Bandwidth are shown in Clause 8.2

7.4 SPURIOUS AND HARMONIC EMISSIONS AT ANTENNA TERMINAL

- Plots of the EUT’s Conducted Spurious Emissions are shown in Clause 8.3

7.5 BAND EDGE

- Plots of the EUT’s Band Edge are shown in Clause 8.4

7.6 EFFECTIVE RADIATED POWER

- GSM850 data

CH.	EUT Position (Axis)	Test Conditions(Power Step: 5)							
		Reading Value (dBm)	Pol. (H/V)	LEVEL@ TX ANTENNA TERMINAL (dBm)	Antenna Gain (dBd)	ERP (dBm)	ERP (W)	Rated Voltage	Note.
824.2 128 CH	X	-6.56	H	30.16	1.20	31.36	1.368	DC 3.7V	GSM
836.6 190 CH	X	-6.44	H	30.64	1.15	31.79	1.510	DC 3.7V	GSM
848.8 251 CH	X	-5.65	H	31.10	1.05	32.15	1.641	DC 3.7V	GSM
848.8 251 CH	X	-10.54	H	26.21	1.05	27.26	0.532	DC 3.7V	EDGE

NOTES:

This EUT was tested under all configurations and the highest power is reported in GSM mode and WCDMA mode with HSDPA inactive at 12.2 kbps RMC and TPC bits set to "1" and in GSM mode using a Power Control Level of "0" in PCS Band and "5" in the Cellular Band. This EUT was tested with the fully charged battery. Also, we have done x, y, z planes in EUT and horizontal and vertical polarization of detecting antenna.

The worst case data is reported.

7.7 EQUIVALENT ISOTROPIC RADIATED POWER

- GSM1900 data

CH.	EUT Position (Axis)	TEST CONDITIONS(Power Step: 0)							
		Reading Value (dBm)	Pol. (H/V)	LEVEL@ TX ANTENNA TERMINAL (dBm)	Antenna Gain (dBi)	EIRP (dBm)	EIRP (W)	Rated Voltage	Note.
1850.2 512	Y	-10.60	V	24.21	5.00	29.21	0.834	DC 3.7V	GSM
1880.0 661	Z	-10.66	V	24.12	4.94	29.06	0.805	DC 3.7V	GSM
1909.8 810	Z	-11.25	V	23.39	4.88	28.27	0.671	DC 3.7V	GSM
1850.2 512	Y	-15.82	V	18.99	5.00	23.99	0.251	DC 3.7V	EDGE

- WCDMA1900 data

CH.	EUT Position (Axis)	Test Conditions(TPC bits all set to "1")							
		Reading Value (dBm)	Pol. (H/V)	LEVEL@ TX ANTENNA TERMINAL (dBm)	Antenna Gain (dBi)	EIRP (dBm)	EIRP (W)	Rated Voltage	Note.
1852.4 9262	Z	-17.97	V	16.80	5.00	21.80	0.151	DC 3.7V	-
1880.0 9400	Z	-17.46	V	17.32	4.94	22.26	0.168	DC 3.7V	-
1907.6 9538	Z	-19.25	V	15.42	4.88	20.30	0.107	DC 3.7V	-

- HSPA1900 data

CH.	EUT Position (Axis)	Test Conditions(TPC bits all set to "1")							
		Reading Value (dBm)	Pol. (H/V)	LEVEL@ TX ANTENNA TERMINAL (dBm)	Antenna Gain (dBi)	EIRP (dBm)	EIRP (W)	Rated Voltage	Note.
1852.4 9262	Z	- 19.01	V	15.76	5.00	20.76	0.119	DC 3.7V	-
1880.0 9400	Z	-18.15	V	16.63	4.94	21.57	0.144	DC 3.7V	-
1907.6 9538	Z	-20.18	V	14.49	4.88	19.37	0.087	DC 3.7V	-

NOTES:

This EUT was tested under all configurations and the highest power is reported in GSM mode and WCDMA mode with HSDPA inactive at 12.2 kbps RMC and TPC bits set to "1" and in GSM mode using a Power Control Level of "0" in PCS Band and "5" in the Cellular Band. This EUT was tested with the fully charged battery. Also, we have done x, y, z planes in EUT and horizontal and vertical polarization of detecting antenna. The worst case data is reported.

7.8 RADIATED SPURIOUS EMISSIONS

7.8.1 RADIATED SPURIOUS EMISSIONS (GSM850)

Channel (ERP)	Freq. (MHz)	EUT Position (Axis)	POL (H/V)	Level at Substitute Antenna Terminal (dBm)	Substitute Antenna Gain (dBd)	Correct Generator Level (dBm)	Result (dBc)	Limit (dBc)
128 (1.368 W)	1648.32	X	H	-51.23	3.13	-48.10	79.46	44.36
	2472.70	X	H	-49.93	3.53	-46.40	77.76	
	-	-	-	-	-	-	-	
190 (1.510 W)	1673.31	X	H	-52.69	3.11	-49.58	81.37	44.79
	2509.90	X	H	-52.69	3.11	-49.58	81.37	
	-	-	-	-	-	-	-	
251 (1.641 W)	1697.64	X	H	-53.22	3.09	-50.13	82.28	45.15
	2546.43	X	H	-52.18	3.72	-48.46	80.61	
	-	-	-	-	-	-	-	

- Limit Calculation= $43 + 10 \log_{10}(ERP [W])$ [dBc]

- No other spurious and harmonic emissions were reported greater than listed emissions above table.

NOTES:

This EUT was tested under all configurations and the highest power is reported in GSM mode and WCDMA mode with HSDPA inactive at 12.2 kbps RMC and TPC bits set to "1" and in GSM mode using a Power Control Level of "0" in PCS Band and "5" in the Cellular Band. This EUT was tested with the fully charged battery. Also, we have done x, y, z planes in EUT and horizontal and vertical polarization of detecting antenna.

The worst case data is reported.

7.8.2 RADIATED SPURIOUS EMISSIONS (GSM1900)

Channel (EIRP)	Freq. (MHz)	EUT Position (Axis)	POL (H/V)	Level at Substitute Antenna Terminal (dBm)	Substitute Antenna Gain (dBi)	Correct Generator Level (dBm)	Result (dBc)	Limit (dBc)
512 (0.834 W)	3700.14	X	V	-50.96	8.12	-42.84	72.05	42.21
	5550.52	X	V	-49.35	10.00	-39.35	68.56	
	-	-	-	-	-	-	-	
	-	-	-	-	-	-	-	
661 (0.805 W)	3760.10	X	V	-47.53	8.12	-39.41	68.47	42.06
	5639.90	X	V	-48.96	10.00	-38.96	68.02	
	-	-	-	-	-	-	-	
	-	-	-	-	-	-	-	
810 (0.671 W)	3819.72	X	V	-47.05	8.27	-38.78	67.05	41.27
	5729.60	X	V	-52.46	10.00	-42.46	70.73	
	-	-	-	-	-	-	-	
	-	-	-	-	-	-	-	

- Limit Calculation = $43 + 10 \log_{10}(\text{EIRP [W]})$ [dBc]

- No other spurious and harmonic emissions were reported greater than listed emissions above table.

NOTES:

This EUT was tested under all configurations and the highest power is reported in GSM mode and WCDMA mode with HSDPA inactive at 12.2 kbps RMC and TPC bits set to “1” and in GSM mode using a Power Control Level of “0” in PCS Band and “5” in the Cellular Band. This EUT was tested with the fully charged battery. Also, we have done x, y, z planes in EUT and horizontal and vertical polarization of detecting antenna.

The worst case data is reported.

7.8.3 RADIATED SPURIOUS EMISSIONS (WCDMA1900)

Channel (EIRP)	Freq. (MHz)	EUT Position (Axis)	POL (H/V)	LEVEL@ ANTENNA TERMINAL (dBm)	SUBSTITUTE ANTENNA GAIN (dBi)	CORRECT GENERATOR LEVEL (dBm)	Result (dBc)	Limit (dBc)
9262 (0.151 W)	3707.22	Z	V	-38.99	8.12	-30.87	52.67	34.80
	5559.12	Z	V	-47.31	10.00	-37.31	59.11	
	-	-	-	-	-	-	-	
9400 (0.168 W)	3758.51	Z	V	-42.97	8.12	-34.85	57.11	35.26
	5642.20	Z	V	-51.01	10.00	-41.01	63.27	
	-	-	-	-	-	-	-	
9538 (0.107 W)	3817.10	Z	V	-42.34	8.26	-34.08	54.38	33.30
	5726.53	Z	V	-51.70	10.00	-41.70	62.00	
	-	-	-	-	-	-	-	

- Limit Calculation = $43 + 10 \log_{10} (\text{EIRP [W]})$ [dBc]

- No other spurious and harmonic emissions were reported greater than listed emissions above table.

NOTES:

This EUT was tested under all configurations and the highest power is reported in GSM mode and WCDMA mode with HSDPA inactive at 12.2 kbps RMC and TPC bits set to "1" and in GSM mode using a Power Control Level of "0" in PCS Band and "5" in the Cellular Band. This EUT was tested with the fully charged battery. Also, we have done x, y, z planes in EUT and horizontal and vertical polarization of detecting antenna.

The worst case data is reported.

7.8.4 RADIATED SPURIOUS EMISSIONS (HSUPA1900)

Channel (EIRP)	Freq. (MHz)	EUT Position (Axis)	POL (H/V)	LEVEL@ ANTENNA TERMINAL (dBm)	SUBSTITUTE ANTENNA GAIN (dBi)	CORRECT GENERATOR LEVEL (dBm)	Result (dBc)	Limit (dBc)
9262 (0.119 W)	3703.05	Z	V	-40.79	8.12	-32.67	53.43	33.76
	5555.50	Z	V	-47.57	10.00	-37.57	58.33	
9400 (0.144 W)	3762.23	Z	V	-44.62	8.13	-36.49	58.06	34.57
	5644.18	Z	V	-52.19	10.00	-42.19	63.76	
9538 (0.087 W)	3813.35	Z	V	-42.24	8.25	-33.99	53.36	32.37
	5720.64	Z	V	-52.04	10.00	-42.04	61.41	
	-	-	-	-	-	-	-	

- Limit Calculation = $43 + 10 \log_{10} (\text{EIRP [W]})$ [dBc]

- No other spurious and harmonic emissions were reported greater than listed emissions above table.

NOTES:

This EUT was tested under all configurations and the highest power is reported in GSM mode and WCDMA mode with HSDPA inactive at 12.2 kbps RMC and TPC bits set to “1” and in GSM mode using a Power Control Level of “0” in PCS Band and “5” in the Cellular Band. This EUT was tested with the fully charged battery. Also, we have done x, y, z planes in EUT and horizontal and vertical polarization of detecting antenna.

The worst case data is reported.

7.9 FREQUENCY STABILITY / VARIATION OF AMBIENT TEMPERATURE

7.9.1 FREQUENCY STABILITY (GSM850)

OPERATING FREQUENCY : 836,599,984 Hz
 CHANNEL : 190(Mid)
 REFERENCE VOLTAGE : 3.700 V DC
 DEVIATION LIMIT : ± 0.00025 % or 2.5 ppm

VOLTAGE (%)	POWER (V DC)	TEMP (°C)	FREQ (Hz)	Deviation	
				(ppm)	(%)
100 %	3.700	+ 25(Ref)	836,599,984	0.000	0.00000000
100 %		- 30	836,599,983	- 0.001	- 0.00000012
100 %		- 20	836,599,988	0.005	0.00000048
100 %		- 10	836,599,986	0.002	0.00000024
100 %		0	836,599,988	0.005	0.00000048
100 %		+ 10	836,599,978	- 0.007	- 0.00000072
100 %		+ 20	836,599,984	0.000	0.00000000
100 %		+ 30	836,599,981	- 0.004	- 0.00000036
100 %		+ 40	836,599,986	0.002	0.00000024
100 %		+ 50	836,599,985	0.001	0.00000012
85 %		3.145	+ 25	836,599,987	0.004
115 %	4.255	+ 25	836,599,989	0.006	0.00000060
BATT.ENDPOINT	2.650	+ 25	836,599,986	0.002	0.00000024

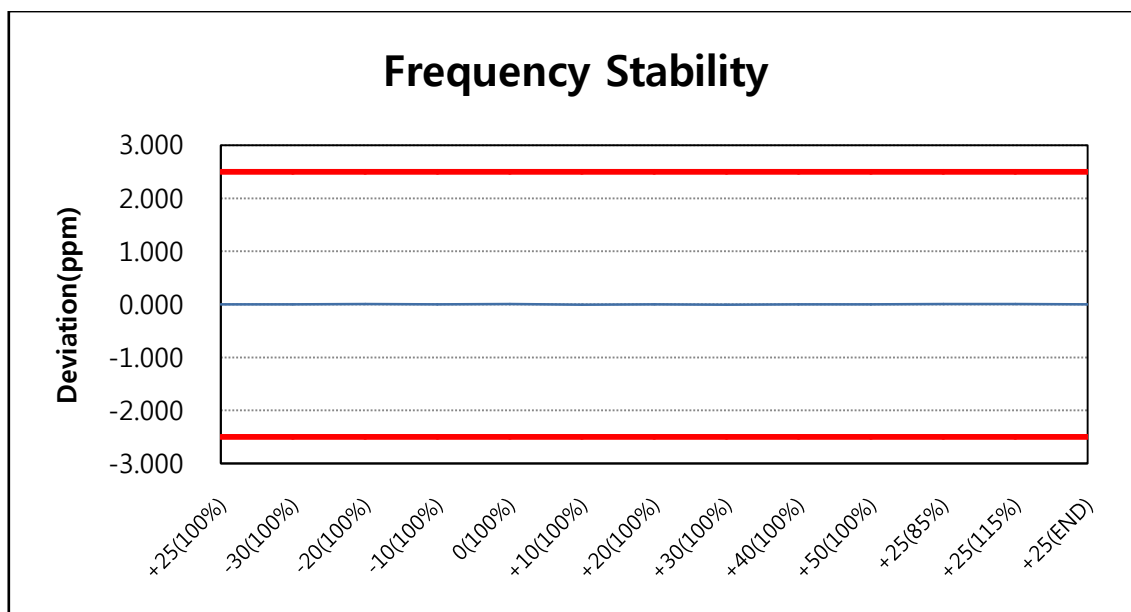

7.9.2 FREQUENCY STABILITY (GSM1900)

OPERATING FREQUENCY : 1,879,999,988 Hz
 CHANNEL : 661(Mid)
 REFERENCE VOLTAGE : 3.700 V DC
 DEVIATION LIMIT : ± 0.00025 % or 2.5 ppm

VOLTAGE (%)	POWER (V DC)	TEMP (°C)	FREQ (Hz)	Deviation	
				(ppm)	(%)
100 %	3.700	+ 25(Ref)	1,879,999,988	0.000	0.00000000
100 %		- 30	1,879,999,980	- 0.004	- 0.00000043
100 %		- 20	1,879,999,978	- 0.005	- 0.00000053
100 %		- 10	1,879,999,986	- 0.001	- 0.00000011
100 %		0	1,879,999,983	- 0.003	- 0.00000027
100 %		+ 10	1,879,999,980	- 0.004	- 0.00000043
100 %		+ 20	1,879,999,977	- 0.006	- 0.00000059
100 %		+ 30	1,879,999,978	- 0.005	- 0.00000053
100 %		+ 40	1,879,999,989	0.001	0.00000005
100 %		+ 50	1,879,999,984	- 0.002	- 0.00000021
85 %	3.145	+ 25	1,879,999,987	- 0.001	- 0.00000005
115 %	4.255	+ 25	1,879,999,978	- 0.005	- 0.00000053
BATT.ENDPOINT	2.650	+ 25	1,879,999,981	- 0.004	- 0.00000037

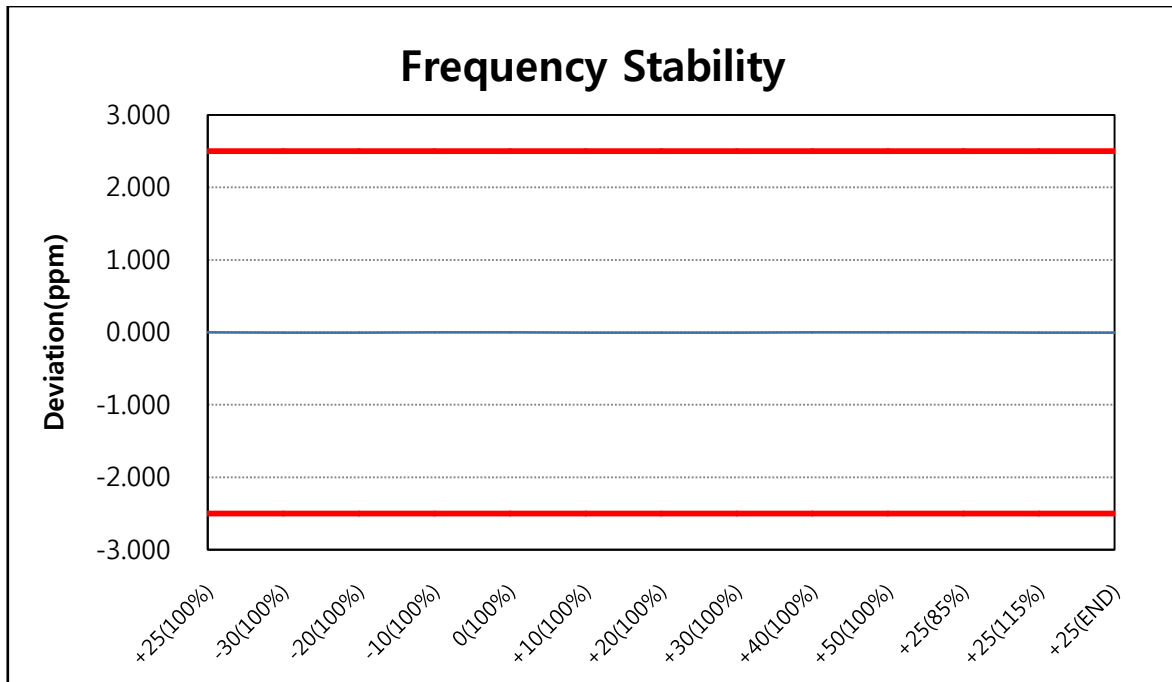

7.9.3 FREQUENCY STABILITY (WCDMA1900)

OPERATING FREQUENCY : 1,879,999,988 Hz
 CHANNEL : 9400(Mid)
 REFERENCE VOLTAGE : 3.700 V DC
 DEVIATION LIMIT : ± 0.00025 % or 2.5 ppm

VOLTAGE (%)	POWER (V DC)	TEMP (°C)	FREQ (Hz)	Deviation	
				(ppm)	(%)
100%	3.700	+ 25(Ref)	1,879,999,988	0.000	0.00000000
100%		- 30	1,879,999,992	0.002	0.00000021
100%		- 20	1,879,999,989	0.001	0.00000005
100%		- 10	1,879,999,988	0.000	0.00000000
100%		0	1,879,999,992	0.002	0.00000021
100%		+ 10	1,879,999,991	0.002	0.00000016
100%		+ 20	1,879,999,993	0.003	0.00000027
100%		+ 30	1,879,999,986	- 0.001	- 0.00000011
100%		+ 40	1,879,999,988	0.000	0.00000000
100%		+ 50	1,879,999,989	0.001	0.00000005
85%	3.145	+ 25	1,879,999,990	0.001	0.00000011
115%	4.255	+ 25	1,879,999,992	0.002	0.00000021
BATT.ENDPOINT	2.650	+ 25	1,879,999,990	0.001	0.00000011

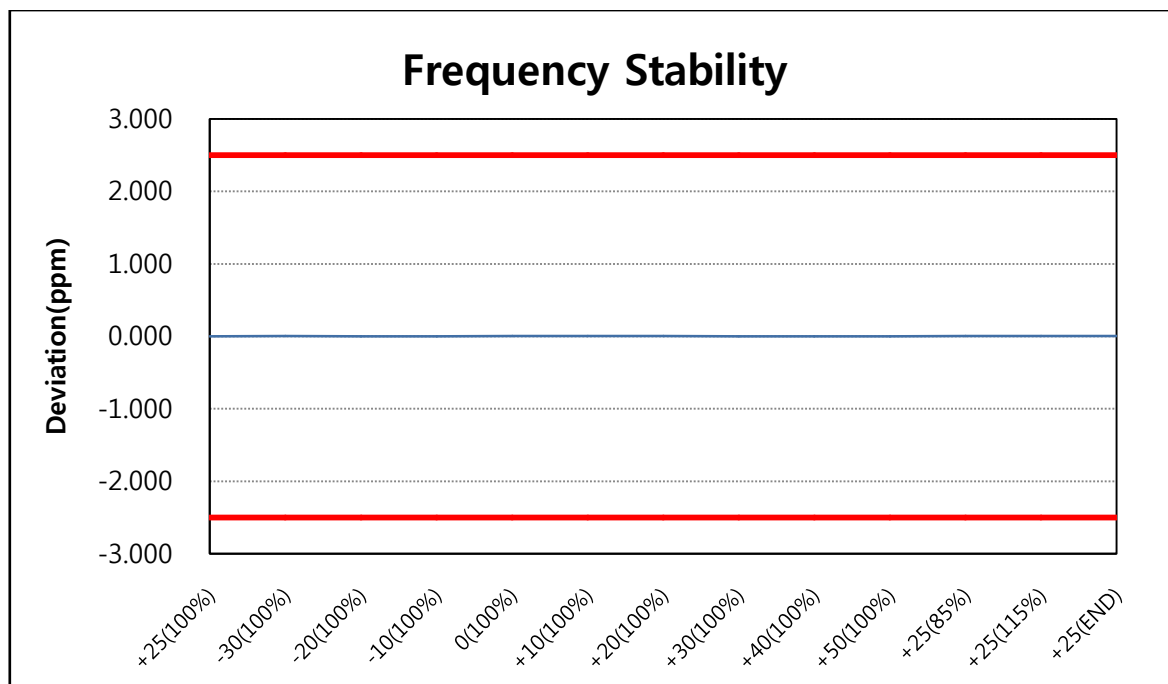

7.9.4 FREQUENCY STABILITY (HSUPA1900)

OPERATING FREQUENCY : 1,879,999,989 Hz
 CHANNEL : 9400(Mid)
 REFERENCE VOLTAGE : 3.700 V DC
 DEVIATION LIMIT : ± 0.00025 % or 2.5 ppm

VOLTAGE (%)	POWER (V DC)	TEMP (°C)	FREQ (Hz)	Deviation	
				(ppm)	(%)
100%	3.700	+ 25(Ref)	1,879,999,989	0.000	0.00000000
100%		- 30	1,879,999,993	0.002	0.00000021
100%		- 20	1,879,999,986	- 0.002	- 0.00000016
100%		- 10	1,879,999,989	0.000	0.00000000
100%		0	1,879,999,992	0.002	0.00000016
100%		+ 10	1,879,999,988	- 0.001	- 0.00000005
100%		+ 20	1,879,999,986	- 0.002	- 0.00000016
100%		+ 30	1,879,999,992	0.002	0.00000016
100%		+ 40	1,879,999,990	0.001	0.00000005
100%		+ 50	1,879,999,987	- 0.001	- 0.00000011
85%	3.145	+ 25	1,879,999,991	0.001	0.00000011
115%	4.255	+ 25	1,879,999,988	- 0.001	- 0.00000005
BATT.ENDPOINT	2.650	+ 25	1,879,999,986	- 0.002	- 0.00000016

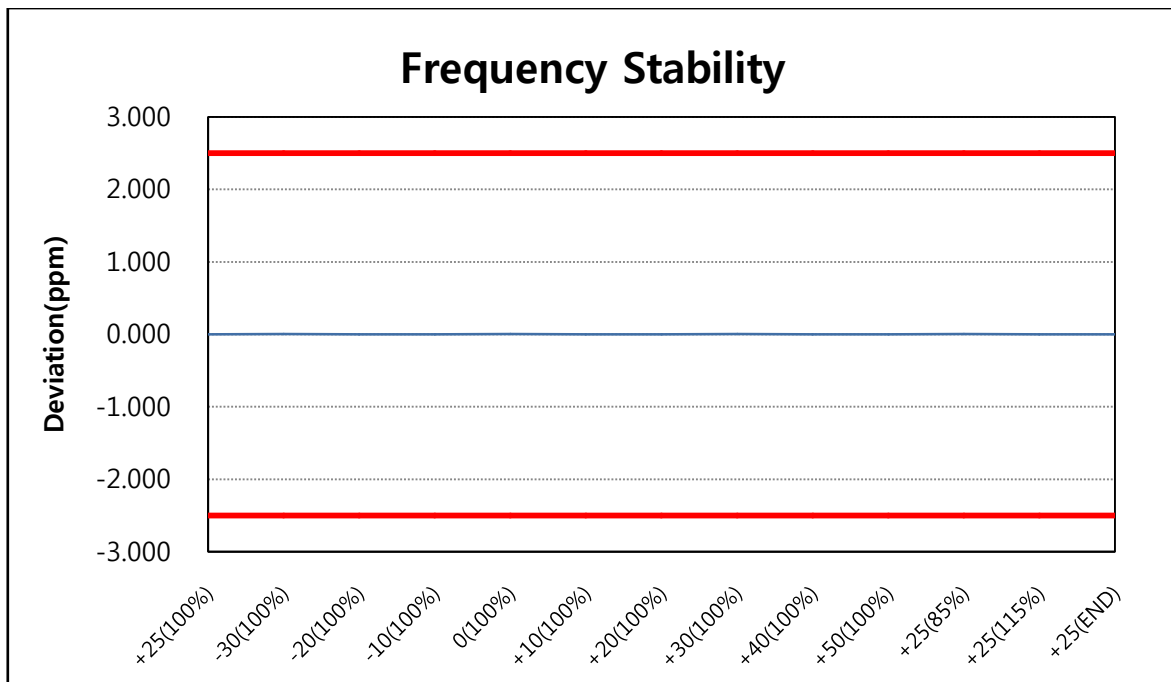

8. TEST PLOTS

8.1 Peak to Average Ratio - P_{PK} (dBm)

GSM1900 & Channel: 661

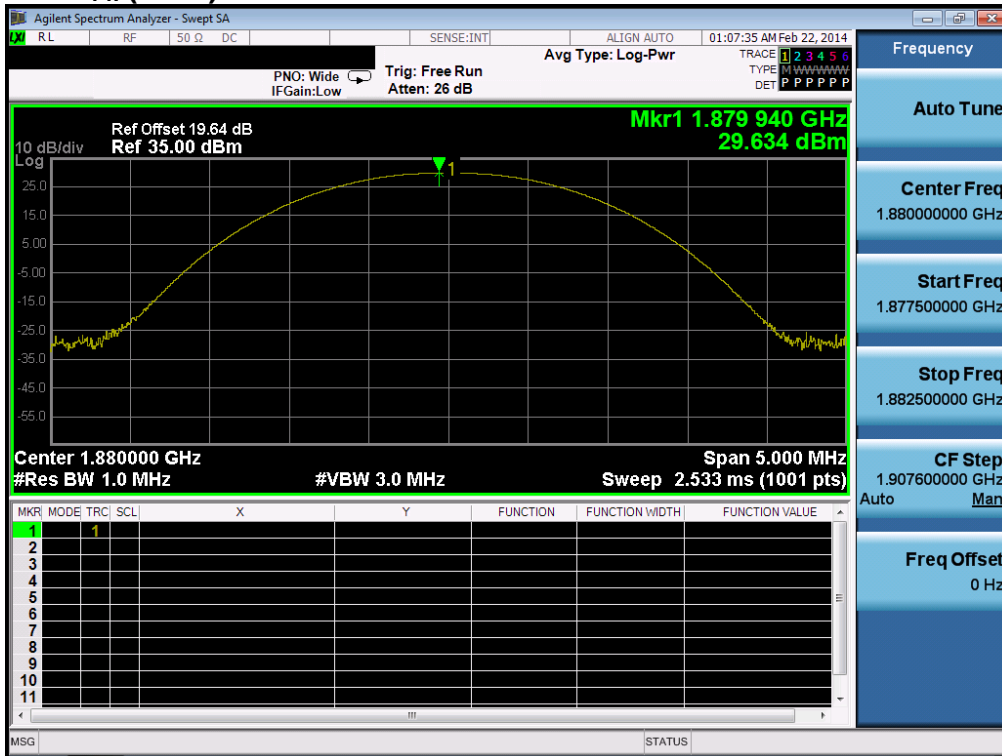

- P_{Avg} (dBm)

GSM1900 & Channel: 661

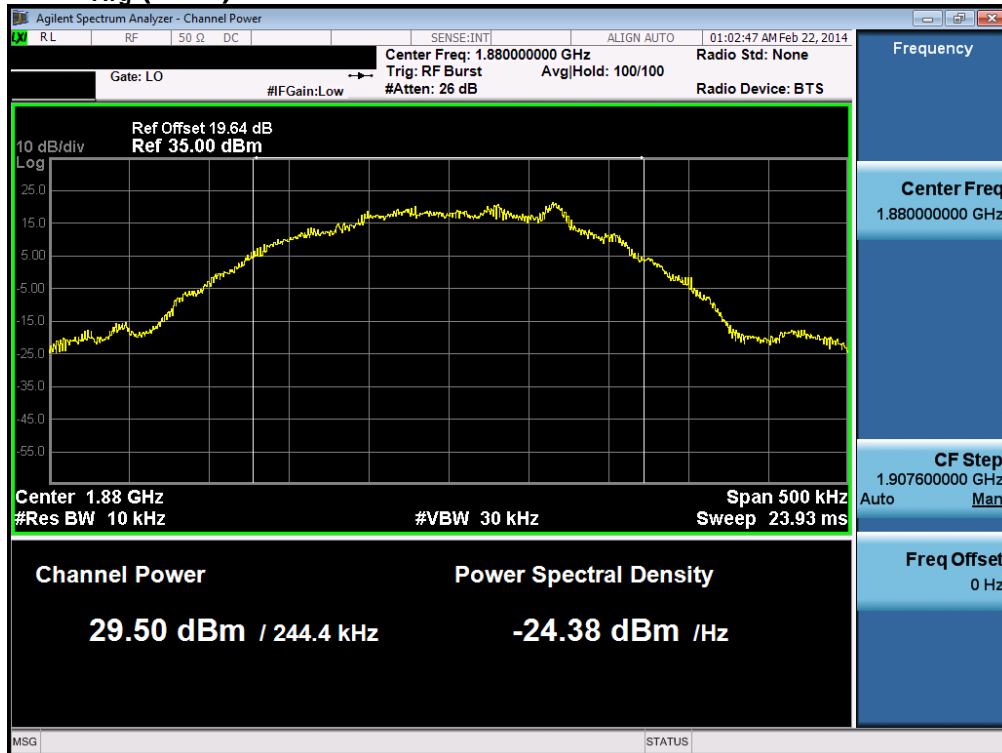

$$\text{PAPR (dB)} = P_{\text{PK}} \text{ (dBm)} - P_{\text{Avg}} \text{ (dBm)} = 29.634\text{dBm} - 29.50 \text{ dBm} = 0.134 \text{ dB}$$

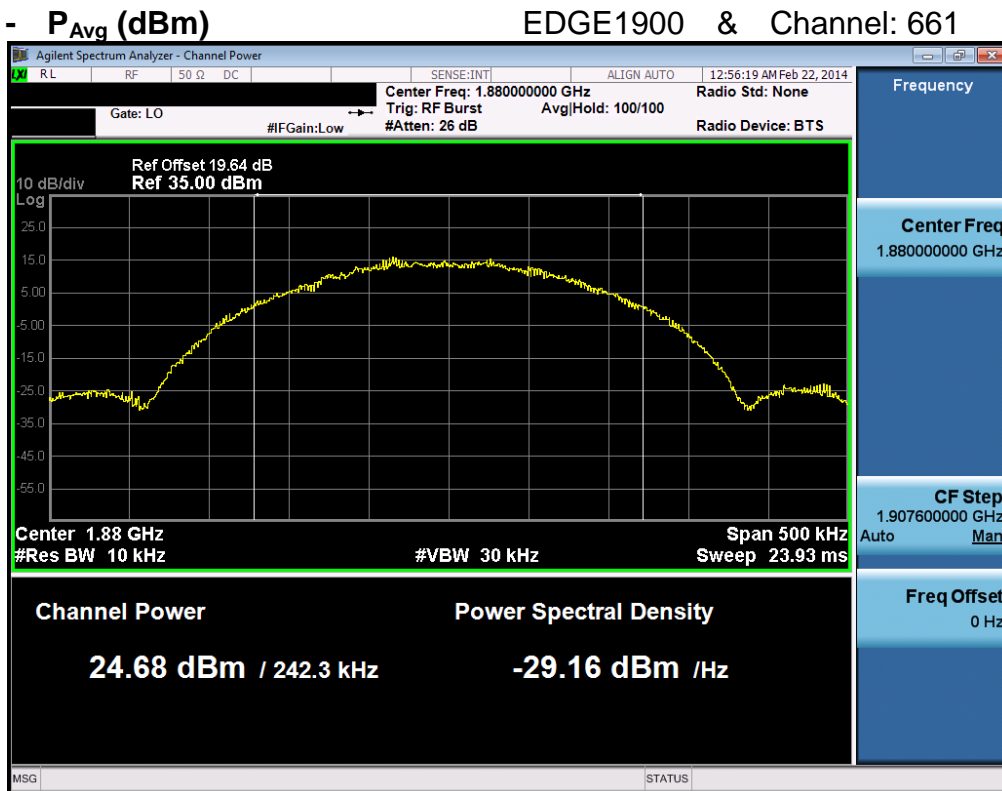
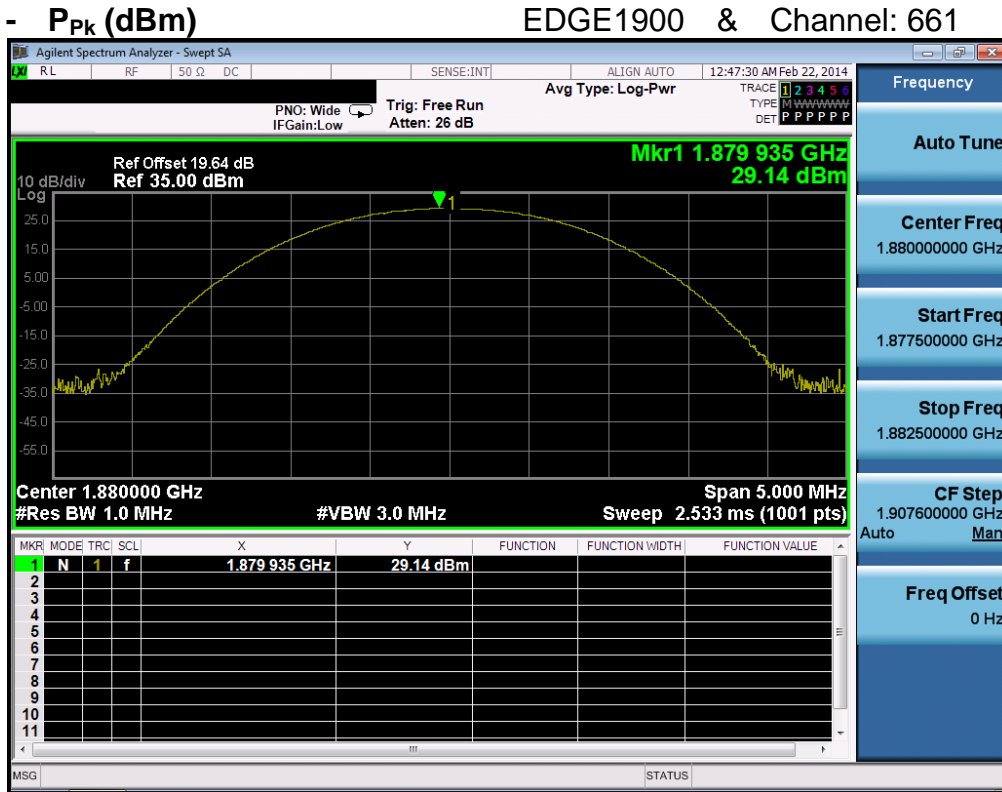

PAPR (dB) = P_{Pk} (dBm) - P_{Avg} (dBm) = 29.14 dBm - 24.68 dBm = 4.46 dB

WCDMA1900 & Channel: 9400

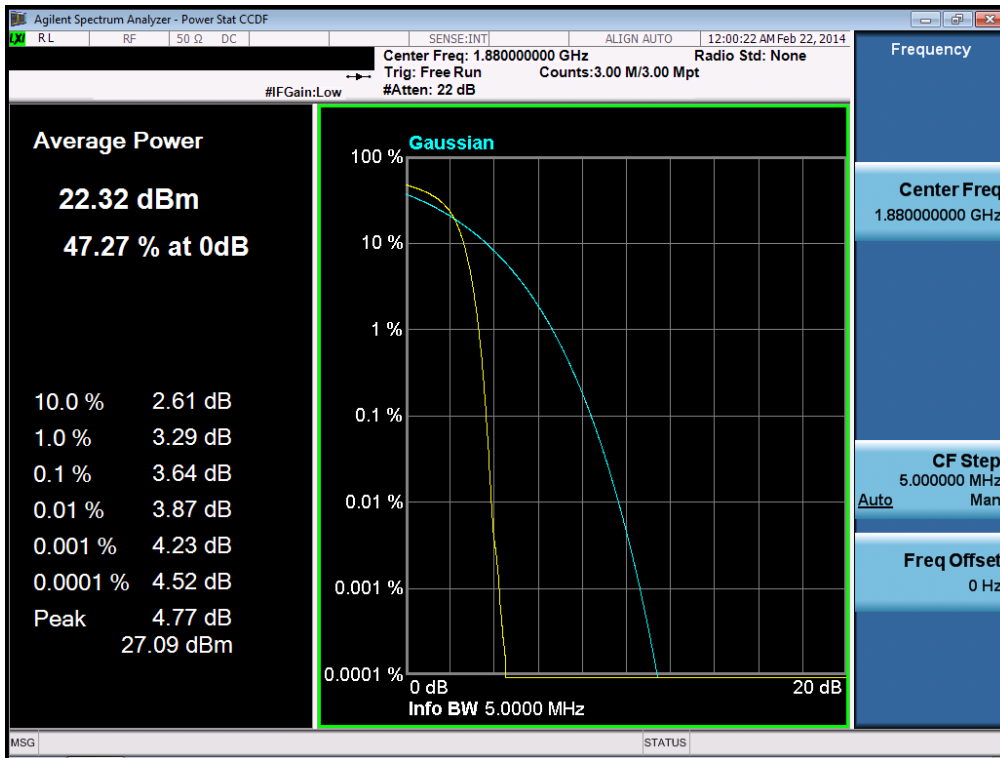

HSUPA1900 & Channel: 9400

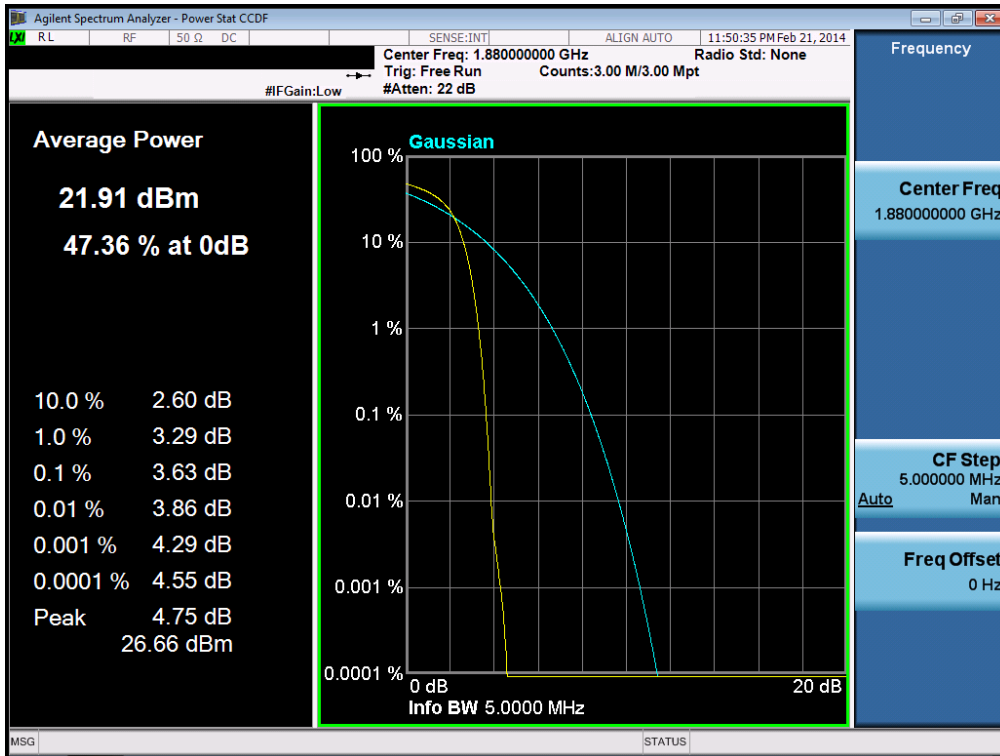

8.2 Occupied Bandwidth 99 % Bandwidth

GSM850 & Channel: 128

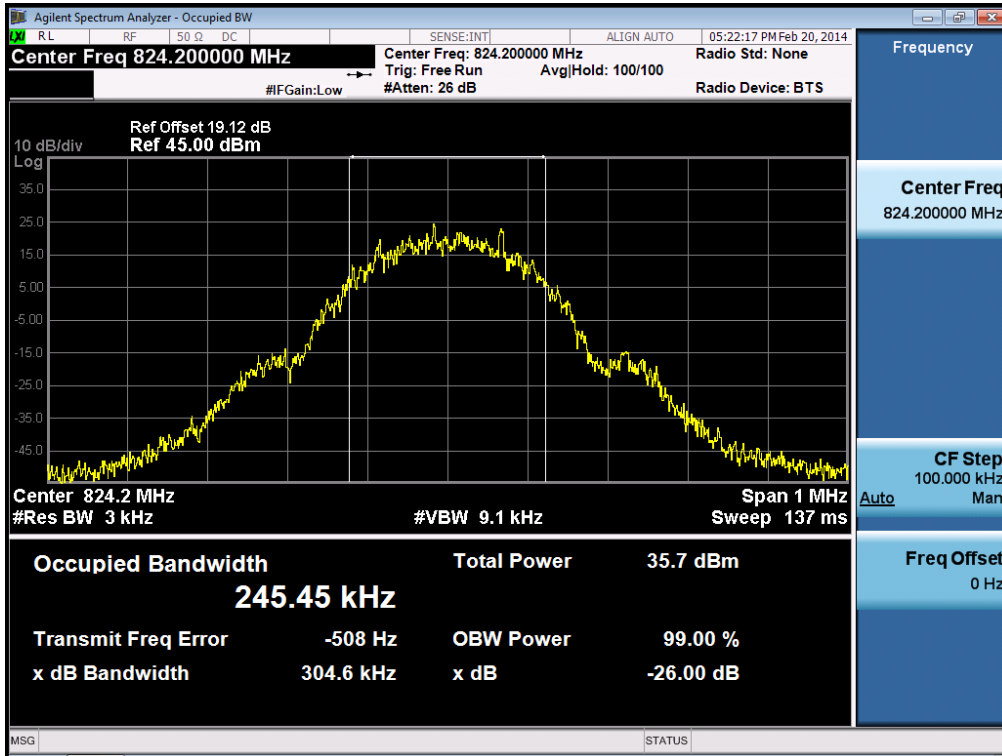

GSM850 & Channel: 190

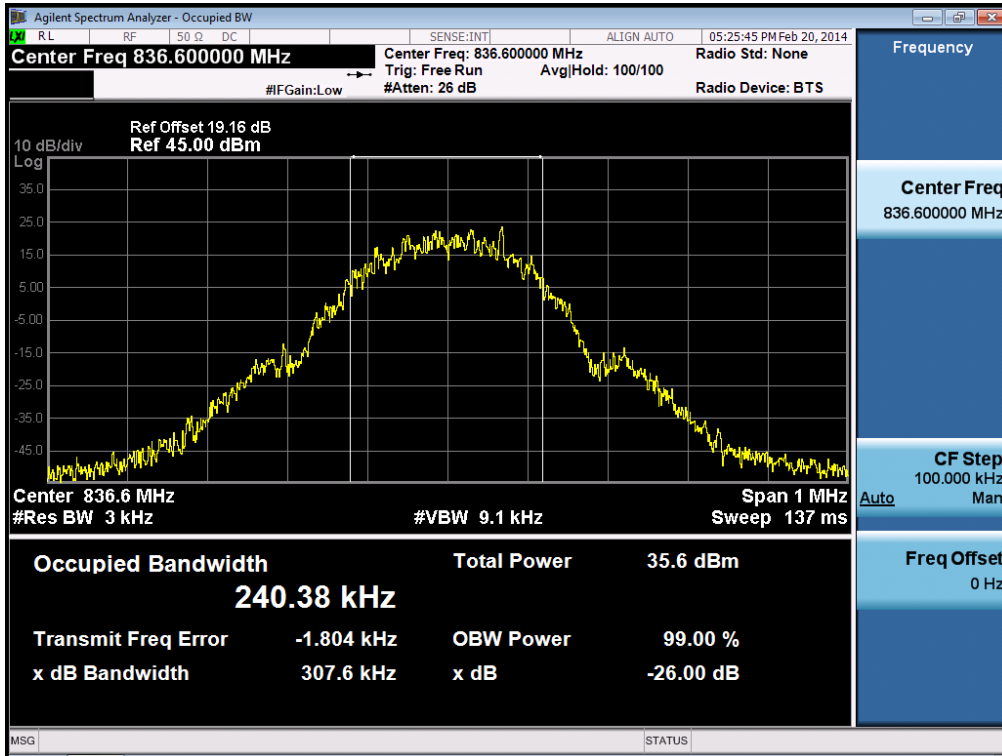

GSM850 & Channel: 251

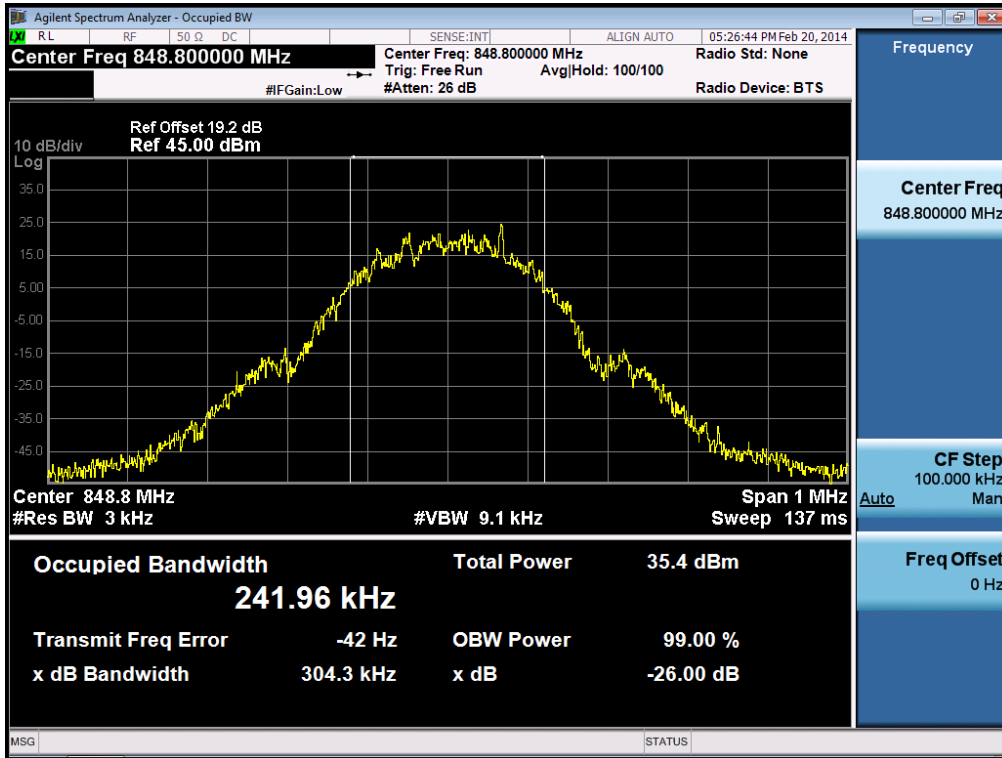

EDGE 850 & Channel: 128

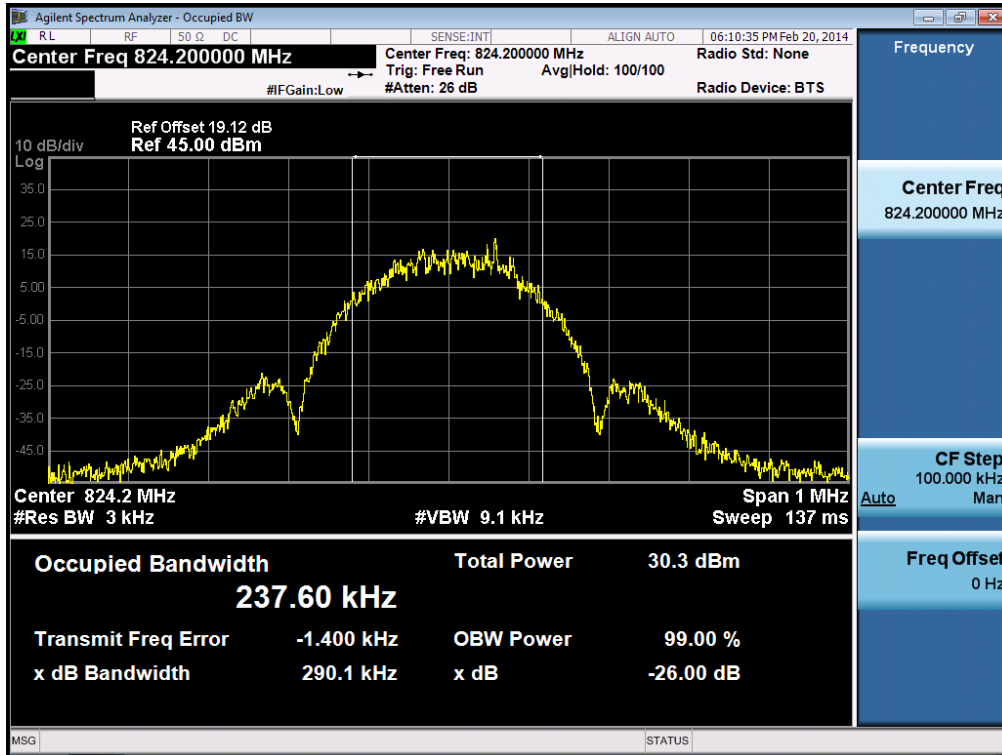

EDGE 850 & Channel: 190

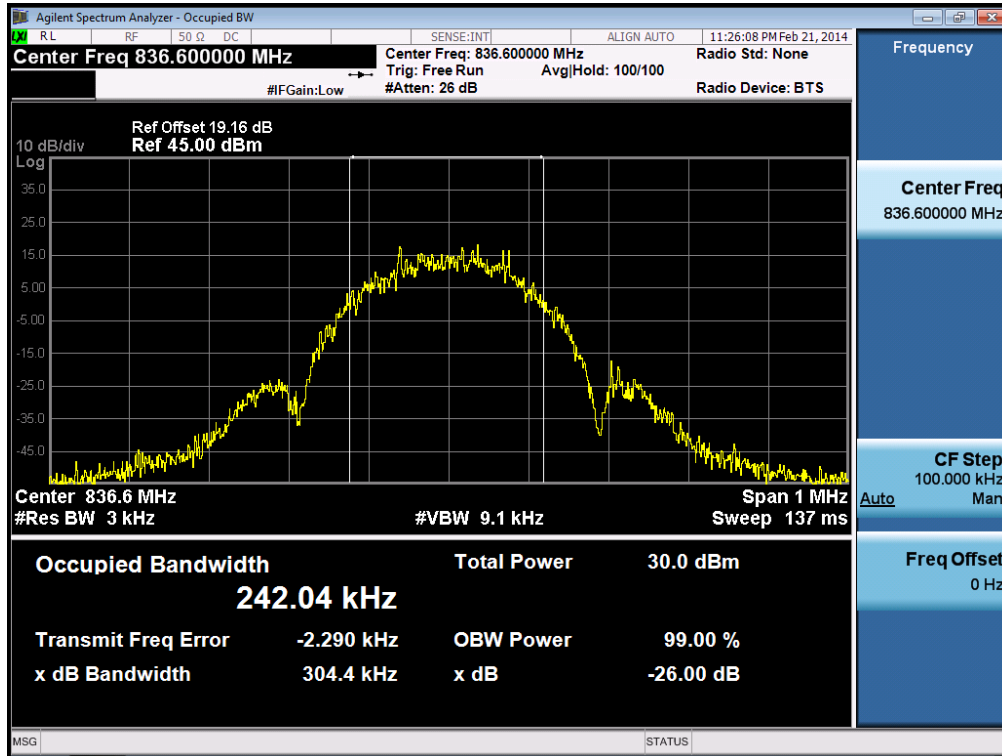

EDGE 850 & Channel: 251

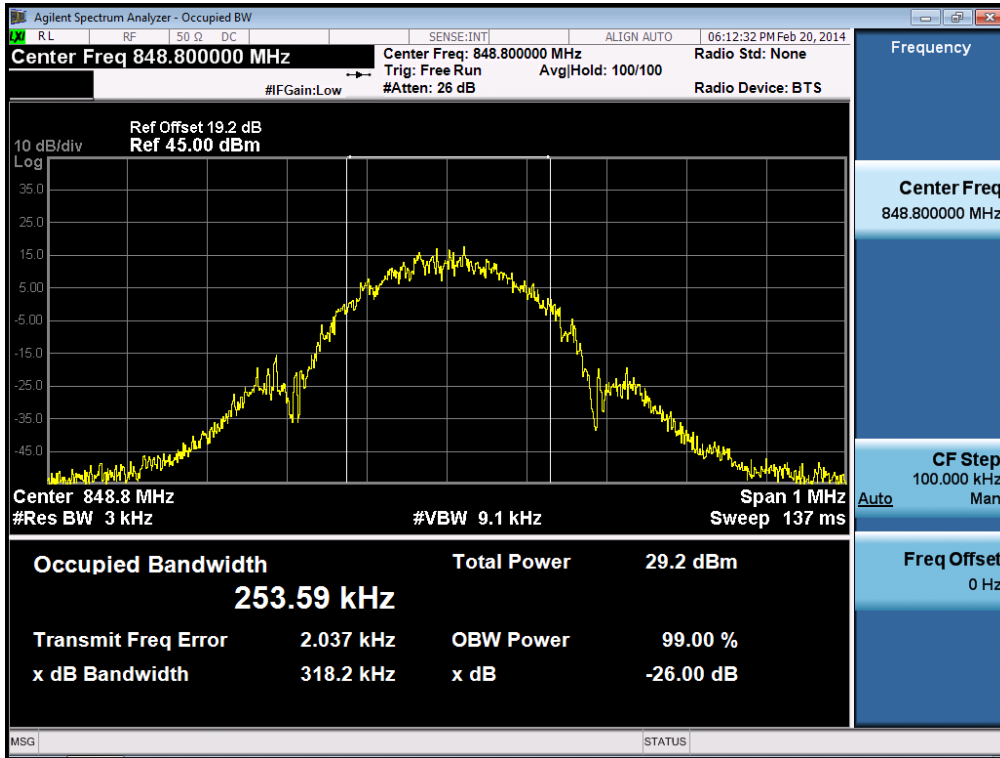

GSM 1900 & Channel: 512

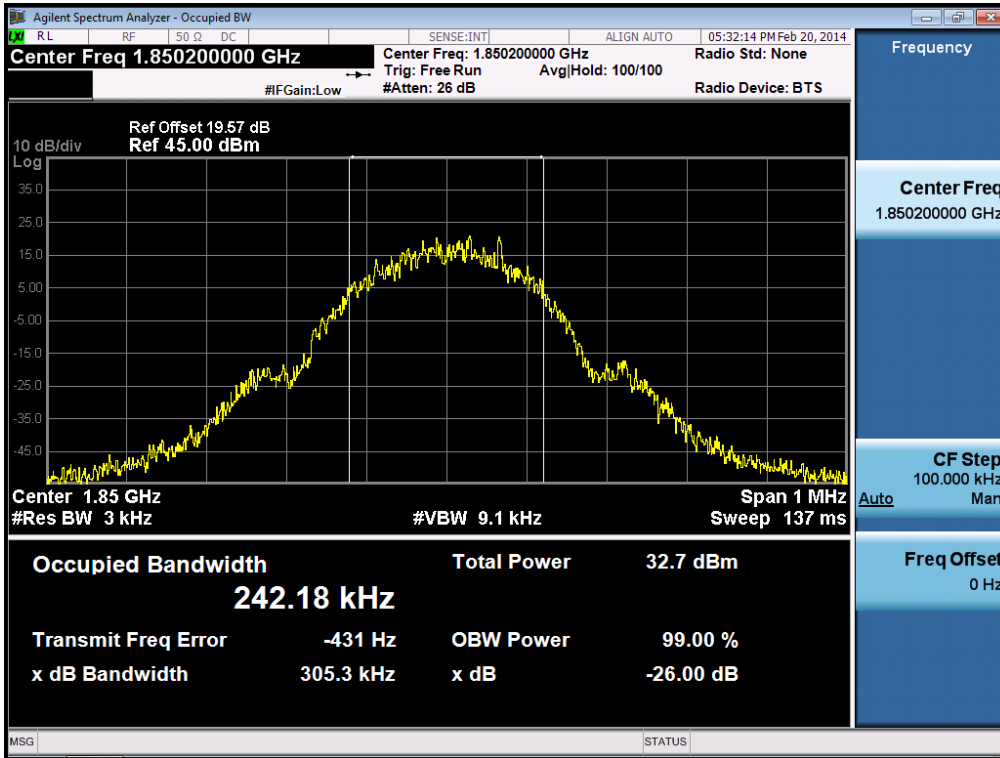

GSM 1900 & Channel: 661

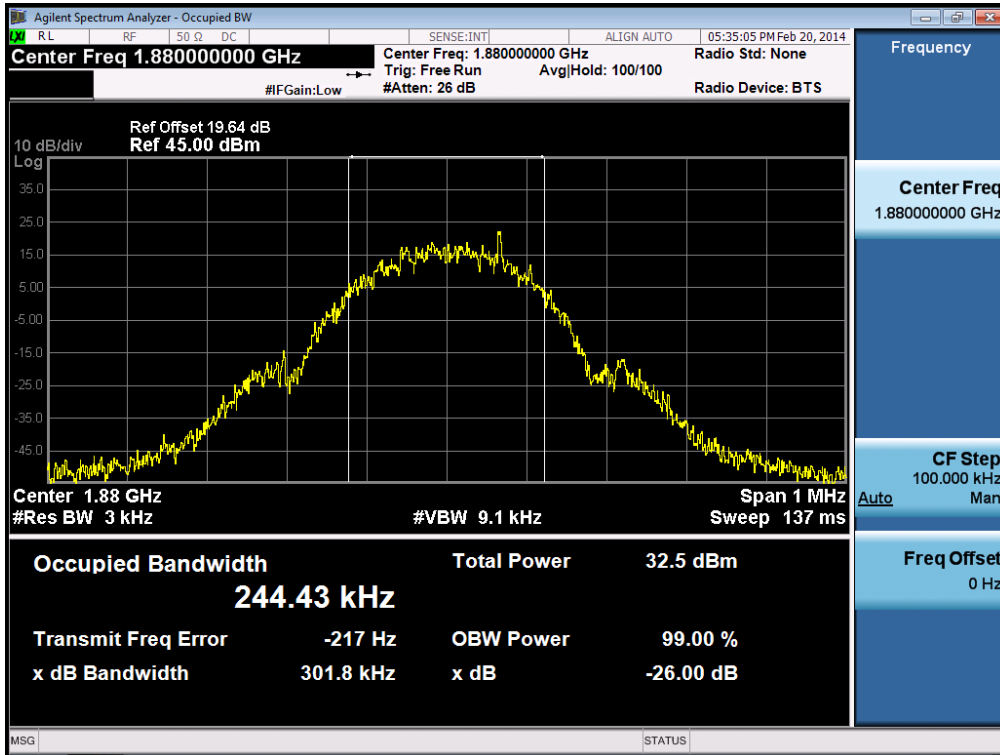

GSM 1900 & Channel: 810

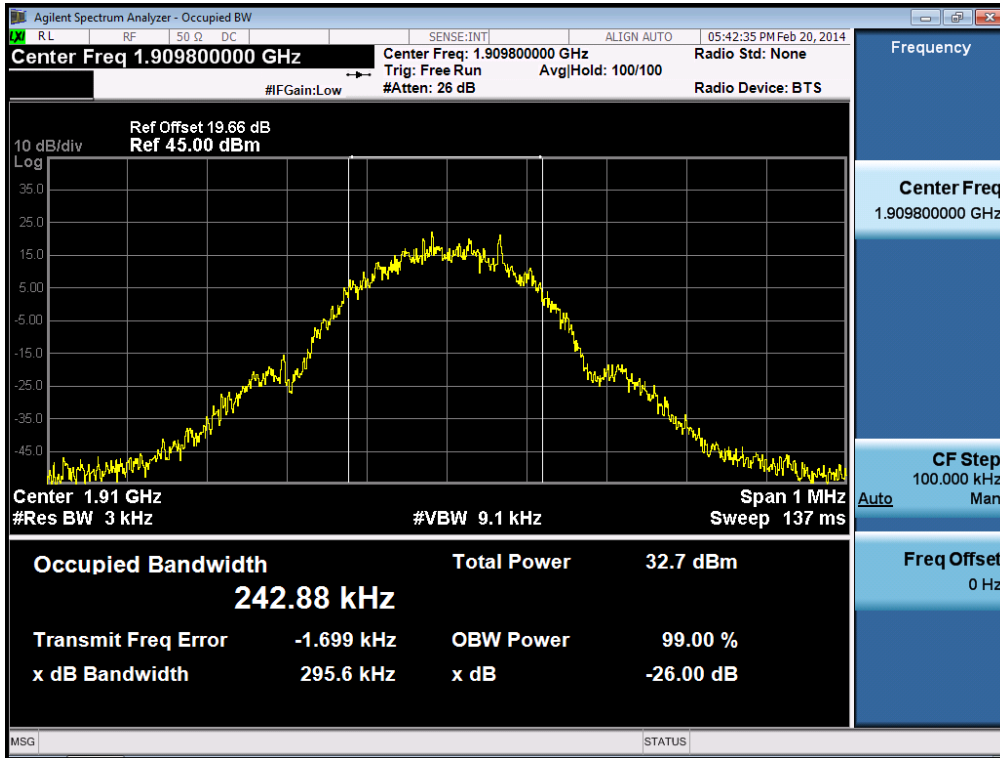

EDGE 1900 & Channel: 512

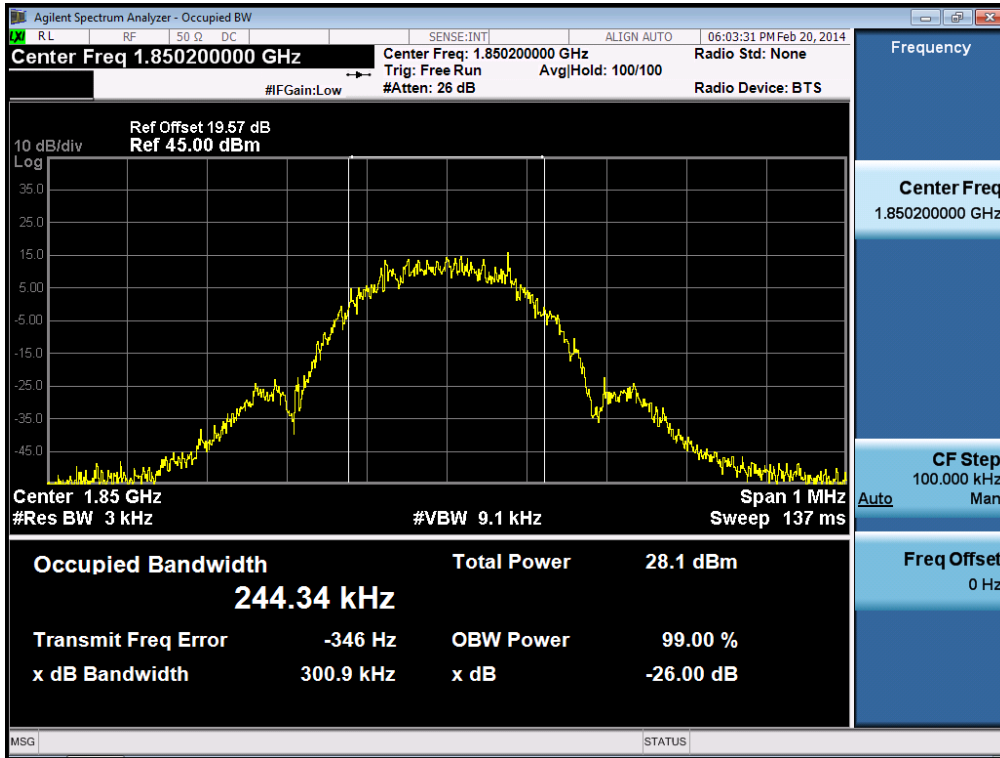

EDGE 1900 & Channel: 661

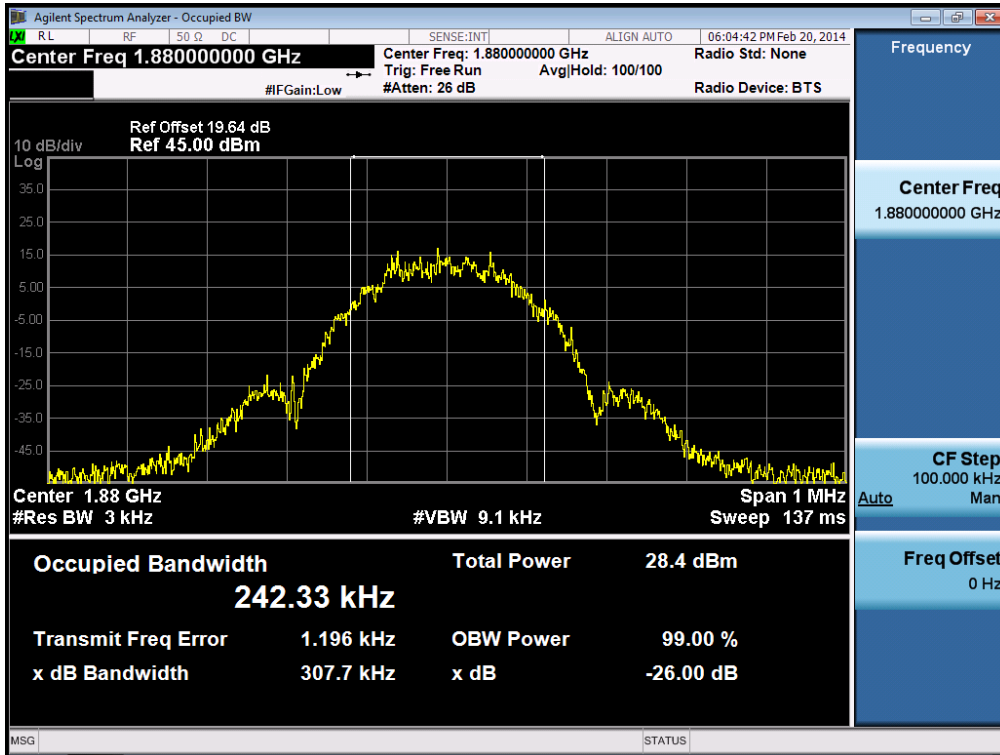

EDGE 1900 & Channel: 810

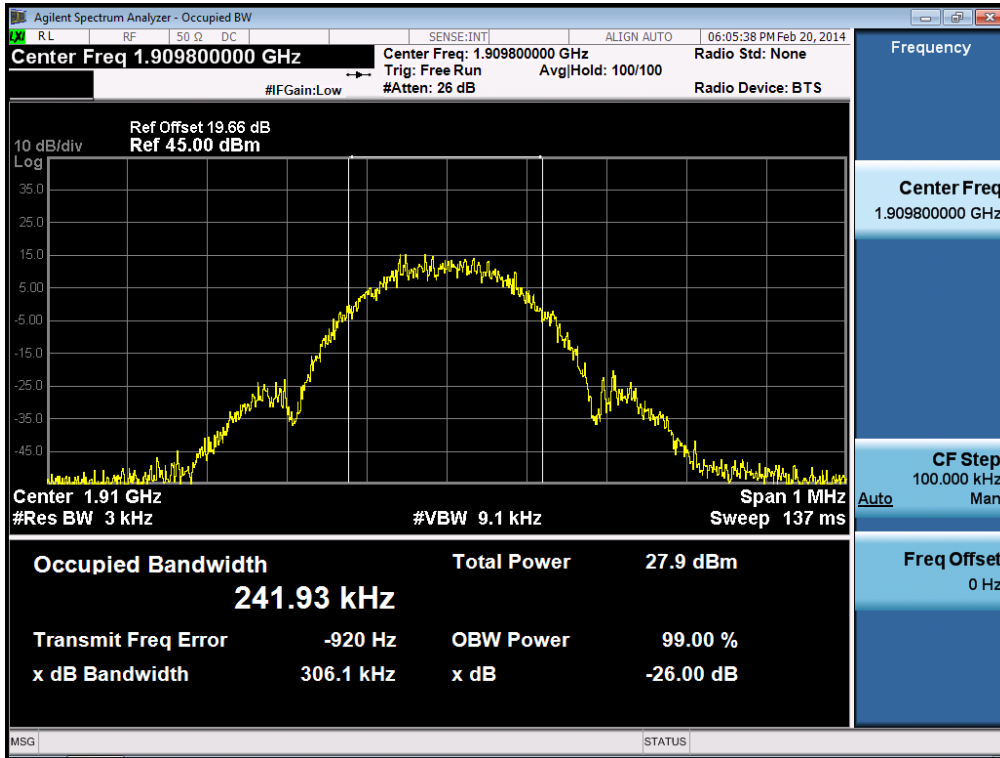

WCDMA1900 & Channel: 9262

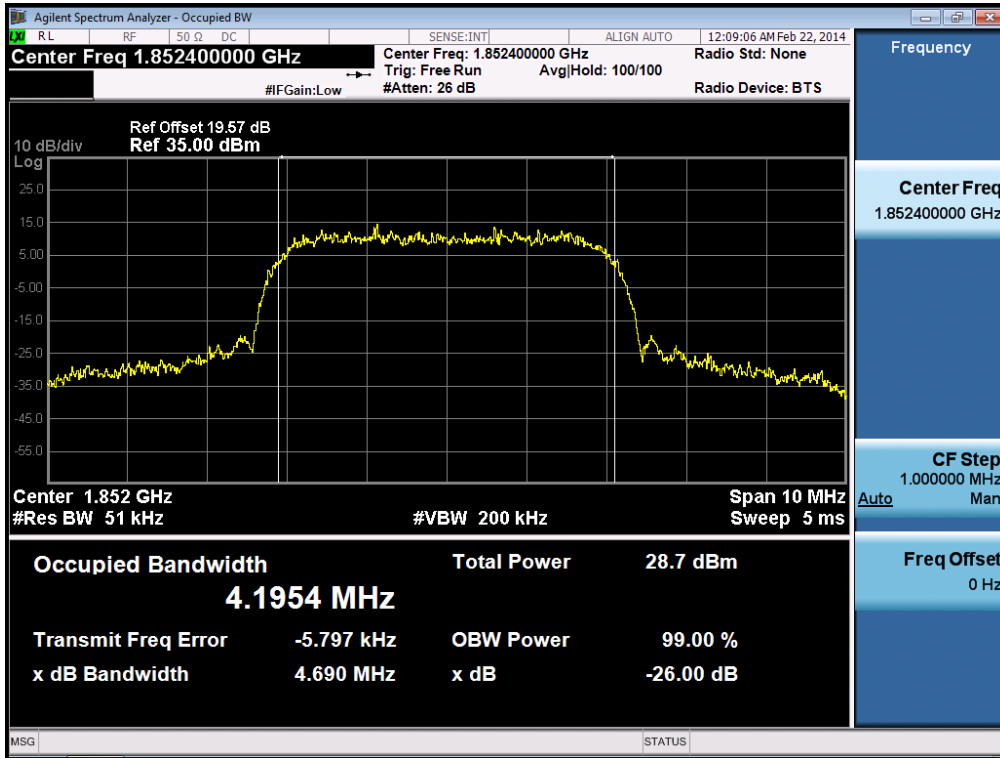

WCDMA1900 & Channel: 9400

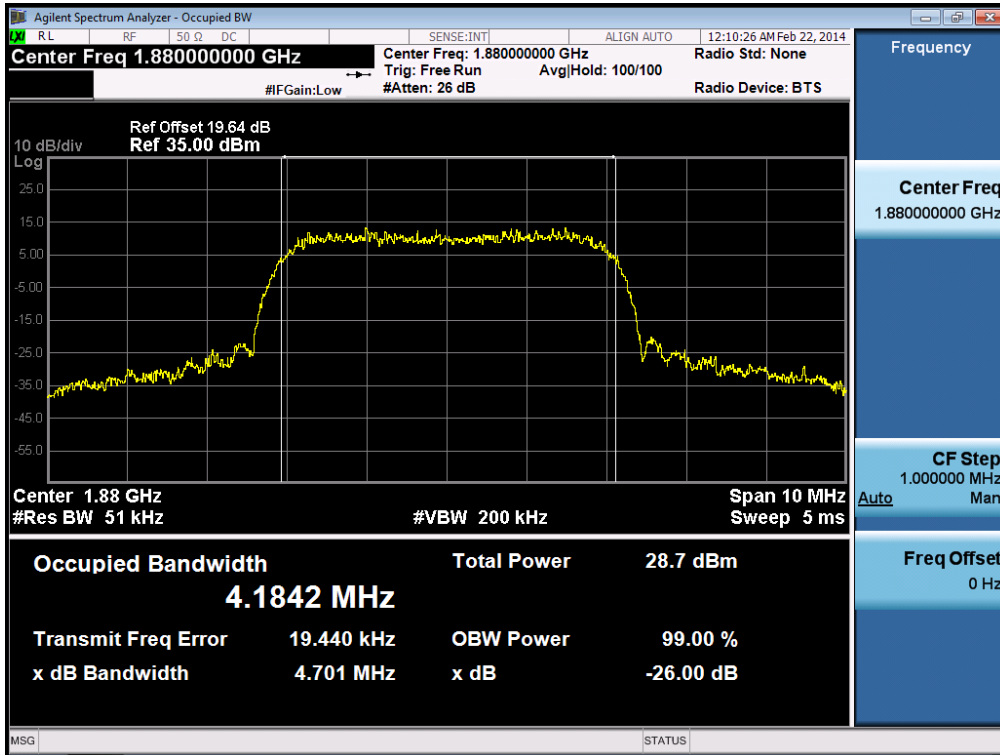

WCDMA1900 & Channel: 9538

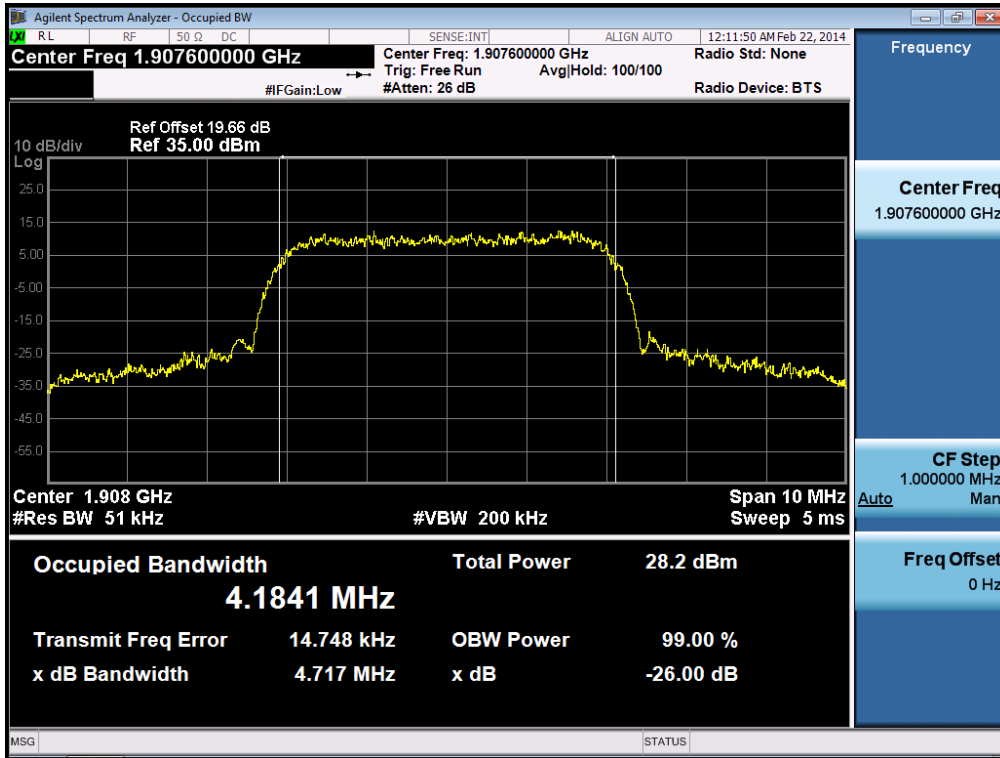

HSUPA1900 & Channel: 9262

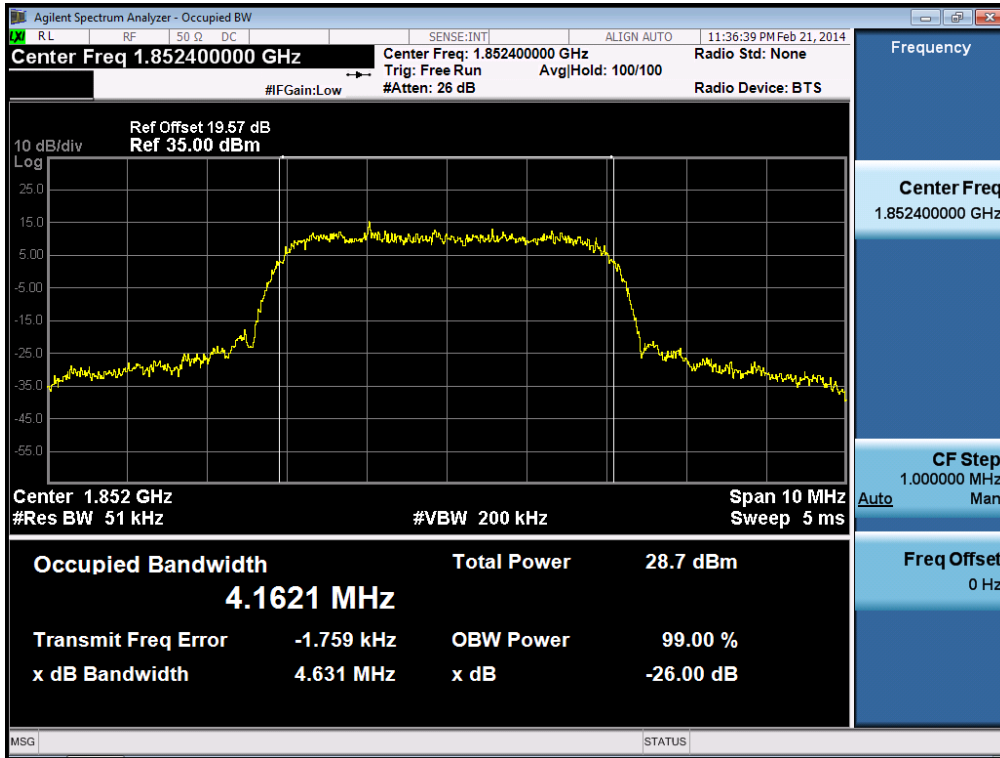

HSUPA1900 & Channel: 9400

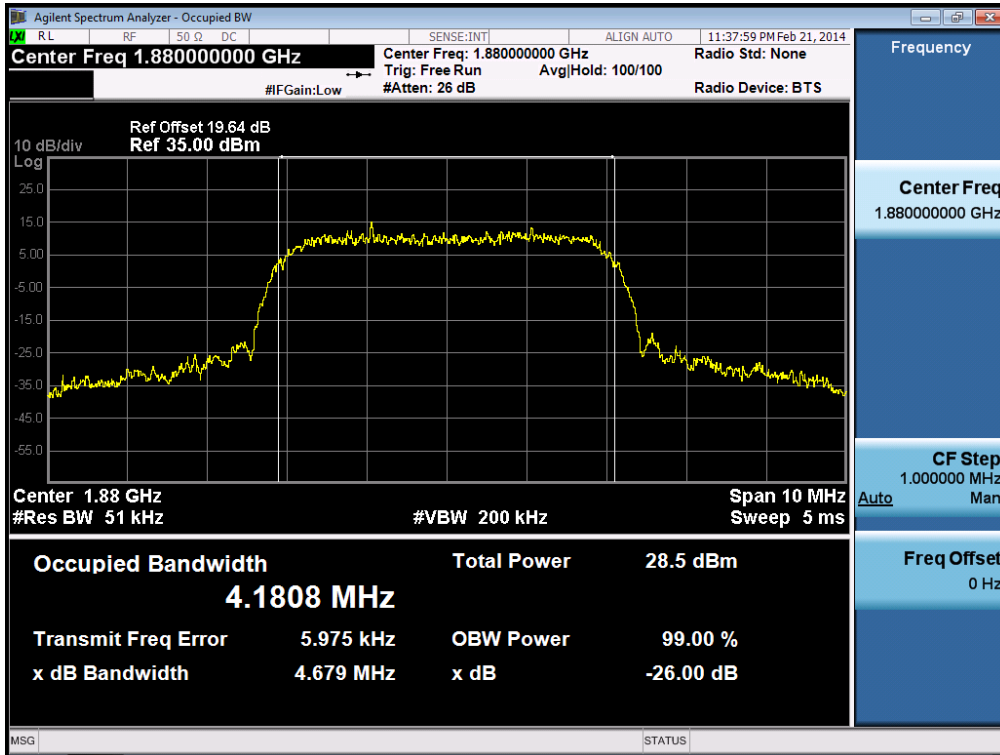

HSUPA1900 & Channel: 9538

