

5. 20dBc BW

5.1. Test Setup

Refer to the APPENDIX I.

5.2. Limit

Limit: Not Applicable

5.3. Test Procedure

1. The 20dBc bandwidth were measured with a spectrum analyzer connected to RF antenna connector (conducted measurement) while EUT was operating in transmit mode. The analyzer center frequency was set to the EUT carrier frequency, using the analyzer.
2. The bandwidth of the fundamental frequency was measured with the spectrum analyzer using $RBW \geq 1\%$ of the 20 dB bandwidth, $VBW \geq RBW$, Span = 3MHz.

5.4. Test Results

Ambient temperature : 26°C
 Relative humidity : 45%

Modulation	Tested Channel	20dBc BW (MHz)
<u>GFSK</u>	Lowest	0.930
	Middle	0.890
	Highest	0.890
<u>$\pi/4$DQPSK</u>	Lowest	1.300
	Middle	1.320
	Highest	1.320
<u>8DPSK</u>	Lowest	1.300
	Middle	1.270
	Highest	1.280

Note 1: See next pages for actual measured spectrum plots.

20dBc Bandwidth

Lowest Channel & Modulation: GFSK

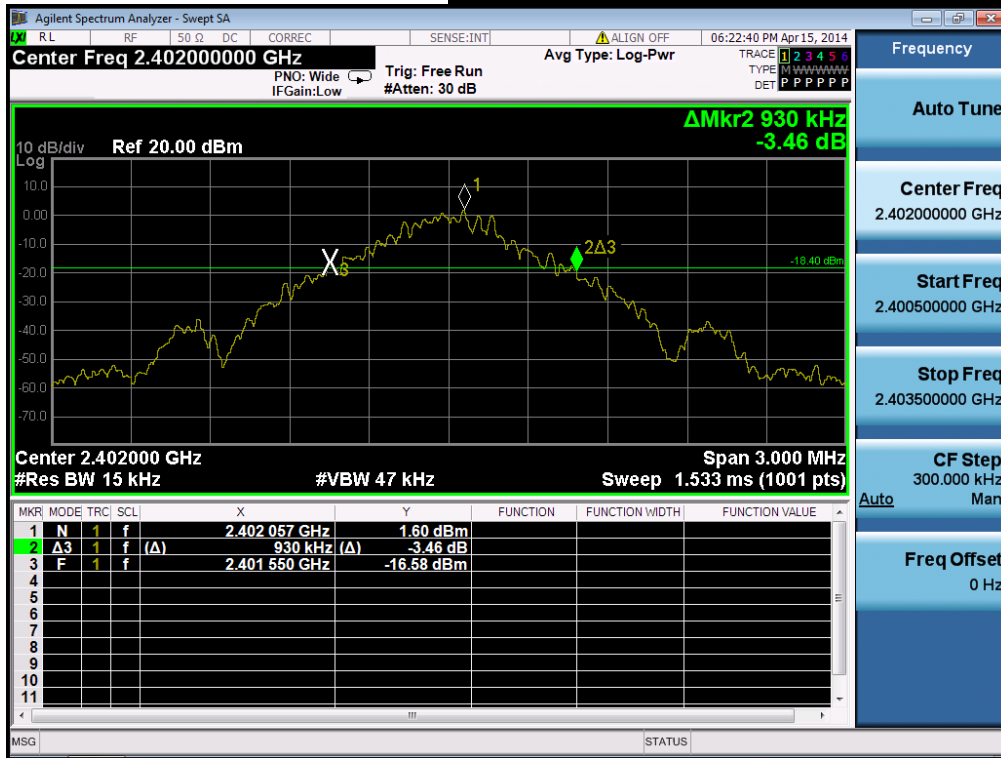

20dBc Bandwidth

Middle Channel & Modulation: GFSK

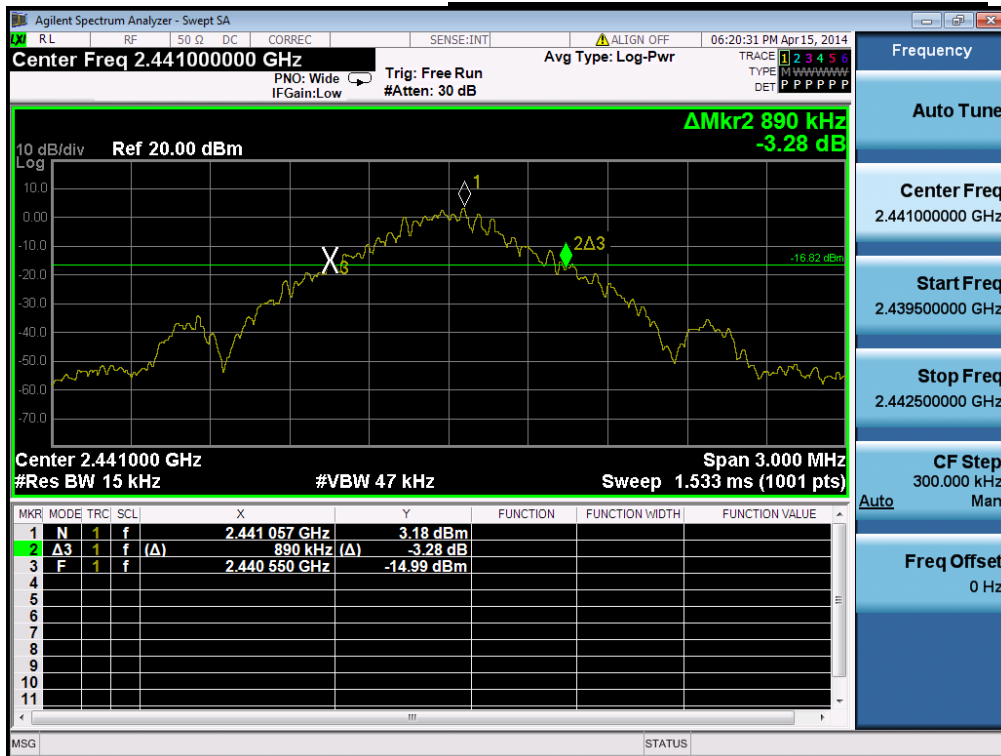

20dBc Bandwidth

Highest Channel&Modulation: GFSK

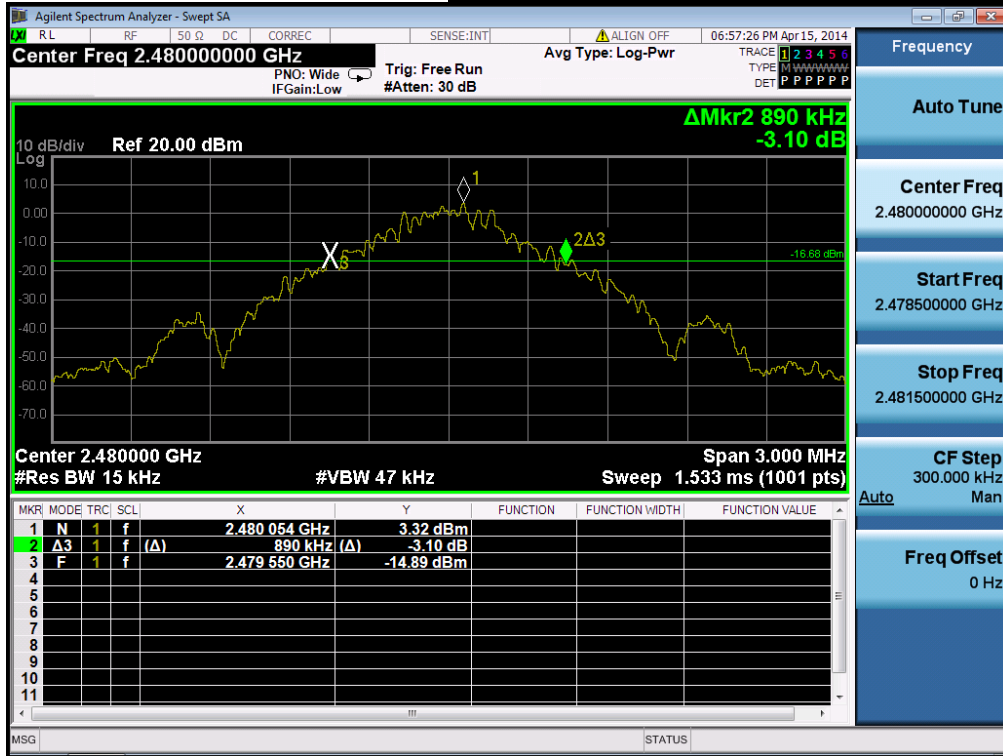

20dBc Bandwidth

Lowest Channel&Modulation: π/4DQPSK



20dBc Bandwidth

Middle Channel & Modulation: $\pi/4$ DQPSK



20dBc Bandwidth

Highest Channel & Modulation: $\pi/4$ DQPSK

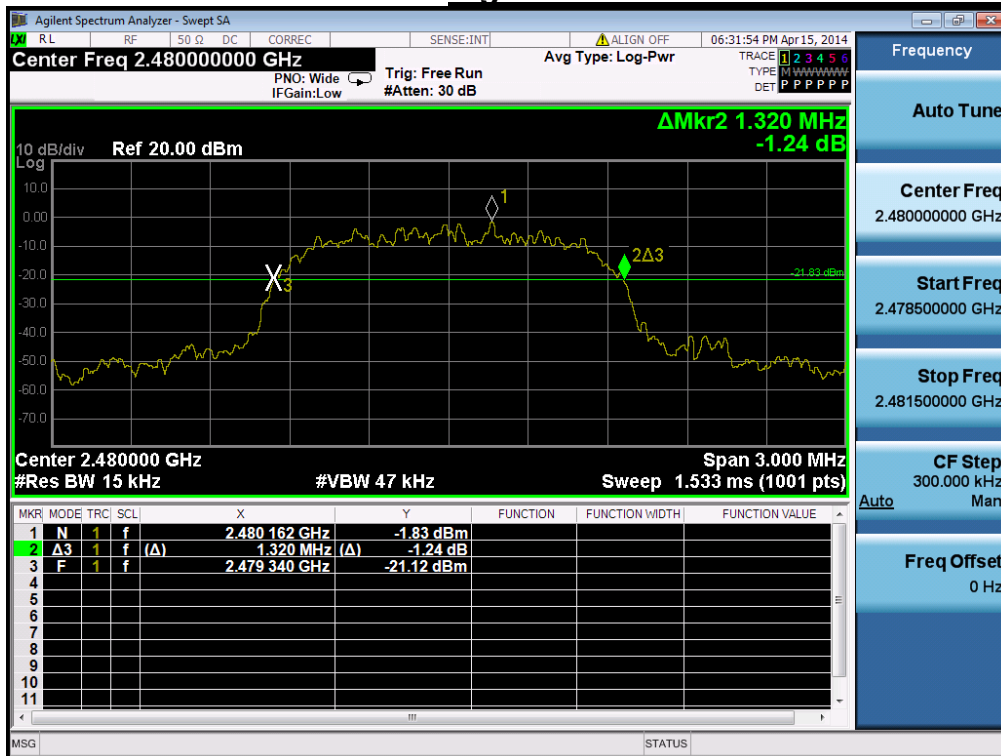

20dBc Bandwidth

Lowest Channel & Modulation: 8DPSK



20dBc Bandwidth

Middle Channel & Modulation: 8DPSK



20dBc Bandwidth

Highest Channel & Modulation: 8DPSK

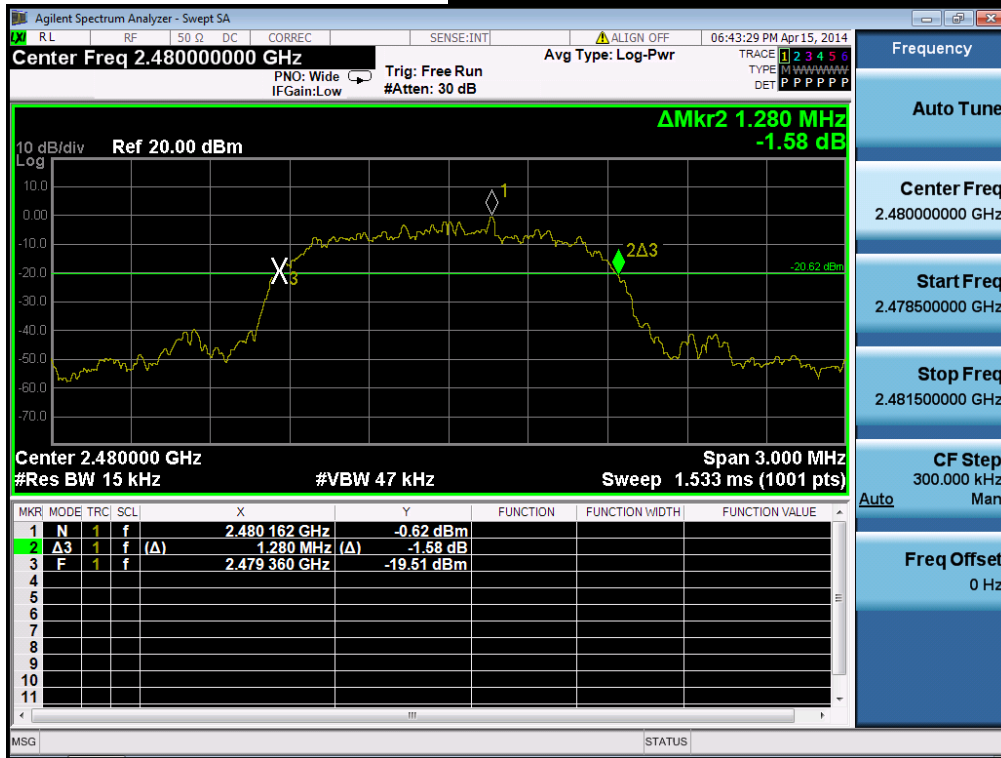

6. Time of Occupancy (Dwell Time)

6.1. Test Setup

Refer to the APPENDIX I.

6.2. Limit

The maximum permissible time of occupancy is 400 ms within a period of 400 ms multiplied by the number of hopping channels employed.

6.3. Test Procedure

The dwell time was measured with a spectrum analyzer connected to the antenna terminal, while EUT had its hopping function enabled.

The spectrum analyzer is set to:

Center frequency = 2441 MHz

RBW = 1 MHz

Trace = max hold

Span = zero

VBW = ≥ RBW

Detector function = peak

6.4. Test Results

Ambient temperature : 25°C
 Relative humidity : 45 %

- FH mode

Hopping mode	Packet Type	Number of hopping Channels	Burst On Time (ms)	Period (ms)	Test Result (sec)
Enable	DH 5	79	2.880	3.750	0.307
	2 DH 5	79	2.880	3.750	0.307
	3 DH 5	79	2.880	3.750	0.307

- AFH mode

Hopping mode	Packet Type	Number of hopping Channels	Burst On Time (ms)	Period (ms)	Test Result (sec)
Enable	DH 5	20	2.880	3.750	0.154
	2 DH 5	20	2.880	3.750	0.154
	3 DH 5	20	2.880	3.750	0.154

Note 1: Dwell Time = $0.4 \times \text{Hopping channel} \times \text{Burst ON time} \times ((\text{Hopping rate} \div \text{Time slots}) \div \text{Hopping channel})$
 - Time slots for DH5 = 6 slots(TX = 5 slot / RX = 1 slot)
 - Hopping Rate = 1600 for FH mode & 800 for AFH mode

Note 2: See next pages for actual measured spectrum plots.

Time of Occupancy (FH)

Hopping mode: Enable&GFSK

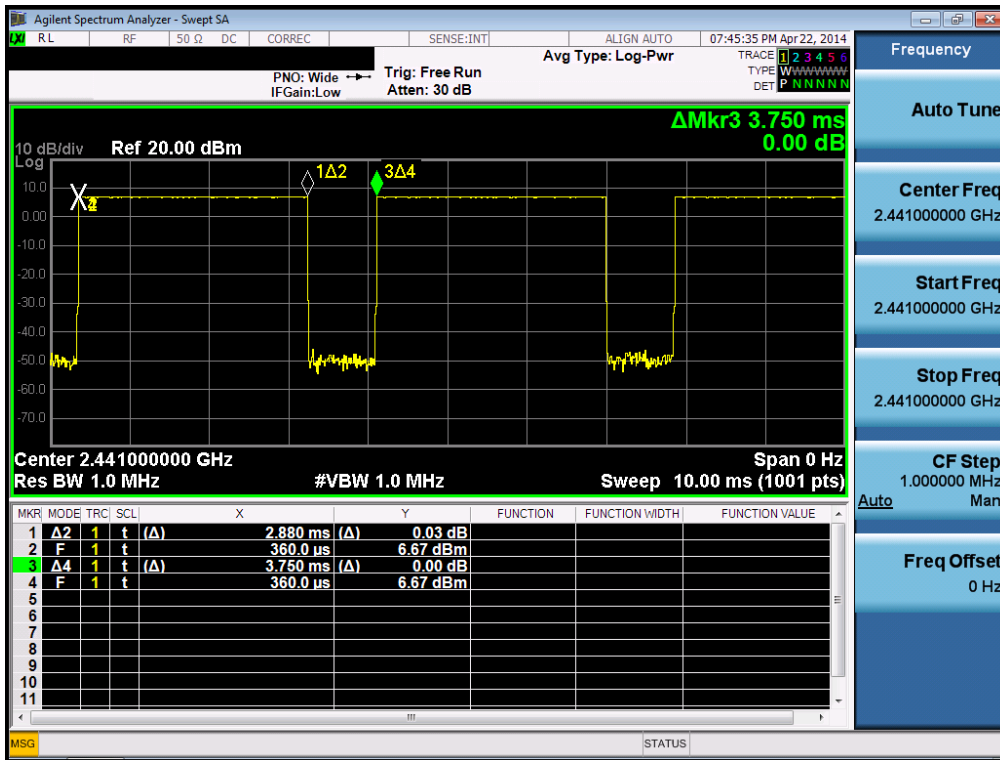

Time of Occupancy (FH)

Hopping mode: Enable& $\pi/4$ -DQPSK

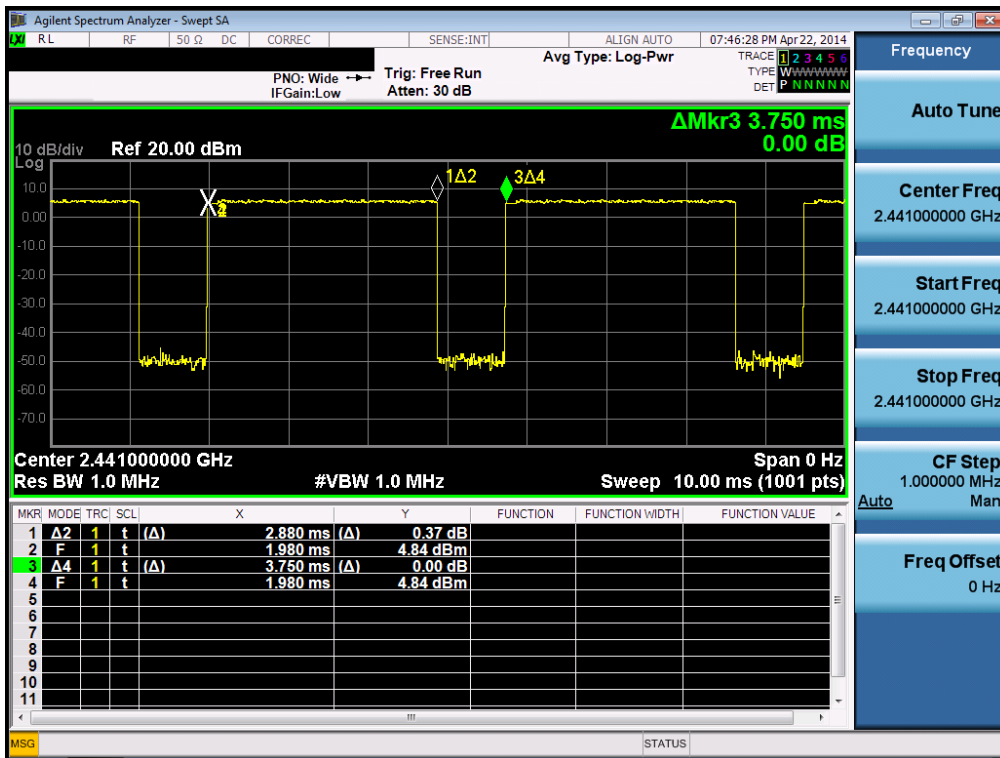

Time of Occupancy (FH)

Hopping mode: Enable&8DPSK

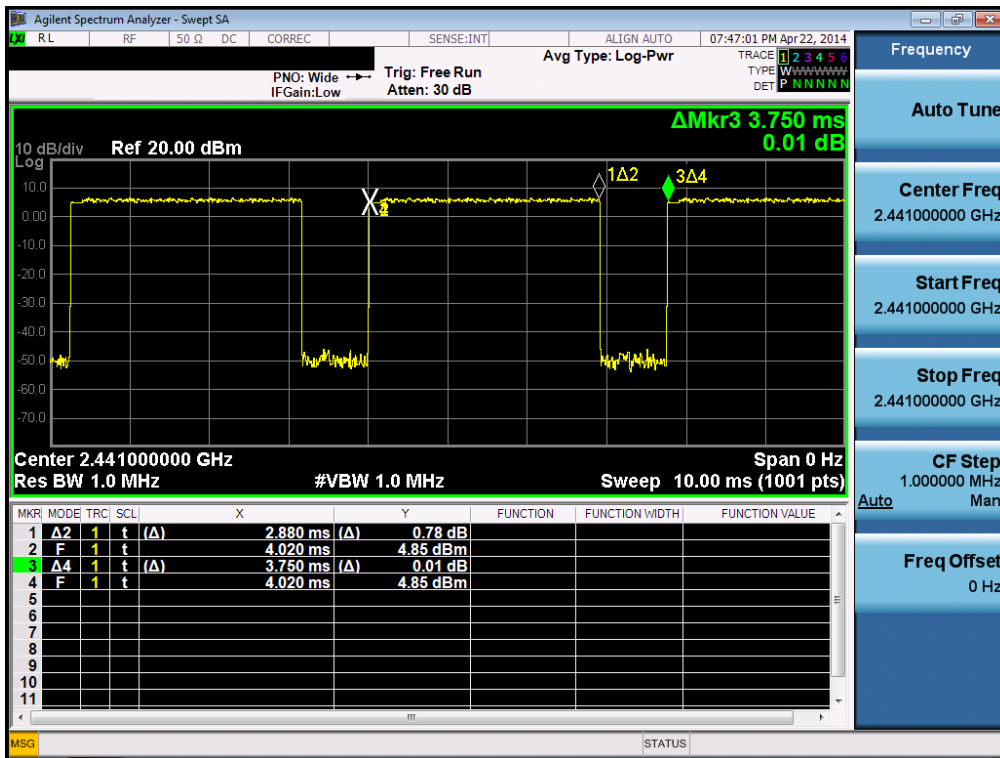

Time of Occupancy (AFH)

Hopping mode: Enable&GFSK

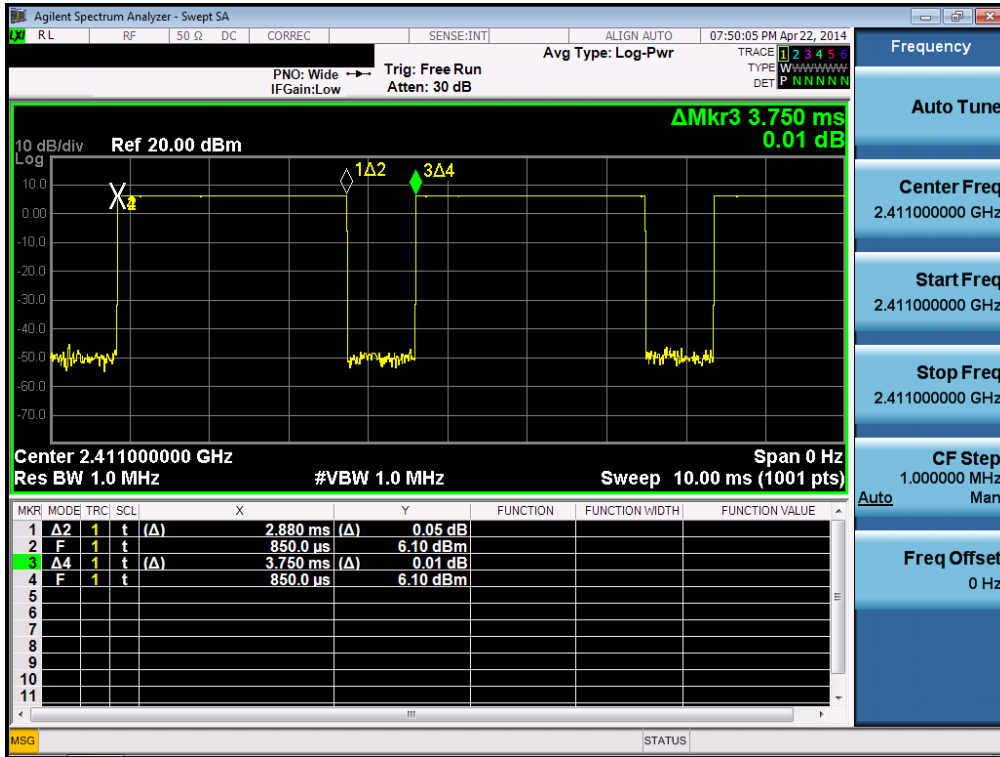

Time of Occupancy (AFH)

Hopping mode: Enable&π/4-DQPSK

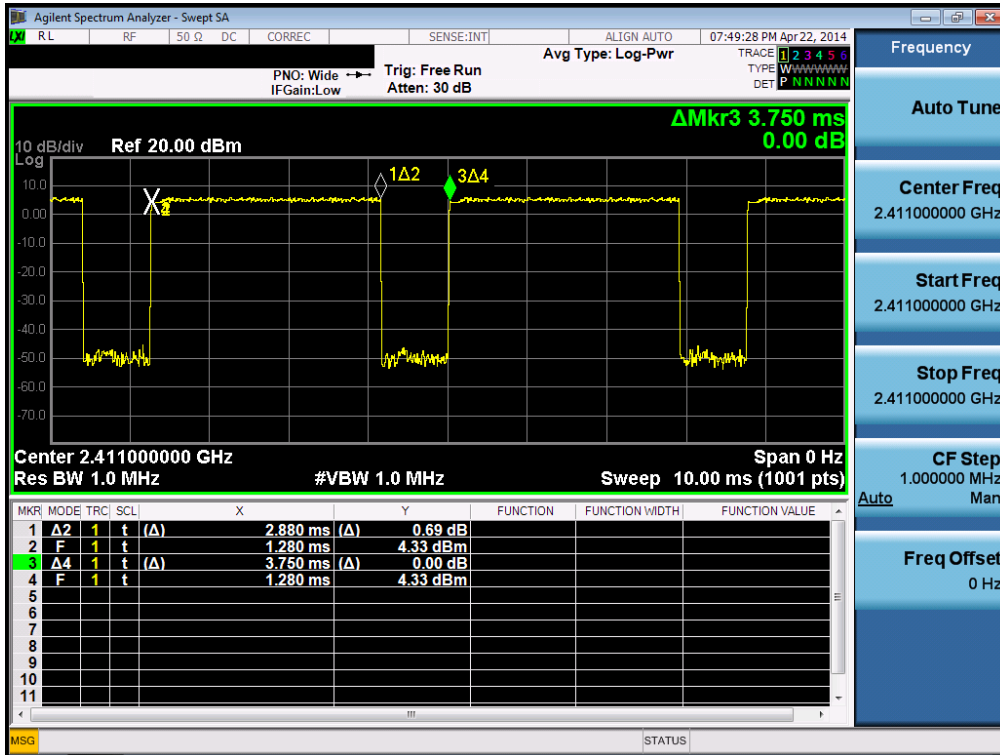

Time of Occupancy (AFH)

Hopping mode: Enable&8DPSK

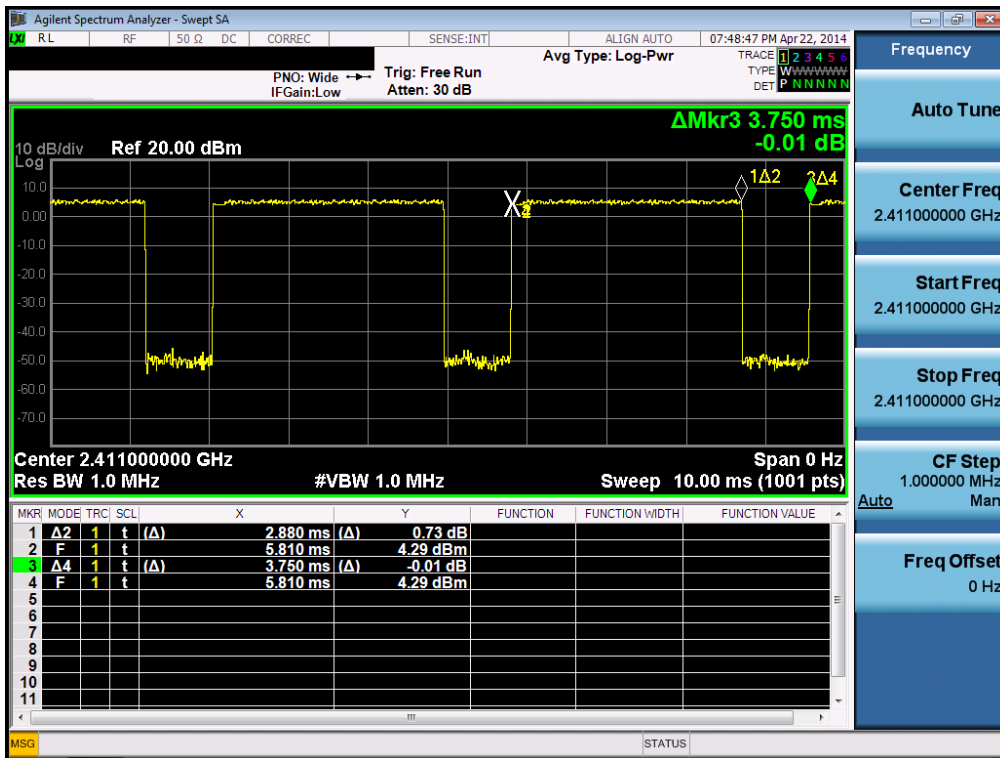

7. Maximum Peak Output Power Measurement

7.1. Test Setup

Refer to the APPENDIX I.

7.2. Limit

The maximum peak output power of the intentional radiator shall not exceed the following :

1. §15.247(a)(1), Frequency hopping systems shall have hopping channel carrier frequencies separated by a minimum of 25 kHz or the 20 dB bandwidth of the hopping channel, whichever is greater, provided the systems operate with an output power no greater than 125 mW.
2. §15.247(b)(1), For frequency hopping systems operating in the 2 400 – 2 483.5 MHz employing at least 75 non-overlapping hopping channels, and all frequency hopping systems in the 5 725 – 5 805 MHz band: 1 Watt.

7.3. Test Procedure

1. The RF power output was measured with a Spectrum analyzer connected to the RF Antenna connector (conducted measurement) while EUT was operating in transmit mode at the appropriate center frequency, A spectrum analyzer was used to record the shape of the transmit signal.
2. The bandwidth of the fundamental frequency was measured with the spectrum analyzer using ;
Span = approximately 5 times of the 20 dB bandwidth, centered on a hopping channel
RBW \geq 20dB BW
VBW \geq RBW
Sweep = auto
Detector function = peak
Trace = max hold

7.4. Test Results

Ambient temperature : 25°C
 Relative humidity : 45 %

Modulation	Tested Channel	Peak Output Power	
		dBm	mW
<u>GFSK</u>	Lowest	5.95	3.936
	Middle	7.88	6.138
	Highest	7.95	6.237
<u>$\pi/4$DQPSK</u>	Lowest	5.96	3.945
	Middle	7.52	5.649
	Highest	7.71	5.902
<u>8DPSK</u>	Lowest	6.35	4.315
	Middle	7.89	6.152
	Highest	8.11	6.471

Note 1: See next pages for actual measured spectrum plots.

Peak Output Power

Lowest Channel & Modulation: GFSK

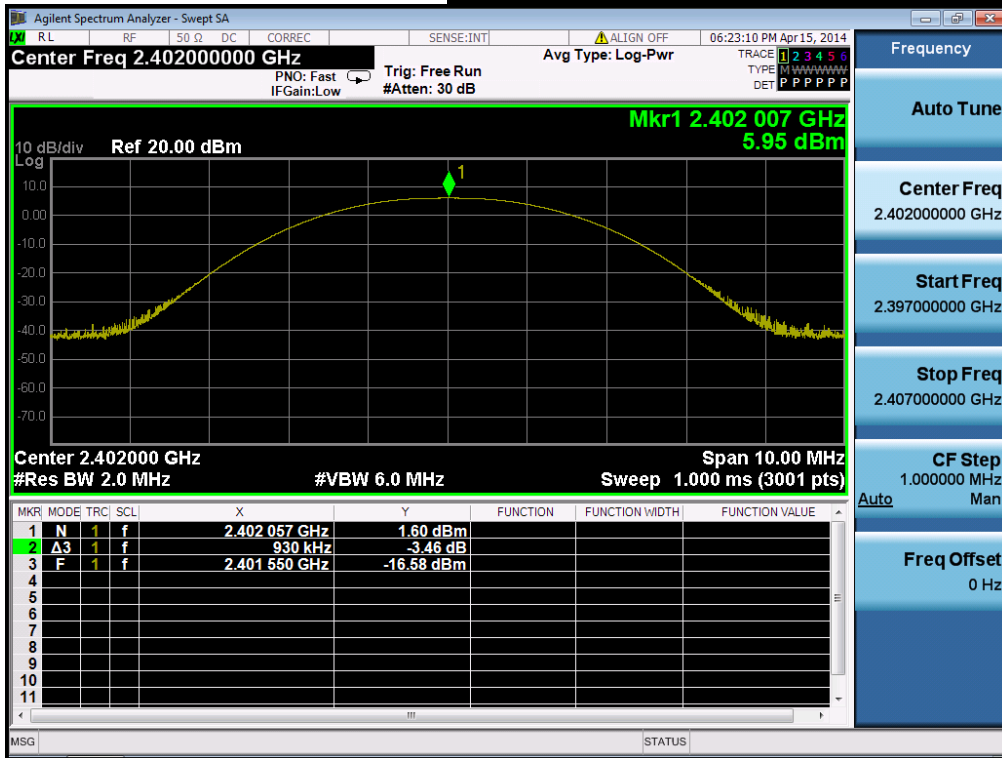

Peak Output Power

Middle Channel & Modulation: GFSK

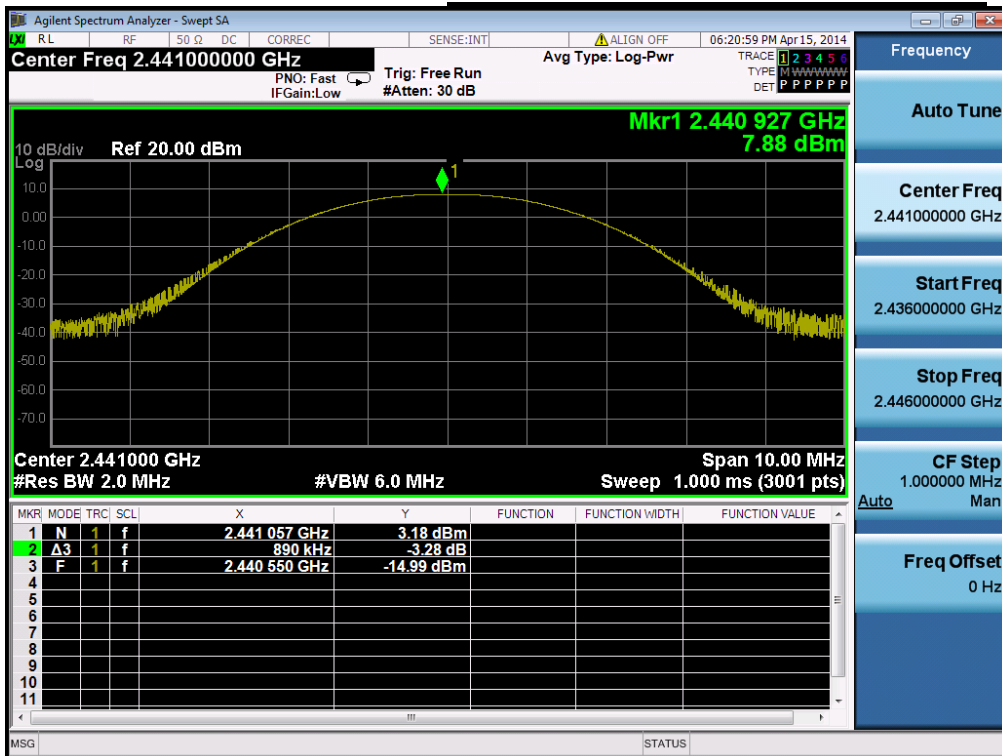

Peak Output Power

Highest Channel & Modulation: GFSK

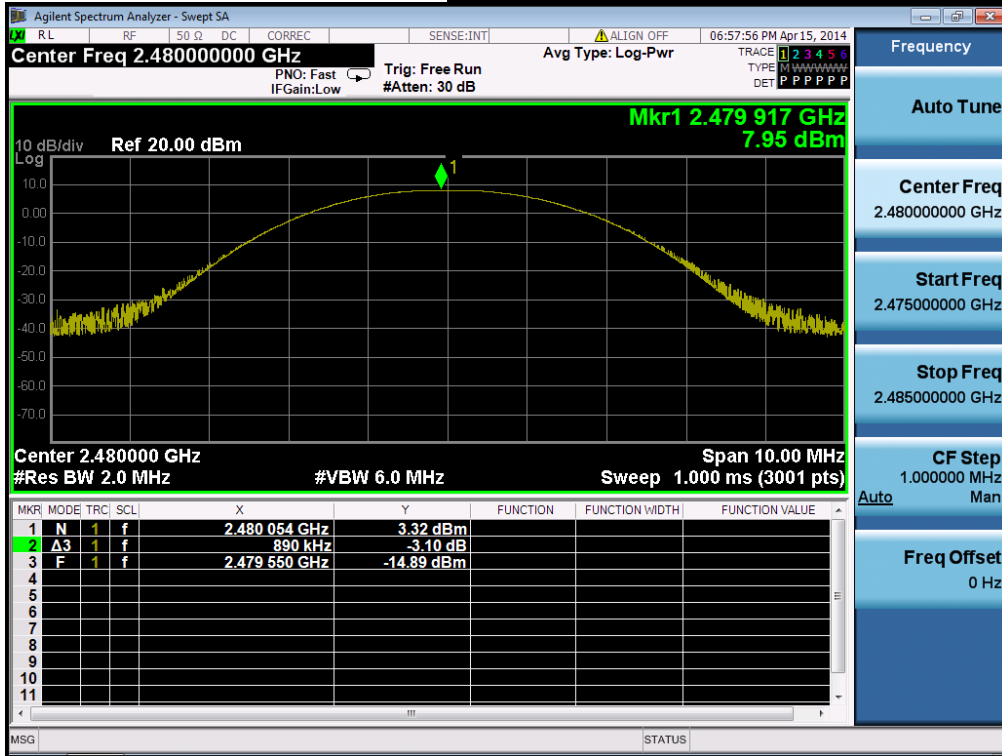

Peak Output Power

Lowest Channel & Modulation: π/4DQPSK

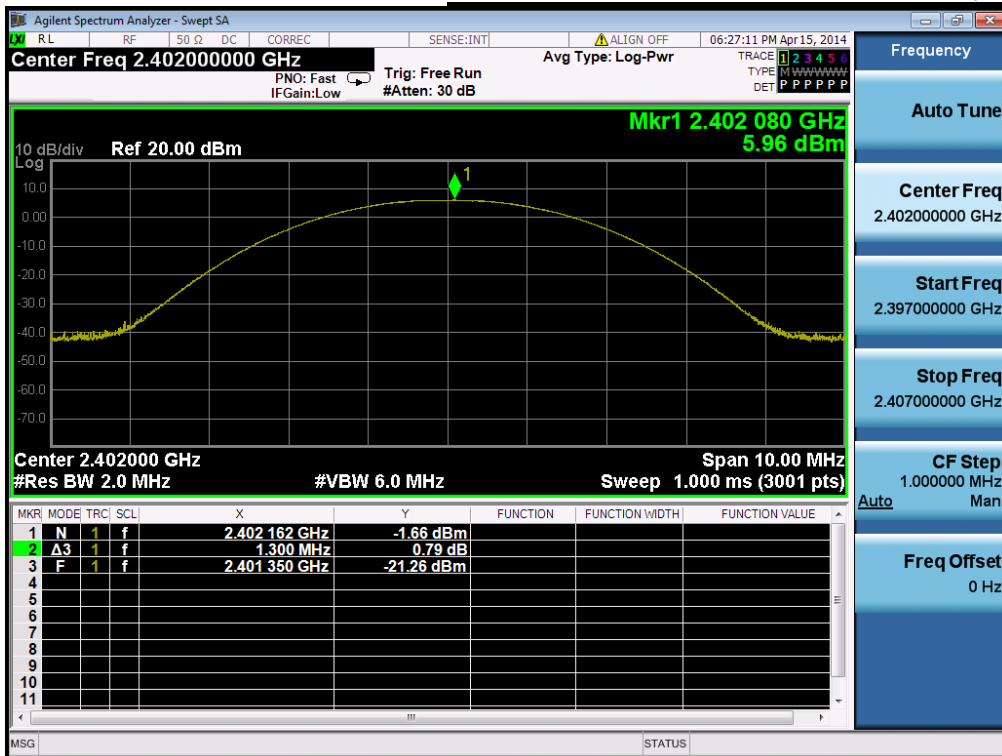

Peak Output Power

Middle Channel & Modulation: $\pi/4$ DQPSK

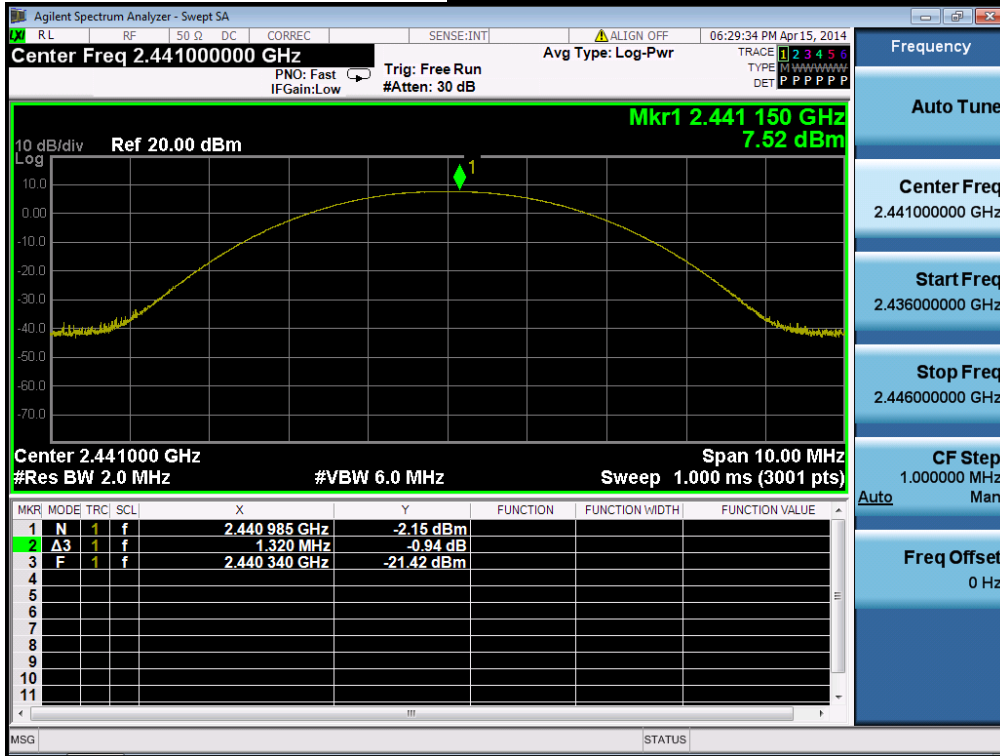

Peak Output Power

Highest Channel & Modulation: $\pi/4$ DQPSK

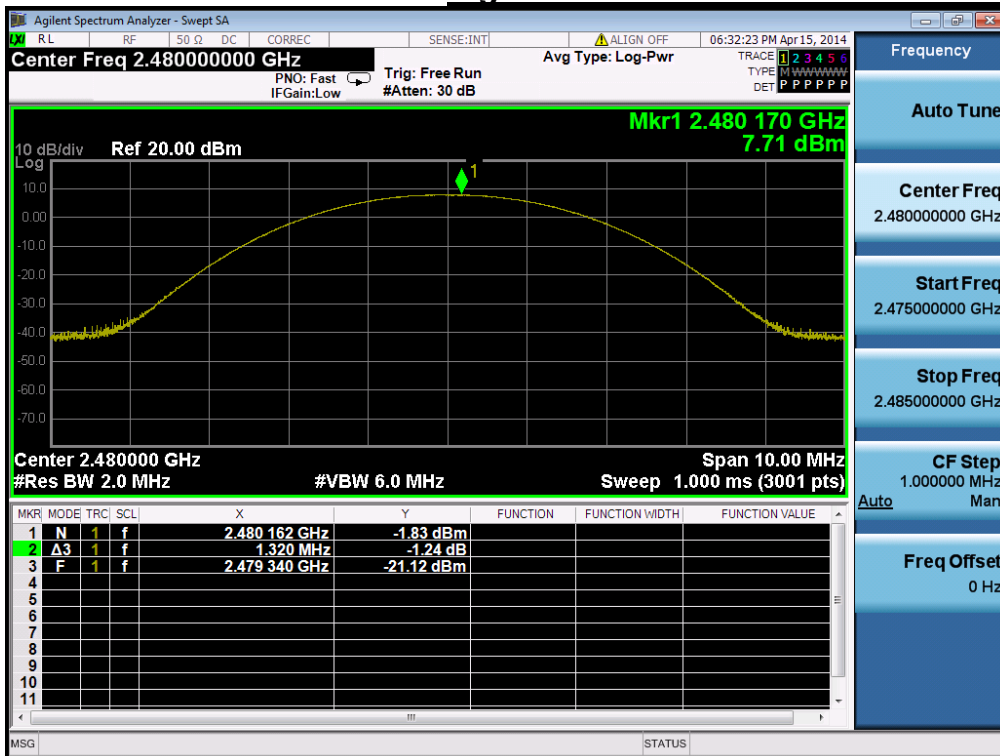

Peak Output Power

Lowest Channel & Modulation: 8DPSK

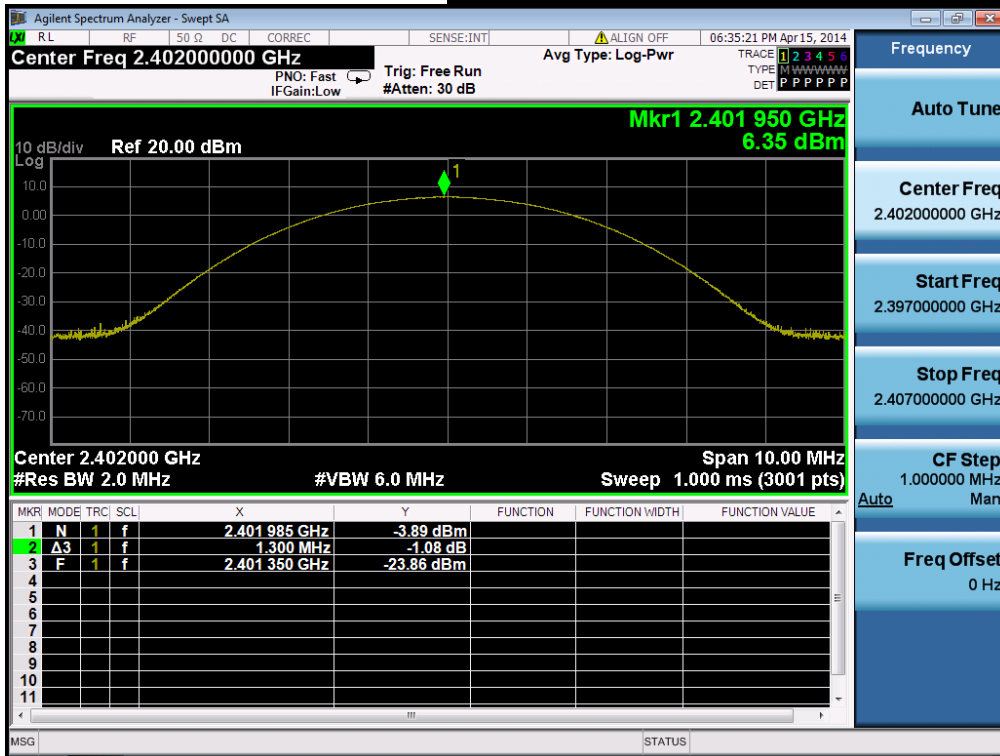

Peak Output Power

Middle Channel & Modulation: 8DPSK

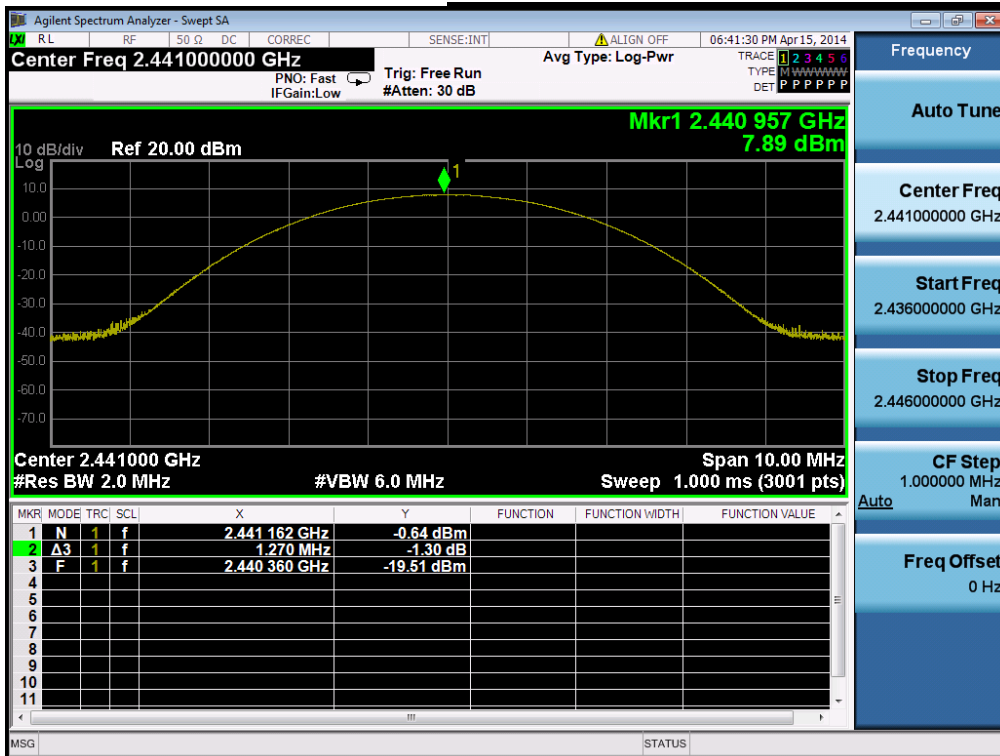

Peak Output Power

Highest Channel & Modulation: 8DPSK

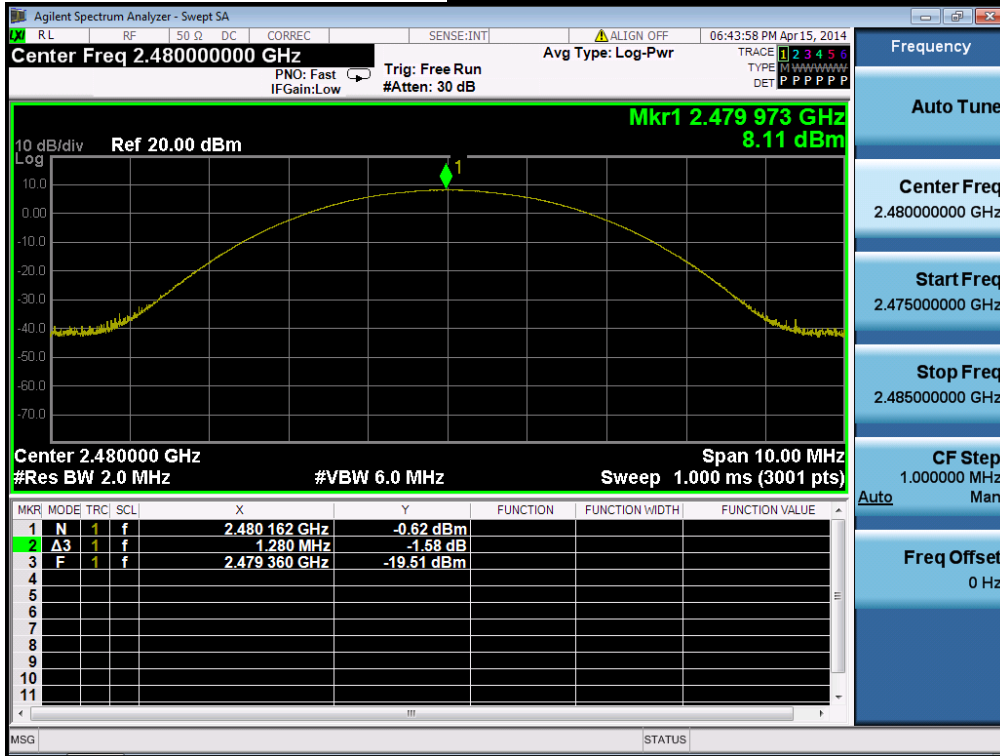

8. Transmitter AC Power Line Conducted Emission

8.1. Test Setup

Refer to test setup photo.

8.2. Limit

According to §15.207(a) for an intentional radiator that is designed to be connected to the public utility (AC) power line, the radio frequency voltage that is conducted back onto the AC power line on any frequency or frequencies, within the band 150 kHz to 30 MHz, shall not exceed the limits in the following table, as measured using a 50 uH/50 ohm line impedance stabilization network(LISN).

Compliance with the provision of this paragraph shall on the measurement of the radio frequency voltage between each power line and ground at the power terminal. The lower applies at the boundary between the frequency ranges.

Frequency Range (MHz)	Conducted Limit (dBuV)	
	Quasi-Peak	Average
0.15 ~ 0.5	66 to 56 *	56 to 46 *
0.5 ~ 5	56	46
5 ~ 30	60	50

* Decreases with the logarithm of the frequency

8.3. Test Procedures

Conducted emissions from the EUT were measured according to the section 6.2 of the ANSI C63.10-2009

1. The test procedure is performed in a 6.5 m × 3.5 m × 3.5 m (L × W × H) shielded room. The EUT along with its peripherals were placed on a 1.0 m (W) × 1.5 m (L) and 0.8 m in height wooden table and the EUT was adjusted to maintain a 0.4 meter space from a vertical reference plane.
2. The EUT was connected to power mains through a line impedance stabilization network (LISN) which provides 50 ohm coupling impedance for measuring instrument and the chassis ground was bounded to the horizontal ground plane of shielded room.
3. All peripherals were connected to the second LISN and the chassis ground also bounded to the horizontal ground plane of shielded room.
4. The excess power cable between the EUT and the LISN was bundled. The power cables of peripherals were unbundled. All connecting cables of EUT and peripherals were moved to find the maximum emission.

8.4. Test Results

AC Line Conducted Emissions (Graph)&Modulation: GFSK

Results of Conducted Emission

Digital EMC
 Date : 2014-04-24

Model No.	: LG-D150g	Reference No.	:
Type	:	Power Supply	: 120 V 60 Hz
Serial No.	: Identical prototype	Temp/Humi.	: 21 'C 40 % R.H.
Test Condition	: BT	Operator	: C.M.KIM
Memo	: HOPPING		

LIMIT : FCC P15.207 QP
 FCC P15.207 AV

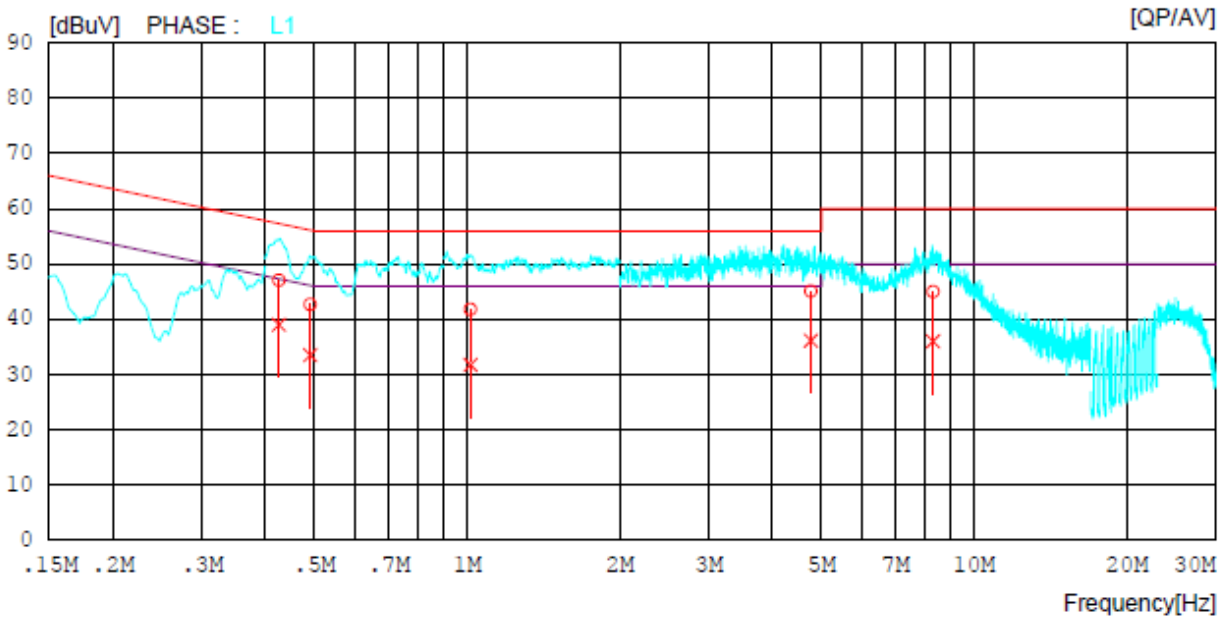
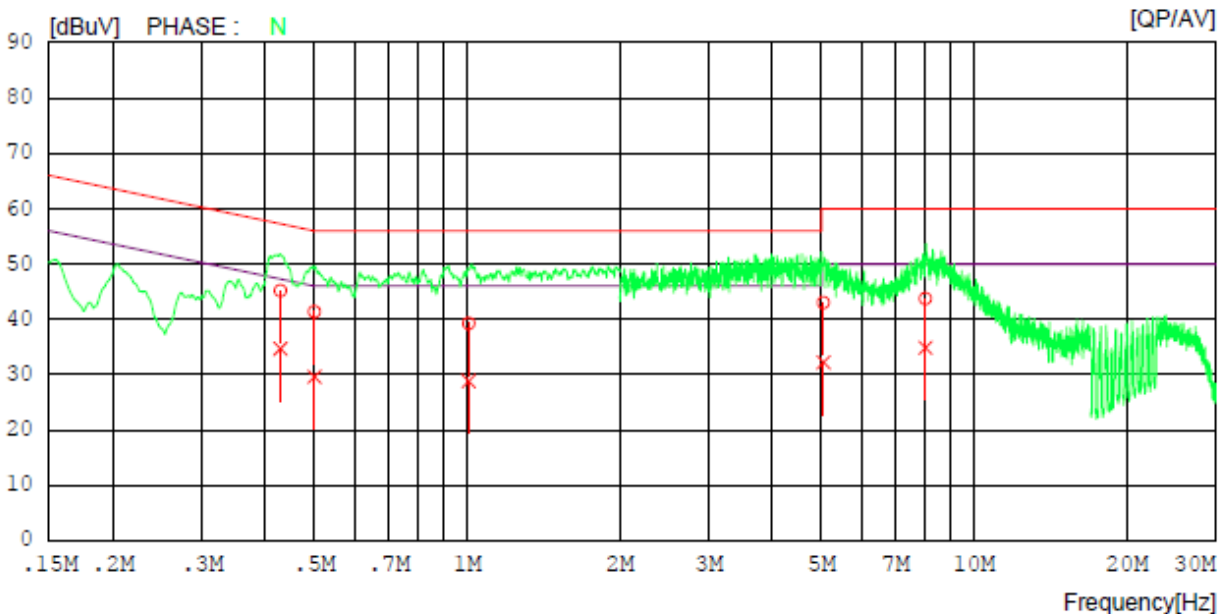

AC Line Conducted Emissions (List)&Modulation: GFSK

Results of Conducted Emission

Digital EMC
 Date : 2014-04-24

Model No.	: LG-D150g	Reference No.	:
Type	:	Power Supply	: 120 V 60 Hz
Serial No.	: Identical prototype	Temp/Humi.	: 21 'C 40 % R.H.
Test Condition	: BT	Operator	: C.M.KIM

Memo : HOPPING

LIMIT : FCC P15.207 QP
 FCC P15.207 AV

NO	FREQ [MHz]	READING		C.FACTOR [dB]	RESULT		LIMIT		MARGIN		PHASE
		QP [dBuV]	AV [dBuV]		QP [dBuV]	AV [dBuV]	QP [dBuV]	AV [dBuV]			
1	0.42849	35.0	24.5	10.2	45.2	34.7	57.3	47.3	12.1	12.6	N
2	0.49997	31.2	19.4	10.2	41.4	29.6	56.0	46.0	14.6	16.4	N
3	1.00753	29.0	18.5	10.3	39.3	28.8	56.0	46.0	16.7	17.2	N
4	5.04740	32.6	21.8	10.4	43.0	32.2	60.0	50.0	17.0	17.8	N
5	8.02506	33.3	24.4	10.4	43.7	34.8	60.0	50.0	16.3	15.2	N
6	0.42551	36.8	28.7	10.3	47.1	39.0	57.3	47.3	10.2	8.3	L1
7	0.49052	32.4	23.3	10.3	42.7	33.6	56.2	46.2	13.5	12.6	L1
8	1.01564	31.5	21.5	10.3	41.8	31.8	56.0	46.0	14.2	14.2	L1
9	4.76720	34.7	25.8	10.4	45.1	36.2	56.0	46.0	10.9	9.8	L1
10	8.30892	34.5	25.5	10.5	45.0	36.0	60.0	50.0	15.0	14.0	L1

9. Antenna Requirement

■ **Procedure:**

Describe how the EUT complies with the requirement that either its antenna is permanently attached, or that it employs a unique antenna connector, for every antenna proposed for use with the EUT.

■ **Conclusion: Comply**

The internal antenna is attached on the main PCB using the special spring tension. (Refer to Internal Photo file.)

■ **Minimum Standard:**

An intentional radiator shall be designed to ensure that no antenna other than that furnished by the responsible party shall be used with the device. The use of a permanently attached antenna or of an antenna that uses a unique coupling to the intentional radiator shall be considered sufficient to comply with the provisions.

10. Occupied Bandwidth(99%)

- **Procedure:(RSS-Gen Issue 3)**

- The 99% power bandwidth was measured with a calibrated spectrum analyzer.
- Spectrum analyzer plots are included on the following pages.

- **Measurement Data: NA**

- **Minimum Standard:**

N/A

APPENDIX I

Test set up Diagrams & Path loss Information

▪Radiated Measurement

The diagram below shows the test setup that is utilized to make the measurements for emission from 9kHz to 25GHz Emissions.

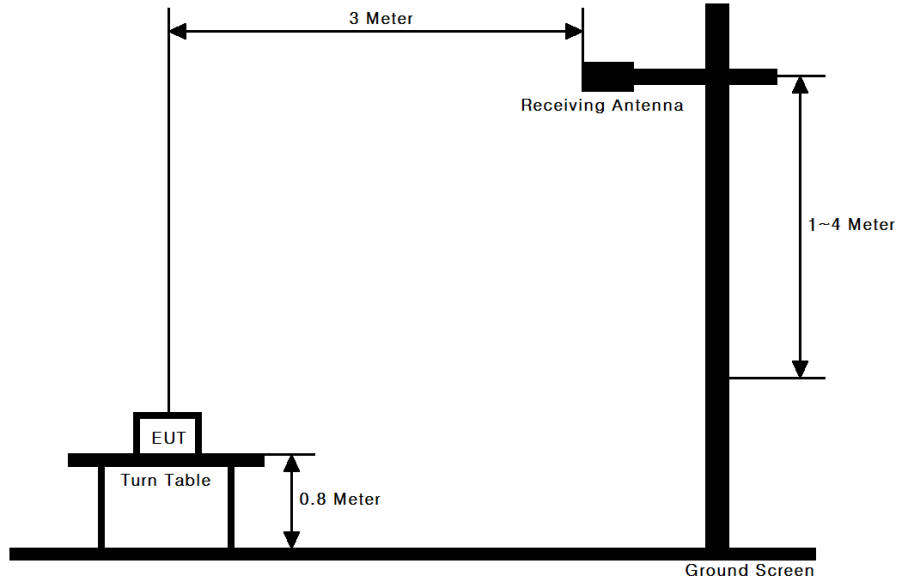

▪Conducted Measurement

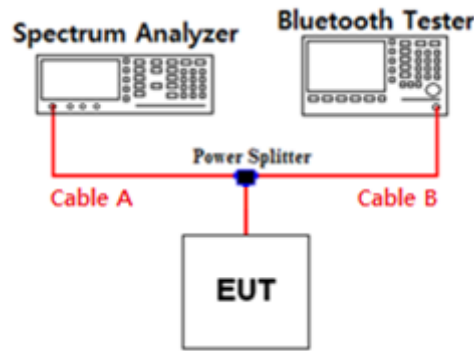

Path loss information

Frequency (GHz)	Path Loss (dB)	Frequency (GHz)	Path Loss (dB)
0.03	5.71	15	8.38
1	6.06	20	8.52
2.402 & 2.441 & 2.480	6.48	25	9.30
5	7.10	-	-
10	8.10	-	-

Note. 1: The path loss from EUT to Spectrum analyzer was measured and used for test.
 Path loss (=S/A's Correction factor) = Cable A + Power splitter