

FCC Test Report

APPLICANT : LG Electronics Inc.
EQUIPMENT : WCDMA & LTE Wireless Router with WLAN
BRAND NAME : LG
MODEL NAME : CR820
MARKETING NAME : CR820
FCC ID : ZNFCR820
STANDARD : FCC 47 CFR FCC Part 15 Subpart B
CLASSIFICATION : Certification

The product was received on Mar. 04, 2013 and completely tested on Mar. 06, 2013. We, SPORTON INTERNATIONAL INC., would like to declare that the tested sample has been evaluated in accordance with the procedures given in ANSI C63.4-2009 and shown the compliance with the applicable technical standards.

The test results in this report apply exclusively to the tested model / sample. Without written approval of SPORTON INTERNATIONAL INC., the test report shall not be reproduced except in full.

Reviewed by:



Louis Wu / Manager

Reviewed by:



Jones Tsai / Manager



SPORTON INTERNATIONAL INC.

No. 52, Hwa Ya 1st Rd., Hwa Ya Technology Park, Kwei-Shan Hsiang, Tao Yuan Hsien, Taiwan, R.O.C.



TABLE OF CONTENTS

REVISION HISTORY 3

SUMMARY OF TEST RESULT 4

1. GENERAL DESCRIPTION 5

 1.1. Applicant..... 5

 1.2. Manufacturer 5

 1.3. Feature of Equipment Under Test..... 5

 1.4. Product Specification of Equipment Under Test 5

 1.5. Test Site 6

 1.6. Applied Standards 6

2. TEST CONFIGURATION OF EQUIPMENT UNDER TEST 7

 2.1. Test Mode 7

 2.2. Connection Diagram of Test System 9

 2.3. Support Unit used in test configuration and system 10

 2.4. Test Software 10

3. TEST RESULT 11

 3.1. Test of AC Conducted Emission Measurement 11

 3.2. Test of Radiated Emission Measurement 15

4. LIST OF MEASURING EQUIPMENT 19

5. UNCERTAINTY OF EVALUATION 20

APPENDIX A. PHOTOGRAPHS OF EUT

APPENDIX B. SETUP PHOTOGRAPHS



REVISION HISTORY

REPORT NO.	VERSION	DESCRIPTION	ISSUED DATE
FC330402	Rev. 01	Initial issue of report	Apr. 03, 2013



SUMMARY OF TEST RESULT

Report Section	FCC Rule	IC Rule	Description	Limit	Result	Remark
3.1	15.107	7.2.4	AC Conducted Emission	< 15.107 limits < RSS-Gen table 2 limits	PASS	Under limit 8.40 dB at 0.190 MHz
3.2	15.109	7.2.3.2	Radiated Emission	< 15.109 limits < RSS-Gen table 1 limits	PASS	Under limit 7.12 dB at 30.810 MHz

1. General Description

1.1. Applicant

LG Electronics Inc.
60-39, Kasan-dong, Kumchon-gu, Seoul 135-801, Korea

1.2. Manufacturer

LG Electronics Inc.
60-39, Kasan-dong, Kumchon-gu, Seoul 135-801, Korea

1.3. Feature of Equipment Under Test

Product Feature	
Equipment	WCDMA & LTE Wireless Router with WLAN
Brand Name	LG
Model Name	CR820
Marketing Name	CR820
FCC ID	ZNFCR820
EUT supports Radios application	WCDMA/HSPA/LTE/WLAN 11bgn
HW Version	Rev.1.0
SW Version	V08a
EUT Stage	Production Unit

Remark: The above EUT's information was declared by manufacturer. Please refer to the specifications or user's manual for more detailed description.

1.4. Product Specification of Equipment Under Test

Product Specification subjective to this standard	
Tx Frequency	WCDMA Band V: 826.4 MHz ~ 846.6 MHz WCDMA Band II: 1852.4 MHz ~ 1907.6 MHz LTE Band 7: 2502.5 MHz ~ 2567.5 MHz 802.11b/g/n: 2412 MHz ~ 2462 MHz
Rx Frequency Range	WCDMA Band V: 871.4 MHz ~ 891.6 MHz WCDMA Band II: 1932.4 MHz ~ 1987.6 MHz LTE Band 7: 2622.5 MHz ~ 2687.5 MHz 802.11b/g/n: 2412 MHz ~ 2462 MHz
Antenna Type	WWAN : PIFA Antenna LTE : PIFA Antenna WLAN : PIFA Antenna
Type of Modulation	WCDMA: QPSK (Uplink) HSDPA: QPSK (Uplink) HSUPA: QPSK (Uplink) 802.11b : DSSS (DBPSK / DQPSK / CCK) 802.11g/n : OFDM (BPSK / QPSK / 16QAM / 64QAM)

1.5. Test Site

Test Site	SPORTON INTERNATIONAL INC.		
Test Site Location	No. 52, Hwa Ya 1 st Rd., Hwa Ya Technology Park, Kwei-Shan Hsiang, Tao Yuan Hsien, Taiwan, R.O.C. TEL: +886-3-327-3456 FAX: +886-3-328-4978		
Test Site No.	Sporton Site No.		FCC/IC Registration No.
	CO05-HY	03CH06-HY	722060/4086B-1

1.6. Applied Standards

According to the specifications of the manufacturer, the EUT must comply with the requirements of the following standards:

- ♦ FCC 47 CFR FCC Part 15 Subpart B
- ♦ ANSI C63.4-2009

Remark: All test items were verified and recorded according to the standards and without any deviation during the test.

2. Test Configuration of Equipment Under Test

2.1. Test Mode

The EUT has been associated with peripherals pursuant to ANSI C63.4-2009 and configuration operated in a manner tended to maximize its emission characteristics in a typical application.

Frequency range investigated: conduction (150 KHz to 30 MHz), radiation (30MHz to the 5th harmonic of the highest fundamental frequency or to 40 GHz, whichever is lower).

The following tables are showing the test modes as the worst cases and recorded in this report.

Item	EUT Configuration	Test Condition		
		EMI AC	EMI RE<1G	EMI RE≥1G
1.	Charging Mode (EUT with adapter)	☒	☒	☒
2.	Charging Mode (EUT with notebook)	☒	☒	Note 1

Abbreviations:

- EMI AC: AC conducted emissions
- EMI RE ≥ 1G: EUT radiated emissions ≥ 1GHz
- EMI RE < 1G: EUT radiated emissions < 1GHz

Note 1: Testing for this mode is not required or not the worst case.

Remark: For signal above 1GHz, the worst case was test item 1.

Test Items	EUT Configure Mode	Function Type
AC Conducted Emission	1/2	Mode 1 : WCDMA Band V Idle + WLAN Idle + USB Cable (Charging from Adapter) Mode 2 : WCDMA Band II Idle + WLAN Idle + USB Cable (Charging from Adapter) Mode 3 : LTE Band 7 Idle + WLAN Idle + USB Cable (Charging from Notebook)
Radiated Emissions < 1GHz	1/2	Mode 1 : WCDMA Band V Idle + WLAN Idle + USB Cable (Charging from Adapter) Mode 2 : WCDMA Band II Idle + WLAN Idle + USB Cable (Charging from Adapter) Mode 3 : LTE Band 7 Idle + WLAN Idle + USB Cable (Charging from Notebook)
Radiated Emissions ≥ 1GHz	1	Mode 1 : WCDMA Band II Idle + WLAN Idle + USB Cable (Charging from Adapter)
Remark: <ol style="list-style-type: none"> 1. The worst case of AC is mode 3; only the test data of this mode was reported. 2. The worst case of RE < 1G is mode 2; only the test data of this mode was reported. 		

2.2. Connection Diagram of Test System

<EUT with Adapter Mode>

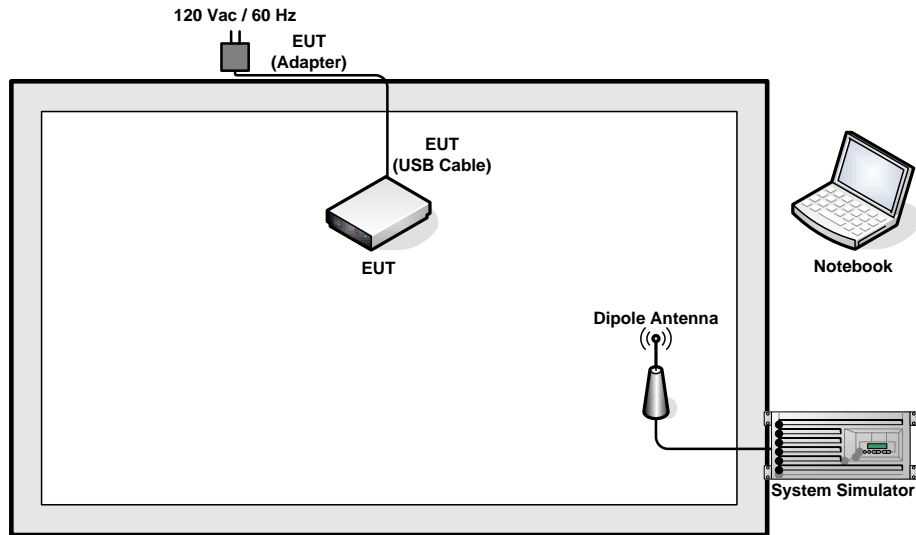

<EUT with USB Cable (Charging from Notebook) Mode>

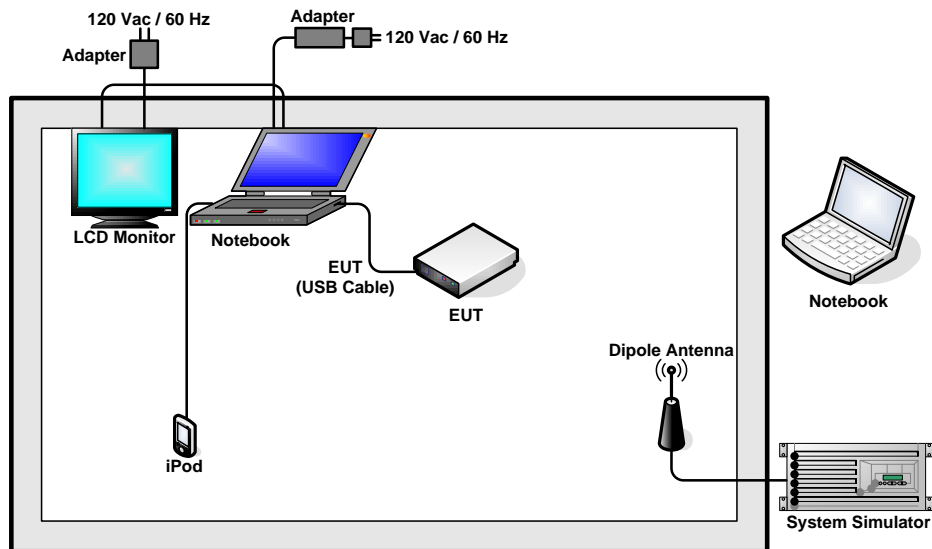

2.3. Support Unit used in test configuration and system

Item	Equipment	Trade Name	Model Name	FCC ID	Data Cable	Power Cord
1.	System Simulator	R&S	CMU 200	N/A	N/A	Unshielded, 1.8 m
2.	System Simulator	Anritsu	8820C	N/A	N/A	Unshielded, 1.8 m
3.	Notebook	DELL	Latitude E6320	FCC DoC	N/A	AC I/P: Unshielded, 1.2 m DC O/P: Shielded, 1.8 m
4.	LCD Monitor	Dell	U2410	FCC DoC	Shielded, 1.6 m	Unshielded, 1.8 m
5.	iPod	Apple	A1285	FCC DoC	Shielded, 1.0 m	N/A
6.	SD Card	SanDisk	16G Class 10	FCC DoC	N/A	N/A

2.4. Test Software

The EUT was in WCDMA and LTE idle mode during the testing. The EUT was synchronized to the BCCH, and was in continuous receiving mode by setting system simulator's paging reorganization.

3. Test Result

3.1. Test of AC Conducted Emission Measurement

3.1.1 Limits of AC Conducted Emission

For equipment that is designed to be connected to the public utility (AC) power line, the radio frequency voltage that is conducted back onto the AC power line on any frequency or frequencies within the band 150 KHz to 30 MHz shall not exceed the limits in the following table.

Frequency of emission (MHz)	Conducted limit (dBuV)	
	Quasi-peak	Average
0.15-0.5	66 to 56*	56 to 46*
0.5-5	56	46
5-30	60	50

*Decreases with the logarithm of the frequency.

3.1.2 Measuring Instruments

See list of measuring instruments of this test report.

3.1.3 Test Procedure

1. The EUT was placed 0.4 meter from the conducting wall of the shielding room was kept at least 80 centimeters from any other grounded conducting surface.
2. Connect EUT to the power mains through a line impedance stabilization network (LISN).
3. All the support units are connecting to the other LISN.
4. The LISN provides 50 ohm coupling impedance for the measuring instrument.
5. The FCC states that a 50 ohm, 50 microhenry LISN should be used.
6. Both sides of AC line were checked for maximum conducted interference.
7. The frequency range from 150 KHz to 30 MHz was searched.
8. Set the test-receiver system to Peak Detect Function and specified bandwidth with Maximum Hold Mode.

3.1.4 Test Setup

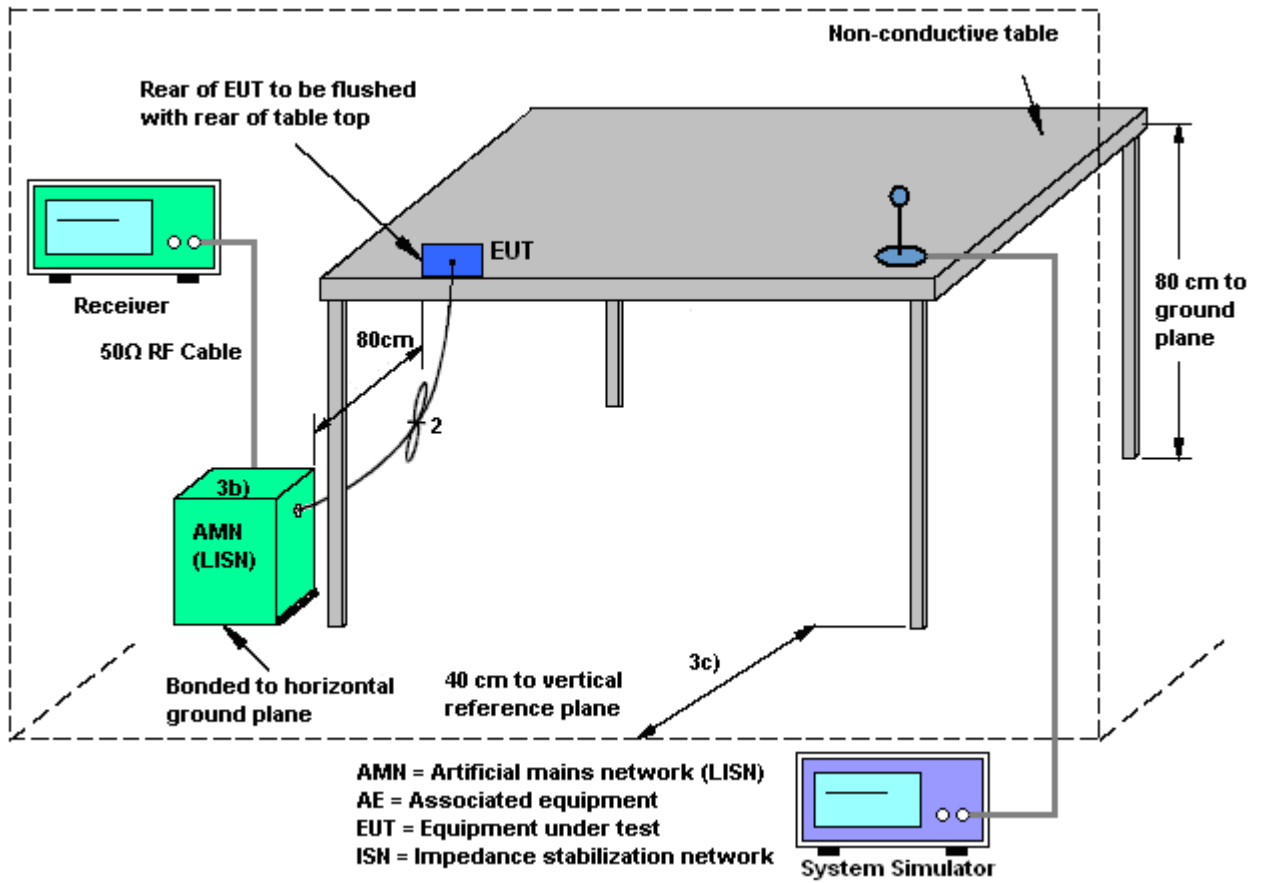

3.1.5 Test Result of AC Conducted Emission

Test Mode :	Mode 3	Temperature :	20~22°C
Test Engineer :	Slash Huang	Relative Humidity :	45~47%
Test Voltage :	120Vac / 60Hz	Phase :	Line
Function Type :	LTE Band 7 Idle + WLAN Idle + USB Cable (Charging from Notebook)		
Remark :	All emissions not reported here are more than 10 dB below the prescribed limit.		

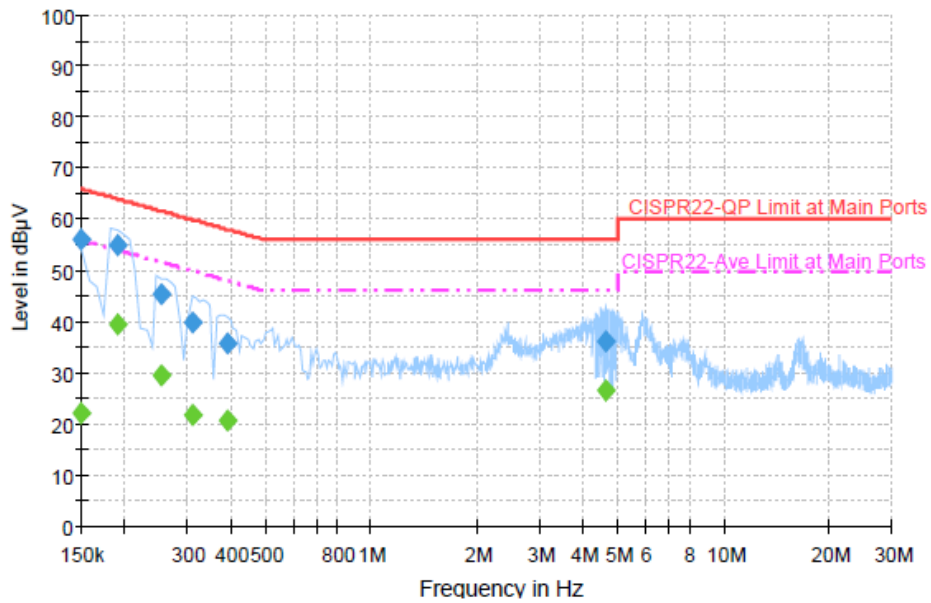

Final Result : Quasi-Peak

Frequency (MHz)	Quasi-Peak (dBµV)	Filter	Line	Corr. (dB)	Margin (dB)	Limit (dBµV)
0.150000	56.0	Off	L1	19.4	10.0	66.0
0.190000	55.1	Off	L1	19.4	8.9	64.0
0.254000	45.2	Off	L1	19.4	16.4	61.6
0.310000	39.9	Off	L1	19.4	20.1	60.0
0.390000	35.8	Off	L1	19.4	22.3	58.1
4.606000	36.0	Off	L1	19.7	20.0	56.0

Final Result : Average

Frequency (MHz)	Average (dBµV)	Filter	Line	Corr. (dB)	Margin (dB)	Limit (dBµV)
0.150000	22.3	Off	L1	19.4	33.7	56.0
0.190000	39.4	Off	L1	19.4	14.6	54.0
0.254000	29.5	Off	L1	19.4	22.1	51.6
0.310000	21.7	Off	L1	19.4	28.3	50.0
0.390000	20.8	Off	L1	19.4	27.3	48.1
4.606000	26.5	Off	L1	19.7	19.5	46.0

Test Mode :	Mode 3	Temperature :	20~22°C
Test Engineer :	Slash Huang	Relative Humidity :	45~47%
Test Voltage :	120Vac / 60Hz	Phase :	Neutral
Function Type :	LTE Band 7 Idle + WLAN Idle + USB Cable (Charging from Notebook)		
Remark :	All emissions not reported here are more than 10 dB below the prescribed limit.		

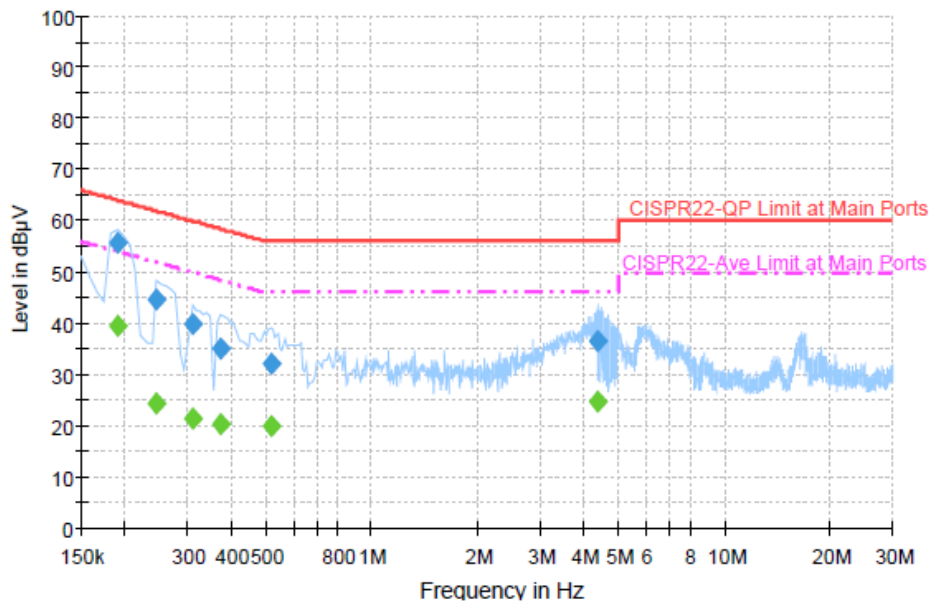

Final Result : Quasi-Peak

Frequency (MHz)	Quasi-Peak (dBµV)	Filter	Line	Corr. (dB)	Margin (dB)	Limit (dBµV)
0.190000	55.6	Off	N	19.4	8.4	64.0
0.246000	44.8	Off	N	19.4	17.1	61.9
0.310000	39.8	Off	N	19.4	20.2	60.0
0.374000	34.9	Off	N	19.4	23.5	58.4
0.518000	32.1	Off	N	19.4	23.9	56.0
4.398000	36.4	Off	N	19.7	19.6	56.0

Final Result : Average

Frequency (MHz)	Average (dBµV)	Filter	Line	Corr. (dB)	Margin (dB)	Limit (dBµV)
0.190000	39.4	Off	N	19.4	14.6	54.0
0.246000	24.4	Off	N	19.4	27.5	51.9
0.310000	21.4	Off	N	19.4	28.6	50.0
0.374000	20.2	Off	N	19.4	28.2	48.4
0.518000	19.8	Off	N	19.4	26.2	46.0
4.398000	24.6	Off	N	19.7	21.4	46.0

3.2. Test of Radiated Emission Measurement

3.2.1. Limit of Radiated Emission

The emissions from an unintentional radiator shall not exceed the field strength levels specified in the following table:

Frequency (MHz)	Field Strength (microvolts/meter)	Measurement Distance (meters)
30 – 88	100	3
88 – 216	150	3
216 - 960	200	3
Above 960	500	3

3.2.2. Measuring Instruments

See list of measuring instruments of this test report.

3.2.3. Test Procedures

1. The EUT was placed on a turntable with 0.8 meter above ground.
2. The EUT was set 3 meters from the interference receiving antenna, which was mounted on the top of a variable height antenna tower.
3. The table was rotated 360 degrees to determine the position of the highest radiation.
4. The antenna is a Bi-Log antenna and its height is adjusted between one to four meters above ground to find the maximum value of the field strength for both horizontal polarization and vertical polarization of the antenna.
5. For each suspected emission, the EUT was arranged to its worst case and then tune the antenna tower (from 1 m to 4 m) and turntable (from 0 degree to 360 degrees) to find the maximum reading.
6. Set the test-receiver system to Peak Detect Function and specified bandwidth with Maximum Hold Mode.
7. If the emission level of the EUT in peak mode was 3 dB lower than the limit specified, peak values of EUT will be reported. Otherwise, the emission will be repeated by using the quasi-peak method and reported.
8. Emission level (dBuV/m) = 20 log Emission level (uV/m)
9. Corrected Reading: Antenna Factor + Cable Loss + Read Level - Preamp Factor = Level

3.2.4. Test Setup of Radiated Emission

For radiated emissions from 30MHz to 1GHz

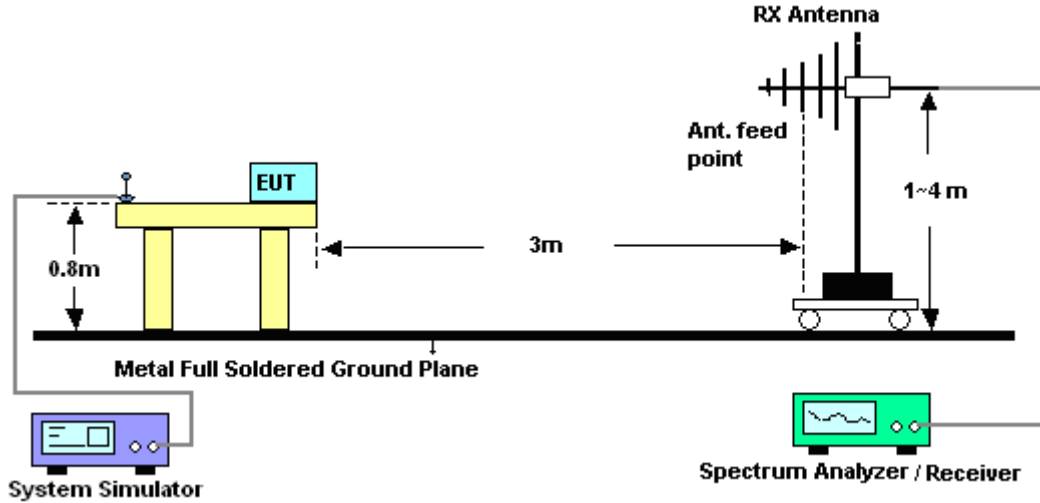

For radiated emissions above 1GHz

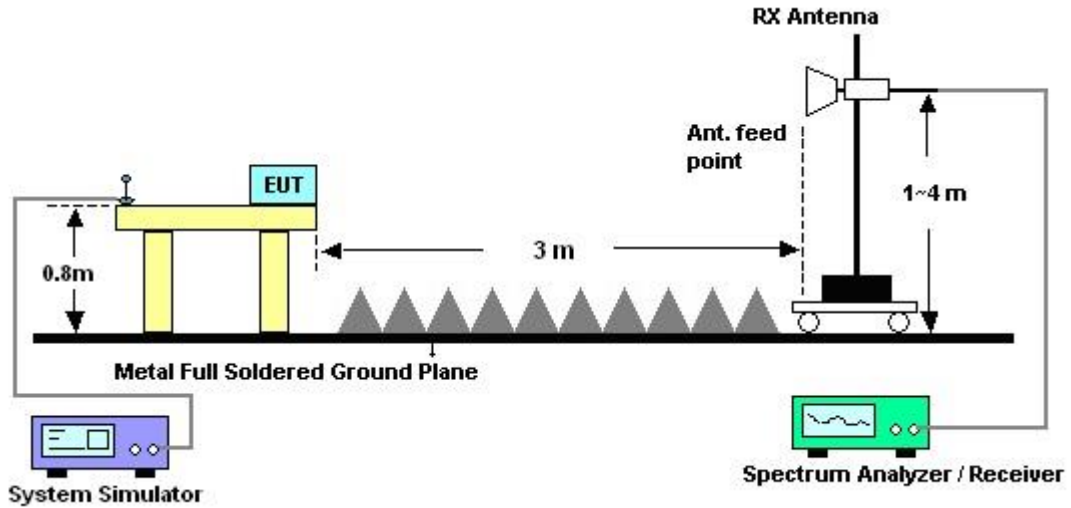



3.2.5. Test Result of Radiated Emission

Test Mode :	Mode 2	Temperature :	22~23°C
Test Engineer :	Timberland Lin	Relative Humidity :	43~44%
Test Distance :	3m	Polarization :	Horizontal
Function Type :	WCDMA Band II Idle + WLAN Idle + USB Cable (Charging from Adapter)		
Remark :	#7 is system simulator signal which can be ignored.		

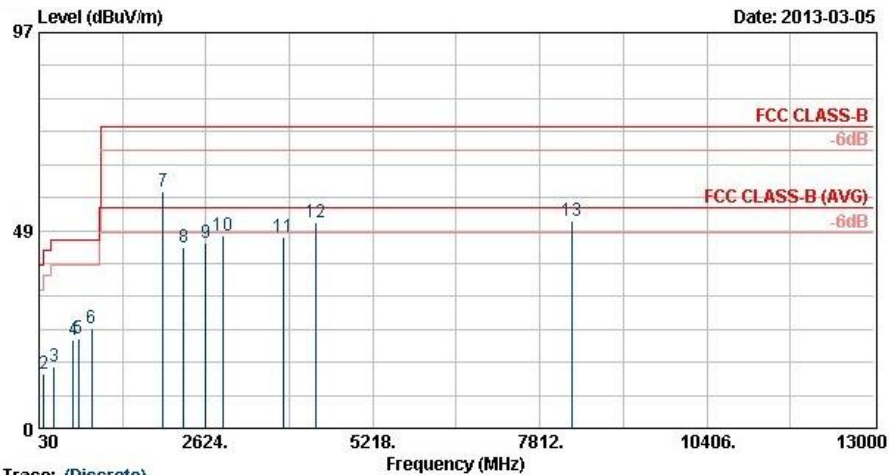

Trace: (Discrete)
 Site : 03CH06-HY
 Condition : FCC CLASS-B HF-ANT_120801 HORIZONTAL
 Power : 120Vac/60Hz
 Mode : Mode 2

	Freq	Level	Over	Limit	Read	Antenna	Preamp	Cable	Ant	Table	Remark
	MHz	dBuV/m	Limit	Line	Level	Factor	Factor	Loss	Pos	Pos	
			dB	dBuV/m	dBuV	dB/m	dB	dB	cm	deg	
1	37.83	19.88	-20.12	40.00	36.54	14.12	31.50	0.72	100	85	Peak
2	106.68	13.17	-30.33	43.50	31.59	11.82	31.38	1.14	---	---	Peak
3	260.04	15.12	-30.88	46.00	30.76	13.70	31.13	1.79	---	---	Peak
4	567.40	21.50	-24.50	46.00	31.35	18.93	31.40	2.62	---	---	Peak
5	645.80	21.96	-24.04	46.00	31.06	19.20	31.09	2.80	---	---	Peak
6	848.80	24.52	-21.48	46.00	31.75	20.20	30.66	3.23	---	---	Peak
7	1960.00	58.02			74.82	31.40	53.99	5.79	---	---	Peak
8	2276.00	44.30	-29.70	74.00	59.77	32.19	53.94	6.28	---	---	Peak
9	2622.00	45.57	-28.43	74.00	59.97	32.64	53.92	6.88	---	---	Peak
10	2900.00	47.25	-26.75	74.00	60.85	32.98	53.98	7.40	---	---	Peak
11	3820.00	46.92	-27.08	74.00	59.36	33.56	54.62	8.63	---	---	Peak
12	4340.00	50.48	-23.52	74.00	61.16	34.60	54.97	9.68	---	---	Peak
13	8310.00	50.93	-23.07	74.00	59.97	36.16	56.01	10.81	100	72	Peak



Test Mode :	Mode 2	Temperature :	22~23°C
Test Engineer :	Timberland Lin	Relative Humidity :	43~44%
Test Distance :	3m	Polarization :	Vertical
Function Type :	WCDMA Band II Idle + WLAN Idle + USB Cable (Charging from Adapter)		
Remark :	#7 is system simulator signal which can be ignored.		

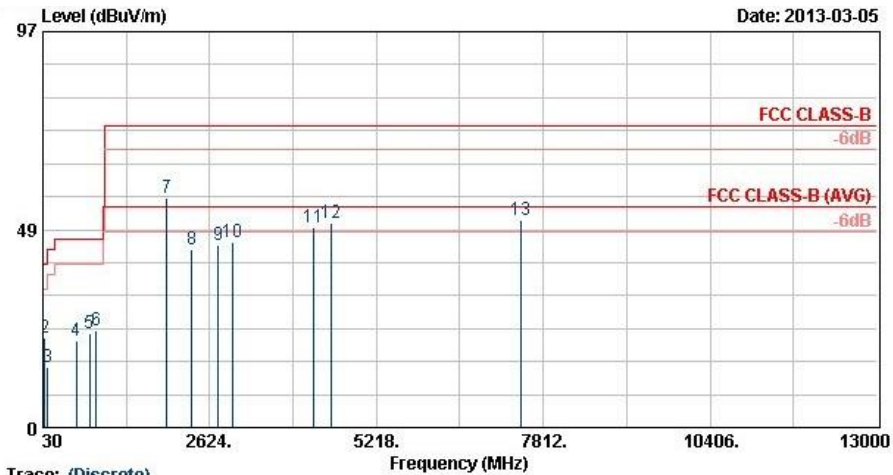

Trace: (Discrete)
 Site : 03CH06-HY
 Condition : FCC CLASS-B HP-ANT_120801 VERTICAL
 Power : 120Vac/60Hz
 Mode : Mode 2

	Freq	Level	Over	Limit	Read	Antenna	Preamp	Cable	Ant	Table	Remark
	MHz	dBuV/m	dB	dBuV/m	dBuV	dB/m	dB	dB	cm	deg	
1 @	30.81	32.88	-7.12	40.00	45.55	18.22	31.54	0.65	100	148	Peak
2	57.54	22.15	-17.85	40.00	46.48	6.32	31.50	0.85	---	---	Peak
3	99.93	14.89	-28.61	43.50	34.53	11.00	31.74	1.10	---	---	Peak
4	554.80	21.34	-24.66	46.00	30.87	19.05	31.15	2.56	---	---	Peak
5	754.30	23.21	-22.79	46.00	31.32	19.75	30.91	3.05	---	---	Peak
6	862.80	23.67	-22.33	46.00	30.89	20.37	30.86	3.27	---	---	Peak
7	1960.00	56.16	72.96	31.40	53.99	5.79	---	---	Peak
8	2350.00	43.77	-30.23	74.00	59.04	32.28	53.93	6.38	---	---	Peak
9	2758.00	44.85	-29.15	74.00	58.89	32.80	53.95	7.11	---	---	Peak
10	2974.00	45.53	-28.47	74.00	58.92	33.06	53.99	7.54	---	---	Peak
11	4236.00	49.16	-24.84	74.00	60.28	34.36	54.95	9.47	---	---	Peak
12	4508.00	50.24	-23.76	74.00	60.18	35.00	55.00	10.06	---	---	Peak
13	7470.00	50.91	-23.09	74.00	59.85	36.10	55.93	10.89	100	115	Peak



4. List of Measuring Equipment

Instrument	Manufacturer	Model No.	Serial No.	Characteristics	Calibration Date	Test Date	Due Date	Remark
EMI Test Receiver	Rohde & Schwarz	ESCS 30	100356	9KHz – 2.75GHz	Nov. 13, 2012	Mar. 05, 2013 ~ Mar. 06, 2013	Nov. 12, 2013	Conduction (CO05-HY)
Two-LISN	Rohde & Schwarz	ENV216	100081	9KHz ~ 30MHz	Dec. 12, 2012	Mar. 05, 2013 ~ Mar. 06, 2013	Dec. 11, 2013	Conduction (CO05-HY)
Two-LISN	Rohde & Schwarz	ENV216	100080	9KHz ~ 30MHz	Dec. 06, 2012	Mar. 05, 2013 ~ Mar. 06, 2013	Dec. 05, 2013	Conduction (CO05-HY)
AC Power Source	APC	APC-1000W	N/A	N/A	N/A	Mar. 05, 2013 ~ Mar. 06, 2013	N/A	Conduction (CO05-HY)
Spectrum Analyzer	R&S	FSP30	101352	9KHz~30GHz	Nov. 07, 2012	Mar. 05, 2013	Nov. 06, 2013	Radiation (03CH06-HY)
Spectrum Analyzer	Agilent	E4408B	MY44211030	9KHz ~ 26.5GHz	Nov. 26, 2012	Mar. 05, 2013	Nov. 25, 2013	Radiation (03CH06-HY)
EMI Test Receiver	R&S	ESVS10	834468/0003	20MHz ~ 1000MHz	May 04, 2012	Mar. 05, 2013	May 03, 2013	Radiation (03CH06-HY)
Bilog Antenna	SCHAFFNER	CBL6112B	2885	30MHz ~ 2GHz	Oct. 06, 2012	Mar. 05, 2013	Oct. 05, 2013	Radiation (03CH06-HY)
Double Ridge Horn Antenna	EMCO	3117	00066583	1GHz ~ 18GHz	Aug. 01, 2012	Mar. 05, 2013	Jul. 31, 2013	Radiation (03CH06-HY)
Double Ridge Horn Antenna	COM-POWER	AH-118	071025	1GHz~18GHz	Aug. 09, 2012	Mar. 05, 2013	Aug. 08, 2013	Radiation (03CH06-HY)
SHF-EHF Horn Antenna	SCHWARZBECK	BBHA 9170	BBHA9170251	15GHz ~ 40GHz	Sep. 28, 2012	Mar. 05, 2013	Sep. 27, 2013	Radiation (03CH06-HY)
Preamplifier	Agilent	8449B	3008A01917	1GHz ~ 26.5GHz	Apr. 13, 2012	Mar. 05, 2013	Apr. 12, 2013	Radiation (03CH06-HY)
Amplifier	Agilent	310N	186713	9KHz ~ 1GHz	Apr. 11, 2012	Mar. 05, 2013	Apr. 10, 2013	Radiation (03CH06-HY)
Pre Amplifier	EMCI	EMC051845	SN980048	1GHz ~ 18GHz	Jul. 21, 2012	Mar. 05, 2013	Jul. 20, 2013	Radiation (03CH06-HY)
Preamplifier	MITEQ	AMF-7D-0010 1800-30-10P	159087	1GHz~18GHz	Feb. 26, 2013	Mar. 05, 2013	Feb. 25, 2014	Radiation (03CH06-HY)
System Simulator	R&S	CMU200	117995	N/A	Jul. 28, 2011	Mar. 05, 2013 ~ Mar. 06, 2013	Jul. 27, 2013	-
LTE Base Station	Anritsu	MT8820C	6201074414	N/A	Dec. 11, 2012	Mar. 05, 2013 ~ Mar. 06, 2013	Dec. 10, 2014	-

5. Uncertainty of Evaluation

Uncertainty of Conducted Emission Measurement (150 KHz ~ 30 MHz)

Measuring Uncertainty for a Level of Confidence of 95% ($U = 2Uc(y)$)	2.26
---	------

Uncertainty of Radiated Emission Measurement (30 MHz ~ 1000 MHz)

Measuring Uncertainty for a Level of Confidence of 95% ($U = 2Uc(y)$)	2.54
---	------

Uncertainty of Radiated Emission Measurement (1 GHz ~ 40 GHz)

Measuring Uncertainty for a Level of Confidence of 95% ($U = 2Uc(y)$)	4.72
---	------



Appendix A. Photographs of EUT

Please refer to Sporton report number EP330402 as below.