



# Antenna Part Specification

Customer name:	Cosonic Intelligent Technologies Co., Ltd.
Project name:	CE-2205N(T40)
Material category:	L-FPC
Antenna type:	monopole
Version:	V2.0
Date:	2024.10.21
Manufacturer:	Shenzhen Cicent Communication Technology Co., Ltd.
Manufacturer Address:	505-506 ,ABlock,Donglian Building,Chuangye 2 road,Baoan District,Shenzhen,Guangdong,P.R china



# Contents

I: The report of passive data ..... 2  
II: Matching circuit ..... 5  
III: Structure file ..... 6

Change record			
Compile / change date	Reason for change	Changed content	Version
2024.04.25	First edition	First edition	V1.0
2024.10.21	Antenna optimization	Antenna optimization	V2.0



I: The report of passive data



Angilent E5071C

S11 parameter:

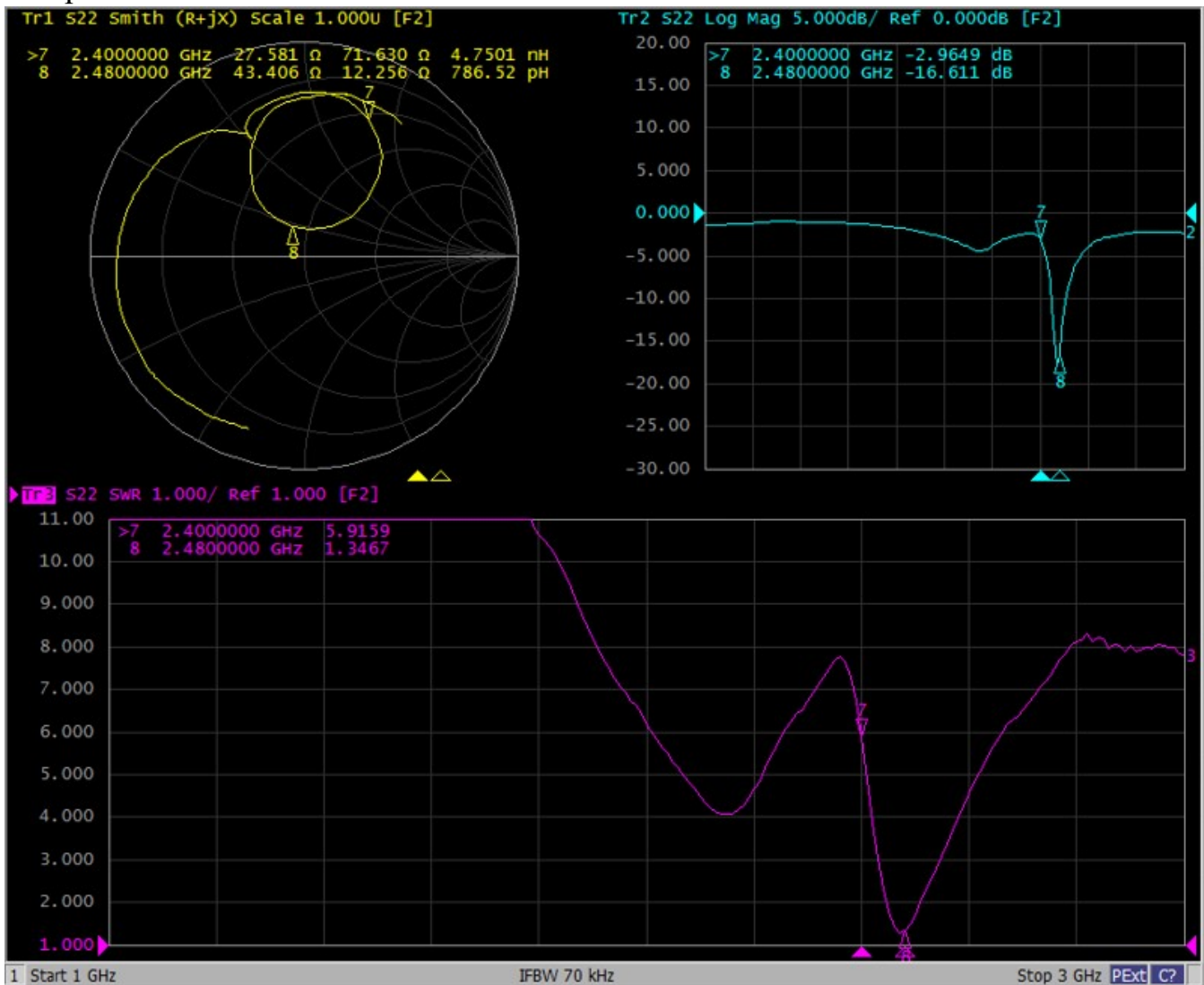



Efficiency:

L			
Frequency (MHz)	Efficiency	Efficiency (dB )	Gain (dBi)
2400	7.6	-11.2	-8.1
2410	9.5	-10.2	-7.2
2420	11.2	-9.5	-6.8
2430	12.7	-9.0	-6.3
2440	15.3	-8.2	-5.3
2450	17.3	-7.6	-4.5
2460	20.5	-6.9	-3.4
2470	23.5	-6.3	-2.5
2480	23.9	-6.2	-2.3
Average value	15.7	-8.3	-5.2

2400~2480MHz:

Peak Gain:-2.3dBi Min Gain:-8.1dBi Avg Gain:-5.2dBi

3D Antenna radiation pattern:

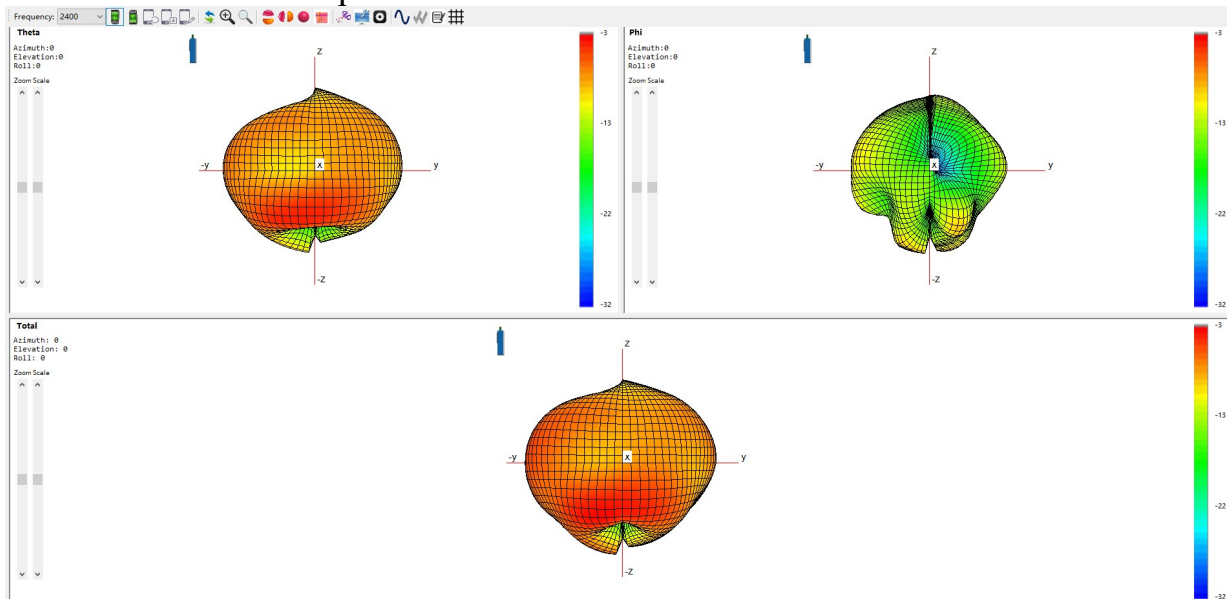



## Antenna radiation pattern:

### Theta=90.00deg

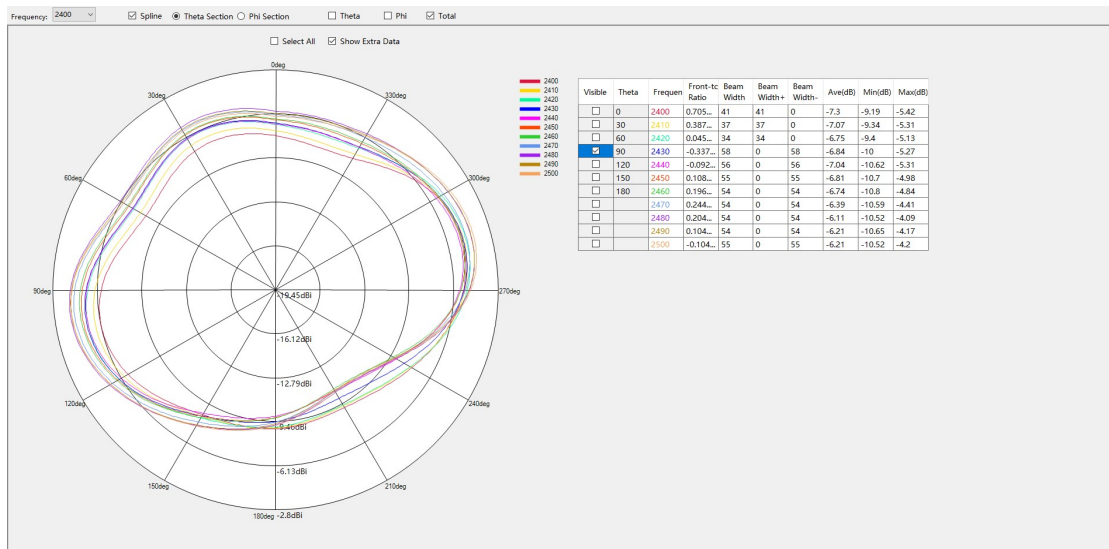

### Phi=90.00deg

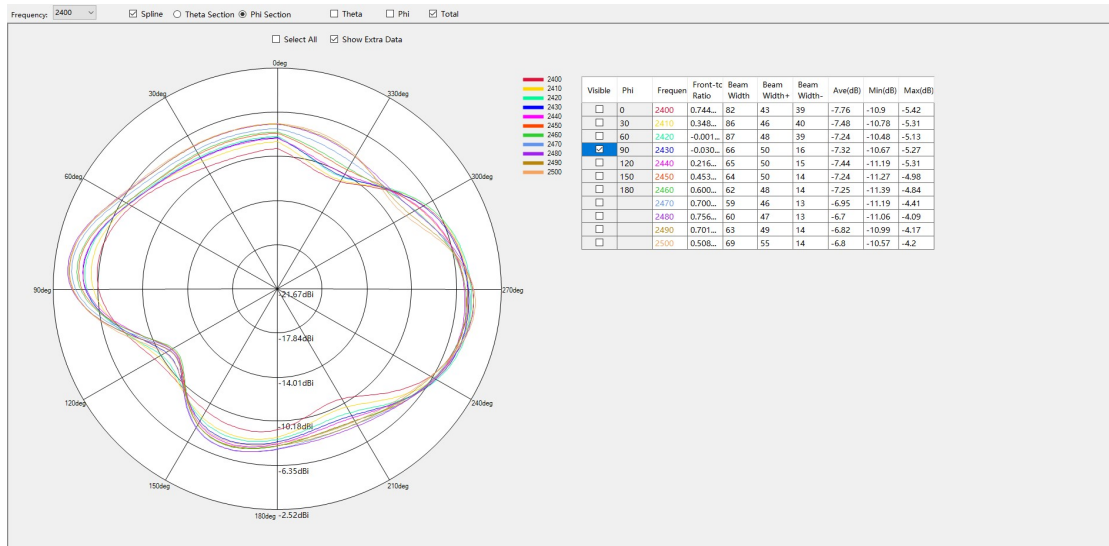

### Phi=0.00deg

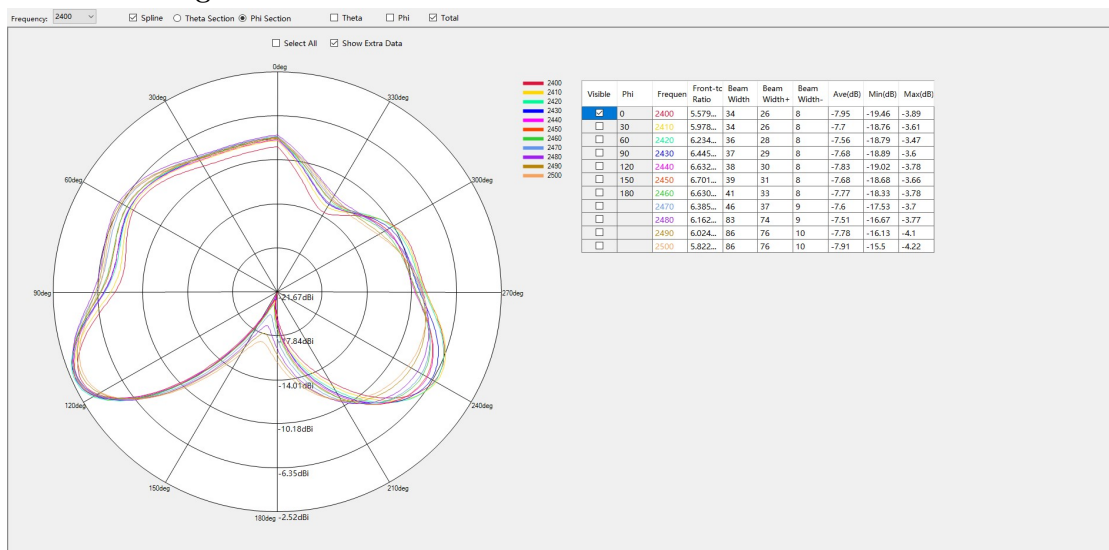



II: Matching circuit

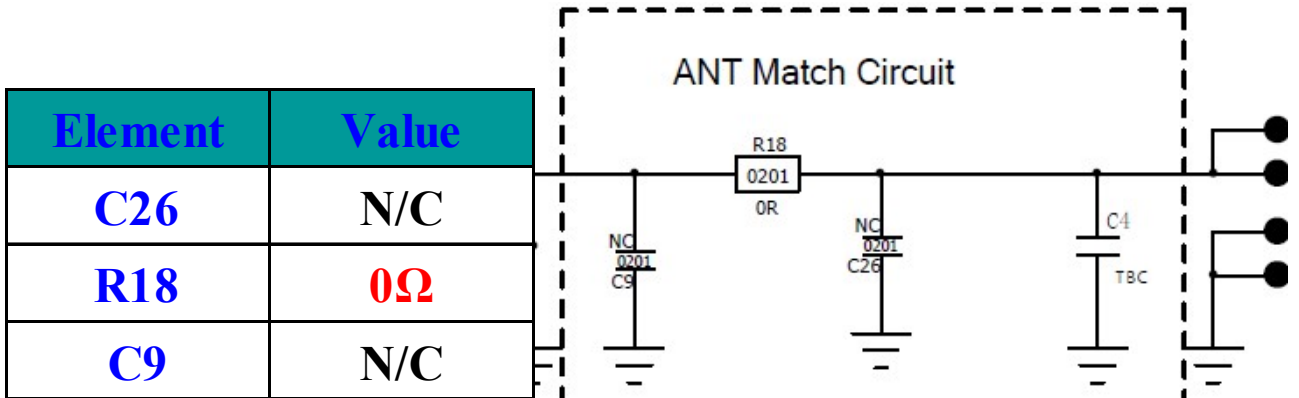



III: Structure file

