



FCC TEST REPORT (PART 27)

REPORT NO.: RF110425E01A
MODEL NO.: 9361 Home Cell V2.0 1700MHz 100mW
FCC ID: ZMYV2ACAWS100
RECEIVED: Apr. 25, 2011
TESTED: Apr. 29 ~ May 12, 2011
ISSUED: May 13, 2011

APPLICANT: MitraStar Technology Corporation

ADDRESS: No. 6, Innovation Road II, Hsinchu Science Park, Hsinchu 300, Taiwan (R.O.C.)

ISSUED BY: Bureau Veritas Consumer Products Services (H.K.) Ltd., Taoyuan Branch

LAB ADDRESS: No. 47, 14th Ling, Chia Pau Tsuen, Lin Kou Hsiang, Taipei Hsien 244, Taiwan, R.O.C.

TEST LOCATION: No. 19, Hwa Ya 2nd Rd, Wen Hwa Tsuen, Kwei Shan Hsiang, Taoyuan Hsien 333, Taiwan, R.O.C.

This test report consists of 44 pages in total. It may be duplicated completely for legal use with the approval of the applicant. It should not be reproduced except in full, without the written approval of our laboratory. The client should not use it to claim product, certification, approval or endorsement by TAF or any government agency. The test results in the report only apply to the tested sample.





A D T

TABLE OF CONTENTS

RELEASE CONTROL RECORD.....	4
1 CERTIFICATION	5
2 SUMMARY OF TEST RESULTS	6
2.1 MEASUREMENT UNCERTAINTY	6
3 GENERAL INFORMATION.....	7
3.1 GENERAL DESCRIPTION OF EUT	7
3.2 DESCRIPTION OF TEST MODES.....	8
3.2.1 CONFIGURATION OF SYSTEM UNDER TEST	8
3.2.2 TEST MODE APPLICABILITY AND TESTED CHANNEL DETAIL	9
3.3 GENERAL DESCRIPTION OF APPLIED STANDARDS	12
3.4 DESCRIPTION OF SUPPORT UNITS	12
4 TEST TYPES AND RESULTS	13
4.1 OUTPUT POWER MEASUREMENT	13
4.1.1 LIMITS OF OUTPUT POWER MEASUREMENT	13
4.1.2 TEST INSTRUMENTS	14
4.1.3 TEST PROCEDURES	15
4.1.4 TEST SETUP	15
4.1.5 EUT OPERATING CONDITIONS	15
4.1.6 TEST RESULTS	16
4.2 FREQUENCY STABILITY MEASUREMENT	17
4.2.1 LIMITS OF FREQUENCY STABILITY MEASUREMENT	17
4.2.2 TEST INSTRUMENTS	17
4.2.3 TEST PROCEDURE	18
4.2.4 TEST SETUP	18
4.2.5 TEST RESULTS	19
4.3 OCCUPIED BANDWIDTH MEASUREMENT	20
4.3.1 LIMITS OF OCCUPIED BANDWIDTH MEASUREMENT	20
4.3.2 TEST INSTRUMENTS	20
4.3.3 TEST SETUP	20
4.3.4 TEST PROCEDURES	21
4.3.5 TEST RESULTS	22
4.4 PEAK TO AVERAGE RATIO	23
4.4.1 LIMITS OF PEAK TO AVERAGE RATIO MEASUREMENT	23
4.4.2 TEST INSTRUMENTS	23
4.4.3 TEST SETUP	23
4.4.4 TEST PROCEDURES	24
4.4.5 EUT OPERATING CONDITION	24
4.4.6 TEST RESULTS	25
4.5 BAND EDGE MEASUREMENT	26



A D T

4.5.1	LIMITS OF BAND EDGE MEASUREMENT	26
4.5.2	TEST INSTRUMENTS	26
4.5.3	TEST SETUP	26
4.5.4	TEST PROCEDURES	27
4.5.5	EUT OPERATING CONDITION	27
4.5.6	TEST RESULTS	28
4.6	CONDUCTED SPURIOUS EMISSIONS	29
4.6.1	LIMITS OF CONDUCTED SPURIOUS EMISSIONS MEASUREMENT	29
4.6.2	TEST INSTRUMENTS	29
4.6.3	TEST PROCEDURE	30
4.6.4	TEST SETUP	30
4.6.5	EUT OPERATING CONDITIONS	30
4.6.6	TEST RESULTS	31
4.7	RADIATED EMISSION MEASUREMENT	36
4.7.1	LIMITS OF RADIATED EMISSION MEASUREMENT	36
4.7.2	TEST INSTRUMENTS	37
4.7.3	TEST PROCEDURES	38
4.7.4	DEVIATION FROM TEST STANDARD	38
4.7.5	TEST SETUP	39
4.7.6	EUT OPERATING CONDITIONS	39
4.7.7	TEST RESULTS (BELOW 1GHz)	40
4.7.8	TEST RESULTS (ABOVE 1GHz)	41
5	INFORMATION ON THE TESTING LABORATORIES	43
6	APPENDIX A – MODIFICATIONS RECORDERS FOR ENGINEERING CHANGES TO THE EUT BY THE LAB.....	44



A D T

RELEASE CONTROL RECORD

ISSUE NO.	REASON FOR CHANGE	DATE ISSUED
Original release	N/A	May 13, 2011



1 CERTIFICATION

PRODUCT : 3G Femtocell

BRAND : Alcatel-Lucent

MODEL : 9361 Home Cell V2.0 1700MHz 100mW

APPLICANT : MitraStar Technology Corporation

TESTED : Apr. 29 ~ May 12, 2011

TEST SAMPLE : ENGINEERING SAMPLE

TEST STANDARDS : FCC Part 27, Subpart C, L

FCC Part 2

ANSI C63.4-2003

The above equipment (model: 9361 Home Cell V2.0 1700MHz 100mW) has been tested by **Bureau Veritas Consumer Products Services (H.K.) Ltd., Taoyuan Branch**, and found compliance with the requirement of the above standards. The test record, data evaluation & Equipment Under Test (EUT) configurations represented herein are true and accurate accounts of the measurements of the sample's EMC characteristics under the conditions specified in this report.

PREPARED BY :  , DATE: May 13, 2011
Pettie Chen / Specialist

APPROVED BY :  , DATE: May 13, 2011
Gary Chang / Assistant Manager

2 SUMMARY OF TEST RESULTS

The EUT has been tested according to the following specifications:

OPERATING BAND: 2112.4 ~ 2152.6 MHz			
STANDARD SECTION	TEST TYPE AND LIMIT	RESULT	REMARK
2.1046 27.50(d)(4)	Maximum Peak Output Power Limit: max. 1 watts e.i.r.p peak power	PASS	Meet the requirement of limit. Minimum passing margin is 21.3dBm at 2132.4MHz.
2.1055 27.54	Frequency Stability	PASS	Meet the requirement of limit.
2.1049 27.53(h)	Occupied Bandwidth	PASS	Meet the requirement of limit.
27.50(d)(5)	Peak to average ratio	PASS	Meet the requirement of limit.
27.53(h)	Band Edge Measurements	PASS	Meet the requirement of limit.
2.1051 27.53(h)	Conducted Spurious Emissions	PASS	Meet the requirement of limit.
2.1053 27.53(h)	Radiated Spurious Emissions	PASS	Meet the requirement of limit. Minimum passing margin is -15.8dB at 6337.2MHz.

2.1 MEASUREMENT UNCERTAINTY

Where relevant, the following measurement uncertainty levels have been estimated for tests performed on the EUT as specified in CISPR 16-4-2:

MEASUREMENT	FREQUENCY	UNCERTAINTY
Conducted emissions	9kHz~30MHz	2.44 dB
Radiated emissions	30MHz ~ 200MHz	2.93 dB
	200MHz ~1000MHz	2.95 dB
	1GHz ~ 18GHz	2.26 dB
	18GHz ~ 40GHz	1.94 dB

This uncertainty represents an expanded uncertainty expressed at approximately the 95% confidence level using a coverage factor of k=2.

3 GENERAL INFORMATION

3.1 GENERAL DESCRIPTION OF EUT

PRODUCT	3G Femtocell
MODEL NO.	9361 Home Cell V2.0 1700MHz 100mW
FCC ID	ZMYV2ACAWS100
POWER SUPPLY	12Vdc (adapter)
OPERATION TEMPERATURE RANGE	-20°C ~ 55°C
MODULATION TECHNOLOGY	BPSK
FREQUENCY RANGE	2112.4MHz ~2152.6MHz
MAX. EIRP POWER (W)	0.135W
RELEASE VERSION	Release 5 / 6
ANTENNA TYPE	Fixed Internal antenna with 3.5dBi gain
DATA CABLE	NA
I/O PORTS	Refer to user's manual
ACCESSORY DEVICES	Adapter

NOTE:

1. The EUT were powered by the following adapter:

BRAND:	DVE
MODEL:	DSA-12G-12 FUS 120120
INPUT:	100-240Vac, 50/60Hz, 0.3A
OUTPUT:	12Vdc, 1A
POWER LINE:	2.0m non-shielded cable without core

2. The above EUT information is declared by manufacturer and for more detailed features description, please refer to the manufacturer's specifications or User's Manual.

3.2 DESCRIPTION OF TEST MODES

Three channels had been tested.

	Channel	Frequency(MHz)
Low channel (L)	1537	2112.4
Middle channel (M)	1637	2132.4
High channel (H)	1738	2152.6

3.2.1 CONFIGURATION OF SYSTEM UNDER TEST

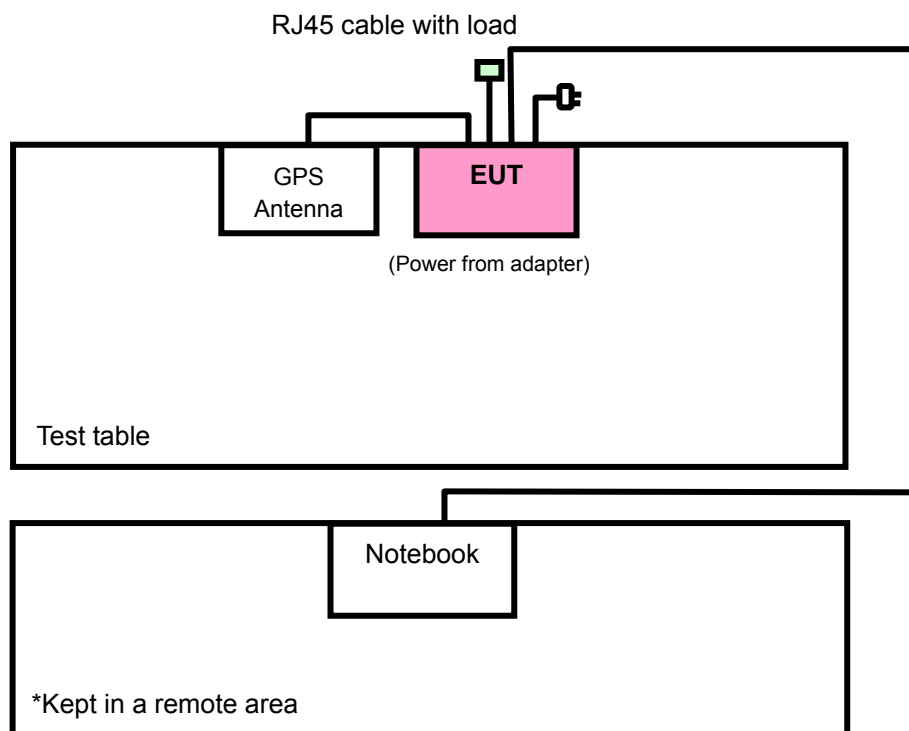

3.2.2 TEST MODE APPLICABILITY AND TESTED CHANNEL DETAIL

EUT CONFIGURE MODE	APPLICABLE TO								DESCRIPTION
	OP	FS	OB	PA	BE	CE	RE<1G	RE≥1G	
-	V	V	V	V	V	V	V	V	-

Where **OP**: Output power **FS**: Frequency stability
OB: Occupied bandwidth **PA**: Peak to Average Ratio
BE: Band edge **CE**: Conducted spurious emissions
RE<1G: Radiated emission below 1GHz **RE≥1G**: Radiated emission above 1GHz

OUTPUT POWER MEASUREMENT:

- Pre-Scan has been conducted to determine the worst-case mode from all possible combinations between available modulations, XYZ axis and antenna ports (if EUT with antenna diversity architecture).
- Following channel(s) was (were) selected for the final test as listed below.

EUT CONFIGURE MODE	AVAILABLE CHANNEL	TESTED CHANNEL	MODULATION TECHNOLOGY	AXIS
-	1537 to 1738	1537, 1637, 1738	BPSK	Z

FREQUENCY STABILITY MEASUREMENT:

- Pre-Scan has been conducted to determine the worst-case mode from all possible combinations between available modulations and antenna ports (if EUT with antenna diversity architecture).
- Following channel(s) was (were) selected for the final test as listed below.

EUT CONFIGURE MODE	AVAILABLE CHANNEL	TESTED CHANNEL	MODULATION TECHNOLOGY
-	1537 to 1738	1738	BPSK

OCCUPIED BANDWIDTH MEASUREMENT:

- This item includes all test value of each mode, but only includes spectrum plot of worst value of each mode.
- Pre-Scan has been conducted to determine the worst-case mode from all possible combinations between available modulations and antenna ports (if EUT with antenna diversity architecture).
- Following channel(s) was (were) selected for the final test as listed below.

EUT CONFIGURE MODE	AVAILABLE CHANNEL	TESTED CHANNEL	MODULATION TECHNOLOGY
-	1537 to 1738	1537, 1637, 1738	BPSK

PEAK TO AVERAGE RATIO:

- This item includes all test value of each mode, but only includes spectrum plot of worst value of each mode.
- Pre-Scan has been conducted to determine the worst-case mode from all possible combinations between available modulations, XYZ axis and antenna ports (if EUT with antenna diversity architecture).
- Following channel(s) was (were) selected for the final test as listed below.

EUT CONFIGURE MODE	AVAILABLE CHANNEL	TESTED CHANNEL	MODULATION TECHNOLOGY
-	1537 to 1738	1537, 1637, 1738	BPSK

BAND EDGE MEASUREMENT:

- Pre-Scan has been conducted to determine the worst-case mode from all possible combinations between available modulations, XYZ axis and antenna ports (if EUT with antenna diversity architecture).
- Following channel(s) was (were) selected for the final test as listed below.

EUT CONFIGURE MODE	AVAILABLE CHANNEL	TESTED CHANNEL	MODULATION TECHNOLOGY
-	1537 to 1738	1537, 1738	BPSK

CONDUCTED SPURIOUS EMISSIONS MEASUREMENT:

- Pre-Scan has been conducted to determine the worst-case mode from all possible combinations between available modulations and antenna ports (if EUT with antenna diversity architecture).
- Following channel(s) was (were) selected for the final test as listed below.

EUT CONFIGURE MODE	AVAILABLE CHANNEL	TESTED CHANNEL	MODULATION TECHNOLOGY
-	1537 to 1738	1537, 1637, 1738	BPSK

RADIATED EMISSION MEASUREMENT (BELOW 1 GHz):

- Pre-Scan has been conducted to determine the worst-case mode from all possible combinations between available modulations, XYZ axis and antenna ports (if EUT with antenna diversity architecture).
- Following channel(s) was (were) selected for the final test as listed below.

EUT CONFIGURE MODE	AVAILABLE CHANNEL	TESTED CHANNEL	MODULATION TECHNOLOGY	AXIS
-	1537 to 1738	1738	BPSK	Z

RADIATED EMISSION MEASUREMENT (ABOVE 1 GHz):

- Pre-Scan has been conducted to determine the worst-case mode from all possible combinations between available modulations, XYZ axis and antenna ports (if EUT with antenna diversity architecture).
- Following channel(s) was (were) selected for the final test as listed below.

EUT CONFIGURE MODE	AVAILABLE CHANNEL	TESTED CHANNEL	MODULATION TECHNOLOGY	AXIS
-	1537 to 1738	1537, 1637, 1738	BPSK	Z

TEST CONDITION:

APPLICABLE TO	ENVIRONMENTAL CONDITIONS	INPUT POWER (SYSTEM)	TESTED BY
OP	23deg. C, 62%RH, 1012 hPa	120Vac, 60Hz	Long Chen
FS	23deg. C, 62%RH, 1012 hPa	120Vac, 60Hz	Long Chen
OB	23deg. C, 62%RH, 1012 hPa	120Vac, 60Hz	Long Chen
PA	23deg. C, 62%RH, 1012 hPa	120Vac, 60Hz	Long Chen
BE	23deg. C, 62%RH, 1012 hPa	120Vac, 60Hz	Long Chen
CE	25deg. C, 65%RH, 1008 hPa	120Vac, 60Hz	David Huang
RE < 1G	25deg. C, 68%RH, 1010 hPa	120Vac, 60Hz	Sun Lin
RE ≥ 1G	25deg. C, 68%RH, 1010 hPa	120Vac, 60Hz	Sun Lin

3.3 GENERAL DESCRIPTION OF APPLIED STANDARDS

The EUT is a RF product. According to the specifications of the manufacturer, it must comply with the requirements of the following standards:

FCC 47 CFR Part 2

FCC 47 CFR Part 27

ANSI C63.4-2003

ANSI/TIA/EIA-603-C 2004

All test items have been performed and recorded as per the above standards.

NOTE: The EUT is also considered as a kind of computer peripheral, because the connection to computer is necessary for typical use. It has been verified to comply with the requirements of FCC Part 15, Subpart B, Class B (DoC). The test report has been issued separately.

3.4 DESCRIPTION OF SUPPORT UNITS

The EUT has been tested as an independent unit together with other necessary accessories or support units. The following support units or accessories were used to form a representative test configuration during the tests.

NO.	PRODUCT	BRAND	MODEL NO.	SERIAL NO.	FCC ID
1	NOTEBOOK	DELL	D531	CN-0XM006-48643 -81U-2973	QDS-BRCM1020

NO.	SIGNAL CABLE DESCRIPTION OF THE ABOVE SUPPORT UNITS
1	10m RJ45 cable without core

NOTE:

1. All power cords of the above support units are non shielded (1.8m).
2. Item 1 acted as a communication partner to transfer data.

4 TEST TYPES AND RESULTS

4.1 OUTPUT POWER MEASUREMENT

4.1.1 LIMITS OF OUTPUT POWER MEASUREMENT

Maximum output power is 1W EIRP.

4.1.2 TEST INSTRUMENTS

DESCRIPTION & MANUFACTURER	MODEL NO.	SERIAL NO.	DATE OF CALIBRATION	DUE DATE OF CALIBRATION
Test Receiver ROHDE & SCHWARZ	ESCI	100424	Aug. 04, 2010	Aug. 03, 2011
Spectrum Analyzer ROHDE & SCHWARZ	FSP40	100041	Jul. 09, 2010	Jul. 08, 2011
BILOG Antenna SCHWARZBECK	VULB9168	9168-156	Apr. 12, 2011	Apr. 11, 2012
HORN Antenna SCHWARZBECK	BBHA 9120 D	9120D-209	Aug. 02, 2010	Aug. 01, 2011
HORN Antenna SCHWARZBECK	BBHA 9170	BBHA9170243	Dec. 27, 2010	Dec. 26, 2011
Preamplifier Agilent	8449B	3008A01910	Sep. 09, 2010	Sep. 08, 2011
Preamplifier Agilent	8447D	2944A10638	Nov. 03, 2010	Nov. 02, 2011
RF signal cable HUBER+SUHNNER	SUCOFLEX 104	218190/4 231241/4	May 14, 2010	May 13, 2011
RF signal cable Worken	8D-FB	Cable-HYCH9-01	Aug. 20, 2010	Aug. 19, 2011
Software	ADT_Radiated_ V7.6.15.9.2	NA	NA	NA
Antenna Tower EMCO	2070/2080	512.835.4684	NA	NA
Turn Table EMCO	2087-2.03	NA	NA	NA
Antenna Tower & Turn Table Controller EMCO	2090	NA	NA	NA

- NOTE:**
1. The calibration interval of the above test instruments is 12 months and the calibrations are traceable to NML/ROC and NIST/USA.
 2. The test was performed in HwaYa Chamber 9.
 3. The horn antenna and HP preamplifier (model: 8449B) are used only for the measurement of emission frequency above 1GHz if tested.
 4. The FCC Site Registration No. is 460141.
 5. The IC Site Registration No. is IC 7450F-4.

4.1.3 TEST PROCEDURES

- a. The EUT was set up for the maximum power with WCDMA link data modulation. The power was measured with R&S Spectrum Analyzer. All measurements were done at 3 channels (low, middle and high operational frequency range). RWB and VBW is 5MHz.
- b. E.I.R.P power measurement. In the semi-anechoic chamber, EUT placed on the 0.8m height of Turn Table, rotated the table around 360 degrees to search the maximum radiation power and receiver antenna shall be rotated vertical and horizontal polarization and moved height from 1m to 4m to find the maximum polar radiated power. The “Read Value” is the spectrum reading the maximum power value.
- c. The substitution horn antenna is substituted for EUT at the same position and signals generator export the CW signal to the substitution antenna via a TX cable. Rotated the Turn Table and moved receiving antenna to find the maximum radiation power. Adjust output power level of S.G to get a Value of spectrum reading equal to “Read Value” of step a. Record the power level of S.G
- d. $EIRP = \text{Output power level of S.G} - \text{TX cable loss} + \text{Antenna gain of substitution horn}$
- e. $E.R.P = E.I.R.P - 2.15 \text{ dB}$

4.1.4 TEST SETUP

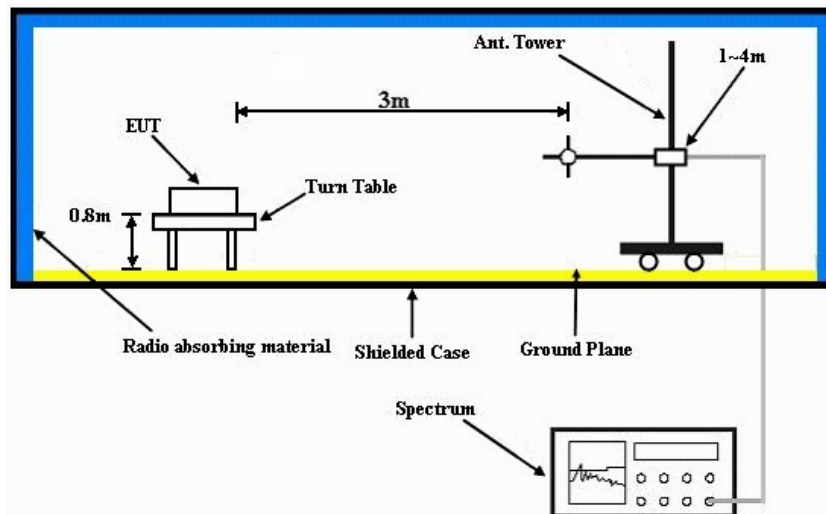

For the actual test configuration, please refer to the attached file (Test Setup Photo).

4.1.5 EUT OPERATING CONDITIONS

- a. Placed the EUT on the testing table.
- b. Prepared notebook to act as communication partner and placed it outside of testing area.
- c. Notebook sends commands to control EUT to transmit at specific frequency, modulation and output power level via telnet utility.

4.1.6 TEST RESULTS

EIRP POWER					
CHANNEL NO.	FREQUENCY (MHz)	CORRECTION FACTOR (dB)	S.G LEVEL (dBm)	OUTPUT POWER	
				dBm	mW
1537	2112.4	8.4	12.6	21.0	125.9
1637	2132.4	8.4	12.9	21.3	134.9
1738	2152.6	8.4	12.3	20.7	117.5

REMARKS: 1. Output Power (dBm) = Raw Value (dBm) + Correction Factor (dB).
 2. Correction Factor (dB) = S.G Level + Gain of Substitution horn + TX cable loss.
 3. The value in bold is the worst.

4.2 FREQUENCY STABILITY MEASUREMENT

4.2.1 LIMITS OF FREQUENCY STABILITY MEASUREMENT

According to the FCC part 27.54 shall be tested the frequency stability. The rule is defined that” The frequency stability shall be sufficient to ensure that the fundamental emissions stay within the authorized bands of operation. The test extreme voltage is according to the 2.1055(d)(1) Vary primary supply voltage from 85 to 115 percent of the nominal value for other than hand carried battery equipment and the extreme temperature rule is comply with the 2.1055(a)(1) $-30^{\circ}\text{C} \sim 50^{\circ}\text{C}$.

4.2.2 TEST INSTRUMENTS

DESCRIPTION & MANUFACTURER	MODEL NO.	SERIAL NO.	DATE OF CALIBRATION	DUE DATE OF CALIBRATION
* Hewlett Packard RF cable	8120-6192	274388	Oct. 22, 2010	Oct. 21, 2011
* Suhner RF cable	Sucoflex104	246272	May 14, 2010	May 13, 2011
* WIT Standard Temperature & Humidity Chamber	TH-4S-C	W981030	Jun. 28, 2010	Jun. 27, 2011

- NOTE:**
1. The calibration interval of the above test instruments is 12 months. And the calibrations are traceable to NML/ROC and NIST/USA.
 2. “*” = These equipments are used for the final measurement.
 3. The test was performed in ADT RF OVEN room.

4.2.3 TEST PROCEDURE

- a. Because of the measure the carrier frequency under the condition of the AFC lock, it shall be used the mobile station in the WCDMA link mode. This is accomplished with the use of the communication simulator station. The oven room could control the temperatures and humidity.
- b. Power must be removed when changing from one temperature to another or one voltage to another voltage. Power warm up is at least 15 min and power applied should perform before recording frequency error.
- c. Laptop pc is connected the external power supply to control the AC input power. The various Volts from the minimum 126.5 Volts to 93.5 Volts. Each step shall be record the frequency error rate.
- d. The temperature range step is 10 degrees in this test items. All temperature levels shall be hold the $\pm 0.5^{\circ}\text{C}$ during the measurement testing.
- e. The each temperature step shall be at least 0.5 hours, consider the EUT could be test under the stability condition.

NOTE: The frequency error was recorded frequency error from the communication simulator.

4.2.4 TEST SETUP

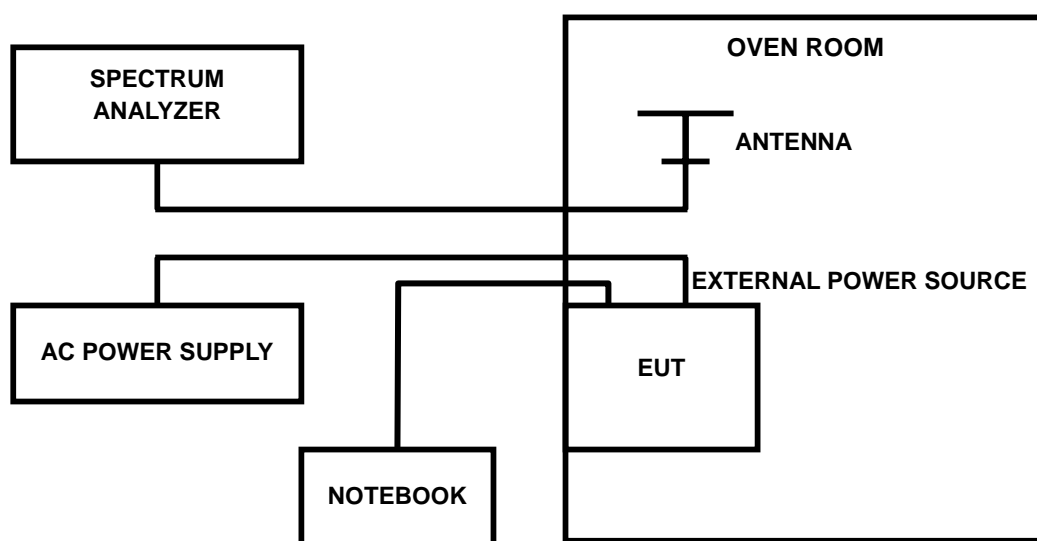

4.2.5 TEST RESULTS

AFC FREQUENCY ERROR vs. VOLTAGE		
FREQUENCY ERROR (ppm)		
VOLTAGE (Volts)	Channel 1738: 2152.6MHz	DEVIATION (ppm)
93.5	2152.601190	0.553
110.0	2152.601172	0.544
126.5	2152.601442	0.670

AFC FREQUENCY ERROR vs. TEMP.		
FREQUENCY ERROR (ppm)		
TEMP. (°C)	Channel 1738: 2152.6MHz	DEVIATION (ppm)
50	2152.601369	0.636
40	2152.601087	0.505
30	2152.600923	0.429
20	2152.601172	0.544
10	2152.600837	0.389
0	2152.601154	0.536
-10	2152.600886	0.412
-20	2152.601342	0.623
-30	2152.601138	0.529

4.3 OCCUPIED BANDWIDTH MEASUREMENT

4.3.1 LIMITS OF OCCUPIED BANDWIDTH MEASUREMENT

The width of a frequency band such that, below the lower and above the upper frequency limits, the mean powers emitted are each equal to a specified percentage 0.5 %of the total mean power of a given emission.

4.3.2 TEST INSTRUMENTS

DESCRIPTION & MANUFACTURER	MODEL NO.	SERIAL NO.	DATE OF CALIBRATION	DUE DATE OF CALIBRATION
* Mini-Circuits Power Splitter	ZAPD-4	NA	Jun. 29, 2010	Jun. 28, 2011
* Hewlett Packard RF cable	8120-6192	274388	Oct. 22, 2010	Oct. 21, 2011
* JFW 20dB attenuation	50HF-020-SMA	NA	NA	NA
* Suhner RF cable	Sucoflex104	246272	May 14, 2010	May 13, 2011
* ROHDE & SCHWARZ Spectrum Analyzer	E4446A	MY44360128	Feb. 22, 2011	Feb. 21, 2012

NOTE: 1. The calibration interval of the above test instruments is 12 months. And the calibrations are traceable to NML/ROC and NIST/USA.

2. "*" = These equipments are used for the final measurement.

4.3.3 TEST SETUP

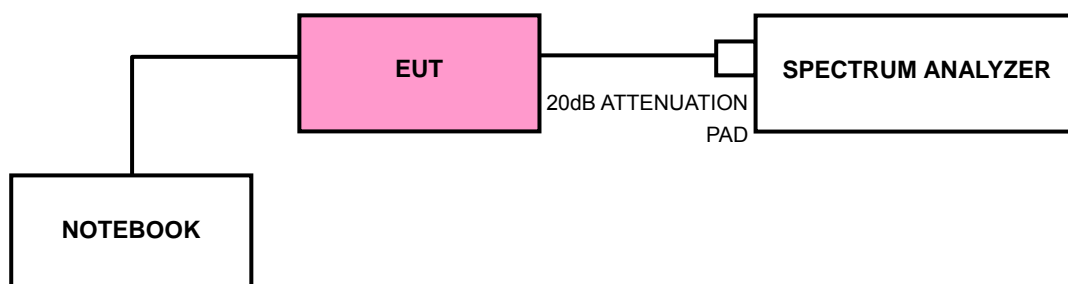

4.3.4 TEST PROCEDURES

- a. EUT connected to spectrum analyzer with a 20 dB attenuator.
- b. Notebook sends commands to control EUT to transmit at specific frequency, modulation and output power level via telnet utility. The power was measured with R&S Spectrum Analyzer. All measurements were done at 3 channels. (low, middle and high operational frequency range.)
- c. 26dBc bandwidth required a measurement bandwidth is the fundamental emission below 26dB bandwidth.

4.3.5 TEST RESULTS

FREQUENCY (MHz)	MAX. OUTPUT POWER -26 dBc BANDWIDTH (MHz)
2112.4	4.68
2132.4	4.68
2152.6	4.68

CH1537

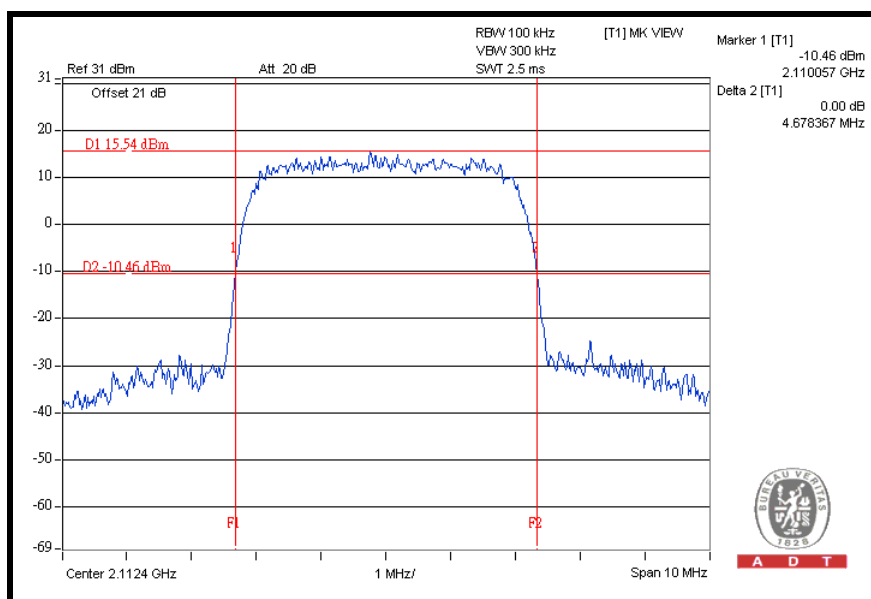

4.4 PEAK TO AVERAGE RATIO

4.4.1 LIMITS OF PEAK TO AVERAGE RATIO MEASUREMENT

In measuring transmissions in this band using an average power technique, the peak to-average ratio (PAR) of the transmission may not exceed 13 dB

4.4.2 TEST INSTRUMENTS

DESCRIPTION & MANUFACTURER	MODEL NO.	SERIAL NO.	DATE OF CALIBRATION	DUE DATE OF CALIBRATION
*Spectrum Analyzer Agilent	E4446A	MY48250266	Aug. 11, 2010	Aug. 10, 2011
* Mini-Circuits Power Splitter	ZN2PD-9G	NA	Jul. 14, 2010	Jul. 13, 2011
* Hewlett Packard RF cable	8120-6192	274388	Oct. 22, 2010	Oct. 21, 2011
* JFW 20dB attenuation	50HF-020-SMA	NA	NA	NA
* Suhner RF cable	Sucoflex104	246272	May 14, 2010	May 13, 2011

NOTE: 1. The calibration interval of the above test instruments is 12 months. And the calibrations are traceable to NML/ROC and NIST/USA.

2. "*" = These equipments are used for the final measurement.

4.4.3 TEST SETUP

Same as Item 4.2.4.

4.4.4 TEST PROCEDURES

1. Set resolution/measurement bandwidth \geq signal's occupied bandwidth.
2. Set the number of counts to a value that stabilizes the measured CCDF curve.
3. Record the maximum PAPR level associated with a probability of 0.1%.

4.4.5 EUT OPERATING CONDITION

Same as Item 4.1.5

4.4.6 TEST RESULTS

FREQUENCY (MHz)	PEAK TO AVERAGE RATIO (dB)
2112.4	7.86
2132.4	7.46
2152.6	7.59

CH 1537

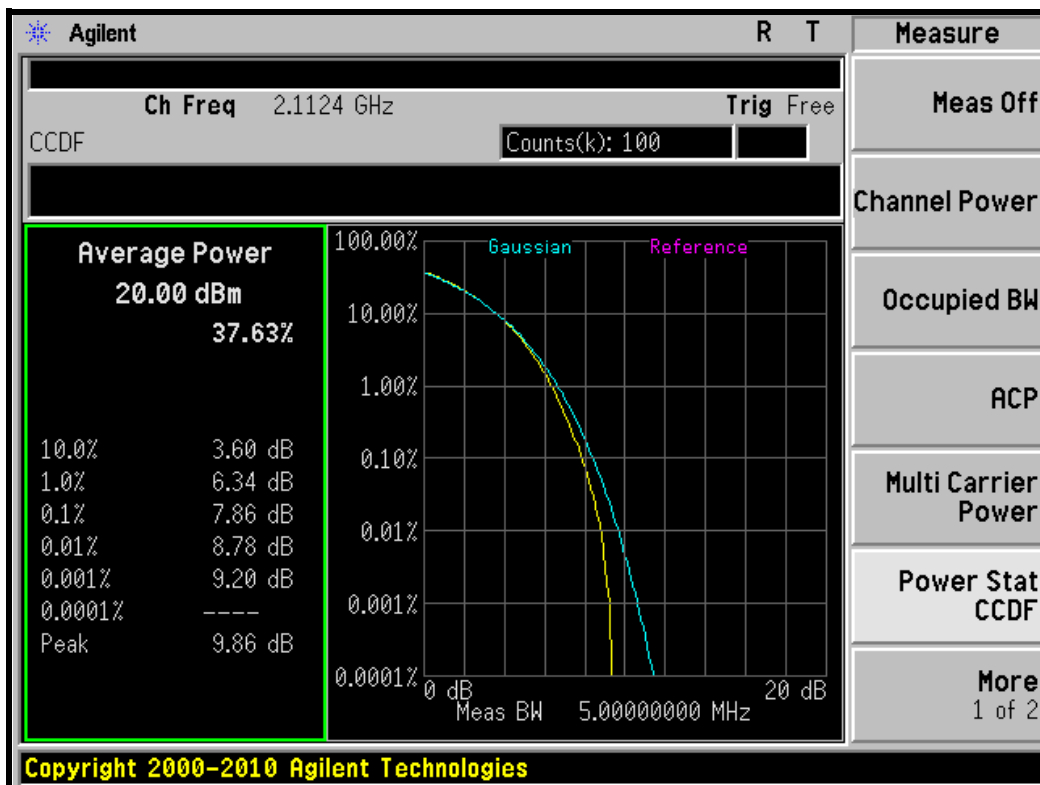

4.5 BAND EDGE MEASUREMENT

4.5.1 LIMITS OF BAND EDGE MEASUREMENT

For operations in the 698–746 MHz band, the power of any emission outside a licensee's frequency band(s) of operation shall be attenuated below the transmitter power (P) within the licensed band(s) of operation, measured in watts, by at least $43 + 10 \log (P)$ dB. Compliance with this provision is based on the use of measurement instrumentation employing a resolution bandwidth of 100 kilohertz or greater. However, in the 100 kilohertz bands immediately outside and adjacent to a licensee's frequency block, a resolution bandwidth of at least 30 kHz may be employed.

For operations in the 1710–1755 MHz and 2110–2155 MHz bands, the power of any emission outside a licensee's frequency block shall be attenuated below the transmitter power (P) by at least $43 + 10 \log_{10}(P)$ dB. The limit of emission equal to -13dBm . In the 1 MHz bands immediately outside and adjacent to the frequency block a resolution bandwidth of at least one percent of the emission bandwidth of the fundamental emission of the transmitter may be employed.

4.5.2 TEST INSTRUMENTS

DESCRIPTION & MANUFACTURER	MODEL NO.	SERIAL NO.	DATE OF CALIBRATION	DUE DATE OF CALIBRATION
* ROHDE & SCHWARZ Spectrum Analyzer	FSP40	100041	Jul. 09, 2010	Jul. 08, 2011
* Mini-Circuits Power Splitter	ZN2PD-9G	NA	Jul. 14, 2010	Jul. 13, 2011
* Hewlett Packard RF cable	8120-6192	274388	Oct. 22, 2010	Oct. 21, 2011
* JFW 20dB attenuation	50HF-020-SMA	NA	NA	NA
* Suhner RF cable	Sucoflex104	246272	May 14, 2010	May 13, 2011

NOTE: 1. The calibration interval of the above test instruments is 12 months. And the calibrations are traceable to NML/ROC and NIST/USA.

2. "*" = These equipments are used for the final measurement.

4.5.3 TEST SETUP

Same as Item 4.3.3

4.5.4 TEST PROCEDURES

- a. EUT connected to spectrum analyzer with a 20 dB attenuator
- b. NB sends commands to control EUT to transmit at specific frequency, modulation and output power level via telnet utility. The power was measured with R&S Spectrum Analyzer. All measurements were done at 2 channels (low and high operational frequency range.).
- c. This cable loss is the worst loss 1dB in the transmitted path track.
- d. The center frequency of spectrum is the band edge frequency and span is 1 MHz. RB of the spectrum is 100kHz and VB of the spectrum is 300kHz.
- e. Record the max trace plot into the test report.

4.5.5 EUT OPERATING CONDITION

Same as 4.1.5



A D T

4.5.6 TEST RESULTS

LOWER BAND EDGE

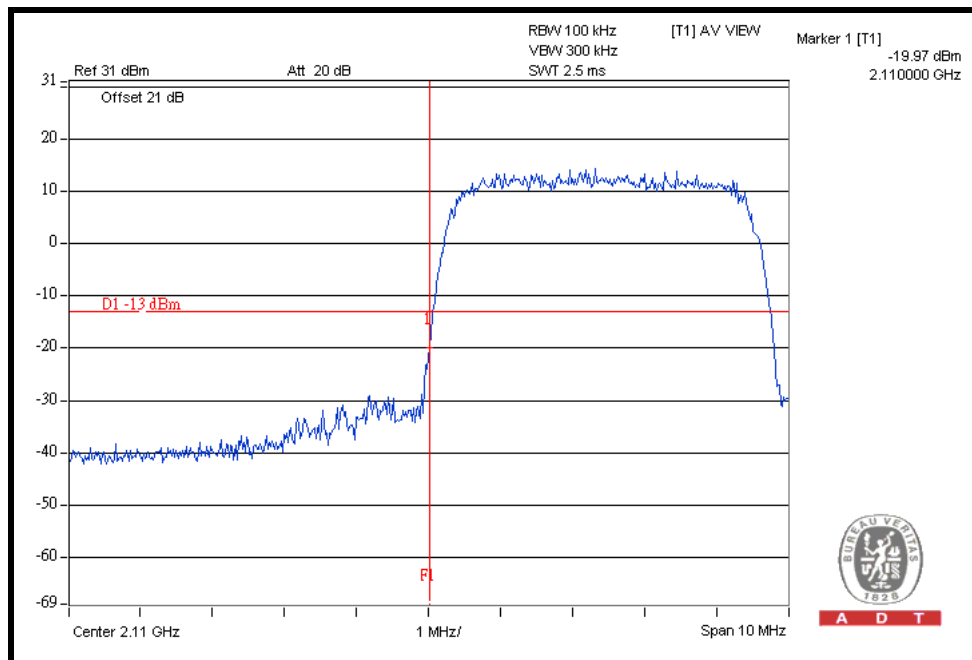

HIGHER BAND EDGE

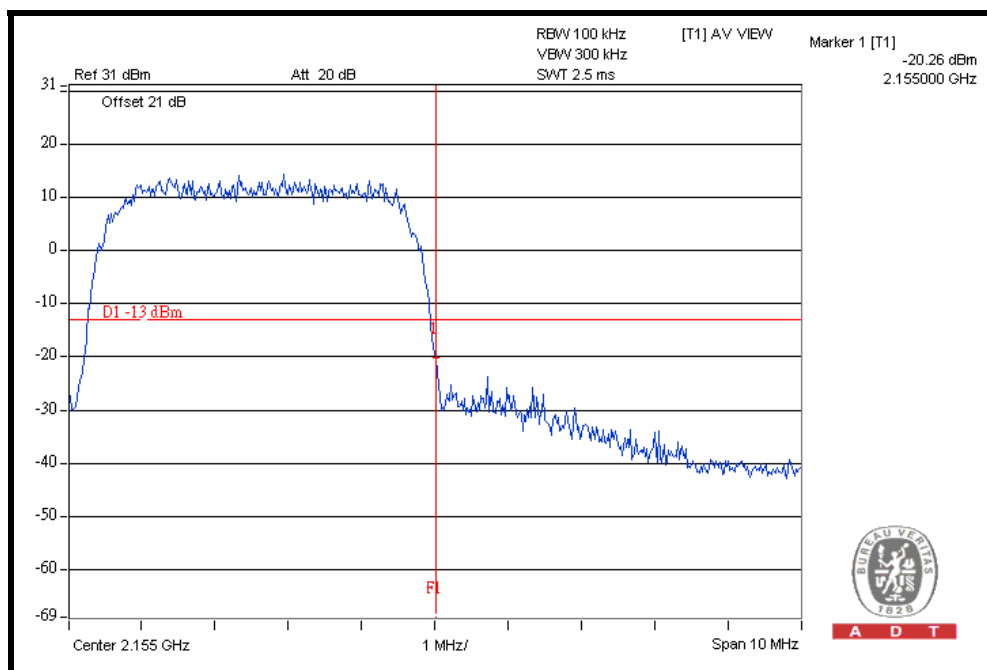

4.6 CONDUCTED SPURIOUS EMISSIONS

4.6.1 LIMITS OF CONDUCTED SPURIOUS EMISSIONS MEASUREMENT

The power of any emission outside a licensee's frequency block shall be attenuated below the transmitter power (P) by at least $43 + 10 \log_{10}(P)$ dB. The limit of emission equal to -13dBm

4.6.2 TEST INSTRUMENTS

DESCRIPTION & MANUFACTURER	MODEL NO.	SERIAL NO.	DATE OF CALIBRATION	DUE DATE OF CALIBRATION
* ROHDE & SCHWARZ Spectrum Analyzer	FSP40	100041	Jul. 09, 2010	Jul. 08, 2011
* Hewlett Packard RF cable	8120-6192	274388	Oct. 22, 2010	Oct. 21, 2011
* JFW 20dB attenuation	50HF-020-SMA	NA	NA	NA
* Suhner RF cable	Sucoflex104	246272	May 14, 2010	May 13, 2011

- NOTE:**
1. The calibration interval of the above test instruments is 12 months. And the calibrations are traceable to NML/ROC and NIST/USA.
 2. "*" = These equipments are used for the final measurement.

4.6.3 TEST PROCEDURE

- a. EUT connected to spectrum analyzer with a 20 dB attenuator
- b. NB sends commands to control EUT to transmit at specific frequency, modulation and output power level via telnet utility
- c. The EUT was set up for the maximum peak power with WCDMA link data modulation. The power was measured with R&S Spectrum Analyzer. All measurements were done at 3 channels (low, middle and high operational frequency range.).
- d. The spectrum set 1MHz/3MHz to measure conducted emission from 9kHz to 22GHz

4.6.4 TEST SETUP

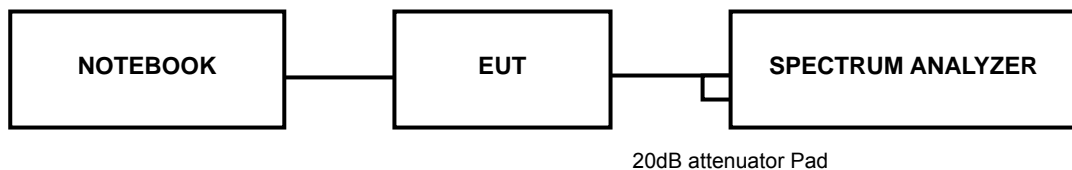

4.6.5 EUT OPERATING CONDITIONS

Same as 4.1.5

4.6.6 TEST RESULTS

CH 1537: 9kHz ~ 3GHz

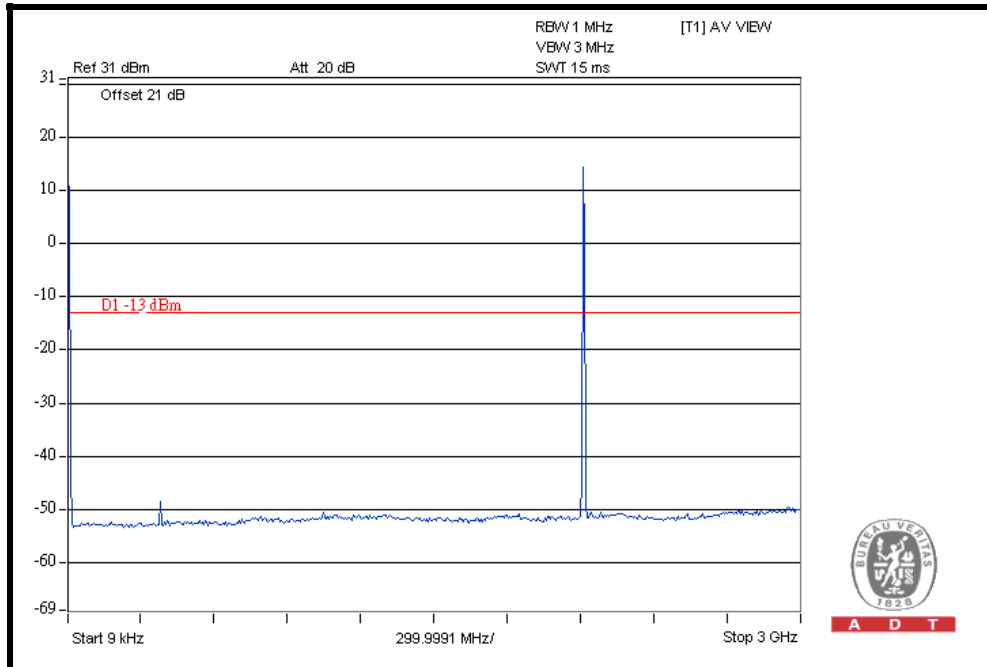

CH 1537: 3GHz ~ 10GHz

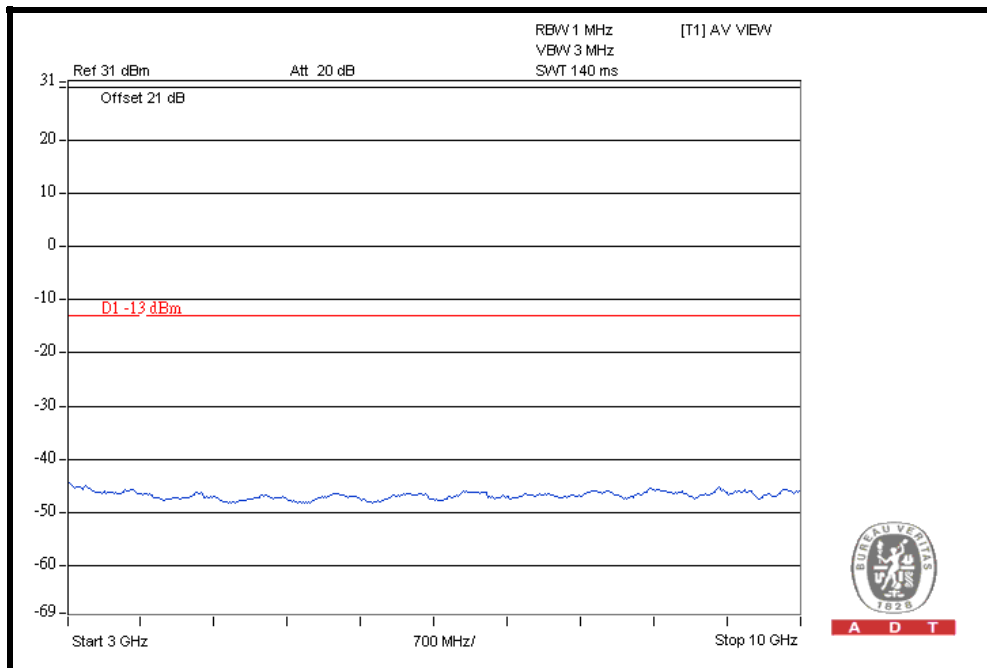



A D T

CH 1537: 10GHz ~ 22GHz

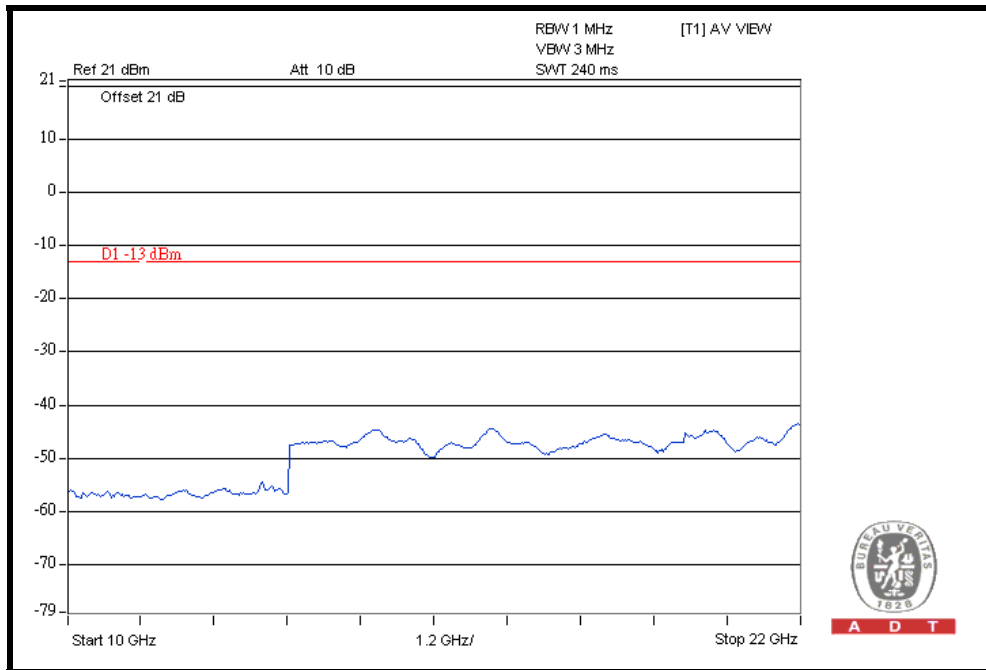

CH 1637: 9kHz ~ 3GHz

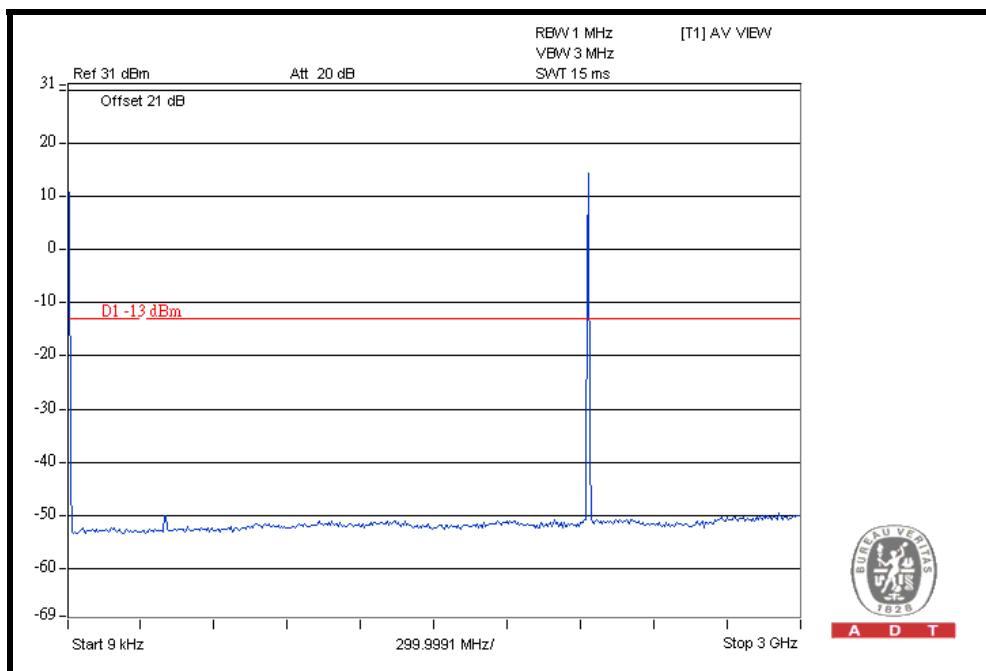



A D T

CH 1637: 3GHz ~ 10GHz

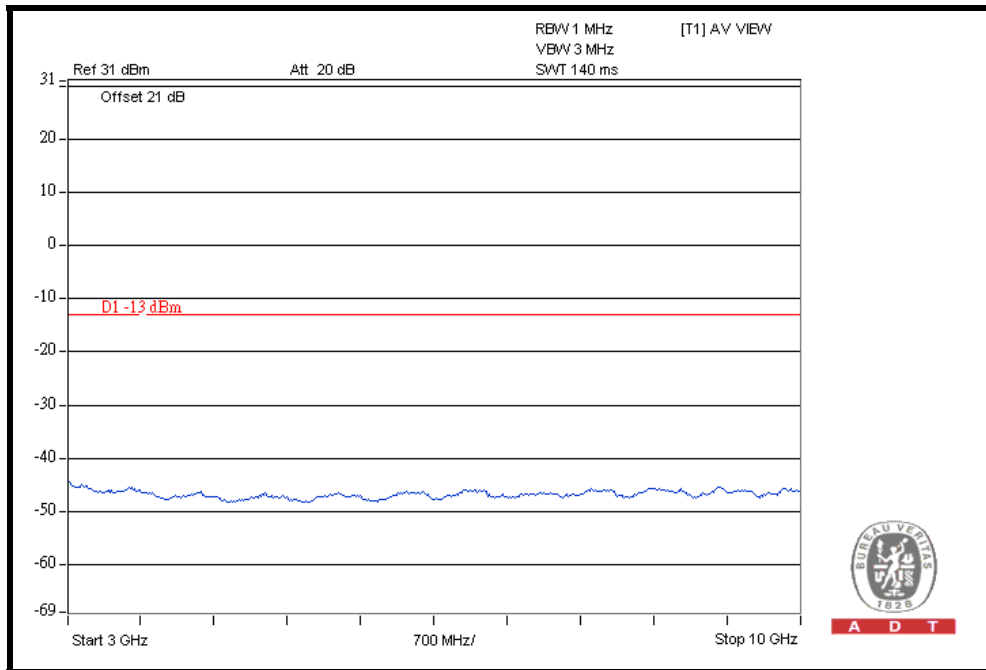

CH 1637: 10GHz ~ 22GHz

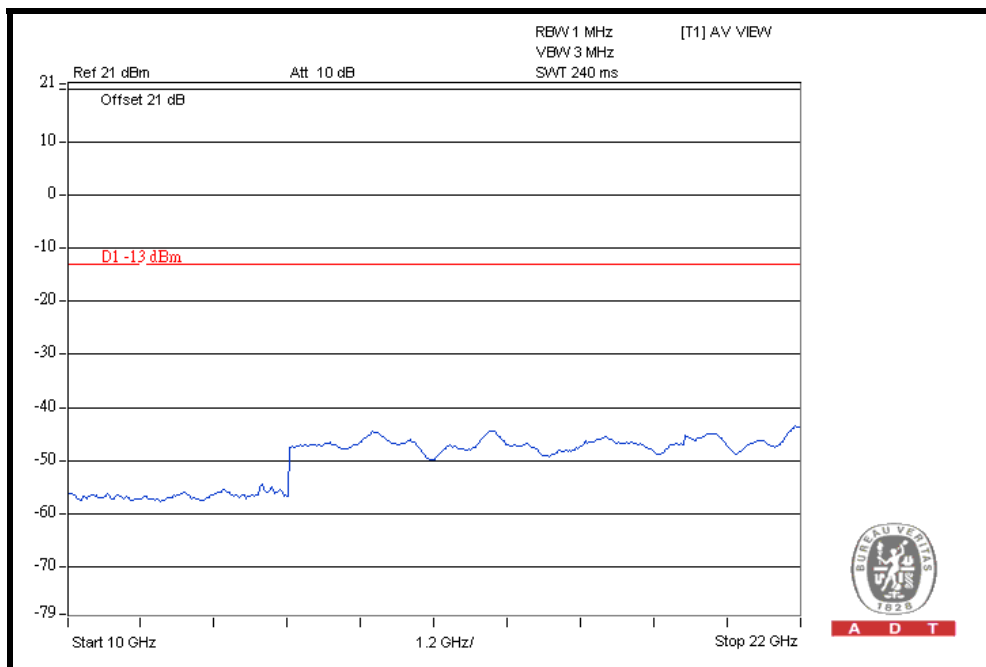



A D T

CH 1738: 9kHz ~ 3GHz

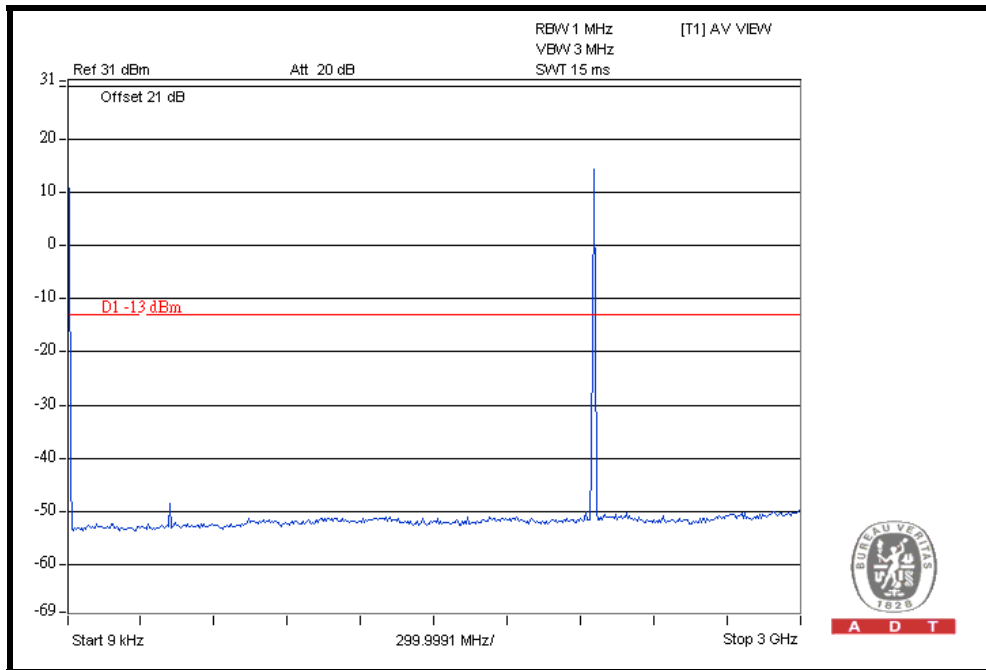

CH 1738: 3GHz ~ 10GHz

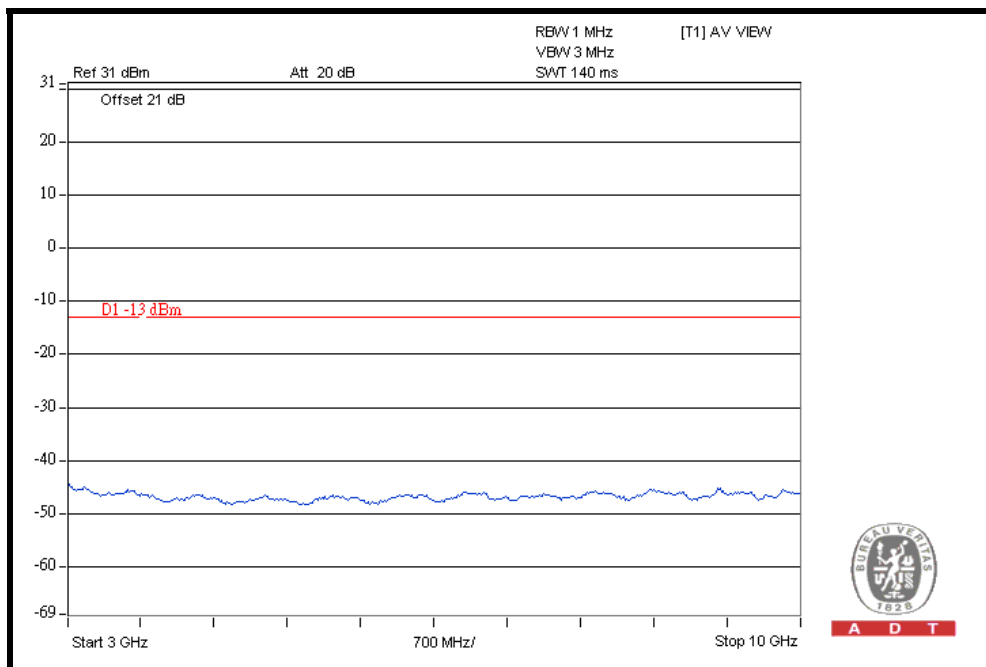



A D T

CH 1738: 10GHz ~ 22GHz

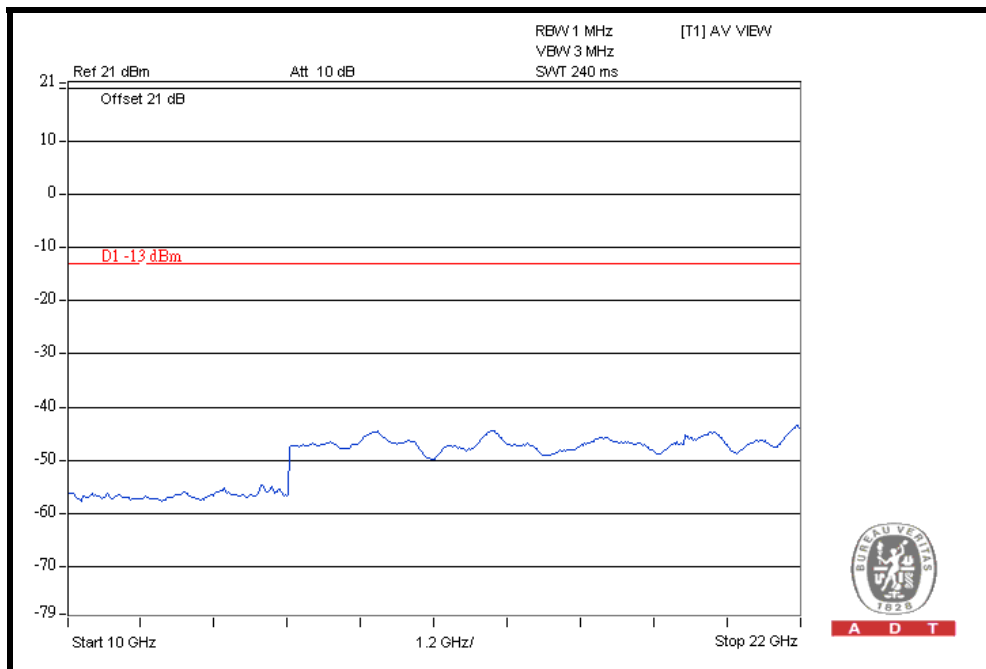

4.7 RADIATED EMISSION MEASUREMENT

4.7.1 LIMITS OF RADIATED EMISSION MEASUREMENT

The power of any emission outside a licensee's frequency block shall be attenuated below the transmitter power (P) by at least $43 + 10 \log_{10}(P)$ dB. The limit of emission equal to -13 dBm

So the limit of emission is the same absolute specified line.

LIMIT (dBm)	EQUIVALENT FIELD STRENGTH AT 3m (dBuV/m) (NOTE)
-13	82.22

NOTE: The following formula is used to convert the equipment radiated power to field strength.

$$E = [1000000 \sqrt{(30P)}] / 3 \text{ uV/m, where P is Watts.}$$

4.7.2 TEST INSTRUMENTS

DESCRIPTION & MANUFACTURER	MODEL NO.	SERIAL NO.	DATE OF CALIBRATION	DUE DATE OF CALIBRATION
Test Receiver ROHDE & SCHWARZ	ESCI	100424	Aug. 04, 2010	Aug. 03, 2011
Spectrum Analyzer ROHDE & SCHWARZ	FSP40	100041	Jul. 09, 2010	Jul. 08, 2011
BILOG Antenna SCHWARZBECK	VULB9168	9168-156	Apr. 12, 2011	Apr. 11, 2012
HORN Antenna SCHWARZBECK	BBHA 9120 D	9120D-209	Aug. 02, 2010	Aug. 01, 2011
HORN Antenna SCHWARZBECK	BBHA 9170	BBHA9170243	Dec. 27, 2010	Dec. 26, 2011
Preamplifier Agilent	8449B	3008A01910	Sep. 09, 2010	Sep. 08, 2011
Preamplifier Agilent	8447D	2944A10638	Nov. 03, 2010	Nov. 02, 2011
RF signal cable HUBER+SUHNNER	SUCOFLEX 104	218190/4 231241/4	May 14, 2010	May 13, 2011
RF signal cable Worken	8D-FB	Cable-HYCH9-01	Aug. 20, 2010	Aug. 19, 2011
Software	ADT_Radiated_ V7.6.15.9.2	NA	NA	NA
Antenna Tower EMCO	2070/2080	512.835.4684	NA	NA
Turn Table EMCO	2087-2.03	NA	NA	NA
Antenna Tower & Turn Table Controller EMCO	2090	NA	NA	NA
Turn Table Controller ADT.	SC100.	SC93021703	NA	NA

- NOTE:**
1. The calibration interval of the above test instruments is 12 months and the calibrations are traceable to NML/ROC and NIST/USA.
 2. The test was performed in HwaYa Chamber 9.
 3. The horn antenna and HP preamplifier (model: 8449B) are used only for the measurement of emission frequency above 1GHz if tested.
 4. The FCC Site Registration No. is 460141.
 5. The IC Site Registration No. is IC 7450F-4.

4.7.3 TEST PROCEDURES

- a. The EUT was placed on the top of a rotating table 0.8 meters above the ground. The table was rotated 360 degrees to determine the position of the highest radiation.
- b. The EUT was set 3 meters away from the receiving antenna, which was mounted on antenna tower and its position at 0.8 m above the ground.
- c. For each suspected emission, the EUT was arranged to its worst case and the rotatable table was turned from 0 degrees to 360 degrees to find the maximum reading and recorded the value.
- d. Repeat step a ~ c for horizontal polarization.

NOTE: The resolution bandwidth of spectrum analyzer is 1 MHz and the video bandwidth is 3 MHz.

4.7.4 DEVIATION FROM TEST STANDARD

No deviation

4.7.5 TEST SETUP

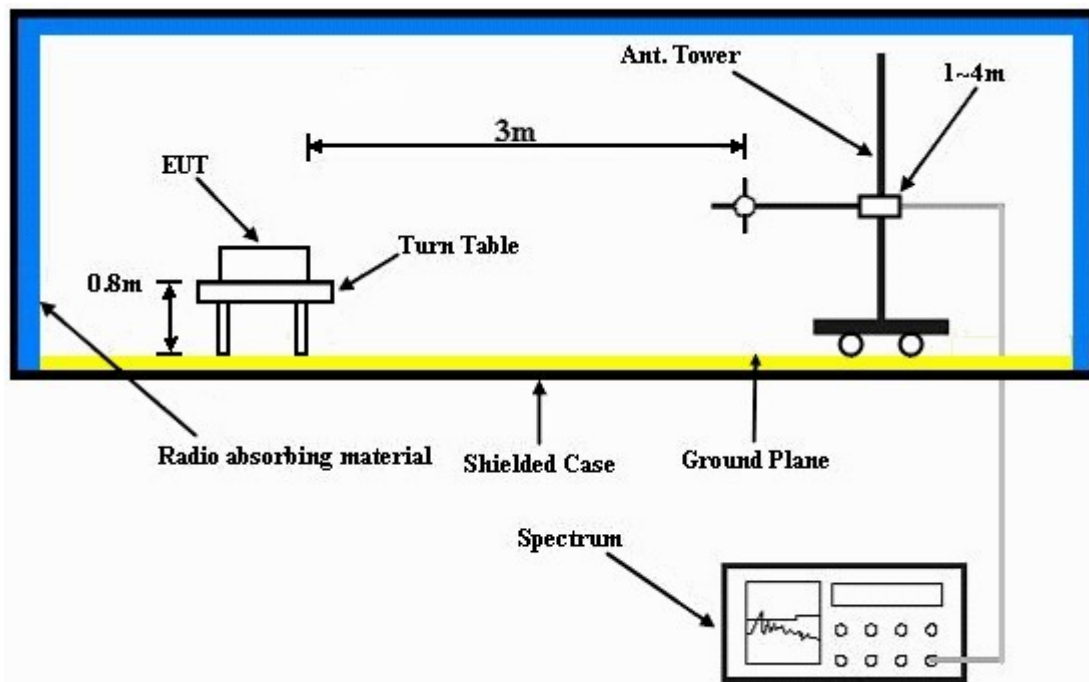

For the actual test configuration, please refer to the attached file (Test Setup Photo).

4.7.6 EUT OPERATING CONDITIONS

Same as 4.1.5

4.7.7 TEST RESULTS (Below 1GHz)

MODE	High channel	FREQUENCY RANGE	Below 1000MHz
-------------	--------------	------------------------	---------------

ANTENNA POLARITY & TEST DISTANCE: HORIZONTAL AT 3 M								
NO.	FREQ. (MHz)	EMISSION LEVEL (dBuV/m)	LIMIT (dBuV/m)	MARGIN (dB)	ANTENNA HEIGHT (m)	TABLE ANGLE (Degree)	RAW VALUE (dBuV)	CORRECTION FACTOR (dB/m)
1	125.68	43.4	82.22	-38.82	1.25 H	77	31.20	12.20
2	210.93	43.2	82.22	-39.02	1.50 H	228	31.90	11.30
3	249.66	41.8	82.22	-40.42	1.25 H	232	29.20	12.60
4	350.92	36.9	82.22	-45.32	1.25 H	123	21.30	15.60
5	480.28	39.2	82.22	-43.02	1.75 H	105	20.40	18.80
6	832.77	40.4	82.22	-41.82	1.25 H	208	15.70	24.70

ANTENNA POLARITY & TEST DISTANCE: VERTICAL AT 3 M								
NO.	FREQ. (MHz)	EMISSION LEVEL (dBuV/m)	LIMIT (dBuV/m)	MARGIN (dB)	ANTENNA HEIGHT (m)	TABLE ANGLE (Degree)	RAW VALUE (dBuV)	CORRECTION FACTOR (dB/m)
1	39.78	52.9	82.22	-29.32	1.25 V	277	39.30	13.60
2	99.37	42.5	82.22	-39.72	1.50 V	189	33.30	9.20
3	249.62	38.2	82.22	-44.02	1.50 V	53	25.60	12.60
4	401.48	37.8	82.22	-44.42	1.50 V	118	20.90	16.90
5	479.37	36.9	82.22	-45.32	1.00 V	125	18.20	18.70
6	753.68	39.2	82.22	-43.02	1.00 V	108	15.90	23.30

NOTE:

1. Emission level (dBuV/m) = Raw Value (dBuV) + Correction Factor (dB).
2. Correction Factor (dB/m) = Antenna Factor (dB/m) + Cable Factor (dB).
3. The other emission levels were very low against the limit.
4. Margin value = Emission level – Limit value.
5. This is valid for all 3 channels.



A D T

4.7.8 TEST RESULTS (Above 1GHz)

Test channel		Low channel				
ANTENNA POLARITY & TEST DISTANCE: HORIZONTAL AT 3m						
NO.	FREQ. (MHz)	EMISSION LEVEL (dBuV)	LIMIT (dBm)	S.G POWER VALUE (dBm)	CORRECTION FACTOR (dB)	POWER VALUE (dBm)
1	4224.8	52.8	-13.0	-51.2	9.7	-41.5
2	6337.2	56.8	-13.0	-46.2	8.7	-37.5
3	8449.6	52.1	-13.0	-50.0	7.7	-42.3
ANTENNA POLARITY & TEST DISTANCE: VERTICAL AT 3m						
NO.	FREQ. (MHz)	EMISSION LEVEL (dBuV)	LIMIT (dBm)	S.G POWER VALUE (dBm)	CORRECTION FACTOR (dB)	POWER VALUE (dBm)
1	4224.8	49.1	-13.0	-54.9	9.7	-45.2
2	6337.2	65.5	-13.0	-37.5	8.7	-28.8
3	8449.6	54.0	-13.0	-48.1	7.7	-40.4

Test channel		Middle channel				
ANTENNA POLARITY & TEST DISTANCE: HORIZONTAL AT 3m						
NO.	FREQ. (MHz)	EMISSION LEVEL (dBuV)	LIMIT (dBm)	S.G POWER VALUE (dBm)	CORRECTION FACTOR (dB)	POWER VALUE (dBm)
1	4264.8	58.7	-13.0	-45.5	9.7	-35.8
2	6397.2	62.6	-13.0	-40.6	8.7	-31.9
3	8529.6	53.1	-13.0	-48.9	7.7	-41.2
ANTENNA POLARITY & TEST DISTANCE: VERTICAL AT 3m						
NO.	FREQ. (MHz)	EMISSION LEVEL (dBuV)	LIMIT (dBm)	S.G POWER VALUE (dBm)	CORRECTION FACTOR (dB)	POWER VALUE (dBm)
1	4264.8	54.4	-13.0	-49.8	9.7	-40.1
2	6397.2	63.7	-13.0	-39.5	8.7	-30.8
3	8529.6	54.7	-13.0	-47.3	7.7	-39.6

NOTE: EIRP(dBm) = S.G Power Value (dBm) + Correction Factor (dB).

Correction Factor = gain of substitution antenna + cable loss



A D T

Test channel		High channel				
ANTENNA POLARITY & TEST DISTANCE: HORIZONTAL AT 3m						
NO.	FREQ. (MHz)	EMISSION LEVEL (dBuV)	LIMIT (dBm)	S.G POWER VALUE (dBm)	CORRECTION FACTOR (dB)	POWER VALUE (dBm)
1	4305.2	55.9	-13.0	-48.2	9.7	-38.5
2	6457.8	62.1	-13.0	-40.6	8.5	-32.1
3	8610.4	48.4	-13.0	-53.4	7.7	-45.7
ANTENNA POLARITY & TEST DISTANCE: VERTICAL AT 3m						
NO.	FREQ. (MHz)	EMISSION LEVEL (dBuV)	LIMIT (dBm)	S.G POWER VALUE (dBm)	CORRECTION FACTOR (dB)	POWER VALUE (dBm)
1	4305.2	49.7	-13.0	-54.4	9.7	-44.7
2	6457.8	64.6	-13.0	-38.1	8.5	-29.6
3	8610.4	52.7	-13.0	-49.1	7.7	-41.4

NOTE: EIRP(dBm) = S.G Power Value (dBm) + Correction Factor (dB).
Correction Factor = gain of substitution antenna + cable loss

5 INFORMATION ON THE TESTING LABORATORIES

We, Bureau Veritas Consumer Products Services (H.K.) Ltd., Taoyuan Branch, were founded in 1988 to provide our best service in EMC, Radio, Telecom and Safety consultation. Our laboratories are accredited and approved according to ISO/IEC 17025.

Copies of accreditation certificates of our laboratories obtained from approval agencies can be downloaded from our web site: www.adt.com.tw/index.5.phtml.
If you have any comments, please feel free to contact us at the following:

Linko EMC/RF Lab:
Tel: 886-2-26052180
Fax: 886-2-26051924

Hsin Chu EMC/RF Lab:
Tel: 886-3-5935343
Fax: 886-3-5935342

Hwa Ya EMC/RF/Safety/Telecom Lab: Web Site: www.adt.com.tw
Tel: 886-3-3183232
Fax: 886-3-3185050

The address and road map of all our labs can be found in our web site also.



A D T

6 APPENDIX A – MODIFICATIONS RECORDERS FOR ENGINEERING CHANGES TO THE EUT BY THE LAB

No any modifications are made to the EUT by the lab during the test.

---END---