

FCC RF Test Report

APPLICANT : MitraStar Technology Corporation
EQUIPMENT : TD-LTE Outdoor CPE
BRAND NAME : Huawei; MitraStar
MODEL NAME : B222s-41(Huawei) ;
M4G-301M2W/M4G-301M1W/M4G-301M-12V(MitraStar)
FCC ID : ZMYM4G-301
STANDARD : 47 CFR Part 2, 27
CLASSIFICATION : PCS Licensed Transmitter (PCB)
TX FREQUENCY RANGE : 2496 MHz ~ 2690 MHz
RX FREQUENCY RANGE : 2496 MHz ~ 2690 MHz
MAX. ERP/EIRP POWER : 2.404 W (LTE Band 41 QPSK, 10MHz)
2.344 W (LTE Band 41 16QAM, 10MHz)
2.421 W (LTE Band 41 QPSK, 20MHz)
2.723 W (LTE Band 41 16QAM, 20MHz)

The product was received on Mar. 13, 2012 and completely tested on May 15, 2012. We, SPORTON INTERNATIONAL INC., would like to declare that the tested sample has been evaluated in accordance with the procedures given in ANSI / TIA / EIA-603-C-2004 and shown compliance with the applicable technical standards.

The test results in this report apply exclusively to the tested model / sample. Without written approval of SPORTON INTERNATIONAL INC., the test report shall not be reproduced except in full.

Reviewed by:



Jones Tsai / Manager



SPORTON INTERNATIONAL INC.

No. 52, Hwa Ya 1st Rd., Hwa Ya Technology Park, Kwei-Shan Hsiang, Tao Yuan Hsien, Taiwan, R.O.C.



TABLE OF CONTENTS

REVISION HISTORY..... 3
SUMMARY OF TEST RESULT 4
1 GENERAL DESCRIPTION 5
1.1 Applicant 5
1.2 Manufacturer 5
1.3 Feature of Equipment Under Test 5
1.4 Emission Designator 6
1.5 Testing Site 6
1.6 Applied Standards 7
1.7 Ancillary Equipment List 7
2 TEST CONFIGURATION OF EQUIPMENT UNDER TEST 8
2.1 Test Mode 8
2.2 Connection Diagram of Test System 8
3 TEST RESULT 9
3.1 Conducted Output Power Measurement 9
3.2 Effective Radiated Power and Equivalent Isotropic Radiated Power Measurement 11
3.3 Occupied Bandwidth 15
3.4 Band Edge Measurement 18
3.5 Conducted Emission Measurement 23
3.6 Field Strength of Spurious Radiation Measurement 30
3.7 Frequency Stability Measurement 36
4 LIST OF MEASURING EQUIPMENTS 38
5 UNCERTAINTY OF EVALUATION 39
APPENDIX A. PHOTOGRAPHS OF EUT
APPENDIX B. SETUP PHOTOGRAPHS



REVISION HISTORY

REPORT NO.	VERSION	DESCRIPTION	ISSUED DATE
FG231333	Rev. 01	Initial issue of report	Jun. 14, 2012
FG231333	Rev. 02	Modified description of section 3.2 Equivalent Isotropic Radiated Power	Jun. 21, 2012



SUMMARY OF TEST RESULT

Report Section	FCC Rule	Description	Limit	Result	Remark
3.1	§2.1046 §27.50(h)(2)	Conducted Output Power	Output Power < 2 Watts	PASS	
3.2	§27.50(h)(1)(ii)	Equivalent Isotropic Radiated Power	< 33 dBW + 10 log(X/Y) dBW + 10 log(360/beamwidth) dBW	PASS	-
3.3	§2.1049	Occupied Bandwidth	NA	PASS	-
3.4	§2.1049 §27.53(m)	Emission Mask Measurement	< 43+10log ₁₀ (P[Watts])	PASS	-
3.5	§2.1051 §27.53(m)	Conducted Emission	< 43+10log ₁₀ (P[Watts])	PASS	-
3.6	§2.1053 §27.53(m)	Undesirable Out of Band Emissions	< 43+10log ₁₀ (P[Watts])	PASS	Under limit 15.56 dB at 10720.000 MHz -
3.7	§2.1055 §27.54	Frequency Stability Temperature & Voltage	< 2.5 ppm	PASS	



1 General Description

1.1 Applicant

MitraStar Technology Corporation

No. 6, Innovation Road II Hsinchu Science Park, Hsinchu 300

1.2 Manufacturer

MitraStar Technology Corporation

No. 6, Innovation Road II Hsinchu Science Park, Hsinchu 300

1.3 Feature of Equipment Under Test

Product Feature & Specification	
Equipment	TD-LTE Outdoor CPE
Brand Name	Huawei; MitraStar
Model Name	B222s-41(Huawei) ; M4G-301M2W/M4G-301M1W/M4G-301M-12V(MitraStar)
FCC ID	ZMYM4G-301
Sample 1	EUT with two RJ-11 Ports
Sample 2	EUT with one RJ-11 Port
Tx Frequency	2496 MHz ~ 2690 MHz
Rx Frequency	2496 MHz ~ 2690 MHz
Bandwidth	10MHz / 20MHz
Maximum Output Power to Antenna	26.04 dBm
Antenna Type	Patch Antenna
EUT Stage	Production Unit

1.4 Emission Designator

FCC Rule	System	Type of Modulation	BW	Emission Designator	Maximum ERP/EIRP
Part 27	LTE Band 41	QPSK	10MHz	9M00G7D	2.404 W
Part 27	LTE Band 41	16QAM	10MHz	9M08D7W	2.344 W
Part 27	LTE Band 41	QPSK	20MHz	18M72G7D	2.421 W
Part 27	LTE Band 41	16QAM	20MHz	18M48D7W	2.723 W

1.5 Testing Site

Test Site	SPORTON INTERNATIONAL INC.		
Test Site Location	No. 52, Hwa Ya 1 st Rd., Hwa Ya Technology Park, Kwei-Shan Hsiang, Tao Yuan Hsien, Taiwan, R.O.C. TEL: +886-3-327-3456 FAX: +886-3-328-4978		
Test Site No.	Sporton Site No.		FCC/IC Registration No.
	TH02-HY	03CH07-HY	TW1022/4086B-1



1.6 Applied Standards

According to the specifications of the manufacturer, the EUT must comply with the requirements of the following standards:

- ♦ 47 CFR Part 2, 27
- ♦ ANSI / TIA / EIA-603-C-2004
- ♦ FCC KDB 971168 D01 Power Meas. License Digital Systems v01

Remark:

1. All test items were verified and recorded according to the standards and without any deviation during the test.
2. This EUT has also been tested and complied with the requirements of FCC Part 15, Subpart B, recorded in a separate test report.

1.7 Ancillary Equipment List

Item	Equipment	Trade Name	Model No.	FCC ID	Data Cable	Power Cord
1.	System Simulator	R&S	CMW500	N/A	N/A	Unshielded, 1.8 m

2 Test Configuration of Equipment Under Test

2.1 Test Mode

During all testing, EUT is in link mode with base station emulator at maximum power level. The spurious emission measurements were carried out in semi-anechoic chamber with 3-meter test range.

Frequency range investigated for radiated emission: 30MHz to 10th harmonic.

Test Modes			
Band		Radiated TCs	Conducted TCs
LTE Band 41	BW 10MHz	<ul style="list-style-type: none"> ■ LTE (RB Size 1, RB Offset 0) Link for Sample 2 	<ul style="list-style-type: none"> ■ LTE (RB Size 1, RB Offset 0) Link ■ LTE (RB Size 1, RB Offset 49) Link ■ LTE (RB Size 25, RB Offset 0) Link
	BW 20MHz	<ul style="list-style-type: none"> ■ LTE (RB Size 1, RB Offset 0) Link for Sample 2 	<ul style="list-style-type: none"> ■ LTE (RB Size 1, RB Offset 0) Link ■ LTE (RB Size 1, RB Offset 99) Link ■ LTE (RB Size 1, RB Offset 100) Link

2.2 Connection Diagram of Test System

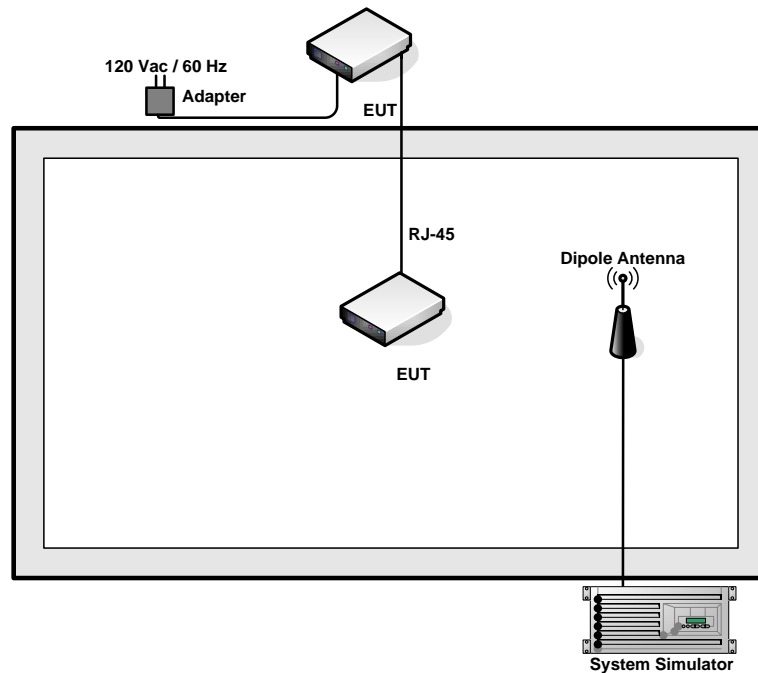

3 Test Result

3.1 Conducted Output Power Measurement

3.1.1 Description of the Conducted Output Power Measurement

A base station simulator was used to establish communication with the EUT. Its parameters were set to transmit the maximum power on the EUT. The measured power in the radio frequency on the transmitter output terminals shall be reported.

Follow FCC rule Part 27.50(h)(2), all user stations are limited to 2.0 watts transmitter output power.

3.1.2 Measuring Instruments

See list of measuring instruments of this test report.

3.1.3 Test Procedures

1. The transmitter output port was connected to base station.
2. Set EUT at maximum power through base station.
3. Select lowest, middle, and highest channels for each band and different modulation.

3.1.4 Test Setup

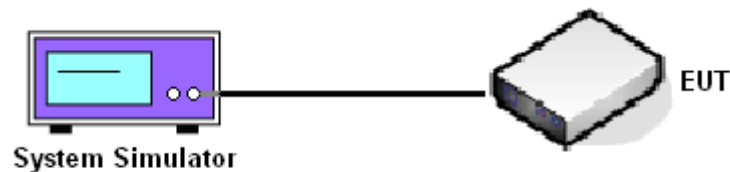



3.1.5 Test Result of Conducted Output Power

Operation Band	Band Width	Modulation	Channel	Frequency (MHz)	Conducted Power (dBm)	Conducted Power (Watts)	PAPR (dB)
LTE Band 41	10MHz	QPSK	39700	2501	25.42	0.3483	5.40
			40620	2593	25.86	0.3855	5.40
			41540	2685	26.04	0.4018	5.40
		16QAM	39700	2501	25.93	0.3917	6.00
			40620	2593	25.77	0.3776	6.00
			41540	2685	25.97	0.3954	6.00
	20MHz	QPSK	39750	2506	25.53	0.3573	6.36
			40620	2593	25.69	0.3707	6.36
			41490	2680	26.00	0.3981	6.36
		16QAM	39750	2506	25.73	0.3741	7.12
			40620	2593	25.94	0.3926	7.12
			41490	2680	25.97	0.3954	7.12



3.2 Equivalent Isotropic Radiated Power Measurement

3.2.1 Description of the EIRP Measurement

The device used one or more transmitting antennas with a non-omnidirectional horizontal plane radiation pattern, the maximum EIRP in dBW in a given direction shall be determined by the following formula: $EIRP = 33 \text{ dBW} + 10 \log(X/Y) \text{ dBW} + 10 \log(360/\text{beamwidth}) \text{ dBW}$, where X is the actual channel width in MHz, Y is either (i) 6 MHz if prior to transition or the station is in the MBS following transition or (ii) 5.5 MHz if the station is in the LBS and UBS following transition, and beamwidth is the total horizontal plane beamwidth of the individual transmitting antenna for the station or any sector measured at the half-power points.

Minimum EIRP Limit = $33 + 10 \log(10/6) + 10 \log(360/38) = 44.98 \text{ dBW}$

(X= 10, 20MHz, Y=5.5, 6MHz, beamwidth = 34~38)

Effective isotropic radiated power output measurements by substitution method according to ANSI / TIA / EIA-603-C-2004, and the spectrum analyzer configuration follows KDB 971168 D01 Power Meas. License Digital Systems v01.

3.2.2 Measuring Instruments

See list of measuring instruments of this test report.

3.2.3 Test Procedures

1. The EUT was placed on a non-conductive rotating platform with 0.8 meter height in a semi-anechoic chamber. The radiated emission at the fundamental frequency was measured at 3 m with a test antenna and a spectrum analyzer with RBW= 300KHz, VBW= 1MHz for BW 10MHz, RBW= 1MHz, VBW= 3MHz for BW 20MHz, RMS detector, and used Channel Power function with measurement bandwidth = 10MHz/20MHz per section 4.0 of KDB 971168 D01.
2. During the measurement, the EUT was enforced in maximum power and linked with a base station. The highest emission was recorded from analyzer power level (LVL) from the 360 degrees rotation of the turntable and the test antenna raised and lowered over a range from 1 to 4 meters in both horizontally and vertically polarized orientations.
3. Effective Isotropic Radiated Power (EIRP) was measured by substitution method according to TIA/EIA-603-C. The EUT was replaced by dipole antenna (substitution antenna) at same location, and then a known power from S.G. was applied into the dipole antenna through a Tx cable, and then recorded the maximum Analyzer reading through raised and lowered the test antenna. The correction factor (in dB) = S.G. - Tx Cable loss + Substitution antenna gain - Analyzer reading. Then the EUT's EIRP was calculated with the correction factor, $EIRP = LVL + \text{Correction factor}$.

3.2.4 Test Setup

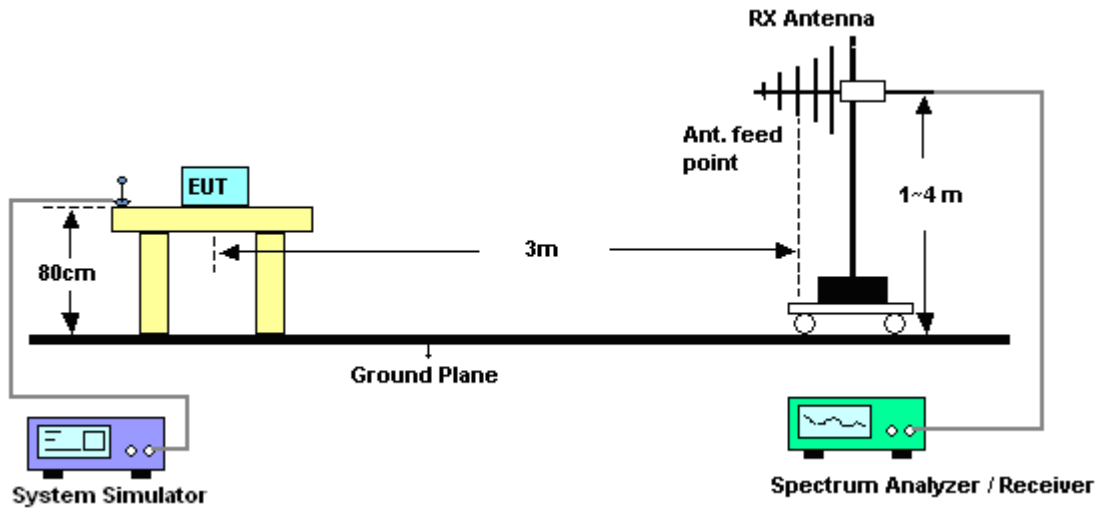

3.2.5 Test Result of ERP/EIRP

LTE Band 41 Radiated Power EIRP for BW 10MHz (QPSK, 1RB Size, RB Offset 0)				
Horizontal Polarization				
Frequency (MHz)	LVL (dBm)	Correction Factor (dB)	EIRP (dBm)	EIRP (W)
2501.00	-12.37	43.61	31.24	1.330
2593.00	-12.03	44.02	31.99	1.581
2685.00	-12.22	44.43	32.21	1.663
Vertical Polarization				
Frequency (MHz)	LVL (dBm)	Correction Factor (dB)	EIRP (dBm)	EIRP (W)
2501.00	-13.39	45.37	31.98	1.578
2593.00	-12.05	45.69	33.64	2.312
2685.00	-12.43	46.24	33.81	2.404

LTE Band 41 Radiated Power EIRP for BW 10MHz (16QAM, 1RB Size, RB Offset 0)				
Horizontal Polarization				
Frequency (MHz)	LVL (dBm)	Correction Factor (dB)	EIRP (dBm)	EIRP (W)
2501.00	-12.32	43.61	31.29	1.346
2593.00	-12.04	44.02	31.98	1.578
2685.00	-12.24	44.43	32.19	1.656
Vertical Polarization				
Frequency (MHz)	LVL (dBm)	Correction Factor (dB)	EIRP (dBm)	EIRP (W)
2501.00	-13.37	45.37	32.00	1.585
2593.00	-12.07	45.69	33.62	2.301
2685.00	-12.54	46.24	33.70	2.344



LTE Band 41 Radiated Power EIRP for BW 20MHz (16QAM, 1RB Size, RB Offset 0)				
Horizontal Polarization				
Frequency (MHz)	LVL (dBm)	Correction Factor (dB)	EIRP (dBm)	EIRP (W)
2506.00	-12.58	43.67	31.09	1.285
2593.00	-11.69	44.02	32.33	1.710
2680.00	-12.25	44.4	32.15	1.641
Vertical Polarization				
Frequency (MHz)	LVL (dBm)	Correction Factor (dB)	EIRP (dBm)	EIRP (W)
2506.00	-13.70	45.1	31.40	1.380
2593.00	-12.21	45.69	33.48	2.228
2680.00	-12.27	46.11	33.84	2.421

LTE Band 4 Radiated Power EIRP for BW 20MHz (QPSK, 1RB Size, RB Offset 0)				
Horizontal Polarization				
Frequency (MHz)	LVL (dBm)	Correction Factor (dB)	EIRP (dBm)	EIRP (W)
2506.00	-12.32	43.67	31.35	1.365
2593.00	-11.15	44.02	32.87	1.936
2680.00	-12.26	44.4	32.14	1.637
Vertical Polarization				
Frequency (MHz)	LVL (dBm)	Correction Factor (dB)	EIRP (dBm)	EIRP (W)
2506.00	-13.24	45.1	31.86	1.535
2593.00	-11.34	45.69	34.35	2.723
2680.00	-13.06	46.11	33.05	2.018

3.3 Occupied Bandwidth

3.3.1 Description of Occupied Bandwidth Measurement

The occupied bandwidth is the width of a frequency band such that, below the lower and above the upper frequency limits, the mean powers emitted are each equal to a specified percentage 0.5% of the total mean transmitted power.

3.3.2 Measuring Instruments

See list of measuring instruments of this test report.

3.3.3 Test Procedures

4. The EUT was connected to Spectrum Analyzer and Base Station via power divider.
5. The 99% occupied bandwidth (BW) of the middle channel for the highest RF powers with full RB sizes were measured.

3.3.4 Test Setup

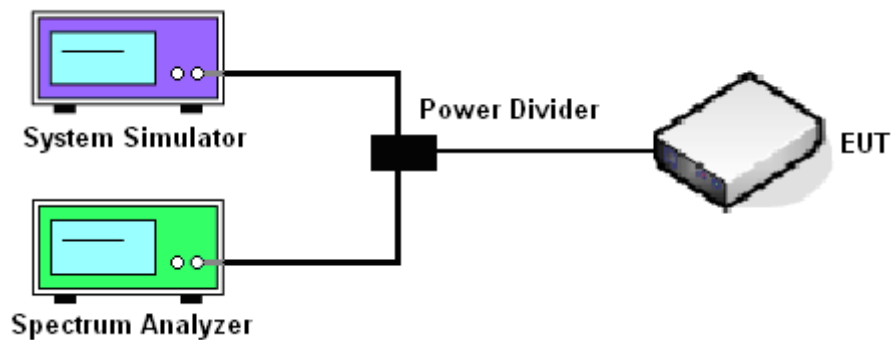



3.3.5 Test Result (Plots) of Occupied Bandwidth

Band :	LTE Band 41	BW / Mod. :	10MHz / QPSK
--------	-------------	-------------	--------------

99% Occupied Bandwidth Plot on Channel 20175

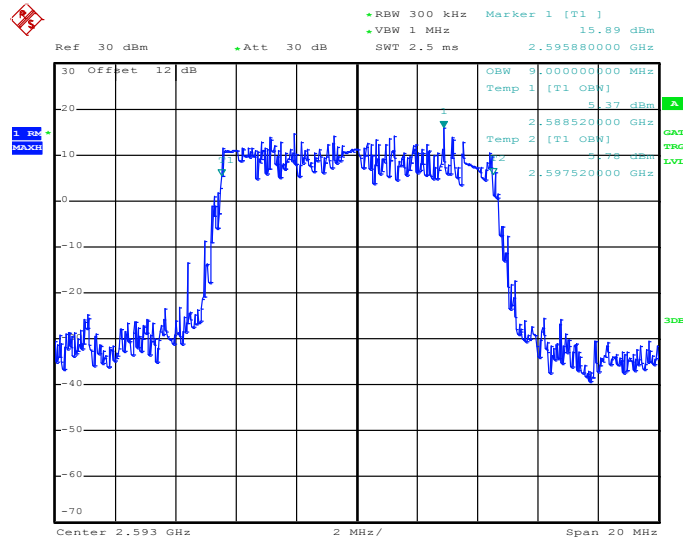

Date: 2.APR.2012 10:41:22

Band :	LTE Band 41	BW / Mod. :	10MHz / 16QAM
--------	-------------	-------------	---------------

99% Occupied Bandwidth Plot on Channel 20175

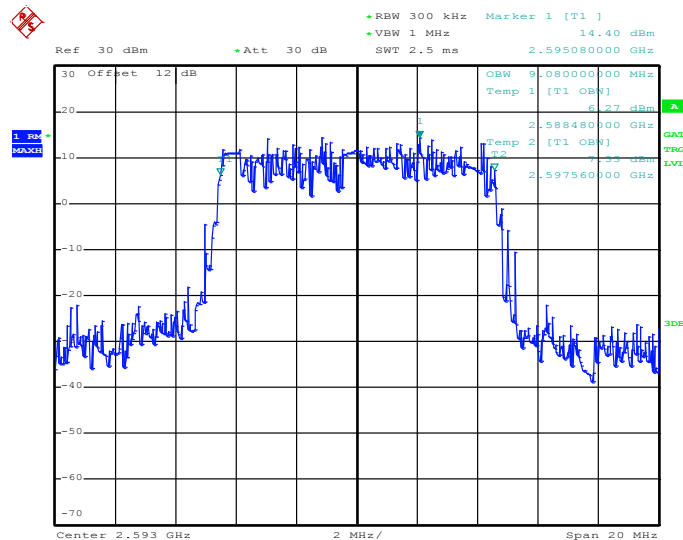

Date: 2.APR.2012 10:41:53



Band :	LTE Band 41	BW / Mod. :	20MHz / QPSK
---------------	-------------	--------------------	--------------

99% Occupied Bandwidth Plot on Channel 20175

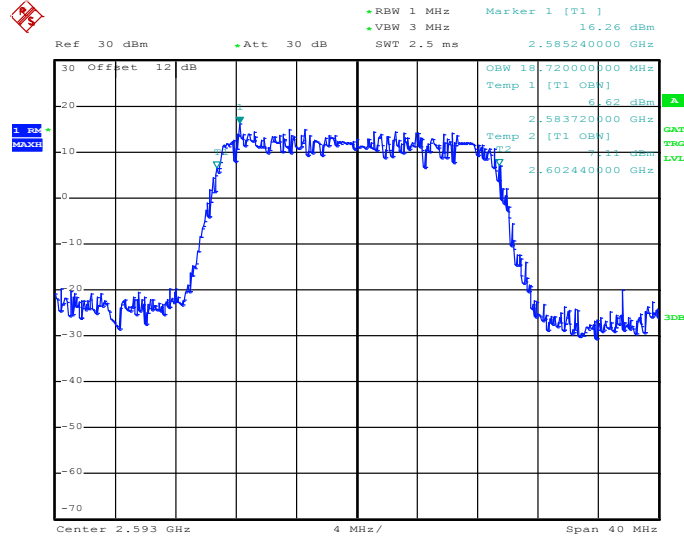

Date: 2.APR.2012 11:22:55

Band :	LTE Band 41	BW / Mod. :	20MHz / 16QAM
---------------	-------------	--------------------	---------------

99% Occupied Bandwidth Plot on Channel 20175

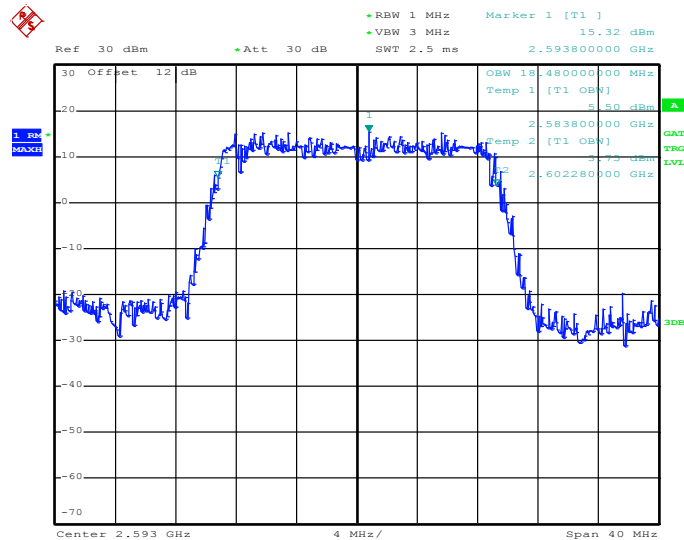

Date: 2.APR.2012 11:21:31

3.4 Band Edge Measurement

3.4.1 Limit

The emissions be operated in the 2496-2690 MHz band, the FCC limit is $43 + 10\log_{10}(P[\text{Watts}])$ dB = -13 dBm in a 1MHz bandwidth.

3.4.2 Measuring Instruments

See list of measuring instruments of this test report.

3.4.3 Test Procedures

1. The EUT was connected to Spectrum Analyzer and Base Station via power divider.
2. The band edges of low and high channels for the highest RF powers were measured. Setting RBW = 1MHz.

3.4.4 Test Setup

<Conducted Band Edge >

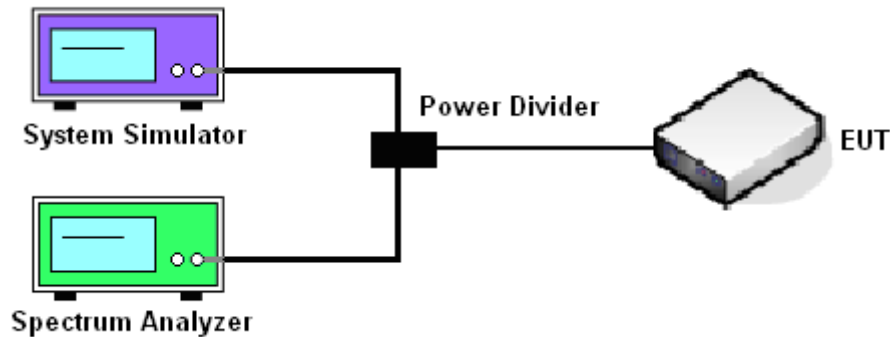



3.4.5 Test Result (Plots) of Conducted Band Edge

Band :	LTE Band 41	Band Width	10MHz
---------------	-------------	-------------------	-------

Lower Band Edge Plot for QPSK-RB Size 1, RB Offset 0

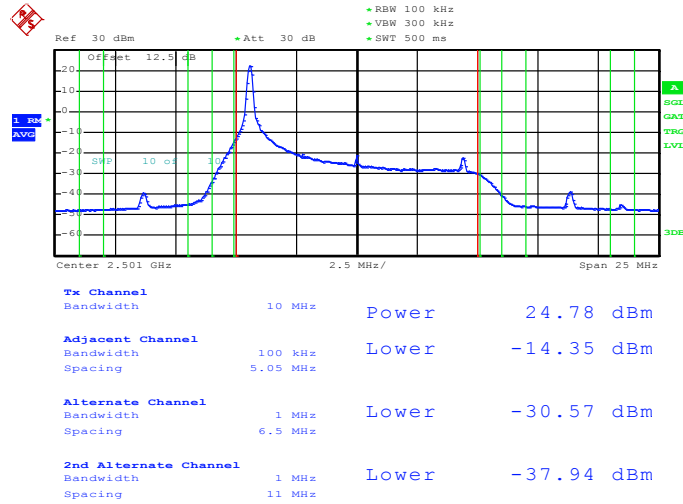

Date: 2.MAY.2012 00:04:12

Lower Band Edge Plot for QPSK-RB Size 25, RB Offset 0

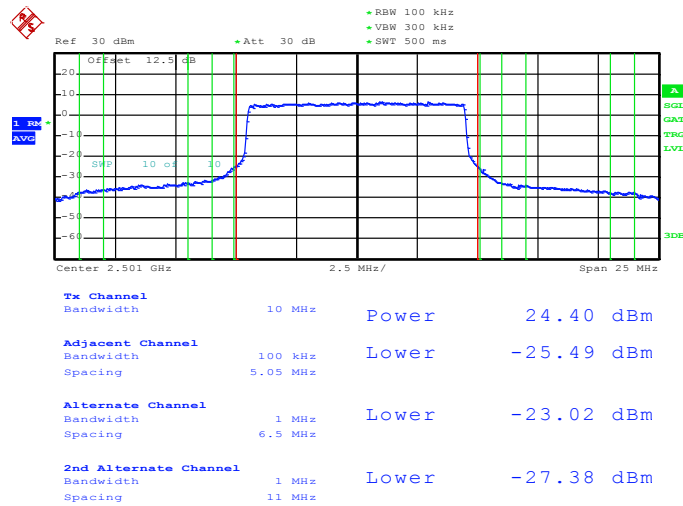

Date: 2.MAY.2012 00:02:31



Higher Band Edge Plot for QPSK-RB Size 1, RB Offset 49

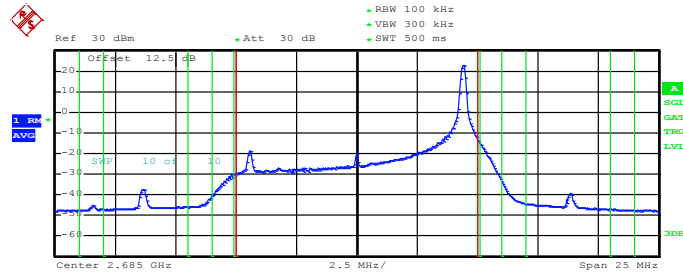

Tx Channel	Bandwidth	10 MHz	Power	25.52 dBm
Adjacent Channel	Bandwidth	100 kHz	Upper	-14.08 dBm
	Spacing	5.05 MHz		
Alternate Channel	Bandwidth	1 MHz	Upper	-29.88 dBm
	Spacing	6.5 MHz		
2nd Alternate Channel	Bandwidth	1 MHz	Upper	-37.67 dBm
	Spacing	11 MHz		

Date: 1.MAY.2012 23:11:09

Higher Band Edge Plot for QPSK-RB Size 25, RB Offset 0

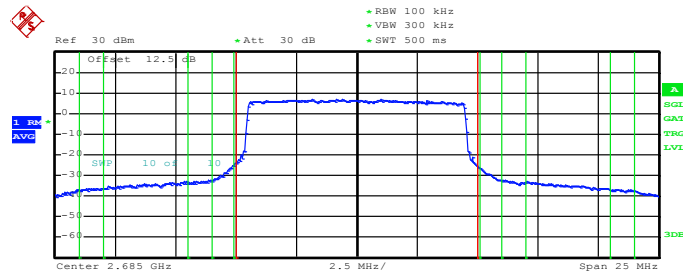

Tx Channel	Bandwidth	10 MHz	Power	25.10 dBm
Adjacent Channel	Bandwidth	100 kHz	Upper	-26.05 dBm
	Spacing	5.05 MHz		
Alternate Channel	Bandwidth	1 MHz	Upper	-23.41 dBm
	Spacing	6.5 MHz		
2nd Alternate Channel	Bandwidth	1 MHz	Upper	-27.57 dBm
	Spacing	11 MHz		

Date: 1.MAY.2012 23:09:46



Band :	LTE Band 41	Band Width	20MHz
---------------	-------------	-------------------	-------

Lower Band Edge Plot for QPSK-RB Size 1, RB Offset 0

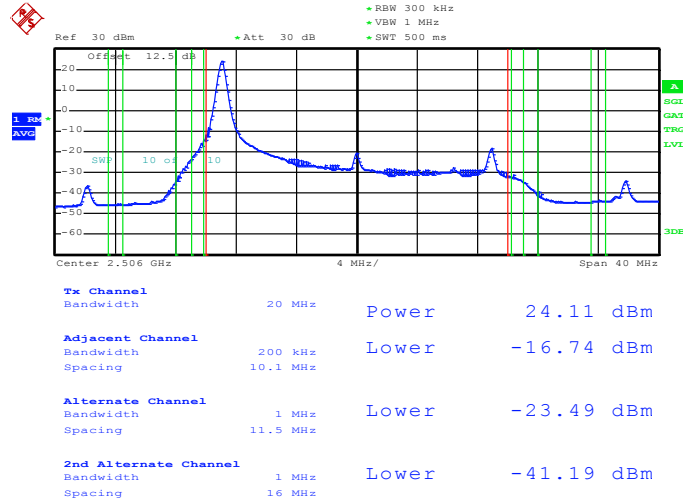

Date: 1.MAY.2012 23:51:24

Lower Band Edge Plot for QPSK-RB Size 100, RB Offset 0

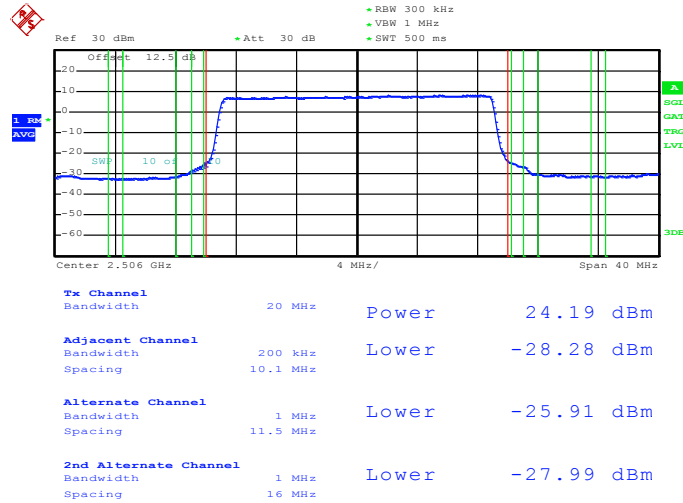

Date: 1.MAY.2012 23:38:41



Higher Band Edge Plot for QPSK-RB Size 1, RB Offset 99

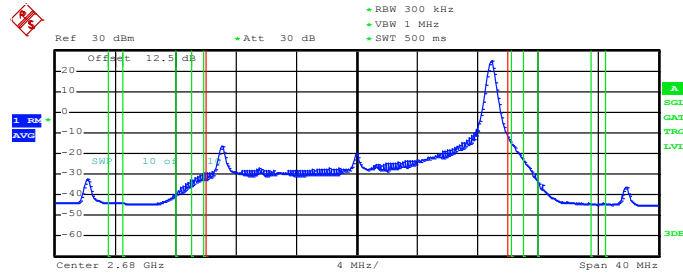

Tx Channel	Bandwidth	20 MHz	Power	25.22 dBm
Adjacent Channel	Bandwidth	200 kHz	Upper	-15.27 dBm
	Spacing	10.1 MHz		
Alternate Channel	Bandwidth	1 MHz	Upper	-22.08 dBm
	Spacing	11.5 MHz		
2nd Alternate Channel	Bandwidth	1 MHz	Upper	-40.14 dBm
	Spacing	16 MHz		

Date: 1.MAY.2012 23:27:46

Higher Band Edge Plot for QPSK-RB Size 100, RB Offset 0

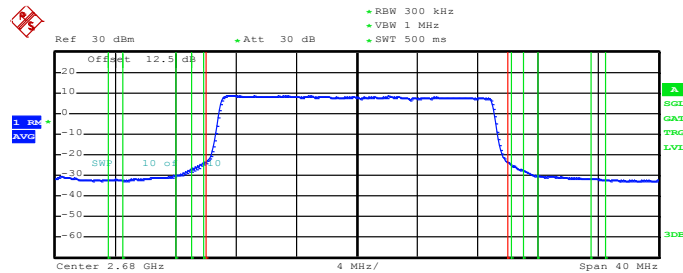

Tx Channel	Bandwidth	20 MHz	Power	24.86 dBm
Adjacent Channel	Bandwidth	200 kHz	Upper	-26.96 dBm
	Spacing	10.1 MHz		
Alternate Channel	Bandwidth	1 MHz	Upper	-24.55 dBm
	Spacing	11.5 MHz		
2nd Alternate Channel	Bandwidth	1 MHz	Upper	-27.46 dBm
	Spacing	16 MHz		

Date: 1.MAY.2012 23:24:09

3.5 Conducted Emission Measurement

3.5.1 Description of Conducted Emission Measurement

The power of any emission outside of the authorized operating frequency ranges must be lower than the transmitter power (P) by a factor of at least $43 + 10 \log (P)$ dB.

It is measured by means of a calibrated spectrum analyzer and scanned from 9 KHz up to a frequency including its 10th harmonic.

3.5.2 Measuring Instruments

See list of measuring instruments of this test report.

3.5.3 Test Procedures

1. The EUT was connected to spectrum analyzer and base station via power divider.
2. The middle channel for the highest RF power within the transmitting frequency was measured.
3. The conducted spurious emission for the whole frequency range was taken.

3.5.4 Test Setup

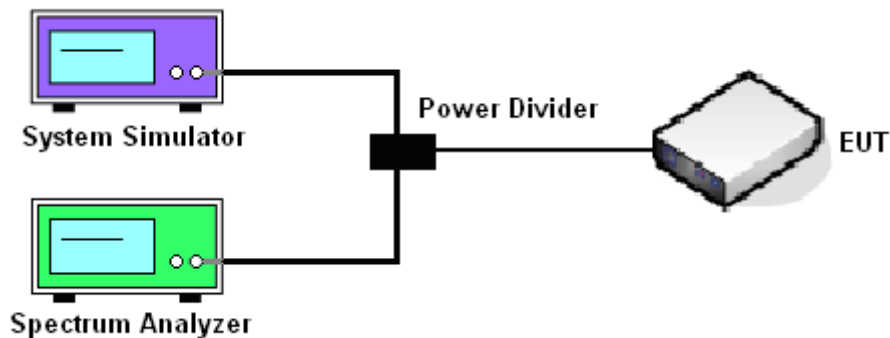



3.5.5 Test Result (Plots) of Conducted Emission

Band :	LTE Band 41	Channel :	CH39700 (Low)
Band Width	10MHz		

QPSK (RB Size 50, RB Offset 0)

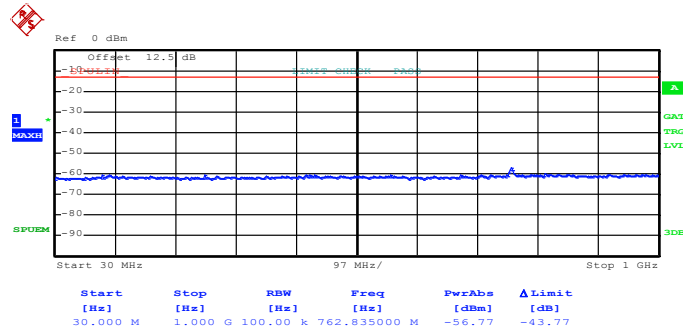

Date: 3.MAY.2012 21:20:08

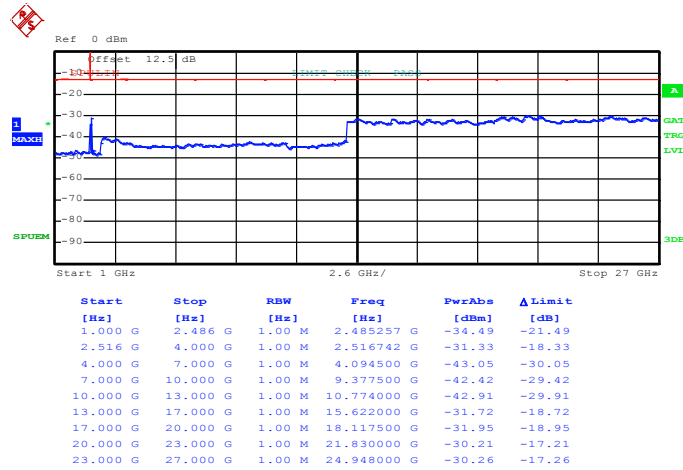

Date: 3.MAY.2012 21:41:05



Band :	LTE Band 41	Channel :	CH40620 (Middle)
Band Width	10MHz		

QPSK (RB Size 50, RB Offset 0)

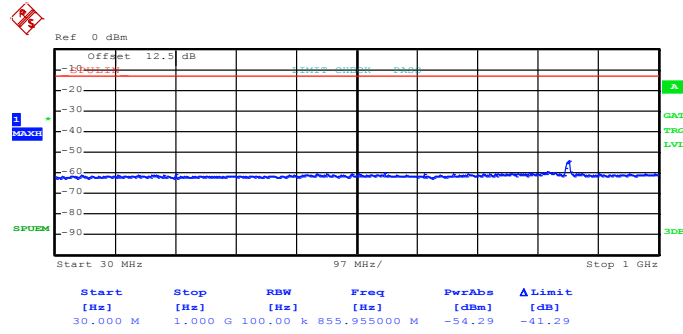

Date: 3.MAY.2012 21:49:24

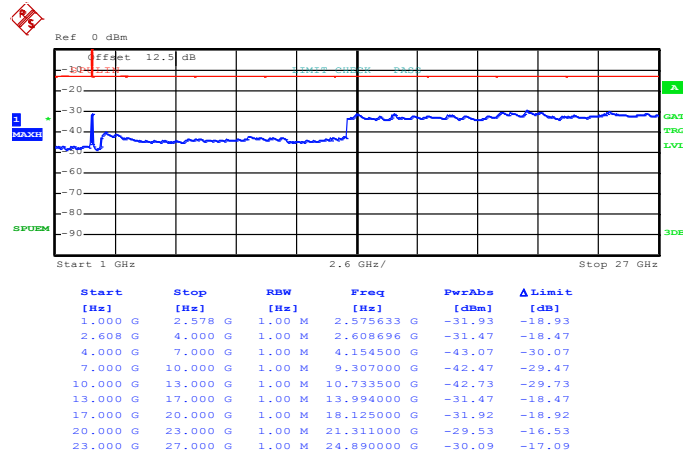

Date: 3.MAY.2012 21:47:51



Band :	LTE Band 41	Channel :	CH41540 (High)
Band Width	10MHz		

QPSK (RB Size 50, RB Offset 0)

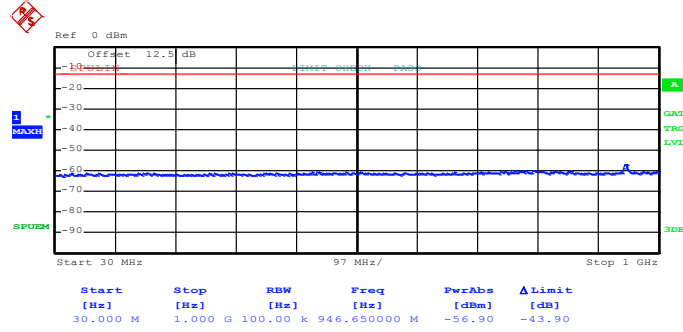

Date: 3.MAY.2012 22:07:48

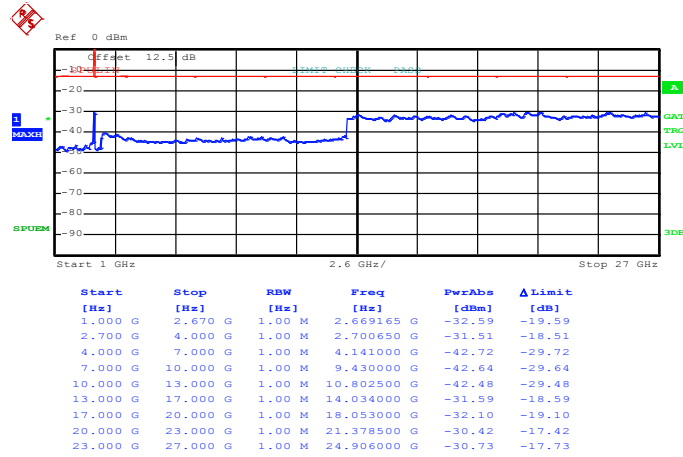

Date: 3.MAY.2012 22:09:03



Band :	LTE Band 41	Channel :	CH39750 (Low)
Band Width	20MHz		

QPSK (RB Size 100, RB Offset 0)

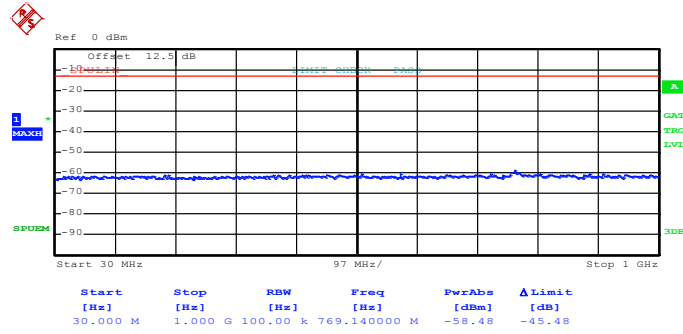

Date: 3.MAY.2012 21:27:09

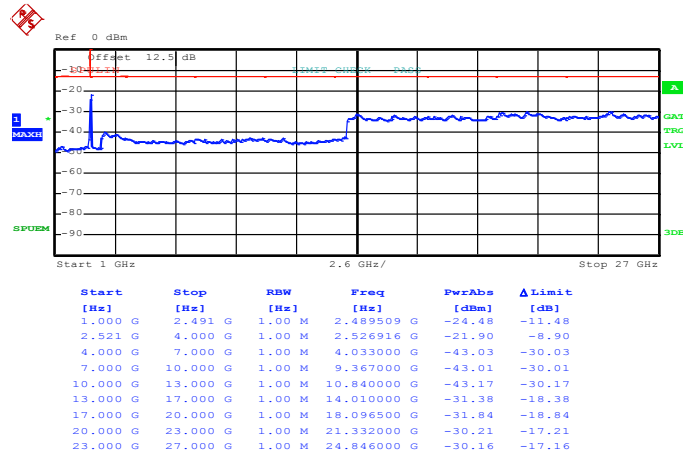

Date: 3.MAY.2012 21:37:31



Band :	LTE Band 41	Channel :	CH40620 (Middle)
Band Width	20MHz		

QPSK (RB Size 100, RB Offset 0)

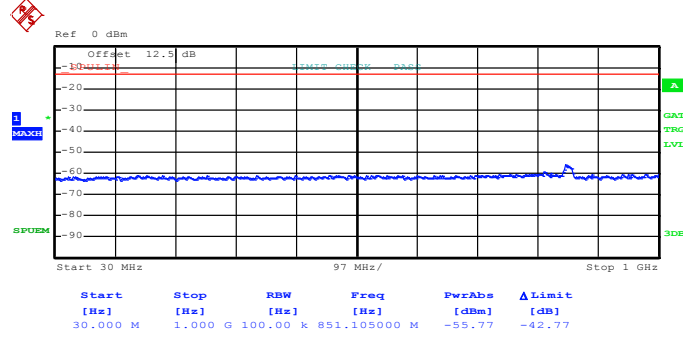

Date: 3.MAY.2012 21:52:09

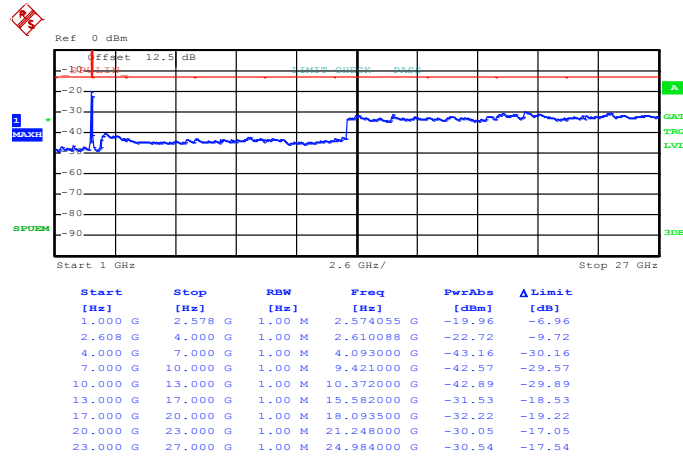

Date: 3.MAY.2012 21:56:15



Band :	LTE Band 41	Channel :	CH41490 (High)
Band Width	20MHz		

QPSK (RB Size 100, RB Offset 0)

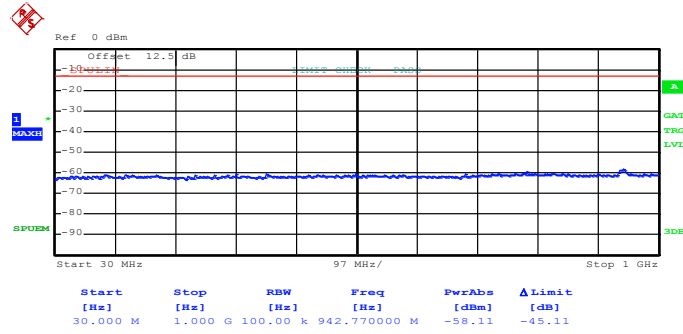

Date: 3.MAY.2012 22:02:12

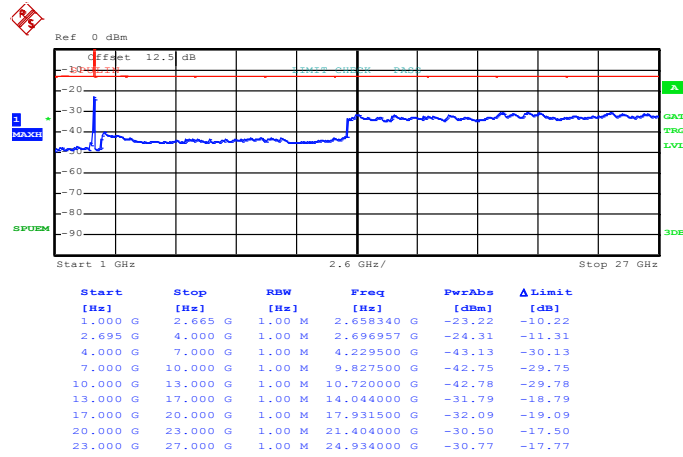

Date: 3.MAY.2012 21:59:09

3.6 Field Strength of Spurious Radiation Measurement

3.6.1 Description of Field Strength of Spurious Radiated Measurement

The radiated spurious emission was measured by substitution method according to ANSI / TIA / EIA-603-C-2004. The power of any emission outside of the authorized operating frequency ranges must be attenuated below the transmitter power (P) by a factor of at least $43 + 10 \log (P)$ dB. The spectrum is scanned from 30 MHz up to a frequency including its 10th harmonic.

3.6.2 Measuring Instruments

See list of measuring instruments of this test report.

3.6.3 Test Procedures

1. The EUT was placed on a rotatable wooden table with 0.8 meter about ground.
2. The EUT was set 3 meters from the receiving antenna, which was mounted on the antenna tower.
3. The table was rotated 360 degrees to determine the position of the highest spurious emission.
4. The height of the receiving antenna is varied between one meter and four meters to search the maximum spurious emission for both horizontal and vertical polarizations.
5. Make the measurement with the spectrum analyzer's RBW = 1MHz, VBW = 3MHz, Sweep = 500ms, Taking the record of maximum spurious emission.
6. A horn antenna was substituted in place of the EUT and was driven by a signal generator.
7. Tune the output power of signal generator to the same emission level with EUT maximum spurious emission.
8. Taking the record of output power at antenna port.
9. Repeat step 7 to step 8 for another polarization.
10. Emission level (dBm) = output power + substitution Gain.

3.6.4 Test Setup

For radiated emissions from 30MHz to 1GHz

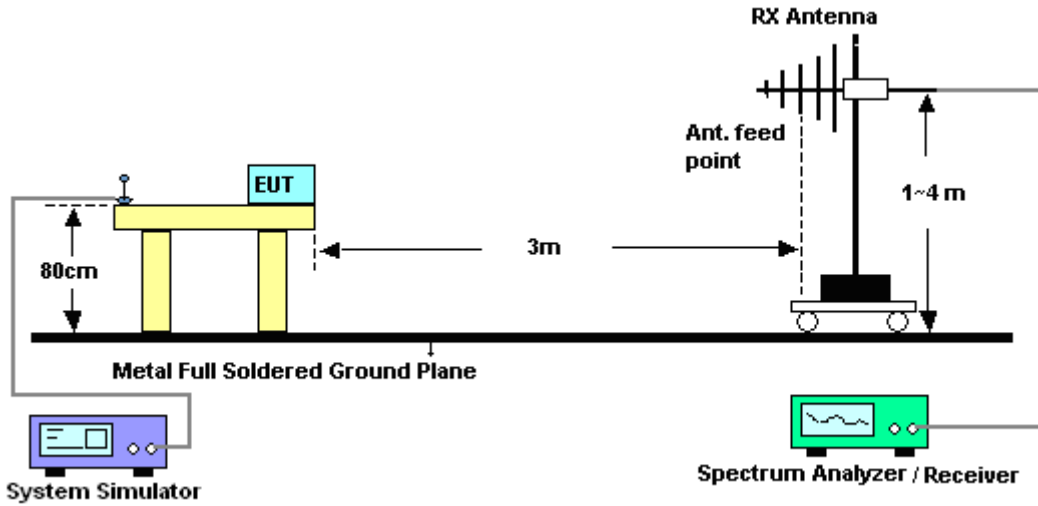

For radiated emissions above 1GHz

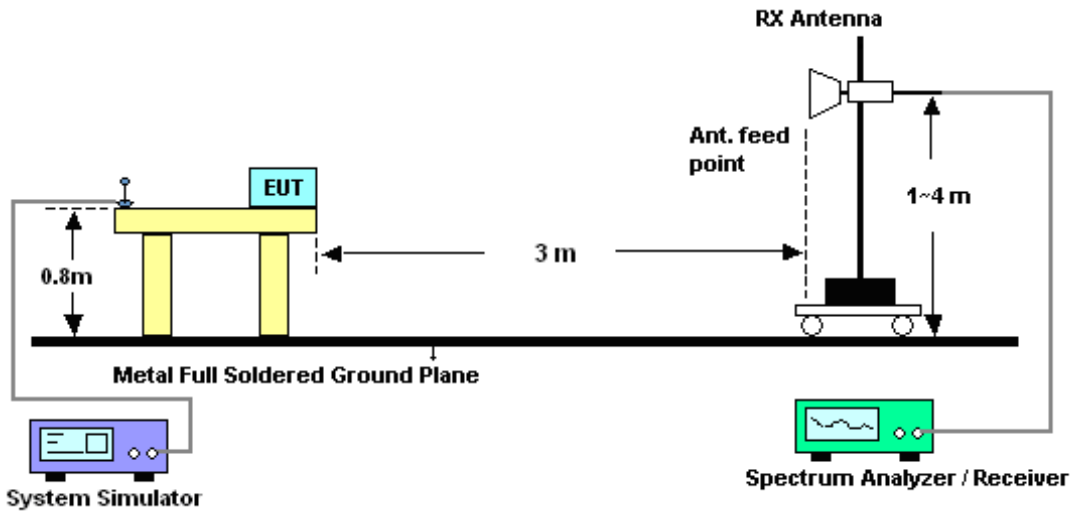

3.6.5 Test Results of Radiated Emissions (9 KHz ~ 30 MHz)

The low frequency, which started from 9 KHz to 30MHz, was pre-scanned and the result which was 20dB lower than the limit line per 15.31(o) was not reported.



3.6.6 Test Result of Field Strength of Spurious Radiated

Band :	LTE Band 41	Temperature :	23~24°C
Test Mode :	10MHZ QPSK RB Size 1	Relative Humidity :	46~47%
Test Engineer :	Kai Wang	Polarization :	Horizontal
Remark :	Spurious emissions within 30-10th harmonic were found more than 20dB below limit line.		

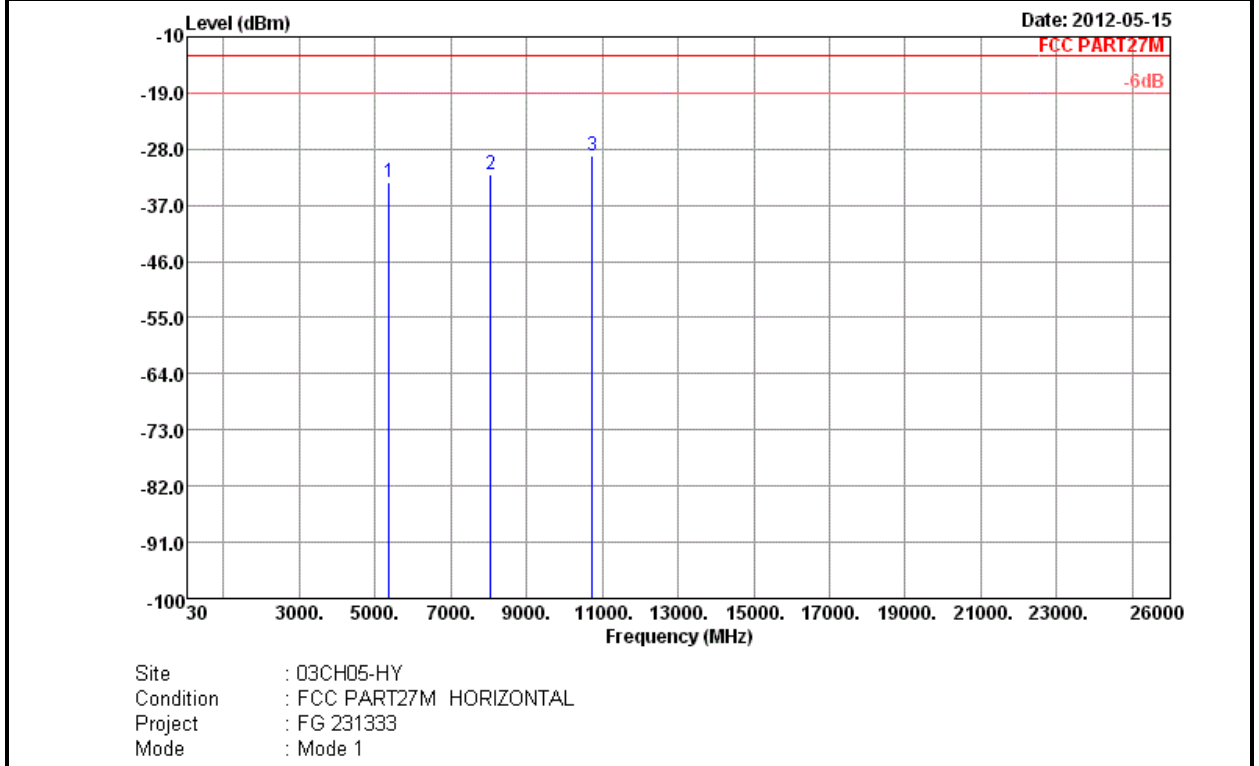

Frequency (MHz)	EIRP (dBm)	Limit (dBm)	Over Limit (dB)	SPA Reading (dBm)	S.G. Power (dBm)	TX Cable loss (dB)	TX Antenna Gain (dBi)	Polarization (H/V)	Result
5370	-33.35	-13	-20.35	-82.42	-28.42	2.42	-2.51	H	Pass
8055	-31.97	-13	-18.97	-88.26	-24.53	4.7	-2.74	H	Pass
10740	-29.14	-13	-26.14	-89.69	-22.41	6.41	-0.32	H	Pass



Band :	LTE Band 41	Temperature :	23~24°C
Test Mode :	10MHZ QPSK RB Size 1	Relative Humidity :	46~47%
Test Engineer :	Kai Wang	Polarization :	Vertical
Remark :	Spurious emissions within 30-10th harmonic were found more than 20dB below limit line.		

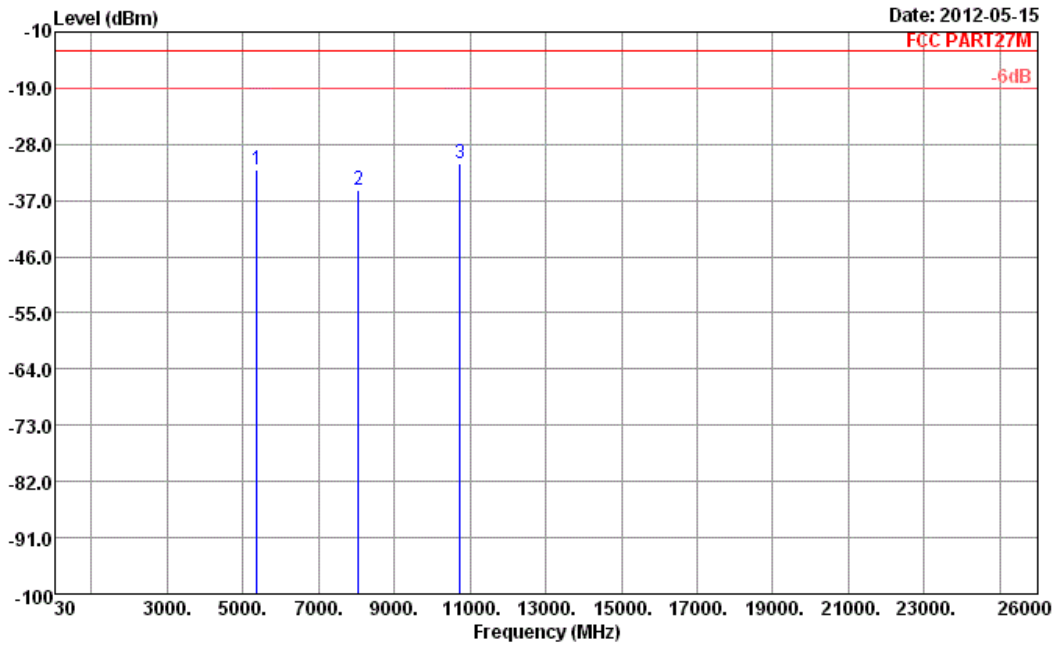

Site : 03CH05-HY
 Condition : FCC PART27M VERTICAL
 Project : FG 231333
 Mode : Mode 1

Frequency (MHz)	EIRP (dBm)	Limit (dBm)	Over Limit (dB)	SPA Reading (dBm)	S.G. Power (dBm)	TX Cable loss (dB)	TX Antenna Gain (dBi)	Polarization (H/V)	Result
5370	-32.05	-13	-19.05	-81.03	-27.12	2.42	-2.51	V	Pass
8055	-35.24	-13	-22.24	-87.84	-27.80	4.7	-2.74	V	Pass
10740	-30.98	-13	-17.98	-88.83	-24.25	6.41	-0.32	V	Pass



Band :	LTE Band 41	Temperature :	23~24°C
Test Mode :	20MHZ QPSK RB Size 1	Relative Humidity :	46~47%
Test Engineer :	Kai Wang	Polarization :	Horizontal
Remark :	Spurious emissions within 30-10th harmonic were found more than 20dB below limit line.		

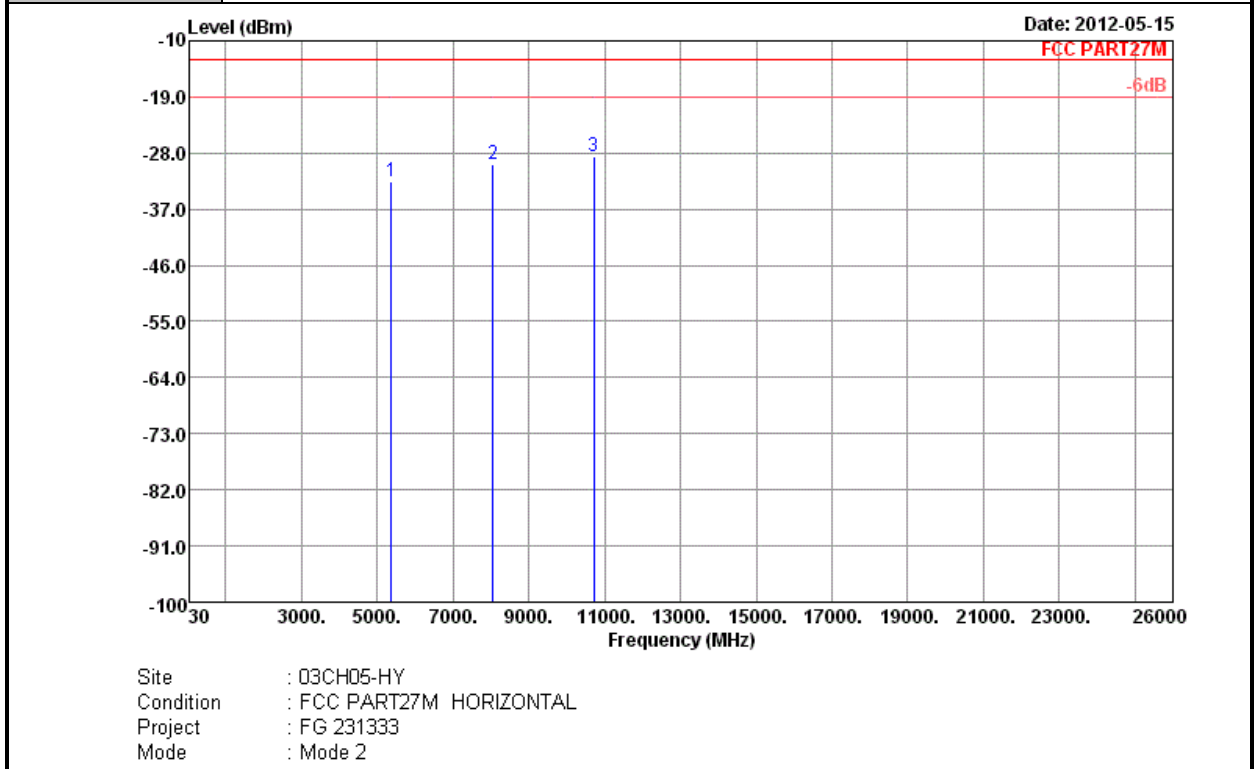

Frequency (MHz)	EIRP (dBm)	Limit (dBm)	Over Limit (dB)	SPA Reading (dBm)	S.G. Power (dBm)	TX Cable loss (dB)	TX Antenna Gain (dBi)	Polarization (H/V)	Result
5360	-32.50	-13	-19.50	-81.06	-27.61	2.4	-2.49	H	Pass
8040	-29.74	-13	-16.74	-86.65	-22.35	4.62	-2.77	H	Pass
10720	-28.56	-13	-15.56	-89.16	-21.84	6.38	-0.34	H	Pass



Band :	LTE Band 41	Temperature :	23~24°C
Test Mode :	20MHZ QPSK RB Size 1	Relative Humidity :	46~47%
Test Engineer :	Kai Wang	Polarization :	Vertical
Remark :	Spurious emissions within 30-10th harmonic were found more than 20dB below limit line.		

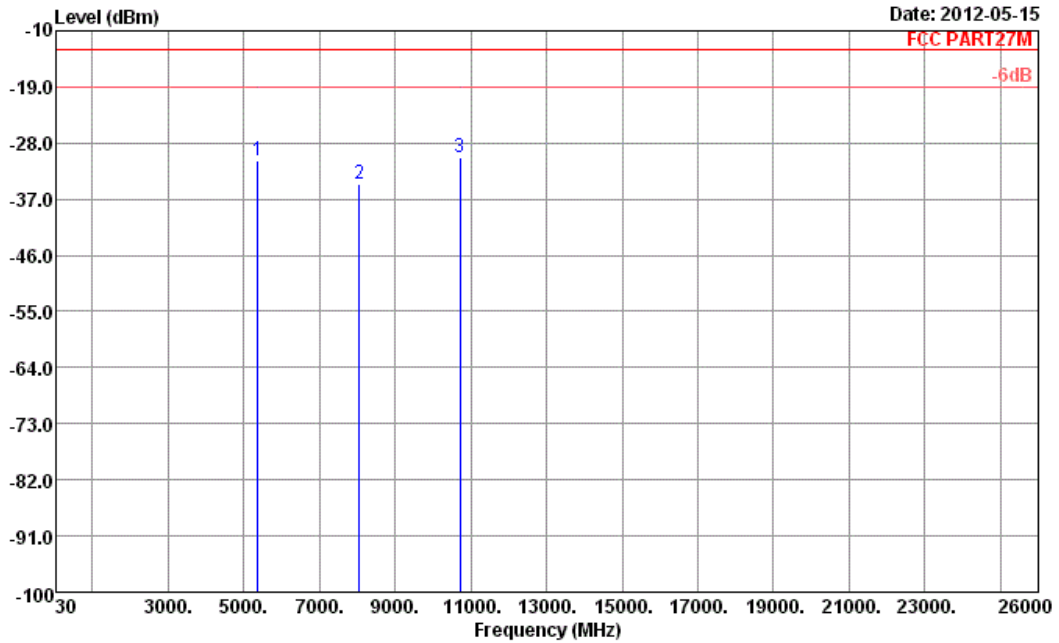

Site : 03CH05-HY
 Condition : FCC PART27M VERTICAL
 Project : FG 231333
 Mode : Mode 2

Frequency (MHz)	EIRP (dBm)	Limit (dBm)	Over Limit (dB)	SPA Reading (dBm)	S.G. Power (dBm)	TX Cable loss (dB)	TX Antenna Gain (dBi)	Polarization (H/V)	Result
5360	-30.90	-13	-17.90	-79.82	-26.01	2.4	-2.49	V	Pass
8040	-34.51	-13	-21.51	-86.3	-27.12	4.62	-2.77	V	Pass
10720	-30.26	-13	-17.26	-88.63	-23.54	6.38	-0.34	V	Pass

3.7 Frequency Stability Measurement

3.7.1 Description of Frequency Stability Measurement

The frequency stability shall be measured by variation of ambient temperature and variation of primary supply voltage to ensure that the fundamental emission stays within the authorized frequency block. The frequency stability of the transmitter shall be maintained within $\pm 0.00025\%$ ($\pm 2.5\text{ppm}$) of the center frequency.

3.7.2 Measuring Instruments

See list of measuring instruments of this test report.

3.7.3 Test Procedures for Temperature Variation

1. The EUT was set up in the thermal chamber and connected with the base station.
2. With power OFF, the temperature was decreased to -30°C and the EUT was stabilized before testing. Power was applied and the maximum change in frequency was recorded within one minute.
3. With power OFF, the temperature was raised in 10°C step up to 50°C . The EUT was stabilized at each step for at least half an hour. Power was applied and the maximum frequency change was recorded within one minute.
4. If the EUT can not be turned on at -30°C , the testing lowest temperature will be raised in 10°C step until the EUT can be turned on.

3.7.4 Test Procedures for Voltage Variation

1. The EUT was placed in a temperature chamber at $25\pm 5^{\circ}\text{C}$ and connected with the base station.
2. The power supply voltage to the EUT was varied from 85% to 115% of the nominal value measured at the input to the EUT.
3. The variation in frequency was measured for the worst case.

3.7.5 Test Setup

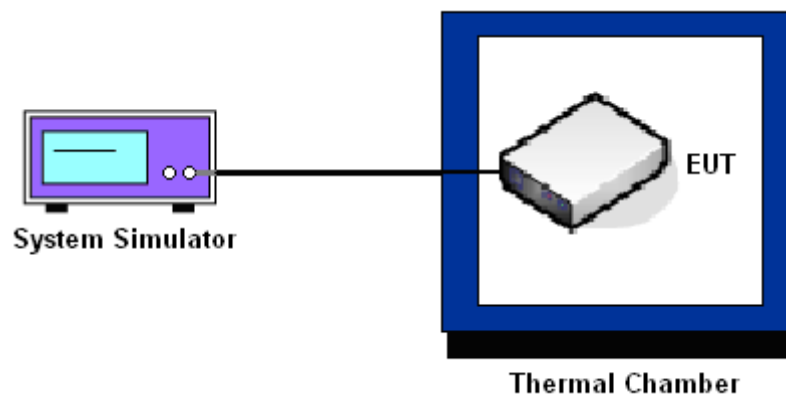

3.7.6 Test Result of Temperature Variation

Band :	LTE Band 41			Limit (ppm) :	2.5
Temperature (°C)	BW 10MHz		BW 20MHz		Result
	Freq. Dev. (Hz)	Deviation (ppm)	Freq. Dev. (Hz)	Deviation (ppm)	
-30	-22.1	-0.031	-22.6	-0.032	PASS
-20	-16.9	-0.024	-11.7	-0.017	
-10	-11.8	-0.017	-15.4	-0.022	
0	-13.7	-0.019	-12.4	-0.017	
10	-14.4	-0.020	-12.5	-0.018	
20	-18.5	-0.026	-19.3	-0.027	
30	-17.0	-0.024	-13.7	-0.019	
40	-12.6	-0.018	-14.8	-0.021	
50	-9.3	-0.013	-13.3	-0.019	
60	-15.3	-0.021	-12.6	-0.018	

Note: The manufacturer declared that the EUT could work properly between temperatures -30°C~60°C.

3.7.7 Test Result of Voltage Variation

Band	Bandwidth	Voltage (Volt)	Freq. Dev. (Hz)	Deviation (ppm)	Limit (ppm)	Result
LTE Band 41	10M	Normal	-13.4	-0.019	2.5	PASS
		42	-17.2	-0.024		
		57	-10.9	-0.015		
	20M	Normal	16.2	0.023		
		42	-14.9	-0.021		
		57	15.0	0.021		

Remark:

1. Normal Voltage = 48V.
2. The manufacturer declared that the EUT could work properly between voltage 42V ~ 57V.



4 List of Measuring Equipments

Instrument	Manufacturer	Model No.	Serial No.	Characteristics	Calibration Date	Test Date	Due Date	Remark
System Simulator	R&S	CMU200	117995	N/A	Jul. 28, 2011	Apr. 02, 2012~ May 03, 2012	Jul. 27, 2012	Conducted (TH02-HY)
Spectrum Analyzer	R&S	FSP40	100055	9kHz~40GHz	Jun. 13, 2011	Apr. 02, 2012~ May 03, 2012	Jun. 12, 2012	Conducted (TH02-HY)
Thermal Chamber	Ten Billion	TTH-D35P	TBN-930701	N/A	Jul. 27, 2011	Apr. 02, 2012~ May 03, 2012	Jul. 26, 2012	Conducted (TH02-HY)
Spectrum Analyzer	R&S	ESU26	100390	20Hz ~ 26.5GHz	Dec. 22, 2011	May 10, 2012~ May 15, 2012	Dec. 21, 2012	Radiation (03CH05-HY)
Bilog Antenna	SCHAFFNER	CBL6111C	2725	30MHz ~ 2GHz	Oct. 22, 2011	May 10, 2012~ May 15, 2012	Oct. 21, 2012	Radiation (03CH05-HY)
Turn Table	HD	Deis HD 2000	420/611	0 ~ 360 degree	N/A	May 10, 2012~ May 15, 2012	N/A	Radiation (03CH05-HY)
Antenna Mast	HD	MA 240	240/666	1 m ~ 4 m	N/A	May 10, 2012~ May 15, 2012	N/A	Radiation (03CH05-HY)
Horn Antenna	ESCO	3117	66584	1GHz ~ 18GHz	Aug. 04, 2011	May 10, 2012~ May 15, 2012	Aug. 03, 2012	Radiation (03CH05-HY)
Pre Amplifier	COM-POWER	PA-103A	161075	10Hz ~ 1000MHz Gain:32dB	Feb. 27, 2012	May 10, 2012~ May 15, 2012	Feb. 26, 2013	Radiation (03CH05-HY)
Pre Amplifier	MITEQ	AMF-7D-001 01800-30-10	159087	1GHz~18GHz	Feb. 27, 2012	May 10, 2012~ May 15, 2012	Feb. 26, 2013	Radiation (03CH05-HY)
Pre Amplifier	Agilent	8449B	3008A01917	1GHz~26.5GHz	Aug. 30, 2011	May 10, 2012~ May 15, 2012	Aug. 29, 2012	Radiation (03CH05-HY)
Wideband Radio Communication Tester	R&S	CMW500	113998	N/A	Sep. 16, 2011	May 10, 2012~ May 15, 2012	Sep. 15, 2012	Radiation (03CH05-HY)

5 Uncertainty of Evaluation

Uncertainty of Radiated Emission Measurement (30 MHz ~ 1000 MHz)

Contribution	Uncertainty of X_i		$u(X_i)$
	dB	Probability Distribution	
Receiver Reading	0.41	Normal (k=2)	0.21
Antenna Factor Calibration	0.83	Normal (k=2)	0.42
Cable Loss Calibration	0.25	Normal (k=2)	0.13
Pre-Amplifier Gain Calibration	0.27	Normal (k=2)	0.14
RCV/SPA Specification	2.50	Rectangular	0.72
Antenna Factor Interpolation for Frequency	1.00	Rectangular	0.29
Site Imperfection	1.43	Rectangular	0.83
Mismatch	+0.39 / -0.41	U-Shape	0.28
Combined Standard Uncertainty $Uc(y)$	1.27		
Measuring Uncertainty for a Level of Confidence of 95% ($U = 2Uc(y)$)	2.54		

Uncertainty of Radiated Emission Measurement (1 GHz ~ 40 GHz)

Contribution	Uncertainty of X_i		$u(X_i)$	C_i	$C_i * u(X_i)$
	dB	Probability Distribution			
Receiver Reading	± 0.10	Normal (k=2)	0.10	1	0.10
Antenna Factor Calibration	± 1.70	Normal (k=2)	0.85	1	0.85
Cable Loss Calibration	± 0.50	Normal (k=2)	0.25	1	0.25
Receiver Correction	± 2.00	Rectangular	1.15	1	1.15
Antenna Factor Directional	± 1.50	Rectangular	0.87	1	0.87
Site Imperfection	± 2.80	Triangular	1.14	1	1.14
Mismatch Receiver VSWR $\Gamma_1 = 0.197$ Antenna VSWR $\Gamma_2 = 0.194$ Uncertainty = $20\text{Log}(1-\Gamma_1*\Gamma_2)$	+0.34 / -0.35	U-Shape	0.244	1	0.244
Combined Standard Uncertainty $Uc(y)$	2.36				
Measuring Uncertainty for a Level of Confidence of 95% ($U = 2Uc(y)$)	4.72				



Appendix A. Photographs of EUT

Please refer to Sporton report number EP231333 as below.