



# SPORTON International Inc.

No. 52, Hwa Ya 1st Rd., Hwa Ya Technology Park, Kwei-Shan Hsiang, Tao Yuan Hsien, Taiwan, R.O.C.  
Ph: 886-3-327-3456 / FAX: 886-3-327-0973 / www.sporton.com.tw

## FCC RADIO TEST REPORT

Applicant's company	MitraStar Technology Corporation
Applicant Address	No. 6, Innovation Rd II, Science-Based Industrial, Hsin-Chu, Taiwan
FCC ID	ZMYHGW-500BNA-QC
Manufacturer's company (1)	MitraStar Technology Corporation
Manufacturer Address	No. 6, Innovation Rd II, Hsinchu Science Park, Hsinchu 30076, Taiwan
Manufacturer's company (2)	WuXi MitraStar Technology Co. Ltd
Manufacturer Address	60#-E, Minshan Road, Wuxi New district Jangsu, P.R.C.

Product Name	Wireless Extender
Brand Name	ARRIS
Model No.	VAP4402
Test Rule Part(s)	47 CFR FCC Part 15 Subpart E § 15.407
Test Freq. Range	5150 ~ 5350MHz / 5470 ~ 5725MHz / 5725 ~ 5850 MHz
Received Date	Apr. 20, 2015
Final Test Date	Nov. 15, 2017
Submission Type	Class II Change

### Statement

**Test result included is for the IEEE 802.11n and IEEE 802.11a/ac of the product.**

The test result in this report refers exclusively to the presented test model / sample.

Without written approval of SPORTON International Inc., the test report shall not be reproduced except in full.

The measurements and test results shown in this test report were made in accordance with the procedures and found in compliance with the limit given in **ANSI C63.10-2013, 47 CFR FCC Part 15 Subpart E, KDB789033 D02 v02, KDB662911 D01 v02r01, KDB644545 D03 v01, ET Docket No. 13-49; FCC 16-24.**

The test equipment used to perform the test is calibrated and traceable to NML/ROC.



## Table of Contents

<b>1. VERIFICATION OF COMPLIANCE</b> .....	<b>1</b>
<b>2. SUMMARY OF THE TEST RESULT</b> .....	<b>2</b>
<b>3. GENERAL INFORMATION</b> .....	<b>3</b>
3.1. Product Details.....	3
3.2. Accessories.....	4
3.3. Table for Filed Antenna.....	5
3.4. Table for Carrier Frequencies .....	8
3.5. Table for Test Modes .....	9
3.6. Table for Testing Locations.....	10
3.7. Table for Class II Change .....	10
3.8. Table for Supporting Units .....	11
3.9. EUT Operation during Test .....	11
3.10. Test Configurations .....	12
<b>4. TEST RESULT</b> .....	<b>14</b>
4.1. AC Power Line Conducted Emissions Measurement.....	14
4.2. Radiated Emissions Measurement .....	18
4.3. Antenna Requirements .....	24
<b>5. LIST OF MEASURING EQUIPMENTS</b> .....	<b>25</b>
<b>6. MEASUREMENT UNCERTAINTY</b> .....	<b>26</b>
<b>APPENDIX A. TEST PHOTOS</b> .....	<b>A1 ~ A3</b>
<b>PHOTOGRAPHS OF EUT V01</b>	



## History of This Test Report

REPORT NO.	VERSION	DESCRIPTION	ISSUED DATE
FR550536-07AB	Rev. 01	Initial issue of report	Dec. 15, 2017

## 1. VERIFICATION OF COMPLIANCE

Product Name : Wireless Extender  
Brand Name : ARRIS  
Model No. : VAP4402  
Applicant : MitraStar Technology Corporation  
Test Rule Part(s) : 47 CFR FCC Part 15 Subpart E § 15.407

Sporton International as requested by the applicant to evaluate the EMC performance of the product sample received on Apr. 20, 2015 would like to declare that the tested sample has been evaluated and found to be in compliance with the tested rule parts. The data recorded as well as the test configuration specified is true and accurate for showing the sample's EMC nature.



Cliff Chang

SPORTON INTERNATIONAL INC.

## 2. SUMMARY OF THE TEST RESULT

Applied Standard: 47 CFR FCC Part 15 Subpart E			
Part	Rule Section	Description of Test	Result
4.1	15.207	AC Power Line Conducted Emissions	Complies
4.2	15.407(b)	Radiated Emissions	Complies
4.3	15.203	Antenna Requirements	Complies

### 3. GENERAL INFORMATION

#### 3.1. Product Details

Items	Description
Product Type	WLAN (4TX, 4RX)
Radio Type	Intentional Transceiver
Power Type	From power adapter
Modulation	IEEE 802.11a: OFDM IEEE 802.11n/ac: see the below table
Data Modulation	IEEE 802.11a/n: OFDM (BPSK / QPSK / 16QAM / 64QAM) IEEE 802.11ac: OFDM (BPSK / QPSK / 16QAM / 64QAM / 256QAM)
Data Rate (Mbps)	IEEE 802.11a: OFDM (6/9/12/18/24/36/48/54) IEEE 802.11n/ac: see the below table
Frequency Range	5150 ~ 5350MHz / 5470 ~ 5725MHz / 5725 ~ 5850 MHz
Channel Number	25 for 20MHz bandwidth ; 12 for 40MHz bandwidth 6 for 80MHz bandwidth
Carrier Frequencies	Please refer to section 3.4
Antenna	Please refer to section 3.3

Items	Description	
Communication Mode	<input checked="" type="checkbox"/> IP Based (Load Based)	<input type="checkbox"/> Frame Based
TPC Function	<input checked="" type="checkbox"/> With TPC	<input type="checkbox"/> Without TPC
Weather Band (5600~5650MHz)	<input checked="" type="checkbox"/> With 5600~5650MHz	<input type="checkbox"/> Without 5600~5650MHz
Beamforming Function	<input checked="" type="checkbox"/> With beamforming for 802.11n/ac in 5GHz.	<input type="checkbox"/> Without beamforming

#### Antenna and Bandwidth

Antenna	Four (TX)		
	20 MHz	40 MHz	80 MHz
IEEE 802.11a	V	X	X
IEEE 802.11n	V	V	X
IEEE 802.11ac	V	V	V

**IEEE 11n/ac Spec.**

Protocol	Number of Transmit Chains (NTX)	Data Rate / MCS
802.11n (HT20)	4	MCS 0-31
802.11n (HT40)	4	MCS 0-31
802.11ac (VHT20)	4	MCS 0-9/Nss1-4
802.11ac (VHT40)	4	MCS 0-9/Nss1-4
802.11ac (VHT80)	4	MCS 0-9/Nss1-4

Note 1: IEEE Std. 802.11n modulation consists of HT20 and HT40 (HT: High Throughput).  
Then EUT supports HT20 and HT40.

Note 2: IEEE Std. 802.11ac modulation consists of VHT20, VHT40, VHT80 and VHT160 (VHT: Very High Throughput). Then EUT supports VHT20, VHT40 and VHT80.

Note 3: Modulation modes consist of below configuration:  
HT20/HT40: IEEE 802.11n, VHT20/VHT40/VHT80: IEEE 802.11ac

**3.2. Accessories**

Power	Brand	Model	Rating
Adapter	APD	WB-18Q12FU	Input: 100~120V, 50-60Hz, 0.6A Max. Output: 12V, 1.5A
Other			
LAN Cable*1: 1.5 meter, non-shielded, w/o ferrite core			

### 3.3. Table for Filed Antenna

Ant.	Brand	P/N	Antenna Type	Connector
1	-	-	Printed Antenna	N/A
2	CING XIN	A176-137LB-140IPCX016-1	PCB Antenna	I-PEX
3	-	-	Printed Antenna	N/A
4	-	-	Printed Antenna	N/A
5	-	-	Printed Antenna	N/A
6	-	-	Printed Antenna	N/A

2.4GHz Antenna Gain (dBi)		
Frequency	Ant. 1	Ant. 2
2412 MHz	2.40	6.15
2422 MHz	2.40	6.15
2437 MHz	2.43	5.90
2452 MHz	2.43	5.90
2462 MHz	2.01	5.48



5GHz Antenna Gain (dBi)				
Frequency	Ant. 3	Ant. 4	Ant. 5	Ant. 6
5180 MHz	2.84	3.94	2.78	2.16
5190 MHz	3.07	4.09	2.82	2.27
5200 MHz	2.67	4.07	2.73	2.4
5210 MHz	3.01	4.00	2.68	2.47
5230 MHz	3.03	4.02	2.81	2.87
5240 MHz	3.16	3.79	2.81	2.9
5260 MHz	3.23	3.67	3.00	3.08
5270 MHz	3.03	3.47	3.05	2.72
5290 MHz	3.12	3.26	2.94	2.83
5300 MHz	3.06	3.09	3.06	2.83
5310 MHz	2.97	2.99	3.04	2.90
5320 MHz	3.17	2.99	3.19	2.82
5500 MHz	2.46	3.47	2.94	3.14
5510 MHz	2.28	3.65	2.79	3.18
5530 MHz	2.48	3.74	2.90	3.38
5550 MHz	2.32	3.61	2.76	3.48
5580 MHz	2.19	3.26	2.5	3.31
5610 MHz	2.19	3.26	2.50	3.31
5670 MHz	2.78	2.98	3.41	3.28
5690 MHz	2.78	2.98	3.41	3.28
5700 MHz	2.66	3.15	3.49	3.26
5710 MHz	2.71	3.02	3.54	3.34
5720 MHz	2.52	2.84	3.46	3.42
5745 MHz	2.71	3.17	3.52	3.46
5755 MHz	2.7	3.07	3.29	3.39
5775 MHz	2.59	2.93	3.19	3.35
5785 MHz	2.75	2.88	3.31	3.41
5795 MHz	2.66	2.93	3.2	3.58
5825 MHz	2.38	2.86	3.15	3.54

Note: The EUT has six antennas.

**For 2.4GHz function:**

**For IEEE 802.11b/g/n mode (1TX/1RX):**

Only Ant.1 can be used as transmitting/receiving antenna.

**For IEEE 802.11n mode (2TX/2RX):**

Ant.1 and Ant.2 can be used as transmitting/receiving antenna.

Ant.1 and Ant.2 could transmit/receive simultaneously.

**For 5GHz function:**

**For IEEE 802.11a/n/ac mode (4TX/4RX):**

Ant.3, Ant.4, Ant.5 and Ant.6 can be used as transmitting/receiving antenna.

Ant.3, Ant.4, Ant.5 and Ant.6 could transmit/receive simultaneously.

For 2.4GHz Ant.1

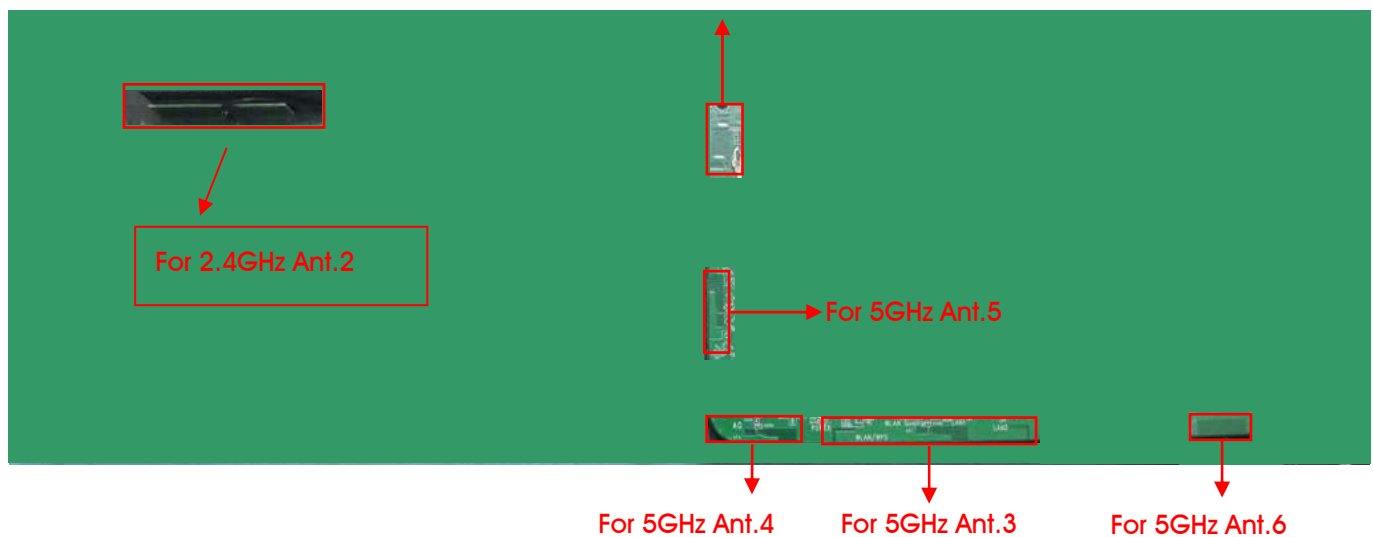

### 3.4. Table for Carrier Frequencies

There are three bandwidth systems.

For 20MHz bandwidth systems, use Channel 36, 40, 44, 48, 52, 56, 60, 64, 100, 104, 108, 112, 116, 120, 124, 128, 132, 136, 140, 144, 149, 153, 157, 161, 165.

For 40MHz bandwidth systems, use Channel 38, 46, 54, 62, 102, 110, 118, 126, 134, 142, 151, 159.

For 80MHz bandwidth systems, use Channel 42, 58, 106, 122, 138, 155.

Frequency Band	Channel No.	Frequency	Channel No.	Frequency
5150~5250 MHz Band 1	36	5180 MHz	44	5220 MHz
	38	5190 MHz	46	5230 MHz
	40	5200 MHz	48	5240 MHz
	42	5210 MHz	-	-
5250~5350 MHz Band 2	52	5260 MHz	60	5300 MHz
	54	5270 MHz	62	5310 MHz
	56	5280 MHz	64	5320 MHz
	58	5290 MHz	-	-
5470~5725 MHz Band 3	100	5500 MHz	124	5620 MHz
	102	5510 MHz	126	5630 MHz
	104	5520 MHz	128	5640 MHz
	106	5530 MHz	132	5660 MHz
	108	5540 MHz	134	5670 MHz
	110	5550 MHz	136	5680 MHz
	112	5560 MHz	138	5690 MHz
	116	5580 MHz	140	5700 MHz
	118	5590 MHz	142	5710 MHz
	120	5600 MHz	144	5720 MHz
5725~5850 MHz Band 4	149	5745 MHz	157	5785 MHz
	151	5755 MHz	159	5795 MHz
	153	5765 MHz	161	5805 MHz
	155	5775 MHz	165	5825 MHz

### 3.5. Table for Test Modes

Preliminary tests were performed in different data rate to find the worst radiated emission. The data rate shown in the table below is the worst-case rate with respect to the specific test item. The following table is a list of the test modes shown in this test report.

Test Items	Mode	Data Rate	Channel	Antenna
AC Power Conducted Emission	Normal Link	-	-	-
Radiated Emission Below 1GHz	Normal Link	-	-	-

Note 1: The EUT can only be used at standing position.

Note 2: All the specification of test configurations and test modes were based on customer's request.

Note 3: The Master Mode supports both AP and Extender mode, only AP mode was tested and recorded in this test report.

The following test modes were performed for all tests:

**For Conducted Emission test:**

Mode 1. Normal Link - AP Mode

Mode 2. Normal Link - STA Mode

Mode 1 is the worst case, so it was selected to record in this test report.

**For Radiated Emission test (Below 1GHz):**

Mode 1. Normal Link - AP Mode - Y axis

Mode 2. Normal Link - STA Mode - Y axis

Mode 1 is the worst case, so it was selected to record in this test report.

### 3.6. Table for Testing Locations

Test Site Location					
Address:	No.8, Lane 724, Bo-ai St., Jhubei City, Hsinchu County 302, Taiwan, R.O.C.				
TEL:	886-3-656-9065				
FAX:	886-3-656-9085				
Test Site No.	Site Category	Location	FCC Designation No.	IC File No.	VCCI Reg. No
03CH01-CB	SAC	Hsin Chu	TW0006	IC 4086D	-
CO01-CB	Conduction	Hsin Chu	TW0006	IC 4086D	-

Open Area Test Site (OATS); Semi Anechoic Chamber (SAC).

### 3.7. Table for Class II Change

This product is an extension of original one reported under Sporton project number: FR550536AB

Below is the table for the change of the product with respect to the original one.

Modifications	Performance Checking
1. Changing the equipment name to Wireless Extender from WiFi Gateway. 2. Changing the brand name to ARRIS from Pace. 3. Changing the model name to VAP4402 from AW525. 4. Adding the Extender Mode.	It's no need to re-test.
5. Changing AC Adapter (Brand: APD, Model: WB-18Q12FU) 6. Changing the housing. 7. Changing the position of the WPS button. 8. Changing the DDR to 256MB 9. Taking out three LEDs. 10. Change LAN Cable.	1. AC Power Line Conducted Emissions Measurement 2. Radiated Emissions Measurement (below 1GHz)

### 3.8. Table for Supporting Units

For Test Site No: 03CH01-CB (Below 1GHz)

Support Unit	Brand	Model	FCC ID
NB*2	DELL	E4300	DoC
NB	APPLE	Mac Book	DoC
Wireless Extender	ARRIS	VAP4402	ZMYHGW-500BNA-QC

For Test Site No: CO01-CB

Support Unit	Brand	Model	FCC ID
NB*3	DELL	E6430	DoC
Wireless Extender	ARRIS	VAP4402	ZMYHGW-500BNA-QC

### 3.9. EUT Operation during Test

During the test, the EUT operation to normal function.

### 3.10. Test Configurations

#### 3.10.1. AC Power Line Conduction Emissions Test Configuration

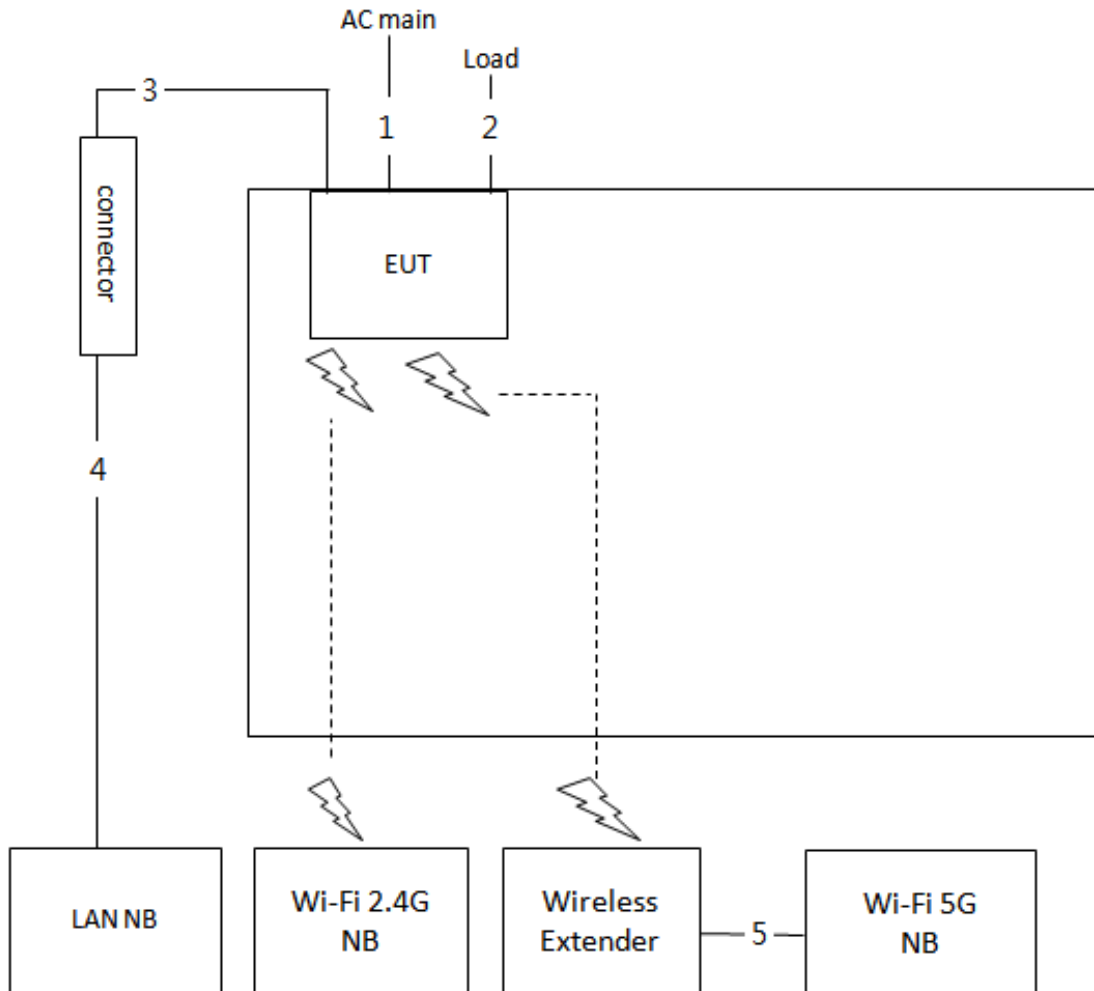

Item	Connection	Shielded	Length
1	Power cable	No	1.5m
2	RJ-45 cable	No	1.5m
3	LAN cable	No	1.5m
4	RJ-45 cable	No	10m
5	RJ-45 cable	No	1.5m

### 3.10.2. Radiation Emissions Test Configuration

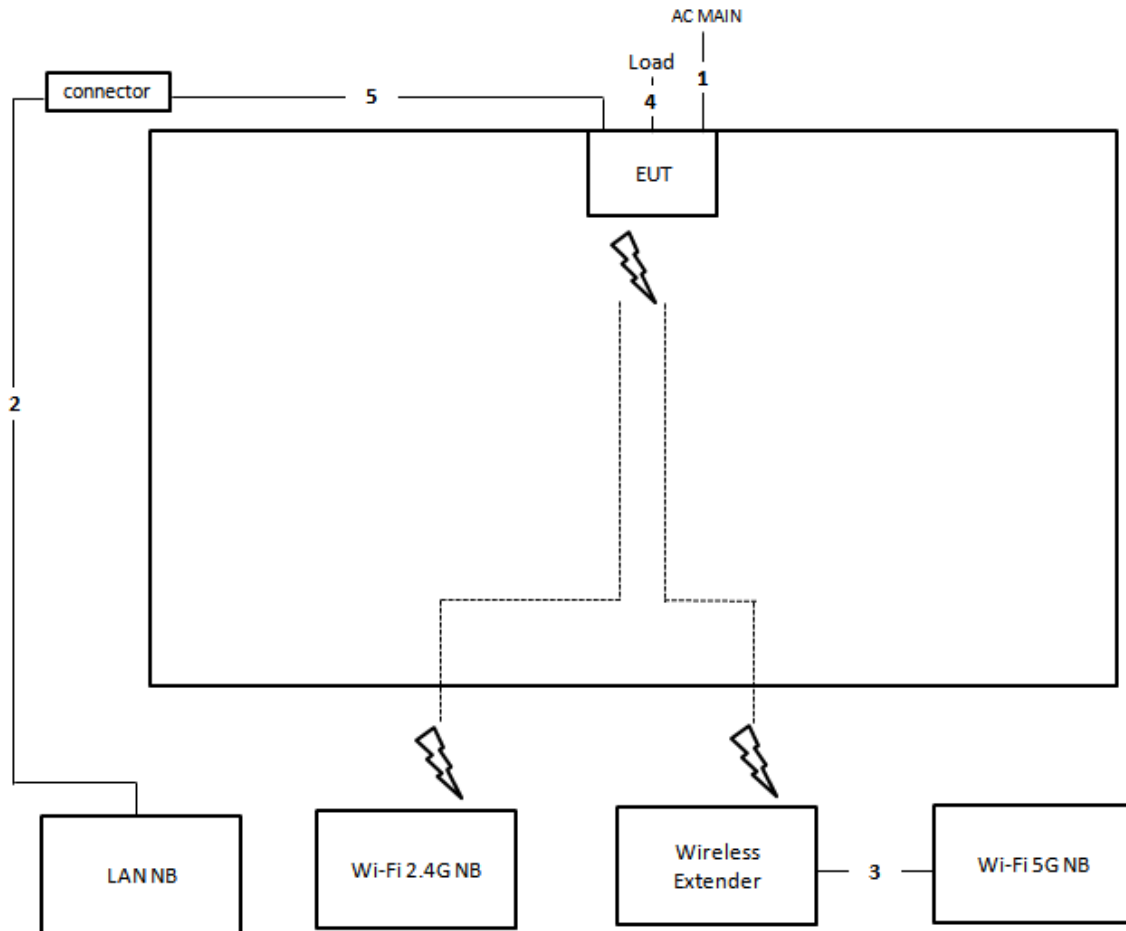

Item	Connection	Shielded	Length
1	Power cable	No	1.5m
2	RJ-45 cable	No	10m
3	RJ-45 cable	No	1.5m
4	RJ-45 cable	No	1.5m
5	LAN cable	No	1.5m



## 4. TEST RESULT

### 4.1. AC Power Line Conducted Emissions Measurement

#### 4.1.1. Limit

For this product that is designed to connect to the AC power line, the radio frequency voltage that is conducted back onto the AC power line on any frequency or frequencies within the band 150 kHz to 30 MHz shall not exceed below limits table.

Frequency (MHz)	QP Limit (dBuV)	AV Limit (dBuV)
0.15~0.5	66~56	56~46
0.5~5	56	46
5~30	60	50

#### 4.1.2. Measuring Instruments and Setting

Please refer to section 5 of equipments list in this report. The following table is the setting of the receiver.

Receiver Parameters	Setting
Attenuation	10 dB
Start Frequency	0.15 MHz
Stop Frequency	30 MHz
IF Bandwidth	9 kHz

#### 4.1.3. Test Procedures

1. Configure the EUT according to ANSI C63.10. The EUT or host of EUT has to be placed 0.4 meter far from the conducting wall of the shielding room and at least 80 centimeters from any other grounded conducting surface.
2. Connect EUT or host of EUT to the power mains through a line impedance stabilization network (LISN).
3. All the support units are connected to the other LISNs. The LISN should provide 50uH/50ohms coupling impedance.
4. The frequency range from 150 kHz to 30 MHz was searched.
5. Set the test-receiver system to Peak Detect Function and Specified Bandwidth with Maximum Hold Mode.
6. The measurement has to be done between each power line and ground at the power terminal.

#### 4.1.4. Test Setup Layout

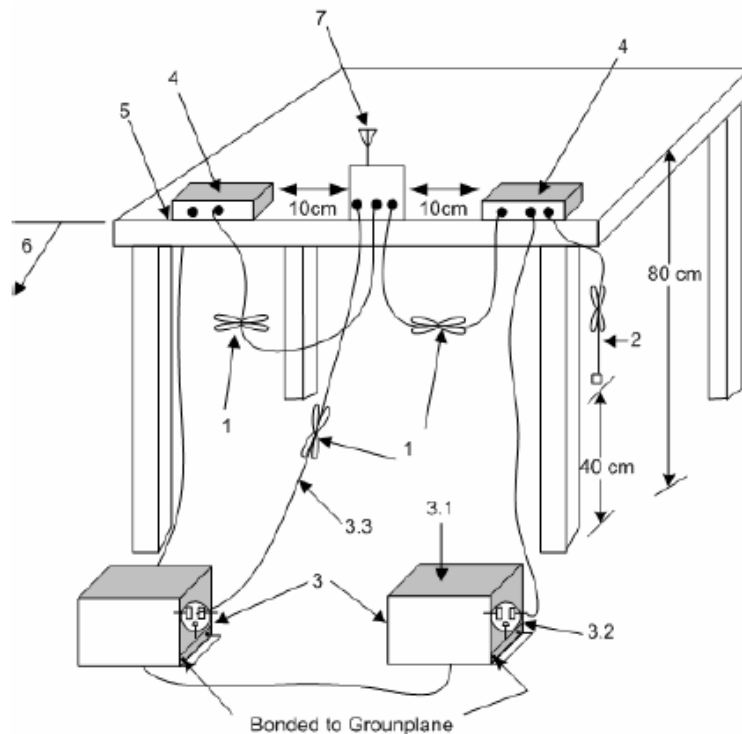

- 1—Interconnecting cables that hang closer than 40 cm to the ground plane shall be folded back and forth in the center forming a bundle 30 cm to 40 cm long.
- 2—The I/O cables that are not connected to an accessory shall be bundled in the center. The end of the cable may be terminated, if required, using the correct terminating impedance. The overall length shall not exceed 1 m.
- 3—EUT connected to one LISN. Unused LISN measuring port connectors shall be terminated in 50  $\Omega$  loads. LISN may be placed on top of, or immediately beneath, reference ground plane.
- 3.1—All other equipment powered from additional LISN(s).
- 3.2—A multiple-outlet strip may be used for multiple power cords of non-EUT equipment.
- 3.3—LISN at least 80 cm from nearest part of EUT chassis.
- 4—Non-EUT components of EUT system being tested.
- 5—Rear of EUT, including peripherals, shall all be aligned and flush with edge of tabletop.
- 6—Edge of tabletop shall be 40 cm removed from a vertical conducting plane that is bonded to the ground plane.
- 7—Antenna can be integral or detachable. If detachable, then the antenna shall be attached for this test.

#### 4.1.5. Test Deviation

There is no deviation with the original standard.

#### 4.1.6. EUT Operation during Test

The EUT was placed on the test table and programmed in normal function.

4.1.7. Results of AC Power Line Conducted Emissions Measurement

Temperature	25°C	Humidity	65%
Test Engineer	Tony Chang	Phase	Line
Configuration	Normal Link	Test Mode	Mode 1

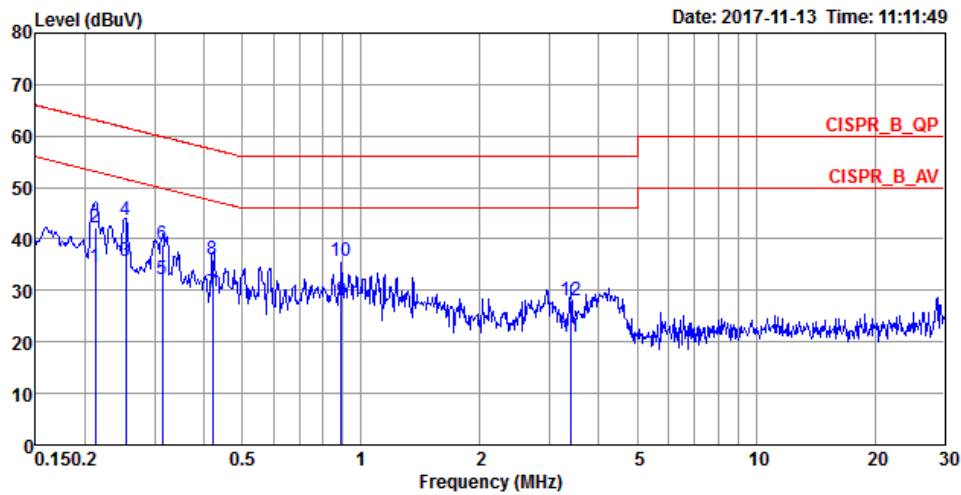

	Freq	Level	Over Limit	Limit Line	Read Level	LISN Factor	Cable Loss	Remark	Pol/Phase
	MHz	dBuV	dB	dBuV	dBuV	dB	dB		
1	0.2128	34.50	-18.60	53.10	24.46	9.92	0.12	Average	LINE
2	0.2128	42.16	-20.94	63.10	32.12	9.92	0.12	QP	LINE
3	0.2535	35.59	-16.05	51.64	25.58	9.92	0.09	Average	LINE
4	0.2535	43.81	-17.83	61.64	33.80	9.92	0.09	QP	LINE
5	0.3133	32.15	-17.73	49.88	22.17	9.93	0.05	Average	LINE
6	0.3133	38.92	-20.96	59.88	28.94	9.93	0.05	QP	LINE
7	0.4215	29.40	-18.02	47.42	19.43	9.95	0.02	Average	LINE
8	0.4215	36.15	-21.27	57.42	26.18	9.95	0.02	QP	LINE
9	0.8897	27.99	-18.01	46.00	17.86	9.96	0.17	Average	LINE
10	0.8897	35.58	-20.42	56.00	25.45	9.96	0.17	QP	LINE
11	3.3814	21.03	-24.97	46.00	10.93	9.97	0.13	Average	LINE
12	3.3814	27.91	-28.09	56.00	17.81	9.97	0.13	QP	LINE

Temperature	25°C	Humidity	65%
Test Engineer	Tony Chang	Phase	Neutral
Configuration	Normal Link	Test Mode	Mode 1

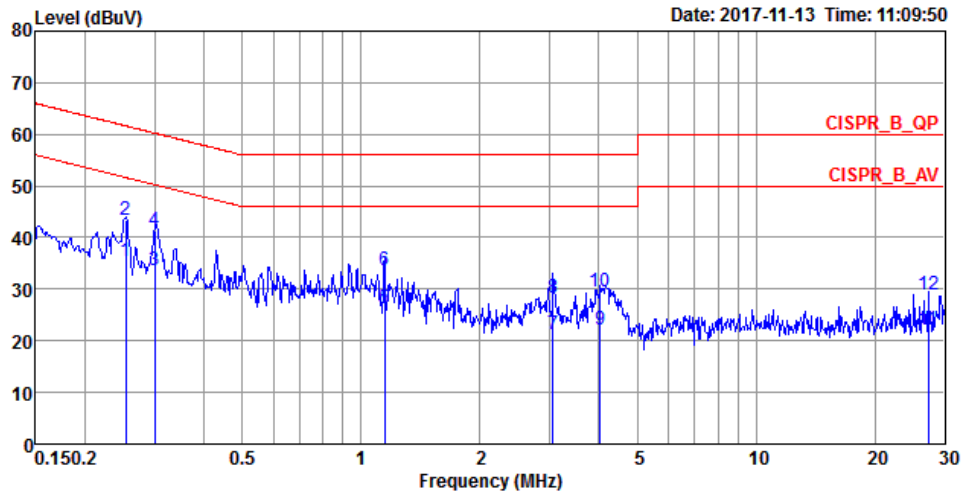

	Freq	Level	Over Limit	Limit Line	Read Level	LISN Factor	Cable Loss	Remark	Pol/Phase
	MHz	dBuV	dB	dBuV	dBuV	dB	dB		
1	0.2535	35.49	-16.15	51.64	25.32	10.08	0.09	Average	NEUTRAL
2	0.2535	43.47	-18.17	61.64	33.30	10.08	0.09	QP	NEUTRAL
3	0.3003	33.57	-16.67	50.24	23.36	10.15	0.06	Average	NEUTRAL
4	0.3003	41.36	-18.88	60.24	31.15	10.15	0.06	QP	NEUTRAL
5	1.1473	26.38	-19.62	46.00	16.16	10.03	0.19	Average	NEUTRAL
6	1.1473	33.60	-22.40	56.00	23.38	10.03	0.19	QP	NEUTRAL
7	3.0576	21.39	-24.61	46.00	11.29	9.96	0.14	Average	NEUTRAL
8	3.0576	28.27	-27.73	56.00	18.17	9.96	0.14	QP	NEUTRAL
9	4.0275	22.06	-23.94	46.00	12.00	9.96	0.10	Average	NEUTRAL
10	4.0275	29.43	-26.57	56.00	19.37	9.96	0.10	QP	NEUTRAL
11	27.2711	22.07	-27.93	50.00	11.29	10.51	0.27	Average	NEUTRAL
12	27.2711	28.89	-31.11	60.00	18.11	10.51	0.27	QP	NEUTRAL

Note:

Level = Read Level + LISN Factor + Cable Loss.

## 4.2. Radiated Emissions Measurement

### 4.2.1. Limit

For transmitters operating in the 5.15-5.35 GHz band: all emissions outside of the 5.15-5.35 GHz band shall not exceed an e.i.r.p. of  $-27$  dBm/MHz.

For transmitters operating in the 5.470-5.725 GHz band: all emissions outside of the 5.47-5.725 GHz band shall not exceed an e.i.r.p. of  $-27$  dBm/MHz.

For transmitters operating in the 5.725-5.85 GHz band: all emissions shall be limited to a level of  $-27$  dBm/MHz at 75 MHz or more above or below the band edge increasing linearly to 10 dBm/MHz at 25 MHz above or below the band edge, and from 25 MHz above or below the band edge increasing linearly to a level of 15.6 dBm/MHz at 5 MHz above or below the band edge, and from 5 MHz above or below the band edge increasing linearly to a level of 27 dBm/MHz at the band edge.

In addition, In case the emission fall within the restricted band specified on 15.205(a), then the 15.209(a) limit in the table below has to be followed.

Frequencies (MHz)	Field Strength (micovolts/meter)	Measurement Distance (meters)
0.009~0.490	2400/F(kHz)	300
0.490~1.705	24000/F(kHz)	30
1.705~30.0	30	30
30~88	100	3
88~216	150	3
216~960	200	3
Above 960	500	3

### 4.2.2. Measuring Instruments and Setting

Please refer to section 5 of equipments list in this report. The following table is the setting of spectrum analyzer and receiver.

Spectrum Parameter	Setting
Attenuation	Auto
Start Frequency	1000 MHz
Stop Frequency	40 GHz
RBW / VBW (Emission in restricted band)	1 MHz / 3MHz for Peak, 1 MHz / 1/T for Average
RBW / VBW (Emission in non-restricted band)	1 MHz / 3MHz for peak

Receiver Parameter	Setting
Attenuation	Auto
Start ~ Stop Frequency	9kHz~150kHz / RBW 200Hz for QP
Start ~ Stop Frequency	150kHz~30MHz / RBW 9kHz for QP
Start ~ Stop Frequency	30MHz~1000MHz / RBW 120kHz for QP

#### 4.2.3. Test Procedures

1. Configure the EUT according to ANSI C63.10. The EUT was placed on the top of the turntable 1.5 meter above ground. The phase center of the receiving antenna mounted on the top of a height-variable antenna tower was placed 1m & 3m far away from the turntable.
2. Power on the EUT and all the supporting units. The turntable was rotated by 360 degrees to determine the position of the highest radiation.
3. The height of the broadband receiving antenna was varied between one meter and four meters above ground to find the maximum emissions field strength of both horizontal and vertical polarization.
4. For each suspected emissions, the antenna tower was scan (from 1 M to 4 M) and then the turntable was rotated (from 0 degree to 360 degrees) to find the maximum reading.
5. Set the test-receiver system to Peak or CISPR quasi-peak Detect Function with specified bandwidth under Maximum Hold Mode.
6. For emissions above 1GHz, use 1MHz VBW and 3MHz RBW for peak reading. Then 1MHz RBW and 1/T VBW for average reading in spectrum analyzer.
7. If the emissions level of the EUT in peak mode was 3 dB lower than the average limit specified, then testing will be stopped and peak values of EUT will be reported, otherwise, the emissions which do not have 3 dB margin will be repeated one by one using the quasi-peak method for below 1GHz.
8. For testing above 1GHz, the emissions level of the EUT in peak mode was lower than average limit (that means the emissions level in peak mode also complies with the limit in average mode), then testing will be stopped and peak values of EUT will be reported, otherwise, the emissions will be measured in average mode again and reported.
9. In case the emission is lower than 30MHz, loop antenna has to be used for measurement and the recorded data should be QP measured by receiver. High – Low scan is not required in this case.

#### 4.2.4. Test Setup Layout

For Radiated Emissions: 9kHz ~30MHz

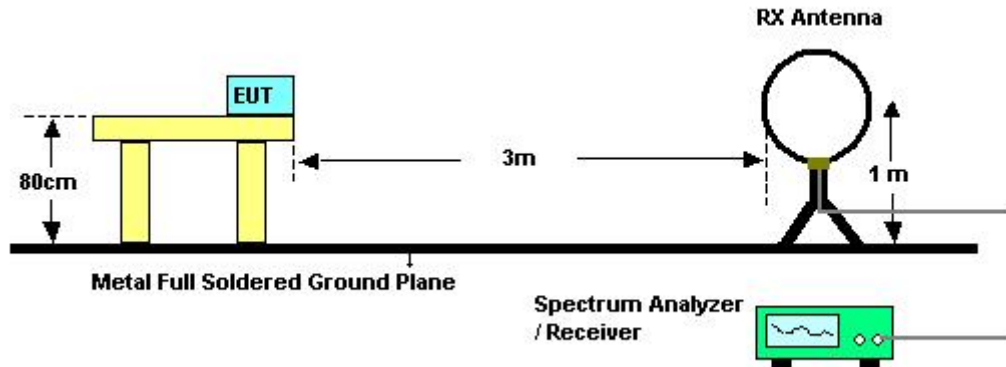

For Radiated Emissions: 30MHz~1GHz

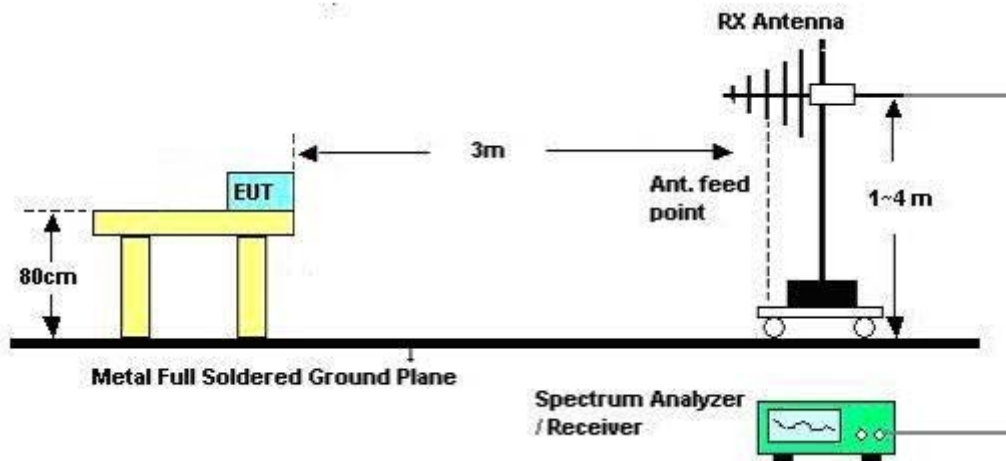

#### 4.2.5. Test Deviation

There is no deviation with the original standard.

#### 4.2.6. EUT Operation during Test

The EUT was programmed to be in continuously transmitting mode.

#### 4.2.7. Results of Radiated Emissions (9kHz~30MHz)

<b>Temperature</b>	24.1°C	<b>Humidity</b>	64%
<b>Test Engineer</b>	DK Chang & Zero Chen & Nyle Chang	<b>Configurations</b>	Normal Link
<b>Test Date</b>	Nov. 15, 2017	<b>Test Mode</b>	Mode 1

<b>Freq. (MHz)</b>	<b>Level (dBuV)</b>	<b>Over Limit (dB)</b>	<b>Limit Line (dBuV)</b>	<b>Remark</b>
-	-	-	-	See Note

**Note:**

The amplitude of spurious emissions that are attenuated by more than 20dB below the permissible value has no need to be reported.

Distance extrapolation factor =  $40 \log(\text{specific distance} / \text{test distance})$  (dB);

Limit line = specific limits (dBuV) + distance extrapolation factor.



4.2.8. Results of Radiated Emissions (30MHz~1GHz)

Temperature	24.1°C	Humidity	64%
Test Engineer	DK Chang & Zero Chen & Nyle Chang	Configurations	Normal Link
Test Mode	Mode 1		

Horizontal

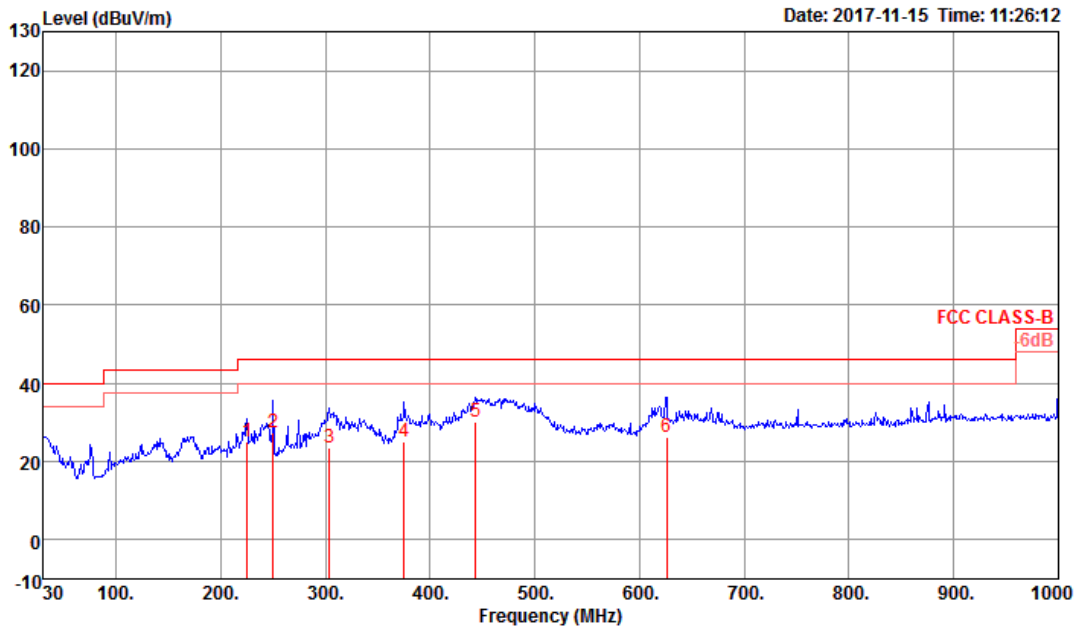

	Freq	Level	Limit	Over	Read	CableAntenna	Preamp	A/Pos	T/Pos	Remark	Pol/Phase
	MHz	dBuV/m	dBuV/m	dB	dBuV	dB	dB/m	dB	cm	deg	
1	224.97	25.01	46.00	-20.99	37.87	2.18	16.82	31.86	104	333 QP	HORIZONTAL
2	250.19	27.53	46.00	-18.47	38.15	2.38	18.90	31.90	121	34 QP	HORIZONTAL
3	303.54	23.54	46.00	-22.46	33.17	2.54	19.80	31.97	142	203 QP	HORIZONTAL
4	375.32	25.11	46.00	-20.89	33.03	2.22	21.88	32.02	191	221 QP	HORIZONTAL
5	443.22	30.22	46.00	-15.78	36.72	2.76	22.85	32.11	107	266 QP	HORIZONTAL
6	625.58	26.43	46.00	-19.57	30.75	2.76	25.26	32.34	131	119 QP	HORIZONTAL

**Vertical**

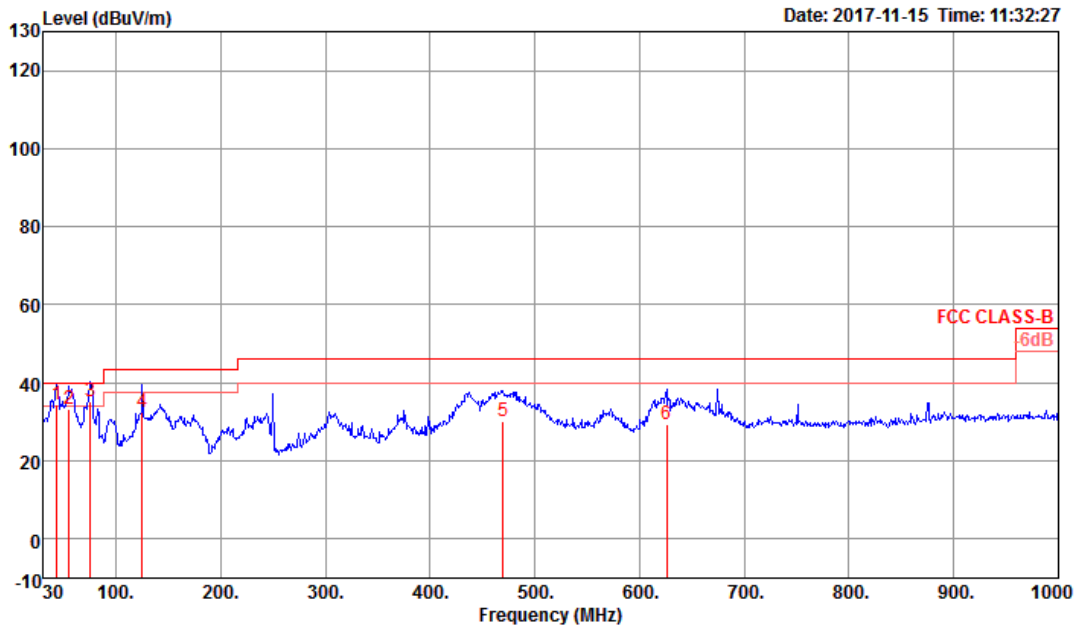

	Freq	Level	Limit	Over	Read	CableAntenna	Preamp	A/Pos	T/Pos	Remark	Pol/Phase
	MHz	dBuV/m	dBuV/m	dB	dBuV	dB	dB/m	dB	cm	deg	
1	43.58	34.54	40.00	-5.46	46.95	1.32	17.92	31.65	102	107 QP	VERTICAL
2	55.22	33.28	40.00	-6.72	49.84	1.30	13.86	31.72	105	205 QP	VERTICAL
3	75.59	35.36	40.00	-4.64	53.07	0.82	13.26	31.79	100	147 QP	VERTICAL
4	125.06	32.37	43.50	-11.13	44.40	1.15	18.65	31.83	150	211 QP	VERTICAL
5	469.41	30.15	46.00	-15.85	36.21	2.82	23.26	32.14	126	36 QP	VERTICAL
6	625.58	29.21	46.00	-16.79	33.53	2.76	25.26	32.34	110	357 QP	VERTICAL

**Note:**

The amplitude of spurious emissions which are attenuated by more than 20 dB below the permissible value has no need to be reported.

Emission level (dBuV/m) = 20 log Emission level (uV/m).

Corrected Reading: Antenna Factor + Cable Loss + Read Level - Preamp Factor = Level.

### **4.3. Antenna Requirements**

#### **4.3.1. Limit**

Except for special regulations, the Low-power Radio-frequency Devices must not be equipped with any jacket for installing an antenna with extension cable. An intentional radiator shall be designed to ensure that no antenna other than that furnished by the responsible party shall be used with the device. The use of a permanently attached antenna or of an antenna that uses a unique coupling to the intentional radiator shall be considered sufficient to comply with the provisions of this Section. The manufacturer may design the unit so that the user can replace a broken antenna, but the use of a standard antenna jack or electrical connector is prohibited. Further, this requirement does not apply to intentional radiators that must be professionally installed.

#### **4.3.2. Antenna Connector Construction**

Please refer to section 3.3 in this test report; antenna connector complied with the requirements.

## 5. LIST OF MEASURING EQUIPMENTS

Instrument	Manufacturer	Model No.	Serial No.	Characteristics	Calibration Date	Calibration Due Date	Remark
EMI Receiver	Agilent	N9038A	My52260123	9kHz~8.45GHz	Jan. 23, 2017	Jan. 22, 2018	Conduction (CO01-CB)
LISN	F.C.C.	FCC-LISN-50-16-2	04083	150kHz~ 100MHz	Dec. 14, 2016	Dec. 13, 2017	Conduction (CO01-CB)
LISN	Schwarzbeck	NSLK 8127	8127647	9kHz~30MHz	Dec. 21, 2016	Dec. 20, 2017	Conduction (CO01-CB)
COND Cable	Woken	Cable	01	150kHz ~ 30MHz	May 23, 2017	May 22, 2018	Conduction (CO01-CB)
Software	Audix	E3	6.120210n	-	N.C.R.	N.C.R.	Conduction (CO01-CB)
EMI Receiver	Agilent	N9038A	My52260123	9kHz~8.45GHz	Jan. 23, 2017	Jan. 22, 2018	Conduction (CO01-CB)
BILOG ANTENNA with 6dB Attenuator	TESEQ & EMCI	CBL6112D & N-6-06	37880 & AT-N0609	20MHz ~ 2GHz	Aug. 30, 2017	Aug. 29, 2018	Radiation (03CH01-CB)
Pre-Amplifier	EMCI	EMC330N	980332	20MHz~3GHz	May 02, 2017	May 01, 2018	Radiation (03CH01-CB)
Loop Antenna	Teseq	HLA 6120	24155	9kHz - 30 MHz	Mar. 16, 2016*	Mar. 15, 2018*	Radiation (03CH01-CB)
Spectrum Analyzer	R&S	FSP40	100056	9kHz~40GHz	Nov. 22, 2016	Nov. 21, 2017	Radiation (03CH01-CB)
EMI Test	R&S	ESCS	100355	9kHz~2.75GHz	May 06, 2017	May 05, 2018	Radiation (03CH01-CB)
RF Cable-low	Woken	Low Cable-16+17	N/A	30 MHz~1 GHz	Oct. 11, 2017	Oct. 10, 2018	Radiation (03CH01-CB)
Test Software	Audix	E3	6.2009-10-7	N/A	N/A	N/A	Radiation (03CH01-CB)

Note: Calibration Interval of instruments listed above is one year.

“\*” Calibration Interval of instruments listed above is two years.

NCR means Non-Calibration required.

## 6. MEASUREMENT UNCERTAINTY

Test Items	Uncertainty	Remark
Conducted Emission (150kHz ~ 30MHz)	3.2 dB	Confidence levels of 95%
Radiated Emission (30MHz ~ 1,000MHz)	3.6 dB	Confidence levels of 95%