



FCC TEST REPORT

REPORT NO.: RF110317E07A

MODEL NO.: HES-209M2W

FCC ID: ZMYHES209M2W

RECEIVED: Mar. 17, 2011

TESTED: Apr. 07 to 13, 2011

ISSUED: Sep. 14, 2011

APPLICANT: MitraStar Technology Corporation

ADDRESS: No. 6, Innovation Road II, Hsinchu Science Park,
Hsinchu 300, Taiwan (R.O.C.)

ISSUED BY: Bureau Veritas Consumer Products Services (H.K.)
Ltd., Taoyuan Branch Hsin Chu Laboratory

LAB ADDRESS : No. 81-1, Lu Liao Keng, 9th Ling,Wu Lung Tsuen,
Chiung Lin Hsiang, Hsin Chu Hsien 307, Taiwan

TEST LOCATION (1): No. 81-1, Lu Liao Keng, 9th Ling,Wu Lung Tsuen,
Chiung Lin Hsiang, Hsin Chu Hsien 307, Taiwan

TEST LOCATION (2): No. 49, Ln. 206, Wende Rd., Shangshan Tsuen,
Chiung Lin Hsiang, Hsin Chu Hsien 307, Taiwan

This test report consists of 79 pages in total. It may be duplicated completely for legal use with the approval of the applicant. It should not be reproduced except in full, without the written approval of our laboratory. The client should not use it to claim product certification, approval, or endorsement by TAF or any government agencies. The test results in the report only apply to the tested sample.





A D T

Table of Contents

RELEASE CONTROL RECORD	4
1. CERTIFICATION	5
2. SUMMARY OF TEST RESULTS	6
2.1 MEASUREMENT UNCERTAINTY	7
3. GENERAL INFORMATION	8
3.1 GENERAL DESCRIPTION OF EUT	8
3.2 DESCRIPTION OF TEST MODES	10
3.2.1 TEST MODE APPLICABILITY AND TESTED CHANNEL DETAIL	11
3.3 GENERAL DESCRIPTION OF APPLIED STANDARDS	14
3.4 DESCRIPTION OF SUPPORT UNITS.....	15
3.5 CONFIGURATION OF SYSTEM UNDER TEST	17
4. TEST TYPES AND RESULTS	19
4.1 CONDUCTED EMISSION MEASUREMENT	19
4.1.1 LIMITS OF CONDUCTED EMISSION MEASUREMENT	19
4.1.2 TEST INSTRUMENTS.....	19
4.1.3 TEST PROCEDURES	20
4.1.4 DEVIATION FROM TEST STANDARD	20
4.1.5 TEST SETUP	21
4.1.6 EUT OPERATING CONDITIONS	21
4.1.7 TEST RESULTS	22
4.2 RADIATED EMISSION MEASUREMENT	24
4.2.1 LIMITS OF RADIATED EMISSION MEASUREMENT	24
4.2.2 TEST INSTRUMENTS.....	25
4.2.3 TEST PROCEDURES	26
4.2.4 DEVIATION FROM TEST STANDARD	26
4.2.5 TEST SETUP	27
4.2.6 EUT OPERATING CONDITIONS	27
4.2.7 TEST RESULTS	28
4.3 6dB BANDWIDTH MEASUREMENT	57
4.3.1 LIMITS OF 6dB BANDWIDTH MEASUREMENT	57
4.3.2 TEST INSTRUMENTS.....	57
4.3.3 TEST PROCEDURE.....	57
4.3.4 DEVIATION FROM TEST STANDARD	57
4.3.5 TEST SETUP	57
4.3.6 EUT OPERATING CONDITIONS	57
4.3.7 TEST RESULTS	58
4.4 MAXIMUM PEAK OUTPUT POWER.....	62
4.4.1 LIMITS OF MAXIMUM PEAK OUTPUT POWER MEASUREMENT	62
4.4.2 INSTRUMENTS.....	62
4.4.3 TEST PROCEDURES	62



A D T

4.4.4	DEVIATION FROM TEST STANDARD	62
4.4.5	TEST SETUP	62
4.4.6	EUT OPERATING CONDITIONS	62
4.4.7	TEST RESULTS	63
4.5	POWER SPECTRAL DENSITY MEASUREMENT	64
4.5.1	LIMITS OF POWER SPECTRAL DENSITY MEASUREMENT	64
4.5.2	TEST INSTRUMENTS.....	64
4.5.3	TEST PROCEDURE.....	64
4.5.4	DEVIATION FROM TEST STANDARD	64
4.5.5	TEST SETUP	64
4.5.6	EUT OPERATING CONDITION.....	64
4.5.7	TEST RESULTS	65
4.6	CONDUCTED OUT-BAND EMISSION MEASUREMENT	69
4.6.1	LIMITS OF CONDUCTED OUT-BAND EMISSION MEASUREMENT.....	69
4.6.2	TEST INSTRUMENTS.....	69
4.6.3	TEST PROCEDURE.....	69
4.6.4	DEVIATION FROM TEST STANDARD	69
4.6.5	EUT OPERATING CONDITION	69
4.6.6	TEST RESULTS	69
5.	INFORMATION ON THE TESTING LABORATORIES	78
6.	APPENDIX A - MODIFICATIONS RECORDERS FOR ENGINEERING CHANGES TO THE EUT BY THE LAB.....	79



A D T

RELEASE CONTROL RECORD

ISSUE NO.	REASON FOR CHANGE	DATE ISSUED
RF110317E07A	Original release	Sep. 14, 2011



A D T

1. CERTIFICATION

PRODUCT: WiMAX Indoor VoIP Wi-Fi IAD
BRAND NAME: MitraStar
MODEL NO.: HES-209M2W
TEST SAMPLE: MASS-PRODUCTION
APPLICANT: MitraStar Technology Corporation
TESTED: Apr. 07 to 13, 2011
STANDARDS: FCC Part 15, Subpart C (Section 15.247)
ANSI C63.4-2003
ANSI C63.10-2009

The above equipment has been tested by **Bureau Veritas Consumer Products Services (H.K.) Ltd., Taoyuan Branch**, and found compliance with the requirement of the above standards. The test record, data evaluation & Equipment Under Test (EUT) configurations represented herein are true and accurate accounts of the measurements of the sample's EMC characteristics under the conditions specified in this report.

PREPARED BY :  , **DATE:** Sep. 14, 2011
(Claire Kuan, Specialist)

APPROVED BY :  , **DATE:** Sep. 14, 2011
(May Chen, Deputy Manager)

2. SUMMARY OF TEST RESULTS

The EUT has been tested according to the following specifications:

APPLIED STANDARD: FCC Part 15, Subpart C			
Standard Section	Test Type and Limit	Result	Remark
15.207	AC Power Conducted Emission	PASS	Meet the requirement of limit. Minimum passing margin is -14.03dB at 0.192MHz and 0.197MHz
15.247(a)(2)	Spectrum Bandwidth of a Direct Sequence Spread Spectrum System Limit: min. 500kHz	PASS	Meet the requirement of limit.
15.247(b)	Maximum Peak Output Power Limit: max. 30dBm	PASS	Meet the requirement of limit.
15.247(d)	Radiated Emissions Limit: Table 15.209	PASS	Meet the requirement of limit. Minimum passing margin is -0.6dB at 2483.5 MHz
15.247(e)	Power Spectral Density Limit: max. 8dBm	PASS	Meet the requirement of limit.
15.247(d)	Conducted Out-Band Emission Measurement Limit: 20dB less than the peak value of fundamental frequency	PASS	Meet the requirement of limit.
15.203	Antenna Requirement	PASS	Antenna connector is I-PEX not a standard connector.



A D T

2.1 MEASUREMENT UNCERTAINTY

Where relevant, the following measurement uncertainty levels have been estimated for tests performed on the EUT as specified in CISPR 16-4-2:

This uncertainty represents an expanded uncertainty expressed at approximately the 95% confidence level using a coverage factor of $k=2$.

Measurement	Value
Conducted emissions	2.45 dB
Radiated emissions (30MHz-1GHz)	3.3 dB
Radiated emissions (1GHz -18GHz)	2.19 dB
Radiated emissions (18GHz -40GHz)	2.55 dB



A D T

3. GENERAL INFORMATION

3.1 GENERAL DESCRIPTION OF EUT

PRODUCT	WiMAX Indoor VoIP Wi-Fi IAD
MODEL NO.	HES-209M2W
FCC ID	ZMYHES209M2W
POWER SUPPLY	DC 12V from power adapter
MODULATION TYPE	CCK, DQPSK, DBPSK for DSSS 64QAM, 16QAM, QPSK, BPSK for OFDM
MODULATION TECHNOLOGY	DSSS, OFDM
TRANSFER RATE	802.11b: 11 / 5.5 / 2 / 1Mbps 802.11g: 54 / 48 / 36 / 24 / 18 / 12 / 9 / 6Mbps 802.11n (20MHz, 800ns GI): 65 / 58.5 / 52 / 39 / 26 / 19.5 / 13 / 6.5Mbps 802.11n (40MHz, 800ns GI): 135 / 121.5 / 108 / 81 / 54 / 40.5 / 27 / 13.5Mbps 802.11n (20MHz, 400ns GI): 72.2 / 65 / 57.8 / 43.3 / 28.9 / 21.7 / 14.4 / 7.2Mbps 802.11n (40MHz, 400ns GI): 150 / 135 / 120 / 90 / 60 / 45 / 30 / 15Mbps
FREQUENCY RANGE	2412MHz ~ 2462MHz
NUMBER OF CHANNEL	11 for 802.11b, 802.11g, 802.11n (20MHz) 7 for 802.11n (40MHz)
MAXIMUM OUTPUT POWER	802.11b: 117.5mW 802.11g: 288.4mW 802.11n (20MHz): 302.0mW 802.11n (40MHz): 239.9mW
ANTENNA TYPE	Please see note
DATA CABLE	NA
I/O PORTS	Ethernet port x 2 (Ethernet (10,100 Mbps)) VOIP port x 2
ASSOCIATED DEVICES	Adapter x 1

NOTE:

1. There are WiMAX technology and WiFi technology used for the EUT, this report was recorded the **WiFi** test data. For the WiMAX test data was recorded in another test report< RF110317E07A-1>.
2. Spurious emission of the simultaneous operation (WiFi & WiMAX) has been evaluated and no non-compliance found.
3. There are antennas provided to this EUT, please refer to the following table:

WiMAX EXTERNAL ANTENNA				
No.	Transmitter Circuit	Antenna Type	Antenna Connector	Antenna Gain (dBi)
1	Chain(0)	Dipole	R-SMA	7
2	Chain(1)	Dipole	R-SMA	7
WiMAX INTERNAL ANTENNA				
No.	Transmitter Circuit	Antenna Type	Antenna Connector	Antenna Gain (dBi)
1	Chain(0)	PCB	IPEX	6
2	Chain(1)	PCB	IPEX	6
WiFi ANTENNA				
No.	Antenna Type	Antenna Connector	Antenna Gain (dBi)	
1	Printed	I-PEX	2	

4. The EUT must be supplied with a power adapter as following table:

Brand	Model No.	Spec.
PHIHONG	PSA24R-120	AC Input: 100-240V, 50-60Hz, 0.6A DC Output: 12V, 2A DC output cable(Unshielded, 1.5m)

5. The EUT is 1 * 1 spatial SISO (1Tx & 1Rx) without beam forming function.
6. When the EUT operating in 802.11n, the software operation, which is defined by manufacturer, MCS (Modulation and Coding Schemes) from 0 to 7.
7. The above EUT information was declared by manufacturer and for more detailed features description, please refer to the manufacturer's specifications or user's manual.



A D T

3.2 DESCRIPTION OF TEST MODES

Eleven channels are provided for 802.11b, 802.11g, 802.11n (20MHz):

CHANNEL	FREQUENCY	CHANNEL	FREQUENCY
1	2412MHz	7	2442MHz
2	2417MHz	8	2447MHz
3	2422MHz	9	2452MHz
4	2427MHz	10	2457MHz
5	2432MHz	11	2462MHz
6	2437MHz		

Seven channels are provided for 802.11n (40MHz):

CHANNEL	FREQUENCY	CHANNEL	FREQUENCY
3	2422MHz	7	2442MHz
4	2427MHz	8	2447MHz
5	2432MHz	9	2452MHz
6	2437MHz		

3.2.1 TEST MODE APPLICABILITY AND TESTED CHANNEL DETAIL

EUT CONFIGURE MODE	APPLICABLE TO				DESCRIPTION
	PLC	RE < 1G	RE ≥ 1G	APCM	
-	√	√	√	√	-

Where **PLC**: Power Line Conducted Emission

RE < 1G: Radiated Emission below 1GHz

RE ≥ 1G: Radiated Emission above 1GHz

APCM: Antenna Port Conducted Measurement

POWER LINE CONDUCTED EMISSION TEST:

- Pre-Scan has been conducted to determine the worst-case mode from all possible combinations between available modulations, data rates and antenna ports (if EUT with antenna diversity architecture).
- Following channel(s) was (were) selected for the final test as listed below.

MODE	AVAILABLE CHANNEL	TESTED CHANNEL	MODULATION TECHNOLOGY	MODULATION TYPE	DATA RATE (Mbps)
802.11n (20MHz)	1 to 11	6	OFDM	BPSK	6.5

RADIATED EMISSION TEST (BELOW 1 GHz):

- Pre-Scan has been conducted to determine the worst-case mode from all possible combinations between available modulations, data rates and antenna ports (if EUT with antenna diversity architecture).
- Following channel(s) was (were) selected for the final test as listed below.

MODE	AVAILABLE CHANNEL	TESTED CHANNEL	MODULATION TECHNOLOGY	MODULATION TYPE	DATA RATE (Mbps)
802.11n (20MHz)	1 to 11	6	OFDM	BPSK	6.5



A D T

RADIATED EMISSION TEST (ABOVE 1 GHz):

- Pre-Scan has been conducted to determine the worst-case mode from all possible combinations between available modulations, data rates and antenna ports (if EUT with antenna diversity architecture).
- Following channel(s) was (were) selected for the final test as listed below.

MODE	AVAILABLE CHANNEL	TESTED CHANNEL	MODULATION TECHNOLOGY	MODULATION TYPE	DATA RATE (Mbps)
802.11b	1 to 11	1, 6, 11	DSSS	DBPSK	1
802.11g	1 to 11	1, 6, 11	OFDM	BPSK	6
802.11n (20MHz)	1 to 11	1, 6, 11	OFDM	BPSK	6.5
802.11n (40MHz)	3 to 9	3, 6, 9	OFDM	BPSK	13.5

CONDUCTED OUT-BAND EMISSION MEASUREMENT:

- Pre-Scan has been conducted to determine the worst-case mode from all possible combinations between available modulations, data rates and antenna ports (if EUT with antenna diversity architecture).
- Following channel(s) was (were) selected for the final test as listed below.

MODE	AVAILABLE CHANNEL	TESTED CHANNEL	MODULATION TECHNOLOGY	MODULATION TYPE	DATA RATE (Mbps)
802.11b	1 to 11	1, 11	DSSS	DBPSK	1
802.11g	1 to 11	1, 11	OFDM	BPSK	6
802.11n (20MHz)	1 to 11	1, 11	OFDM	BPSK	6.5
802.11n (40MHz)	3 to 9	3, 9	OFDM	BPSK	13.5



A D T

ANTENNA PORT CONDUCTED MEASUREMENT:

- This item includes all test value of each mode, but only includes spectrum plot of worst value of each mode.
- Pre-Scan has been conducted to determine the worst-case mode from all possible combinations between available modulations, data rates and antenna ports (if EUT with antenna diversity architecture).
- Following channel(s) was (were) selected for the final test as listed below.

MODE	AVAILABLE CHANNEL	TESTED CHANNEL	MODULATION TECHNOLOGY	MODULATION TYPE	DATA RATE (Mbps)
802.11b	1 to 11	1, 6, 11	DSSS	DBPSK	1
802.11g	1 to 11	1, 6, 11	OFDM	BPSK	6
802.11n (20MHz)	1 to 11	1, 6, 11	OFDM	BPSK	6.5
802.11n (40MHz)	3 to 9	3, 6, 9	OFDM	BPSK	13.5

TEST CONDITION:

APPLICABLE TO	ENVIRONMENTAL CONDITIONS	INPUT POWER	TESTED BY
RE ³ 1G	22deg. C, 66%RH, 1022 hPa	120Vac, 60Hz	Evan Huang
RE<1G	19deg. C, 60%RH, 1022 hPa	120Vac, 60Hz	Kent Liu
PLC	15deg. C, 69%RH, 1022 hPa	120Vac, 60Hz	Frank Liu
APCM	25deg. C, 60%RH, 1022 hPa	120Vac, 60Hz	Frank Liu

3.3 GENERAL DESCRIPTION OF APPLIED STANDARDS

The EUT is a RF product. According to the specifications of the manufacturer, it must comply with the requirements of the following standards:

FCC Part 15, Subpart C (15.247)

ANSI C63.4-2003

ANSI C63.10-2009

All test items have been performed and recorded as per the above standards.

NOTE: The EUT is also considered as a kind of computer peripheral, because the connection to computer is necessary for typical use. It has been verified to comply with the requirements of FCC Part 15, Subpart B, Class B (DoC). The test report has been issued separately.



A D T

3.4 DESCRIPTION OF SUPPORT UNITS

The EUT has been tested as an independent unit together with other necessary accessories or support units. The following support units or accessories were used to form a representative test configuration during the tests.

Conducted Emission test					
NO.	PRODUCT	BRAND	MODEL NO.	SERIAL NO.	FCC ID
1	NOTEBOOK COMPUTER	DELL	PP32LA	DSL32S	FCC DoC
2	NOTEBOOK COMPUTER	DELL	E6400	D814C A00 APCC	FCC DoC
3	NOTEBOOK COMPUTER	DELL	PP17L	CN-ONF743-48643-7AV-0124	FCC DoC
4	HUB	ZyXEL	ES-116P	S060H02000215	FCC DoC
5	WiMAX Indoor VoIP Wi-Fi IAD	MitraStar	HES-209M2W	NA	NA
6	TELEPHONE	WONDER	WD-303	6C17FA00774	NA
7	TELEPHONE	DAISHO	DS-03	NA	NA
8	TELEPHONE	ROMEO	TE-812	97280926	NA
9	ESG Vector signal generator	Agilent	E4438C	MY47271330 506 602 UNJ	NA

Conducted Emission test	
NO.	SIGNAL CABLE DESCRIPTION OF THE ABOVE SUPPORT UNITS
1	NA
2	10m UTP cable
3	1.6m UTP cable
4	10m UTP cable
5	1.6m UTP cable
6	1.7m TEL line
7	10m TEL line
8	10m TEL line
9	NA

NOTE: 1. All power cords of the above support units are non shielded (1.8m).



A D T

other test items					
NO.	PRODUCT	BRAND	MODEL NO.	SERIAL NO.	FCC ID
1	NOTEBOOK COMPUTER	DELL	E6400	D814C A00 APCC	FCC DoC
2	NOTEBOOK COMPUTER	DELL	PP17L	CN-ONF743-48643-7A V-0124	FCC DoC
3	HUB	ZyXEL	ES-116P	S060H02000215	FCC DoC
4	WiMAX Indoor VoIP Wi-Fi IAD	MitraStar	HES-209M2W	NA	NA
5	TELEPHONE	WONDER	WD-303	6C17FA00774	NA
6	TELEPHONE	DAISHO	DS-03	NA	NA
7	TELEPHONE	ROMEO	TE-812	97280926	NA

other test items	
NO.	SIGNAL CABLE DESCRIPTION OF THE ABOVE SUPPORT UNITS
1	10m UTP cable
2	1.6m UTP cable
3	10m UTP cable
4	1.6m UTP cable
5	1.7m TEL line
6	1.7m TEL line
7	1.7m TEL line

NOTE: 1. All power cords of the above support units are non shielded (1.8m).

3.5 CONFIGURATION OF SYSTEM UNDER TEST

For conducted Emission test:

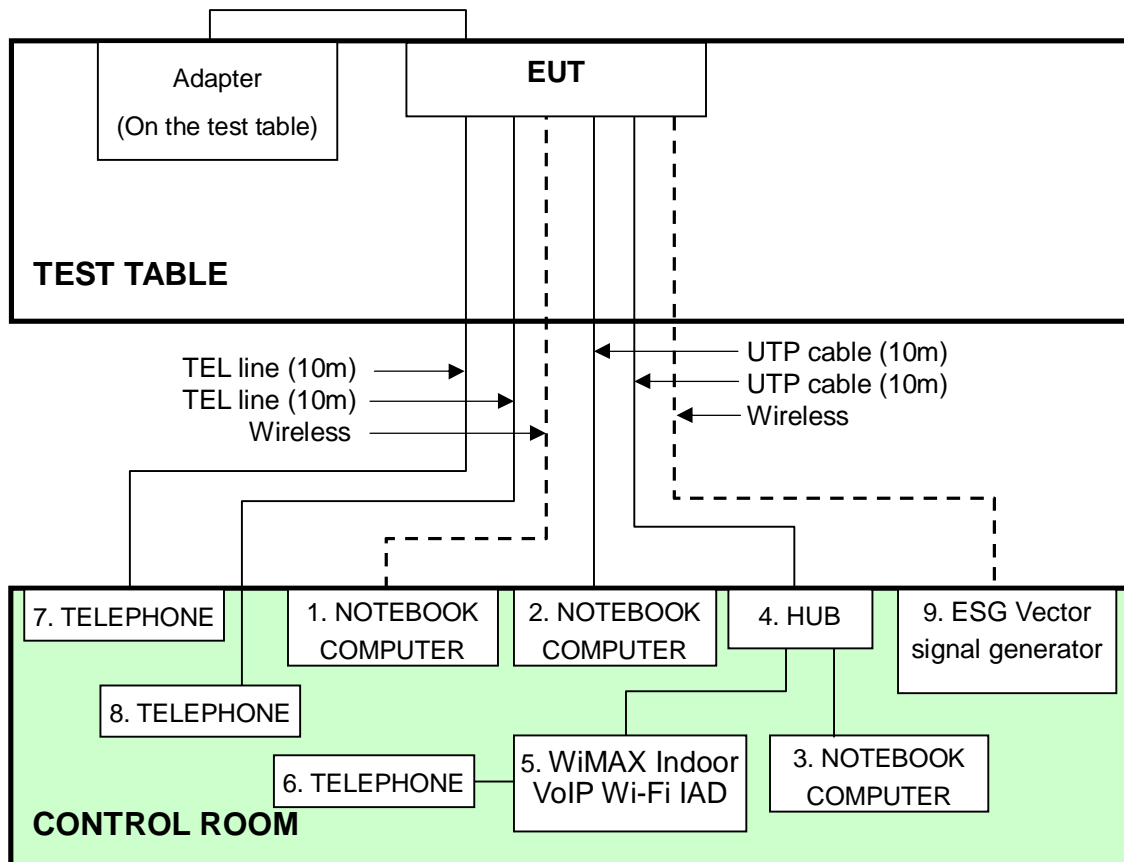

For other test items:

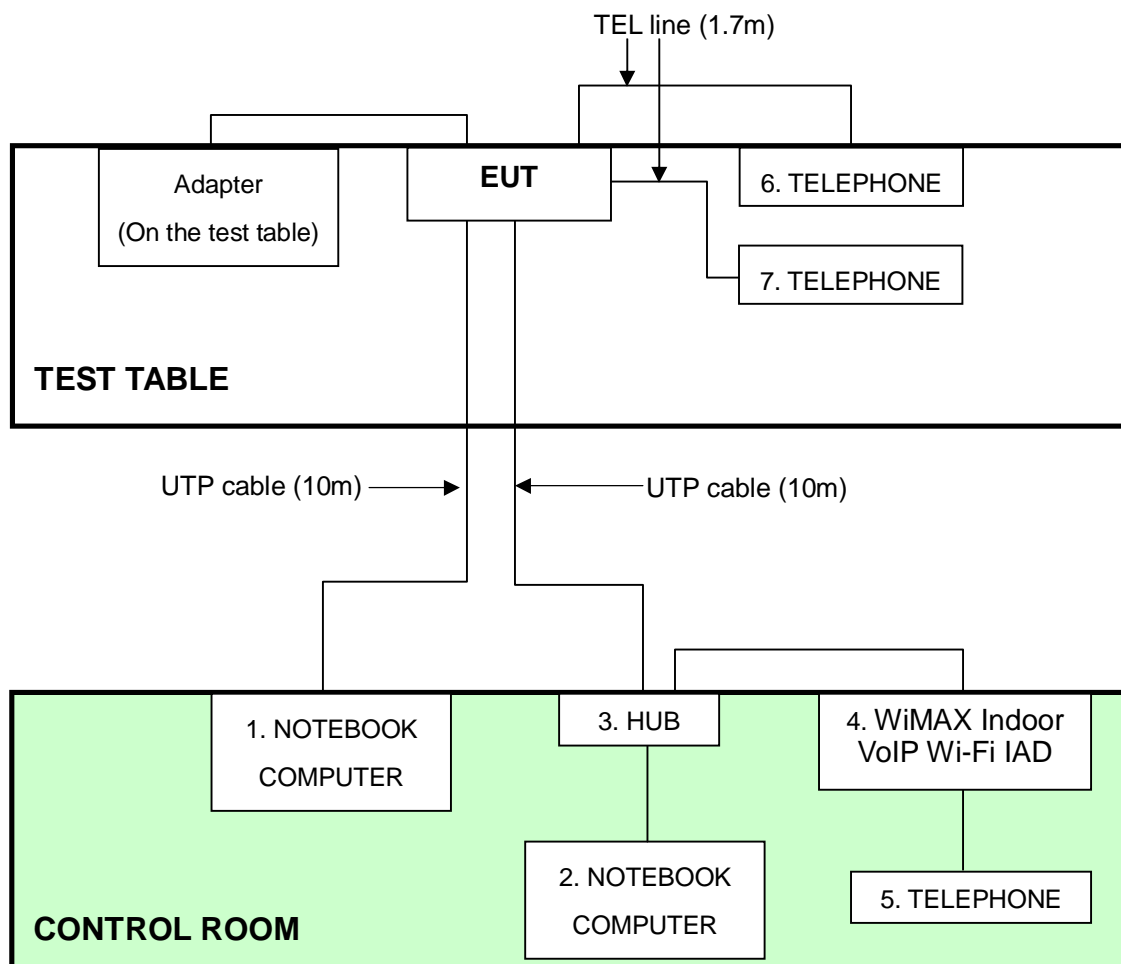



A D T

4. TEST TYPES AND RESULTS

4.1 CONDUCTED EMISSION MEASUREMENT

4.1.1 LIMITS OF CONDUCTED EMISSION MEASUREMENT

FREQUENCY OF EMISSION (MHz)	CONDUCTED LIMIT (dBµV)	
	Quasi-peak	Average
0.15-0.5	66 to 56	56 to 46
0.5-5	56	46
5-30	60	50

- NOTE:**
1. The lower limit shall apply at the transition frequencies.
 2. The limit decreases in line with the logarithm of the frequency in the range of 0.15 to 0.50 MHz.
 3. All emanations from a class A/B digital device or system, including any network of conductors and apparatus connected thereto, shall not exceed the level of field strengths specified above.

4.1.2 TEST INSTRUMENTS

DESCRIPTION & MANUFACTURER	MODEL NO.	SERIAL NO.	CALIBRATED DATE	CALIBRATED UNTIL
Test Receiver	ESCS 30	100375	Mar. 09, 2011	Mar. 08, 2012
Line-Impedance Stabilization Network (for EUT)	NSLK 8127	8127-522	Sep. 08, 2010	Sep. 07, 2011
Line-Impedance Stabilization Network (for Peripheral)	ESH3-Z5	848773/004	Nov. 03, 2010	Nov. 02, 2011
RF Cable (JYEBAO)	5DFB	COCCAB-002	Aug. 30, 2010	Aug. 29, 2011
50 ohms Terminator	50	3	Nov. 03, 2010	Nov. 02, 2011
Software	BV ADT_Cond_V7.3.7	NA	NA	NA

Note:

1. The calibration interval of the above test instruments is 12 months and the calibrations are traceable to NML/ROC and NIST/USA.
2. The test was performed in Shielded Room No. C.
3. The VCCI Con C Registration No. is C-3611.

4.1.3 TEST PROCEDURES

- a. The EUT was placed 0.4 meters from the conducting wall of the shielded room with EUT being connected to the power mains through a line impedance stabilization network (LISN). Other support units were connected to the power mains through another LISN. The two LISNs provide 50 ohm/ 50uH of coupling impedance for the measuring instrument.
- b. Both lines of the power mains connected to the EUT were checked for maximum conducted interference.
- c. The frequency range from 150kHz to 30MHz was searched. Emission levels under (Limit - 20dB) were not recorded.

4.1.4 DEVIATION FROM TEST STANDARD

No deviation

4.1.5 TEST SETUP

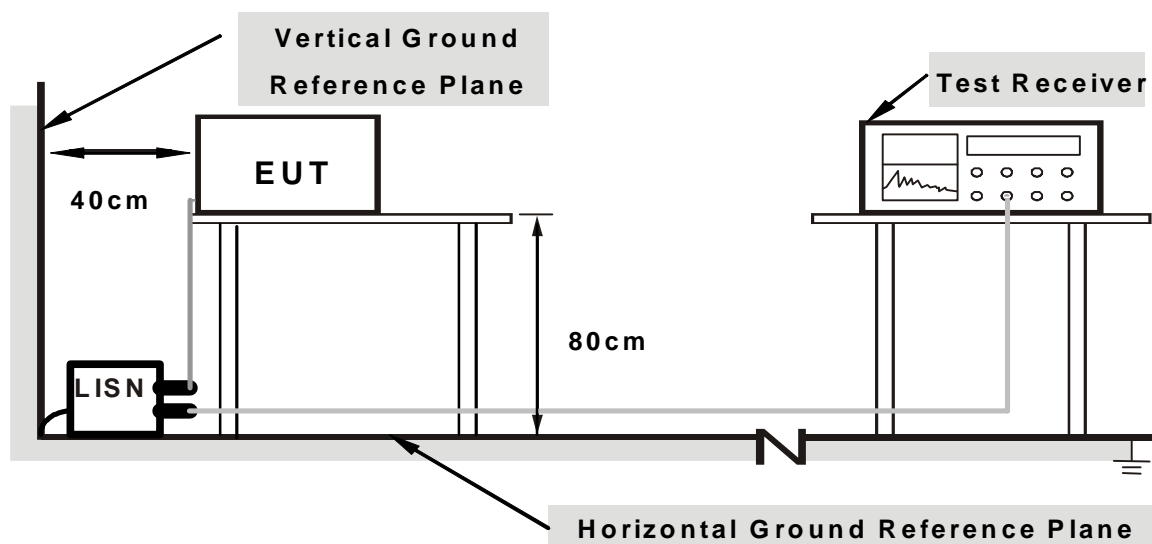

Note: 1.Support units were connected to second LISN.

2.Both of LISNs (AMN) are 80 cm from EUT and at least 80 from other units and other metal planes

For the actual test configuration, please refer to the related item – Photographs of the Test Configuration.

4.1.6 EUT OPERATING CONDITIONS

1. Turn on the power of all equipment.
2. Prepare other computer system support units 1~3 (Notebook Computer) to act as communication partners and placed them outside of testing area.
3. Support units 1~2 (Notebook Computer) run a test program “Ping.exe” to enable of EUT via one UTP cable and wireless continuously.
4. Support unit 9 (ESG Vector signal generator) link with EUT via WiMAX.
5. Support unit 6 (Telephone) communicates to support unit 8 (Telephone) via EUT by TEL lines.

4.1.7 TEST RESULTS

PHASE	Line (L)	6dB BANDWIDTH	9 kHz
--------------	----------	----------------------	-------

No	Freq.	Corr.	Reading Value		Emission Level		Limit		Margin	
	[MHz]	Factor	[dB (uV)]		[dB (uV)]		[dB (uV)]		(dB)	
		(dB)	Q.P.	AV.	Q.P.	AV.	Q.P.	AV.	Q.P.	AV.
1	0.197	0.13	49.60	-	49.73	-	63.75	53.75	-14.03	-
2	0.259	0.13	43.51	-	43.64	-	61.45	51.45	-17.81	-
3	0.333	0.13	41.98	-	42.11	-	59.38	49.38	-17.27	-
4	1.262	0.15	35.46	-	35.61	-	56.00	46.00	-20.39	-
5	4.301	0.21	25.70	-	25.91	-	56.00	46.00	-30.09	-
6	18.242	0.63	30.12	-	30.75	-	60.00	50.00	-29.25	-

- REMARKS:**
1. Q.P. and AV. are abbreviations of quasi-peak and average individually.
 2. "-": The Quasi-peak reading value also meets average limit and measurement with the average detector is unnecessary.
 3. The emission levels of other frequencies were very low against the limit.
 4. Margin value = Emission level - Limit value
 5. Correction factor = Insertion loss + Cable loss
 6. Emission Level = Correction Factor + Reading Value.

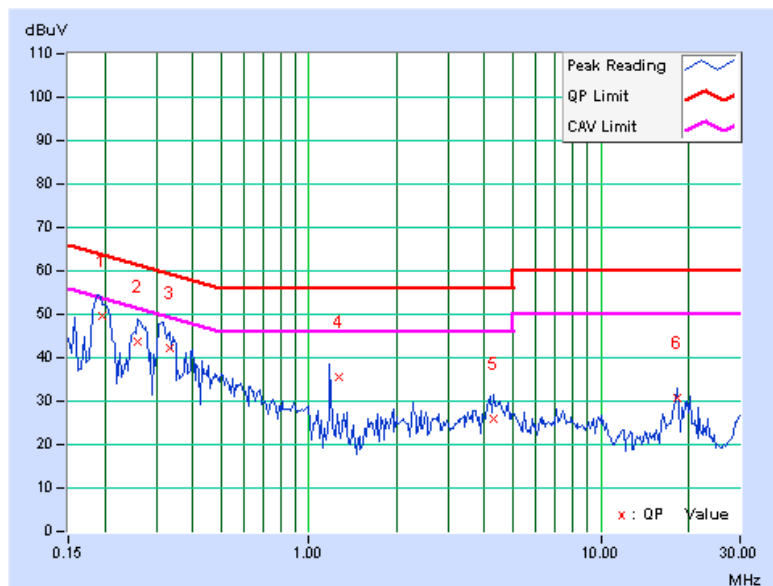

PHASE	Neutral (N)	6dB BANDWIDTH	9 kHz
--------------	-------------	----------------------	-------

No	Freq. [MHz]	Corr. Factor (dB)	Reading Value		Emission Level		Limit		Margin	
			[dB (uV)]		[dB (uV)]		[dB (uV)]		(dB)	
			Q.P.	AV.	Q.P.	AV.	Q.P.	AV.	Q.P.	AV.
1	0.192	0.14	49.78	-	49.92	-	63.94	53.94	-14.03	-
2	0.255	0.14	43.37	-	43.51	-	61.58	51.58	-18.06	-
3	0.314	0.15	43.96	-	44.11	-	59.86	49.86	-15.76	-
4	0.388	0.15	34.16	-	34.31	-	58.10	48.10	-23.79	-
5	1.262	0.17	35.39	-	35.56	-	56.00	46.00	-20.44	-
6	19.711	1.40	30.64	-	32.04	-	60.00	50.00	-27.96	-

- REMARKS:**
1. Q.P. and AV. are abbreviations of quasi-peak and average individually.
 2. "-": The Quasi-peak reading value also meets average limit and measurement with the average detector is unnecessary.
 3. The emission levels of other frequencies were very low against the limit.
 4. Margin value = Emission level - Limit value
 5. Correction factor = Insertion loss + Cable loss
 6. Emission Level = Correction Factor + Reading Value.

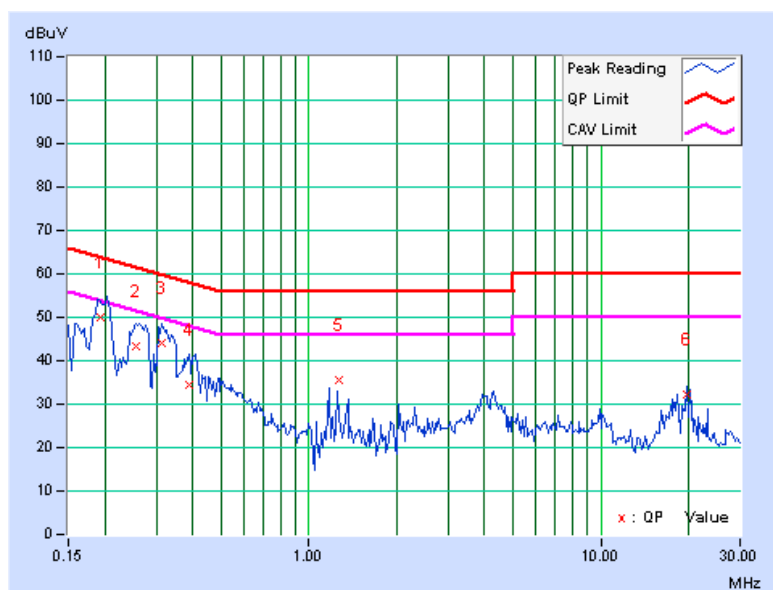

4.2 RADIATED EMISSION MEASUREMENT

4.2.1 LIMITS OF RADIATED EMISSION MEASUREMENT

Emissions radiated outside of the specified bands, shall be according to the general radiated limits in 15.209 as following:

Frequencies (MHz)	Field strength (microvolts/meter)	Measurement distance (meters)
0.009-0.490	2400/F(kHz)	300
0.490-1.705	24000/F(kHz)	30
1.705-30.0	30	30
30-88	100	3
88-216	150	3
216-960	200	3
Above 960	500	3

NOTE:

1. The lower limit shall apply at the transition frequencies.
2. Emission level (dBuV/m) = 20 log Emission level (uV/m).
3. As shown in 15.35(b), for frequencies above 1000MHz, the field strength limits are based on average detector, however, the peak field strength of any emission shall not exceed the maximum permitted average limits, specified above by more than 20dB under any condition of modulation.



A D T

4.2.2 TEST INSTRUMENTS

DESCRIPTION & MANUFACTURER	MODEL NO.	SERIAL NO.	CALIBRATED DATE	CALIBRATED UNTIL
Agilent Spectrum Analyzer	E4446A	MY48250254	July 14, 2010	July 13, 2011
Agilent Pre-Selector	N9039A	MY46520311	July 14, 2010	July 13, 2011
Agilent Signal Generator	N5181A	MY49060517	July 14, 2010	July 13, 2011
Mini-Circuits Pre-Amplifier	ZFL-1000VH2B	AMP-ZFL-03	Nov. 16, 2010	Nov. 15, 2011
Agilent Pre-Amplifier	8449B	3008A02578	July 05, 2010	July 04, 2011
Miteq Pre-Amplifier	AFS33-1800265 0-30-8P-44	881786	NA	NA
SCHWARZBECK Trilog Broadband Antenna	VULB 9168	9168-360	Apr. 29, 2010	Apr. 28, 2011
AISI Horn_Antenna	AIH.8018	0000320091110	Nov. 12, 2010	Nov. 11, 2011
SCHWARZBECK Horn_Antenna	BBHA 9170	9170-424	Oct. 08, 2010	Oct. 07, 2011
RF CABLE	NA	RF104-201 RF104-203 RF104-204	Dec. 27, 2010	Dec. 26, 2011
RF Cable	NA	CHGCAB_001	NA	NA
Software	ADT_Radiated_V8.7.05	NA	NA	NA
CT Antenna Tower & Turn Table	NA	NA	NA	NA

- Note: 1. The calibration interval of the above test instruments is 12 months and the calibrations are traceable to NML/ROC and NIST/USA.
 2. The horn antenna, preamplifier (model: 8449B) are used only for the measurement of emission frequency above 1GHz if tested.
 3. The test was performed in 966 Chamber No. G.
 4. The FCC Site Registration No. is 966073.
 5. The VCCI Site Registration No. is G-137.
 6. The CANADA Site Registration No. is IC 7450H-2.

4.2.3 TEST PROCEDURES

- a. The EUT was placed on the top of a rotating table 0.8 meters above the ground at 3 meters chamber room. The table was rotated 360 degrees to determine the position of the highest radiation.
- b. The EUT was set 3 meters away from the interference-receiving antenna, which was mounted on the top of a variable-height antenna tower.
- c. The height of antenna is varied from one meter to four meters above the ground to determine the maximum value of the field strength. Both horizontal and vertical polarizations of the antenna are set to make the measurement.
- d. For each suspected emission, the EUT was arranged to its worst case and then the antenna was tuned to heights from 1 meter to 4 meters and the rotatable table was turned from 0 degrees to 360 degrees to find the maximum reading.
- e. The test-receiver system was set to quasi-peak detect function and specified bandwidth with maximum hold mode when the test frequency is below 1 GHz.
- f. The test-receiver system was set to peak and average detect function and specified bandwidth with maximum hold mode when the test frequency is above 1 GHz. If the peak reading value also meets average limit, measurement with the average detector is unnecessary.

NOTE:

1. The resolution bandwidth and video bandwidth of test receiver/spectrum analyzer is 120kHz for Peak detection (PK) and Quasi-peak detection (QP) at frequency below 1GHz.
2. The resolution bandwidth of test receiver/spectrum analyzer is 1 MHz and video bandwidth is 3MHz for Peak detection at frequency above 1GHz.
3. The resolution bandwidth of test receiver/spectrum analyzer is 1MHz and the video bandwidth is 10Hz for Average detection (AV) at frequency above 1GHz.

4.2.4 DEVIATION FROM TEST STANDARD

No deviation

4.2.5 TEST SETUP

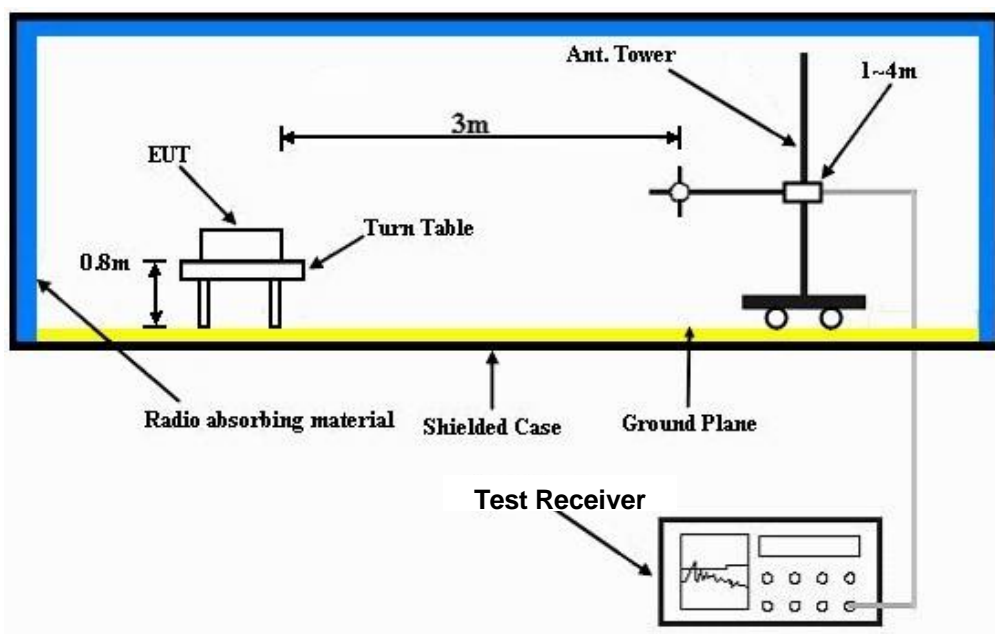

For the actual test configuration, please refer to the related item – Photographs of the Test Configuration.

4.2.6 EUT OPERATING CONDITIONS

1. Turn on the power of all equipment.
2. The support unit 1 (Notebook Computer) runs test program “RT3x7x V1.5.2.2 AP” to enable EUT under transmission/receiving condition continuously via one UTP cable.

4.2.7 TEST RESULTS

BELOW 1GHz WORST-CASE DATA : 802.11n (20MHz) OFDM MODULATION

EUT TEST CONDITION		MEASUREMENT DETAIL	
CHANNEL	Channel 6	FREQUENCY RANGE	Below 1000MHz
INPUT POWER	120Vac, 60 Hz	DETECTOR FUNCTION	Quasi-Peak
ENVIRONMENTAL CONDITIONS	19deg. C, 60%RH 1022 hPa	TESTED BY	Kent Liu

ANTENNA POLARITY & TEST DISTANCE: HORIZONTAL AT 3 M								
NO.	FREQ. (MHz)	EMISSION LEVEL (dBuV/m)	LIMIT (dBuV/m)	MARGIN (dB)	ANTENNA HEIGHT (m)	TABLE ANGLE (Degree)	RAW VALUE (dBuV)	CORRECTION FACTOR (dB/m)
1	108.75	36.5 QP	43.5	-7.1	1.50 H	0	25.59	10.86
2	162.40	33.6 QP	43.5	-9.9	1.25 H	360	19.20	14.40
3	277.86	38.1 QP	46.0	-7.9	1.00 H	32	23.56	14.55
4	500.02	33.9 QP	46.0	-12.1	2.00 H	233	13.82	20.10
5	750.01	35.6 QP	46.0	-10.4	1.00 H	43	11.25	24.33
6	940.67	30.4 QP	46.0	-15.6	1.00 H	51	3.24	27.15
ANTENNA POLARITY & TEST DISTANCE: VERTICAL AT 3 M								
NO.	FREQ. (MHz)	EMISSION LEVEL (dBuV/m)	LIMIT (dBuV/m)	MARGIN (dB)	ANTENNA HEIGHT (m)	TABLE ANGLE (Degree)	RAW VALUE (dBuV)	CORRECTION FACTOR (dB/m)
1	47.76	35.0 QP	40.0	-5.0	1.00 V	21	20.85	14.17
2	98.45	39.0 QP	43.5	-4.5	1.00 V	308	29.65	9.34
3	111.59	37.4 QP	43.5	-6.1	1.00 V	302	26.08	11.32
4	162.40	32.9 QP	43.5	-10.6	1.50 V	311	18.54	14.40
5	277.27	32.9 QP	46.0	-13.1	1.50 V	331	18.33	14.53
6	374.97	31.4 QP	46.0	-14.6	1.00 V	36	14.31	17.12
7	750.01	31.9 QP	46.0	-14.1	1.00 V	251	7.61	24.33

- REMARKS:**
1. Emission level (dBuV/m) = Raw Value (dBuV) + Correction Factor (dB/m).
 2. Correction Factor (dB/m) = Antenna Factor (dB/m) + Cable Factor (dB).
 3. The other emission levels were very low against the limit.
 4. Margin value = Emission level – Limit value.



A D T

ABOVE 1GHz WORST-CASE DATA

802.11b DSSS MODULATION

EUT TEST CONDITION		MEASUREMENT DETAIL	
CHANNEL	Channel 1	FREQUENCY RANGE	1 ~ 25GHz
INPUT POWER	120Vac, 60 Hz	DETECTOR FUNCTION	Peak (PK) Average (AV)
ENVIRONMENTAL CONDITIONS	22deg. C, 66%RH 1022 hPa	TESTED BY	Evan Huang

ANTENNA POLARITY & TEST DISTANCE: HORIZONTAL AT 3 M								
NO.	FREQ. (MHz)	EMISSION LEVEL (dBuV/m)	LIMIT (dBuV/m)	MARGIN (dB)	ANTENNA HEIGHT (m)	TABLE ANGLE (Degree)	RAW VALUE (dBuV)	CORRECTION FACTOR (dB/m)
1	2386.30	60.6 PK	74.0	-13.4	1.18 H	0	28.96	31.64
2	2386.30	51.9 AV	54.0	-2.1	1.18 H	0	20.26	31.64
3	*2412.00	112.5 PK			1.38 H	348	80.77	31.73
4	*2412.00	110.1 AV			1.38 H	348	78.37	31.73
5	4824.00	54.6 PK	74.0	-19.4	1.25 H	312	15.63	38.97
6	4824.00	53.1 AV	54.0	-0.9	1.25 H	312	14.13	38.97
ANTENNA POLARITY & TEST DISTANCE: VERTICAL AT 3 M								
NO.	FREQ. (MHz)	EMISSION LEVEL (dBuV/m)	LIMIT (dBuV/m)	MARGIN (dB)	ANTENNA HEIGHT (m)	TABLE ANGLE (Degree)	RAW VALUE (dBuV)	CORRECTION FACTOR (dB/m)
1	2386.32	56.1 PK	74.0	-17.9	1.00 V	223	24.46	31.64
2	2386.32	46.5 AV	54.0	-7.5	1.00 V	223	14.86	31.64
3	*2412.00	106.4 PK			1.00 V	223	74.67	31.73
4	*2412.00	103.9 AV			1.00 V	223	72.17	31.73
5	4824.00	52.1 PK	74.0	-21.9	1.03 V	219	13.13	38.97
6	4824.00	47.2 AV	54.0	-6.8	1.03 V	219	8.23	38.97

- REMARKS:**
1. Emission level (dBuV/m) = Raw Value (dBuV) + Correction Factor (dB/m).
 2. Correction Factor (dB/m) = Antenna Factor (dB/m) + Cable Factor (dB).
 3. The other emission levels were very low against the limit.
 4. Margin value = Emission level – Limit value.
 5. “ * ”: Fundamental frequency.



A D T

EUT TEST CONDITION		MEASUREMENT DETAIL	
CHANNEL	Channel 6	FREQUENCY RANGE	1 ~ 25GHz
INPUT POWER	120Vac, 60 Hz	DETECTOR FUNCTION	Peak (PK) Average (AV)
ENVIRONMENTAL CONDITIONS	22deg. C, 66%RH 1022 hPa	TESTED BY	Evan Huang

ANTENNA POLARITY & TEST DISTANCE: HORIZONTAL AT 3 M								
NO.	FREQ. (MHz)	EMISSION LEVEL (dBuV/m)	LIMIT (dBuV/m)	MARGIN (dB)	ANTENNA HEIGHT (m)	TABLE ANGLE (Degree)	RAW VALUE (dBuV)	CORRECTION FACTOR (dB/m)
1	*2437.00	115.5 PK			1.09 H	341	83.69	31.81
2	*2437.00	113.4 AV			1.09 H	341	81.59	31.81
3	4874.00	54.2 PK	74.0	-19.8	1.56 H	185	15.06	39.14
4	4874.00	52.5 AV	54.0	-1.5	1.56 H	185	13.36	39.14
5	7311.00	50.3 PK	74.0	-23.7	1.15 H	288	3.67	46.63
6	7311.00	37.3 AV	54.0	-16.7	1.15 H	288	-9.33	46.63
ANTENNA POLARITY & TEST DISTANCE: VERTICAL AT 3 M								
NO.	FREQ. (MHz)	EMISSION LEVEL (dBuV/m)	LIMIT (dBuV/m)	MARGIN (dB)	ANTENNA HEIGHT (m)	TABLE ANGLE (Degree)	RAW VALUE (dBuV)	CORRECTION FACTOR (dB/m)
1	*2437.00	109.2 PK			1.00 V	224	77.39	31.81
2	*2437.00	106.2 AV			1.00 V	224	74.39	31.81
3	4874.00	51.7 PK	74.0	-22.3	1.04 V	244	12.56	39.14
4	4874.00	46.3 AV	54.0	-7.7	1.04 V	244	7.16	39.14
5	7311.00	50.3 PK	74.0	-23.7	1.03 V	214	3.67	46.63
6	7311.00	39.4 AV	54.0	-14.6	1.03 V	214	-7.23	46.63

- REMARKS:**
1. Emission level (dBuV/m) = Raw Value (dBuV) + Correction Factor (dB/m).
 2. Correction Factor (dB/m) = Antenna Factor (dB/m) + Cable Factor (dB).
 3. The other emission levels were very low against the limit.
 4. Margin value = Emission level – Limit value.
 5. “ * “: Fundamental frequency.



A D T

EUT TEST CONDITION		MEASUREMENT DETAIL	
CHANNEL	Channel 11	FREQUENCY RANGE	1 ~ 25GHz
INPUT POWER	120Vac, 60 Hz	DETECTOR FUNCTION	Peak (PK) Average (AV)
ENVIRONMENTAL CONDITIONS	22deg. C, 66%RH 1022 hPa	TESTED BY	Evan Huang

ANTENNA POLARITY & TEST DISTANCE: HORIZONTAL AT 3 M

NO.	FREQ. (MHz)	EMISSION LEVEL (dBuV/m)	LIMIT (dBuV/m)	MARGIN (dB)	ANTENNA HEIGHT (m)	TABLE ANGLE (Degree)	RAW VALUE (dBuV)	CORRECTION FACTOR (dB/m)
1	*2462.00	113.3 PK			1.39 H	342	81.41	31.89
2	*2462.00	111.1 AV			1.39 H	342	79.21	31.89
3	2487.70	60.4 PK	74.0	-13.6	1.10 H	347	28.42	31.98
4	2487.70	51.1 AV	54.0	-2.9	1.10 H	347	19.12	31.98
5	4924.00	54.8 PK	74.0	-19.2	1.24 H	308	15.49	39.31
6	4924.00	52.8 AV	54.0	-1.2	1.24 H	308	13.49	39.31
7	7386.00	50.4 PK	74.0	-23.6	1.14 H	289	3.80	46.60
8	7386.00	37.5 AV	54.0	-16.5	1.14 H	289	-9.10	46.60

ANTENNA POLARITY & TEST DISTANCE: VERTICAL AT 3 M

NO.	FREQ. (MHz)	EMISSION LEVEL (dBuV/m)	LIMIT (dBuV/m)	MARGIN (dB)	ANTENNA HEIGHT (m)	TABLE ANGLE (Degree)	RAW VALUE (dBuV)	CORRECTION FACTOR (dB/m)
1	*2462.00	107.2 PK			1.00 V	243	75.31	31.89
2	*2462.00	104.4 AV			1.00 V	243	72.51	31.89
3	2487.72	57.2 PK	74.0	-16.8	1.00 V	243	25.22	31.98
4	2487.72	45.7 AV	54.0	-8.3	1.00 V	243	13.72	31.98
5	4924.00	52.0 PK	74.0	-22.0	1.02 V	241	12.69	39.31
6	4924.00	46.7 AV	54.0	-7.3	1.02 V	241	7.39	39.31
7	7386.00	50.6 PK	74.0	-23.4	1.02 V	244	4.00	46.60
8	7386.00	39.6 AV	54.0	-14.4	1.02 V	244	-7.00	46.60

- REMARKS:**
1. Emission level (dBuV/m) = Raw Value (dBuV) + Correction Factor (dB/m).
 2. Correction Factor (dB/m) = Antenna Factor (dB/m) + Cable Factor (dB).
 3. The other emission levels were very low against the limit.
 4. Margin value = Emission level – Limit value.
 5. “ * “: Fundamental frequency.



A D T

RESTRICTED BANDEDGE (802.11b MODE, CH1, HORIZONTAL)

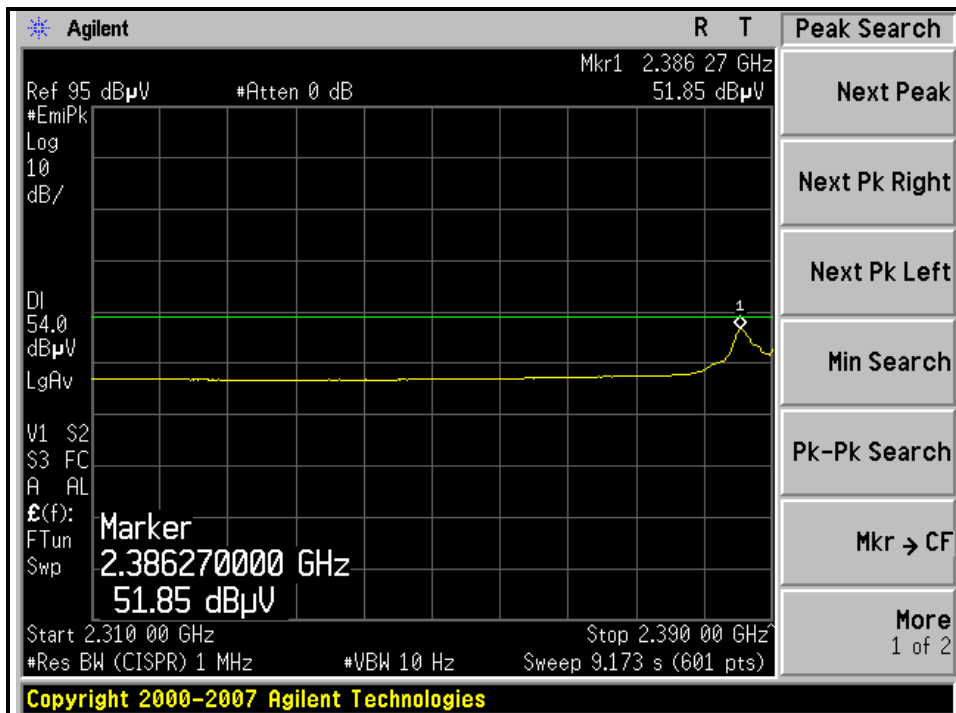
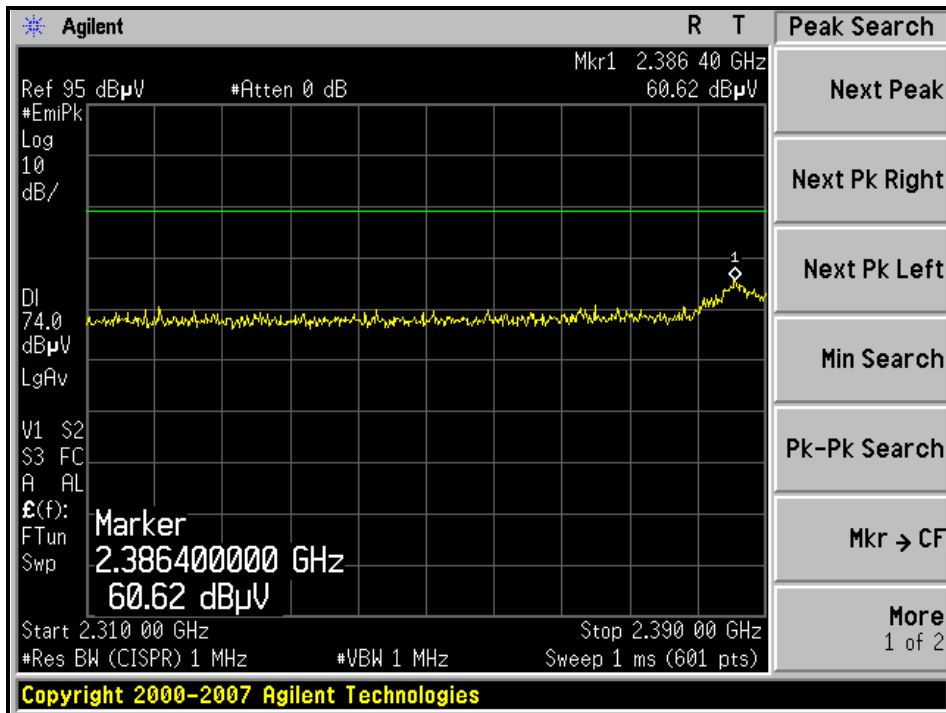

RESTRICTED BANDEDGE (802.11b MODE, CH1, VERTICAL)

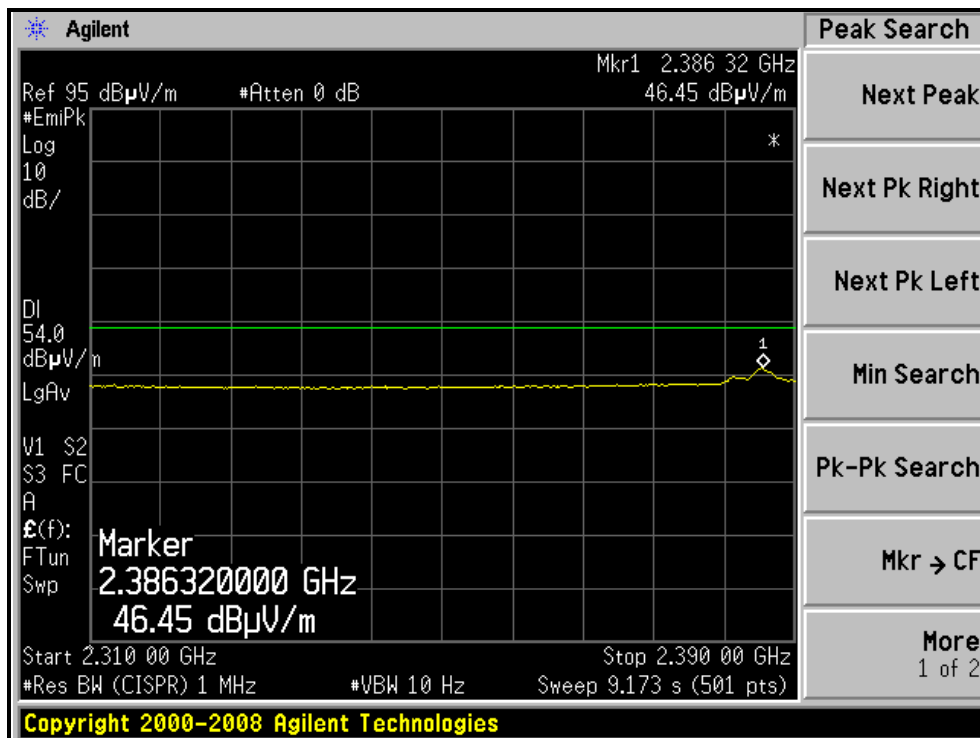
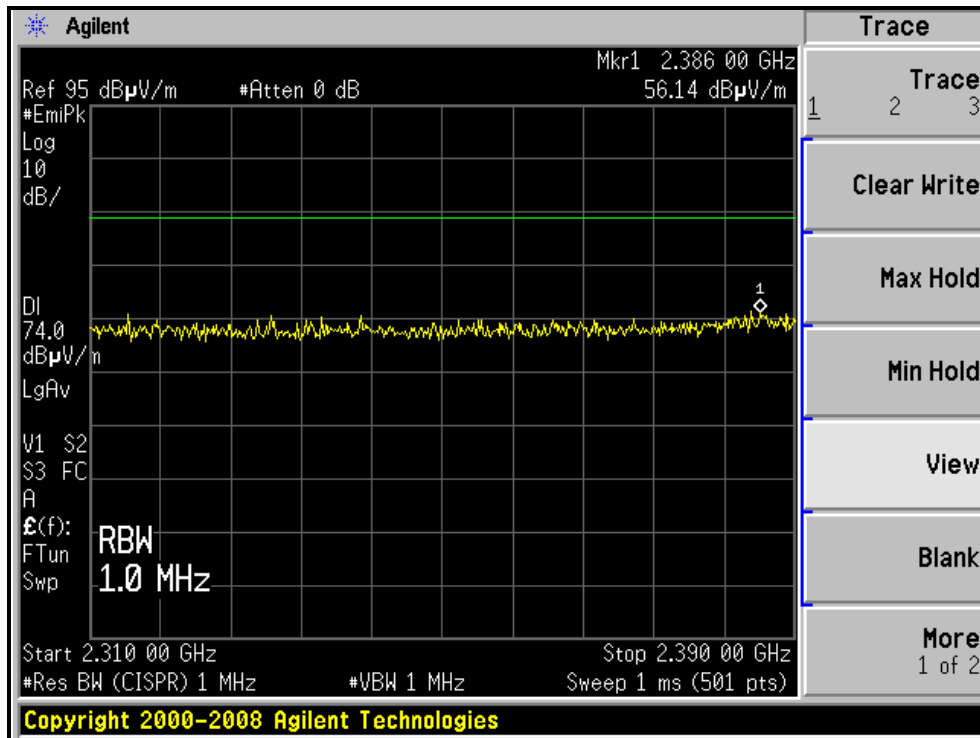



A D T

RESTRICTED BANDEDGE (802.11b MODE, CH11, HORIZONTAL)

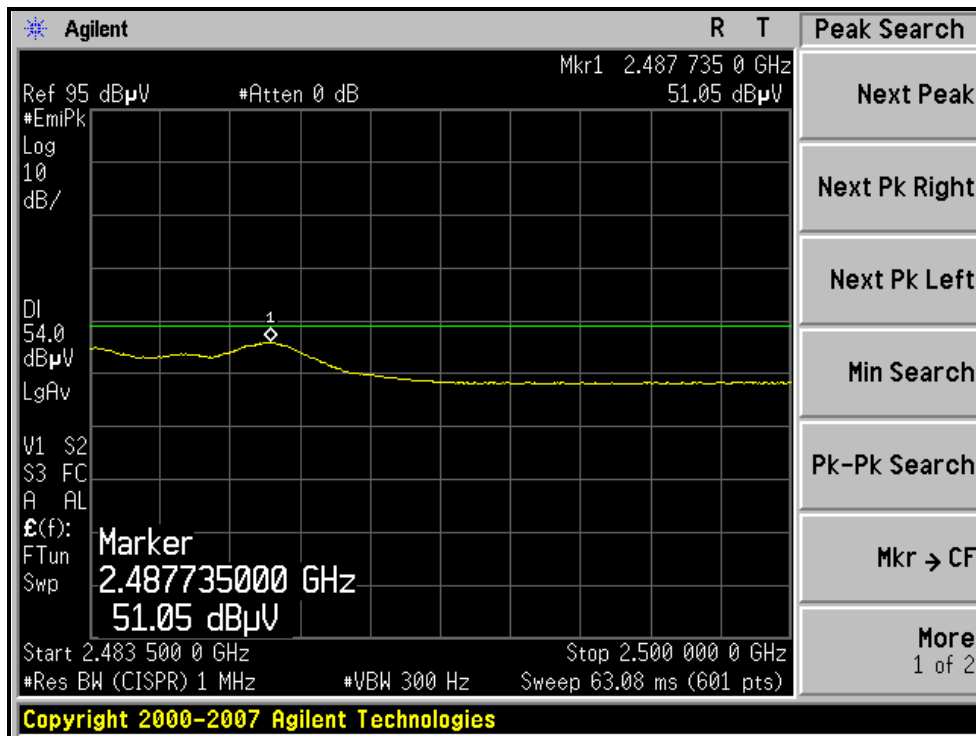
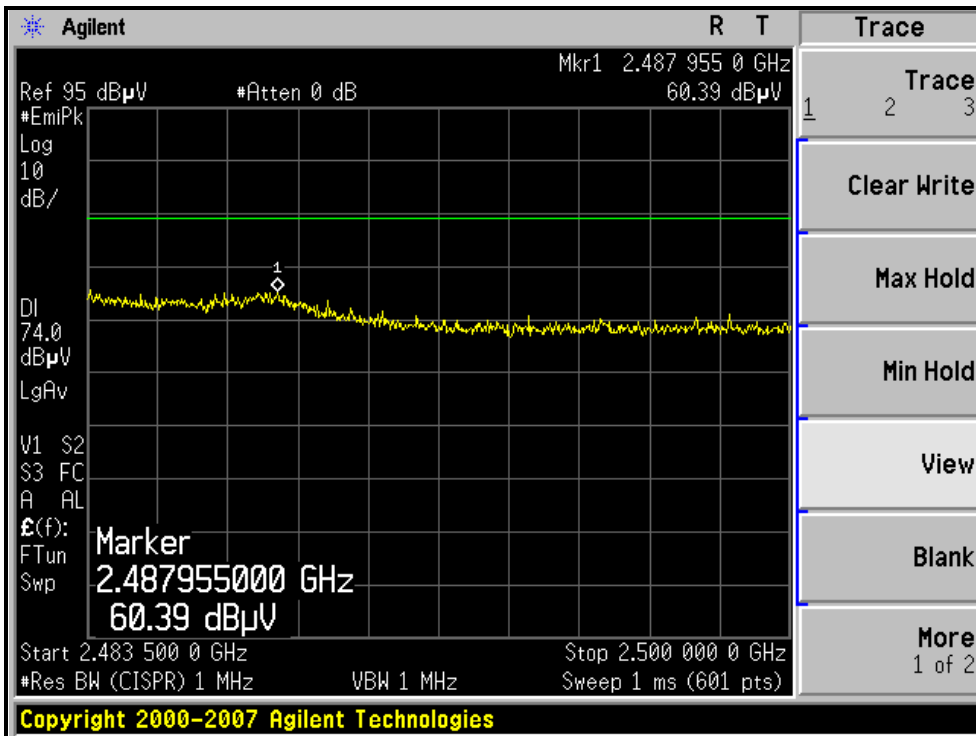

RESTRICTED BANDEDGE (802.11b MODE, CH11, VERTICAL)

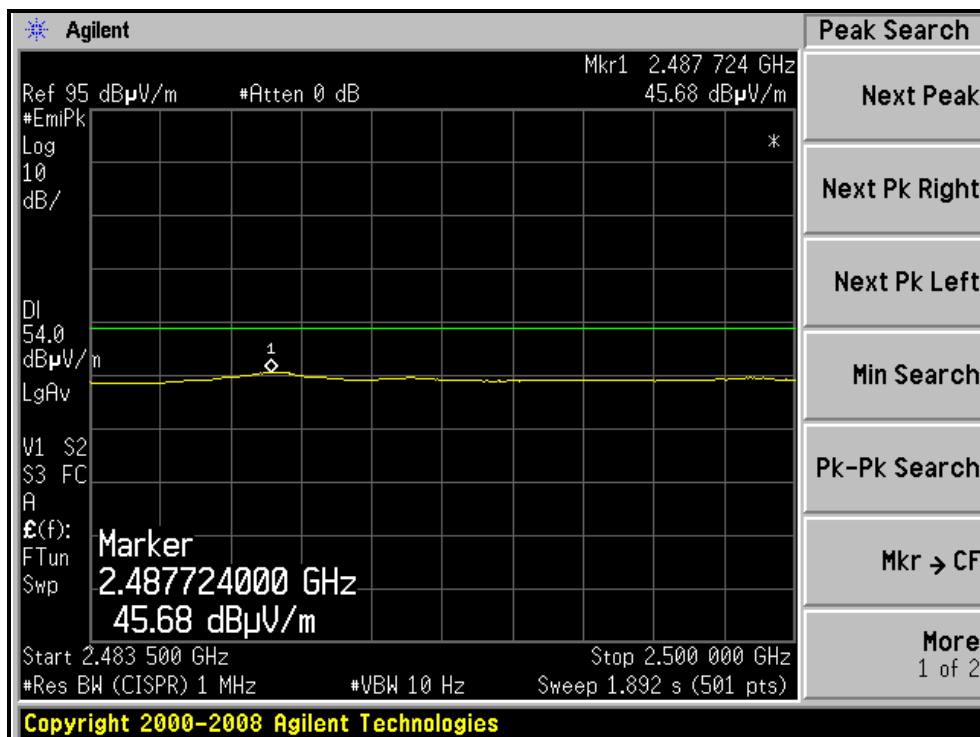
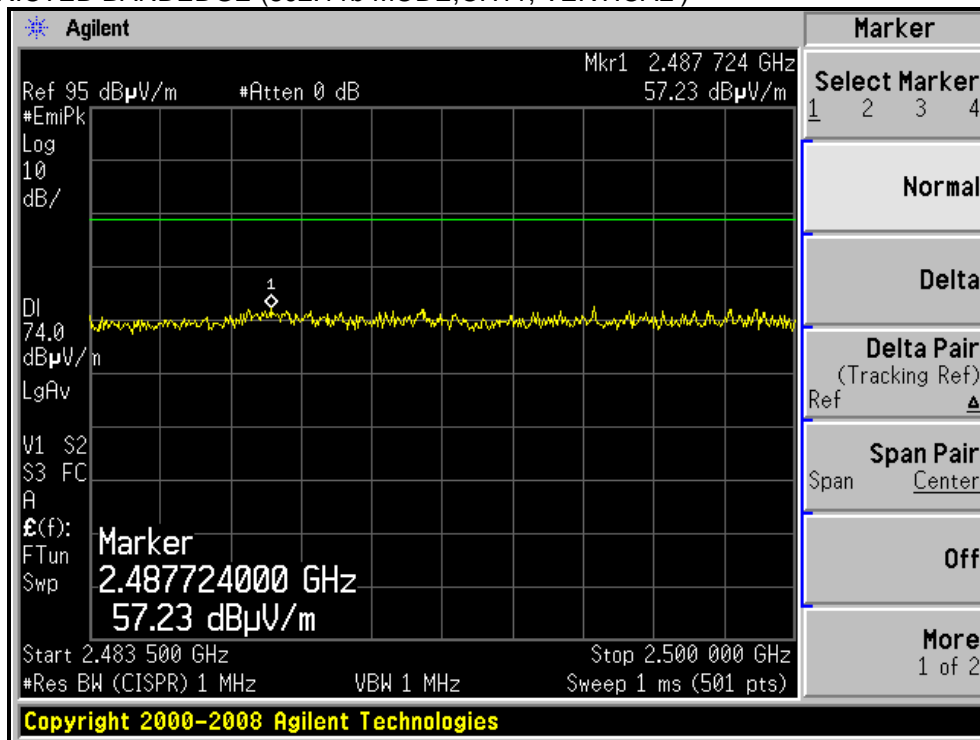



A D T

802.11g OFDM MODULATION

EUT TEST CONDITION		MEASUREMENT DETAIL	
CHANNEL	Channel 1	FREQUENCY RANGE	1 ~ 25GHz
INPUT POWER	120Vac, 60 Hz	DETECTOR FUNCTION	Peak (PK) Average (AV)
ENVIRONMENTAL CONDITIONS	22deg. C, 66%RH 1022 hPa	TESTED BY	Evan Huang

ANTENNA POLARITY & TEST DISTANCE: HORIZONTAL AT 3 M

NO.	FREQ. (MHz)	EMISSION LEVEL (dBuV/m)	LIMIT (dBuV/m)	MARGIN (dB)	ANTENNA HEIGHT (m)	TABLE ANGLE (Degree)	RAW VALUE (dBuV)	CORRECTION FACTOR (dB/m)
1	2390.00	71.3 PK	74.0	-2.7	1.18 H	356	39.64	31.66
2	2390.00	53.1 AV	54.0	-0.9	1.18 H	356	21.44	31.66
3	*2412.00	114.4 PK			1.39 H	348	82.67	31.73
4	*2412.00	104.3 AV			1.39 H	348	72.57	31.73
5	4824.00	60.8 PK	74.0	-13.2	1.26 H	307	21.83	38.97
6	4824.00	47.8 AV	54.0	-6.2	1.26 H	307	8.83	38.97

ANTENNA POLARITY & TEST DISTANCE: VERTICAL AT 3 M

NO.	FREQ. (MHz)	EMISSION LEVEL (dBuV/m)	LIMIT (dBuV/m)	MARGIN (dB)	ANTENNA HEIGHT (m)	TABLE ANGLE (Degree)	RAW VALUE (dBuV)	CORRECTION FACTOR (dB/m)
1	2390.00	61.6 PK	74.0	-12.4	1.00 V	203	29.94	31.66
2	2390.00	47.5 AV	54.0	-6.5	1.00 V	203	15.84	31.66
3	*2412.00	107.1 PK			1.00 V	203	75.37	31.73
4	*2412.00	97.2 AV			1.00 V	203	65.47	31.73
5	4824.00	56.1 PK	74.0	-17.9	1.02 V	214	17.13	38.97
6	4824.00	35.2 AV	54.0	-18.8	1.02 V	214	-3.77	38.97

- REMARKS:**
1. Emission level (dBuV/m) = Raw Value (dBuV) + Correction Factor (dB/m).
 2. Correction Factor (dB/m) = Antenna Factor (dB/m) + Cable Factor (dB).
 3. The other emission levels were very low against the limit.
 4. Margin value = Emission level – Limit value.
 5. “ * “: Fundamental frequency.



A D T

EUT TEST CONDITION		MEASUREMENT DETAIL	
CHANNEL	Channel 6	FREQUENCY RANGE	1 ~ 25GHz
INPUT POWER	120Vac, 60 Hz	DETECTOR FUNCTION	Peak (PK) Average (AV)
ENVIRONMENTAL CONDITIONS	22deg. C, 66%RH 1022 hPa	TESTED BY	Evan Huang

ANTENNA POLARITY & TEST DISTANCE: HORIZONTAL AT 3 M

NO.	FREQ. (MHz)	EMISSION LEVEL (dBuV/m)	LIMIT (dBuV/m)	MARGIN (dB)	ANTENNA HEIGHT (m)	TABLE ANGLE (Degree)	RAW VALUE (dBuV)	CORRECTION FACTOR (dB/m)
1	*2437.00	116.2 PK			1.08 H	346	84.39	31.81
2	*2437.00	106.5 AV			1.08 H	346	74.69	31.81
3	2484.90	62.7 PK	74.0	-11.3	1.39 H	349	30.73	31.97
4	2484.90	52.9 AV	54.0	-1.1	1.39 H	349	20.93	31.97
5	2489.20	63.0 PK	74.0	-11.0	1.07 H	343	31.02	31.98
6	2489.20	52.9 AV	54.0	-1.1	1.07 H	343	20.92	31.98
7	4874.00	60.3 PK	74.0	-13.7	1.21 H	304	21.16	39.14
8	4874.00	47.4 AV	54.0	-6.6	1.21 H	304	8.26	39.14
9	7311.00	56.9 PK	74.0	-17.1	1.14 H	281	10.27	46.63
10	7311.00	39.4 AV	54.0	-14.6	1.14 H	281	-7.23	46.63

ANTENNA POLARITY & TEST DISTANCE: VERTICAL AT 3 M

NO.	FREQ. (MHz)	EMISSION LEVEL (dBuV/m)	LIMIT (dBuV/m)	MARGIN (dB)	ANTENNA HEIGHT (m)	TABLE ANGLE (Degree)	RAW VALUE (dBuV)	CORRECTION FACTOR (dB/m)
1	*2437.00	109.3 PK			1.00 V	217	77.49	31.81
2	*2437.00	99.2 AV			1.00 V	217	67.39	31.81
3	4874.00	56.4 PK	74.0	-17.6	1.34 V	236	17.26	39.14
4	4874.00	35.4 AV	54.0	-18.6	1.34 V	236	-3.74	39.14
5	7311.00	57.4 PK	74.0	-16.6	1.21 V	63	10.77	46.63
6	7311.00	39.2 AV	54.0	-14.8	1.21 V	63	-7.43	46.63

- REMARKS:**
1. Emission level (dBuV/m) = Raw Value (dBuV) + Correction Factor (dB/m).
 2. Correction Factor (dB/m) = Antenna Factor (dB/m) + Cable Factor (dB).
 3. The other emission levels were very low against the limit.
 4. Margin value = Emission level – Limit value.
 5. “ * ”: Fundamental frequency.



A D T

EUT TEST CONDITION		MEASUREMENT DETAIL	
CHANNEL	Channel 11	FREQUENCY RANGE	1 ~ 25GHz
INPUT POWER	120Vac, 60 Hz	DETECTOR FUNCTION	Peak (PK) Average (AV)
ENVIRONMENTAL CONDITIONS	22deg. C, 66%RH 1022 hPa	TESTED BY	Evan Huang

ANTENNA POLARITY & TEST DISTANCE: HORIZONTAL AT 3 M

NO.	FREQ. (MHz)	EMISSION LEVEL (dBuV/m)	LIMIT (dBuV/m)	MARGIN (dB)	ANTENNA HEIGHT (m)	TABLE ANGLE (Degree)	RAW VALUE (dBuV)	CORRECTION FACTOR (dB/m)
1	*2462.00	111.5 PK			1.39 H	341	79.61	31.89
2	*2462.00	101.4 AV			1.39 H	341	69.51	31.89
3	2483.50	70.3 PK	74.0	-3.7	1.09 H	348	38.33	31.97
4	2483.50	53.4 AV	54.0	-0.6	1.09 H	348	21.43	31.97
5	4924.00	60.4 PK	74.0	-13.6	1.24 H	301	21.09	39.31
6	4924.00	47.2 AV	54.0	-6.8	1.24 H	301	7.89	39.31
7	7386.00	57.2 PK	74.0	-16.8	1.13 H	284	10.60	46.60
8	7386.00	39.7 AV	54.0	-14.3	1.13 H	284	-6.90	46.60

ANTENNA POLARITY & TEST DISTANCE: VERTICAL AT 3 M

NO.	FREQ. (MHz)	EMISSION LEVEL (dBuV/m)	LIMIT (dBuV/m)	MARGIN (dB)	ANTENNA HEIGHT (m)	TABLE ANGLE (Degree)	RAW VALUE (dBuV)	CORRECTION FACTOR (dB/m)
1	*2462.00	104.1 PK			1.00 V	219	72.21	31.89
2	*2462.00	94.5 AV			1.00 V	219	62.61	31.89
3	2483.50	65.3 PK	74.0	-8.7	1.00 V	219	33.33	31.97
4	2483.50	50.3 AV	54.0	-3.7	1.00 V	219	18.33	31.97
5	4924.00	56.1 PK	74.0	-17.9	1.29 V	231	16.79	39.31
6	4924.00	35.3 AV	54.0	-18.7	1.29 V	231	-4.01	39.31
7	7386.00	57.1 PK	74.0	-16.9	1.24 V	59	10.50	46.60
8	7386.00	39.4 AV	54.0	-14.6	1.24 V	59	-7.20	46.60

- REMARKS:**
1. Emission level (dBuV/m) = Raw Value (dBuV) + Correction Factor (dB/m).
 2. Correction Factor (dB/m) = Antenna Factor (dB/m) + Cable Factor (dB).
 3. The other emission levels were very low against the limit.
 4. Margin value = Emission level – Limit value.
 5. “ * “: Fundamental frequency.



A D T

RESTRICTED BANDEDGE (802.11g MODE, CH1, HORIZONTAL)

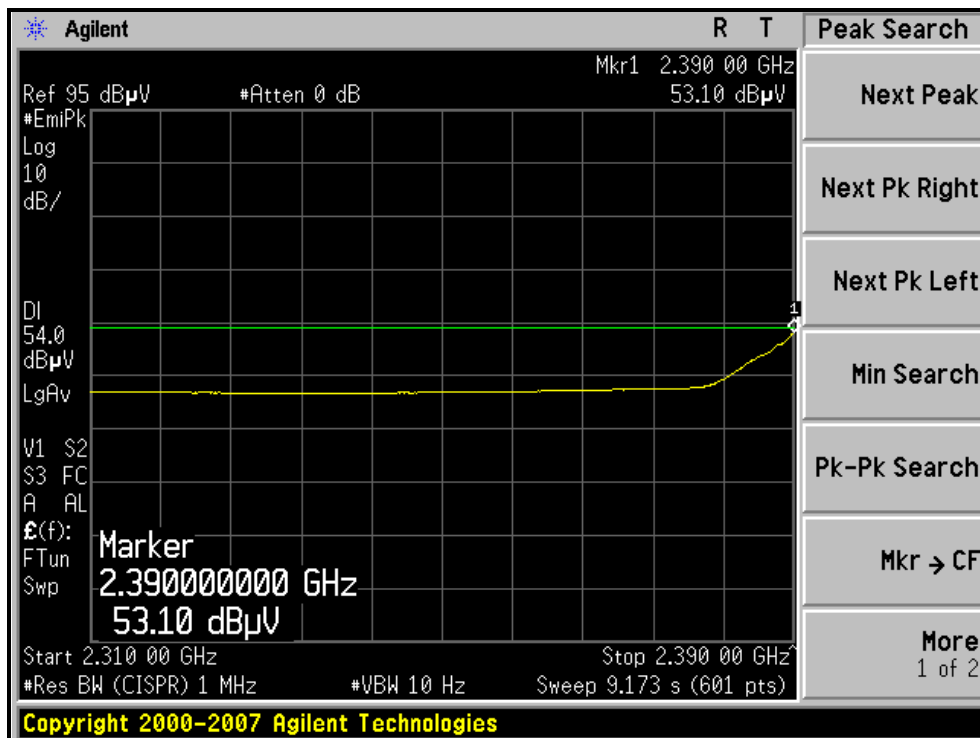
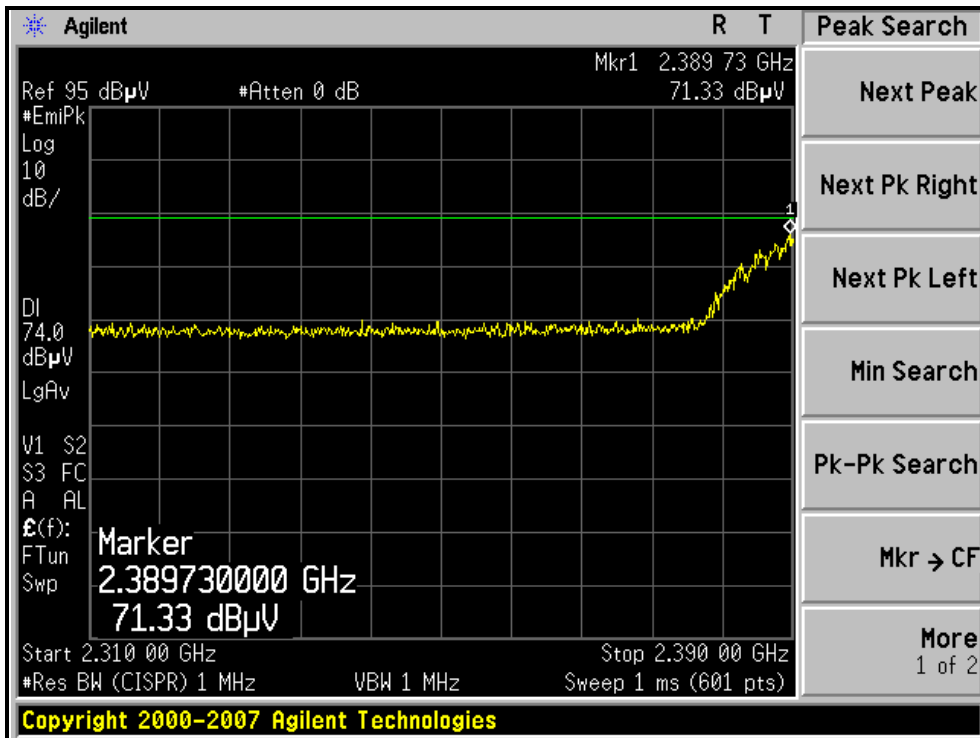



A D T

RESTRICTED BANDEDGE (802.11g MODE,CH1, VERTICAL)

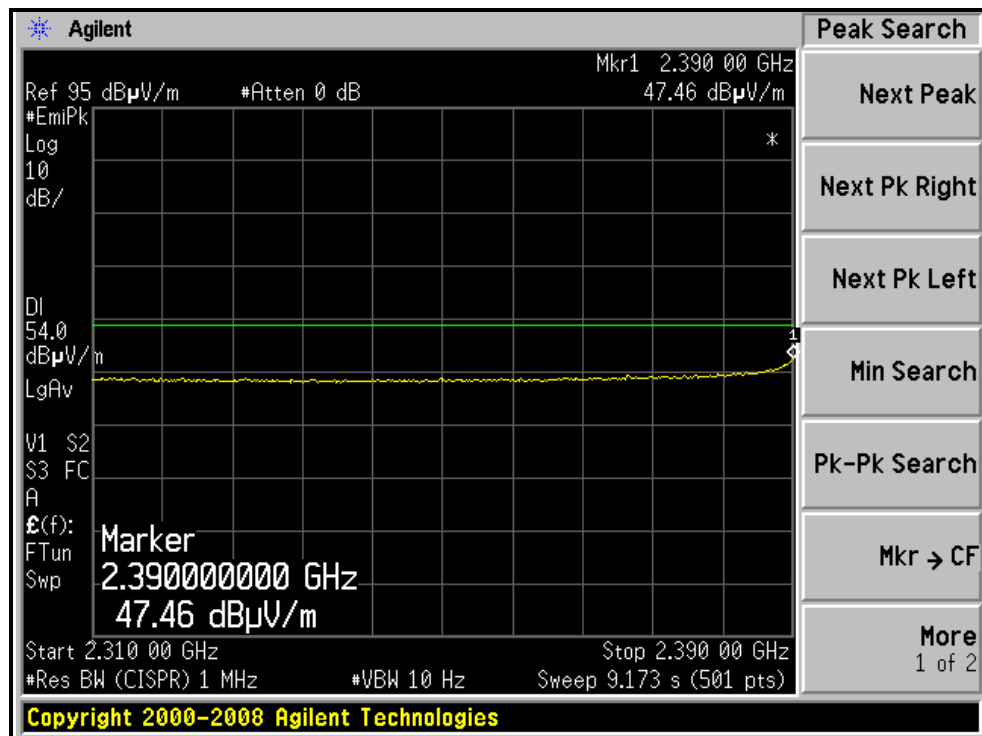
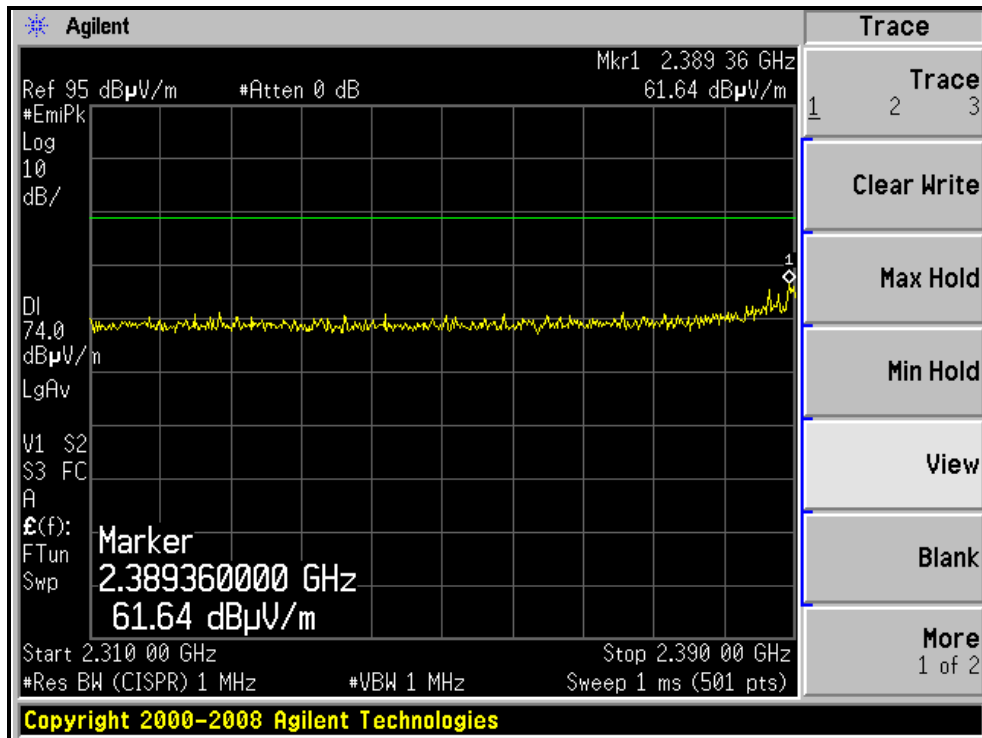



A D T

RESTRICTED BANDEDGE (802.11g MODE, CH11, HORIZONTAL)

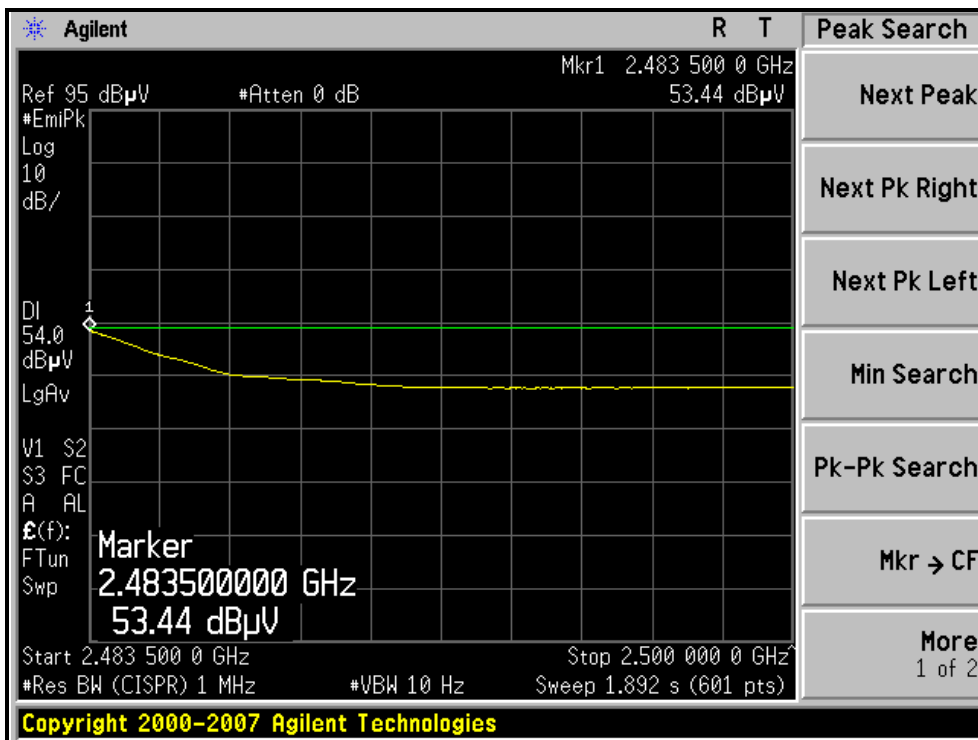
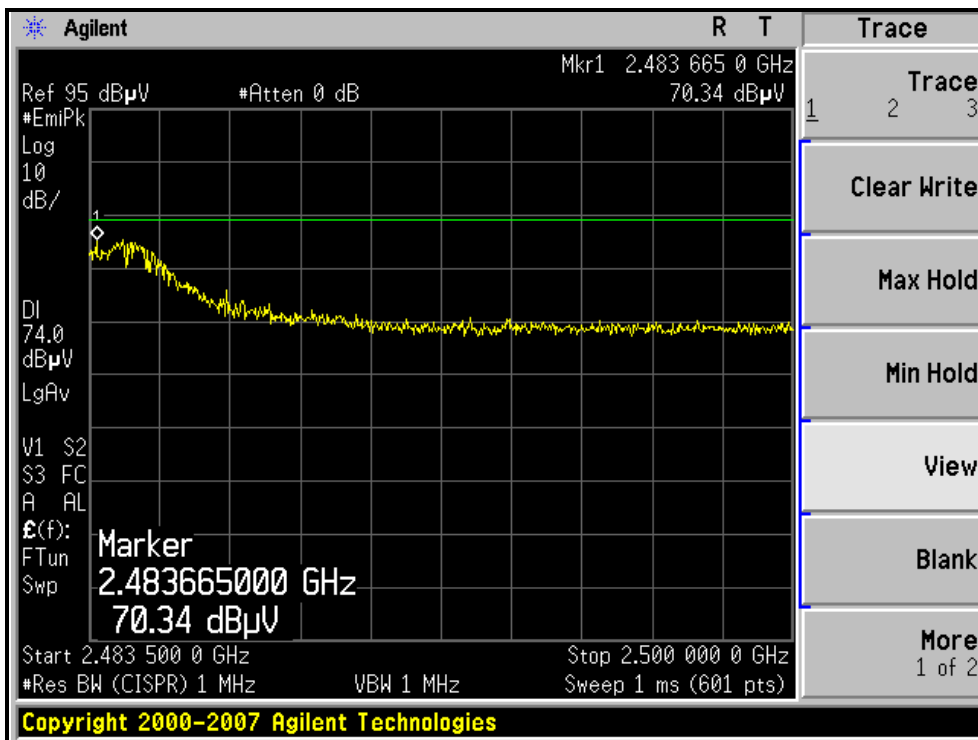



A D T

RESTRICTED BANDEDGE (802.11g MODE, CH11, VERTICAL)

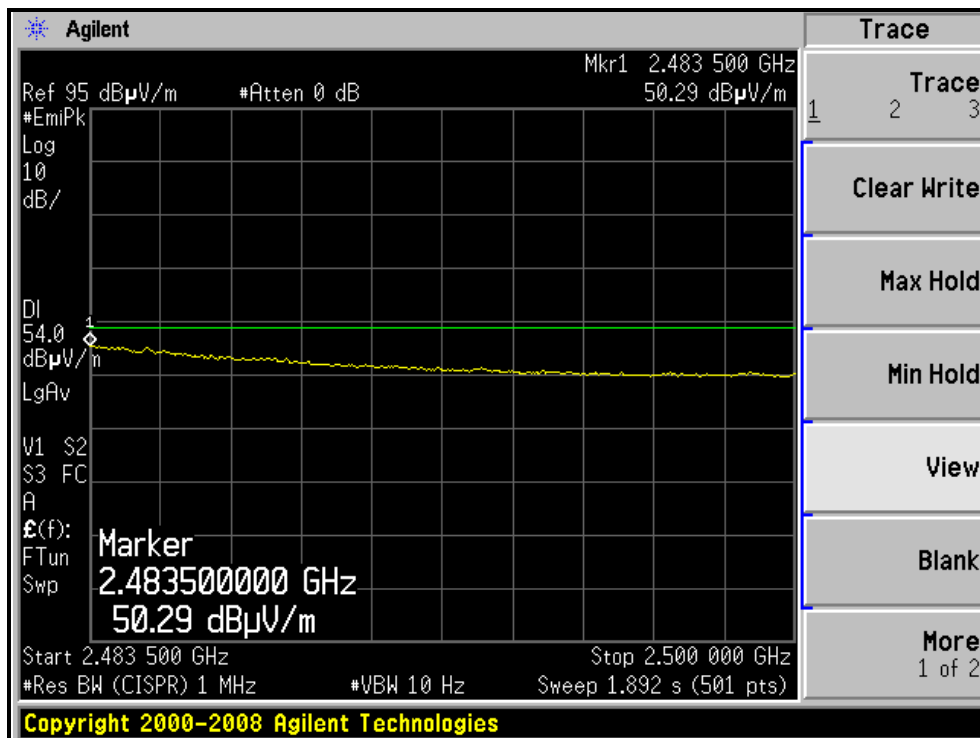
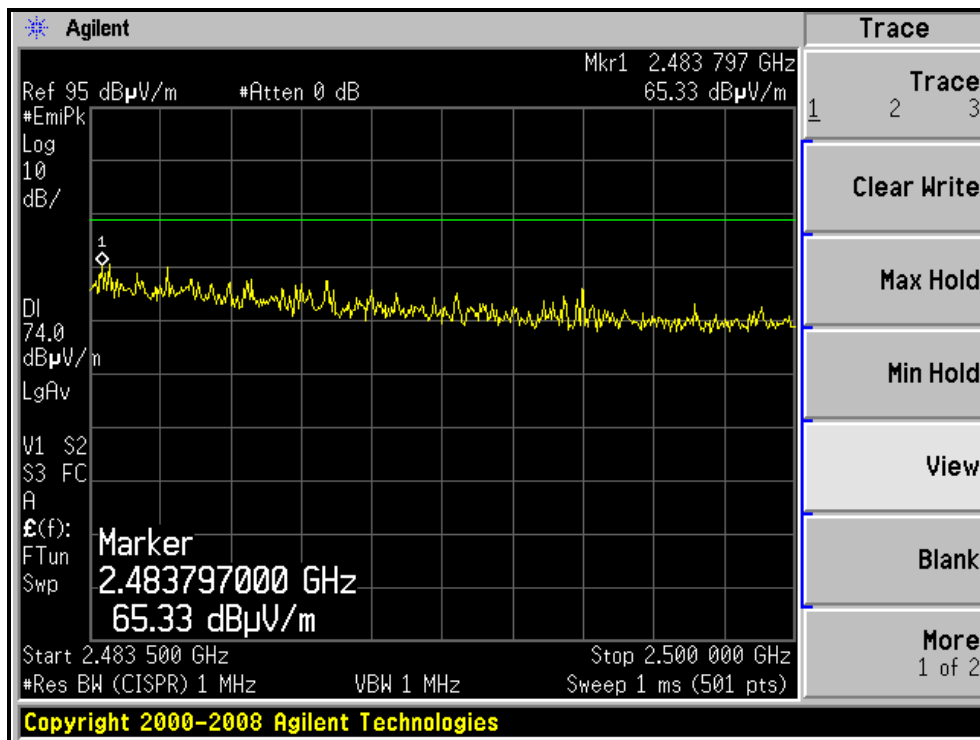



A D T

802.11n (20MHz) OFDM MODULATION

EUT TEST CONDITION		MEASUREMENT DETAIL	
CHANNEL	Channel 1	FREQUENCY RANGE	1 ~ 25GHz
INPUT POWER	120Vac, 60 Hz	DETECTOR FUNCTION	Peak (PK) Average (AV)
ENVIRONMENTAL CONDITIONS	22deg. C, 66%RH 1022 hPa	TESTED BY	Evan Huang

ANTENNA POLARITY & TEST DISTANCE: HORIZONTAL AT 3 M

NO.	FREQ. (MHz)	EMISSION LEVEL (dBuV/m)	LIMIT (dBuV/m)	MARGIN (dB)	ANTENNA HEIGHT (m)	TABLE ANGLE (Degree)	RAW VALUE (dBuV)	CORRECTION FACTOR (dB/m)
1	2390.00	73.1 PK	74.0	-0.9	1.18 H	0	41.44	31.66
2	2390.00	49.5 AV	54.0	-4.5	1.18 H	0	17.84	31.66
3	*2412.00	111.4 PK			1.37 H	352	79.67	31.73
4	*2412.00	101.9 AV			1.37 H	352	70.17	31.73
5	4824.00	59.4 PK	74.0	-14.6	1.21 H	304	20.43	38.97
6	4824.00	46.1 AV	54.0	-7.9	1.21 H	304	7.13	38.97

ANTENNA POLARITY & TEST DISTANCE: VERTICAL AT 3 M

NO.	FREQ. (MHz)	EMISSION LEVEL (dBuV/m)	LIMIT (dBuV/m)	MARGIN (dB)	ANTENNA HEIGHT (m)	TABLE ANGLE (Degree)	RAW VALUE (dBuV)	CORRECTION FACTOR (dB/m)
1	2390.00	61.6 PK	74.0	-12.4	1.00 V	211	29.94	31.66
2	2390.00	48.8 AV	54.0	-5.2	1.00 V	211	17.14	31.66
3	*2412.00	104.6 PK			1.00 V	211	72.87	31.73
4	*2412.00	94.2 AV			1.00 V	211	62.47	31.73
5	4824.00	57.2 PK	74.0	-16.8	1.29 V	231	18.23	38.97
6	4824.00	36.3 AV	54.0	-17.7	1.29 V	231	-2.67	38.97

- REMARKS:**
1. Emission level (dBuV/m) = Raw Value (dBuV) + Correction Factor (dB/m).
 2. Correction Factor (dB/m) = Antenna Factor (dB/m) + Cable Factor (dB).
 3. The other emission levels were very low against the limit.
 4. Margin value = Emission level – Limit value.
 5. “ * “: Fundamental frequency.



A D T

EUT TEST CONDITION		MEASUREMENT DETAIL	
CHANNEL	Channel 6	FREQUENCY RANGE	1 ~ 25GHz
INPUT POWER	120Vac, 60 Hz	DETECTOR FUNCTION	Peak (PK) Average (AV)
ENVIRONMENTAL CONDITIONS	22deg. C, 66%RH 1022 hPa	TESTED BY	Evan Huang

ANTENNA POLARITY & TEST DISTANCE: HORIZONTAL AT 3 M

NO.	FREQ. (MHz)	EMISSION LEVEL (dBuV/m)	LIMIT (dBuV/m)	MARGIN (dB)	ANTENNA HEIGHT (m)	TABLE ANGLE (Degree)	RAW VALUE (dBuV)	CORRECTION FACTOR (dB/m)
1	2385.40	62.0 PK	74.0	-12.0	1.19 H	346	30.36	31.64
2	2385.40	52.7 AV	54.0	-1.3	1.19 H	346	21.06	31.64
3	*2437.00	116.0 PK			1.09 H	349	84.19	31.81
4	*2437.00	105.4 AV			1.09 H	349	73.59	31.81
5	2488.50	62.8 PK	74.0	-11.2	1.07 H	345	30.82	31.98
6	2488.50	53.0 AV	54.0	-1.0	1.07 H	345	21.02	31.98
7	4874.00	60.2 PK	74.0	-13.8	1.24 H	309	21.06	39.14
8	4874.00	46.7 AV	54.0	-7.3	1.24 H	309	7.56	39.14
9	7311.00	57.2 PK	74.0	-16.8	1.13 H	284	10.57	46.63
10	7311.00	39.6 AV	54.0	-14.4	1.13 H	284	-7.03	46.63

ANTENNA POLARITY & TEST DISTANCE: VERTICAL AT 3 M

NO.	FREQ. (MHz)	EMISSION LEVEL (dBuV/m)	LIMIT (dBuV/m)	MARGIN (dB)	ANTENNA HEIGHT (m)	TABLE ANGLE (Degree)	RAW VALUE (dBuV)	CORRECTION FACTOR (dB/m)
1	*2437.00	108.2 PK			1.00 V	219	76.39	31.81
2	*2437.00	98.3 AV			1.00 V	219	66.49	31.81
3	4874.00	56.9 PK	74.0	-17.1	1.31 V	234	17.76	39.14
4	4874.00	35.9 AV	54.0	-18.1	1.31 V	234	-3.24	39.14
5	7311.00	57.6 PK	74.0	-16.4	1.24 V	73	10.97	46.63
6	7311.00	39.1 AV	54.0	-14.9	1.24 V	73	-7.53	46.63

- REMARKS:**
1. Emission level (dBuV/m) = Raw Value (dBuV) + Correction Factor (dB/m).
 2. Correction Factor (dB/m) = Antenna Factor (dB/m) + Cable Factor (dB).
 3. The other emission levels were very low against the limit.
 4. Margin value = Emission level – Limit value.
 5. “ * “: Fundamental frequency.



A D T

EUT TEST CONDITION		MEASUREMENT DETAIL	
CHANNEL	Channel 11	FREQUENCY RANGE	1 ~ 25GHz
INPUT POWER	120Vac, 60 Hz	DETECTOR FUNCTION	Peak (PK) Average (AV)
ENVIRONMENTAL CONDITIONS	22deg. C, 66%RH 1022 hPa	TESTED BY	Evan Huang

ANTENNA POLARITY & TEST DISTANCE: HORIZONTAL AT 3 M

NO.	FREQ. (MHz)	EMISSION LEVEL (dBuV/m)	LIMIT (dBuV/m)	MARGIN (dB)	ANTENNA HEIGHT (m)	TABLE ANGLE (Degree)	RAW VALUE (dBuV)	CORRECTION FACTOR (dB/m)
1	*2462.00	108.4 PK			1.32 H	351	76.51	31.89
2	*2462.00	97.8 AV			1.32 H	351	65.91	31.89
3	2483.50	71.1 PK	74.0	-2.9	1.09 H	350	39.13	31.97
4	2483.50	53.4 AV	54.0	-0.6	1.09 H	350	21.43	31.97
5	4924.00	56.3 PK	74.0	-17.7	1.24 H	307	16.99	39.31
6	4924.00	43.1 AV	54.0	-10.9	1.24 H	307	3.79	39.31
7	7386.00	57.0 PK	74.0	-17.0	1.10 H	243	10.40	46.60
8	7386.00	39.7 AV	54.0	-14.3	1.10 H	243	-6.90	46.60

ANTENNA POLARITY & TEST DISTANCE: VERTICAL AT 3 M

NO.	FREQ. (MHz)	EMISSION LEVEL (dBuV/m)	LIMIT (dBuV/m)	MARGIN (dB)	ANTENNA HEIGHT (m)	TABLE ANGLE (Degree)	RAW VALUE (dBuV)	CORRECTION FACTOR (dB/m)
1	*2462.00	100.7 PK			1.00 V	253	68.81	31.89
2	*2462.00	90.6 AV			1.00 V	253	58.71	31.89
3	2483.50	66.8 PK	74.0	-7.2	1.00 V	253	34.83	31.97
4	2483.50	50.5 AV	54.0	-3.5	1.00 V	253	18.53	31.97
5	4924.00	54.2 PK	74.0	-19.8	1.29 V	234	14.89	39.31
6	4924.00	33.2 AV	54.0	-20.8	1.29 V	234	-6.11	39.31
7	7386.00	57.9 PK	74.0	-16.1	1.21 V	64	11.30	46.60
8	7386.00	39.3 AV	54.0	-14.7	1.21 V	64	-7.30	46.60

- REMARKS:**
1. Emission level (dBuV/m) = Raw Value (dBuV) + Correction Factor (dB/m).
 2. Correction Factor (dB/m) = Antenna Factor (dB/m) + Cable Factor (dB).
 3. The other emission levels were very low against the limit.
 4. Margin value = Emission level – Limit value.
 5. “ * “: Fundamental frequency.



A D T

RESTRICTED BANDEDGE (802.11n (20MHz) MODE,CH1, HORIZONTAL)

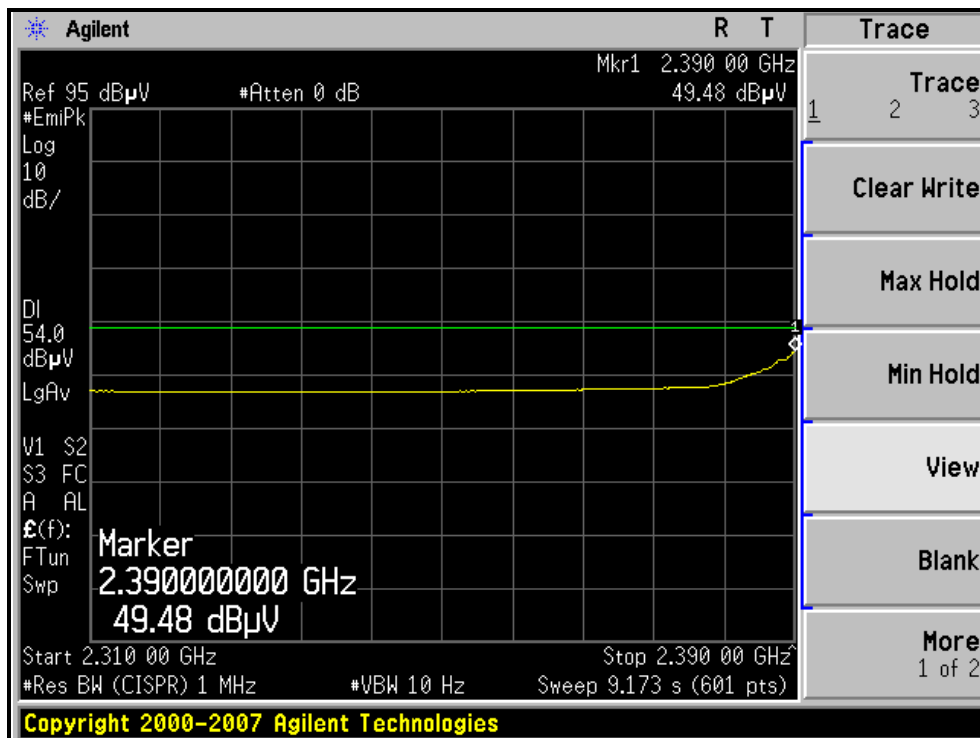
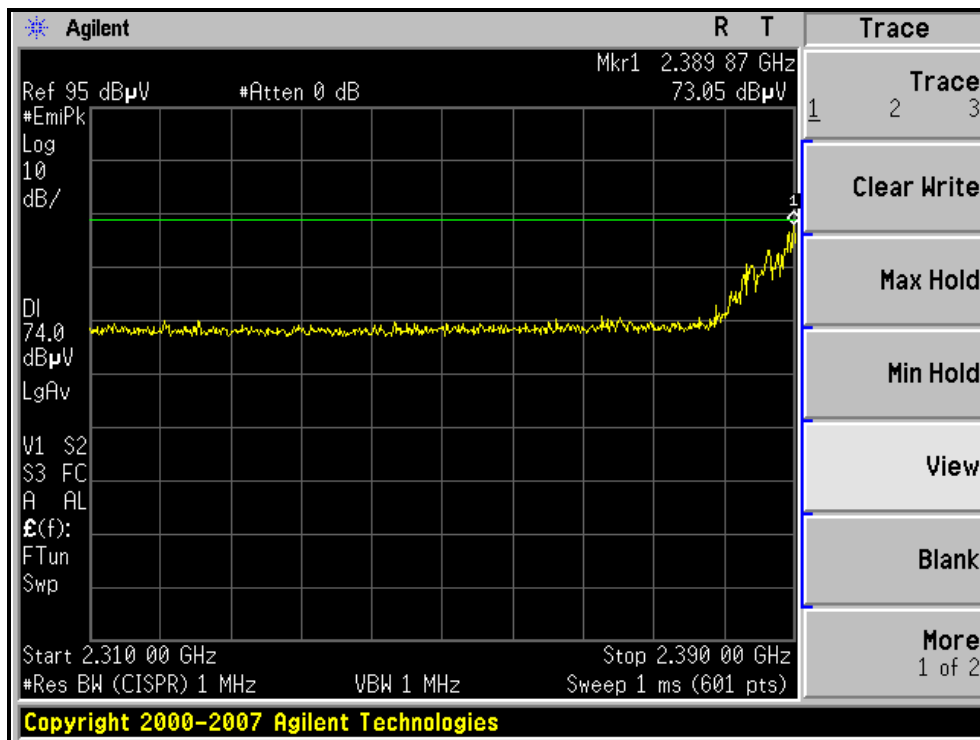



A D T

RESTRICTED BANDEDGE (802.11n (20MHz) MODE,CH1, VERTICAL)

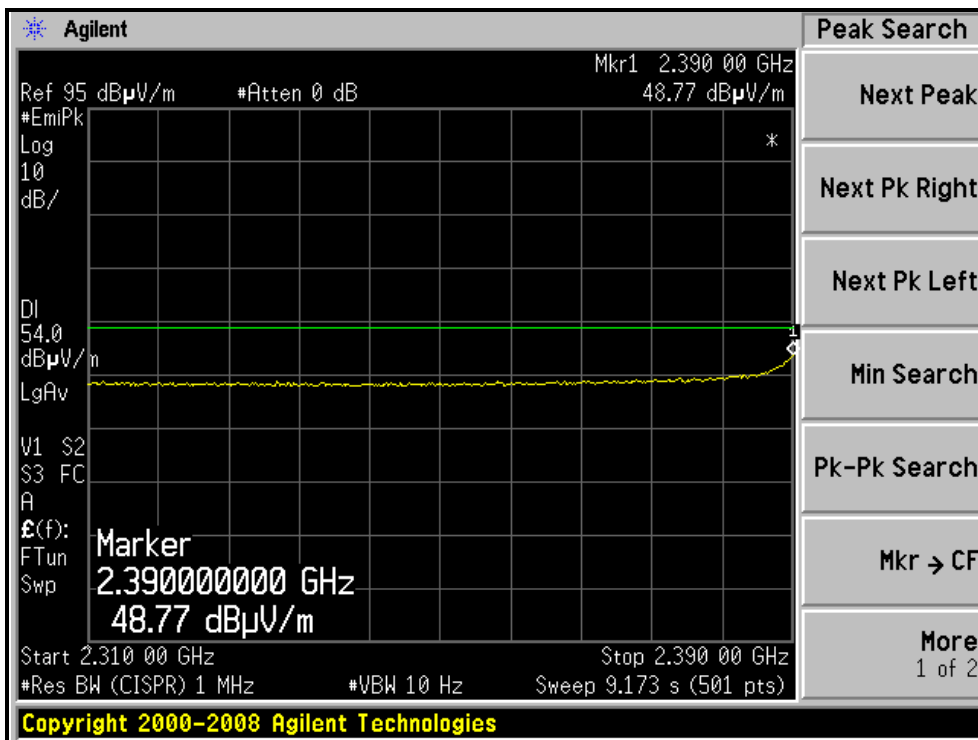
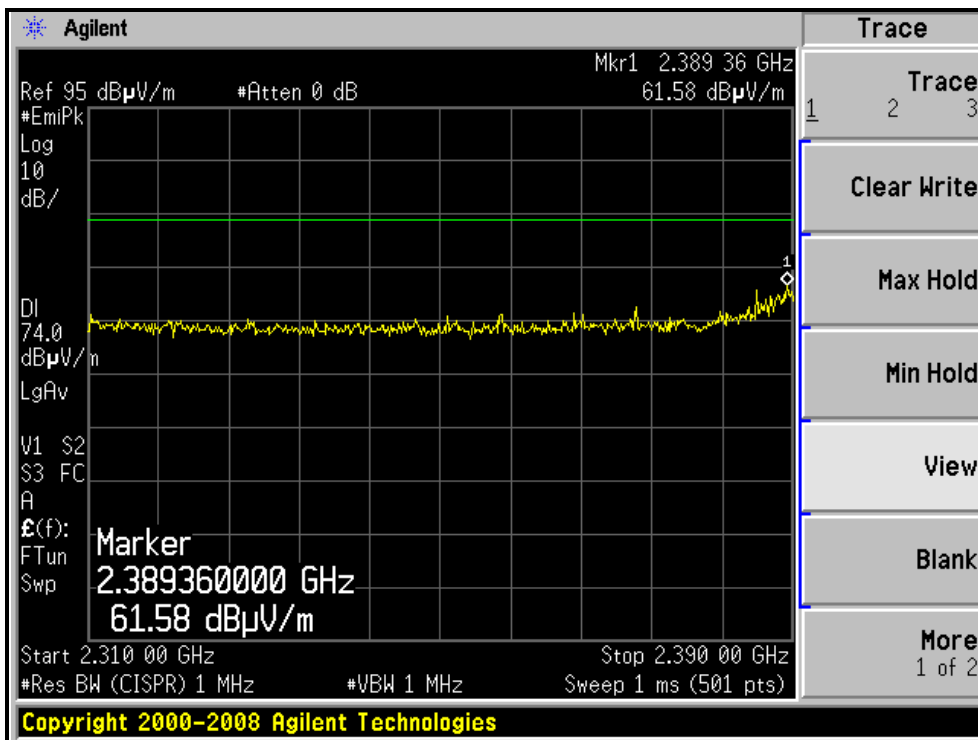



A D T

RESTRICTED BANDEDGE (802.11n (20MHz) MODE,CH11, HORIZONTAL)

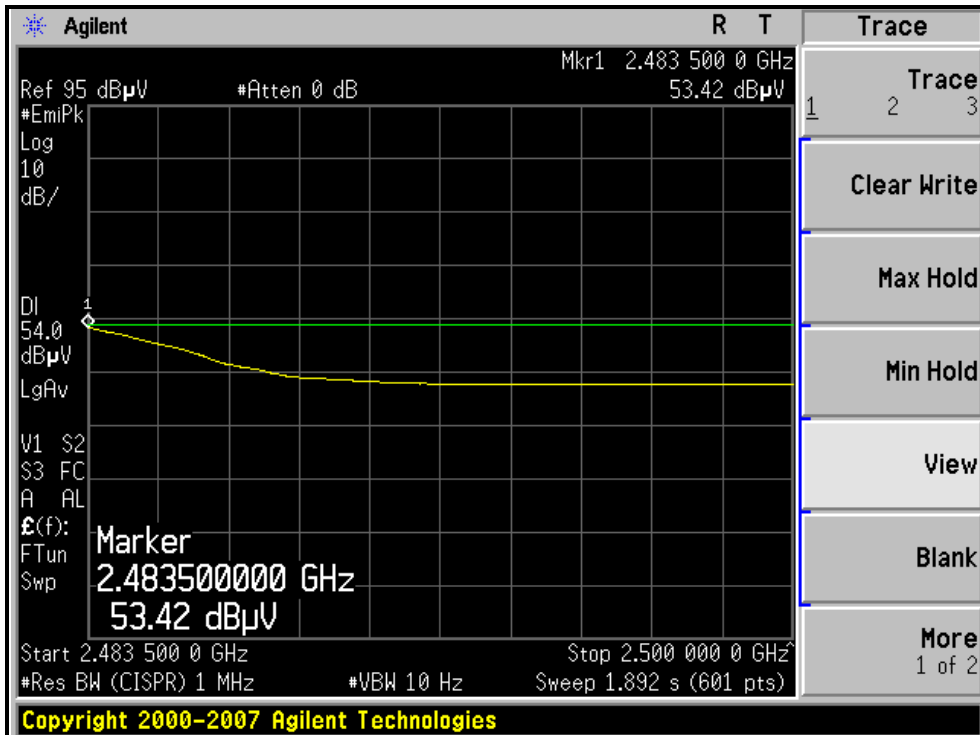
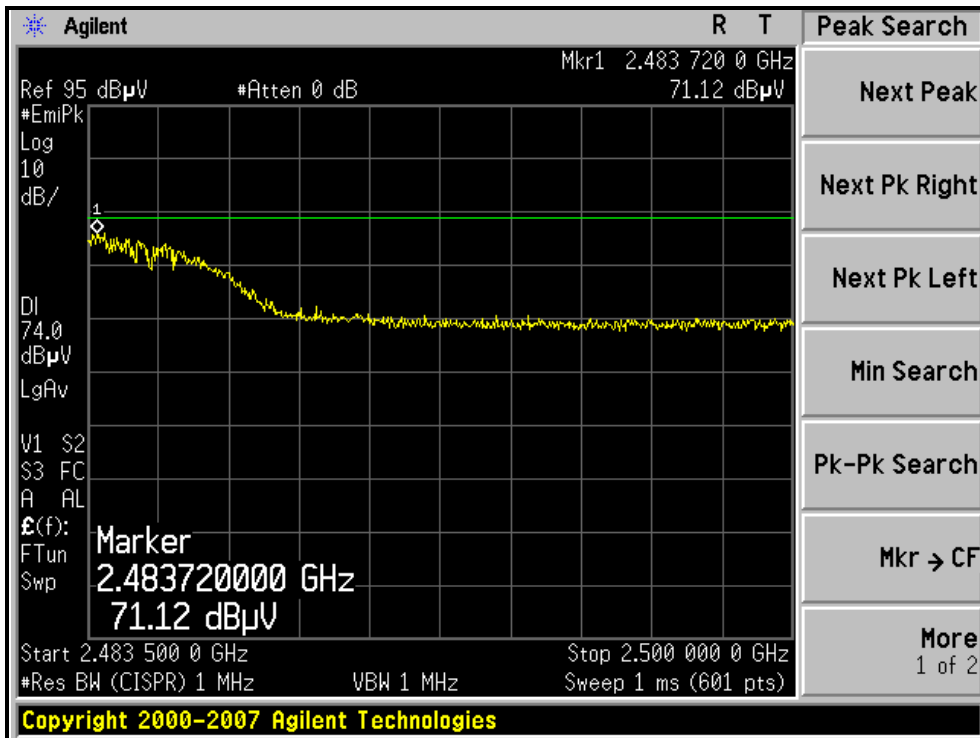



A D T

RESTRICTED BANDEDGE (802.11n (20MHz) MODE,CH11, VERTICAL)

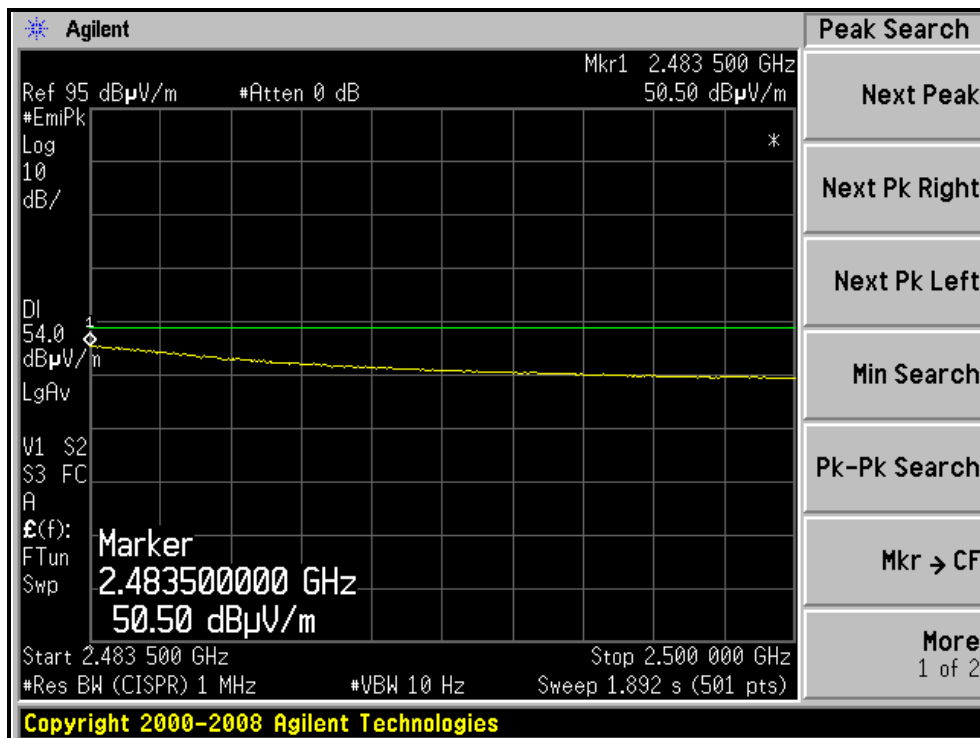
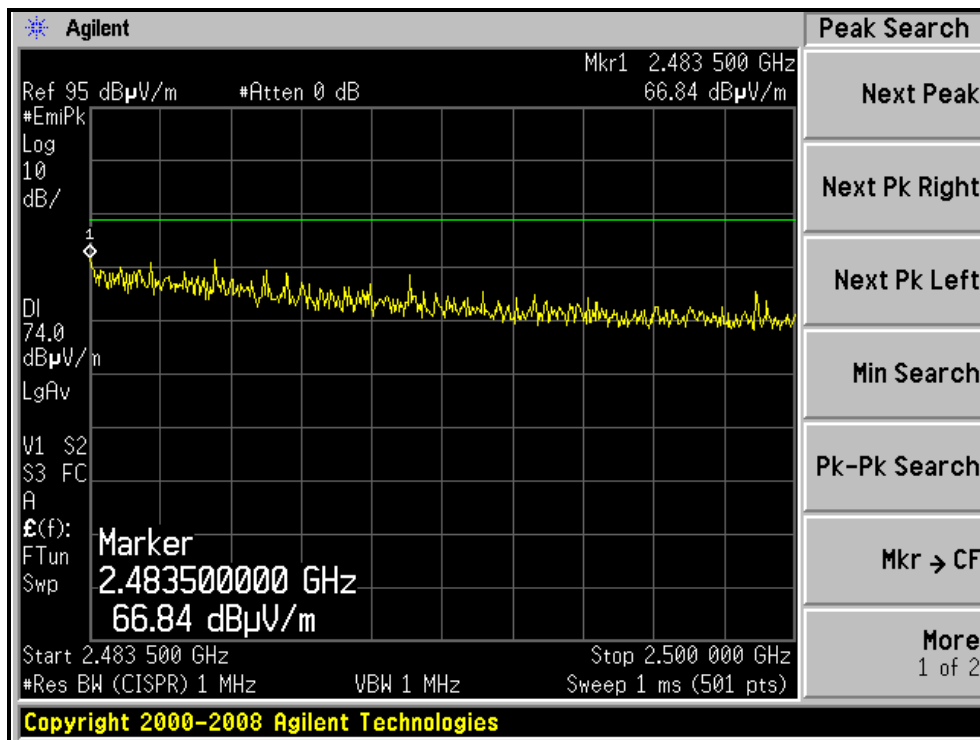



A D T

802.11n (40MHz) OFDM MODULATION

EUT TEST CONDITION		MEASUREMENT DETAIL	
CHANNEL	Channel 3	FREQUENCY RANGE	1 ~ 25GHz
INPUT POWER	120Vac, 60 Hz	DETECTOR FUNCTION	Peak (PK) Average (AV)
ENVIRONMENTAL CONDITIONS	22deg. C, 66%RH 1022 hPa	TESTED BY	Evan Huang

ANTENNA POLARITY & TEST DISTANCE: HORIZONTAL AT 3 M

NO.	FREQ. (MHz)	EMISSION LEVEL (dBuV/m)	LIMIT (dBuV/m)	MARGIN (dB)	ANTENNA HEIGHT (m)	TABLE ANGLE (Degree)	RAW VALUE (dBuV)	CORRECTION FACTOR (dB/m)
1	2390.00	68.5 PK	74.0	-5.5	1.19 H	0	36.84	31.66
2	2390.00	52.5 AV	54.0	-1.5	1.19 H	0	20.84	31.66
3	*2422.00	102.6 PK			1.09 H	320	70.84	31.76
4	*2422.00	93.6 AV			1.09 H	320	61.84	31.76
5	4844.00	59.2 PK	74.0	-14.8	1.03 H	307	20.16	39.04
6	4844.00	44.3 AV	54.0	-9.7	1.03 H	307	5.26	39.04
7	7266.00	57.4 PK	74.0	-16.6	1.00 H	102	10.73	46.67
8	7266.00	39.1 AV	54.0	-14.9	1.00 H	102	-7.57	46.67

ANTENNA POLARITY & TEST DISTANCE: VERTICAL AT 3 M

NO.	FREQ. (MHz)	EMISSION LEVEL (dBuV/m)	LIMIT (dBuV/m)	MARGIN (dB)	ANTENNA HEIGHT (m)	TABLE ANGLE (Degree)	RAW VALUE (dBuV)	CORRECTION FACTOR (dB/m)
1	2390.00	58.7 PK	74.0	-15.3	1.00 V	263	27.04	31.66
2	2390.00	47.2 AV	54.0	-6.8	1.00 V	263	15.54	31.66
3	*2422.00	95.2 PK			1.04 V	273	63.44	31.76
4	*2422.00	85.4 AV			1.04 V	273	53.64	31.76
5	4844.00	56.2 PK	74.0	-17.8	1.29 V	213	17.16	39.04
6	4844.00	35.1 AV	54.0	-18.9	1.29 V	213	-3.94	39.04
7	7266.00	57.3 PK	74.0	-16.7	1.24 V	59	10.63	46.67
8	7266.00	39.2 AV	54.0	-14.8	1.24 V	59	-7.47	46.67

- REMARKS:**
1. Emission level (dBuV/m) = Raw Value (dBuV) + Correction Factor (dB/m).
 2. Correction Factor (dB/m) = Antenna Factor (dB/m) + Cable Factor (dB).
 3. The other emission levels were very low against the limit.
 4. Margin value = Emission level – Limit value.
 5. “ * “: Fundamental frequency.



A D T

EUT TEST CONDITION		MEASUREMENT DETAIL	
CHANNEL	Channel 6	FREQUENCY RANGE	1 ~ 25GHz
INPUT POWER	120Vac, 60 Hz	DETECTOR FUNCTION	Peak (PK) Average (AV)
ENVIRONMENTAL CONDITIONS	22deg. C, 66%RH 1022 hPa	TESTED BY	Evan Huang

ANTENNA POLARITY & TEST DISTANCE: HORIZONTAL AT 3 M

NO.	FREQ. (MHz)	EMISSION LEVEL (dBuV/m)	LIMIT (dBuV/m)	MARGIN (dB)	ANTENNA HEIGHT (m)	TABLE ANGLE (Degree)	RAW VALUE (dBuV)	CORRECTION FACTOR (dB/m)
1	2390.00	70.5 PK	74.0	-3.5	1.19 H	0	38.84	31.66
2	2390.00	52.8 AV	54.0	-1.2	1.19 H	0	21.14	31.66
3	*2437.00	109.2 PK			1.08 H	343	77.39	31.81
4	*2437.00	99.7 AV			1.08 H	343	67.89	31.81
5	2483.50	67.0 PK	74.0	-7.0	1.08 H	346	35.03	31.97
6	2483.50	52.7 AV	54.0	-1.3	1.08 H	346	20.73	31.97
7	4874.00	60.7 PK	74.0	-13.3	1.04 H	319	21.56	39.14
8	4874.00	45.7 AV	54.0	-8.3	1.04 H	319	6.56	39.14
9	7311.00	57.1 PK	74.0	-16.9	1.04 H	219	10.47	46.63
10	7311.00	39.2 AV	54.0	-14.8	1.04 H	219	-7.43	46.63

ANTENNA POLARITY & TEST DISTANCE: VERTICAL AT 3 M

NO.	FREQ. (MHz)	EMISSION LEVEL (dBuV/m)	LIMIT (dBuV/m)	MARGIN (dB)	ANTENNA HEIGHT (m)	TABLE ANGLE (Degree)	RAW VALUE (dBuV)	CORRECTION FACTOR (dB/m)
1	*2437.00	102.7 PK			1.06 V	283	70.89	31.81
2	*2437.00	92.4 AV			1.06 V	283	60.59	31.81
3	4874.00	56.1 PK	74.0	-17.9	1.27 V	219	16.96	39.14
4	4874.00	35.2 AV	54.0	-18.8	1.27 V	219	-3.94	39.14
5	7311.00	57.2 PK	74.0	-16.8	1.21 V	63	10.57	46.63
6	7311.00	39.4 AV	54.0	-14.6	1.21 V	63	-7.23	46.63

- REMARKS:**
1. Emission level (dBuV/m) = Raw Value (dBuV) + Correction Factor (dB/m).
 2. Correction Factor (dB/m) = Antenna Factor (dB/m) + Cable Factor (dB).
 3. The other emission levels were very low against the limit.
 4. Margin value = Emission level – Limit value.
 5. “ * “: Fundamental frequency.



A D T

EUT TEST CONDITION		MEASUREMENT DETAIL	
CHANNEL	Channel 9	FREQUENCY RANGE	1 ~ 25GHz
INPUT POWER	120Vac, 60 Hz	DETECTOR FUNCTION	Peak (PK) Average (AV)
ENVIRONMENTAL CONDITIONS	22deg. C, 66%RH 1022 hPa	TESTED BY	Evan Huang

ANTENNA POLARITY & TEST DISTANCE: HORIZONTAL AT 3 M

NO.	FREQ. (MHz)	EMISSION LEVEL (dBuV/m)	LIMIT (dBuV/m)	MARGIN (dB)	ANTENNA HEIGHT (m)	TABLE ANGLE (Degree)	RAW VALUE (dBuV)	CORRECTION FACTOR (dB/m)
1	*2452.00	103.5 PK			1.08 H	344	71.64	31.86
2	*2452.00	93.7 AV			1.08 H	344	61.84	31.86
3	2483.50	68.1 PK	74.0	-5.9	1.09 H	345	36.13	31.97
4	2483.50	53.2 AV	54.0	-0.8	1.09 H	345	21.23	31.97
5	4904.00	60.4 PK	74.0	-13.6	1.02 H	320	21.16	39.24
6	4904.00	45.1 AV	54.0	-8.9	1.02 H	320	5.86	39.24
7	7356.00	57.2 PK	74.0	-16.8	1.03 H	242	10.59	46.61
8	7356.00	39.4 AV	54.0	-14.6	1.03 H	242	-7.21	46.61

ANTENNA POLARITY & TEST DISTANCE: VERTICAL AT 3 M

NO.	FREQ. (MHz)	EMISSION LEVEL (dBuV/m)	LIMIT (dBuV/m)	MARGIN (dB)	ANTENNA HEIGHT (m)	TABLE ANGLE (Degree)	RAW VALUE (dBuV)	CORRECTION FACTOR (dB/m)
1	*2452.00	95.1 PK			1.00 V	263	63.24	31.86
2	*2452.00	85.9 AV			1.00 V	263	54.04	31.86
3	2483.50	61.8 PK	74.0	-12.2	1.00 V	263	29.83	31.97
4	2483.50	50.0 AV	54.0	-4.0	1.00 V	263	18.03	31.97
5	4904.00	56.2 PK	74.0	-17.8	1.26 V	214	16.96	39.24
6	4904.00	35.3 AV	54.0	-18.7	1.26 V	214	-3.94	39.24
7	7356.00	57.3 PK	74.0	-16.7	1.24 V	59	10.69	46.61
8	7356.00	39.1 AV	54.0	-14.9	1.24 V	59	-7.51	46.61

- REMARKS:**
1. Emission level (dBuV/m) = Raw Value (dBuV) + Correction Factor (dB/m).
 2. Correction Factor (dB/m) = Antenna Factor (dB/m) + Cable Factor (dB).
 3. The other emission levels were very low against the limit.
 4. Margin value = Emission level – Limit value.
 5. “ * “: Fundamental frequency.



A D T

RESTRICTED BANDEDGE (802.11n (40MHz) MODE,CH3, HORIZONTAL)

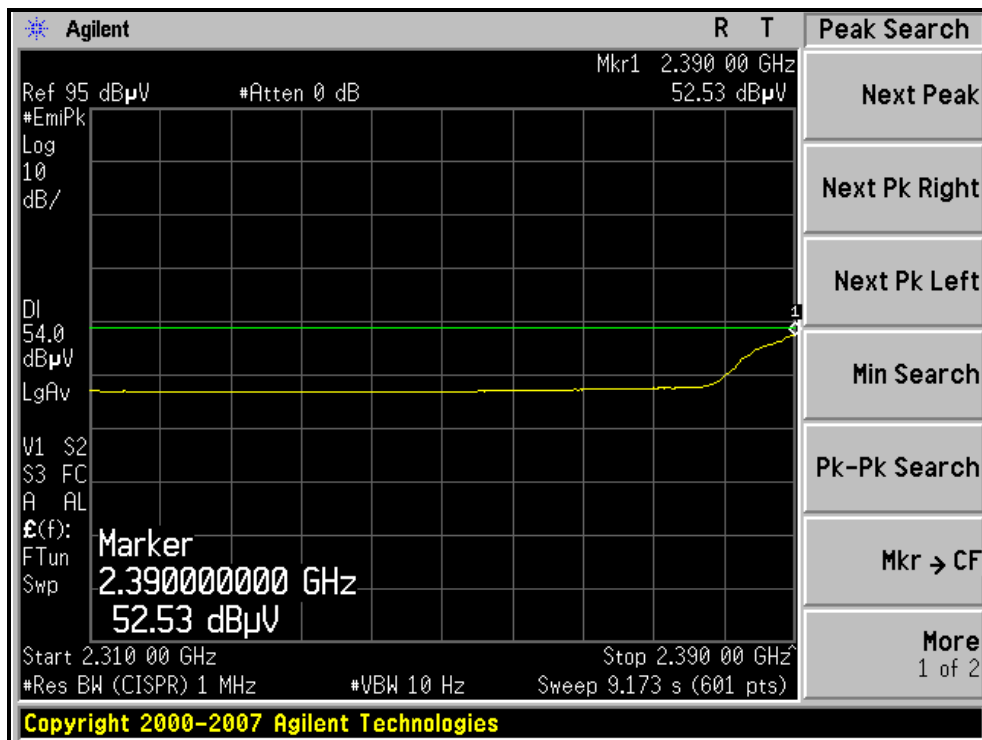
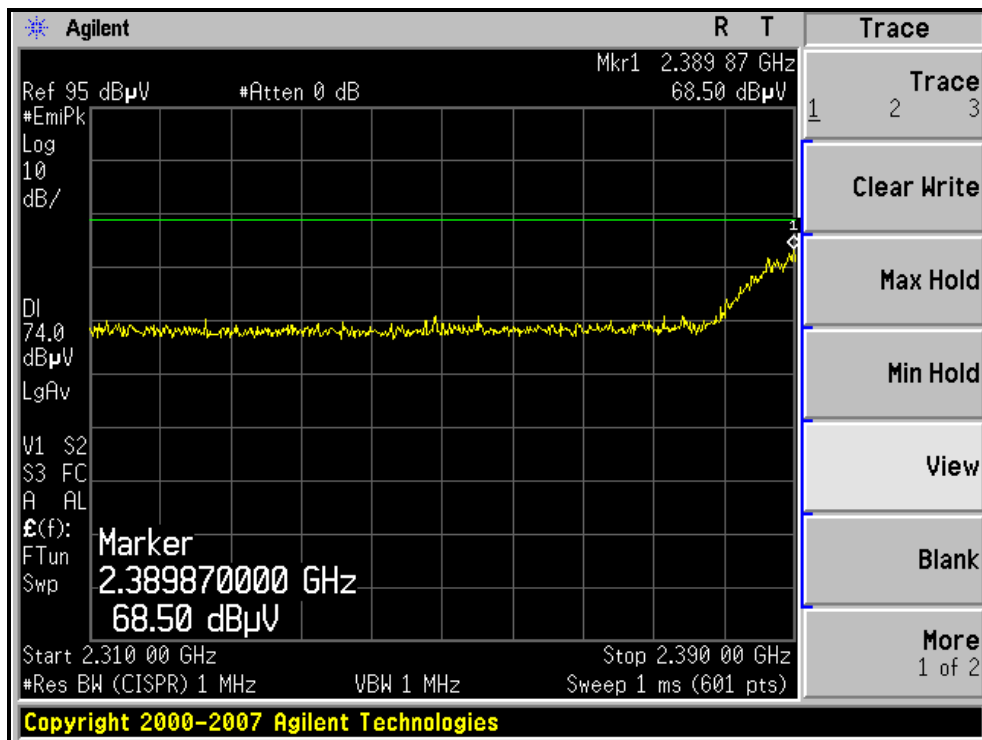



A D T

RESTRICTED BANDEDGE (802.11n (40MHz) MODE,CH3, VERTICAL)

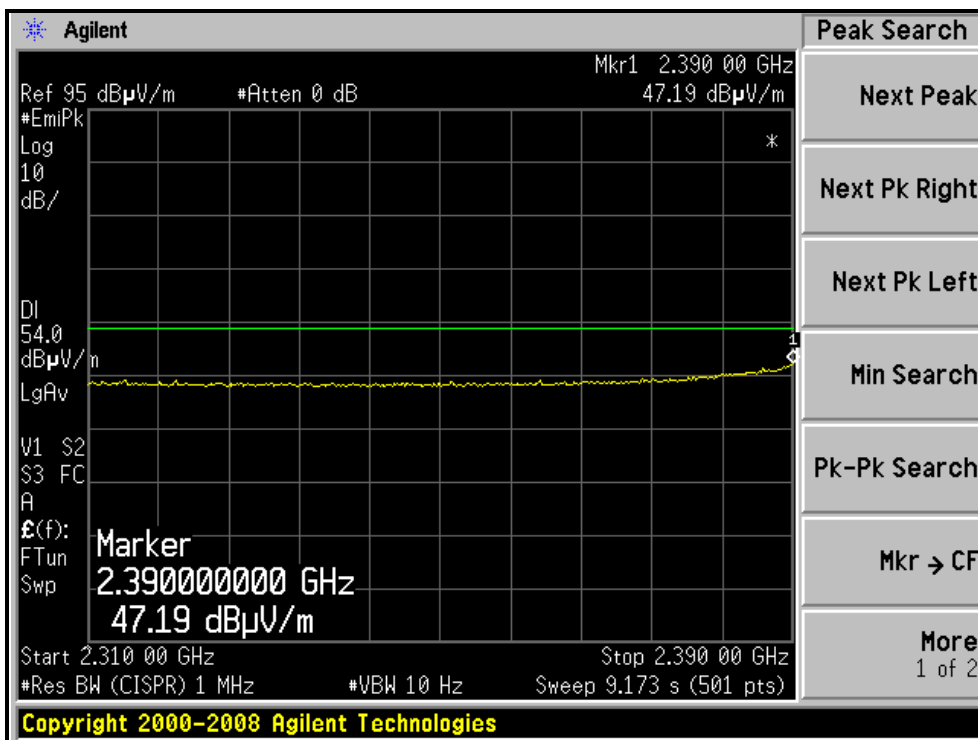
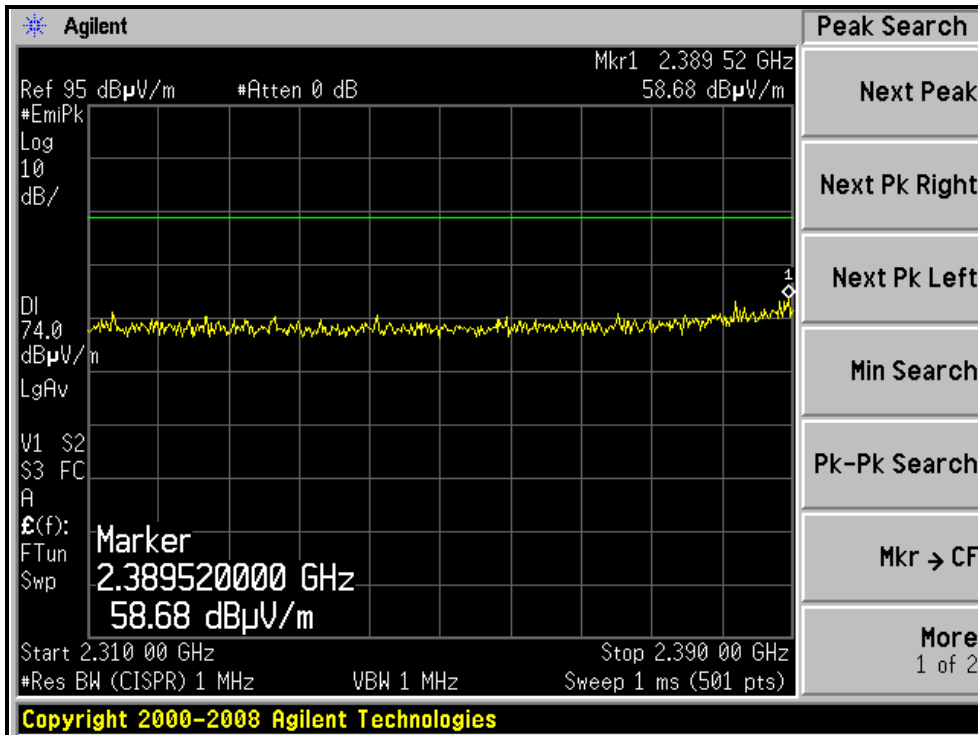



A D T

RESTRICTED BANDEDGE (802.11n (40MHz) MODE,CH9, HORIZONTAL)

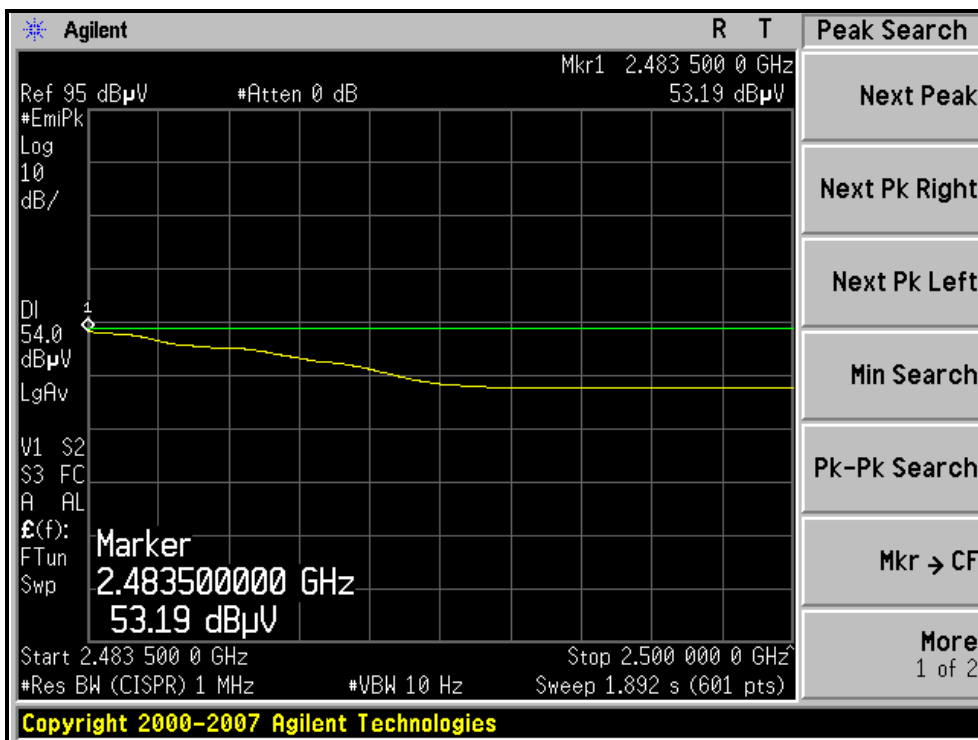
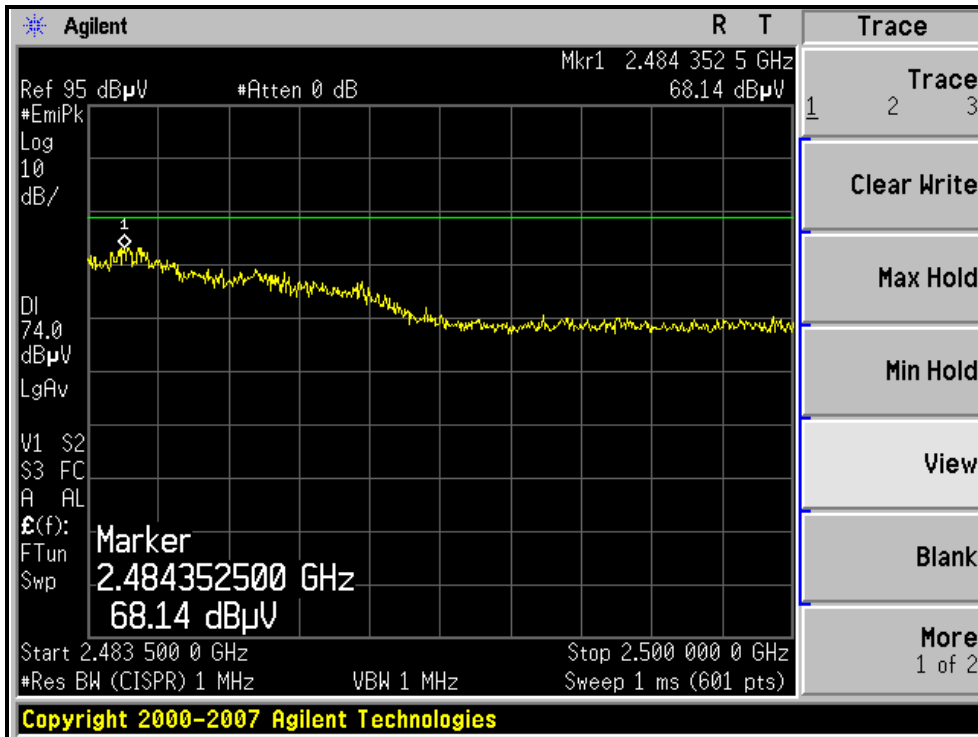



A D T

RESTRICTED BANDEDGE (802.11n (40MHz) MODE,CH9, VERTICAL)

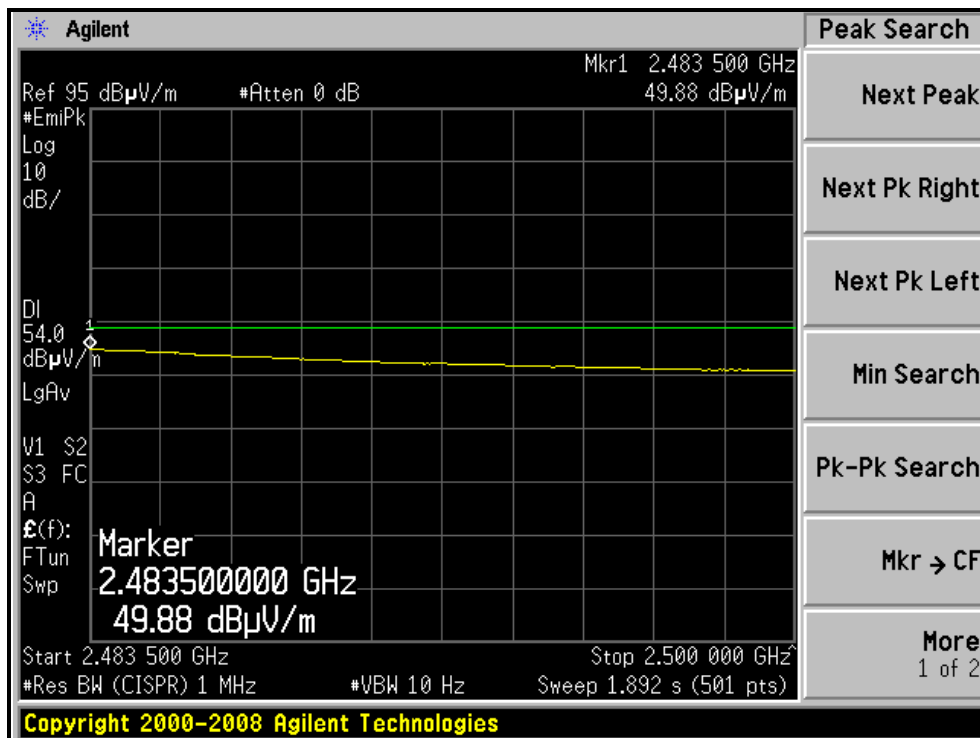
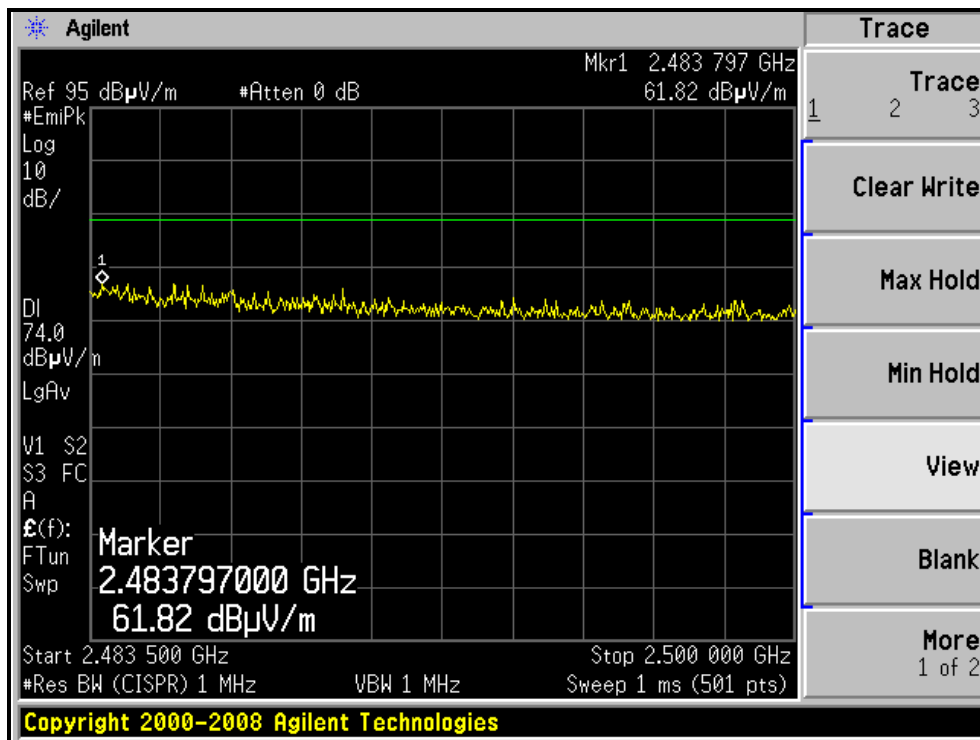

4.3 6dB BANDWIDTH MEASUREMENT

4.3.1 LIMITS OF 6dB BANDWIDTH MEASUREMENT

The minimum of 6dB Bandwidth Measurement is 0.5 MHz.

4.3.2 TEST INSTRUMENTS

DESCRIPTION & MANUFACTURER	MODEL NO.	SERIAL NO.	CALIBRATED DATE	CALIBRATED UNTIL
R&S SPECTRUM ANALYZER	FSP40	100037	Sep. 08, 2010	Sep. 07, 2011

NOTE:

1. The calibration interval of the above test instruments is 12 months and the calibrations are traceable to NML/ROC and NIST/USA.

4.3.3 TEST PROCEDURE

The transmitter output was connected to the spectrum analyzer through an attenuator. The bandwidth of the fundamental frequency was measured by spectrum analyzer with 100kHz RBW and 300kHz VBW. The 6dB bandwidth is defined as the total spectrum the power of which is higher than peak power minus 6dB.

4.3.4 DEVIATION FROM TEST STANDARD

No deviation

4.3.5 TEST SETUP



4.3.6 EUT OPERATING CONDITIONS

The software provided by client to enable the EUT under transmission condition continuously at lowest, middle and highest channel frequencies individually.

4.3.7 TEST RESULTS

802.11b DSSS MODULATION:

CHANNEL	CHANNEL FREQUENCY (MHz)	6dB BANDWIDTH (MHz)	MINIMUM LIMIT (MHz)	PASS / FAIL
1	2412	11.27	0.5	PASS
6	2437	11.26	0.5	PASS
11	2462	11.23	0.5	PASS

CH1

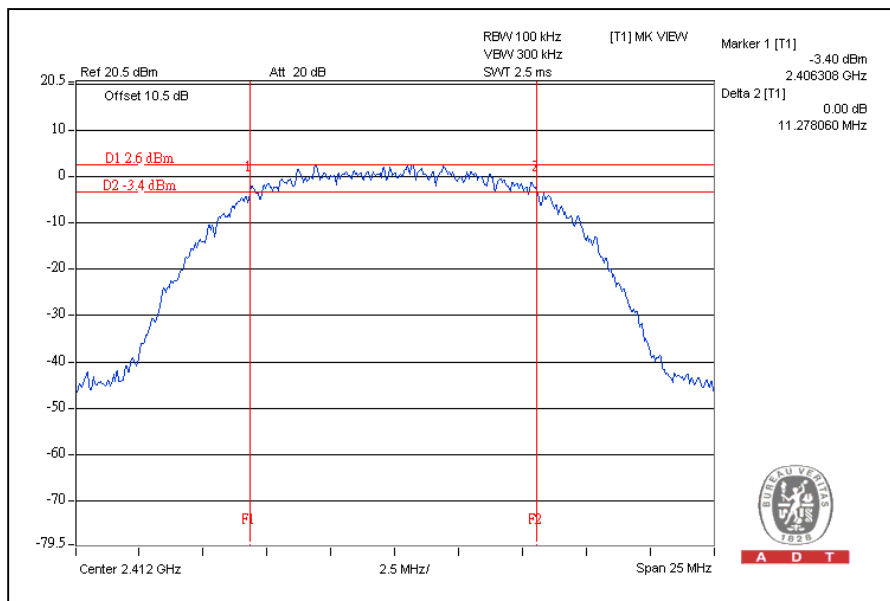



A D T

802.11g OFDM MODULATION:

CHANNEL	CHANNEL FREQUENCY (MHz)	6dB BANDWIDTH (MHz)	MINIMUM LIMIT (MHz)	PASS / FAIL
1	2412	16.60	0.5	PASS
6	2437	16.58	0.5	PASS
11	2462	16.56	0.5	PASS

CH1

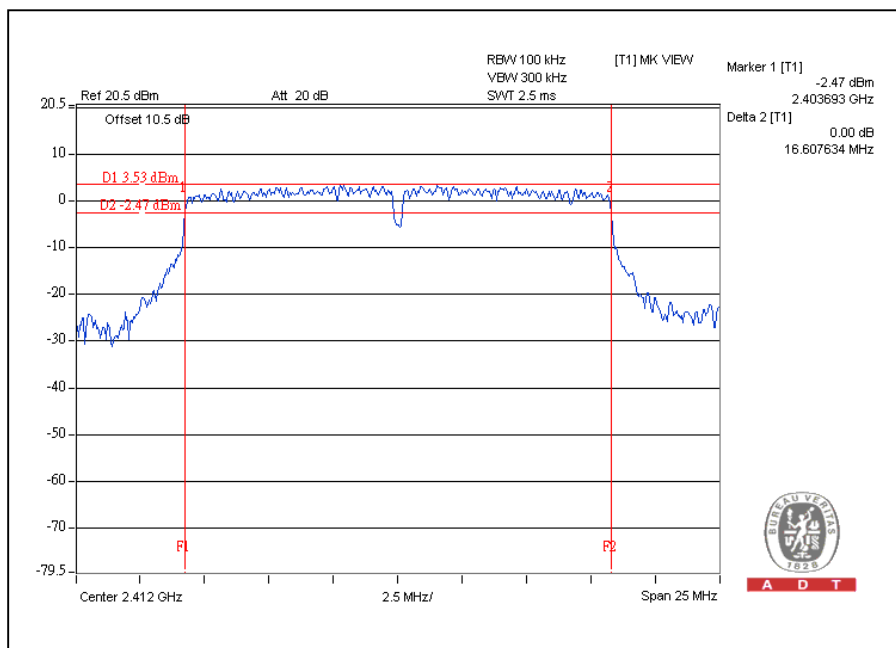



A D T

802.11n (20MHz) OFDM MODULATION:

CHANNEL	CHANNEL FREQUENCY (MHz)	6dB BANDWIDTH (MHz)	MINIMUM LIMIT (MHz)	PASS / FAIL
1	2412	17.73	0.5	PASS
6	2437	17.71	0.5	PASS
11	2462	17.68	0.5	PASS

CH1

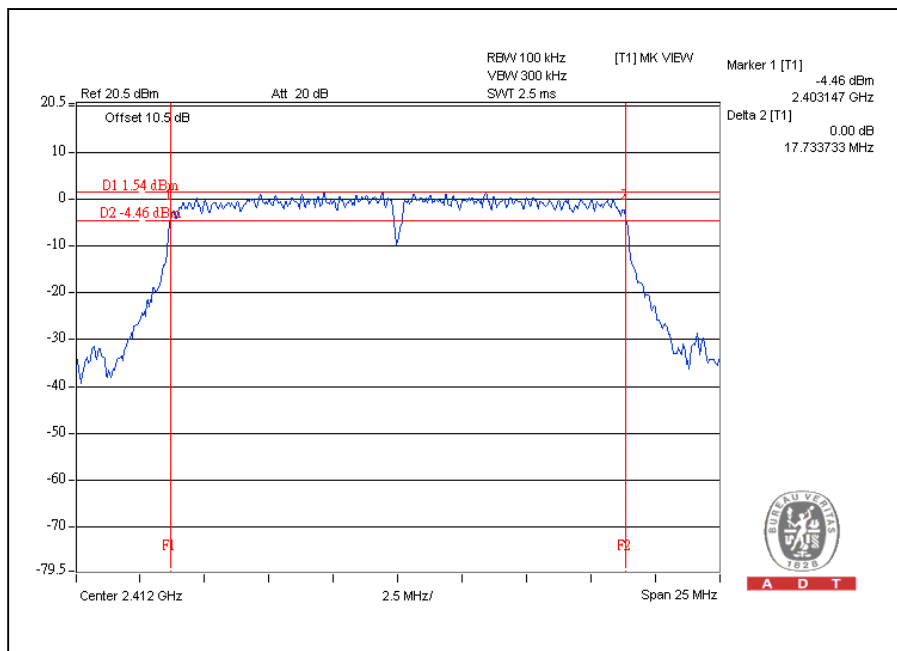

802.11n (40MHz) OFDM MODULATION:

CHANNEL	CHANNEL FREQUENCY (MHz)	6dB BANDWIDTH (MHz)	MINIMUM LIMIT (MHz)	PASS / FAIL
3	2422	36.48	0.5	PASS
6	2437	36.53	0.5	PASS
9	2452	36.53	0.5	PASS

CH6

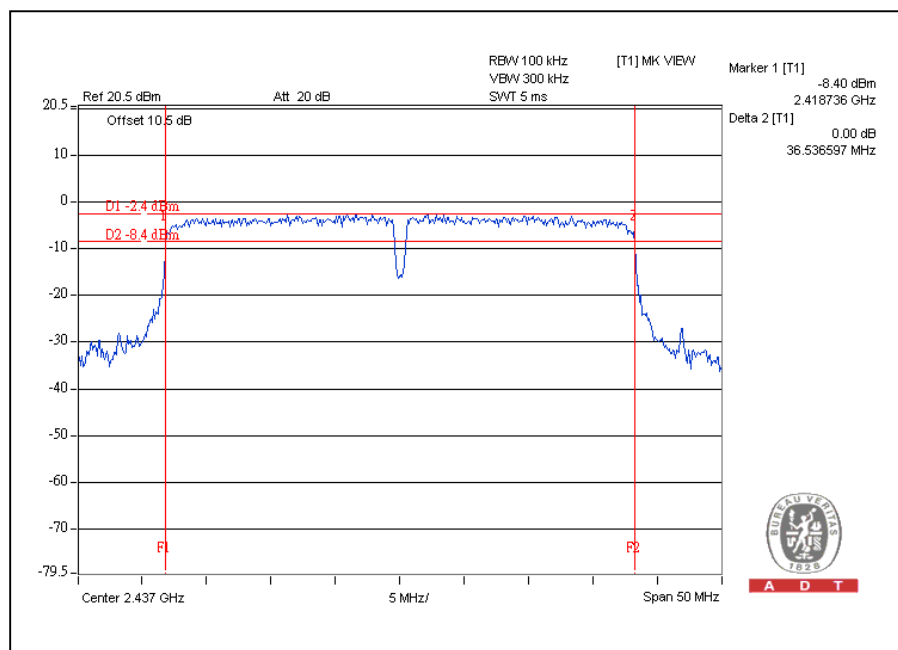

4.4 MAXIMUM PEAK OUTPUT POWER

4.4.1 LIMITS OF MAXIMUM PEAK OUTPUT POWER MEASUREMENT

The Maximum Peak Output Power Measurement is 30dBm.

4.4.2 INSTRUMENTS

DESCRIPTION & MANUFACTURER	MODEL NO.	SERIAL NO.	CALIBRATED DATE	CALIBRATED UNTIL
Anritsu Power Meter	ML2495A	0824006	May 04, 2010	May 03, 2011
Pulse Power Sensor	MA2411B	0738172	May 04, 2010	May 03, 2011

NOTE:

The calibration interval of the above test instruments is 12 months and the calibrations are traceable to NML/ROC and NIST/USA.

4.4.3 TEST PROCEDURES

1. The transmitter output was connected to the power meter through an attenuator; the bandwidth of the fundamental frequency was measured with the power meter.
2. Record the power level.

4.4.4 DEVIATION FROM TEST STANDARD

No deviation

4.4.5 TEST SETUP

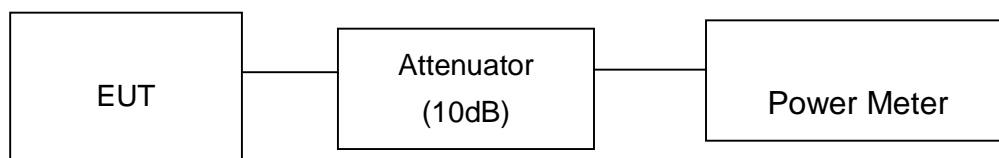

4.4.6 EUT OPERATING CONDITIONS

Same as Item 4.3.6

4.4.7 TEST RESULTS

802.11b DSSS MODULATION:

CHANNEL	CHANNEL FREQUENCY (MHz)	PEAK POWER OUTPUT (mW)	PEAK POWER OUTPUT (dBm)	PEAK POWER LIMIT (dBm)	PASS / FAIL
1	2412	49.0	16.9	30	PASS
6	2437	66.1	18.2	30	PASS
11	2462	117.5	20.7	30	PASS

802.11g OFDM MODULATION:

CHANNEL	CHANNEL FREQUENCY (MHz)	PEAK POWER OUTPUT (mW)	PEAK POWER OUTPUT (dBm)	PEAK POWER LIMIT (dBm)	PASS / FAIL
1	2412	281.8	24.5	30	PASS
6	2437	288.4	24.6	30	PASS
11	2462	182.0	22.6	30	PASS

802.11n (20MHz) OFDM MODULATION:

CHANNEL	CHANNEL FREQUENCY (MHz)	PEAK POWER OUTPUT (mW)	PEAK POWER OUTPUT (dBm)	PEAK POWER LIMIT (dBm)	PASS / FAIL
1	2412	275.4	24.4	30	PASS
6	2437	302.0	24.8	30	PASS
11	2462	141.3	21.5	30	PASS

802.11n (40MHz) OFDM MODULATION:

CHANNEL	CHANNEL FREQUENCY (MHz)	PEAK POWER OUTPUT (mW)	PEAK POWER OUTPUT (dBm)	PEAK POWER LIMIT (dBm)	PASS / FAIL
3	2422	64.6	18.1	30	PASS
6	2437	239.9	23.8	30	PASS
9	2452	56.2	17.5	30	PASS

4.5 POWER SPECTRAL DENSITY MEASUREMENT

4.5.1 LIMITS OF POWER SPECTRAL DENSITY MEASUREMENT

The Maximum of Power Spectral Density Measurement is 8dBm.

4.5.2 TEST INSTRUMENTS

DESCRIPTION & MANUFACTURER	MODEL NO.	SERIAL NO.	CALIBRATED DATE	CALIBRATED UNTIL
R&S SPECTRUM ANALYZER	FSP40	100037	Sep. 08, 2010	Sep. 07, 2011

NOTE:

1. The calibration interval of the above test instruments is 12 months and the calibrations are traceable to NML/ROC and NIST/USA.

4.5.3 TEST PROCEDURE

The transmitter output was connected to the spectrum analyzer through an attenuator, the bandwidth of the fundamental frequency was measured with the spectrum analyzer using 3kHz RBW and 30kHz VBW, set sweep time = span/3kHz. The power spectral density was measured and recorded.

The sweep time is allowed to be longer than span/3kHz for a full response of the mixer in the spectrum analyzer.

4.5.4 DEVIATION FROM TEST STANDARD

No deviation

4.5.5 TEST SETUP

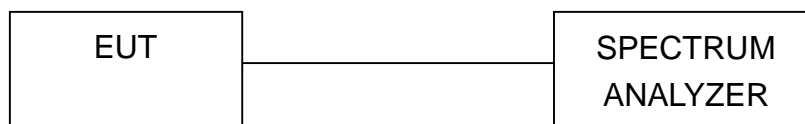

4.5.6 EUT OPERATING CONDITION

Same as Item 4.3.6



A D T

4.5.7 TEST RESULTS

802.11b DSSS MODULATION:

CHANNEL	CHANNEL FREQUENCY (MHz)	RF POWER LEVEL IN 3kHz BW (dBm)	MAXIMUM LIMIT (dBm)	PASS / FAIL
1	2412	-10.6	8	PASS
6	2437	-9.3	8	PASS
11	2462	-6.6	8	PASS

CH11

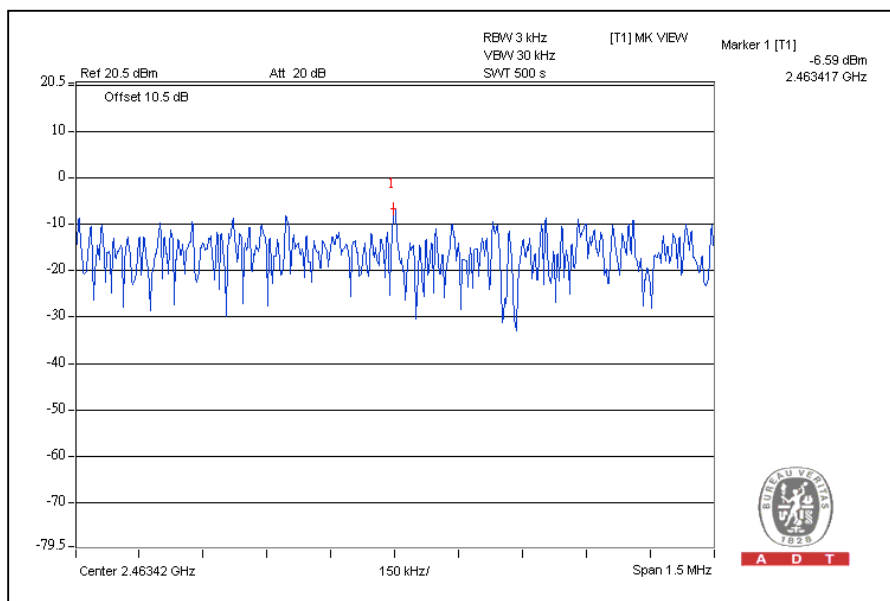



A D T

802.11g OFDM MODULATION:

CHANNEL	CHANNEL FREQUENCY (MHz)	RF POWER LEVEL IN 3kHz BW (dBm)	MAXIMUM LIMIT (dBm)	PASS / FAIL
1	2412	-10.5	8	PASS
6	2437	-9.8	8	PASS
11	2462	-14.7	8	PASS

CH6

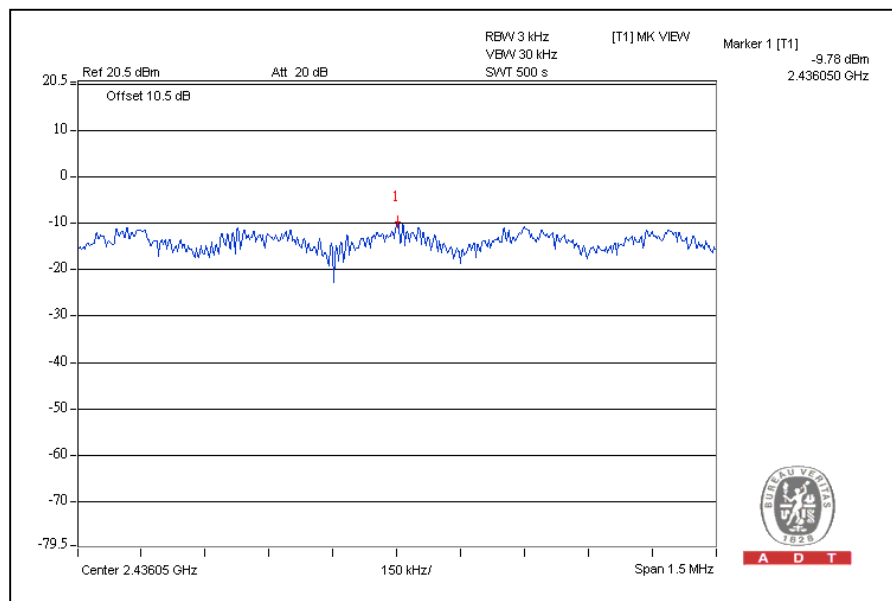



A D T

802.11n (20MHz) OFDM MODULATION:

CHANNEL	CHANNEL FREQUENCY (MHz)	RF POWER LEVEL IN 3kHz BW (dBm)	MAXIMUM LIMIT (dBm)	PASS / FAIL
1	2412	-12.3	8	PASS
6	2437	-10.0	8	PASS
11	2462	-14.8	8	PASS

CH6

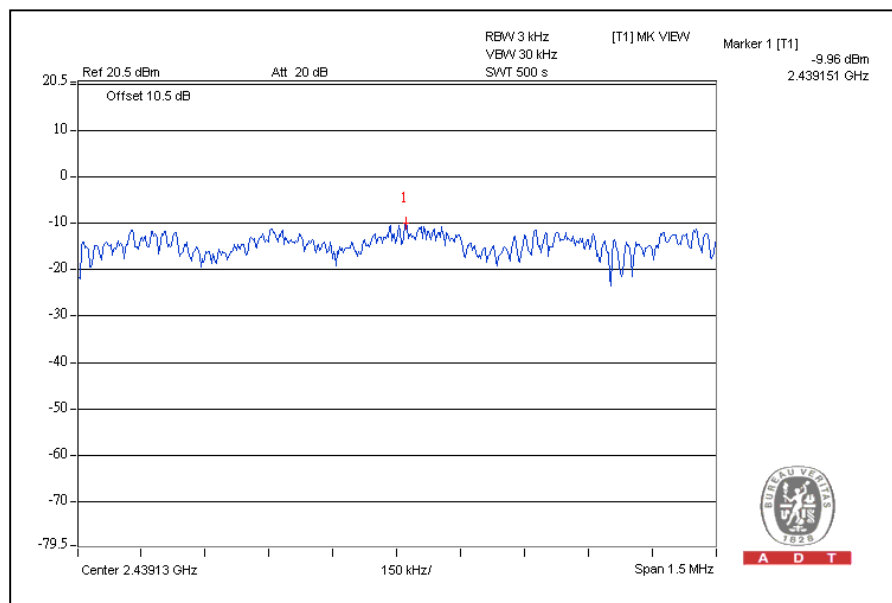



A D T

802.11n (40MHz) OFDM MODULATION:

CHANNEL	CHANNEL FREQUENCY (MHz)	RF POWER LEVEL IN 3kHz BW (dBm)	MAXIMUM LIMIT (dBm)	PASS / FAIL
3	2422	-21.2	8	PASS
6	2437	-15.0	8	PASS
9	2452	-22.0	8	PASS

CH6

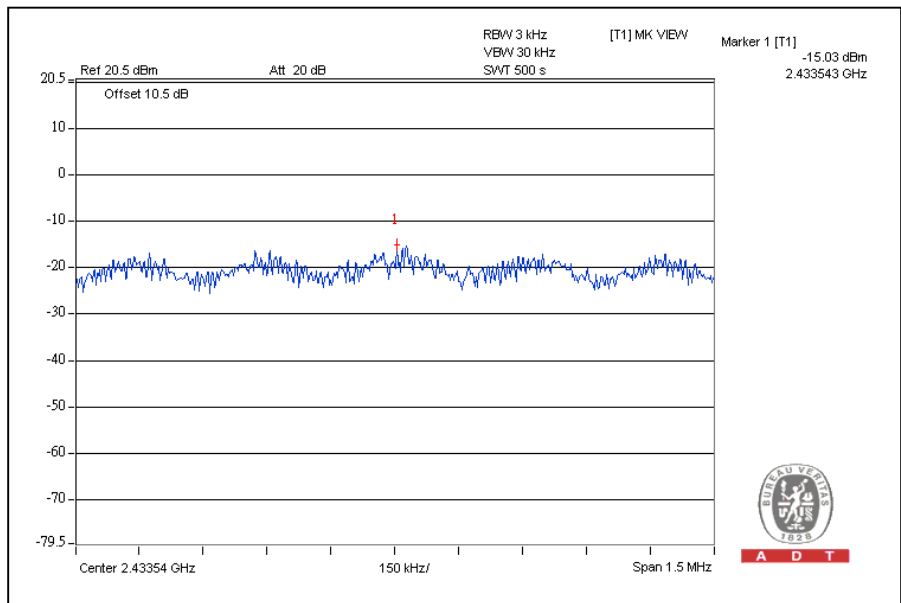

4.6 CONDUCTED OUT-BAND EMISSION MEASUREMENT

4.6.1 LIMITS OF CONDUCTED OUT-BAND EMISSION MEASUREMENT

Below -20dB of the highest emission level of operating band (in 100kHz Resolution Bandwidth).

4.6.2 TEST INSTRUMENTS

DESCRIPTION & MANUFACTURER	MODEL NO.	SERIAL NO.	CALIBRATED DATE	CALIBRATED UNTIL
R&S SPECTRUM ANALYZER	FSP40	100037	Sep. 08, 2010	Sep. 07, 2011

NOTE:

1. The calibration interval of the above test instruments is 12 months and the calibrations are traceable to NML/ROC and NIST/USA.

4.6.3 TEST PROCEDURE

The transmitter output was connected to the spectrum analyzer via a low loss cable. Set RBW of spectrum analyzer to 100kHz and VBW of spectrum analyzer to 300kHz with suitable frequency span including 100 MHz or 200 MHz bandwidth from band edge. The band edges was measured and recorded.

The spectrum plots (RBW = 100kHz, VBW = 300kHz) are attached on the following pages.

4.6.4 DEVIATION FROM TEST STANDARD

No deviation

4.6.5 EUT OPERATING CONDITION

Same as Item 4.3.6

4.6.6 TEST RESULTS

The spectrum plots are attached on the following images. D1 line indicates the highest level, and D2 line indicates the 20dB offset below D1. It shows compliance with the requirement in part 15.247(d).

802.11b DSSS MODULATION:

CH1

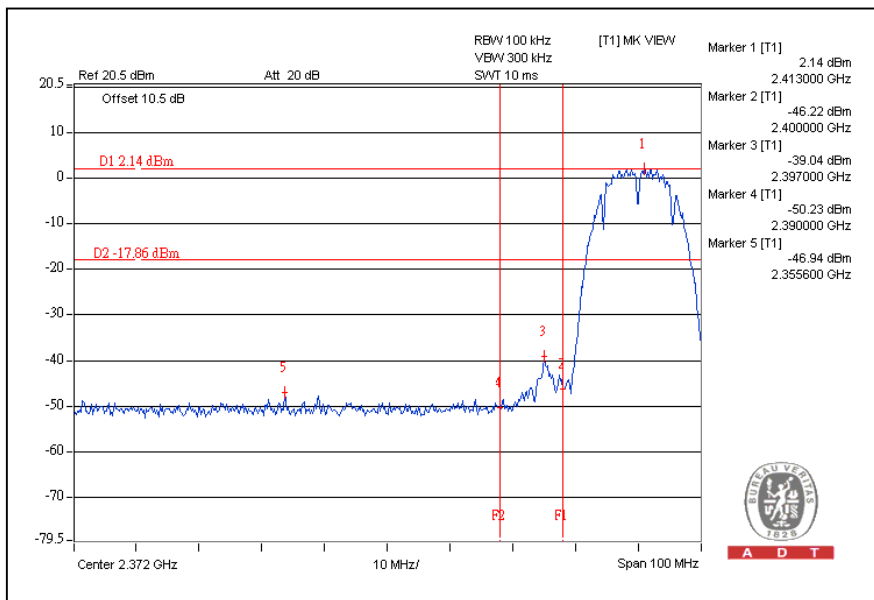

CH11

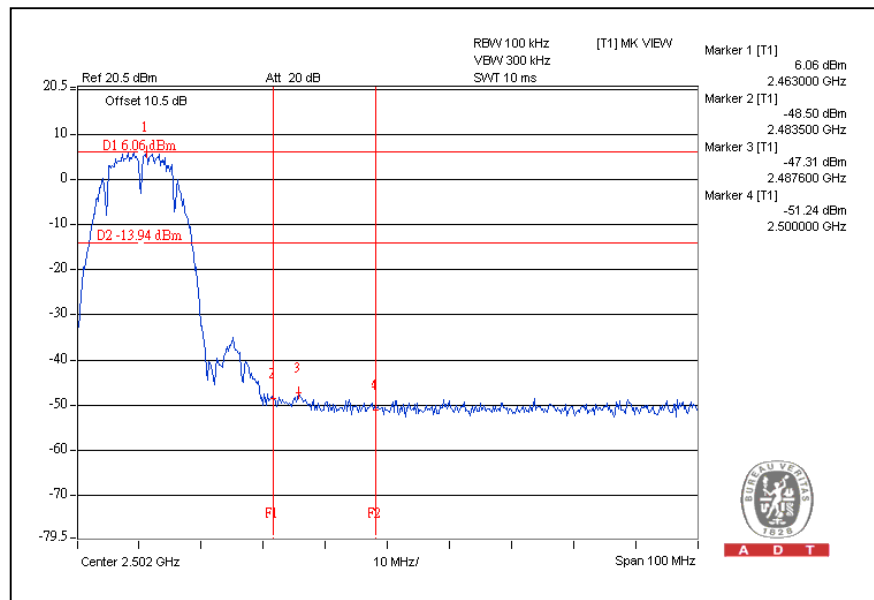



A D T

CH1

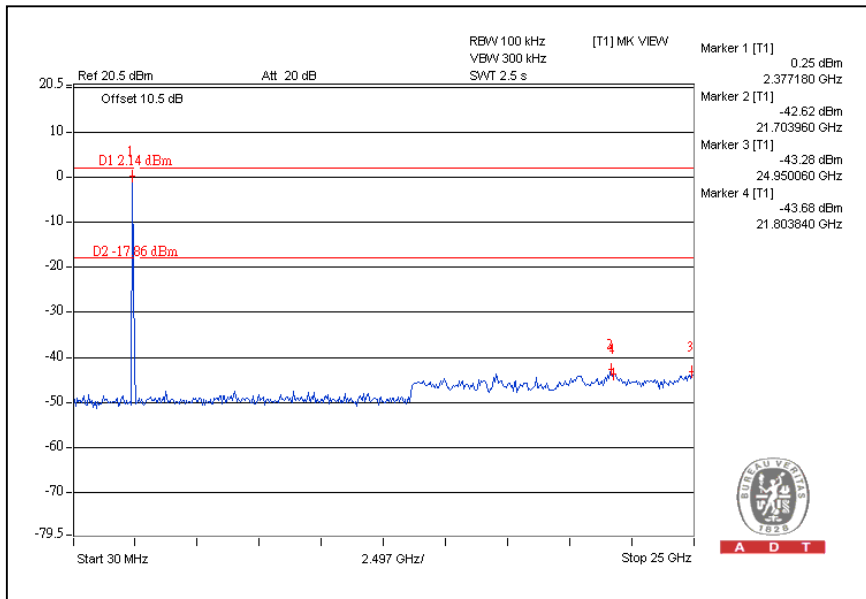

CH11

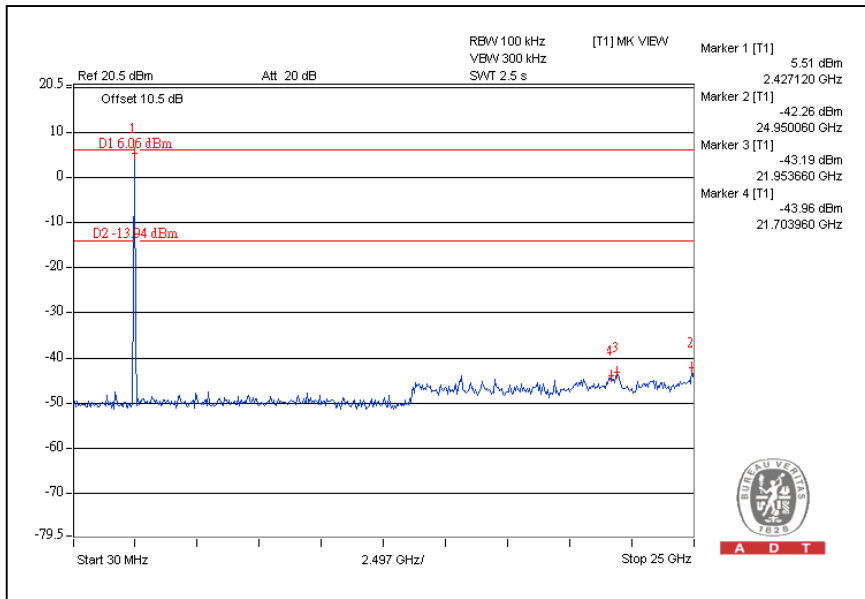

802.11g OFDM MODULATION:

CH1

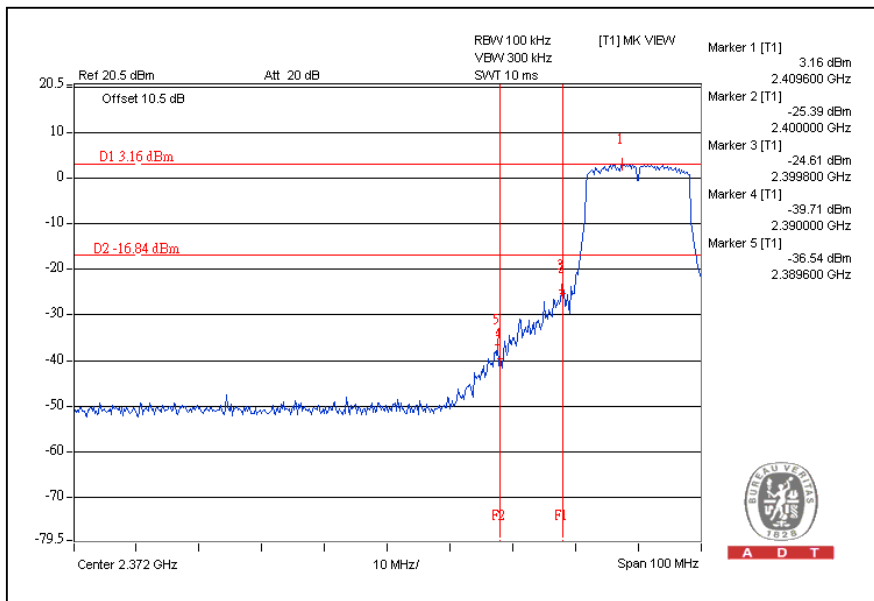

CH11

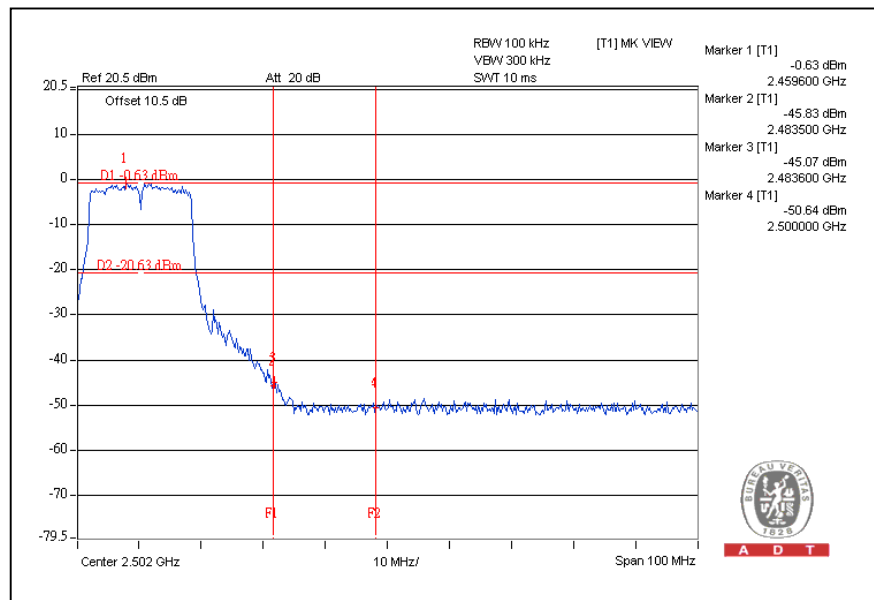



A D T

CH1

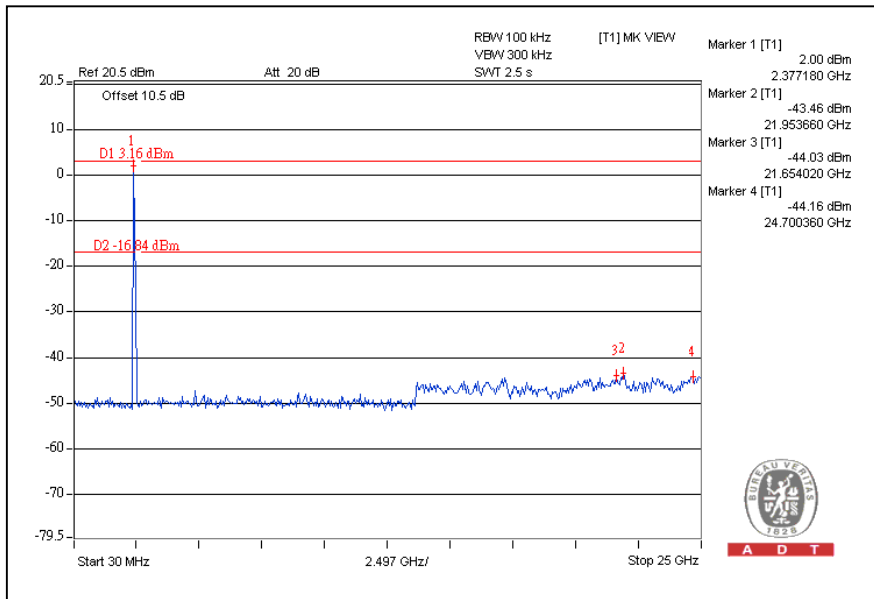

CH11

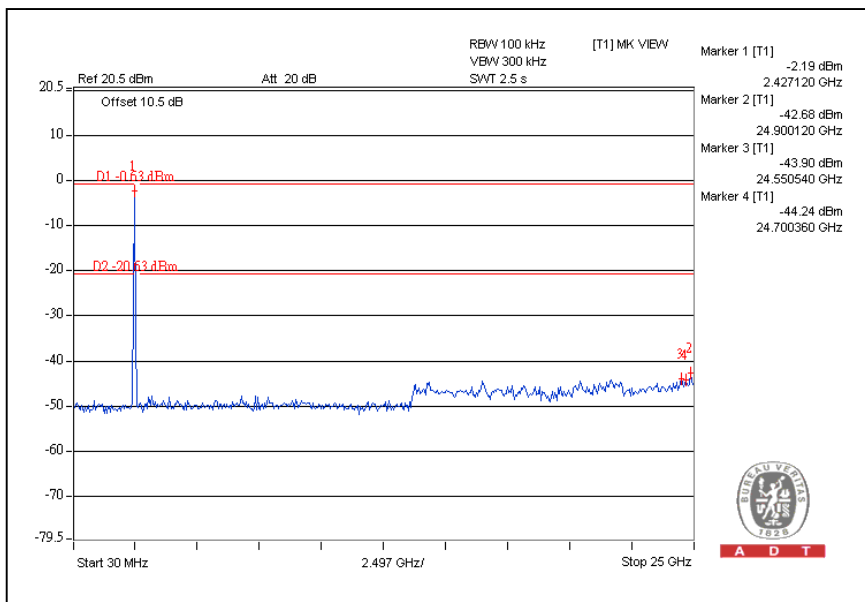

802.11n (20MHz) OFDM MODULATION:

CH1

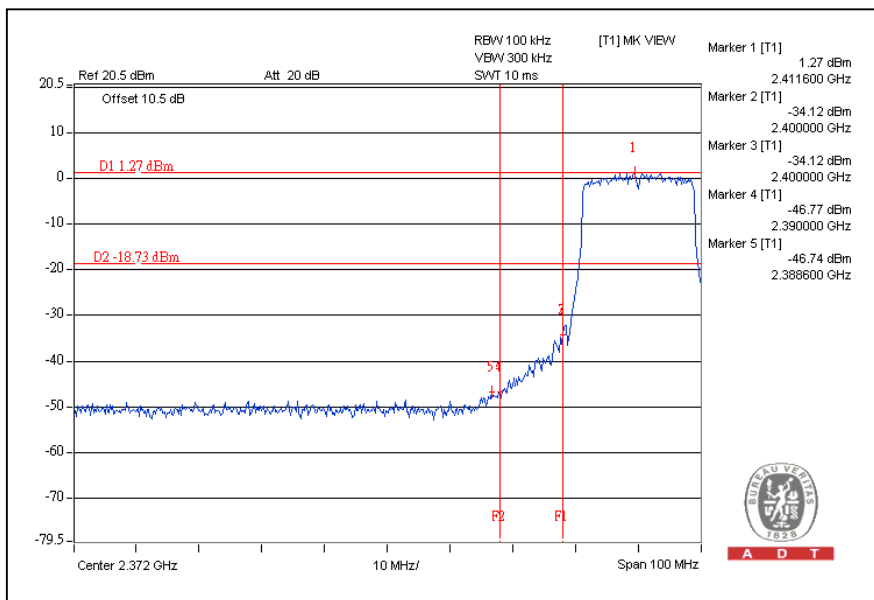

CH11

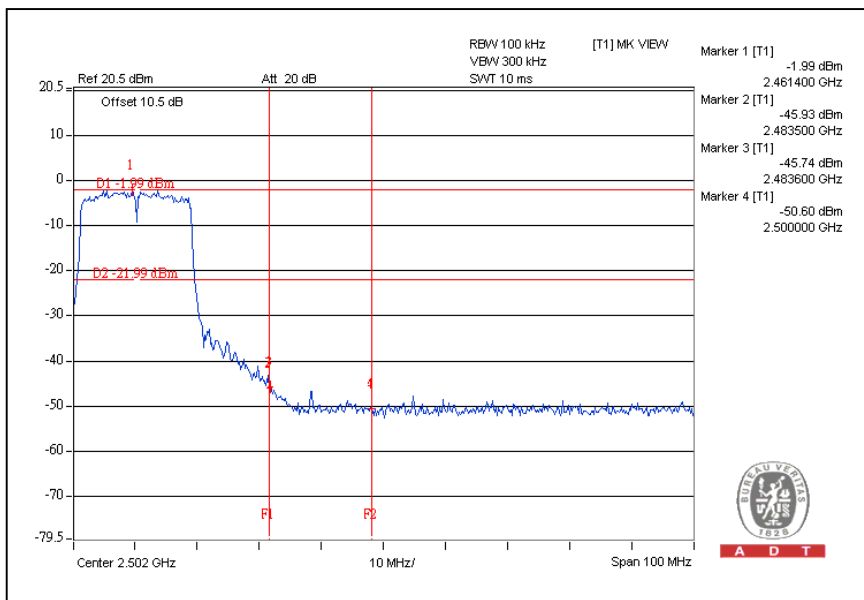



A D T

CH1

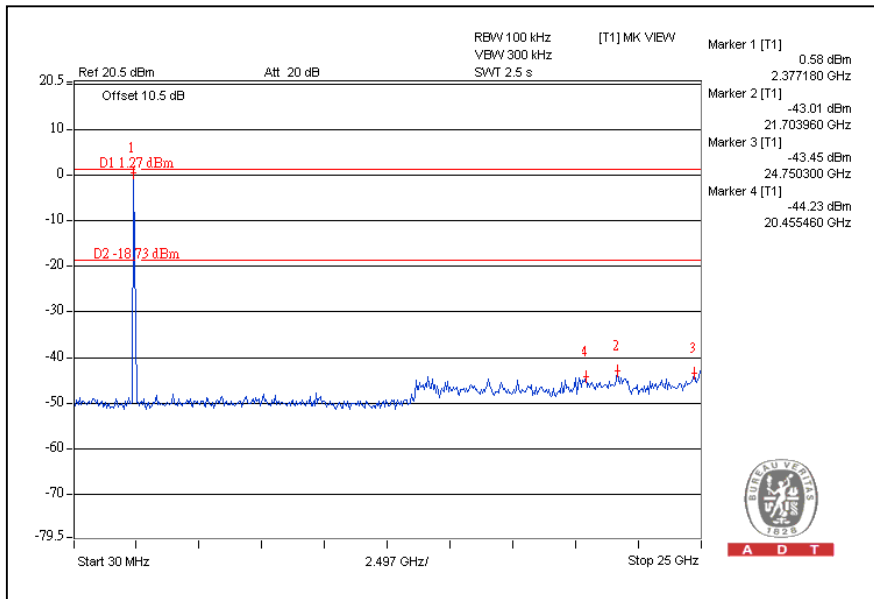

CH11

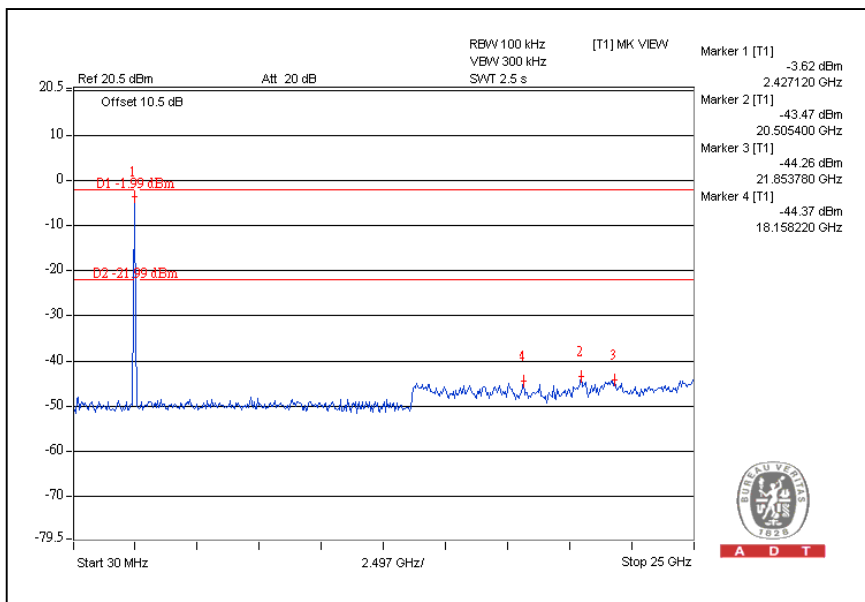

802.11n (40MHz) OFDM MODULATION:

CH3

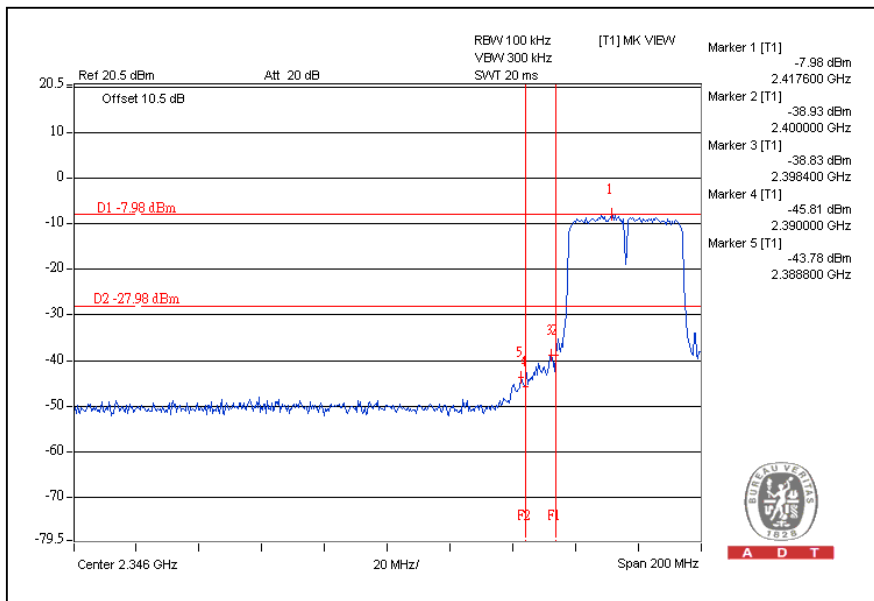

CH9

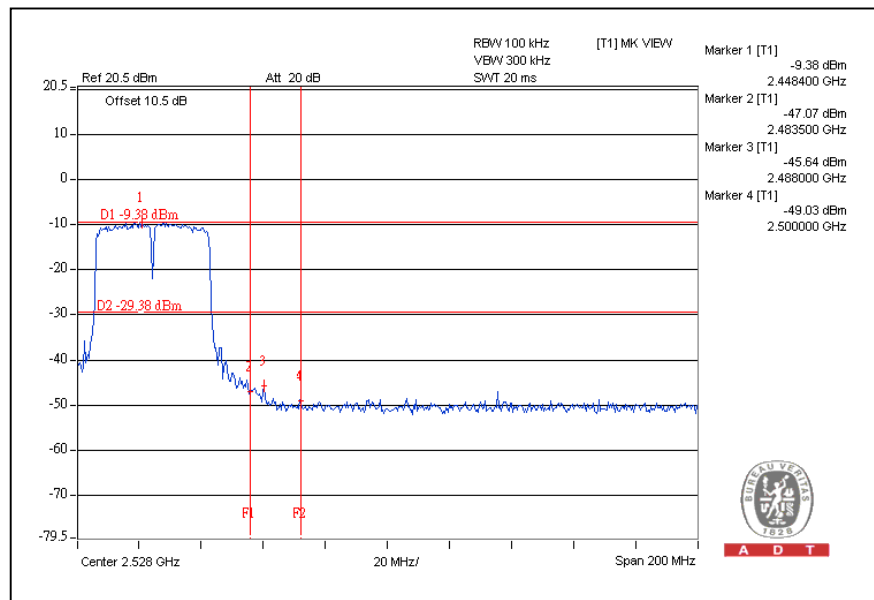



A D T

CH3

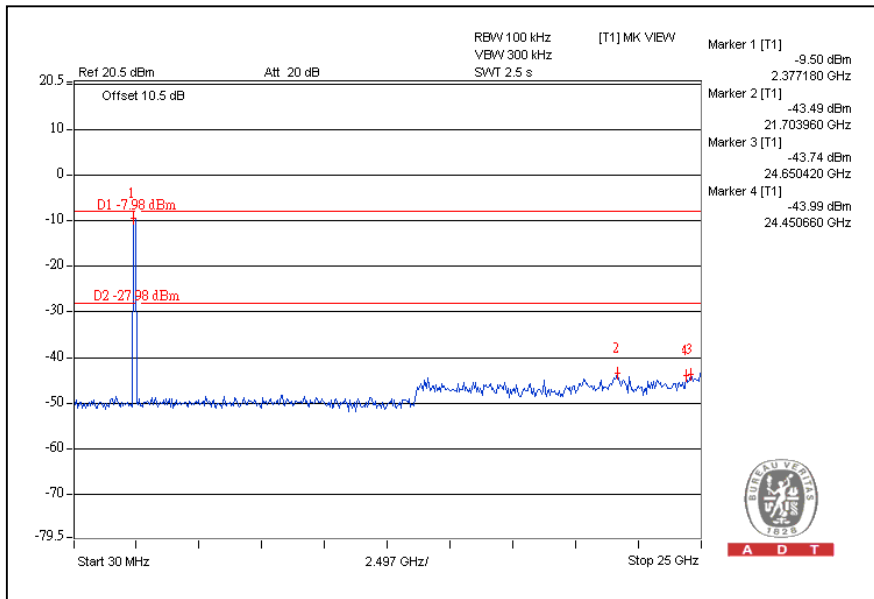

CH9

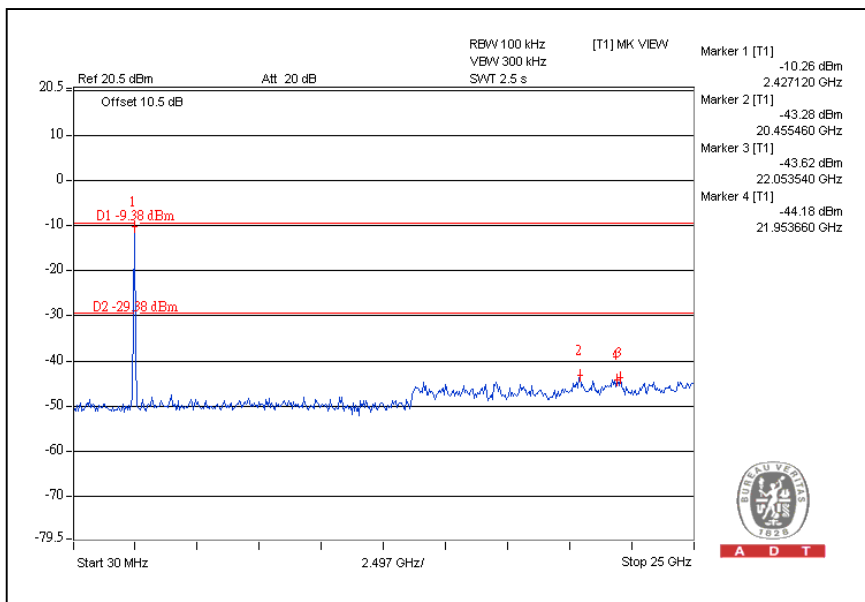



5. INFORMATION ON THE TESTING LABORATORIES

We, Bureau Veritas Consumer Products Services (H.K.) Ltd., Taoyuan Branch, were founded in 1988 to provide our best service in EMC, Radio, Telecom and Safety consultation. Our laboratories are accredited and approved according to ISO/IEC 17025:

Copies of accreditation certificates of our laboratories obtained from approval agencies can be downloaded from our web site: www.adt.com.tw/index.5.phtml.

If you have any comments, please feel free to contact us at the following:

Linko EMC/RF Lab:

Tel: 886-2-26052180

Fax: 886-2-26052943

Hsin Chu EMC/RF Lab:

Tel: 886-3-5935343

Fax: 886-3-5935342

Hwa Ya EMC/RF/Safety/Telecom Lab:

Tel: 886-3-3183232

Fax: 886-3-3185050

Email: service@adt.com.tw

Web Site: www.adt.com.tw

The address and road map of all our labs can be found in our web site also.



A D T

6.APPENDIX A - MODIFICATIONS RECORDERS FOR ENGINEERING CHANGES TO THE EUT BY THE LAB

No any modifications are made to the EUT by the lab during the test.

--- END ---