

FCC Test Report

Report No.: RF160706E06-1

FCC ID: ZMYDSL2401HNAT1CC

Test Model: DSL-2401HNA-T1CC

Received Date: July 06, 2016

Test Date: July 20 to 29, 2016

Issued Date: Sep. 20, 2016

Applicant: MitraStar Technology Corporation

Address: No. 6, Innovation Rd II, Hsinchu Science Park, Hsinchu 30076, Taiwan

Issued By: Bureau Veritas Consumer Products Services (H.K.) Ltd., Taoyuan Branch
Hsin Chu Laboratory

Lab Address: E-2, No.1, Li Hsin 1st Road, Hsinchu Science Park, Hsinchu City 300,
Taiwan R.O.C.

Test Location (1): E-2, No.1, Li Hsin 1st Road, Hsinchu Science Park, Hsinchu City 300,
Taiwan R.O.C.

Test Location (2): No. 49, Ln. 206, Wende Rd., Shangshan Tsuen, Chiung Lin Hsiang, Hsin
Chu Hsien 307, Taiwan R.O.C.



This report is for your exclusive use. Any copying or replication of this report to or for any other person or entity, or use of our name or trademark, is permitted only with our prior written permission. This report sets forth our findings solely with respect to the test samples identified herein. The results set forth in this report are not indicative or representative of the quality or characteristics of the lot from which a test sample was taken or any similar or identical product unless specifically and expressly noted. Our report includes all of the tests requested by you and the results thereof based upon the information that you provided to us. You have 60 days from date of issuance of this report to notify us of any material error or omission caused by our negligence, provided, however, that such notice shall be in writing and shall specifically address the issue you wish to raise. A failure to raise such issue within the prescribed time shall constitute your unqualified acceptance of the completeness of this report, the tests conducted and the correctness of the report contents. Unless specific mention, the uncertainty of measurement has been explicitly taken into account to declare the compliance or non-compliance to the specification. The report must not be used by the client to claim product certification, approval, or endorsement by TAF or any government agencies.

Table of Contents

Release Control Record	4
1 Certificate of Conformity	5
2 Summary of Test Results	6
2.1 Measurement Uncertainty	6
2.2 Modification Record	6
3 General Information	7
3.1 General Description of EUT	7
3.2 Description of Test Modes	10
3.2.1 Test Mode Applicability and Tested Channel Detail	11
3.3 Duty Cycle of Test Signal	13
3.4 Description of Support Units	14
3.4.1 Configuration of System under Test	15
3.5 General Description of Applied Standard	16
4 Test Types and Results	17
4.1 Radiated Emission and Bandedge Measurement	17
4.1.1 Limits of Radiated Emission and Bandedge Measurement	17
4.1.2 Test Instruments	18
4.1.3 Test Procedure	19
4.1.4 Deviation from Test Standard	19
4.1.5 Test Setup	20
4.1.6 EUT Operating Condition	20
4.1.7 Test Results	21
4.2 Conducted Emission Measurement	40
4.2.1 Limits of Conducted Emission Measurement	40
4.2.2 Test Instruments	40
4.2.3 Test Procedure	41
4.2.4 Deviation from Test Standard	41
4.2.5 Test Setup	41
4.2.6 EUT Operating Condition	41
4.2.7 Test Results	42
4.3 Transmit Power Measurement	44
4.3.1 Limits of Transmit Power Measurement	44
4.3.2 Test Setup	44
4.3.3 Test Instruments	44
4.3.4 Test Procedure	44
4.3.5 Deviation from Test Standard	44
4.3.6 EUT Operating Condition	44
4.3.7 Test Result	45
4.4 Occupied Bandwidth Measurement	48
4.4.1 Test Setup	48
4.4.2 Test Instruments	48
4.4.3 Test Procedure	48
4.4.4 Test Results	48
4.5 Peak Power Spectral Density Measurement	53
4.5.1 Limits of Peak Power Spectral Density Measurement	53
4.5.2 Test Setup	53
4.5.3 Test Instruments	53
4.5.4 Test Procedure	53
4.5.5 Deviation from Test Standard	54
4.5.6 EUT Operating Condition	54
4.5.7 Test Results	55
4.6 Frequency Stability Measurement	61
4.6.1 Limits of Frequency Stability Measurement	61

4.6.2	Test Setup.....	61
4.6.3	Test Instruments	61
4.6.4	Test Procedure	61
4.6.5	Deviation from Test Standard	61
4.6.6	EUT Operating Condition	61
4.6.7	Test Results	62
4.7	6dB Bandwidth Measurement	63
4.7.1	Limits of 6dB Bandwidth Measurement.....	63
4.7.2	Test Setup.....	63
4.7.3	Test Instruments	63
4.7.4	Test Procedure	63
4.7.5	Deviation from Test Standard	63
4.7.6	EUT Operating Condition	63
4.7.7	Test Results	64
5	Pictures of Test Arrangements.....	66
	Annex A- Radiated Out of Band Emission (OOBE) Measurement (For U-NII-3 band)	67
	Appendix – Information on the Testing Laboratories	70

Release Control Record

Issue No.	Description	Date Issued
RF160706E06-1	Original release.	Sep. 20, 2016

1 Certificate of Conformity

Product: VDSL IAD

Brand: MitraStar

Test Model: DSL-2401HNA-T1CC

Sample Status: ENGINEERING SAMPLE

Applicant: MitraStar Technology Corporation

Test Date: July 20 to 29, 2016

Standard: 47 CFR FCC Part 15, Subpart E (Section 15.407)
ANSI C63.10: 2013

The above equipment has been tested by **Bureau Veritas Consumer Products Services (H.K.) Ltd., Taoyuan Branch**, and found compliance with the requirement of the above standards. The test record, data evaluation & Equipment Under Test (EUT) configurations represented herein are true and accurate accounts of the measurements of the sample's EMC characteristics under the conditions specified in this report.

Prepared by :  _____, **Date:** _____ Sep. 20, 2016
Wendy Wu / Specialist

Approved by :  _____, **Date:** _____ Sep. 20, 2016
May Chen / Manager

2 Summary of Test Results

47 CFR FCC Part 15, Subpart E (Section 15.407)			
FCC Clause	Test Item	Result	Remarks
15.407(b)(6)	AC Power Conducted Emissions	Pass	Meet the requirement of limit. Minimum passing margin is -10.24dB at 24.00000MHz.
15.407(b)(1/2/3/4(i/ii)/6)	Radiated Emissions & Band Edge Measurement*	Pass	Meet the requirement of limit. Minimum passing margin is -0.1dB at 11490.00MHz, 11650.00MHz, 5150.00MHz.
15.407(a)(1/2/3)	Max Average Transmit Power	Pass	Meet the requirement of limit.
---	Occupied Bandwidth Measurement	Pass	Meet the requirement of limit.
15.407(a)(1/2/3)	Peak Power Spectral Density	Pass	Meet the requirement of limit.
15.407(e)	6dB bandwidth	Pass	Meet the requirement of limit. (U-NII-3 Band only)
15.407(g)	Frequency Stability	Pass	Meet the requirement of limit.
15.203	Antenna Requirement	Pass	Antenna connector is i-pex(MHF) not a standard connector.

*For U-NII-3 band compliance with rule part 15.407(b)(4)(i), the OOB test plots were recorded in Annex A.

2.1 Measurement Uncertainty

Where relevant, the following measurement uncertainty levels have been estimated for tests performed on the EUT as specified in CISPR 16-4-2:

Measurement	Frequency	Expanded Uncertainty (k=2) (\pm)
Conducted Emissions at mains ports	150kHz ~ 30MHz	1.83 dB
Radiated Emissions up to 1 GHz	30MHz ~ 1GHz	5.13 dB
	1GHz ~ 6GHz	3.40 dB
Radiated Emissions above 1 GHz	6GHz ~ 18GHz	3.73 dB
	18GHz ~ 40GHz	4.11 dB

2.2 Modification Record

There were no modifications required for compliance.

3 General Information

3.1 General Description of EUT

Product	VDSL IAD
Brand	MitraStar
Test Model	DSL-2401HNA-T1CC
Status of EUT	ENGINEERING SAMPLE
Power Supply Rating	DC12V from power adapter
Modulation Type	CCK, DQPSK, DBPSK for DSSS 64QAM, 16QAM, QPSK, BPSK for OFDM 256QAM for OFDM in 11ac mode only
Modulation Technology	DSSS, OFDM
Transfer Rate	802.11b: up to 11Mbps 802.11a/g: up to 54Mbps 802.11n: up to 600Mbps 802.11ac: up to 1733.3Mbps
Operating Frequency	2.4GHz: 2.412GHz ~ 2.462GHz 5GHz: 5.18GHz ~ 5.24GHz, 5.745GHz ~ 5.825GHz
Number of Channel	2.4GHz: 802.11b, 802.11g, 802.11n (HT20): 11 802.11n (HT40): 7 5GHz: 802.11a, 802.11n (HT20), 802.11ac (VHT20): 9 802.11n (HT40), 802.11ac (VHT40): 4 802.11ac (VHT80): 2
Output Power	2.4GHz: 532.235mW 5GHz: 5.18GHz ~ 5.24GHz: CDD Mode: 348.899mW Beamforming Mode: 348.899mW 5.745GHz ~ 5.825GHz: CDD Mode: 413.705mW Beamforming Mode: 413.705mW
Antenna Type	Refer to Note
Antenna Connector	Refer to Note
Accessory Device	Adapter x 1
Data Cable Supplied	RJ-11 cable (unshielded, 1.5m) x 1 RJ-45 cable (unshielded, 1.5m) x 1

Note:

1. The EUT must be supplied with a power adapter as following table:

Brand	Model No.	Spec.
UMEC	UP0181D-12PA	Input: 100-240Vac, 50-60Hz, 0.4A Output: 12Vdc, 1.5A DC output cable (Unshielded, 1.5m)

2. Simultaneously transmission condition.

Condition	Technology	
1	WLAN (2.4GHz)	WLAN (5GHz)

Note: The emission of the simultaneous operation has been evaluated and no non-compliance was found.

3. The antennas provided to the EUT, please refer to the following table:

2.4GHz band								
Antenna Set.	Chain No.	Brand	Model	Antenna Gain(dBi)	Frequency range (GHz ~ GHz)	Antenna Type	Connector Type	Cable Length (mm)
1	Chain 0	Whayu	65-031-240136B	2.7	2.4~2.4835	PCB	NA	202
	Chain 1		65-031-240141B	3	2.4~2.4835		NA	75
5GHz band								
Antenna Set	Chain No.	Brand	Model	Antenna Gain(dBi)	Frequency range (GHz ~ GHz)	Antenna Type	Connector Type	Cable Length (mm)
1	Chain 0	Whayu	65-031-240137B	3.4	5.15~5.85	PCB	i-pex(MHF)	90
	Chain 1		65-031-240138B	3.3	5.15~5.85		i-pex(MHF)	115
	Chain 2		65-031-240139B	3.4	5.15~5.85		i-pex(MHF)	181
	Chain 3		65-031-240140B	3.4	5.15~5.85		i-pex(MHF)	200

4. The EUT incorporates a MIMO function.

2.4GHz Band			
MODULATION MODE	DATA RATE (MCS)	TX & RX CONFIGURATION	
802.11b	1 ~ 11Mbps	2TX	2RX
802.11g	6 ~ 54Mbps	2TX	2RX
802.11n (HT20)	MCS 0~7	2TX	2RX
	MCS 8~15	2TX	2RX
802.11n (HT40)	MCS 0~7	2TX	2RX
	MCS 8~15	2TX	2RX
5GHz Band			
MODULATION MODE	DATA RATE (MCS)	TX & RX CONFIGURATION	
802.11a	6 ~ 54Mbps	4TX	4RX
802.11n (HT20)	MCS 0~7	4TX	4RX
	MCS 8~15	4TX	4RX
	MCS 16~23	4TX	4RX
	MCS 24~31	4TX	4RX
802.11n (HT40)	MCS 0~7	4TX	4RX
	MCS 8~15	4TX	4RX
	MCS 16~23	4TX	4RX
	MCS 24~31	4TX	4RX
802.11ac (VHT20)	MCS0~8 Nss=1	2TX	2RX
	MCS0~8 Nss=2	2TX	2RX
	MCS0~9 Nss=3	4TX	4RX
	MCS0~8 Nss=4	4TX	4RX
802.11ac (VHT40)	MCS0~9 Nss=1	4TX	4RX
	MCS0~9 Nss=2	4TX	4RX
	MCS0~9 Nss=3	4TX	4RX
	MCS0~9 Nss=4	4TX	4RX
802.11ac (VHT80)	MCS0~9 Nss=1	4TX	4RX
	MCS0~9 Nss=2	4TX	4RX
	MCS0~9 Nss=3	4TX	4RX
	MCS0~9 Nss=4	4TX	4RX

Note:

- All of modulation mode support beamforming function except 802.11a modulation mode and 2.4GHz band.
- The modulation and bandwidth are similar for 802.11n mode for 20MHz (40MHz) and 802.11ac mode for 20MHz (40MHz), therefore investigated worst case to representative mode in test report. (Final test mode refer section 3.2.1)

5. The power setting are list as below:

CDD Mode				
Modulation Mode	Frequency (MHz)	Power Setting	Frequency (MHz)	Power Setting
802.11a	5180	19	5745	18
	5200	19	5785	18
	5240	19	5825	19
802.11ac (VHT20)	5180	19	5745	18
	5200	19	5785	18
	5240	19	5825	19
802.11ac (VHT40)	5190	16	5755	19
	5230	19	5795	19
802.11ac (VHT80)	5210	16	5775	19
Beamforming Mode				
Modulation Mode	Frequency (MHz)	Power Setting	Frequency (MHz)	Power Setting
802.11ac (VHT20)	5180	19	5745	18
	5200	19	5785	18
	5240	19	5825	19
802.11ac (VHT40)	5190	16	5755	19
	5230	19	5795	19
802.11ac (VHT80)	5210	16	5775	19

6. The above EUT information is declared by manufacturer and for more detailed features description, please refer to the manufacturer's specifications or user's manual.

3.2 Description of Test Modes

FOR 5180 ~ 5240MHz

4 channels are provided for 802.11a, 802.11n (HT20), 802.11ac (VHT20):

Channel	Frequency	Channel	Frequency
36	5180 MHz	44	5220 MHz
40	5200 MHz	48	5240 MHz

2 channels are provided for 802.11n (HT40), 802.11ac (VHT40):

Channel	Frequency	Channel	Frequency
38	5190 MHz	46	5230 MHz

1 channel is provided for 802.11ac (VHT80):

Channel	Frequency
42	5210MHz

FOR 5745 ~ 5825MHz:

5 channels are provided for 802.11a, 802.11n (HT20), 802.11ac (VHT20):

Channel	Frequency	Channel	Frequency
149	5745MHz	161	5805MHz
153	5765MHz	165	5825MHz
157	5785MHz		

2 channels are provided for 802.11n (HT40), 802.11ac (VHT40):

Channel	Frequency	Channel	Frequency
151	5755MHz	159	5795MHz

1 channel is provided for 802.11ac (VHT80):

Channel	Frequency
155	5775MHz

3.2.1 Test Mode Applicability and Tested Channel Detail

EUT Configure Mode	Applicable To				Description
	RE \geq 1G	RE<1G	PLC	APCM	
-	√	√	√	√	-

Where **RE \geq 1G**: Radiated Emission above 1GHz **RE<1G**: Radiated Emission below 1GHz
PLC: Power Line Conducted Emission **APCM**: Antenna Port Conducted Measurement

Radiated Emission Test (Above 1GHz):

- Pre-Scan has been conducted to determine the worst-case mode from all possible combinations between available modulations, data rates and antenna ports (if EUT with antenna diversity architecture).
- Following channel(s) was (were) selected for the final test as listed below.

CDD Mode						
Mode	FREQ. Band (MHz)	Available Channel	Tested Channel	Modulation Technology	Modulation Type	Data Rate (Mbps)
802.11a	5180-5240	36 to 48	36, 40, 48	OFDM	BPSK	6
802.11ac (VHT20)		36 to 48	36, 40, 48	OFDM	BPSK	6.5
802.11ac (VHT40)		38 to 46	38, 46	OFDM	BPSK	13.5
802.11ac (VHT80)		42	42	OFDM	BPSK	29.3
802.11a	5745-5825	149 to 165	149, 157, 165	OFDM	BPSK	6
802.11ac (VHT20)		149 to 165	149, 157, 165	OFDM	BPSK	6.5
802.11ac (VHT40)		151 to 159	151, 159	OFDM	BPSK	13.5
802.11ac (VHT80)		155	155	OFDM	BPSK	29.3

Radiated Emission Test (Below 1GHz):

- Pre-Scan has been conducted to determine the worst-case mode from all possible combinations between available modulations, data rates and antenna ports (if EUT with antenna diversity architecture).
- Following channel(s) was (were) selected for the final test as listed below.

CDD Mode						
Mode	FREQ. Band (MHz)	Available Channel	Tested Channel	Modulation Technology	Modulation Type	Data Rate (Mbps)
802.11ac (VHT40)	5745-5825	151 to 159	151	OFDM	BPSK	13.5

Power Line Conducted Emission Test:

- Pre-Scan has been conducted to determine the worst-case mode from all possible combinations between available modulations, data rates and antenna ports (if EUT with antenna diversity architecture).
- Following channel(s) was (were) selected for the final test as listed below.

CDD Mode						
Mode	FREQ. Band (MHz)	Available Channel	Tested Channel	Modulation Technology	Modulation Type	Data Rate (Mbps)
802.11ac (VHT40)	5745-5825	151 to 159	151	OFDM	BPSK	13.5

Antenna Port Conducted Measurement:

- This item includes all test value of each mode, but only includes spectrum plot of worst value of each mode.
- Pre-Scan has been conducted to determine the worst-case mode from all possible combinations between available modulations, data rates and antenna ports (if EUT with antenna diversity architecture).
- Following channel(s) was (were) selected for the final test as listed below.

CDD Mode						
Mode	FREQ. Band (MHz)	Available Channel	Tested Channel	Modulation Technology	Modulation Type	Data Rate (Mbps)
802.11a	5180-5240	36 to 48	36, 40, 48	OFDM	BPSK	6
802.11ac (VHT20)		36 to 48	36, 40, 48	OFDM	BPSK	6.5
802.11ac (VHT40)		38 to 46	38, 46	OFDM	BPSK	13.5
802.11ac (VHT80)		42	42	OFDM	BPSK	29.3
802.11a	5745-5825	149 to 165	149, 157, 165	OFDM	BPSK	6
802.11ac (VHT20)		149 to 165	149, 157, 165	OFDM	BPSK	6.5
802.11ac (VHT40)		151 to 159	151, 159	OFDM	BPSK	13.5
802.11ac (VHT80)		155	155	OFDM	BPSK	29.3
Beamforming Mode (Output power only)						
Mode	FREQ. Band (MHz)	Available Channel	Tested Channel	Modulation Technology	Modulation Type	Data Rate (Mbps)
802.11ac (VHT20)	5180-5240	36 to 48	36, 40, 48	OFDM	BPSK	6.5
802.11ac (VHT40)		38 to 46	38, 46	OFDM	BPSK	13.5
802.11ac (VHT80)		42	42	OFDM	BPSK	29.3
802.11ac (VHT20)	5745-5825	149 to 165	149, 157, 165	OFDM	BPSK	6.5
802.11ac (VHT40)		151 to 159	151, 159	OFDM	BPSK	13.5
802.11ac (VHT80)		155	155	OFDM	BPSK	29.3

Test Condition:

Applicable To	Environmental Conditions	Input Power	Tested By
RE \geq 1G	22deg. C, 69%RH	120Vac, 60Hz	Russell Yeh
RE $<$ 1G	22deg. C, 69%RH	120Vac, 60Hz	Robert Cheng
PLC	23deg. C, 62%RH	120Vac, 60Hz	Jyunchun Lin
APCM	25deg. C, 60%RH	120Vac, 60Hz	Anderson Chen

3.3 Duty Cycle of Test Signal

If duty cycle of test signal is $\geq 98\%$, duty factor is not required.

802.11a: Duty cycle = $3.288 \text{ ms} / 3.353 \text{ ms} = 0.981$

802.11ac (VHT20): Duty cycle = $30.125 \text{ ms} / 30.213 \text{ ms} = 0.997$

802.11ac (VHT40): Duty cycle = $14.544 \text{ ms} / 14.631 \text{ ms} = 0.994$

802.11ac (VHT80): Duty cycle = $6.708 \text{ ms} / 6.771 \text{ ms} = 0.991$

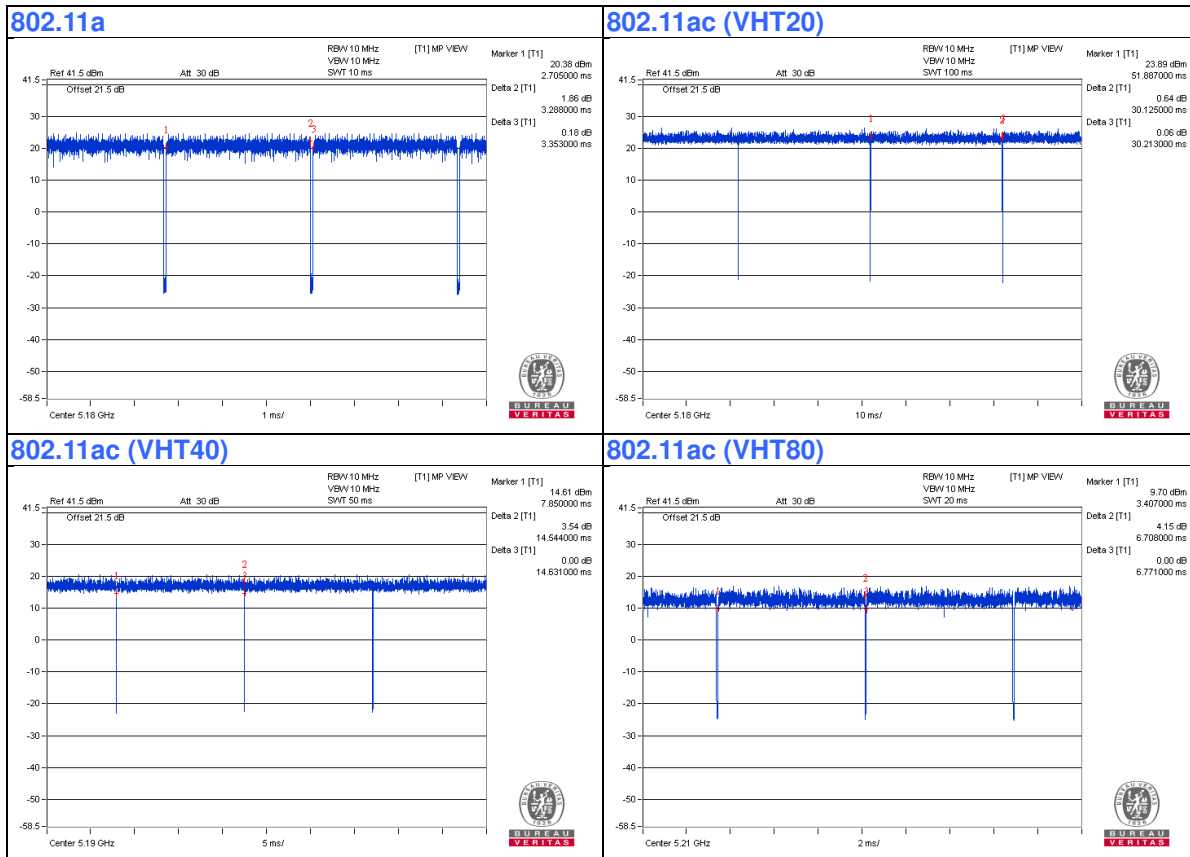

3.4 Description of Support Units

The EUT has been tested as an independent unit together with other necessary accessories or support units. The following support units or accessories were used to form a representative test configuration during the tests.

ID	Product	Brand	Model No.	Serial No.	FCC ID	Remarks
A.	Notebook Computer	DELL	E6440	H7LYQ32	FCC DoC	Provided by Lab
B.	Co-Router	ZyXEL	IES-1000	S08024701597	FCC DoC	Provided by Lab
C.	HUB	ZyXEL	ES-116P	S060H02000215	FCC DoC	Provided by Lab
D.	Telephone	DAISHO	DS-03	N/A	N/A	Provided by Lab

Note:

1. All power cords of the above support units are non-shielded (1.8m).

ID	Descriptions	Qty.	Length (m)	Shielding (Yes/No)	Cores (Qty.)	Remarks
1.	DC Cable	1	1.5	No	0	Supplied by client
2.	RJ-45 Cable	1	10	No	0	Provided by Lab
3.	RJ-45 Cable	3	10	No	0	Provided by Lab
4.	RJ-11 Cable	1	10	No	0	Provided by Lab
5.	RJ-11 Cable	1	10	No	0	Provided by Lab

3.4.1 Configuration of System under Test

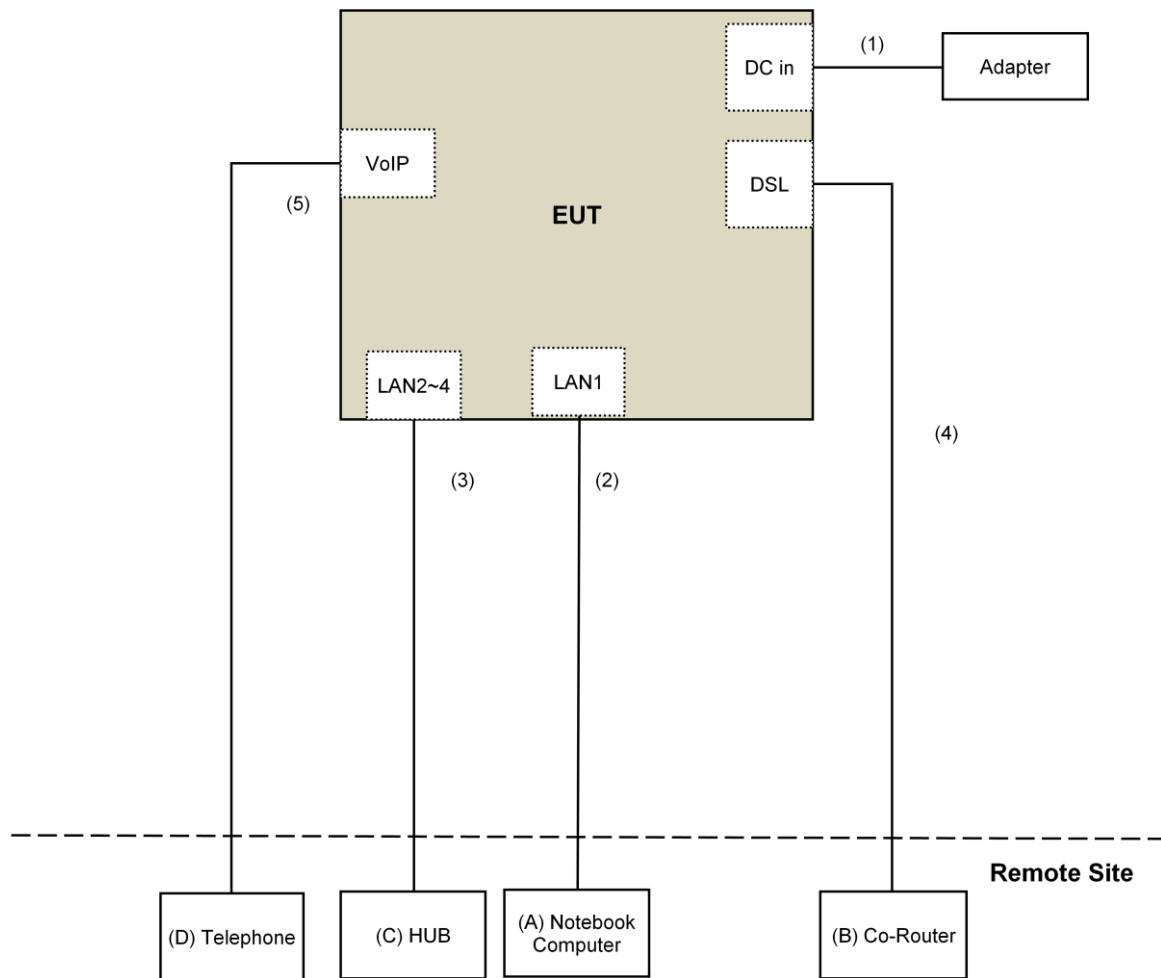

3.5 General Description of Applied Standard

The EUT is a RF Product. According to the specifications of the manufacturer, it must comply with the requirements of the following standards:

FCC Part 15, Subpart E (15.407)
KDB 789033 D02 General UNII Test Procedure New Rules v01r02
KDB 662911 D01 Multiple Transmitter Output v02r01
ANSI C63.10-2013

All test items have been performed and recorded as per the above standards.

NOTE: The EUT has been verified to comply with the requirements of FCC Part 15, Subpart B, Class B (DoC). The test report has been issued separately.

4 Test Types and Results

4.1 Radiated Emission and Bandedge Measurement

4.1.1 Limits of Radiated Emission and Bandedge Measurement

Radiated emissions which fall in the restricted bands must comply with the radiated emission limits specified as below table.

Frequencies (MHz)	Field Strength (microvolts/meter)	Measurement Distance (meters)
0.009 ~ 0.490	2400/F(kHz)	300
0.490 ~ 1.705	24000/F(kHz)	30
1.705 ~ 30.0	30	30
30 ~ 88	100	3
88 ~ 216	150	3
216 ~ 960	200	3
Above 960	500	3

NOTE:

1. The lower limit shall apply at the transition frequencies.
2. Emission level (dBuV/m) = 20 log Emission level (uV/m).
3. For frequencies above 1000MHz, the field strength limits are based on average detector, however, the peak field strength of any emission shall not exceed the maximum permitted average limits, specified above by more than 20dB under any condition of modulation.

Limits of unwanted emission out of the restricted bands

Applicable To		Limit	
789033 D02 General UNII Test Procedure New Rules v01r02		Field Strength at 3m	
		PK:74 (dBμV/m)	AV:54 (dBμV/m)
Frequency Band	Applicable To	EIRP Limit	Equivalent Field Strength at 3m
5150~5250 MHz	15.407(b)(1)	PK:-27 (dBm/MHz)	PK:68.2(dBμV/m)
5250~5350 MHz	15.407(b)(2)		
5470~5725 MHz	15.407(b)(3)		
5725~5850 MHz	<input checked="" type="checkbox"/> 15.407(b)(4)(i)	PK:-27 (dBm/MHz) ^{*1} PK:10 (dBm/MHz) ^{*2} PK:15.6 (dBm/MHz) ^{*3} PK:27 (dBm/MHz) ^{*4}	PK: 68.2(dBμV/m) ^{*1} PK:105.2 (dBμV/m) ^{*2} PK: 110.8(dBμV/m) ^{*3} PK:122.2 (dBμV/m) ^{*4}
	<input type="checkbox"/> 15.407(b)(4)(ii)	Emission limits in section 15.247(d)	
^{*1} beyond 75 MHz or more above of the band edge.		^{*2} below the band edge increasing linearly to 10 dBm/MHz at 25 MHz above.	
^{*3} below the band edge increasing linearly to a level of 15.6 dBm/MHz at 5 MHz above.		^{*4} from 5 MHz above or below the band edge increasing linearly to a level of 27 dBm/MHz at the band edge.	

Note:

The following formula is used to convert the equipment isotropic radiated power (eirp) to field strength:

$$E = \frac{1000000\sqrt{30P}}{3} \mu\text{V/m, where } P \text{ is the eirp (Watts).}$$

4.1.2 Test Instruments

DESCRIPTION & MANUFACTURER	MODEL NO.	SERIAL NO.	CALIBRATED DATE	CALIBRATED UNTIL
Test Receiver Agilent	N9038A	MY50010156	Aug. 12, 2015	Aug. 11, 2016
Pre-Amplifier ^(*) EMCI	EMC001340	980142	Jan. 20, 2016	Jan. 19, 2018
Loop Antenna ^(*) Electro-Metrics	EM-6879	264	Dec. 16, 2014	Dec. 15, 2016
RF Cable	NA	LOOPCAB-001 LOOPCAB-002	Jan. 18, 2016	Jan. 17, 2017
Pre-Amplifier Mini-Circuits	ZFL-1000VH2B	AMP-ZFL-05	May 07, 2016	May 06, 2017
Trilog Broadband Antenna SCHWARZBECK	VULB 9168	9168-156	Jan. 04, 2016	Jan. 03, 2017
RF Cable	8D	966-3-1 966-3-2 966-3-3	Apr. 02, 2016	Apr. 01, 2017
Horn_Antenna SCHWARZBECK	BBHA9120-D	9120D-406	Jan. 20, 2016	Jan. 19, 2017
Pre-Amplifier Agilent	8449B	3008A02465	Apr. 05, 2016	Apr. 04, 2017
RF Cable	EMC104-SM-SM-2000 EMC104-SM-SM-5000 EMC104-SM-SM-5000	150317 150321 150322	Mar. 30, 2016	Mar. 29, 2017
Test Receiver Keysight	N9038A	MY54450088	July 20, 2016	July 19, 2017
Pre-Amplifier EMCI	EMC184045	980143	Jan. 15, 2016	Jan. 14, 2017
Horn_Antenna SCHWARZBECK	BBHA 9170	BBHA9170608	Jan. 08, 2016	Jan. 07, 2017
RF Cable	SUCOFLEX 102	36432/2 36441/2	Jan. 16, 2016	Jan. 15, 2017
Software	ADT_Radiated_V8.7.07	NA	NA	NA
Antenna Tower & Turn Table Max-Full	MF-7802	MF780208406	NA	NA
Boresight Antenna Fixture	FBA-01	FBA-SIP01	NA	NA
Spectrum Analyzer R&S	FSP40	100060	May 11, 2016	May 10, 2017
Power meter Anritsu	ML2495A	1014008	May 5, 2016	May 4, 2017
Power sensor Anritsu	MA2411B	0917122	May 5, 2016	May 4, 2017
Temperature & Humidity Chamber Giant Force	GTH-150-40-SP-AR	MAA0812-008	Jan. 15, 2016	Jan. 14, 2017
AC Power Source Extech Electronics	6205	1440452	NA	NA
Digital Multimeter FLUKE	87III	73680266	Nov. 10, 2015	Nov. 09, 2016

Note:

1. The calibration interval of the above test instruments is 12 months and the calibrations are traceable to NML/ROC and NIST/USA.
2. *The calibration interval of the above test instruments is 24 months and the calibrations are traceable to NML/ROC and NIST/USA.
3. The test was performed in 966 Chamber No. 3.
4. The FCC Site Registration No. is 147459
5. Loop antenna was used for all emissions below 30 MHz.
6. The CANADA Site Registration No. is 20331-1
7. Tested Date: July 27 to 29, 2016

4.1.3 Test Procedure

- a. The EUT was placed on the top of a rotating table 0.8 meters (for below 1GHz) / 1.5 meters (for above 1GHz) above the ground at 3 meter chamber room for test. The table was rotated 360 degrees to determine the position of the highest radiation.
- b. The EUT was set 3 meters away from the interference-receiving antenna, which was mounted on the top of a variable-height antenna tower.
- c. The height of antenna is varied from one meter to four meters above the ground to determine the maximum value of the field strength. Both horizontal and vertical polarizations of the antenna are set to make the measurement.
- d. For each suspected emission, the EUT was arranged to its worst case and then the antenna was tuned to heights from 1 meter to 4 meters and the rotatable table was turned from 0 degrees to 360 degrees to find the maximum reading.
- e. The test-receiver system was set to quasi-peak detect function and specified bandwidth with maximum hold mode when the test frequency is below 1 GHz.
- f. The test-receiver system was set to peak and average detect function and specified bandwidth with maximum hold mode when the test frequency is above 1 GHz. If the peak reading value also meets average limit, measurement with the average detector is unnecessary.

Note:

1. The resolution bandwidth and video bandwidth of test receiver/spectrum analyzer is 120kHz for Quasi-peak detection (QP) at frequency below 1GHz.
2. The resolution bandwidth of test receiver/spectrum analyzer is 1 MHz and the video bandwidth is 3 MHz for Peak detection (PK) at frequency above 1GHz.
3. The resolution bandwidth of test receiver/spectrum analyzer is 1MHz and the video bandwidth is 3MHz for RMS Average (Duty cycle < 98%) for Average detection (AV) at frequency above 1GHz, then the measurement results was added to a correction factor ($10 \log(1/\text{duty cycle})$).
4. The resolution bandwidth of test receiver/spectrum analyzer is 1MHz and the video bandwidth is 10Hz (Duty cycle $\geq 98\%$) for Average detection (AV) at frequency above 1GHz.
5. All modes of operation were investigated and the worst-case emissions are reported.

4.1.4 Deviation from Test Standard

No deviation.

4.1.5 Test Setup

<Frequency Range below 1GHz>

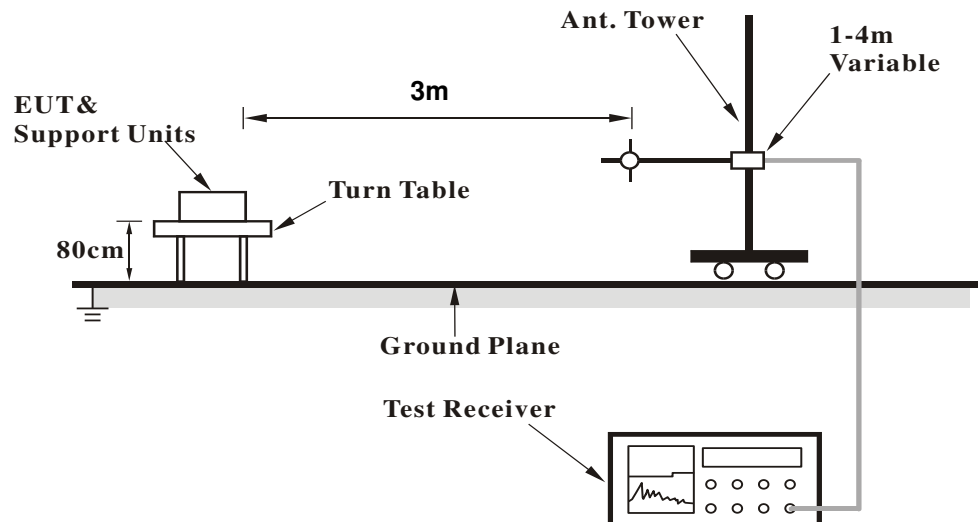

<Frequency Range above 1GHz>

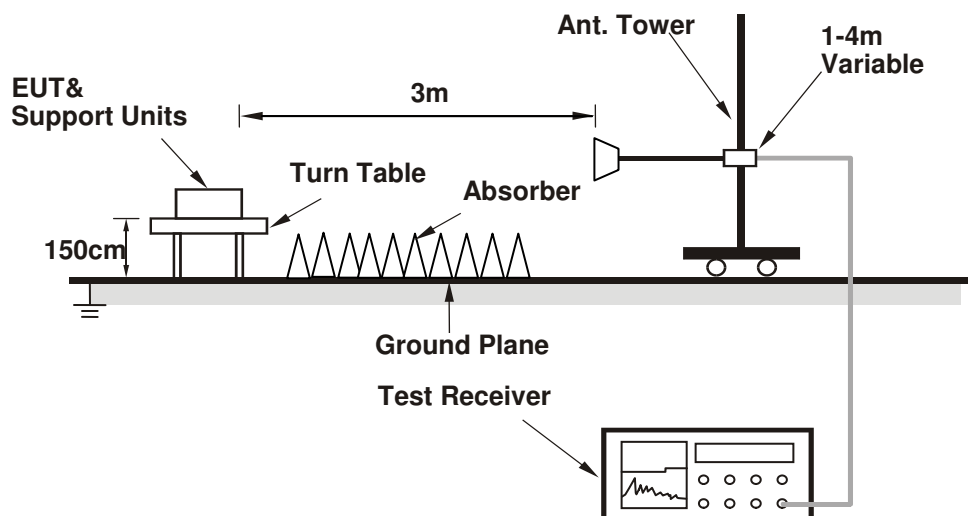

For the actual test configuration, please refer to the attached file (Test Setup Photo).

4.1.6 EUT Operating Condition

- a. Connected the EUT with the Notebook Computer which is placed on remote site.
- b. Controlling software (Telnet paste "DSL-2401HNA-T1CC_5G setup SOP.txt" command) has been activated to set the EUT on specific status.

4.1.7 Test Results

Above 1GHz Data:

802.11a

CHANNEL	TX Channel 36	DETECTOR FUNCTION	Peak (PK)
FREQUENCY RANGE	1GHz ~ 40GHz		Average (AV)

ANTENNA POLARITY & TEST DISTANCE: HORIZONTAL AT 3 M								
NO.	FREQ. (MHz)	EMISSION LEVEL (dBuV/m)	LIMIT (dBuV/m)	MARGIN (dB)	ANTENNA HEIGHT (m)	TABLE ANGLE (Degree)	RAW VALUE (dBuV)	CORRECTION FACTOR (dB/m)
1	5150.00	68.1 PK	74.0	-5.9	1.79 H	173	65.1	3.0
2	5150.00	50.5 AV	54.0	-3.5	1.79 H	173	47.5	3.0
3	*5180.00	115.6 PK			1.79 H	173	112.5	3.1
4	*5180.00	106.0 AV			1.79 H	173	102.9	3.1
5	#10360.00	63.8 PK	74.0	-10.2	1.86 H	287	50.2	13.6
6	#10360.00	50.5 AV	54.0	-3.5	1.86 H	287	36.9	13.6
7	15540.00	57.8 PK	74.0	-16.2	2.16 H	39	42.1	15.7
8	15540.00	46.0 AV	54.0	-8.0	2.16 H	39	30.3	15.7

ANTENNA POLARITY & TEST DISTANCE: VERTICAL AT 3 M								
NO.	FREQ. (MHz)	EMISSION LEVEL (dBuV/m)	LIMIT (dBuV/m)	MARGIN (dB)	ANTENNA HEIGHT (m)	TABLE ANGLE (Degree)	RAW VALUE (dBuV)	CORRECTION FACTOR (dB/m)
1	5150.00	62.3 PK	74.0	-11.7	1.87 V	91	59.3	3.0
2	5150.00	49.1 AV	54.0	-4.9	1.87 V	91	46.1	3.0
3	*5180.00	116.5 PK			1.87 V	91	113.4	3.1
4	*5180.00	105.8 AV			1.87 V	91	102.7	3.1
5	#10360.00	63.5 PK	74.0	-10.5	1.50 V	347	49.9	13.6
6	#10360.00	49.3 AV	54.0	-4.7	1.50 V	347	35.7	13.6
7	15540.00	56.0 PK	74.0	-18.0	1.55 V	299	40.3	15.7
8	15540.00	43.6 AV	54.0	-10.4	1.55 V	299	27.9	15.7

REMARKS:

1. Emission Level(dBuV/m) = Raw Value(dBuV) + Correction Factor(dB/m)
2. Correction Factor(dB/m) = Antenna Factor(dB/m) + Cable Factor(dB) – Pre-Amplifier Factor(dB)
3. The other emission levels were very low against the limit.
4. Margin value = Emission Level – Limit value
5. " * ": Fundamental frequency.
6. " # ": The radiated frequency is out of the restricted band.

CHANNEL	TX Channel 40	DETECTOR FUNCTION	Peak (PK)
FREQUENCY RANGE	1GHz ~ 40GHz		Average (AV)

ANTENNA POLARITY & TEST DISTANCE: HORIZONTAL AT 3 M

NO.	FREQ. (MHz)	EMISSION LEVEL (dBuV/m)	LIMIT (dBuV/m)	MARGIN (dB)	ANTENNA HEIGHT (m)	TABLE ANGLE (Degree)	RAW VALUE (dBuV)	CORRECTION FACTOR (dB/m)
1	*5200.00	116.2 PK			1.78 H	179	113.1	3.1
2	*5200.00	106.3 AV			1.78 H	179	103.2	3.1
3	#10400.00	63.1 PK	74.0	-10.9	1.89 H	278	49.5	13.6
4	#10400.00	50.3 AV	54.0	-3.7	1.89 H	278	36.7	13.6
5	15600.00	57.7 PK	74.0	-16.3	2.20 H	46	42.0	15.7
6	15600.00	45.8 AV	54.0	-8.2	2.20 H	46	30.1	15.7

ANTENNA POLARITY & TEST DISTANCE: VERTICAL AT 3 M

NO.	FREQ. (MHz)	EMISSION LEVEL (dBuV/m)	LIMIT (dBuV/m)	MARGIN (dB)	ANTENNA HEIGHT (m)	TABLE ANGLE (Degree)	RAW VALUE (dBuV)	CORRECTION FACTOR (dB/m)
1	*5200.00	116.4 PK			1.93 V	84	113.3	3.1
2	*5200.00	105.6 AV			1.93 V	84	102.5	3.1
3	#10400.00	63.2 PK	74.0	-10.8	1.48 V	356	49.6	13.6
4	#10400.00	48.9 AV	54.0	-5.1	1.48 V	356	35.3	13.6
5	15600.00	56.2 PK	74.0	-17.8	1.53 V	310	40.5	15.7
6	15600.00	43.7 AV	54.0	-10.3	1.53 V	310	28.0	15.7

REMARKS:

1. Emission Level(dBuV/m) = Raw Value(dBuV) + Correction Factor(dB/m)
2. Correction Factor(dB/m) = Antenna Factor(dB/m) + Cable Factor(dB) – Pre-Amplifier Factor(dB)
3. The other emission levels were very low against the limit.
4. Margin value = Emission Level – Limit value
5. " * ": Fundamental frequency.
6. " # ": The radiated frequency is out of the restricted band.

CHANNEL	TX Channel 48	DETECTOR FUNCTION	Peak (PK)
FREQUENCY RANGE	1GHz ~ 40GHz		Average (AV)

ANTENNA POLARITY & TEST DISTANCE: HORIZONTAL AT 3 M

NO.	FREQ. (MHz)	EMISSION LEVEL (dBuV/m)	LIMIT (dBuV/m)	MARGIN (dB)	ANTENNA HEIGHT (m)	TABLE ANGLE (Degree)	RAW VALUE (dBuV)	CORRECTION FACTOR (dB/m)
1	*5240.00	115.3 PK			1.73 H	163	112.1	3.2
2	*5240.00	105.6 AV			1.73 H	163	102.4	3.2
3	5350.00	55.9 PK	74.0	-18.1	1.73 H	163	52.4	3.5
4	5350.00	42.8 AV	54.0	-11.2	1.73 H	163	39.3	3.5
5	#10480.00	63.2 PK	74.0	-10.8	1.84 H	283	49.2	14.0
6	#10480.00	50.1 AV	54.0	-3.9	1.84 H	283	36.1	14.0
7	15720.00	57.4 PK	74.0	-16.6	2.17 H	32	42.0	15.4
8	15720.00	45.5 AV	54.0	-8.5	2.17 H	32	30.1	15.4

ANTENNA POLARITY & TEST DISTANCE: VERTICAL AT 3 M

NO.	FREQ. (MHz)	EMISSION LEVEL (dBuV/m)	LIMIT (dBuV/m)	MARGIN (dB)	ANTENNA HEIGHT (m)	TABLE ANGLE (Degree)	RAW VALUE (dBuV)	CORRECTION FACTOR (dB/m)
1	*5240.00	116.3 PK			1.88 V	87	113.1	3.2
2	*5240.00	105.9 AV			1.88 V	87	102.7	3.2
3	5350.00	55.3 PK	74.0	-18.7	1.88 V	87	51.8	3.5
4	5350.00	42.4 AV	54.0	-11.6	1.88 V	87	38.9	3.5
5	#10480.00	63.1 PK	74.0	-10.9	1.53 V	358	49.1	14.0
6	#10480.00	48.9 AV	54.0	-5.1	1.53 V	358	34.9	14.0
7	15720.00	56.0 PK	74.0	-18.0	1.55 V	309	40.6	15.4
8	15720.00	43.6 AV	54.0	-10.4	1.55 V	309	28.2	15.4

REMARKS:

1. Emission Level(dBuV/m) = Raw Value(dBuV) + Correction Factor(dB/m)
2. Correction Factor(dB/m) = Antenna Factor(dB/m) + Cable Factor(dB) – Pre-Amplifier Factor(dB)
3. The other emission levels were very low against the limit.
4. Margin value = Emission Level – Limit value
5. " * ": Fundamental frequency.
6. " # ": The radiated frequency is out of the restricted band.

CHANNEL	TX Channel 149	DETECTOR FUNCTION	Peak (PK)
FREQUENCY RANGE	1GHz ~ 40GHz		Average (AV)

ANTENNA POLARITY & TEST DISTANCE: HORIZONTAL AT 3 M

NO.	FREQ. (MHz)	EMISSION LEVEL (dBuV/m)	LIMIT (dBuV/m)	MARGIN (dB)	ANTENNA HEIGHT (m)	TABLE ANGLE (Degree)	RAW VALUE (dBuV)	CORRECTION FACTOR (dB/m)
1	#5616.02	57.2 PK	68.2	-11.0	1.74 H	170	53.3	3.9
2	*5745.00	115.9 PK			1.74 H	170	111.7	4.2
3	*5745.00	105.8 AV			1.74 H	170	101.6	4.2
4	#5927.62	56.3 PK	68.2	-11.9	1.74 H	170	51.9	4.4
5	11490.00	68.5 PK	74.0	-5.5	1.36 H	7	53.3	15.2
6	11490.00	53.9 AV	54.0	-0.1	1.36 H	7	38.7	15.2
7	#17235.00	64.1 PK	74.0	-9.9	2.37 H	46	44.1	20.0
8	#17235.00	51.6 AV	54.0	-2.4	2.37 H	46	31.6	20.0

ANTENNA POLARITY & TEST DISTANCE: VERTICAL AT 3 M

NO.	FREQ. (MHz)	EMISSION LEVEL (dBuV/m)	LIMIT (dBuV/m)	MARGIN (dB)	ANTENNA HEIGHT (m)	TABLE ANGLE (Degree)	RAW VALUE (dBuV)	CORRECTION FACTOR (dB/m)
1	#5615.55	57.0 PK	68.2	-11.2	1.76 V	175	53.1	3.9
2	*5745.00	116.8 PK			1.76 V	175	112.6	4.2
3	*5745.00	105.7 AV			1.76 V	175	101.5	4.2
4	#5927.62	57.9 PK	68.2	-10.3	1.76 V	175	53.5	4.4
5	11490.00	68.1 PK	74.0	-5.9	1.44 V	12	52.9	15.2
6	11490.00	53.8 AV	54.0	-0.2	1.44 V	12	38.6	15.2
7	#17235.00	60.8 PK	74.0	-13.2	2.94 V	52	40.8	20.0
8	#17235.00	48.4 AV	54.0	-5.6	2.94 V	52	28.4	20.0

REMARKS:

1. Emission Level(dBuV/m) = Raw Value(dBuV) + Correction Factor(dB/m)
2. Correction Factor(dB/m) = Antenna Factor(dB/m) + Cable Factor(dB) – Pre-Amplifier Factor(dB)
3. The other emission levels were very low against the limit.
4. Margin value = Emission Level – Limit value
5. " * ": Fundamental frequency.
6. " # ": The radiated frequency is out of the restricted band.

CHANNEL	TX Channel 157	DETECTOR FUNCTION	Peak (PK)
FREQUENCY RANGE	1GHz ~ 40GHz		Average (AV)

ANTENNA POLARITY & TEST DISTANCE: HORIZONTAL AT 3 M

NO.	FREQ. (MHz)	EMISSION LEVEL (dBuV/m)	LIMIT (dBuV/m)	MARGIN (dB)	ANTENNA HEIGHT (m)	TABLE ANGLE (Degree)	RAW VALUE (dBuV)	CORRECTION FACTOR (dB/m)
1	#5640.73	56.7 PK	68.2	-11.5	1.77 H	188	52.7	4.0
2	*5785.00	114.4 PK			1.77 H	188	110.3	4.1
3	*5785.00	104.7 AV			1.77 H	188	100.6	4.1
4	#5965.15	56.5 PK	68.2	-11.7	1.77 H	188	52.0	4.5
5	11570.00	65.3 PK	74.0	-8.7	1.37 H	9	50.2	15.1
6	11570.00	52.8 AV	54.0	-1.2	1.37 H	9	37.7	15.1
7	#17355.00	63.5 PK	74.0	-10.5	2.43 H	46	43.0	20.5
8	#17355.00	51.3 AV	54.0	-2.7	2.43 H	46	30.8	20.5

ANTENNA POLARITY & TEST DISTANCE: VERTICAL AT 3 M

NO.	FREQ. (MHz)	EMISSION LEVEL (dBuV/m)	LIMIT (dBuV/m)	MARGIN (dB)	ANTENNA HEIGHT (m)	TABLE ANGLE (Degree)	RAW VALUE (dBuV)	CORRECTION FACTOR (dB/m)
1	#5603.68	56.6 PK	68.2	-11.6	1.83 V	155	52.7	3.9
2	*5785.00	114.8 PK			1.83 V	155	110.7	4.1
3	*5785.00	104.8 AV			1.83 V	155	100.7	4.1
4	#5948.52	59.0 PK	68.2	-9.2	1.83 V	155	54.6	4.4
5	11570.00	65.1 PK	74.0	-8.9	1.45 V	17	50.0	15.1
6	11570.00	52.7 AV	54.0	-1.3	1.45 V	17	37.6	15.1
7	#17355.00	61.0 PK	74.0	-13.0	2.88 V	57	40.5	20.5
8	#17355.00	48.5 AV	54.0	-5.5	2.88 V	57	28.0	20.5

REMARKS:

1. Emission Level(dBuV/m) = Raw Value(dBuV) + Correction Factor(dB/m)
2. Correction Factor(dB/m) = Antenna Factor(dB/m) + Cable Factor(dB) – Pre-Amplifier Factor(dB)
3. The other emission levels were very low against the limit.
4. Margin value = Emission Level – Limit value
5. " * ": Fundamental frequency.
6. " # ": The radiated frequency is out of the restricted band.

CHANNEL	TX Channel 165	DETECTOR FUNCTION	Peak (PK)
FREQUENCY RANGE	1GHz ~ 40GHz		Average (AV)

ANTENNA POLARITY & TEST DISTANCE: HORIZONTAL AT 3 M

NO.	FREQ. (MHz)	EMISSION LEVEL (dBuV/m)	LIMIT (dBuV/m)	MARGIN (dB)	ANTENNA HEIGHT (m)	TABLE ANGLE (Degree)	RAW VALUE (dBuV)	CORRECTION FACTOR (dB/m)
1	#5633.60	56.5 PK	68.2	-11.7	1.76 H	176	52.5	4.0
2	*5825.00	115.6 PK			1.76 H	176	111.4	4.2
3	*5825.00	105.9 AV			1.76 H	176	101.7	4.2
4	#5980.35	57.4 PK	68.2	-10.8	1.76 H	176	52.9	4.5
5	11650.00	68.6 PK	74.0	-5.4	1.36 H	10	53.6	15.0
6	11650.00	53.9 AV	54.0	-0.1	1.36 H	10	38.9	15.0
7	#17475.00	67.6 PK	74.0	-6.4	1.64 H	46	46.5	21.1
8	#17475.00	53.8 AV	54.0	-0.2	1.64 H	46	32.7	21.1

ANTENNA POLARITY & TEST DISTANCE: VERTICAL AT 3 M

NO.	FREQ. (MHz)	EMISSION LEVEL (dBuV/m)	LIMIT (dBuV/m)	MARGIN (dB)	ANTENNA HEIGHT (m)	TABLE ANGLE (Degree)	RAW VALUE (dBuV)	CORRECTION FACTOR (dB/m)
1	#5640.73	57.1 PK	68.2	-11.1	1.81 V	161	53.1	4.0
2	*5825.00	115.1 PK			1.81 V	161	110.9	4.2
3	*5825.00	105.1 AV			1.81 V	161	100.9	4.2
4	#5930.48	59.5 PK	68.2	-8.7	1.81 V	161	55.1	4.4
5	11650.00	67.8 PK	74.0	-6.2	1.74 V	16	52.8	15.0
6	11650.00	53.8 AV	54.0	-0.2	1.74 V	16	38.8	15.0
7	#17475.00	61.8 PK	74.0	-12.2	2.91 V	53	40.7	21.1
8	#17475.00	49.2 AV	54.0	-4.8	2.91 V	53	28.1	21.1

REMARKS:

1. Emission Level(dBuV/m) = Raw Value(dBuV) + Correction Factor(dB/m)
2. Correction Factor(dB/m) = Antenna Factor(dB/m) + Cable Factor(dB) – Pre-Amplifier Factor(dB)
3. The other emission levels were very low against the limit.
4. Margin value = Emission Level – Limit value
5. " * ": Fundamental frequency.
6. " # ": The radiated frequency is out of the restricted band.

802.11ac (VHT20)

CHANNEL	TX Channel 36	DETECTOR FUNCTION	Peak (PK)
FREQUENCY RANGE	1GHz ~ 40GHz		Average (AV)

ANTENNA POLARITY & TEST DISTANCE: HORIZONTAL AT 3 M

NO.	FREQ. (MHz)	EMISSION LEVEL (dBuV/m)	LIMIT (dBuV/m)	MARGIN (dB)	ANTENNA HEIGHT (m)	TABLE ANGLE (Degree)	RAW VALUE (dBuV)	CORRECTION FACTOR (dB/m)
1	5150.00	67.1 PK	74.0	-6.9	1.81 H	160	64.1	3.0
2	5150.00	51.2 AV	54.0	-2.8	1.81 H	160	48.2	3.0
3	*5180.00	116.6 PK			1.81 H	160	113.5	3.1
4	*5180.00	106.9 AV			1.81 H	160	103.8	3.1
5	#10360.00	63.1 PK	74.0	-10.9	1.81 H	285	49.5	13.6
6	#10360.00	50.2 AV	54.0	-3.8	1.81 H	285	36.6	13.6
7	15540.00	57.7 PK	74.0	-16.3	2.15 H	35	42.0	15.7
8	15540.00	45.5 AV	54.0	-8.5	2.15 H	35	29.8	15.7

ANTENNA POLARITY & TEST DISTANCE: VERTICAL AT 3 M

NO.	FREQ. (MHz)	EMISSION LEVEL (dBuV/m)	LIMIT (dBuV/m)	MARGIN (dB)	ANTENNA HEIGHT (m)	TABLE ANGLE (Degree)	RAW VALUE (dBuV)	CORRECTION FACTOR (dB/m)
1	5150.00	66.6 PK	74.0	-7.4	1.83 V	93	63.6	3.0
2	5150.00	50.8 AV	54.0	-3.2	1.83 V	93	47.8	3.0
3	*5180.00	116.2 PK			1.83 V	93	113.1	3.1
4	*5180.00	106.7 AV			1.83 V	93	103.6	3.1
5	#10360.00	63.1 PK	74.0	-10.9	1.52 V	344	49.5	13.6
6	#10360.00	49.2 AV	54.0	-4.8	1.52 V	344	35.6	13.6
7	15540.00	56.5 PK	74.0	-17.5	1.51 V	296	40.8	15.7
8	15540.00	44.0 AV	54.0	-10.0	1.51 V	296	28.3	15.7

REMARKS:

- Emission Level(dBuV/m) = Raw Value(dBuV) + Correction Factor(dB/m)
- Correction Factor(dB/m) = Antenna Factor(dB/m) + Cable Factor(dB) – Pre-Amplifier Factor(dB)
- The other emission levels were very low against the limit.
- Margin value = Emission Level – Limit value
- " * ": Fundamental frequency.
- " # ": The radiated frequency is out of the restricted band.

CHANNEL	TX Channel 40	DETECTOR FUNCTION	Peak (PK)
FREQUENCY RANGE	1GHz ~ 40GHz		Average (AV)

ANTENNA POLARITY & TEST DISTANCE: HORIZONTAL AT 3 M

NO.	FREQ. (MHz)	EMISSION LEVEL (dBuV/m)	LIMIT (dBuV/m)	MARGIN (dB)	ANTENNA HEIGHT (m)	TABLE ANGLE (Degree)	RAW VALUE (dBuV)	CORRECTION FACTOR (dB/m)
1	*5200.00	116.9 PK			1.76 H	162	113.8	3.1
2	*5200.00	107.1 AV			1.76 H	162	104.0	3.1
3	#10400.00	62.7 PK	74.0	-11.3	1.81 H	296	49.1	13.6
4	#10400.00	49.6 AV	54.0	-4.4	1.81 H	296	36.0	13.6
5	15600.00	57.6 PK	74.0	-16.4	2.15 H	41	41.9	15.7
6	15600.00	45.7 AV	54.0	-8.3	2.15 H	41	30.0	15.7

ANTENNA POLARITY & TEST DISTANCE: VERTICAL AT 3 M

NO.	FREQ. (MHz)	EMISSION LEVEL (dBuV/m)	LIMIT (dBuV/m)	MARGIN (dB)	ANTENNA HEIGHT (m)	TABLE ANGLE (Degree)	RAW VALUE (dBuV)	CORRECTION FACTOR (dB/m)
1	*5200.00	116.3 PK			1.92 V	89	113.2	3.1
2	*5200.00	106.5 AV			1.92 V	89	103.4	3.1
3	#10400.00	63.3 PK	74.0	-10.7	1.50 V	360	49.7	13.6
4	#10400.00	49.0 AV	54.0	-5.0	1.50 V	360	35.4	13.6
5	15600.00	56.1 PK	74.0	-17.9	1.52 V	306	40.4	15.7
6	15600.00	43.8 AV	54.0	-10.2	1.52 V	306	28.1	15.7

REMARKS:

1. Emission Level(dBuV/m) = Raw Value(dBuV) + Correction Factor(dB/m)
2. Correction Factor(dB/m) = Antenna Factor(dB/m) + Cable Factor(dB) – Pre-Amplifier Factor(dB)
3. The other emission levels were very low against the limit.
4. Margin value = Emission Level – Limit value
5. " * ": Fundamental frequency.
6. " # ": The radiated frequency is out of the restricted band.

CHANNEL	TX Channel 48	DETECTOR FUNCTION	Peak (PK)
FREQUENCY RANGE	1GHz ~ 40GHz		Average (AV)

ANTENNA POLARITY & TEST DISTANCE: HORIZONTAL AT 3 M

NO.	FREQ. (MHz)	EMISSION LEVEL (dBuV/m)	LIMIT (dBuV/m)	MARGIN (dB)	ANTENNA HEIGHT (m)	TABLE ANGLE (Degree)	RAW VALUE (dBuV)	CORRECTION FACTOR (dB/m)
1	*5240.00	116.7 PK			1.76 H	163	113.5	3.2
2	*5240.00	106.9 AV			1.76 H	163	103.7	3.2
3	5350.00	55.9 PK	74.0	-18.1	1.76 H	163	52.4	3.5
4	5350.00	43.2 AV	54.0	-10.8	1.76 H	163	39.7	3.5
5	#10480.00	63.0 PK	74.0	-11.0	1.80 H	278	49.0	14.0
6	#10480.00	49.9 AV	54.0	-4.1	1.80 H	278	35.9	14.0
7	15720.00	57.1 PK	74.0	-16.9	2.22 H	27	41.7	15.4
8	15720.00	45.1 AV	54.0	-8.9	2.22 H	27	29.7	15.4

ANTENNA POLARITY & TEST DISTANCE: VERTICAL AT 3 M

NO.	FREQ. (MHz)	EMISSION LEVEL (dBuV/m)	LIMIT (dBuV/m)	MARGIN (dB)	ANTENNA HEIGHT (m)	TABLE ANGLE (Degree)	RAW VALUE (dBuV)	CORRECTION FACTOR (dB/m)
1	*5240.00	115.9 PK			1.89 V	97	112.7	3.2
2	*5240.00	106.6 AV			1.89 V	97	103.4	3.2
3	5350.00	55.4 PK	74.0	-18.6	1.89 V	97	51.9	3.5
4	5350.00	42.7 AV	54.0	-11.3	1.89 V	97	39.2	3.5
5	#10480.00	63.7 PK	74.0	-10.3	1.52 V	352	49.7	14.0
6	#10480.00	49.2 AV	54.0	-4.8	1.52 V	352	35.2	14.0
7	15720.00	56.2 PK	74.0	-17.8	1.53 V	306	40.8	15.4
8	15720.00	43.6 AV	54.0	-10.4	1.53 V	306	28.2	15.4

REMARKS:

1. Emission Level(dBuV/m) = Raw Value(dBuV) + Correction Factor(dB/m)
2. Correction Factor(dB/m) = Antenna Factor(dB/m) + Cable Factor(dB) – Pre-Amplifier Factor(dB)
3. The other emission levels were very low against the limit.
4. Margin value = Emission Level – Limit value
5. " * ": Fundamental frequency.
6. " # ": The radiated frequency is out of the restricted band.

CHANNEL	TX Channel 149	DETECTOR FUNCTION	Peak (PK)
FREQUENCY RANGE	1GHz ~ 40GHz		Average (AV)

ANTENNA POLARITY & TEST DISTANCE: HORIZONTAL AT 3 M

NO.	FREQ. (MHz)	EMISSION LEVEL (dBuV/m)	LIMIT (dBuV/m)	MARGIN (dB)	ANTENNA HEIGHT (m)	TABLE ANGLE (Degree)	RAW VALUE (dBuV)	CORRECTION FACTOR (dB/m)
1	#5629.32	57.1 PK	68.2	-11.1	1.84 H	164	53.1	4.0
2	*5745.00	115.8 PK			1.81 H	177	111.6	4.2
3	*5745.00	105.9 AV			1.81 H	177	101.7	4.2
4	#5936.65	57.6 PK	68.2	-10.6	1.84 H	164	53.2	4.4
5	11490.00	68.2 PK	74.0	-5.8	1.40 H	22	53.0	15.2
6	11490.00	53.8 AV	54.0	-0.2	1.40 H	22	38.6	15.2
7	#17235.00	63.8 PK	74.0	-10.2	2.34 H	33	43.8	20.0
8	#17235.00	51.3 AV	54.0	-2.7	2.34 H	33	31.3	20.0

ANTENNA POLARITY & TEST DISTANCE: VERTICAL AT 3 M

NO.	FREQ. (MHz)	EMISSION LEVEL (dBuV/m)	LIMIT (dBuV/m)	MARGIN (dB)	ANTENNA HEIGHT (m)	TABLE ANGLE (Degree)	RAW VALUE (dBuV)	CORRECTION FACTOR (dB/m)
1	#5601.77	56.5 PK	68.2	-11.7	1.93 V	80	52.6	3.9
2	*5745.00	116.8 PK			1.92 V	86	112.6	4.2
3	*5745.00	106.0 AV			1.92 V	86	101.8	4.2
4	#5987.48	60.4 PK	68.2	-7.8	1.93 V	80	55.9	4.5
5	11490.00	67.5 PK	74.0	-6.5	1.42 V	24	52.3	15.2
6	11490.00	53.4 AV	54.0	-0.6	1.42 V	24	38.2	15.2
7	#17235.00	60.9 PK	74.0	-13.1	2.88 V	48	40.9	20.0
8	#17235.00	48.6 AV	54.0	-5.4	2.88 V	48	28.6	20.0

REMARKS:

1. Emission Level(dBuV/m) = Raw Value(dBuV) + Correction Factor(dB/m)
2. Correction Factor(dB/m) = Antenna Factor(dB/m) + Cable Factor(dB) – Pre-Amplifier Factor(dB)
3. The other emission levels were very low against the limit.
4. Margin value = Emission Level – Limit value
5. " * ": Fundamental frequency.
6. " # ": The radiated frequency is out of the restricted band.

CHANNEL	TX Channel 157	DETECTOR FUNCTION	Peak (PK)
FREQUENCY RANGE	1GHz ~ 40GHz		Average (AV)

ANTENNA POLARITY & TEST DISTANCE: HORIZONTAL AT 3 M

NO.	FREQ. (MHz)	EMISSION LEVEL (dBuV/m)	LIMIT (dBuV/m)	MARGIN (dB)	ANTENNA HEIGHT (m)	TABLE ANGLE (Degree)	RAW VALUE (dBuV)	CORRECTION FACTOR (dB/m)
1	#5626.00	56.8 PK	68.2	-11.4	1.83 H	158	52.8	4.0
2	*5785.00	115.3 PK			1.83 H	158	111.2	4.1
3	*5785.00	105.8 AV			1.83 H	158	101.7	4.1
4	#5926.68	57.4 PK	68.2	-10.8	1.83 H	158	53.0	4.4
5	11570.00	67.4 PK	74.0	-6.6	1.46 H	7	52.3	15.1
6	11570.00	53.1 AV	54.0	-0.9	1.46 H	7	38.0	15.1
7	#17355.00	63.7 PK	74.0	-10.3	2.37 H	35	43.2	20.5
8	#17355.00	51.0 AV	54.0	-3.0	2.37 H	35	30.5	20.5

ANTENNA POLARITY & TEST DISTANCE: VERTICAL AT 3 M

NO.	FREQ. (MHz)	EMISSION LEVEL (dBuV/m)	LIMIT (dBuV/m)	MARGIN (dB)	ANTENNA HEIGHT (m)	TABLE ANGLE (Degree)	RAW VALUE (dBuV)	CORRECTION FACTOR (dB/m)
1	#5626.00	56.3 PK	68.2	-11.9	1.93 V	80	52.3	4.0
2	*5785.00	115.6 PK			1.93 V	80	111.5	4.1
3	*5785.00	105.3 AV			1.93 V	80	101.2	4.1
4	#5937.12	58.9 PK	68.2	-9.3	1.93 V	80	54.5	4.4
5	11570.00	67.1 PK	74.0	-6.9	1.39 V	30	52.0	15.1
6	11570.00	53.0 AV	54.0	-1.0	1.39 V	30	37.9	15.1
7	#17355.00	60.3 PK	74.0	-13.7	2.93 V	33	39.8	20.5
8	#17355.00	48.1 AV	54.0	-5.9	2.93 V	33	27.6	20.5

REMARKS:

1. Emission Level(dBuV/m) = Raw Value(dBuV) + Correction Factor(dB/m)
2. Correction Factor(dB/m) = Antenna Factor(dB/m) + Cable Factor(dB) – Pre-Amplifier Factor(dB)
3. The other emission levels were very low against the limit.
4. Margin value = Emission Level – Limit value
5. " * ": Fundamental frequency.
6. " # ": The radiated frequency is out of the restricted band.

CHANNEL	TX Channel 165	DETECTOR FUNCTION	Peak (PK)
FREQUENCY RANGE	1GHz ~ 40GHz		Average (AV)

ANTENNA POLARITY & TEST DISTANCE: HORIZONTAL AT 3 M

NO.	FREQ. (MHz)	EMISSION LEVEL (dBuV/m)	LIMIT (dBuV/m)	MARGIN (dB)	ANTENNA HEIGHT (m)	TABLE ANGLE (Degree)	RAW VALUE (dBuV)	CORRECTION FACTOR (dB/m)
1	#5605.57	56.9 PK	68.2	-11.3	1.81 H	177	53.0	3.9
2	*5825.00	115.5 PK			1.84 H	164	111.3	4.2
3	*5825.00	106.0 AV			1.84 H	164	101.8	4.2
4	#5955.65	56.2 PK	68.2	-12.0	1.81 H	177	51.8	4.4
5	11650.00	68.1 PK	74.0	-5.9	1.37 H	2	53.1	15.0
6	11650.00	53.8 AV	54.0	-0.2	1.37 H	2	38.8	15.0
7	#17475.00	67.1 PK	74.0	-6.9	1.58 H	41	46.0	21.1
8	#17475.00	53.2 AV	54.0	-0.8	1.58 H	41	32.1	21.1

ANTENNA POLARITY & TEST DISTANCE: VERTICAL AT 3 M

NO.	FREQ. (MHz)	EMISSION LEVEL (dBuV/m)	LIMIT (dBuV/m)	MARGIN (dB)	ANTENNA HEIGHT (m)	TABLE ANGLE (Degree)	RAW VALUE (dBuV)	CORRECTION FACTOR (dB/m)
1	#5640.73	56.8 PK	68.2	-11.4	1.92 V	86	52.8	4.0
2	*5825.00	115.3 PK			1.93 V	76	111.1	4.2
3	*5825.00	105.5 AV			1.93 V	76	101.3	4.2
4	#5984.62	58.6 PK	68.2	-9.6	1.92 V	86	54.1	4.5
5	11650.00	67.4 PK	74.0	-6.6	1.73 V	3	52.4	15.0
6	11650.00	53.5 AV	54.0	-0.5	1.73 V	3	38.5	15.0
7	#17475.00	61.8 PK	74.0	-12.2	2.92 V	40	40.7	21.1
8	#17475.00	49.5 AV	54.0	-4.5	2.92 V	40	28.4	21.1

REMARKS:

1. Emission Level(dBuV/m) = Raw Value(dBuV) + Correction Factor(dB/m)
2. Correction Factor(dB/m) = Antenna Factor(dB/m) + Cable Factor(dB) – Pre-Amplifier Factor(dB)
3. The other emission levels were very low against the limit.
4. Margin value = Emission Level – Limit value
5. " * ": Fundamental frequency.
6. " # ": The radiated frequency is out of the restricted band.

802.11ac (VHT40)

CHANNEL	TX Channel 38	DETECTOR FUNCTION	Peak (PK)
FREQUENCY RANGE	1GHz ~ 40GHz		Average (AV)

ANTENNA POLARITY & TEST DISTANCE: HORIZONTAL AT 3 M

NO.	FREQ. (MHz)	EMISSION LEVEL (dBuV/m)	LIMIT (dBuV/m)	MARGIN (dB)	ANTENNA HEIGHT (m)	TABLE ANGLE (Degree)	RAW VALUE (dBuV)	CORRECTION FACTOR (dB/m)
1	5150.00	69.0 PK	74.0	-5.0	1.86 H	332	66.0	3.0
2	5150.00	50.5 AV	54.0	-3.5	1.86 H	332	47.5	3.0
3	*5190.00	110.2 PK			1.86 H	332	107.1	3.1
4	*5190.00	101.3 AV			1.86 H	332	98.2	3.1
5	#10380.00	56.5 PK	74.0	-17.5	1.81 H	297	42.8	13.7
6	#10380.00	42.3 AV	54.0	-11.7	1.81 H	297	28.6	13.7
7	15570.00	56.8 PK	74.0	-17.2	2.17 H	55	41.2	15.6
8	15570.00	44.4 AV	54.0	-9.6	2.17 H	55	28.8	15.6

ANTENNA POLARITY & TEST DISTANCE: VERTICAL AT 3 M

NO.	FREQ. (MHz)	EMISSION LEVEL (dBuV/m)	LIMIT (dBuV/m)	MARGIN (dB)	ANTENNA HEIGHT (m)	TABLE ANGLE (Degree)	RAW VALUE (dBuV)	CORRECTION FACTOR (dB/m)
1	5150.00	73.7 PK	74.0	-0.3	1.76 V	86	70.7	3.0
2	5150.00	53.1 AV	54.0	-0.9	1.76 V	86	50.1	3.0
3	*5190.00	111.0 PK			1.76 V	86	107.9	3.1
4	*5190.00	101.5 AV			1.76 V	86	98.4	3.1
5	#10380.00	56.1 PK	74.0	-17.9	1.39 V	50	42.4	13.7
6	#10380.00	41.9 AV	54.0	-12.1	1.39 V	50	28.2	13.7
7	15570.00	56.4 PK	74.0	-17.6	3.03 V	66	40.8	15.6
8	15570.00	44.0 AV	54.0	-10.0	3.03 V	66	28.4	15.6

REMARKS:

- Emission Level(dBuV/m) = Raw Value(dBuV) + Correction Factor(dB/m)
- Correction Factor(dB/m) = Antenna Factor(dB/m) + Cable Factor(dB) – Pre-Amplifier Factor(dB)
- The other emission levels were very low against the limit.
- Margin value = Emission Level – Limit value
- " * ": Fundamental frequency.
- " # ": The radiated frequency is out of the restricted band.

CHANNEL	TX Channel 46	DETECTOR FUNCTION	Peak (PK)
FREQUENCY RANGE	1GHz ~ 40GHz		Average (AV)

ANTENNA POLARITY & TEST DISTANCE: HORIZONTAL AT 3 M

NO.	FREQ. (MHz)	EMISSION LEVEL (dBuV/m)	LIMIT (dBuV/m)	MARGIN (dB)	ANTENNA HEIGHT (m)	TABLE ANGLE (Degree)	RAW VALUE (dBuV)	CORRECTION FACTOR (dB/m)
1	*5230.00	113.2 PK			1.80 H	187	110.0	3.2
2	*5230.00	104.3 AV			1.80 H	187	101.1	3.2
3	5350.00	56.6 PK	74.0	-17.4	1.80 H	187	53.1	3.5
4	5350.00	43.3 AV	54.0	-10.7	1.80 H	187	39.8	3.5
5	#10460.00	58.4 PK	74.0	-15.6	1.92 H	295	44.5	13.9
6	#10460.00	44.8 AV	54.0	-9.2	1.92 H	295	30.9	13.9
7	15690.00	56.3 PK	74.0	-17.7	2.17 H	36	40.7	15.6
8	15690.00	44.5 AV	54.0	-9.5	2.17 H	36	28.9	15.6

ANTENNA POLARITY & TEST DISTANCE: VERTICAL AT 3 M

NO.	FREQ. (MHz)	EMISSION LEVEL (dBuV/m)	LIMIT (dBuV/m)	MARGIN (dB)	ANTENNA HEIGHT (m)	TABLE ANGLE (Degree)	RAW VALUE (dBuV)	CORRECTION FACTOR (dB/m)
1	*5230.00	113.7 PK			1.71 V	93	110.5	3.2
2	*5230.00	104.5 AV			1.71 V	93	101.3	3.2
3	5350.00	56.2 PK	74.0	-17.8	1.71 V	93	52.7	3.5
4	5350.00	43.0 AV	54.0	-11.0	1.71 V	93	39.5	3.5
5	#10460.00	57.5 PK	74.0	-16.5	1.42 V	50	43.6	13.9
6	#10460.00	44.3 AV	54.0	-9.7	1.42 V	50	30.4	13.9
7	15690.00	56.4 PK	74.0	-17.6	3.02 V	72	40.8	15.6
8	15690.00	44.0 AV	54.0	-10.0	3.02 V	72	28.4	15.6

REMARKS:

1. Emission Level(dBuV/m) = Raw Value(dBuV) + Correction Factor(dB/m)
2. Correction Factor(dB/m) = Antenna Factor(dB/m) + Cable Factor(dB) – Pre-Amplifier Factor(dB)
3. The other emission levels were very low against the limit.
4. Margin value = Emission Level – Limit value
5. " * ": Fundamental frequency.
6. " # ": The radiated frequency is out of the restricted band.

CHANNEL	TX Channel 151	DETECTOR FUNCTION	Peak (PK)
FREQUENCY RANGE	1GHz ~ 40GHz		Average (AV)

ANTENNA POLARITY & TEST DISTANCE: HORIZONTAL AT 3 M

NO.	FREQ. (MHz)	EMISSION LEVEL (dBuV/m)	LIMIT (dBuV/m)	MARGIN (dB)	ANTENNA HEIGHT (m)	TABLE ANGLE (Degree)	RAW VALUE (dBuV)	CORRECTION FACTOR (dB/m)
1	#5627.90	57.5 PK	68.2	-10.7	1.73 H	177	53.5	4.0
2	*5755.00	113.6 PK			1.74 H	181	109.4	4.2
3	*5755.00	104.3 AV			1.74 H	181	100.1	4.2
4	#5949.00	57.3 PK	68.2	-10.9	1.73 H	177	52.9	4.4
5	11510.00	67.6 PK	74.0	-6.4	1.81 H	289	52.5	15.1
6	11510.00	53.3 AV	54.0	-0.7	1.81 H	289	38.2	15.1
7	#17265.00	59.2 PK	74.0	-14.8	2.20 H	37	39.3	19.9
8	#17265.00	48.2 AV	54.0	-5.8	2.20 H	37	28.3	19.9

ANTENNA POLARITY & TEST DISTANCE: VERTICAL AT 3 M

NO.	FREQ. (MHz)	EMISSION LEVEL (dBuV/m)	LIMIT (dBuV/m)	MARGIN (dB)	ANTENNA HEIGHT (m)	TABLE ANGLE (Degree)	RAW VALUE (dBuV)	CORRECTION FACTOR (dB/m)
1	#5644.52	57.0 PK	68.2	-11.2	1.86 V	151	53.0	4.0
2	*5755.00	114.4 PK			1.95 V	175	110.2	4.2
3	*5755.00	104.0 AV			1.95 V	175	99.8	4.2
4	#5994.12	58.3 PK	68.2	-9.9	1.86 V	151	53.8	4.5
5	11510.00	67.8 PK	74.0	-6.2	1.33 V	58	52.7	15.1
6	11510.00	53.1 AV	54.0	-0.9	1.33 V	58	38.0	15.1
7	#17265.00	58.7 PK	74.0	-15.3	2.98 V	74	38.8	19.9
8	#17265.00	47.6 AV	54.0	-6.4	2.98 V	74	27.7	19.9

REMARKS:

1. Emission Level(dBuV/m) = Raw Value(dBuV) + Correction Factor(dB/m)
2. Correction Factor(dB/m) = Antenna Factor(dB/m) + Cable Factor(dB) – Pre-Amplifier Factor(dB)
3. The other emission levels were very low against the limit.
4. Margin value = Emission Level – Limit value
5. " * ": Fundamental frequency.
6. " # ": The radiated frequency is out of the restricted band.

CHANNEL	TX Channel 159	DETECTOR FUNCTION	Peak (PK)
FREQUENCY RANGE	1GHz ~ 40GHz		Average (AV)

ANTENNA POLARITY & TEST DISTANCE: HORIZONTAL AT 3 M

NO.	FREQ. (MHz)	EMISSION LEVEL (dBuV/m)	LIMIT (dBuV/m)	MARGIN (dB)	ANTENNA HEIGHT (m)	TABLE ANGLE (Degree)	RAW VALUE (dBuV)	CORRECTION FACTOR (dB/m)
1	#5631.23	57.7 PK	68.2	-10.5	1.74 H	181	53.7	4.0
2	*5795.00	113.7 PK			1.73 H	177	109.6	4.1
3	*5795.00	104.0 AV			1.73 H	177	99.9	4.1
4	#6000.30	57.6 PK	68.2	-10.6	1.74 H	181	53.1	4.5
5	11590.00	67.5 PK	74.0	-6.5	1.84 H	294	52.4	15.1
6	11590.00	53.0 AV	54.0	-1.0	1.84 H	294	37.9	15.1
7	#17385.00	59.4 PK	74.0	-14.6	2.18 H	24	38.8	20.6
8	#17385.00	48.3 AV	54.0	-5.7	2.18 H	24	27.7	20.6

ANTENNA POLARITY & TEST DISTANCE: VERTICAL AT 3 M

NO.	FREQ. (MHz)	EMISSION LEVEL (dBuV/m)	LIMIT (dBuV/m)	MARGIN (dB)	ANTENNA HEIGHT (m)	TABLE ANGLE (Degree)	RAW VALUE (dBuV)	CORRECTION FACTOR (dB/m)
1	#5638.82	56.3 PK	68.2	-11.9	1.95 V	175	52.3	4.0
2	*5795.00	112.8 PK			1.86 V	151	108.7	4.1
3	*5795.00	103.3 AV			1.86 V	151	99.2	4.1
4	#5996.98	57.7 PK	68.2	-10.5	1.95 V	175	53.2	4.5
5	11590.00	68.4 PK	74.0	-5.6	1.37 V	40	53.3	15.1
6	11590.00	53.5 AV	54.0	-0.5	1.37 V	40	38.4	15.1
7	#17385.00	58.7 PK	74.0	-15.3	2.97 V	70	38.1	20.6
8	#17385.00	47.7 AV	54.0	-6.3	2.97 V	70	27.1	20.6

REMARKS:

1. Emission Level(dBuV/m) = Raw Value(dBuV) + Correction Factor(dB/m)
2. Correction Factor(dB/m) = Antenna Factor(dB/m) + Cable Factor(dB) – Pre-Amplifier Factor(dB)
3. The other emission levels were very low against the limit.
4. Margin value = Emission Level – Limit value
5. " * ": Fundamental frequency.
6. " # ": The radiated frequency is out of the restricted band.

802.11ac (VHT80)

CHANNEL	TX Channel 42	DETECTOR FUNCTION	Peak (PK)
FREQUENCY RANGE	1GHz ~ 40GHz		Average (AV)

ANTENNA POLARITY & TEST DISTANCE: HORIZONTAL AT 3 M

NO.	FREQ. (MHz)	EMISSION LEVEL (dBuV/m)	LIMIT (dBuV/m)	MARGIN (dB)	ANTENNA HEIGHT (m)	TABLE ANGLE (Degree)	RAW VALUE (dBuV)	CORRECTION FACTOR (dB/m)
1	5150.00	68.9 PK	74.0	-5.1	1.82 H	181	65.9	3.0
2	5150.00	50.1 AV	54.0	-3.9	1.82 H	181	47.1	3.0
3	*5210.00	108.6 PK			1.82 H	181	105.4	3.2
4	*5210.00	97.9 AV			1.82 H	181	94.7	3.2
5	5350.00	55.9 PK	74.0	-18.1	1.82 H	181	52.4	3.5
6	5350.00	40.1 AV	54.0	-13.9	1.82 H	181	36.6	3.5
7	#10420.00	54.2 PK	74.0	-19.8	1.85 H	284	40.4	13.8
8	#10420.00	41.5 AV	54.0	-12.5	1.85 H	284	27.7	13.8
9	15630.00	52.9 PK	74.0	-21.1	2.15 H	45	37.2	15.7
10	15630.00	39.6 AV	54.0	-14.4	2.15 H	45	23.9	15.7

ANTENNA POLARITY & TEST DISTANCE: VERTICAL AT 3 M

NO.	FREQ. (MHz)	EMISSION LEVEL (dBuV/m)	LIMIT (dBuV/m)	MARGIN (dB)	ANTENNA HEIGHT (m)	TABLE ANGLE (Degree)	RAW VALUE (dBuV)	CORRECTION FACTOR (dB/m)
1	5150.00	72.5 PK	74.0	-1.5	1.83 V	90	69.5	3.0
2	5150.00	53.9 AV	54.0	-0.1	1.83 V	90	50.9	3.0
3	*5210.00	109.1 PK			1.83 V	90	105.9	3.2
4	*5210.00	98.2 AV			1.83 V	90	95.0	3.2
5	5350.00	56.1 PK	74.0	-17.9	1.83 V	90	52.6	3.5
6	5350.00	42.8 AV	54.0	-11.2	1.83 V	90	39.3	3.5
7	#10420.00	53.8 PK	74.0	-20.2	1.38 V	47	40.0	13.8
8	#10420.00	41.5 AV	54.0	-12.5	1.38 V	47	27.7	13.8
9	15630.00	53.2 PK	74.0	-20.8	3.09 V	76	37.5	15.7
10	15630.00	39.8 AV	54.0	-14.2	3.09 V	76	24.1	15.7

REMARKS:

1. Emission Level(dBuV/m) = Raw Value(dBuV) + Correction Factor(dB/m)
2. Correction Factor(dB/m) = Antenna Factor(dB/m) + Cable Factor(dB) – Pre-Amplifier Factor(dB)
3. The other emission levels were very low against the limit.
4. Margin value = Emission Level – Limit value
5. " * ": Fundamental frequency.
6. " # ": The radiated frequency is out of the restricted band.

CHANNEL	TX Channel 155	DETECTOR FUNCTION	Peak (PK)
FREQUENCY RANGE	1GHz ~ 40GHz		Average (AV)

ANTENNA POLARITY & TEST DISTANCE: HORIZONTAL AT 3 M

NO.	FREQ. (MHz)	EMISSION LEVEL (dBuV/m)	LIMIT (dBuV/m)	MARGIN (dB)	ANTENNA HEIGHT (m)	TABLE ANGLE (Degree)	RAW VALUE (dBuV)	CORRECTION FACTOR (dB/m)
1	#5637.87	63.2 PK	68.2	-5.0	1.80 H	167	59.2	4.0
2	*5775.00	111.7 PK			1.80 H	167	107.5	4.2
3	*5775.00	100.7 AV			1.80 H	167	96.5	4.2
4	#5950.43	58.0 PK	68.2	-10.2	1.80 H	167	53.6	4.4
5	11550.00	64.8 PK	74.0	-9.2	1.83 H	298	49.6	15.2
6	11550.00	51.4 AV	54.0	-2.6	1.83 H	298	36.2	15.2
7	#17325.00	57.1 PK	74.0	-16.9	2.20 H	31	36.8	20.3
8	#17325.00	46.1 AV	54.0	-7.9	2.20 H	31	25.8	20.3

ANTENNA POLARITY & TEST DISTANCE: VERTICAL AT 3 M

NO.	FREQ. (MHz)	EMISSION LEVEL (dBuV/m)	LIMIT (dBuV/m)	MARGIN (dB)	ANTENNA HEIGHT (m)	TABLE ANGLE (Degree)	RAW VALUE (dBuV)	CORRECTION FACTOR (dB/m)
1	#5649.75	62.2 PK	68.2	-6.0	1.96 V	173	58.2	4.0
2	*5775.00	109.2 PK			1.96 V	173	105.0	4.2
3	*5775.00	99.9 AV			1.96 V	173	95.7	4.2
4	#5991.27	56.9 PK	68.2	-11.3	1.96 V	173	52.4	4.5
5	11550.00	64.3 PK	74.0	-9.7	1.42 V	63	49.1	15.2
6	11550.00	51.2 AV	54.0	-2.8	1.42 V	63	36.0	15.2
7	#17325.00	56.6 PK	74.0	-17.4	3.08 V	74	36.3	20.3
8	#17325.00	45.8 AV	54.0	-8.2	3.08 V	74	25.5	20.3

REMARKS:

1. Emission Level(dBuV/m) = Raw Value(dBuV) + Correction Factor(dB/m)
2. Correction Factor(dB/m) = Antenna Factor(dB/m) + Cable Factor(dB) – Pre-Amplifier Factor(dB)
3. The other emission levels were very low against the limit.
4. Margin value = Emission Level – Limit value
5. " * ": Fundamental frequency.
6. " # ": The radiated frequency is out of the restricted band.

Below 1GHz Data:

802.11ac (VHT40)

CHANNEL	TX Channel 151	DETECTOR FUNCTION	Quasi-Peak (QP)
FREQUENCY RANGE	below 1GHz		

ANTENNA POLARITY & TEST DISTANCE: HORIZONTAL AT 3 M

NO.	FREQ. (MHz)	EMISSION LEVEL (dBuV/m)	LIMIT (dBuV/m)	MARGIN (dB)	ANTENNA HEIGHT (m)	TABLE ANGLE (Degree)	RAW VALUE (dBuV)	CORRECTION FACTOR (dB/m)
1	136.63	32.8 QP	43.5	-10.7	1.70 H	293	42.2	-9.4
2	375.00	30.4 QP	46.0	-15.6	1.70 H	48	35.9	-5.5
3	479.98	34.5 QP	46.0	-11.5	1.70 H	194	37.4	-2.9
4	520.02	30.7 QP	46.0	-15.3	1.70 H	13	32.6	-1.9
5	625.02	34.3 QP	46.0	-11.7	1.70 H	333	33.9	0.4
6	874.99	36.7 QP	46.0	-9.3	1.70 H	334	33.0	3.7

ANTENNA POLARITY & TEST DISTANCE: VERTICAL AT 3 M

NO.	FREQ. (MHz)	EMISSION LEVEL (dBuV/m)	LIMIT (dBuV/m)	MARGIN (dB)	ANTENNA HEIGHT (m)	TABLE ANGLE (Degree)	RAW VALUE (dBuV)	CORRECTION FACTOR (dB/m)
1	35.92	35.6 QP	40.0	-4.4	1.70 V	288	45.3	-9.7
2	69.94	28.9 QP	40.0	-11.1	1.70 V	80	39.0	-10.1
3	143.34	28.9 QP	43.5	-14.6	1.70 V	360	37.6	-8.7
4	375.00	33.2 QP	46.0	-12.8	1.70 V	102	38.7	-5.5
5	625.00	36.9 QP	46.0	-9.1	1.70 V	3	36.5	0.4
6	874.99	35.4 QP	46.0	-10.6	1.70 V	356	31.7	3.7

REMARKS:

1. Emission Level(dBuV/m) = Raw Value(dBuV) + Correction Factor(dB/m)
2. Correction Factor(dB/m) = Antenna Factor(dB/m) + Cable Factor(dB) – Pre-Amplifier Factor(dB)
3. The other emission levels were very low against the limit.
4. Margin value = Emission Level – Limit value

4.2 Conducted Emission Measurement

4.2.1 Limits of Conducted Emission Measurement

Frequency (MHz)	Conducted Limit (dBuV)	
	Quasi-peak	Average
0.15 - 0.5	66 - 56	56 - 46
0.50 - 5.0	56	46
5.0 - 30.0	60	50

Note: 1. The lower limit shall apply at the transition frequencies.

2. The limit decreases in line with the logarithm of the frequency in the range of 0.15 to 0.50MHz.

4.2.2 Test Instruments

DESCRIPTION & MANUFACTURER	MODEL NO.	SERIAL NO.	CALIBRATED DATE	CALIBRATED UNTIL
Test Receiver R&S	ESCS 30	847124/029	Oct. 23, 2015	Oct. 22, 2016
Line-Impedance Stabilization Network (for EUT) R&S	ESH3-Z5	848773/004	Oct. 28, 2015	Oct. 27, 2016
RF Cable	5D-FB	COACAB-002	Mar. 04, 2016	Mar. 03, 2017
10 dB PAD Mini-Circuits	HAT-10+	CONATT-004	June 20, 2016	June 19, 2017
Software BVADT	BVADT_Cond_ V7.3.7.3	NA	NA	NA

Note:

1. The calibration interval of the above test instruments are 12 months and the calibrations are traceable to NML/ROC and NIST/USA.
2. The test was performed in Shielded Room No. 1.
3. Tested Date: July 20, 2016

4.2.3 Test Procedure

- The EUT was placed 0.4 meters from the conducting wall of the shielded room with EUT being connected to the power mains through a line impedance stabilization network (LISN). Other support units were connected to the power mains through another LISN. The two LISNs provide 50 ohm/ 50uH of coupling impedance for the measuring instrument.
- Both lines of the power mains connected to the EUT were checked for maximum conducted interference.
- The frequency range from 150kHz to 30MHz was searched. Emission levels under (Limit - 20dB) was not recorded.

NOTE: All modes of operation were investigated and the worst-case emissions are reported.

4.2.4 Deviation from Test Standard

No deviation.

4.2.5 Test Setup

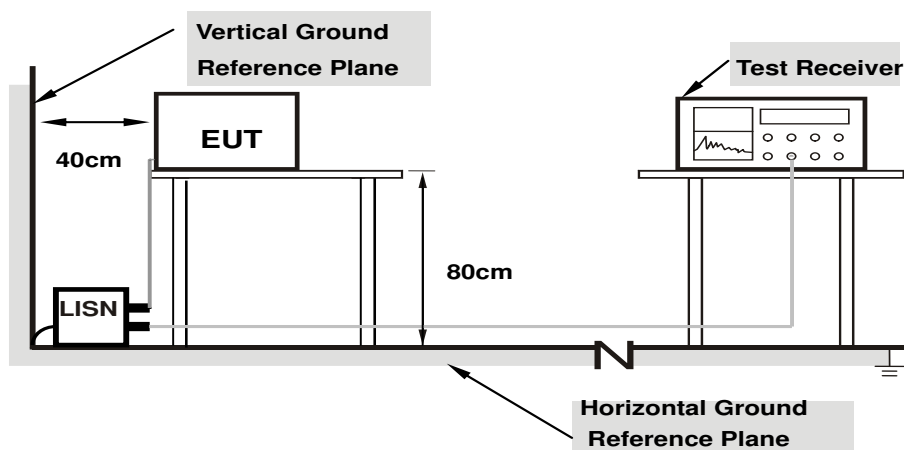

Note: 1.Support units were connected to second LISN.

For the actual test configuration, please refer to the attached file (Test Setup Photo).

4.2.6 EUT Operating Condition

Same as 4.1.6.

4.2.7 Test Results

Phase	Line (L)	Detector Function	Quasi-Peak (QP) / Average (AV)
-------	----------	-------------------	--------------------------------

No	Freq. [MHz]	Corr.	Reading Value		Emission Level		Limit		Margin	
		Factor (dB)	[dB (uV)]		[dB (uV)]		[dB (uV)]		(dB)	
			Q.P.	AV.	Q.P.	AV.	Q.P.	AV.	Q.P.	AV.
1	0.16562	10.21	38.52	28.02	48.73	38.23	65.18	55.18	-16.44	-16.94
2	0.19297	10.22	33.69	23.06	43.91	33.28	63.91	53.91	-20.00	-20.63
3	0.24766	10.22	34.09	29.29	44.31	39.51	61.84	51.84	-17.53	-12.33
4	0.30234	10.22	23.52	14.09	33.74	24.31	60.18	50.18	-26.44	-25.87
5	0.89609	10.25	18.87	14.62	29.12	24.87	56.00	46.00	-26.88	-21.13
6	24.00000	11.43	28.97	28.33	40.40	39.76	60.00	50.00	-19.60	-10.24

REMARKS:

1. Q.P. and AV. are abbreviations of quasi-peak and average individually.
2. The emission levels of other frequencies were very low against the limit.
3. Margin value = Emission level - Limit value
4. Correction factor = Insertion loss + Cable loss
5. Emission Level = Correction Factor + Reading Value.

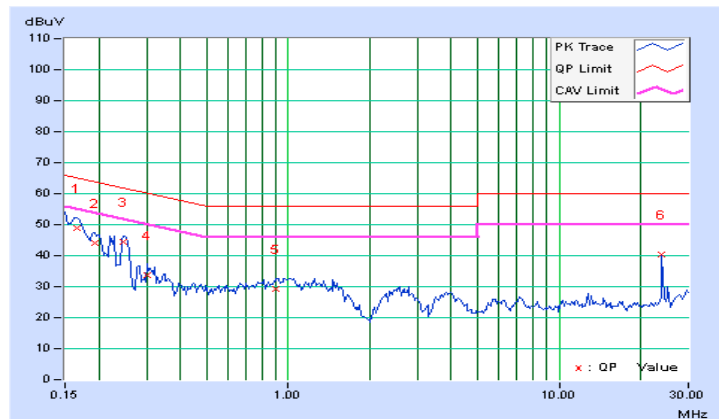

Phase	Neutral (N)	Detector Function	Quasi-Peak (QP) / Average (AV)
-------	-------------	-------------------	--------------------------------

No	Freq. [MHz]	Corr. Factor	Reading Value [dB (uV)]		Emission Level [dB (uV)]		Limit [dB (uV)]		Margin (dB)	
		(dB)	Q.P.	AV.	Q.P.	AV.	Q.P.	AV.	Q.P.	AV.
	1	0.16562	10.20	38.58	28.48	48.78	38.68	65.18	55.18	-16.40
2	0.19297	10.21	33.34	23.47	43.55	33.68	63.91	53.91	-20.36	-20.23
3	0.24766	10.21	34.21	30.16	44.42	40.37	61.84	51.84	-17.42	-11.47
4	0.96641	10.24	20.22	14.05	30.46	24.29	56.00	46.00	-25.54	-21.71
5	1.41797	10.26	20.11	15.15	30.37	25.41	56.00	46.00	-25.63	-20.59
6	24.00000	11.13	28.33	28.33	39.46	39.46	60.00	50.00	-20.54	-10.54

REMARKS:

1. Q.P. and AV. are abbreviations of quasi-peak and average individually.
2. The emission levels of other frequencies were very low against the limit.
3. Margin value = Emission level - Limit value
4. Correction factor = Insertion loss + Cable loss
5. Emission Level = Correction Factor + Reading Value.

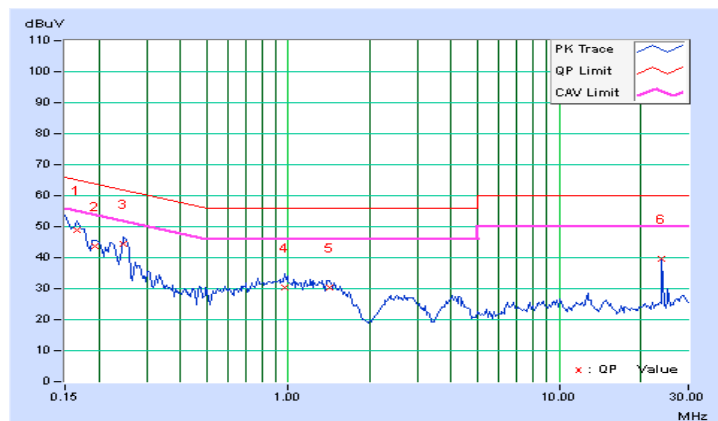

4.3 Transmit Power Measurement

4.3.1 Limits of Transmit Power Measurement

Operation Band	EUT Category		Limit
U-NII-1		Outdoor Access Point	1 Watt (30 dBm) (Max. e.i.r.p \leq 125mW(21 dBm) at any elevation angle above 30 degrees as measured from the horizon)
		Fixed point-to-point Access Point	1 Watt (30 dBm)
	√	Indoor Access Point	1 Watt (30 dBm)
		Mobile and Portable client device	250mW (24 dBm)
U-NII-2A			250mW (24 dBm) or 11 dBm+10 log B*
U-NII-2C			250mW (24 dBm) or 11 dBm+10 log B*
U-NII-3		√	1 Watt (30 dBm)

*B is the 26 dB emission bandwidth in megahertz

Per KDB 662911 Method of conducted output power measurement on IEEE 802.11 devices,

Array Gain = 0 dB (i.e., no array gain) for $N_{ANT} \leq 4$;

Array Gain = 0 dB (i.e., no array gain) for channel widths ≥ 40 MHz for any N_{ANT} ;

Array Gain = $5 \log(N_{ANT}/N_{SS})$ dB or 3 dB, whichever is less for 20-MHz channel widths with $N_{ANT} \geq 5$.

For power measurements on all other devices: Array Gain = $10 \log(N_{ANT}/N_{SS})$ dB.

4.3.2 Test Setup

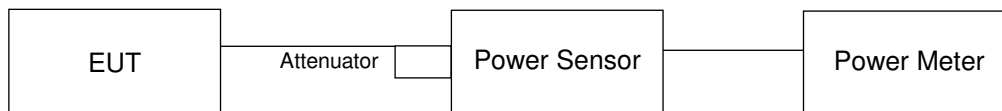

4.3.3 Test Instruments

Refer to section 4.1.2 to get information of above instrument.

4.3.4 Test Procedure

Method PM is used to perform output power measurement, trigger and gating function of wide band power meter is enabled to measure max output power of TX on burst. Duty factor is not added to measured value.

4.3.5 Deviation from Test Standard

No deviation.

4.3.6 EUT Operating Condition

The software provided by client to enable the EUT under transmission condition continuously at lowest, middle and highest channel frequencies individually.

4.3.7 Test Result

CDD Mode
802.11a

Chan.	Chan. Freq. (MHz)	Maximum Conducted Power (dBm)				Total Power (mW)	Total Power (dBm)	Limit (dBm)	Pass / Fail
		Chain 0	Chain 1	Chain 2	Chain 3				
36	5180	18.86	19.14	19.35	19.50	334.172	25.24	30.00	Pass
40	5200	18.83	19.15	19.27	19.56	333.501	25.23	30.00	Pass
48	5240	18.97	19.28	19.34	19.13	331.356	25.20	30.00	Pass
149	5745	18.93	19.27	18.93	18.54	312.304	24.95	30.00	Pass
157	5785	18.70	19.16	18.91	18.76	309.511	24.91	30.00	Pass
165	5825	19.41	19.98	19.75	18.31	349.008	25.43	30.00	Pass

802.11ac (VHT20)

Chan.	Chan. Freq. (MHz)	Maximum Conducted Power (dBm)				Total Power (mW)	Total Power (dBm)	Limit (dBm)	Pass / Fail
		Chain 0	Chain 1	Chain 2	Chain 3				
36	5180	18.77	19.26	19.48	19.42	335.883	25.26	30.00	Pass
40	5200	19.13	19.27	19.41	19.47	342.183	25.34	30.00	Pass
48	5240	18.81	19.13	19.52	19.35	333.514	25.23	30.00	Pass
149	5745	18.77	19.20	19.01	18.78	313.637	24.96	30.00	Pass
157	5785	18.80	19.43	19.03	18.67	317.162	25.01	30.00	Pass
165	5825	19.39	19.89	19.75	19.47	367.313	25.65	30.00	Pass

802.11ac (VHT40)

Chan.	Chan. Freq. (MHz)	Maximum Conducted Power (dBm)				Total Power (mW)	Total Power (dBm)	Limit (dBm)	Pass / Fail
		Chain 0	Chain 1	Chain 2	Chain 3				
38	5190	16.63	17.15	16.72	17.06	195.711	22.92	30.00	Pass
46	5230	19.23	19.33	19.71	19.34	348.899	25.43	30.00	Pass
151	5755	19.82	20.51	20.38	19.83	413.705	26.17	30.00	Pass
159	5795	19.87	20.19	20.31	19.77	403.764	26.06	30.00	Pass

802.11ac (VHT80)

Chan.	Chan. Freq. (MHz)	Maximum Conducted Power (dBm)				Total Power (mW)	Total Power (dBm)	Limit (dBm)	Pass / Fail
		Chain 0	Chain 1	Chain 2	Chain 3				
42	5210	16.62	16.72	16.61	16.45	182.88	22.62	30.00	Pass
155	5775	18.94	19.88	19.84	19.53	361.744	25.58	30.00	Pass

Beamforming Mode

802.11ac (VHT20)

Chan.	Chan. Freq. (MHz)	Maximum Conducted Power (dBm)				Total Power (mW)	Total Power (dBm)	Limit (dBm)	Pass / Fail
		Chain 0	Chain 1	Chain 2	Chain 3				
36	5180	18.77	19.26	19.48	19.42	335.883	25.26	30.00	Pass
40	5200	19.13	19.27	19.41	19.47	342.183	25.34	30.00	Pass
48	5240	18.81	19.13	19.52	19.35	333.514	25.23	30.00	Pass
149	5745	18.77	19.20	19.01	18.78	313.637	24.96	30.00	Pass
157	5785	18.80	19.43	19.03	18.67	317.162	25.01	30.00	Pass
165	5825	19.39	19.89	19.75	19.47	367.313	25.65	30.00	Pass

802.11ac (VHT40)

Chan.	Chan. Freq. (MHz)	Maximum Conducted Power (dBm)				Total Power (mW)	Total Power (dBm)	Limit (dBm)	Pass / Fail
		Chain 0	Chain 1	Chain 2	Chain 3				
38	5190	16.63	17.15	16.72	17.06	195.711	22.92	30.00	Pass
46	5230	19.23	19.33	19.71	19.34	348.899	25.43	30.00	Pass
151	5755	19.82	20.51	20.38	19.83	413.705	26.17	30.00	Pass
159	5795	19.87	20.19	20.31	19.77	403.764	26.06	30.00	Pass

802.11ac (VHT80)

Chan.	Chan. Freq. (MHz)	Maximum Conducted Power (dBm)				Total Power (mW)	Total Power (dBm)	Limit (dBm)	Pass / Fail
		Chain 0	Chain 1	Chain 2	Chain 3				
42	5210	16.62	16.72	16.61	16.45	182.88	22.62	30.00	Pass
155	5775	18.94	19.88	19.84	19.53	361.744	25.58	30.00	Pass

4.4 Occupied Bandwidth Measurement

4.4.1 Test Setup

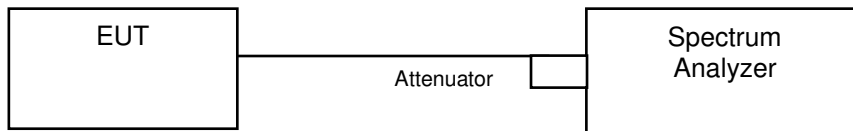

4.4.2 Test Instruments

Refer to section 4.1.2 to get information of above instrument.

4.4.3 Test Procedure

The transmitter output was connected to the spectrum analyzer through an attenuator. The bandwidth of the fundamental frequency was measured by spectrum analyzer with resolution bandwidth in the range of 1% to 5% of the anticipated emission bandwidth, and a video bandwidth at least 3x the resolution bandwidth and set the detector to SAMPLE. The width of a frequency band such that, below the lower and above the upper frequency limits, the mean powers emitted are each equal to a specified percentage 0.5 %of the total mean power of a given emission.

4.4.4 Test Results

802.11a

Channel	Channel Frequency (MHz)	Occupied Bandwidth (MHz)			
		CHAIN 0	CHAIN 1	CHAIN 2	CHAIN 3
36	5180	16.92	16.92	16.92	17.04
40	5200	16.92	16.92	16.80	16.92
48	5240	16.92	16.92	16.92	17.04
149	5745	16.68	17.16	16.80	16.92
157	5785	16.92	17.40	16.92	16.92
165	5825	16.92	17.28	17.04	17.04

802.11ac (VHT20)

Channel	Channel Frequency (MHz)	Occupied Bandwidth (MHz)			
		CHAIN 0	CHAIN 1	CHAIN 2	CHAIN 3
36	5180	18.24	18.24	18.00	18.12
40	5200	18.12	18.12	18.00	18.24
48	5240	18.12	17.88	18.12	18.12
149	5745	18.12	18.48	18.12	18.12
157	5785	18.24	18.48	18.00	18.12
165	5825	18.00	18.12	18.12	18.00

802.11ac (VHT40)

Channel	Channel Frequency (MHz)	Occupied Bandwidth (MHz)			
		CHAIN 0	CHAIN 1	CHAIN 2	CHAIN 3
38	5190	36.72	36.72	36.96	36.72
46	5230	36.96	36.72	36.72	36.72
151	5755	36.96	36.48	36.96	36.96
159	5795	36.72	36.72	36.72	36.96

802.11ac (VHT80)

Channel	Channel Frequency (MHz)	Occupied Bandwidth (MHz)			
		CHAIN 0	CHAIN 1	CHAIN 2	CHAIN 3
42	5210	75.36	75.84	75.36	75.36
155	5775	75.84	75.36	75.36	75.36

Spectrum Plot of Worst Value

802.11a_Chain1 / CH157

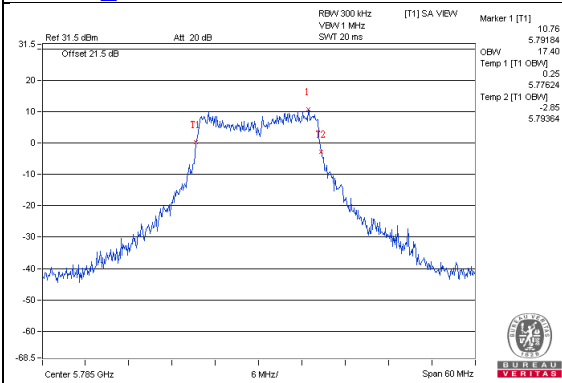

802.11ac (VHT20)_Chain1 / CH149

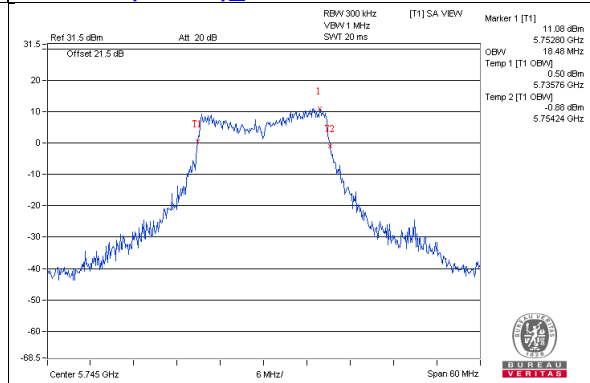

802.11ac (VHT40)_Chain0 / CH46

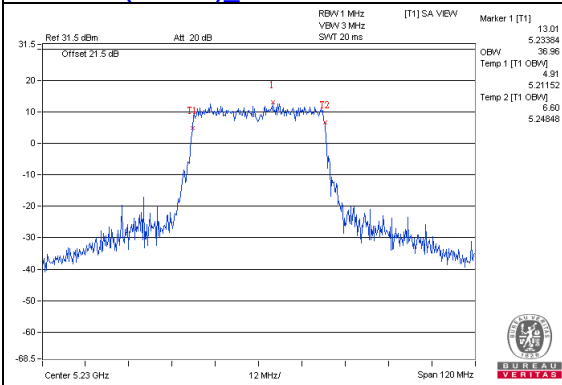

802.11ac (VHT80)_Chain0 / CH155

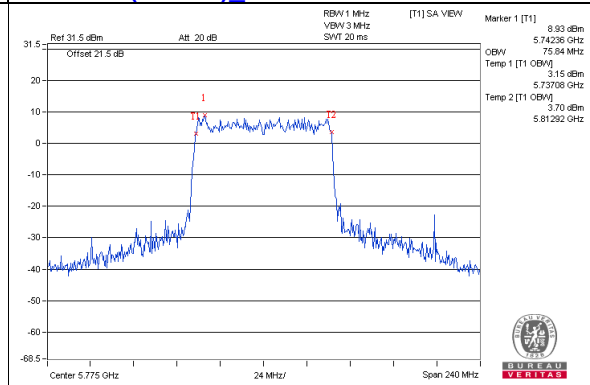

Spectrum Plot for near by DFS band (DFS is required, if 99% OCP straddle into U-NII-2A band)

802.11a_Chain0 / CH48

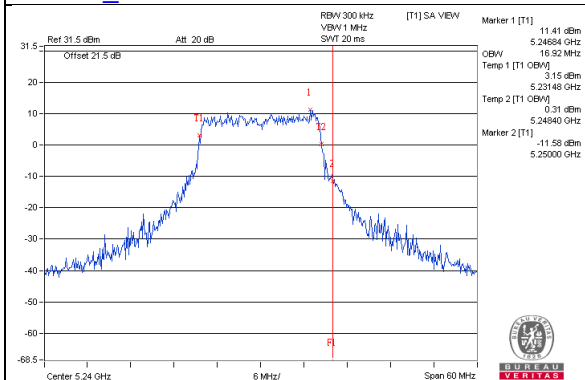

802.11a_Chain1 / CH48

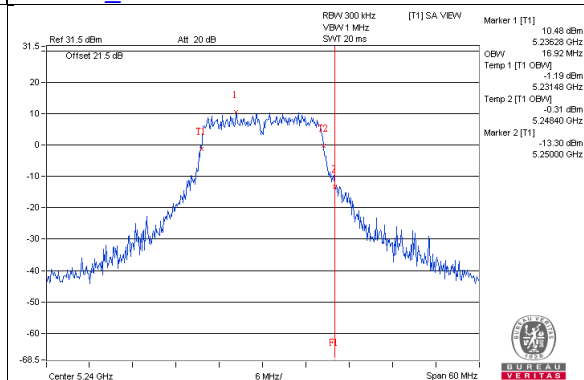

802.11a_Chain2 / CH48

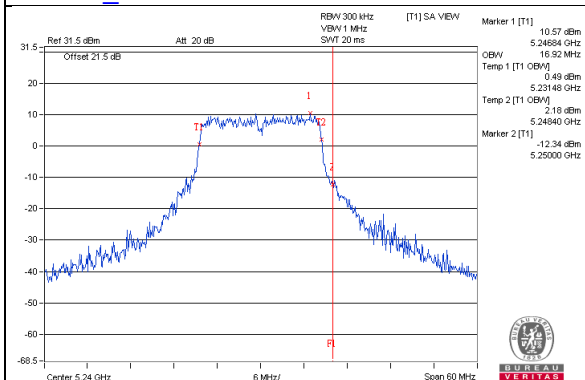

802.11a_Chain3 / CH48

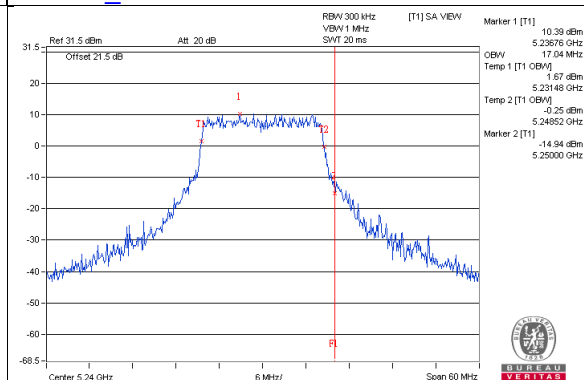

802.11ac(VHT20)_Chain0 / CH48

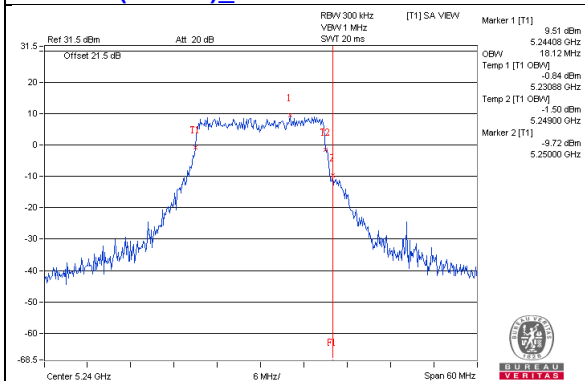

802.11ac(VHT20)_Chain1 / CH48

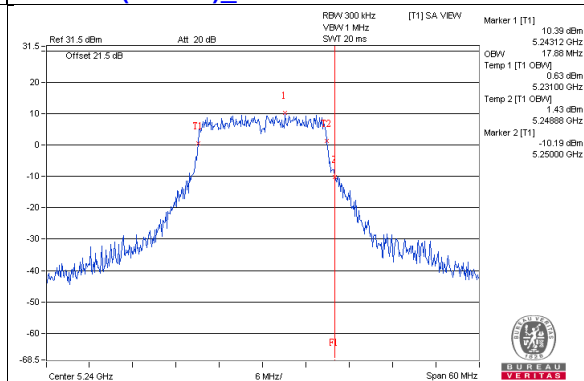

802.11ac(VHT20)_Chain2 / CH48

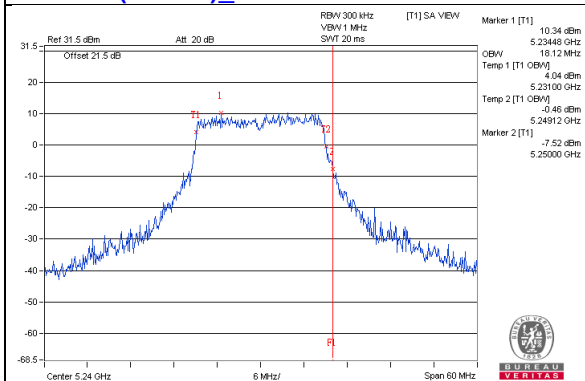

802.11ac(VHT20)_Chain3 / CH48

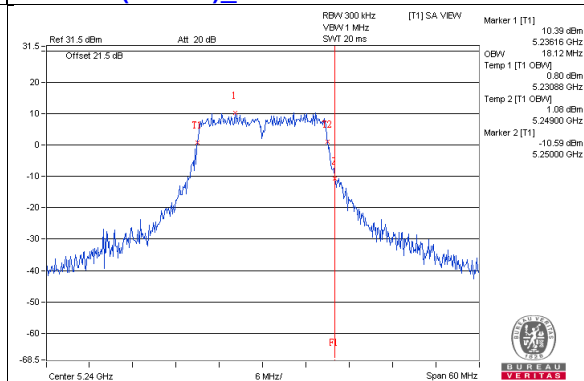

802.11ac(VHT40)_Chain0 / CH46

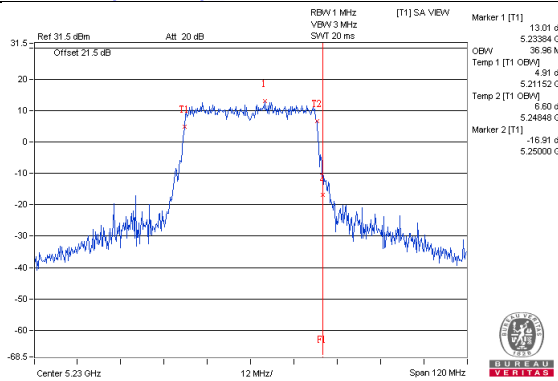

802.11ac(VHT20)_Chain1 / CH46

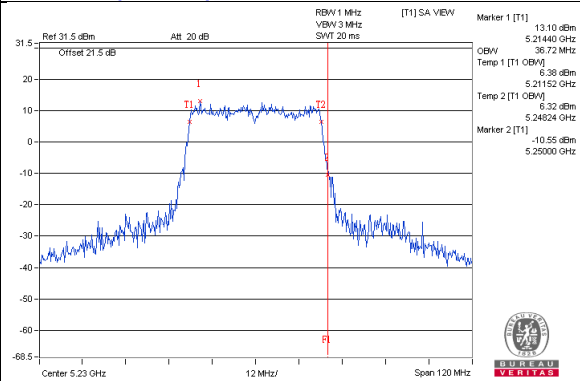

802.11ac(VHT40)_Chain2 / CH46

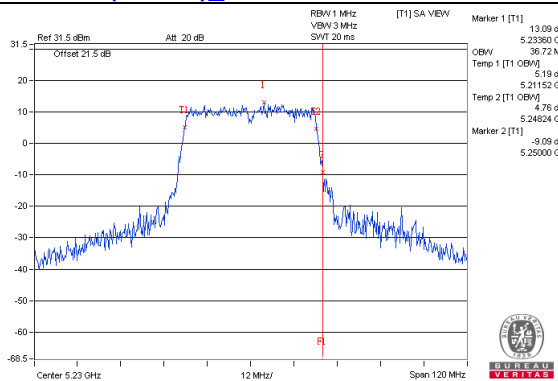

802.11ac(VHT20)_Chain3 / CH46

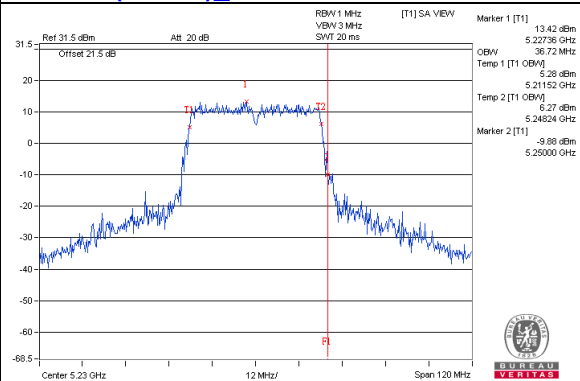

802.11ac(VHT80)_Chain0 / CH42

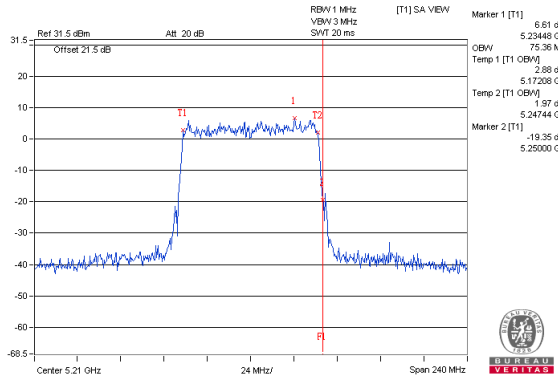

802.11ac(VHT80)_Chain1 / CH42

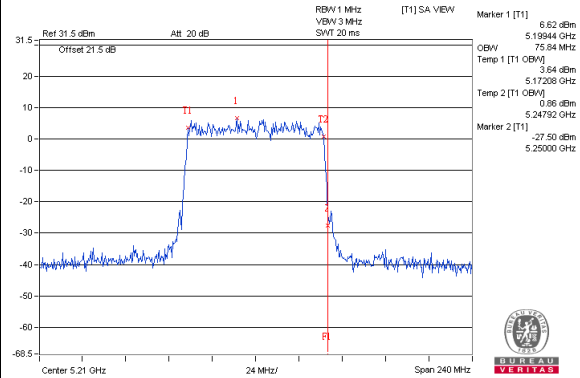

802.11ac(VHT80)_Chain2 / CH42

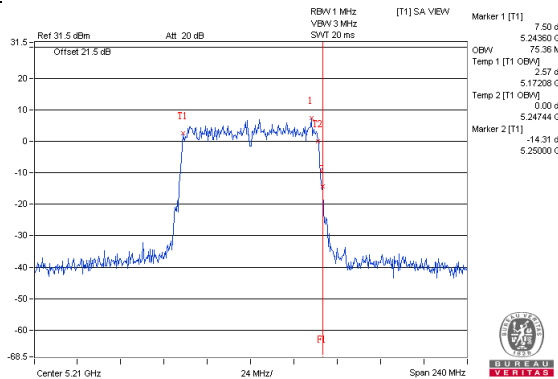

802.11ac(VHT80)_Chain3 / CH42

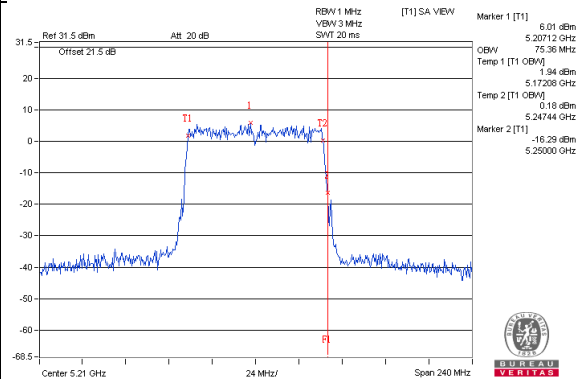

4.5 Peak Power Spectral Density Measurement

4.5.1 Limits of Peak Power Spectral Density Measurement

Operation Band	EUT Category		Limit
U-NII-1		Outdoor Access Point	17dBm/ MHz
		Fixed point-to-point Access Point	
	√	Indoor Access Point	
		Mobile and Portable client device	11dBm/ MHz
U-NII-2A			11dBm/ MHz
U-NII-2C			11dBm/ MHz
U-NII-3		√	30dBm/ 500kHz

4.5.2 Test Setup

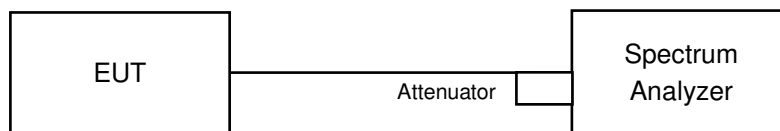

4.5.3 Test Instruments

Refer to section 4.1.2 to get information of above instrument.

4.5.4 Test Procedure

For U-NII-1:

Using method SA-1

1. Set span to encompass the entire emission bandwidth (EBW) of the signal.
2. Set RBW = 1 MHz, Set VBW ≥ 3 MHz, Detector = RMS
3. Sweep time = auto, trigger set to “free run”.
4. Trace average at least 100 traces in power averaging mode.
5. Record the max value

For U-NII-3:

1. Set span to encompass the entire emission bandwidth (EBW) of the signal.
2. Set RBW = 300 kHz, Set VBW ≥ 1 MHz, Detector = RMS
3. Use the peak marker function to determine the maximum power level in any 300 kHz band segment within the fundamental EBW.
4. Scale the observed power level to an equivalent value in 500 kHz by adjusting (reducing) the measured power by a bandwidth correction factor (BWCF) where $BWCF = 10\log(500\text{ kHz}/300\text{ kHz})$
5. Sweep time = auto, trigger set to “free run”.
6. Trace average at least 100 traces in power averaging mode.
7. Record the max value

4.5.5 Deviation from Test Standard

No deviation.

4.5.6 EUT Operating Condition

Same as Item 4.3.6.

4.5.7 Test Results

For U-NII-1:

802.11a

Chan.	Chan. Freq. (MHz)	PSD (dBm/MHz)				Total Power Density (dBm/MHz)	MAX. Limit (dBm/MHz)	Pass / Fail
		Chain 0	Chain 1	Chain 2	Chain 3			
36	5180	5.90	5.45	6.43	5.59	11.88	13.60	Pass
40	5200	6.39	6.10	5.84	5.19	11.92	13.60	Pass
48	5240	6.67	5.26	6.33	6.09	12.14	13.60	Pass

- Note:** 1. Method a) of power density measurement of KDB 662911 is using for calculating total power density. Total power density is summing entire spectra across corresponding frequency bins on the various outputs by computer.
2. Directional gain = $10 \log[(10^{G1/20} + 10^{G2/20} + 10^{G3/20} + 10^{G4/20})^2 / 4] = 9.40\text{dBi} > 6\text{dBi}$, so the power density limit shall be reduced to $17-(9.40-6) = 13.60\text{dBm}$.

802.11ac (VHT20)

Chan.	Chan. Freq. (MHz)	PSD (dBm/MHz)				Total Power Density (dBm/MHz)	MAX. Limit (dBm/MHz)	Pass / Fail
		Chain 0	Chain 1	Chain 2	Chain 3			
36	5180	6.08	5.16	5.35	5.39	11.53	13.60	Pass
40	5200	6.35	5.45	5.68	5.78	11.85	13.60	Pass
48	5240	5.71	5.25	6.08	6.00	11.79	13.60	Pass

- Note:** 1. Method a) of power density measurement of KDB 662911 is using for calculating total power density. Total power density is summing entire spectra across corresponding frequency bins on the various outputs by computer.
2. Directional gain = $10 \log[(10^{G1/20} + 10^{G2/20} + 10^{G3/20} + 10^{G4/20})^2 / 4] = 9.40\text{dBi} > 6\text{dBi}$, so the power density limit shall be reduced to $17-(9.40-6) = 13.60\text{dBm}$.

802.11ac (VHT40)

Chan.	Chan. Freq. (MHz)	PSD (dBm/MHz)				Total Power Density (dBm/MHz)	MAX. Limit (dBm/MHz)	Pass / Fail
		Chain 0	Chain 1	Chain 2	Chain 3			
38	5190	0.27	0.26	0.64	0.58	6.46	13.60	Pass
46	5230	2.76	2.65	3.31	2.78	8.90	13.60	Pass

- Note:** 1. Method a) of power density measurement of KDB 662911 is using for calculating total power density. Total power density is summing entire spectra across corresponding frequency bins on the various outputs by computer.
2. Directional gain = $10 \log[(10^{G1/20} + 10^{G2/20} + 10^{G3/20} + 10^{G4/20})^2 / 4] = 9.40\text{dBi} > 6\text{dBi}$, so the power density limit shall be reduced to $17-(9.40-6) = 13.60\text{dBm}$.

802.11ac (VHT80):

Chan.	Chan. Freq. (MHz)	PSD (dBm/MHz)				Total Power Density (dBm/MHz)	MAX. Limit (dBm/MHz)	Pass / Fail
		Chain 0	Chain 1	Chain 2	Chain 3			
42	5210	-2.37	-3.87	-2.93	-3.37	2.92	13.60	Pass

- Note:** 1. Method a) of power density measurement of KDB 662911 is using for calculating total power density. Total power density is summing entire spectra across corresponding frequency bins on the various outputs by computer.
2. Directional gain = $10 \log[(10^{G1/20} + 10^{G2/20} + 10^{G3/20} + 10^{G4/20})^2 / 4] = 9.40\text{dBi} > 6\text{dBi}$, so the power density limit shall be reduced to $17-(9.40-6) = 13.60\text{dBm}$.

Spectrum Plot of Worst Value

802.11a_Chain 0 / CH48

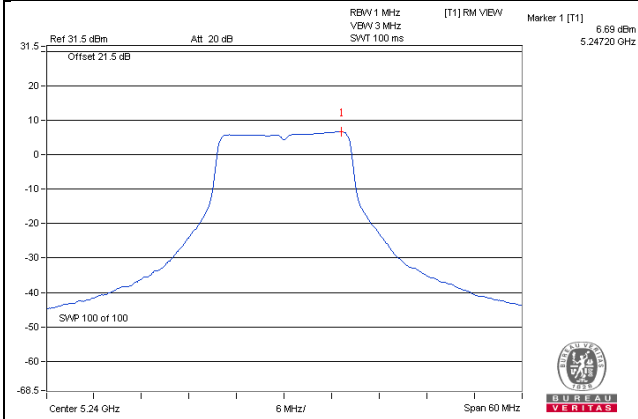

802.11ac (VHT20)_Chain 0 / CH40

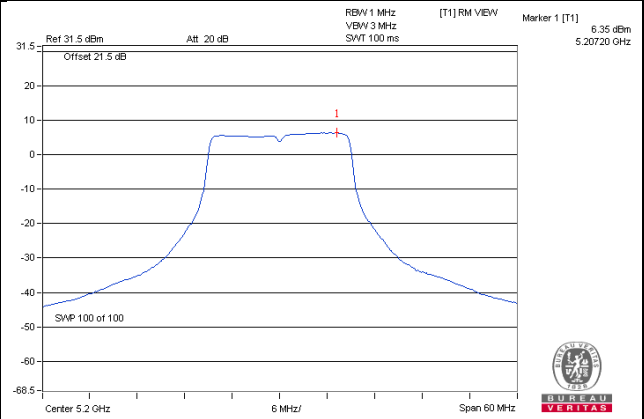

802.11ac (VHT40)_Chain 2 / CH46

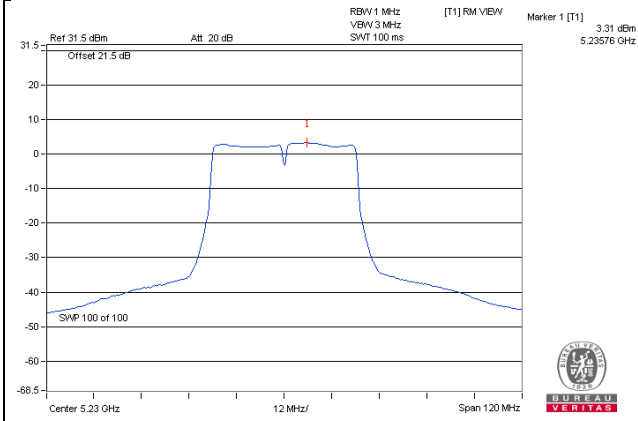

802.11ac (VHT80)_Chain 0 / CH42

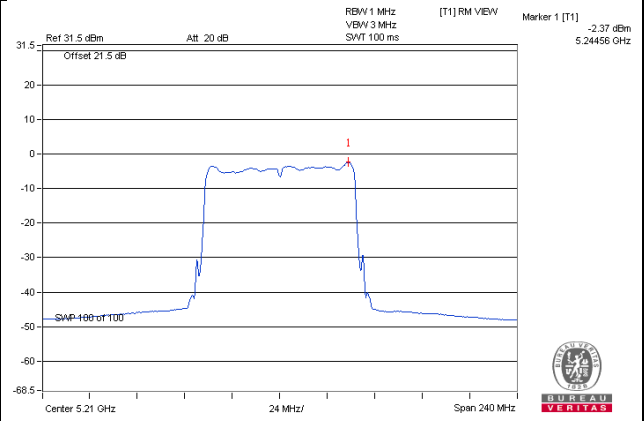

For U-NII-3:
802.11a

TX chain	Channel	Freq. (MHz)	PSD (dBm/300kHz)	PSD (dBm/500kHz)	10 log (N=4) dB	Total PSD (dBm/500kHz)	Limit (dBm/500kHz)	Pass /Fail
0	149	5745	-1.55	0.67	6.02	6.69	26.60	Pass
	157	5785	-1.59	0.63	6.02	6.65	26.60	Pass
	165	5825	-1.84	0.38	6.02	6.40	26.60	Pass
1	149	5745	-0.30	1.92	6.02	7.94	26.60	Pass
	157	5785	-1.06	1.16	6.02	7.18	26.60	Pass
	165	5825	-0.62	1.60	6.02	7.62	26.60	Pass
2	149	5745	-1.88	0.34	6.02	6.36	26.60	Pass
	157	5785	-1.87	0.35	6.02	6.37	26.60	Pass
	165	5825	-1.03	1.19	6.02	7.21	26.60	Pass
3	149	5745	-2.36	-0.14	6.02	5.88	26.60	Pass
	157	5785	-1.80	0.42	6.02	6.44	26.60	Pass
	165	5825	-1.58	0.64	6.02	6.66	26.60	Pass

Note: 1. Directional gain = $10 \log[(10^{G1/20} + 10^{G2/20} + 10^{G3/20} + 10^{G4/20})^2 / 4] = 9.40\text{dBi} > 6\text{dBi}$, so the power density limit shall be reduced to $30 - (9.40 - 6) = 26.60\text{dBm}$.

802.11ac (VHT20)

TX chain	Channel	Freq. (MHz)	PSD (dBm/300kHz)	PSD (dBm/500kHz)	10 log (N=4) dB	Total PSD (dBm/500kHz)	Limit (dBm/500kHz)	Pass /Fail
0	149	5745	-2.47	-0.25	6.02	5.77	26.60	Pass
	157	5785	-2.52	-0.30	6.02	5.72	26.60	Pass
	165	5825	-1.96	0.26	6.02	6.28	26.60	Pass
1	149	5745	-0.50	1.72	6.02	7.74	26.60	Pass
	157	5785	-1.04	1.18	6.02	7.20	26.60	Pass
	165	5825	-1.55	0.67	6.02	6.69	26.60	Pass
2	149	5745	-2.12	0.10	6.02	6.12	26.60	Pass
	157	5785	-2.19	0.03	6.02	6.05	26.60	Pass
	165	5825	-2.36	-0.14	6.02	5.88	26.60	Pass
3	149	5745	-2.62	-0.40	6.02	5.62	26.60	Pass
	157	5785	-2.84	-0.62	6.02	5.40	26.60	Pass
	165	5825	-3.01	-0.79	6.02	5.23	26.60	Pass

Note: 1. Directional gain = $10 \log[(10^{G1/20} + 10^{G2/20} + 10^{G3/20} + 10^{G4/20})^2 / 4] = 9.40\text{dBi} > 6\text{dBi}$, so the power density limit shall be reduced to $30 - (9.40 - 6) = 26.60\text{dBm}$.

802.11ac (VHT40)

TX chain	Channel	Freq. (MHz)	PSD (dBm/300kHz)	PSD (dBm/500kHz)	10 log (N=4) dB	Total PSD (dBm/500kHz)	Limit (dBm/500kHz)	Pass /Fail
0	151	5755	-5.69	-3.47	6.02	2.55	26.60	Pass
	159	5795	-5.94	-3.72	6.02	2.30	26.60	Pass
1	151	5755	-4.27	-2.05	6.02	3.97	26.60	Pass
	159	5795	-4.92	-2.70	6.02	3.32	26.60	Pass
2	151	5755	-5.73	-3.51	6.02	2.51	26.60	Pass
	159	5795	-5.74	-3.52	6.02	2.50	26.60	Pass
3	149	5745	-5.67	-3.45	6.02	2.57	26.60	Pass
	151	5755	-5.99	-3.77	6.02	2.25	26.60	Pass

Note: 1. Directional gain = $10 \log[(10^{G1/20} + 10^{G2/20} + 10^{G3/20} + 10^{G4/20})^2 / 4] = 9.40\text{dBi} > 6\text{dBi}$, so the power density limit shall be reduced to $30 - (9.40 - 6) = 26.60\text{dBm}$.

802.11ac (VHT80)

TX chain	Channel	Freq. (MHz)	PSD (dBm/300kHz)	PSD (dBm/500kHz)	10 log (N=4) dB	Total PSD (dBm/500kHz)	Limit (dBm/500kHz)	Pass /Fail
0	155	5775	-8.40	-6.18	6.02	-0.16	26.60	Pass
1	155	5775	-7.31	-5.09	6.02	0.93	26.60	Pass
2	155	5775	-8.86	-6.64	6.02	-0.62	26.60	Pass
3	155	5775	-8.55	-6.33	6.02	-0.31	26.60	Pass

Note: 1. Directional gain = $10 \log[(10^{G1/20} + 10^{G2/20} + 10^{G3/20} + 10^{G4/20})^2 / 4] = 9.40\text{dBi} > 6\text{dBi}$, so the power density limit shall be reduced to $30 - (9.40 - 6) = 26.60\text{dBm}$.

Spectrum Plot of Worst Value

802.11a_Chain 1 / CH149

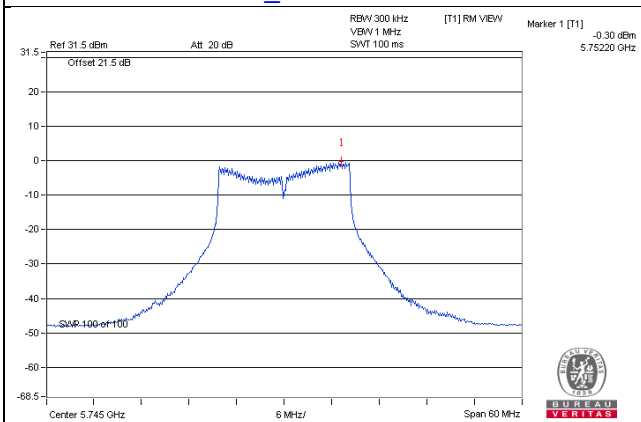

802.11ac (VHT20)_Chain 1 / CH149

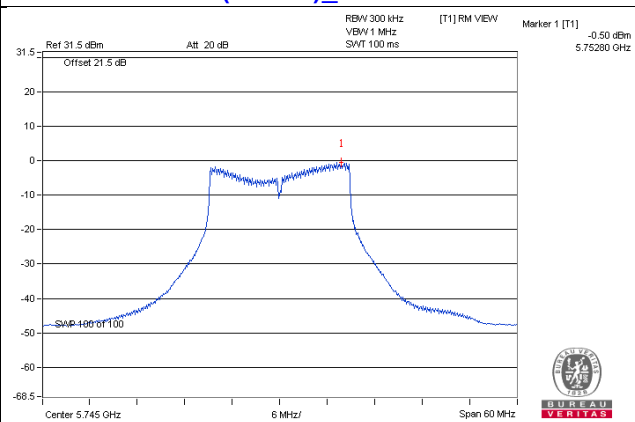

802.11ac (VHT40)_Chain 1 / CH151

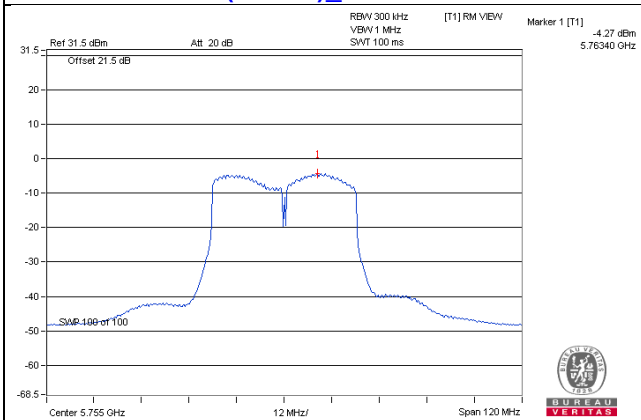

802.11ac (VHT80)_Chain 1 / CH155

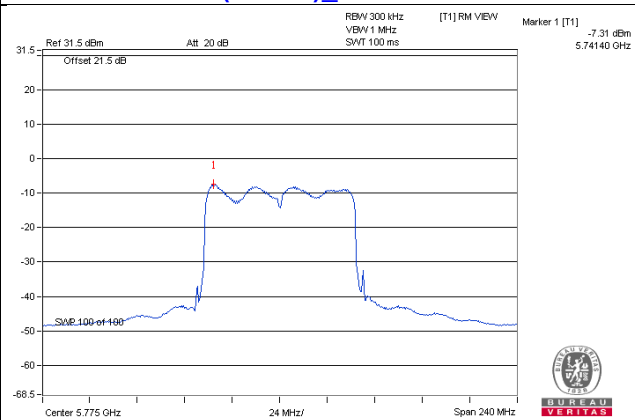

4.6 Frequency Stability Measurement

4.6.1 Limits of Frequency Stability Measurement

The frequency of the carrier signal shall be maintained within band of operation

4.6.2 Test Setup

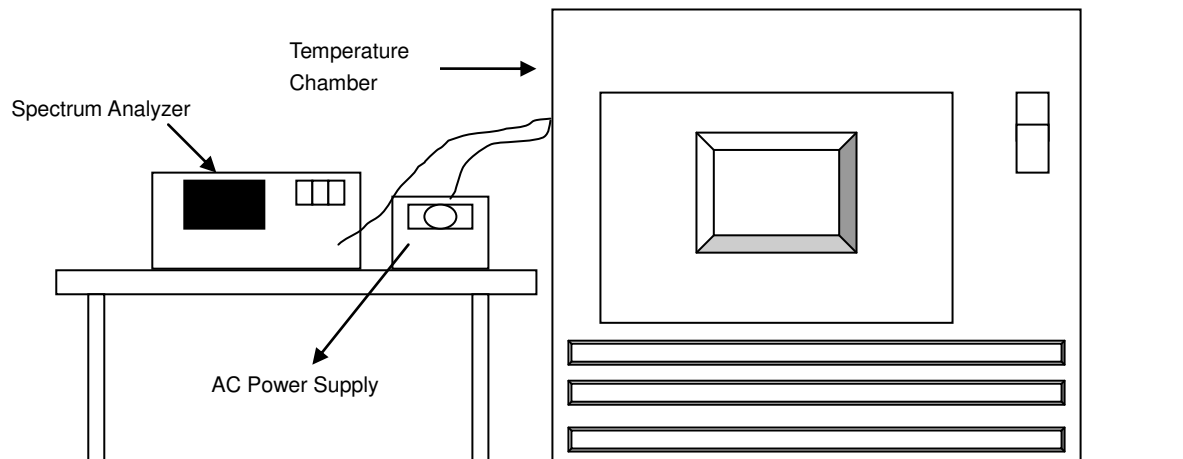

4.6.3 Test Instruments

Refer to section 4.1.2 to get information of above instrument.

4.6.4 Test Procedure

- The EUT was placed inside the environmental test chamber and powered by nominal AC voltage.
- Turn the EUT on and couple its output to a spectrum analyzer.
- Turn the EUT off and set the chamber to the highest temperature specified.
- Allow sufficient time (approximately 30 min) for the temperature of the chamber to stabilize, turn the EUT on and measure the operating frequency after 2, 5, and 10 Minutes.
- Repeat step 2 and 3 with the temperature chamber set to the lowest temperature.
- The test chamber was allowed to stabilize at +20 degree C for a minimum of 30 Minutes. The supply voltage was then adjusted on the EUT from 85% to 115% and the frequency record.

4.6.5 Deviation from Test Standard

No deviation.

4.6.6 EUT Operating Condition

Set the EUT transmit at un-modulation mode to test frequency stability.

4.6.7 Test Results

Frequency Stability Versus Temp.									
Operating Frequency: 5180 MHz									
TEMP. (°C)	Power Supply (Vac)	0 Minute		2 Minute		5 Minute		10 Minute	
		Measured Frequency (MHz)	Pass/Fail	Measured Frequency (MHz)	Pass/Fail	Measured Frequency (MHz)	Pass/Fail	Measured Frequency (MHz)	Pass/Fail
50	120	5179.9981	Pass	5179.9989	Pass	5179.9993	Pass	5179.9984	Pass
40	120	5179.9743	Pass	5179.9748	Pass	5179.9744	Pass	5179.9769	Pass
30	120	5180.0217	Pass	5180.018	Pass	5180.021	Pass	5180.0215	Pass
20	120	5180.0048	Pass	5180.0092	Pass	5180.0056	Pass	5180.0049	Pass
10	120	5180.0169	Pass	5180.0189	Pass	5180.0184	Pass	5180.0169	Pass
0	120	5179.9774	Pass	5179.9757	Pass	5179.9737	Pass	5179.9748	Pass
-10	120	5180.0081	Pass	5180.006	Pass	5180.0063	Pass	5180.0083	Pass
-20	120	5179.9923	Pass	5179.9879	Pass	5179.9885	Pass	5179.9907	Pass
-30	120	5180.008	Pass	5180.0104	Pass	5180.0088	Pass	5180.0111	Pass

Frequency Stability Versus Voltage									
Operating Frequency: 5180 MHz									
TEMP. (°C)	Power Supply (Vac)	0 Minute		2 Minute		5 Minute		10 Minute	
		Measured Frequency (MHz)	Pass/Fail	Measured Frequency (MHz)	Pass/Fail	Measured Frequency (MHz)	Pass/Fail	Measured Frequency (MHz)	Pass/Fail
20	138	5180.0053	Pass	5180.0084	Pass	5180.006	Pass	5180.0042	Pass
	120	5180.0048	Pass	5180.0092	Pass	5180.0056	Pass	5180.0049	Pass
	102	5180.0053	Pass	5180.0093	Pass	5180.005	Pass	5180.0048	Pass

4.7 6dB Bandwidth Measurement

4.7.1 Limits of 6dB Bandwidth Measurement

The minimum of 6dB Bandwidth Measurement is 0.5MHz.

4.7.2 Test Setup

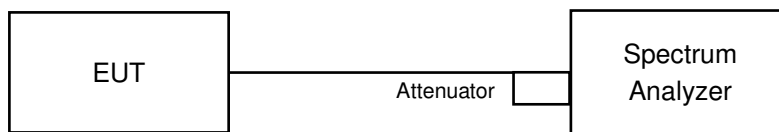

4.7.3 Test Instruments

Refer to section 4.1.2 to get information of above instrument.

4.7.4 Test Procedure

MEASUREMENT PROCEDURE REF

- Set resolution bandwidth (RBW) = 100kHz
- Set the video bandwidth (VBW) $\geq 3 \times$ RBW, Detector = Peak.
- Trace mode = max hold.
- Sweep = auto couple.
- Measure the maximum width of the emission that is constrained by the frequencies associated with the two amplitude points (upper and lower) that are attenuated by 6 dB relative to the maximum level measured in the fundamental emission

4.7.5 Deviation from Test Standard

No deviation.

4.7.6 EUT Operating Condition

The software provided by client to enable the EUT under transmission condition continuously at lowest, middle and highest channel frequencies individually.

4.7.7 Test Results

802.11a

Channel	Frequency (MHz)	6dB Bandwidth (MHz)				Minimum Limit (MHz)	Pass / Fail
		Chain 0	Chain 1	Chain 2	Chain 3		
149	5745	16.40	16.46	16.44	16.43	0.5	Pass
157	5785	16.41	16.47	16.42	16.46	0.5	Pass
165	5825	16.41	16.39	16.41	16.44	0.5	Pass

802.11ac (VHT20)

Channel	Frequency (MHz)	6dB Bandwidth (MHz)				Minimum Limit (MHz)	Pass / Fail
		Chain 0	Chain 1	Chain 2	Chain 3		
149	5745	17.71	17.68	17.72	17.72	0.5	Pass
157	5785	17.82	17.85	17.71	17.80	0.5	Pass
165	5825	17.84	17.71	17.69	17.70	0.5	Pass

802.11ac (VHT40)

Channel	Frequency (MHz)	6dB Bandwidth (MHz)				Minimum Limit (MHz)	Pass / Fail
		Chain 0	Chain 1	Chain 2	Chain 3		
151	5755	36.49	35.72	36.48	36.57	0.5	Pass
159	5795	36.49	36.11	36.48	36.50	0.5	Pass

802.11ac (VHT80)

Channel	Frequency (MHz)	6dB Bandwidth (MHz)				Minimum Limit (MHz)	Pass / Fail
		Chain 0	Chain 1	Chain 2	Chain 3		
155	5775	75.67	72.83	75.50	75.84	0.5	Pass

Spectrum Plot of Worst Value

802.11a / Chain 1 : CH165

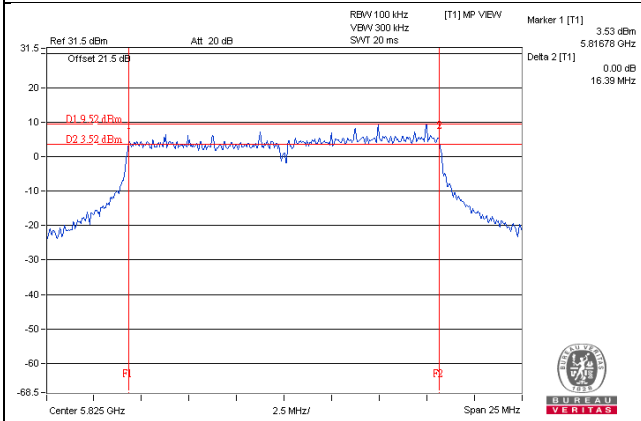

802.11ac(VHT20) / Chain 1 : CH149

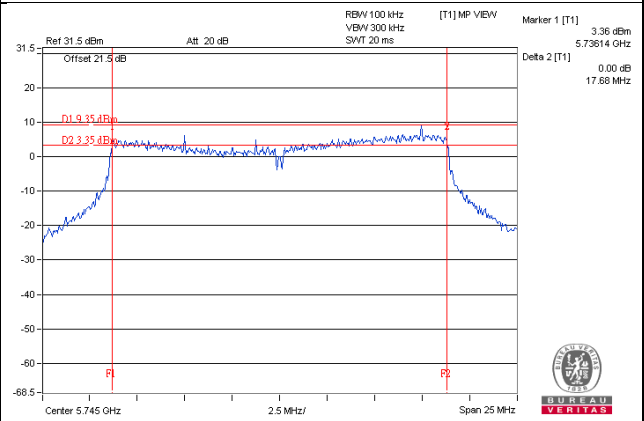

802.11ac(VHT40) / Chain 1 : CH151

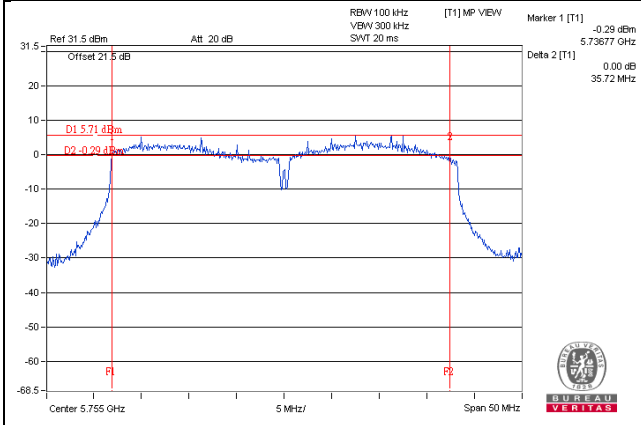

802.11ac(VHT80) / Chain 1 : CH155

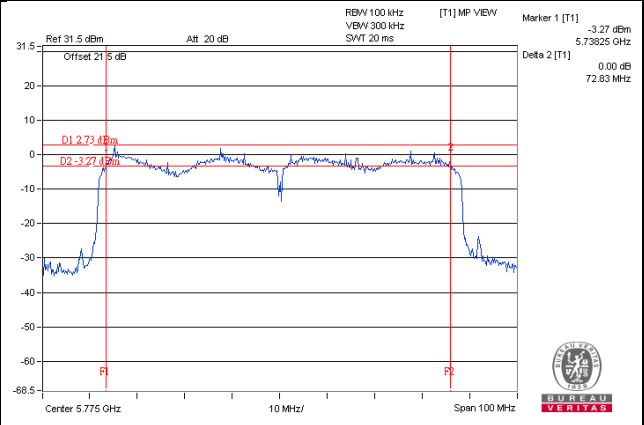

5 Pictures of Test Arrangements

Please refer to the attached file (Test Setup Photo).

Annex A- Radiated Out of Band Emission (OOBE) Measurement (For U-NII-3 band)

802.11a

CH 149 5745 MHz

Horizontal

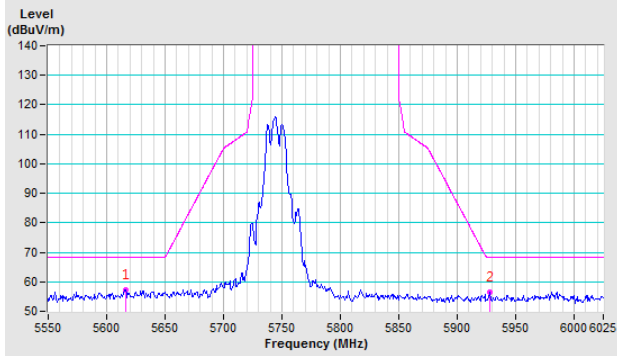

Vertical

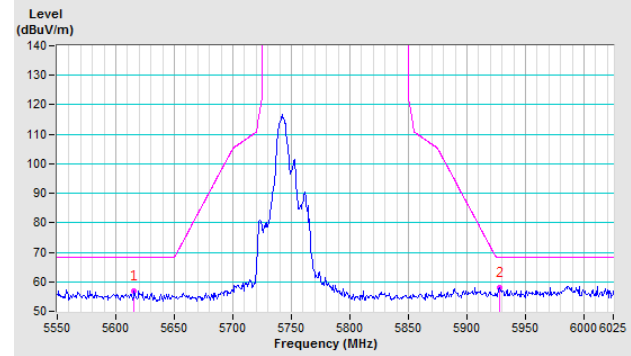

CH 157 5785 MHz

Horizontal

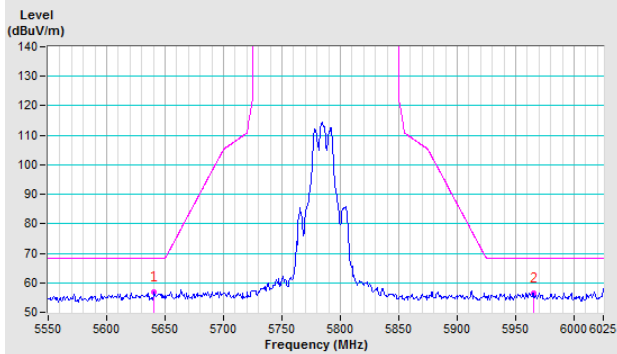

Vertical

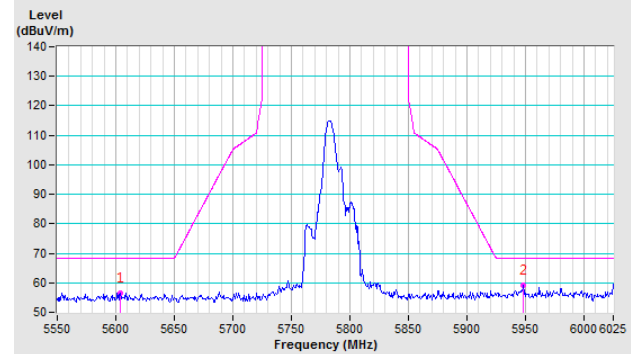

CH 165 5825 MHz

Horizontal

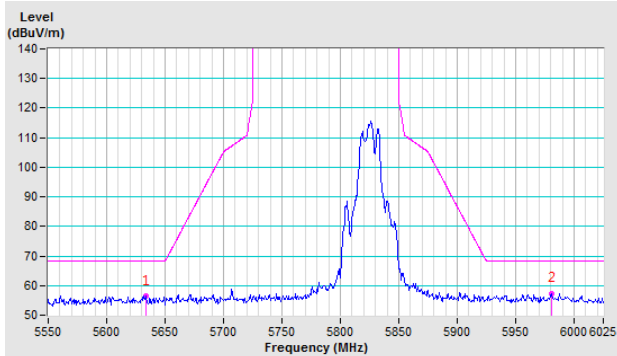

Vertical

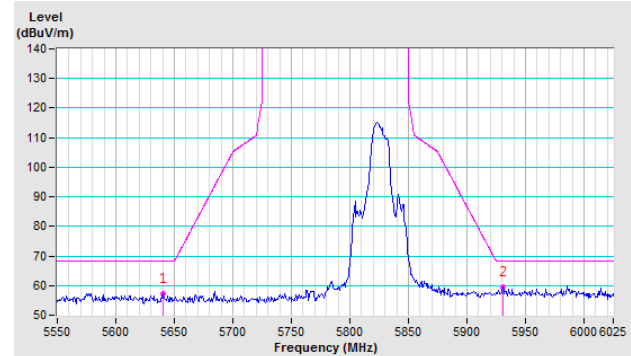

802.11ac (VHT20)

CH 149 5745 MHz

Horizontal

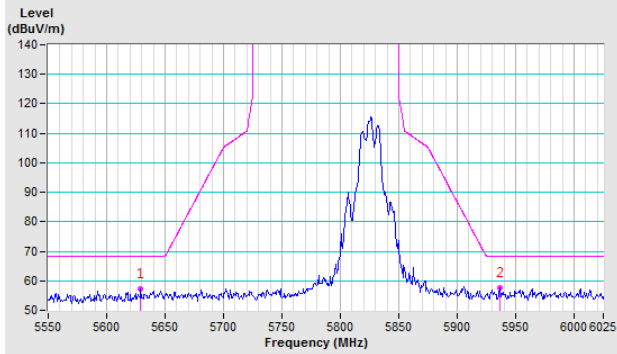

Vertical

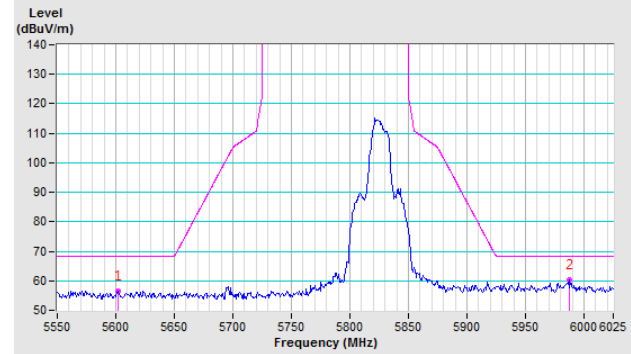

CH 157 5785 MHz

Horizontal

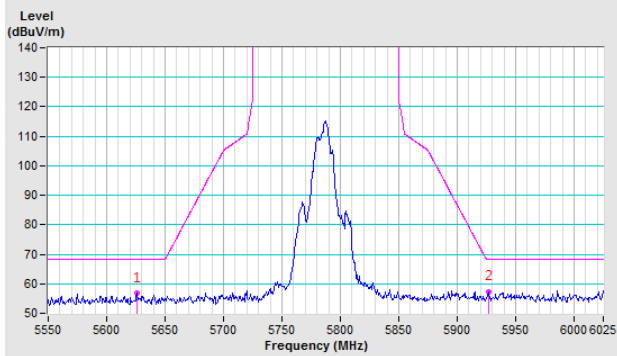

Vertical

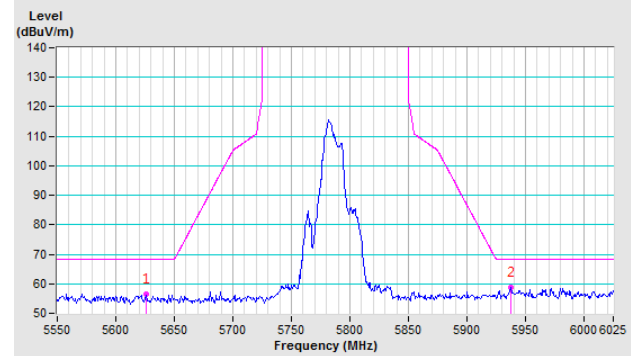

CH 165 5825 MHz

Horizontal

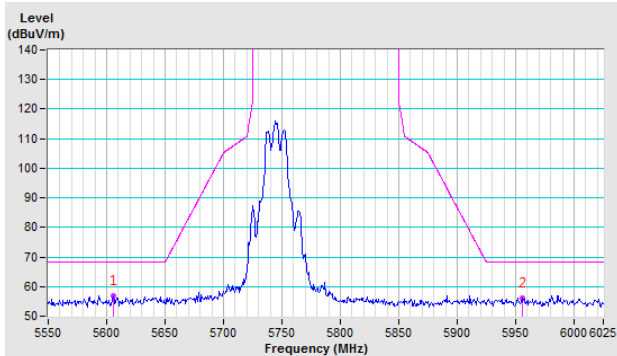

Vertical

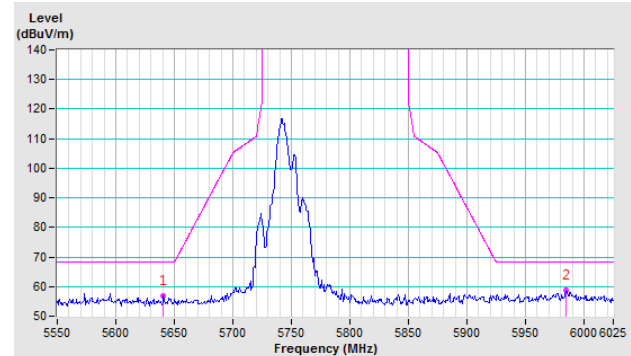

802.11ac (VHT40)

CH 151 5755 MHz

Horizontal

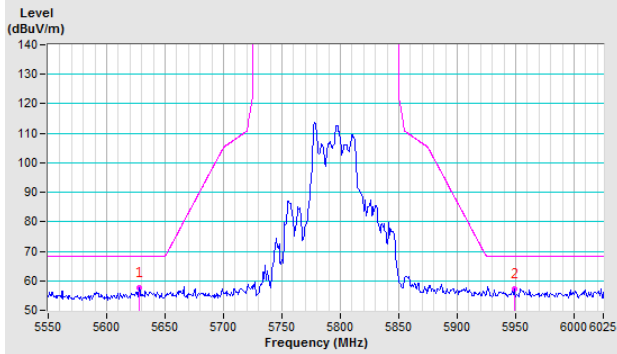

Vertical

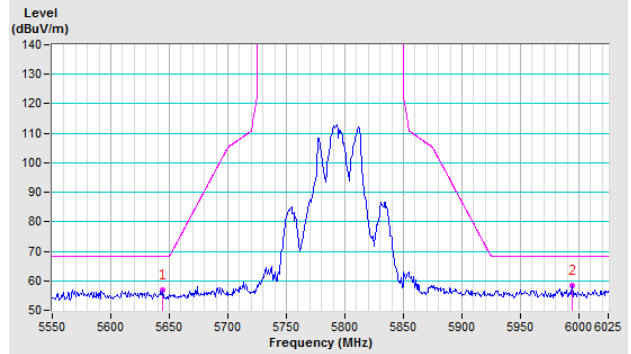

CH 159 5795 MHz

Horizontal

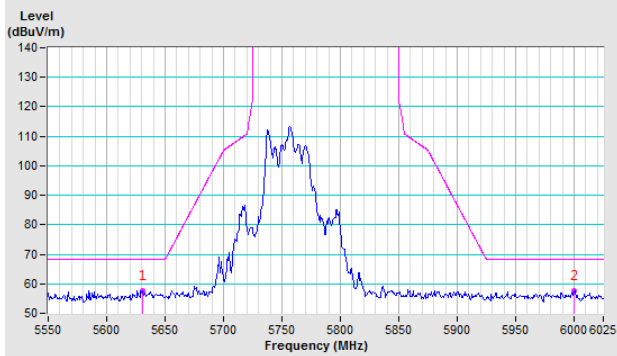

Vertical

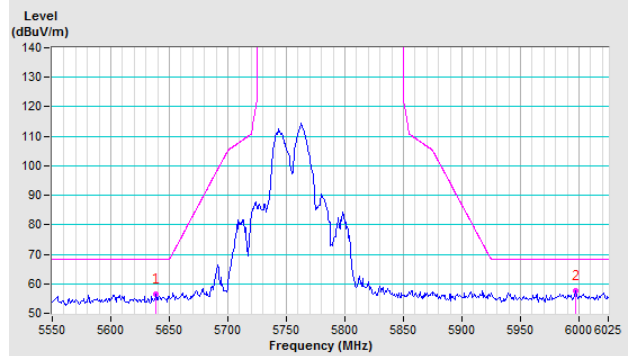

802.11ac (VHT80)

CH 155 5775 MHz

Horizontal

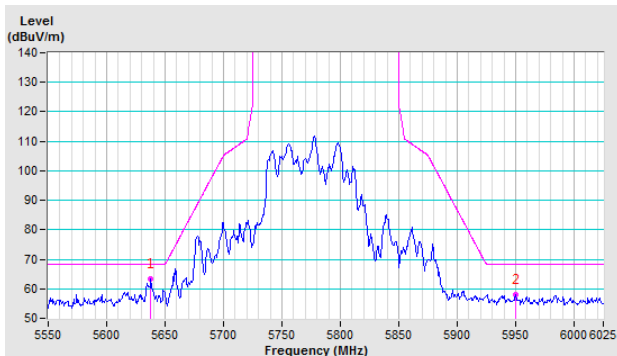

Vertical

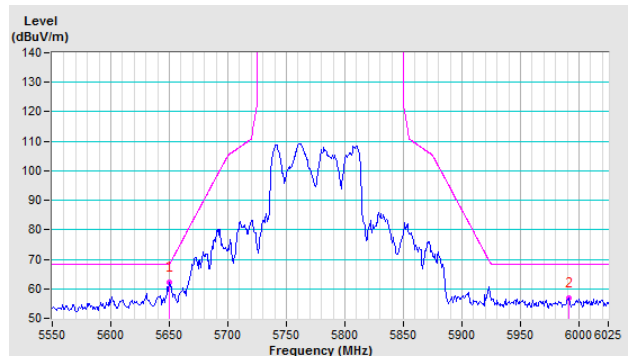

Appendix – Information on the Testing Laboratories

We, Bureau Veritas Consumer Products Services (H.K.) Ltd., Taoyuan Branch, were founded in 1988 to provide our best service in EMC, Radio, Telecom and Safety consultation. Our laboratories are accredited and approved according to ISO/IEC 17025.

If you have any comments, please feel free to contact us at the following:

Linko EMC/RF Lab

Tel: 886-2-26052180

Fax: 886-2-26051924

Hsin Chu EMC/RF/Telecom Lab

Tel: 886-3-6668565

Fax: 886-3-6668323

Hwa Ya EMC/RF/Safety Lab

Tel: 886-3-3183232

Fax: 886-3-3270892

Email: service.adt@tw.bureauveritas.com

Web Site: www.bureauveritas-adt.com

The address and road map of all our labs can be found in our web site also.

--- END ---