

RF TEST REPORT

Applicant	Fibocom Wireless Inc.
FCC ID	ZMOFG101NA
Product	LTE Module
Brand	Fibocom
Model	FG101-NA
Report No.	R2404A0415-R2V2
Issue Date	May 14, 2024

Eurofins TA Technology (Shanghai) Co., Ltd. tested the above equipment in accordance with the requirements in **FCC CFR47 Part 2 (2023)/ FCC CFR47 Part 27C (2023)**. The test results show that the equipment tested is capable of demonstrating compliance with the requirements as documented in this report.

Prepared by: Zhu Chentao

Approved by: Xu Kai

Eurofins TA Technology (Shanghai) Co., Ltd.

Building 3, No.145, Jintang Rd, Pudong Shanghai, P.R.China

TEL: +86-021-50791141/2/3

FAX: +86-021-50791141/2/3-8000

TABLE OF CONTENT

1	Test Laboratory	6
1.1	Notes of the Test Report.....	6
1.2.	Test facility	6
1.3	Testing Location.....	6
2	General Description of Equipment under Test	7
2.1	Applicant and Manufacturer Information	7
2.2	General information	7
3	Applied Standards	8
4	Test Configuration	9
5	Test Case	10
5.1	RF Power Output and Effective Isotropic Radiated Power	10
5.2	Radiated Spurious Emission	12
6	Test Results	15
6.1	RF Power Output and Effective Isotropic Radiated Power	15
6.2	Radiated Spurious Emission	32
7	Main Test Instruments	40
	ANNEX A: The EUT Appearance	41
	ANNEX B: Test Setup Photos	42
	ANNEX C: Product Change Description	43

Version	Revision Description	Issue Date
Rev.0	Initial issue of report.	May 9, 2024
Rev.1	Update description.	May 13, 2024
Rev.2	Update information	May 14, 2024

Note: This revised report (Report No.: R2404A0415-R2V2) supersedes and replaces the previously issued report (Report No.: R2404A0415-R2V1). Please discard or destroy the previously issued report and dispose of it accordingly.

Summary of Measurement Results

Number	Test Case	Clause in FCC rules	Verdict
1	RF Power Output and Effective Isotropic Radiated Power	2.1046 /27.50(d)(4) /27.50(c)(10) /27.50(h)(2)	PASS
2	Occupied Bandwidth	2.1049	Not Test ¹
3	Band Edge Compliance	27.53(h) /27.53(g) /27.53(m)	Not Test ¹
4	Peak-to-Average Power Ratio	27.50(d)/KDB971168 D01(5.7)	Not Test ¹
5	Frequency Stability	2.1055 / 27.54	Not Test ¹
6	Spurious Emissions at Antenna Terminals	2.1051 /27.53(h) /27.53(g) /27.53(m)	Not Test ¹
7	Radiated Spurious Emission	2.1053 /27.53(h) /27.53(g) /27.53(m)	PASS

Date of Testing: April 19, 2024 ~ April 23, 2024

Date of Sample Received: April 15, 2024

Note: PASS: The EUT complies with the essential requirements in the standard.

FAIL: The EUT does not comply with the essential requirements in the standard.

1. Not Test means after evaluation, test items are no need to test, the test results please refer to Original Report.

2. All indications of Pass/Fail in this report are opinions expressed by Eurofins TA Technology (Shanghai) Co., Ltd. based on interpretations and/or observations of test results. Measurement Uncertainties were not taken into account and are published for informational purposes only.

FG101-NA (Report No.: R2404A0415-R2V2) is a variant model of FG101-NA (Report No.: SZ23060216W05 and SZ23060216W02).

The detailed product change description please refers to following table:

Different	Original	Variant
Band	WCDMA Band II/IV/V LTE Band 2/4/5/7/12/13/14/17/25/26/30/41/48/66/71	WCDMA Band II/V LTE Band 4/5/12/41/66
Antenna Gain	WCDMA Band II: 2.20 dBi LTE Band 17: 2.20 dBi WCDMA Band IV: 4.07 dBi LTE Band 25: 4.07 dBi WCDMA Band V: 4.07 dBi LTE Band 26: 2.20 dBi LTE Band 2: 4.07 dBi LTE Band 30: 0.22 dBi LTE Band 4: 4.07 dBi LTE Band 41: 4.07 dBi LTE Band 5: 2.20 dBi LTE Band 48: -1.18 dBi LTE Band 7: 4.07 dBi LTE Band 66: 4.07 dBi LTE Band 12: 2.20 dBi LTE Band 71: 2.20 dBi LTE Band 13: 2.20 dBi	WCDMA Band II: 2.79 dBi WCDMA Band V: 0.69 dBi LTE Band 4: 3.32 dBi LTE Band 5: 0.69 dBi LTE Band 12: 0 dBi LTE Band 41: 4.07 dBi LTE Band 66: 3.32 dBi

This report only test Radiated Spurious Emission and because of the change of antenna gain, Effective Radiated Power also re-evaluated.

This report is used in conjunction with the original report (Report No.: SZ23060216W05 and SZ23060216W02).

The detailed product change description please refers to the Difference Declaration Letter.

1 Test Laboratory

1.1 Notes of the Test Report

This report shall not be reproduced in full or partial, without the written approval of **Eurofins TA Technology (Shanghai) Co., Ltd.** The results documented in this report apply only to the tested sample, under the conditions and modes of operation as described herein. Measurement Uncertainties were not taken into account and are published for informational purposes only. This report is written to support regulatory compliance of the applicable standards stated above.

1.2. Test facility

FCC (Designation number: CN1179, Test Firm Registration Number: 446626)

Eurofins TA Technology (Shanghai) Co., Ltd. has been listed on the US Federal Communications Commission list of test facilities recognized to perform measurements.

A2LA (Certificate Number: 3857.01)

Eurofins TA Technology (Shanghai) Co., Ltd. has been listed by American Association for Laboratory Accreditation to perform measurement.

1.3 Testing Location

Company: Eurofins TA Technology (Shanghai) Co., Ltd.
Address: Building 3, No.145, Jintang Rd, Pudong Shanghai, P.R.China
City: Shanghai
Post code: 201201
Country: P. R. China
Contact: Xu Kai
Telephone: +86-021-50791141/2/3
Fax: +86-021-50791141/2/3-8000
Website: <https://www.eurofins.com/electrical-and-electronics>
E-mail: Kain.Xu@cpt.eurofinscn.com

2 General Description of Equipment under Test

2.1 Applicant and Manufacturer Information

Applicant	Fibocom Wireless Inc.
Applicant address	1101, Tower A, Building 6, Shenzhen International Innovation Valley, Dashi 1st Rd, Nanshan, Shenzhen, China
Manufacturer	Fibocom Wireless Inc.
Manufacturer address	1101, Tower A, Building 6, Shenzhen International Innovation Valley, Dashi 1st Rd, Nanshan, Shenzhen, China

2.2 General information

EUT Description			
Model	FG101-NA		
Lab internal SN	R2404A0415/S01		
Hardware Version	V1.2		
Software Version	19101.1000.01.00.00.07		
Power Supply	AC adapter		
Antenna Type	Fixed External Antenna		
Antenna Gain	LTE Band 4: 3.32 dBi LTE Band 12: 0 dBi LTE Band 41: 4.07 dBi LTE Band 66: 3.32 dBi		
Test Mode(s)	LTE Band 4/12/41/66; CA_41C		
Test Modulation	(LTE) QPSK, 16QAM, 64QAM		
Maximum E.I.R.P./ E.R.P.	LTE Band 4:	26.14 dBm	
	LTE Band 12:	21.10 dBm	
	LTE Band 41 (Power Class 2):	29.75 dBm	
	LTE Band 41 (Power Class 3):	27.33 dBm	
	LTE Band 66:	26.13 dBm	
	CA_41C:	28.70 dBm	
Rated Power Supply Voltage	12V		
Operating Frequency Range(s)	Mode	Tx (MHz)	Rx (MHz)
	LTE Band 4	1710 ~ 1755	2110 ~ 2155
	LTE Band 12	699 ~ 716	729 ~ 746
	LTE Band 41	2496 ~ 2690	2496 ~ 2690
	LTE Band 66	1710 ~ 1780	2110 ~ 2180
Host Equipment	Manufacturer: Shanghai Smawave Technology Co. ,Ltd Product Name: Cat12 Indoor CPE Model: SC421		
Note: 1. The EUT is sent from the applicant to Eurofins TA and the information of the EUT is declared by the applicant.			

3 Applied Standards

According to the specifications of the manufacturer, it must comply with the requirements of the following standards:

Test standards:

FCC CFR47 Part 27C (2023)

FCC CFR47 Part 2 (2023)

Reference standard:

ANSI C63.26-2015

KDB 971168 D01 Power Meas License Digital Systems v03r01

4 Test Configuration

Radiated measurements are performed by rotating the EUT in three different orthogonal test planes. EUT stand-up position (vertical), lie-down position (horizontal). Receiver antenna polarization (horizontal and vertical), the worst emission was found in position (vertical, vertical polarization for LTE Band; horizontal, horizontal polarization for CA Band) and the worst case was recorded.

All mode and data rates and positions and RB size and modulations were investigated.

Subsequently, only the worst case emissions are reported.

The following testing in LTE is set based on the maximum RF Output Power.

The following testing in different Bandwidth is set to detail in the following table:

Test modes are chosen to be reported as the worst case configuration below for LTE Band 4/12/41/61:

Test items	Modes	Bandwidth (MHz)						Modulation		RB			Test Channel		
		1.4	3	5	10	15	20	QPSK	16QAM/ 64QAM	1	50%	100%	L	M	H
RF Power Output and Effective Isotropic Radiated Power	LTE 4	O	O	O	O	O	O	O	O	O	O	O	O	O	O
	LTE 12	O	O	O	O	-	-	O	O	O	O	O	O	O	O
	LTE 41	-	-	O	O	O	O	O	O	O	O	O	O	O	O
	LTE 66	O	O	O	O	O	O	O	O	O	O	O	O	O	O
Radiated Spurious Emission	LTE 4	O	-	O	-	-	O	O	-	O	-	-	-	O	-
	LTE 12	O	-	O	O	-	-	O	-	O	-	-	-	O	-
	LTE 41	-	-	O	-	-	O	O	-	O	-	-	-	O	-
	LTE 66	O	-	O	-	-	O	O	-	O	-	-	-	O	-
Note	1. The mark "O" means that this configuration is chosen for testing. 2. The mark "-" means that this configuration is not testing.														

5 Test Case

5.1 RF Power Output and Effective Isotropic Radiated Power

Ambient condition

Temperature	Relative humidity	Pressure
15°C ~ 35°C	20% ~ 80%	86 kPa ~ 106 kPa

Methods of Measurement

During the process of the testing, The EUT was connected to the Base Station Simulator with a known loss. The EUT is controlled by the Base Station Simulator test set to ensure max power transmission with proper modulation.

ERP can then be calculated as follows:

$$\text{EIRP (dBm)} = \text{Output Power (dBm)} + \text{Antenna Gain (dBi)}$$

$$\text{EIRP (dBm)} = \text{ERP (dBm)} + 2.15 \text{ (dB.)}$$

Test Setup

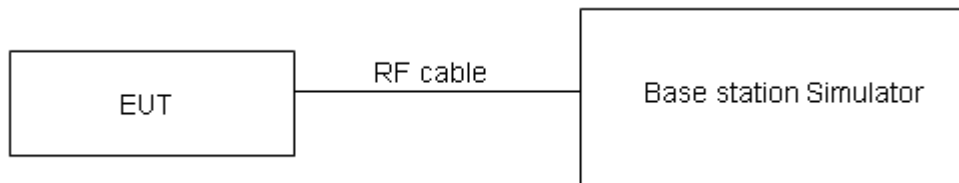

Limits

No specific RF power output requirements in part 2.1046.

Rule Part 27.50(c) (10) specifies that “Portable stations (hand-held devices) in the 600 MHz uplink band and the 698-746 MHz band, and fixed and mobile stations in the 600 MHz uplink band are limited to 3 watts ERP”

Rule Part 27.50(d) (4) specifies that “Fixed, mobile and portable (hand-held) stations operating in the 1710–1755 MHz band are limited to 1 watt EIRP”

Rule Part 27.50(h) (2) specifies that “Mobile and other user stations. Mobile stations are limited to 2.0 watts EIRP. All user stations are limited to 2.0 watts transmitter output power.”

Part 27.50(c)(10)Limit	≤ 3 W (34.77 dBm)
Part 27.50(d)(4)Limit	≤ 1 W (30 dBm)
Part 27.50(h)(2) Limit	≤ 2 W (33 dBm)

Measurement Uncertainty

The assessed measurement uncertainty to ensure 95% confidence level for the normal distribution is with the coverage factor $k = 2$, $U=0.4$ dB for RF power output, $k = 2$, $U= 1.19$ dB for ERP/EIRP.

Test Results

Refer to the section 6.1 of this report for test data.

5.2 Radiated Spurious Emission

Ambient condition

Temperature	Relative humidity	Pressure
15°C ~ 35°C	20% ~ 80%	86 kPa ~ 106 kPa

Method of Measurement

- The testing follows FCC KDB 971168 D01 v03r01 Section 5.8 and ANSI C63.26-2015.
- Below 1GHz: The EUT is placed on a turntable 0.8 meters above the ground in the chamber, 3 meter away from the antenna. The maximal emission value is acquired by adjusting the antenna height, polarisation and turntable azimuth. Normally, the height range of antenna is 1 m to 4 m, the azimuth range of turntable is 0° to 360°, and the receive antenna has two polarizations Vertical (V) and Horizontal (H). Above 1GHz: (Note: the FCC's permission to use 1.5m as an alternative per TCBC Conf call of Dec. 2, 2014.) The EUT is placed on a turntable 1.5 meters above the ground in the chamber, 3 meter away from the antenna. The maximal emission value is acquired by adjusting the antenna height, polarisation and turntable azimuth. Normally, the height range of antenna is 1 m to 4 m, the azimuth range of turntable is 0° to 360°, and the receive antenna has two polarizations Vertical (V) and Horizontal (H).
- A loop antenna, A log-periodic antenna or horn antenna shall be substituted in place of the EUT. The log-periodic antenna will be driven by a signal generator and the level will be adjusted till the same power value on the spectrum analyzer or receiver. The level of the spurious emissions can be calculated through the level of the signal generator, cable loss, the gain of the substitution antenna and the reading of the spectrum analyzer or receiver.
- The EUT is then put into continuously transmitting mode at its maximum power level during the test. Set Test Receiver or Spectrum RBW=100kHz, VBW=300kHz for 30MHz to 1GHz and RBW=1MHz, VBW=3MHz for above 1GHz, and the maximum value of the receiver should be recorded as (Pr).
- The EUT shall be replaced by a substitution antenna. In the chamber, an substitution antenna for the frequency band of interest is placed at the reference point of the chamber. An RF Signal source for the frequency band of interest is connected to the substitution antenna with a cable that has been constructed to not interfere with the radiation pattern of the antenna. A power (PMea) is applied to the input of the substitution antenna, and adjust the level of the signal generator output until the value of the receiver reach the previously recorded (Pr). The power of signal source (PMea) is recorded. The test should be performed by rotating the test item and adjusting the receiving antenna polarization.
- A amplifier should be connected to the Signal Source output port. And the cable should be connect between the Amplifier and the Substitution Antenna. The cable loss (Pcl) ,the Substitution Antenna Gain (Ga) and the Amplifier Gain (PAg) should be recorded after test.
- The measurement results are obtained as described below:
 $Power(EIRP)=PMea- PAg - Pcl + Ga$
 The measurement results are amend as described below:
 $Power(EIRP)=PMea- Pcl + Ga$
- This value is EIRP since the measurement is calibrated using an antenna of known gain (2.15 dB) and known input power. ERP can be calculated from EIRP by subtracting the gain of the dipole, $ERP = EIRP-2.15dB$.

The modulation mode and RB allocation refer to section 5.1, using the maximum output power configuration.

Test setup

9KHz~ 30MHz

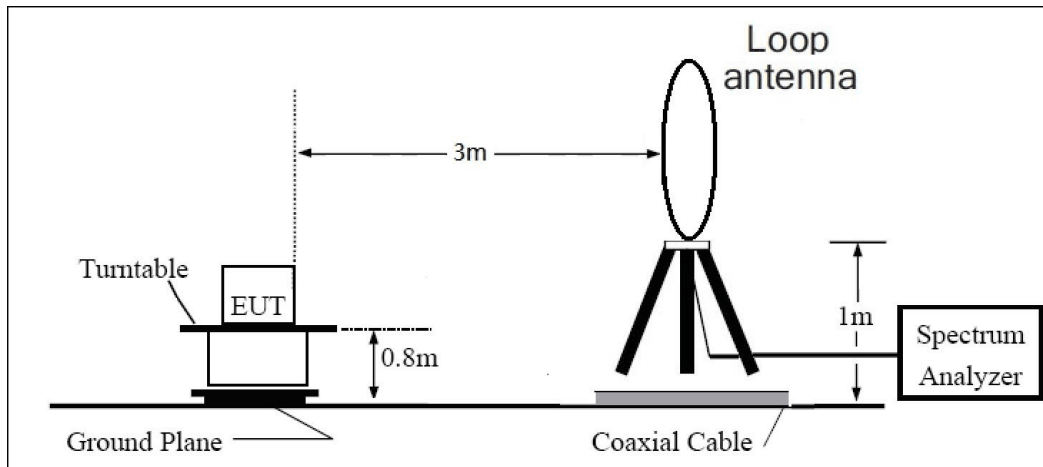

30MHz~ 1GHz

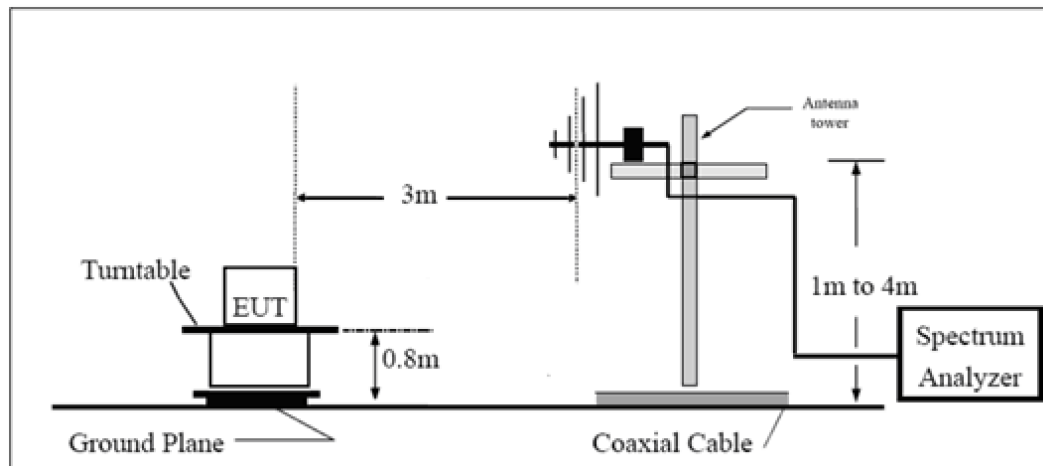

Above 1GHz

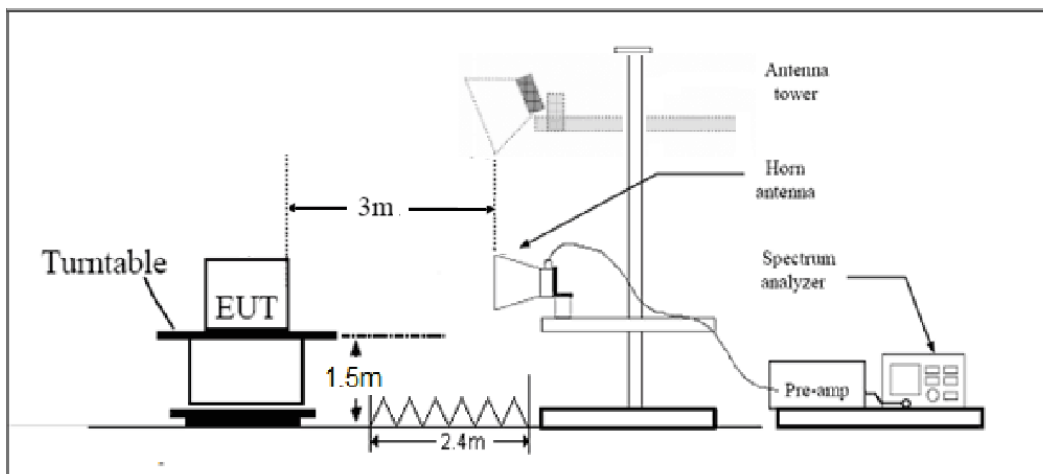

Note: Area side:2.4mX3.6m

Limits

Rule Part 27.53(h) specifies that “for operations in the 1695-1710 MHz, 1710-1755 MHz, 1755-1780 MHz, 1915-1920 MHz, 1995-2000 MHz, 2000-2020 MHz, 2110-2155 MHz, 2155-2180 MHz, and 2180-2200 bands, the power of any emission outside a licensee's frequency block shall be attenuated below the transmitter power (P) in watts by at least $43 + 10 \log_{10}(P)$ dB.”

Rule Part 27.53 (g) For operations in the 600 MHz band and the 698-746 MHz band, the power of any emission outside a licensee's frequency band(s) of operation shall be attenuated below the transmitter power (P) within the licensed band(s) of operation, measured in watts, by at least $43 + 10 \log(P)$ dB. Compliance with this provision is based on the use of measurement instrumentation employing a resolution bandwidth of 100 kilohertz or greater. However, in the 100 kilohertz bands immediately outside and adjacent to a licensee's frequency block, a resolution bandwidth of at least 30 kHz may be employed.

Rule Part 27.53(m) $55 + 10 \log(P)$ dB on all frequencies more than X megahertz from the channel edge, where X is the greater of 6 megahertz or the actual emission bandwidth as defined in paragraph (m)(4) of this section.

Part 27.53 (h)/(g) Limit		-13 dBm
Part 27.53(f) Limit	Limit out of the band 1559-1610 MHz	-13 dBm
	Limit in the band 1559-1610 MHz	-40 dBm
Part 27.53(m) Limit		-25 dBm

Measurement Uncertainty

The assessed measurement uncertainty to ensure 95% confidence level for the normal distribution is with the coverage factor $k = \pm 1.96$, $U = \pm 3.55$ dB.

Test Results

Refer to the section 6.2 of this report for test data.

6 Test Results

6.1 RF Power Output and Effective Isotropic Radiated Power

The RF Power Output comes from original report. (Report No.: SZ23060216W05 and SZ23060216W02).

LTE Band 4				Maximum Output Power(dBm)			EIRP (dBm)		
BW	Modulation	RB size	RB offset	Channel/Frequency(MHz)					
				19957/ 1710.7	20175/ 1732.5	20393/ 1754.3	19957/ 1710.7	20175/ 1732.5	20393/ 1754.3
1.4MHz	QPSK	1	0	22.77	22.75	22.76	26.09	26.07	26.08
		1	3	22.71	22.66	22.68	26.03	25.98	26.00
		1	5	22.72	22.74	22.65	26.04	26.06	25.97
		3	0	21.90	21.79	21.88	25.22	25.11	25.20
		3	1	21.85	21.63	21.76	25.17	24.95	25.08
		3	3	21.81	21.77	21.66	25.13	25.09	24.98
		6	0	21.82	21.87	21.75	25.14	25.19	25.07
	16QAM	1	0	21.89	21.84	21.73	25.21	25.16	25.05
		1	3	21.85	21.82	21.86	25.17	25.14	25.18
		1	5	21.82	21.71	21.72	25.14	25.03	25.04
		3	0	20.71	20.90	20.69	24.03	24.22	24.01
		3	1	20.94	20.89	20.78	24.26	24.21	24.10
		3	3	20.92	20.67	20.76	24.24	23.99	24.08
		6	0	20.62	20.86	20.94	23.94	24.18	24.26
	64QAM	1	0	20.80	20.87	20.73	24.12	24.19	24.05
		1	3	20.82	20.94	20.75	24.14	24.26	24.07
		1	5	20.96	20.93	20.97	24.28	24.25	24.29
		3	0	19.76	19.74	19.79	23.08	23.06	23.11
		3	1	19.91	19.56	19.72	23.23	22.88	23.04
		3	3	19.83	19.85	19.80	23.15	23.17	23.12
		6	0	19.84	19.82	19.97	23.16	23.14	23.29
BW	Modulation	RB size	RB offset	Channel/Frequency(MHz)					
				19965/ 1711.5	20175/ 1732.5	20385/ 1753.5	19965/ 1711.5	20175/ 1732.5	20385/ 1753.5
3MHz	QPSK	1	0	22.78	22.76	22.66	26.10	26.08	25.98
		1	8	22.69	22.73	22.71	26.01	26.05	26.03

		1	14	22.65	22.64	22.67	25.97	25.96	25.99	
		8	0	21.76	21.81	21.64	25.08	25.13	24.96	
		8	4	21.80	21.79	21.80	25.12	25.11	25.12	
		8	7	21.84	21.57	21.67	25.16	24.89	24.99	
		15	0	21.76	21.76	21.64	25.08	25.08	24.96	
	16QAM	1	0	21.92	21.90	21.89	25.24	25.22	25.21	
		1	8	21.87	21.75	21.85	25.19	25.07	25.17	
		1	14	21.86	21.91	21.60	25.18	25.23	24.92	
		8	0	20.92	20.84	20.77	24.24	24.16	24.09	
		8	4	20.83	20.70	20.81	24.15	24.02	24.13	
		8	7	20.69	20.61	20.73	24.01	23.93	24.05	
	64QAM	15	0	20.70	20.65	20.71	24.02	23.97	24.03	
		1	0	20.94	20.92	20.75	24.26	24.24	24.07	
		1	8	20.86	20.74	20.80	24.18	24.06	24.12	
		1	14	20.82	20.72	20.86	24.14	24.04	24.18	
		8	0	19.89	19.93	19.57	23.21	23.25	22.89	
		8	4	19.85	19.79	19.76	23.17	23.11	23.08	
		8	7	19.52	19.55	19.56	22.84	22.87	22.88	
	15	0	19.86	19.83	19.83	23.18	23.15	23.15		
	BW	Modulation	RB size	RB offset	Channel/Frequency(MHz)					
					19975/ 1712.5	20175/ 1732.5	20375/ 1752.5	19975/ 1712.5	20175/ 1732.5	20375/ 1752.5
5MHz	QPSK	1	0	22.80	22.79	22.72	26.12	26.11	26.04	
		1	12	22.68	22.73	22.72	26.00	26.05	26.04	
		1	24	22.68	22.71	22.51	26.00	26.03	25.83	
		12	0	21.92	21.92	21.75	25.24	25.24	25.07	
		12	7	21.73	21.82	21.69	25.05	25.14	25.01	
		12	13	21.85	21.78	21.52	25.17	25.10	24.84	
		25	0	21.65	21.87	21.67	24.97	25.19	24.99	
	16QAM	1	0	21.85	21.91	21.86	25.17	25.23	25.18	
		1	12	21.79	21.92	21.72	25.11	25.24	25.04	
		1	24	21.77	21.67	21.76	25.09	24.99	25.08	
		12	0	20.91	20.86	20.76	24.23	24.18	24.08	
		12	7	20.75	20.79	20.81	24.07	24.11	24.13	
		12	13	20.67	20.84	20.77	23.99	24.16	24.09	
	25	0	20.89	20.61	20.72	24.21	23.93	24.04		
64QAM	1	0	20.95	20.91	20.96	24.27	24.23	24.28		

BW	Modulation	RB size	RB offset	Channel/Frequency(MHz)						
				20000/1715	20175/1732.5	20350/1750	20000/1715	20175/1732.5	20350/1750	
		1	12	20.92	20.83	20.96	24.24	24.15	24.28	
		1	24	20.84	20.85	20.91	24.16	24.17	24.23	
		12	0	19.83	19.95	19.98	23.15	23.27	23.30	
		12	7	19.94	19.60	19.97	23.26	22.92	23.29	
		12	13	19.77	19.78	19.70	23.09	23.10	23.02	
		25	0	19.80	19.86	19.85	23.12	23.18	23.17	
10MHz	QPSK	1	0	22.79	22.77	22.74	26.11	26.09	26.06	
		1	25	22.77	22.71	22.60	26.09	26.03	25.92	
		1	49	22.61	22.54	22.75	25.93	25.86	26.07	
		25	0	21.85	21.76	21.84	25.17	25.08	25.16	
		25	12	21.79	21.77	21.79	25.11	25.09	25.11	
		25	25	21.63	21.79	21.60	24.95	25.11	24.92	
		50	0	21.84	21.76	21.78	25.16	25.08	25.10	
	16QAM	1	0	21.92	21.95	21.83	25.24	25.27	25.15	
		1	25	21.86	21.82	21.83	25.18	25.14	25.15	
		1	49	21.92	21.77	21.85	25.24	25.09	25.17	
		25	0	20.65	20.84	20.63	23.97	24.16	23.95	
		25	12	20.90	20.86	20.85	24.22	24.18	24.17	
		25	25	20.86	20.84	20.86	24.18	24.16	24.18	
		50	0	20.83	20.83	20.67	24.15	24.15	23.99	
	64QAM	1	0	20.84	20.81	20.90	24.16	24.13	24.22	
		1	25	20.73	20.76	20.90	24.05	24.08	24.22	
		1	49	20.97	20.86	20.75	24.29	24.18	24.07	
		25	0	19.98	19.93	19.79	23.30	23.25	23.11	
		25	12	19.86	19.73	19.62	23.18	23.05	22.94	
		25	25	19.92	19.69	19.63	23.24	23.01	22.95	
		50	0	19.68	19.84	19.69	23.00	23.16	23.01	
	BW	Modulation	RB size	RB offset	Channel/Frequency(MHz)					
					20025/1717.5	20175/1732.5	20325/1747.5	20025/1717.5	20175/1732.5	20325/1747.5
	15MHz	QPSK	1	0	22.78	22.75	22.72	26.10	26.07	26.04
1			37	22.72	22.60	22.70	26.04	25.92	26.02	
1			74	22.63	22.72	22.62	25.95	26.04	25.94	
36			0	21.90	21.80	21.73	25.22	25.12	25.05	

BW	Modulation	RB size	RB offset	Channel/Frequency(MHz)						
				20050/ 1720	20175/ 1732.5	20300/ 1745	20050/ 1720	20175/ 1732.5	20300/ 1745	
	16QAM	36	20	21.88	21.74	21.77	25.20	25.06	25.09	
		36	39	21.74	21.63	21.66	25.06	24.95	24.98	
		75	0	21.83	21.60	21.71	25.15	24.92	25.03	
		1	0	21.85	21.88	21.75	25.17	25.20	25.07	
		1	37	21.78	21.85	21.63	25.10	25.17	24.95	
		1	74	21.71	21.73	21.70	25.03	25.05	25.02	
		36	0	20.78	20.77	20.81	24.10	24.09	24.13	
		36	20	20.68	20.74	20.70	24.00	24.06	24.02	
		36	39	20.64	20.65	20.53	23.96	23.97	23.85	
	75	0	20.73	20.55	20.71	24.05	23.87	24.03		
	64QAM	1	0	20.90	20.85	20.81	24.22	24.17	24.13	
		1	37	20.83	20.81	20.73	24.15	24.13	24.05	
		1	74	20.84	20.65	20.76	24.16	23.97	24.08	
		36	0	19.80	19.72	19.64	23.12	23.04	22.96	
		36	20	19.71	19.84	19.89	23.03	23.16	23.21	
		36	39	19.89	19.75	19.63	23.21	23.07	22.95	
		75	0	19.82	19.81	19.79	23.14	23.13	23.11	
	20MHz	QPSK	1	0	22.82	22.80	22.76	26.14	26.12	26.08
			1	49	22.80	22.66	22.68	26.12	25.98	26.00
			1	99	22.71	22.56	22.51	26.03	25.88	25.83
			50	0	21.85	21.77	21.81	25.17	25.09	25.13
50			24	21.74	21.78	21.80	25.06	25.10	25.12	
50			50	21.76	21.75	21.66	25.08	25.07	24.98	
100			0	21.70	21.70	21.61	25.02	25.02	24.93	
16QAM		1	0	21.88	21.87	21.70	25.20	25.19	25.02	
		1	49	21.70	21.83	21.61	25.02	25.15	24.93	
		1	99	21.71	21.80	21.58	25.03	25.12	24.90	
		50	0	20.79	20.76	20.86	24.11	24.08	24.18	
		50	24	20.86	20.70	20.72	24.18	24.02	24.04	
		50	50	20.56	20.66	20.54	23.88	23.98	23.86	
		100	0	20.83	20.77	20.78	24.15	24.09	24.10	
64QAM		1	0	20.95	20.89	20.75	24.27	24.21	24.07	
		1	49	20.96	20.91	20.89	24.28	24.23	24.21	
		1	99	20.86	20.76	21.01	24.18	24.08	24.33	

		50	0	19.88	19.85	19.76	23.20	23.17	23.08
		50	24	19.74	19.84	19.92	23.06	23.16	23.24
		50	50	19.76	19.57	19.89	23.08	22.89	23.21
		100	0	19.84	19.77	19.54	23.16	23.09	22.86

LTE Band 12				Maximum Output Power(dBm)			ERP (dBm)		
BW	Modulation	RB size	RB offset	Channel/Frequency(MHz)					
				23017/ 699.7	23095/ 707.5	23173/ 715.3	23017/ 699.7	23095/ 707.5	23173/ 715.3
1.4MHz	QPSK	1	0	23.16	23.17	23.19	21.01	21.02	21.04
		1	3	23.07	23.17	23.07	20.92	21.02	20.92
		1	5	23.05	23.07	23.18	20.90	20.92	21.03
		3	0	22.28	22.33	22.34	20.13	20.18	20.19
		3	1	22.26	22.30	22.31	20.11	20.15	20.16
		3	3	22.23	22.13	22.17	20.08	19.98	20.02
		6	0	22.28	22.39	22.17	20.13	20.24	20.02
	16QAM	1	0	22.27	22.33	22.42	20.12	20.18	20.27
		1	3	22.07	22.34	22.37	19.92	20.19	20.22
		1	5	22.09	22.33	22.40	19.94	20.18	20.25
		3	0	21.15	21.19	21.20	19.00	19.04	19.05
		3	1	21.12	21.13	21.29	18.97	18.98	19.14
		3	3	21.10	21.25	21.27	18.95	19.10	19.12
		6	0	21.21	21.09	21.02	19.06	18.94	18.87
	64QAM	1	0	21.27	21.25	21.37	19.12	19.10	19.22
		1	3	21.12	21.29	21.28	18.97	19.14	19.13
		1	5	21.08	21.19	21.13	18.93	19.04	18.98
		3	0	20.03	20.27	20.18	17.88	18.12	18.03
		3	1	20.14	20.20	20.13	17.99	18.05	17.98
		3	3	20.20	20.06	20.24	18.05	17.91	18.09
		6	0	20.09	20.26	20.31	17.94	18.11	18.16
BW	Modulation	RB size	RB offset	Channel/Frequency(MHz)					
				23025/ 700.5	23095/ 707.5	23165/ 714.5	23025/ 700.5	23095/ 707.5	23165/ 714.5
3MHz	QPSK	1	0	23.16	23.20	23.20	21.01	21.05	21.05
		1	8	23.15	23.05	23.18	21.00	20.90	21.03
		1	14	23.05	23.12	23.02	20.90	20.97	20.87
		8	0	22.16	22.20	22.14	20.01	20.05	19.99

BW	Modulation	RB size	RB offset	Channel/Frequency(MHz)						
				23035/ 701.5	23095/ 707.5	23155/ 713.5	23035/ 701.5	23095/ 707.5	23155/ 713.5	
		8	4	22.10	22.23	22.17	19.95	20.08	20.02	
		8	7	22.19	22.20	22.10	20.04	20.05	19.95	
		15	0	22.03	22.16	22.18	19.88	20.01	20.03	
		16QAM	1	0	22.24	22.29	22.35	20.09	20.14	20.20
			1	8	22.16	22.33	22.36	20.01	20.18	20.21
			1	14	22.07	22.36	22.31	19.92	20.21	20.16
			8	0	21.07	21.38	21.12	18.92	19.23	18.97
			8	4	21.30	21.31	21.33	19.15	19.16	19.18
			8	7	21.12	21.15	21.20	18.97	19.00	19.05
	15		0	21.11	21.03	21.01	18.96	18.88	18.86	
	64QAM	1	0	21.31	21.36	21.24	19.16	19.21	19.09	
		1	8	21.26	21.29	21.41	19.11	19.14	19.26	
		1	14	21.11	21.36	21.37	18.96	19.21	19.22	
		8	0	20.31	20.11	20.20	18.16	17.96	18.05	
		8	4	20.01	20.31	20.34	17.86	18.16	18.19	
		8	7	20.05	20.20	20.15	17.90	18.05	18.00	
		15	0	20.03	20.36	20.19	17.88	18.21	18.04	
	5MHz	QPSK	1	0	23.13	23.12	23.22	20.98	20.97	21.07
			1	12	23.19	23.15	23.19	21.04	21.00	21.04
			1	24	23.19	23.17	23.14	21.04	21.02	20.99
			12	0	22.12	22.15	22.26	19.97	20.00	20.11
			12	7	22.10	22.21	22.14	19.95	20.06	19.99
			12	13	22.03	22.22	22.18	19.88	20.07	20.03
			25	0	22.14	22.07	22.12	19.99	19.92	19.97
		16QAM	1	0	22.35	22.35	22.30	20.20	20.20	20.15
			1	12	22.28	22.21	22.32	20.13	20.06	20.17
			1	24	22.24	22.32	22.18	20.09	20.17	20.03
			12	0	21.15	21.13	21.18	19.00	18.98	19.03
12			7	20.97	21.16	21.28	18.82	19.01	19.13	
12			13	21.14	21.07	21.26	18.99	18.92	19.11	
25			0	20.99	21.24	21.05	18.84	19.09	18.90	
64QAM		1	0	21.24	21.26	21.32	19.09	19.11	19.17	
		1	12	21.22	21.18	21.17	19.07	19.03	19.02	
		1	24	21.23	21.17	21.16	19.08	19.02	19.01	

BW	Modulation	RB size	RB offset	Channel/Frequency(MHz)					
				23060/ 704	23095/ 707.5	23130/ 711	23060/ 704	23095/ 707.5	23130/ 711
				12	0	20.10	20.11	20.37	17.95
		12	7	20.05	20.19	20.29	17.90	18.04	18.14
		12	13	20.07	20.04	20.05	17.92	17.89	17.90
		25	0	20.06	20.25	20.22	17.91	18.10	18.07
10MHz	QPSK	1	0	23.17	23.13	23.25	21.02	20.98	21.10
		1	25	23.20	23.17	23.12	21.05	21.02	20.97
		1	49	23.12	23.06	23.22	20.97	20.91	21.07
		25	0	22.34	22.31	22.40	20.19	20.16	20.25
		25	12	22.19	22.26	22.15	20.04	20.11	20.00
		25	25	22.11	22.24	22.10	19.96	20.09	19.95
		50	0	22.26	22.19	22.17	20.11	20.04	20.02
	16QAM	1	0	22.21	22.41	22.45	20.06	20.26	20.30
		1	25	22.28	22.23	22.36	20.13	20.08	20.21
		1	49	22.31	22.33	22.23	20.16	20.18	20.08
		25	0	21.31	21.15	21.35	19.16	19.00	19.20
		25	12	21.07	21.36	21.12	18.92	19.21	18.97
		25	25	21.13	21.05	21.26	18.98	18.90	19.11
		50	0	21.22	21.32	21.21	19.07	19.17	19.06
	64QAM	1	0	21.25	21.35	21.39	19.10	19.20	19.24
		1	25	21.24	21.30	21.22	19.09	19.15	19.07
		1	49	21.14	21.31	21.28	18.99	19.16	19.13
		25	0	20.29	20.22	20.26	18.14	18.07	18.11
		25	12	20.24	20.31	20.34	18.09	18.16	18.19
		25	25	20.17	20.29	20.22	18.02	18.14	18.07
		50	0	20.10	20.22	20.10	17.95	18.07	17.95

LTE Band 41 (Power Class 2)				Maximum Output Power(dBm)			EIRP (dBm)		
BW	Modulation	RB size	RB offset	Channel/Frequency(MHz)					
				39675/ 2498.5	40620/ 2593	41565/ 2687.5	39675/ 2498.5	40620/ 2593	41565/ 2687.5
5MHz	QPSK	1	0	25.62	25.60	25.60	29.69	29.67	29.67
		1	12	25.46	25.43	25.59	29.53	29.50	29.66
		1	24	25.60	25.34	25.45	29.67	29.41	29.52

		12	0	24.54	24.45	24.48	28.61	28.52	28.55	
		12	7	24.52	24.55	24.58	28.59	28.62	28.65	
		12	13	24.65	24.61	24.58	28.72	28.68	28.65	
		25	0	24.62	24.38	24.59	28.69	28.45	28.66	
	16QAM	1	0	24.72	24.70	24.66	28.79	28.77	28.73	
		1	12	24.76	24.64	24.65	28.83	28.71	28.72	
		1	24	24.69	24.64	24.69	28.76	28.71	28.76	
		12	0	23.61	23.63	23.72	27.68	27.70	27.79	
		12	7	23.59	23.59	23.54	27.66	27.66	27.61	
		12	13	23.44	23.52	23.44	27.51	27.59	27.51	
	64QAM	25	0	23.37	23.62	23.45	27.44	27.69	27.52	
		1	0	23.81	23.87	23.80	27.88	27.94	27.87	
		1	12	23.56	23.67	23.52	27.63	27.74	27.59	
		1	24	23.61	23.75	23.50	27.68	27.82	27.57	
		12	0	22.57	22.63	22.70	26.64	26.70	26.77	
		12	7	22.42	22.59	22.69	26.49	26.66	26.76	
	10MHz	QPSK	12	13	22.57	22.40	22.63	26.64	26.47	26.70
			25	0	22.61	22.46	22.36	26.68	26.53	26.43
	16QAM		1	0	25.57	25.62	25.53	29.64	29.69	29.60
			1	25	25.49	25.59	25.41	29.56	29.66	29.48
	64QAM		1	49	25.44	25.60	25.63	29.51	29.67	29.70
25			0	24.62	24.58	24.77	28.69	28.65	28.84	
25			12	24.72	24.49	24.43	28.79	28.56	28.50	
25		25	24.61	24.43	24.41	28.68	28.50	28.48		
50		0	24.64	24.63	24.45	28.71	28.70	28.52		
16QAM		1	0	24.60	24.64	24.72	28.67	28.71	28.79	
		1	25	24.73	24.70	24.77	28.80	28.77	28.84	
	1	49	24.67	24.53	24.66	28.74	28.60	28.73		
	25	0	23.52	23.64	23.43	27.59	27.71	27.50		
	25	12	23.60	23.67	23.65	27.67	27.74	27.72		
	25	25	23.47	23.51	23.37	27.54	27.58	27.44		
	50	0	23.58	23.62	23.48	27.65	27.69	27.55		
64QAM	1	0	23.64	23.88	23.70	27.71	27.95	27.77		
	1	25	23.55	23.54	23.60	27.62	27.61	27.67		
BW	Modulation	RB size	RB offset	Channel/Frequency(MHz)						
				39700/ 2501	40620/ 2593	41540/ 2685	39700/ 2501	40620/ 2593	41540/ 2685	

BW	Modulation	RB size	RB offset	Channel/Frequency(MHz)						
				39725/ 2503.5	40620/ 2593	41515/ 2682.5	39725/ 2503.5	40620/ 2593	41515/ 2682.5	
		1	49	23.75	23.60	23.64	27.82	27.67	27.71	
		25	0	22.42	22.62	22.56	26.49	26.69	26.63	
		25	12	22.43	22.57	22.65	26.50	26.64	26.72	
		25	25	22.46	22.52	22.31	26.53	26.59	26.38	
		50	0	22.65	22.47	22.67	26.72	26.54	26.74	
15MHz	QPSK	1	0	25.56	25.65	25.40	29.63	29.72	29.47	
		1	37	25.43	25.42	25.57	29.50	29.49	29.64	
		1	74	25.35	25.34	25.63	29.42	29.41	29.70	
		36	0	24.51	24.79	24.80	28.58	28.86	28.87	
		36	20	24.51	24.61	24.62	28.58	28.68	28.69	
		36	39	24.50	24.65	24.54	28.57	28.72	28.61	
		75	0	24.37	24.66	24.55	28.44	28.73	28.62	
	16QAM	1	0	24.69	24.82	24.62	28.76	28.89	28.69	
		1	37	24.63	24.56	24.71	28.70	28.63	28.78	
		1	74	24.46	24.53	24.64	28.53	28.60	28.71	
		36	0	23.55	23.64	23.54	27.62	27.71	27.61	
		36	20	23.65	23.59	23.57	27.72	27.66	27.64	
		36	39	23.54	23.30	23.31	27.61	27.37	27.38	
		75	0	23.34	23.36	23.58	27.41	27.43	27.65	
	64QAM	1	0	23.82	23.83	23.62	27.89	27.90	27.69	
		1	37	23.50	23.70	23.58	27.57	27.77	27.65	
		1	74	23.62	23.68	23.68	27.69	27.75	27.75	
		36	0	22.47	22.53	22.72	26.54	26.60	26.79	
		36	20	22.44	22.67	22.48	26.51	26.74	26.55	
		36	39	22.57	22.55	22.37	26.64	26.62	26.44	
		75	0	22.42	22.40	22.61	26.49	26.47	26.68	
			RB size	RB offset	Channel/Frequency(MHz)					
					39750/ 2506	40620/ 2593	41490/ 2680	39750/ 2506	40620/ 2593	41490/ 2680
	20MHz	QPSK	1	0	25.60	25.68	25.42	29.67	29.75	29.49
1			49	25.63	25.40	25.55	29.70	29.47	29.62	
1			99	25.42	25.54	25.47	29.49	29.61	29.54	
50			0	24.61	24.80	24.60	28.68	28.87	28.67	
50			24	24.65	24.65	24.70	28.72	28.72	28.77	

		50	50	24.58	24.62	24.57	28.65	28.69	28.64
		100	0	24.65	24.52	24.69	28.72	28.59	28.76
	16QAM	1	0	24.55	24.64	24.70	28.62	28.71	28.77
			49	24.84	24.68	24.56	28.91	28.75	28.63
		1	99	24.52	24.67	24.72	28.59	28.74	28.79
			0	23.62	23.61	23.67	27.69	27.68	27.74
		50	24	23.58	23.46	23.43	27.65	27.53	27.50
			50	23.49	23.60	23.53	27.56	27.67	27.60
		100	0	23.45	23.58	23.48	27.52	27.65	27.55
	64QAM	1	0	23.56	23.81	23.68	27.63	27.88	27.75
			49	23.67	23.77	23.54	27.74	27.84	27.61
		1	99	23.61	23.58	23.73	27.68	27.65	27.80
			0	22.54	22.52	22.46	26.61	26.59	26.53
		50	24	22.43	22.54	22.47	26.50	26.61	26.54
			50	22.42	22.63	22.48	26.49	26.70	26.55
		100	0	22.49	22.58	22.56	26.56	26.65	26.63

LTE Band 41 (Power Class 3)				Maximum Output Power(dBm)			EIRP (dBm)		
BW	Modulation	RB size	RB offset	Channel/Frequency(MHz)					
				39675/ 2498.5	40620/ 2593	41565/ 2687.5	39675/ 2498.5	40620/ 2593	41565/ 2687.5
5MHz	QPSK	1	0	23.12	23.19	22.99	27.19	27.26	27.06
		1	12	23.02	23.19	22.95	27.09	27.26	27.02
		1	24	23.12	23.08	23.03	27.19	27.15	27.10
		12	0	22.09	22.23	22.09	26.16	26.30	26.16
		12	7	22.11	22.05	22.21	26.18	26.12	26.28
		12	13	21.95	22.00	22.11	26.02	26.07	26.18
		25	0	22.15	22.18	22.14	26.22	26.25	26.21
	16QAM	1	0	22.14	22.11	22.13	26.21	26.18	26.20
		1	12	22.02	22.05	22.01	26.09	26.12	26.08
		1	24	22.17	22.16	21.95	26.24	26.23	26.02
		12	0	21.16	21.00	21.13	25.23	25.07	25.20
		12	7	20.90	20.95	21.12	24.97	25.02	25.19
		12	13	21.01	21.04	21.04	25.08	25.11	25.11
		25	0	20.95	21.15	20.84	25.02	25.22	24.91
	64QAM	1	0	21.22	21.15	21.09	25.29	25.22	25.16

BW	Modulation	RB size	RB offset	Channel/Frequency(MHz)						
				39700/ 2501	40620/ 2593	41540/ 2685	39700/ 2501	40620/ 2593	41540/ 2685	
				1	12	21.28	21.25	21.08	25.35	25.32
1	24	21.16	21.04	21.02	25.23	25.11	25.09			
12	0	19.97	20.05	20.16	24.04	24.12	24.23			
12	7	20.14	20.13	20.00	24.21	24.20	24.07			
12	13	20.14	20.09	20.15	24.21	24.16	24.22			
25	0	20.02	20.01	20.04	24.09	24.08	24.11			
10MHz	QPSK	1	0	23.14	23.16	23.01	27.21	27.23	27.08	
		1	25	22.89	22.97	23.03	26.96	27.04	27.10	
		1	49	22.89	23.05	22.93	26.96	27.12	27.00	
		25	0	22.12	22.16	22.20	26.19	26.23	26.27	
		25	12	22.24	22.04	21.90	26.31	26.11	25.97	
		25	25	22.05	22.15	22.06	26.12	26.22	26.13	
		50	0	22.15	22.00	22.10	26.22	26.07	26.17	
	16QAM	1	0	22.35	22.38	22.35	26.42	26.45	26.42	
		1	25	22.17	22.04	22.03	26.24	26.11	26.10	
		1	49	22.09	22.24	22.26	26.16	26.31	26.33	
		25	0	20.97	21.15	21.04	25.04	25.22	25.11	
		25	12	21.19	20.95	21.12	25.26	25.02	25.19	
		25	25	20.95	20.99	20.93	25.02	25.06	25.00	
		50	0	20.89	21.15	20.89	24.96	25.22	24.96	
	64QAM	1	0	21.27	21.19	21.16	25.34	25.26	25.23	
		1	25	21.18	21.03	21.05	25.25	25.10	25.12	
		1	49	21.07	21.18	21.13	25.14	25.25	25.20	
		25	0	20.07	20.21	20.18	24.14	24.28	24.25	
		25	12	20.16	19.98	19.87	24.23	24.05	23.94	
		25	25	19.90	20.11	19.95	23.97	24.18	24.02	
		50	0	20.12	19.96	20.07	24.19	24.03	24.14	
	BW	Modulation	RB size	RB offset	Channel/Frequency(MHz)					
					39725/ 2503.5	40620/ 2593	41515/ 2682.5	39725/ 2503.5	40620/ 2593	41515/ 2682.5
	15MHz	QPSK	1	0	23.05	23.20	23.04	27.12	27.27	27.11
1			37	22.89	22.97	22.97	26.96	27.04	27.04	
1			74	22.88	23.14	22.98	26.95	27.21	27.05	
36			0	22.28	22.23	22.01	26.35	26.30	26.08	

		36	20	22.06	22.19	21.94	26.13	26.26	26.01
		36	39	21.98	22.04	21.92	26.05	26.11	25.99
		75	0	22.19	21.91	22.03	26.26	25.98	26.10
	16QAM	1	0	22.16	22.28	22.17	26.23	26.35	26.24
		1	37	22.20	22.27	22.23	26.27	26.34	26.30
		1	74	22.20	22.12	22.26	26.27	26.19	26.33
		36	0	20.95	21.15	21.08	25.02	25.22	25.15
		36	20	20.95	21.18	21.13	25.02	25.25	25.20
		36	39	20.84	20.87	20.96	24.91	24.94	25.03
		75	0	21.16	21.17	21.01	25.23	25.24	25.08
	64QAM	1	0	21.02	21.07	21.11	25.09	25.14	25.18
		1	37	21.27	21.08	21.22	25.34	25.15	25.29
		1	74	20.93	21.17	21.05	25.00	25.24	25.12
		36	0	20.09	20.24	20.26	24.16	24.31	24.33
		36	20	20.19	20.06	20.13	24.26	24.13	24.20
		36	39	19.93	20.15	20.08	24.00	24.22	24.15
		75	0	20.19	20.21	19.97	24.26	24.28	24.04
	BW	Modulation	RB size	RB offset	Channel/Frequency(MHz)				
39750/2506					40620/2593	41490/2680	39750/2506	40620/2593	41490/2680
20MHz	QPSK	1	0	23.20	23.26	23.15	27.27	27.33	27.22
		1	49	23.05	23.10	23.03	27.12	27.17	27.10
		1	99	23.06	23.11	23.00	27.13	27.18	27.07
		50	0	22.27	22.33	22.18	26.34	26.40	26.25
		50	24	22.07	22.19	22.02	26.14	26.26	26.09
		50	50	22.14	22.09	22.06	26.21	26.16	26.13
		100	0	22.09	22.10	21.89	26.16	26.17	25.96
	16QAM	1	0	22.25	22.31	22.17	26.32	26.38	26.24
		1	49	22.25	22.11	22.06	26.32	26.18	26.13
		1	99	22.19	22.00	22.16	26.26	26.07	26.23
		50	0	21.02	21.22	21.08	25.09	25.29	25.15
		50	24	20.99	21.07	21.06	25.06	25.14	25.13
		50	50	20.90	21.10	21.01	24.97	25.17	25.08
		100	0	21.02	21.07	20.95	25.09	25.14	25.02
	64QAM	1	0	21.20	21.41	21.37	25.27	25.48	25.44
		1	49	21.25	21.26	21.05	25.32	25.33	25.12
		1	99	21.19	21.09	21.03	25.26	25.16	25.10

		50	0	19.94	20.15	20.18	24.01	24.22	24.25
		50	24	19.86	20.13	19.88	23.93	24.20	23.95
		50	50	20.14	19.99	19.81	24.21	24.06	23.88
		100	0	19.86	19.87	19.93	23.93	23.94	24.00

LTE Band 66				Maximum Output Power(dBm)			EIRP (dBm)		
BW	Modulation	RB size	RB offset	Channel/Frequency(MHz)					
				131979/ 1710.7	132322/ 1745	132665/ 1779.3	131979/ 1710.7	132322/ 1745	132665/ 1779.3
1.4MHz	QPSK	1	0	22.70	22.76	22.65	26.02	26.08	25.97
		1	3	22.57	22.72	22.69	25.89	26.04	26.01
		1	5	22.60	22.65	22.61	25.92	25.97	25.93
		3	0	21.65	21.72	21.67	24.97	25.04	24.99
		3	1	21.66	21.65	21.86	24.98	24.97	25.18
		3	3	21.73	21.80	21.69	25.05	25.12	25.01
		6	0	21.77	21.60	21.80	25.09	24.92	25.12
	16QAM	1	0	21.81	21.83	21.79	25.13	25.15	25.11
		1	3	21.69	21.82	21.74	25.01	25.14	25.06
		1	5	21.55	21.87	21.77	24.87	25.19	25.09
		3	0	20.57	20.76	20.71	23.89	24.08	24.03
		3	1	20.65	20.85	20.85	23.97	24.17	24.17
		3	3	20.52	20.69	20.83	23.84	24.01	24.15
		6	0	20.65	20.83	20.68	23.97	24.15	24.00
	64QAM	1	0	20.71	20.86	20.80	24.03	24.18	24.12
		1	3	20.84	20.78	20.81	24.16	24.10	24.13
		1	5	20.56	20.68	20.72	23.88	24.00	24.04
		3	0	19.65	19.89	19.90	22.97	23.21	23.22
		3	1	19.57	19.75	19.85	22.89	23.07	23.17
		3	3	19.58	19.60	19.53	22.90	22.92	22.85
		6	0	19.54	19.58	19.70	22.86	22.90	23.02
BW	Modulation	RB size	RB offset	Channel/Frequency(MHz)					
				131987/ 1711.5	132322/ 1745	132657/ 1778.5	131987/ 1711.5	132322/ 1745	132657/ 1778.5
3MHz	QPSK	1	0	22.68	22.77	22.68	26.00	26.09	26.00
		1	8	22.59	22.71	22.59	25.91	26.03	25.91
		1	14	22.60	22.63	22.75	25.92	25.95	26.07
		8	0	21.65	21.77	21.78	24.97	25.09	25.10

		8	4	21.75	21.79	21.71	25.07	25.11	25.03	
		8	7	21.57	21.64	21.46	24.89	24.96	24.78	
		15	0	21.74	21.60	21.63	25.06	24.92	24.95	
	16QAM	1	0	21.77	21.86	21.84	25.09	25.18	25.16	
		1	8	21.87	21.83	21.69	25.19	25.15	25.01	
		1	14	21.68	21.82	21.77	25.00	25.14	25.09	
		8	0	20.68	20.71	20.90	24.00	24.03	24.22	
		8	4	20.69	20.72	20.88	24.01	24.04	24.20	
		8	7	20.62	20.57	20.70	23.94	23.89	24.02	
		15	0	20.65	20.80	20.53	23.97	24.12	23.85	
	64QAM	1	0	20.73	20.87	20.81	24.05	24.19	24.13	
		1	8	20.82	20.82	20.82	24.14	24.14	24.14	
		1	14	20.58	20.69	20.73	23.90	24.01	24.05	
		8	0	19.69	19.81	19.83	23.01	23.13	23.15	
		8	4	19.62	19.66	19.62	22.94	22.98	22.94	
		8	7	19.61	19.70	19.56	22.93	23.02	22.88	
		15	0	19.64	19.75	19.87	22.96	23.07	23.19	
	BW	Modulation	RB size	RB offset	Channel/Frequency(MHz)					
					131997/ 1712.5	132322/ 1745	132647/ 1777.5	131997/ 1712.5	132322/ 1745	132647/ 1777.5
	5MHz	QPSK	1	0	22.66	22.78	22.73	25.98	26.10	26.05
			1	12	22.77	22.71	22.71	26.09	26.03	26.03
1			24	22.71	22.76	22.50	26.03	26.08	25.82	
12			0	21.72	21.76	21.76	25.04	25.08	25.08	
12			7	21.80	21.63	21.58	25.12	24.95	24.90	
12			13	21.60	21.62	21.51	24.92	24.94	24.83	
25			0	21.64	21.65	21.79	24.96	24.97	25.11	
16QAM		1	0	21.88	21.86	21.73	25.20	25.18	25.05	
		1	12	21.83	21.75	21.72	25.15	25.07	25.04	
		1	24	21.59	21.77	21.66	24.91	25.09	24.98	
		12	0	20.71	20.69	20.76	24.03	24.01	24.08	
		12	7	20.64	20.75	20.81	23.96	24.07	24.13	
		12	13	20.51	20.57	20.54	23.83	23.89	23.86	
		25	0	20.40	20.60	20.65	23.72	23.92	23.97	
64QAM		1	0	20.68	20.79	20.72	24.00	24.11	24.04	
		1	12	20.89	20.84	20.82	24.21	24.16	24.14	
		1	24	20.52	20.63	20.73	23.84	23.95	24.05	

BW	Modulation	RB size	RB offset	Channel/Frequency(MHz)						
				132022/ 1715	132322/ 1745	132622/ 1775	132022/ 1715	132322/ 1745	132622/ 1775	
				12	0	19.83	19.70	19.77	23.15	23.02
		12	7	19.66	19.80	19.78	22.98	23.12	23.10	
		12	13	19.59	19.75	19.78	22.91	23.07	23.10	
		25	0	19.56	19.70	19.65	22.88	23.02	22.97	
10MHz	QPSK	1	0	22.74	22.79	22.75	26.06	26.11	26.07	
		1	25	22.61	22.69	22.59	25.93	26.01	25.91	
		1	49	22.62	22.75	22.53	25.94	26.07	25.85	
		25	0	21.62	21.89	21.74	24.94	25.21	25.06	
		25	12	21.82	21.87	21.85	25.14	25.19	25.17	
		25	25	21.66	21.61	21.66	24.98	24.93	24.98	
		50	0	21.69	21.91	21.61	25.01	25.23	24.93	
	16QAM	1	0	21.76	21.80	21.82	25.08	25.12	25.14	
		1	25	21.83	21.76	21.75	25.15	25.08	25.07	
		1	49	21.68	21.69	21.83	25.00	25.01	25.15	
		25	0	20.82	20.88	20.86	24.14	24.20	24.18	
		25	12	20.65	20.86	20.62	23.97	24.18	23.94	
		25	25	20.59	20.53	20.67	23.91	23.85	23.99	
		50	0	20.69	20.77	20.60	24.01	24.09	23.92	
	64QAM	1	0	20.76	20.88	20.85	24.08	24.20	24.17	
		1	25	20.62	20.67	20.75	23.94	23.99	24.07	
		1	49	20.57	20.71	20.76	23.89	24.03	24.08	
		25	0	19.52	19.77	19.63	22.84	23.09	22.95	
		25	12	19.65	19.73	19.77	22.97	23.05	23.09	
		25	25	19.59	19.75	19.54	22.91	23.07	22.86	
		50	0	19.69	19.80	19.54	23.01	23.12	22.86	
	BW	Modulation	RB size	RB offset	Channel/Frequency(MHz)					
					132047/ 1717.5	132322/ 1745	132597/ 1772.5	132047/ 1717.5	132322/ 1745	132597/ 1772.5
	15MHz	QPSK	1	0	22.73	22.75	22.68	26.05	26.07	26.00
			1	37	22.72	22.68	22.70	26.04	26.00	26.02
			1	74	22.63	22.66	22.66	25.95	25.98	25.98
			36	0	21.76	21.87	21.86	25.08	25.19	25.18
			36	20	21.63	21.70	21.62	24.95	25.02	24.94
36			39	21.59	21.75	21.65	24.91	25.07	24.97	

BW	Modulation	RB size	RB offset	Channel/Frequency(MHz)					
				132047/ 1717.5	132322/ 1745	132597/ 1772.5	132047/ 1717.5	132322/ 1745	132597/ 1772.5
	16QAM	75	0	21.50	21.59	21.70	24.82	24.91	25.02
		1	0	21.75	21.85	21.85	25.07	25.17	25.17
		1	37	21.70	21.80	21.76	25.02	25.12	25.08
		1	74	21.82	21.86	21.78	25.14	25.18	25.10
		36	0	20.71	20.83	20.73	24.03	24.15	24.05
		36	20	20.66	20.80	20.95	23.98	24.12	24.27
		36	39	20.63	20.67	20.87	23.95	23.99	24.19
	75	0	20.67	20.65	20.51	23.99	23.97	23.83	
	64QAM	1	0	20.73	20.83	20.74	24.05	24.15	24.06
		1	37	20.64	20.74	20.61	23.96	24.06	23.93
		1	74	20.77	20.81	20.83	24.09	24.13	24.15
		36	0	19.65	19.75	19.82	22.97	23.07	23.14
		36	20	19.73	19.76	19.56	23.05	23.08	22.88
		36	39	19.58	19.84	19.69	22.90	23.16	23.01
75		0	19.51	19.71	19.84	22.83	23.03	23.16	
20MHz	QPSK	1	0	22.72	22.81	22.78	26.04	26.13	26.10
		1	37	22.74	22.67	22.59	26.06	25.99	25.91
		1	74	22.51	22.69	22.62	25.83	26.01	25.94
		36	0	21.79	21.90	21.88	25.11	25.22	25.20
		36	20	21.74	21.69	21.56	25.06	25.01	24.88
		36	39	21.66	21.71	21.68	24.98	25.03	25.00
		75	0	21.55	21.79	21.68	24.87	25.11	25.00
	16QAM	1	0	21.73	21.85	21.83	25.05	25.17	25.15
		1	37	21.56	21.71	21.76	24.88	25.03	25.08
		1	74	21.69	21.66	21.71	25.01	24.98	25.03
		36	0	20.81	20.86	20.72	24.13	24.18	24.04
		36	20	20.81	20.62	20.84	24.13	23.94	24.16
		36	39	20.52	20.76	20.60	23.84	24.08	23.92
		75	0	20.72	20.58	20.76	24.04	23.90	24.08
	64QAM	1	0	20.82	20.80	20.74	24.14	24.12	24.06
		1	37	20.70	20.76	20.70	24.02	24.08	24.02
		1	74	20.56	20.65	20.67	23.88	23.97	23.99
		36	0	19.73	19.84	19.71	23.05	23.16	23.03
		36	20	19.63	19.56	19.76	22.95	22.88	23.08

		36	39	19.57	19.60	19.79	22.89	22.92	23.11
		75	0	19.77	19.69	19.73	23.09	23.01	23.05

LTE CA_41C Combination:20MHz+20MHz(100RB+100RB)									
PCC	SCC	Modulation	PCC		SCC		Total RB Size	Measured Power(dBm)	EIRP (dBm)
Channel	Channel		RB Size	RB Offset	RB Size	RB Offset			
39750	39948	QPSK	1	0	0	0	1	24.60	28.67
40521	40719	QPSK	1	0	0	0	1	24.63	28.70
41292	41490	QPSK	1	0	0	0	1	24.59	28.66

6.2 Radiated Spurious Emission

Sweep the whole frequency band through the range from 9kHz to the 10th harmonic of the carrier, the emissions below the noise floor will not be recorded in the report.

LTE Band 4 QPSK 1.4MHz CH-Middle, RB 1

Harmonic	Frequency (MHz)	SG (dBm)	Cable Loss (dB)	Gain (dBi)	Antenna Polarization	EIRP Level (dBm)	Limit (dBm)	Margin (dB)	Azimuth (deg)
2	3464.50	-77.34	2.70	12.70	Vertical	-67.34	-13.00	54.34	29
3	5194.70	-74.24	3.20	12.50	Vertical	-64.94	-13.00	51.94	167
4	6923.60	-70.63	4.20	11.80	Vertical	-63.03	-13.00	50.03	22
5	8663.20	-64.93	4.40	12.50	Vertical	-56.83	-13.00	43.83	147
6	10387.80	-63.76	4.70	11.30	Vertical	-57.16	-13.00	44.16	158
7	12131.00	-65.67	5.20	13.80	Vertical	-57.07	-13.00	44.07	82
8	13849.00	-60.88	5.70	11.30	Vertical	-55.28	-13.00	42.28	24
9	15587.00	-71.72	6.10	16.80	Vertical	-61.02	-13.00	48.02	157
10	17319.40	-63.42	6.10	14.20	Vertical	-55.32	-13.00	42.32	36

Note: 1. The other Spurious RF Radiated emissions level is no more than noise floor.
2. The worst emission was found in the antenna is Vertical position.

LTE Band 4 QPSK 5MHz CH-Middle, RB 1

Harmonic	Frequency (MHz)	SG (dBm)	Cable Loss (dB)	Gain (dBi)	Antenna Polarization	EIRP Level (dBm)	Limit (dBm)	Margin (dB)	Azimuth (deg)
2	3460.70	-76.50	2.70	12.70	Vertical	-66.50	-13.00	53.50	25
3	5185.90	-74.09	3.20	12.50	Vertical	-64.79	-13.00	51.79	257
4	6924.40	-70.29	4.20	11.80	Vertical	-62.69	-13.00	49.69	39
5	8653.80	-65.11	4.40	12.50	Vertical	-57.01	-13.00	44.01	67
6	10379.20	-63.88	4.70	11.30	Vertical	-57.28	-13.00	44.28	138
7	12109.80	-66.84	5.20	13.80	Vertical	-58.24	-13.00	45.24	24
8	13844.00	-59.41	5.70	11.30	Vertical	-53.81	-13.00	40.81	221
9	15576.20	-70.91	6.10	16.80	Vertical	-60.21	-13.00	47.21	72
10	17315.40	-62.61	6.10	14.20	Vertical	-54.51	-13.00	41.51	85

Note: 1. The other Spurious RF Radiated emissions level is no more than noise floor.
2. The worst emission was found in the antenna is Vertical position.

LTE Band 4 QPSK 20MHz CH-Middle, RB 1

Harmonic	Frequency (MHz)	SG (dBm)	Cable Loss (dB)	Gain (dBi)	Antenna Polarization	EIRP Level (dBm)	Limit (dBm)	Margin (dB)	Azimuth (deg)
2	3747.40	-75.89	2.70	12.70	Vertical	-65.89	-13.00	52.89	62
3	5162.90	-73.42	3.20	12.50	Vertical	-64.12	-13.00	51.12	129
4	6886.20	-70.57	4.20	11.80	Vertical	-62.97	-13.00	49.97	32
5	8611.80	-64.76	4.40	12.50	Vertical	-56.66	-13.00	43.66	223
6	10338.80	-63.60	4.70	11.30	Vertical	-57.00	-13.00	44.00	28
7	12055.00	-66.90	5.20	13.80	Vertical	-58.30	-13.00	45.30	164
8	13776.80	-60.62	5.70	11.30	Vertical	-55.02	-13.00	42.02	37
9	15505.00	-71.00	6.10	16.80	Vertical	-60.30	-13.00	47.30	248
10	17222.20	-62.63	6.10	14.20	Vertical	-54.53	-13.00	41.53	149

Note: 1.The other Spurious RF Radiated emissions level is no more than noise floor.
2. The worst emission was found in the antenna is Vertical position.

LTE Band 12 QPSK 1.4MHz CH-Middle, RB 1

Harmonic	Frequency (MHz)	SG (dBm)	Cable Loss (dB)	Gain (dBi)	Antenna Polarization	ERP Level (dBm)	Limit (dBm)	Margin (dB)	Azimuth (deg)
2	1412.40	-68.70	1.70	8.70	Vertical	-63.85	-13.00	50.85	86
3	2120.13	-66.96	2.10	11.10	Vertical	-60.11	-13.00	47.11	27
4	2825.87	-66.47	2.30	13.10	Vertical	-57.82	-13.00	44.82	139
5	3535.67	-65.10	2.60	12.70	Vertical	-57.15	-13.00	44.15	146
6	4240.80	-62.90	3.30	12.50	Vertical	-55.85	-13.00	42.85	35
7	4955.00	-62.49	3.40	12.50	Vertical	-55.54	-13.00	42.54	62
8	5652.67	-62.94	3.30	12.50	Vertical	-55.89	-13.00	42.89	147
9	6364.00	-58.81	3.80	11.50	Vertical	-53.26	-13.00	40.26	18
10	7066.83	-57.42	4.20	11.80	Vertical	-51.97	-13.00	38.97	24

Note: 1.The other Spurious RF Radiated emissions level is no more than noise floor.
2. The worst emission was found in the antenna is Vertical position.

LTE Band 12 QPSK 5MHz CH-Middle, RB 1

Harmonic	Frequency (MHz)	SG (dBm)	Cable Loss (dB)	Gain (dBi)	Antenna Polarization	ERP Level (dBm)	Limit (dBm)	Margin (dB)	Azimuth (deg)
2	1412.27	-68.01	1.70	8.70	Vertical	-63.16	-13.00	50.16	23
3	2115.80	-67.17	2.10	11.10	Vertical	-60.32	-13.00	47.32	243
4	2819.93	-66.62	2.30	13.10	Vertical	-57.97	-13.00	44.97	16
5	3527.67	-64.34	2.60	12.70	Vertical	-56.39	-13.00	43.39	85
6	4234.67	-63.68	3.30	12.50	Vertical	-56.63	-13.00	43.63	149
7	4930.50	-62.15	3.40	12.50	Vertical	-55.20	-13.00	42.20	28
8	5640.50	-63.07	3.30	12.50	Vertical	-56.02	-13.00	43.02	92
9	6343.00	-58.83	3.80	11.50	Vertical	-53.28	-13.00	40.28	61
10	7049.66	-57.73	4.20	11.80	Vertical	-52.28	-13.00	39.28	23

Note: 1. The other Spurious RF Radiated emissions level is no more than noise floor.
 2. The worst emission was found in the antenna is Vertical position.

LTE Band 12 QPSK 10MHz CH-Middle, RB 1

Harmonic	Frequency (MHz)	SG (dBm)	Cable Loss (dB)	Gain (dBi)	Antenna Polarization	ERP Level (dBm)	Limit (dBm)	Margin (dB)	Azimuth (deg)
2	1406.20	-67.89	1.70	8.70	Vertical	-63.04	-13.00	50.04	136
3	2107.20	-67.27	2.10	11.10	Vertical	-60.42	-13.00	47.42	25
4	2809.53	-66.25	2.30	13.10	Vertical	-57.60	-13.00	44.60	247
5	3512.50	-65.02	2.60	12.70	Vertical	-57.07	-13.00	44.07	245
6	4215.00	-63.12	3.30	12.50	Vertical	-56.07	-13.00	43.07	15
7	4917.50	-63.46	3.40	12.50	Vertical	-56.51	-13.00	43.51	36
8	5620.00	-63.40	3.30	12.50	Vertical	-56.35	-13.00	43.35	17
9	6322.50	-60.25	3.80	11.50	Vertical	-54.70	-13.00	41.70	25
10	7025.00	-57.99	4.20	11.80	Vertical	-52.54	-13.00	39.54	168

Note: 1. The other Spurious RF Radiated emissions level is no more than noise floor.
 2. The worst emission was found in the antenna is Vertical position.

LTE Band 41 QPSK 5MHz CH-Middle, RB 1

Harmonic	Frequency (MHz)	SG (dBm)	Cable Loss (dB)	Gain (dBi)	Antenna Polarization	EIRP Level (dBm)	Limit (dBm)	Margin (dB)	Azimuth (deg)
2	5181.00	-65.16	3.20	12.50	Vertical	-55.86	-25.00	30.86	74
3	7771.50	-57.73	4.40	12.30	Vertical	-49.83	-25.00	24.83	23
4	10362.00	-53.74	4.70	11.80	Vertical	-46.64	-25.00	21.64	1
5	13952.50	-52.38	5.40	14.00	Vertical	-43.78	-25.00	18.78	153
6	15543.00	-61.28	6.10	16.80	Vertical	-50.58	-25.00	25.58	225
7	18133.50	--	--	--	--	--	--	--	--
8	20653.20	--	--	--	--	--	--	--	--
9	23234.85	--	--	--	--	--	--	--	--
10	25816.50	--	--	--	--	--	--	--	--

Note: 1.The other Spurious RF Radiated emissions level is no more than noise floor.
 2. The worst emission was found in the antenna is Vertical position.

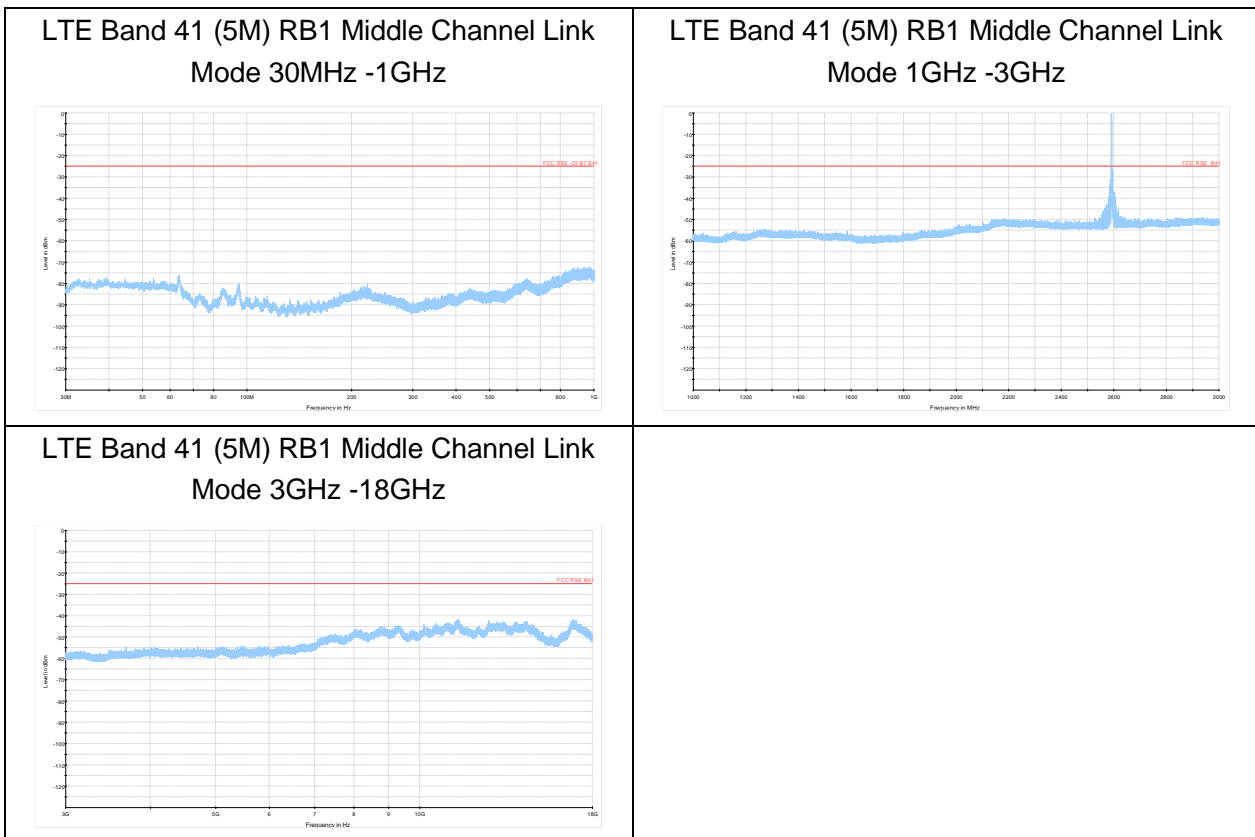

The signal beyond the limit is carrier.

LTE Band 41 QPSK 20MHz CH-Middle, RB 1

Harmonic	Frequency (MHz)	SG (dBm)	Cable Loss (dB)	Gain (dBi)	Antenna Polarization	EIRP Level (dBm)	Limit (dBm)	Margin (dB)	Azimuth (deg)
2	5166.00	-64.54	3.20	12.50	Vertical	-55.24	-25.00	30.24	58
3	7749.00	-57.54	4.40	12.30	Vertical	-49.64	-25.00	24.64	175
4	10332.00	-54.21	4.70	11.80	Vertical	-47.11	-25.00	22.11	86
5	12915.00	-52.63	5.40	14.00	Vertical	-44.03	-25.00	19.03	156
6	15498.00	--	--	--	--	--	--	--	--
7	18023.60	--	--	--	--	--	--	--	--
8	20598.40	--	--	--	--	--	--	--	--
9	23173.20	--	--	--	--	--	--	--	--
10	25748.00	--	--	--	--	--	--	--	--

Note: 1.The other Spurious RF Radiated emissions level is no more than noise floor.
 2. The worst emission was found in the antenna is Vertical position.

LTE Band 66 QPSK 1.4MHz CH-Middle, RB 1

Harmonic	Frequency (MHz)	SG (dBm)	Cable Loss (dB)	Gain (dBi)	Antenna Polarization	EIRP Level (dBm)	Limit (dBm)	Margin (dB)	Azimuth (deg)
2	3509.25	-77.23	2.70	12.70	Vertical	-67.23	-13.00	54.23	36
3	5262.50	-75.18	3.20	12.50	Vertical	-65.88	-13.00	52.88	2
4	7018.00	-70.40	4.20	11.80	Vertical	-62.80	-13.00	49.80	175
5	8772.50	-64.60	4.40	12.50	Vertical	-56.50	-13.00	43.50	63
6	10527.00	-62.88	4.70	11.80	Vertical	-55.78	-13.00	42.78	23
7	12281.50	-65.26	5.20	13.80	Vertical	-56.66	-13.00	43.66	123
8	14036.00	-61.94	5.70	13.20	Vertical	-54.44	-13.00	41.44	38
9	15790.50	-71.47	6.10	16.80	Vertical	-60.77	-13.00	47.77	26
10	17545.00	-64.39	6.10	14.20	Vertical	-56.29	-13.00	43.29	176

Note: 1. The other Spurious RF Radiated emissions level is no more than noise floor.
 2. The worst emission was found in the antenna is Vertical position.

LTE Band 66 QPSK 5MHz CH-Middle, RB 1

Harmonic	Frequency (MHz)	SG (dBm)	Cable Loss (dB)	Gain (dBi)	Antenna Polarization	EIRP Level (dBm)	Limit (dBm)	Margin (dB)	Azimuth (deg)
2	3486.00	-77.57	2.70	12.70	Vertical	-67.57	-13.00	54.57	35
3	5229.00	-75.33	3.20	12.50	Vertical	-66.03	-13.00	53.03	93
4	6972.00	-71.08	4.20	11.80	Vertical	-63.48	-13.00	50.48	178
5	8715.00	-64.72	4.40	12.50	Vertical	-56.62	-13.00	43.62	253
6	10458.00	-64.00	4.70	11.80	Vertical	-56.90	-13.00	43.90	24
7	12201.00	-64.78	5.20	13.80	Vertical	-56.18	-13.00	43.18	175
8	13944.00	-62.50	5.70	13.20	Vertical	-55.00	-13.00	42.00	2
9	15687.00	-71.15	6.10	16.80	Vertical	-60.45	-13.00	47.45	36
10	17430.00	-63.74	6.10	14.20	Vertical	-55.64	-13.00	42.64	75

Note: 1. The other Spurious RF Radiated emissions level is no more than noise floor.
 2. The worst emission was found in the antenna is Vertical position.

LTE Band 66 QPSK 20MHz CH-Middle, RB 1

Harmonic	Frequency (MHz)	SG (dBm)	Cable Loss (dB)	Gain (dBi)	Antenna Polarization	EIRP Level (dBm)	Limit (dBm)	Margin (dB)	Azimuth (deg)
2	3472.88	-76.11	2.70	12.70	Vertical	-66.11	-13.00	53.11	22
3	5209.00	-75.30	3.20	12.50	Vertical	-66.00	-13.00	53.00	15
4	6945.75	-71.09	4.20	11.80	Vertical	-63.49	-13.00	50.49	27
5	8682.00	-64.66	4.40	12.50	Vertical	-56.56	-13.00	43.56	301
6	10418.63	-63.42	4.70	11.80	Vertical	-56.32	-13.00	43.32	96
7	12455.00	-65.10	5.20	13.80	Vertical	-56.50	-13.00	43.50	285
8	13891.50	-62.30	5.70	13.20	Vertical	-54.80	-13.00	41.80	17
9	15627.00	-70.77	6.10	16.80	Vertical	-60.07	-13.00	47.07	22
10	17364.38	-63.58	6.10	14.20	Vertical	-55.48	-13.00	42.48	142

Note: 1. The other Spurious RF Radiated emissions level is no more than noise floor.
 2. The worst emission was found in the antenna is Vertical position.

CA_41C QPSK 5M+20M CH-Middle, RB 1

Harmonic	Frequency (MHz)	SG (dBm)	Cable Loss (dB)	Gain (dBi)	Antenna Polarization	EIRP Level (dBm)	Limit (dBm)	Margin (dB)	Azimuth (deg)
2	5163.00	-64.37	3.20	12.50	Horizontal	-55.07	-25.00	30.07	175
3	7743.90	-57.52	4.40	12.30	Horizontal	-49.62	-25.00	24.62	56
4	10325.20	-53.17	4.70	11.80	Horizontal	-46.07	-25.00	21.07	135
5	12906.50	-53.22	5.40	14.00	Horizontal	-44.62	-25.00	19.62	48
6	15487.80	-61.32	6.10	16.80	Horizontal	-50.62	-25.00	25.62	27
7	18069.10	--	--	--	--	--	--	--	--
8	20684.00	--	--	--	--	--	--	--	--
9	23269.50	--	--	--	--	--	--	--	--
10	25855.00	--	--	--	--	--	--	--	--

Note: 1. The other Spurious RF Radiated emissions level is no more than noise floor.
 2. The worst emission was found in the antenna is Horizontal position.

CA_41C QPSK 20M+5M CH-Middle, RB 1

Harmonic	Frequency (MHz)	SG (dBm)	Cable Loss (dB)	Gain (dBi)	Antenna Polarization	EIRP Level (dBm)	Limit (dBm)	Margin (dB)	Azimuth (deg)
2	5176.00	-64.69	3.20	12.50	Horizontal	-55.39	-25.00	30.39	63
3	7764.00	-56.80	4.40	12.30	Horizontal	-48.90	-25.00	23.90	96
4	10352.00	-53.29	4.70	11.80	Horizontal	-46.19	-25.00	21.19	186
5	12940.00	-52.84	5.40	14.00	Horizontal	-44.24	-25.00	19.24	25
6	15528.00	-60.64	6.10	16.80	Horizontal	-49.94	-25.00	24.94	154
7	18116.00	--	--	--	--	--	--	--	--
8	20704.00	--	--	--	--	--	--	--	--
9	23292.00	--	--	--	--	--	--	--	--
10	25880.00	--	--	--	--	--	--	--	--

Note: 1. The other Spurious RF Radiated emissions level is no more than noise floor.
 2. The worst emission was found in the antenna is Horizontal position.

CA_41C QPSK 15M+15M CH-Middle, RB 1

Harmonic	Frequency (MHz)	SG (dBm)	Cable Loss (dB)	Gain (dBi)	Antenna Polarization	EIRP Level (dBm)	Limit (dBm)	Margin (dB)	Azimuth (deg)
2	5156.00	-64.63	3.20	12.50	Horizontal	-55.33	-25.00	30.33	259
3	7734.00	-58.34	4.40	12.30	Horizontal	-50.44	-25.00	25.44	157
4	10262.00	-53.12	4.70	11.80	Horizontal	-46.02	-25.00	21.02	63
5	12890.00	-53.03	5.40	14.00	Horizontal	-44.43	-25.00	21.02	98
6	15468.00	-60.98	6.10	16.80	Horizontal	-50.28	-25.00	25.28	48
7	18046.00	--	--	--	--	--	--	--	--
8	20624.00	--	--	--	--	--	--	--	--
9	23202.00	--	--	--	--	--	--	--	--
10	25780.00	--	--	--	--	--	--	--	--

Note: 1. The other Spurious RF Radiated emissions level is no more than noise floor.
 2. The worst emission was found in the antenna is Horizontal position.

CA_41C QPSK 20M+20M CH-Middle, RB 1

Harmonic	Frequency (MHz)	SG (dBm)	Cable Loss (dB)	Gain (dBi)	Antenna Polarization	EIRP Level (dBm)	Limit (dBm)	Margin (dB)	Azimuth (deg)
2	5146.20	-64.14	3.20	12.50	Horizontal	-54.84	-25.00	29.84	274
3	7719.30	-57.19	4.40	12.30	Horizontal	-49.29	-25.00	24.29	28
4	10292.40	-53.61	4.70	11.80	Horizontal	-46.51	-25.00	21.51	93
5	12865.50	-53.06	5.40	14.00	Horizontal	-44.46	-25.00	19.46	185
6	15438.60	-61.18	6.10	16.80	Horizontal	-50.48	-25.00	25.48	21
7	18011.70	--	--	--	--	--	--	--	--
8	20584.80	--	--	--	--	--	--	--	--
9	23157.90	--	--	--	--	--	--	--	--
10	25731.00	--	--	--	--	--	--	--	--

Note: 1. The other Spurious RF Radiated emissions level is no more than noise floor.
 2. The worst emission was found in the antenna is Horizontal position.

7 Main Test Instruments

Name	Manufacturer	Type	Serial Number	Calibration Date	Expiration Date
Spectrum Analyzer	R&S	FSV30	100815	2023-12-05	2024-12-04
Loop Antenna	SCHWARZBECK	FMZB1519	1519-047	2023-04-16	2026-04-15
TRILOG Broadband Antenna	SCHWARZBECK	VULB 9163	391	2022-09-29	2025-09-28
Horn Antenna	SCHWARZBECK	BBHA 9120D	1594	2023-12-05	2026-12-04
Software	R&S	EMC32	10.35.10	/	/

ANNEX A: The EUT Appearance

The EUT Appearance are submitted separately.

ANNEX B: Test Setup Photos

The Test Setup Photos are submitted separately.

ANNEX C: Product Change Description

The Product Change Description are submitted separately.

***** END OF REPORT *****