



TEST REPORT

Test report no.: 1-1894/21-01-14-A

BNetzA-CAB-02/21-102

Testing laboratory

CTC advanced GmbH
Untertuerkheimer Strasse 6 – 10
66117 Saarbruecken / Germany
Phone: + 49 681 5 98 - 0
Fax: + 49 681 5 98 - 9075
Internet: <https://www.ctcadvanced.com>
e-mail: mail@ctcadvanced.com

Accredited Testing Laboratory:

The testing laboratory (area of testing) is accredited according to DIN EN ISO/IEC 17025 (2018-03) by the Deutsche Akkreditierungsstelle GmbH (DAkkS). The accreditation is valid for the scope of testing procedures as stated in the accreditation certificate starting with the registration number: D-PL-12076-01.

Applicant

Trackunit Aps
Gasvaerksvej 24, 4sal
9000 Aalborg / DENMARK
Phone: +45 96 73 74 00
Contact: Martin Bang
e-mail: mb@trackunit.com

Manufacturer

Trackunit Aps
Gasvaerksvej 24, 4sal
9000 Aalborg / DENMARK

Test standard/s

FCC - Title 47 CFR Part 22 FCC - Title 47 of the Code of Federal Regulations; Chapter I; Part 22 - Public mobile services
FCC - Title 47 CFR Part 24 FCC - Title 47 of the Code of Federal Regulations; Chapter I; Part 24 - Personal communications services

For further applied test standards please refer to section 3 of this test report.

Test Item

Kind of test item: **Telematic unit for Fleet management**
Model name: **TU600-15 (Family TU600A)**
FCC ID: **ZMF-TU600A**
IC: **9746A-TU600A**
Frequency: LTE bands 2, 4, 5, 12, 13, 25, 26, 66, 71, 85
Technology tested: LTE Cat M1 / LTE Cat NB2
Antenna: Integrated antenna
Power supply: 12V-48V DC external power supply or 3.7V DC by internal backup battery
Temperature range: -30°C to +55°C (+60°C with internal battery power)

This test report is electronically signed and valid without handwritten signature. For verification of the electronic signatures, the public keys can be requested at the testing laboratory.

Test report authorized:

Michael Dorongovski
Lab Manager
Radio Communications

Test performed:

Andreas Luckenbill
Head of Department
Radio Communications

1 Table of contents

1	Table of contents	2
2	General information	4
2.1	Notes and disclaimer	4
2.2	Application details	4
2.3	Test laboratories sub-contracted	4
3	Test standard/s, references and accreditations	5
4	Reporting statements of conformity – decision rule	6
5	Test environment.....	7
6	Test item	7
6.1	General description	7
6.2	Additional information	7
7	Description of the test setup.....	8
7.1	Shielded semi anechoic chamber	9
7.2	Shielded fully anechoic chamber.....	10
7.3	Radiated measurements > 18 GHz	12
8	Sequence of testing.....	13
8.1	Sequence of testing radiated spurious 9 kHz to 30 MHz	13
8.2	Sequence of testing radiated spurious 30 MHz to 1 GHz.....	14
8.3	Sequence of testing radiated spurious 1 GHz to 18 GHz.....	15
8.4	Sequence of testing radiated spurious above 18 GHz.....	16
9	Measurement uncertainty	17
10	Summary of measurement results LTE band 2; LTE band 25	18
10.1	LTE – Band 2	18
10.2	LTE – Band 25	19
11	RF measurements LTE band 2	20
11.1	Description of test setup.....	20
11.2	Results	20
11.2.1	RF output power	20
11.2.2	Spurious emissions radiated.....	22
12	RF measurements LTE band 25.....	28
12.1	Description of test setup.....	28
12.2	Results	28
12.2.1	RF output power	28
12.2.2	Spurious emissions radiated.....	30
13	Summary of measurement results LTE band 5; LTE band 26	36
13.1	LTE – Band 5	36
13.2	LTE – Band 26	37
14	RF measurements LTE band 5	38
14.1	Description of test setup.....	38

14.2	Results	38
14.2.1	RF output power	38
14.2.2	Spurious emissions radiated.....	40
15	RF measurements LTE band 26.....	46
15.1	Description of test setup.....	46
15.2	Results	46
15.2.1	RF output power	46
15.2.2	Spurious emissions radiated.....	48
16	Summary of measurement results LTE band 4, 12, 13, 66, 71 & 85	52
16.1	LTE – Band 4	52
16.2	LTE – Band 12	53
16.3	LTE – Band 13	53
16.4	LTE – Band 66	54
16.5	LTE – Band 71	54
16.6	LTE – Band 85	55
17	RF measurements.....	56
17.1	Description of test setup.....	56
17.2	Results LTE – Band 4	56
17.2.1	RF output power	56
17.2.2	Spurious emissions radiated.....	58
17.3	Results LTE – Band 12	64
17.3.1	RF output power	64
17.3.2	Spurious emissions radiated.....	66
17.4	Results LTE – Band 13	72
17.4.1	RF output power	72
17.4.2	Spurious emissions radiated.....	74
17.5	Results LTE – Band 66	80
17.5.1	RF output power	80
17.5.2	Spurious emissions radiated.....	82
17.6	Results LTE – Band 71	88
17.6.1	RF output power	88
17.6.2	Spurious emissions radiated.....	90
17.7	Results LTE – Band 85	94
17.7.1	RF output power	94
17.7.2	Spurious emissions radiated.....	96
18	Glossary.....	102
19	Document history.....	103
20	Accreditation Certificate – D-PL-12076-01-04	103
21	Accreditation Certificate – D-PL-12076-01-05	105

2 General information

2.1 Notes and disclaimer

The test results of this test report relate exclusively to the test item specified in this test report. CTC advanced GmbH does not assume responsibility for any conclusions and generalizations drawn from the test results with regard to other specimens or samples of the type of the equipment represented by the test item.

The test report may only be reproduced or published in full. Reproduction or publication of extracts from the report requires the prior written approval of CTC advanced GmbH.

The testing service provided by CTC advanced GmbH has been rendered under the current "General Terms and Conditions for CTC advanced GmbH".

CTC advanced GmbH will not be liable for any loss or damage resulting from false, inaccurate, inappropriate or incomplete product information provided by the customer.

Under no circumstances does the CTC advanced GmbH test report include any endorsement or warranty regarding the functionality, quality or performance of any other product or service provided.

Under no circumstances does the CTC advanced GmbH test report include or imply any product or service warranties from CTC advanced GmbH, including, without limitation, any implied warranties of merchantability, fitness for purpose, or non-infringement, all of which are expressly disclaimed by CTC advanced GmbH.

All rights and remedies regarding vendor's products and services for which CTC advanced GmbH has prepared this test report shall be provided by the party offering such products or services and not by CTC advanced GmbH. In no case this test report can be considered as a Letter of Approval.

This test report is electronically signed and valid without handwritten signature. For verification of the electronic signatures, the public keys can be requested at the testing laboratory.

This test report replaces the test report with the number 1-1894/21-01-14 and dated 2021-07-30.

2.2 Application details

Date of receipt of order:	2021-03-04
Date of receipt of test item:	2021-03-04
Start of test:*	2021-03-08
End of test:*	2021-07-08
Person(s) present during the test:	-/-

*Date of each measurement, if not shown in the plot, can be requested. Dates are stored in the measurement software.





2.3 Test laboratories sub-contracted

None

3 Test standard/s, references and accreditations

Test standard	Date	Description
FCC - Title 47 CFR Part 22		FCC - Title 47 of the Code of Federal Regulations; Chapter I; Part 22 - Public mobile services
FCC - Title 47 CFR Part 24		FCC - Title 47 of the Code of Federal Regulations; Chapter I; Part 24 - Personal communications services
FCC - Title 47 CFR Part 27		FCC - Title 47 of the Code of Federal Regulations; Chapter I; Part 27 - Miscellaneous wireless communications services
RSS - 132 Issue 3	January 2013	Spectrum Management and Telecommunications Radio Standards Specification - Cellular Telephone Systems Operating in the Bands 824-849 MHz and 869-894 MHz
RSS - 133 Issue 6	January 2018	Spectrum Management and Telecommunications Policy - Radio Standards Specifications, 2 GHz Personal Communication Services
RSS - 139 Issue 3	July 2015	Advanced Wireless Services (AWS) Equipment Operating in the Bands 1710-1780 MHz and 2110-2180 MHz
RSS - 130 Issue 2	February 2019	Equipment Operating in the Frequency Bands 617-652 MHz, 663-698 MHz, 698-756 MHz and 777-787 MHz
RSS - 199 Issue 3	December 2016	Broadband Radio Service (BRS) Equipment Operating in the Band 2500-2690 MHz
FCC - Title 47 CFR Part 90		FCC - Title 47 of the Code of Federal Regulations; Chapter I; Part 90 - Private Land Mobile Radio Services

Guidance	Version	Description
ANSI C63.4-2014	-/-	American National Standard for Methods of Measurement of Radio-Noise Emissions from Low-Voltage Electrical and Electronic Equipment in the Range of 9 kHz to 40 GHz
ANSI C63.26-2015	-/-	American National Standard for Compliance Testing of Transmitters Used in Licensed Radio Services
Power Meas License Systems: KDB 971168 D01	v03r01	Measurement Guidance for Certification of Licensed Digital Transmitters

Accreditation	Description
D-PL-12076-01-04	Telecommunication and EMC Canada https://www.dakks.de/as/ast/d/D-PL-12076-01-04e.pdf   Deutsche Akkreditierungsstelle D-PL-12076-01-04
D-PL-12076-01-05	Telecommunication FCC requirements https://www.dakks.de/as/ast/d/D-PL-12076-01-05e.pdf   Deutsche Akkreditierungsstelle D-PL-12076-01-05

4 Reporting statements of conformity – decision rule

Only the measured values related to their corresponding limits will be used to decide whether the equipment under test meets the requirements of the test standards listed in chapter 3.

The measurement uncertainty is mentioned in this test report, see chapter 9, but is not taken into account - neither to the limits nor to the measurement results. Measurement results with a smaller margin to the corresponding limits than the measurement uncertainty have a potential risk of more than 5% that the decision might be wrong."

measured value, measurement uncertainty, verdict



5 Test environment

Temperature	T _{nom}	+22 °C during room temperature tests
	T _{max}	No tests under extreme environmental conditions performed.
	T _{min}	No tests under extreme environmental conditions performed.
Relative humidity content		55 %
Barometric pressure		1021 hpa
Power supply	V _{nom}	12.0 V DC by external power supply
	V _{max}	No tests under extreme environmental conditions performed.
	V _{min}	No tests under extreme environmental conditions performed.

6 Test item

6.1 General description

Kind of test item	Telematic unit for Fleet management	
Model name	TU600-15 (Family TU600A)	
HMN	-/-	
PMN	Trackunit	
HVIN	TU600-11 TU600-15	
FVIN	-/-	
S/N serial number	Rad.	Sample 13
Hardware status	1.001	
Software status	60.012	
Firmware status	N/A	
Frequency band	LTE bands 2, 4, 5, 12, 13, 25, 26, 66, 71, 85	
Type of radio transmission	OFDM	
Use of frequency spectrum		
Type of modulation	BPSK, QPSK, 16-QAM	
Antenna	Integrated antenna	
Power supply	12V-48V DC external power supply or 3.7V DC by internal backup battery	
Temperature range	-30°C to +55°C (+60°C with internal battery power)	

6.2 Additional information

The content of the following annexes is defined in the QA. It may be that not all of the listed annexes are necessary for this report, thus some values in between may be missing.

Test setup and EUT photos are included in test report:

- 1-1894/21-01-01_AnnexA
- 1-1894/21-01-01_AnnexB
- 1-1894/21-01-01_AnnexD

7 Description of the test setup

Typically, the calibrations of the test apparatus are commissioned to and performed by an accredited calibration laboratory. The calibration intervals are determined in accordance with the DIN EN ISO/IEC 17025. In addition to the external calibrations, the laboratory executes comparison measurements with other calibrated test systems or effective verifications. Weekly chamber inspections and range calibrations are performed. Where possible, RF generating and signaling equipment as well as measuring receivers and analyzers are connected to an external high-precision 10 MHz reference (GPS-based or rubidium frequency standard).

In order to simplify the identification of the equipment used at some special tests, some items of test equipment and ancillaries can be provided with an identifier or number in the equipment list below (Lab/Item).

Agenda: Kind of Calibration

k	calibration / calibrated	EK	limited calibration
ne	not required (k, ev, izw, zw not required)	zw	cyclical maintenance (external cyclical maintenance)
ev	periodic self verification	izw	internal cyclical maintenance
Ve	long-term stability recognized	g	blocked for accredited testing
vlk!	Attention: extended calibration interval		
NK!	Attention: not calibrated	*)	next calibration ordered / currently in progress

7.1 Shielded semi anechoic chamber

The radiated measurements are performed in vertical and horizontal plane in the frequency range from 30 MHz to 1 GHz in semi-anechoic chambers. The EUT is positioned on a non-conductive support with a height of 0.80 m above a conductive ground plane that covers the whole chamber. The receiving antennas are conform to specifications ANSI C63. These antennas can be moved over the height range between 1.0 m and 4.0 m in order to search for maximum field strength emitted from EUT. The measurement distances between EUT and receiving antennas are indicated in the test setups for the various frequency ranges. For each measurement, the EUT is rotated in all three axes until the maximum field strength is received. The wanted and unwanted emissions are received by spectrum analyzers where the detector modes and resolution bandwidths over various frequency ranges are set according to requirement ANSI C63.

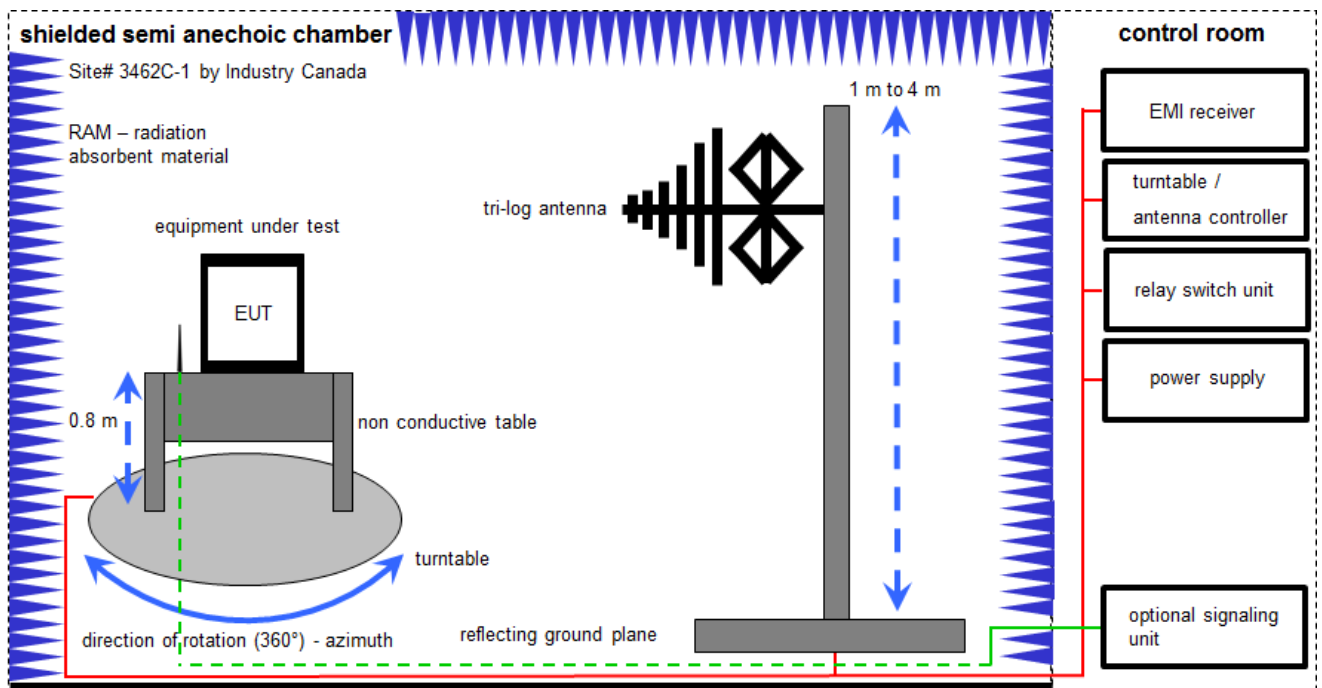

Measurement distance: tri-log antenna 10 meter; EMC32 software version: 10.30.0

$$FS = UR + CL + AF$$

(FS-field strength; UR-voltage at the receiver; CL-loss of the cable; AF-antenna factor)

Example calculation:

$$FS [dB\mu V/m] = 12.35 [dB\mu V/m] + 1.90 [dB] + 16.80 [dB/m] = 31.05 [dB\mu V/m] (35.69 \mu V/m)$$

Equipment table:

No.	Setup	Equipment	Type	Manufacturer	Serial No.	INV. No.	Kind of Calibration	Last Calibration	Next Calibration
1	A	Switch-Unit	3488A	HP	2719A14505	300000368	ev	-/-	-/-
2	A	DC power supply, 60Vdc, 50A, 1200 W	6032A	HP	2920A04466	300000580	ne	-/-	-/-
3	A	Semi anechoic chamber	3000023	MWB AG	-/-	300000551	ne	-/-	-/-
4	A	Antenna Tower	Model 2175	ETS-Lindgren	64762	300003745	izw	-/-	-/-
5	A	Positioning Controller	Model 2090	ETS-Lindgren	64672	300003746	izw	-/-	-/-
6	A	Turntable Interface-Box	Model 105637	ETS-Lindgren	44583	300003747	izw	-/-	-/-
7	A	TRILOG Broadband Test-Antenna 30 MHz - 3 GHz	VULB9163	Schwarzbeck Mess - Elektronik	318	300003696	vKI!	04.09.2019	03.09.2021
8	A	EMI Test Receiver	ESR3	Rohde & Schwarz	102587	300005771	k	10.12.2020	09.06.2022
9	A	Turntable	2089-4.0	EMCO	-/-	300004394	ne	-/-	-/-
10	A	PC	TecLine	F+W	-/-	300004388	ne	-/-	-/-
11	A	Wideband Radio Communication Tester	CMW500	R&S	102375	300004187	k	12.12.2019	11.12.2021

7.2 Shielded fully anechoic chamber

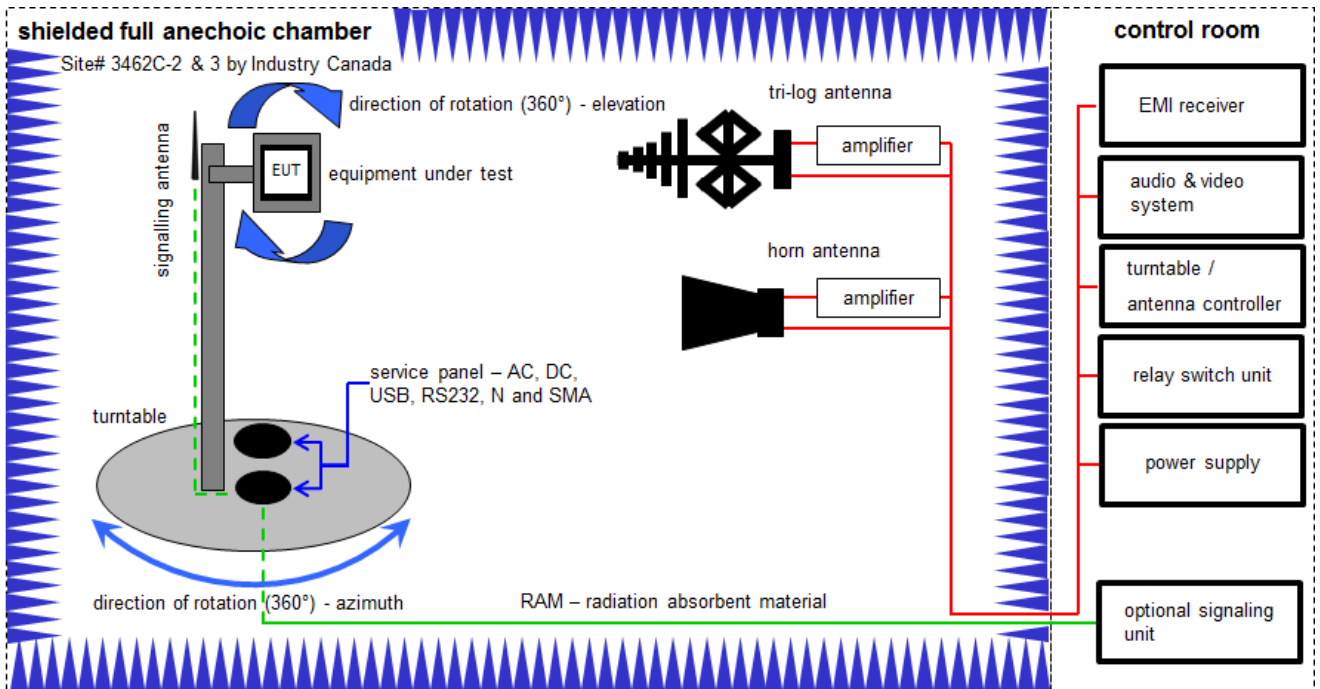

Measurement distance: tri-log antenna and horn antenna 3 meter

OP = AV + D - G + CA

(OP-radiated output power; AV-analyzer value; D-free field attenuation of measurement distance; G-antenna gain+amplifier gain; CA-loss signal path)

Example calculation:

OP [dBm] = -65.0 [dBm] + 50 [dB] - 20 [dBi] + 5 [dB] = -30 [dBm] (1 μ W)

Equipment table:

No.	Setup	Equipment	Type	Manufacturer	Serial No.	INV. No.	Kind of Calibration	Last Calibration	Next Calibration
1	A, B, C	DC power supply, 60Vdc, 50A, 1200 W	6032A	HP	2818A03450	300001040	vKI!	09.12.2020	08.12.2023
2	C	Active Loop Antenna 9 kHz to 30 MHz	6502	EMCO	2210	300001015	vKI!	13.06.2019	12.06.2021
3	A, B, C	Anechoic chamber	FAC 3/5m	MWB / TDK	87400/02	300000996	ev	-/-	-/-
4	A, B, C	Switch / Control Unit	3488A	HP	*	300000199	ne	-/-	-/-
5	A, B	Double-Ridged Waveguide Horn Antenna 1-18.0GHz	3115	EMCO	9709-5289	300000213	vKI!	14.07.2020	13.07.2022
6	B	Band Reject Filter	WRCG1850/1910-1835/1925-40/8SS	Wainwright	23	400000149	ne	-/-	-/-
7	B	Band Reject Filter	WRCG824/849-810/863-60/9SS	Wainwright	6	300003791	ne	-/-	-/-
8	B	Band Reject Filter	WRCG1710/1755-1690/1775-90/14SS	Wainwright	7	300003793	ne	-/-	-/-
9	A, B, C	EMI Test Receiver 20Hz- 26,5GHz	ESU26	R&S	100037	300003555	k	11.12.2020	10.12.2021
10	B	Highpass Filter	WHKX7.0/18G-8SS	Wainwright	19	300003790	ne	-/-	-/-
11	B	High Pass Filter	VHF-3500+	Mini Circuits	-/-	400000193	ne	-/-	-/-
12	B	Broadband Amplifier 0.5-18 GHz	CBLU5184540	CERNEX	22049	300004481	ev	-/-	-/-
13	A, B, C	4U RF Switch Platform	L4491A	Agilent Technologies	MY50000037	300004509	ne	-/-	-/-
14	A, B, C	NEXIO EMV-Software	BAT EMC V3.20.0.17	EMCO	-/-	300004682	ne	-/-	-/-
15	A, B, C	PC	ExOne	F+W	-/-	300004703	ne	-/-	-/-
16	A, B, C	Wideband Radio Communication Tester	CMW500	R&S	102375	300004187	k	12.12.2019	11.12.2021

7.3 Radiated measurements > 18 GHz

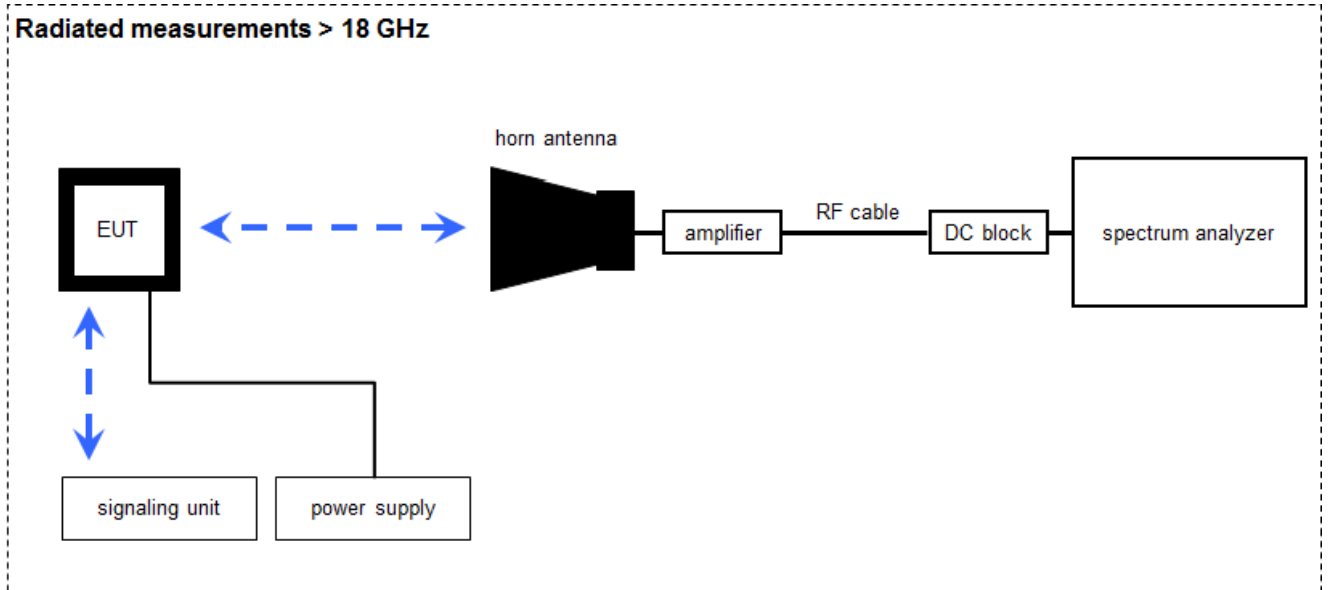

Measurement distance: horn antenna 50 cm

$$OP = AV + D - G + CA$$

(OP-radiated output power; AV-analyzer value; D-free field attenuation of measurement distance; G-antenna gain+amplifier gain; CA-loss signal path)

Example calculation:

$$OP \text{ [dBm]} = -65.0 \text{ [dBm]} + 50.0 \text{ [dB]} - 20.0 \text{ [dBi]} + 5.0 \text{ [dB]} = -30 \text{ [dBm]} \text{ (1 } \mu\text{W)}$$

Equipment table:

No.	Lab / Item	Equipment	Type	Manufacturer	Serial No.	INV. No.	Kind of Calibration	Last Calibration	Next Calibration
1	A	Microwave System Amplifier, 0.5-26.5 GHz	83017A	HP	00419	300002268	ev	-/-	-/-
2	A	Std. Gain Horn Antenna 18.0-26.5 GHz	638	Narda	01096	300000486	vIKI!	21.01.2020	20.01.2022
3	A	Signal Analyzer 40 GHz	FSV40	Rohde & Schwarz	101042	300004517	k	07.12.2020	06.12.2021
4	A	RF-Cable	ST18/SMAm/SMAm /48	Huber & Suhner	Batch no. 600918	400001182	ev	-/-	-/-
5	A	RF-Cable	ST18/SMAm/SMAm /48	Huber & Suhner	Batch no. 127377	400001183	ev	-/-	-/-
6	A	DC-Blocker 0.1-40 GHz	8141A	Inmet	-/-	400001185	ev	-/-	-/-
7	A	Wideband Radio Communication Tester	CMW500	R&S	102375	300004187	k	12.12.2019	11.12.2021

8 Sequence of testing

8.1 Sequence of testing radiated spurious 9 kHz to 30 MHz

Setup

- The equipment is set up to simulate normal operation mode as described in the user manual or defined by the manufacturer.
- If the EUT is a tabletop system, it is placed on a table with 0.8 m height.
- If the EUT is a floor standing device, it is placed directly on the turn table.
- Auxiliary equipment and cables are positioned to simulate normal operation conditions as described in ANSI C 63.4.
- The AC power port of the EUT (if available) is connected to a power outlet below the turntable.
- Measurement distance is 3 m (see ANSI C 63.4) – see test details.
- EUT is set into operation.

Premeasurement*

- The turntable rotates from 0° to 315° using 45° steps.
- The antenna height is 1 m.
- At each turntable position the analyzer sweeps with positive-peak detector to find the maximum of all emissions.

Final measurement

- Identified emissions during the pre-measurement are maximized by the software by rotating the turntable from 0° to 360°.
- Loop antenna is rotated about its vertical axis for maximum response at each azimuth about the EUT. (For certain applications, the loop antenna plane may also need to be positioned horizontally at the specified distance from the EUT)
- The final measurement is done in the position (turntable and elevation) causing the highest emissions with quasi-peak (as described in ANSI C 63.4).
- Final levels, frequency, measuring time, bandwidth, turntable position, correction factor, margin to the limit and limit will be recorded. A plot with the graph of the premeasurement and the limit is stored.

*Note: The sequence will be repeated three times with different EUT orientations.

8.2 Sequence of testing radiated spurious 30 MHz to 1 GHz

Setup

- The equipment is set up to simulate normal operation mode as described in the user manual or defined by the manufacturer.
- If the EUT is a tabletop system, a table with 0.8 m height is used, which is placed on the ground plane.
- If the EUT is a floor standing device, it is placed on the ground plane with insulation between both.
- Auxiliary equipment and cables are positioned to simulate normal operation conditions as described in ANSI C 63.4.
- The AC power port of the EUT (if available) is connected to a power outlet below the turntable.
- Measurement distance is 10 m or 3 m (see ANSI C 63.4) – see test details.
- EUT is set into operation.

Premeasurement

- The turntable rotates from 0° to 315° using 45° steps.
- The antenna is polarized vertical and horizontal.
- The antenna height changes from 1 m to 3 m.
- At each turntable position, antenna polarization and height the analyzer sweeps three times in peak to find the maximum of all emissions.

Final measurement

- The final measurement is performed for at least six highest peaks according to the requirements of the ANSI C63.4.
- Based on antenna and turntable positions at which the peak values are measured the software maximize the peaks by changing turntable position $\pm 45^\circ$ and antenna height between 1 and 4 m.
- The final measurement is done with quasi-peak detector (as described in ANSI C 63.4).
- Final levels, frequency, measuring time, bandwidth, antenna height, antenna polarization, turntable angle, correction factor, margin to the limit and limit are recorded. A plot with the graph of the premeasurement with marked maximum final results and the limit is stored.

8.3 Sequence of testing radiated spurious 1 GHz to 18 GHz

Setup

- The equipment is set up to simulate normal operation mode as described in the user manual or defined by the manufacturer.
- If the EUT is a tabletop system, a 2-axis positioner with 1.5 m height is used.
- If the EUT is a floor standing device, it is placed directly on the turn table.
- Auxiliary equipment and cables are positioned to simulate normal operation conditions as described in ANSI C 63.4.
- The AC power port of the EUT (if available) is connected to a power outlet below the turntable.
- Measurement distance is 3 m (see ANSI C 63.4) – see test details.
- EUT is set into operation.

Premeasurement

- The turntable rotates from 0° to 315° using 45° steps.
- The antenna is polarized vertical and horizontal.
- The antenna height is 1.5 m.
- At each turntable position and antenna polarization the analyzer sweeps with positive peak detector to find the maximum of all emissions.

Final measurement

- The final measurement is performed for at least six highest peaks according to the requirements of the ANSI C63.4.
- Based on antenna and turntable positions at which the peak values are measured the software maximizes the peaks by rotating the turntable from 0° to 360°. This measurement is repeated for different EUT-table positions (0° to 150° in 30°-steps) and for both antenna polarizations.
- The final measurement is done in the position (turntable, EUT-table and antenna polarization) causing the highest emissions with Peak and RMS detector (as described in ANSI C 63.4).
- Final levels, frequency, measuring time, bandwidth, turntable position, EUT-table position, antenna polarization, correction factor, margin to the limit and limit are recorded. A plot with the graph of the premeasurement with marked maximum final results and the limit is stored.

8.4 Sequence of testing radiated spurious above 18 GHz

Setup

- The equipment is set up to simulate normal operation mode as described in the user manual or defined by the manufacturer.
- Auxiliary equipment and cables are positioned to simulate normal operation conditions as described in ANSI C 63.4.
- The AC power port of the EUT (if available) is connected to a power outlet.
- The measurement distance is as appropriate (e.g. 0.5 m).
- The EUT is set into operation.

Premeasurement

- The test antenna is handheld and moved carefully over the EUT to cover the EUT's whole sphere and different polarizations of the antenna.

Final measurement

- The final measurement is performed at the position and antenna orientation causing the highest emissions with Peak and RMS detector (as described in ANSI C 63.4).
- Final levels, frequency, measuring time, bandwidth, correction factor, margin to the limit and limit are recorded. A plot with the graph of the premeasurement and the limit is stored.

9 Measurement uncertainty

Measurement uncertainty	
Test case	Uncertainty
RF output power conducted	± 1 dB
RF output power radiated	± 3 dB
Frequency stability	± 20 Hz
Spurious emissions radiated below 30 MHz	± 3 dB
Spurious emissions radiated 30 MHz to 1 GHz	± 3 dB
Spurious emissions radiated 1 GHz to 12.75 GHz	± 3.7 dB
Spurious emissions radiated above 12.75 GHz	± 4.5 dB
Spurious emissions conducted	± 3 dB
Block edge compliance	± 3 dB
Occupied bandwidth	\pm RBW

10 Summary of measurement results LTE band 2; LTE band 25

<input type="checkbox"/>	No deviations from the technical specifications were ascertained
<input type="checkbox"/>	There were deviations from the technical specifications ascertained
<input checked="" type="checkbox"/>	This test report is only a partial test report. The content and verdict of the performed test cases are listed below.

10.1 LTE – Band 2

TC identifier	Description	verdict	date	Remark
RF-Testing	CFR Part 24 RSS 133	See table	2021-08-06	Delta tests according to manufacturer demand!

Test Case	temperature conditions	power source voltages	C	NC	NA	NP	Remark
RF Output Power	Nominal	Nominal	<input checked="" type="checkbox"/>	<input type="checkbox"/>	<input type="checkbox"/>	<input type="checkbox"/>	-/-
Frequency Stability	Extreme	Extreme	<input type="checkbox"/>	<input type="checkbox"/>	<input type="checkbox"/>	<input checked="" type="checkbox"/>	-/-
Spurious Emissions Radiated	Nominal	Nominal	<input checked="" type="checkbox"/>	<input type="checkbox"/>	<input type="checkbox"/>	<input type="checkbox"/>	-/-
Spurious Emissions Conducted	Nominal	Nominal	<input type="checkbox"/>	<input type="checkbox"/>	<input type="checkbox"/>	<input checked="" type="checkbox"/>	-/-
Block Edge Compliance	Nominal	Nominal	<input type="checkbox"/>	<input type="checkbox"/>	<input type="checkbox"/>	<input checked="" type="checkbox"/>	-/-
Occupied Bandwidth	Nominal	Nominal	<input type="checkbox"/>	<input type="checkbox"/>	<input type="checkbox"/>	<input checked="" type="checkbox"/>	-/-

Notes:

C	Compliant	NC	Not compliant	NA	Not applicable	NP	Not performed
----------	-----------	-----------	---------------	-----------	----------------	-----------	---------------

10.2 LTE – Band 25

TC identifier	Description	verdict	date	Remark
RF-Testing	CFR Part 90; RSS 133	See table	2021-08-06	Delta tests according to manufacturer demand!

Test Case	temperature conditions	power source voltages	C	NC	NA	NP	Remark
RF Output Power	Nominal	Nominal	<input type="checkbox"/>	<input type="checkbox"/>	<input type="checkbox"/>	<input checked="" type="checkbox"/>	-/-
Frequency Stability	Extreme	Extreme	<input type="checkbox"/>	<input type="checkbox"/>	<input type="checkbox"/>	<input checked="" type="checkbox"/>	-/-
Spurious Emissions Radiated	Nominal	Nominal	<input checked="" type="checkbox"/>	<input type="checkbox"/>	<input type="checkbox"/>	<input type="checkbox"/>	-/-
Spurious Emissions Conducted	Nominal	Nominal	<input type="checkbox"/>	<input type="checkbox"/>	<input type="checkbox"/>	<input checked="" type="checkbox"/>	-/-
Block Edge Compliance	Nominal	Nominal	<input type="checkbox"/>	<input type="checkbox"/>	<input type="checkbox"/>	<input checked="" type="checkbox"/>	-/-
Occupied Bandwidth	Nominal	Nominal	<input type="checkbox"/>	<input type="checkbox"/>	<input type="checkbox"/>	<input checked="" type="checkbox"/>	-/-

Notes:

C	Compliant	NC	Not compliant	NA	Not applicable	NP	Not performed
----------	-----------	-----------	---------------	-----------	----------------	-----------	---------------

11 RF measurements LTE band 2

11.1 Description of test setup

For the spurious measurements we use the substitution method according TIA/EIA 603.

11.2 Results

11.2.1 RF output power

Description:

This paragraph contains average power, peak output power and EIRP measurements for the mobile station. In all cases, the peak output power is within the required mask (this mask is specified in the JTC standards, TIA PN3389 Vol. 1 Chap 7, and is no FCC requirement).

Measurement:

The mobile was set up for the maximum output power with pseudo random data modulation.

Measurement parameters	
Setup	See chapter 7.2 – A
Measurement uncertainty	See chapter 9

Limits:

FCC	ISED
Nominal Peak Output Power	
+33.00 dBm	
In measuring transmissions in this band using an average power technique, the peak-to-average ratio (PAR) of the transmission may not exceed 13 dB.	

Results: Cat M1

Output Power (radiated)			
Bandwidth and RB settings	Frequency (MHz)	Average Output Power (dBm) QPSK	Average Output Power (dBm) 16QAM
1.4 MHz 1#0	1850.7	21.2	19.9
1.4 MHz 1#0	1880.0	20.2	19.9
1.4 MHz 1#5	1909.3	20.5	19.4

Results: NB-IOT2

Output Power (radiated)			
Settings	Frequency (MHz)	Average Output Power (dBm) BPSK	Average Output Power (dBm) QPSK
15 kHz sub-carrier spacing	1850.7	20.6	20.6
15 kHz sub-carrier spacing	1880.0	20.4	20.4
15 kHz sub-carrier spacing	1909.3	20.7	20.7

11.2.2 Spurious emissions radiated

Description:

The following steps outline the procedure used to measure the radiated emissions from the mobile station. The site is constructed in accordance with ANSI C63.4:2014 requirements and is recognized by the FCC to be in compliance for a 3 and a 10 meter site. The spectrum was scanned from 30 MHz to the 10th harmonic of the highest frequency generated within the equipment, which is the transmitted carrier that can be as high as 1910 MHz. Measurement made up to 25 GHz. The resolution bandwidth is set as outlined in Part 24.238. The spectrum was scanned with the mobile station transmitting at carrier frequencies that pertain to low, mid and high channels of the LTE band II.

Measurement:

Measurement parameters	
Detector	Peak
Sweep time	2 sec.
Video bandwidth	Below 1 GHz: 100 kHz Above 1 GHz: 1 MHz
Resolution bandwidth	Below 1 GHz: 100 kHz Above 1 GHz: 1 MHz
Span	100 MHz Steps
Trace mode	Max Hold
Setup	See chapter 7.1 - A; 7.2 – B&C ; 7.3 - A
Measurement uncertainty	See chapter 9

Limits:

FCC	ISED
Spurious Emissions Radiated	
Attenuation $\geq 43 + 10\log(P)$ / (P, Power in Watts)	
-13 dBm	

Cat NB2

Spurious Emission Level (dBm)								
Harmonic	Lowest channel Freq. (MHz)	Level [dBm]	Harmonic	Middle channel Freq. (MHz)	Level [dBm]	Harmonic	Highest channel Freq. (MHz)	Level [dBm]
2	3710.0	All detected emissions are more than 20dB below the limit!	2	3760.0	All detected emissions are more than 20dB below the limit!	2	3810.0	All detected emissions are more than 20dB below the limit!
3	5565.0		3	5640.0		3	5715.0	
4	7420.0		4	7520.0		4	7620.0	
5	9275.0		5	9400.0		5	9525.0	
6	11130.0		6	11280.0		6	11430.0	
7	12985.0		7	13160.0		7	13335.0	
8	14840.0		8	15040.0		8	15240.0	
9	16695.0		9	16920.0		9	17145.0	
10	18550.0		10	18800.0		10	19050.0	

Cat M1

Spurious Emission Level (dBm)								
Harmonic	Lowest channel Freq. (MHz)	Level [dBm]	Harmonic	Middle channel Freq. (MHz)	Level [dBm]	Harmonic	Highest channel Freq. (MHz)	Level [dBm]
2	3710.0	All detected emissions are more than 20dB below the limit!	2	3760.0	All detected emissions are more than 20dB below the limit!	2	3810.0	All detected emissions are more than 20dB below the limit!
3	5565.0		3	5640.0		3	5715.0	
4	7420.0		4	7520.0		4	7620.0	
5	9275.0		5	9400.0		5	9525.0	
6	11130.0		6	11280.0		6	11430.0	
7	12985.0		7	13160.0		7	13335.0	
8	14840.0		8	15040.0		8	15240.0	
9	16695.0		9	16920.0		9	17145.0	
10	18550.0		10	18800.0		10	19050.0	

Results: Cat M1

Plot 1: Channel 18900 (Traffic mode up to 30 MHz)

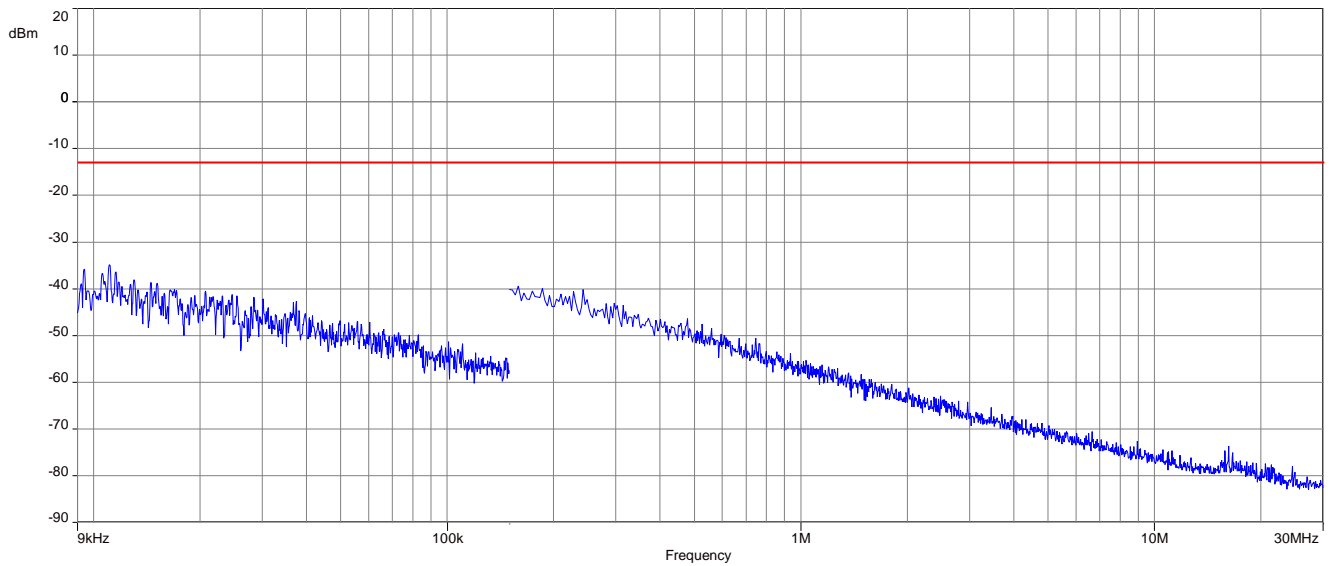

Plot 2: Channel 18900 (30 MHz – 1 GHz)

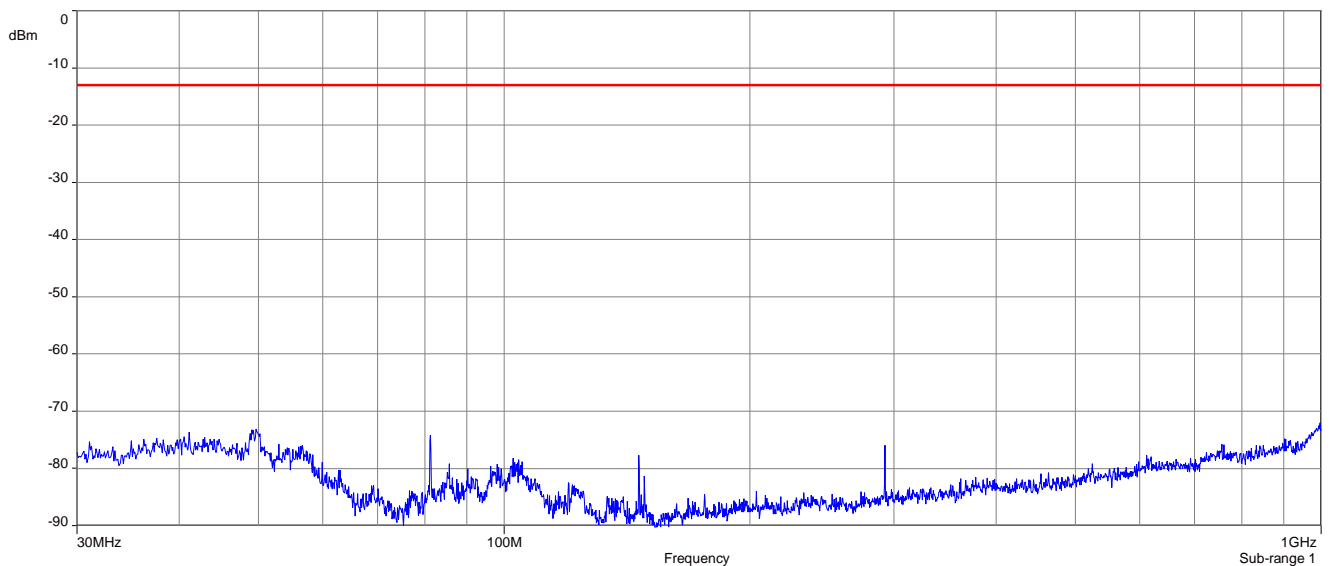

Plot 3: Channel 18900 (1 GHz – 18 GHz)

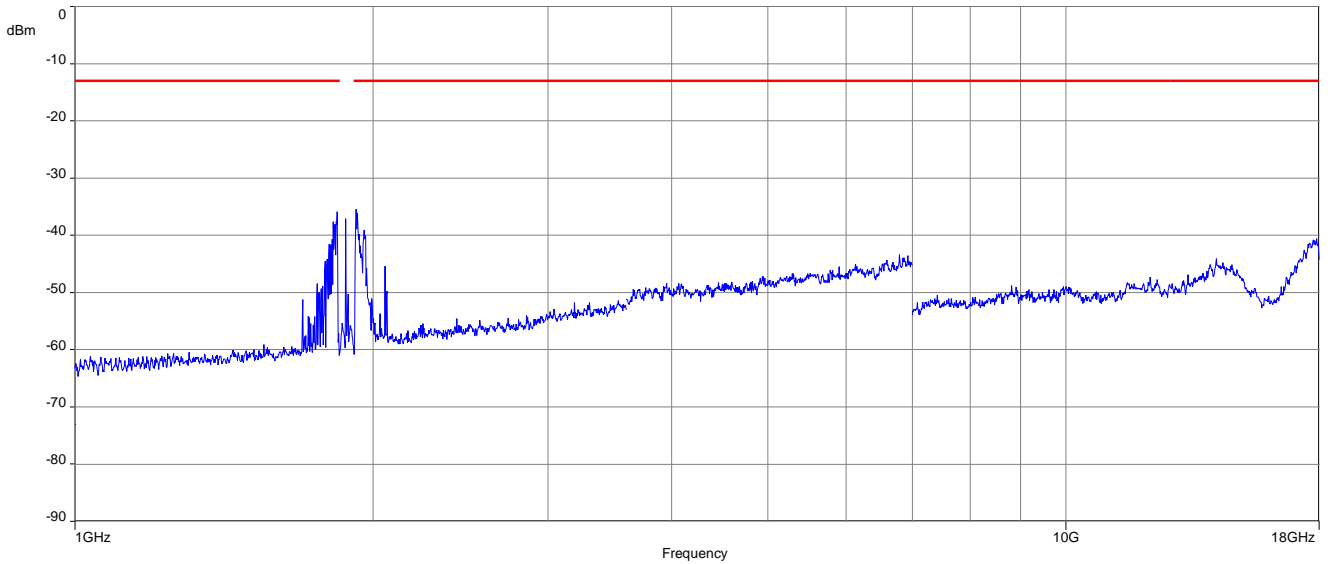

Carrier notched with 1.9 GHz rejection filter

Plot 4: Channel 18900 (18 GHz – 26 GHz)

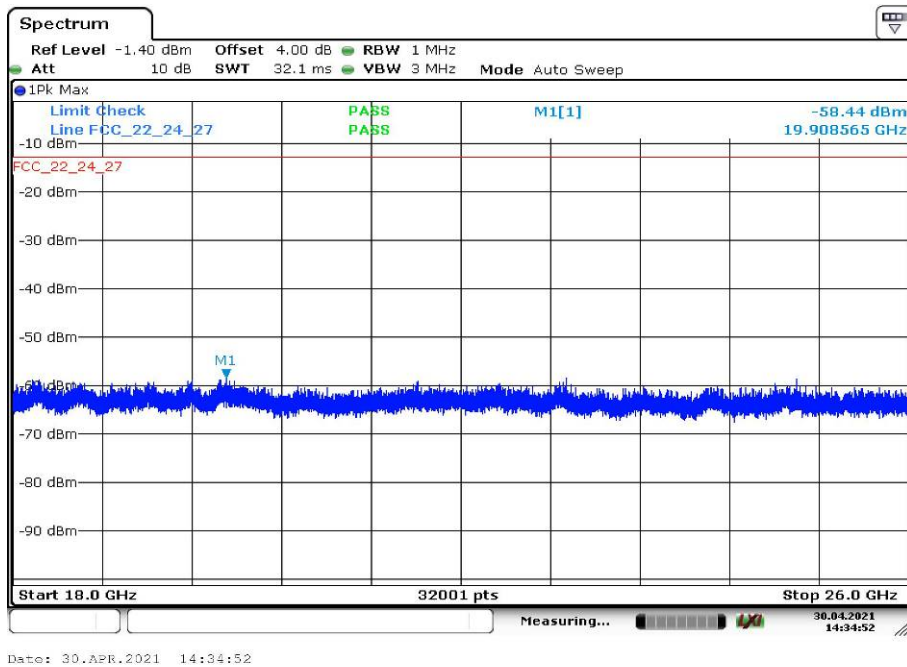

Results: Cat NB2

Plot 1: Channel 18900 (Traffic mode up to 30 MHz)

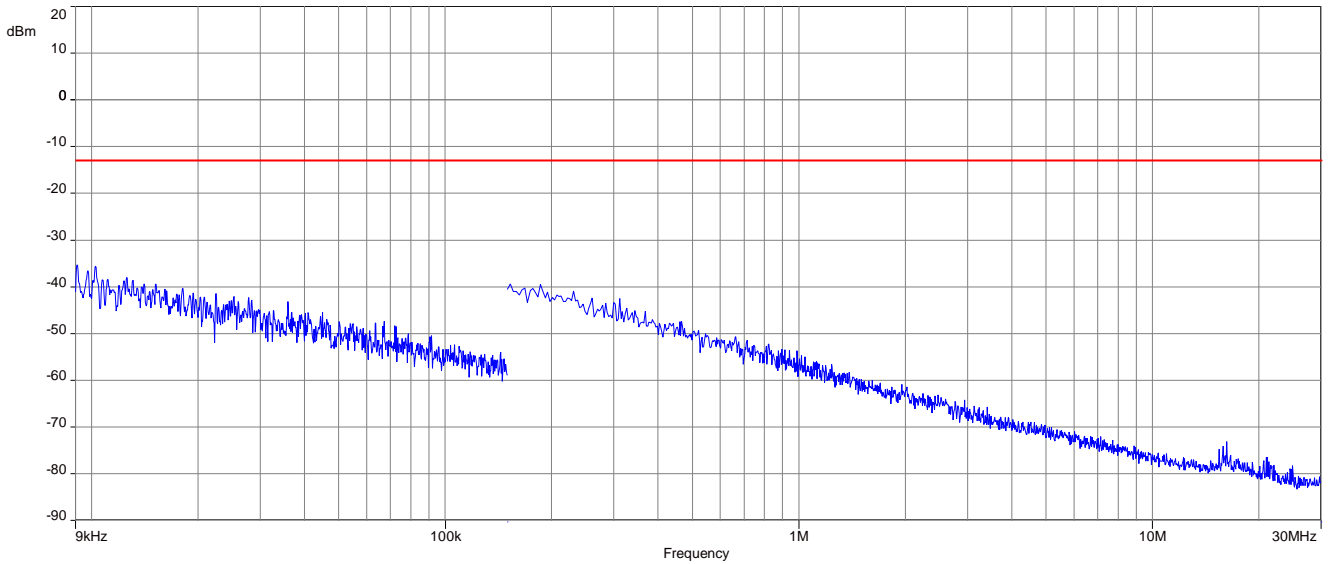

Plot 2: Channel 18900 (30 MHz – 1 GHz)

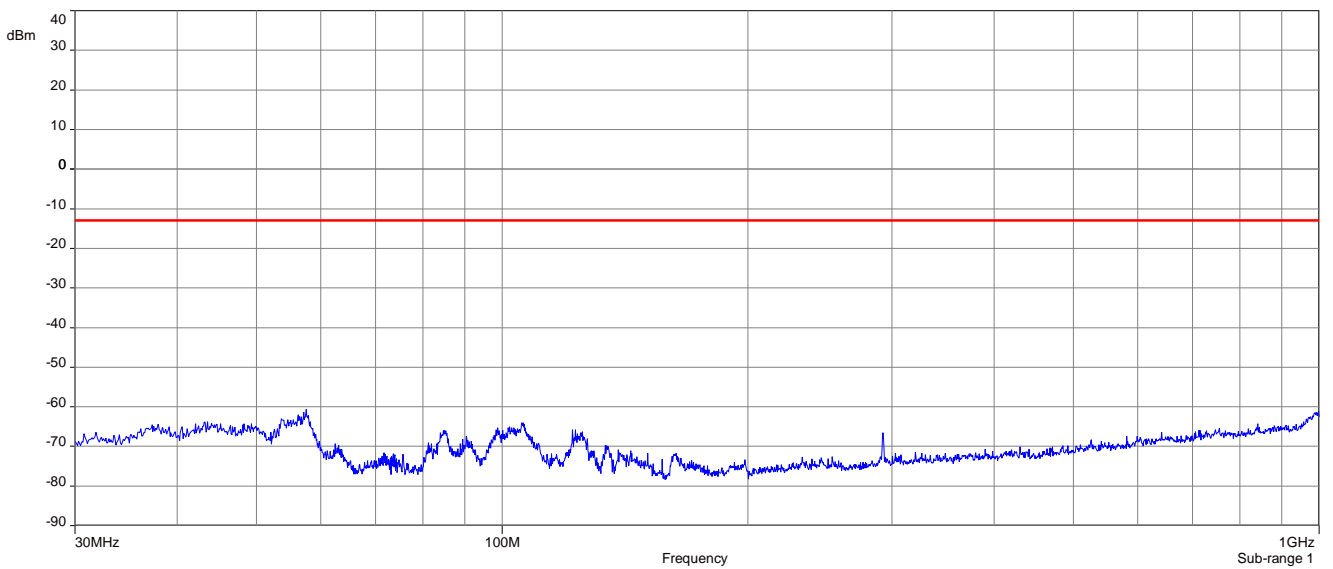

Plot 3: Channel 18900 (1 GHz – 18 GHz)

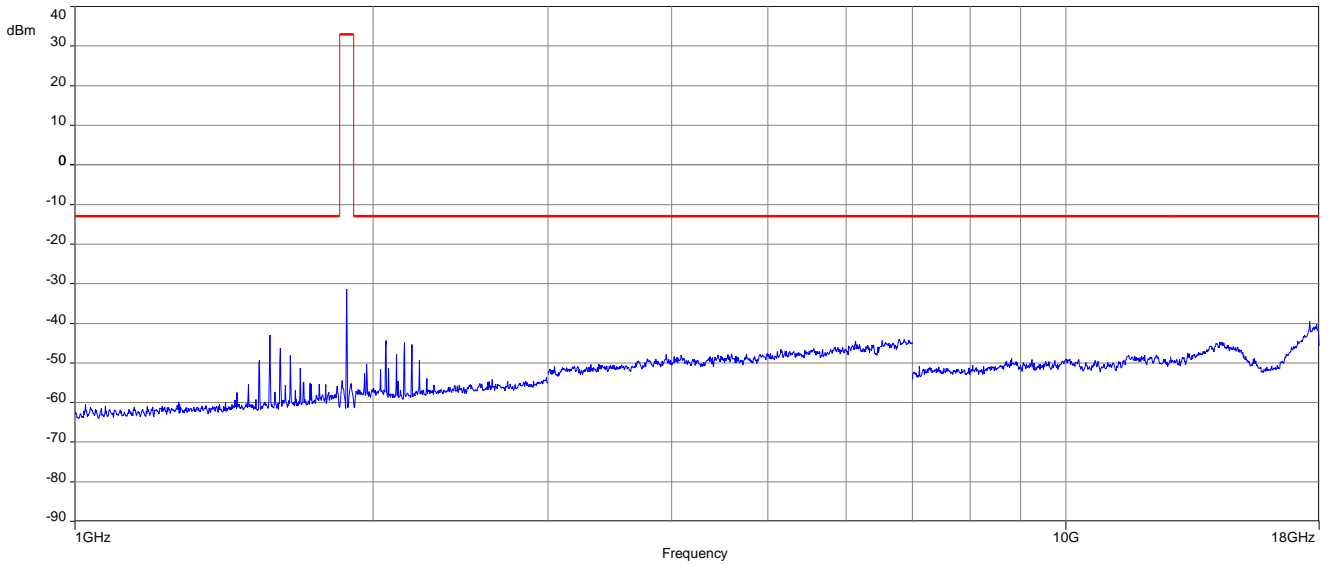

Carrier notched with 1.9 GHz rejection filter

Plot 4: Channel 18900 (18 GHz – 26 GHz)

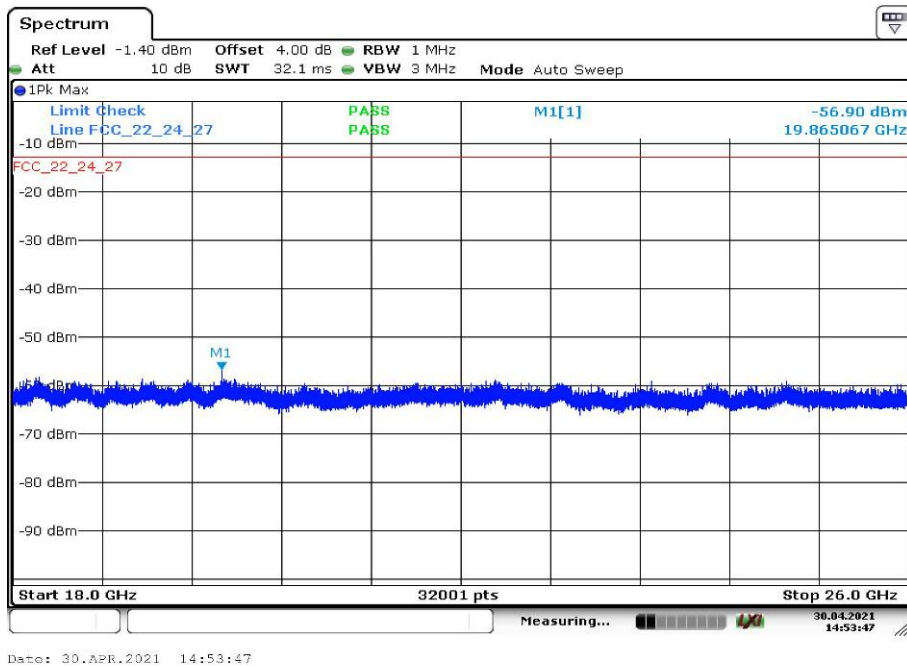

12 RF measurements LTE band 25

12.1 Description of test setup

For the spurious measurements we use the substitution method according TIA/EIA 603.

12.2 Results

12.2.1 RF output power

Description:

This paragraph contains average power, peak output power and EIRP measurements for the mobile station. In all cases, the peak output power is within the required mask (this mask is specified in the JTC standards, TIA PN3389 Vol. 1 Chap 7, and is no FCC requirement).

Measurement:

The mobile was set up for the maximum output power with pseudo random data modulation.

Measurement parameters	
Setup	See chapter 7.2 – A
Measurement uncertainty	See chapter 9

Limits:

FCC	ISED
Nominal Peak Output Power	
+33.00 dBm	
In measuring transmissions in this band using an average power technique, the peak-to-average ratio (PAR) of the transmission may not exceed 13 dB.	

Results: Cat M1

Output Power (radiated)			
Bandwidth and RB settings	Frequency (MHz)	Average Output Power (dBm) QPSK	Average Output Power (dBm) 16QAM
1.4 MHz 1#0	1850.2	20.8	19.8
1.4 MHz 1#0	1882.5	19.9	19.6
1.4 MHz 1#5	1914.8	19.9	20.0

Results: NB-IOT2

Output Power (radiated)			
Settings	Frequency (MHz)	Average Output Power (dBm) BPSK	Average Output Power (dBm) QPSK
15 kHz sub-carrier spacing	1850.2	20.3	20.2
15 kHz sub-carrier spacing	1882.5	20.3	20.2
15 kHz sub-carrier spacing	1914.8	20.3	20.3

12.2.2 Spurious emissions radiated

Description:

The following steps outline the procedure used to measure the radiated emissions from the mobile station. The site is constructed in accordance with ANSI C63.4:2014 requirements and is recognized by the FCC to be in compliance for a 3 and a 10 meter site. The spectrum was scanned from 30 MHz to the 10th harmonic of the highest frequency generated within the equipment, which is the transmitted carrier that can be as high as 1914.3 MHz. Measurement made up to 25 GHz. The resolution bandwidth is set as outlined in Part 24.238. The spectrum was scanned with the mobile station transmitting at carrier frequencies that pertain to low, mid and high channels of the LTE band II.

Measurement:

Measurement parameters	
Detector	Peak
Sweep time	2 sec.
Video bandwidth	Below 1 GHz: 100 kHz Above 1 GHz: 1 MHz
Resolution bandwidth	Below 1 GHz: 100 kHz Above 1 GHz: 1 MHz
Span	100 MHz Steps
Trace mode	Max Hold
Setup	See chapter 7.1 - A; 7.2 - B&C ; 7.3 - A
Measurement uncertainty	See chapter 9

Limits:

FCC	ISED
Spurious Emissions Radiated	
Attenuation $\geq 43 + 10\log(P) / (P, \text{Power in Watts})$	
-13 dBm	

Cat M1

Spurious Emission Level (dBm)								
Harmonic	Lowest channel Freq. (MHz)	Level [dBm]	Harmonic	Middle channel Freq. (MHz)	Level [dBm]	Harmonic	Highest channel Freq. (MHz)	Level [dBm]
2	3710.0	All detected emissions are more than 20dB below the limit!	2	3760.0	All detected emissions are more than 20dB below the limit!	2	3810.0	All detected emissions are more than 20dB below the limit!
3	5565.0		3	5640.0		3	5715.0	
4	7420.0		4	7520.0		4	7620.0	
5	9275.0		5	9400.0		5	9525.0	
6	11130.0		6	11280.0		6	11430.0	
7	12985.0		7	13160.0		7	13335.0	
8	14840.0		8	15040.0		8	15240.0	
9	16695.0		9	16920.0		9	17145.0	
10	18550.0		10	18800.0		10	19050.0	

Cat NB2

Spurious Emission Level (dBm)								
Harmonic	Lowest channel Freq. (MHz)	Level [dBm]	Harmonic	Middle channel Freq. (MHz)	Level [dBm]	Harmonic	Highest channel Freq. (MHz)	Level [dBm]
2	3710.0	All detected emissions are more than 20dB below the limit!	2	3760.0	All detected emissions are more than 20dB below the limit!	2	3810.0	All detected emissions are more than 20dB below the limit!
3	5565.0		3	5640.0		3	5715.0	
4	7420.0		4	7520.0		4	7620.0	
5	9275.0		5	9400.0		5	9525.0	
6	11130.0		6	11280.0		6	11430.0	
7	12985.0		7	13160.0		7	13335.0	
8	14840.0		8	15040.0		8	15240.0	
9	16695.0		9	16920.0		9	17145.0	
10	18550.0		10	18800.0		10	19050.0	

Results: Cat M1

Plot 1: Channel 18900 (Traffic mode up to 30 MHz)

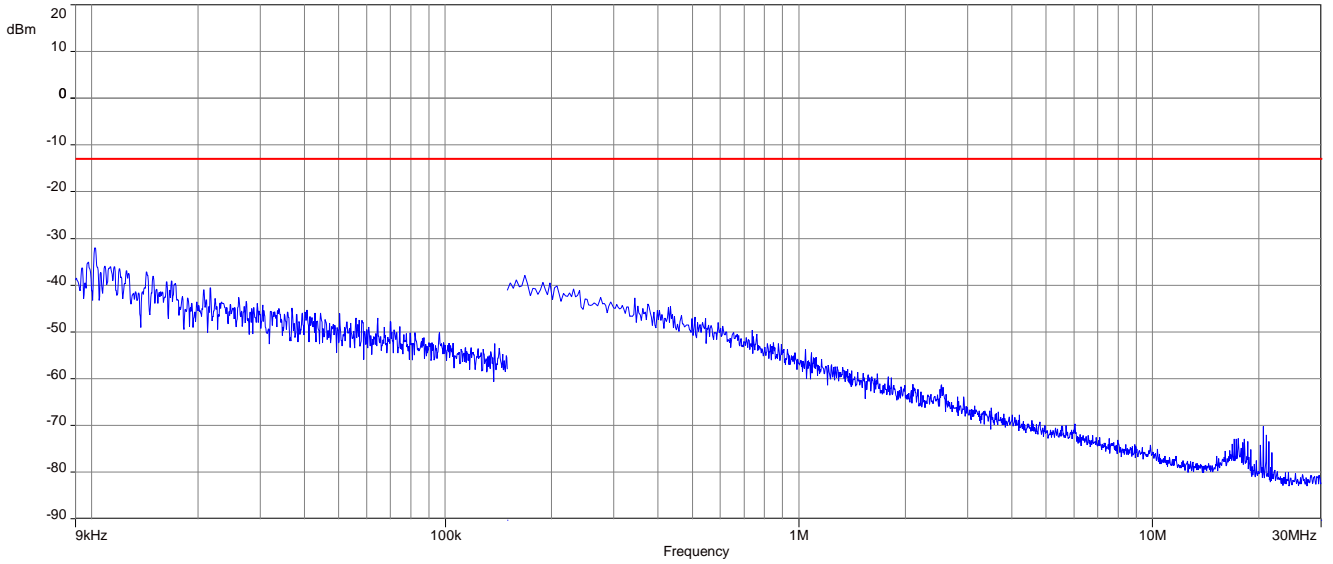

Plot 2: Channel 18900 (30 MHz – 1 GHz)

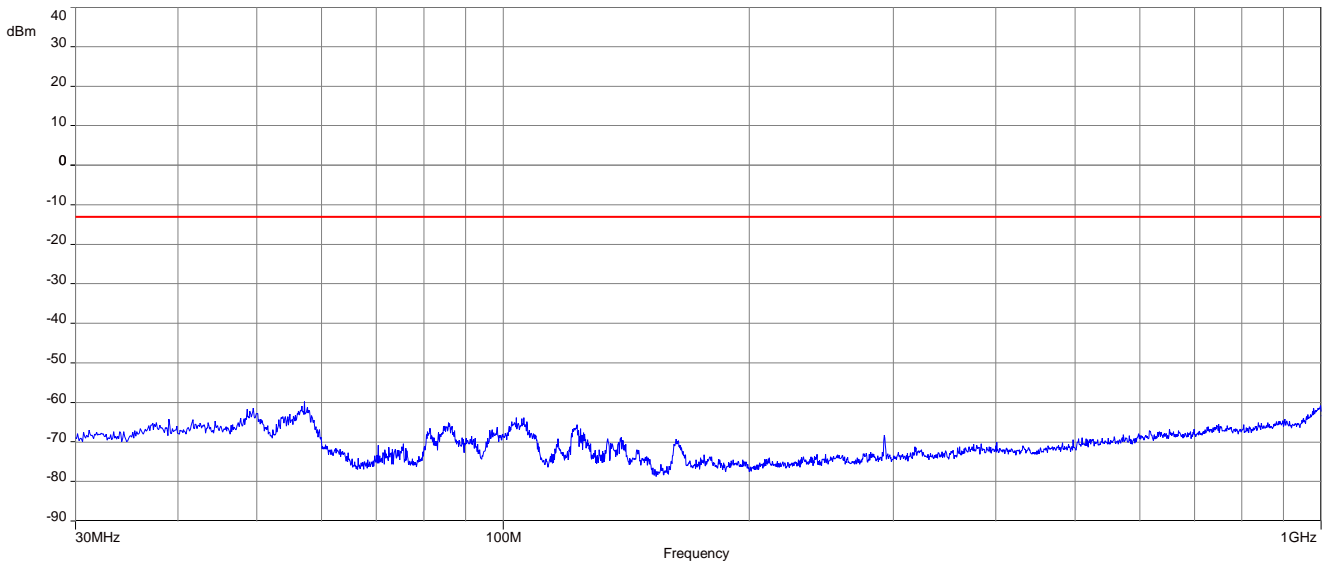

Plot 3: Channel 18900 (1 GHz – 18 GHz)

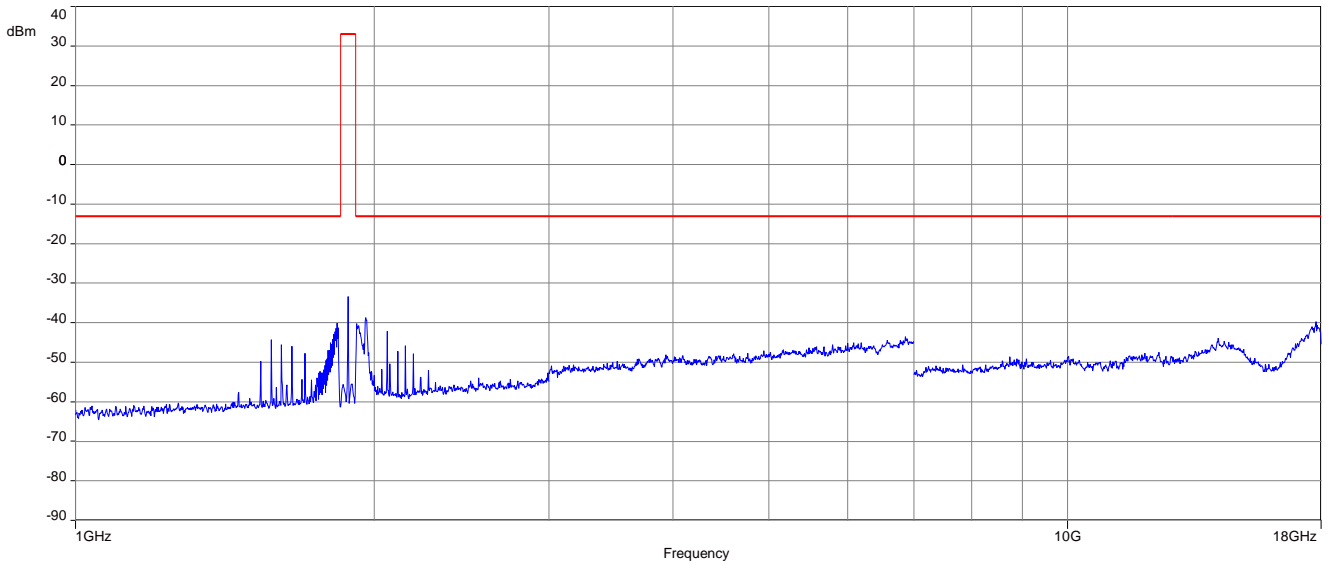

Carrier notched with 1.9 GHz rejection filter

Plot 4: Channel 18900 (18 GHz – 26 GHz)

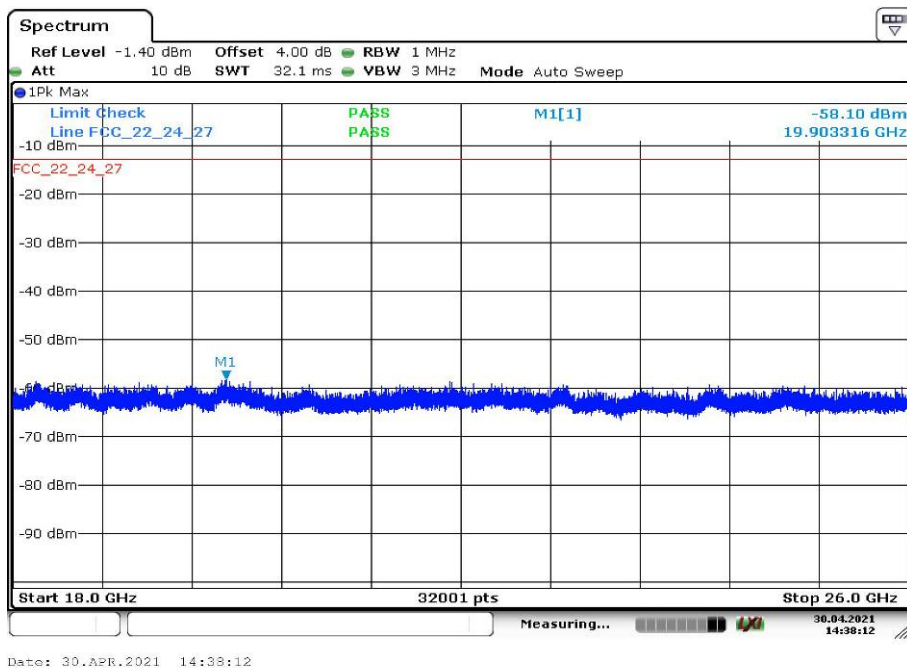

Results: Cat NB2

Plot 1: Channel 18900 (Traffic mode up to 30 MHz)

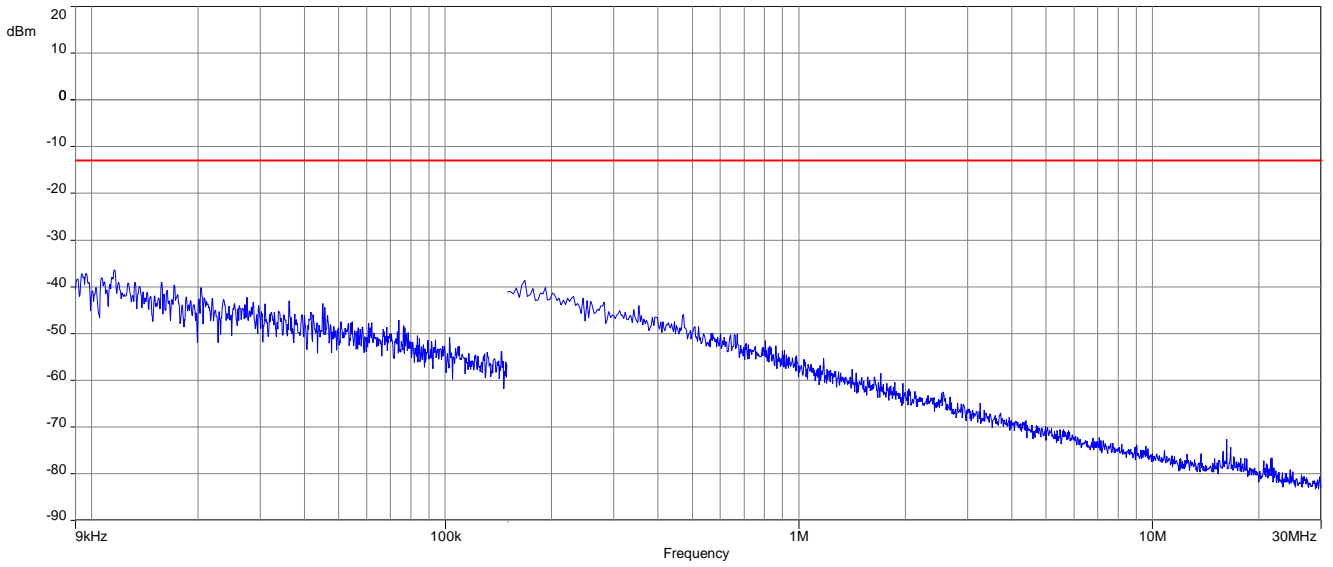

Plot 2: Channel 18900 (30 MHz – 1 GHz)

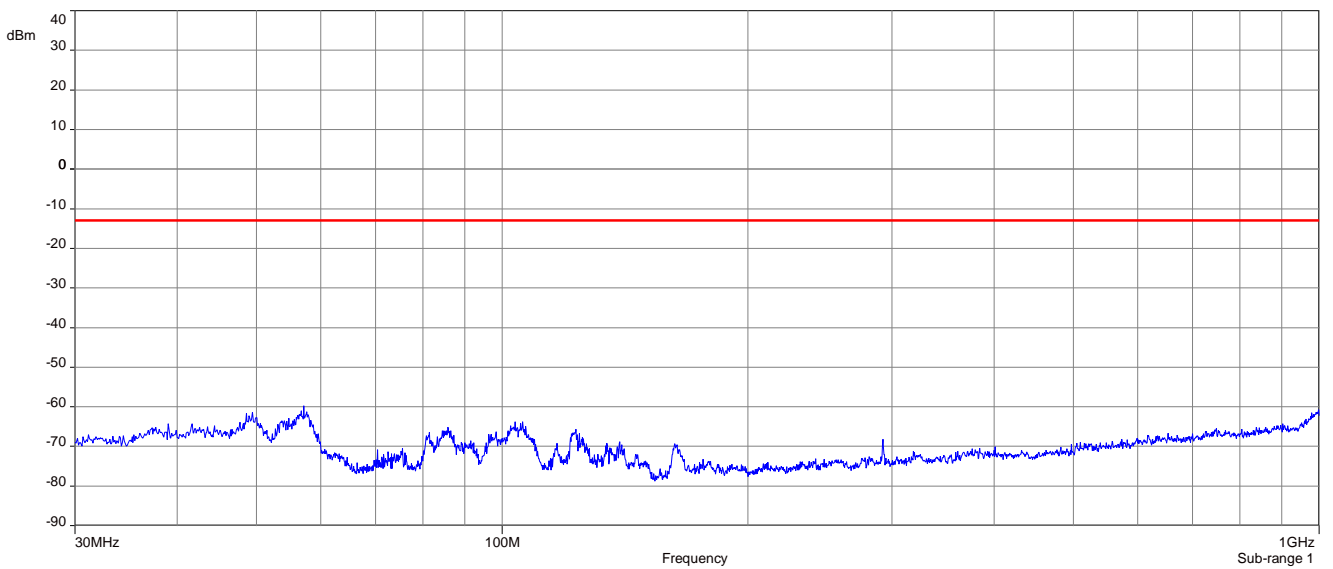

Plot 3: Channel 18900 (1 GHz – 18 GHz)

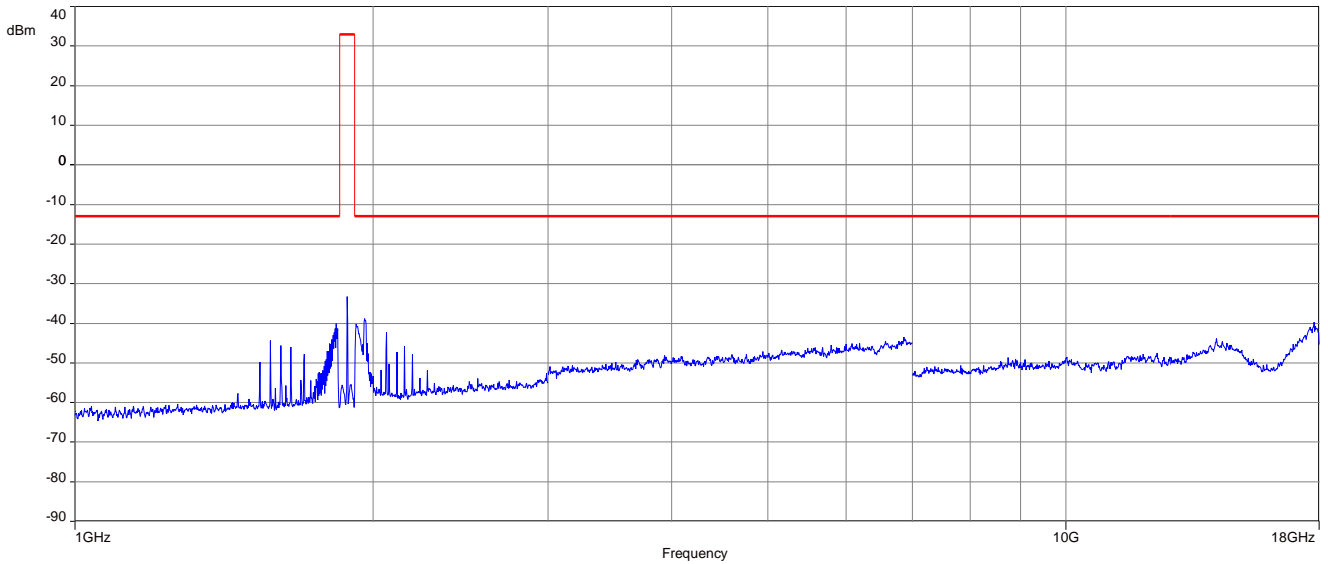

Carrier notch ed with 1.9 GHz rejection filter

Plot 4: Channel 18900 (18 GHz – 26 GHz)

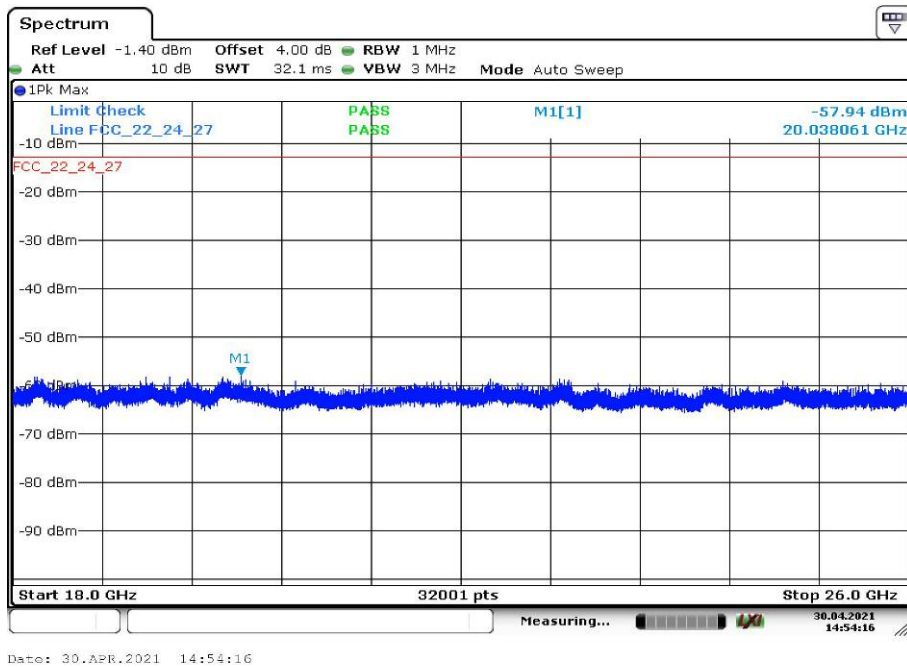

13 Summary of measurement results LTE band 5; LTE band 26

<input type="checkbox"/>	No deviations from the technical specifications were ascertained
<input type="checkbox"/>	There were deviations from the technical specifications ascertained
<input checked="" type="checkbox"/>	This test report is only a partial test report. The content and verdict of the performed test cases are listed below.

13.1 LTE – Band 5

TC identifier	Description	verdict	date	Remark
RF-Testing	CFR Part 22 RSS 132	See table	2021-08-06	Delta tests according to manufacturer demand!

Test Case	temperature conditions	power source voltages	C	NC	NA	NP	Remark
RF Output Power	Nominal	Nominal	<input type="checkbox"/>	<input type="checkbox"/>	<input type="checkbox"/>	<input checked="" type="checkbox"/>	-/-
Frequency Stability	Extreme	Extreme	<input type="checkbox"/>	<input type="checkbox"/>	<input type="checkbox"/>	<input checked="" type="checkbox"/>	-/-
Spurious Emissions Radiated	Nominal	Nominal	<input checked="" type="checkbox"/>	<input type="checkbox"/>	<input type="checkbox"/>	<input type="checkbox"/>	-/-
Spurious Emissions Conducted	Nominal	Nominal	<input type="checkbox"/>	<input type="checkbox"/>	<input type="checkbox"/>	<input checked="" type="checkbox"/>	-/-
Block Edge Compliance	Nominal	Nominal	<input type="checkbox"/>	<input type="checkbox"/>	<input type="checkbox"/>	<input checked="" type="checkbox"/>	-/-
Occupied Bandwidth	Nominal	Nominal	<input type="checkbox"/>	<input type="checkbox"/>	<input type="checkbox"/>	<input checked="" type="checkbox"/>	-/-

Notes:

C	Compliant	NC	Not compliant	NA	Not applicable	NP	Not performed
----------	-----------	-----------	---------------	-----------	----------------	-----------	---------------

13.2 LTE – Band 26

TC identifier	Description	verdict	date	Remark
RF-Testing	CFR Part 22; Part 90	See table	2021-08-06	Delta tests according to manufacturer demand!

Test Case	temperature conditions	power source voltages	C	NC	NA	NP	Remark
RF Output Power	Nominal	Nominal	<input checked="" type="checkbox"/>	<input type="checkbox"/>	<input type="checkbox"/>	<input type="checkbox"/>	-/-
Frequency Stability	Extreme	Extreme	<input type="checkbox"/>	<input type="checkbox"/>	<input type="checkbox"/>	<input checked="" type="checkbox"/>	-/-
Spurious Emissions Radiated	Nominal	Nominal	<input checked="" type="checkbox"/>	<input type="checkbox"/>	<input type="checkbox"/>	<input type="checkbox"/>	-/-
Spurious Emissions Conducted	Nominal	Nominal	<input type="checkbox"/>	<input type="checkbox"/>	<input type="checkbox"/>	<input checked="" type="checkbox"/>	-/-
Block Edge Compliance	Nominal	Nominal	<input type="checkbox"/>	<input type="checkbox"/>	<input type="checkbox"/>	<input checked="" type="checkbox"/>	-/-
Occupied Bandwidth	Nominal	Nominal	<input type="checkbox"/>	<input type="checkbox"/>	<input type="checkbox"/>	<input checked="" type="checkbox"/>	-/-

Notes:

C	Compliant	NC	Not compliant	NA	Not applicable	NP	Not performed
----------	-----------	-----------	---------------	-----------	----------------	-----------	---------------

14 RF measurements LTE band 5

14.1 Description of test setup

For the spurious measurements we use the substitution method according TIA/EIA 603.

14.2 Results

The EUT was set to transmit the maximum power.

14.2.1 RF output power

Description:

This paragraph contains average power, peak output power and EIRP measurements for the mobile station. In all cases, the peak output power is within the required mask (this mask is specified in the JTC standards, TIA PN3389 Vol. 1 Chap 7, and is no FCC requirement).

Measurement:

The mobile was set up for the maximum output power with pseudo random data modulation.

Measurement parameters	
Setup	See chapter 7.1 – A
Measurement uncertainty	See chapter 9

Limits:

FCC	ISED
Nominal Peak Output Power	
+38.45 dBm	
In measuring transmissions in this band using an average power technique, the peak-to-average ratio (PAR) of the transmission may not exceed 13 dB.	

Results: Cat M1

Output Power (radiated)			
Bandwidth and RB settings	Frequency (MHz)	Average Output Power (dBm) QPSK	Average Output Power (dBm) 16QAM
1.4 MHz 1#0	824.2	19.8	18.4
1.4 MHz 1#0	836.5	19.1	19.4
1.4 MHz 1#5	848.8	19.3	18.3

Results: NB-IOT2

Output Power (radiated)			
Settings	Frequency (MHz)	Average Output Power (dBm) BPSK	Average Output Power (dBm) QPSK
15 kHz sub-carrier spacing	824.2	19.6	19.6
15 kHz sub-carrier spacing	836.5	19.4	19.6
15 kHz sub-carrier spacing	848.8	19.6	19.6

14.2.2 Spurious emissions radiated

Description:

The following steps outline the procedure used to measure the radiated emissions from the mobile station. The site is constructed in accordance with ANSI C63.4:2014 requirements and is recognized by the FCC to be in compliance for a 3 and a 10 meter site. The spectrum was scanned from 30 MHz to the 10th harmonic of the highest frequency generated within the equipment, which is the transmitted carrier that can be as high as 846.6 MHz. Measurement made up to 12.75 GHz. The resolution bandwidth is set as outlined in Part 22.917. The spectrum was scanned with the mobile station transmitting at carrier frequencies that pertain to low, mid and high channels of the LTE band V.

Measurement:

Measurement parameters	
Detector	Peak
Sweep time	2 sec.
Video bandwidth	Below 1 GHz: 100 kHz Above 1 GHz: 1 MHz
Resolution bandwidth	Below 1 GHz: 100 kHz Above 1 GHz: 1 MHz
Span	100 MHz Steps
Trace mode	Max Hold
Setup	See chapter 7.1 - A; 7.2 - B&C
Measurement uncertainty	See chapter 9

Limits:

FCC	IC
Spurious Emissions Radiated	
Attenuation $\geq 43 + 10\log(P) / (P, \text{Power in Watts})$	
-13 dBm	

Cat M1

Spurious Emission Level (dBm)								
Harmonic	Lowest channel Freq. (MHz)	Level [dBm]	Harmonic	Middle channel Freq. (MHz)	Level [dBm]	Harmonic	Highest channel Freq. (MHz)	Level [dBm]
2	1658.0	All detected emissions are more than 20dB below the limit!	2	1673.0	All detected emissions are more than 20dB below the limit!	2	1688.0	All detected emissions are more than 20dB below the limit!
3	2487.0		3	2509.5		3	2532.0	
4	3316.0		4	3346.0		4	3376.0	
5	4145.0		5	4182.5		5	4220.0	
6	4974.0		6	5019.0		6	5064.0	
7	5803.0		7	5855.5		7	5908.0	
8	6632.0		8	6692.0		8	6752.0	
9	7461.0		9	7528.5		9	7596.0	
10	8290.0		10	8365.0		10	8440.0	

Cat NB2

Spurious Emission Level (dBm)								
Harmonic	Lowest channel Freq. (MHz)	Level [dBm]	Harmonic	Middle channel Freq. (MHz)	Level [dBm]	Harmonic	Highest channel Freq. (MHz)	Level [dBm]
2	1658.0	All detected emissions are more than 20dB below the limit!	2	1673.0	All detected emissions are more than 20dB below the limit!	2	1688.0	All detected emissions are more than 20dB below the limit!
3	2487.0		3	2509.5		3	2532.0	
4	3316.0		4	3346.0		4	3376.0	
5	4145.0		5	4182.5		5	4220.0	
6	4974.0		6	5019.0		6	5064.0	
7	5803.0		7	5855.5		7	5908.0	
8	6632.0		8	6692.0		8	6752.0	
9	7461.0		9	7528.5		9	7596.0	
10	8290.0		10	8365.0		10	8440.0	

Results: Cat M1

Plot 1: Channel 20525 (Traffic mode up to 30 MHz)

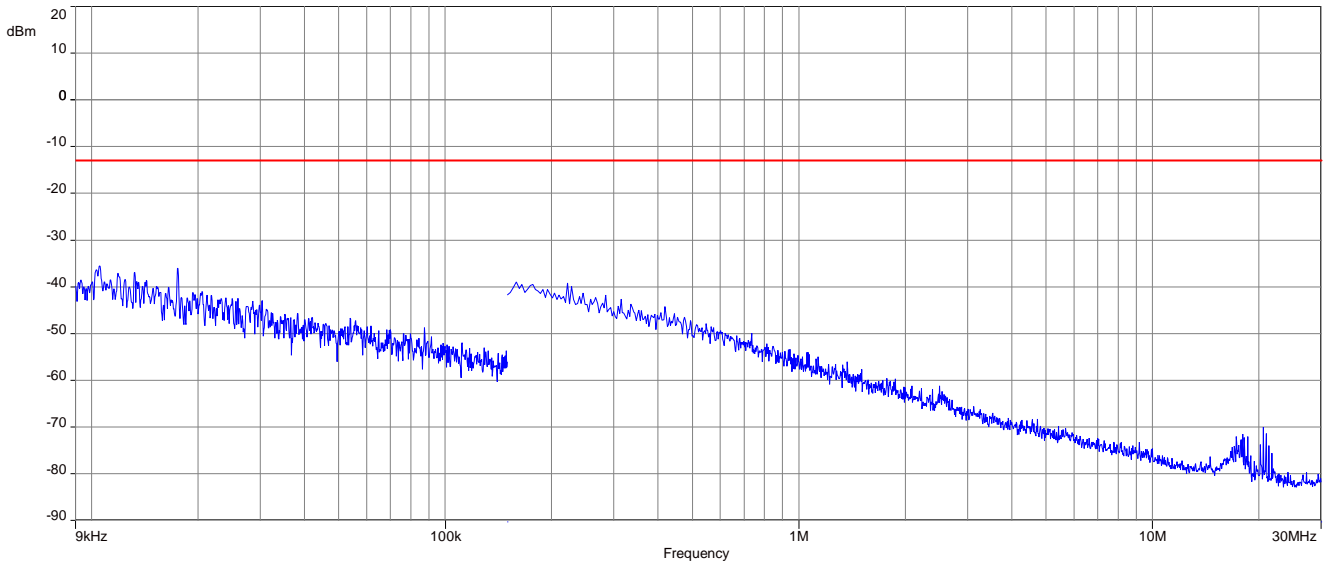

Plot 2: Channel 20525 (30 MHz – 1 GHz)

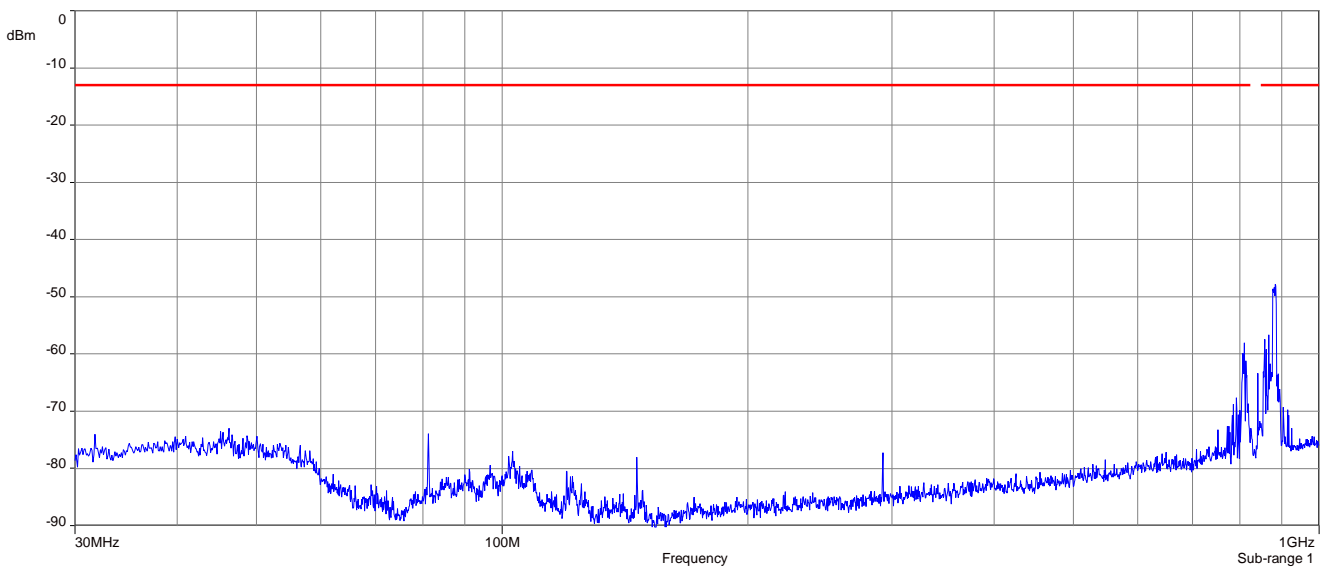

Plot 3: Channel 20525 (1 GHz – 12.75 GHz)

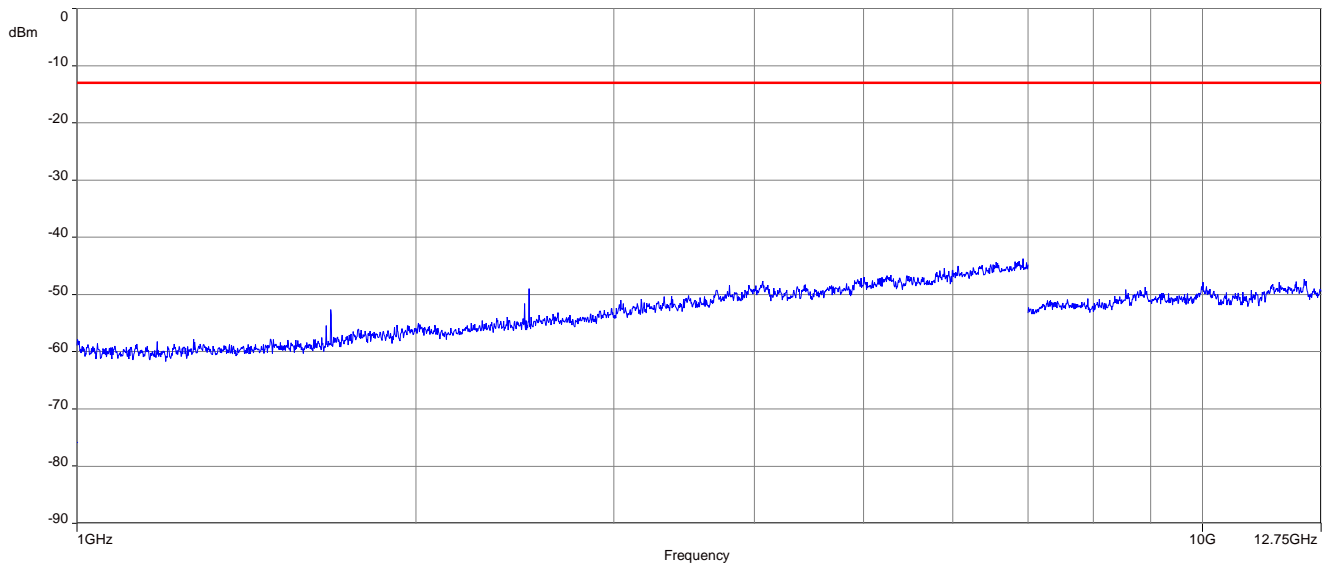

Results: Cat NB2

Plot 1: Channel 20525 (Traffic mode up to 30 MHz)

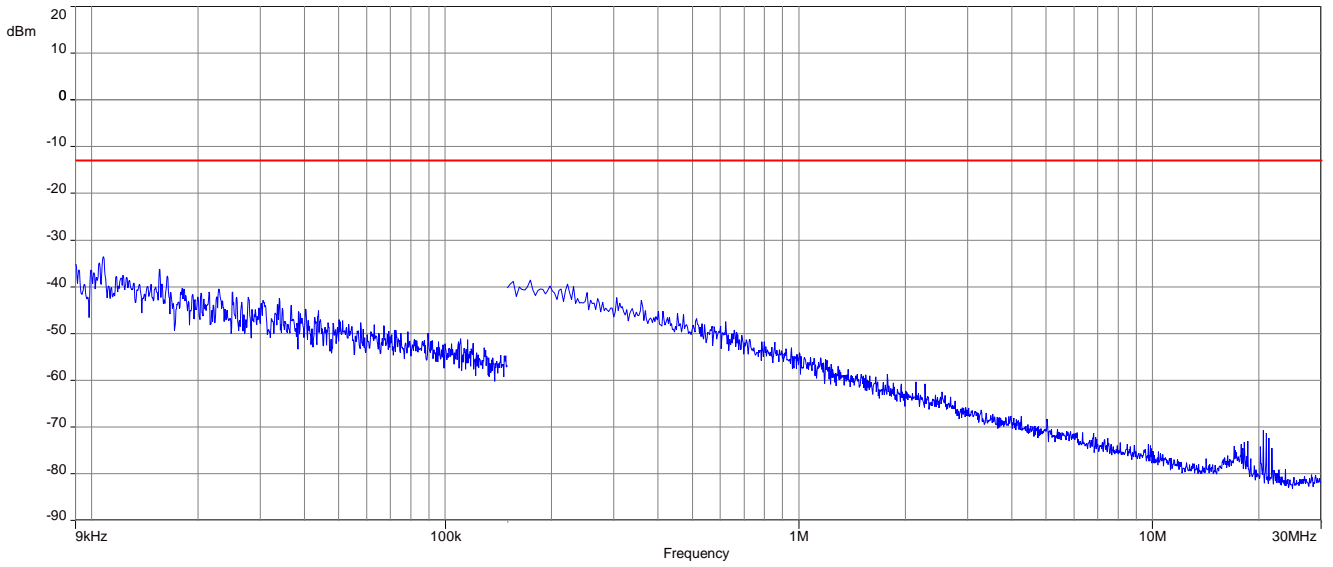

Plot 2: Channel 20525 (30 MHz – 1 GHz)

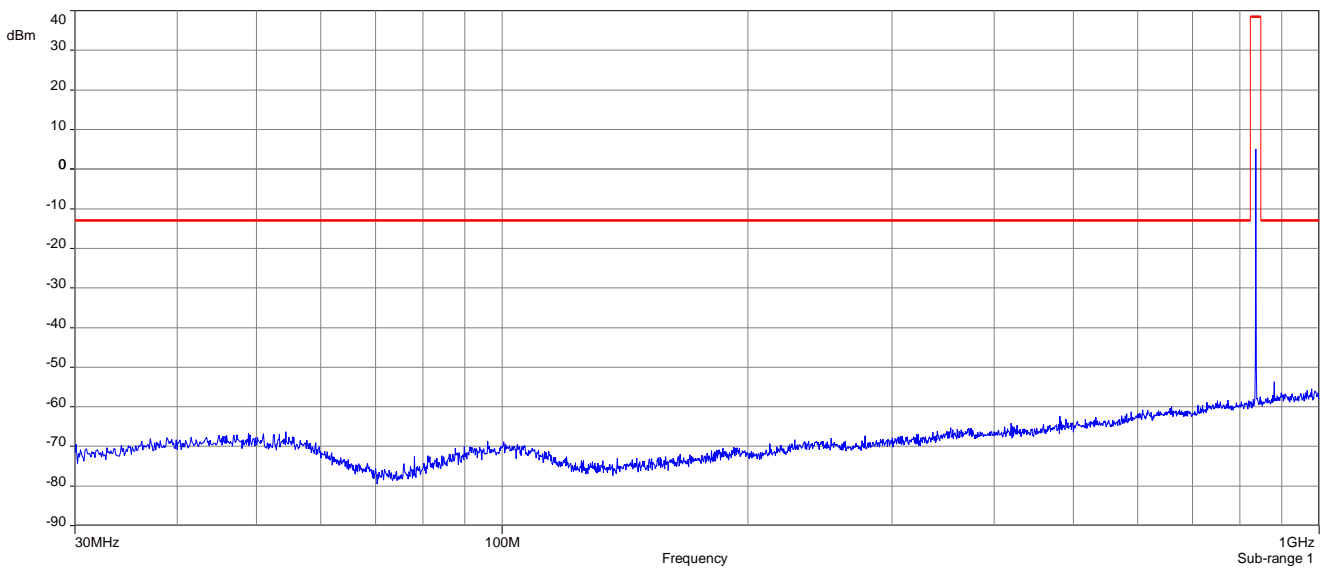

Plot 3: Channel 20525 (1 GHz – 12.75 GHz)

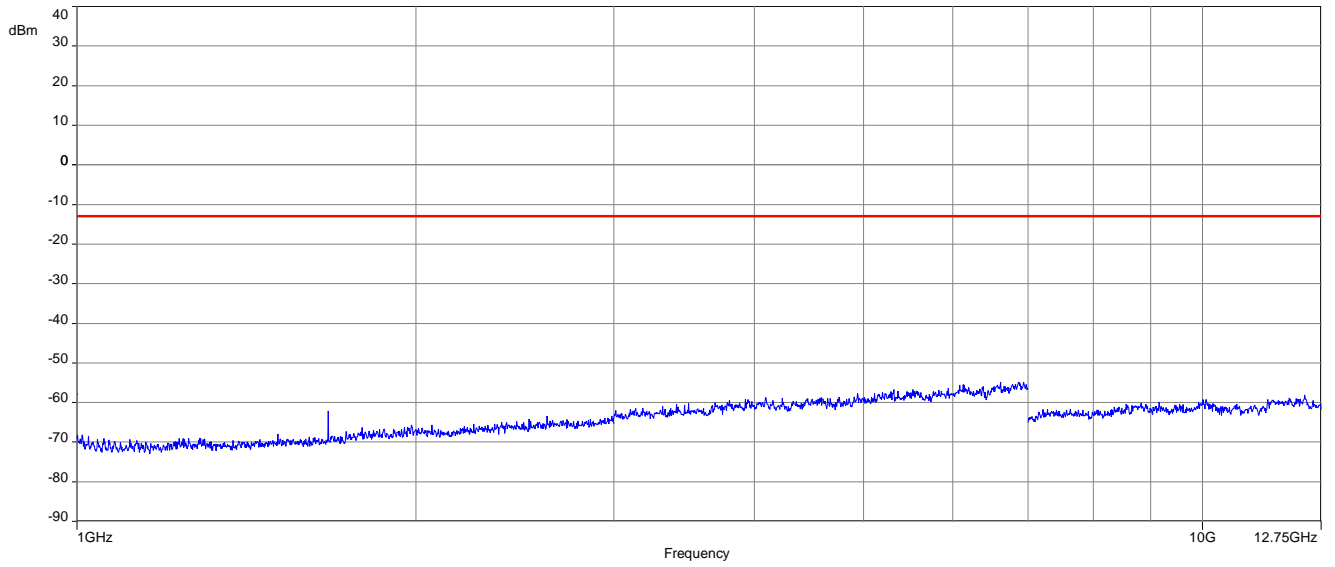

15 RF measurements LTE band 26

15.1 Description of test setup

For the spurious measurements we use the substitution method according TIA/EIA 603.

15.2 Results

The EUT was set to transmit the maximum power.

15.2.1 RF output power

Description:

This paragraph contains conducted average power, ERP and Peak-to-Average Power Ratio measurements for the mobile station.

Measurement:

The mobile was set up for the maximum output power with pseudo random data modulation.

Measurement parameters	
Setup	See chapter 7.1 – A
Measurement uncertainty	See chapter 9

Limits:

FCC
Nominal Peak Output Power
+38.45 dBm (FCC) / +33 dBm (IC)
In measuring transmissions in this band using an average power technique, the peak-to-average ratio (PAR) of the transmission may not exceed 13 dB.

Results: Cat M1

Output Power (radiated)			
Bandwidth and RB settings	Frequency (MHz)	Average Output Power (dBm) QPSK	Average Output Power (dBm) 16QAM
1.4 MHz 1#0	814.7	19.2	19.2
1.4 MHz 1#0	819.0	19.1	19.2
1.4 MHz 1#5	823.3	18.9	19.0
1.4 MHz 1#0	824.7	18.8	18.9
1.4 MHz 1#0	836.5	19.4	18.0
1.4 MHz 1#5	848.3	19.2	18.2

15.2.2 Spurious emissions radiated

Description:

The following steps outline the procedure used to measure the radiated emissions from the mobile station. The site is constructed in accordance with ANSI C63.4:2014 requirements and is recognized by the FCC to be in compliance for a 3 and a 10 meter site. The spectrum was scanned from 30 MHz to the 10th harmonic of the highest frequency generated within the equipment, which is the transmitted carrier that can be as high as 848,3 MHz. Measurement made up to 12.75 GHz. The resolution bandwidth is set as outlined in Part 22.917. The spectrum was scanned with the mobile station transmitting at carrier frequencies that pertain to low, mid and high channels of the LTE band 26.

Measurement:

Measurement parameters	
Detector	Peak
Sweep time	2 sec.
Video bandwidth	Below 1 GHz: 100 kHz Above 1 GHz: 1 MHz
Resolution bandwidth	Below 1 GHz: 100 kHz Above 1 GHz: 1 MHz
Span	100 MHz Steps
Trace mode	Max Hold
Setup	See chapter 7.1 - A; 7.2 - B&C
Measurement uncertainty	See chapter 9

Limits:

FCC
Spurious Emissions Radiated
Attenuation $\geq 43 + 10\log(P) / (P, \text{Power in Watts})$
-13 dBm

Cat M1

Spurious Emission Level (dBm)								
Harmonic	Lowest channel Freq. (MHz)	Level [dBm]	Harmonic	Middle channel Freq. (MHz)	Level [dBm]	Harmonic	Highest channel Freq. (MHz)	Level [dBm]
2	1658.0	All detected emissions are more than 20dB below the limit!	2	1673.0	All detected emissions are more than 20dB below the limit!	2	1688.0	All detected emissions are more than 20dB below the limit!
3	2487.0		3	2509.5		3	2532.0	
4	3316.0		4	3346.0		4	3376.0	
5	4145.0		5	4182.5		5	4220.0	
6	4974.0		6	5019.0		6	5064.0	
7	5803.0		7	5855.5		7	5908.0	
8	6632.0		8	6692.0		8	6752.0	
9	7461.0		9	7528.5		9	7596.0	
10	8290.0		10	8365.0		10	8440.0	

Results: Cat M1

Plot 1: Channel 20525 (Traffic mode up to 30 MHz)

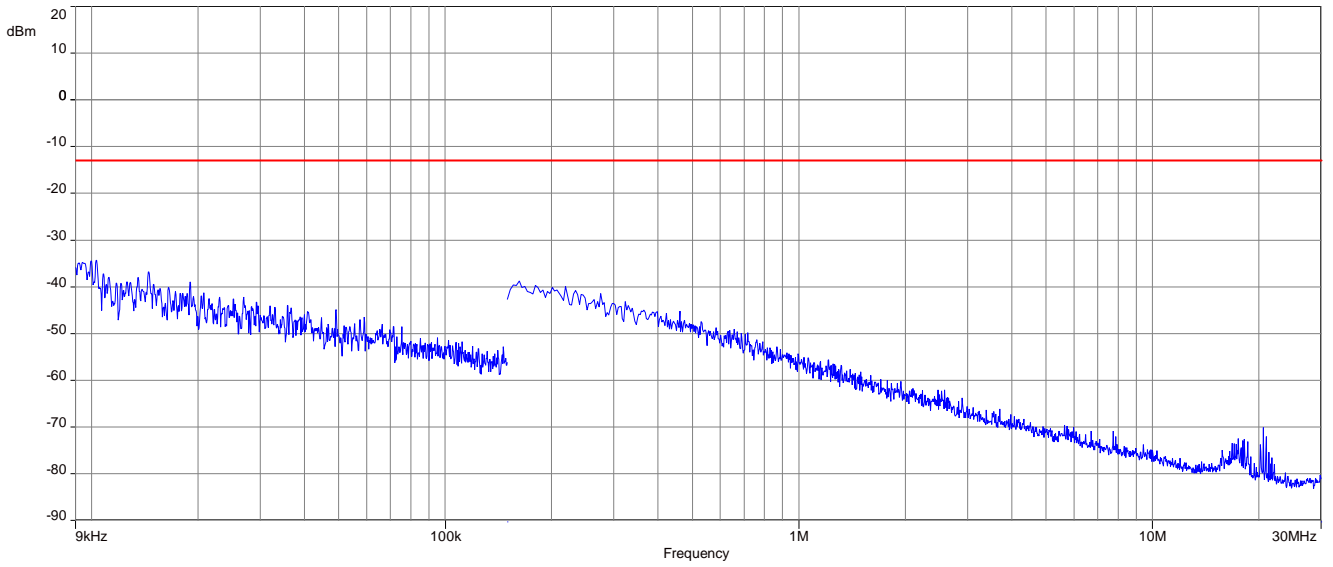

Plot 2: Channel 20525 (30 MHz – 1 GHz)

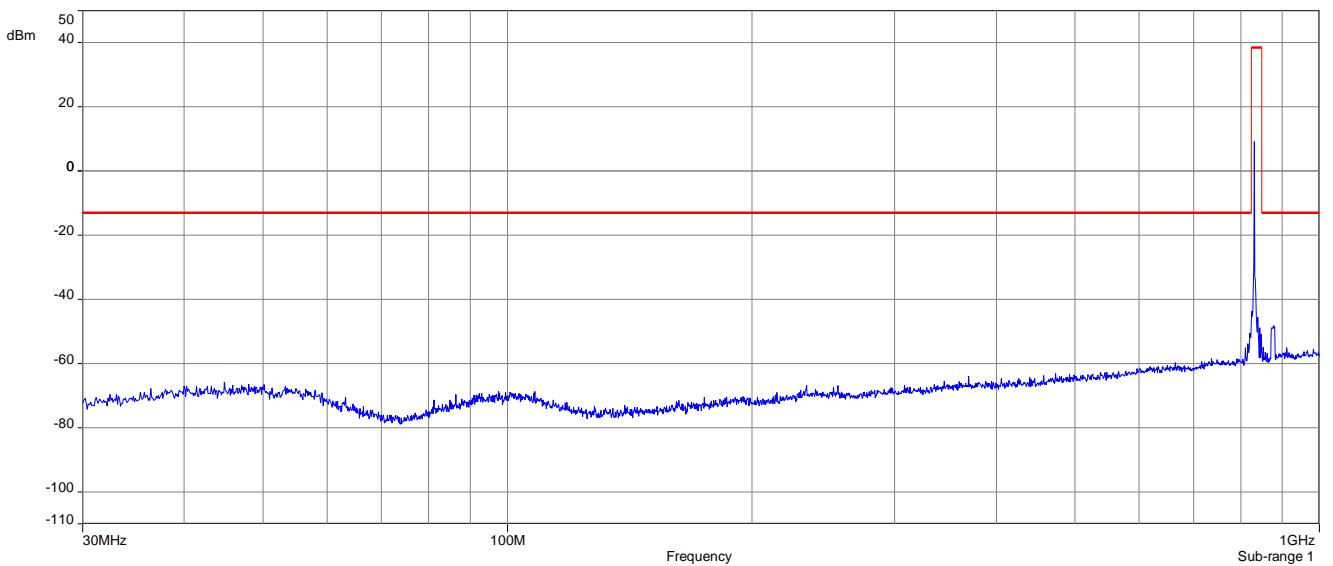

Plot 3: Channel 20525 (1 GHz – 12.75 GHz)

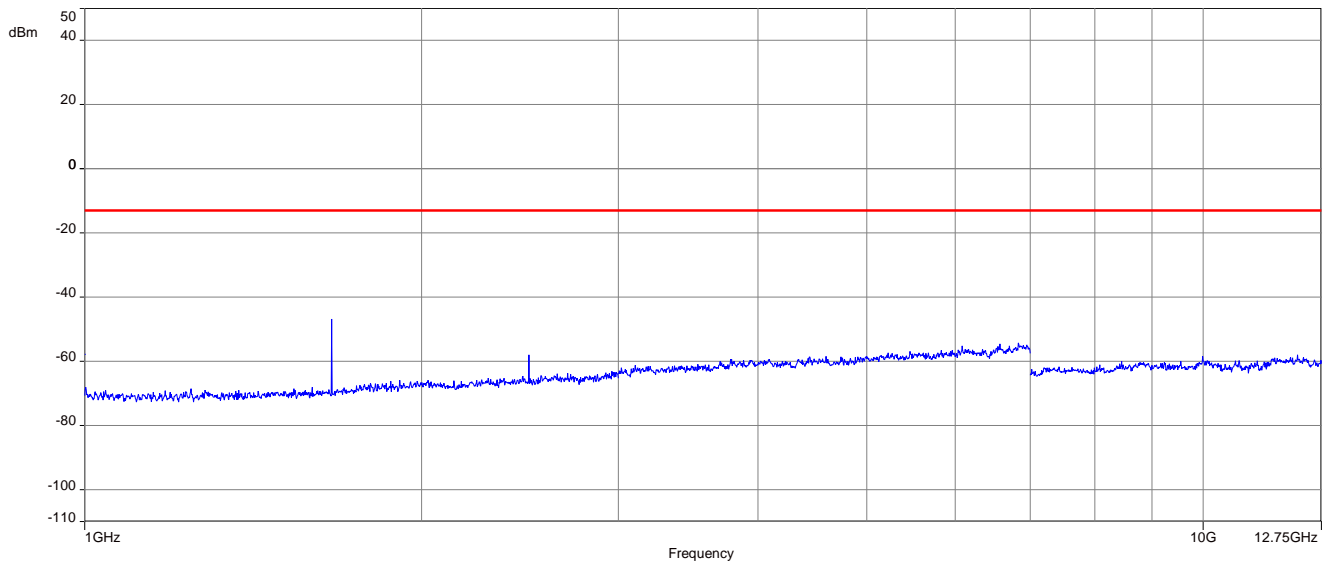

16 Summary of measurement results LTE band 4, 12, 13, 66, 71 & 85

<input type="checkbox"/>	No deviations from the technical specifications were ascertained
<input type="checkbox"/>	There were deviations from the technical specifications ascertained
<input checked="" type="checkbox"/>	This test report is only a partial test report. The content and verdict of the performed test cases are listed below.

TC identifier	Description	verdict	date	Remark
RF-Testing	CFR Part 27 RSS-130, RSS 139, RSS-199	See table!	2021-08-06	Delta tests according to manufacturer demand!

16.1 LTE – Band 4

Test Case	temperature conditions	power source voltages	C	NC	NA	NP	Remark
RF Output Power	Nominal	Nominal	<input type="checkbox"/>	<input type="checkbox"/>	<input type="checkbox"/>	<input checked="" type="checkbox"/>	-/-
Frequency Stability	Extreme	Extreme	<input type="checkbox"/>	<input type="checkbox"/>	<input type="checkbox"/>	<input checked="" type="checkbox"/>	-/-
Spurious Emissions Radiated	Nominal	Nominal	<input checked="" type="checkbox"/>	<input type="checkbox"/>	<input type="checkbox"/>	<input type="checkbox"/>	-/-
Spurious Emissions Conducted	Nominal	Nominal	<input type="checkbox"/>	<input type="checkbox"/>	<input type="checkbox"/>	<input checked="" type="checkbox"/>	-/-
Block Edge Compliance	Nominal	Nominal	<input type="checkbox"/>	<input type="checkbox"/>	<input type="checkbox"/>	<input checked="" type="checkbox"/>	-/-
Occupied Bandwidth	Nominal	Nominal	<input type="checkbox"/>	<input type="checkbox"/>	<input type="checkbox"/>	<input checked="" type="checkbox"/>	-/-

Notes:

C	Compliant	NC	Not compliant	NA	Not applicable	NP	Not performed
----------	-----------	-----------	---------------	-----------	----------------	-----------	---------------

16.2 LTE – Band 12

Test Case	temperature conditions	power source voltages	C	NC	NA	NP	Remark
RF Output Power	Nominal	Nominal	<input checked="" type="checkbox"/>	<input type="checkbox"/>	<input type="checkbox"/>	<input type="checkbox"/>	-/-
Frequency Stability	Extreme	Extreme	<input type="checkbox"/>	<input type="checkbox"/>	<input type="checkbox"/>	<input checked="" type="checkbox"/>	-/-
Spurious Emissions Radiated	Nominal	Nominal	<input checked="" type="checkbox"/>	<input type="checkbox"/>	<input type="checkbox"/>	<input type="checkbox"/>	-/-
Spurious Emissions Conducted	Nominal	Nominal	<input type="checkbox"/>	<input type="checkbox"/>	<input type="checkbox"/>	<input checked="" type="checkbox"/>	-/-
Block Edge Compliance	Nominal	Nominal	<input type="checkbox"/>	<input type="checkbox"/>	<input type="checkbox"/>	<input checked="" type="checkbox"/>	-/-
Occupied Bandwidth	Nominal	Nominal	<input type="checkbox"/>	<input type="checkbox"/>	<input type="checkbox"/>	<input checked="" type="checkbox"/>	-/-

Notes:

C	Compliant	NC	Not compliant	NA	Not applicable	NP	Not performed
----------	-----------	-----------	---------------	-----------	----------------	-----------	---------------

16.3 LTE – Band 13

Test Case	temperature conditions	power source voltages	C	NC	NA	NP	Remark
RF Output Power	Nominal	Nominal	<input checked="" type="checkbox"/>	<input type="checkbox"/>	<input type="checkbox"/>	<input type="checkbox"/>	-/-
Frequency Stability	Extreme	Extreme	<input type="checkbox"/>	<input type="checkbox"/>	<input type="checkbox"/>	<input checked="" type="checkbox"/>	-/-
Spurious Emissions Radiated	Nominal	Nominal	<input checked="" type="checkbox"/>	<input type="checkbox"/>	<input type="checkbox"/>	<input type="checkbox"/>	-/-
Spurious Emissions Conducted	Nominal	Nominal	<input type="checkbox"/>	<input type="checkbox"/>	<input type="checkbox"/>	<input checked="" type="checkbox"/>	-/-
Block Edge Compliance	Nominal	Nominal	<input type="checkbox"/>	<input type="checkbox"/>	<input type="checkbox"/>	<input checked="" type="checkbox"/>	-/-
Occupied Bandwidth	Nominal	Nominal	<input type="checkbox"/>	<input type="checkbox"/>	<input type="checkbox"/>	<input checked="" type="checkbox"/>	-/-

Notes:

C	Compliant	NC	Not compliant	NA	Not applicable	NP	Not performed
----------	-----------	-----------	---------------	-----------	----------------	-----------	---------------

16.4 LTE – Band 66

Test Case	temperature conditions	power source voltages	C	NC	NA	NP	Remark
RF Output Power	Nominal	Nominal	<input checked="" type="checkbox"/>	<input type="checkbox"/>	<input type="checkbox"/>	<input type="checkbox"/>	-/-
Frequency Stability	Extreme	Extreme	<input type="checkbox"/>	<input type="checkbox"/>	<input type="checkbox"/>	<input checked="" type="checkbox"/>	-/-
Spurious Emissions Radiated	Nominal	Nominal	<input checked="" type="checkbox"/>	<input type="checkbox"/>	<input type="checkbox"/>	<input type="checkbox"/>	-/-
Spurious Emissions Conducted	Nominal	Nominal	<input type="checkbox"/>	<input type="checkbox"/>	<input type="checkbox"/>	<input checked="" type="checkbox"/>	-/-
Block Edge Compliance	Nominal	Nominal	<input type="checkbox"/>	<input type="checkbox"/>	<input type="checkbox"/>	<input checked="" type="checkbox"/>	-/-
Occupied Bandwidth	Nominal	Nominal	<input type="checkbox"/>	<input type="checkbox"/>	<input type="checkbox"/>	<input checked="" type="checkbox"/>	-/-

Notes:

C	Compliant	NC	Not compliant	NA	Not applicable	NP	Not performed
----------	-----------	-----------	---------------	-----------	----------------	-----------	---------------

16.5 LTE – Band 71

Test Case	temperature conditions	power source voltages	C	NC	NA	NP	Remark
RF Output Power	Nominal	Nominal	<input checked="" type="checkbox"/>	<input type="checkbox"/>	<input type="checkbox"/>	<input type="checkbox"/>	-/-
Frequency Stability	Extreme	Extreme	<input type="checkbox"/>	<input type="checkbox"/>	<input type="checkbox"/>	<input checked="" type="checkbox"/>	-/-
Spurious Emissions Radiated	Nominal	Nominal	<input checked="" type="checkbox"/>	<input type="checkbox"/>	<input type="checkbox"/>	<input type="checkbox"/>	-/-
Spurious Emissions Conducted	Nominal	Nominal	<input type="checkbox"/>	<input type="checkbox"/>	<input type="checkbox"/>	<input checked="" type="checkbox"/>	-/-
Block Edge Compliance	Nominal	Nominal	<input type="checkbox"/>	<input type="checkbox"/>	<input type="checkbox"/>	<input checked="" type="checkbox"/>	-/-
Occupied Bandwidth	Nominal	Nominal	<input type="checkbox"/>	<input type="checkbox"/>	<input type="checkbox"/>	<input checked="" type="checkbox"/>	-/-

Notes:

C	Compliant	NC	Not compliant	NA	Not applicable	NP	Not performed
----------	-----------	-----------	---------------	-----------	----------------	-----------	---------------

16.6 LTE – Band 85

Test Case	temperature conditions	power source voltages	C	NC	NA	NP	Remark
RF Output Power	Nominal	Nominal	<input checked="" type="checkbox"/>	<input type="checkbox"/>	<input type="checkbox"/>	<input type="checkbox"/>	-/-
Frequency Stability	Extreme	Extreme	<input type="checkbox"/>	<input type="checkbox"/>	<input type="checkbox"/>	<input checked="" type="checkbox"/>	-/-
Spurious Emissions Radiated	Nominal	Nominal	<input checked="" type="checkbox"/>	<input type="checkbox"/>	<input type="checkbox"/>	<input type="checkbox"/>	-/-
Spurious Emissions Conducted	Nominal	Nominal	<input type="checkbox"/>	<input type="checkbox"/>	<input type="checkbox"/>	<input checked="" type="checkbox"/>	-/-
Block Edge Compliance	Nominal	Nominal	<input type="checkbox"/>	<input type="checkbox"/>	<input type="checkbox"/>	<input checked="" type="checkbox"/>	-/-
Occupied Bandwidth	Nominal	Nominal	<input type="checkbox"/>	<input type="checkbox"/>	<input type="checkbox"/>	<input checked="" type="checkbox"/>	-/-

Notes:

C	Compliant	NC	Not compliant	NA	Not applicable	NP	Not performed
----------	-----------	-----------	---------------	-----------	----------------	-----------	---------------

17 RF measurements

17.1 Description of test setup

For the spurious measurements we use the substitution method according TIA/EIA 603.

17.2 Results LTE – Band 4

The EUT was set to transmit the maximum power.

17.2.1 RF output power

Description:

This paragraph contains average power, peak output power and EIRP measurements for the mobile station. In all cases, the peak output power is within the required mask (this mask is specified in the JTC standards, TIA PN3389 Vol. 1 Chap 7, and is no FCC requirement).

Measurement:

The mobile was set up for the maximum output power with pseudo random data modulation.

Measurement parameters	
Setup	See chapter 7.2 – A
Measurement uncertainty	See chapter 9

Limits:

FCC	ISED
Max Output Power	
+30.00 dBm	
In measuring transmissions in this band using an average power technique, the peak-to-average ratio (PAR) of the transmission may not exceed 13 dB.	

Results: Cat M1

Output Power (radiated)			
Bandwidth and RB settings	Frequency (MHz)	Average Output Power (dBm) QPSK	Average Output Power (dBm) 16QAM
1.4 MHz 1#0	1710.7	17.0	16.0
1.4 MHz 1#0	1732.5	16.8	15.8
1.4 MHz 1#5	1754.3	16.1	16.0

Results: NB-IOT2

Output Power (radiated)			
Settings	Frequency (MHz)	Average Output Power (dBm) BPSK	Average Output Power (dBm) QPSK
15 kHz sub-carrier spacing	1710.7	18.3	18.3
15 kHz sub-carrier spacing	1732.5	18.3	18.3
15 kHz sub-carrier spacing	1754.3	18.3	18.3

17.2.2 Spurious emissions radiated

Description:

The following steps outline the procedure used to measure the radiated emissions from the mobile station. The site is constructed in accordance with ANSI C63.4:2014 requirements and is recognized by the FCC to be in compliance for a 3 and a 10 meter site. The spectrum was scanned from 30 MHz to the 10th harmonic of the highest frequency generated within the equipment, which is the transmitted carrier that can be as high as 1755 MHz. Measurement made up to 26 GHz. The resolution bandwidth is set as outlined in Part 27.53. The spectrum was scanned with the mobile station transmitting at carrier frequencies that pertain to low, mid and high channels of the LTE band 4.

Measurement:

Measurement parameters	
Detector	Peak
Sweep time	2 sec.
Video bandwidth	Below 1 GHz: 100 kHz Above 1 GHz: 1 MHz
Resolution bandwidth	Below 1 GHz: 100 kHz Above 1 GHz: 1 MHz
Span	100 MHz Steps
Trace mode	Max Hold
Setup	See chapter 7.1 - A; 7.2 – B&C; 7.3 - A
Measurement uncertainty	See chapter 9

Limits:

FCC	ISED
Spurious Emissions Radiated	
Attenuation $\geq 43 + 10\log(P) / (P, \text{Power in Watts})$	
-13 dBm	

Cat M1

Spurious Emission Level (dBm)					
Lowest channel		Middle channel		Highest channel	
Spurious emissions	Level [dBm]	Spurious emissions	Level [dBm]	Spurious emissions	Level [dBm]
All detected emissions are more than 20dB below the limit!					
	-		-		-
	-		-		-
	-		-		-
	-		-		-
	-		-		-
	-		-		-
	-		-		-

Cat NB2

Spurious Emission Level (dBm)					
Lowest channel		Middle channel		Highest channel	
Spurious emissions	Level [dBm]	Spurious emissions	Level [dBm]	Spurious emissions	Level [dBm]
All detected emissions are more than 20dB below the limit!					
	-		-		-
	-		-		-
	-		-		-
	-		-		-
	-		-		-
	-		-		-
	-		-		-

Results: Cat M1

Plot 1: Middle channel, up to 30 MHz

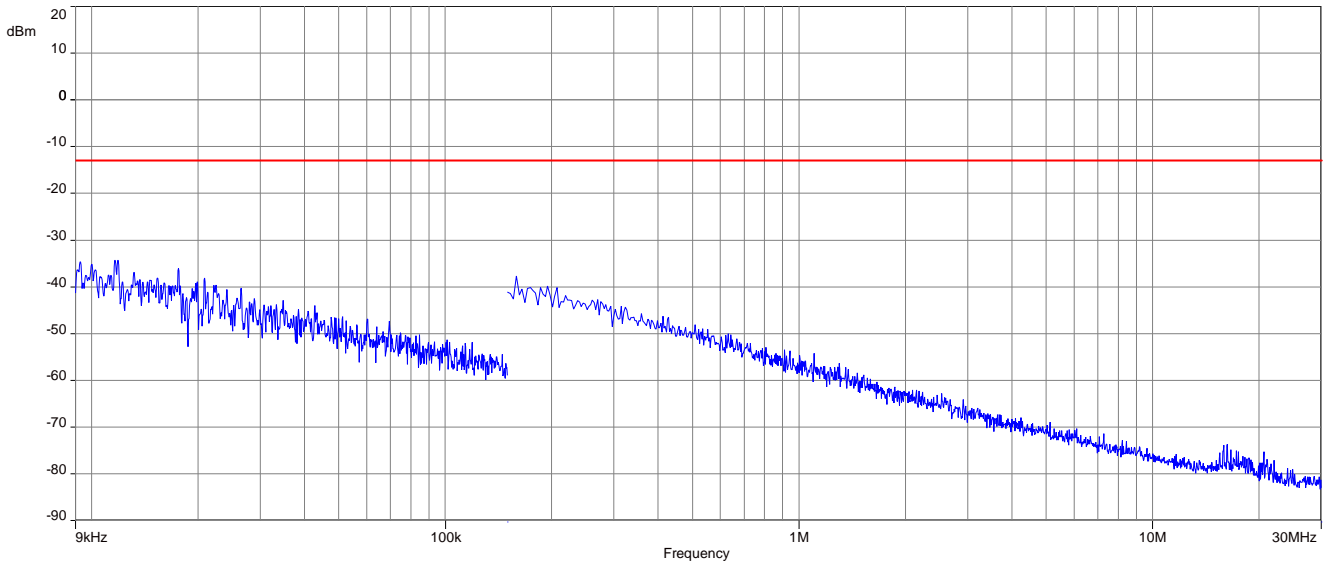

Plot 2: Middle channel, 30 MHz to 1 GHz

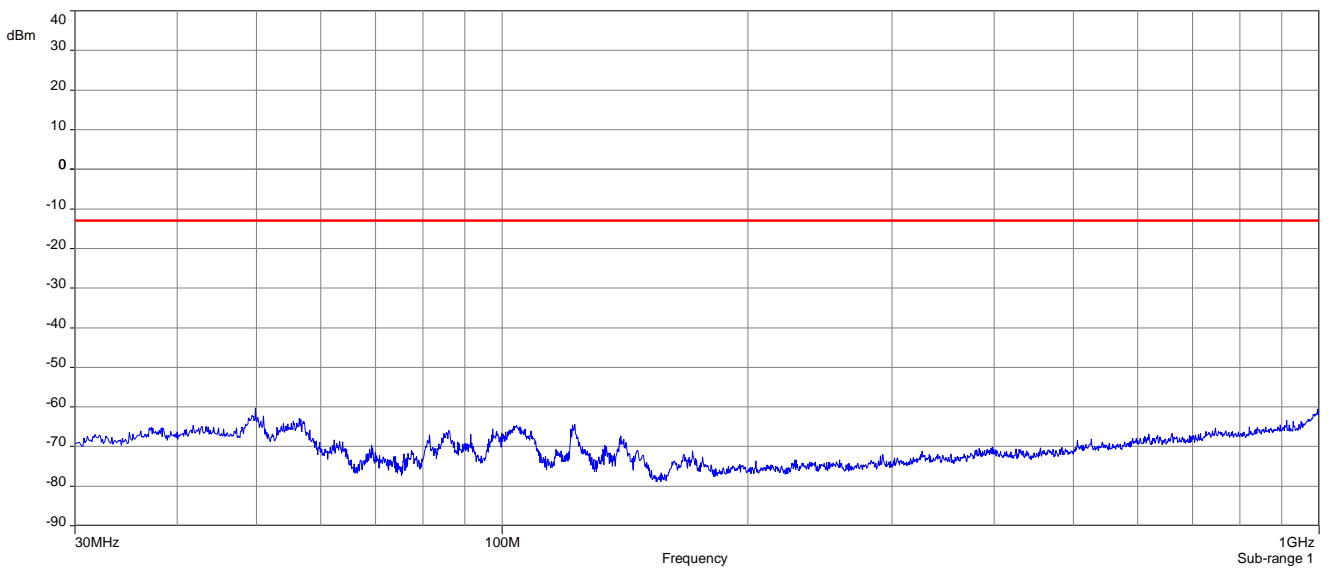

Plot 3: Middle channel, 1 GHz to 18 GHz

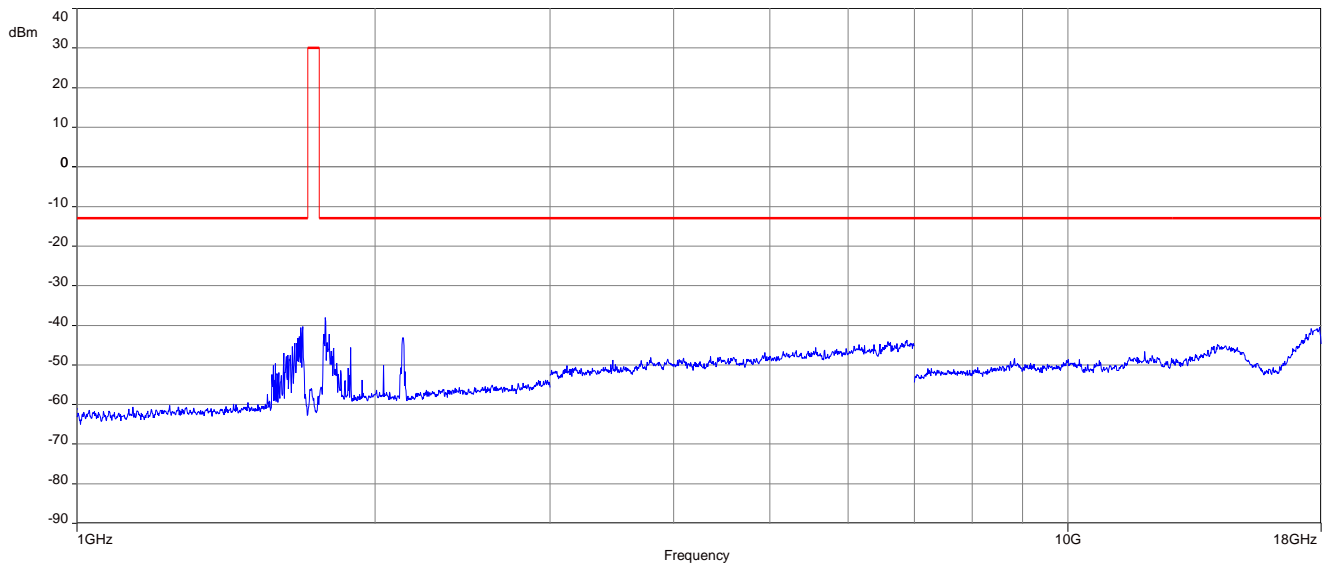

Carrier notched with 1.7 GHz rejection filter, the shown peak around 2.1 GHz is caused by the downlink signal

Results: Cat NB2

Plot 1: Middle channel, up to 30 MHz

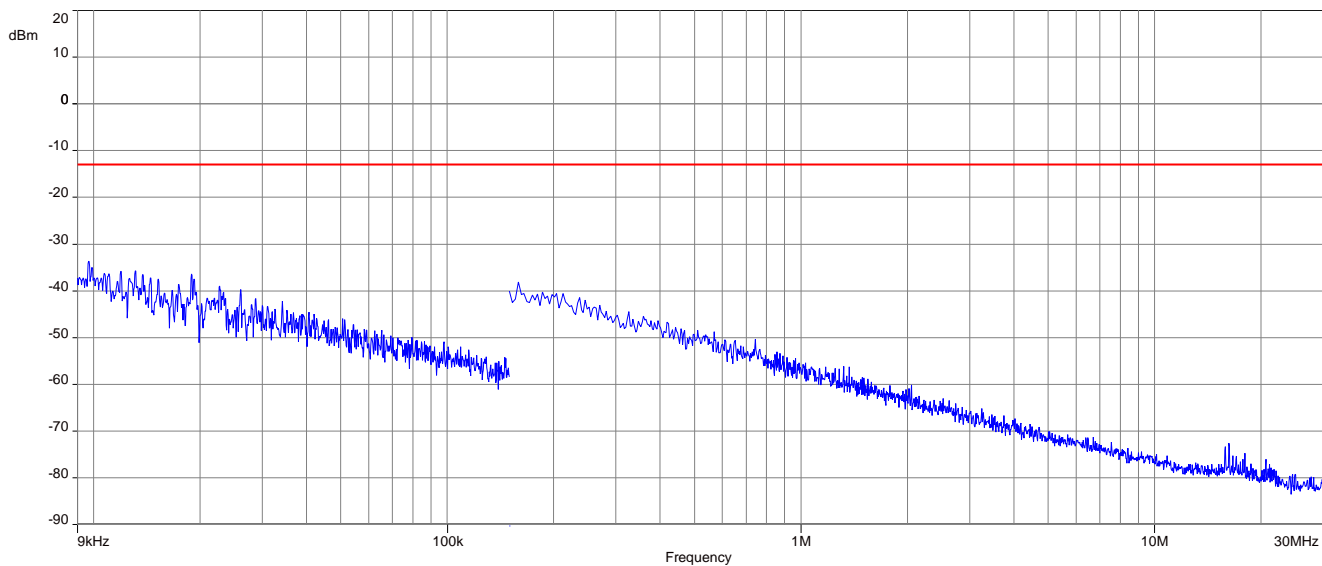

Plot 2: Middle channel, 30 MHz to 1 GHz

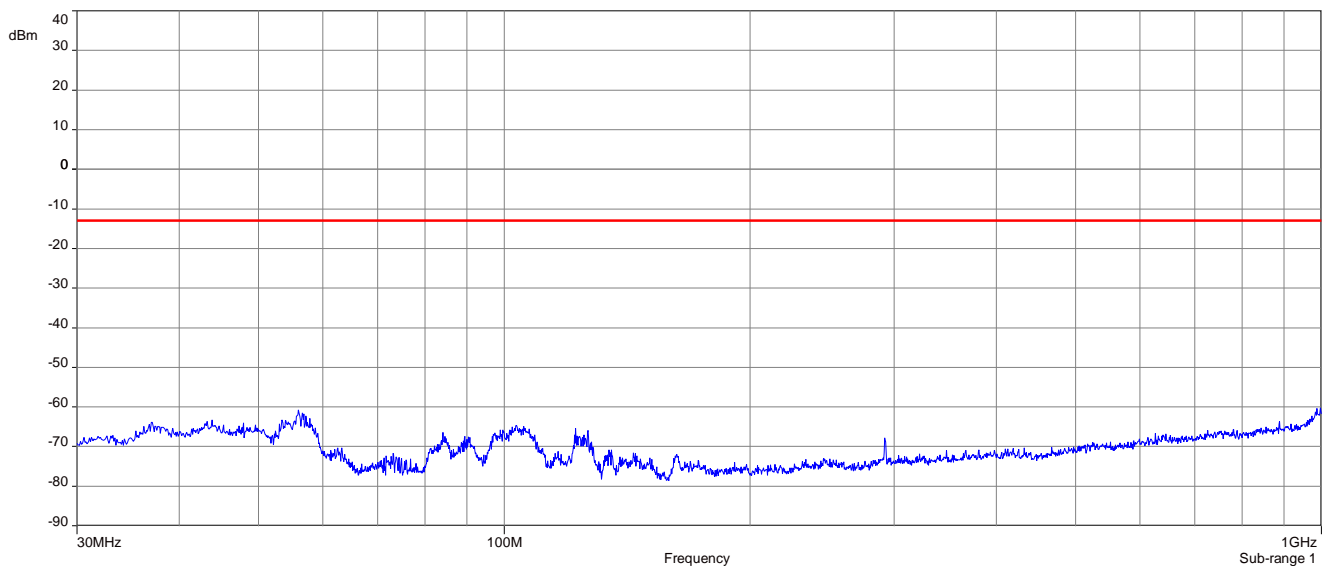

Plot 3: Middle channel, 1 GHz to 18 GHz

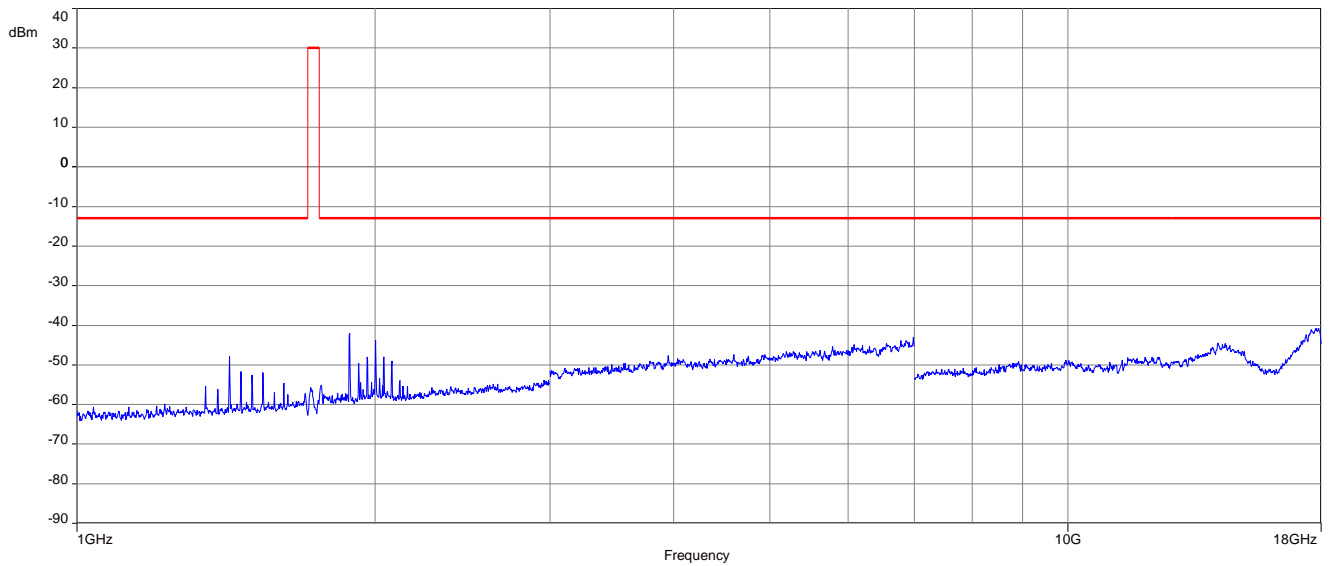

Carrier notched with 1.7 GHz rejection filter, the shown peak around 2.1 GHz is caused by the downlink signal

17.3 Results LTE – Band 12

The EUT was set to transmit the maximum power.

17.3.1 RF output power

Description:

This paragraph contains average power, peak output power and EIRP measurements for the mobile station. In all cases, the peak output power is within the required mask (this mask is specified in the JTC standards, TIA PN3389 Vol. 1 Chap 7, and is no FCC requirement).

Measurement:

The mobile was set up for the maximum output power with pseudo random data modulation.

Measurement parameters	
Setup	See chapter 7.1 – A
Measurement uncertainty	See chapter 9

Limits:

FCC	ISED
Max Output Power	
+34.77 dBm	
In measuring transmissions in this band using an average power technique, the peak-to-average ratio (PAR) of the transmission may not exceed 13 dB.	

Results: Cat M1

Output Power (radiated)			
Bandwidth and RB settings	Frequency (MHz)	Average Output Power (dBm) QPSK	Average Output Power (dBm) 16QAM
1.4 MHz 1#0	699.7	14.5	14.3
1.4 MHz 1#0	707.5	14.4	14.2
1.4 MHz 1#5	715.3	15.0	13.8

Results: NB-IOT2

Output Power (radiated)			
Settings	Frequency (MHz)	Average Output Power (dBm) BPSK	Average Output Power (dBm) QPSK
15 kHz sub-carrier spacing	699.2	15.2	15.0
15 kHz sub-carrier spacing	707.5	15.2	15.1
15 kHz sub-carrier spacing	715.8	15.2	15.2

17.3.2 Spurious emissions radiated

Description:

The following steps outline the procedure used to measure the radiated emissions from the mobile station. The site is constructed in accordance with ANSI C63.4:2014 requirements and is recognized by the FCC to be in compliance for a 3 and a 10 meter site. The spectrum was scanned from 30 MHz to the 10th harmonic of the highest frequency generated within the equipment, which is the transmitted carrier that can be as high as 715.3 MHz. This was rounded up to 8 GHz. The resolution bandwidth is set as outlined in Part 27.53. The spectrum was scanned with the mobile station transmitting at carrier frequencies that pertain to low, mid and high channels of the LTE band 12.

Measurement:

Measurement parameters	
Detector	Peak
Sweep time	2 sec.
Video bandwidth	Below 1 GHz: 100 kHz Above 1 GHz: 1 MHz
Resolution bandwidth	Below 1 GHz: 100 kHz Above 1 GHz: 1 MHz
Span	100 MHz Steps
Trace mode	Max Hold
Setup	See chapter 7.1 - A; 7.2 – B&C
Measurement uncertainty	See chapter 9

Limits:

FCC	ISED
Spurious Emissions Radiated	
Attenuation $\geq 43 + 10\log(P)$ (P, Power in Watts)	
-13 dBm and 1559 MHz to 1610 MHz with -40 dBm	

Cat M1

Spurious Emission Level (dBm)					
Lowest channel		Middle channel		Highest channel	
Spurious emissions	Level [dBm]	Spurious emissions	Level [dBm]	Spurious emissions	Level [dBm]
All detected emissions are more than 20dB below the limit!					
	-		-		-
	-		-		-
	-		-		-
	-		-		-
	-		-		-
	-		-		-
	-		-		-

Cat NB2

Spurious Emission Level (dBm)					
Lowest channel		Middle channel		Highest channel	
Spurious emissions	Level [dBm]	Spurious emissions	Level [dBm]	Spurious emissions	Level [dBm]
All detected emissions are more than 20dB below the limit!					
	-		-		-
	-		-		-
	-		-		-
	-		-		-
	-		-		-
	-		-		-
	-		-		-

Results: Cat M1

Plot 1: Middle channel, up to 30 MHz

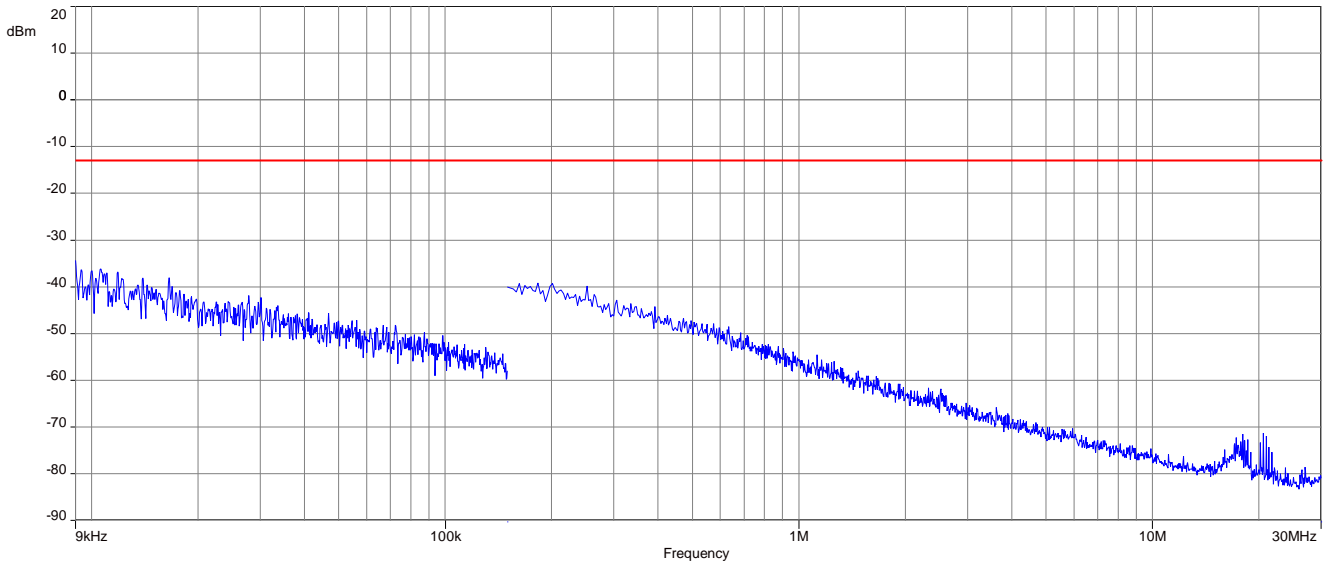

Plot 2: Middle channel, 30 MHz to 1 GHz

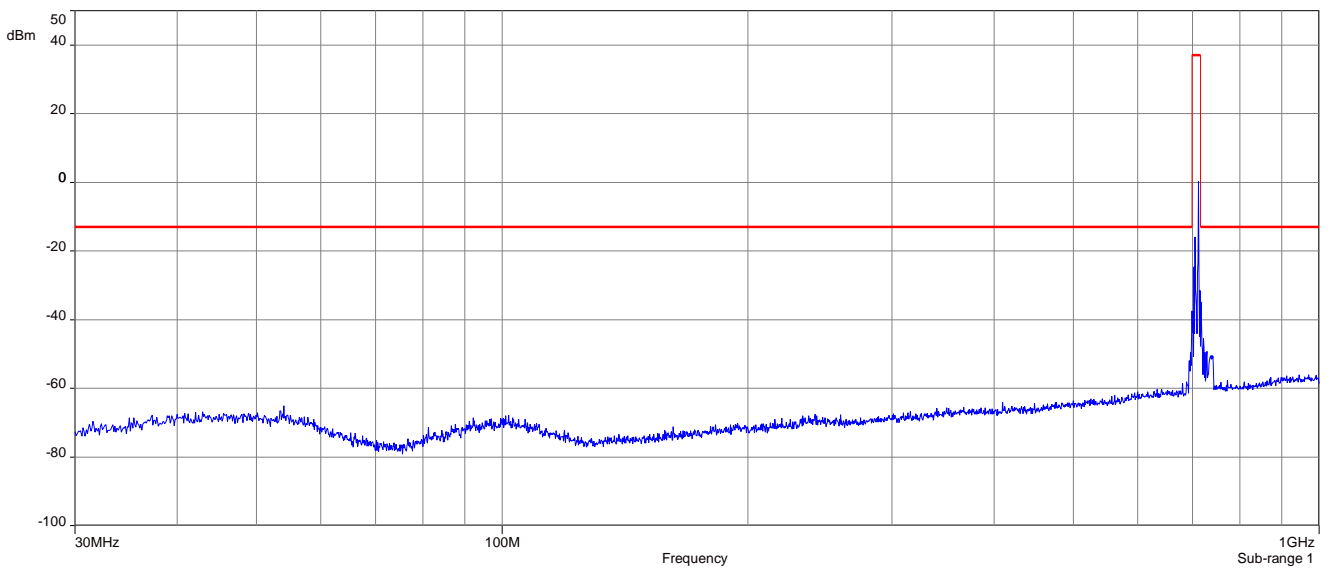

Plot 3: Middle channel, 1 GHz to 12.75 GHz

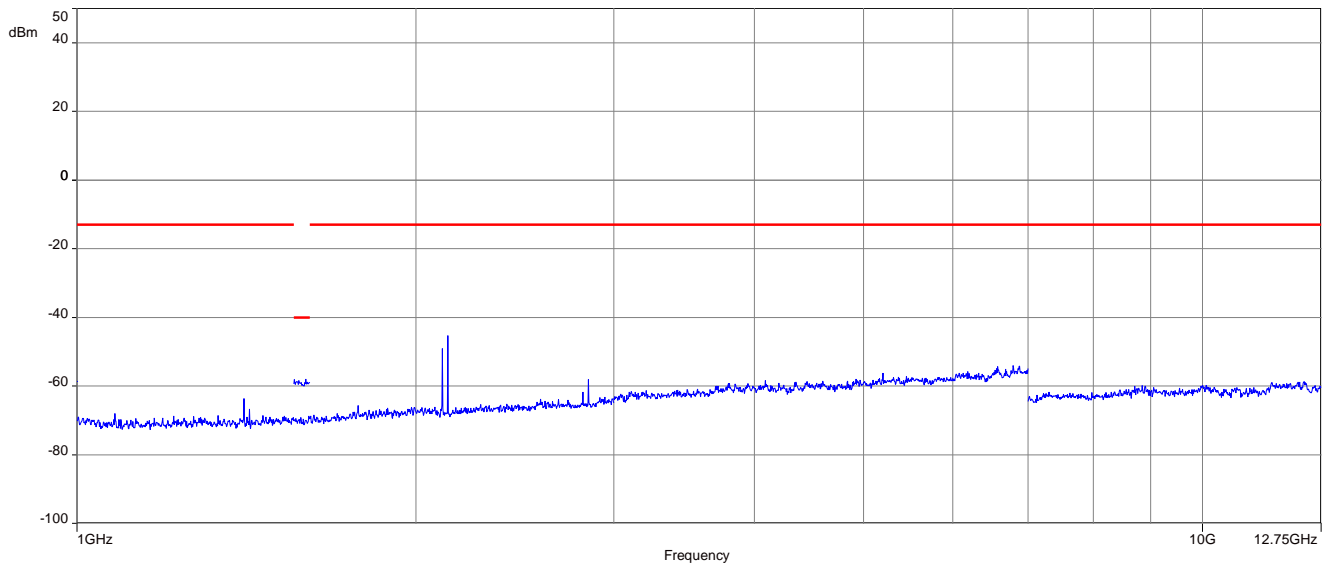

Results: Cat NB2

Plot 1: Middle channel, up to 30 MHz

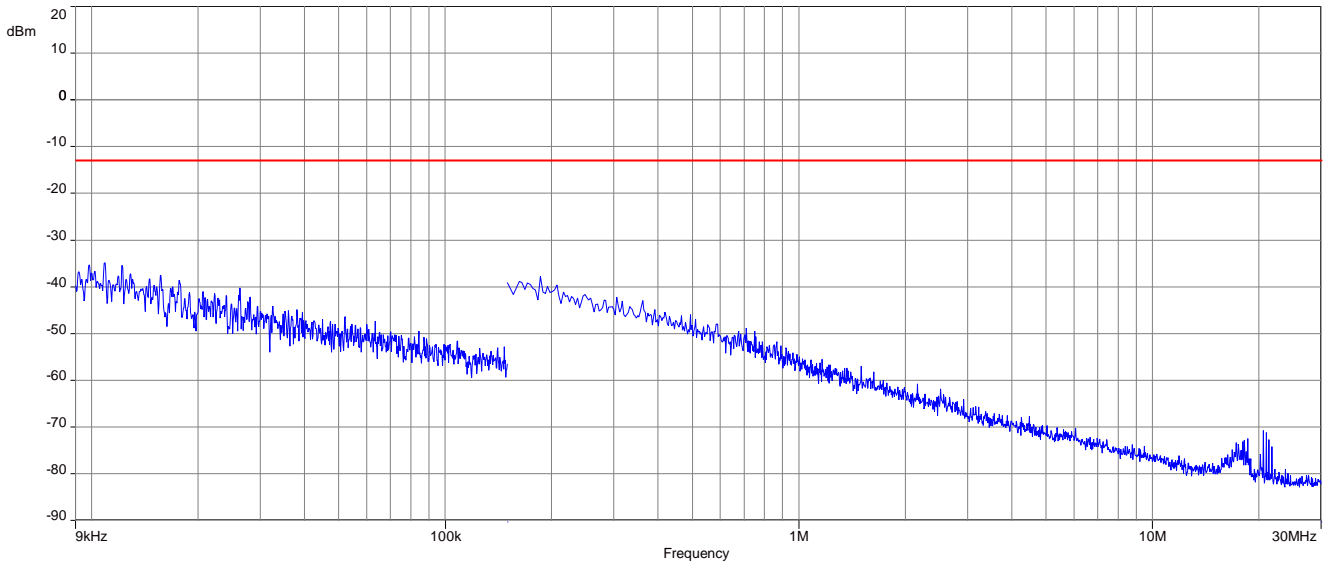

Plot 2: Middle channel, 30 MHz to 1 GHz

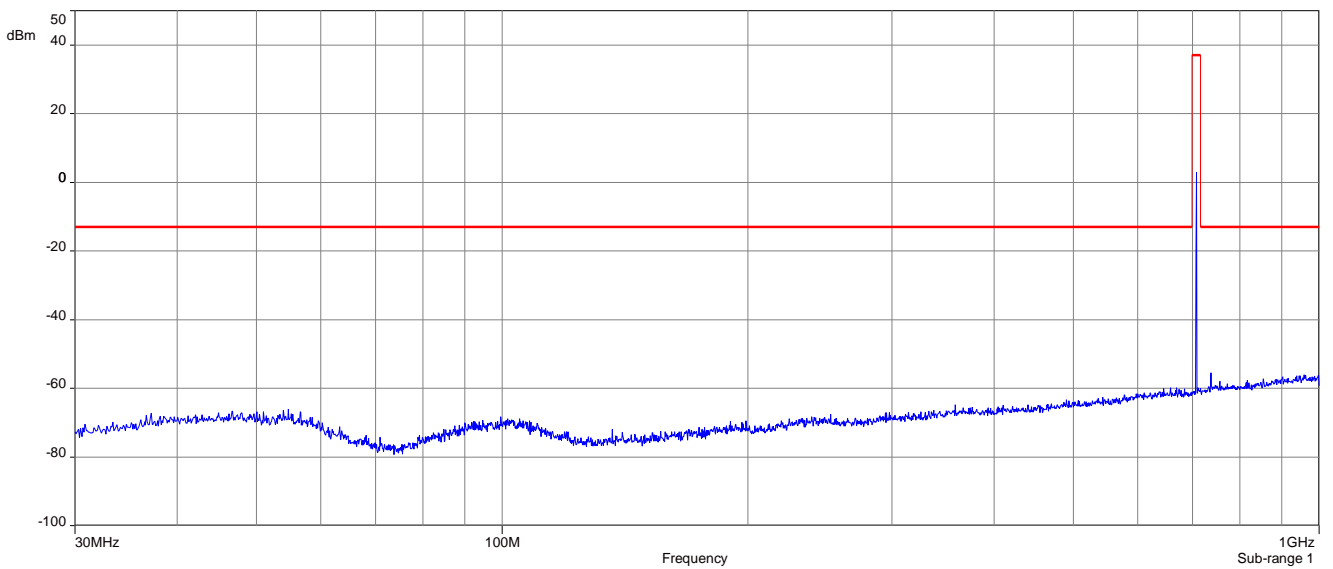

Plot 3: Middle channel, 1 GHz to 12.75 GHz

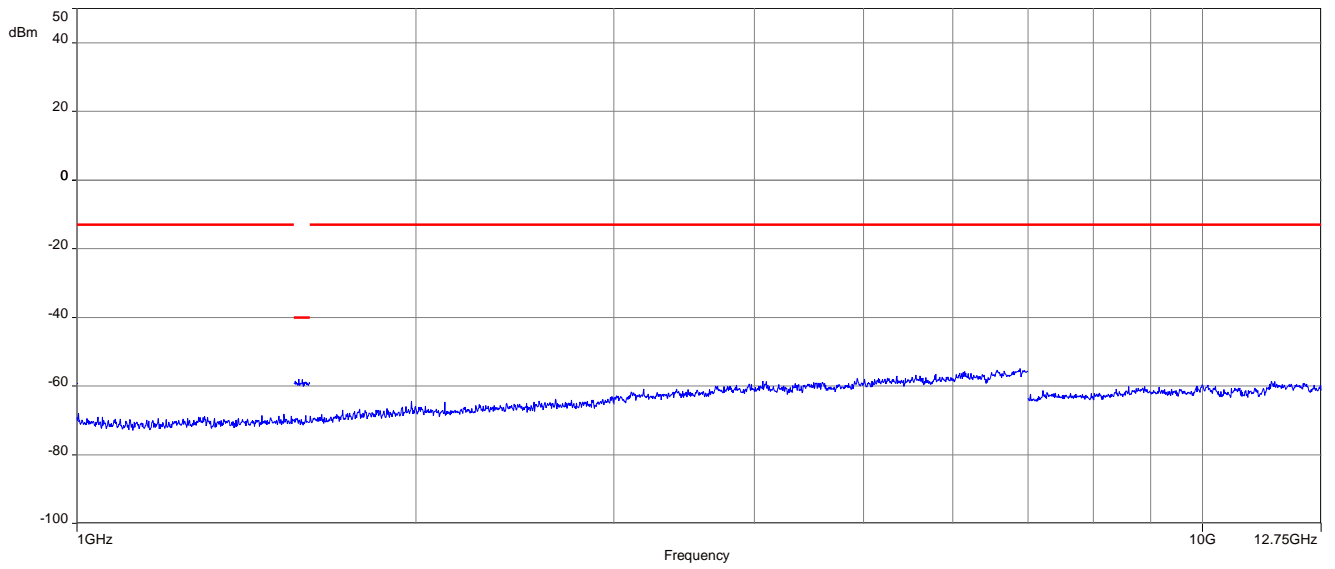

17.4 Results LTE – Band 13

The EUT was set to transmit the maximum power.

17.4.1 RF output power

Description:

This paragraph contains average power, peak output power and EIRP measurements for the mobile station. In all cases, the peak output power is within the required mask (this mask is specified in the JTC standards, TIA PN3389 Vol. 1 Chap 7, and is no FCC requirement).

Measurement:

The mobile was set up for the maximum output power with pseudo random data modulation.

Measurement parameters	
Setup	See chapter 7.1 – A
Measurement uncertainty	See chapter 9

Limits:

FCC	ISED
Nominal Peak Output Power	
+34.77 dBm	
In measuring transmissions in this band using an average power technique, the peak-to-average ratio (PAR) of the transmission may not exceed 13 dB.	

Results: Cat M1

Output Power (radiated)			
Bandwidth and RB settings	Frequency (MHz)	Average Output Power (dBm) QPSK	Average Output Power (dBm) 16QAM
1.4 MHz 1#0	779.5	14.0	14.3
1.4 MHz 1#0	782.0	14.1	13.8
1.4 MHz 1#5	784.5	13.8	14.2

Results: NB-IOT2

Output Power (radiated)			
Settings	Frequency (MHz)	Average Output Power (dBm) BPSK	Average Output Power (dBm) QPSK
15 kHz sub-carrier spacing	779.5	14.3	14.2
15 kHz sub-carrier spacing	782.0	14.4	14.3
15 kHz sub-carrier spacing	784.5	14.3	14.3

17.4.2 Spurious emissions radiated

Description:

The following steps outline the procedure used to measure the radiated emissions from the mobile station. The site is constructed in accordance with ANSI C63.4:2014 requirements and is recognized by the FCC to be in compliance for a 3 and a 10 meter site. The spectrum was scanned from 30 MHz to the 10th harmonic of the highest frequency generated within the equipment, which is the transmitted carrier that can be as high as 784.5 MHz. Measured up to 12.75 GHz. The resolution bandwidth is set as outlined in Part 27.53. The spectrum was scanned with the mobile station transmitting at carrier frequencies that pertain to low, mid and high channels of the LTE band 13.

Measurement:

Measurement parameters	
Detector	Peak
Sweep time	2 sec.
Video bandwidth	Below 1 GHz: 100 kHz Above 1 GHz: 1 MHz
Resolution bandwidth	Below 1 GHz: 100 kHz Above 1 GHz: 1 MHz
Span	100 MHz Steps
Trace mode	Max Hold
Setup	See chapter 7.1 - A; 7.2 – B&C
Measurement uncertainty	See chapter 9

Limits:

FCC	ISED
Spurious Emissions Radiated	
Attenuation $\geq 43 + 10\log(P)$ (P, Power in Watts)	
-13 dBm	

Cat M1

Spurious Emission Level (dBm)					
Lowest channel		Middle channel		Highest channel	
Spurious emissions	Level [dBm]	Spurious emissions	Level [dBm]	Spurious emissions	Level [dBm]
		1564 MHz	-46.0		
			-		
			-		
			-		
			-		
			-		
			-		
			-		
			-		

Cat NB2

Spurious Emission Level (dBm)					
Lowest channel		Lowest channel		Lowest channel	
Spurious emissions	Level [dBm]	Spurious emissions	Level [dBm]	Spurious emissions	Level [dBm]
		1564 MHz	-46.8		

Results: Cat M1

Plot 1: Middle channel, up to 30 MHz

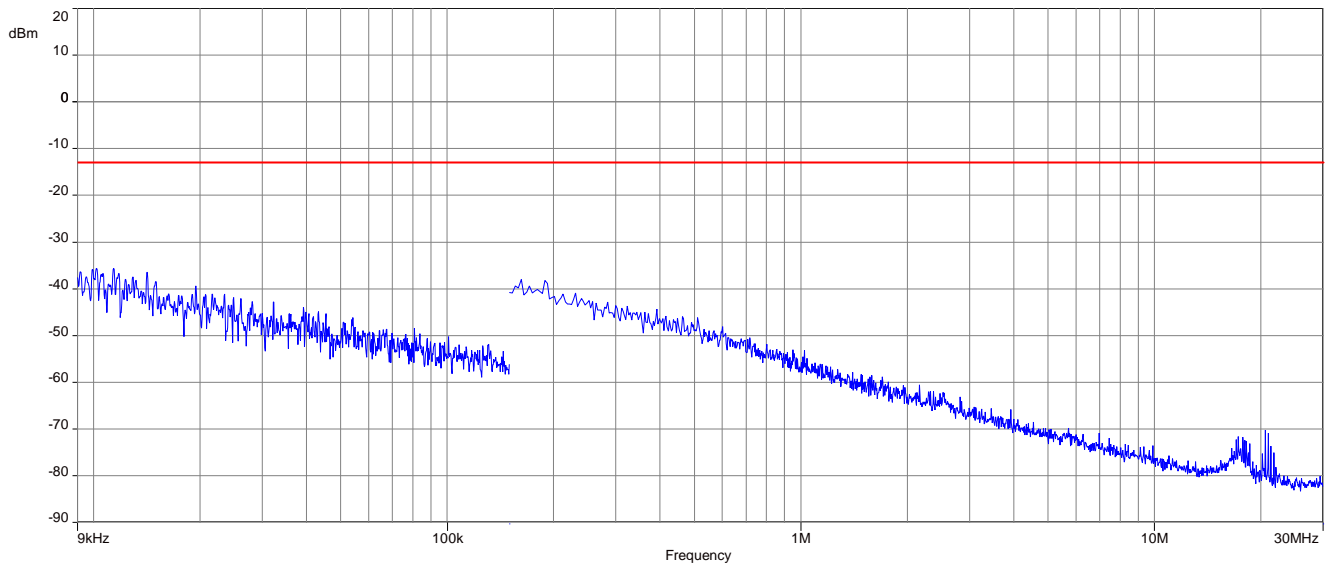

Plot 2: Middle channel, 30 MHz to 1 GHz

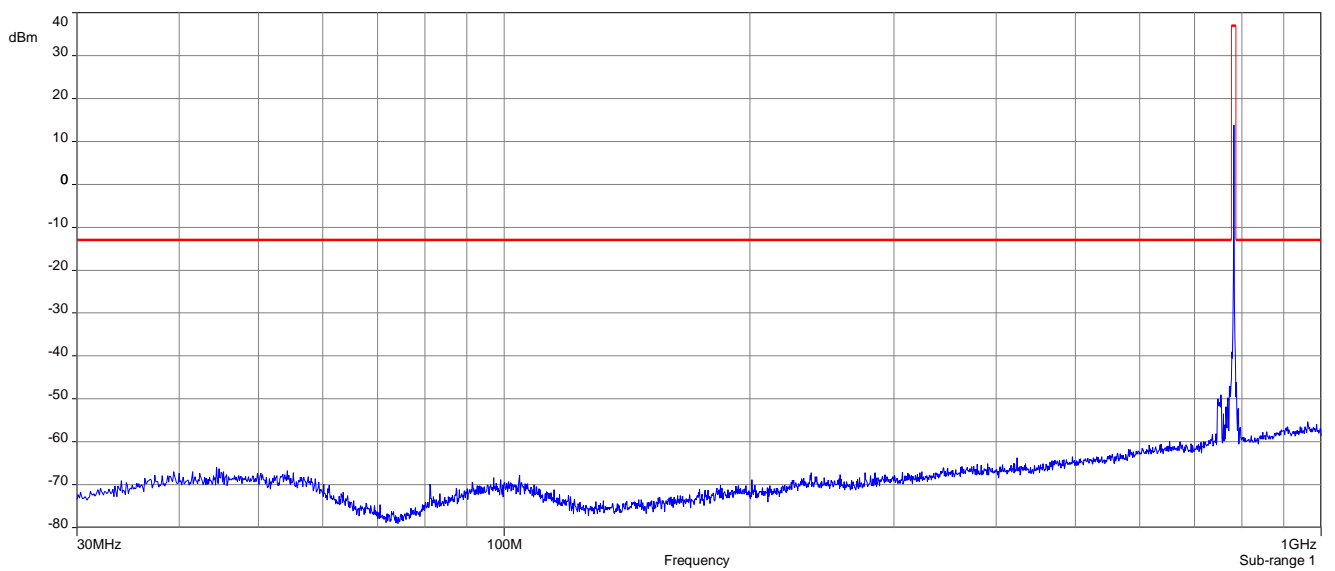

Plot 3: Middle channel, 1 GHz to 12.75 GHz

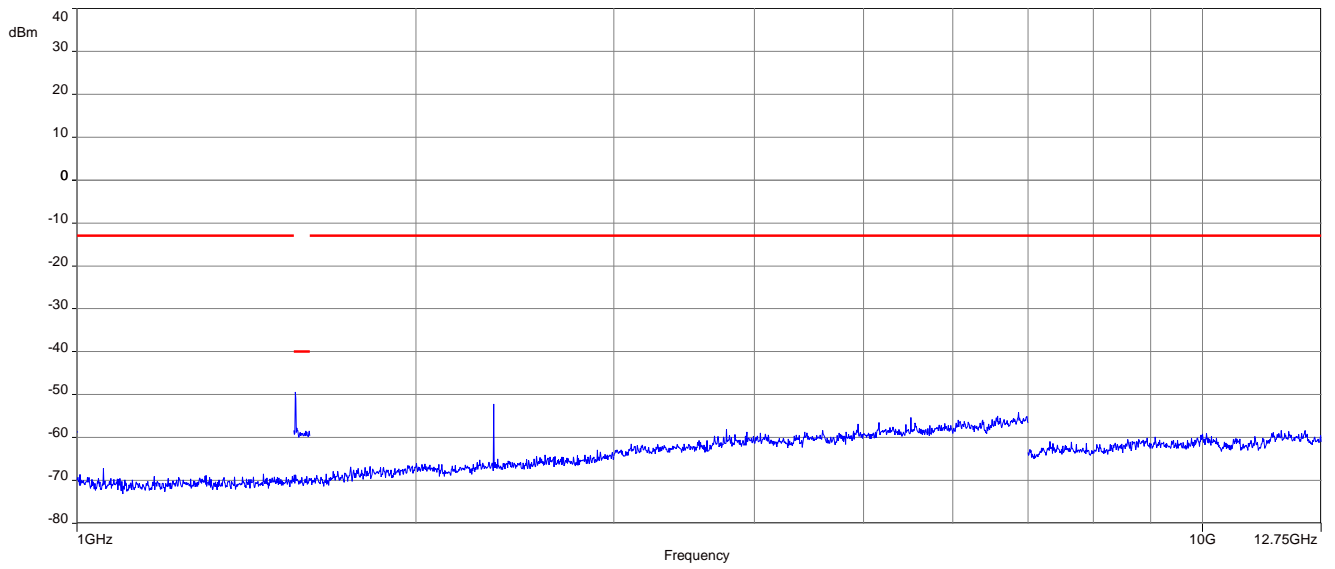

Results: Cat NB2

Plot 1: Middle channel, up to 30 MHz

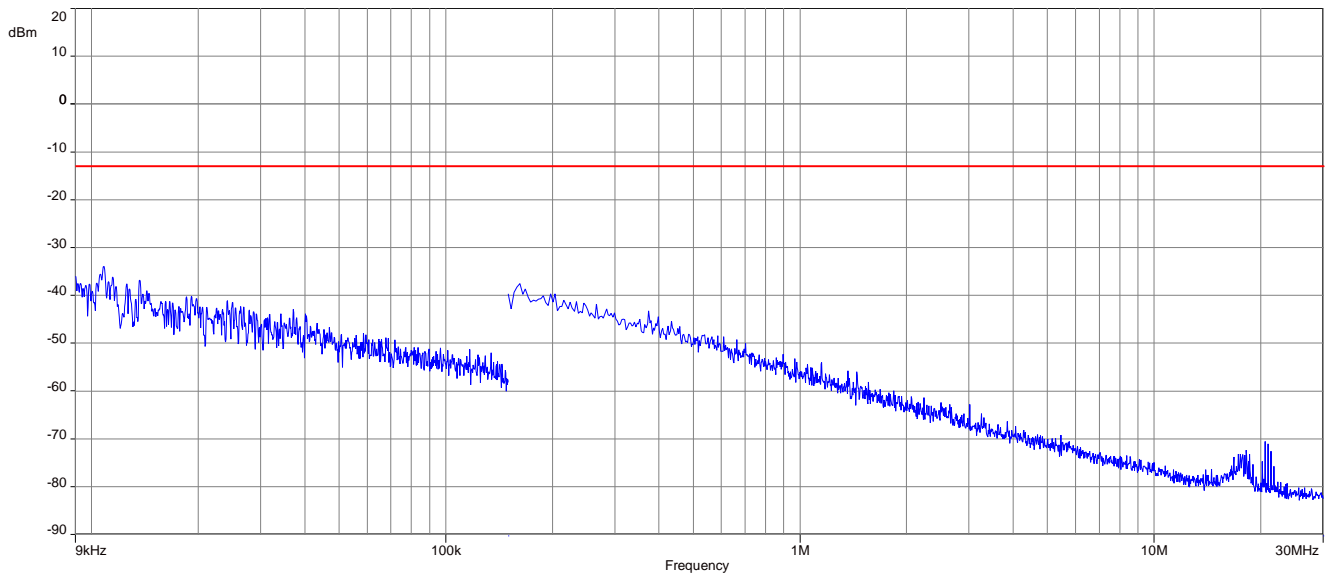

Plot 2: Middle channel, 30 MHz to 1 GHz

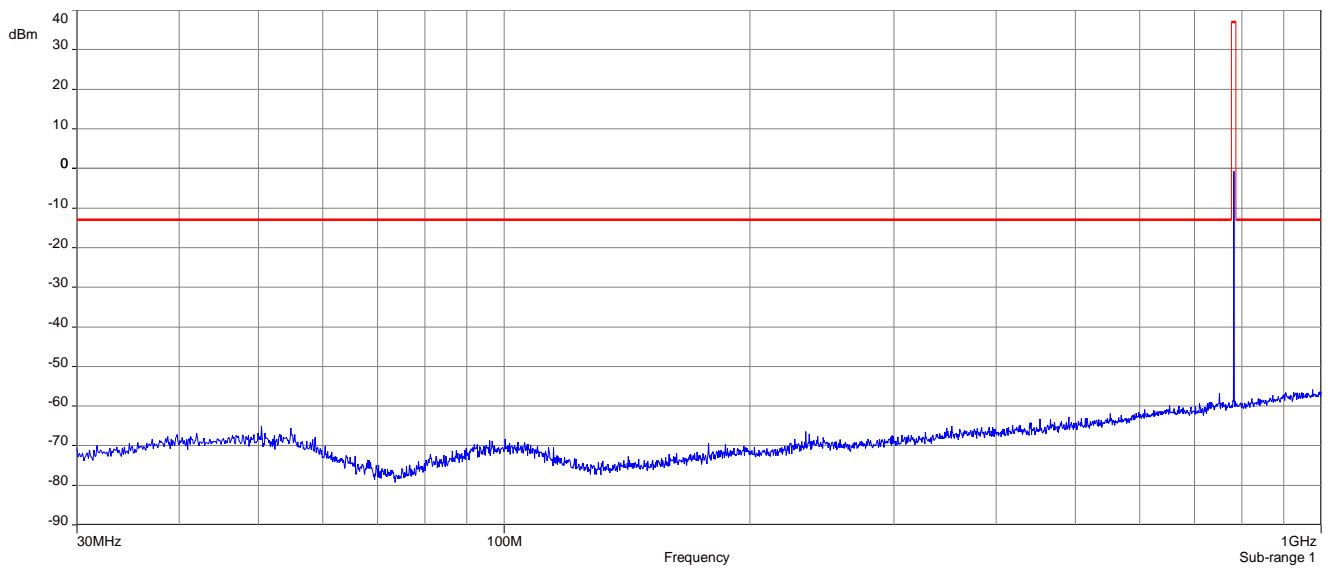

Plot 3: Middle channel, 1 GHz to 12.75 GHz

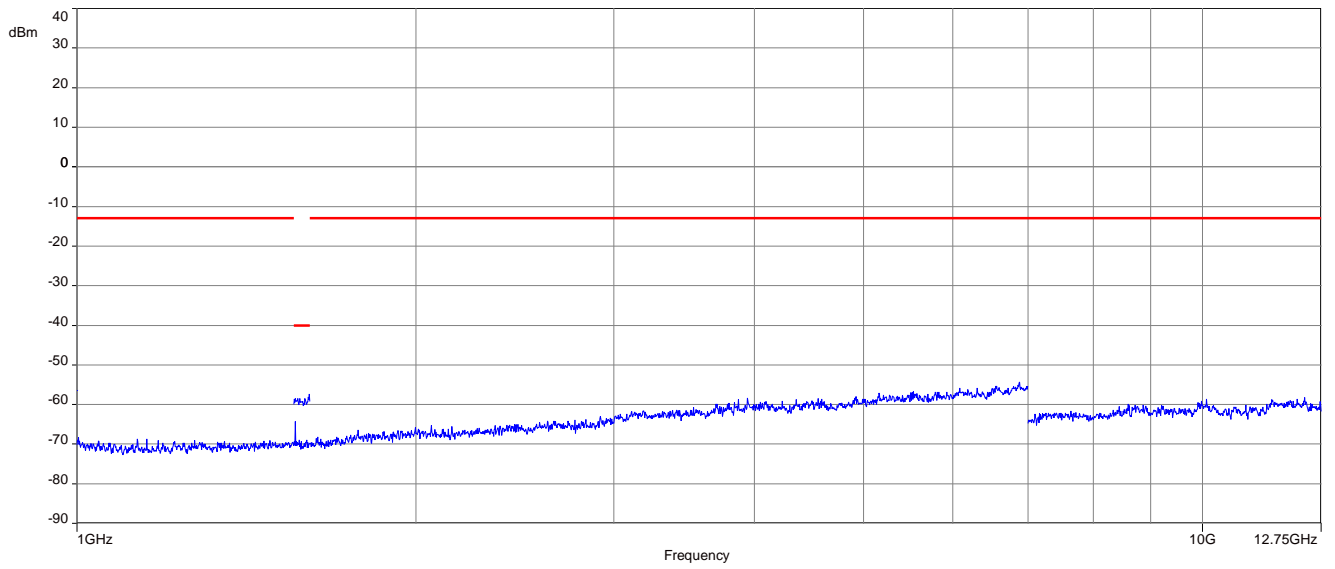

17.5 Results LTE – Band 66

The EUT was set to transmit the maximum power.

17.5.1 RF output power

Description:

This paragraph contains average power, peak output power and EIRP measurements for the mobile station. In all cases, the peak output power is within the required mask (this mask is specified in the JTC standards, TIA PN3389 Vol. 1 Chap 7, and is no FCC requirement).

Measurement:

The mobile was set up for the maximum output power with pseudo random data modulation.

Measurement parameters	
Setup	See chapter 7.2 – A
Measurement uncertainty	See chapter 9

Limits:

FCC	ISED
Max Output Power	
+30.00 dBm	
In measuring transmissions in this band using an average power technique, the peak-to-average ratio (PAR) of the transmission may not exceed 13 dB.	

Results: Cat M1

Output Power (radiated)			
Bandwidth and RB settings	Frequency (MHz)	Average Output Power (dBm) QPSK	Average Output Power (dBm) 16QAM
1.4 MHz 1#0	1710.7	16.4	15.9
1.4 MHz 1#0	1745.0	16.0	15.7
1.4 MHz 1#5	1779.3	15.8	16.0

Results: NB-IOT2

Output Power (radiated)			
Settings	Frequency (MHz)	Average Output Power (dBm) BPSK	Average Output Power (dBm) QPSK
15 kHz sub-carrier spacing	1710.7	15.8	15.8
15 kHz sub-carrier spacing	1745.0	16.3	16.3
15 kHz sub-carrier spacing	1779.3	16.3	16.3

17.5.2 Spurious emissions radiated

Description:

The following steps outline the procedure used to measure the radiated emissions from the mobile station. The site is constructed in accordance with ANSI C63.4:2014 requirements and is recognized by the FCC to be in compliance for a 3 and a 10 meter site. The spectrum was scanned from 30 MHz to the 10th harmonic of the highest frequency generated within the equipment, which is the transmitted carrier that can be as high as 1779.3 MHz. Measurement made up to 26 GHz. The resolution bandwidth is set as outlined in Part 27.53. The spectrum was scanned with the mobile station transmitting at carrier frequencies that pertain to low, mid and high channels of the LTE band 66.

Measurement:

Measurement parameters	
Detector	Peak
Sweep time	2 sec.
Video bandwidth	Below 1 GHz: 100 kHz Above 1 GHz: 1 MHz
Resolution bandwidth	Below 1 GHz: 100 kHz Above 1 GHz: 1 MHz
Span	100 MHz Steps
Trace mode	Max Hold
Setup	See chapter 7.1 - A; 7.2 – B&C; 7.3 - A
Measurement uncertainty	See chapter 9

Limits:

FCC	ISED
Spurious Emissions Radiated	
Attenuation $\geq 43 + 10\log(P) / (P, \text{Power in Watts})$	
-13 dBm	

Cat M1

Spurious Emission Level (dBm)					
Lowest channel		Middle channel		Highest channel	
Spurious emissions	Level [dBm]	Spurious emissions	Level [dBm]	Spurious emissions	Level [dBm]
All detected emissions are more than 20dB below the limit!					
	-		-		-
	-		-		-
	-		-		-
	-		-		-
	-		-		-
	-		-		-
	-		-		-

Cat NB2

Spurious Emission Level (dBm)					
Lowest channel		Middle channel		Highest channel	
Spurious emissions	Level [dBm]	Spurious emissions	Level [dBm]	Spurious emissions	Level [dBm]
All detected emissions are more than 20dB below the limit!					
	-		-		-
	-		-		-
	-		-		-
	-		-		-
	-		-		-
	-		-		-
	-		-		-

Results: Cat M1

Plot 1: Middle channel, up to 30 MHz

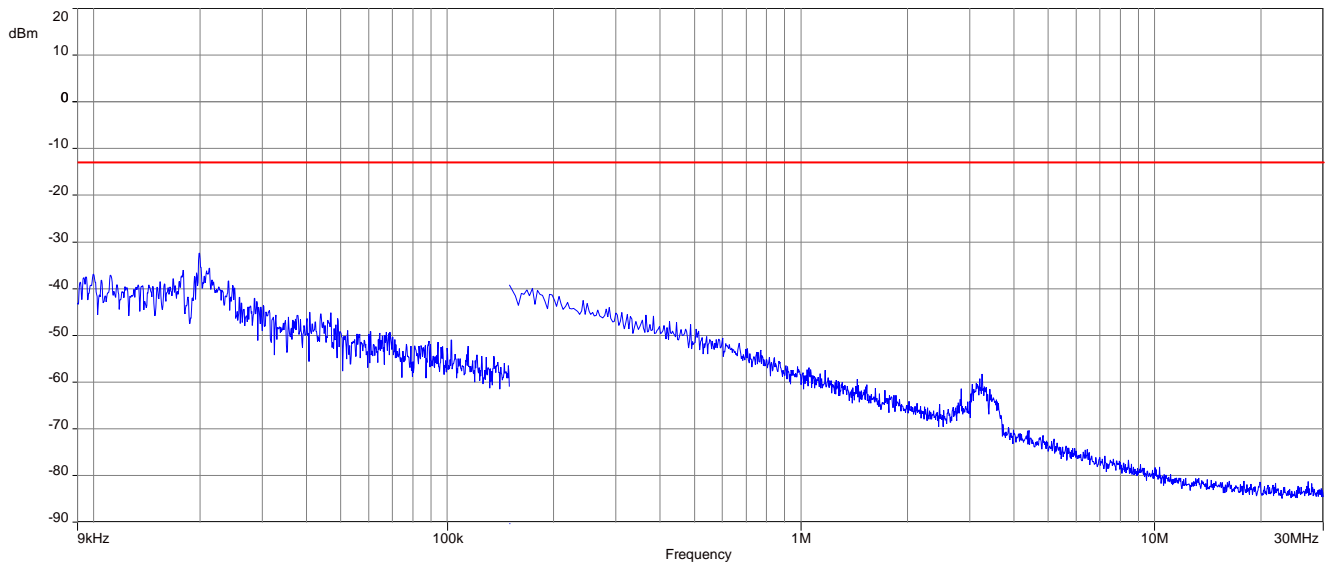

Plot 2: Middle channel, 30 MHz to 1 GHz

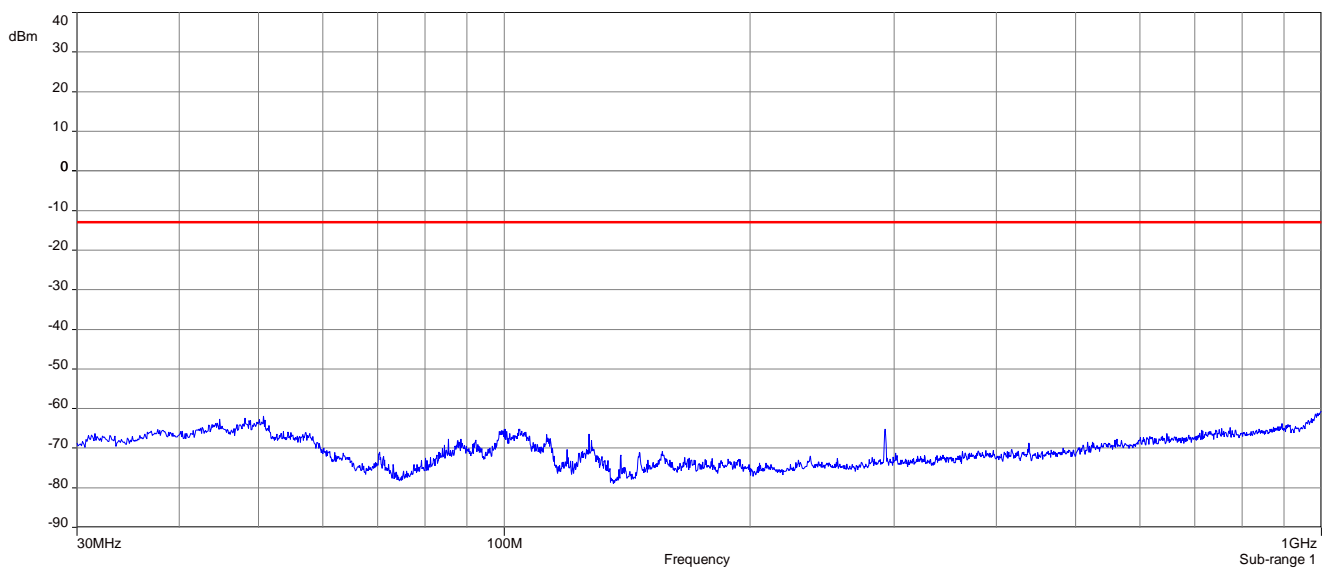

Plot 3: Middle channel, 1 GHz to 18 GHz

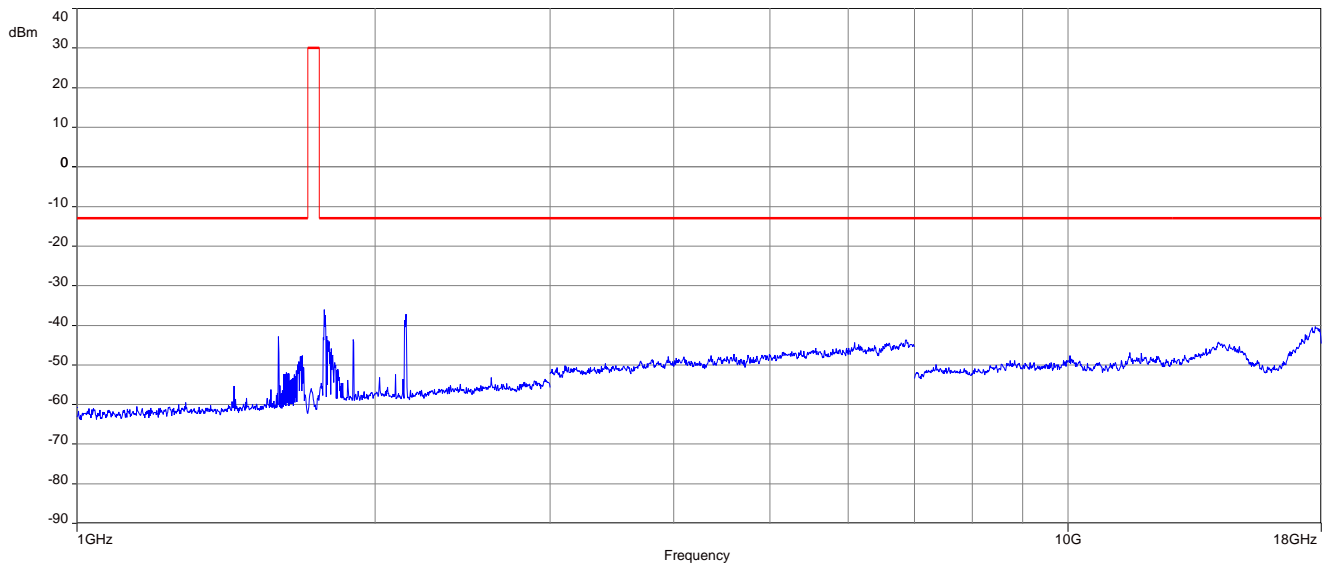

Carrier notched with 1.7 GHz rejection filter, the shown peak around 2.1 GHz is caused by the downlink signal

Results: Cat NB2

Plot 1: Middle channel, up to 30 MHz

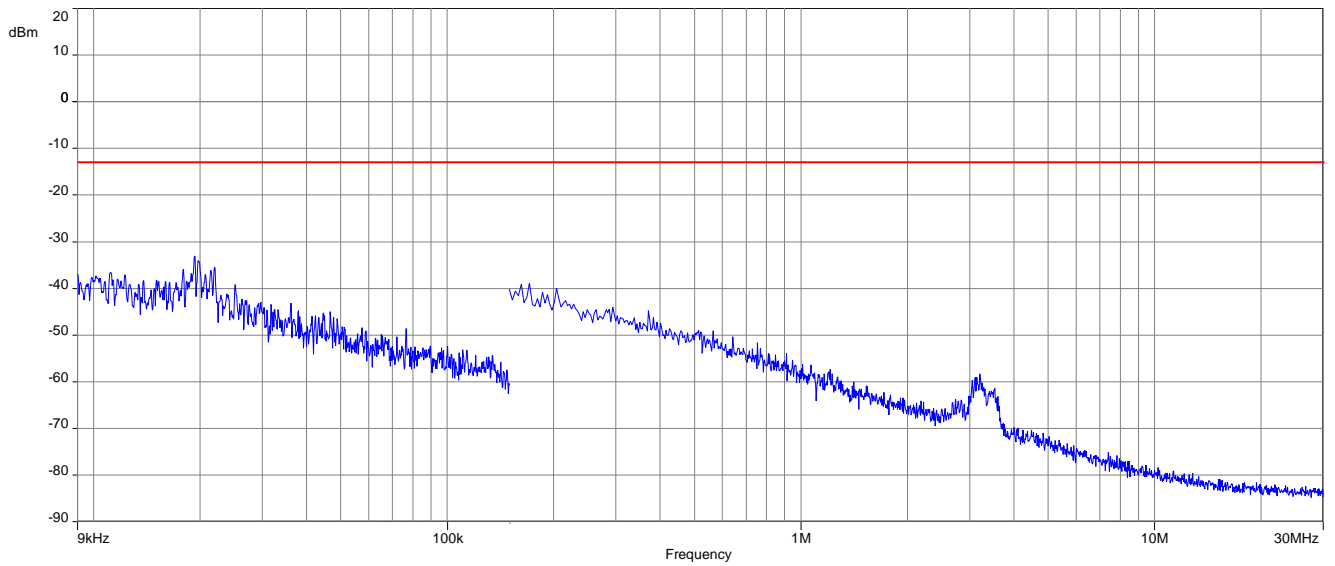

Plot 2: Middle channel, 30 MHz to 1 GHz

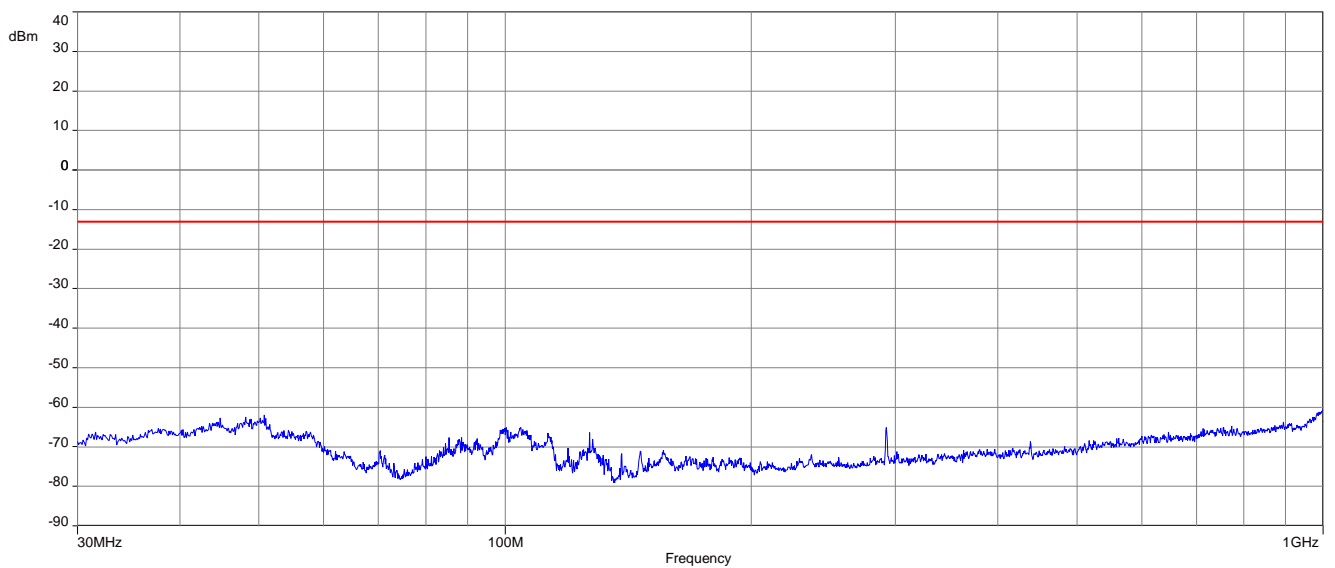

Plot 3: Middle channel, 1 GHz to 18 GHz

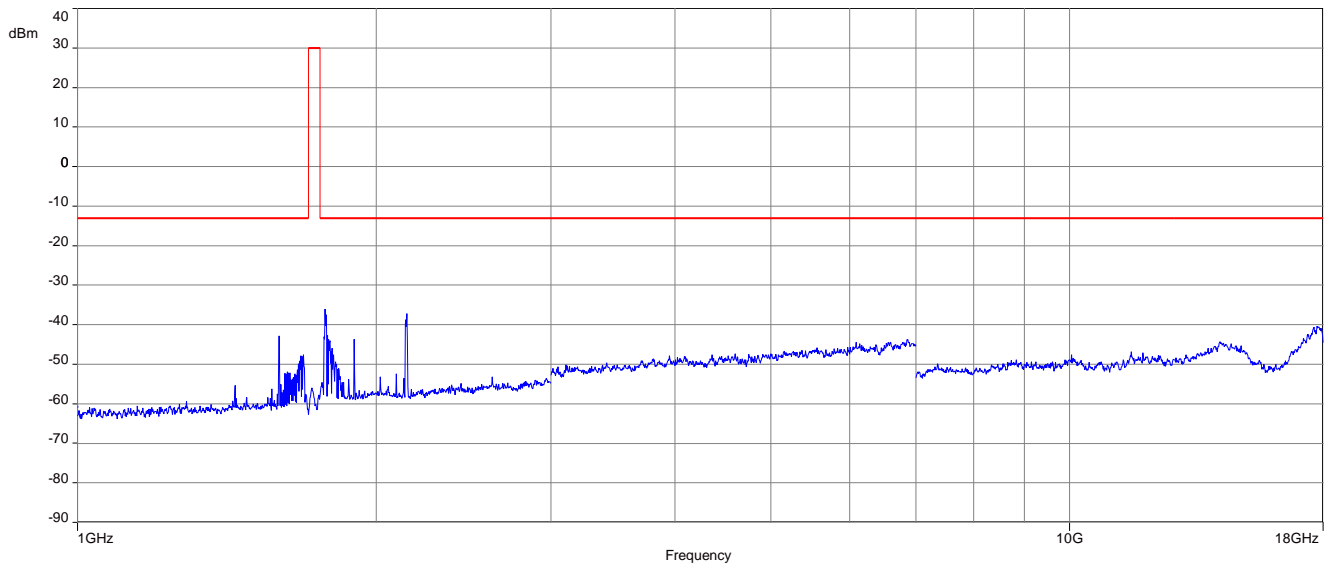

Carrier notched with 1.7 GHz rejection filter, the shown peak around 2.1 GHz is caused by the downlink signal

17.6 Results LTE – Band 71

The EUT was set to transmit the maximum power.

17.6.1 RF output power

Description:

This paragraph contains average power, peak output power and EIRP measurements for the mobile station. In all cases, the peak output power is within the required mask (this mask is specified in the JTC standards, TIA PN3389 Vol. 1 Chap 7, and is no FCC requirement).

Measurement:

The mobile was set up for the maximum output power with pseudo random data modulation.

Measurement parameters	
Setup	See chapter 7.1 – A
Measurement uncertainty	See chapter 9

Limits:

FCC	ISED
Max Output Power	
+34.77 dBm	
In measuring transmissions in this band using an average power technique, the peak-to-average ratio (PAR) of the transmission may not exceed 13 dB.	

Results: NB-IOT2

Output Power (radiated)			
Settings	Frequency (MHz)	Average Output Power (dBm) BPSK	Average Output Power (dBm) QPSK
15 kHz sub-carrier spacing	663.2	10.8	10.8
15 kHz sub-carrier spacing	680.5	10.6	10.6
15 kHz sub-carrier spacing	697.8	10.8	10.8

17.6.2 Spurious emissions radiated

Description:

The following steps outline the procedure used to measure the radiated emissions from the mobile station. The site is constructed in accordance with ANSI C63.4:2014 requirements and is recognized by the FCC to be in compliance for a 3 and a 10 meter site. The spectrum was scanned from 30 MHz to the 10th harmonic of the highest frequency generated within the equipment, which is the transmitted carrier that can be as high as 698 MHz. This was rounded up to 8 GHz. The resolution bandwidth is set as outlined in Part 27.53. The spectrum was scanned with the mobile station transmitting at carrier frequencies that pertain to low, mid and high channels of the LTE band 71.

Measurement:

Measurement parameters	
Detector	Peak
Sweep time	2 sec.
Video bandwidth	Below 1 GHz: 100 kHz Above 1 GHz: 1 MHz
Resolution bandwidth	Below 1 GHz: 100 kHz Above 1 GHz: 1 MHz
Span	100 MHz Steps
Trace mode	Max Hold
Setup	See chapter 7.1 - A; 7.2 – B&C
Measurement uncertainty	See chapter 9

Limits:

FCC	ISED
Spurious Emissions Radiated	
Attenuation $\geq 43 + 10\log(P)$ (P, Power in Watts)	
-13 dBm and 1559 MHz to 1610 MHz with -40 dBm	

Cat NB2

Spurious Emission Level (dBm)					
Lowest channel		Middle channel		Highest channel	
Spurious emissions	Level [dBm]	Spurious emissions	Level [dBm]	Spurious emissions	Level [dBm]
All detected emissions are more than 20dB below the limit!					
	-		-		-
	-		-		-
	-		-		-
	-		-		-
	-		-		-
	-		-		-
	-		-		-

Results: Cat NB2

Plot 1: Middle channel, up to 30 MHz

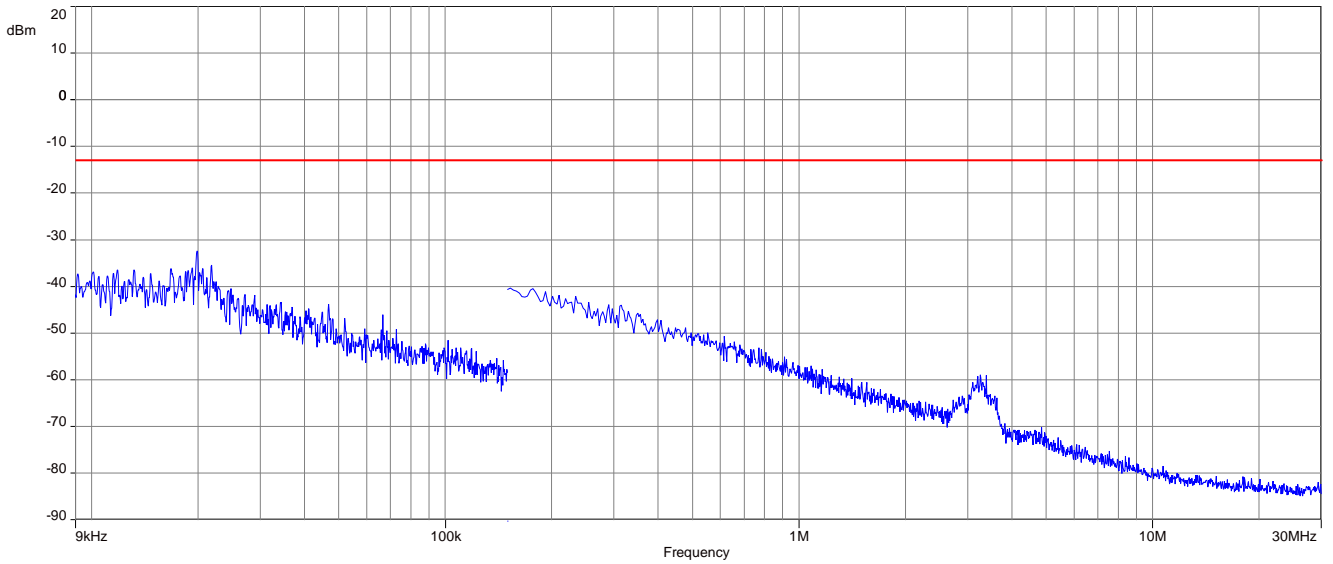

Plot 2: Middle channel, 30 MHz to 1 GHz

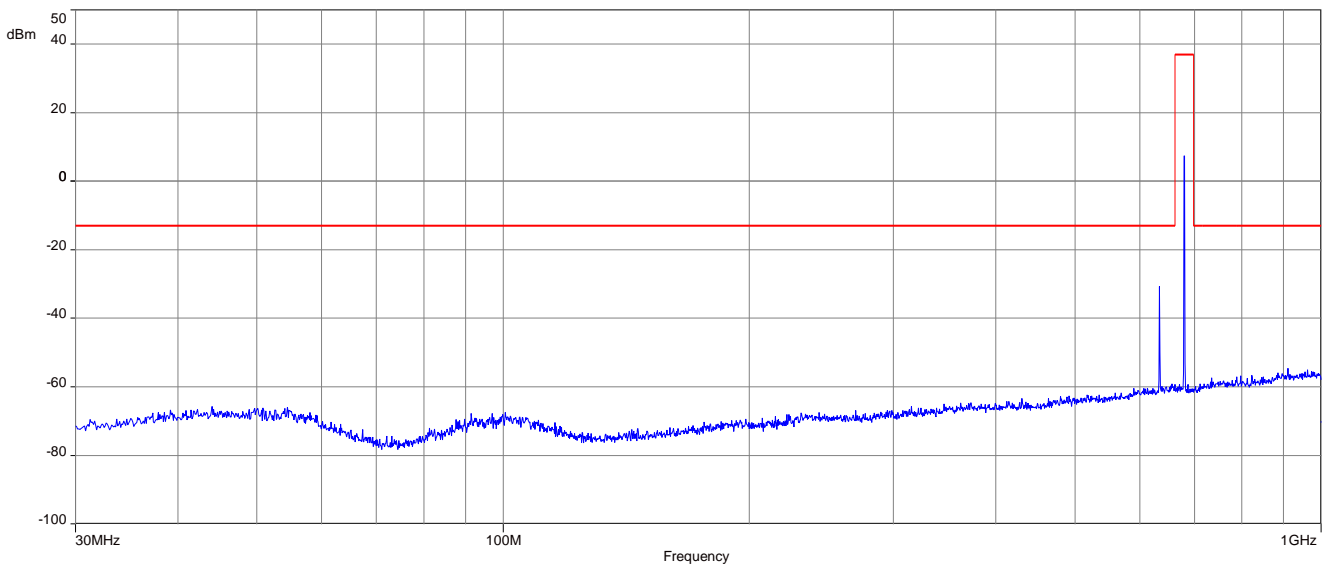

NOTE: The emission at 634 MHz is the downlink of the base station.

Plot 3: Middle channel, 1 GHz to 12.75 GHz

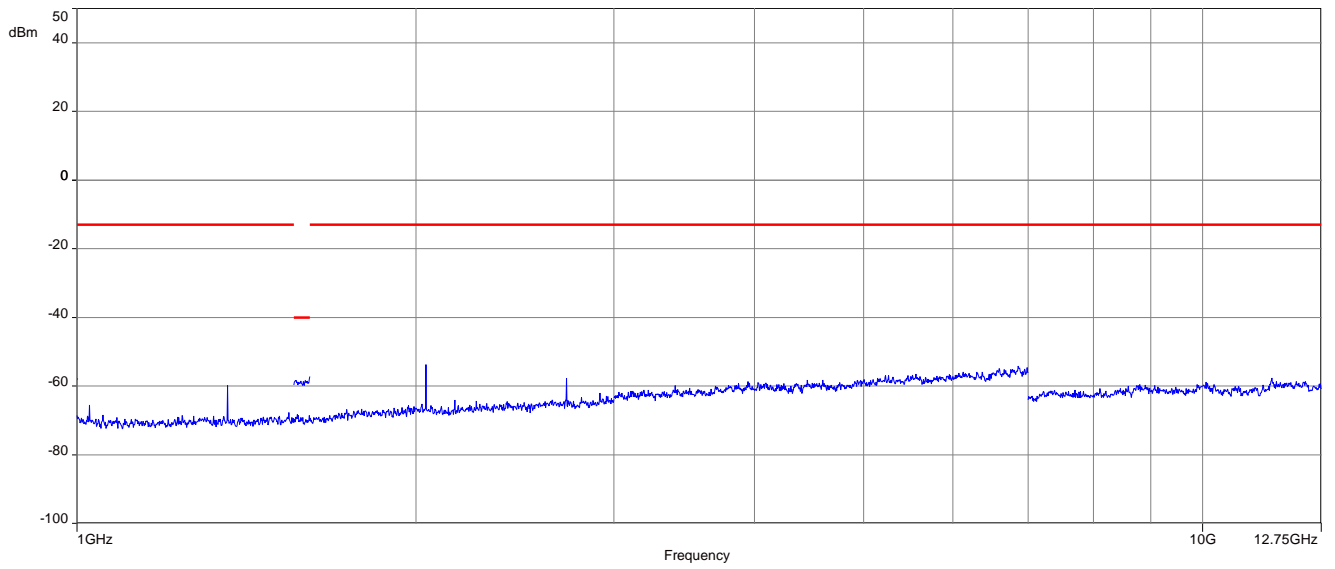

17.7 Results LTE – Band 85

The EUT was set to transmit the maximum power.

17.7.1 RF output power

Description:

This paragraph contains average power, peak output power and EIRP measurements for the mobile station. In all cases, the peak output power is within the required mask (this mask is specified in the JTC standards, TIA PN3389 Vol. 1 Chap 7, and is no FCC requirement).

Measurement:

The mobile was set up for the maximum output power with pseudo random data modulation.

Measurement parameters	
Setup	See chapter 7.1 – A
Measurement uncertainty	See chapter 9

Limits:

FCC	ISED
Nominal Peak Output Power	
+34.77 dBm	
In measuring transmissions in this band using an average power technique, the peak-to-average ratio (PAR) of the transmission may not exceed 13 dB.	

Results: Cat M1

Output Power (radiated)			
Bandwidth and RB settings	Frequency (MHz)	Average Output Power (dBm) QPSK	Average Output Power (dBm) 16QAM
1.4 MHz 1#0	700.5	15.2	15.1
1.4 MHz 1#0	707.0	15.7	15.2
1.4 MHz 1#5	713.5	15.7	15.1

Results: NB-IOT2

Output Power (radiated)			
Settings	Frequency (MHz)	Average Output Power (dBm) BPSK	Average Output Power (dBm) QPSK
15 kHz sub-carrier spacing	700.5	14.7	14.7
15 kHz sub-carrier spacing	707.0	15.4	15.3
15 kHz sub-carrier spacing	713.5	15.3	15.3

17.7.2 Spurious emissions radiated

Description:

The following steps outline the procedure used to measure the radiated emissions from the mobile station. The site is constructed in accordance with ANSI C63.4:2014 requirements and is recognized by the FCC to be in compliance for a 3 and a 10 meter site. The spectrum was scanned from 30 MHz to the 10th harmonic of the highest frequency generated within the equipment, which is the transmitted carrier that can be as high as 713.5 MHz. Measured up to 12.75 GHz. The resolution bandwidth is set as outlined in Part 27.53. The spectrum was scanned with the mobile station transmitting at carrier frequencies that pertain to low, mid and high channels of the LTE band 85.

Measurement:

Measurement parameters	
Detector	Peak
Sweep time	2 sec.
Video bandwidth	Below 1 GHz: 100 kHz Above 1 GHz: 1 MHz
Resolution bandwidth	Below 1 GHz: 100 kHz Above 1 GHz: 1 MHz
Span	100 MHz Steps
Trace mode	Max Hold
Setup	See chapter 7.1 - A; 7.2 – B&C
Measurement uncertainty	See chapter 9

Limits:

FCC	ISED
Spurious Emissions Radiated	
Attenuation $\geq 43 + 10\log(P)$ (P, Power in Watts)	
-13 dBm	

Cat M1

Spurious Emission Level (dBm)					
Lowest channel		Middle channel		Highest channel	
Spurious emissions	Level [dBm]	Spurious emissions	Level [dBm]	Spurious emissions	Level [dBm]
			-		
			-		
			-		
			-		
			-		
			-		
			-		
			-		
			-		

Cat NB2

Spurious Emission Level (dBm)					
Lowest channel		Lowest channel		Lowest channel	
Spurious emissions	Level [dBm]	Spurious emissions	Level [dBm]	Spurious emissions	Level [dBm]

Results: Cat M1

Plot 1: Middle channel, up to 30 MHz

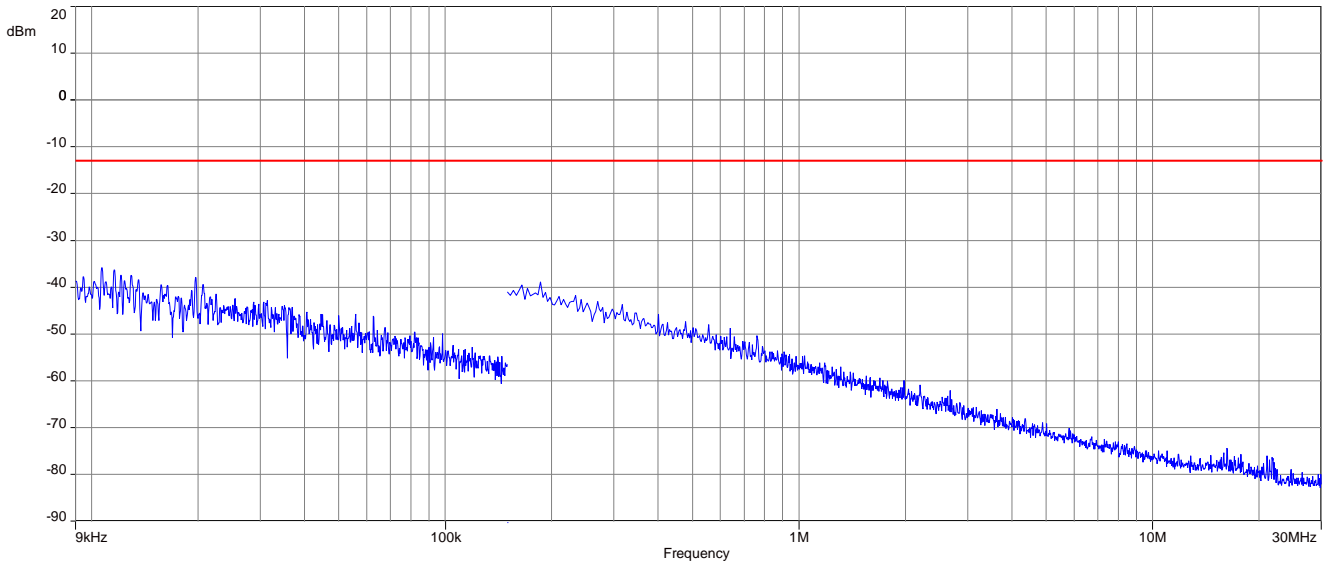

Plot 2: Middle channel, 30 MHz to 1 GHz

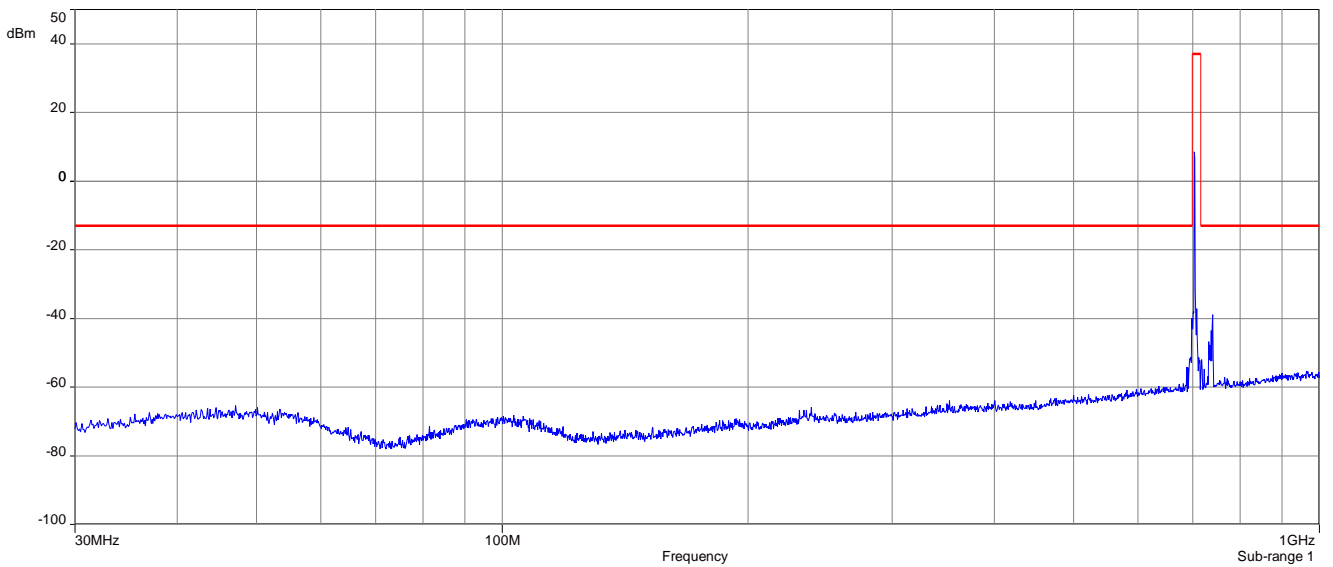

Plot 3: Middle channel, 1 GHz to 12.75 GHz

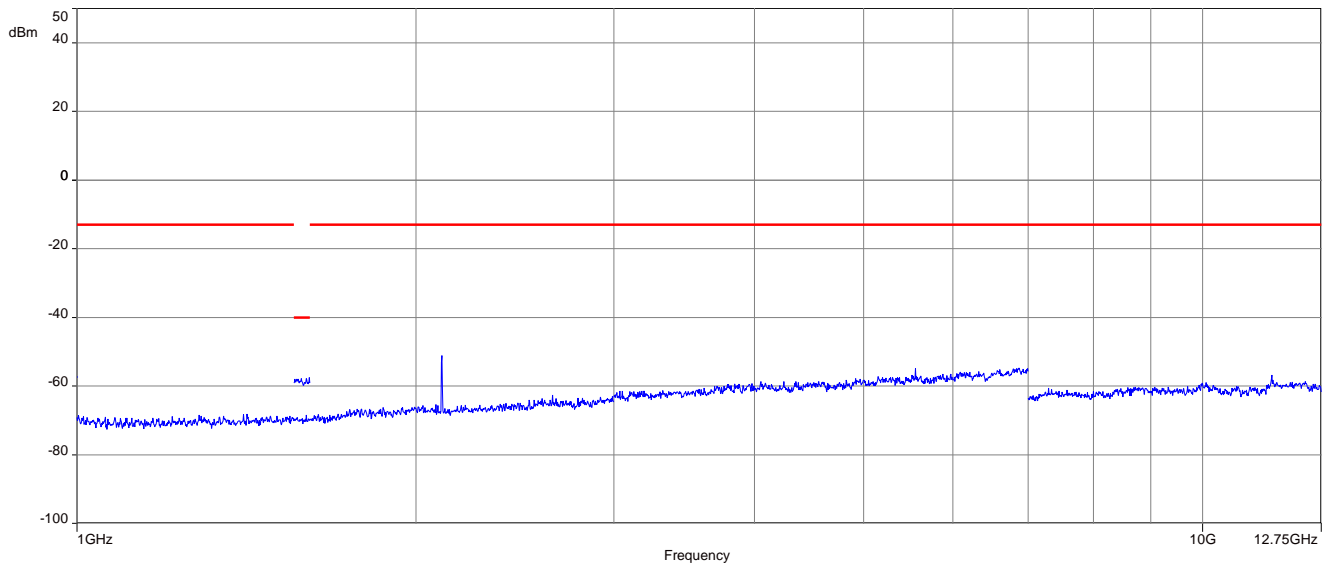

Results: Cat NB2

Plot 1: Middle channel, up to 30 MHz

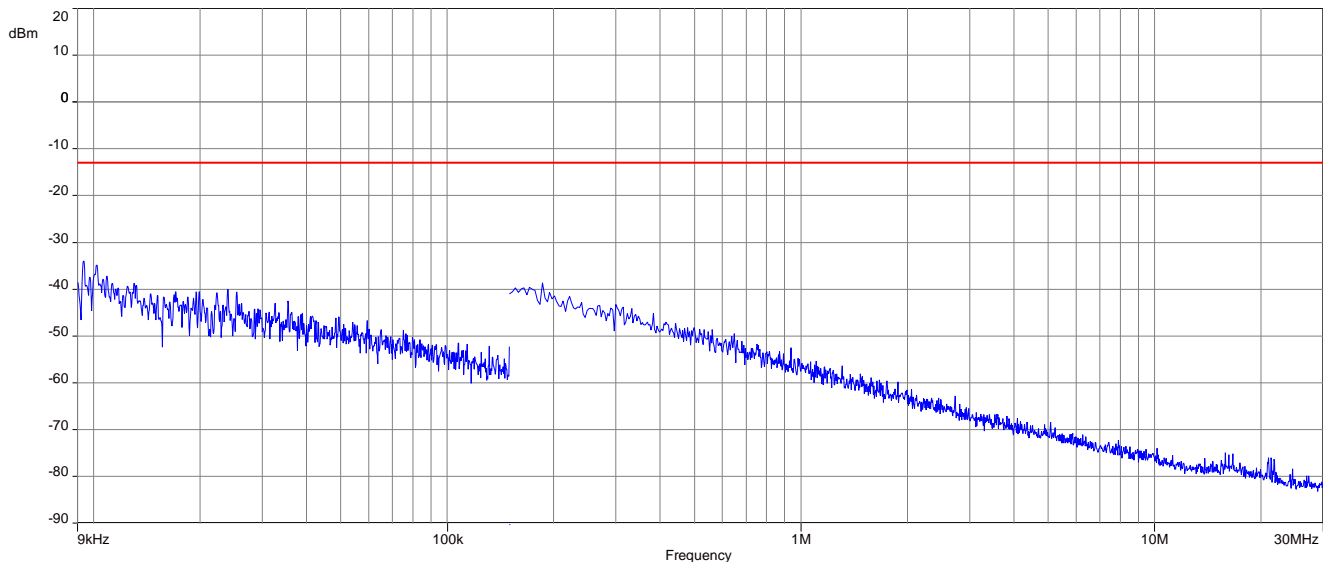

Plot 2: Middle channel, 30 MHz to 1 GHz

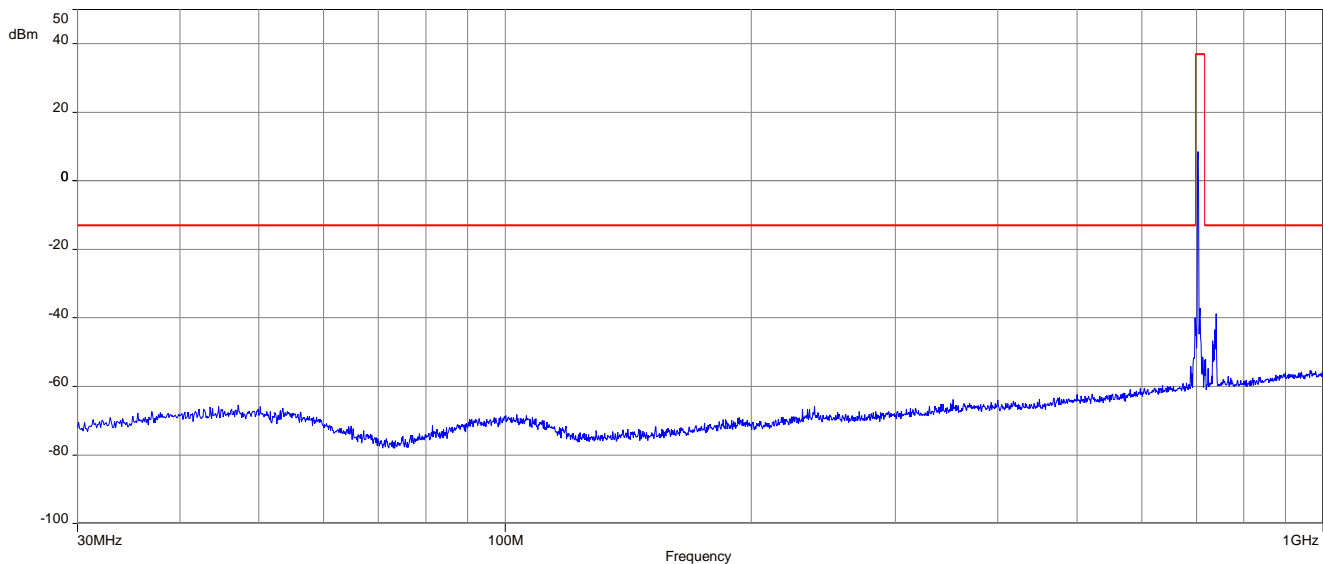

Plot 3: Middle channel, 1 GHz to 9 GHz

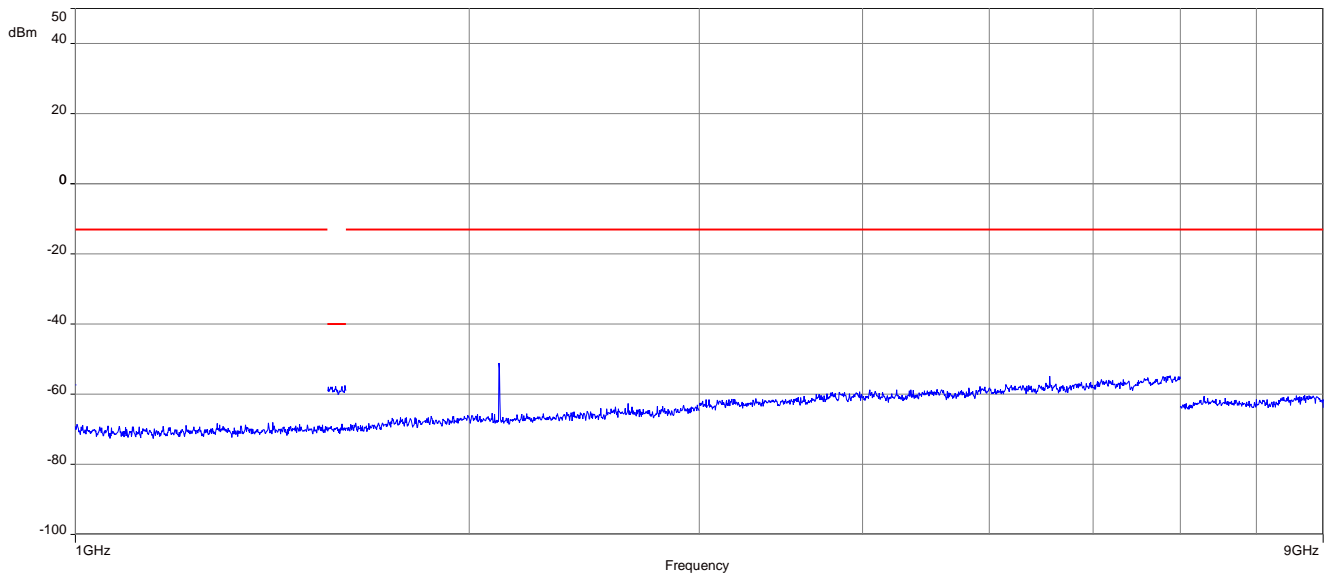

18 Glossary

EUT	Equipment under test
DUT	Device under test
UUT	Unit under test
GUE	GNSS User Equipment
ETSI	European Telecommunications Standards Institute
EN	European Standard
FCC	Federal Communications Commission
FCC ID	Company Identifier at FCC
IC	Industry Canada
PMN	Product marketing name
HMN	Host marketing name
HVIN	Hardware version identification number
FVIN	Firmware version identification number
EMC	Electromagnetic Compatibility
HW	Hardware
SW	Software
Inv. No.	Inventory number
S/N or SN	Serial number
C	Compliant
NC	Not compliant
NA	Not applicable
NP	Not performed
PP	Positive peak
QP	Quasi peak
AVG	Average
OC	Operating channel
OCW	Operating channel bandwidth
OBW	Occupied bandwidth
OOB	Out of band
DFS	Dynamic frequency selection
CAC	Channel availability check
OP	Occupancy period
NOP	Non occupancy period
DC	Duty cycle
PER	Packet error rate
CW	Clean wave
MC	Modulated carrier
WLAN	Wireless local area network
RLAN	Radio local area network
DSSS	Dynamic sequence spread spectrum
OFDM	Orthogonal frequency division multiplexing
FHSS	Frequency hopping spread spectrum
GNSS	Global Navigation Satellite System
C/N₀	Carrier to noise-density ratio, expressed in dB-Hz

19 Document history

Version	Applied changes	Date of release
-/-	Initial release	2021-07-30
A	Editorial changes (Manufacturer/Applicant, temperature range in combination with the internal battery) Referenced FCC Part and RSS added	2021-08-06

20 Accreditation Certificate – D-PL-12076-01-04

first page	last page
 <p>Deutsche Akkreditierungsstelle GmbH</p> <p>Entrusted according to Section 8 subsection 1 AkkStelleG in connection with Section 1 subsection 1 AkkStelleGBV Signatory to the Multilateral Agreements of EA, ILAC and IAF for Mutual Recognition</p> <p>Accreditation </p> <p>The Deutsche Akkreditierungsstelle GmbH attests that the testing laboratory CTC advanced GmbH Untertürkheimer Straße 6-10, 66117 Saarbrücken is competent under the terms of DIN EN ISO/IEC 17025:2018 to carry out tests in the following fields: Telecommunication (TC) and Electromagnetic Compatibility (EMC) for Canadian Standards</p> <p>The accreditation certificate shall only apply in connection with the notice of accreditation of 09.06.2020 with the accreditation number D-PL-12076-01. It comprises the cover sheet, the reverse side of the cover sheet and the following annex with a total of 07 pages. Registration number of the certificate: D-PL-12076-01-04</p> <p>Frankfurt am Main, 09.06.2020 by order:  Frank Egnor Head of Division</p> <p><small>The certificate together with its annex reflects the status at the time of the date of issue. The current status of the scope of accreditation can be found in the database of accredited bodies of Deutsche Akkreditierungsstelle GmbH. https://www.dakks.de/en/content/accredited-bodies-dakks See notes overleaf.</small></p>	<p>Deutsche Akkreditierungsstelle GmbH</p> <p>Office Berlin Spittelmarkt 10 10117 Berlin</p> <p>Office Frankfurt am Main Europa-Allee 52 60327 Frankfurt am Main</p> <p>Office Braunschweig Bundesallee 100 38116 Braunschweig</p> <p>The publication of extracts of the accreditation certificate is subject to the prior written approval by Deutsche Akkreditierungsstelle GmbH (DAkKS). Exempted is the unchanged form of separate disseminations of the cover sheet by the conformity assessment body mentioned overleaf.</p> <p>No impression shall be made that the accreditation also extends to fields beyond the scope of accreditation attested by DAkKS.</p> <p>The accreditation was granted pursuant to the Act on the Accreditation Body (AkkStelleG) of 31 July 2009 (Federal Law Gazette I p. 2625) and the Regulation (EC) No 765/2008 of the European Parliament and of the Council of 9 July 2008 setting out the requirements for accreditation and market surveillance relating to the marketing of products (Official Journal of the European Union L 218 of 9 July 2008, p. 30). DAkKS is a signatory to the Multilateral Agreements for Mutual Recognition of the European co-operation for Accreditation (EA), International Accreditation Forum (IAF) and International Laboratory Accreditation Cooperation (ILAC). The signatories to these agreements recognise each other's accreditations.</p> <p>The up-to-date state of membership can be retrieved from the following websites: EA: www.european-accreditation.org ILAC: www.ilac.org IAF: www.iaf.nu</p>

Note: The current certificate annex is published on the website (link see below) of the Accreditation Body DAkKS or may be received by CTC advanced GmbH on request

<https://www.dakks.de/as/ast/d/D-PL-12076-01-04e.pdf>

21 Accreditation Certificate – D-PL-12076-01-05

first page	last page			
 <p>Deutsche Akkreditierungsstelle GmbH</p> <p>Entrusted according to Section 8 subsection 1 AkkStelleG in connection with Section 1 subsection 1 AkkStelleGBV Signatory to the Multilateral Agreements of EA, ILAC and IAF for Mutual Recognition</p> <p>Accreditation </p> <p>The Deutsche Akkreditierungsstelle GmbH attests that the testing laboratory CTC advanced GmbH Untertürkheimer Straße 6-10, 66117 Saarbrücken is competent under the terms of DIN EN ISO/IEC 17025:2018 to carry out tests in the following fields:</p> <p>Telecommunication (FCC Requirements)</p> <p>The accreditation certificate shall only apply in connection with the notice of accreditation of 09.06.2020 with the accreditation number D-PL-12076-01. It comprises the cover sheet, the reverse side of the cover sheet and the following annex with a total of 05 pages.</p> <p>Registration number of the certificate: D-PL-12076-01-05</p> <p>Frankfurt am Main, 09.06.2020</p> <p>by  Dipl.-Ing. (FH) Alf Egner Head of Division</p> <p><small>The certificate together with its annex reflects the status at the time of the date of issue. The current status of the scope of accreditation can be found in the database of accredited bodies of Deutsche Akkreditierungsstelle GmbH. https://www.dakks.de/en/content/accredited-bodies-dakks See also: www.dakks.de</small></p>	<p>Deutsche Akkreditierungsstelle GmbH</p> <table border="0"> <tr> <td>Office Berlin Spittelmarkt 10 10117 Berlin</td> <td>Office Frankfurt am Main Europa-Allee 52 60327 Frankfurt am Main</td> <td>Office Braunschweig Bundesallee 100 38116 Braunschweig</td> </tr> </table> <p>The publication of extracts of the accreditation certificate is subject to the prior written approval by Deutsche Akkreditierungsstelle GmbH (DAkKS). Exempted is the unchanged form of separate disseminations of the cover sheet by the conformity assessment body mentioned overleaf.</p> <p>No impression shall be made that the accreditation also extends to fields beyond the scope of accreditation attested by DAkKS.</p> <p>The accreditation was granted pursuant to the Act on the Accreditation Body (AkkStelleG) of 31 July 2009 (Federal Law Gazette I p. 2625) and the Regulation (EC) No 765/2008 of the European Parliament and of the Council of 9 July 2008 setting out the requirements for accreditation and market surveillance relating to the marketing of products (Official Journal of the European Union L 218 of 9 July 2008, p. 30). DAkKS is a signatory to the Multilateral Agreements for Mutual Recognition of the European co-operation for Accreditation (EA), International Accreditation Forum (IAF) and International Laboratory Accreditation Cooperation (ILAC). The signatories to these agreements recognise each other's accreditations.</p> <p>The up-to-date state of membership can be retrieved from the following websites: EA: www.european-accreditation.org ILAC: www.ilac.org IAF: www.iaf.nu</p>	Office Berlin Spittelmarkt 10 10117 Berlin	Office Frankfurt am Main Europa-Allee 52 60327 Frankfurt am Main	Office Braunschweig Bundesallee 100 38116 Braunschweig
Office Berlin Spittelmarkt 10 10117 Berlin	Office Frankfurt am Main Europa-Allee 52 60327 Frankfurt am Main	Office Braunschweig Bundesallee 100 38116 Braunschweig		

Note: The current certificate annex is published on the website (link see below) of the Accreditation Body DAkKS or may be received by CTC advanced GmbH on request

<https://www.dakks.de/as/ast/d/D-PL-12076-01-05e.pdf>

END OF TEST REPORT