

S

T

S

L

A

B



# RADIO TEST REPORT

Report No.: STS1912245W03

Issued for

Telit Communications S.p.A.

Viale Stazione di Prosecco 5/b, 34010, Trieste, Italy

<b>Product Name:</b>	Data Terminal Module
<b>Brand Name:</b>	Telit
<b>Model Name:</b>	ME910G1-WW
<b>Series Model:</b>	N/A
<b>FCC ID:</b>	RI7ME910G1WW
<b>IC:</b>	5131A-ME910G1WW
<b>Test Standard:</b>	FCC Part 22 FCC Part 24 RSS-132 issue 3 RSS-133 issue 6

Any reproduction of this document must be done in full. No single part of this document may be reproduced without permission from STS, All Test Data Presented in this report is only applicable to presented Test sample.

Shenzhen STS Test Services Co., Ltd.  
A 1/F, Building B, Zhuoke Science Park, No.190 Chongqing Road, HepingShequ,  
Fuyong Sub-District, Bao'an District, Shenzhen, Guang Dong, China  
TEL: +86-755 3688 6288 FAX: +86-755 3688 6277 E-mail:sts@stsapp.com





### TEST RESULT CERTIFICATION

Applicant's Name .....: Telit Communications S.p.A.  
 Address.....: Viale Stazione di Prosecco 5/b, 34010, Trieste, Italy  
 Manufacture's Name .....: Telit Communications S.p.A.  
 Address.....: Viale Stazione di Prosecco 5/b, 34010, Trieste, Italy

#### Product Description

Product Name .....: Data Terminal Module  
 Brand Name .....: Telit  
 Model Name.....: ME910G1-WW  
 Series Model .....: N/A  
 Test Standards .....: FCC Part 22  
                                   FCC Part 24  
                                   RSS-132 issue 3  
                                   RSS-133 issue 6  
 Test Procedure.....: KDB 971168 D01 v03r01, ANSI C63.26( 2015)

This device described above has been tested by STS, the test results show that the equipment under test (EUT) is in compliance with the FCC/IC requirements. And it is applicable only to the tested sample identified in the report.  
 This report shall not be reproduced except in full, without the written approval of STS, this document may be altered or revised by STS, personal only, and shall be noted in the revision of the document..

**Date of Test**..... :  
 Date of receipt of test item .....: 16 Dec. 2019  
 Date (s) of performance of tests : 16 Dec. 2019 ~ 4 Mar. 2020  
 Date of Issue .....: 5 Mar. 2020  
 Test Result .....: Pass

Testing Engineer :   
 \_\_\_\_\_  
 (Chris Chen)

Technical Manager :   
 \_\_\_\_\_  
 (Sean she)

Authorized Signatory :   
 \_\_\_\_\_  
 (Vita Li)





Table of Contents	Page
<b>1 INTRODUCTION</b>	<b>6</b>
1.1 TEST FACTORY	6
1.2 MEASUREMENT UNCERTAINTY	6
<b>2 PRODUCT INFORMATION</b>	<b>7</b>
<b>3 TEST CONFIGURATION OF EQUIPMENT UNDER TEST</b>	<b>8</b>
<b>4 MEASUREMENT INSTRUMENTS</b>	<b>9</b>
<b>5 TEST ITEMS</b>	<b>10</b>
5.1 CONDUCTED OUTPUT POWER	10
5.2 PEAK TO AVERAGE RATIO	11
5.3 OCCUPIED BANDWIDTH	12
5.4 FREQUENCY STABILITY	13
5.5 SPURIOUS EMISSIONS AT ANTENNA TERMINALS	14
5.6 BAND EDGE	15
5.7 FIELD STRENGTH OF SPURIOUS RADIATION MEASUREMENT	16
5.8 MODULATION CHARACTERISTICS	18
<b>APPENDIX A.TESTRESULT</b>	<b>19</b>
A1.CONDUCTED OUTPUT POWER	19
A2. PEAK-TO-AVERAGE RADIO	21
A3. OCCUPIED BANDWIDTH (99% OCCUPIED BANDWIDTH/26DB BANDWIDTH)	22
A4.FREQUENCY STABILITY	25
A5. SPURIOUS EMISSIONS AT ANTENNA TERMINALS	30
A6. BAND EDGE	35
A7. FIELD STRENGTH OF SPURIOUS RADIATION MEASUREMENT	37
<b>APPENDIX-PHOTOS OF TEST SETUP</b>	<b>61</b>

**Revision History**

Rev.	Issue Date	Report NO.	Effect Page	Contents
00	5 Mar. 2020	STS1912245W03	ALL	Initial Issue





## SUMMARY OF TEST RESULTS

Test procedures according to the technical standards:

The radiated emission testing was performed according to the procedures of KDB 971168 D01 v03r01 and ANSI C63.26( 2015)

FCC Rules	Test Description	Test Result
2.1049, 22.913, 24.232 RSS-132 Issue 3(5.4) RSS-133 Issue 6 (6.4)	Conducted OutputPower Effective Radiated Power/Equivalent Isotropic Radiated Power	PASS
2.0146, 24.232 RSS-132 Issue 3 (5.4) RSS-133 Issue 6 (6.4)	Peak-to-AverageRatio	PASS
2.1049 RSS-Gen (6.7)	Occupied Bandwidth Emissions Bandwidth	PASS
2.1055, 22.355, 24.235 RSS-132 Issue 3 (5.3) RSS-133 Issue 6 (6.3)	Frequency Stability	PASS
2.1051, 22.917, 24.238 RSS-132 Issue 3 (5.5) RSS-133 Issue 6 (6.5)	Spurious Emission at Antenna Terminals	PASS
2.1053, 22.917, 24.238 RSS-132 Issue 3 (5.5) RSS-133 Issue 6 (6.5)	Field Strength of Spurious Radiation	PASS
2.1051, 22.917, 24.238 RSS-132 Issue 3 (5.5) RSS-133 Issue 6 (6.5)	Band Edge	PASS
2.1047 RSS-132 Issue 3 (5.2) RSS-133 Issue 6 (6.2)	Modulation Characteristics	PASS



## 1 INTRODUCTION

### 1.1 TEST FACTORY

SHENZHEN STS TEST SERVICES CO., LTD

Add. : A 1/F, Building B, Zhuoke Science Park, No.190 Chongqing Road, HepingShequ, Fuyong Sub-District, Bao'an District, Shenzhen, Guang Dong, China

FCC test Firm Registration Number: 625569

IC test Firm Registration Number: 12108A

A2LA Certificate No.: 4338.01

### 1.2 MEASUREMENT UNCERTAINTY

The measurement uncertainties shown below were calculated in accordance with the requirements of ANSI C63.4-2014. All measurement uncertainty values are shown with a coverage factor of  $k = 2$  to indicate a 95% level of confidence. The measurement data shown herein meets or exceeds the CISPR measurement uncertainty values specified in CISPR 16-4-2 and, thus, can be compared directly to specified limits to determine compliance.

No.	Item	Uncertainty
1	RF output power, conducted	$\pm 0.68\text{dB}$
2	Unwanted Emissions, conducted	$\pm 2.988\text{dB}$
3	All emissions, radiated 30-1GHz	$\pm 6.7\text{dB}$
4	All emissions, radiated 1G-6GHz	$\pm 5.5\text{dB}$
5	All emissions, radiated >6G	$\pm 5.8\text{dB}$
6	Conducted Emission (9KHz-150KHz)	$\pm 4.43\text{dB}$
7	Conducted Emission (150KHz-30MHz)	$\pm 5\text{dB}$



## 2 PRODUCT INFORMATION

Product Name	Data Terminal Module
Trade Name	Telit
Model Name	ME910G1-WW
Series Model	N/A
Model Difference	N/A
Tx Frequency:	GPRS/EDGE: 850: 824 MHz ~ 849MHz 1900: 1850 MHz ~ 1910MHz
Rx Frequency:	GPRS/EDGE: 850: 869 MHz ~ 894 MHz 1900: 1930 MHz ~ 1990MHz
Max Conducted Output Power:	GPRS850:33.23dBm, GPRS1900:30.41dBm EDGE 850:27.84dBm, EDGE 1900:26.72dBm
Type of Emission:	GPRS(850): 317KGXW; GPRS(1900): 317KGXW EDGE(850): 299KG7W; EDGE(1900): 316KG7W
Modulation Mode:	GMSK for GPRS; GMSK and 8PSK for EDGE
SIM Card:	Only support single SIM Card.
Antenna:	External Antenna The EUT doesn't have antenna, The adapter and antenna used for testing in this report is the after-market accessory
Antenna gain:	GPRS 850: 2.14dBi ,PCS 1900: 2.14dBi
Operating Voltage:	DC 3.8V
GPRS/EDGE Class:	Multi-Class12
Extreme Vol. Limits:	3.2V to 4.5V
Extreme Temp. Tolerance:	-40°C to +85°C
Hardware version number:	N/A
Software version number:	N/A



### 3 TEST CONFIGURATION OF EQUIPMENT UNDER TEST

Antenna port conducted and radiated test items were performed according to KDB 971168 D01 and ANSI C63.26 2015 Power Meas. License Digital Systems with maximum output power.

Radiated measurements were performed with rotating EUT in different three orthogonal test planes to find the maximum emission.

Radiated emissions were investigated as following frequency range:

1. 30 MHz to 10th harmonic for GSM850.
2. 30 MHz to 10th harmonic for GSM1900.

All modes and data rates and positions were investigated.

Test modes are chosen to be reported as the worst case configuration below:

BAND	TEST MODES AND CHANNELS	
	RADIATED TCS	CONDUCTED TCS
GSM 850 (824.2/836.6/848.8MHZ)	GPRS/EDGE CLASS 12 LINK	GPRS/EDGE CLASS 12 LINK
GSM 1900 (1850.2/1880/1909.8MHZ)	GPRS/EDGE CLASS 12 LINK	GPRS/EDGE CLASS 12 LINK





4 MEASUREMENT INSTRUMENTS

Radiation Test equipment

Kind of Equipment	Manufacturer	Type No.	Serial No.	Last calibration	Calibrated until
Test Receiver	R&S	ESCI	101427	2019.07.29	2020.07.28
Signal Analyzer	Agilent	N9020A	MY51110105	2019.03.02	2020.03.01
Wireless Communications Test Set	R&S	CMW 500	133884	2019.03.02	2020.03.01
Bilog Antenna	TESEQ	CBL6111D	34678	2017.11.02	2020.11.01
Horn Antenna	SCHWARZBECK	BBHA 9120D(1201)	9120D-1343	2018.10.19	2021.10.18
SHF-EHF Horn Antenna (18G-40GHz)	A-INFO	LB-180400-KF	J211020657	2018.03.11	2021.03.10
Pre-Amplifier (0.1M-3GHz)	EM	EM330	060665	2019.10.09	2020.10.08
Pre-Amplifier (1G-18GHz)	SKET	LNPA-01018G-45	SK2018080901	2019.10.12	2020.10.11
Turn table	EM	SC100_1	60531	N/A	N/A
Antenna mast	EM	SC100	N/A	N/A	N/A
Temperature & Humidity	HH660	Mieo	N/A	2019.10.12	2020.10.11
Test SW	BULUN	BL410-E/18.905			

RF Connected Test

Kind of Equipment	Manufacturer	Type No.	Serial No.	Last calibration	Calibrated until
Universal Radio communication tester	R&S	CMU200	11764	2019.10.11	2020.10.10
Wireless Communications Test Set	R&S	CMW 500	133884	2019.03.02	2020.03.01
Signal Analyzer	Agilent	N9020A	MY49100060	2019.10.09	2020.10.08
Temperature & Humidity	HH660	Mieo	N/A	2019.10.12	2020.10.11
Test SW	FARAD	LZ-RF /LzRf-3A3			

Equipment with a calibration date of "NCR" shown in this list was not used to make direct calibrated measurements.

5 TEST ITEMS

5.1 CONDUCTED OUTPUT POWER

TEST OVERVIEW

A system simulator was used to establish communication with the EUT. Its parameters were set to enforce EUT transmitting at the maximum power. The measured power in the radio frequency on the transmitter output terminals shall be reported.

TEST PROCEDURES

1. The transmitter output port was connected to the system simulator.
2. Set out at maximum power through the system simulator.
3. Select lowest, middle, and highest channels for each band and different modulation.
4. Measure and record the power level from the system simulator.
5. Limist

Operating band	FCC Limit	ISED Limit
GPRS/EDGE 850	ERP 7 watts	ERP 11.5 watts
GPRS/EDGE 1900	EIRP 2 watts	EIRP 2 watts

Note:  $ERP \text{ or } EIRP = P_{Meas} + G_T$

where

ERP or EIRP: effective radiated power or equivalent isotropically radiated power, respectively (expressed in the same units as  $P_{Meas}$ , e.g. dBm)

$P_{Meas}$ : measured transmitter output power, in dBm

$G_T$ : gain of the transmitting antenna, in dBd (ERP) or dBi (EIRP)

TEST SETUP

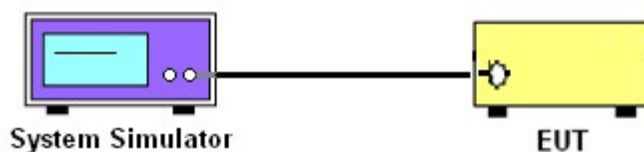

TEST RESULT

Note: Test data See Appendix 1.

## 5.2 PEAK TO AVERAGE RATIO

### TEST OVERVIEW

According to §24.232(d), power measurements for transmissions by stations authorized under this section may be made either in accordance with a commission-approved average power technique or in compliance with paragraph € of this section. In both instances, equipment employed must be authorized in accordance with the provisions of §24.51. In measuring transmissions in this band using an average power technique, the peak-to-average ratio (PAR) of the transmission may not exceed 13 db.

### TEST PROCEDURES

1. The testing follows FCC KDB 971168 D01 v03r01 Section 5.7 and ANSI C63.26 2015 Section 5.2.6
2. The eut was connected to the and peak and av system simulator& spectrum analysis reads
3. Select lowest, middle, and highest channels for each band and different modulation.
4. Set the test probe and measure average power of the spectrum analysis
5. Limist

Operating band	FCC Limit	ISED Limit
GPRS/EDGE 850	PAR ≤ 13 dB	PAR ≤ 13 dB
GPRS/EDGE 1900	PAR ≤ 13 dB	PAR ≤ 13 dB

### TEST SETUP

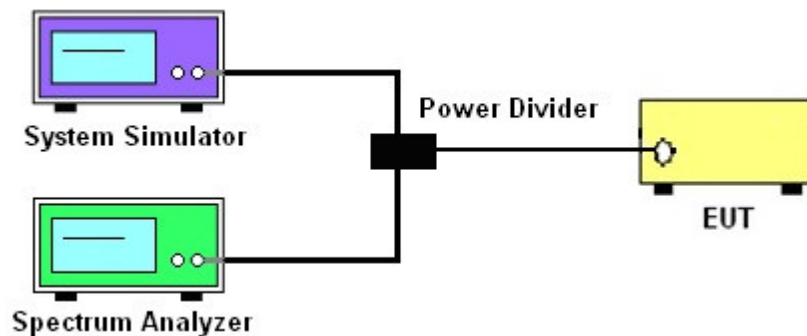

### TEST RESULT

Note: Test data See Appendix 2.

## 5.3 OCCUPIED BANDWIDTH

### TEST OVERVIEW

The occupied bandwidth, that is the frequency bandwidth such that, below its lower and above its upper frequency limits, the mean powers radiated are each equal to 0.5 percent of the total mean power radiated by a given emission shall be measured.

The 26 dB emission bandwidth is defined as the frequency range between two points, one above and one below the carrier frequency, at which the spectral density of the emission is attenuated 26 dB below the maximum in-band spectral density of the modulated signal. Spectral density (power per unit bandwidth) is to be measured with a detector of resolution bandwidth equal to approximately 1.0% of the emission bandwidth.

All modes of operation were investigated and the worst case configuration results are reported in this section.

### TEST PROCEDURE

1. The signal analyzer's automatic bandwidth measurement capability was used to perform the 99% occupied bandwidth and the 26dB bandwidth. The bandwidth measurement was not influenced by any intermediate power nulls in the fundamental emission.
2.  $RBW = 1 - 5\%$  of the expected OBW
3.  $VBW \geq 3 \times RBW$
4. Detector = Peak
5. Trace mode = max hold
6. Sweep = auto couple
7. The trace was allowed to stabilize
8. If necessary, steps 2 – 7 were repeated after changing the RBW such that it would be within 1 – 5% of the 99% occupied bandwidth observed in Step 7
9. Limit:N/A

### TEST SETUP

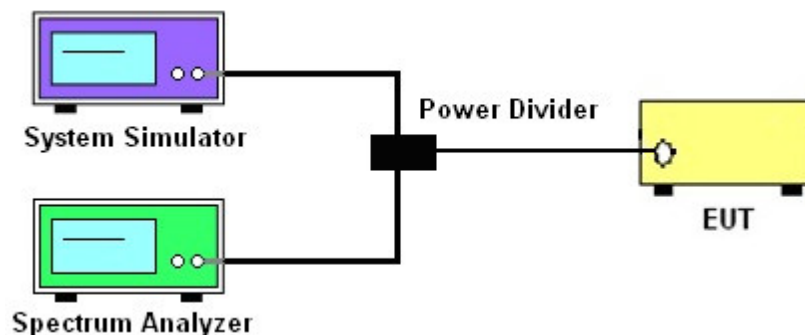

### TEST RESULT

Note: Test data See Appendix 3.

## 5.4 FREQUENCY STABILITY

### Test Overview

Frequency stability testing is performed in accordance with the guidelines of ANSI C63.26 2015. The frequency stability of the transmitter is measured by:

- a.) Temperature: The temperature is varied from  $-40^{\circ}\text{C}$  to  $+85^{\circ}\text{C}$  in  $10^{\circ}\text{C}$  increments using an environmental chamber.
- b.) Primary Supply Voltage: The primary supply voltage is varied from 85% to 115% of the nominal value for non hand-carried battery and AC powered equipment. For hand-carried, battery-powered equipment, primary supply voltage is reduced to the battery operating end point which shall be specified by the manufacturer.

For Part 22, the frequency stability of the transmitter shall be maintained within  $\pm 0.00025\%$  ( $\pm 2.5$  ppm) of the center frequency. For Part 24 the frequency stability shall be sufficient to ensure that the fundamental emission stays within the authorized frequency block.

### Test Procedure

#### Temperature Variation

1. The testing follows fccdb 971168 D01 section 9.
2. The EUT was set up in the thermal chamber and connected with the system simulator.
3. With power OFF, the temperature was decreased to  $-40^{\circ}\text{C}$  and the EUT was stabilized before testing. Power was applied and the maximum change in frequency was recorded within one minute.
4. With power OFF, the temperature was raised in  $10^{\circ}\text{C}$  steps up to  $86^{\circ}\text{C}$ . The EUT was stabilized at each step for at least half an hour. Power was applied and the maximum frequency change was recorded within one minute.

#### Voltage Variation

1. The testing follows FCC KDB 971168 D01 Section 9.0.
2. The EUT was placed in a temperature chamber at  $25\pm 5^{\circ}\text{C}$  and connected with the system simulator.
3. The power supply voltage to the EUT was varied from 85% to 115% of the nominal value measured at the input to the EUT.
4. The variation in frequency was measured for the worst case.

### TEST SETUP

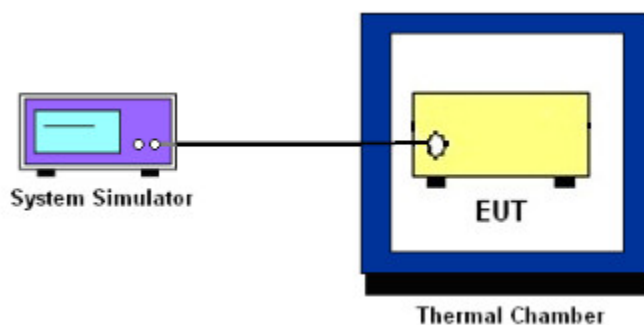

### TEST RESULT

Note: Test data See Appendix 4.

## 5.5 SPURIOUS EMISSIONS AT ANTENNA TERMINALS

### TEST OVERVIEW

The power of any emission outside of the authorized operating frequency ranges must be lower than the transmitter power (P) by a factor of at least  $43 + 10 \log (P)$  dB.

It is measured by means of a calibrated spectrum analyzer and scanned from 30 MHz up to a frequency including its 10th harmonic.

### TEST PROCEDURE

1. The testing FCC KDB 971168 D01 v03r01 Section 6.0. and ANSI C63.26-2015-Section 5.7.
2. The EUT was connected to the spectrum analyzer and system simulator via a power divider.
3. The RF output of EUT was connected to the spectrum analyzer by an RF cable and attenuator. The path loss was compensated to the results for each measurement.
4. The middle channel for the highest RF power within the transmitting frequency was measured.
5. The conducted spurious emission for the whole frequency range was taken.
6. The RF fundamental frequency should be excluded against the limit line in the operating frequency band.

#### 7. Limit

Operating band	FCC Limit	ISED Limit
GPRS/EDGE 850	< - 13 dBm /100kHz@ < 1GHz < - 13 dBm /1MHz@ > 1GHz	< - 13 dBm / 100 kHz
GPRS/EDGE 1900	< - 13 dBm /1MHz	< - 13 dBm /1MHz

8. The limit line is derived from  $43 + 10\log(P)$  dB below the transmitter power P(Watts)

$$= P(W) - [43 + 10\log(P)] \text{ (dB)}$$

$$= [30 + 10\log(P)] \text{ (dBm)} - [43 + 10\log(P)] \text{ (dB)}$$

$$= -13\text{dBm.}$$

### TEST SETUP

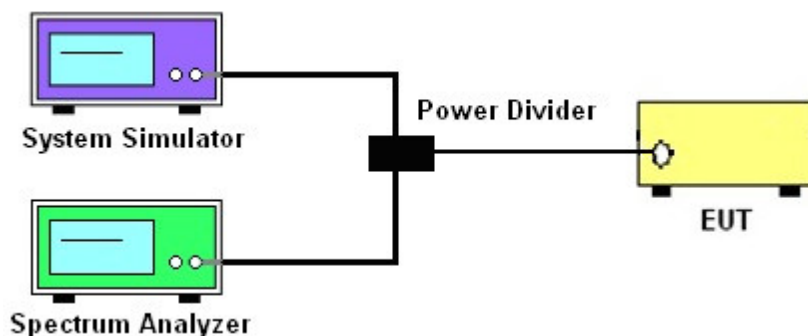

### TEST RESULT

Note: Test data See Appendix 5.

**5.6 BAND EDGE OVERVIEW**

All out of band emissions are measured with a spectrum analyzer connected to the antenna terminal of the EUT while the EUT is operating at maximum power, and at the appropriate frequencies. All data rates were investigated to determine the worst case configuration. All modes of operation were investigated and the worst case configuration results are reported in this section.

The minimum permissible attenuation level of any spurious emission is  $43 + \log_{10}(P[\text{Watts}])$ , where P is the transmitter power in Watts.

**TEST PROCEDURE**

1. The testing FCC KDB 971168 D01 v03r01 Section 6.0. and ANSI C63.26-2015-Section 5.7
2. Start and stop frequency were set such that the band edge would be placed in the center of the Plot.
3. The EUT was connected to the spectrum analyzer and system simulator via a power divider.
4. The RF output of EUT was connected to the spectrum analyzer by an RF cable and attenuator. The path loss was compensated to the results for each measurement.
5. The band edges of low and high channels for the highest RF powers were measured.
6. The RF fundamental frequency should be excluded against the limit line in the operating frequency band.
7. Limit

Operating band	FCC Limit	ISED Limit
GPRS/EDGE 850	< - 13 dBm /1%EBW	< - 13 dBm / 1%OBW
GPRS/EDGE 1900	< - 13 dBm /1%EBW	< - 13 dBm / 1%OBW

8.The limit line is derived from  $43 + 10\log(P)$  dB below the transmitter power P(Watts)  
 $= P(W) - [43 + 10\log(P)]$  (dB)  
 $= [30 + 10\log(P)]$  (dBm) -  $[43 + 10\log(P)]$  (dB)  
 $= -13\text{dBm}$ .

**TEST SETUP**

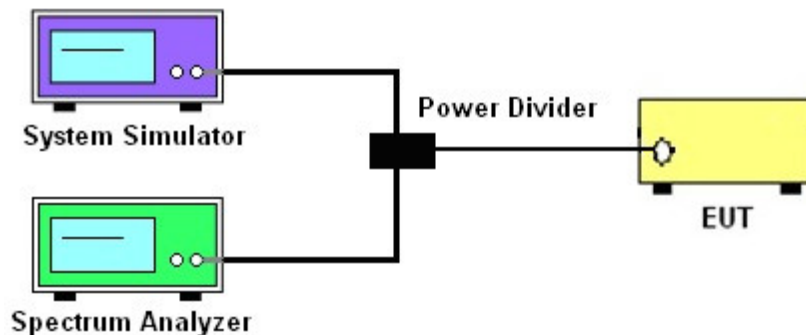

**TEST RESULT**

Note: Test data See Appendix 6.



5.7 FIELD STRENGTH OF SPURIOUS RADIATION MEASUREMENT TEST OVERVIEW

Radiated spurious emissions measurements are performed using the substitution method described in ANSI C63.26-2015 with the EUT transmitting into an integral antenna. Measurements on signals operating below 1GHz are performed using horizontally and vertically polarized tuned dipole antennas. Measurements on signals operating above 1GHz are performed using vertically and horizontally polarized horn antennas. All measurements are performed as peak measurements while the EUT is operating at maximum power and at the appropriate frequencies.

It is measured by means of a calibrated spectrum analyzer and scanned from 30 MHz up to a frequency including its 10th harmonic.

Note: The radiated spurious emissions which are attenuated more than 20 dB below the permissible Value for above 18GHz, so it's don't need not be reported.

TEST PROCEDURE

- 1. The testing FCC KDB 971168 D01 Section 7 and ANSI C63.26-2015-Section 5.5.
2. RBW = 100kHz for emissions below 1GHz and 1MHz for emissions above 1GHz
3. VBW ≥ 3 x RBW
4. Span = 1.5 times the OBW
5.No. of sweep points > 2 x span/RBW
6. Detector = Peak
7. Trace mode = max hold
8. The trace was allowed to stabilize
9. Effective Isotropic Spurious Radiation was measured by substitution method according to TIA/EIA-603-D. The EUT was replaced by the substitution antenna at same location, and then a known power from S.G. was applied into the dipole antenna through a Tx cable, and then recorded the maximum Analyzer reading through raised and lowered the test antenna. The correction factor (in dB) = S.G. - Tx Cable loss + Substitution antenna gain - Analyzer reading. Then the EUT's EIRP/ERP was calculated with the correction factor, ERP/EIRP = P.SG + GT - LC
ERP/EIRP = effective or equivalent radiated power, respectively (expressed in the same units as PMeas, typically dBW or dBm);
P.SG = measured transmitter output power or PSD, in dBm or dBW;
GT = gain of the transmitting antenna, in dBd (ERP) or dBi (EIRP);
LC = signal attenuation in the connecting cable between the transmitter and antenna, in dB.

10. Limit

Table with 3 columns: Operating band, FCC Limit, ISED Limit. Rows include GPRS/EDGE 850 and GPRS/EDGE 1900.



## TEST SETUP

For radiated test from 30MHz to 1GHz

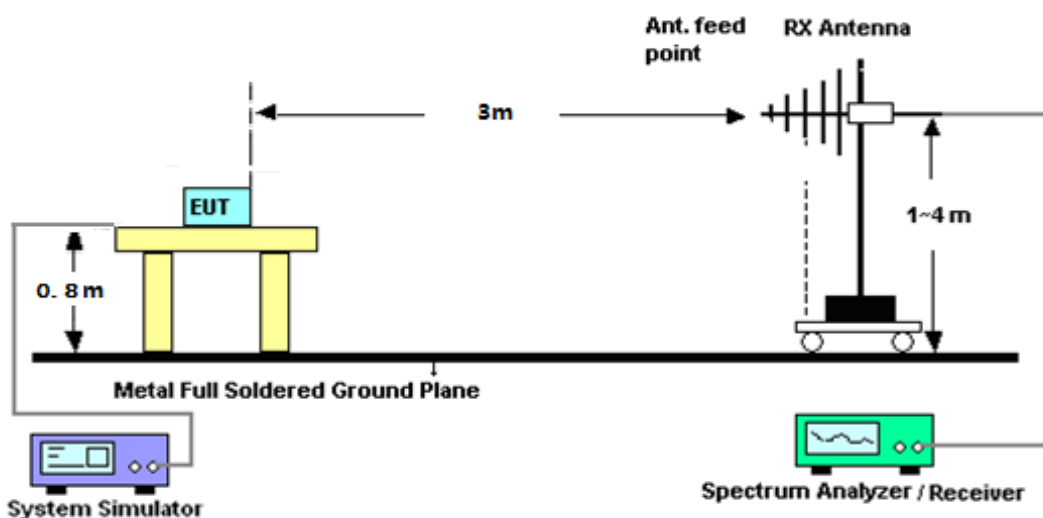

For radiated test from above 1GHz

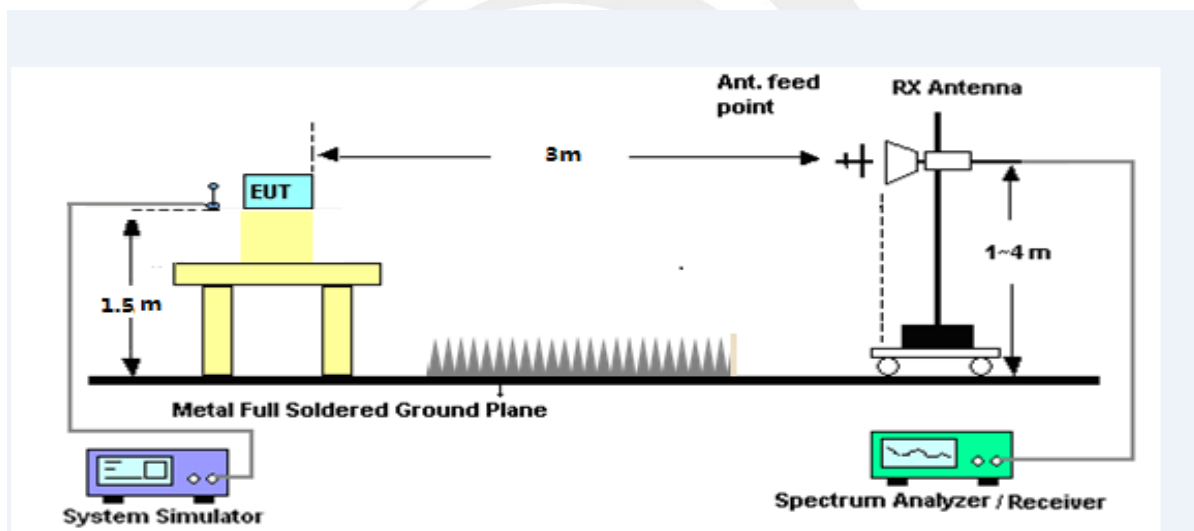

## TEST RESULT

Note: Test data See Appendix 7.



## 5.8 MODULATION CHARACTERISTICS

### TEST LIMIT

Other types of equipment”, the use of higher order modulations such as OFDM or LTE or other modulation are acceptable for use.

Result: PASS

Note: The device implement digital modulation such as GMSK and 8PSK, hence the EUT is deemed to comply with this requirement without additional testing.





APPENDIX A.TESTRESULT  
A1.CONDUCTED OUTPUT POWER

Band	Channel	PCL	Slot	Power(dBm)	EIRP (dBm)   (watts)		Limit (watts) FCC   IC		Verdict
GPRS850	128	3	1	32.89	35.03	3.18	7	11.5	PASS
GPRS850	128	3	2	31.87	34.01	2.52	7	11.5	PASS
GPRS850	128	3	3	29.91	32.05	1.60	7	11.5	PASS
GPRS850	128	3	4	27.46	29.60	0.91	7	11.5	PASS
GPRS850	190	3	1	33.14	35.28	3.37	7	11.5	PASS
GPRS850	190	3	2	31.68	33.82	2.41	7	11.5	PASS
GPRS850	190	3	3	29.42	31.56	1.43	7	11.5	PASS
GPRS850	190	3	4	27.15	29.29	0.85	7	11.5	PASS
GPRS850	251	3	1	33.23	35.37	3.44	7	11.5	PASS
GPRS850	251	3	2	31.67	33.81	2.40	7	11.5	PASS
GPRS850	251	3	3	29.15	31.29	1.35	7	11.5	PASS
GPRS850	251	3	4	27.67	29.81	0.96	7	11.5	PASS

Band	Channel	PCL	Slot	Power(dBm)	EIRP (dBm)   (watts)		Limit (watts) FCC   IC		Verdict
EGPRS850(8PSK)	128	3	1	27.31	29.45	0.88	7	11.5	PASS
EGPRS850(8PSK)	128	3	2	27.52	29.66	0.92	7	11.5	PASS
EGPRS850(8PSK)	128	3	3	27.04	29.18	0.83	7	11.5	PASS
EGPRS850(8PSK)	128	3	4	26.08	28.22	0.66	7	11.5	PASS
EGPRS850(8PSK)	190	3	1	27.08	29.22	0.84	7	11.5	PASS
EGPRS850(8PSK)	190	3	2	27.11	29.25	0.84	7	11.5	PASS
EGPRS850(8PSK)	190	3	3	27.67	29.81	0.96	7	11.5	PASS
EGPRS850(8PSK)	190	3	4	26.74	28.88	0.77	7	11.5	PASS
EGPRS850(8PSK)	251	3	1	27.17	29.31	0.85	7	11.5	PASS
EGPRS850(8PSK)	251	3	2	27.34	29.48	0.89	7	11.5	PASS
EGPRS850(8PSK)	251	3	3	27.84	29.98	1.00	7	11.5	PASS
EGPRS850(8PSK)	251	3	4	26.84	28.98	0.79	7	11.5	PASS



Band	Channel	PCL	Slot	Power(dBm)	EIRP		Limit (watts)	Verdict
					(dBm)	(watts)		
GPRS1900	512	0	1	29.91	32.05	1.60	2	PASS
GPRS1900	512	0	2	29.71	31.85	1.53	2	PASS
GPRS1900	512	0	3	29.56	31.70	1.48	2	PASS
GPRS1900	512	0	4	28.34	30.48	1.12	2	PASS
GPRS1900	661	0	1	30.26	32.40	1.74	2	PASS
GPRS1900	661	0	2	30.41	32.55	1.80	2	PASS
GPRS1900	661	0	3	29.26	31.40	1.38	2	PASS
GPRS1900	661	0	4	28.98	31.12	1.29	2	PASS
GPRS1900	810	0	1	30.21	32.35	1.72	2	PASS
GPRS1900	810	0	2	30.15	32.29	1.69	2	PASS
GPRS1900	810	0	3	29.04	31.18	1.31	2	PASS
GPRS1900	810	0	4	28.83	30.97	1.25	2	PASS

Band	Channel	PCL	Slot	Power(dBm)	EIRP		Limit (watts)	Verdict
					(dBm)	(watts)		
EGPRS1900(8PSK)	512	2	1	26.40	28.54	0.71	2	PASS
EGPRS1900(8PSK)	512	2	2	26.25	28.39	0.69	2	PASS
EGPRS1900(8PSK)	512	2	3	26.12	28.26	0.67	2	PASS
EGPRS1900(8PSK)	512	2	4	26.22	28.36	0.69	2	PASS
EGPRS1900(8PSK)	661	2	1	26.46	28.60	0.72	2	PASS
EGPRS1900(8PSK)	661	2	2	26.14	28.28	0.67	2	PASS
EGPRS1900(8PSK)	661	2	3	26.20	28.34	0.68	2	PASS
EGPRS1900(8PSK)	661	2	4	26.00	28.14	0.65	2	PASS
EGPRS1900(8PSK)	810	2	1	26.72	28.86	0.77	2	PASS
EGPRS1900(8PSK)	810	2	2	26.53	28.67	0.74	2	PASS
EGPRS1900(8PSK)	810	2	3	26.44	28.58	0.72	2	PASS
EGPRS1900(8PSK)	810	2	4	26.30	28.44	0.70	2	PASS



## A2. PEAK-TO-AVERAGE RADIO

Band	Channel	Peak-to-Average Ratio(dB)	Limit(dBm)	Verdict
GPRS 850	128	0.19	13	PASS
	190	0.20	13	PASS
	251	0.22	13	PASS
EGPRS 850(8PSK)	128	3.21	13	PASS
	190	3.36	13	PASS
	251	3.41	13	PASS
GPRS1900	512	7.83	13	PASS
	661	7.80	13	PASS
	810	7.83	13	PASS
EGPRS1900(8PSK)	512	11.07	13	PASS
	661	10.58	13	PASS
	810	10.72	13	PASS





## A3. OCCUPIED BANDWIDTH (99% OCCUPIED BANDWIDTH/26dB BANDWIDTH)

Band	Channel	Occupied Bandwidth (kHz)	26dB Bandwidth (kHz)	Verdict
GPRS 850	128	245.87	312.4	PASS
	190	246.32	311.6	PASS
	251	245.02	317.2	PASS
EGPRS 850(8PSK)	128	248.06	299.4	PASS
	190	245.66	298.8	PASS
	251	240.95	281.4	PASS
GPRS1900	512	246.02	317.39	PASS
	661	246.02	317.39	PASS
	810	246.02	315.94	PASS
EGPRS1900(8PSK)	512	247.47	313.04	PASS
	661	246.02	315.94	PASS
	810	247.47	311.59	PASS



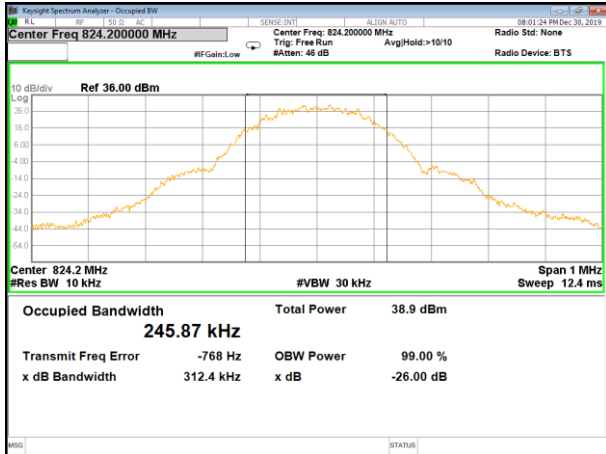

GPRS\_850\_Lower\_26BW and 99%

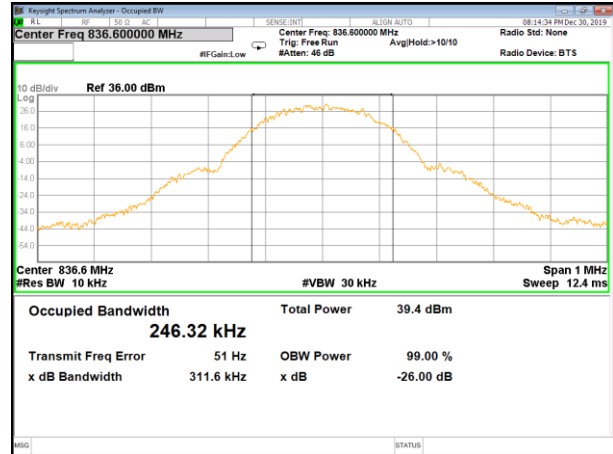

GPRS\_850\_Middle\_26BW and 99%

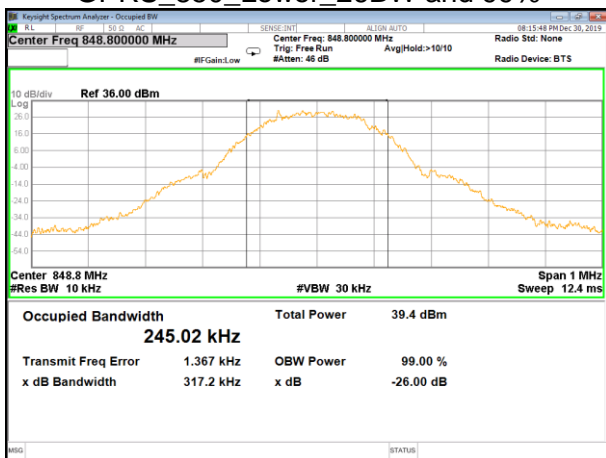

GPRS\_850\_Higher\_26BW and 99%

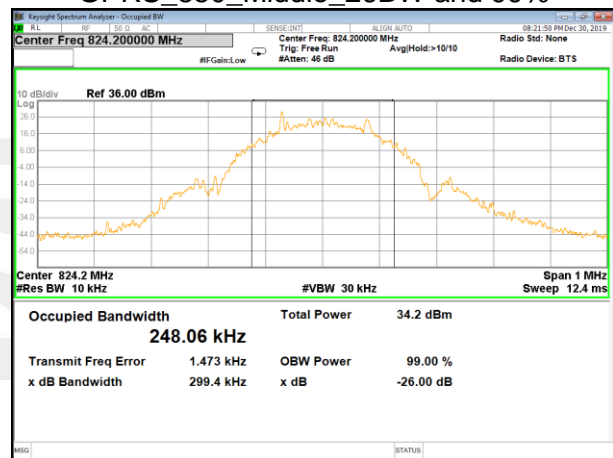

EGPRS(8PSK)\_850\_Lower\_26BW and 99%

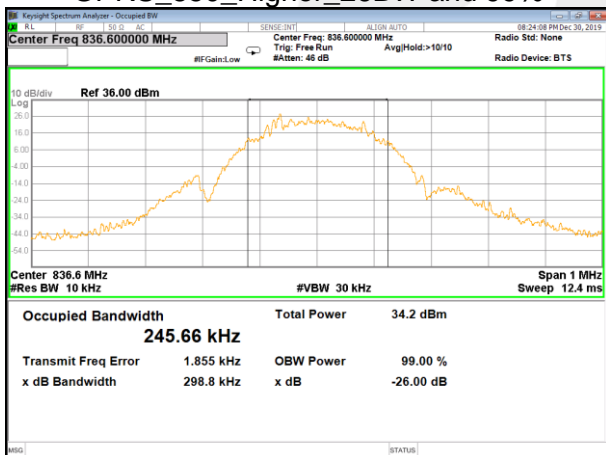

EGPRS(8PSK)\_850\_Middle\_26BW and 99%

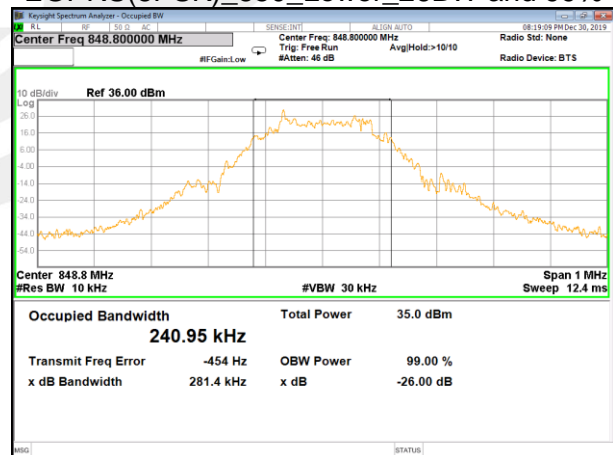

EGPRS(8PSK)\_850\_Higher\_26BW and 99%

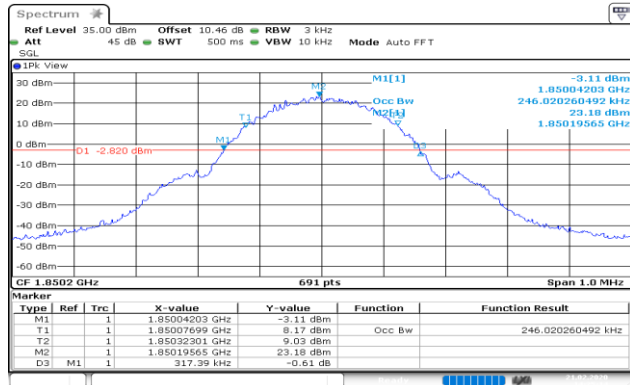

Date: 21.FEB.2020 14:25:14

GPRS\_1900\_Lower\_26BW and 99%

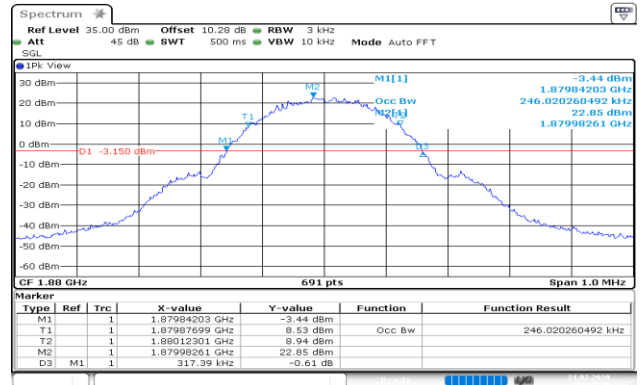

Date: 21.FEB.2020 14:25:36

GPRS\_1900\_Middle\_26BW and 99%

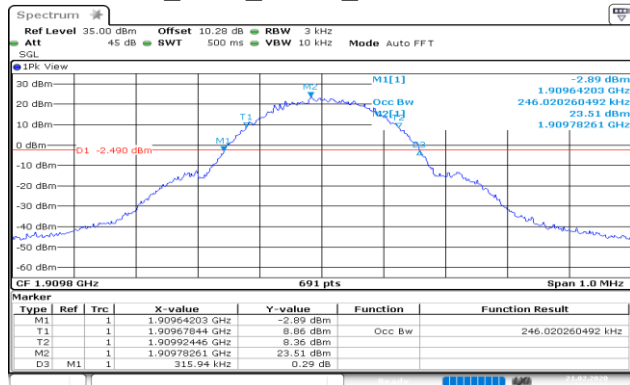

Date: 21.FEB.2020 14:25:59

GPRS\_1900\_Higher\_26BW and 99%

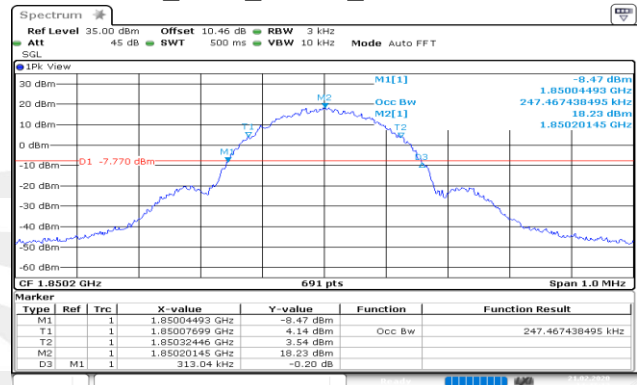

Date: 21.FEB.2020 14:47:12

EGPRS(8PSK)\_1900\_Lower\_26BW and 99%

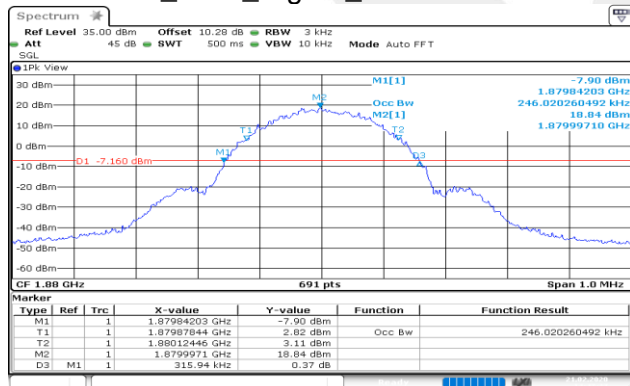

Date: 21.FEB.2020 14:47:37

EGPRS(8PSK)\_1900\_Middle\_26BW and 99%

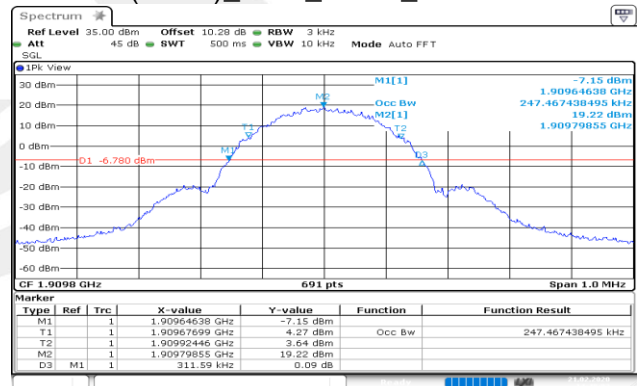

Date: 21.FEB.2020 14:48:02

EGPRS(8PSK)\_1900\_Higher\_26BW and 99%





A4.FREQUENCY STABILITY

Reference Frequency(Middle Channel): GPRS 836.6MHz			
Environment Temperature (°C)	Power Supplied (VDC)	Frequency Measure with Time Elapsed	
		Deviation Frequency (Hz)	within 836.6MHz±2.5ppm (Hz)
25	3.2	21.95	±2091.5
	3.8	37.68	±2091.5
	4.5	37.35	±2091.5
Reference Frequency(Middle Channel): GPRS 1880 MHz			
Environment Temperature (°C)	Power Supplied (VDC)	Frequency Measure with Time Elapsed	
		Deviation Frequency (Hz)	within 1880MHz±2.5ppm (Hz)
25	3.2	22.41	±4700
	3.8	19.79	±4700
	4.5	12.20	±4700
Reference Frequency(Middle Channel): EDGE 836.6MHz			
Environment Temperature (°C)	Power Supplied (VDC)	Frequency Measure with Time Elapsed	
		Deviation Frequency (Hz)	within 836.6MHz±2.5ppm (Hz)
25	3.2	4.62	±2091.5
	3.8	11.78	±2091.5
	4.5	23.76	±2091.5
Reference Frequency(Middle Channel): EDGE 1880 MHz			
Environment Temperature (°C)	Power Supplied (VDC)	Frequency Measure with Time Elapsed	
		Deviation Frequency (Hz)	within 1880MHz±2.5ppm (Hz)
25	3.2	19.53	±4700
	3.8	27.28	±4700
	4.5	41.33	±4700



## GPRS850

Reference Frequency(Middle Channel): 836.6MHz			
Environment Temperature (°C)	Power Supplied (VDC)	Frequency Measure with Time Elapsed	
		Deviation Frequency (Hz)	within 836.6MHz±2.5ppm (Hz)
85	3.8	39.55	±2091.5
80	3.8	30.12	±2091.5
70	3.8	43.46	±2091.5
60	3.8	39.07	±2091.5
50	3.8	27.67	±2091.5
40	3.8	36.68	±2091.5
30	3.8	34.38	±2091.5
20	3.8	25.47	±2091.5
10	3.8	31.32	±2091.5
0	3.8	30.41	±2091.5
-10	3.8	22.21	±2091.5
-20	3.8	28.64	±2091.5
-30	3.8	31.93	±2091.5
-40	3.8	4.97	±2091.5

## GPRS1900

Reference Frequency(Middle Channel): 1880 MHz			
Environment Temperature (°C)	Power Supplied (VDC)	Frequency Measure with Time Elapsed	
		Deviation Frequency (Hz)	within 1880MHz±2.5ppm (Hz)
85	3.8	15.69	±4700
80	3.8	1.49	±4700
70	3.8	7.46	±4700
60	3.8	12.79	±4700
50	3.8	17.60	±4700
40	3.8	5.88	±4700
30	3.8	5.52	±4700
20	3.8	10.36	±4700
10	3.8	12.17	±4700
0	3.8	14.75	±4700
-10	3.8	16.27	±4700
-20	3.8	15.34	±4700
-30	3.8	16.34	±4700
-40	3.8	18.98	±4700





## EDGE850

Reference Frequency(Middle Channel): 836.6MHz			
Environment Temperature (°C)	Power Supplied (VDC)	Frequency Measure with Time Elapsed	
		Deviation Frequency (Hz)	within 836.6MHz±2.5ppm (Hz)
85	3.8	22.63	±2091.5
80	3.8	25.18	±2091.5
70	3.8	24.38	±2091.5
60	3.8	21.18	±2091.5
50	3.8	22.89	±2091.5
40	3.8	24.67	±2091.5
30	3.8	25.31	±2091.5
20	3.8	31.03	±2091.5
10	3.8	31.83	±2091.5
0	3.8	27.06	±2091.5
-10	3.8	23.31	±2091.5
-20	3.8	28.35	±2091.5
-30	3.8	36.61	±2091.5
-40	3.8	27.38	±2091.5

## EDGE1900

Reference Frequency(Middle Channel): 1880 MHz			
Environment Temperature (°C)	Power Supplied (VDC)	Frequency Measure with Time Elapsed	
		Deviation Frequency (Hz)	within 1880MHz±2.5ppm (Hz)
85	3.8	34.58	±4700
80	3.8	25.41	±4700
70	3.8	25.18	±4700
60	3.8	24.34	±4700
50	3.8	22.86	±4700
40	3.8	36.16	±4700
30	3.8	25.22	±4700
20	3.8	18.92	±4700
10	3.8	5.71	±4700
0	3.8	6.59	±4700
-10	3.8	11.62	±4700
-20	3.8	13.66	±4700
-30	3.8	12.01	±4700



-40	3.8	9.30	±4700
-----	-----	------	-------





### A5. SPURIOUS EMISSIONS AT ANTENNA TERMINALS

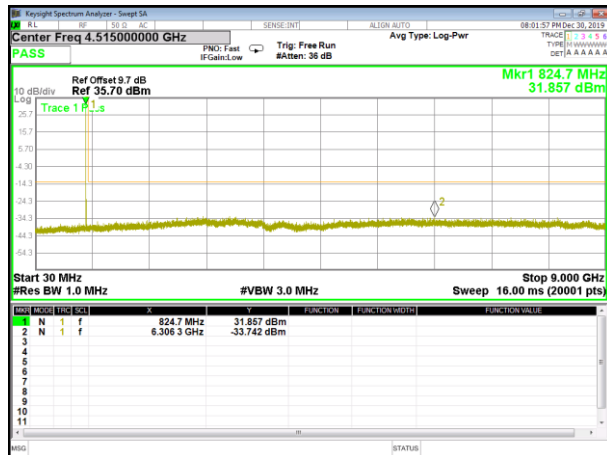

GPRS\_850\_Lower\_Conducted Spurious

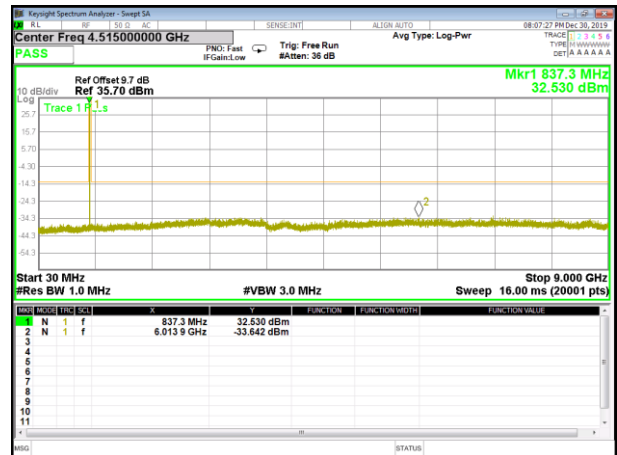

GPRS\_850\_Middle\_Conducted Spurious

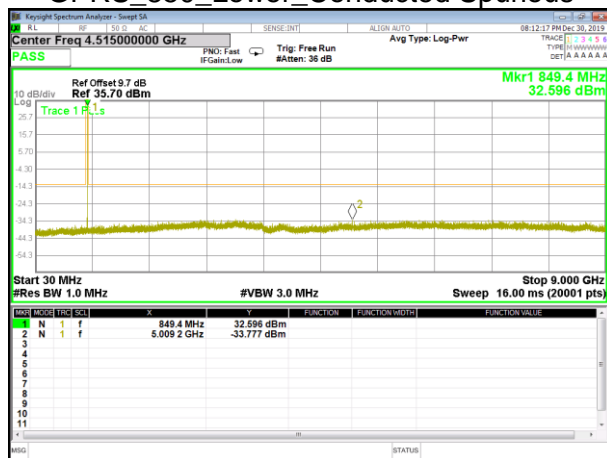

GPRS\_850\_Higher\_Conducted Spurious

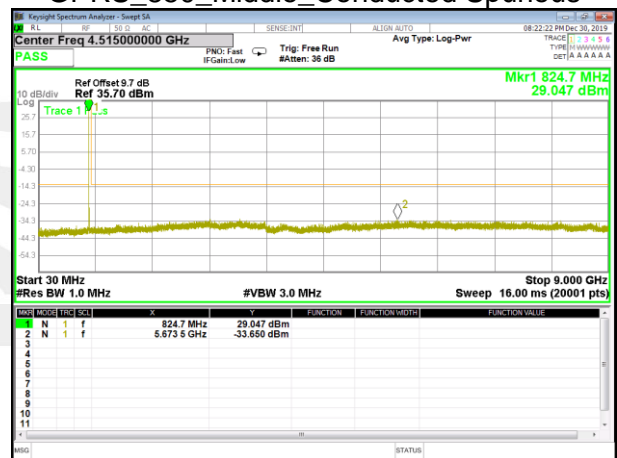

EGPRS(8PSK)\_850\_Lower\_Conducted Spurious

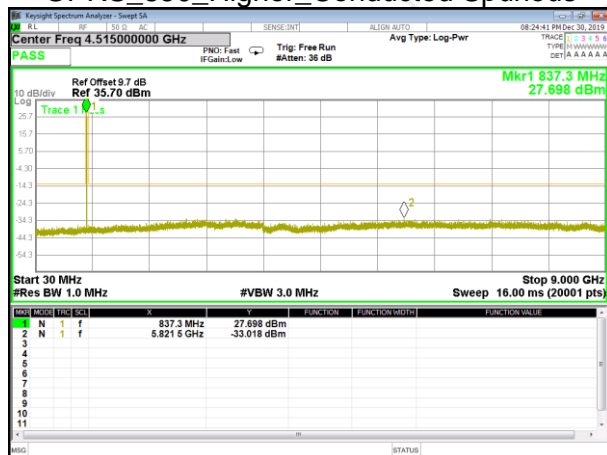

EGPRS(8PSK)\_850\_Middle\_Conducted Spurious

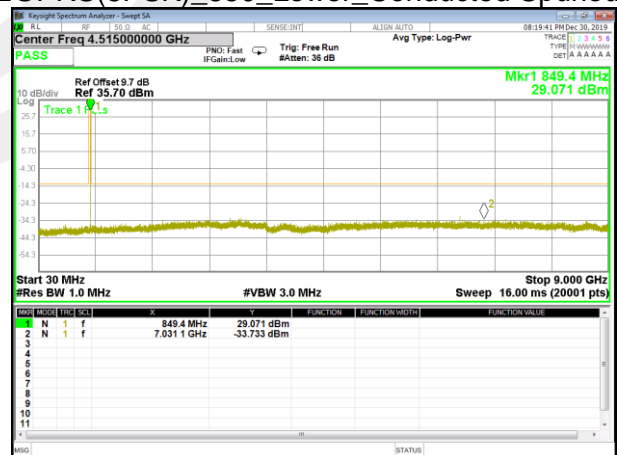

EGPRS(8PSK)\_850\_Higher\_Conducted Spurious

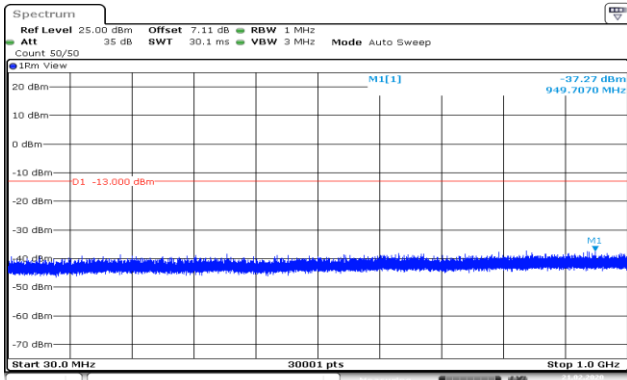

Date: 21.FEB.2020 14:12:35

GPRS\_1900\_Lower(30MHz-1GHz)

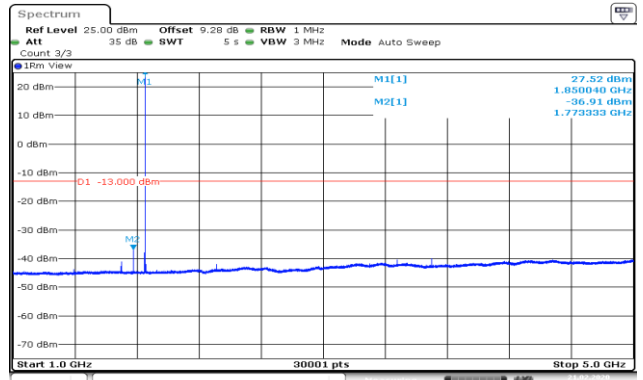

Date: 21.FEB.2020 14:28:33

GPRS\_1900\_Lower(1GHz-5GHz)

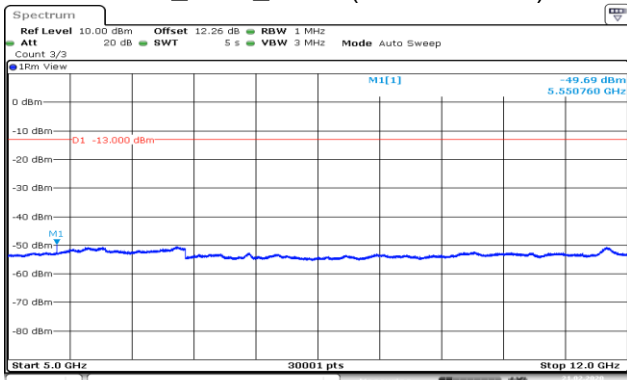

Date: 21.FEB.2020 14:12:30

GPRS\_1900\_Lower(5GHz-12GHz)

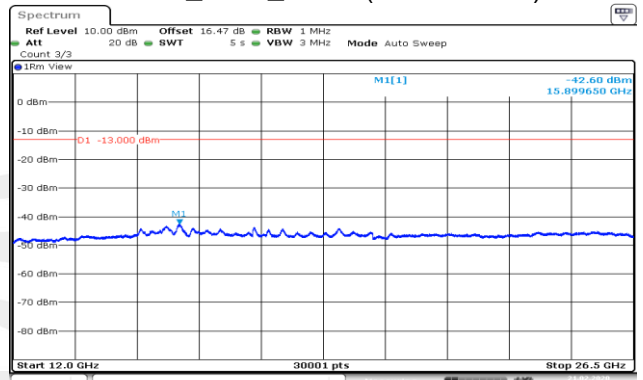

Date: 21.FEB.2020 14:30:25

GPRS\_1900\_Lower(12GHz-26.5GHz)

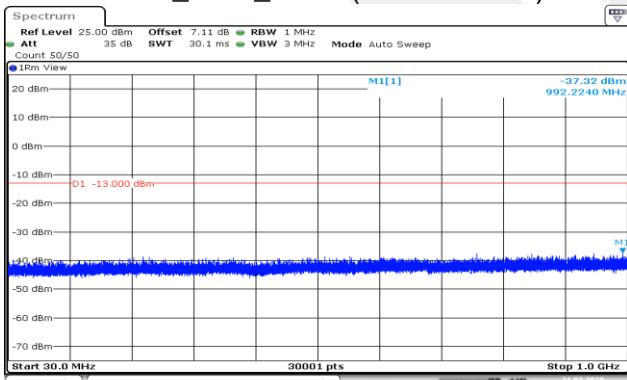

Date: 21.FEB.2020 14:30:45

GPRS\_1900\_Middle(30MHz-1GHz)

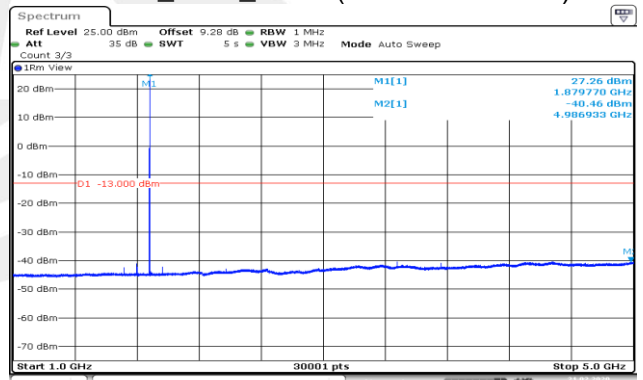

Date: 21.FEB.2020 14:31:43

GPRS\_1900\_Middle(1GHz-5GHz)

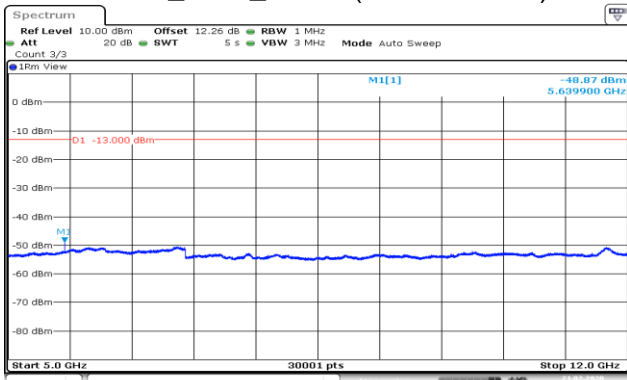

Date: 21.FEB.2020 14:32:47

GPRS\_1900\_Middle(5GHz-12GHz)

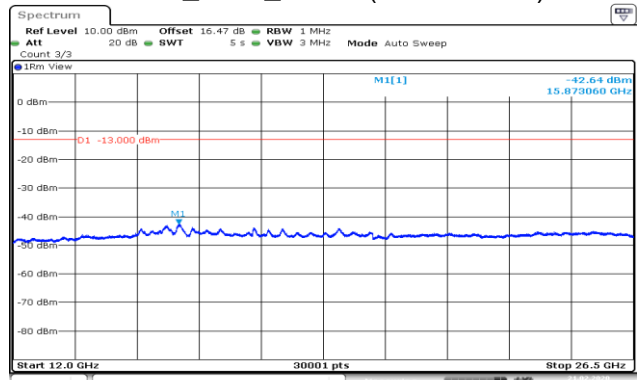

Date: 21.FEB.2020 14:33:42

GPRS\_1900\_Middle(12GHz-26.5GHz)

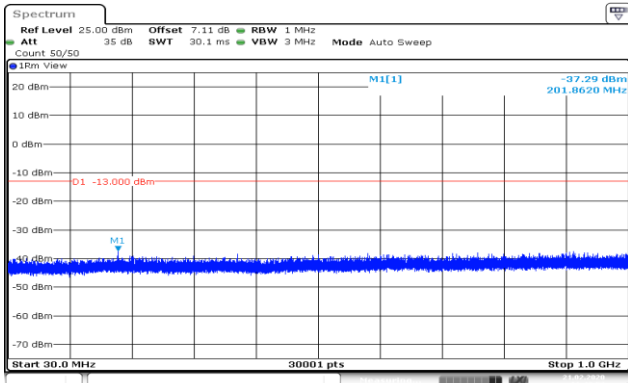

Date: 21.FEB.2020 11:43:54

GPRS\_1900\_Higher(30MHz-1GHz)

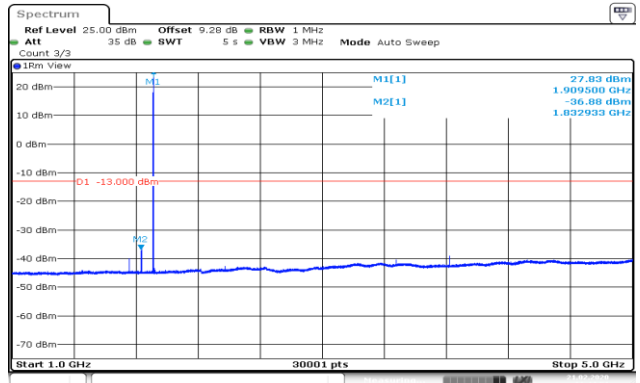

Date: 21.FEB.2020 11:44:52

GPRS\_1900\_Higher(1GHz-5GHz)

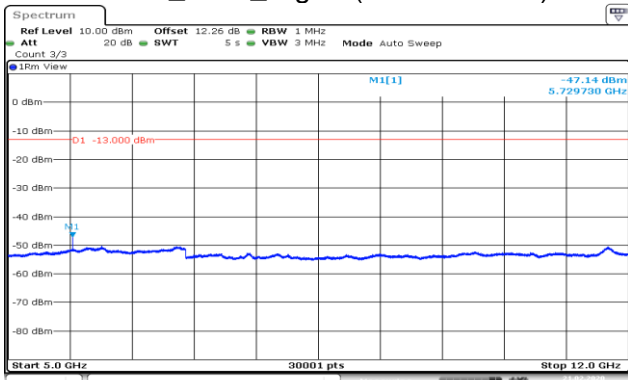

Date: 21.FEB.2020 11:45:49

GPRS\_1900\_Higher(5GHz-12GHz)

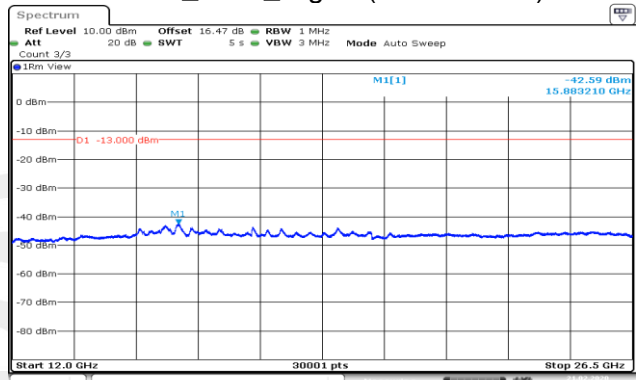

Date: 21.FEB.2020 11:46:44

GPRS\_1900\_Higher(12GHz-26.5GHz)



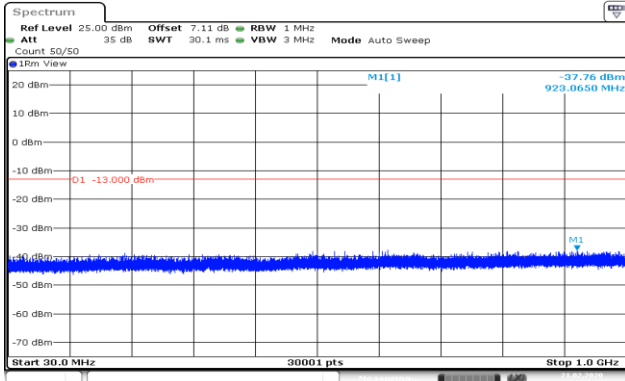

Date: 21.FEB.2020 14:49:48

EGPRS\_1900(8PSK)\_Lower(30MHz-1GHz)

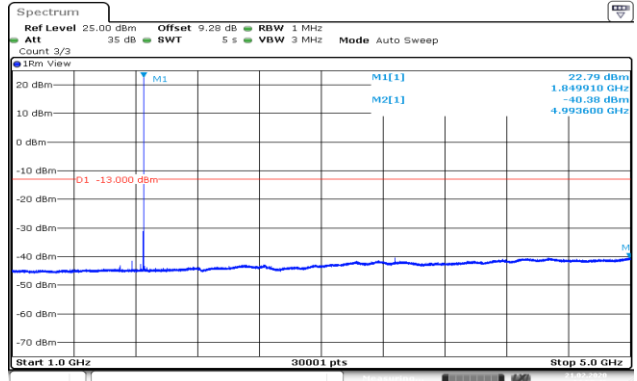

Date: 21.FEB.2020 14:50:46

EGPRS\_1900(8PSK)\_Lower(1GHz-5GHz)

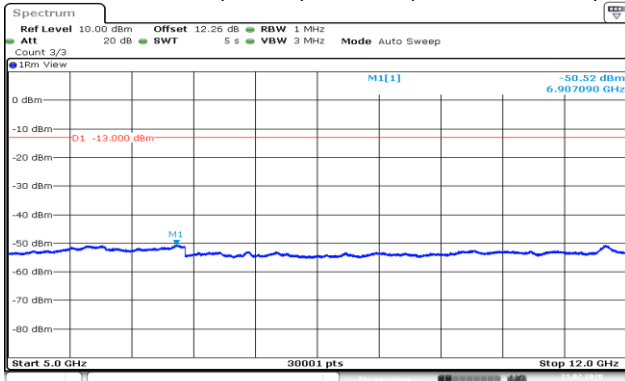

Date: 21.FEB.2020 14:51:43

EGPRS\_1900(8PSK)\_Lower(5GHz-12GHz)

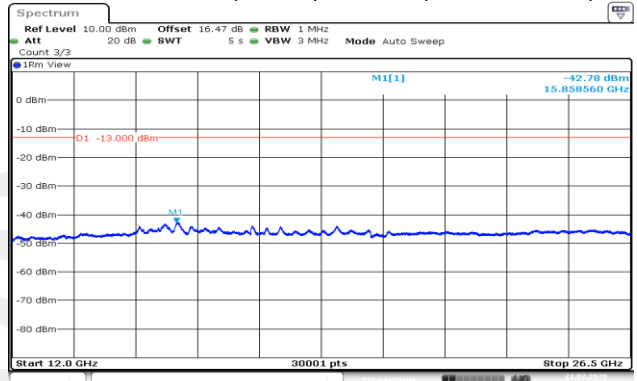

Date: 21.FEB.2020 14:52:38

EGPRS\_1900(8PSK)\_Lower(12GHz-26.5GHz)

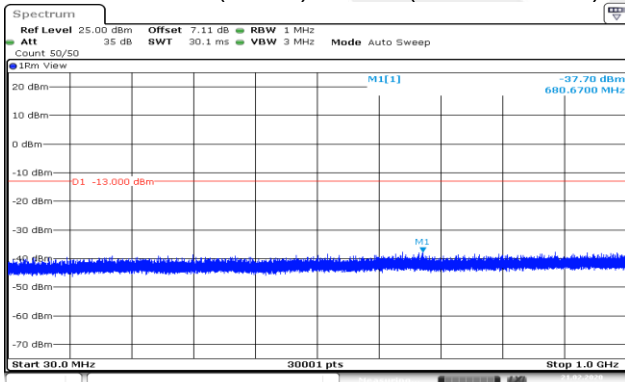

Date: 21.FEB.2020 14:53:02

EGPRS\_1900(8PSK)\_Middle(30MHz-1GHz)

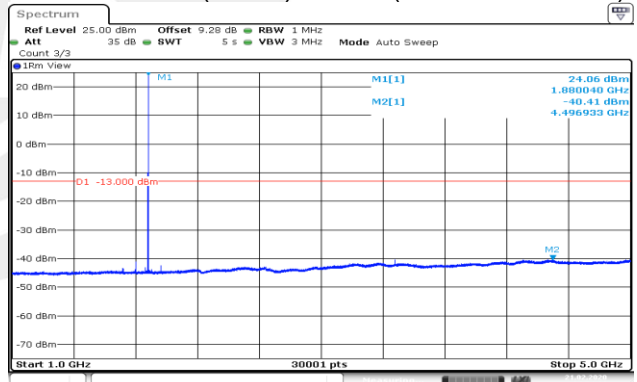

Date: 21.FEB.2020 14:54:00

EGPRS\_1900(8PSK)\_Middle(1GHz-5GHz)

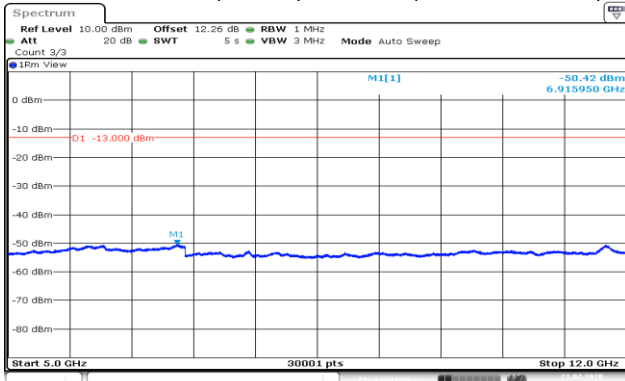

Date: 21.FEB.2020 14:54:57

EGPRS\_1900(8PSK)\_Middle(5GHz-12GHz)

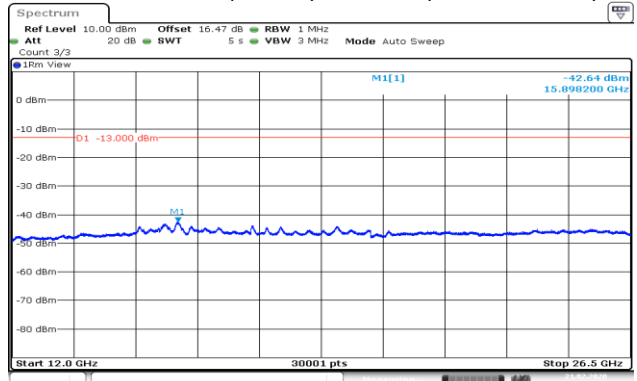

Date: 21.FEB.2020 14:55:59

EGPRS\_1900(8PSK)\_Middle(12GHz-26.5GHz)

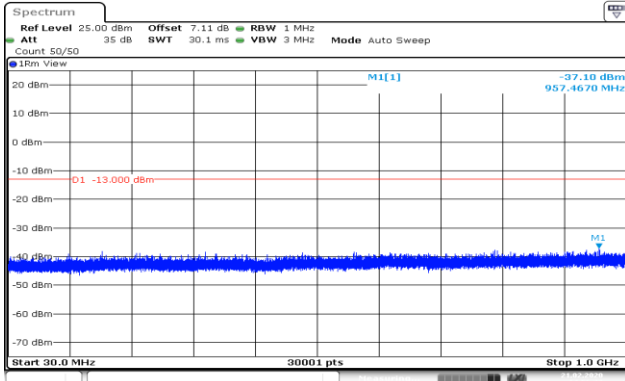

Date: 21.FEB.2020 14:15:23

EGPRS\_1900(8PSK)\_Higher(30MHz-1GHz)

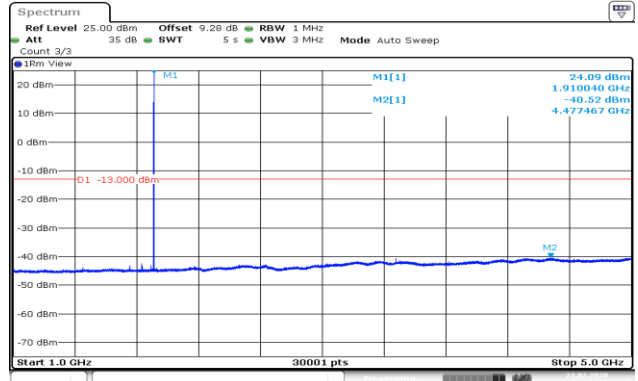

Date: 21.FEB.2020 14:15:21

EGPRS\_1900(8PSK)\_Higher(1GHz-5GHz)

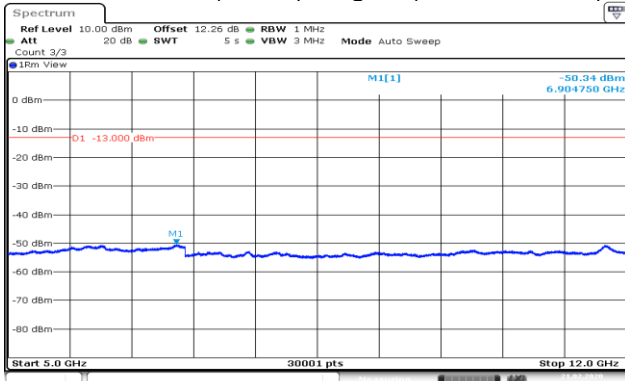

Date: 21.FEB.2020 14:15:18

EGPRS\_1900(8PSK)\_Higher(5GHz-12GHz)

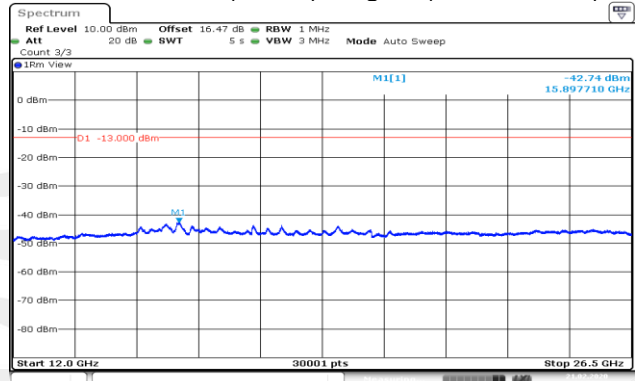

Date: 21.FEB.2020 14:15:13

EGPRS\_1900(8PSK)\_Higher(12GHz-26.5GHz)



### A6. BAND EDGE

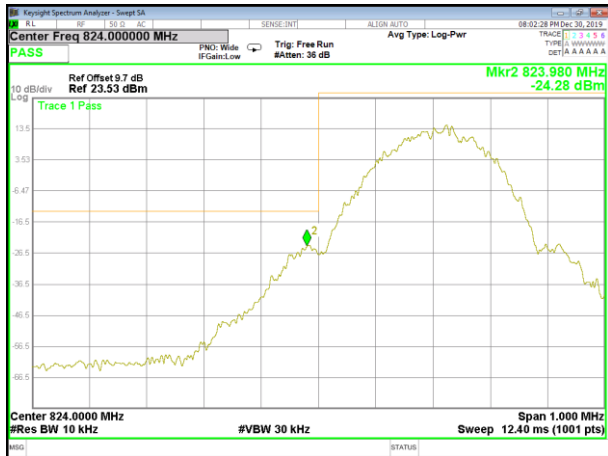

GPRS\_850\_Lower\_Band edge



GPRS\_850\_Higher\_Band edge

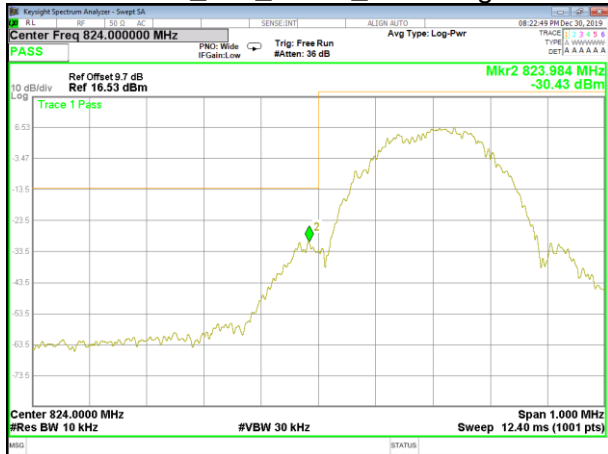

EGPRS\_850(8PSK)\_Lower\_Band edge

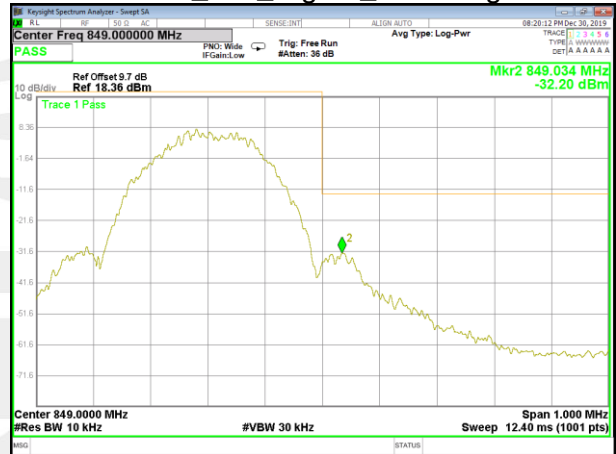

EGPRS\_850(8PSK)\_Higher\_Band edge

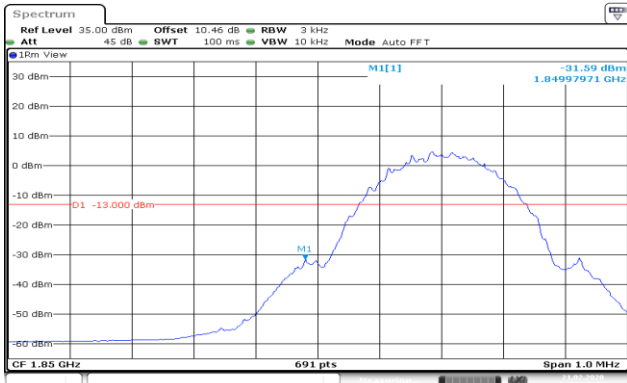

Date: 21.FEB.2020 14:26:36

GPRS\_1900\_Lower\_Band edge

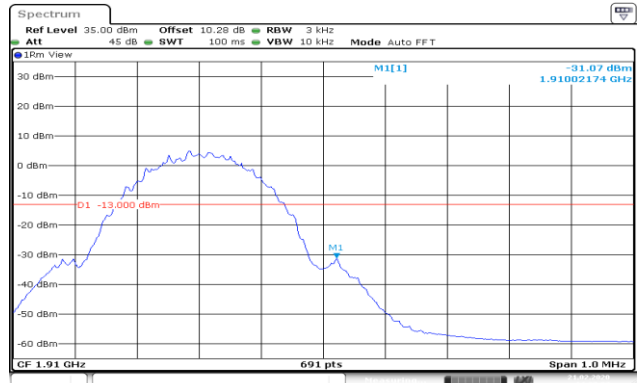

Date: 21.FEB.2020 14:27:07

GPRS\_1900\_Higher\_Band edge

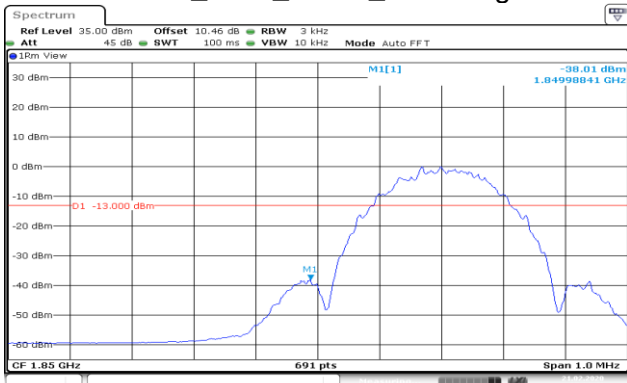

Date: 21.FEB.2020 15:11:42

EGPRS\_1900(8PSK)\_Lower\_Band edge

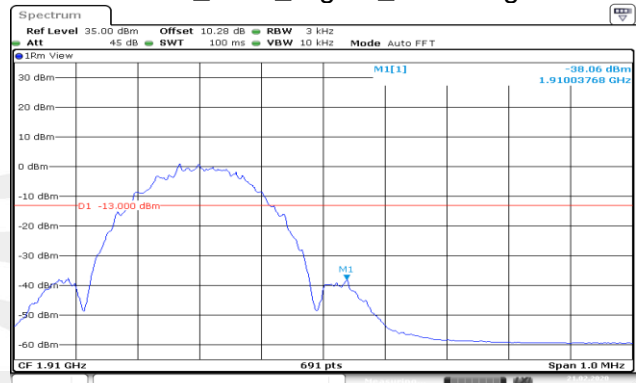

Date: 21.FEB.2020 15:12:13

EGPRS\_1900(8PSK)\_Higher\_Band edge



A7. FIELD STRENGTH OF SPURIOUS RADIATION MEASUREMENT

GPRS 850-GMSK-Low-H

RE\_FCC Test Case\_FCC Part 22&24&27 30MHz-13GHz-H

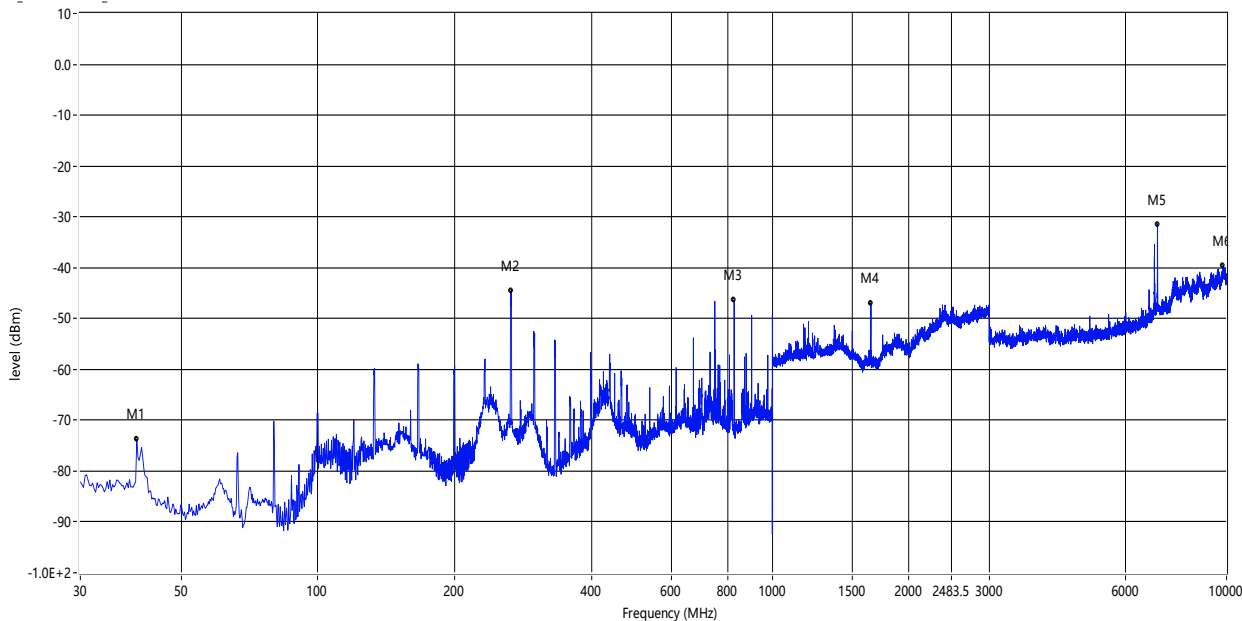

Frequency (MHz)	Result (dBm)	Limit (dBm)	Over Limit (dB)	ANT	Verdict
39.943	-73.83	-13.0	-60.83	Horizontal	Pass
266.438	-44.64	-13.0	-31.64	Horizontal	Pass
824.188	-46.44	-13.0	-33.44	Horizontal	Pass
1648.500	-47.00	-13.0	-34.00	Horizontal	Pass
7044.250	-31.52	-13.0	-18.52	Horizontal	Pass
9818.000	-39.70	-13.0	-26.70	Horizontal	Pass



GPRS 850-GMSK-Low-V

RE\_FCC Test Case\_FCC Part 22&24&27 30MHz-13GHz-V

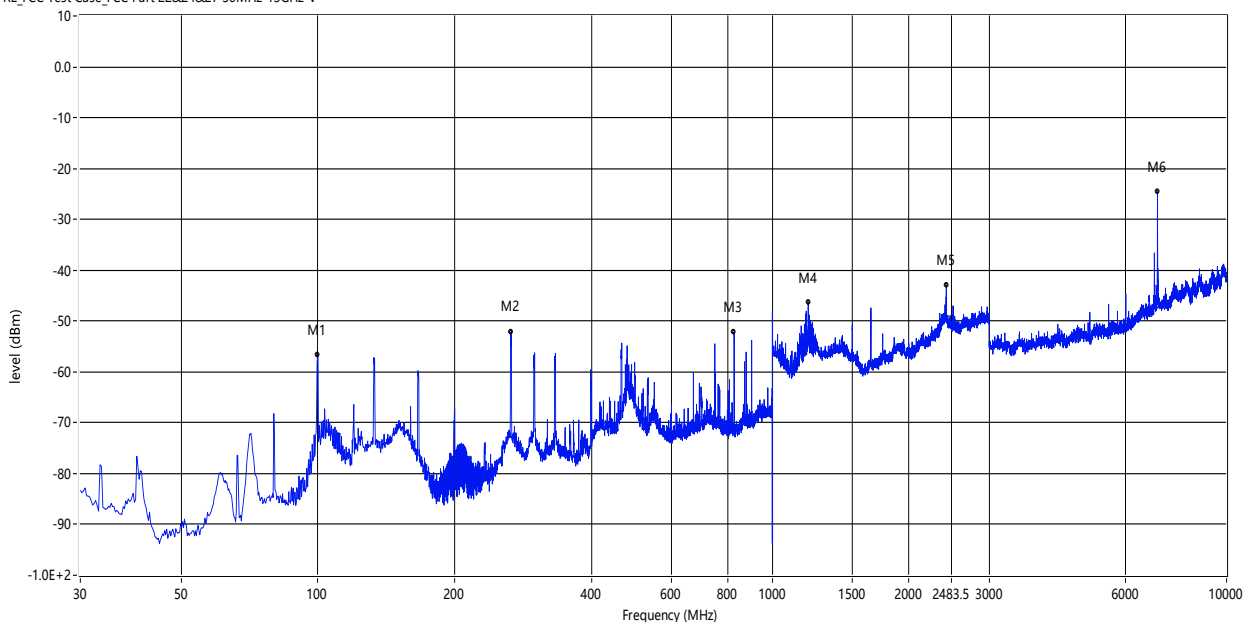

Frequency (MHz)	Result (dBm)	Limit (dBm)	Over Limit (dB)	ANT	Verdict
99.840	-56.74	-13.0	-43.74	Vertical	Pass
266.438	-52.07	-13.0	-39.07	Vertical	Pass
824.188	-52.16	-13.0	-39.16	Vertical	Pass
1200.000	-46.40	-13.0	-33.40	Vertical	Pass
2415.500	-43.07	-13.0	-30.07	Vertical	Pass
7046.000	-24.59	-13.0	-11.59	Vertical	Pass



GPRS 850-GMSK-Mid-H

RE\_FCC Test Case\_FCC Part 22&24&27 30MHz-13GHz-H

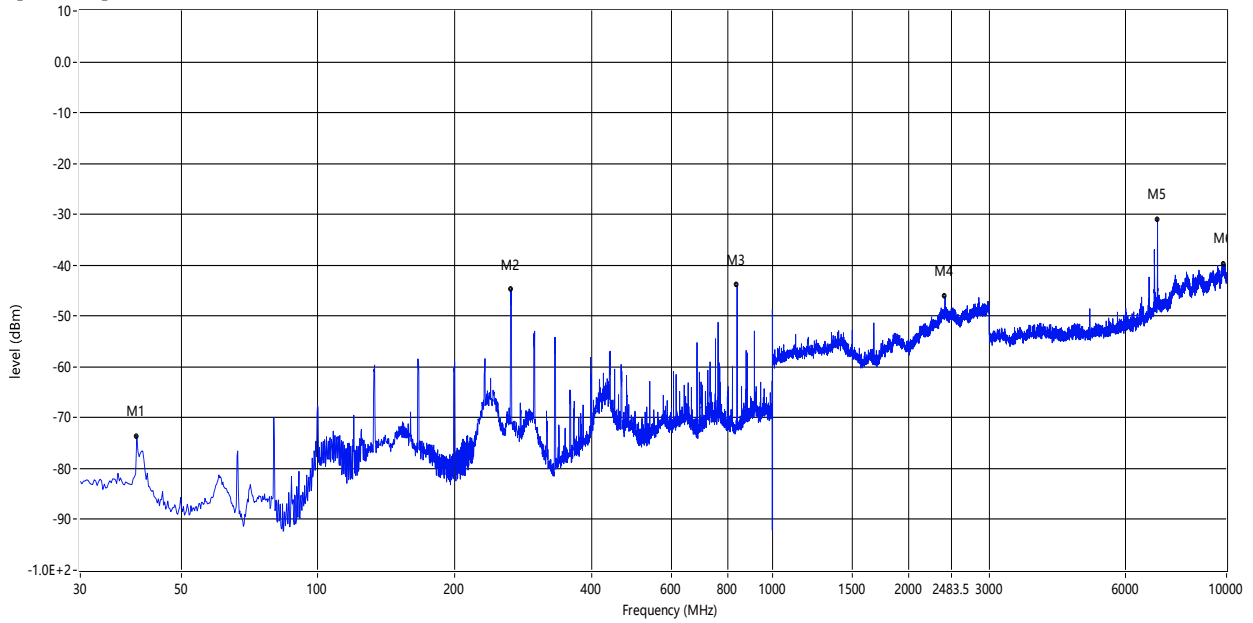

Frequency (MHz)	Result (dBm)	Limit (dBm)	Over Limit (dB)	ANT	Verdict
39.943	-73.68	-13.0	-60.68	Horizontal	Pass
266.680	-44.74	-13.0	-31.74	Horizontal	Pass
836.555	-43.89	-13.0	-30.89	Horizontal	Pass
2400.500	-46.20	-13.0	-33.20	Horizontal	Pass
7047.750	-30.97	-13.0	-17.97	Horizontal	Pass
9868.750	-39.76	-13.0	-26.76	Horizontal	Pass



GPRS 850-GMSK-Mid-V

RE\_FCC Test Case\_FCC Part 22&24&27 30MHz-13GHz-V

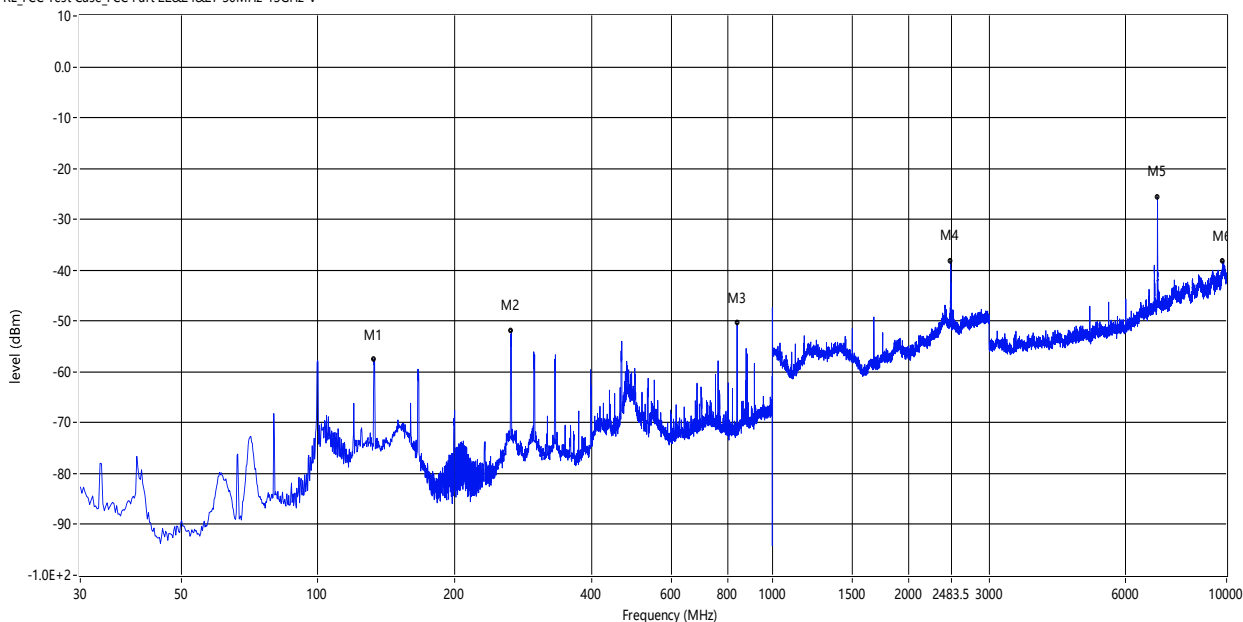

Frequency (MHz)	Result (dBm)	Limit (dBm)	Over Limit (dB)	ANT	Verdict
132.820	-57.52	-13.0	-44.52	Vertical	Pass
266.438	-51.88	-13.0	-38.88	Vertical	Pass
836.798	-50.47	-13.0	-37.47	Vertical	Pass
2469.000	-38.31	-13.0	-25.31	Vertical	Pass
7044.250	-25.65	-13.0	-12.65	Vertical	Pass
9819.750	-38.24	-13.0	-25.24	Vertical	Pass





GPRS 850-GMSK-High-H

RE\_FCC Test Case\_FCC Part 22&24&27 30MHz-13GHz-H

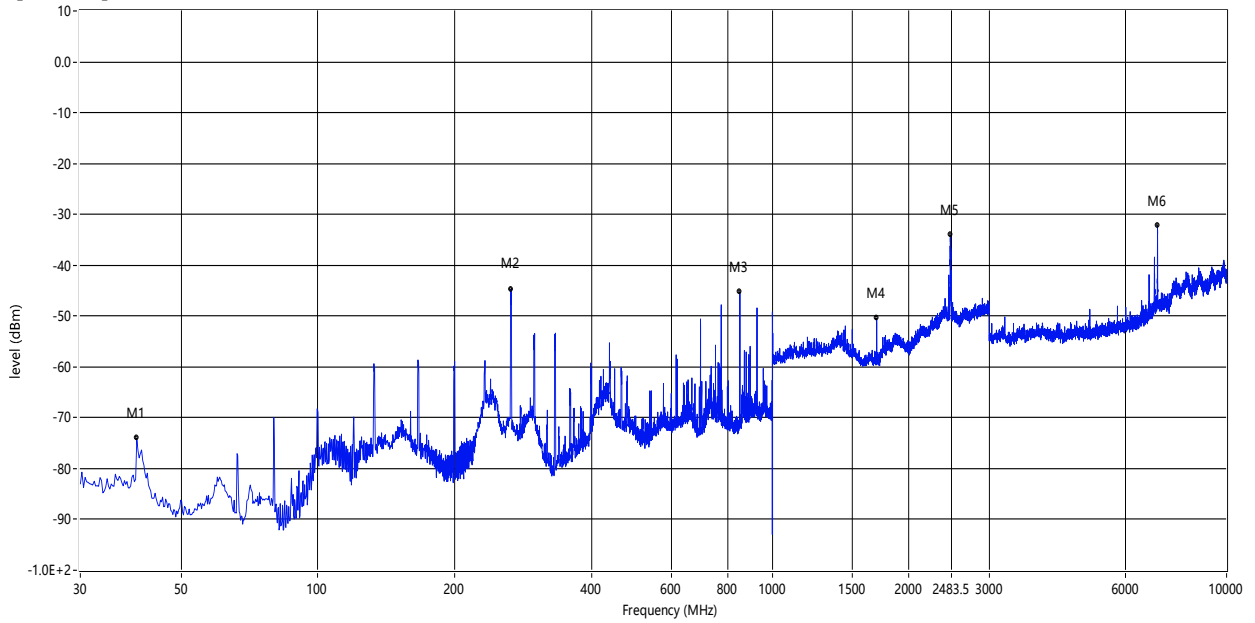

Frequency (MHz)	Result (dBm)	Limit (dBm)	Over Limit (dB)	ANT	Verdict
39.943	-74.04	-13.0	-61.04	Horizontal	Pass
265.710	-44.80	-13.0	-31.80	Horizontal	Pass
848.680	-45.23	-13.0	-32.23	Horizontal	Pass
1698.000	-50.48	-13.0	-37.48	Horizontal	Pass
2465.500	-34.06	-13.0	-21.06	Horizontal	Pass
7046.000	-32.19	-13.0	-19.19	Horizontal	Pass



GPRS 850-GMSK-High-V

RE\_FCC Test Case\_FCC Part 22&24&27 30MHz-13GHz-V

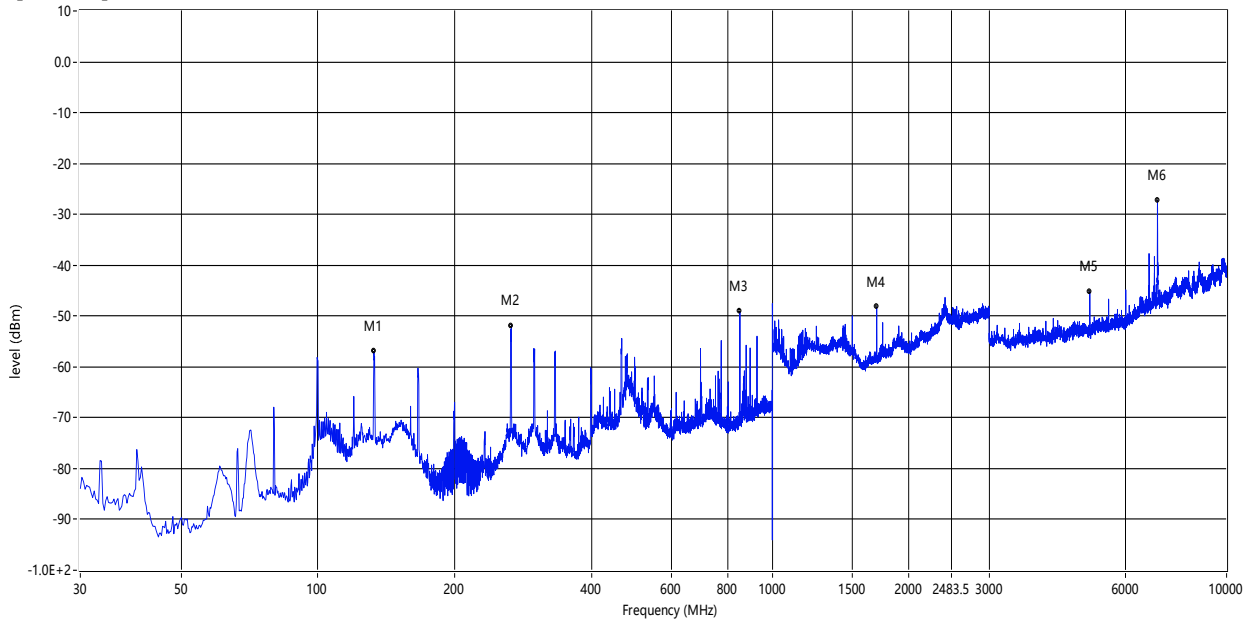

Frequency (MHz)	Result (dBm)	Limit (dBm)	Over Limit (dB)	ANT	Verdict
132.820	-57.01	-13.0	-44.01	Vertical	Pass
266.438	-51.89	-13.0	-38.89	Vertical	Pass
848.922	-49.06	-13.0	-36.06	Vertical	Pass
1698.000	-48.20	-13.0	-35.20	Vertical	Pass
5000.250	-45.17	-13.0	-32.17	Vertical	Pass
7044.250	-27.29	-13.0	-14.29	Vertical	Pass



EGPRS 850-8PSK-Low-H

RE\_FCC Test Case\_FCC Part 22&24&27 30MHz-13GHz-H

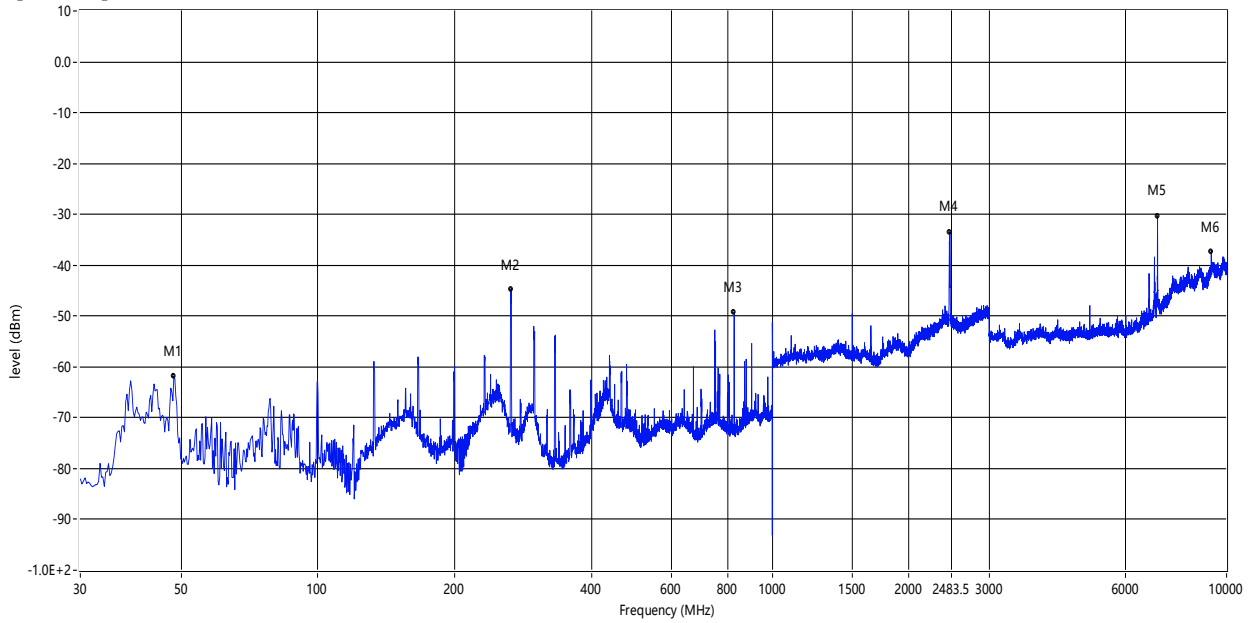

Frequency (MHz)	Result (dBm)	Limit (dBm)	Over Limit (dB)	ANT	Verdict
48.187	-61.83	-13.0	-48.83	Horizontal	Pass
265.468	-44.75	-13.0	-31.75	Horizontal	Pass
824.430	-49.28	-13.0	-36.28	Horizontal	Pass
2459.500	-33.48	-13.0	-20.48	Horizontal	Pass
7047.750	-30.33	-13.0	-17.33	Horizontal	Pass
9251.000	-37.42	-13.0	-24.42	Horizontal	Pass



EGPRS 850-8PSK-Low-V

RE\_FCC Test Case\_FCC Part 22&24&27 30MHz-13GHz-V

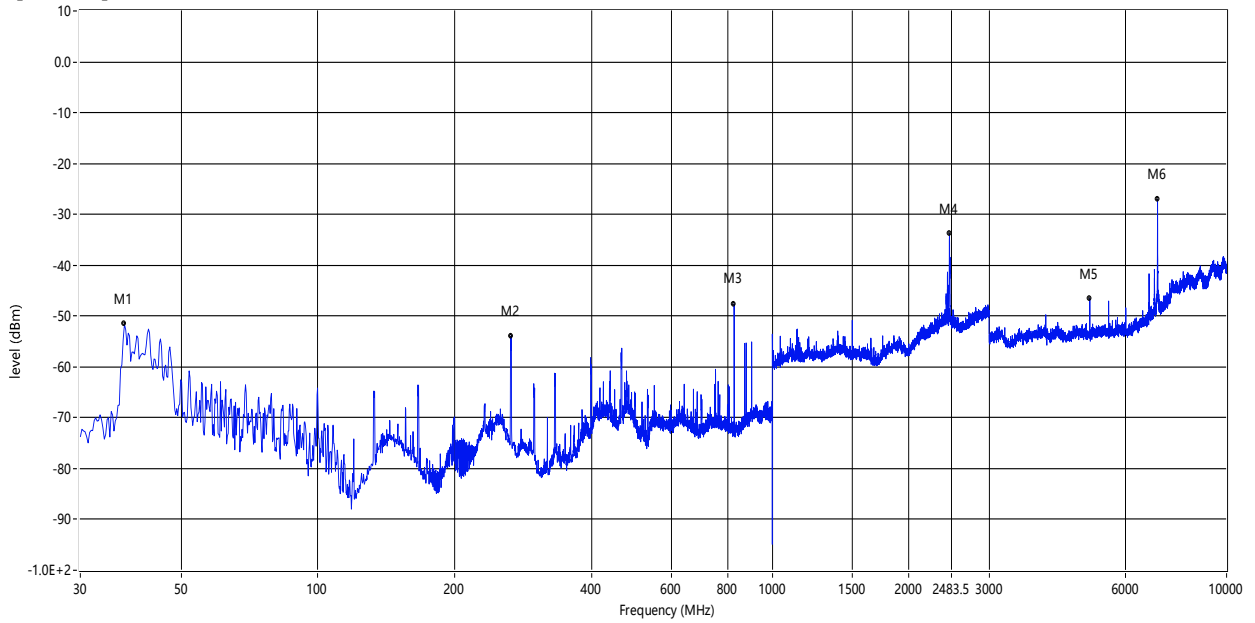

Frequency (MHz)	Result (dBm)	Limit (dBm)	Over Limit (dB)	ANT	Verdict
37.517	-51.61	-13.0	-38.61	Vertical	Pass
265.468	-53.96	-13.0	-40.96	Vertical	Pass
824.188	-47.61	-13.0	-34.61	Vertical	Pass
2455.500	-33.79	-13.0	-20.79	Vertical	Pass
5000.250	-46.54	-13.0	-33.54	Vertical	Pass
7047.750	-27.03	-13.0	-14.03	Vertical	Pass



EGPRS 850-8PSK-Mid-H

RE\_FCC Test Case\_FCC Part 22&24&27 30MHz-13GHz-H

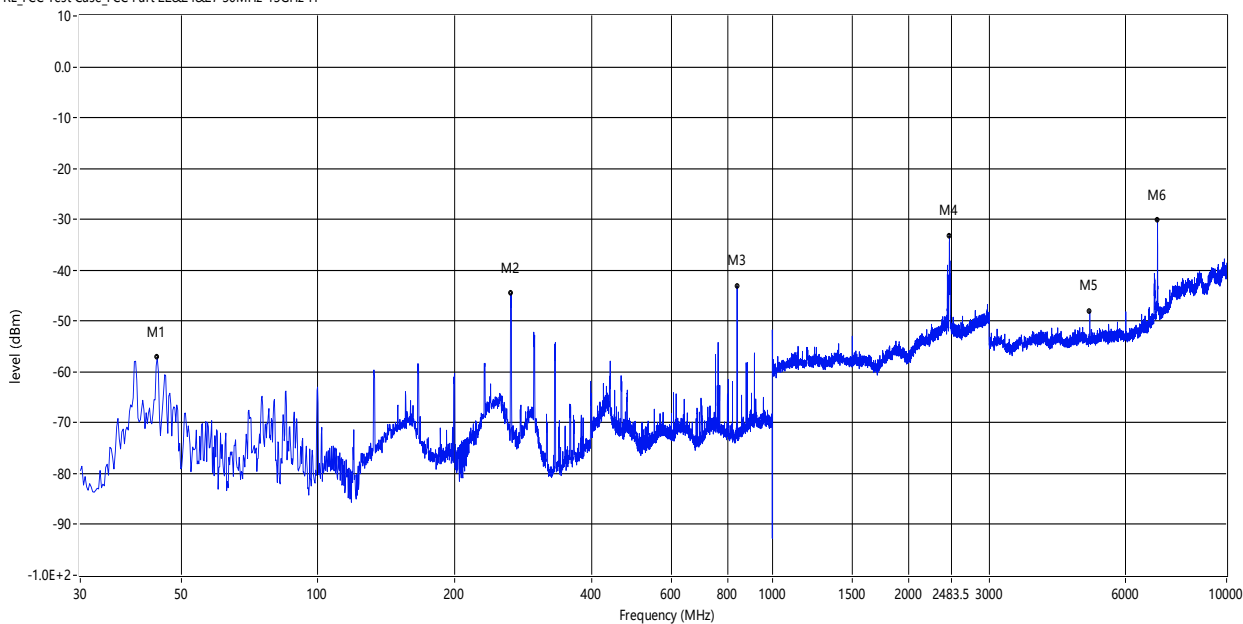

Frequency (MHz)	Result (dBm)	Limit (dBm)	Over Limit (dB)	ANT	Verdict
44.307	-57.14	-13.0	-44.14	Horizontal	Pass
266.438	-44.55	-13.0	-31.55	Horizontal	Pass
836.798	-43.15	-13.0	-30.15	Horizontal	Pass
2455.000	-33.22	-13.0	-20.22	Horizontal	Pass
5000.250	-48.05	-13.0	-35.05	Horizontal	Pass
7047.750	-30.14	-13.0	-17.14	Horizontal	Pass



EGPRS 850-8PSK-Mid-V

RE\_FCC Test Case\_FCC Part 22&24&27 30MHz-13GHz-V

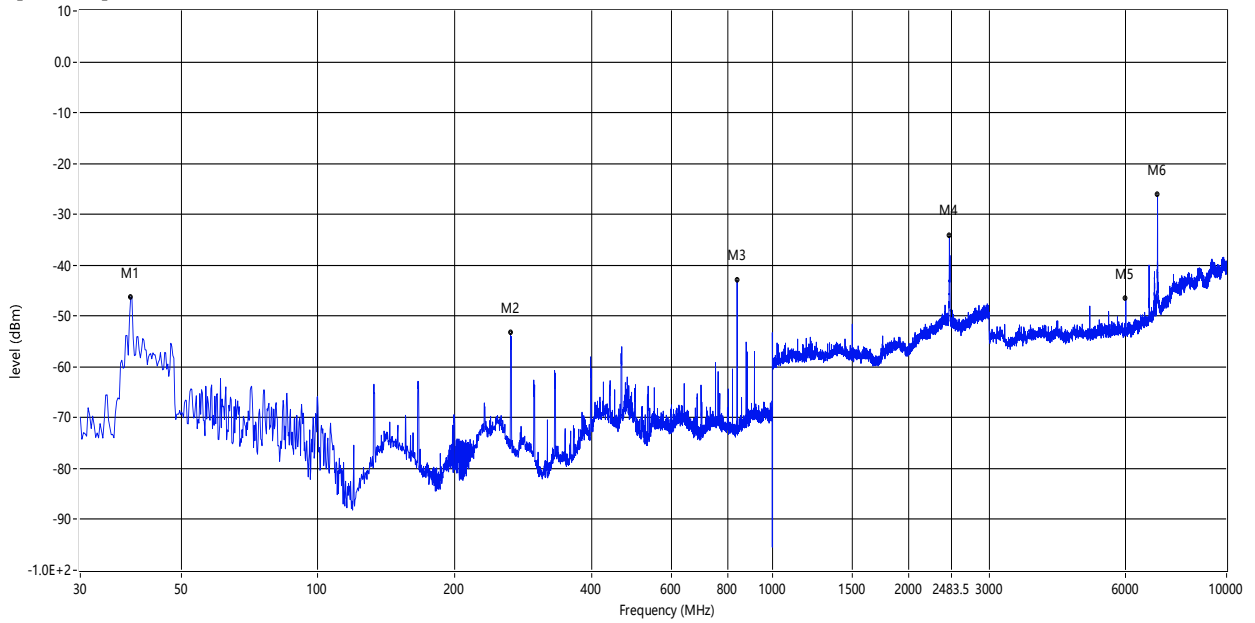

Frequency (MHz)	Result (dBm)	Limit (dBm)	Over Limit (dB)	ANT	Verdict
38.730	-46.30	-13.0	-33.30	Vertical	Pass
265.468	-53.39	-13.0	-40.39	Vertical	Pass
836.798	-43.04	-13.0	-30.04	Vertical	Pass
2454.000	-34.26	-13.0	-21.26	Vertical	Pass
5999.500	-46.67	-13.0	-33.67	Vertical	Pass
7047.750	-26.22	-13.0	-13.22	Vertical	Pass



EGPRS 850-8PSK-High-H

RE\_FCC Test Case\_FCC Part 22&24&27 30MHz-13GHz-H

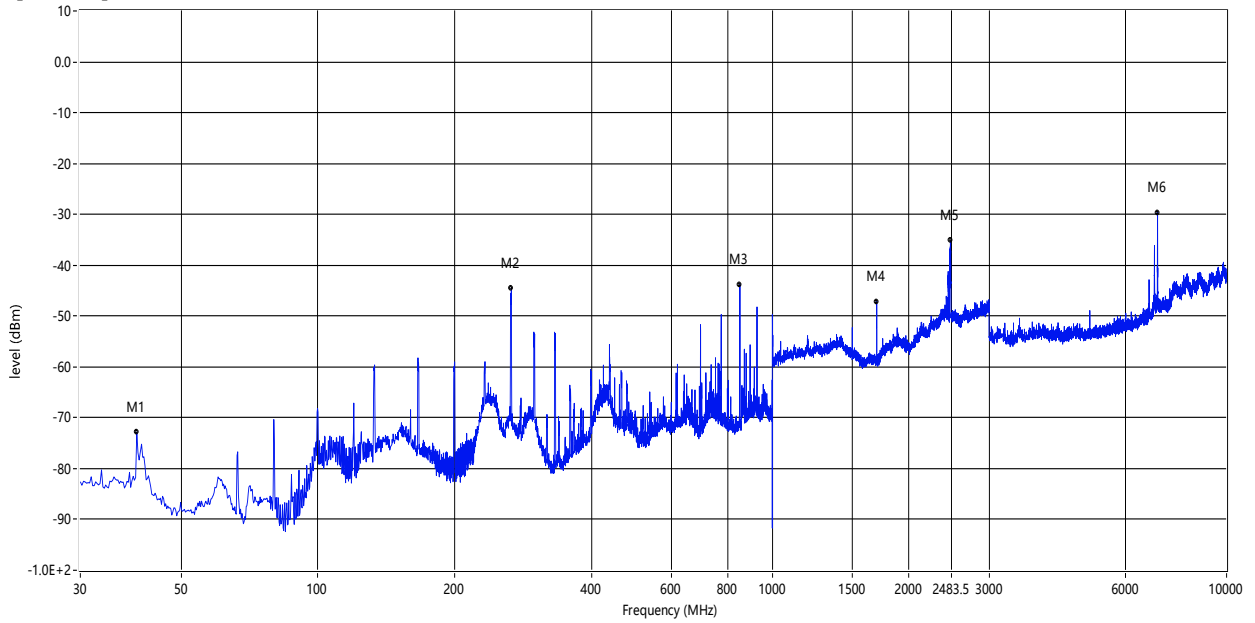

Frequency (MHz)	Result (dBm)	Limit (dBm)	Over Limit (dB)	ANT	Verdict
39.943	-72.81	-13.0	-59.81	Horizontal	Pass
266.438	-44.51	-13.0	-31.51	Horizontal	Pass
848.680	-43.77	-13.0	-30.77	Horizontal	Pass
1698.000	-47.14	-13.0	-34.14	Horizontal	Pass
2467.000	-35.18	-13.0	-22.18	Horizontal	Pass
7049.500	-29.65	-13.0	-16.65	Horizontal	Pass



EGPRS 850-8PSK-High-V

RE\_FCC Test Case\_FCC Part 22&24&27 30MHz-13GHz-V

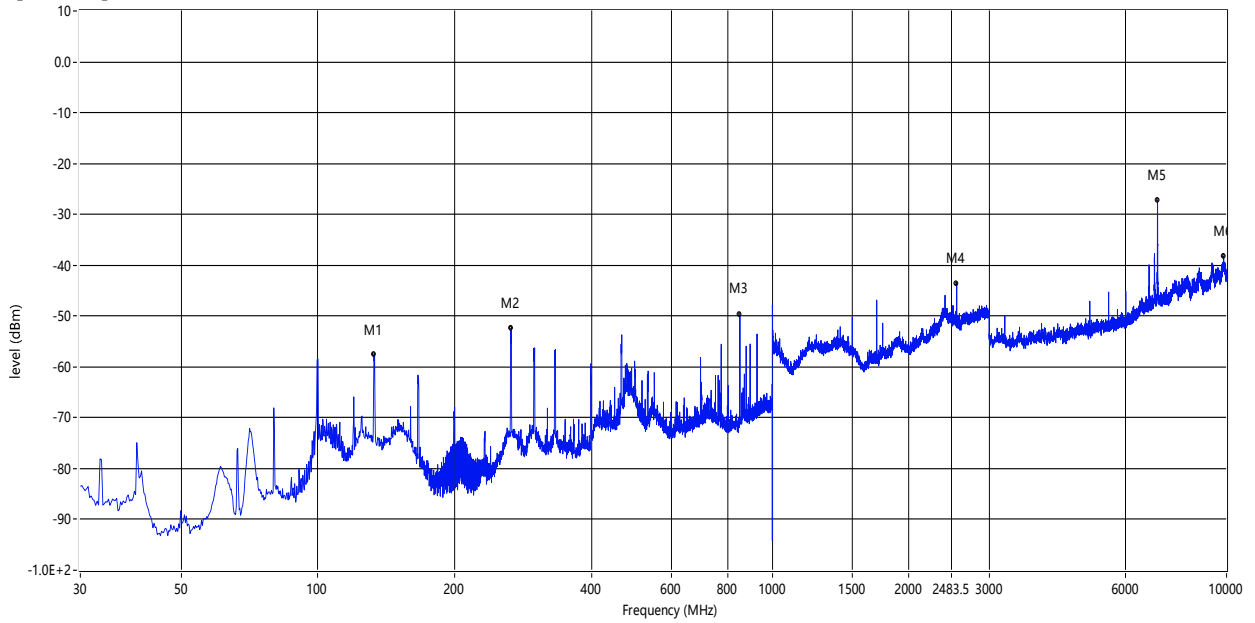

Frequency (MHz)	Result (dBm)	Limit (dBm)	Over Limit (dB)	ANT	Verdict
132.820	-57.61	-13.0	-44.61	Vertical	Pass
266.438	-52.51	-13.0	-39.51	Vertical	Pass
848.680	-49.82	-13.0	-36.82	Vertical	Pass
2547.000	-43.58	-13.0	-30.58	Vertical	Pass
7046.000	-27.36	-13.0	-14.36	Vertical	Pass
9853.000	-38.36	-13.0	-25.36	Vertical	Pass





GPRS 1900-GMSK-Low-H

RE\_FCC Test Case\_FCC Part 22&24&27 30MHz-13GHz-H

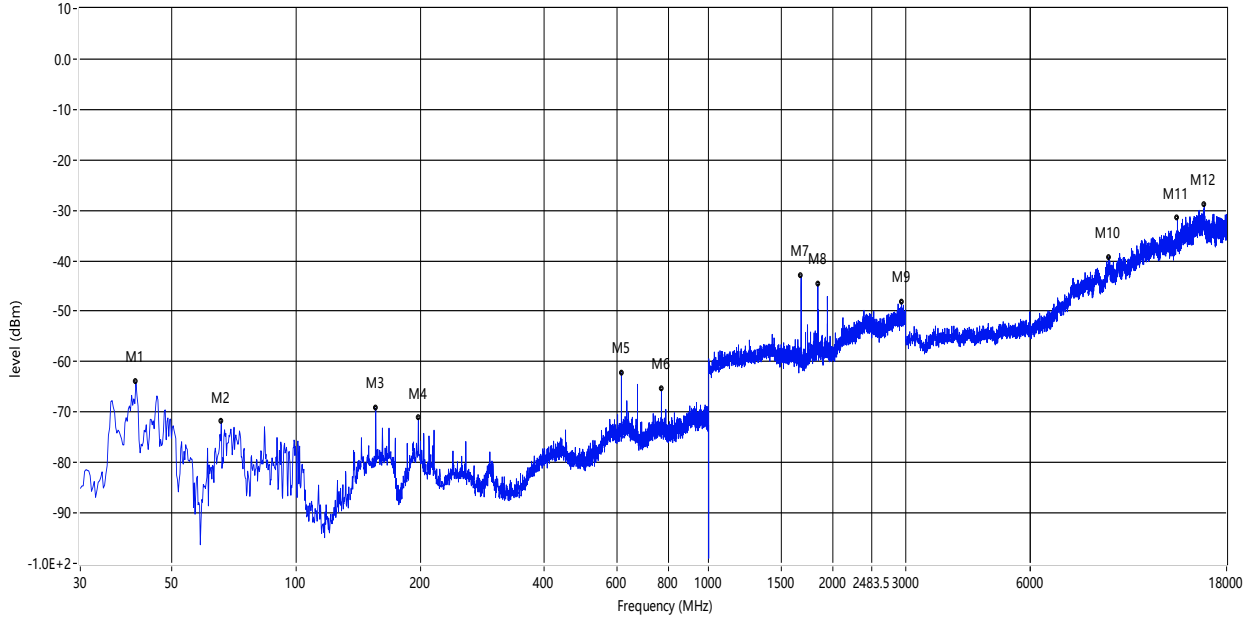

Frequency (MHz)	Result (dBm)	Limit (dBm)	Over Limit (dB)	ANT	Verdict
40.913	-64.02	-13.0	-51.02	Horizontal	Pass
65.890	-71.96	-13.0	-58.96	Horizontal	Pass
155.858	-69.16	-13.0	-56.16	Horizontal	Pass
198.053	-71.24	-13.0	-58.24	Horizontal	Pass
614.425	-62.20	-13.0	-49.20	Horizontal	Pass
768.170	-65.47	-13.0	-52.47	Horizontal	Pass
1675.000	-42.96	-13.0	-29.96	Horizontal	Pass
1839.000	-44.59	-13.0	-31.59	Horizontal	Pass
2932.500	-48.31	-13.0	-35.31	Horizontal	Pass
9327.500	-39.35	-13.0	-26.35	Horizontal	Pass
13680.000	-31.63	-13.0	-18.63	Horizontal	Pass
15885.000	-28.92	-13.0	-15.92	Horizontal	Pass



GPRS 1900-GMSK-Low-V

RE\_FCC Test Case\_FCC Part 22&24&27 30MHz-13GHz-V

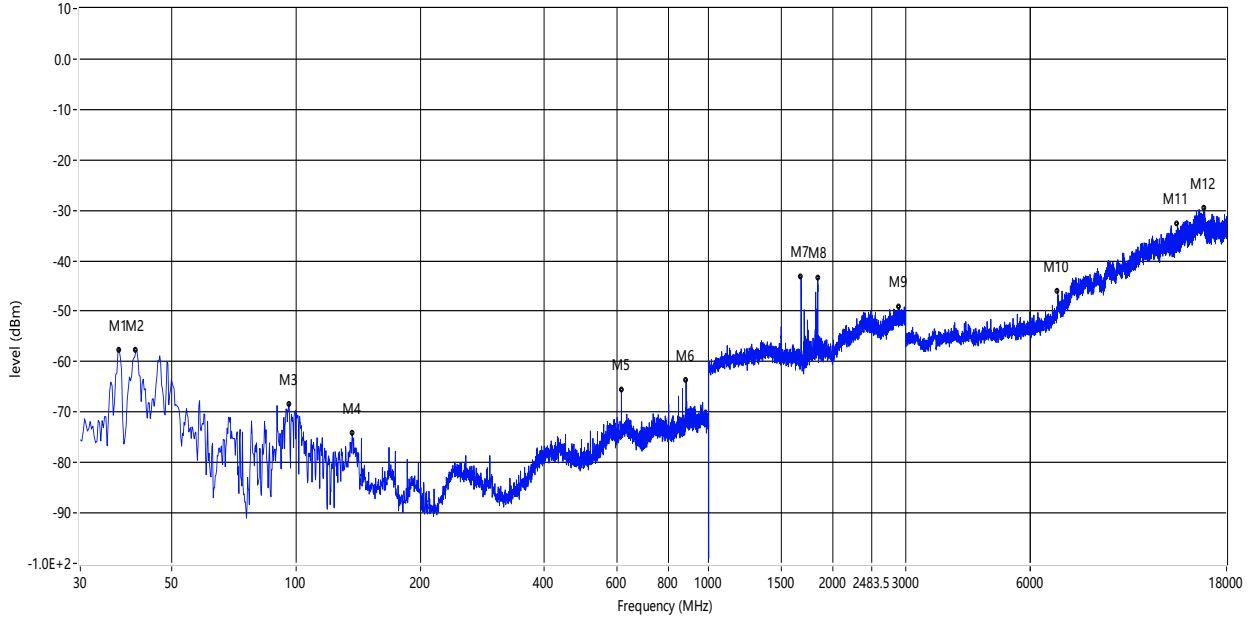

Frequency (MHz)	Result (dBm)	Limit (dBm)	Over Limit (dB)	ANT	Verdict
37.275	-57.66	-13.0	-44.66	Vertical	Pass
40.913	-57.79	-13.0	-44.79	Vertical	Pass
96.202	-68.42	-13.0	-55.42	Vertical	Pass
136.943	-74.27	-13.0	-61.27	Vertical	Pass
614.425	-65.66	-13.0	-52.66	Vertical	Pass
881.417	-63.79	-13.0	-50.79	Vertical	Pass
1674.500	-43.12	-13.0	-30.12	Vertical	Pass
1838.500	-43.40	-13.0	-30.40	Vertical	Pass
2896.500	-49.25	-13.0	-36.25	Vertical	Pass
7012.500	-46.04	-13.0	-33.04	Vertical	Pass
13682.500	-32.61	-13.0	-19.61	Vertical	Pass
15867.500	-29.71	-13.0	-16.71	Vertical	Pass



GPRS 1900-GMSK-Mid-H

RE\_FCC Test Case\_FCC Part 22&24&27 30MHz-13GHz-H

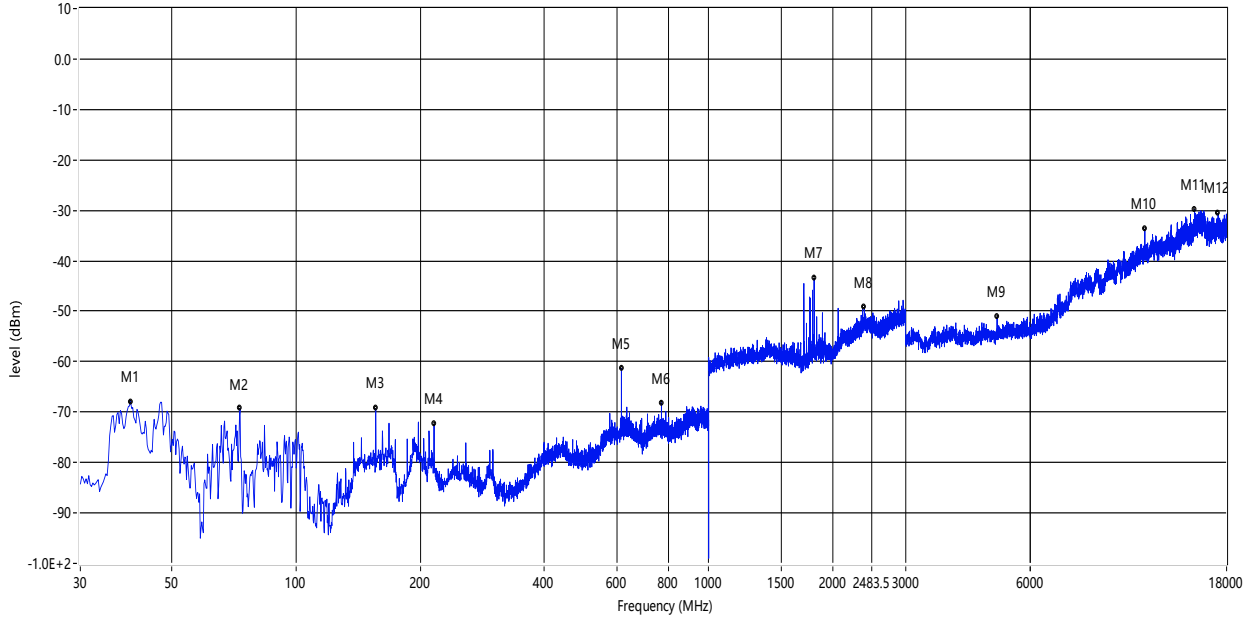

Frequency (MHz)	Result (dBm)	Limit (dBm)	Over Limit (dB)	ANT	Verdict
39.700	-67.91	-13.0	-54.91	Horizontal	Pass
73.165	-69.29	-13.0	-56.29	Horizontal	Pass
155.858	-69.34	-13.0	-56.34	Horizontal	Pass
215.998	-72.40	-13.0	-59.40	Horizontal	Pass
614.425	-61.35	-13.0	-48.35	Horizontal	Pass
768.170	-68.16	-13.0	-55.16	Horizontal	Pass
1801.000	-43.54	-13.0	-30.54	Horizontal	Pass
2382.000	-49.29	-13.0	-36.29	Horizontal	Pass
5000.000	-51.13	-13.0	-38.13	Horizontal	Pass
11405.000	-33.75	-13.0	-20.75	Horizontal	Pass
15058.750	-29.88	-13.0	-16.88	Horizontal	Pass
17163.750	-30.67	-13.0	-17.67	Horizontal	Pass



GPRS 1900-GMSK-Mid-V

RE\_FCC Test Case\_FCC Part 22&24&27 30MHz-13GHz-V

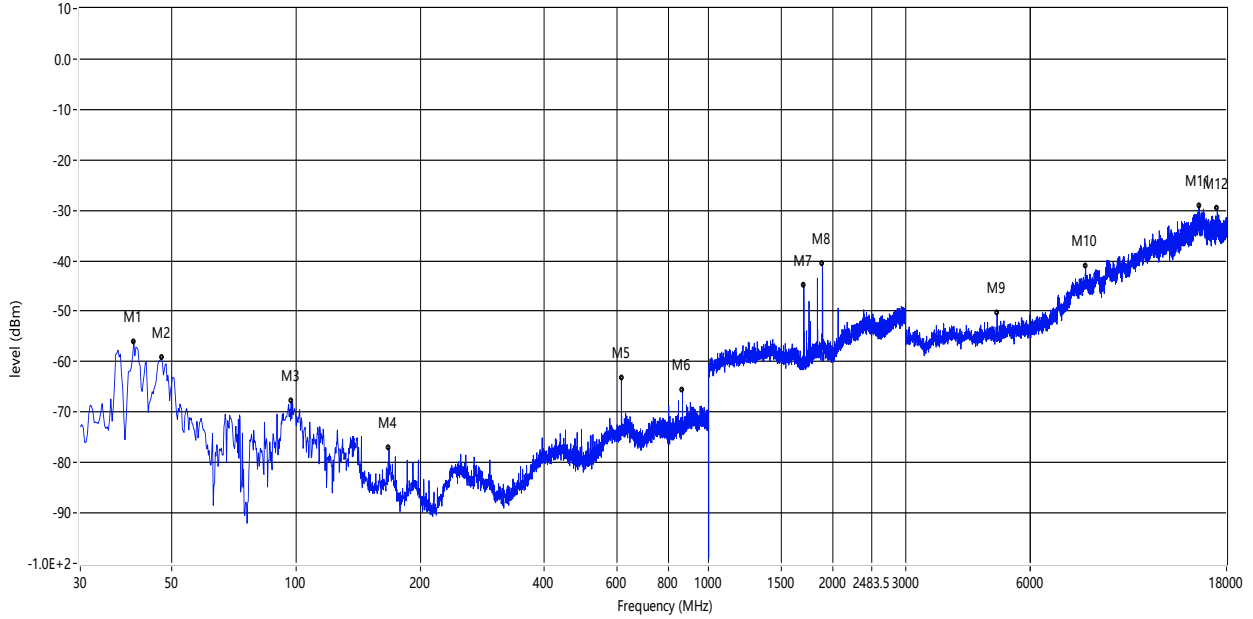

Frequency (MHz)	Result (dBm)	Limit (dBm)	Over Limit (dB)	ANT	Verdict
40.428	-55.98	-13.0	-42.98	Vertical	Pass
47.218	-59.29	-13.0	-46.29	Vertical	Pass
97.415	-67.83	-13.0	-54.83	Vertical	Pass
167.982	-77.07	-13.0	-64.07	Vertical	Pass
614.425	-63.26	-13.0	-50.26	Vertical	Pass
864.200	-65.52	-13.0	-52.52	Vertical	Pass
1701.000	-44.78	-13.0	-31.78	Vertical	Pass
1886.000	-40.68	-13.0	-27.68	Vertical	Pass
5000.000	-50.45	-13.0	-37.45	Vertical	Pass
8197.500	-41.03	-13.0	-28.03	Vertical	Pass
15436.250	-29.10	-13.0	-16.10	Vertical	Pass
17087.500	-29.66	-13.0	-16.66	Vertical	Pass



GPRS 1900-GMSK-High-H

RE\_FCC Test Case\_FCC Part 22&24&27 30MHz-13GHz-H

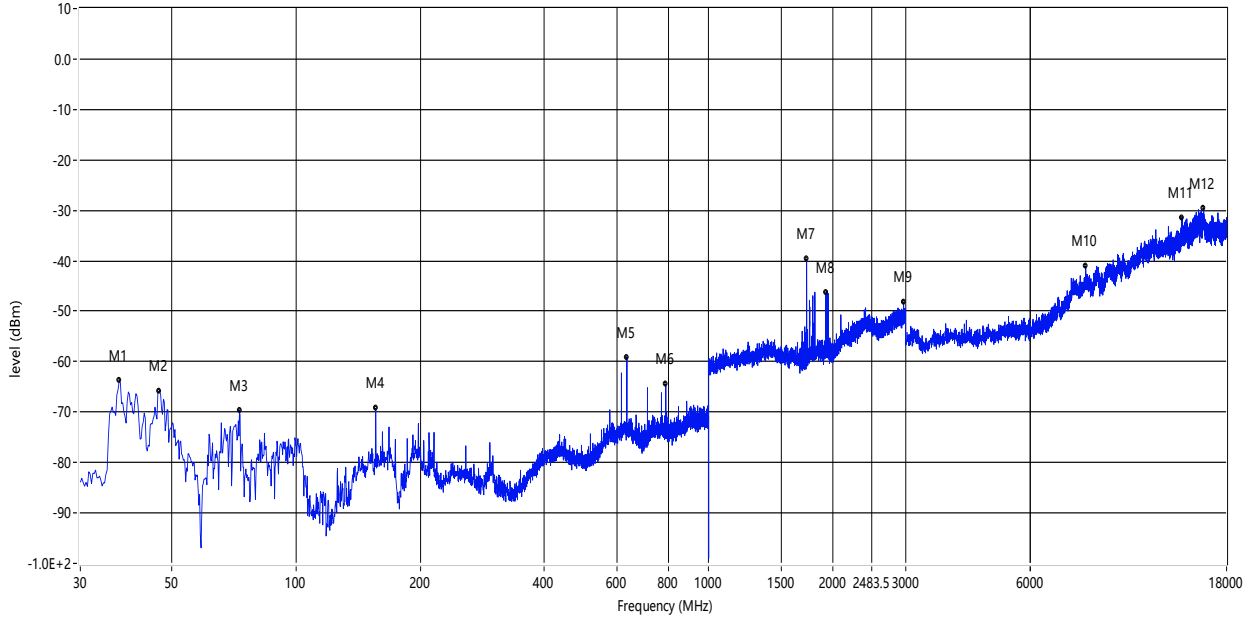

Frequency (MHz)	Result (dBm)	Limit (dBm)	Over Limit (dB)	ANT	Verdict
37.275	-63.79	-13.0	-50.79	Horizontal	Pass
46.490	-65.89	-13.0	-52.89	Horizontal	Pass
72.923	-69.70	-13.0	-56.70	Horizontal	Pass
155.858	-69.27	-13.0	-56.27	Horizontal	Pass
633.583	-59.11	-13.0	-46.11	Horizontal	Pass
787.327	-64.44	-13.0	-51.44	Horizontal	Pass
1728.000	-39.74	-13.0	-26.74	Horizontal	Pass
1924.000	-46.30	-13.0	-33.30	Horizontal	Pass
2968.000	-48.19	-13.0	-35.19	Horizontal	Pass
8202.500	-41.03	-13.0	-28.03	Horizontal	Pass
14025.000	-31.43	-13.0	-18.43	Horizontal	Pass
15833.750	-29.65	-13.0	-16.65	Horizontal	Pass



GPRS 1900-GMSK-High-V

RE\_FCC Test Case\_FCC Part 22&24&27 30MHz-13GHz-V

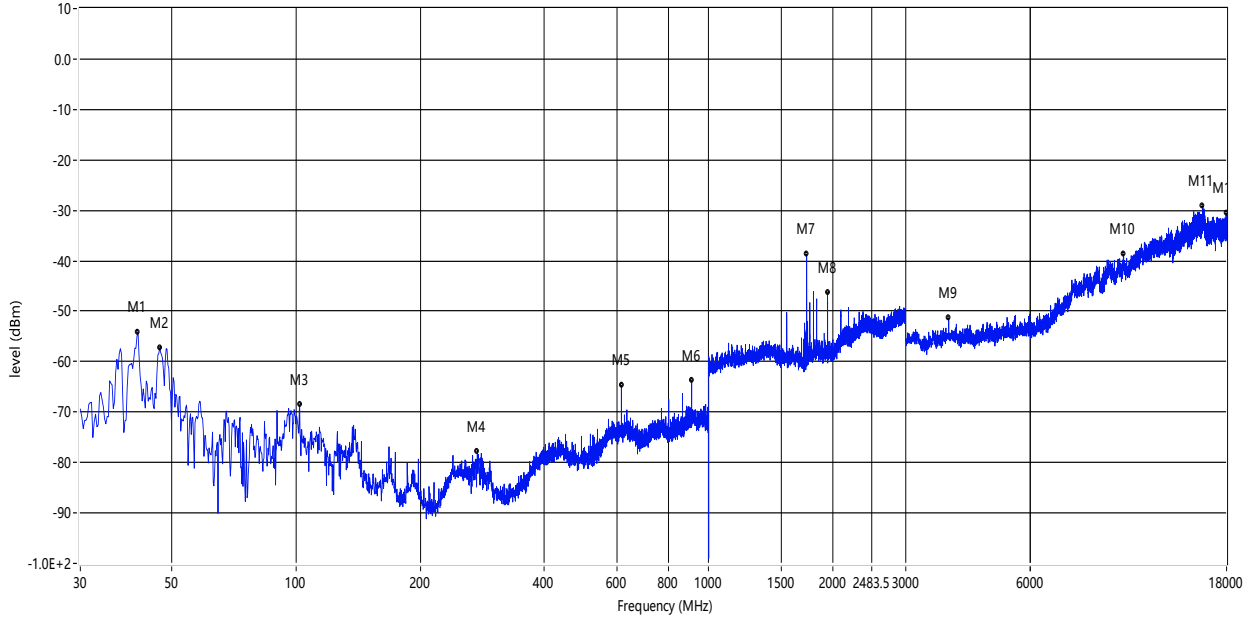

Frequency (MHz)	Result (dBm)	Limit (dBm)	Over Limit (dB)	ANT	Verdict
41.398	-54.22	-13.0	-41.22	Vertical	Pass
46.733	-57.22	-13.0	-44.22	Vertical	Pass
102.022	-68.59	-13.0	-55.59	Vertical	Pass
274.925	-77.86	-13.0	-64.86	Vertical	Pass
614.425	-64.72	-13.0	-51.72	Vertical	Pass
909.305	-63.76	-13.0	-50.76	Vertical	Pass
1727.500	-38.78	-13.0	-25.78	Vertical	Pass
1941.000	-46.32	-13.0	-33.32	Vertical	Pass
3817.500	-51.41	-13.0	-38.41	Vertical	Pass
10127.500	-38.71	-13.0	-25.71	Vertical	Pass
15758.750	-29.18	-13.0	-16.18	Vertical	Pass
17963.749	-30.58	-13.0	-17.58	Vertical	Pass



EGPRS 1900-8PSK-Low-H

RE\_FCC Test Case\_FCC Part 22&24&27 30MHz-13GHz-H

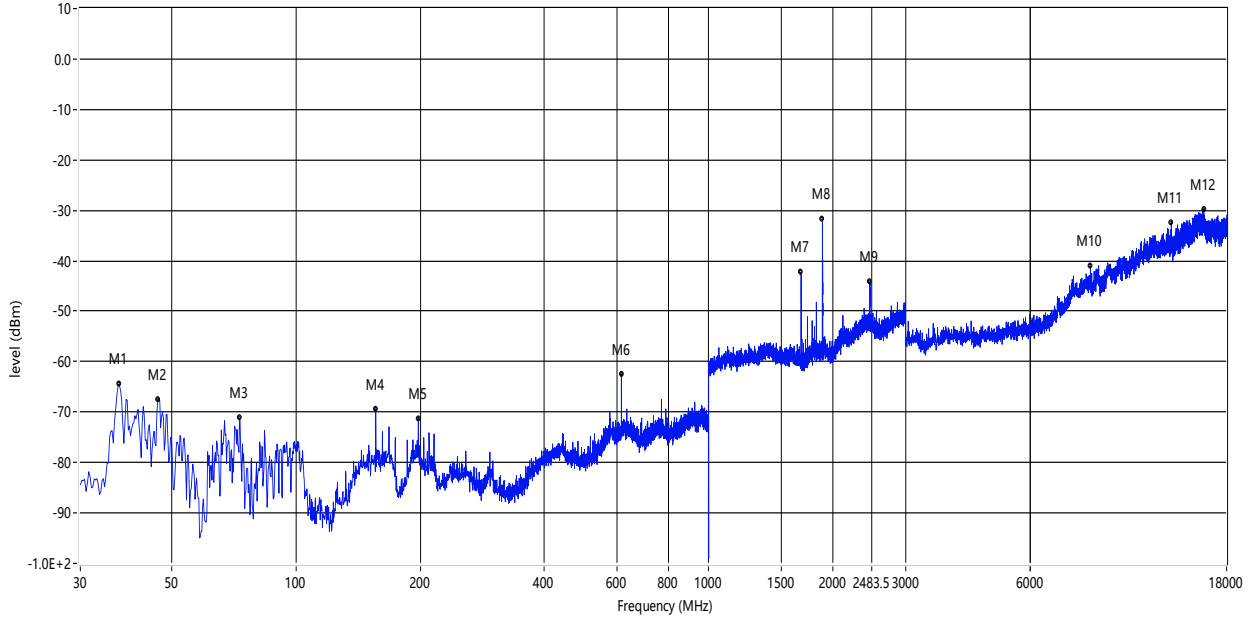

Frequency (MHz)	Result (dBm)	Limit (dBm)	Over Limit (dB)	ANT	Verdict
37.275	-64.54	-13.0	-51.54	Horizontal	Pass
46.248	-67.46	-13.0	-54.46	Horizontal	Pass
72.923	-71.20	-13.0	-58.20	Horizontal	Pass
155.858	-69.36	-13.0	-56.36	Horizontal	Pass
197.810	-71.25	-13.0	-58.25	Horizontal	Pass
614.425	-62.49	-13.0	-49.49	Horizontal	Pass
1674.500	-42.35	-13.0	-29.35	Horizontal	Pass
1886.500	-31.80	-13.0	-18.80	Horizontal	Pass
2456.500	-44.17	-13.0	-31.17	Horizontal	Pass
8422.500	-41.09	-13.0	-28.09	Horizontal	Pass
13217.500	-32.48	-13.0	-19.48	Horizontal	Pass
15847.500	-29.80	-13.0	-16.80	Horizontal	Pass



EGPRS 1900-8PSK-Low-V

RE\_FCC Test Case\_FCC Part 22&24&27 30MHz-13GHz-V

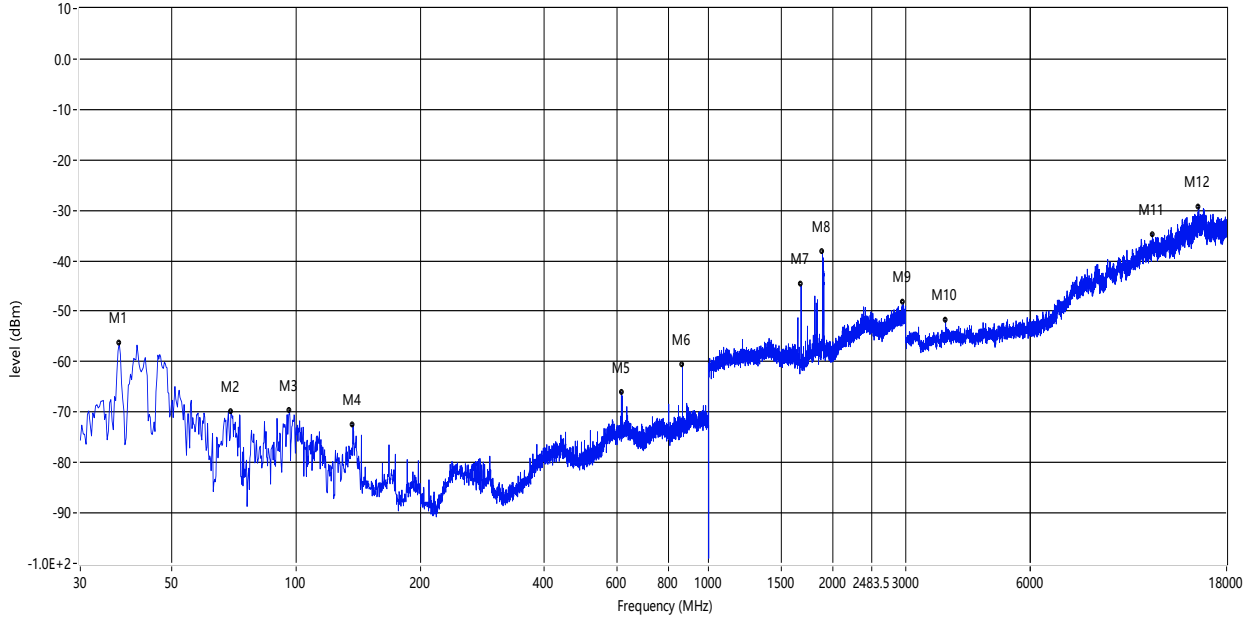

Frequency (MHz)	Result (dBm)	Limit (dBm)	Over Limit (dB)	ANT	Verdict
37.275	-56.33	-13.0	-43.33	Vertical	Pass
69.527	-69.90	-13.0	-56.90	Vertical	Pass
96.445	-69.69	-13.0	-56.69	Vertical	Pass
137.428	-72.47	-13.0	-59.47	Vertical	Pass
614.425	-66.03	-13.0	-53.03	Vertical	Pass
864.200	-60.56	-13.0	-47.56	Vertical	Pass
1674.000	-44.73	-13.0	-31.73	Vertical	Pass
1888.000	-38.23	-13.0	-25.23	Vertical	Pass
2961.000	-48.24	-13.0	-35.24	Vertical	Pass
3752.500	-51.73	-13.0	-38.73	Vertical	Pass
11897.500	-34.78	-13.0	-21.78	Vertical	Pass
15412.500	-29.29	-13.0	-16.29	Vertical	Pass





EGPRS 1900-8PSK-Mid-H

RE\_FCC Test Case\_FCC Part 22&24&27 30MHz-13GHz-H

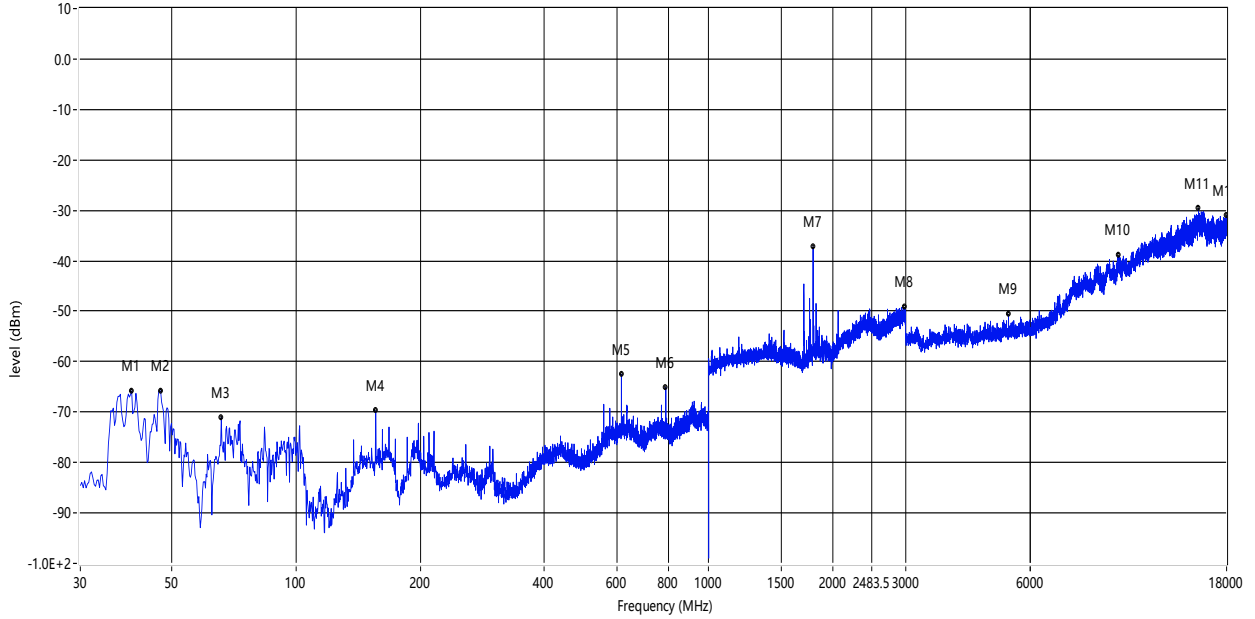

Frequency (MHz)	Result (dBm)	Limit (dBm)	Over Limit (dB)	ANT	Verdict
39.943	-65.80	-13.0	-52.80	Horizontal	Pass
46.975	-65.81	-13.0	-52.81	Horizontal	Pass
65.890	-71.07	-13.0	-58.07	Horizontal	Pass
155.858	-69.74	-13.0	-56.74	Horizontal	Pass
614.425	-62.55	-13.0	-49.55	Horizontal	Pass
787.327	-65.07	-13.0	-52.07	Horizontal	Pass
1791.000	-37.26	-13.0	-24.26	Horizontal	Pass
2980.500	-49.21	-13.0	-36.21	Horizontal	Pass
5330.000	-50.64	-13.0	-37.64	Horizontal	Pass
9862.500	-39.00	-13.0	-26.00	Horizontal	Pass
15392.500	-29.66	-13.0	-16.66	Horizontal	Pass
17984.999	-31.03	-13.0	-18.03	Horizontal	Pass



EGPRS 1900-8PSK-Mid-V

RE\_FCC Test Case\_FCC Part 22&24&27 30MHz-13GHz-V

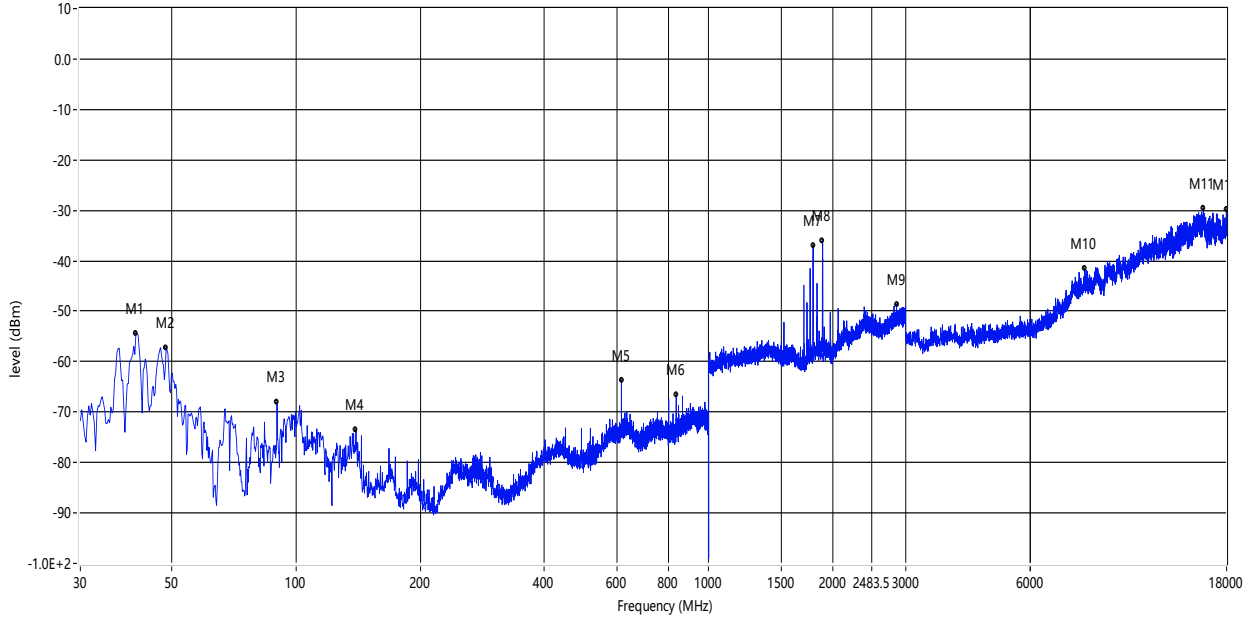

Frequency (MHz)	Result (dBm)	Limit (dBm)	Over Limit (dB)	ANT	Verdict
40.913	-54.31	-13.0	-41.31	Vertical	Pass
48.430	-57.18	-13.0	-44.18	Vertical	Pass
89.897	-68.01	-13.0	-55.01	Vertical	Pass
139.610	-73.49	-13.0	-60.49	Vertical	Pass
614.425	-63.67	-13.0	-50.67	Vertical	Pass
834.130	-66.65	-13.0	-53.65	Vertical	Pass
1791.000	-36.93	-13.0	-23.93	Vertical	Pass
1888.000	-36.08	-13.0	-23.08	Vertical	Pass
2853.000	-48.68	-13.0	-35.68	Vertical	Pass
8142.500	-41.61	-13.0	-28.61	Vertical	Pass
15797.500	-29.63	-13.0	-16.63	Vertical	Pass
17974.999	-29.92	-13.0	-16.92	Vertical	Pass



EGPRS 1900-8PSK-High-H

RE\_FCC Test Case\_FCC Part 22&24&27 30MHz-13GHz-H

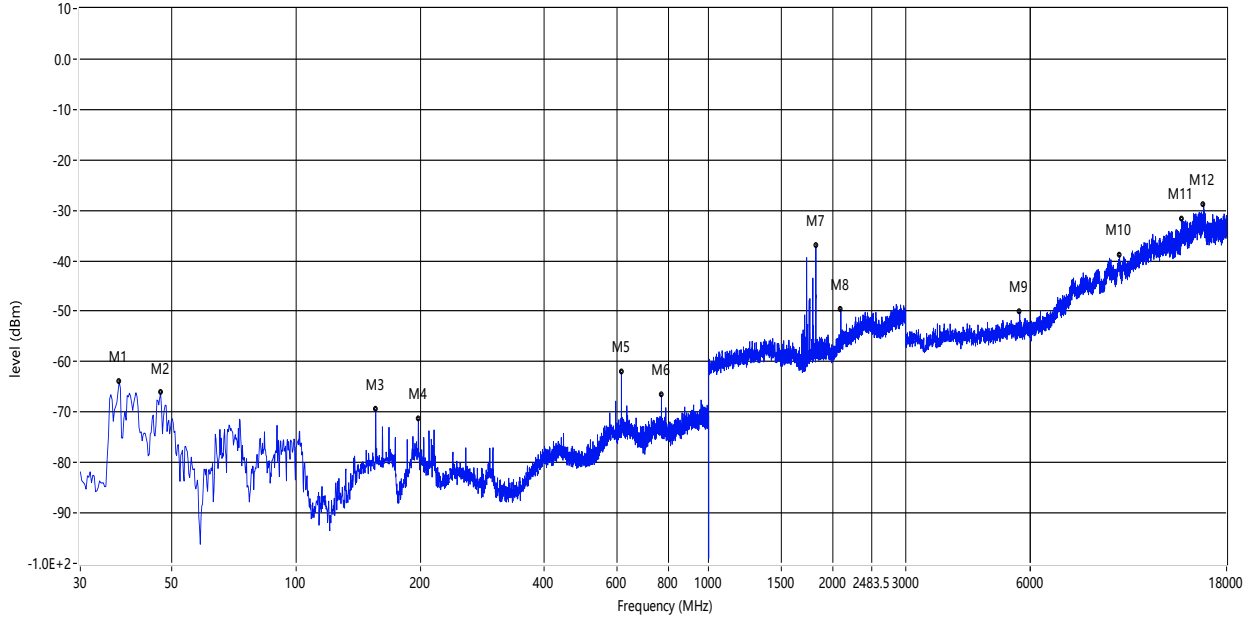

Frequency (MHz)	Result (dBm)	Limit (dBm)	Over Limit (dB)	ANT	Verdict
37.275	-64.00	-13.0	-51.00	Horizontal	Pass
46.975	-66.23	-13.0	-53.23	Horizontal	Pass
155.858	-69.56	-13.0	-56.56	Horizontal	Pass
198.053	-71.38	-13.0	-58.38	Horizontal	Pass
614.425	-62.17	-13.0	-49.17	Horizontal	Pass
768.170	-66.61	-13.0	-53.61	Horizontal	Pass
1819.000	-37.11	-13.0	-24.11	Horizontal	Pass
2091.000	-49.61	-13.0	-36.61	Horizontal	Pass
5675.000	-50.22	-13.0	-37.22	Horizontal	Pass
9907.500	-39.02	-13.0	-26.02	Horizontal	Pass
14057.500	-31.84	-13.0	-18.84	Horizontal	Pass
15831.250	-28.79	-13.0	-15.79	Horizontal	Pass



EGPRS 1900-8PSK-High-V

RE\_FCC Test Case\_FCC Part 22&24&27 30MHz-13GHz-V

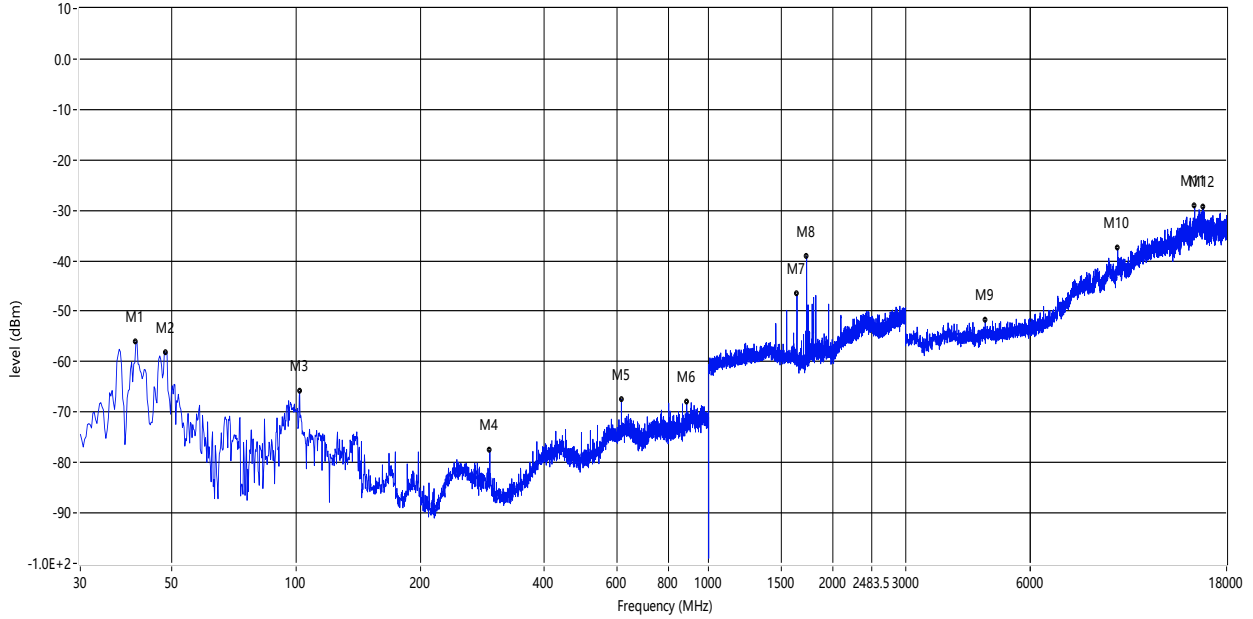

Frequency (MHz)	Result (dBm)	Limit (dBm)	Over Limit (dB)	ANT	Verdict
40.913	-56.03	-13.0	-43.03	Vertical	Pass
48.430	-58.14	-13.0	-45.14	Vertical	Pass
102.022	-65.91	-13.0	-52.91	Vertical	Pass
294.810	-77.65	-13.0	-64.65	Vertical	Pass
614.425	-67.48	-13.0	-54.48	Vertical	Pass
884.812	-68.09	-13.0	-55.09	Vertical	Pass
1636.500	-46.65	-13.0	-33.65	Vertical	Pass
1728.000	-39.08	-13.0	-26.08	Vertical	Pass
4680.000	-51.80	-13.0	-38.80	Vertical	Pass
9805.000	-37.55	-13.0	-24.55	Vertical	Pass
15068.750	-29.23	-13.0	-16.23	Vertical	Pass
15825.000	-29.34	-13.0	-16.34	Vertical	Pass



## APPENDIX-PHOTOS OF TEST SETUP

Note: See test photos in setup photo document for the actual connections between Product and support equipment.

※※※※END OF THE REPORT※※※※

