

FCC Test Report

for

Borescope

Model No. : VS70
FCC ID : ZLV-VS
Report Number : S1RF- T400-1102-100
Date of Receipt : August 18, 2013
Date of Report : December 18, 2013

Prepared for

FLIR Systems AB

Box 7376, SE-187 15 Täby, Sweden

Prepared by



Central Research Technology Co.

EMC Test Laboratory

No.11, Lane41, Fushuen St., Jungshan Chiu, Taipei, Taiwan, 104, R.O.C.



NVLAP LAB CODE 200575-0

This report shall not be reproduced, except in full, without the written approval of Central Research Technology Co.. It may be duplicated completely in its entirety for legal use with the permission of the applicant. It should not be used to claim product endorsement by NVLAP, NIST or any U.S. government agency. The test result in the report applies only to the sample tested.

Verification of Compliance

Equipment under Test : Borescope
Model No. : VS70
FCC ID : ZLV-VS
Applicant : FLIR Systems AB
Address : Box 7376, SE-187 15 Täby, Sweden
Applicable Standards : 47 CFR part 15, Subpart C
Date of Testing : August 29~September 2, 2013
Deviation : N/A
Condition of Test Sample : Engineering Sample

We, **Central Research Technology Co.**, hereby certify that one sample of the designated product was tested in our facility during the period mentioned above. The test records, data evaluation and Equipment Under Test (EUT) configurations shown in the present report are true and accurate representation of the measurements of the sample's RF characteristics under the conditions herein specified.

The test results show that the EUT as described in the present report is in compliance with the requirements set forth in the standards mentioned above and apply to the tested sample identified in the present report only. The test report shall not be reproduced, except in its entirety, without the written approval of Central Research Technology Co.

PREPARED BY : Cathy Chen , DATE : Dec. 18, 2013
(Cathy Chen/Technical Manager)

APPROVED BY : J. Y. Shih , DATE : Dec. 18, 2013
(Tsun-Yu Shih/General Manager)

Contents

1 General Description4

1.1 General Description of EUT.....4

1.2 Applied standards5

1.3 The Support Units8

1.4 Layout of Setup8

1.5 Test Capability9

1.6 Measurement Uncertainty 11

2 Field Strength of Fundamental.....12

2.1 Applied standard 12

2.2 Test Instruments 12

2.3 Measurement Procedure 13

2.4 Test configuration 14

2.5 Test Data 15

3 Radiated Emission Measurement18

3.1 Limit for Radiated Emission Measurement..... 18

3.2 Test Instruments 19

3.3 Test Procedures 20

3.4 Test Configuration 21

3.5 Test Results 22

4 Antenna Requirement.....31

4.1 Applied standard 31

4.2 Antenna Information 31

4.3 Result 31

Attachment 1 – Photographs of the Test Configurations

Attachment 2 –External Photographs of EUT

Attachment 3 –Internal Photographs of EUT

1 General Description

1.1 General Description of EUT

Equipment under Test : Borescope
Model No. : VS70
Power in : 3.7Vdc by the internal battery
Test Voltage : 3.7Vdc by the internal battery
Channel Numbers : 1
Frequency Range : 2468MHz
Modulation : FM
Function Description :

The EUT is used to transmit both control command and data. Please refer to the user's manual for the details.

Perform the function of EUT continuously by executing the test program supplied by manufacturer.

Since the EUT is considered a portable unit, it was pre-tested on the positioned in each of 3 axis. Therefor only the test data of the worse case - X axiz was used for Radiated test.

1.2 Applied standards

(1) Conduction Emission Requirement

For intentional device, according to §15.207(a) line conduction emission limit is as below table.

Frequency of Emission (MHz)	Conducted Limit (dBuV)	
	Quasi-peak	Average
0.15 – 0.5	66 to 56*	56 to 46*
0.5 - 5	56	46
5 - 30	60	50

* Decreases with the logarithm of the frequency.

(2) Field strength of emissions

According to 15.249(a), the field strength of emissions from intentional radiators operated within these frequency bands shall comply with the following:

Fundamental Frequency	Field Strength of Fundamental (millivolts/meter)	Field Strength of Harmonics (microvolts/meter)
902 - 928 MHz	50	500
2400 - 2483.5 MHz	50	500
5725 - 5875 MHz	50	500
24.0 - 24.25 GHz	250	2500

(3) Radiated Emission Requirement

According to 15.249(d), Emissions radiated outside of the specified frequency bands, except for harmonics, shall be attenuated by at least 50 dB below the level of the fundamental or to the general radiated emission limits in Section 15.209, whichever is the lesser attenuation.

For intentional device, according to §15.209, the general requirement of field strength of radiated emissions from intentional radiator at a distance of 3 meters shall not exceed the below table.

Frequency (MHz)	Measurement Distance (m)	Field Strength (uV/m)	Field Strength (dBuV/m)
30 – 88	3	100	40.0
88 – 216	3	150	43.5
216 – 960	3	200	46.0
960 – 1610	3	500	54.0
above 1610	3	500	54.0

Note 1- The lower limit shall apply at the transition frequency.

(4) Antenna Requirement

An intentional radiator shall be designed to ensure that no antenna other than that furnished by the responsible party shall be used with the device. The use of a permanently attached antenna or of an antenna that uses a unique coupling to the intentional radiator shall be considered sufficient to comply with the provisions of this Section. The manufacturer may design the unit so that a broken antenna can be replaced by the user, but the use of a standard antenna jack or electrical connector is prohibited. This requirement does not apply to carrier current devices or to devices operated under the provisions of Sections 15.211, 15.213, 15.217, 15.219, or 15.221. Further, this requirement does not apply to intentional radiators that must be professionally installed, such as perimeter protection systems and some field disturbance sensors, or to other intentional radiators which, in accordance with Section 15.31(d), must be measured at the installation site. However, the installer shall be responsible for ensuring that the proper antenna is employed so that the limits in this Part are not exceeded.

(5) Restricted Band

Frequency (MHz)	Frequency (MHz)	Frequency (MHz)	Frequency (MHz)
0.090 - 0.110	16.42 - 16.423	399.9 - 410	4.5 - 5.15
¹ 0.495 - 0.505	16.69475 - 16.69525	608 - 614	5.35 - 5.46
² 1735 - 2.1905	16.80425 - 16.80475	960 - 1240	7.25 - 7.75
4.125 - 4.128	25.5 - 25.67	1300 - 1427	8.025 - 8.5
4.17725 - 4.17775	37.5 - 38.25	1435 - 1626.5	9.0 - 9.2
4.20725 - 4.20775	73 - 74.6	1645.5 - 1646.5	9.3 - 9.5
6.215 - 6.218	74.8 - 75.2	1660 - 1710	10.6 - 12.7
6.26775 - 6.26825	108 - 121.94	1718.8 - 1722.2	13.25 - 13.4
6.31175 - 6.31225	123 - 138	2200 - 2300	14.47 - 14.5
8.291 - 8.294	149.9 - 150.05	2310 - 2390	15.35 - 16.2
8.362 - 8.366	156.52475 - 156.52525	2483.5 - 2500	17.7 - 21.4
8.37625 - 8.38675	156.7 - 156.9	2690 - 2900	22.01 - 23.12
8.41425 - 8.41475	162.0125 - 167.17	3260 - 3267	23.6 - 24.0
12.29 - 12.293	167.72 - 173.2	3332 - 3339	31.2 - 31.8
12.51975 - 12.52025	240 - 285	3345.8 - 3358	36.43 - 36.5
12.57675 - 12.57725	322 - 335.4	3600 - 4400	(2)
13.36 - 13.41			

¹ Until February 1, 1999, this restricted band shall be 0.490-0.510 MHz.

² Above 38.6

1.3 The Support Units

No.	Unit	Model No./ Serial No.	Trade Name	Power Cord	Supported by lab.
N/A	*	*	*	*	*

1.4 Layout of Setup



Connecting Cables :

No.	Cable	Length	Shielded	Core	Shielded Backshell	Supported by lab.	Note
N/A	*	*	*	*	*	*	*

1.5 Test Capability

Test Facility

The test facility used for evaluating the conformance of the EUT with each standard in the present report meets what required in CISPR16-1-4, CISPR16-2-3 and ANSI C63.4:2003.

Test Room	Type of Test Room	Descriptions
TR1	10m semi-anechoic chamber (23m×14m×9m)	Complying with the NSA requirements in documents CISPR 22 and ANSI C63.4:2003 for the radiated emission measurement.
TR11	3m semi-anechoic chamber (9m × 6m × 6m)	
TR13	Test Site	For the RF conducted emission measurement.
TR5	Shielding Room (8m×5m×4m)	For the conducted emission measurement.

Test Laboratory Competence Information

Central Research Technology Co. has been accredited / filed / authorized by the agencies listed in the following table.

Certificate	Nation	Agency	Code	Mark
Accreditation Certificate	USA	NVLAP	200575-0	ISO/IEC 17025
	R.O.C. (Taiwan)	TAF	0905	ISO/IEC 17025
	R.O.C. (Taiwan)	BSMI	SL2-IN-E-0033, SL2-IS-E-0033, SL2-R1/R2-E-0033, SL2-A1-E-0033 SL2-L1-E-0033	ISO/IEC 17025
Site Filing Document	USA	FCC	474046, TW1053	Test facility list & NSA Data
	Canada	IC	4699A-1, -3	Test facility list & NSA Data
	Japan	VCCI	R-1527,C-1609,T-1441, G-10, C-4400, G-614, T-1334	Test facility list & NSA Data
Authorization Certificate	Germany	TUV	10021687	ISO/IEC 17025
	Norway	Nemko	ELA212	ISO/IEC 17025

The copy of each certificate can be downloaded from our web site: www.crc-lab.com

1.6 Measurement Uncertainty

The assessed measurement uncertainty with a suitable coverage factor K to ensure 95% confidence level for the normal distribution are shown as below, the values are less than U_{cispr} in table 1 of CISPR 16-4-2.

Test Item	Measurement Uncertainty	
Radiated Emission: (30MHz~200MHz)	Horizontal 3.5dB ; Vertical 3.8dB	
Radiated Emission: (200MHz~1GHz)	Horizontal 3.9dB ; Vertical 3.9dB	
Radiated Emission: (1GHz~18GHz)	Horizontal 3.5dB ; Vertical 3.6dB	
Radiated Emission: (18GHz~26.5GHz)	Horizontal 4.4dB ; Vertical 4.5dB	
Line Conducted Emission	ESH2-Z5	3.1dB
	ENV 4200	2.8dB

2 Field Strength of Fundamental

Result: Pass

2.1 Applied standard

Fundamental Frequency	Peak	Average
<input type="checkbox"/> 902 – 928 MHz	500mV/m (114dBuV/m)	50mV/m (94dBuV/m)
<input checked="" type="checkbox"/> 2400 – 2483.5 MHz	500 mV/m (114dBuV/m)	50 mV/m (94dBuV/m)
<input type="checkbox"/> 5725 – 5875 MHz	500 mV/m (114dBuV/m)	50 mV/m (94dBuV/m)
<input type="checkbox"/> 24.0 – 24.25 GHz	2500 mV/m (128dBuV/m)	250 mV/m (108dBuV/m)

2.2 Test Instruments

Test Site and Equipment	Manufacturer	Model No./ Serial No.	Last Calibration Date	Calibration Due Date
Spectrum Analyzer	Agilent	E4407B/ MY45106795	May 29, 2013	May 29, 2014
Antenna	EMCO	3117/ 82847	March 5, 2013	March 5, 2014
PRE-AMPLIFIER	MITEQ	JS4-00101800-28-5 A/742229	Dec. 14, 2012	Dec. 14, 2013
RF Cable	N/A	N/A/ C0081	Aril 15, 2013	Oct. 15, 2013
Semi - anechoic Chamber	ETS. LINDGREN	TR11/ 906-A	May 11, 2013	May 11, 2014

Note:

1. The calibrations are traceable to NML/ROC.
2. NCR:No Calibration Required.

Instrument Setting

RBW	VBW	Detector	Trace	Comment
1MHz	1MHz	Peak	Maxhold	Peak
1MHz	10Hz	Peak	Maxhold	Average

Climatic Condition

Ambient Temperature : 28°C

Relative Humidity : 54%

2.3 Measurement Procedure

- a. The EUT was set up per the test configuration figured in the next section of this chapter to simulate the typical usage per the user's manual.
- b. A software provided by client enabled the EUT to transmit and receive data at operating frequency.(if necessary)
- c. If the EUT is tabletop equipment, it should be placed on a wooden table with a height of 0.8 meters above the reference ground plane in the semi-anechoic chamber. If the EUT is floor-standing equipment, it should be placed on a non-conducted support with a height of 12 millimeters above the reference ground plane in the semi-anechoic chamber.
- d. The EUT is set 3m away from the receiving antenna.
- e. Rapidly sweep the signal in the test frequency range by using the spectrum through the Maximum-peak detector.
- f. Rotate the EUT from 0° to 360° and position the receiving antenna at heights from 1 to 4 meters above the reference ground plane continuously to determine higher emission level and record it.
- g. Then measure frequency found from step f. by using the spectrum with rotating the EUT and positioning the receiving antenna height to determine the maximum level.
- h. Set the spectrum detector to be Peak or Average to find out the maximum level occurred.
- i. Record frequency, azimuth angle of the turntable, height, and polarization of the receiving antenna and compare the maximum level with the required limit.
- j. Change the receiving antenna to another polarization to measure radiated emission by following step e. to i. again.

2.4 Test configuration

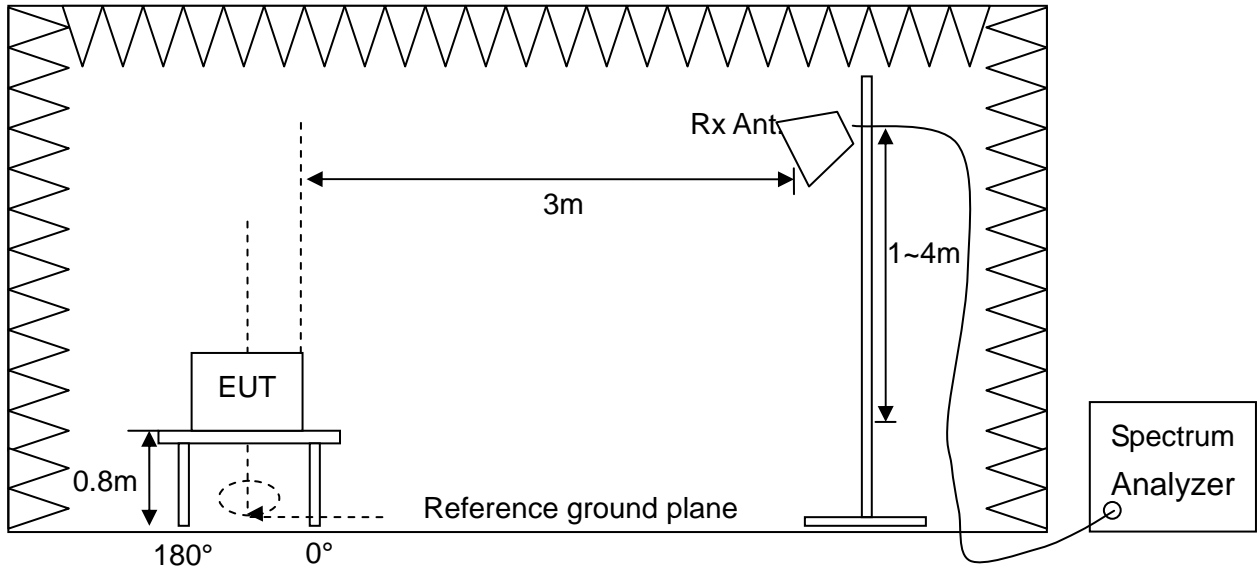

2.5 Test Data

Test Mode : Continuous Transmitting

Tester : Liu

Operation Frequency (MHz)	Polarization	Reading Data (dBuV)		Correction Factor (dB/m)	Output Field Strength (dBμV/m)		Limit (dBμV/m)		Margin (dB)	
		PK	AV		PK	AV	PK	AV	PK	AV
2468	H	96.11	90.68	1.20	97.31	91.88	114	94	16.69	2.12
	V	93.96	86.98	1.19	95.15	88.17	114	94	18.85	5.83

Note :

1. Correction Factor (dB/m) = Cable Loss + Antenna Factor – Gain of Preampfier
2. Output Field Strength (dBuV/m) = Reading Data + Correction Factor
3. Margin (dB) = Limit – Output Field Strength

Horizontal Polarization - Peak

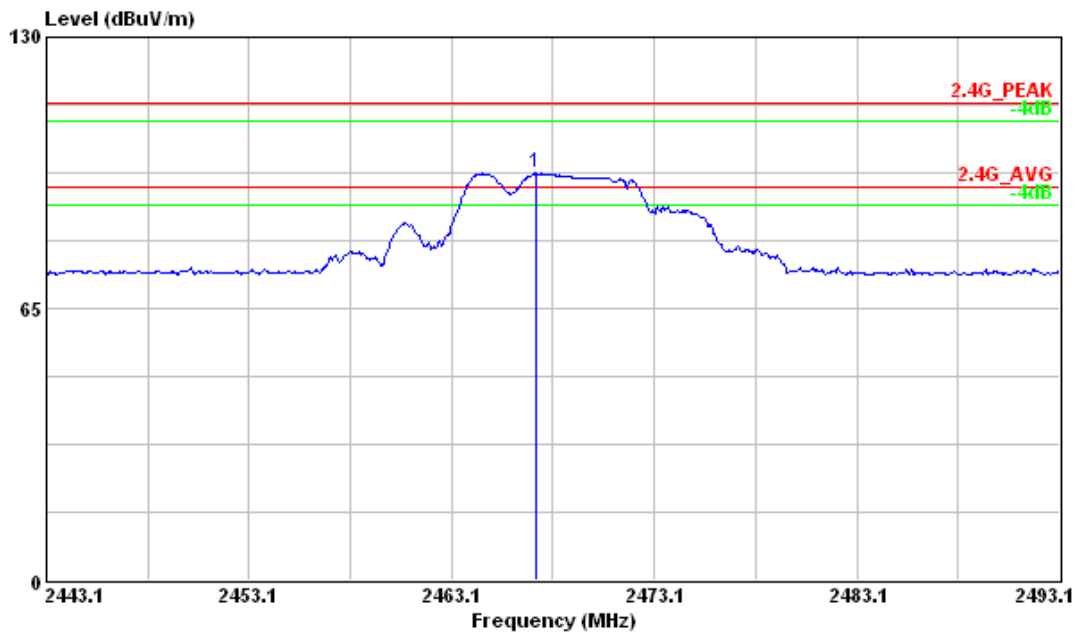

Horizontal Polarization - Average

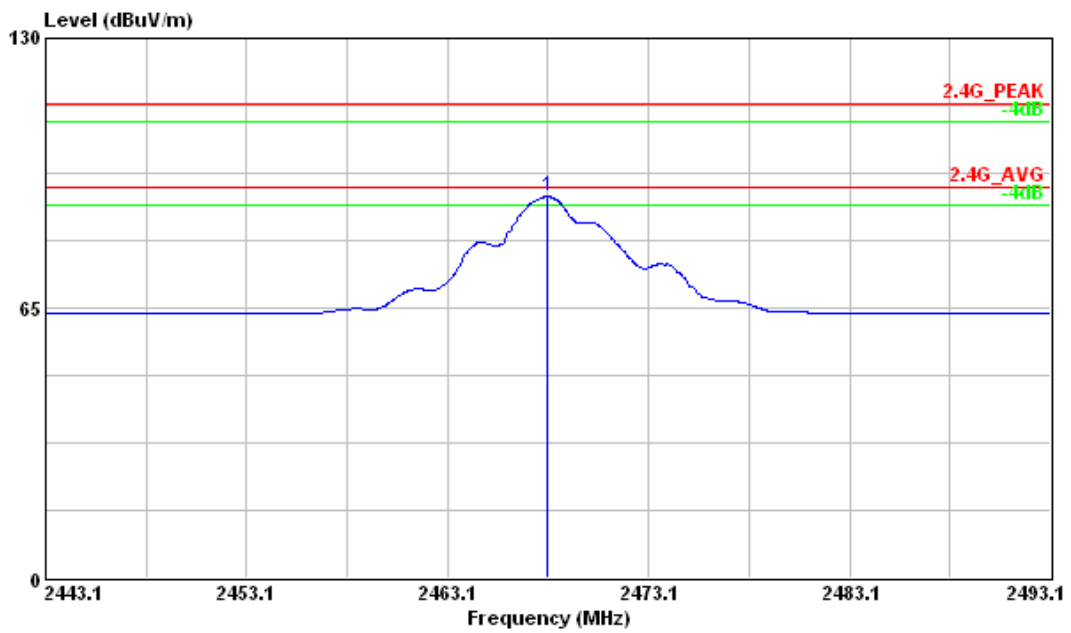

Vertical Polarization - Peak

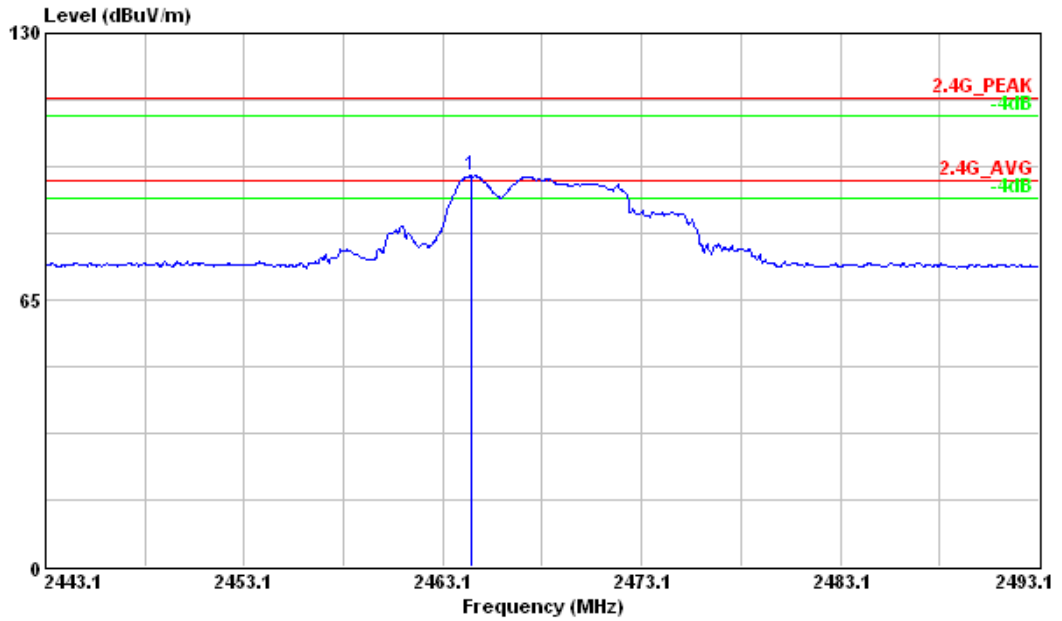

Vertical Polarization - Average

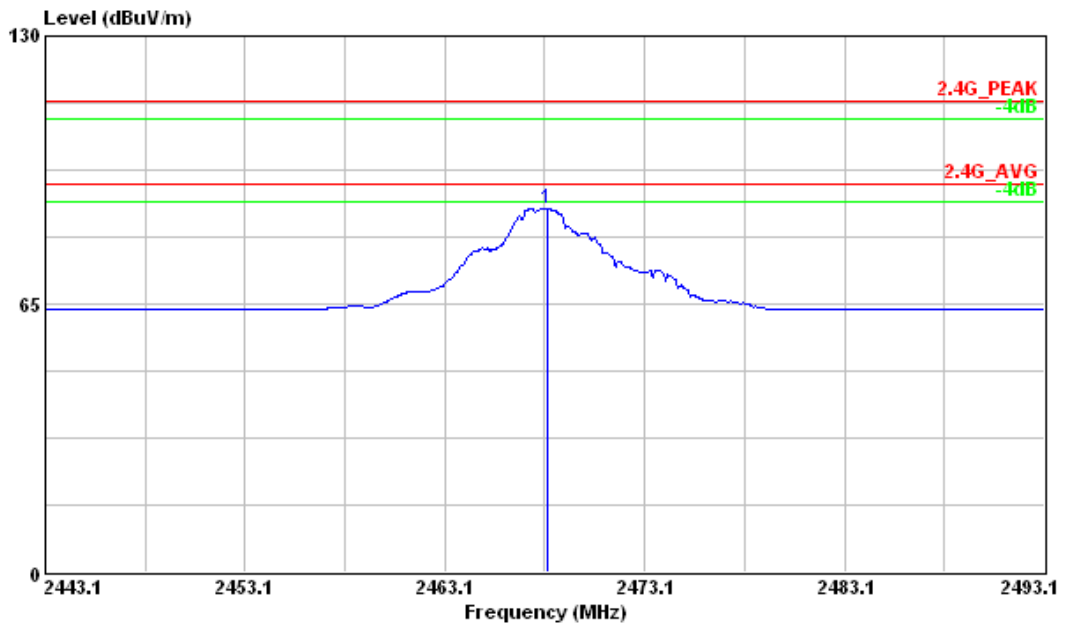

3 Radiated Emission Measurement

Result: PASS

3.1 Limit for Radiated Emission Measurement

Limit for Harmonics Radiation Emission Measurement

Fundamental Frequency	Field Strength of Harmonics
<input type="checkbox"/> 902 – 928 MHz	500 uV/m (54dBuV/m)
<input checked="" type="checkbox"/> 2400 – 2483.5 MHz	500 uV/m (54dBuV/m)
<input type="checkbox"/> 5725 – 5875 MHz	500 uV/m (54dBuV/m)
<input type="checkbox"/> 24.0 – 24.25 GHz	2500 uV/m(68dBuV/m)

Limit for Other Emissions except Harmonics

Frequency (MHz)	Quasi-peak (dBμV/m)	
30 to 88	40	
88 to 216	43.5	
216 to 960	46	
960 to 1000	54	
Frequency (MHz)	Peak (dBμV/m)	Average (dBμV/m)
Above 1000	74	54

Note 1- The lower limit shall apply at the transition frequency.
 Note 2- Additional provisions may be required for cases where interference occurs.

3.2 Test Instruments

Test Site and Equipment	Manufacturer	Model No./ Serial No.	Last Calibration Date	Calibration Due Date
Spectrum Analyzer	Agilent	E4407B/ MY45106795	May 29, 2013	May 29, 2014
EMI Test Receiver	R&S	ESCI/ 100019	July 7, 2013	July 7, 2014
Broadband Antenna	EMCO	3142C/ 52088	May 27, 2013	May 27, 2014
Antenna	EMCO	3117/ 82847	March 5, 2013	March 5, 2014
Pre-Amplifier	MITEQ	JS4-00101800-28-5 A/742229	Dec. 19, 2012	Dec. 19, 2013
Pre-Amplifier	MITEQ	JS4-00101800-28-1 0P/1498979	Dec. 14, 2012	Dec. 14, 2013
Pre-Amplifier	Mini Circuit	ZKL-2/ 004	Aug. 3, 2013	Aug. 3, 2014
RF Cable	N/A	N/A/ C0080	Aug. 3, 2013	Feb. 3, 2013
RF Cable	N/A	N/A/ C0081	Aril 15, 2013	Oct. 15, 2013
Semi - anechoic Chamber	ETS. LINDGREN	TR11/ 906-A	May 11, 2013	May 11, 2014

Note:

1. The calibrations are traceable to NML/ROC.
2. NCR:No Calibration Required.

Instrument Setting

RBW	VBW	Detector	Trace	Comment
120kHz	N/A	Quasi-Peak	Maxhold	Below 1GHz
1MHz	1MHz	Peak	Maxhold	Above 1GHz Peak
1MHz	10Hz	Peak	Maxhold	Above 1GHz Average

Climatic Condition

Ambient Temperature : 28°C; Relative Humidity : 52%

3.3 Test Procedures

- a. The EUT was set up per the test configuration figured in the next section of this chapter to simulate the typical usage per the user's manual.
- b. A software provided by client enabled the EUT to transmit and receive data at operating frequency.(if necessary)
- c. If the EUT is tabletop equipment, it should be placed on a wooden table with a height of 0.8 meters above the reference ground plane in the semi-anechoic chamber. If the EUT is floor-standing equipment, it should be placed on a non-conducted support with a height of 12 millimeters above the reference ground plane in the semi-anechoic chamber.
- d. The EUT is set 3m away from the interference receiving antenna.
- e. Rapidly sweep the signal in the test frequency range by using the spectrum through the Maximum-peak detector.
- f. Rotate the EUT from 0° to 360° and position the receiving antenna at heights from 1 to 4 meters above the reference ground plane continuously to determine at least six frequencies associated with higher emission levels and record them.
- g. Then measure each frequency found from step f. by using the spectrum with rotating the EUT and positioning the receiving antenna height to determine the maximum level.
- h. For measurement of frequency below 1000MHz, set the receiver detector to be Quasi-Peak per CISPR 16-1 to find out the maximum level occurred.
- i. For measurement of frequency above 1000MHz, set the spectrum detector to be Peak or Average to find out the maximum level occurred, if any.
- j. Record frequency, azimuth angle of the turntable, height, and polarization of the receiving antenna and compare the maximum level with the required limit.
- k. Change the receiving antenna to another polarization to measure radiated emission by following step e. to j. again.
- l. If the peak emission level below 1000MHz measured from step f. is 4dB lower than the limit specified, then the emission values presented will be the peak value only. Otherwise, accurate Q.P. value will be measured and presented.
- m. If the peak emission level above 1000MHz measured from step f. is 20dB lower than the limit specified, then the emission values presented will be the peak value only. Otherwise, accurate A.V. value will be measured and presented.

3.4 Test Configuration

Radiated Emission Measurement below 1000MHz

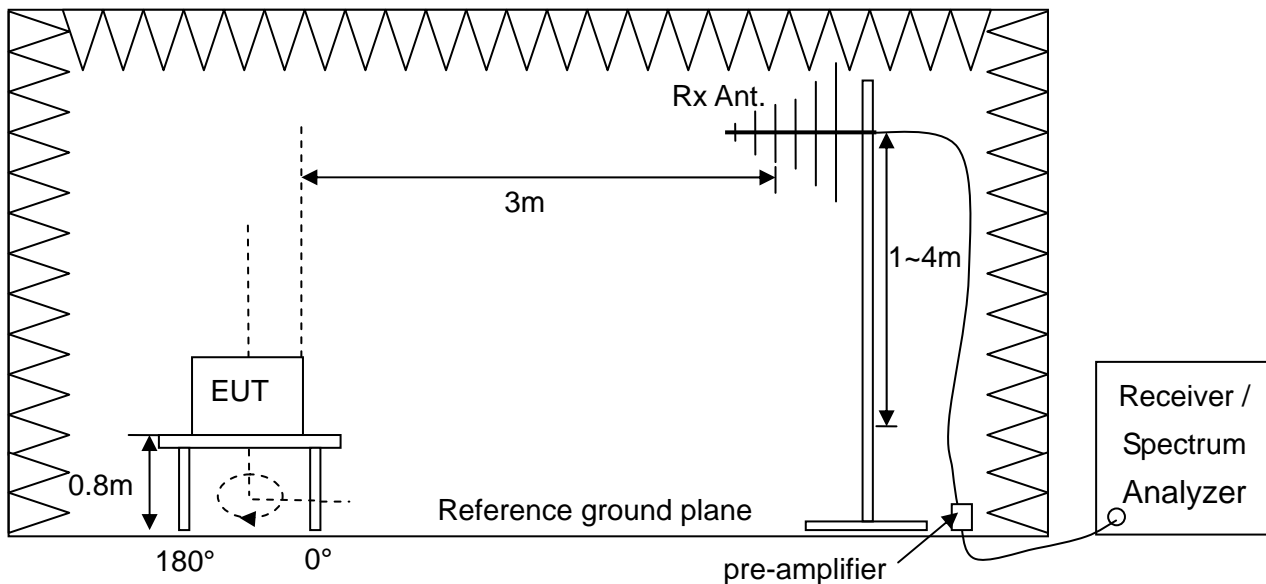

Radiated Emission Measurement above 1000MHz

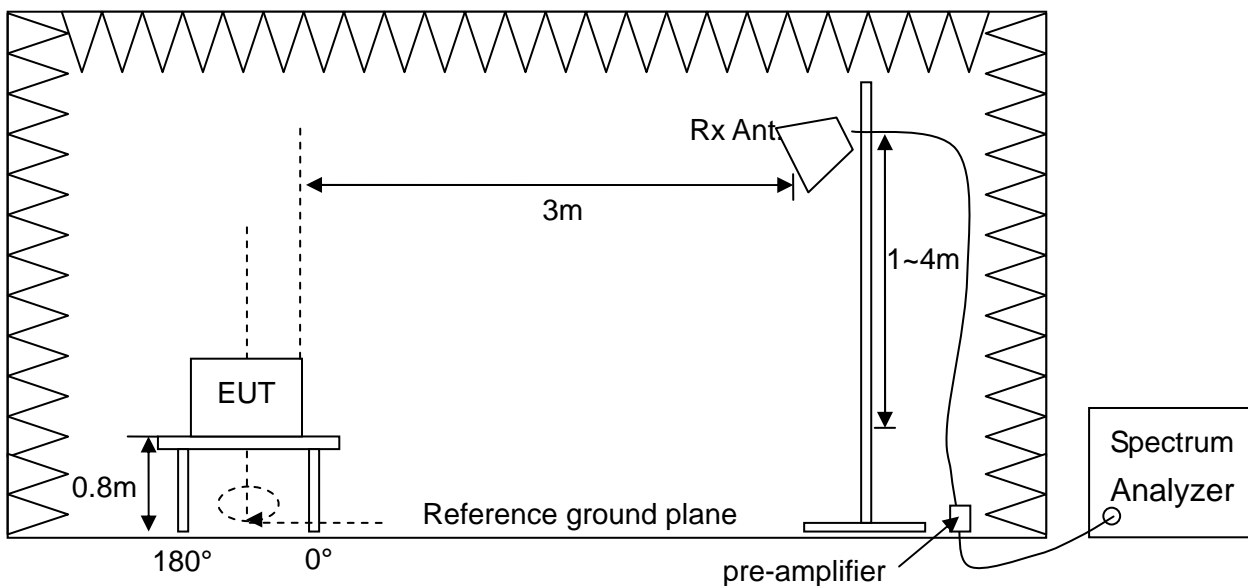

Lowest Channel, Horizontal - Peak

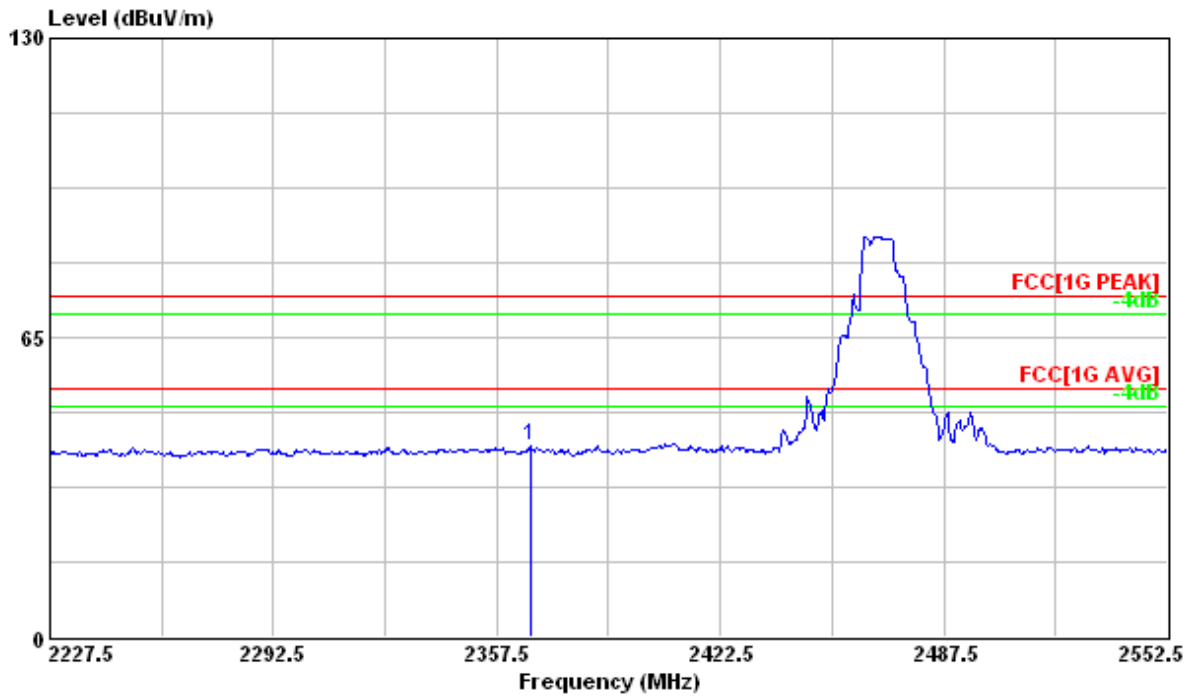

Lowest Channel, Horizontal - Average

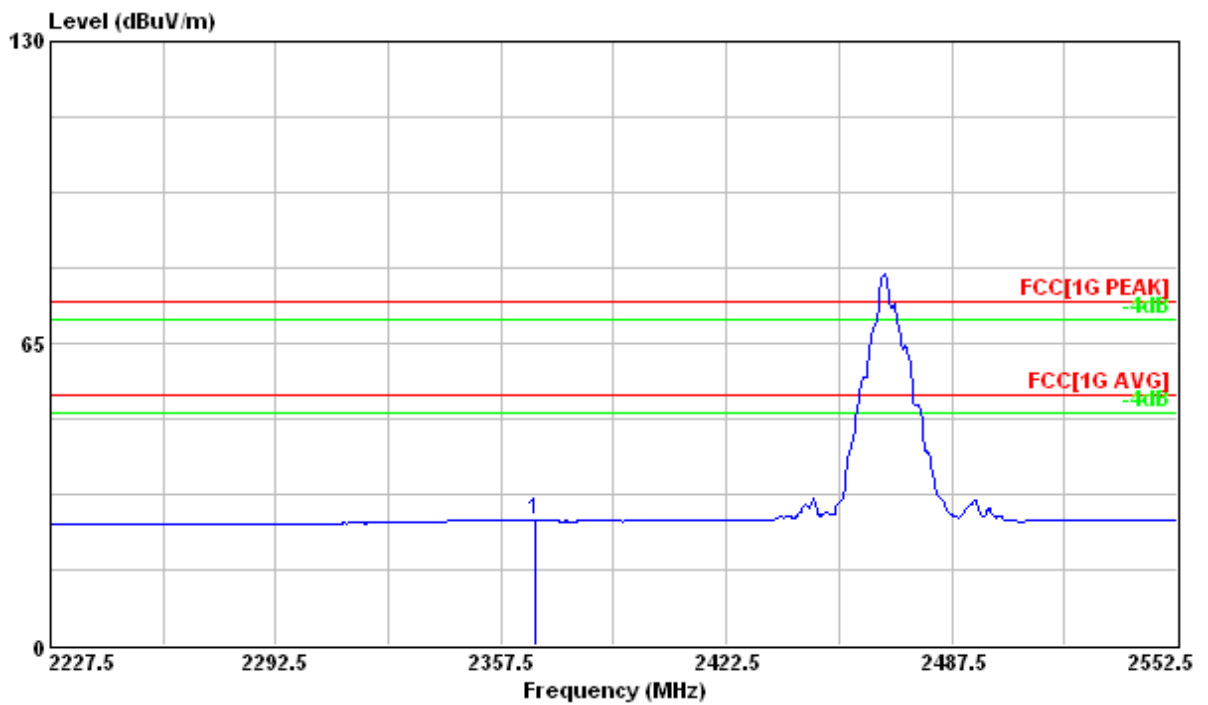

Lowest Channel, Vertical - Peak

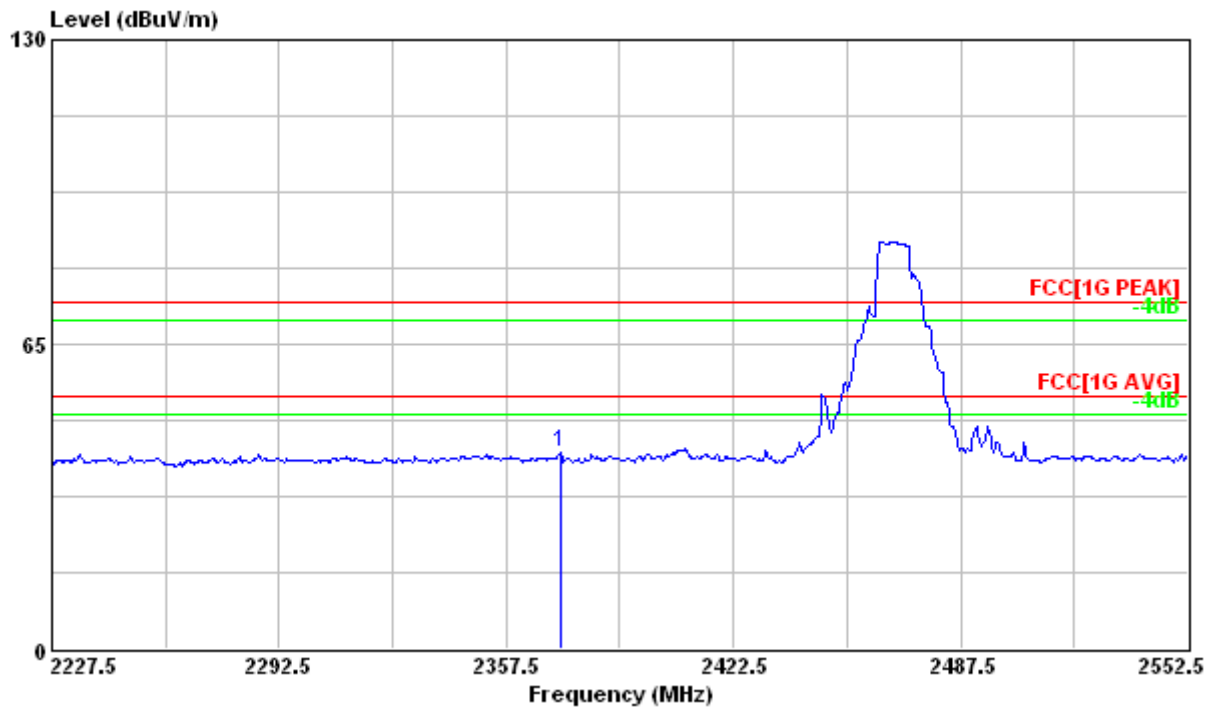

Lowest Channel, Vertical - Average

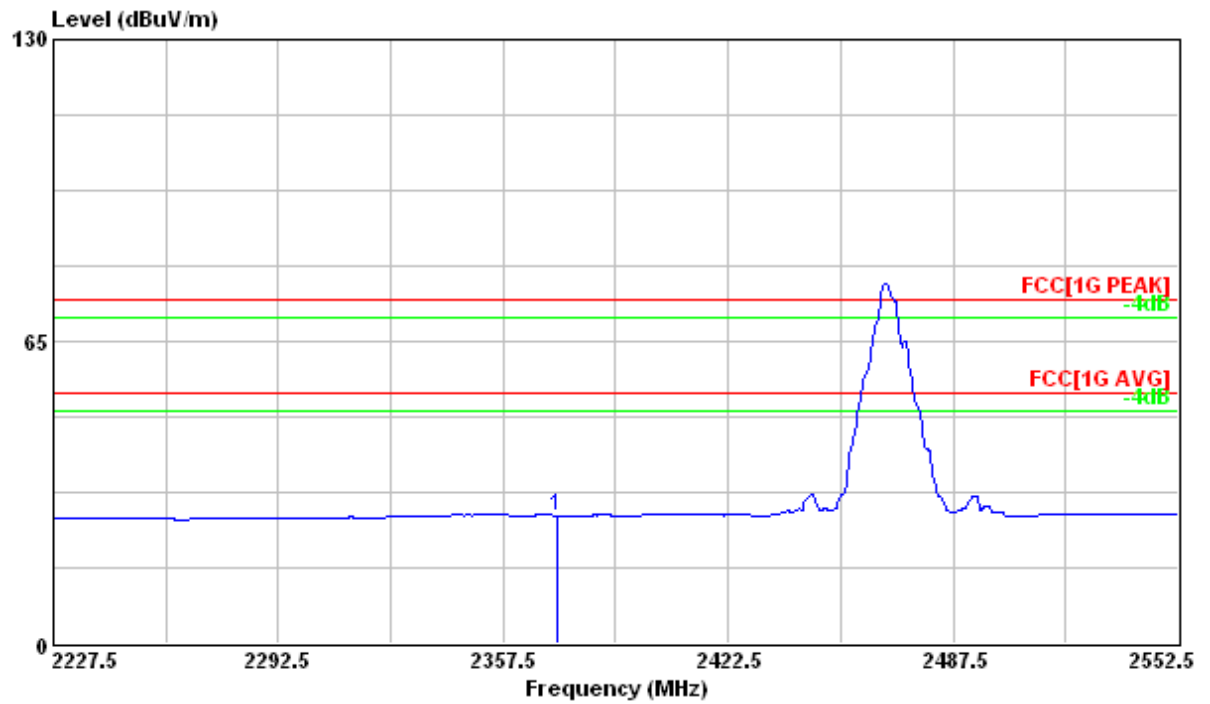

Highest Channel, Horizontal - Peak

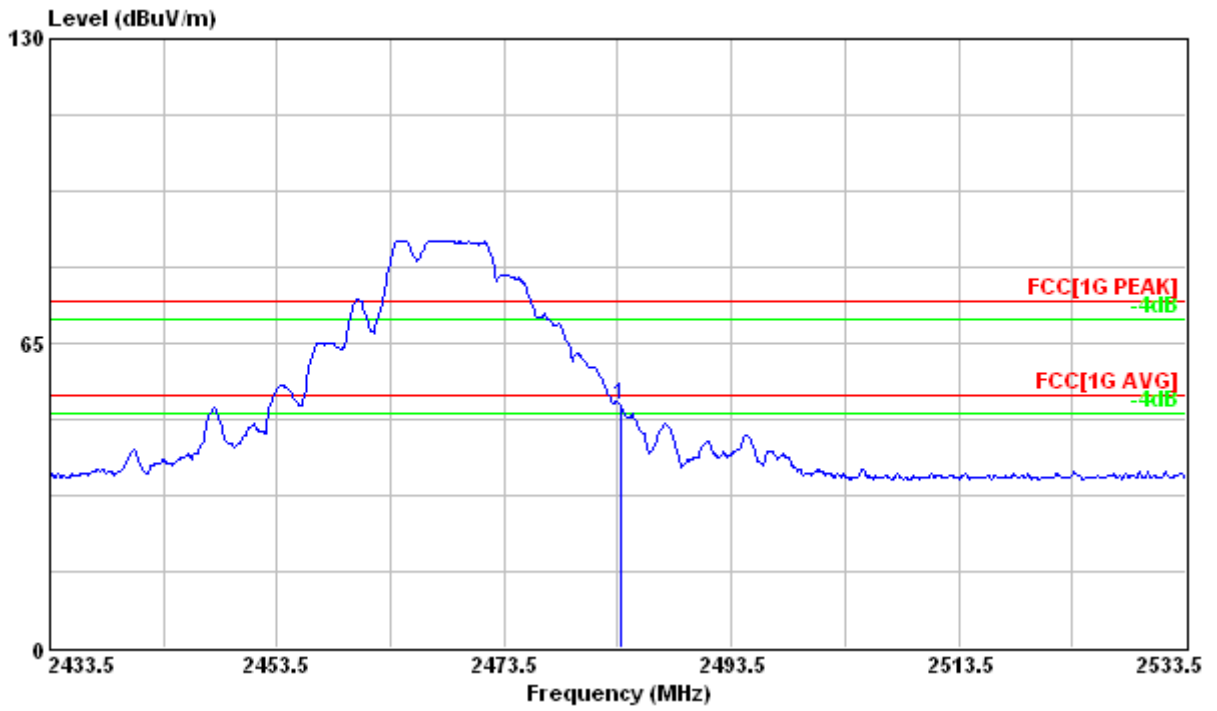

Highest Channel, Horizontal - Average

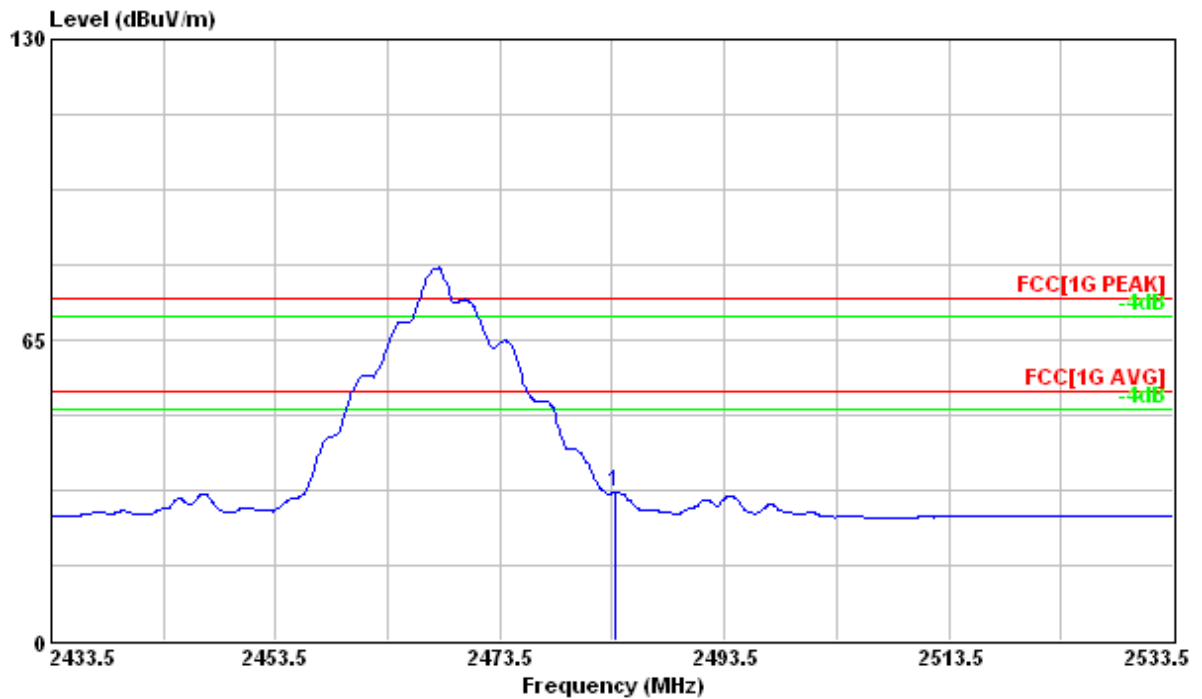

Highest Channel, Vertical - Peak

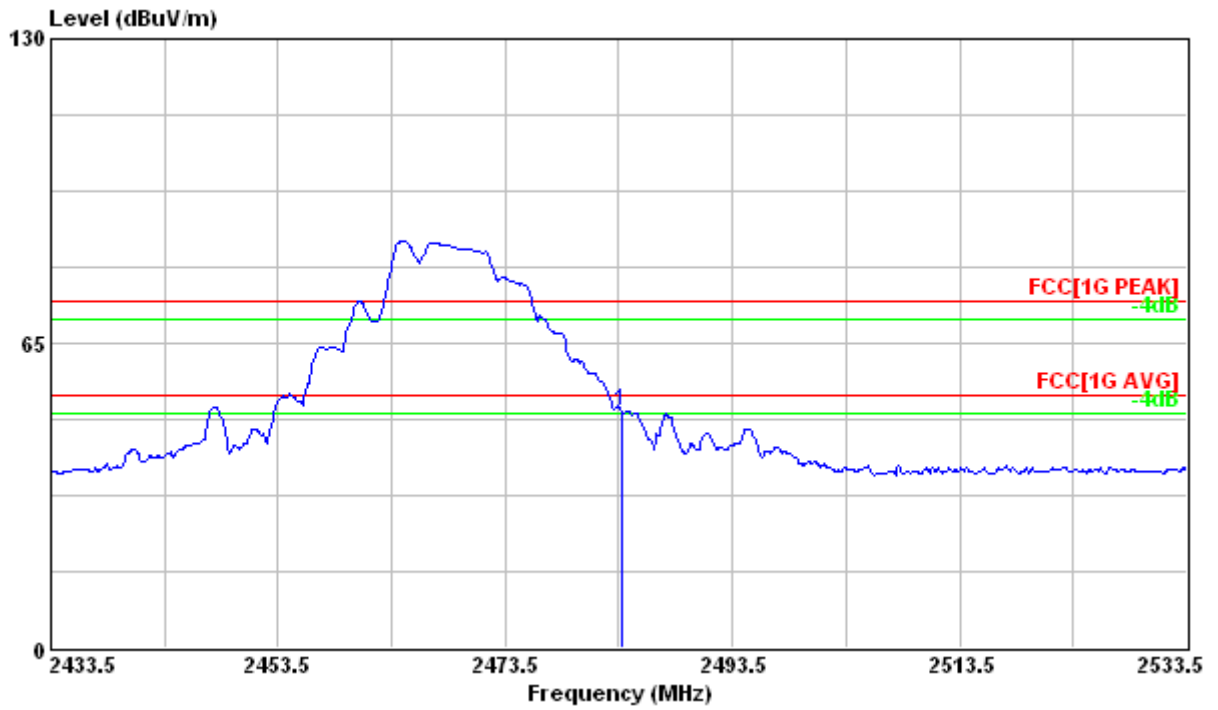

Highest Channel, Vertical - Average

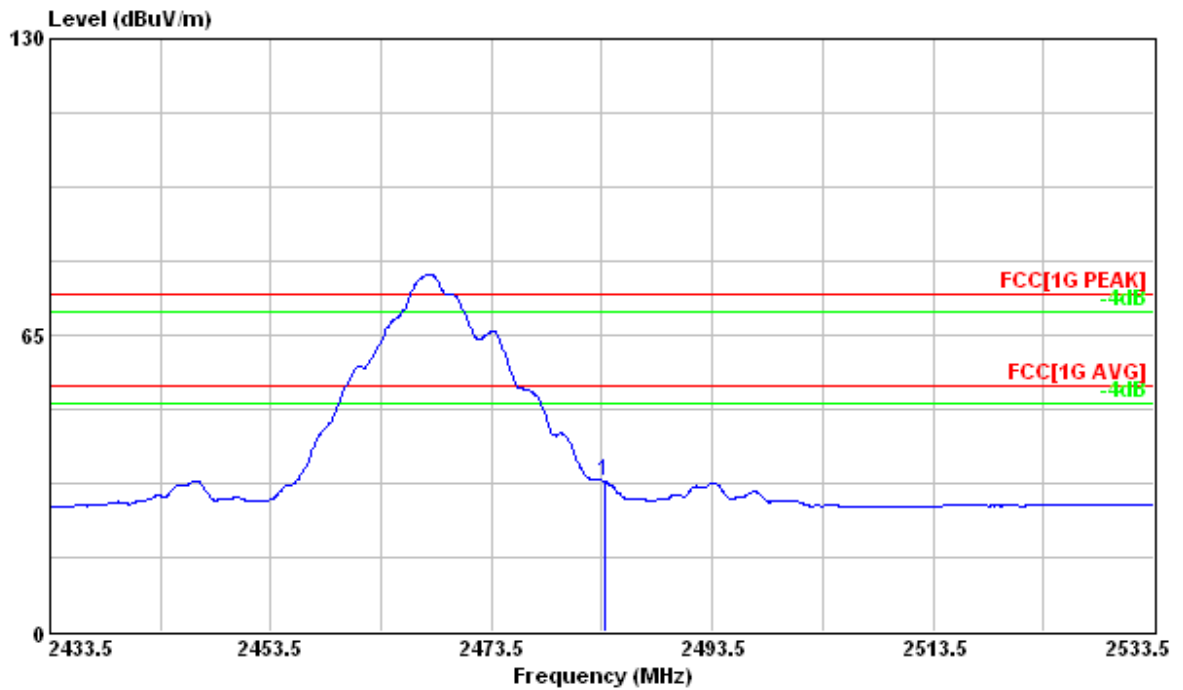

Transmitter Radiated Emission Measurement

Below 1000MHz

Test Mode : Continuous Transmitting
Test Distance : 3m **Tester** : Liu
Polarization : Horizontal **Frequency Range** : 30MHz~1000MHz

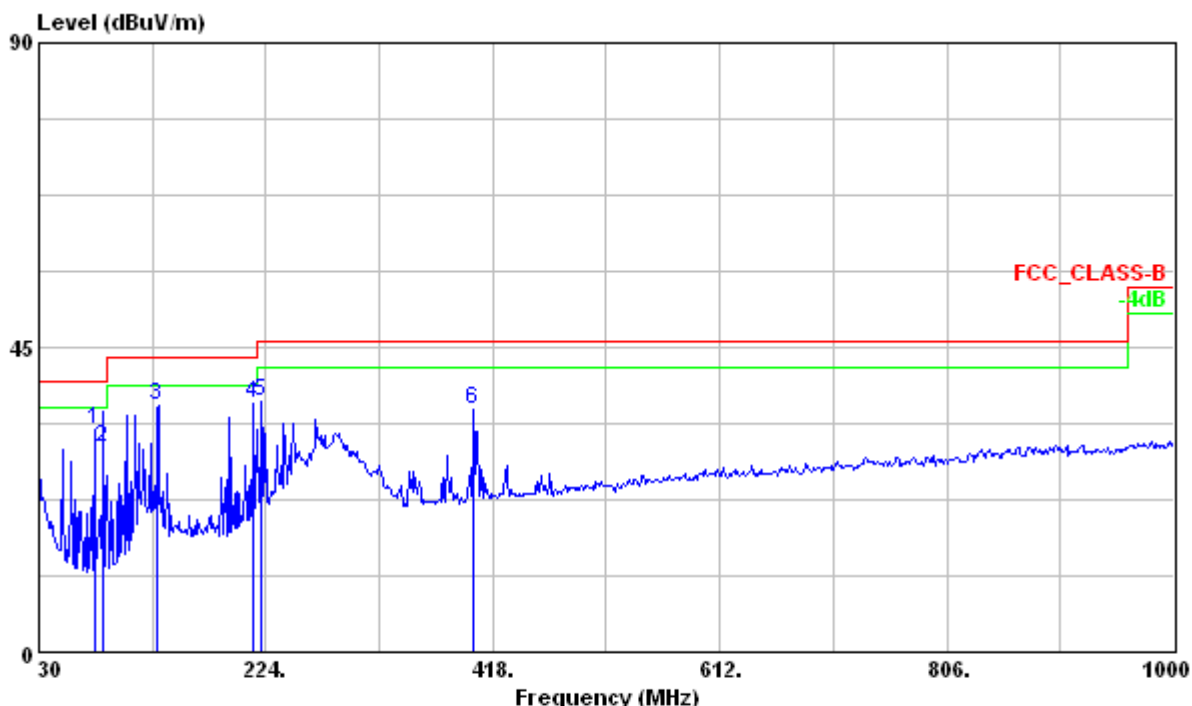

	Freq	Level	Read Level	Limit	Over	Ant	Table		
	MHz	dBuV/m	dBuV	dB/m	dBuV/m	dB	cm	deg	Remark
1	77.250	32.80	52.82	-20.02	40.00	-7.20	---	---	HORIZONTAL Peak
2	84.579	30.08	49.80	-19.72	40.00	-9.92	242	360	HORIZONTAL QP
3	131.250	36.28	55.42	-19.14	43.50	-7.22	---	---	HORIZONTAL Peak
4	212.520	36.61	52.08	-15.47	43.50	-6.89	---	---	HORIZONTAL Peak
5	220.080	37.07	52.06	-14.99	46.00	-8.93	---	---	HORIZONTAL Peak
6	401.500	35.87	44.82	-8.95	46.00	-10.13	---	---	HORIZONTAL Peak

Note:

1. Emission Level = reading value + correction factor.
2. Correction factor = cable loss + antenna factor – gain of pre-amplifier.
3. Q.P is abbreviation of quasi-peak.

Test Mode : Continuous Transmitting
 Test Distance : 3m Tester : Liu
 Polarization : Vertical Frequency Range : 30MHz~1000MHz

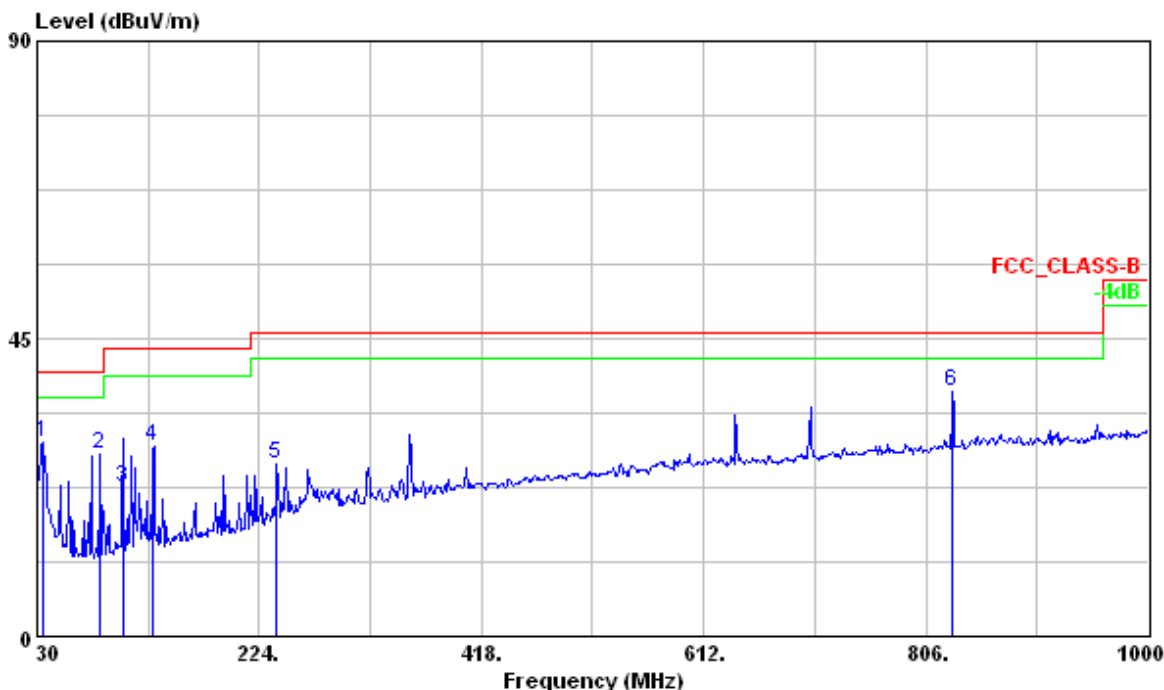

	Freq	Level	Read Level	Factor	Limit Line	Over Limit	Ant Pos	Table Pos	Pol/Phase	Remark
	MHz	dBuV/m	dBuV	dB/m	dBuV/m	dB	cm	deg		
1	34.590	29.27	40.64	-11.37	40.00	-10.73	---	---	VERTICAL	Peak
2	84.540	27.56	47.28	-19.72	40.00	-12.44	---	---	VERTICAL	Peak
3	104.421	22.55	41.41	-18.86	43.50	-20.95	100	71	VERTICAL	QP
4	131.250	28.69	47.83	-19.14	43.50	-14.81	---	---	VERTICAL	Peak
5	239.520	26.11	40.24	-14.13	46.00	-19.89	---	---	VERTICAL	Peak
6	829.200	37.11	39.31	-2.20	46.00	-8.89	---	---	VERTICAL	Peak

Note:

1. Emission Level = reading value + correction factor.
2. Correction factor = cable loss + antenna factor – gain of pre-amplifier.
3. Q.P is abbreviation of quasi-peak.

Above 1000MHz

Test Mode : Continuous transmitting
 Test Distance : 3m Tester : Liu
 Polarization : Horizontal Frequency Range : 1GHz ~ 25GHz

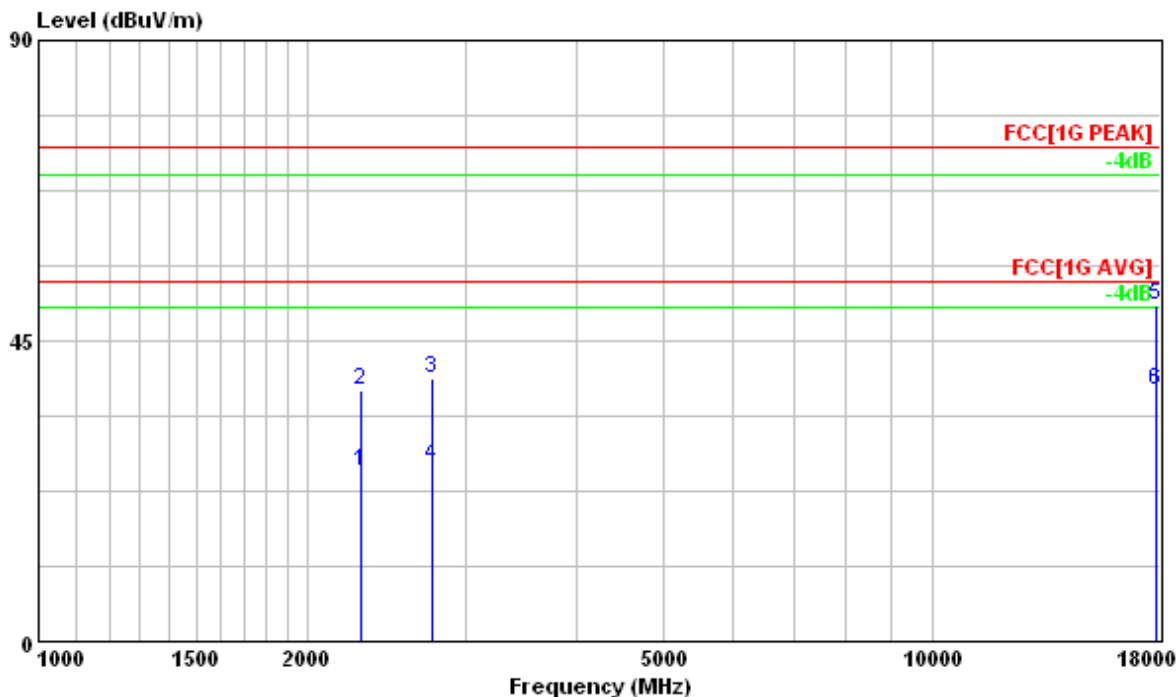

	Freq	Level	Read Level	Limit	Over	Ant	Table	Table	Remark
	MHz	dBuV/m	dBuV	dB/m	dBuV/m	dB	cm	deg	
1	2299.000	25.48	61.90	-36.42	54.00	-28.52	100	240	HORIZONTAL Average
2	2299.000	37.54	73.96	-36.42	74.00	-36.46	100	240	HORIZONTAL Peak
3	2755.148	39.28	74.69	-35.41	74.00	-34.72	101	234	HORIZONTAL Peak
4	2755.148	26.41	61.82	-35.41	54.00	-27.59	101	234	HORIZONTAL Average
5	17838.720	50.47	57.31	-6.84	74.00	-23.53	124	84	HORIZONTAL Peak
6	17838.720	37.64	44.48	-6.84	54.00	-16.36	124	84	HORIZONTAL Average

Note:

1. Emission Level = reading value + correction factor.
2. Correction factor = cable loss + antenna factor – gain of pre-amplifier.

No signal can be detected from 18GHz to 25GHz, so the graphs are omitted above 18GHz.

Test Mode : Continuous transmitting
 Test Distance : 3m Tester : Liu
 Polarization : Vertical Frequency Range : 1GHz ~ 25GHz

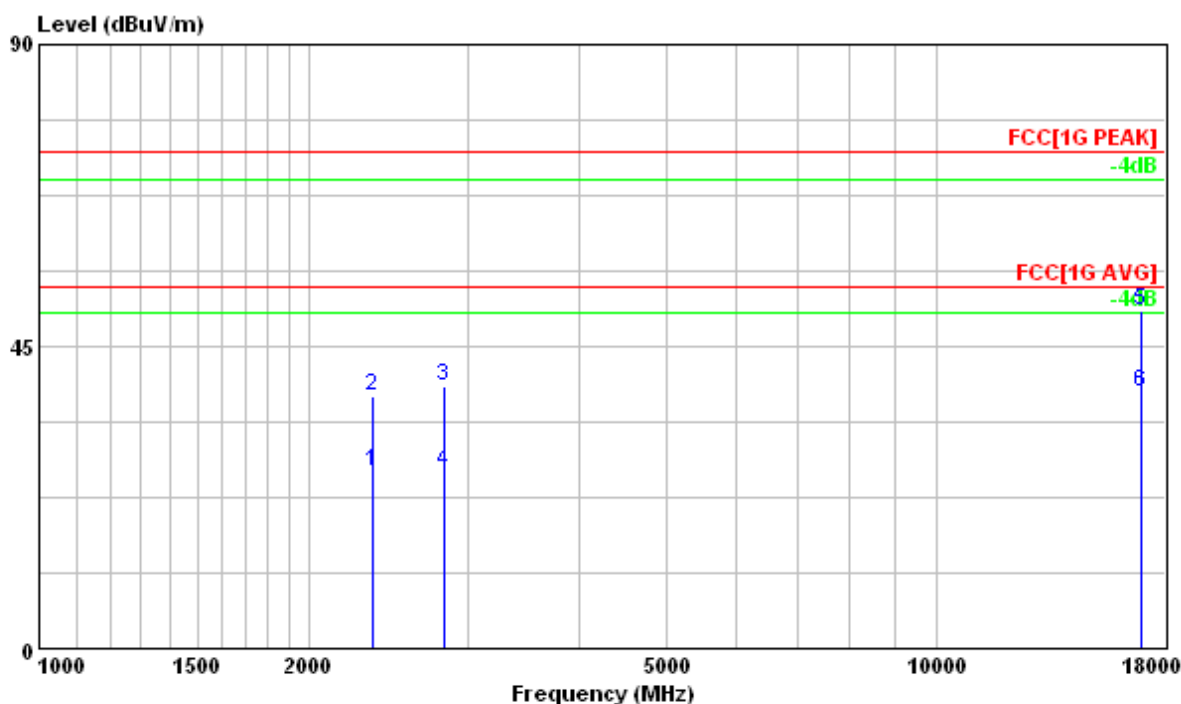

	Freq	Level	Read Level	Factor	Limit Line	Over Limit	Ant Pos	Table Pos	Pol/Phase	Remark
	MHz	dBuV/m	dBuV	dB/m	dBuV/m	dB	cm	deg		
1	2350.000	26.28	62.39	-36.11	54.00	-27.72	100	12	VERTICAL	Average
2	2350.000	37.73	73.84	-36.11	74.00	-36.27	100	12	VERTICAL	Peak
3	2824.000	39.16	74.52	-35.36	74.00	-34.84	100	358	VERTICAL	Peak
4	2824.000	26.38	61.74	-35.36	54.00	-27.62	100	358	VERTICAL	Average
5	16951.820	50.29	58.78	-8.49	74.00	-23.71	101	153	VERTICAL	Peak
6	16951.820	38.25	46.74	-8.49	54.00	-15.75	101	153	VERTICAL	Average

Note:

1. Emission Level = reading value + correction factor.
2. Correction factor = cable loss + antenna factor – gain of pre-amplifier.

No signal can be detected from 18GHz to 25GHz, so the graphs are omitted above 18GHz.

4 Antenna Requirement

Result: Pass

4.1 Applied standard

An intentional radiator shall be designed to ensure that no antenna other than that furnished by the responsible party shall be used with the device. The use of a permanently attached antenna or of an antenna that uses a unique coupling to the intentional radiator shall be considered sufficient to comply with the provisions of this Section. The manufacturer may design the unit so that a broken antenna can be replaced by the user, but the use of a standard antenna jack or electrical connector is prohibited. This requirement does not apply to carrier current devices or to devices operated under the provisions of Sections 15.211, 15.213, 15.217, 15.219, or 15.221. Further, this requirement does not apply to intentional radiators that must be professionally installed, such as perimeter protection systems and some field disturbance sensors, or to other intentional radiators which, in accordance with Section 15.31(d), must be measured at the installation site. However, the installer shall be responsible for ensuring that the proper antenna is employed so that the limits in this Part are not exceeded.

4.2 Antenna Information

The antenna uses unique connector

4.3 Result

Pass