

TEST REPORT

Test report no.: 1-4025/11-01-05-A



Testing laboratory

CETECOM ICT Services GmbH
 Untertuerkheimer Strasse 6 – 10
 66117 Saarbruecken / Germany
 Phone: + 49 681 5 98 - 0
 Fax: + 49 681 5 98 - 9075
 Internet: <http://www.cetecom.com>
 e-mail: ict@cetecom.com

Accredited Testing Laboratory:

The testing laboratory (area of testing) is accredited according to DIN EN ISO/IEC 17025 (2005) by the Deutsche Akkreditierungsstelle GmbH (DAkkS). The accreditation is valid for the scope of testing procedures as stated in the accreditation certificate with the registration number: D-PL-12076-01-01. Area of Testing: Radio/Satellite Communications

Applicant

FLIR Systems AB
 Rinkebyvägen 19
 SE-182 11 Danderyd / SWEDEN
 Phone: +46 (0) 8 753 27 50
 Fax: -/-
 Contact: Göran Skedung
 e-mail: goran.skedung@flir.se
 Phone: +46 87 53 27 59

Manufacturer

FLIR Systems AB
 Rinkebyvägen 19
 SE-182 11 Danderyd / SWEDEN

Test standard/s

47 CFR Part 15 Title 47 of the Code of Federal Regulations; Chapter I
 Part 15 - Radio frequency devices

RSS - 210 Issue 8 Spectrum Management and Telecommunications - Radio Standards Specification
 Low-power Licence-exempt Radiocommunication Devices (All Frequency Bands):
 Category I Equipment

For further applied test standards please refer to section 3 of this test report.

Test Item

Kind of test item: Camera
Model name: T62101
FCC ID: ZLV-FLIRT62101
IC: 5306A-FLIRT62101
Frequency: ISM band 2400 MHz to 2483.5 MHz
 (lowest channel 01 – 2412 MHz,
 highest channel 11 – 2462 MHz)
Technology tested: WLAN
Antenna: Integrated antenna
Power Supply: 7.4 V DC by Li-Ion battery
Temperature Range: -20°C to +55 °C



This test report is electronically signed and valid without handwriting signature. For verification of the electronic signatures, the public keys can be requested at the testing laboratory.

Test report authorised:

[Signature box]

Stefan Bös
 Senior Testing Manager

Test performed:

[Signature box]

Andreas Luckenbill

1 Table of contents

1 Table of contents2

2 General information3

 2.1 Notes and disclaimer3

 2.2 Application details.....3

3 Test standard/s3

4 Test environment.....4

5 Test item4

6 Test laboratories sub-contracted4

7 Summary of measurement results5

8 RF measurements6

 8.1 Description of test setup6

 8.1.1 Radiated measurements.....6

 8.1.2 Conducted measurements.....7

 8.2 Additional comments7

 8.3 RSP100 test report cover sheet / performance test data8

9 Measurement results.....9

 9.1 Output power verification (conducted)9

 9.2 Antenna gain10

 9.3 Maximum output power11

 9.4 Power spectral density13

 9.5 Spectrum bandwidth – 6 dB / 75 % power bandwidth (EBW)14

 9.6 Spectrum bandwidth – 20 dB / 99 % power bandwidth18

 9.7 Band edge compliance conducted22

 9.8 Band edge compliance radiated25

 9.9 TX spurious emissions conducted30

 9.10 TX spurious emissions radiated42

 9.11 RX spurious emissions radiated62

 9.12 Spurious emissions radiated < 30 MHz66

 9.13 Spurious emissions conducted < 30 MHz.....69

10 Test equipment and ancillaries used for tests73

11 Observations73

Annex A Photographs of the test setup74

Annex B External photographs of the EUT78

Annex C Internal photographs of the EUT83

Annex D Document history100

Annex E Further information.....100

Annex F Accreditation Certificate101

2 General information

2.1 Notes and disclaimer

The test results of this test report relate exclusively to the test item specified in this test report. CETECOM ICT Services GmbH does not assume responsibility for any conclusions and generalizations drawn from the test results with regard to other specimens or samples of the type of the equipment represented by the test item.

The test report may only be reproduced or published in full. Reproduction or publication of extracts from the report requires the prior written approval of CETECOM ICT Services GmbH.

The testing service provided by CETECOM ICT Services GmbH has been rendered under the current "General Terms and Conditions for CETECOM ICT Services GmbH".

CETECOM ICT Services GmbH will not be liable for any loss or damage resulting from false, inaccurate, inappropriate or incomplete product information provided by the customer.

Under no circumstances does the CETECOM ICT Services GmbH test report include any endorsement or warranty regarding the functionality, quality or performance of any other product or service provided.

Under no circumstances does the CETECOM ICT Services GmbH test report include or imply any product or service warranties from CETECOM ICT Services GmbH, including, without limitation, any implied warranties of merchantability, fitness for purpose, or non-infringement, all of which are expressly disclaimed by CETECOM ICT Services GmbH.

All rights and remedies regarding vendor's products and services for which CETECOM ICT Services GmbH has prepared this test report shall be provided by the party offering such products or services and not by CETECOM ICT Services GmbH.

In no case this test report can be considered as a Letter of Approval.

This test report is electronically signed and valid without handwritten signature. For verification of the electronic signatures, the public keys can be requested at the testing laboratory.

2.2 Application details

Date of receipt of order:	2012-03-05
Date of receipt of test item:	2012-03-07
Start of test:	2012-03-07
End of test:	2012-06-28
Person(s) present during the test:	-/-

3 Test standard/s

Test standard	Date	Test standard description
47 CFR Part 15	2010-10	Title 47 of the Code of Federal Regulations; Chapter I Part 15 - Radio frequency devices
RSS - 210 Issue 8	2010-12	Spectrum Management and Telecommunications - Radio Standards Specification Low-power Licence-exempt Radiocommunication Devices (All Frequency Bands): Category I Equipment

4 Test environment

Temperature:	T_{nom}	+22 °C during room temperature tests
	T_{max}	+55 °C during high temperature tests
	T_{min}	-20 °C during low temperature tests
Relative humidity content:		52 %
Barometric pressure:		not relevant for this kind of testing
Power supply:	V_{nom}	7.4 V DC by Li-Ion battery
	V_{max}	8.4 V
	V_{min}	6.9 V

5 Test item

Kind of test item	:	Camera
Type identification	:	T62101
S/N serial number	:	Radiated unit: 62000140 Conducted unit: 62000142
HW hardware status	:	Please take a look at the PCB!
SW software status	:	1.9.5
Frequency band [MHz]	:	ISM band 2400 MHz to 2483.5 MHz (lowest channel 01 – 2412 MHz, highest channel 11 – 2462 MHz)
Type of radio transmission	:	DSSS & OFDM
Use of frequency spectrum	:	
Channel access method	:	FDMA
Type of modulation	:	BPSK, QPSK, 16 – QAM & 64 – QAM
Number of channels	:	11
Antenna	:	Integrated antenna
Power supply	:	7.4 V DC by Li-Ion battery
Temperature range	:	-20°C to +55 °C

6 Test laboratories sub-contracted

None

7 Summary of measurement results

- No deviations from the technical specifications were ascertained
- There were deviations from the technical specifications ascertained

TC Identifier	Description	Verdict	Date	Remark
RF-Testing	CFR Part 15 RSS 210, Issue 8	Passed	2012-11-06	-/-

Test specification clause	Test case	Temperature conditions	Power source voltages	Mode	Pass	Fail	NA	NP	Remark
§15.247(b)(4) RSS 210 / A8.4(2)	Antenna gain	Nominal	Nominal	DSSS	<input checked="" type="checkbox"/>	<input type="checkbox"/>	<input type="checkbox"/>	<input type="checkbox"/>	complies
§15.247(e) RSS 210 / A8.2(b)	Power spectral density	Nominal	Nominal	DSSS/ OFDM g	<input checked="" type="checkbox"/> <input checked="" type="checkbox"/>	<input type="checkbox"/> <input type="checkbox"/>	<input type="checkbox"/> <input type="checkbox"/>	<input type="checkbox"/> <input type="checkbox"/>	complies
§15.247(a)(2) RSS 210 / A8.2(a)	Spectrum bandwidth - 6dB bandwidth	Nominal	Nominal	DSSS/ OFDM g	<input checked="" type="checkbox"/> <input checked="" type="checkbox"/>	<input type="checkbox"/> <input type="checkbox"/>	<input type="checkbox"/> <input type="checkbox"/>	<input type="checkbox"/> <input type="checkbox"/>	complies
§15.247(a)(2) RSS 210 / A8.2(a)	Spectrum bandwidth - 20dB bandwidth	Nominal	Nominal	DSSS/ OFDM g	<input checked="" type="checkbox"/> <input checked="" type="checkbox"/>	<input type="checkbox"/> <input type="checkbox"/>	<input type="checkbox"/> <input type="checkbox"/>	<input type="checkbox"/> <input type="checkbox"/>	complies
§15.247(b)(3) RSS-210 / A8.4(4)	Maximum output power	Nominal	Nominal	DSSS/ OFDM g	<input checked="" type="checkbox"/> <input checked="" type="checkbox"/>	<input type="checkbox"/> <input type="checkbox"/>	<input type="checkbox"/> <input type="checkbox"/>	<input type="checkbox"/> <input type="checkbox"/>	complies
§15.247(d) RSS-210 / A8.5	Band edge compliance conducted	Nominal	Nominal	DSSS/ OFDM g	<input checked="" type="checkbox"/> <input checked="" type="checkbox"/>	<input type="checkbox"/> <input type="checkbox"/>	<input type="checkbox"/> <input type="checkbox"/>	<input type="checkbox"/> <input type="checkbox"/>	complies
§15.205 RSS-210 / A8.5	Band edge compliance radiated	Nominal	Nominal	DSSS/ OFDM g	<input checked="" type="checkbox"/> <input checked="" type="checkbox"/>	<input type="checkbox"/> <input type="checkbox"/>	<input type="checkbox"/> <input type="checkbox"/>	<input type="checkbox"/> <input type="checkbox"/>	complies
§15.247(d) RSS-210 / A8.5	TX spurious emissions conducted	Nominal	Nominal	DSSS/ OFDM g	<input checked="" type="checkbox"/> <input checked="" type="checkbox"/>	<input type="checkbox"/> <input type="checkbox"/>	<input type="checkbox"/> <input type="checkbox"/>	<input type="checkbox"/> <input type="checkbox"/>	complies
§15.247(d) RSS-210 / A8.5	TX spurious emissions radiated	Nominal	Nominal	DSSS/ OFDM g	<input checked="" type="checkbox"/> <input checked="" type="checkbox"/>	<input type="checkbox"/> <input type="checkbox"/>	<input type="checkbox"/> <input type="checkbox"/>	<input type="checkbox"/> <input type="checkbox"/>	complies
§15.109 RSS-Gen.	RX spurious emissions radiated	Nominal	Nominal	Idle / RX mode	<input checked="" type="checkbox"/>	<input type="checkbox"/>	<input type="checkbox"/>	<input type="checkbox"/>	complies
§15.209(a) RSS-Gen	TX spurious emissions radiated < 30 MHz	Nominal	Nominal	DSSS / OFDM g Idle / RX mode	<input checked="" type="checkbox"/> <input checked="" type="checkbox"/>	<input type="checkbox"/> <input type="checkbox"/>	<input type="checkbox"/> <input type="checkbox"/>	<input type="checkbox"/> <input type="checkbox"/>	complies
§15.107(a)	Conducted emissions < 30 MHz	Nominal	Nominal	DSSS / OFDM g Idle / RX mode	<input checked="" type="checkbox"/> <input checked="" type="checkbox"/>	<input type="checkbox"/> <input type="checkbox"/>	<input type="checkbox"/> <input type="checkbox"/>	<input type="checkbox"/> <input type="checkbox"/>	complies

Note: NA = Not Applicable; NP = Not Performed

8 RF measurements

8.1 Description of test setup

8.1.1 Radiated measurements

The radiated measurements are performed in vertical and horizontal plane in the frequency range from 9 kHz to 25 GHz in semi-anechoic chambers. The EUT is positioned on a non-conductive support with a height of 0.80 m above a conductive ground plane that covers the whole chamber. The receiving antennas are confirmed with specifications ANSI C63.2-1996 clause 15 and ANSI C63.4-2009 clause 4.1.5. These antennas can be moved over the height range between 1.0 m and 4.0 m in order to search for maximum field strength emitted from EUT. The measurement distances between EUT and receiving antennas are indicated in the test setups for the various frequency ranges. For each measurement, the EUT is rotated in all three axes until the maximum field strength is received. The wanted and unwanted emissions are received by spectrum analysers where the detector modes and resolution bandwidths over various frequency ranges are set according to requirement ANSI C63-4-2009 clause 4.2.

Antennas are confirmed with ANSI C63.2-1996 item 15.

Semi anechoic chamber

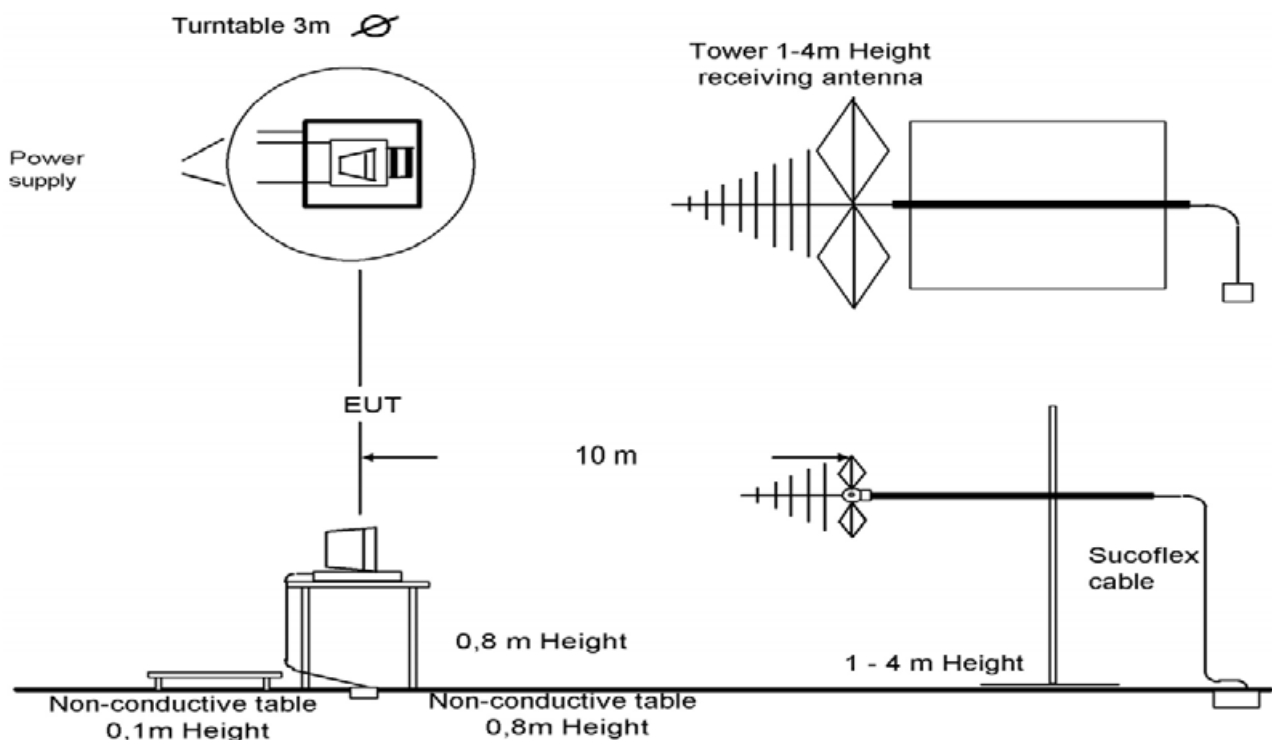

Picture 1: Diagram radiated measurements

9 kHz - 30 MHz:	active loop antenna
30 MHz – 1 GHz:	tri-log antenna
> 1 GHz:	horn antenna

The EUT is powered by an external power supply with nominal voltage. The signalling is performed from outside the chamber with a signalling unit (CMU200 or other) by air link using signalling antenna.

8.1.2 Conducted measurements

The EUT's RF signal is coupled out by the antenna connector which is supplied by the manufacturer. The signal is first 10dB attenuated before it is power divided (~6dB loss per branch). One of the signal paths is connected to the communication base Station (CMU200 or other), the other one is connected to the spectrum analyzer. The specific losses for both signal paths are first checked within a calibration. The measurement readings on the signalling unit/spectrum analyzer are corrected by the specific test set-up loss. The attenuator, power divider, signalling unit and the spectrum analyzer are impedance matched on 50 Ohm.

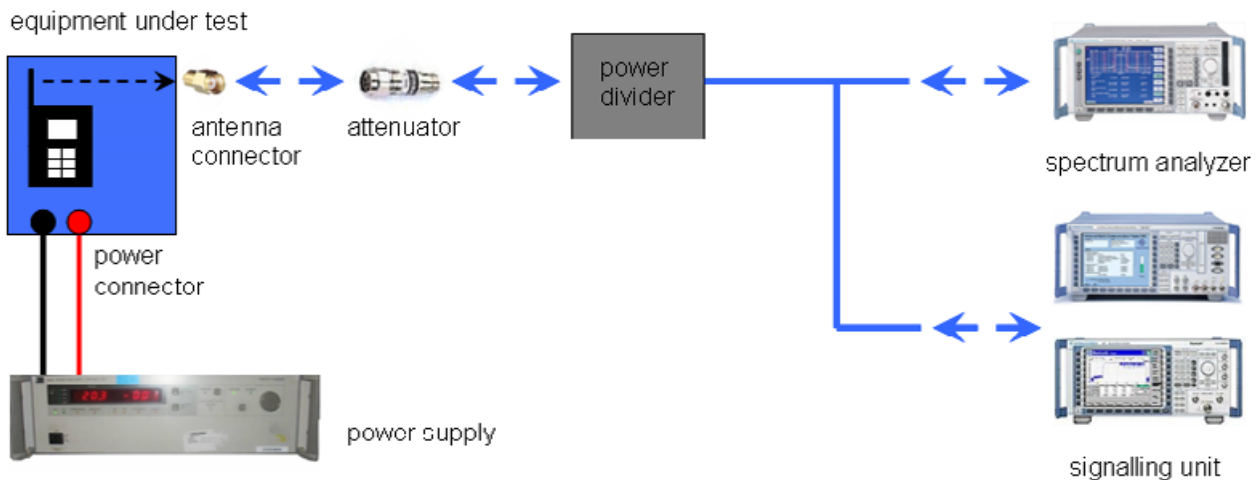

Picture 2: Diagram conducted measurements

8.2 Additional comments

Reference documents: None

Special test descriptions: None

Configuration descriptions: None

- Test mode:
- No test mode available.
Iperf was used to ping another device with the largest support packet size
 - Special software is used.
EUT is transmitting pseudo random data by itself

8.3 RSP100 test report cover sheet / performance test data

Test report number	:	1-4025/11-01-05-A
Equipment model number	:	T62101
Certification number	:	5306A-FLIRT62101
Manufacturer (complete address)	:	FLIR Systems AB Rinkebyvägen 19 SE-182 11 Danderyd / SWEDEN
Tested to radio standards specification no.	:	RSS 210, Issue 8
Open area test site IC No.	:	IC 3462C-1
Frequency range	:	ISM band 2400 MHz to 2483.5 MHz (lowest channel 01 – 2412 MHz, highest channel 11 – 2462 MHz)
RF-power [W] (max.)	:	Conducted output power: 65.01 mW (DSSS / b – mode) 42.85 mW (OFDM / g – mode) Radiated output power: 67.61 mW (DSSS / b – mode) 42.85 mW (OFDM / g – mode)
Occupied bandwidth (99%-BW)	:	DSSS / b – mode: 13.89 MHz OFDM / g – mode: 16.49 MHz
Type of modulation	:	DSSS & OFDM technology with BPSK, QPSK, 16 – and 64 QAM modulation.
Emission designator (TRC-43)	:	13M9G1D (DSSS / b – mode) 16M5G7D (OFDM / g – mode)
Antenna information	:	Integrated antenna
Transmitter spurious (worst case) [dB μ V/m @ 3m]:		46 @ 12.7 GHz (noise floor)
Receiver spurious (worst case) [dB μ V/m @ 3m]:		46 @ 12.7 GHz (noise floor)

ATTESTATION:

DECLARATION OF COMPLIANCE:

I attest that the testing was performed or supervised by me; that the test measurements were made in accordance with the above-mentioned Industry Canada standard(s); and that the equipment identified in this application has been subjected to all the applicable test conditions specified in the Industry Canada standards and all of the requirements of the standard have been met.

Laboratory manager:

2012-11-06

Andreas Luckenbill



Date

Name

Signature

9 Measurement results

9.1 Output power verification (conducted)

Description:

Measurement of the maximum output power conducted. This measurement is performed only at the middle channel in both modes and all data rates to determine the data rate per mode which results in the highest output power. This mode will be selected for all further measurements.

Used measurement option: 5.2.1.1 PK1

Measurement:

Measurement parameter	
Detector:	Peak
Sweep time:	Auto
Resolution bandwidth:	> EBW
Video bandwidth:	≥ 3 x RBW (or the maximum of the analyzer)
Span:	Zero span
Trace-Mode:	Max hold (allow trace to fully stabilize)

Results:

DSSS / b – mode Data Rate [MBit/s]	Maximum Output Power Conducted [dBm]			
	1	2	5.5	11
Ch 6 - 2437 MHz	18.09	17.67	18.03	18.04
Measurement uncertainty	± 0.5 dB			

OFDM / g – mode Data Rate [MBit/s]	Maximum Output Power Conducted [dBm]							
	6	9	12	18	24	36	48	54
Ch 6 - 2437 MHz	15.97	16.24	15.58	16.32	15.66	15.81	15.97	13.07
Measurement uncertainty	± 0.5 dB							

Result: Selected data rate for all measurements:

DSSS / b – mode:
OFDM / g – mode:

1 MBit/s
18 MBit/s

9.2 Antenna gain

Measurement:

The antenna gain of the complete system is calculated by the difference of radiated power in EIRP and the conducted power of the module. For normal WLAN devices, the DSSS mode is used.

Measurement parameters:

Measurement parameter	
Detector:	Peak
Sweep time:	Auto
Resolution bandwidth:	3 MHz
Video bandwidth:	3 MHz
Trace-Mode:	Max hold

Limits:

FCC	IC
Antenna Gain	
6 dBi	

Results:

T _{nom}	V _{nom}	lowest channel 2412 MHz	middle channel 2437 MHz	highest channel 2462 MHz
Conducted power [dBm] Measured with DSSS modulation		12.13	12.14	12.35
Radiated power [dBm] Measured with DSSS modulation		12.30	11.26	12.24
Gain [dBi] Calculated		0.17	-0.88	-0.11
Measurement uncertainty			± 1.5 dB (cond.) / ± 3 dB (rad.)	

Result: **Passed**

9.3 Maximum output power

Description:

Measurement of the maximum output power conducted and radiated. The measurements are performed using the data rate producing the highest conducted output power. The determination of these data rates was performed at the beginning of the tests.

Used measurement option: 5.2.1.1 PK1

Measurement:

Measurement parameter	
Detector:	Peak
Sweep time:	Auto
Resolution bandwidth:	> EBW
Video bandwidth:	≥ 3 x RBW (or the maximum of the analyzer)
Span:	Zero span
Trace-Mode:	Max hold (allow trace to fully stabilize)

Limits:

FCC	IC
Maximum Output Power	
Conducted: 1.0 W – Antenna Gain max. 6 dBi	

Results: DSSS / b – mode

DSSS / b – mode Frequency	Maximum Output Power [dBm]		
	2412 MHz	2437 MHz	2462 MHz
Peak Output Power Conducted	18.13	18.09	18.03
Output Power Radiated – EIRP*)	18.30	17.21	17.92
Measurement uncertainty	± 1.5 dB (cond.) / ± 3 dB (rad.)		

*) calculated with Antenna gain

Result: Passed

Results: OFDM / g – mode

OFDM / g – mode Frequency	Maximum Output Power [dBm]		
	2412 MHz	2437 MHz	2462 MHz
Peak Output Power Conducted	16.14	16.32	15.32
Output Power Radiated – EIRP*)	16.31	15.44	15.21
Measurement uncertainty	± 1.5 dB (cond.) / ± 3 dB (rad.)		

*) calculated with Antenna gain

Result: Passed

9.4 Power spectral density

Description:

Measurement of the power spectral density of a digital modulated system. The measurement is repeated for both modulations at the lowest, middle and highest channel.

Used measurement option: 5.3.1 PKPSD

Measurement:

Measurement parameter	
Detector:	Peak
Sweep time:	Auto
Resolution bandwidth:	100 kHz
Video bandwidth:	≥ 300 kHz
Span:	5 - 30 % greater than the EBW
Trace-Mode:	Max hold (allow trace to fully stabilize)
Bandwidth correction:	$10 \log (3\text{kHz} / 100\text{kHz}) = -15.2 \text{ dB}$

Limits:

FCC	IC
Power Spectral Density	
8 dBm (conducted)	

Results:

Modulation Frequency	Power Spectral density [dBm]		
	2412 MHz	2437 MHz	2462 MHz
DSSS / b – mode measured value (100 kHz)	2.86	2.75	2.72
DSSS / b – mode re-calculated value (to 3 kHz)	-12.34	-12.45	-12.48
OFDM / g – mode measured value (100 kHz)	-7.35	-6.13	-7.05
OFDM / g – mode re-calculated value (to 3 kHz)	-22.55	-21.33	-22.25
Measurement uncertainty	± 1.5 dB		

Result: Passed

9.5 Spectrum bandwidth – 6 dB / 75 % power bandwidth (EBW)

Description:

Measurement of the 6 dB / 75 % power bandwidth of the modulated signal.

Used measurement option: 5.1.2.

Measurement:

Measurement parameter	
Detector:	Peak
Sweep time:	Auto
Resolution bandwidth:	1 - 5% of emission bandwidth
Video bandwidth:	≥ 3 x RBW
Span:	> complete emission
Trace-Mode:	Max hold (allow trace to stabilize)
Measurement option:	Automatic bandwidth measurement (75% power)

Limits:

FCC	IC
Spectrum Bandwidth – 6 dB / 75 % power bandwidth (EBW)	
Systems using digital modulation techniques may operate in the 2400–2483.5 MHz band. The minimum 6 dB bandwidth shall be at least 500 kHz.	

Results:

Modulation Frequency	6 dB / 75 % power bandwidth [MHz] (EBW)		
	2412 MHz	2437 MHz	2462 MHz
DSSS / b – mode	7.21	7.21	7.21
OFDM / g – mode	12.55	12.50	12.55
Measurement uncertainty	± RBW		

Result: Passed

Plots: DSSS / b – mode

Plot 1: TX mode, lowest channel

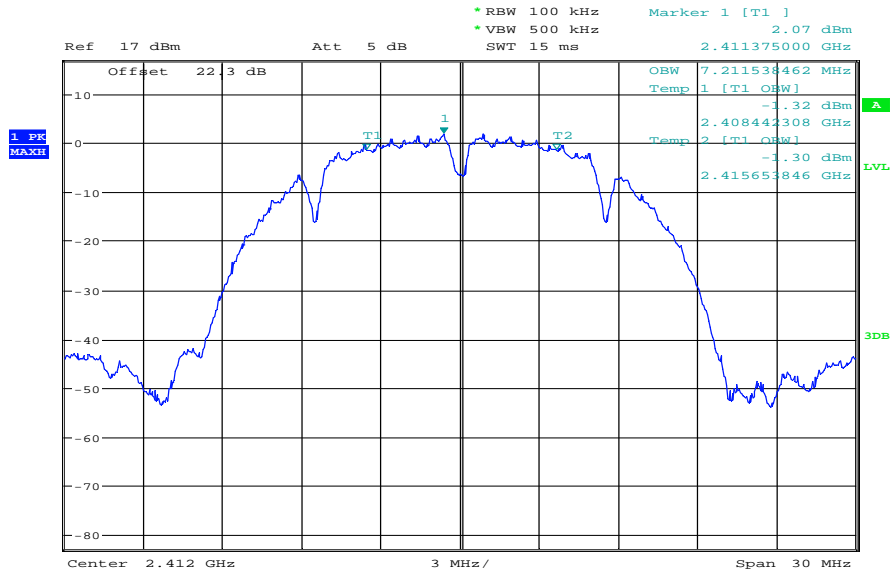

Date: 5.MAR.2012 15:14:45

Plot 2: TX mode, middle channel

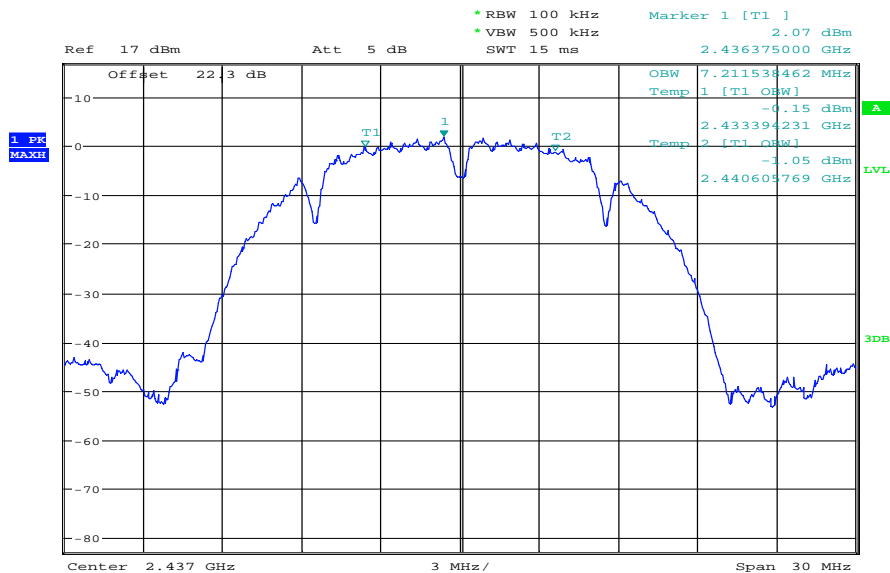

Date: 5.MAR.2012 15:14:16

Plot 3: TX mode, highest channel

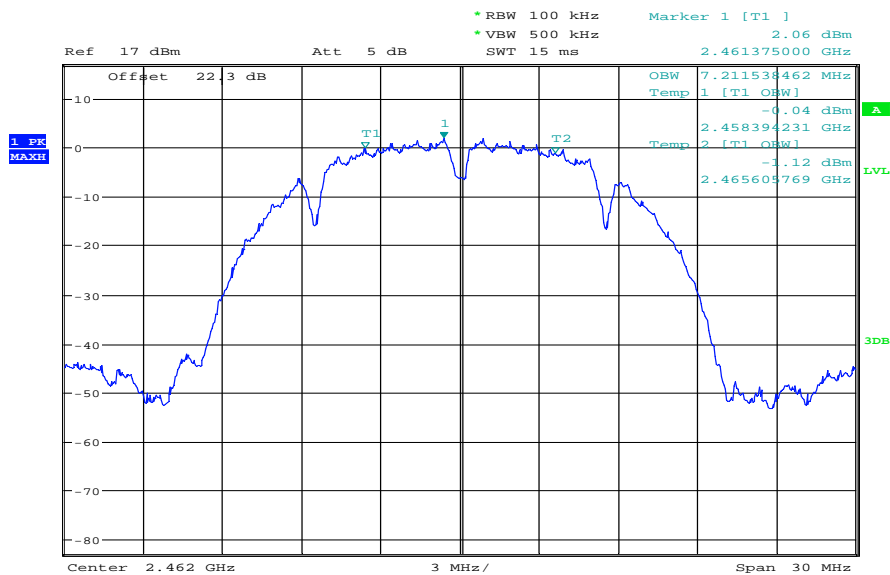

Date: 5.MAR.2012 15:12:47

Plots: OFDM / g – mode

Plot 1: TX mode, lowest channel

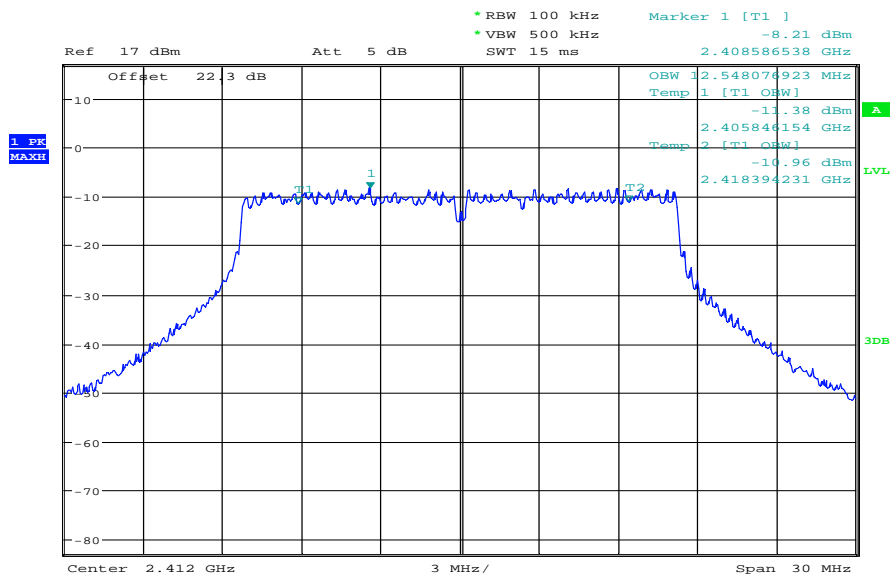

Date: 5.MAR.2012 15:09:03

Plot 2: TX mode, middle channel

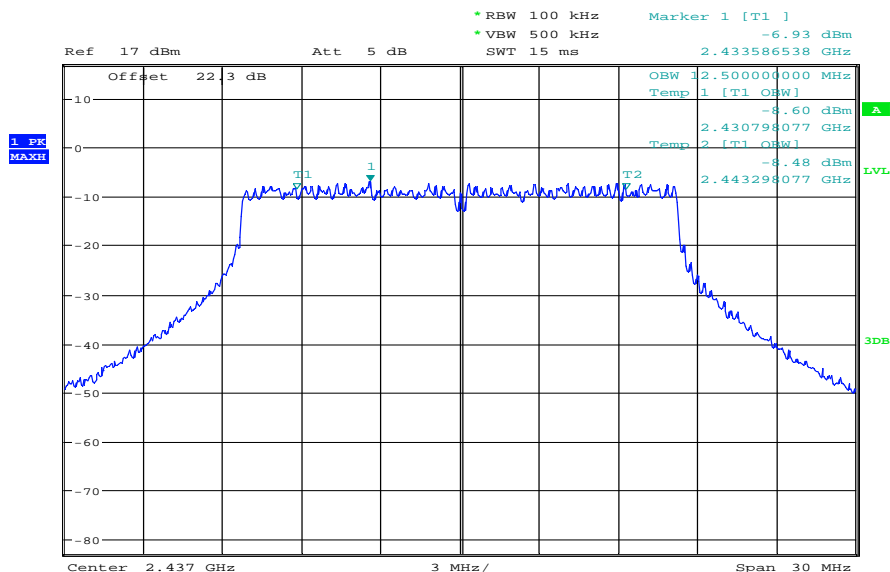

Date: 5.MAR.2012 15:09:39

Plot 3: TX mode, highest channel

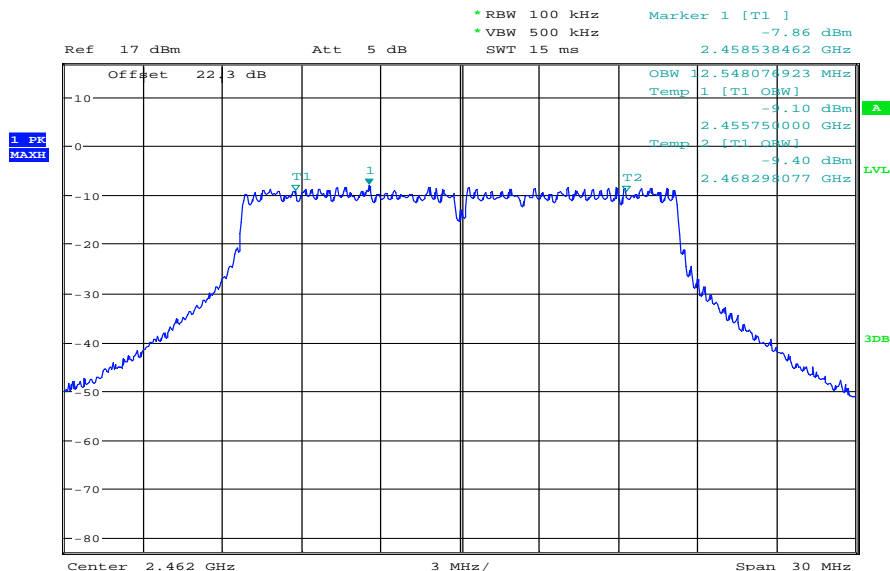

Date: 5.MAR.2012 15:10:52

9.6 Spectrum bandwidth – 20 dB / 99 % power bandwidth

Description:

Measurement of the 20 dB / 99% power bandwidth of the modulated signal.

Used measurement option: 5.1.2.

Measurement:

Measurement parameter	
Detector:	Peak
Sweep time:	Auto
Resolution bandwidth:	1 - 5% of emission bandwidth
Video bandwidth:	≥ 3 x RBW
Span:	> complete emission
Trace-Mode:	Max hold (allow trace to stabilize)
Measurement option:	Automatic bandwidth measurement (99% power)

Limits:

FCC	IC
Spectrum Bandwidth – 20 dB / 99 % power bandwidth	
Systems using digital modulation techniques may operate in the 2400–2483.5 MHz band. The minimum 6 dB bandwidth shall be at least 500 kHz.	

Results:

Modulation Frequency	20 dB / 99 % power bandwidth [MHz]		
	2412 MHz	2437 MHz	2462 MHz
DSSS / b – mode	13.89	13.85	13.85
OFDM / g – mode	16.49	16.49	16.49
Measurement uncertainty	± RBW		

Result: Passed

Plots: DSSS / b – mode

Plot 1: TX mode, lowest channel

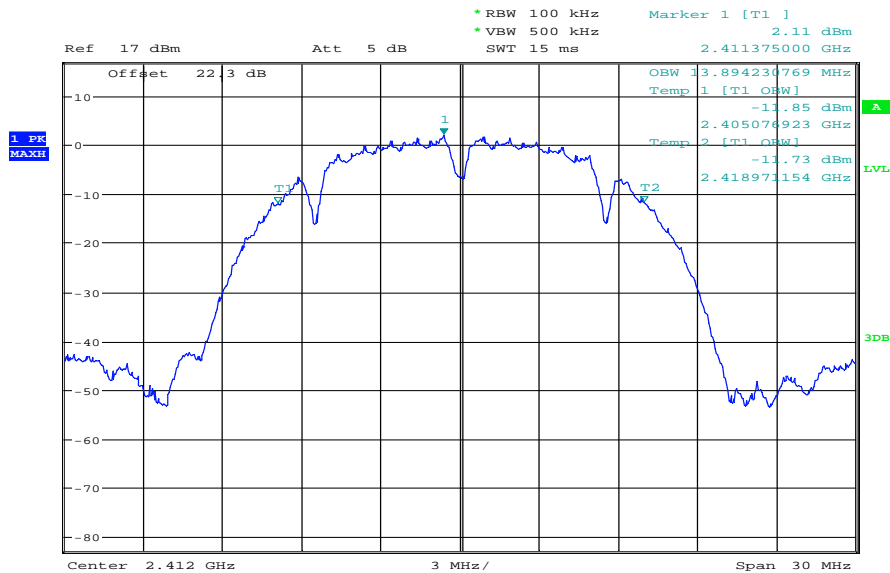

Date: 5.MAR.2012 15:15:10

Plot 2: TX mode, middle channel

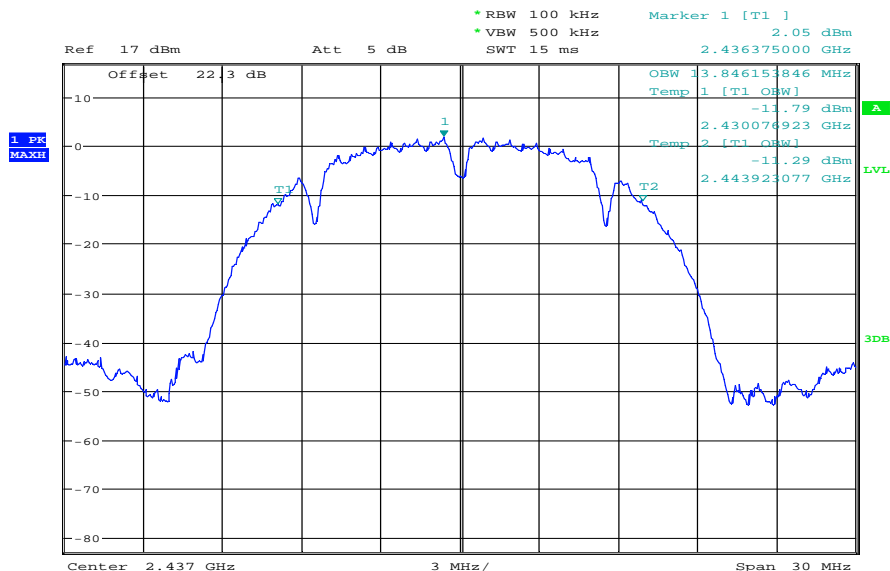

Date: 5.MAR.2012 15:13:52

Plot 3: TX mode, highest channel

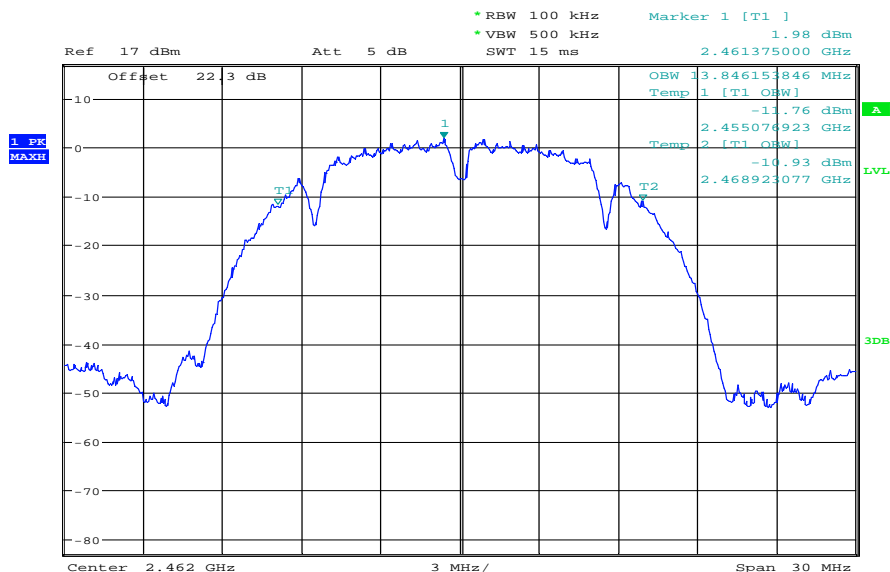

Date: 5.MAR.2012 15:13:15

Plots: OFDM / g – mode

Plot 1: TX mode, lowest channel

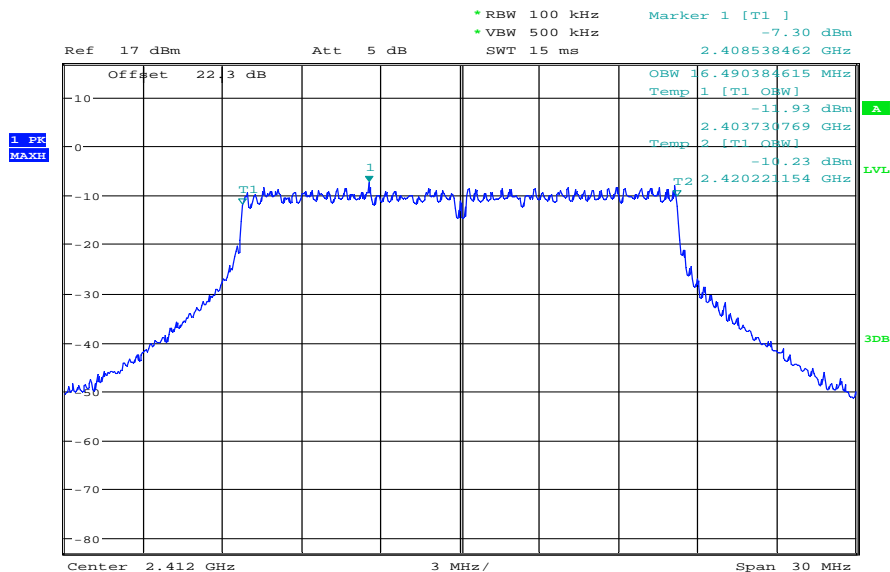

Date: 5.MAR.2012 15:08:31

Plot 2: TX mode, middle channel

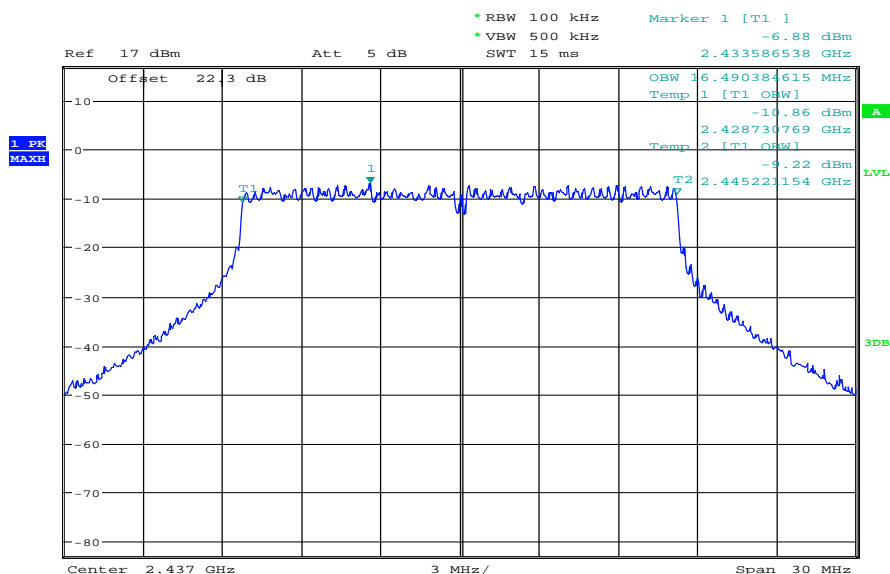

Date: 5.MAR.2012 15:09:58

Plot 3: TX mode, highest channel

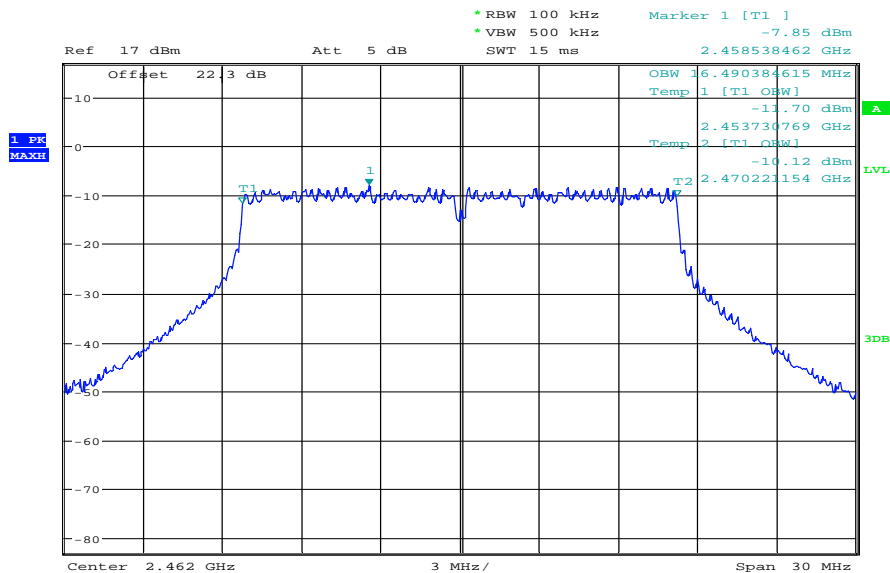

Date: 5.MAR.2012 15:10:25

9.7 Band edge compliance conducted

Description:

Measurement of the conducted band edge compliance. EUT is measured at the lower and upper band edge in both modes.

Measurement:

Measurement parameter	
Detector:	Peak
Sweep time:	Auto
Resolution bandwidth:	100 kHz
Video bandwidth:	500 kHz
Span:	Lower Band Edge: 2300 – 2425 MHz Upper Band Edge: 2450 – 2500 MHz
Trace-Mode:	Max hold

Limits:

FCC	IC
Band Edge Compliance Conducted	
<p>In any 100 kHz bandwidth outside the frequency band in which the spread spectrum or digitally modulated intentional radiator is operating, the radio frequency power that is produced by the intentional radiator shall be at least 20 dB below that in the 100 kHz bandwidth within the band that contains the highest level of the desired power, based on either an RF conducted or a radiated measurement. Attenuation below the general limits specified in Section 15.209(a) is not required.</p>	

Results:

Scenario Modulation	Band Edge Compliance Conducted [dB]		
	DSSS / b – mode	OFDM / g – mode	-/-
Lower Band Edge – Channel 1	> 20 dB (see plot 1)	> 20 dB (see plot 3)	-/-
Upper Band Edge – Channel 11	> 20 dB (see plot 2)	> 20 dB (see plot 4)	-/-
Measurement uncertainty	± 1.5 dB		

Result: Passed

Plots: DSSS / b – mode

Plot 1: TX mode, lower band edge

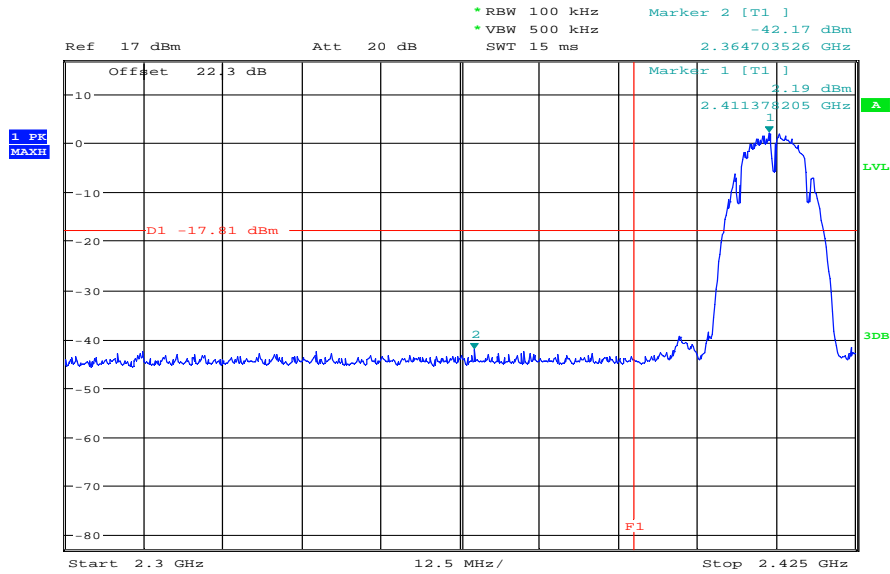

Date: 5.MAR.2012 15:17:55

Plot 2: TX mode, upper band edge

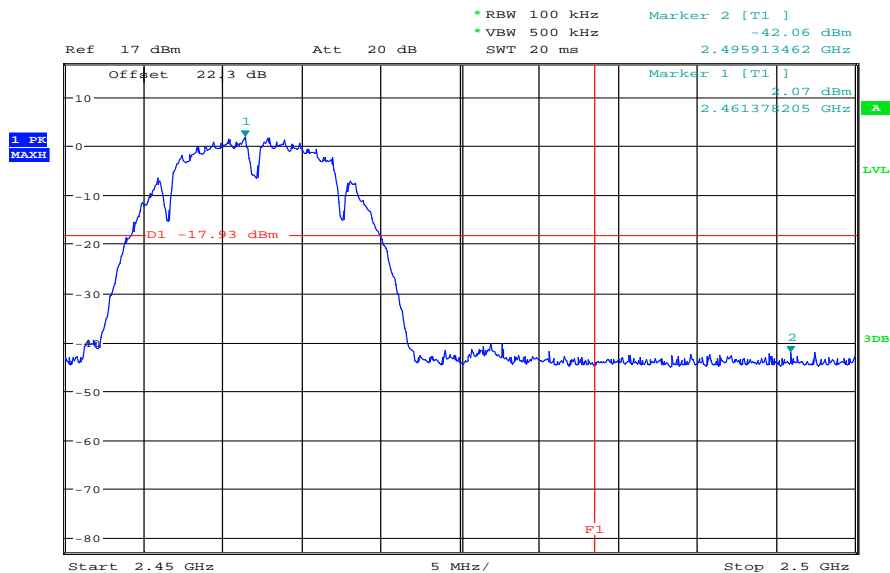

Date: 5.MAR.2012 15:24:07

Plots: OFDM / g – mode

Plot 1: TX mode, lower band edge

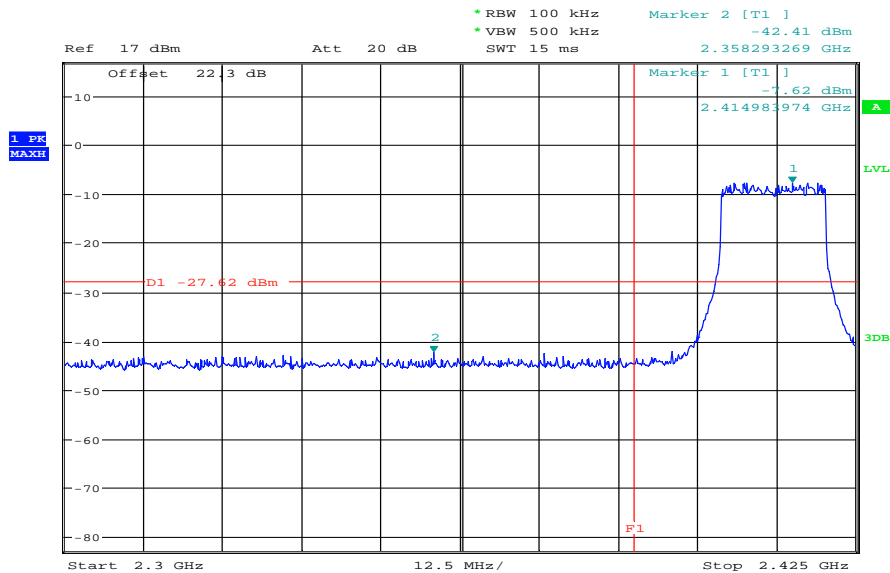

Date: 5.MAR.2012 15:19:58

Plot 2: TX mode, upper band edge

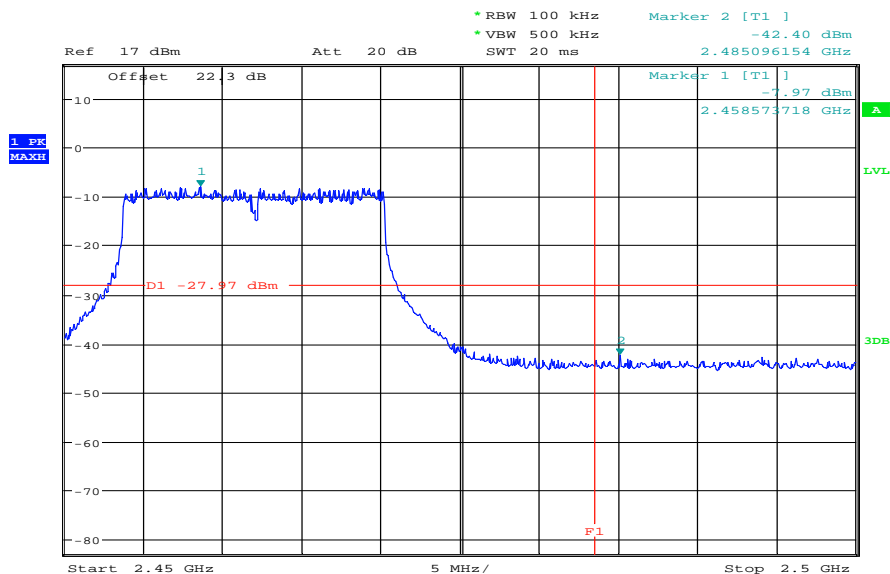

Date: 5.MAR.2012 15:21:46

9.8 Band edge compliance radiated

Description:

Measurement of the radiated band edge compliance. The EUT is turned in the position that results in the maximum level at the band edge. Then a sweep over the corresponding restricted band is performed. The EUT is set to channel 1 for the lower restricted band and to channel 11 for the upper restricted band. The measurement is repeated for all modulations. Measurement distance is 3m.

Measurement:

Measurement parameter	
Detector:	Peak
Sweep time:	Auto
Video bandwidth:	10 Hz
Resolution bandwidth:	1 MHz
Span:	Lower Band: 2300 – 2400 MHz Upper Band: 2480 – 2500 MHz
Trace-Mode:	Max Hold

Limits:

FCC	IC
Band Edge Compliance Radiated	
<p>In any 100 kHz bandwidth outside the frequency band in which the spread spectrum or digitally modulated intentional radiator is operating, the radio frequency power that is produced by the intentional radiator shall be at least 20 dB below that in the 100 kHz bandwidth within the band that contains the highest level of the desired power, based on either an RF conducted or a radiated measurement. Attenuation below the general limits specified in Section 15.209(a) is not required. In addition, radiated emissions which fall in the restricted bands, as defined in Section 15.205(a), must also comply with the radiated emission limits specified in Section 15.209(a) (see Section 5.205(c)).</p>	
54 dBµV/m AVG	

Results:

Scenario Modulation	Band Edge Compliance Conducted [dB]		
	DSSS / b – mode	OFDM / g – mode	-/-
Lower Band Edge – Channel 1	> 20 dB	> 20 dB	-/-
Upper Band Edge – Channel 11	> 20 dB	> 20 dB	-/-
Measurement uncertainty	± 3 dB		

Result: Passed

Plots: DSSS / b – mode

Plot 1: TX mode, lower band edge, vertical polarization

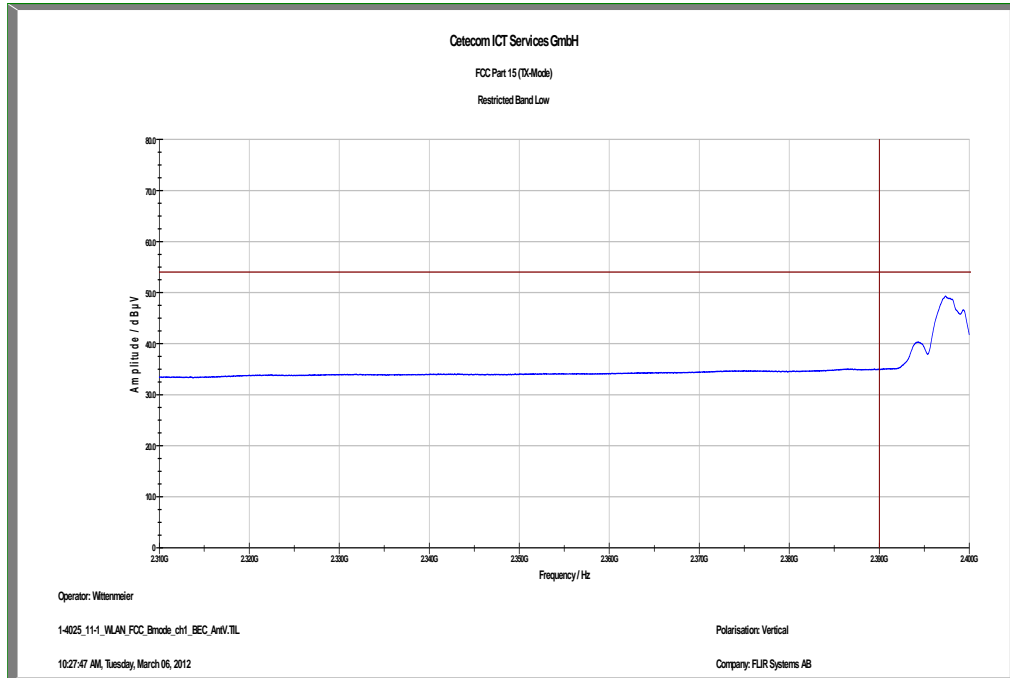

Plot 2: TX mode, upper band edge, vertical polarization

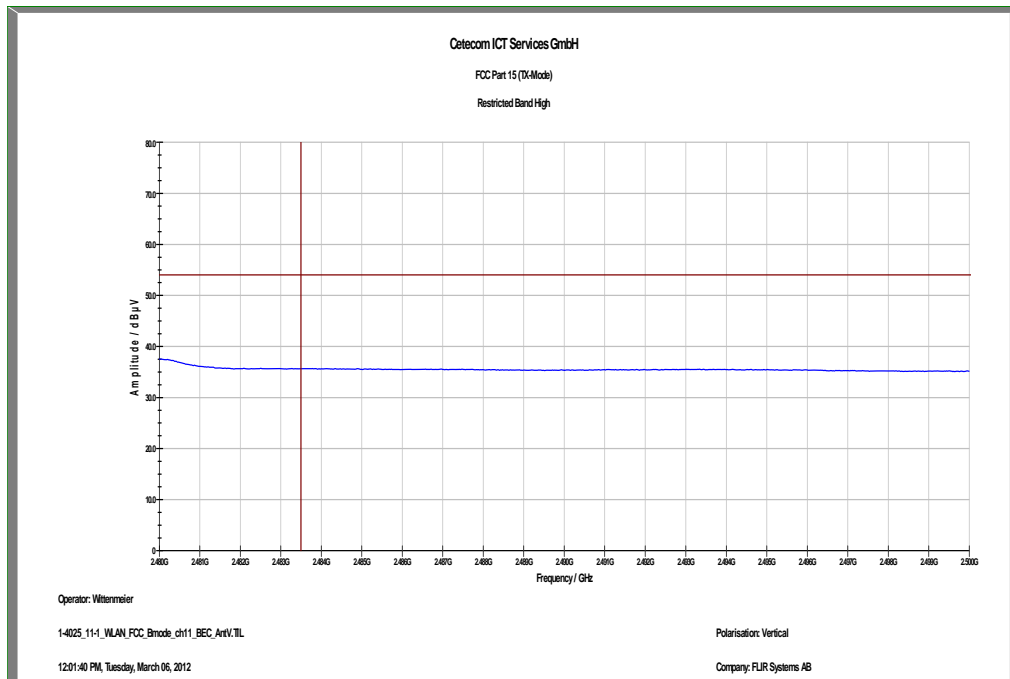

Plot 3: TX mode, lower band edge, horizontal polarization

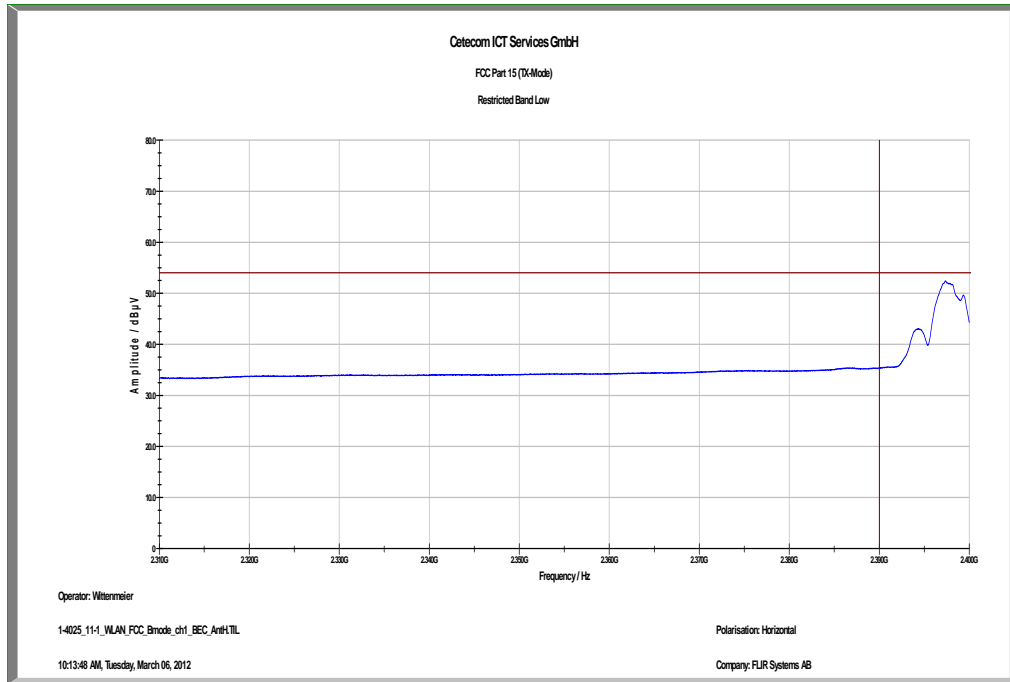

Plot 4: TX mode, upper band edge, horizontal polarization

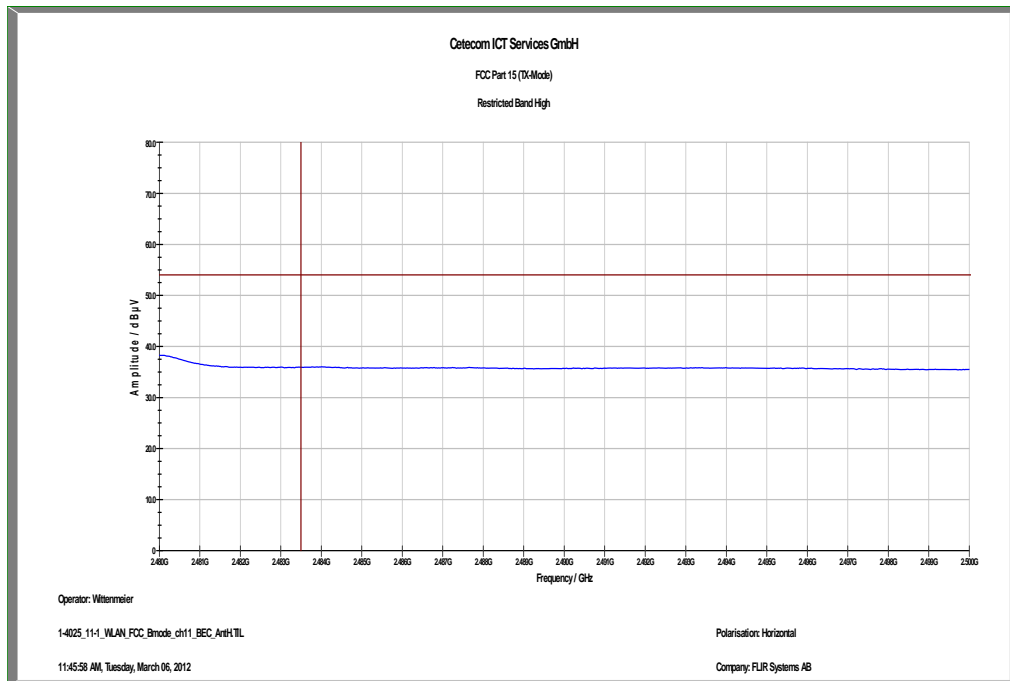

Plots: OFDM / g – mode

Plot 1: TX mode, lower band edge, vertical polarization

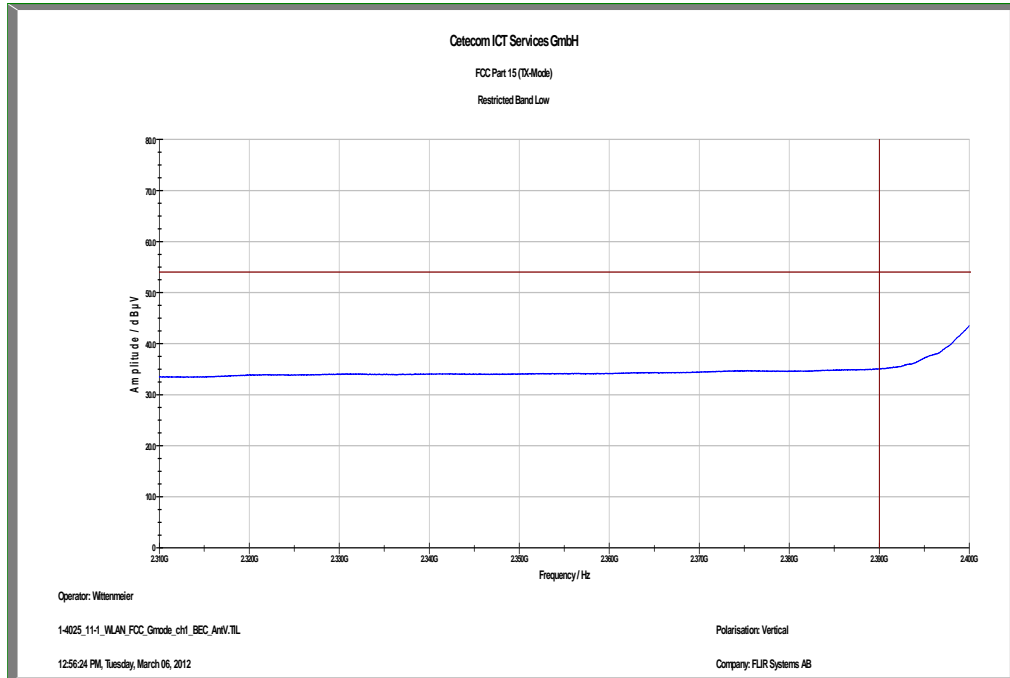

Plot 2: TX mode, upper band edge, vertical polarization

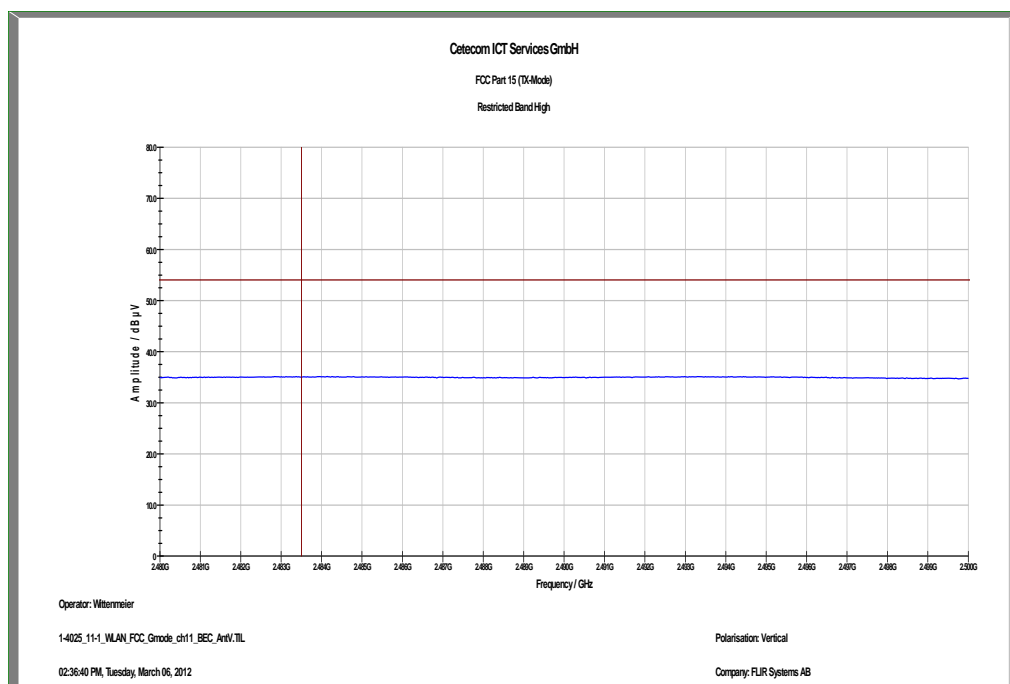

Plot 3: TX mode, lower band edge, horizontal polarization

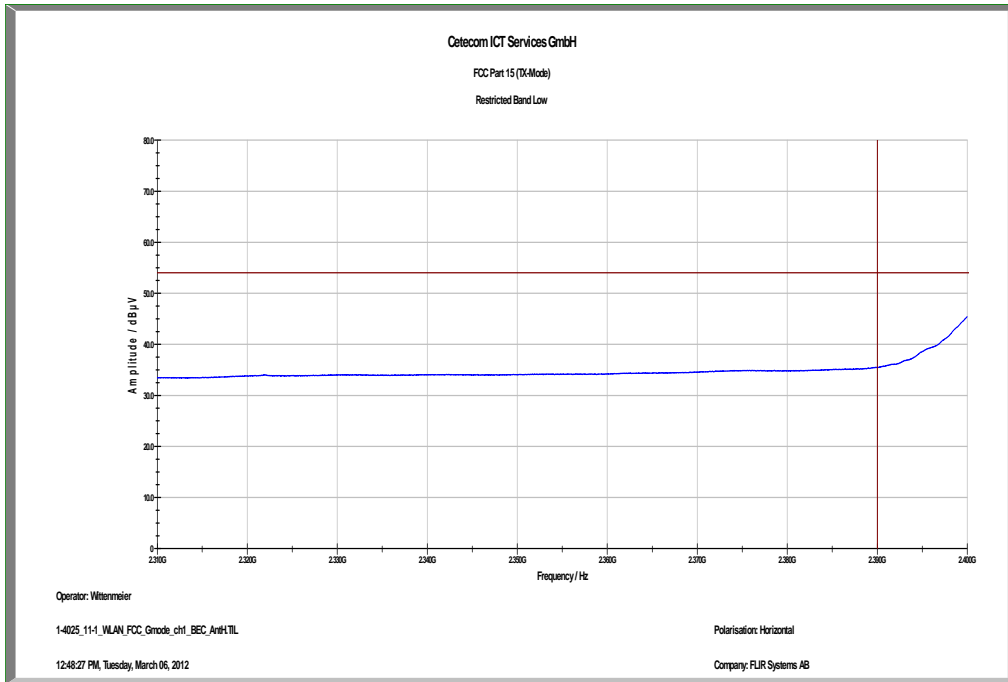

Plot 4: TX mode, upper band edge, horizontal polarization

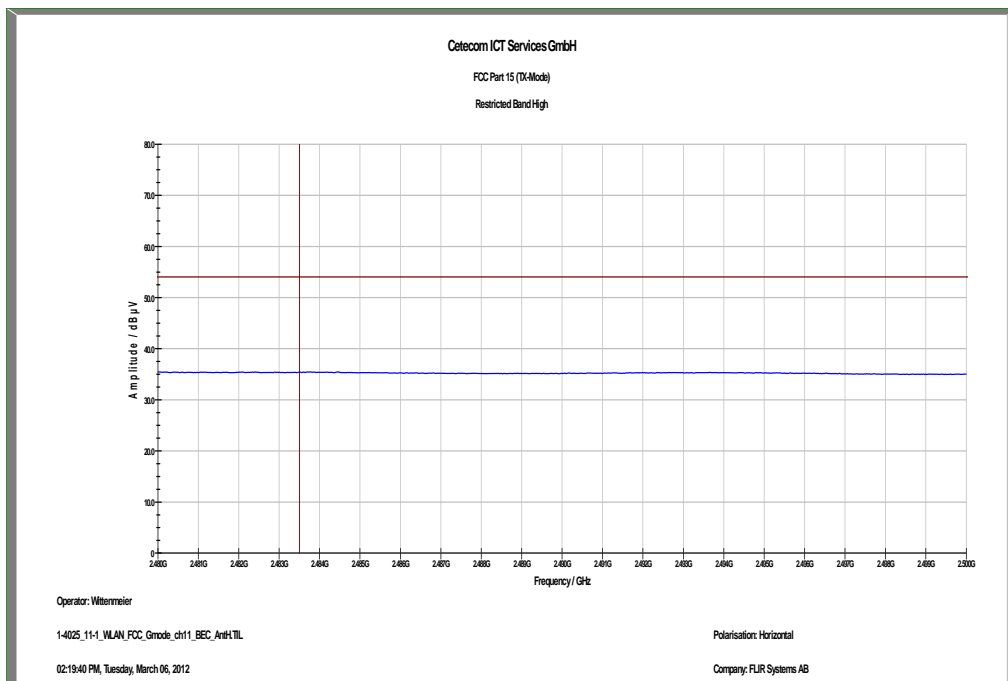

9.9 TX spurious emissions conducted

Description:

Measurement of the conducted spurious emissions in transmit mode. The measurement is performed at channel 1, 6 and 11. The measurement is repeated for all modulations.

Measurement:

Measurement parameter	
Detector:	Peak
Sweep time:	1s / 100 MHz
Resolution bandwidth:	F < 1 GHz: 100 kHz F > 1 GHz: 100 kHz
Video bandwidth:	F < 1 GHz: 500 kHz F > 1 GHz: 500 kHz
Span:	9 kHz to 25 GHz
Trace-Mode:	Max Hold

Limits:

FCC	IC
TX Spurious Emissions Conducted	
<p>In any 100 kHz bandwidth outside the frequency band in which the spread spectrum or digitally modulated intentional radiator is operating, the radio frequency power that is produced by the intentional radiator shall be at least 20 dB below that in the 100 kHz bandwidth within the band that contains the highest level of the desired power, based on either an RF conducted or a radiated measurement. Attenuation below the general limits specified in Section 15.209(a) is not required</p>	

Results: DSSS / b – mode

TX Spurious Emissions Conducted					
DSSS / b – mode					
f [MHz]		amplitude of emission [dBm]	limit max. allowed emission power	actual attenuation below frequency of operation [dB]	results
2412			30 dBm		Operating frequency
No critical peaks detected. All detected emissions are below the -20 dBc criteria.			-20 dBc (peak) -30 dBc (average)		complies
2437			30 dBm		Operating frequency
No critical peaks detected. All detected emissions are below the -20 dBc criteria.			-20 dBc (peak) -30 dBc (average)		complies
2462			30 dBm		Operating frequency
No critical peaks detected. All detected emissions are below the -20 dBc criteria.			-20 dBc (peak) -30 dBc (average)		complies
Measurement uncertainty			± 3 dB		

Result: Passed

Results: OFDM / g – mode

TX Spurious Emissions Conducted					
OFDM / g – mode					
f [MHz]		amplitude of emission [dBm]	limit max. allowed emission power	actual attenuation below frequency of operation [dB]	results
2412			30 dBm		Operating frequency
No critical peaks detected. All detected emissions are below the -20 dBc criteria.			-20 dBc (peak) -30 dBc (average)		complies
2437			30 dBm		Operating frequency
No critical peaks detected. All detected emissions are below the -20 dBc criteria.			-20 dBc (peak) -30 dBc (average)		complies
2462			30 dBm		Operating frequency
No critical peaks detected. All detected emissions are below the -20 dBc criteria.			-20 dBc (peak) -30 dBc (average)		complies
Measurement uncertainty			± 3 dB		

Result: Passed

Plots: DSSS / b – mode

Plot 1: TX mode, lowest channel, up to 1 GHz

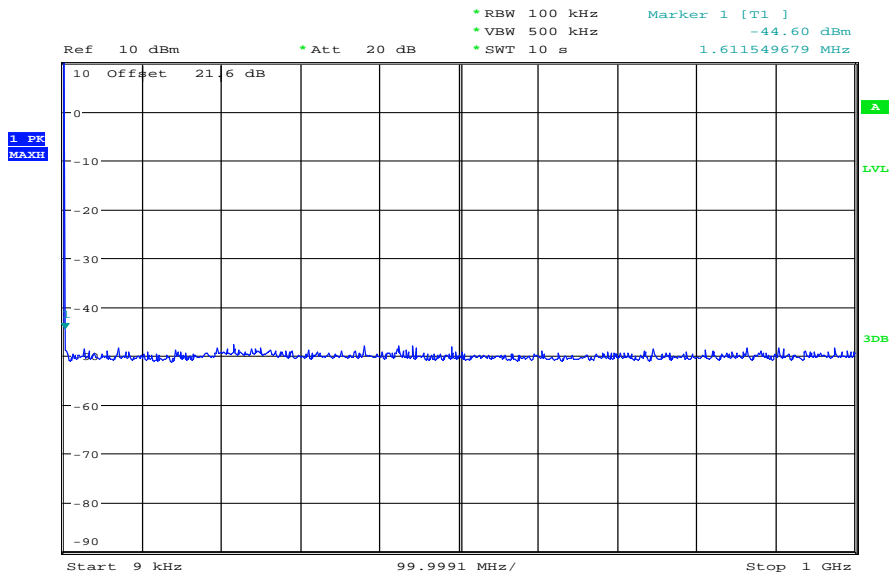

Date: 28.JUN.2012 12:43:37

Plot 2: TX mode, lowest channel, 1 GHz to 12 GHz

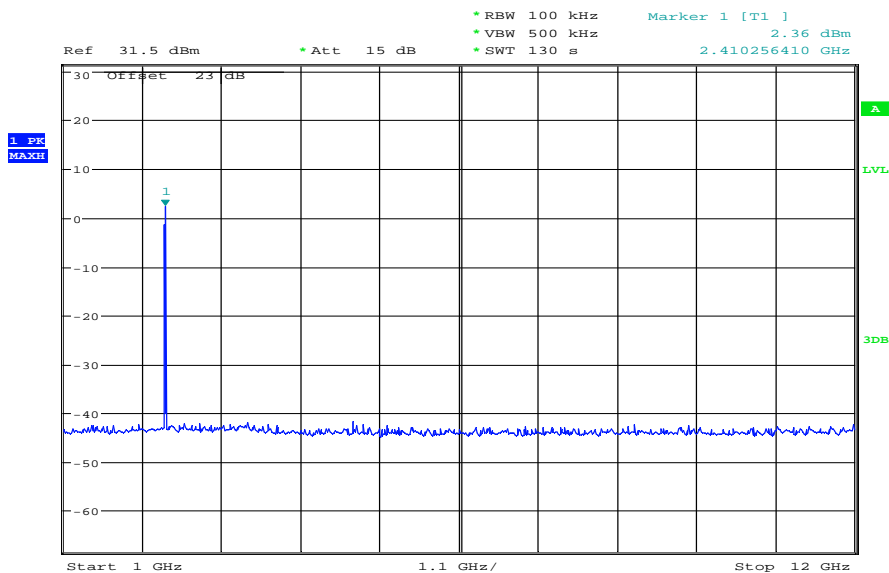

Date: 6.MAR.2012 07:20:39

Plot 3: TX mode, lowest channel, 12 GHz to 26 GHz

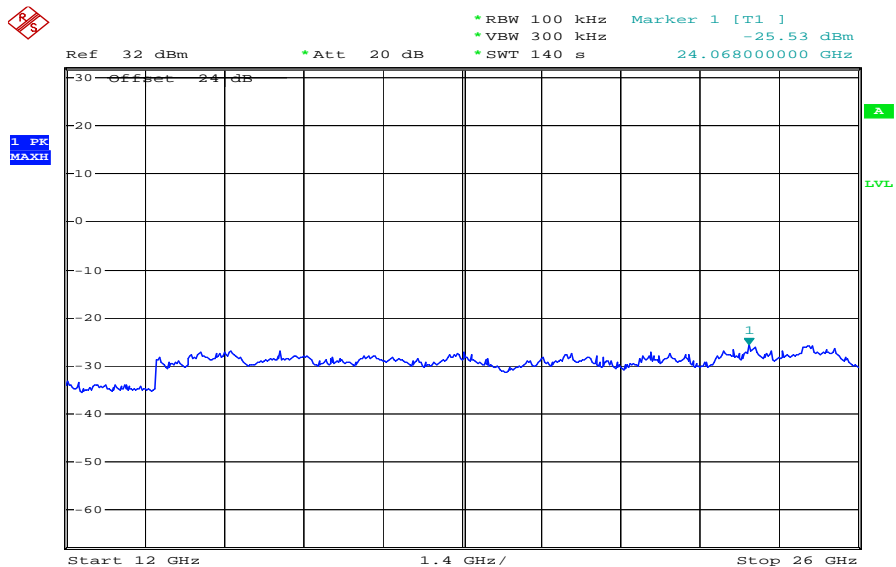

Date: 6.MAR.2012 08:56:36

Plot 4: TX mode, middle channel, up to 1 GHz

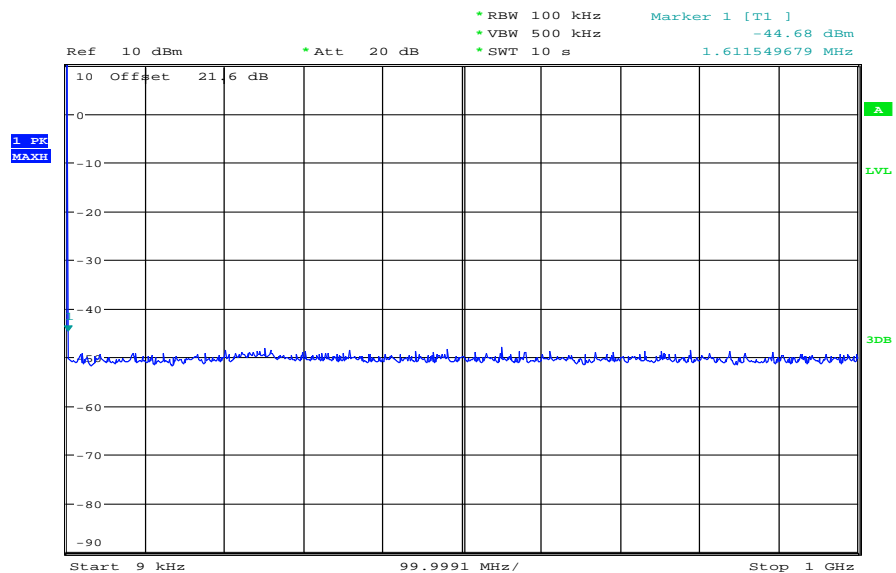

Date: 28.JUN.2012 12:44:06

Plot 5: TX mode, middle channel, 1 GHz to 12 GHz

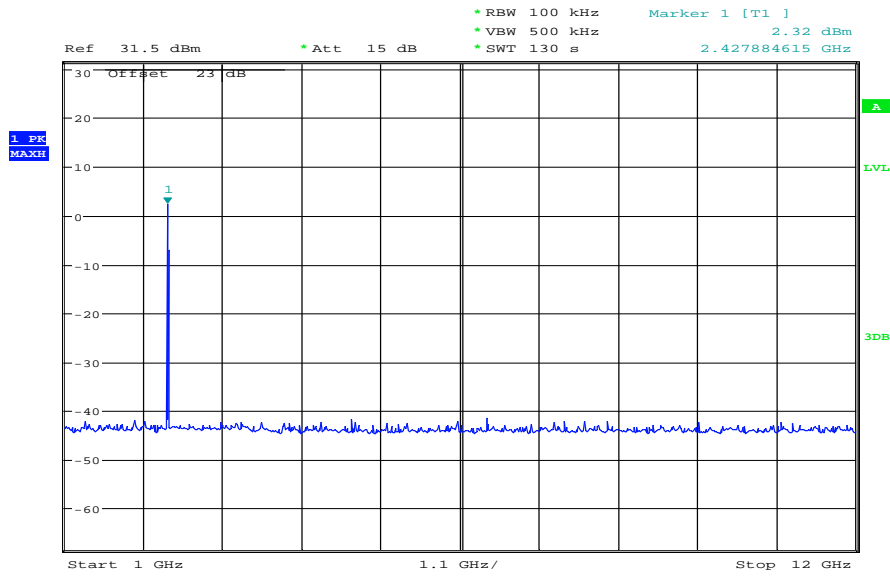

Date: 6.MAR.2012 07:17:32

Plot 6: TX mode, middle channel, 12 GHz to 26 GHz

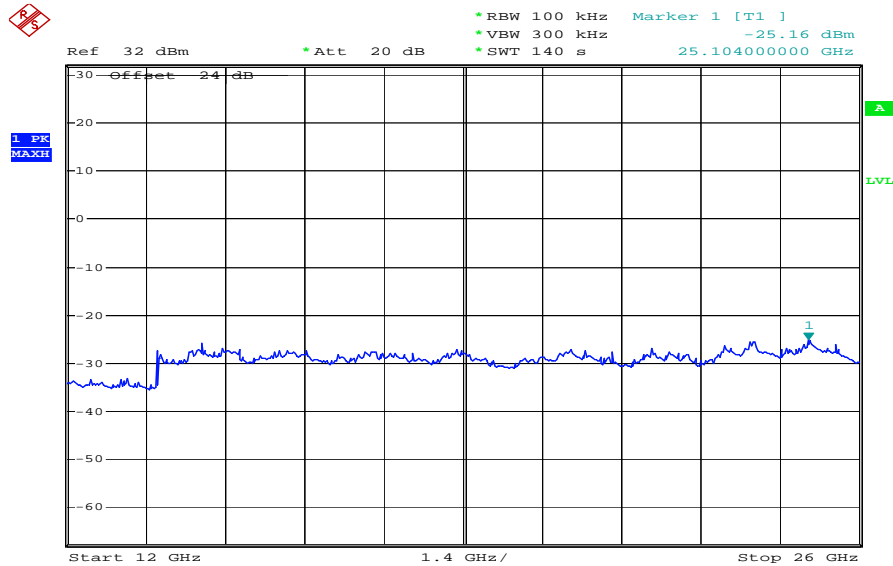

Date: 6.MAR.2012 08:51:28

Plot 7: TX mode, highest channel, up to 1 GHz

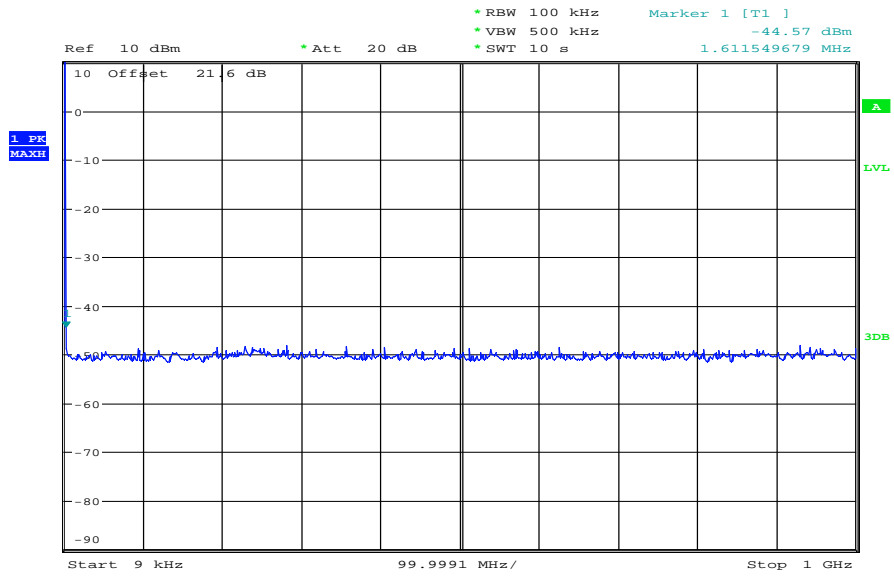

Date: 28.JUN.2012 12:44:38

Plot 8: TX mode, highest channel, 1 GHz to 12 GHz

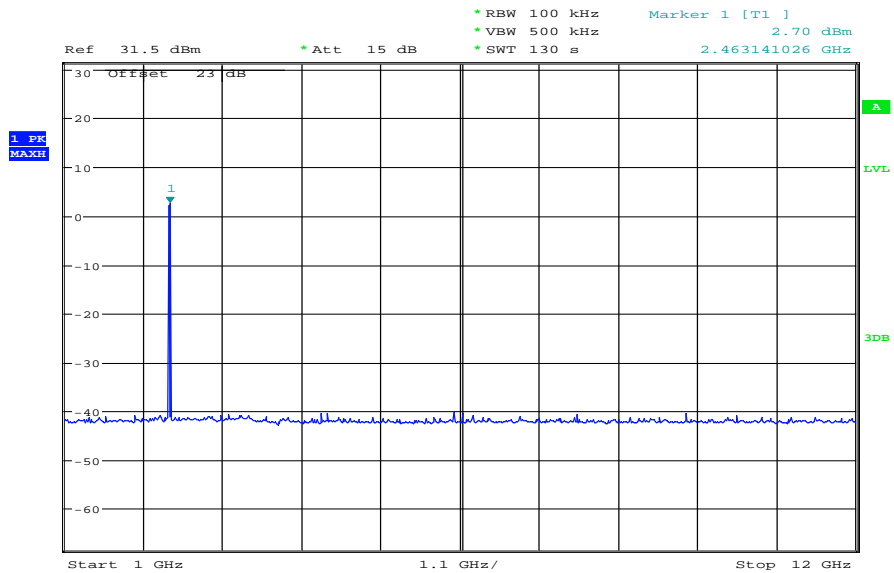

Date: 6.MAR.2012 07:14:39

Plot 9: TX mode, highest channel, 12 GHz to 26 GHz

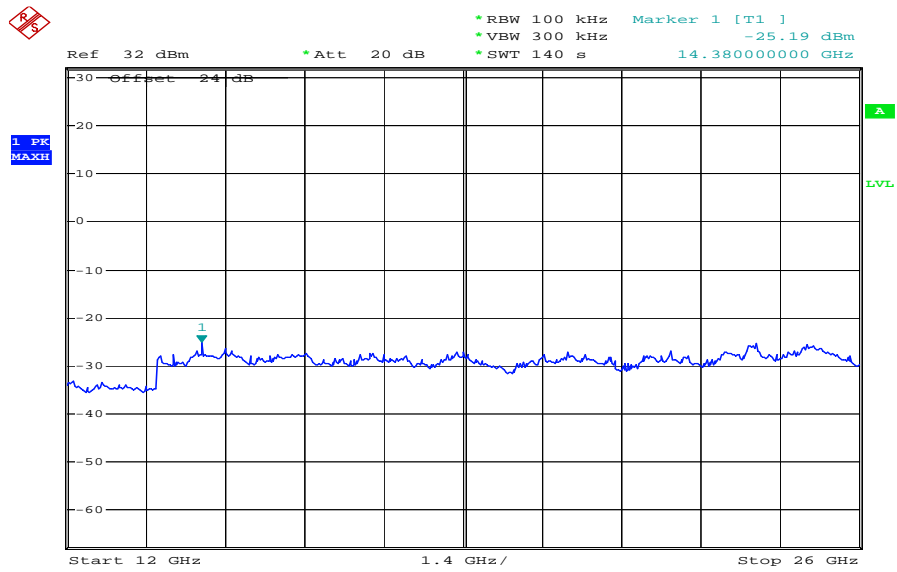

Date: 6.MAR.2012 08:46:09

Plots: OFDM / g – mode

Plot 1: TX mode, lowest channel, up to 1 GHz

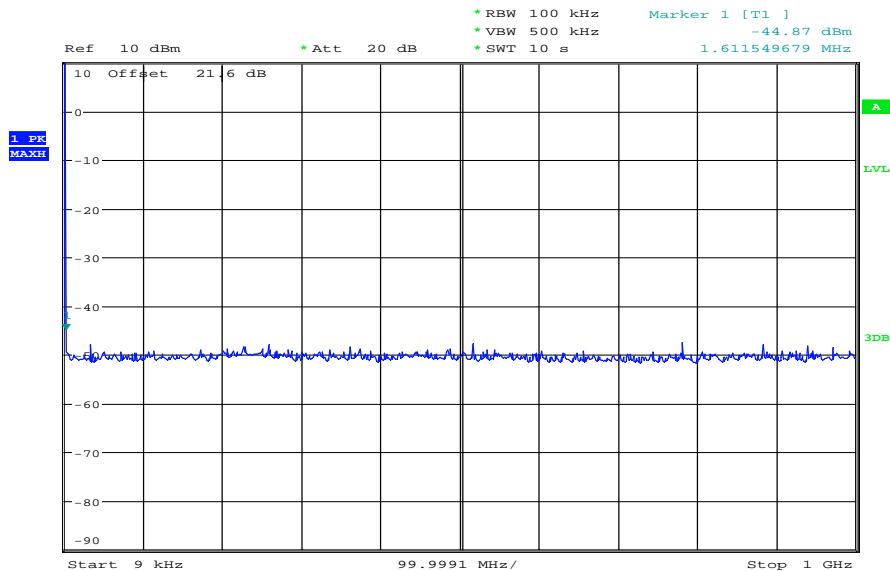

Date: 28.JUN.2012 12:45:10

Plot 2: TX mode, lowest channel, 1 GHz to 12 GHz

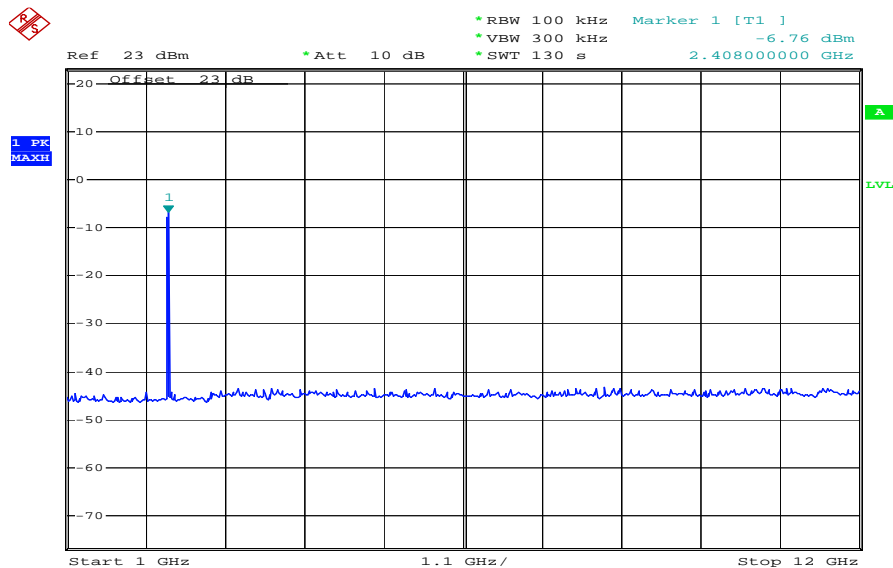

Date: 6.MAR.2012 09:31:08

Plot 3: TX mode, lowest channel, 12 GHz to 26 GHz

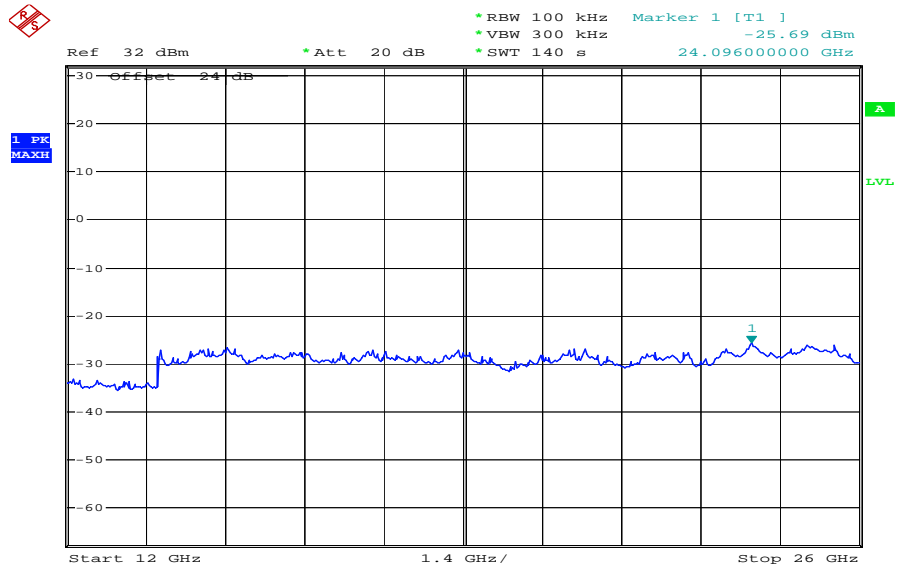

Date: 6.MAR.2012 09:02:20

Plot 4: TX mode, middle channel, up to 1 GHz

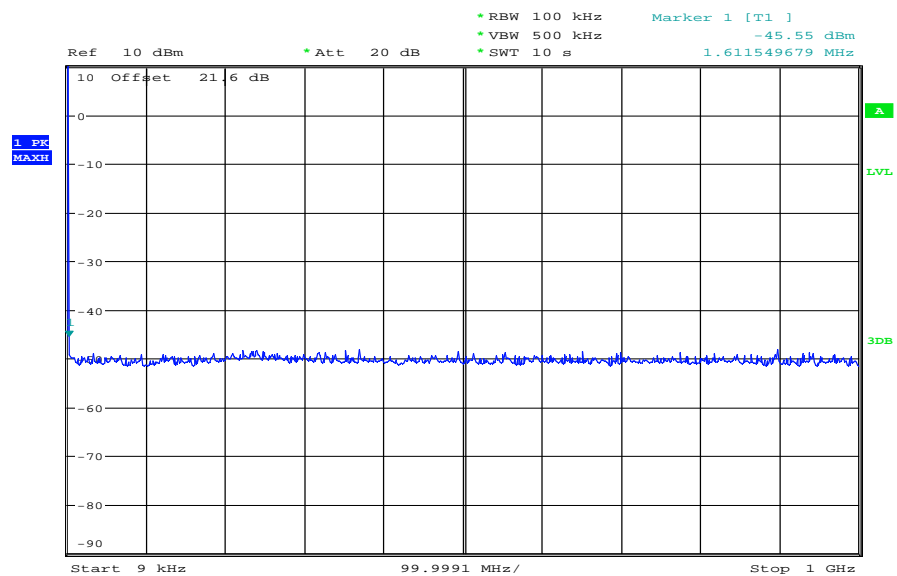

Date: 28.JUN.2012 12:45:38

Plot 5: TX mode, middle channel, 1 GHz to 12 GHz

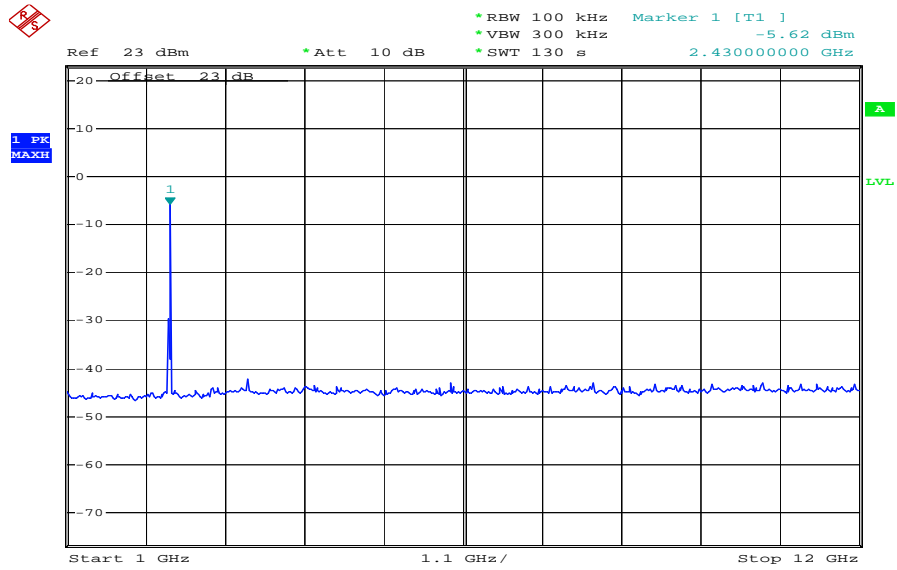

Date: 6.MAR.2012 09:26:20

Plot 6: TX mode, middle channel, 12 GHz to 26 GHz

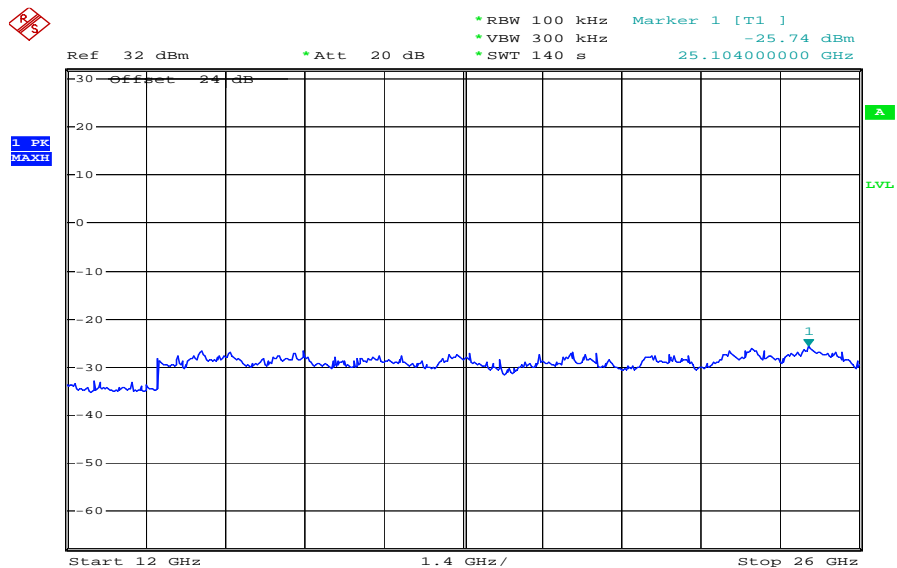

Date: 6.MAR.2012 09:07:42

Plot 7: TX mode, highest channel, up to 1 GHz

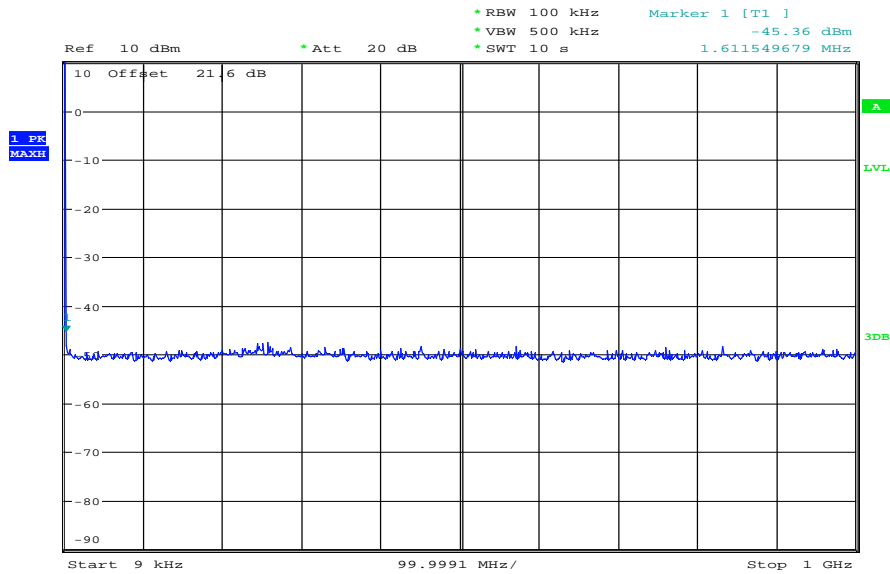

Date: 28.JUN.2012 12:46:17

Plot 8: TX mode, highest channel, 1 GHz to 12 GHz

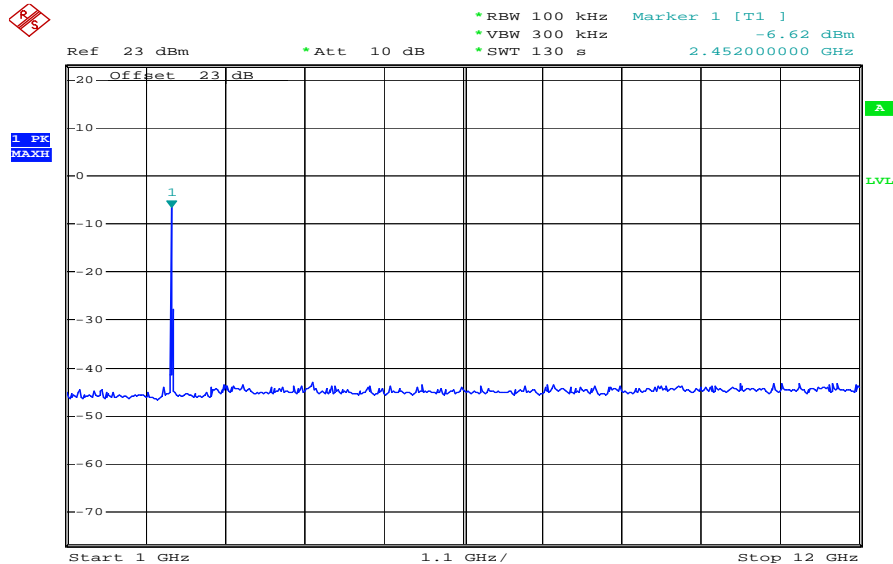

Date: 6.MAR.2012 09:20:04

Plot 9: TX mode, highest channel, 12 GHz to 26 GHz

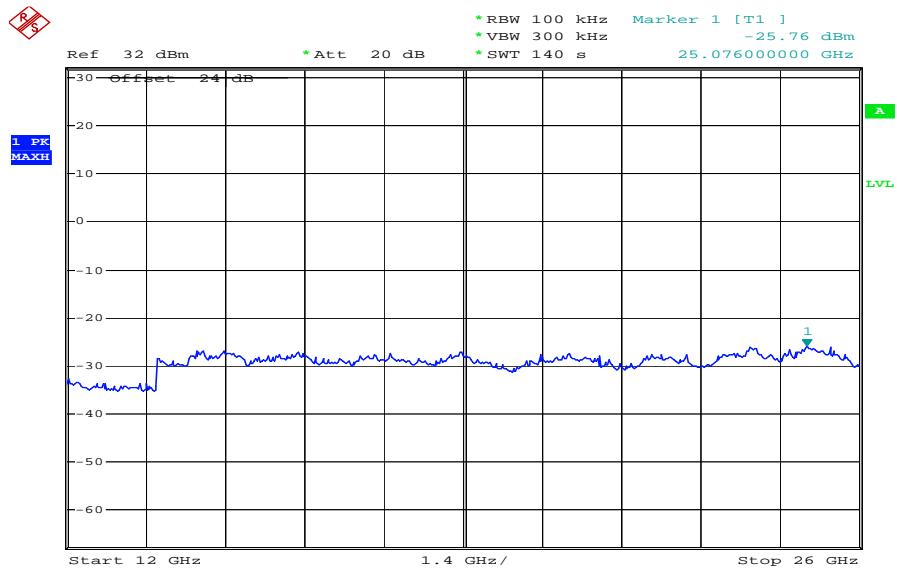

Date: 6.MAR.2012 09:14:19

9.10 TX spurious emissions radiated

Description:

Measurement of the radiated spurious emissions in transmit mode. The measurement is performed at channel 1, 6 and 11. The measurement is repeated for all modulations.

Measurement:

Measurement parameter	
Detector:	Peak / Quasi Peak / RMS
Sweep time:	Auto
Resolution bandwidth:	F > 1 GHz: 1 MHz F < 1 GHz: 100 kHz
Video bandwidth:	Sweep: 100 kHz Remeasurement: 10 Hz / 3 MHz
Span:	30 MHz to 25 GHz
Trace-Mode:	Max Hold
Measured Modulation	<input checked="" type="checkbox"/> DSSS b – mode <input checked="" type="checkbox"/> OFDM g – mode

The modulation with the highest output power was used to perform the transmitter spurious emissions. If spurious were detected a re-measurement was performed on the detected frequency with each modulation.

Limits:

FCC	IC	
TX Spurious Emissions Radiated		
<p>In any 100 kHz bandwidth outside the frequency band in which the spread spectrum or digitally modulated intentional radiator is operating, the radio frequency power that is produced by the intentional radiator shall be at least 20 dB below that in the 100 kHz bandwidth within the band that contains the highest level of the desired power, based on either an RF conducted or a radiated measurement. Attenuation below the general limits specified in Section 15.209(a) is not required. In addition, radiated emissions which fall in the restricted bands, as defined in §15.205(a), must also comply with the radiated emission limits specified in §15.209(a) (see §15.205(c)).</p>		
Frequency (MHz)	Field Strength (dBµV/m)	Measurement distance
30 - 88	30.0	10
88 – 216	33.5	10
216 – 960	36.0	10
Above 960	54.0	3

Results: DSSS / b – mode

TX Spurious Emissions Radiated [dBµV/m]								
DSSS / b – mode								
2412 MHz			2437 MHz			2462 MHz		
F [MHz]	Detector	Level [dBµV/m]	F [MHz]	Detector	Level [dBµV/m]	F [MHz]	Detector	Level [dBµV/m]
For emissions below 1 GHz, please take a look at the table below the 1 GHz plot.			For emissions below 1 GHz, please take a look at the table below the 1 GHz plot.			For emissions below 1 GHz, please take a look at the table below the 1 GHz plot.		
1400	Peak	40.01	1600	Peak	41.49	1620	Peak	40.79
1600	Peak	45.46				2060	Peak	44.01
Measurement uncertainty			± 3 dB					

Result: Passed

Results: OFDM / g – mode

TX Spurious Emissions Radiated [dBµV/m]								
OFDM / g – mode								
2412 MHz			2437 MHz			2462 MHz		
F [MHz]	Detector	Level [dBµV/m]	F [MHz]	Detector	Level [dBµV/m]	F [MHz]	Detector	Level [dBµV/m]
For emissions below 1 GHz, please take a look at the table below the 1 GHz plot.			For emissions below 1 GHz, please take a look at the table below the 1 GHz plot.			For emissions below 1 GHz, please take a look at the table below the 1 GHz plot.		
No critical peaks detected. All detected peak values are below the average limit.			1.890	Peak	41.16	1320	Peak	41.70
			2060	Peak	41.69	1890	Peak	42.44
						2062	Peak	41.53
Measurement uncertainty			± 3 dB					

Result: Passed

Plots: DSSS / b – mode

Plot 1: Lowest channel, 30 MHz to 1 GHz, vertical & horizontal polarization

Common Information

EUT: T4xx Core (T198200)
 Serial Number: 62000140
 Test Description: FCC part 15 class B @ 10 m
 Operating Conditions: WLAN b-mode TX Ch. 1 + charging
 Operator Name: Hennemann
 Comment: AC: 115 V / 60 Hz

Scan Setup: STAN_Fin [EMI radiated]

Hardware Setup: Electric Field (NOS)
 Receiver: [ESCI 3]
 Level Unit: dBµV/m
Subrange **Step Size** **Detectors** **IF BW** **Meas. Time** **Preamp**
 30 MHz - 2 GHz 60 kHz QPK 120 kHz 1 s 20 dB

FCC_10m(B)_3

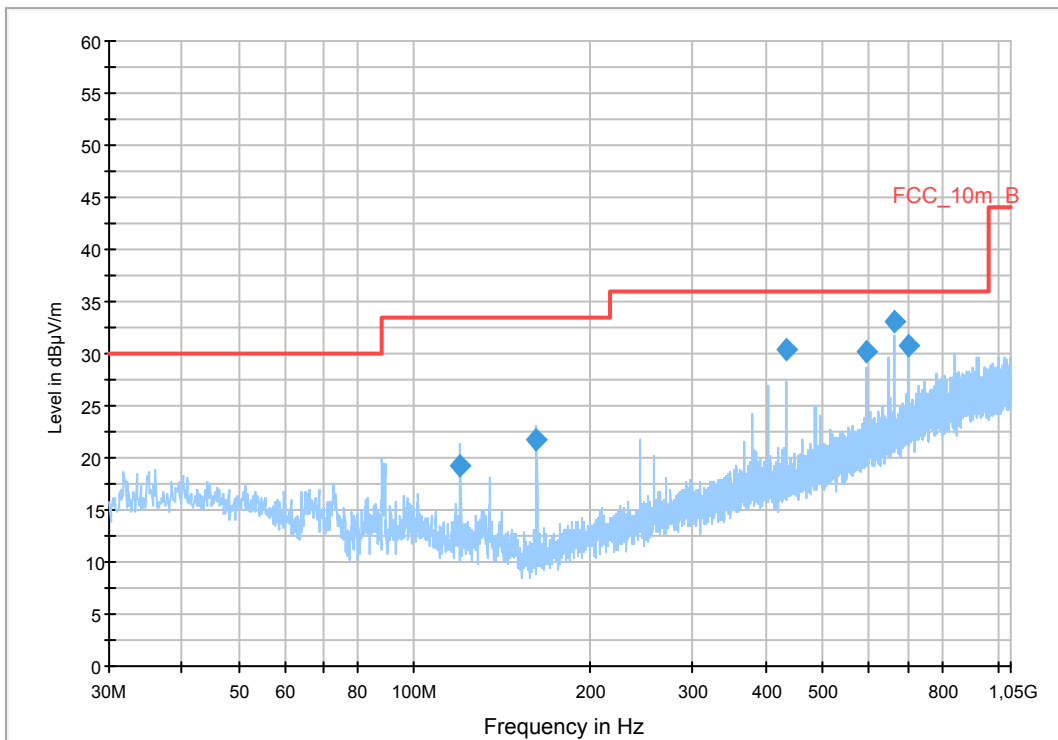

Final Result 1

Frequency (MHz)	QuasiPeak (dBµV/m)	Meas. Time (ms)	Bandwidth (kHz)	Height (cm)	Polarization	Azimuth (deg)	Corr. (dB)	Margin (dB)	Limit (dBµV/m)	Comment
119.988900	19.2	1000.0	120.000	170.0	V	-4.0	10.2	14.3	33.5	
162.015600	21.7	1000.0	120.000	98.0	V	94.0	9.3	11.8	33.5	
432.007500	30.4	1000.0	120.000	170.0	H	8.0	17.4	5.6	36.0	
593.986050	30.1	1000.0	120.000	170.0	H	283.0	20.6	5.9	36.0	
662.801250	33.1	1000.0	120.000	156.0	H	-7.0	21.5	2.9	36.0	
701.998200	30.8	1000.0	120.000	146.0	H	-7.0	22.5	5.2	36.0	

Plot 2: Lowest channel, 1 GHz to 12.75 GHz, vertical polarization

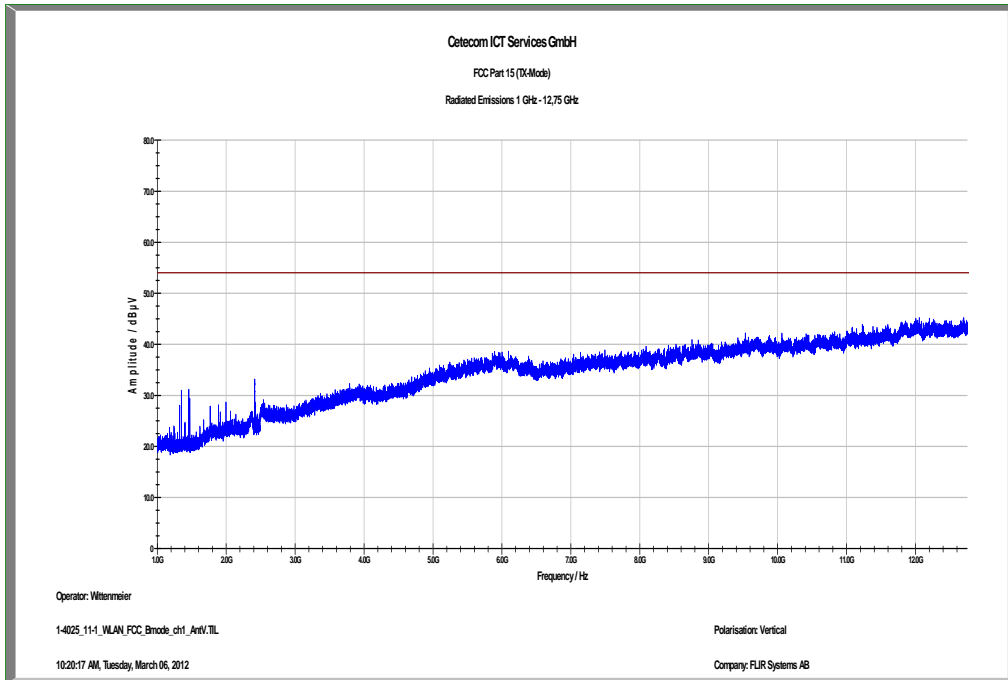

The carrier signal is notched with a 2.4 GHz band rejection filter.

Plot 3: Lowest channel, 1 GHz to 12.75 GHz, horizontal polarization

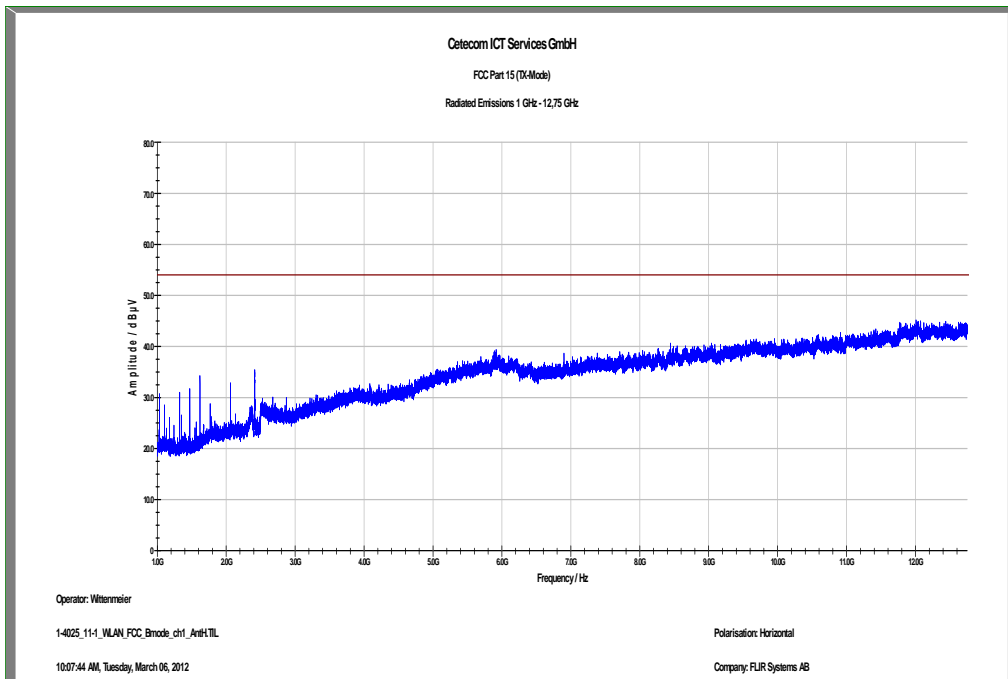

The carrier signal is notched with a 2.4 GHz band rejection filter.

Plot 4: Lowest channel, 12.75 GHz to 18 GHz, vertical & horizontal polarization

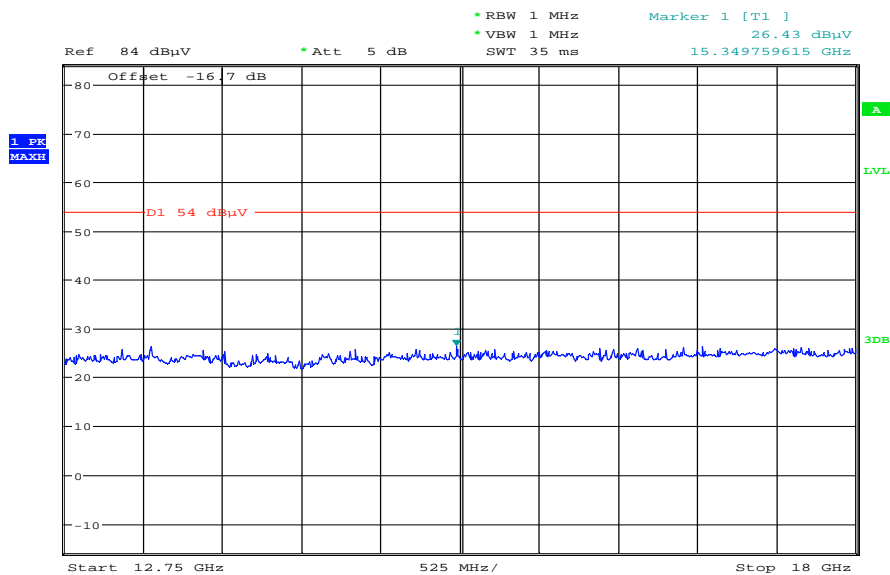

Date: 28.JUN.2012 12:55:44

Plot 5: Lowest channel, 18 GHz to 26 GHz, vertical & horizontal polarization

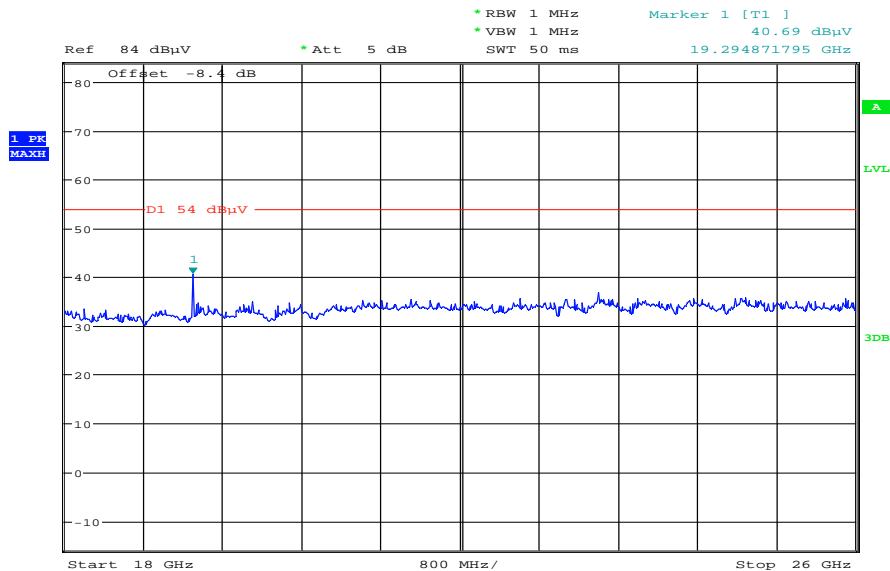

Date: 28.JUN.2012 13:03:33

Plot 6: Middle channel, 30 MHz to 1 GHz, vertical & horizontal polarization

Common Information

EUT: T4xx Core (T198200)
 Serial Number: 62000140
 Test Description: FCC part 15 class B @ 10 m
 Operating Conditions: WLAN b-mode TX Ch. 6 + charging
 Operator Name: Hennemann
 Comment: AC: 115 V / 60 Hz

Scan Setup: STAN_Fin [EMI radiated]

Hardware Setup: Electric Field (NOS)
 Receiver: [ESCI 3]
 Level Unit: dBµV/m
Subrange **Step Size** **Detectors** **IF BW** **Meas. Time** **Preamp**
 30 MHz - 2 GHz 60 kHz QPK 120 kHz 1 s 20 dB

FCC_10m(B)_3

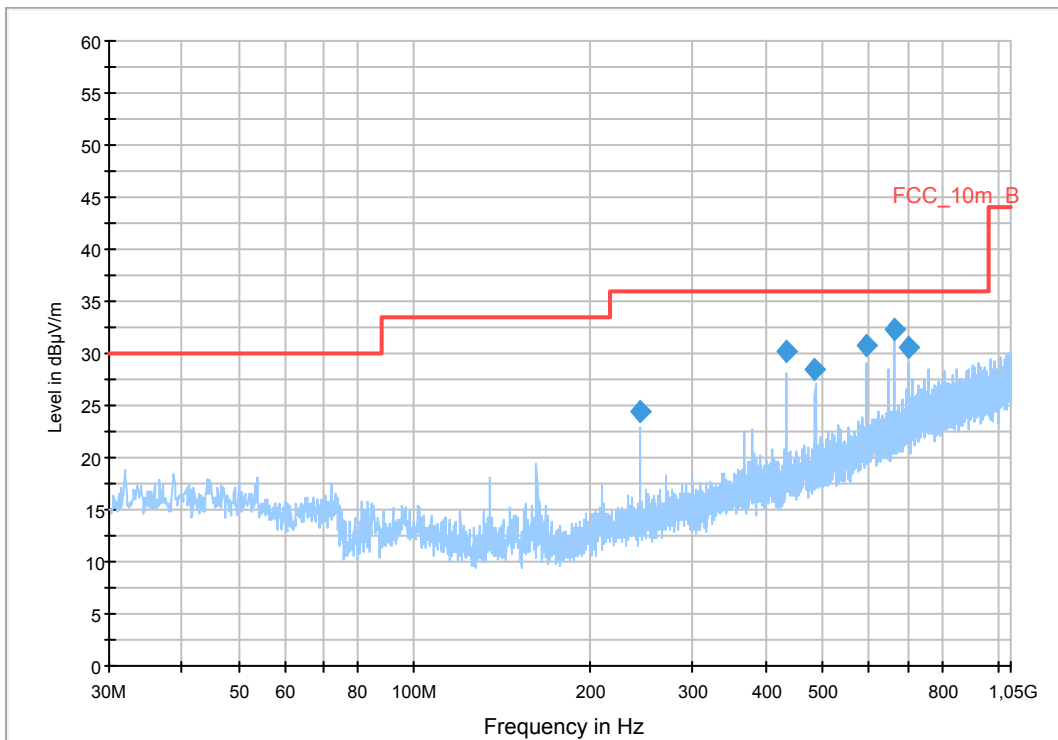

Final Result 1

Frequency (MHz)	QuasiPeak (dBµV/m)	Meas. Time (ms)	Bandwidth (kHz)	Height (cm)	Polarization	Azimuth (deg)	Corr. (dB)	Margin (dB)	Limit (dBµV/m)	Comment
243.029400	24.4	1000.0	120.000	98.0	V	-4.0	13.1	11.6	36.0	
432.007650	30.1	1000.0	120.000	170.0	H	8.0	17.4	5.9	36.0	
486.002700	28.4	1000.0	120.000	170.0	H	0.0	18.4	7.6	36.0	
593.996550	30.8	1000.0	120.000	170.0	H	283.0	20.6	5.2	36.0	
662.816100	32.3	1000.0	120.000	144.0	H	0.0	21.5	3.7	36.0	
701.998500	30.6	1000.0	120.000	135.0	H	-2.0	22.5	5.4	36.0	

Plot 7: Middle channel, 1 GHz to 12.75 GHz, vertical polarization

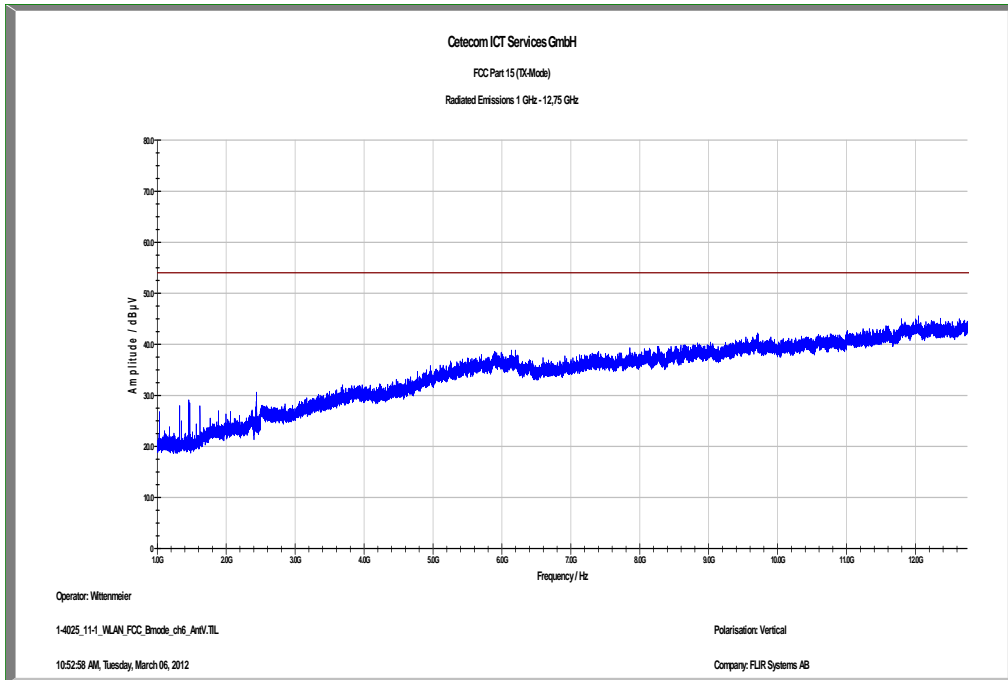

The carrier signal is notched with a 2.4 GHz band rejection filter.

Plot 8: Middle channel, 1 GHz to 12.75 GHz, horizontal polarization

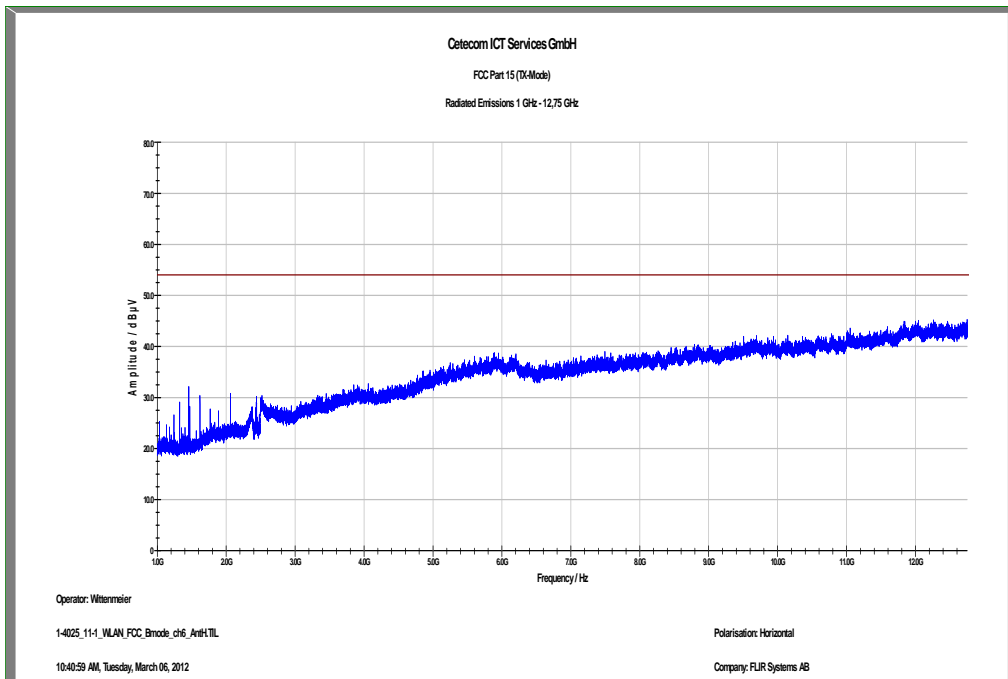

The carrier signal is notched with a 2.4 GHz band rejection filter.

Plot 11: Highest channel, 30 MHz to 1 GHz, vertical & horizontal polarization

Common Information

EUT: T4xx Core (T198200)
 Serial Number: 62000140
 Test Description: FCC part 15 class B @ 10 m
 Operating Conditions: WLAN b-mode TX Ch. 11 + charging
 Operator Name: Hennemann
 Comment: AC: 115 V / 60 Hz

Scan Setup: STAN_Fin [EMI radiated]

Hardware Setup: Electric Field (NOS)
 Receiver: [ESCI 3]
 Level Unit: dBµV/m

Subrange	Step Size	Detectors	IF BW	Meas. Time	Preamp
30 MHz - 2 GHz	60 kHz	QPK	120 kHz	1 s	20 dB

FCC_10m(B)_3

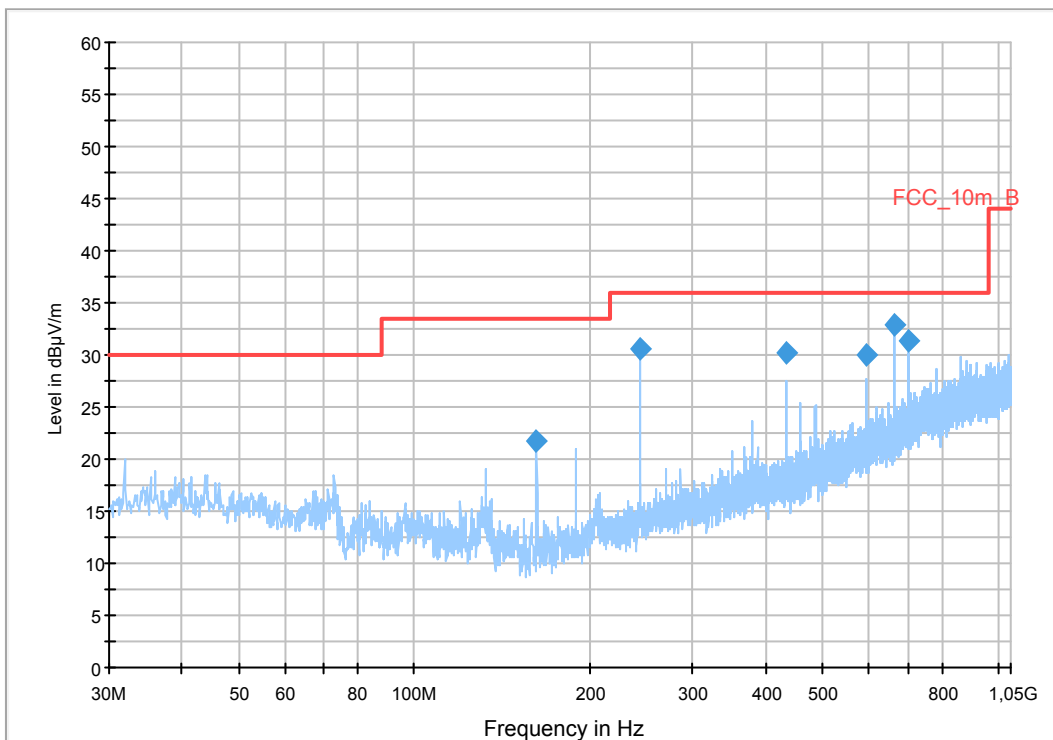

Final Result 1

Frequency (MHz)	QuasiPeak (dBµV/m)	Meas. Time (ms)	Bandwidth (kHz)	Height (cm)	Polarization	Azimuth (deg)	Corr. (dB)	Margin (dB)	Limit (dBµV/m)	Comment
161.998050	21.8	1000.0	120.000	98.0	V	106.0	9.3	11.7	33.5	
242.998650	30.6	1000.0	120.000	98.0	V	283.0	13.1	5.4	36.0	
432.001950	30.3	1000.0	120.000	170.0	H	8.0	17.4	5.7	36.0	
593.993700	30.0	1000.0	120.000	170.0	H	283.0	20.6	6.0	36.0	
662.810550	32.8	1000.0	120.000	170.0	H	-7.0	21.5	3.2	36.0	
701.988000	31.4	1000.0	120.000	135.0	H	-7.0	22.5	4.6	36.0	

Plot 12: Highest channel, 1 GHz to 12.75 GHz, vertical polarization

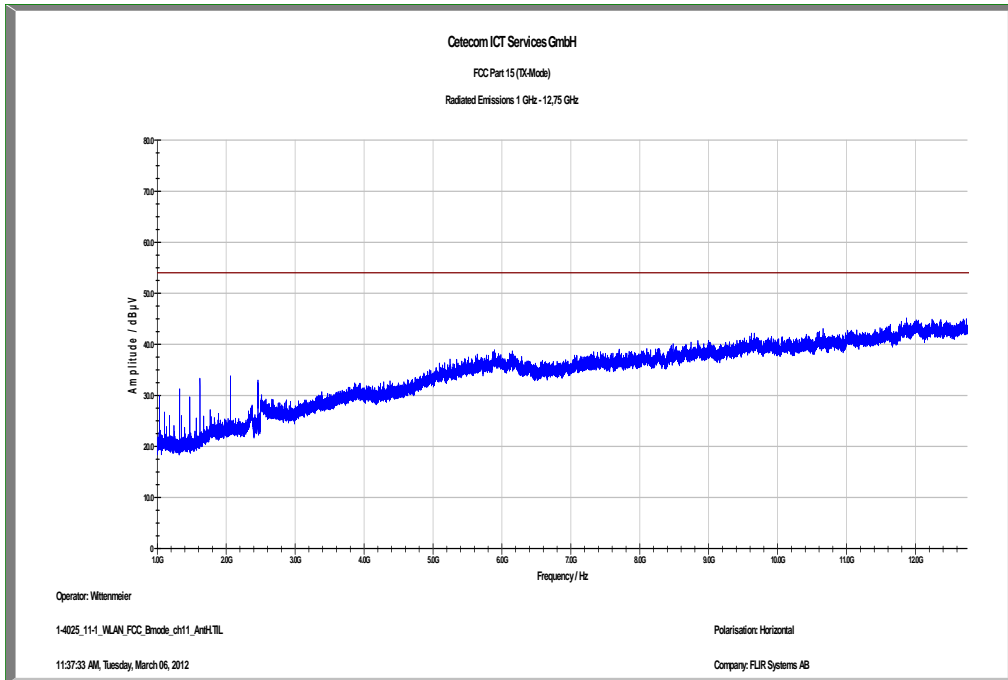

The carrier signal is notched with a 2.4 GHz band rejection filter.

Plot 13: Highest channel, 1 GHz to 12.75 GHz, horizontal polarization

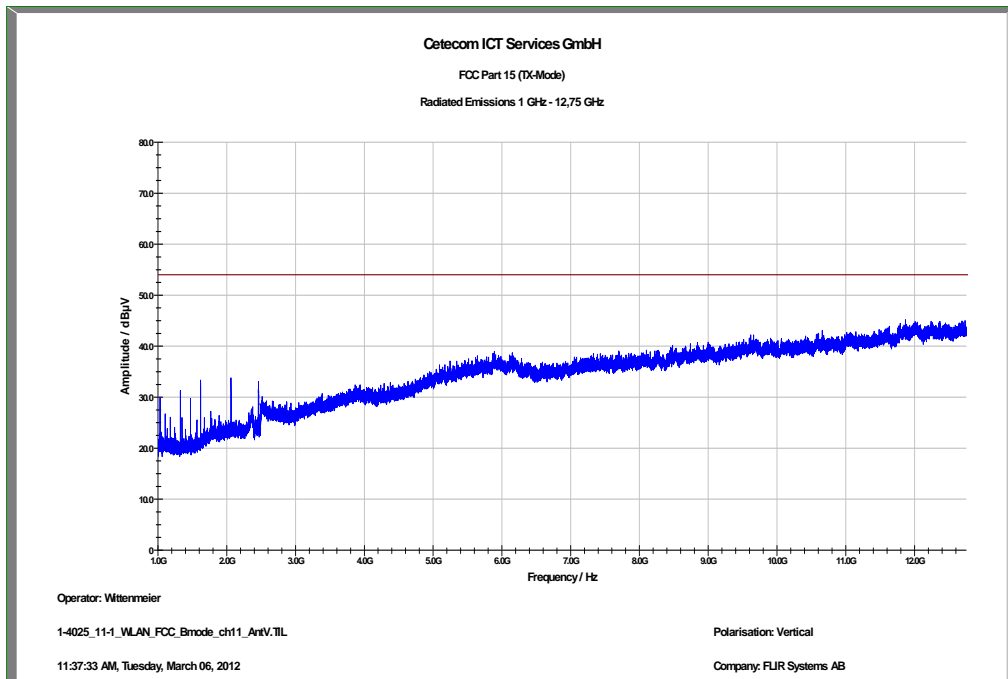

The carrier signal is notched with a 2.4 GHz band rejection filter.

Plots: OFDM / g – mode

Plot 1: Lowest channel, 30 MHz to 1 GHz, vertical & horizontal polarization

Common Information

EUT: T4xx Core (T198200)
 Serial Number: 62000140
 Test Description: FCC part 15 class B @ 10 m
 Operating Conditions: WLAN g-mode TX Ch. 1 + charging
 Operator Name: Hennemann
 Comment: AC: 115 V / 60 Hz

Scan Setup: STAN_Fin [EMI radiated]

Hardware Setup: Electric Field (NOS)
 Receiver: [ESCI 3]
 Level Unit: dBµV/m

Subrange	Step Size	Detectors	IF BW	Meas. Time	Preamp
30 MHz - 2 GHz	60 kHz	QPK	120 kHz	1 s	20 dB

FCC_10m(B)_3

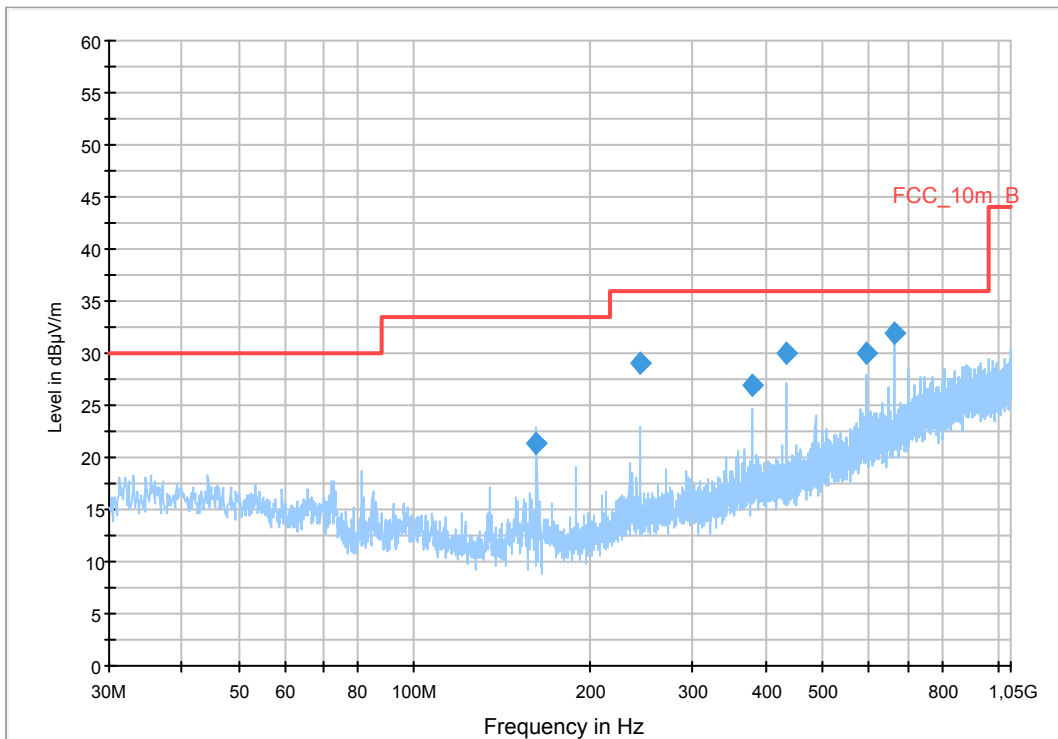

Final Result 1

Frequency (MHz)	QuasiPeak (dBµV/m)	Meas. Time (ms)	Bandwidth (kHz)	Height (cm)	Polarization	Azimuth (deg)	Corr. (dB)	Margin (dB)	Limit (dBµV/m)	Comment
161.988150	21.3	1000.0	120.000	98.0	V	82.0	9.3	12.2	33.5	
242.964150	29.0	1000.0	120.000	98.0	V	270.0	13.1	7.0	36.0	
378.019800	26.9	1000.0	120.000	170.0	H	-7.0	16.5	9.1	36.0	
432.007950	30.0	1000.0	120.000	170.0	H	7.0	17.4	6.0	36.0	
593.996250	30.0	1000.0	120.000	170.0	H	283.0	20.6	6.0	36.0	
662.812200	32.0	1000.0	120.000	135.0	H	196.0	21.5	4.0	36.0	

Plot 2: Lowest channel, 1 GHz to 12.75 GHz, vertical polarization

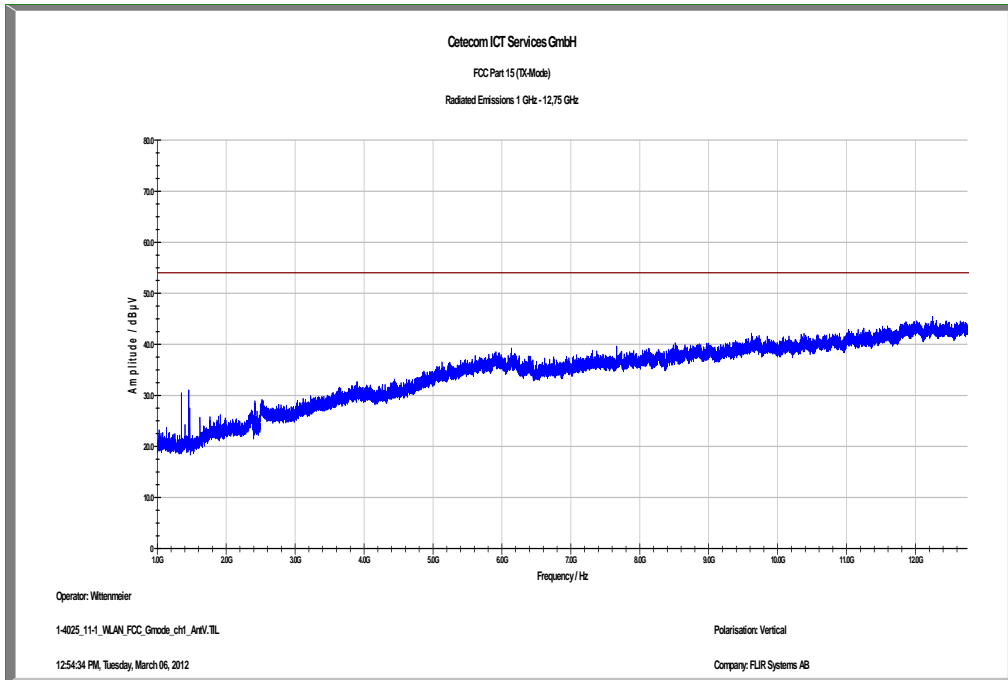

The carrier signal is notched with a 2.4 GHz band rejection filter.

Plot 3: Lowest channel, 1 GHz to 12.75 GHz, horizontal polarization

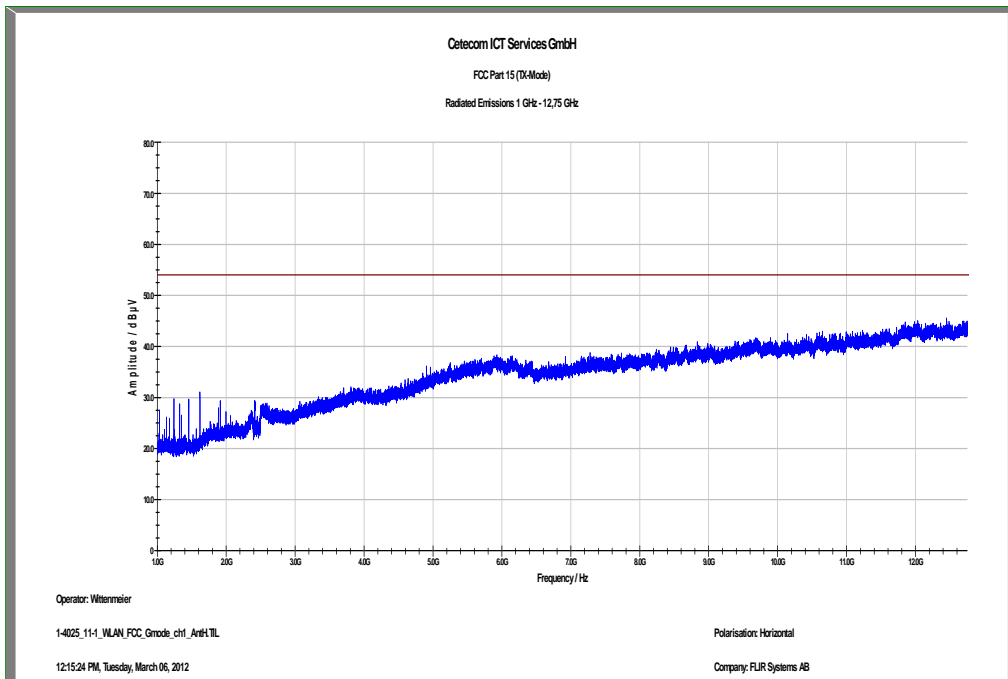

The carrier signal is notched with a 2.4 GHz band rejection filter.

Plot 4: Lowest channel, 12.75 GHz to 18 GHz, vertical & horizontal polarization

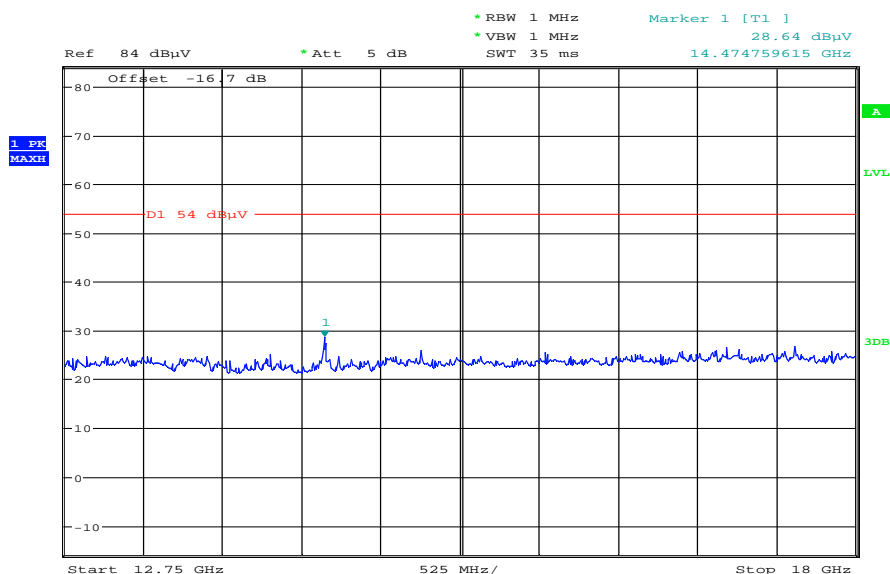

Date: 28.JUN.2012 12:57:59

Plot 5: Lowest channel, 18 GHz to 26 GHz, vertical & horizontal polarization

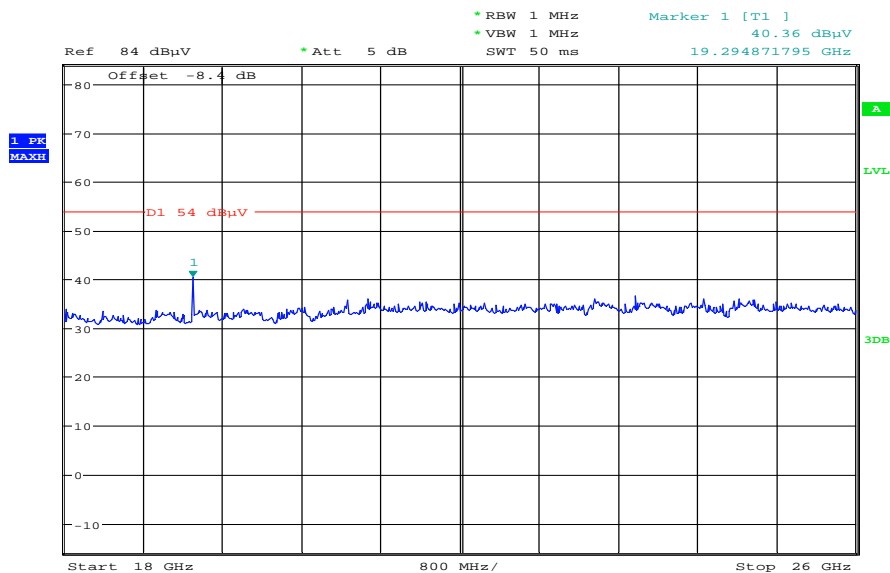

Date: 28.JUN.2012 13:02:39

Plot 6: Middle channel, 30 MHz to 1 GHz, vertical & horizontal polarization

Common Information

EUT: T4xx Core (T198200)
 Serial Number: 62000140
 Test Description: FCC part 15 class B @ 10 m
 Operating Conditions: WLAN g-mode TX Ch. 6 + charging
 Operator Name: Hennemann
 Comment: AC: 115 V / 60 Hz

Scan Setup: STAN_Fin [EMI radiated]

Hardware Setup: Electric Field (NOS)
 Receiver: [ESCI 3]
 Level Unit: dB μ V/m
Subrange **Step Size** **Detectors** **IF BW** **Meas. Time** **Preamp**
 30 MHz - 2 GHz 60 kHz QPK 120 kHz 1 s 20 dB

FCC_10m(B)_3

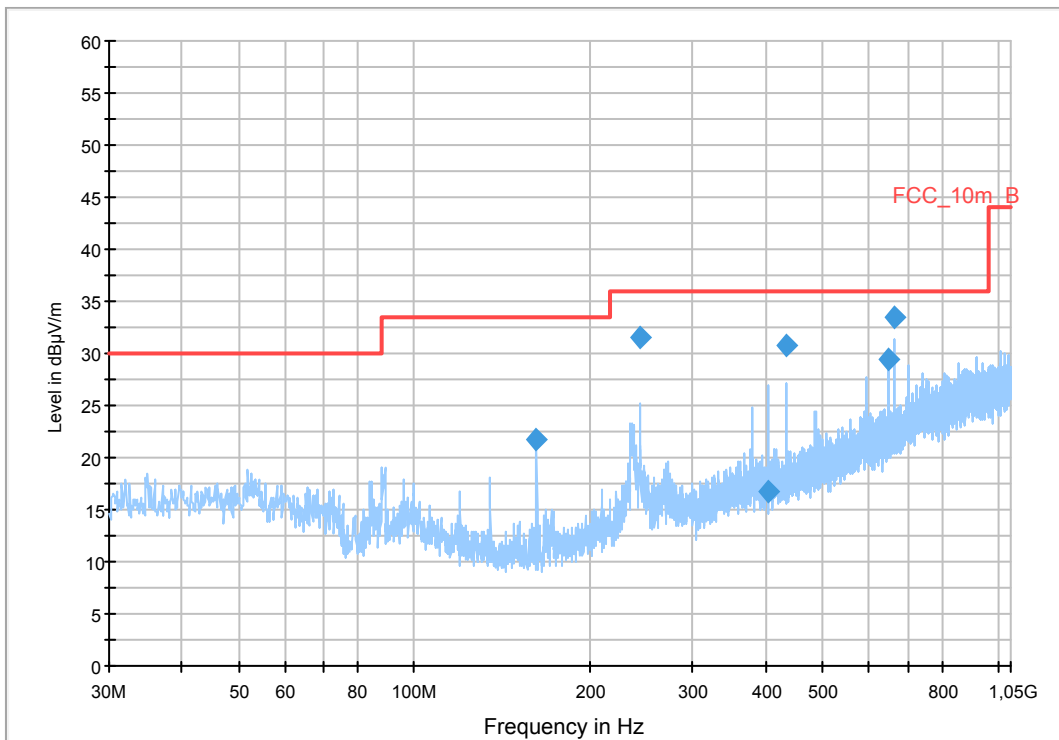

Final Result 1

Frequency (MHz)	QuasiPeak (dB μ V/m)	Meas. Time (ms)	Bandwidth (kHz)	Height (cm)	Polarization	Azimuth (deg)	Corr. (dB)	Margin (dB)	Limit (dB μ V/m)	Comment
161.999400	21.7	1000.0	120.000	98.0	V	106.0	9.3	11.8	33.5	
242.998350	31.6	1000.0	120.000	98.0	V	-7.0	13.1	4.4	36.0	
404.872800	16.7	1000.0	120.000	163.0	H	283.0	17.0	19.3	36.0	
431.986650	30.7	1000.0	120.000	170.0	H	-6.0	17.4	5.3	36.0	
647.989950	29.4	1000.0	120.000	170.0	H	-7.0	21.1	6.6	36.0	
662.795700	33.4	1000.0	120.000	162.0	H	-7.0	21.5	2.6	36.0	

Plot 7: Middle channel, 1 GHz to 12.75 GHz, vertical polarization

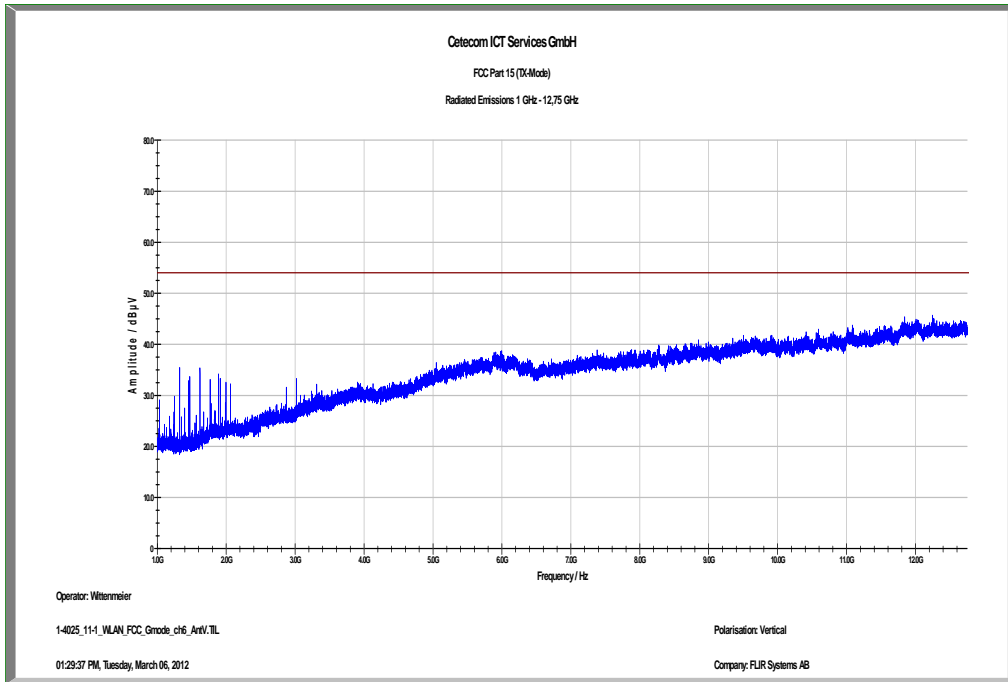

The carrier signal is notched with a 2.4 GHz band rejection filter.

Plot 8: Middle channel, 1 GHz to 12.75 GHz, horizontal polarization

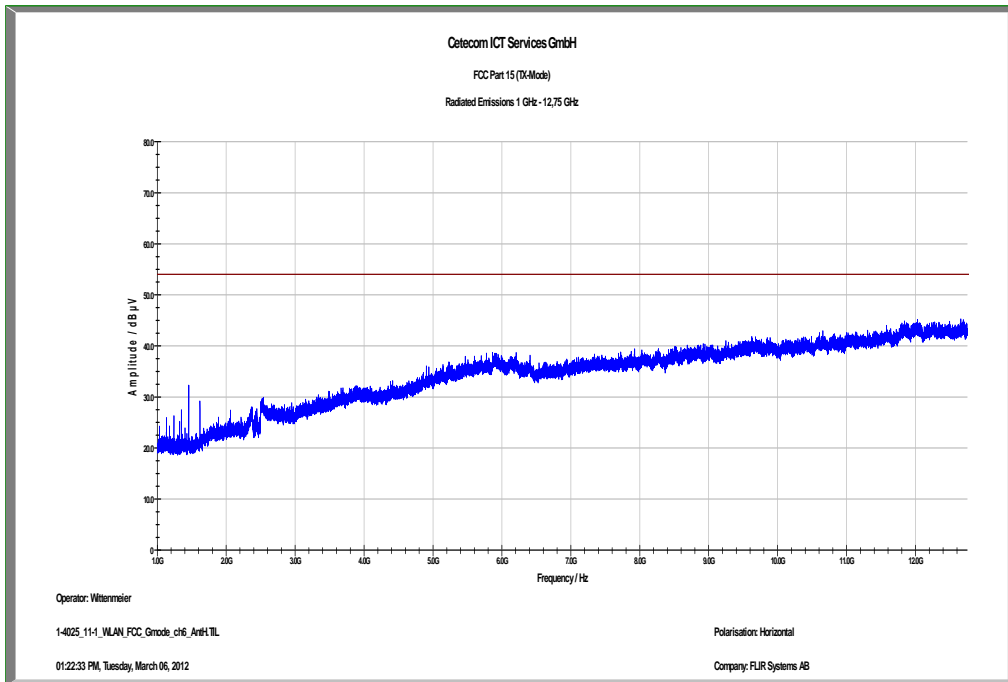

The carrier signal is notched with a 2.4 GHz band rejection filter.

Plot 9: Middle channel, 12.75 GHz to 18 GHz, vertical & horizontal polarization

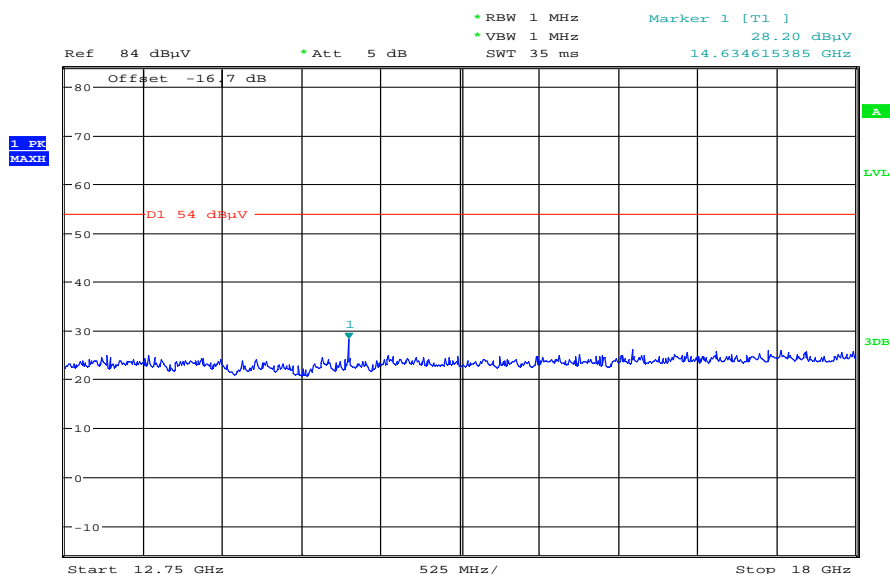

Date: 28.JUN.2012 12:58:45

Plot 10: Middle channel, 18 GHz to 26 GHz, vertical & horizontal polarization

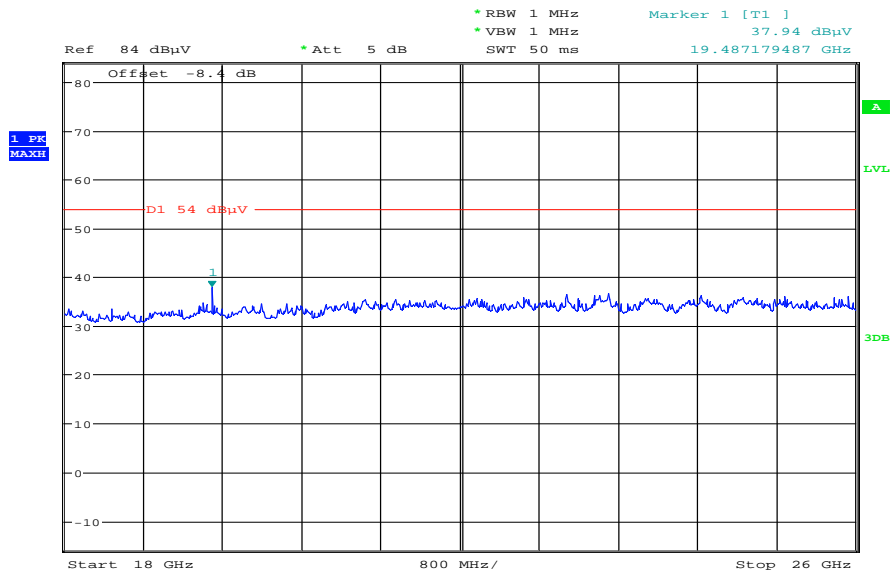

Date: 28.JUN.2012 13:02:02

Plot 11: Highest channel, 30 MHz to 1 GHz, vertical & horizontal polarization

Common Information

EUT: T4xx Core (T198200)
 Serial Number: 62000140
 Test Description: FCC part 15 class B @ 10 m
 Operating Conditions: WLAN g-mode TX Ch. 11 + charging
 Operator Name: Hennemann
 Comment: AC: 115 V / 60 Hz

Scan Setup: STAN_Fin [EMI radiated]

Hardware Setup: Electric Field (NOS)
 Receiver: [ESCI 3]
 Level Unit: dBµV/m
Subrange **Step Size** **Detectors** **IF BW** **Meas. Time** **Preamp**
 30 MHz - 2 GHz 60 kHz QPK 120 kHz 1 s 20 dB

FCC_10m(B)_3

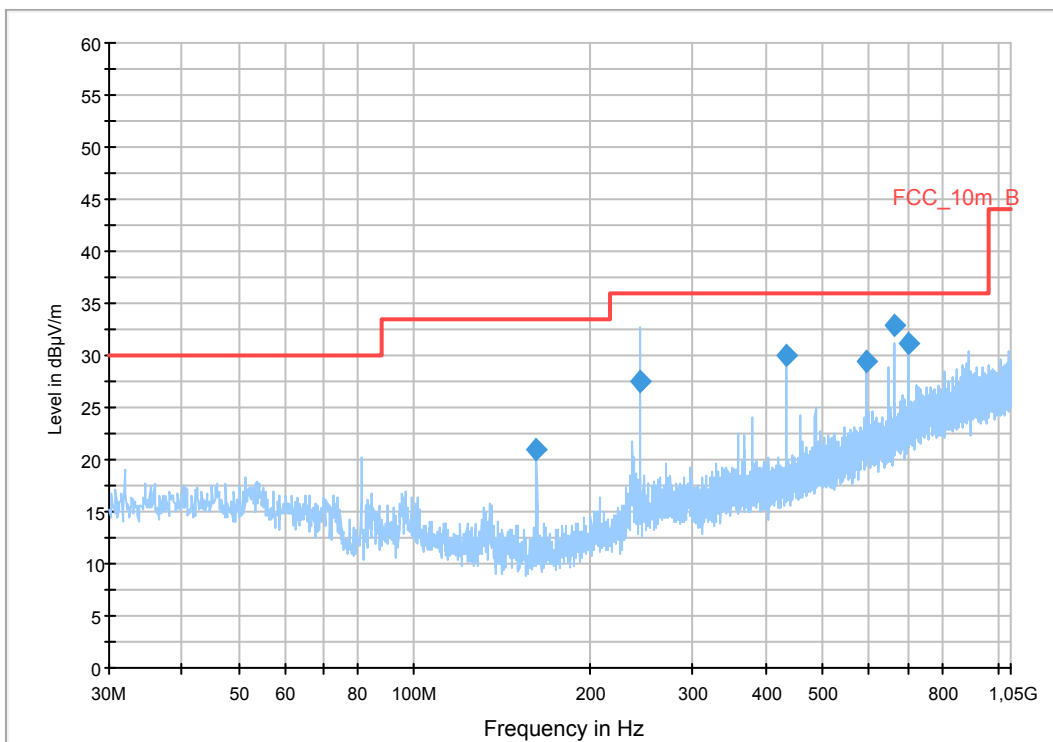

Final Result 1

Frequency (MHz)	QuasiPeak (dBµV/m)	Meas. Time (ms)	Bandwidth (kHz)	Height (cm)	Polarization	Azimuth (deg)	Corr. (dB)	Margin (dB)	Limit (dBµV/m)	Comment
162.016800	21.0	1000.0	120.000	106.0	V	106.0	9.3	12.5	33.5	
243.050550	27.5	1000.0	120.000	114.0	V	-7.0	13.1	8.5	36.0	
432.009900	30.0	1000.0	120.000	170.0	H	-6.0	17.4	6.0	36.0	
594.024600	29.5	1000.0	120.000	170.0	H	283.0	20.6	6.5	36.0	
662.820450	32.9	1000.0	120.000	170.0	H	-7.0	21.5	3.1	36.0	
702.006150	31.1	1000.0	120.000	156.0	H	-7.0	22.5	4.9	36.0	

Plot 12: Highest channel, 1 GHz to 12.75 GHz, vertical polarization

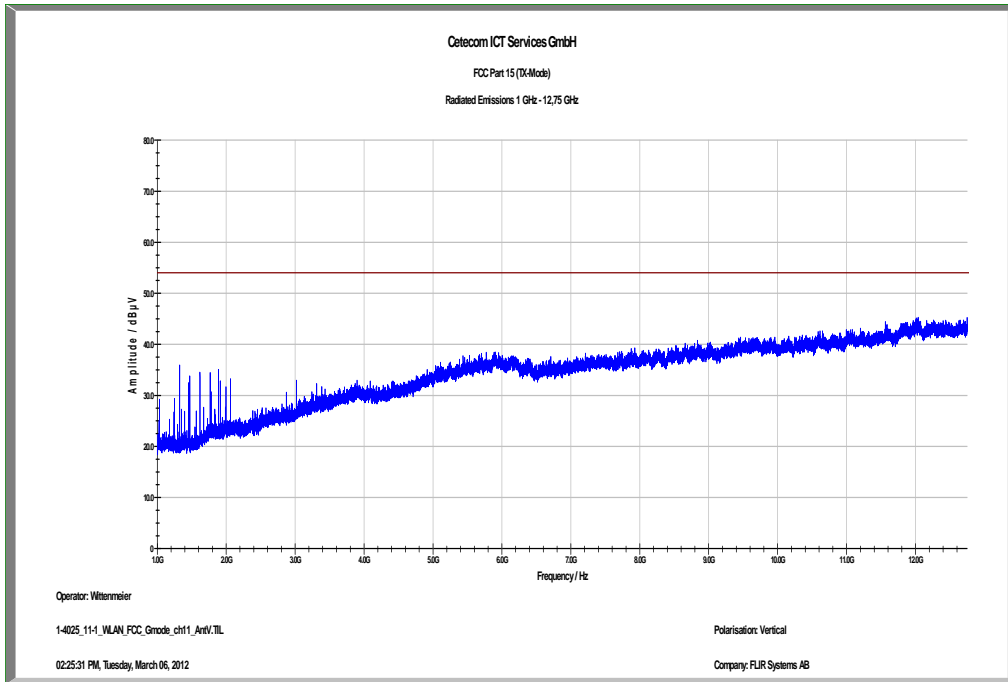

The carrier signal is notched with a 2.4 GHz band rejection filter.

Plot 13: Highest channel, 1 GHz to 12.75 GHz, horizontal polarization

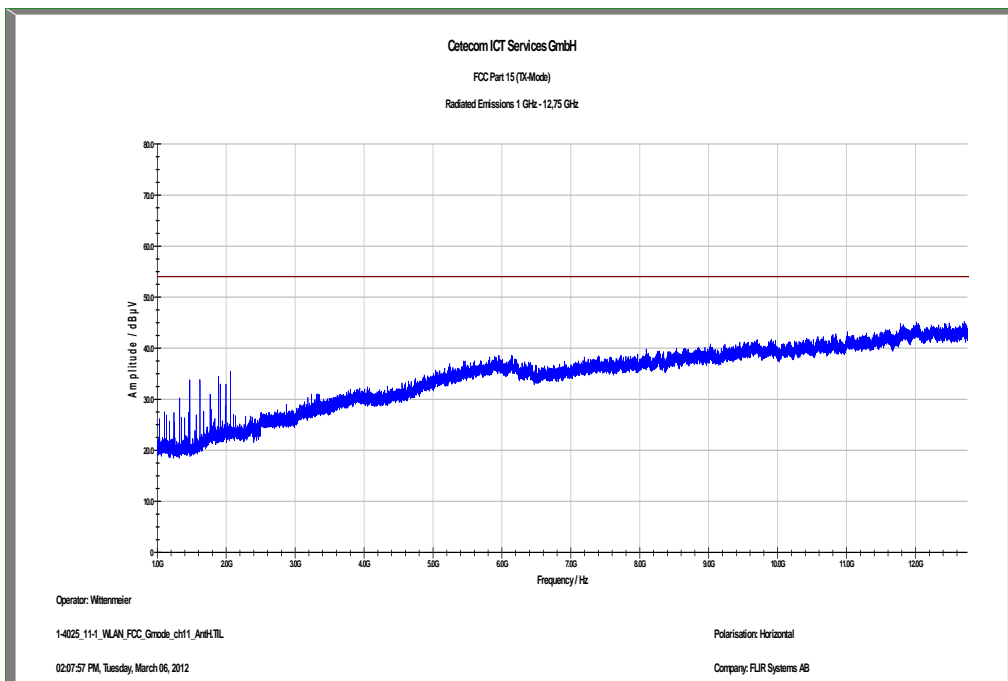

The carrier signal is notched with a 2.4 GHz band rejection filter.

Plot 14: Highest channel, 12.75 GHz to 18 GHz, vertical & horizontal polarization

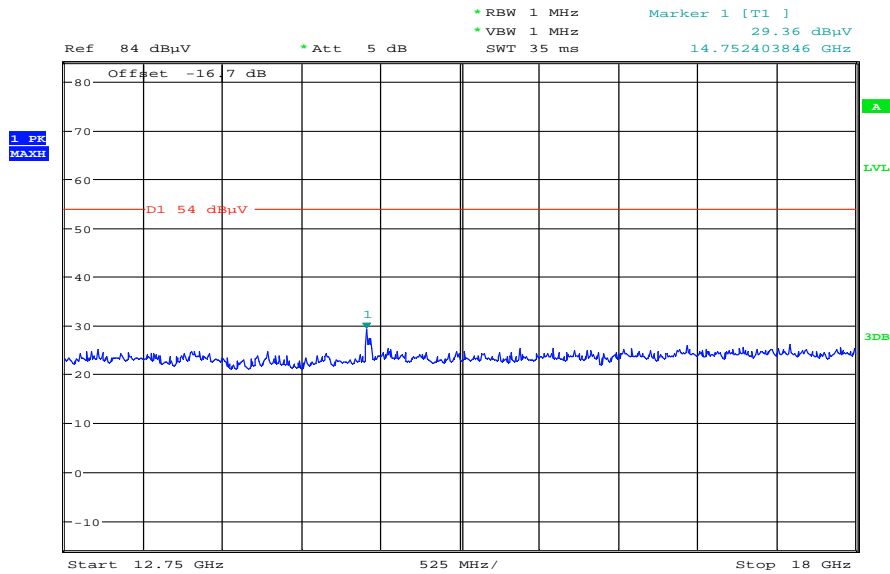

Date: 28.JUN.2012 12:59:35

Plot 15: Highest channel, 18 GHz to 26 GHz, vertical & horizontal polarization

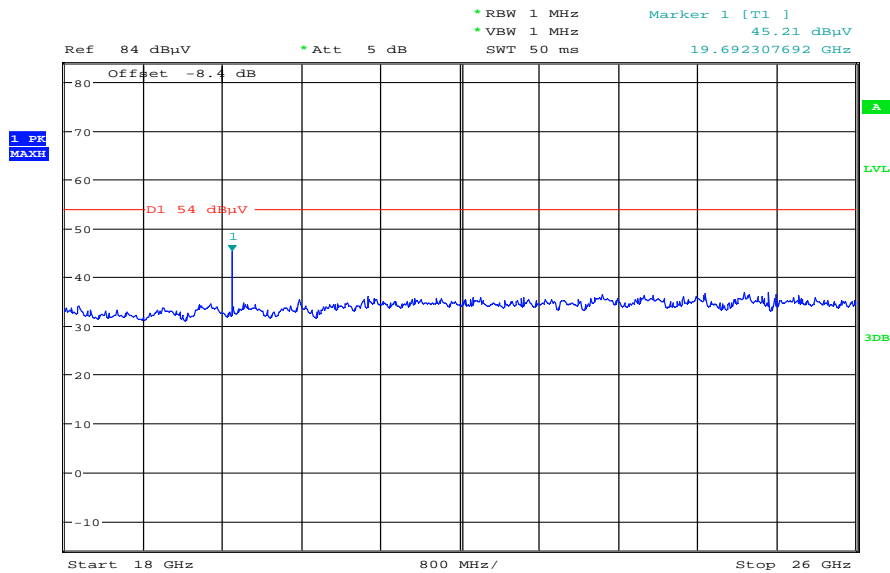

Date: 28.JUN.2012 13:01:26

9.11 RX spurious emissions radiated

Description:

Measurement of the radiated spurious emissions in idle/receive mode. The results are valid for both modes.

Measurement:

Measurement parameter	
Detector:	Peak / Quasi Peak / RMS
Sweep time:	Auto
Resolution bandwidth:	F > 1 GHz: 1 MHz F < 1 GHz: 100 kHz
Video bandwidth:	Sweep: 100 kHz Remeasurement: 10 Hz / 3 MHz
Span:	30 MHz to 25 GHz
Trace-Mode:	Max Hold

Limits:

FCC		IC
RX Spurious Emissions Radiated		
Frequency (MHz)	Field Strength (dBµV/m)	Measurement distance
30 - 88	30.0	10
88 – 216	33.5	10
216 – 960	36.0	10
Above 960	54.0	3

Results:

RX Spurious Emissions Radiated [dBµV/m]		
F [MHz]	Detector	Level [dBµV/m]
For emissions below 1 GHz, please take a look at the table below the 1 GHz plot.		
1300	Peak	42.92
Measurement uncertainty	± 3 dB	

Result: Passed.

Plots: RX / Idle – mode

Plot 1: 30 MHz to 1 GHz, vertical & horizontal polarization

Common Information

EUT: T4xx Core (T198200)
 Serial Number: 62000140
 Test Description: FCC part 15 class B @ 10 m
 Operating Conditions: WLAN RX + charging
 Operator Name: Hennemann
 Comment: AC: 115 V / 60 Hz

Scan Setup: STAN_Fin [EMI radiated]

Hardware Setup: Electric Field (NOS)
 Receiver: [ESCI 3]
 Level Unit: dBµV/m

Subrange	Step Size	Detectors	IF BW	Meas. Time	Preamp
30 MHz - 2 GHz	60 kHz	QPK	120 kHz	1 s	20 dB

FCC_10m(B)_3

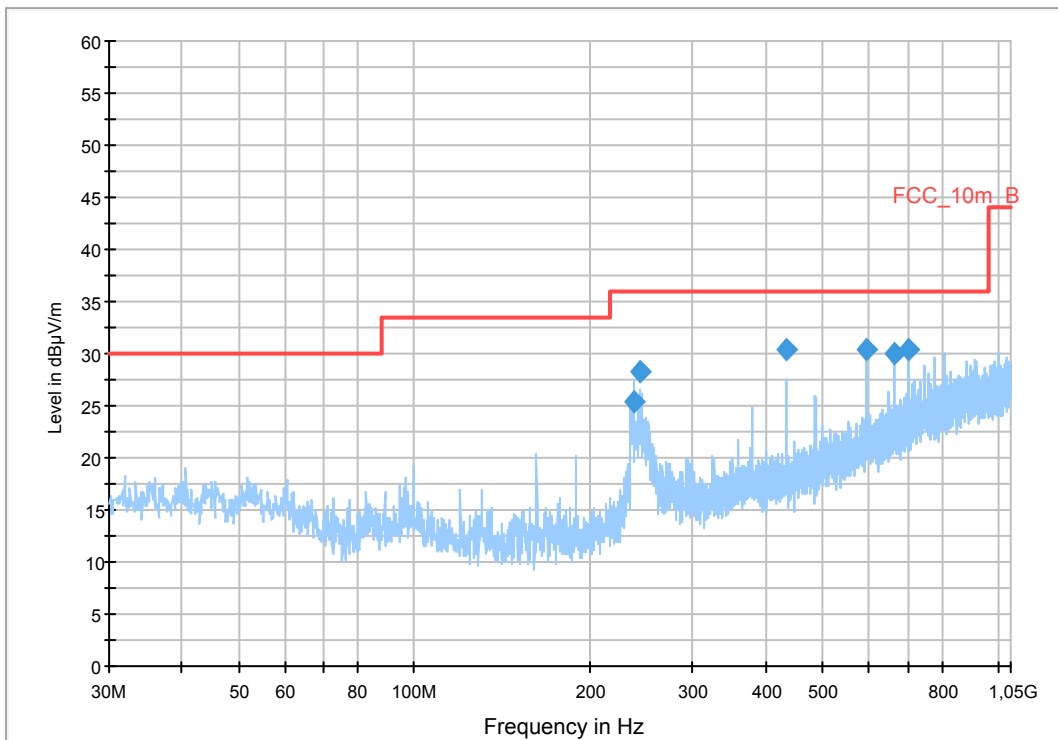

Final Result 1

Frequency (MHz)	QuasiPeak (dBµV/m)	Meas. Time (ms)	Bandwidth (kHz)	Height (cm)	Polarization	Azimuth (deg)	Corr. (dB)	Margin (dB)	Limit (dBµV/m)	Comment
237.290850	25.3	1000.0	120.000	132.0	V	178.0	12.9	10.7	36.0	
242.964300	28.3	1000.0	120.000	98.0	V	196.0	13.1	7.7	36.0	
431.995200	30.5	1000.0	120.000	170.0	H	8.0	17.4	5.5	36.0	
593.998800	30.3	1000.0	120.000	170.0	H	106.0	20.6	5.7	36.0	
662.781600	30.0	1000.0	120.000	170.0	H	196.0	21.5	6.0	36.0	
701.979150	30.4	1000.0	120.000	135.0	H	-5.0	22.5	5.6	36.0	

Plot 2: 1 GHz to 12.75 GHz, vertical polarization

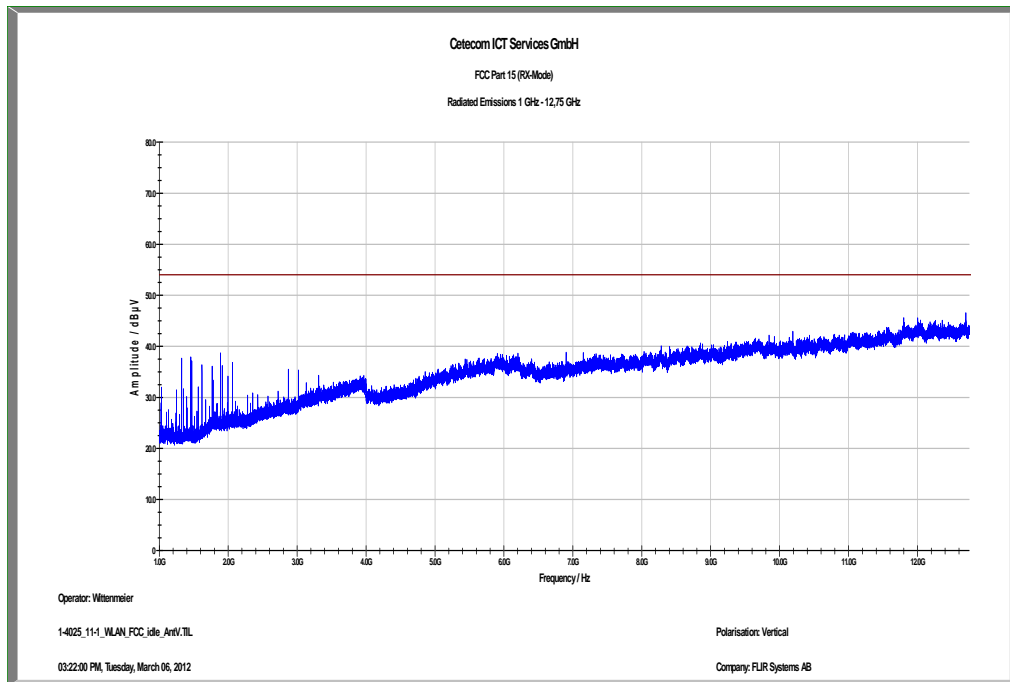

Plot 3: 1 GHz to 12.75 GHz, horizontal polarization

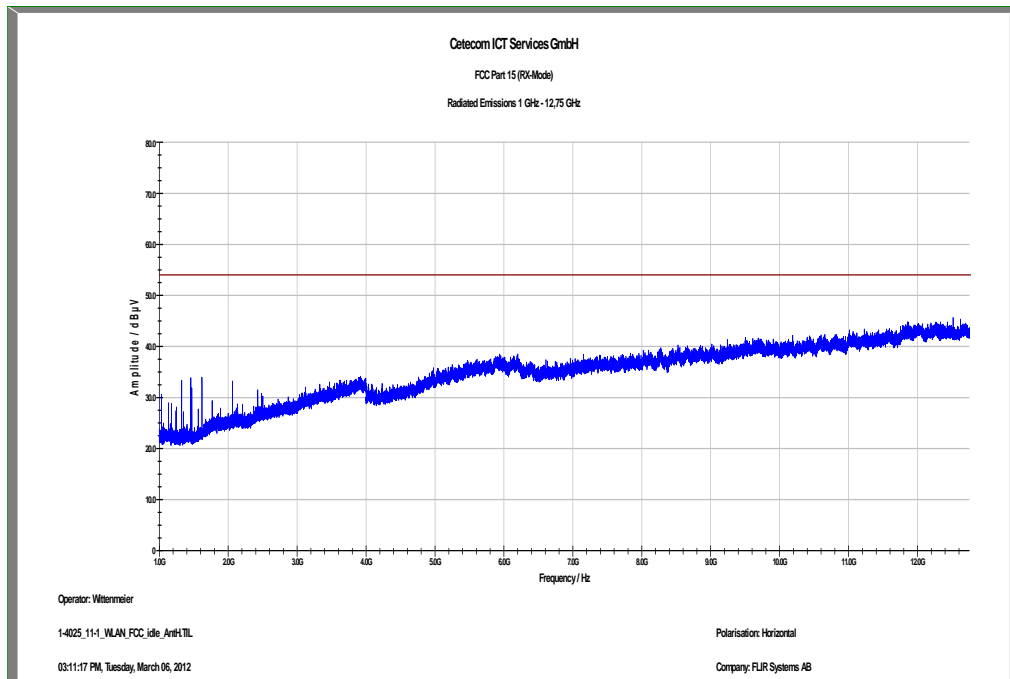

Plot 4: 12.75 GHz to 18 GHz, vertical & horizontal polarization

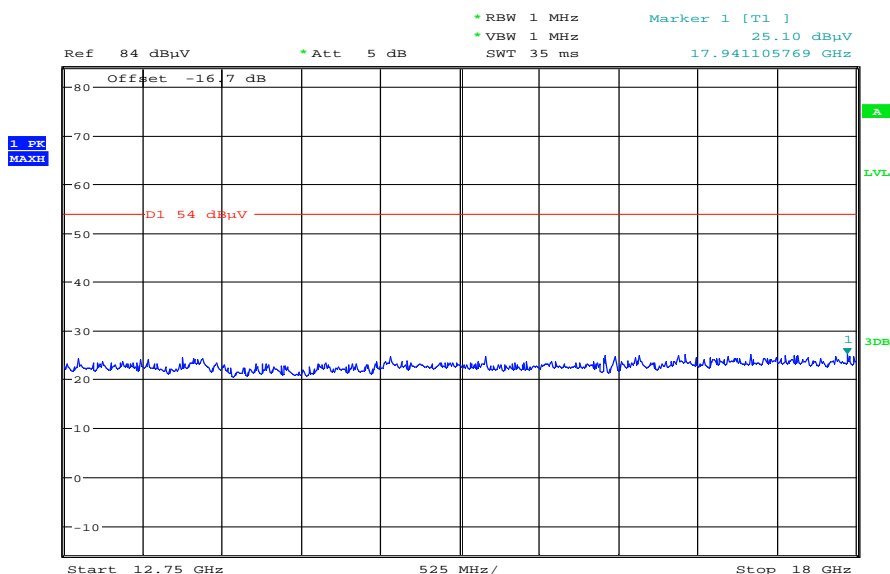

Date: 28.JUN.2012 13:20:43

Plot 5: 18 GHz to 26 GHz, vertical & horizontal polarization

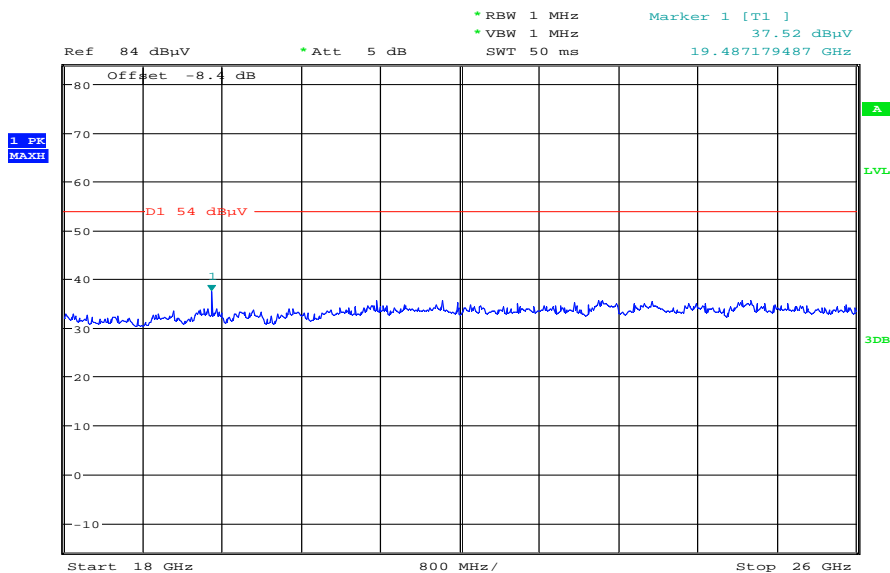

Date: 28.JUN.2012 13:22:14

9.12 Spurious emissions radiated < 30 MHz

Description:

Measurement of the radiated spurious emissions in transmit mode below 30 MHz. The EUT is set to channel 6. This measurement is representative for all channels and modes. If critical peaks are found channel 1 and channel 11 will be measured too. The measurement is performed with the data rate producing the highest output power. The limits are recalculated to a measurement distance of 3 m with 40 dB/decade according CFR Part 2.

Measurement:

Measurement parameter	
Detector:	Peak / Quasi Peak
Sweep time:	Auto
Video bandwidth:	F < 150 kHz: 200 Hz F > 150 kHz: 9 kHz
Resolution bandwidth:	F < 150 kHz: 1 kHz F > 150 kHz: 100 kHz
Span:	9 kHz to 30 MHz
Trace-Mode:	Max Hold

Limits:

FCC		IC
TX Spurious Emissions Radiated < 30 MHz		
Frequency (MHz)	Field Strength (dBµV/m)	Measurement distance
0.009 – 0.490	2400/F(kHz)	300
0.490 – 1.705	24000/F(kHz)	30
1.705 – 30.0	30	30

Results:

TX Spurious Emissions Radiated < 30 MHz [dBµV/m]		
F [MHz]	Detector	Level [dBµV/m]
No critical peaks detected. All detected peak values are below the average limits.		
Measurement uncertainty	± 3 dB	

Result: Passed

Plots: TX mode

Plot 1: 9 kHz to 30 MHz, b – mode

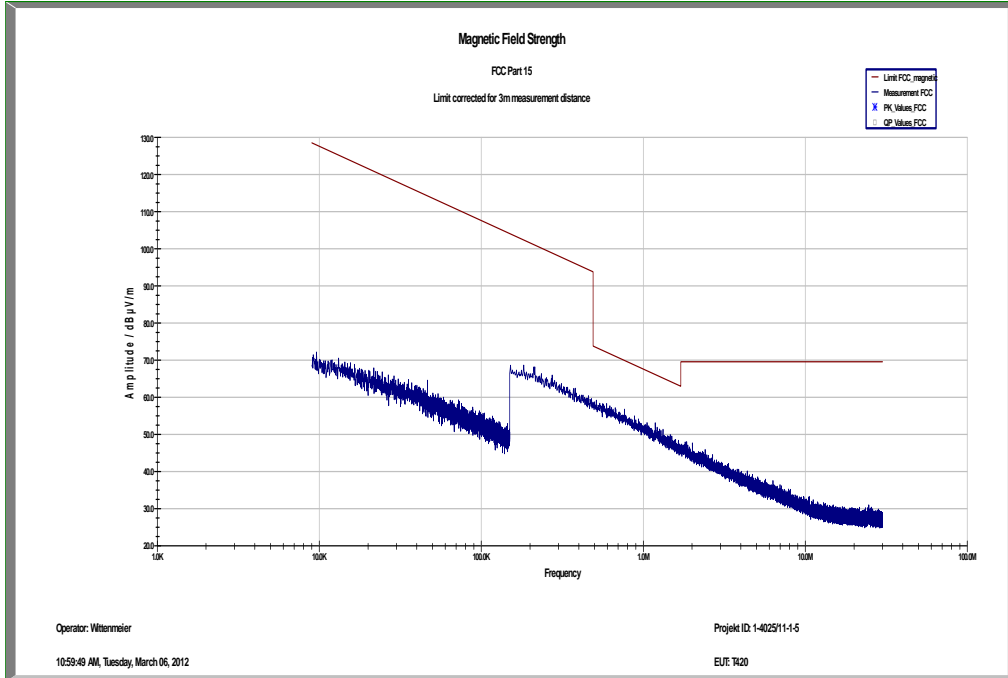

Plot 2: 9 kHz to 30 MHz, g – mode

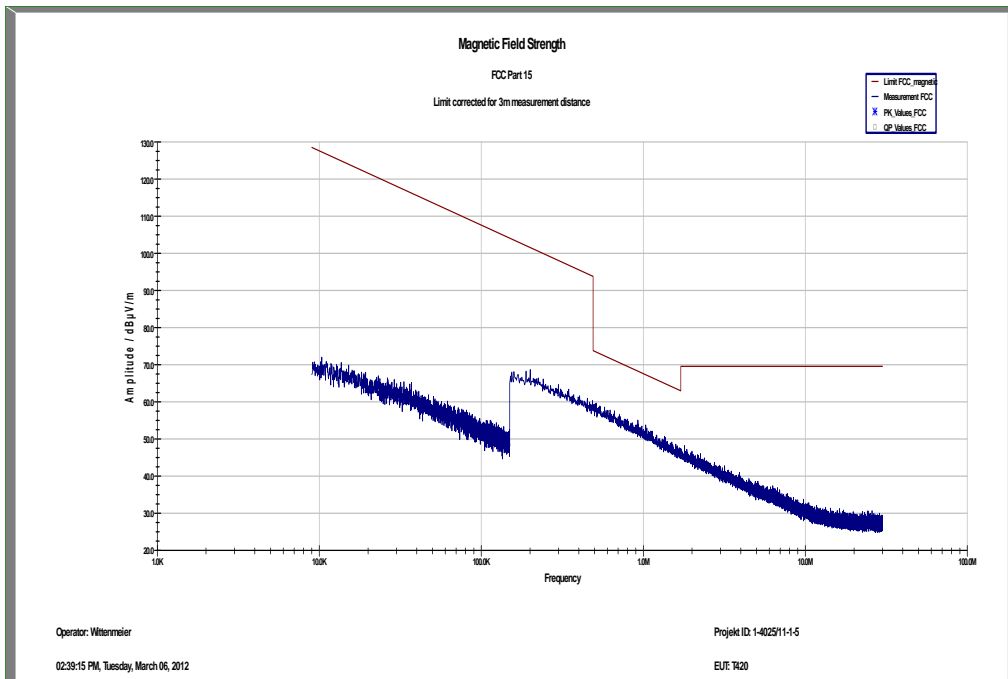

Plots: RX / Idle – mode

Plot 1: 9 kHz to 30 MHz

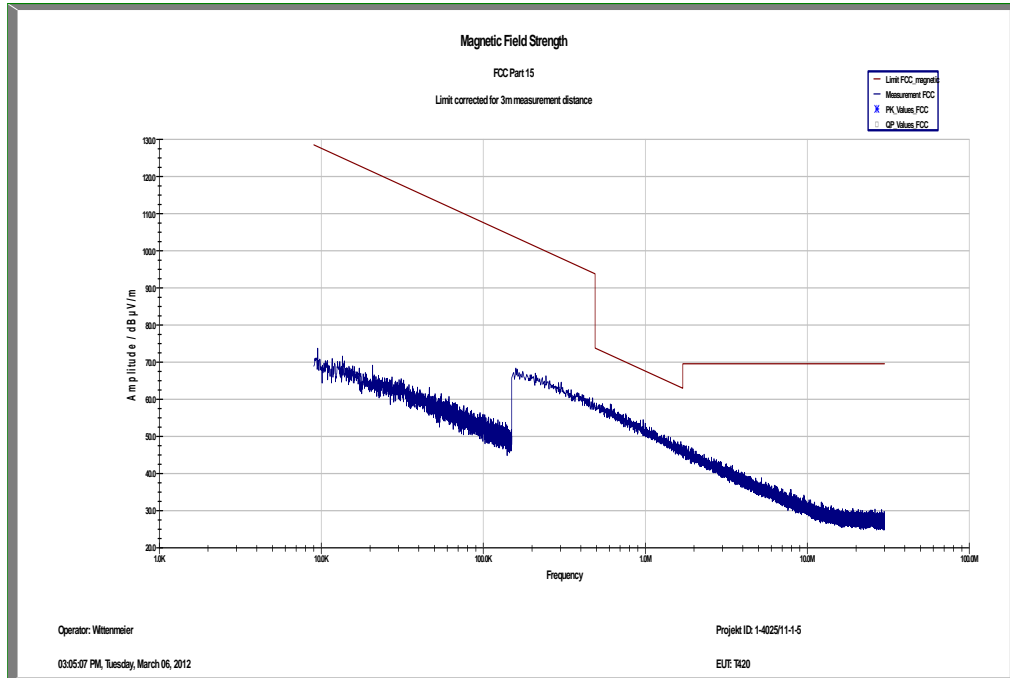

9.13 Spurious emissions conducted < 30 MHz

Description:

Measurement of the conducted spurious emissions in transmit mode below 30 MHz. The EUT is set to channel 6. This measurement is repeated for DSSS and OFDM modulation. If critical peaks are found channel 1 and channel 11 will be measured too. The measurement is performed with the data rate producing the highest output power. Both power lines, phase and neutral line, are measured. Found peaks are remeasured with average and quasi peak detection to show compliance to the limits.

Measurement:

Measurement parameter	
Detector:	Peak - Quasi Peak / Average
Sweep time:	Auto
Video bandwidth:	F < 150 kHz: 200 Hz F > 150 kHz: 9 kHz
Resolution bandwidth:	F < 150 kHz: 1 kHz F > 150 kHz: 100 kHz
Span:	9 kHz to 30 MHz
Trace-Mode:	Max Hold

Limits:

FCC		IC	
TX Spurious Emissions Conducted < 30 MHz			
Frequency (MHz)	Quasi-Peak (dBµV/m)	Average (dBµV/m)	
0.15 – 0.5	66 to 56*	56 to 46*	
0.5 – 5	56	46	
5 – 30.0	60	50	

*Decreases with the logarithm of the frequency

Results:

TX Spurious Emissions Conducted < 30 MHz [dBµV/m]		
F [MHz]	Detector	Level [dBµV/m]
No critical peaks detected. All detected peak values are below the average limits.		
Measurement uncertainty	± 3 dB	

Result: Passed

Plots:

Plot 1: TX mode, 9 kHz to 30 MHz, phase line, b – mode

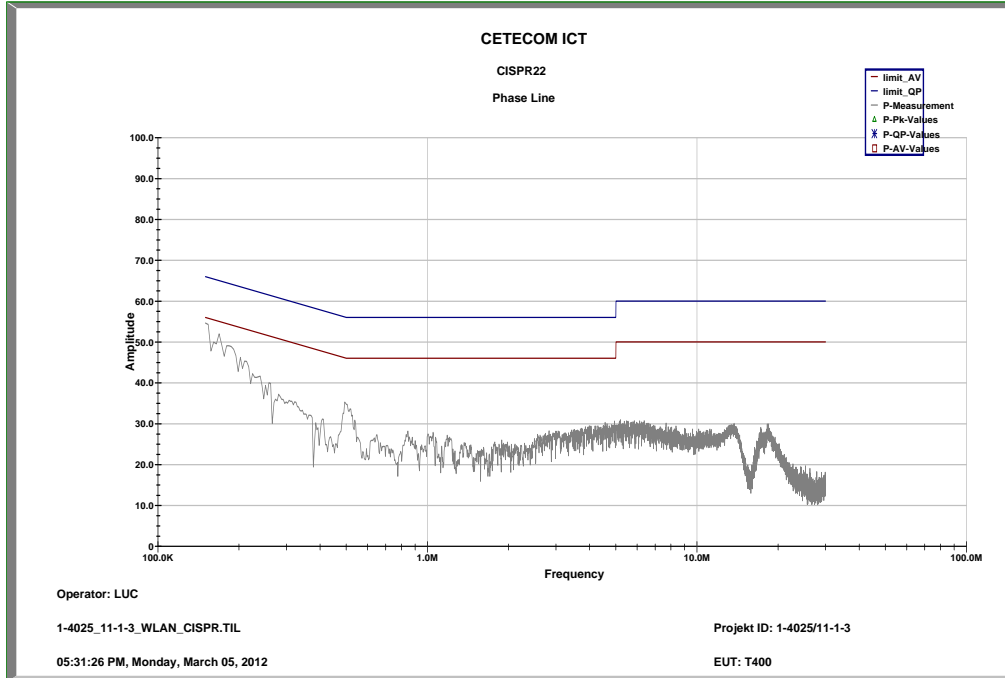

Plot 2: TX mode, 9 kHz to 30 MHz, neutral line, b – mode

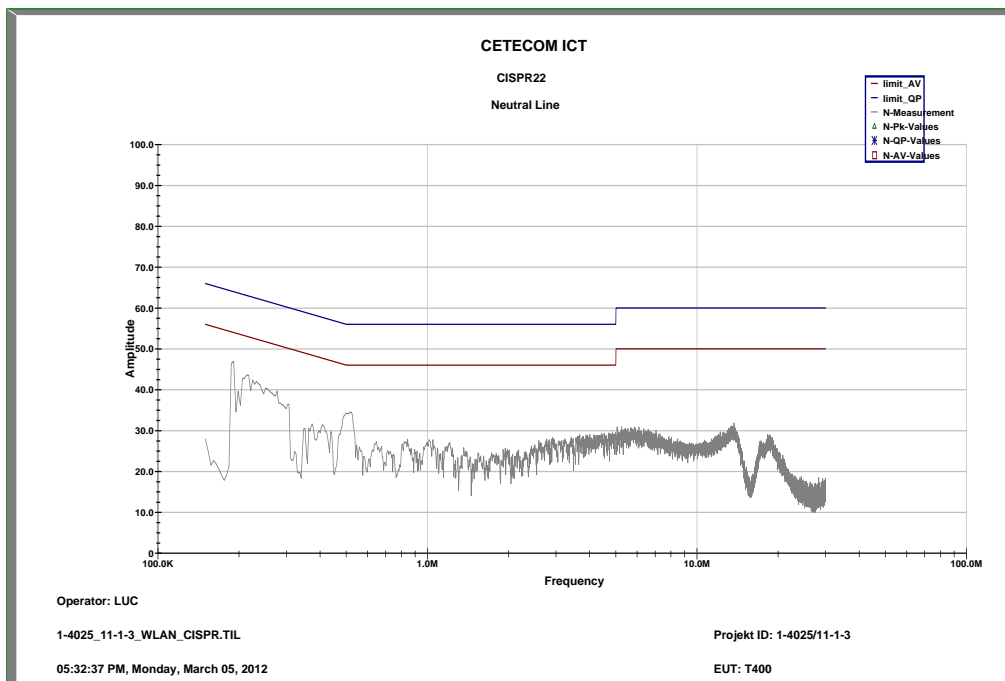

Plot 3: TX mode, 9 kHz to 30 MHz, phase line, g – mode

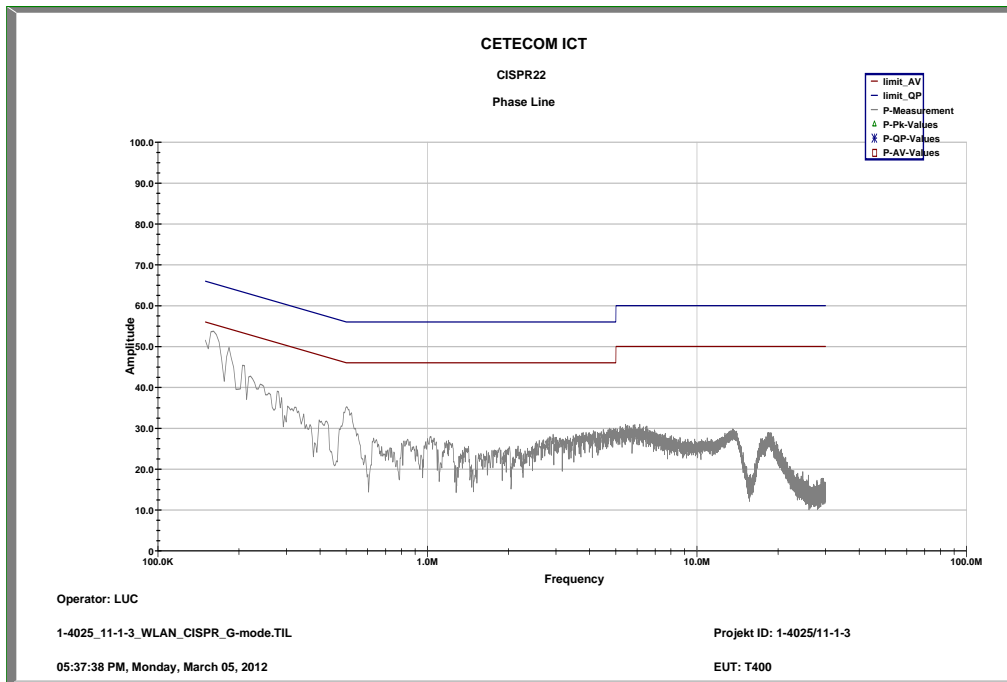

Plot 4: TX mode, 9 kHz to 30 MHz, neutral line, g – mode

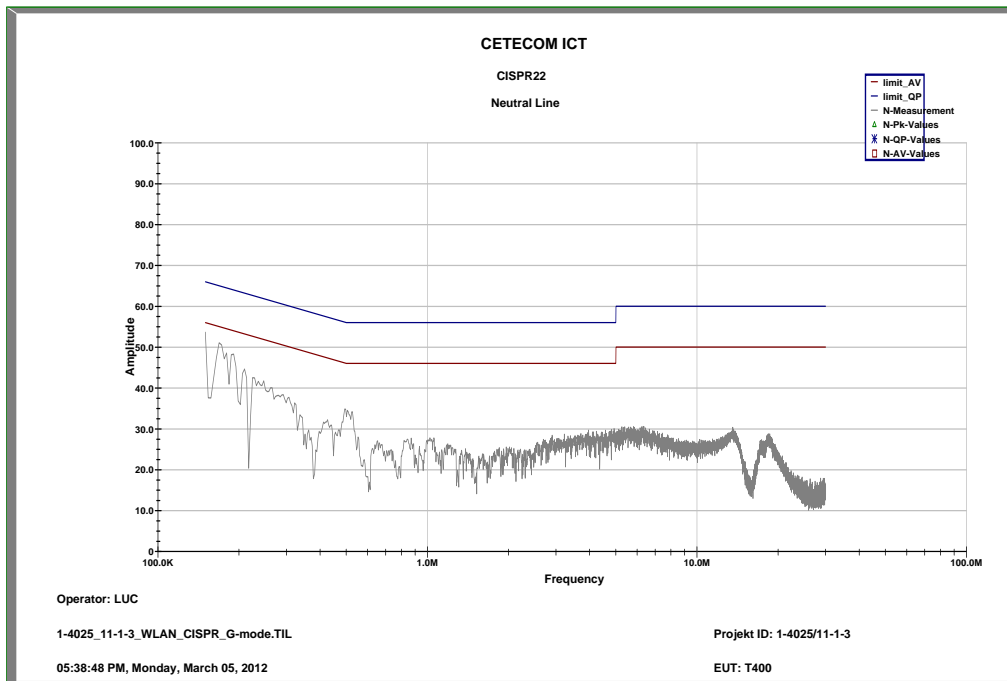

Plot 5: RX / Idle – mode, 9 kHz to 30 MHz, phase line

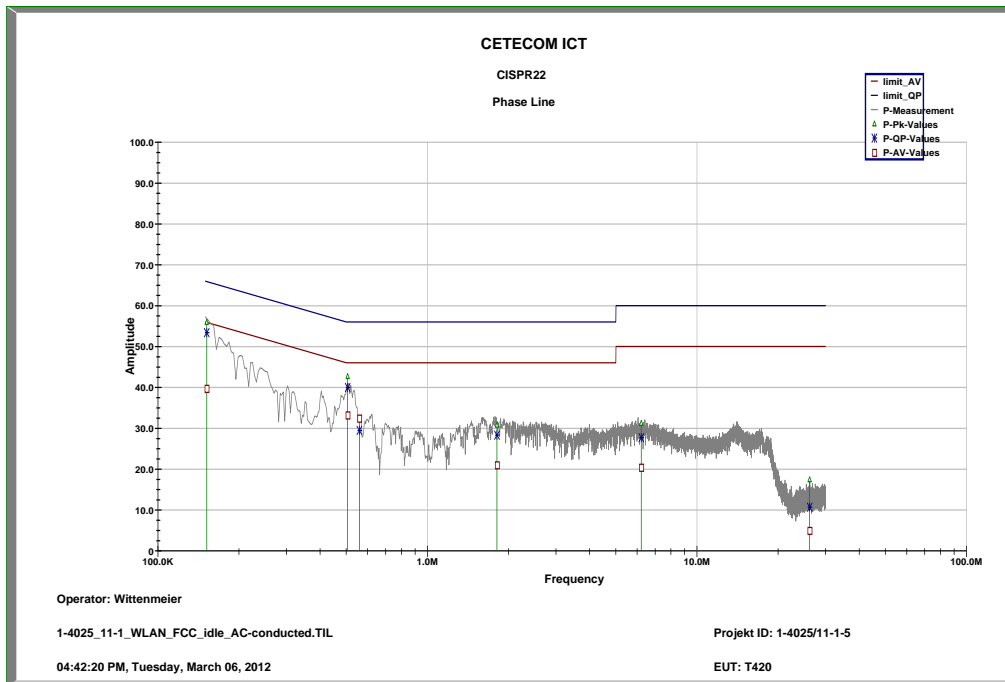

Plot 6: RX / Idle – mode, 9 kHz to 30 MHz, neutral line

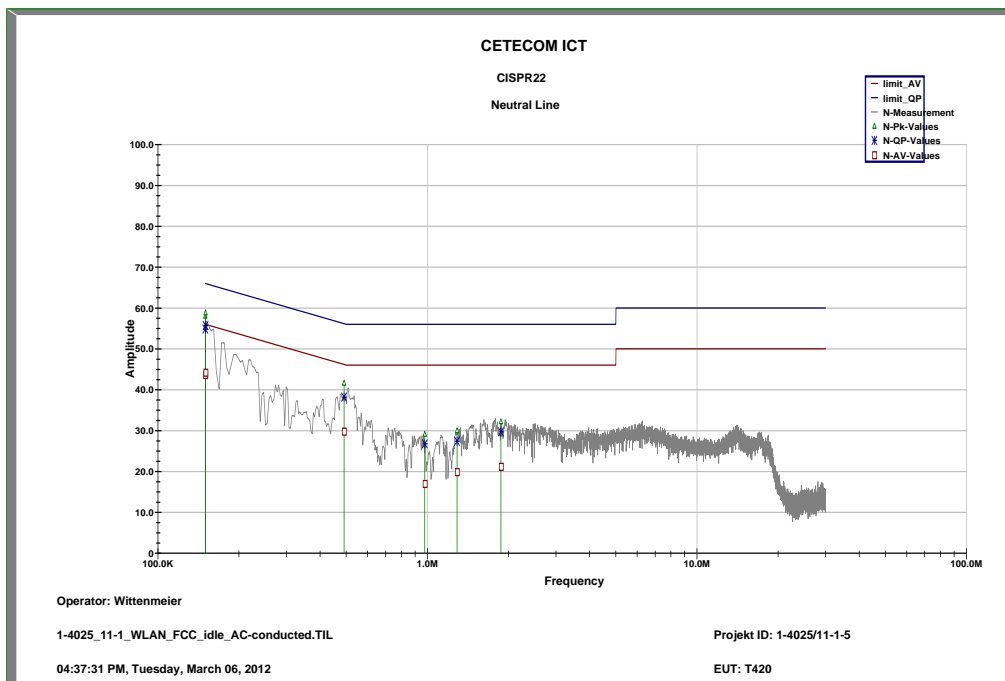

10 Test equipment and ancillaries used for tests

Typically, the calibrations of the test apparatus are commissioned to and performed by an accredited calibration laboratory. The calibration intervals are determined in accordance with the DIN EN ISO/IEC 17025. In addition to the external calibrations, the laboratory executes comparison measurements with other calibrated test systems or effective verifications. Weekly chamber inspections and range calibrations are performed. Where possible, rf-generating and signalling equipment as well as measuring receivers and analyzers are connected to an external high-precision 10 MHz reference (GPS-based or rubidium frequency standard).

In order to simplify the identification of the equipment used at some special tests, some items of test equipment and ancillaries can be provided with an identifier or number in the equipment list below (Labor/Item).

No.	Lab / Item	Equipment	Type	Manufact.	Serial No.	INV. No Cetecom	Kind of Calibration	Last Calibration	Next Calibration
1	n. a.	Temperature Test Chamber	VT 4002	Heraeus Voetsch	521/83761	300002326	Ve	20.09.2011	20.09.2013
2	n. a.	Spectrum Analyzer 20 Hz - 50 GHz	F5U50	R&S	200012	300003443	ve	01.07.2010	01.07.2012
3	n. a.	Double-Ridged Waveguide Horn Antenna 1-18.0GHz	3115	EMCO	8812-3088	300001032	vKI!	11.05.2011	11.05.2013
4	n. a.	Active Loop Antenna	6502	EMCO	2210	300001015	ne		
5	n. a.	Anechoic chamber	FAC 3/5m	MWB / TDK	87400/02	300000996	ev		
6	n. a.	Relais Matrix	3488A	HP Meßtechnik	2719A15013	300001156	ne		
7	n. a.	Three-Way Power Splitter, 50 Ohm	11850C	HP Meßtechnik		300000997	ne		
8	n. a.	Switch / Control Unit	3488A	HP	2605e08770	300001443	ne		
9	n. a.	Amplifier	js42-00502650-28-5a	Parzich GMBH	928979	300003143	ne		
10	n. a.	TRIOLOG Broadband Test-Antenna 30 MHz - 3 GHz	VULB9163	Schwarzbeck	371	300003854	vKI!	14.10.2011	14.10.2014
11	n. a.	MXE EMI Receiver 20 Hz bis 26,5 GHz	N9038A	Agilent Technologies	MY51210197	300004405	k	19.12.2011	19.12.2012

Agenda: Kind of Calibration

k	calibration / calibrated	EK	limited calibration
ne	not required (k, ev, izw, zw not required)	zw	cyclical maintenance (external cyclical maintenance)
ev	periodic self verification	izw	internal cyclical maintenance
Ve	long-term stability recognized	g	blocked for accredited testing
vKI!	Attention: extended calibration interval	*	next calibration ordered / currently in progress
NK!	Attention: not calibrated		

11 Observations

No observations exceeding those reported with the single test cases have been made.

Annex A Photographs of the test setup

Photo documentation:

Photo 1:

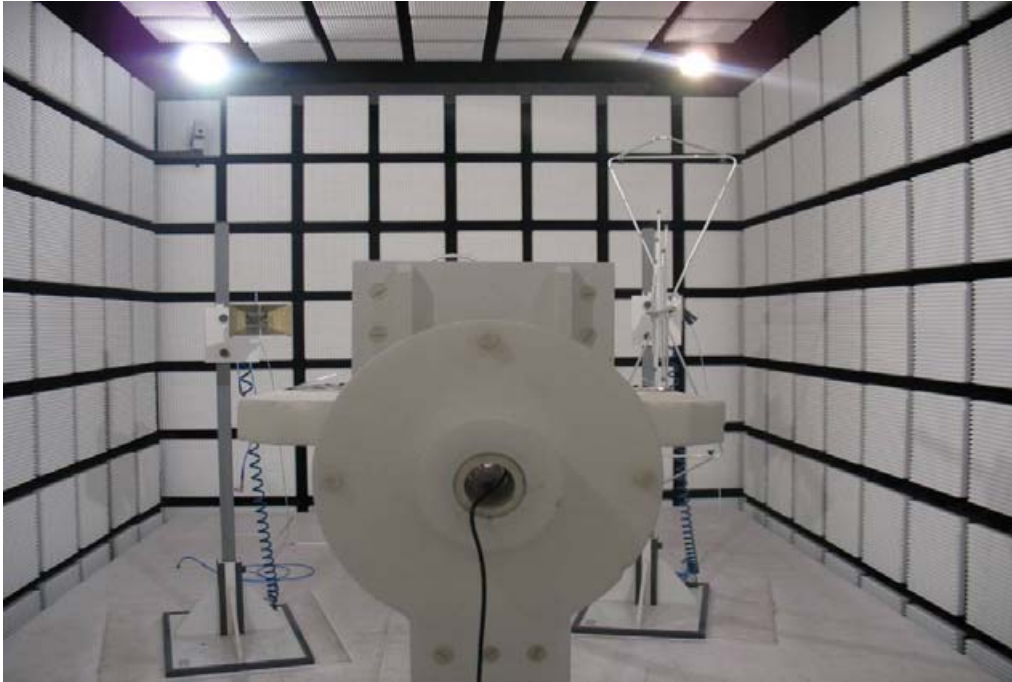

Photo 2:



Photo 3:



Photo 4:



Photo 5:

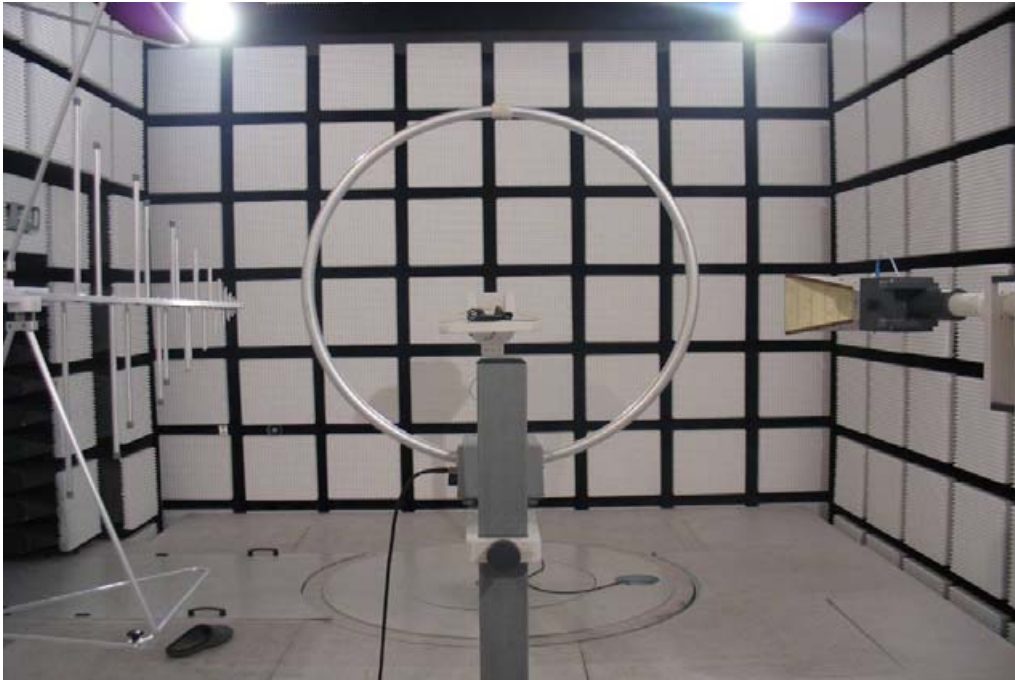

Photo 5:



Photo 6:



Photo 7:

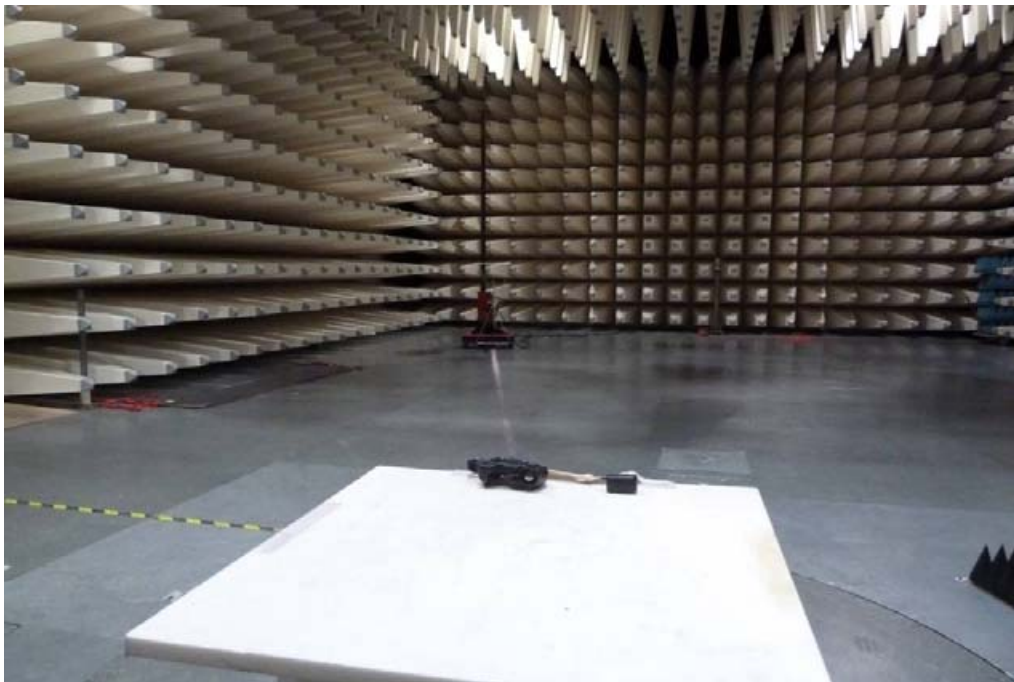

Annex B External photographs of the EUT

Photo documentation:

Photo 1:



Photo 2:



Photo 3:



Photo 4:



Photo 5:



Photo 6:



Photo 7:



Photo 8:



Photo 9:



Annex C Internal photographs of the EUT

Photo documentation:

Photo 1:



Photo 2:



Photo 3:



Photo 4:



Photo 5:

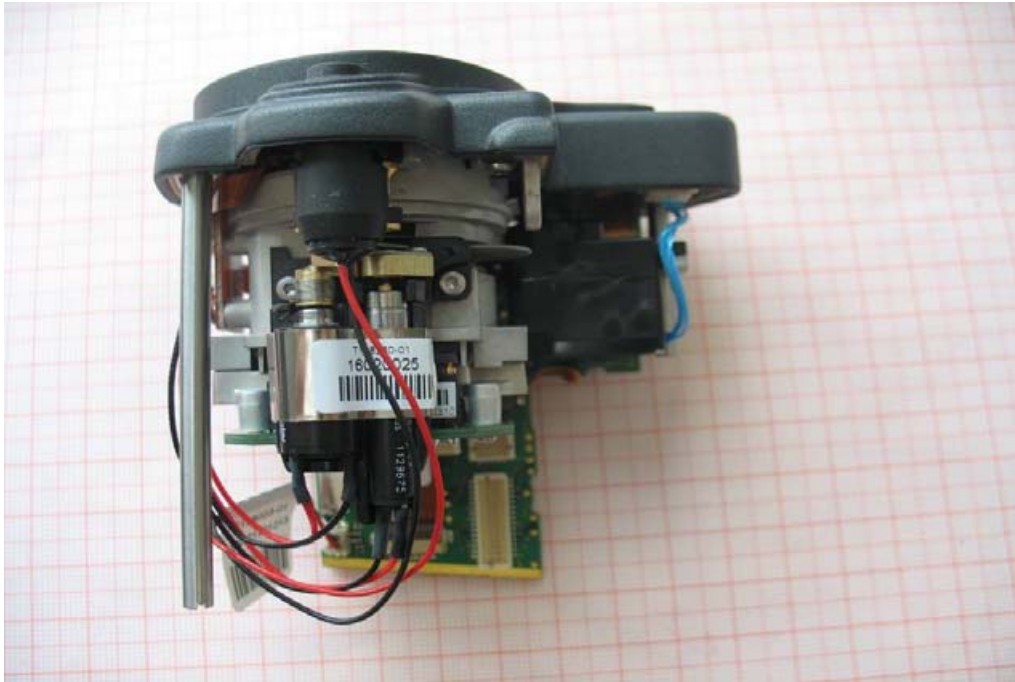

Photo 6:

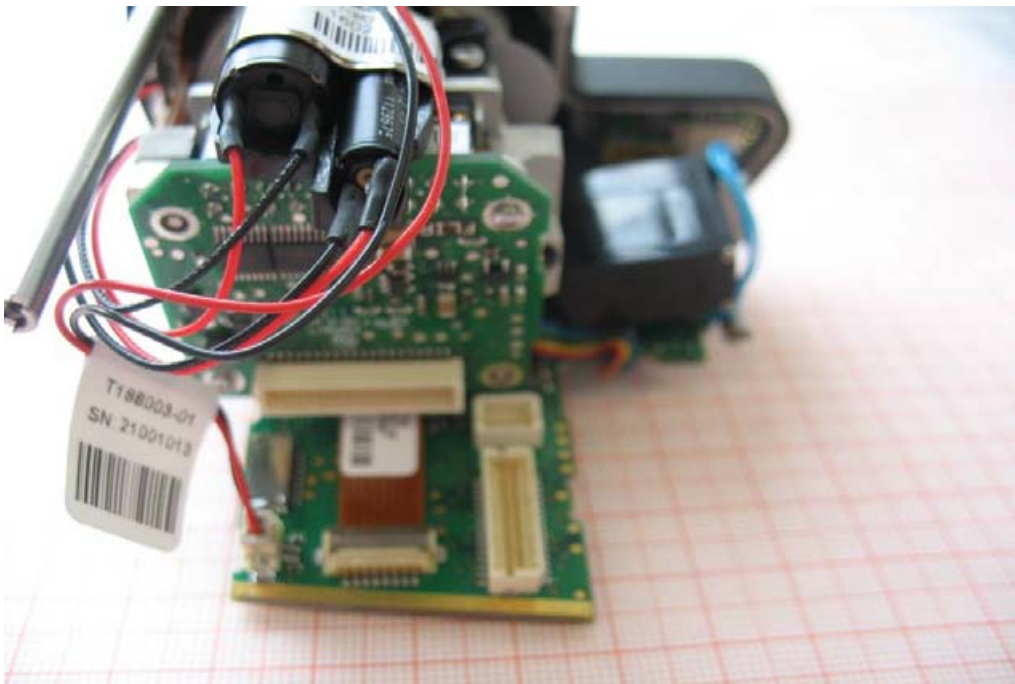

Photo 7:



Photo 8:



Photo 9:



Photo 10:



Photo 11:



Photo 12:



Photo 13:

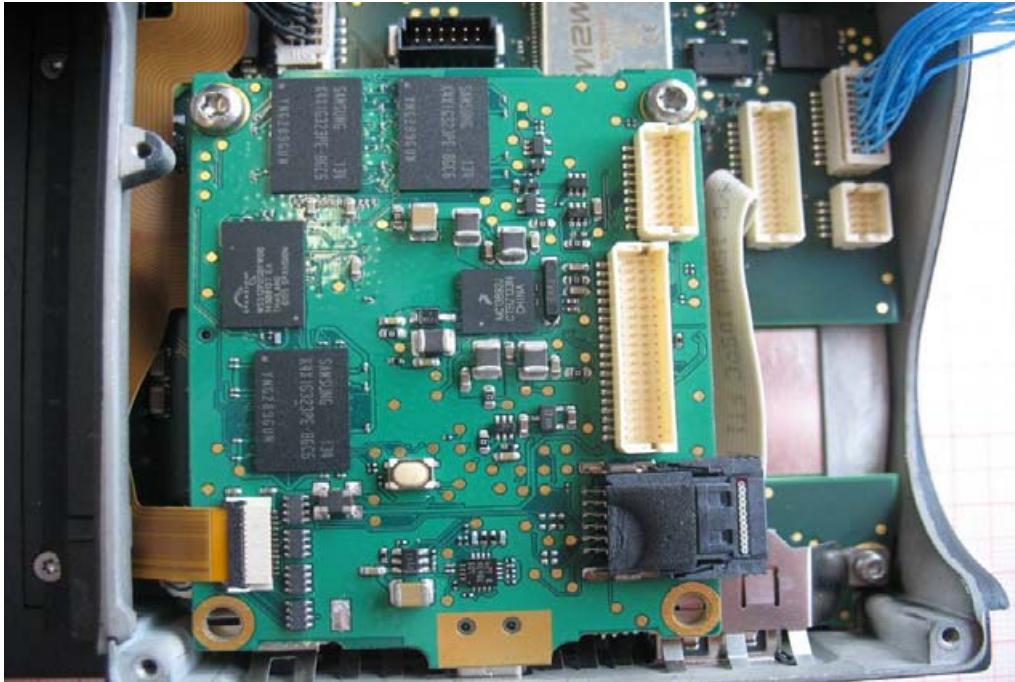

Photo 14:



Photo 15:

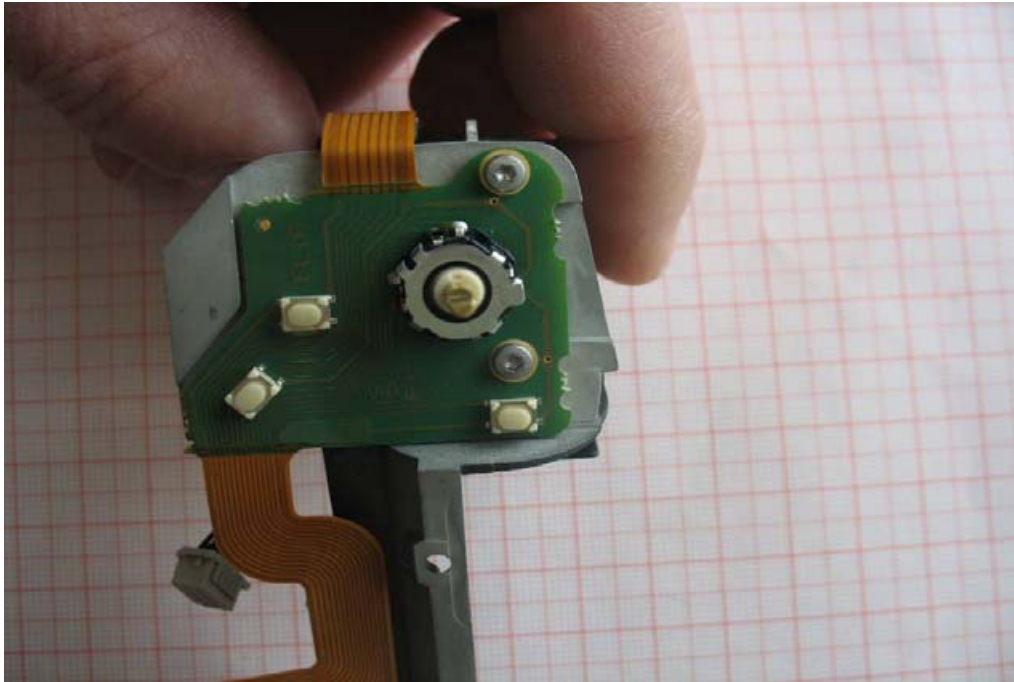

Photo 16:

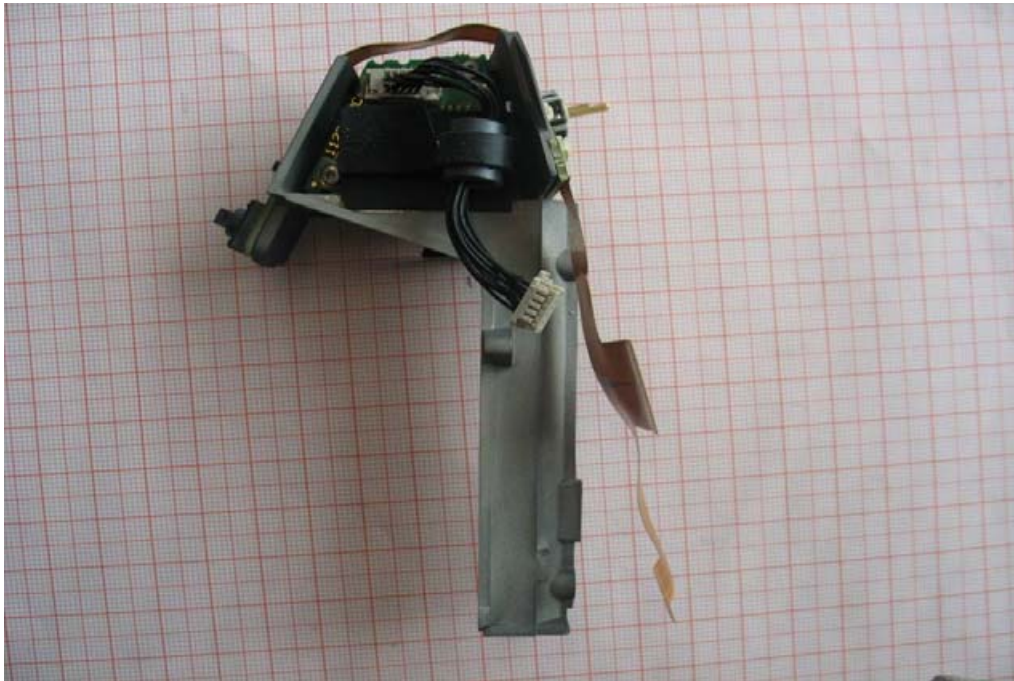

Photo 17:

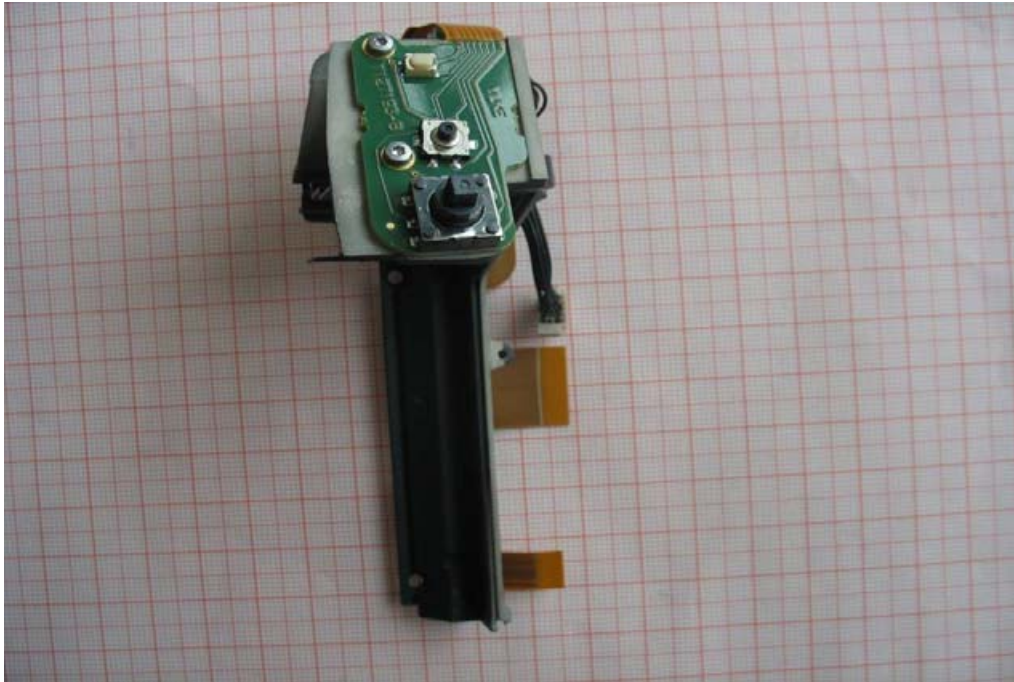

Photo 18:



Photo 19:



Photo 20:

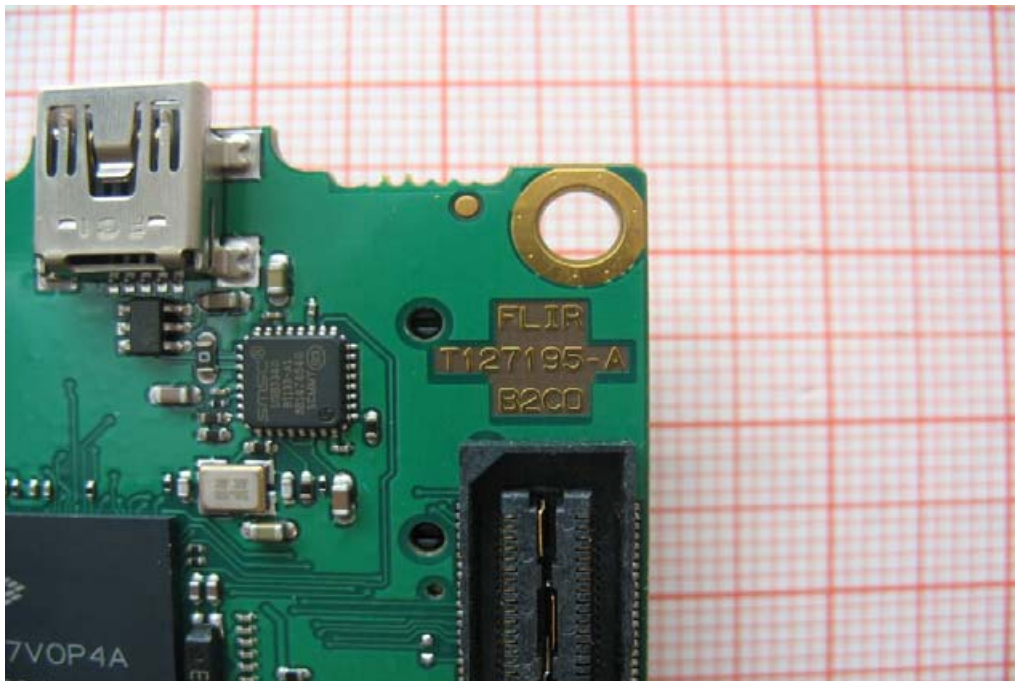

Photo 21:



Photo 22:

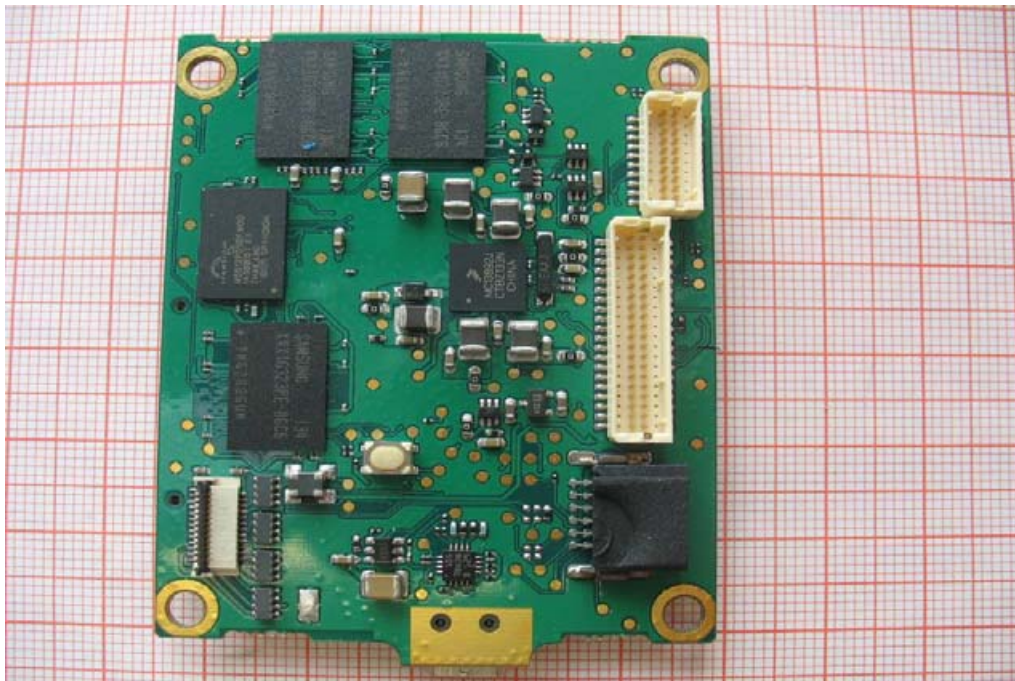

Photo 23:

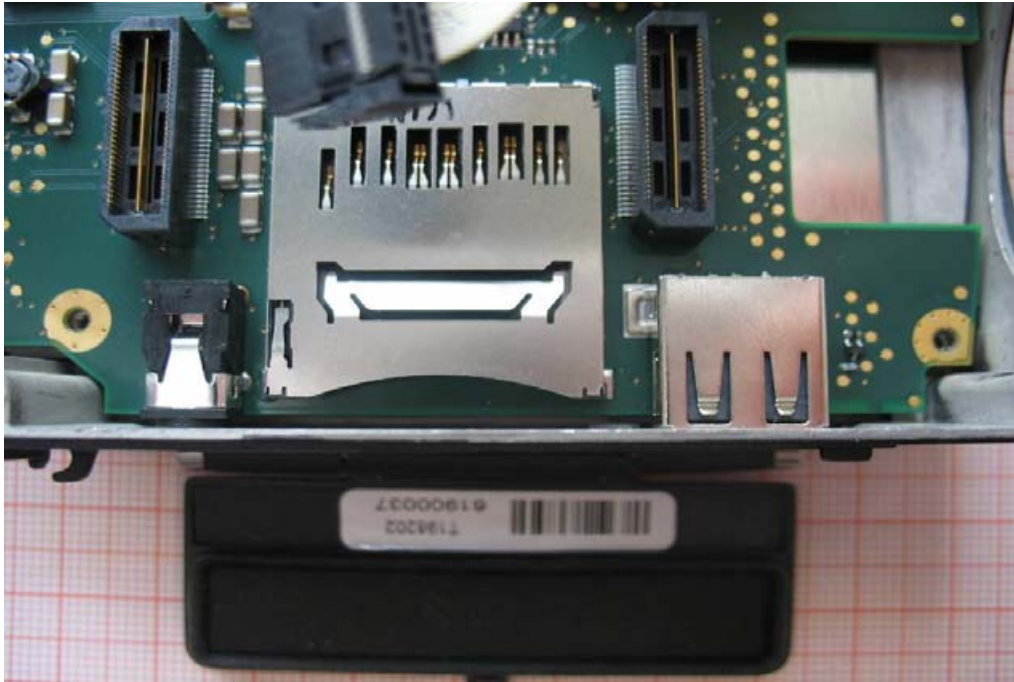

Photo 24:

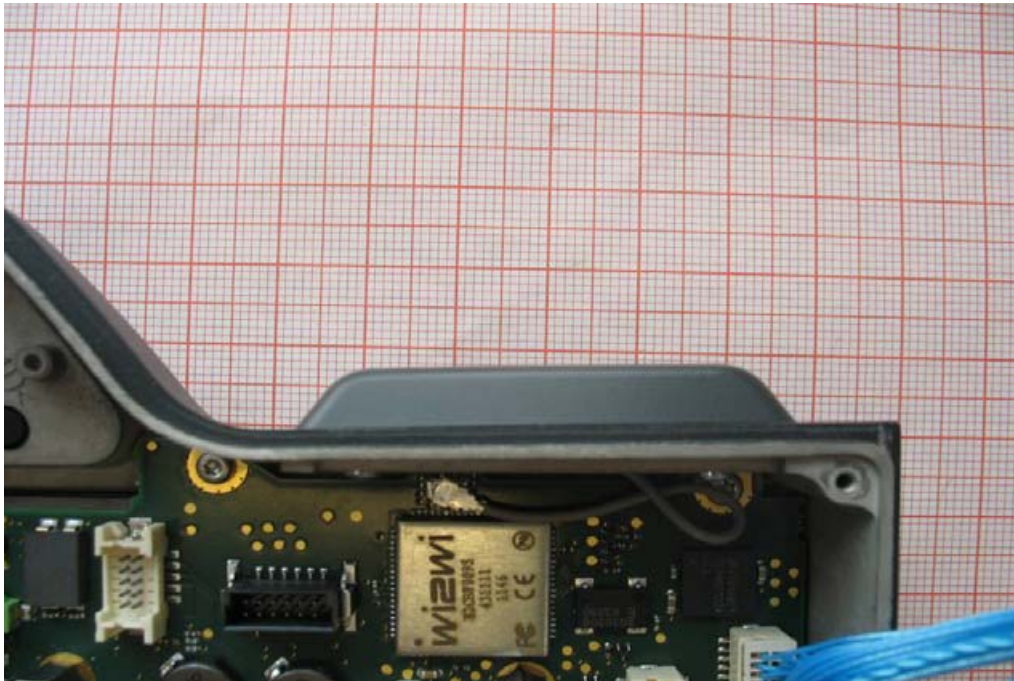

Photo 25:



Photo 26:



Photo 27:

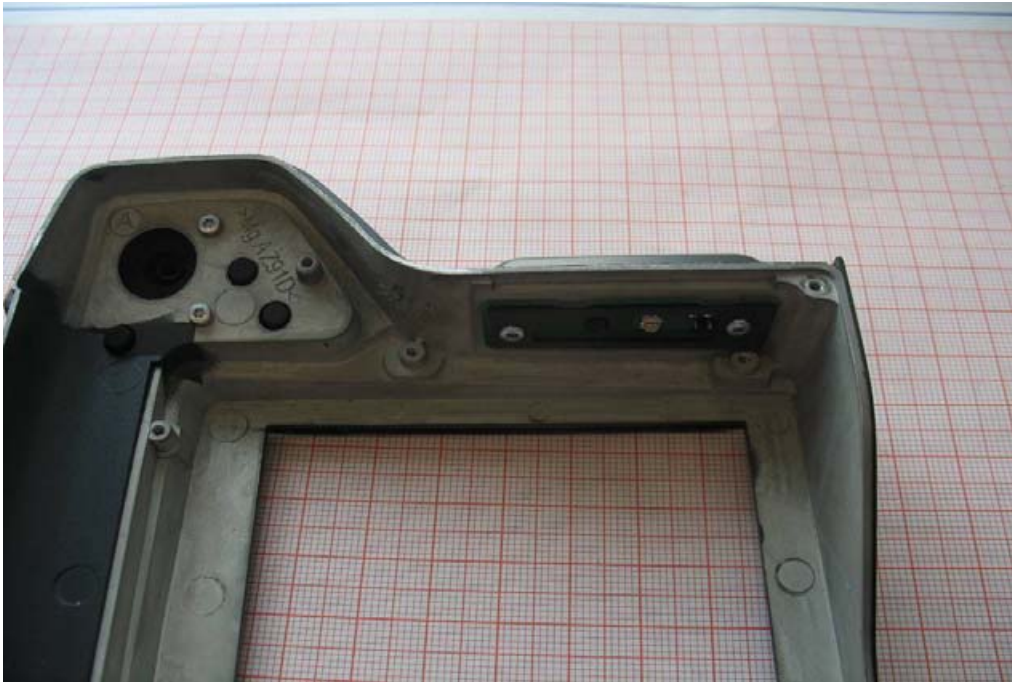

Photo 28:



Photo 29:



Photo 30:

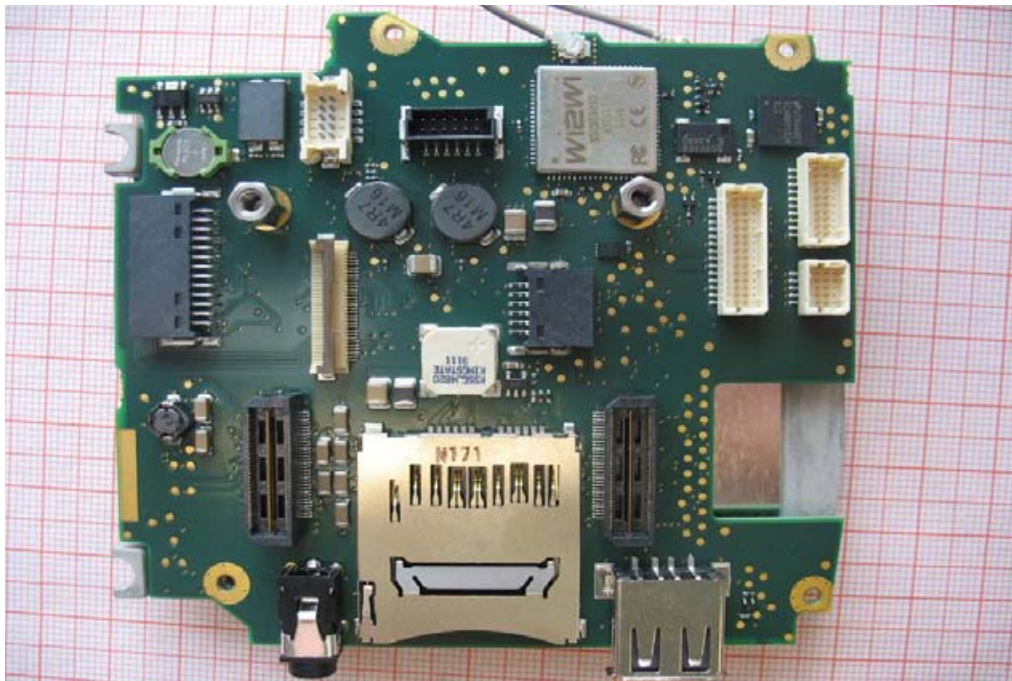

Photo 31:

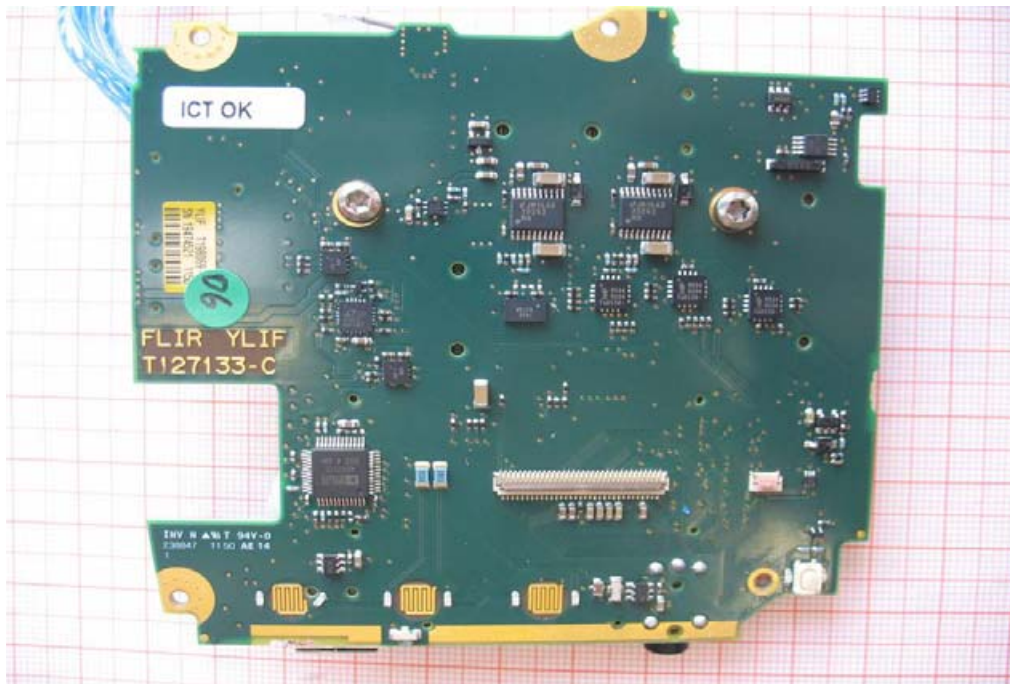

Photo 32:

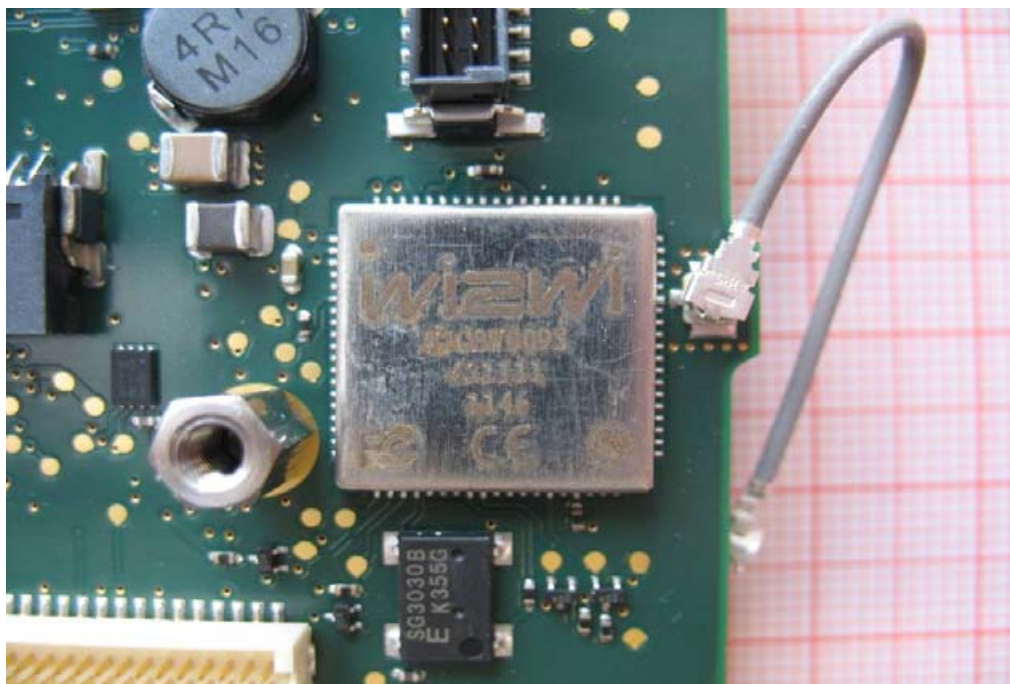

Photo 33:



Annex D Document history

Version	Applied changes	Date of release
1.0	Initial release	2012-07-02
-A	Editorial changes	2012-11-06

Annex E Further information**Glossary**

AVG	-	Average
DUT	-	Device under test
EMC	-	Electromagnetic Compatibility
EN	-	European Standard
EUT	-	Equipment under test
ETSI	-	European Telecommunications Standard Institute
FCC	-	Federal Communication Commission
FCC ID	-	Company Identifier at FCC
HW	-	Hardware
IC	-	Industry Canada
Inv. No.	-	Inventory number
N/A	-	Not applicable
PP	-	Positive peak
QP	-	Quasi peak
S/N	-	Serial number
SW	-	Software

Annex F Accreditation Certificate



Front side of certificate



Back side of certificate

Note:
The current certificate including annex is published on our website (see link below) or may be received from CETECOM ICT Services on request.

http://www.cetecom.com/fileadmin/de/CETECOM_D_Saarbruecken/accreditations_Jan_2010/DAKKS_Akkredi_Urk_EN17025-En_incl_Annex.pdf