

TEST REPORT

Test report no.: 1-3325/11-02-04-A



Testing laboratory

CETECOM ICT Services GmbH
 Untertuerkheimer Strasse 6 – 10
 66117 Saarbruecken / Germany
 Phone: + 49 681 5 98 - 0
 Fax: + 49 681 5 98 - 9075
 Internet: <http://www.cetecom.com>
 e-mail: ict@cetecom.com

Accredited Testing Laboratory:

The testing laboratory (area of testing) is accredited according to DIN EN ISO/IEC 17025 (2005) by the Deutsche Akkreditierungsstelle GmbH (DAkkS). The accreditation is valid for the scope of testing procedures as stated in the accreditation certificate with the registration number: D-PL-12076-01-01
 Area of Testing: Radio/Satellite Communications

Applicant

FLIR Systems AB
 Rinkebyvägen 19
 SE-182 11 Danderyd / SWEDEN
 Phone: +46 (0) 8 753 27 50
 Contact: Göran Skedung
 e-mail: goran.skedung@flir.se
 Phone: +46 87 53 27 59

Manufacturer

FLIR Systems AB
 Rinkebyvägen 19
 SE-182 11 Danderyd / SWEDEN

Test standard/s

47 CFR Part 15 Title 47 of the Code of Federal Regulations; Chapter I
 Part 15 - Radio frequency devices

RSS - 210 Issue 8 Spectrum Management and Telecommunications - Radio Standards Specification
 Low-power Licence-exempt Radiocommunication Devices (All Frequency Bands):
 Category I Equipment

For further applied test standards please refer to section 3 of this test report.

Test Item

Kind of test item: Infrared Camera
Model name: FLIR-T55901
FCC ID: ZLV-FLIRT55901
IC: 5306A-FLIRT55901
Frequency [MHz]: ISM-band: 2400 MHz to 2483.5 MHz
 (lowest channel 00 – 2402 MHz,
 highest channel 78 – 2480 MHz)
Technology tested: Bluetooth®, +EDR
Antenna: Integrated antenna
Power Supply: 3.7 V DC by Li-polymer battery
Temperature Range: -20°C to +55 °C



This test report is electronically signed and valid without handwriting signature. For verification of the electronic signatures, the public keys can be requested at the testing laboratory.

Test report authorised:

[Signature box for Stefan Bös]

Stefan Bös
 Senior Testing Manager

Test performed:

[Signature box for Andreas Luckenbill]

Andreas Luckenbill

1 Table of contents	
1	Table of contents2
2	General information3
2.1	Notes and disclaimer3
2.2	Application details.....3
3	Test standard/s3
4	Test environment.....4
5	Test item4
6	Test laboratories sub-contracted4
7	Summary of measurement results5
8	RF measurements6
8.1	Description of test setup6
8.1.1	Radiated measurements.....6
8.1.2	Conducted measurements.....7
8.2	Additional comments7
8.3	RSP100 test report cover sheet / performance test data8
9	Measurement results.....9
9.1	Antenna gain.....9
9.2	Power spectral density19
9.3	Carrier frequency separation20
9.4	Number of hopping channels.....22
9.5	Time of occupancy (dwell time)24
9.6	Spectrum bandwidth of a FHSS system – 20 dB bandwidth25
9.7	Maximum output power31
9.8	Band edge compliance conducted38
9.9	Band edge compliance radiated45
9.10	TX spurious emissions conducted52
9.11	TX spurious emissions radiated70
9.12	RX spurious emissions radiated87
9.13	TX spurious emissions radiated < 30 MHz.....93
9.14	TX spurious emissions conducted < 30 MHz.....94
10	Test equipment and ancillaries used for tests97
11	Observations98
Annex A	Photographs of the test setup99
Annex B	External photographs of the EUT102
Annex C	Internal photographs of the EUT108
Annex D	Document history113
Annex E	Further information.....113
Annex F	Accreditation Certificate114

2 General information

2.1 Notes and disclaimer

The test results of this test report relate exclusively to the test item specified in this test report. CETECOM ICT Services GmbH does not assume responsibility for any conclusions and generalizations drawn from the test results with regard to other specimens or samples of the type of the equipment represented by the test item.

The test report may only be reproduced or published in full. Reproduction or publication of extracts from the report requires the prior written approval of CETECOM ICT Services GmbH.

The testing service provided by CETECOM ICT Services GmbH has been rendered under the current "General Terms and Conditions for CETECOM ICT Services GmbH".

CETECOM ICT Services GmbH will not be liable for any loss or damage resulting from false, inaccurate, inappropriate or incomplete product information provided by the customer.

Under no circumstances does the CETECOM ICT Services GmbH test report include any endorsement or warranty regarding the functionality, quality or performance of any other product or service provided.

Under no circumstances does the CETECOM ICT Services GmbH test report include or imply any product or service warranties from CETECOM ICT Services GmbH, including, without limitation, any implied warranties of merchantability, fitness for purpose, or non-infringement, all of which are expressly disclaimed by CETECOM ICT Services GmbH.

All rights and remedies regarding vendor's products and services for which CETECOM ICT Services GmbH has prepared this test report shall be provided by the party offering such products or services and not by CETECOM ICT Services GmbH.

In no case this test report can be considered as a Letter of Approval.

This test report is electronically signed and valid without handwritten signature. For verification of the electronic signatures, the public keys can be requested at the testing laboratory.

2.2 Application details

Date of receipt of order:	2012-01-24
Date of receipt of test item:	2012-01-24
Start of test:	2012-01-24
End of test:	2012-02-03
Person(s) present during the test:	-/-

3 Test standard/s

Test standard	Date	Test standard description
47 CFR Part 15	2010-10	Title 47 of the Code of Federal Regulations; Chapter I Part 15 - Radio frequency devices
RSS - 210 Issue 8	2010-12	Spectrum Management and Telecommunications - Radio Standards Specification Low-power Licence-exempt Radiocommunication Devices (All Frequency Bands): Category I Equipment

4 Test environment

Temperature:	T_{nom}	+22 °C during room temperature tests
	T_{max}	+55 °C during high temperature tests
	T_{min}	-20 °C during low temperature tests
Relative humidity content:		33 %
Barometric pressure:		not relevant for this kind of testing
Power supply:	V_{nom}	3.7 V DC by Li-polymer battery
	V_{max}	-/-
	V_{min}	-/-

5 Test item

Kind of test item	:	Infrared Camera
Type identification	:	FLIR-T55901
S/N serial number	:	Rad. 55800022 Cond. 55800032
HW hardware status	:	T197516 rev 01
SW software status	:	version 1.35.23
Frequency band [MHz]	:	ISM-band: 2400 MHz to 2483.5 MHz (lowest channel 00 – 2402, highest channel 78 – 2480)
Type of modulation	:	FHSS technology with GFSK, Pi/4 DQPSK and 8 DPSK.
Number of channels	:	79
Antenna	:	Integrated antenna
Power supply	:	3.7 V DC by Li-polymer battery
Temperature range	:	-20°C to +55 °C

6 Test laboratories sub-contracted

None

7 Summary of measurement results



No deviations from the technical specifications were ascertained



There were deviations from the technical specifications ascertained

TC Identifier	Description	Verdict	Date	Remark
RF-Testing	CFR Part 15 RSS 210, Issue 8, Annex 8	Passed	2012-02-23	-/-

Test specification clause	Test case	Temperature conditions	Power source voltages	Mode	Pass	Fail	NA	NP	Remark
§15.247(b)(4) RSS 210 / A8.4(2)	Antenna gain	Nominal	Nominal	GFSK	<input type="checkbox"/>	<input type="checkbox"/>	<input type="checkbox"/>	<input checked="" type="checkbox"/>	Antenna pattern supplied by applicant
§15.247(e) RSS 210 / A8.2(b)	Power spectral density	Nominal	Nominal	GFSK Pi/4 DQPSK 8 DPSK	<input type="checkbox"/>	<input type="checkbox"/>	<input checked="" type="checkbox"/>	<input type="checkbox"/>	Not applicable for FHSS!
§15.247(a)(1) RSS 210 / A8.1(b)	Carrier frequency separation	Nominal	Nominal	GFSK	<input checked="" type="checkbox"/>	<input type="checkbox"/>	<input type="checkbox"/>	<input type="checkbox"/>	complies
§15.247(a)(1) RSS 210 / A8.1(d)	Number of hopping channels	Nominal	Nominal	GFSK	<input checked="" type="checkbox"/>	<input type="checkbox"/>	<input type="checkbox"/>	<input type="checkbox"/>	complies
§15.247(a)(1) (iii) RSS 210 / A8.3(1)	Time of occupancy (dwell time)	Nominal	Nominal	GFSK Pi/4 DQPSK 8 DPSK	<input checked="" type="checkbox"/>	<input type="checkbox"/>	<input type="checkbox"/>	<input type="checkbox"/>	complies
§15.247(a)(1) RSS 210 / A8.2(a)	Spectrum bandwidth of a FHSS system 20dB bandwidth	Nominal	Nominal	GFSK Pi/4 DQPSK 8 DPSK	<input checked="" type="checkbox"/> <input checked="" type="checkbox"/> <input checked="" type="checkbox"/>	<input type="checkbox"/> <input type="checkbox"/> <input type="checkbox"/>	<input type="checkbox"/> <input type="checkbox"/> <input type="checkbox"/>	<input type="checkbox"/> <input type="checkbox"/> <input type="checkbox"/>	complies
§15.247(b)(1) RSS-210 / A8.4(2)	Maximum output power	Nominal	Nominal	GFSK Pi/4 DQPSK 8 DPSK	<input checked="" type="checkbox"/> <input checked="" type="checkbox"/> <input checked="" type="checkbox"/>	<input type="checkbox"/> <input type="checkbox"/> <input type="checkbox"/>	<input type="checkbox"/> <input type="checkbox"/> <input type="checkbox"/>	<input type="checkbox"/> <input type="checkbox"/> <input type="checkbox"/>	complies
§15.247(d) RSS-210 / A8.5	Band edge compliance conducted	Nominal	Nominal	GFSK Pi/4 DQPSK 8 DPSK	<input checked="" type="checkbox"/> <input checked="" type="checkbox"/> <input checked="" type="checkbox"/>	<input type="checkbox"/> <input type="checkbox"/> <input type="checkbox"/>	<input type="checkbox"/> <input type="checkbox"/> <input type="checkbox"/>	<input type="checkbox"/> <input type="checkbox"/> <input type="checkbox"/>	complies
§15.205 RSS-210 / A8.5	Band edge compliance radiated	Nominal	Nominal	GFSK Pi/4 DQPSK 8 DPSK	<input checked="" type="checkbox"/> <input checked="" type="checkbox"/> <input checked="" type="checkbox"/>	<input type="checkbox"/> <input type="checkbox"/> <input type="checkbox"/>	<input type="checkbox"/> <input type="checkbox"/> <input type="checkbox"/>	<input type="checkbox"/> <input type="checkbox"/> <input type="checkbox"/>	complies
§15.247(d) RSS-210 / A8.5	TX spurious emissions conducted	Nominal	Nominal	GFSK Pi/4 DQPSK 8 DPSK	<input checked="" type="checkbox"/> <input checked="" type="checkbox"/> <input checked="" type="checkbox"/>	<input type="checkbox"/> <input type="checkbox"/> <input type="checkbox"/>	<input type="checkbox"/> <input type="checkbox"/> <input type="checkbox"/>	<input type="checkbox"/> <input type="checkbox"/> <input type="checkbox"/>	complies
§15.247(d) RSS-210 / A8.5	TX spurious emissions radiated	Nominal	Nominal	GFSK	<input checked="" type="checkbox"/>	<input type="checkbox"/>	<input type="checkbox"/>	<input type="checkbox"/>	complies
§15.109 RSS-Gen.	RX spurious emissions radiated	Nominal	Nominal	-/-	<input checked="" type="checkbox"/>	<input type="checkbox"/>	<input type="checkbox"/>	<input type="checkbox"/>	complies
§15.209(a) RSS-Gen	TX spurious emissions radiated < 30 MHz	Nominal	Nominal	GFSK	<input type="checkbox"/>	<input type="checkbox"/>	<input type="checkbox"/>	<input checked="" type="checkbox"/>	-/-
§15.107(a)	Conducted emissions < 30 MHz	Nominal	Nominal	GFSK	<input checked="" type="checkbox"/>	<input type="checkbox"/>	<input type="checkbox"/>	<input type="checkbox"/>	complies

Note: NA = Not Applicable; NP = Not Performed

8 RF measurements

8.1 Description of test setup

8.1.1 Radiated measurements

The radiated measurements are performed in vertical and horizontal plane in the frequency range from 9 kHz to 25 GHz in semi-anechoic chambers. The EUT is positioned on a non-conductive support with a height of 0.80 m above a conductive ground plane that covers the whole chamber. The receiving antennas are confirmed with specifications ANSI C63.2-1996 clause 15 and ANSI C63.4-2009 clause 4.1.5. These antennas can be moved over the height range between 1.0 m and 4.0 m in order to search for maximum field strength emitted from EUT. The measurement distances between EUT and receiving antennas are indicated in the test setups for the various frequency ranges. For each measurement, the EUT is rotated in all three axes until the maximum field strength is received. The wanted and unwanted emissions are received by spectrum analysers where the detector modes and resolution bandwidths over various frequency ranges are set according to requirement ANSI C63-4-2009 clause 4.2.

Antennas are confirmed with ANSI C63.2-1996 item 15.

Semi anechoic chamber

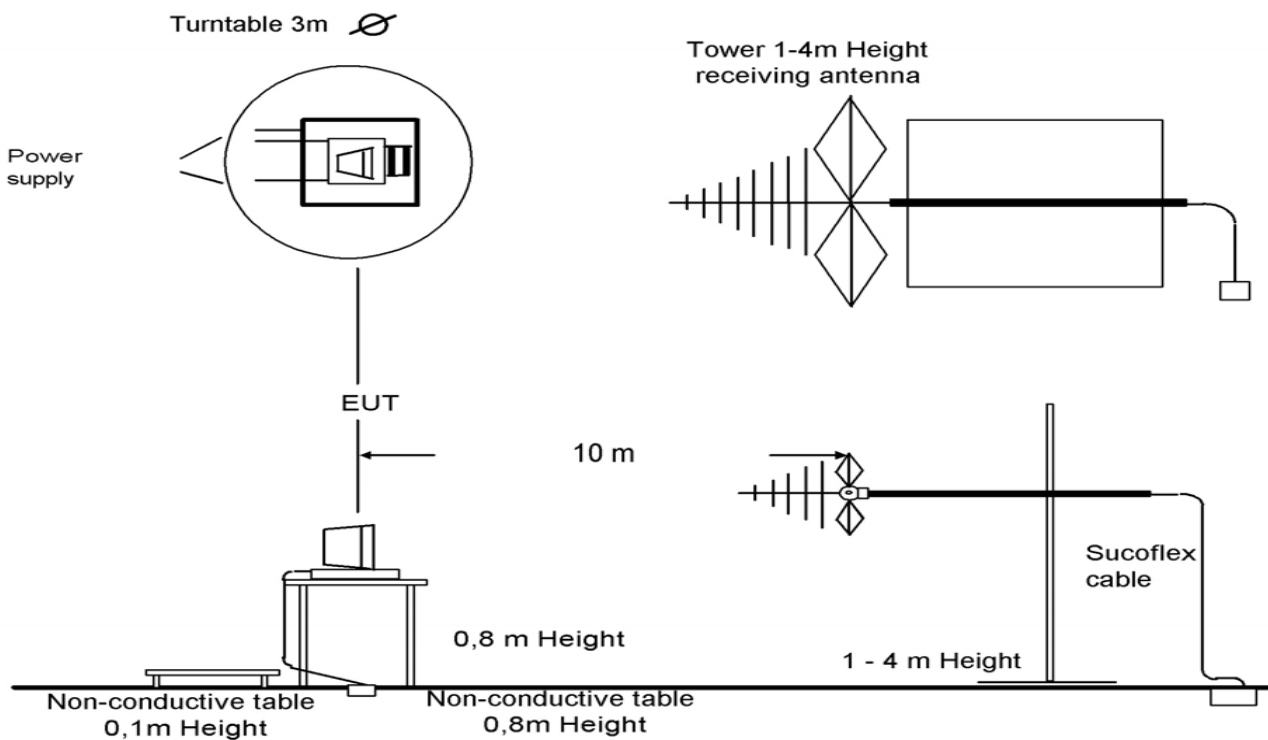

Picture 1: Diagram radiated measurements

9 kHz - 30 MHz:	active loop antenna
30 MHz – 1 GHz:	tri-log antenna
> 1 GHz:	horn antenna

All measurements are done in accordance with the Filing and Measurement Guidelines for Frequency Hopping Spread Spectrum Systems DA 00-705 and Appendix A “BLUETOOTH® APPROVALS”

The EUT is powered by an external power supply with nominal voltage. The signalling is performed from outside the chamber with a signalling unit (CMU200 or other) by air link using signalling antenna.

8.1.2 Conducted measurements

The EUT's RF signal is coupled out by the antenna connector which is supplied by the manufacturer. The signal is first 10dB attenuated before it is power divided (~6dB loss per branch). One of the signal paths is connected to the communication base Station (CMU200 or other), the other one is connected to the spectrum analyzer. The specific losses for both signal paths are first checked within a calibration. The measurement readings on the signalling unit/spectrum analyzer are corrected by the specific test set-up loss. The attenuator, power divider, signalling unit and the spectrum analyzer are impedance matched on 50 Ohm.

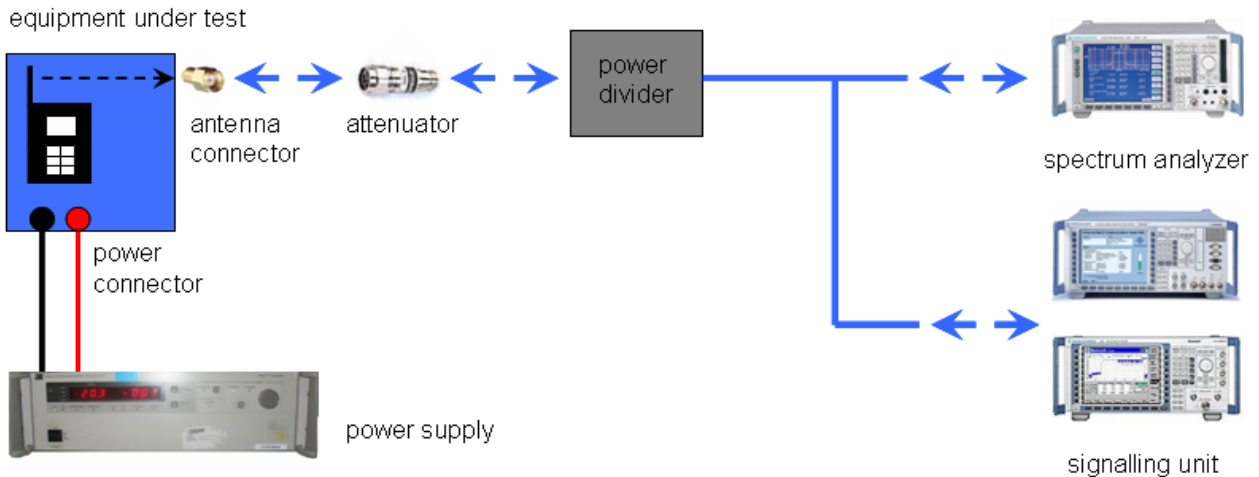

Picture 2: Diagram conducted measurements

8.2 Additional comments

The Bluetooth® word mark and logos are owned by the Bluetooth SIG Inc. and any use of such marks by Cetecom ICT Services GmbH is under license.

Reference documents: None

Special test descriptions: None

Configuration descriptions: TX tests: were performed with x-DH5 packets and static PRBS pattern payload.
RX/Standby tests: BT test mode enabled, scan enabled, TX Idle

Test mode:

- Bluetooth Test mode loop back enabled (EUT is controlled over CBT/CMU)
- Special software is used. EUT is transmitting pseudo random data by itself

8.3 RSP100 test report cover sheet / performance test data

Test report number	:	1-3325/11-02-04-A
Equipment model number	:	FLIR-T55901
Certification number	:	5306A-FLIRT55901
Manufacturer (complete address)	:	FLIR Systems AB Rinkebyvägen 19 SE-182 11 Danderyd / SWEDEN
Tested to radio standards specification no.	:	RSS 210, Issue 8, Annex 8
Open area test site IC No.	:	IC 3462C-1
Frequency range	:	ISM band 2400 MHz to 2483.5 MHz (lowest channel 2402 MHz, highest channel 2480 MHz)
RF-power [W] (max.)	:	Cond.: 0.90 mW (GFSK modulation) EIRP: 2.88 mW (GFSK modulation) Cond.: 0.57 mW (Pi/4-DQPSK modulation) EIRP: 1.91 mW (Pi/4-DQPSK modulation) Cond.: 0.57 mW (8DPSK modulation) EIRP: 1.97 mW (8DPSK modulation)
Occupied bandwidth (99%-BW) [kHz]	:	803 (GFSK modulation) 1125 (Pi/4-DQPSK modulation) 1188 (8DPSK modulation)
Type of modulation	:	FHSS technology with GFSK, Pi/4 DQPSK and 8 DPSK modulations.
Emission designator (TRC-43)	:	803 KFXD (GFSK modulation) 1M13GXD (Pi/4-DQPSK modulation) 1M19GXD (8DPSK modulation)
Antenna information	:	Integrated antenna
Transmitter spurious (worst case) [dB μ V/m @ 3m]:		45 @ 10 GHz (noise floor)
Receiver spurious (worst case) [dB μ V/m @ 3m]:		45 @ 10 GHz (noise floor)

ATTESTATION:

DECLARATION OF COMPLIANCE:

I attest that the testing was performed or supervised by me; that the test measurements were made in accordance with the above-mentioned Industry Canada standard(s); and that the equipment identified in this application has been subjected to all the applicable test conditions specified in the Industry Canada standards and all of the requirements of the standard have been met.

Laboratory manager:

2012-02-23

Date

Andreas Luckenbill

Name



Signature

9 Measurement results

9.1 Antenna gain

The following data of antenna measurements were supplied by the applicant:

Lens position 1

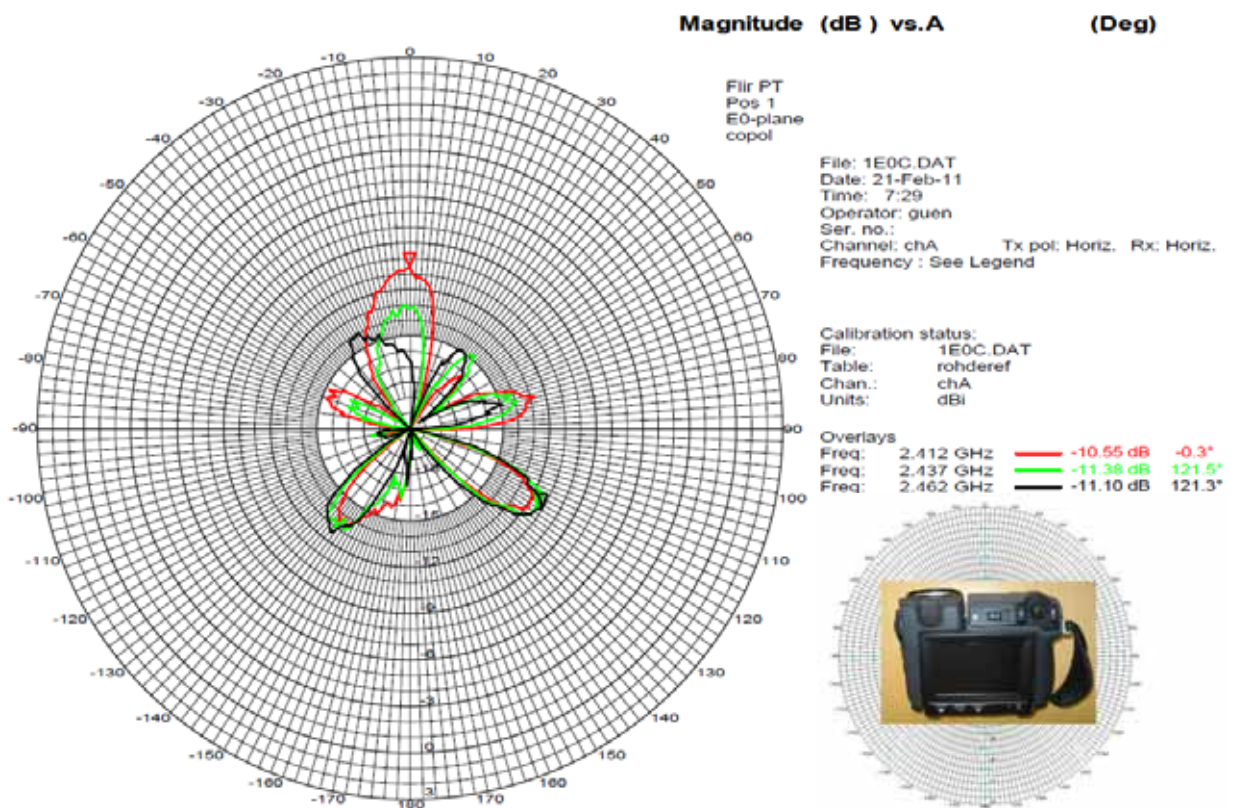

Fig 1: Lens position 1. E0-plane, horizontal polarization.

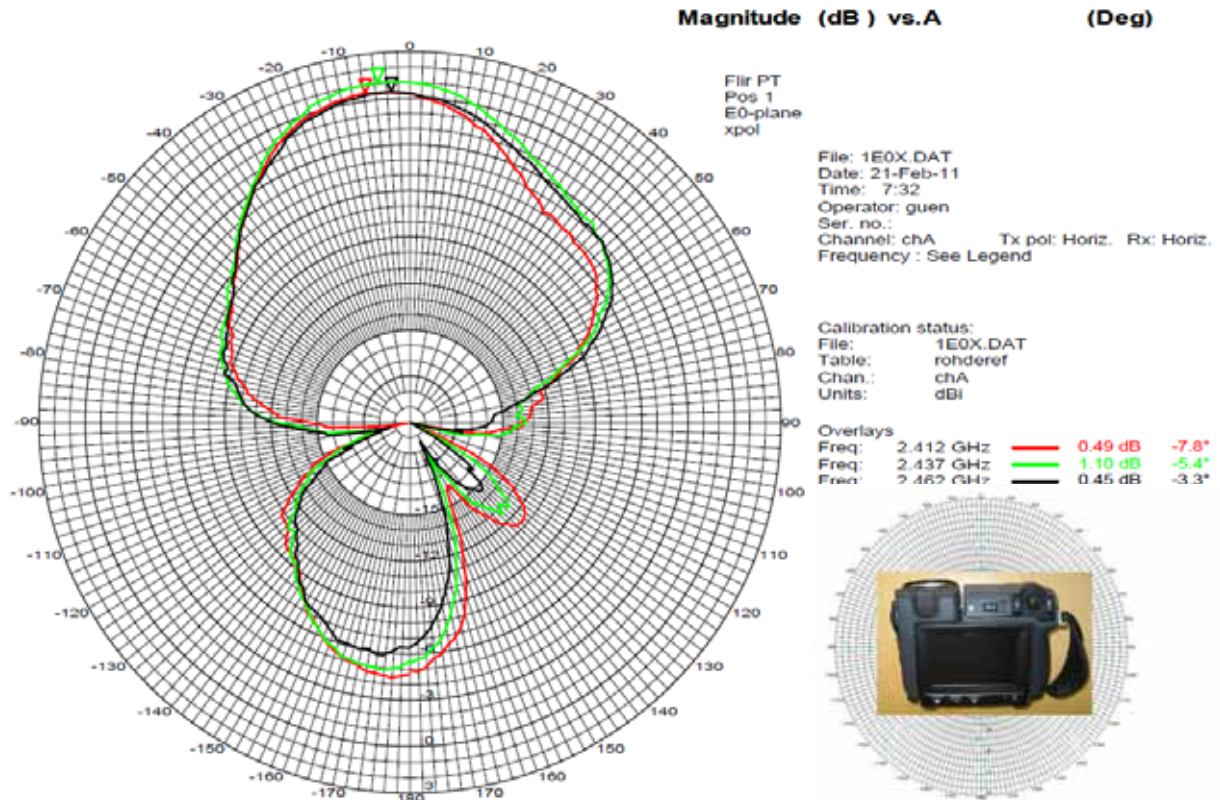

Fig 2: Lens position 1. E0-plane, vertical polarization.

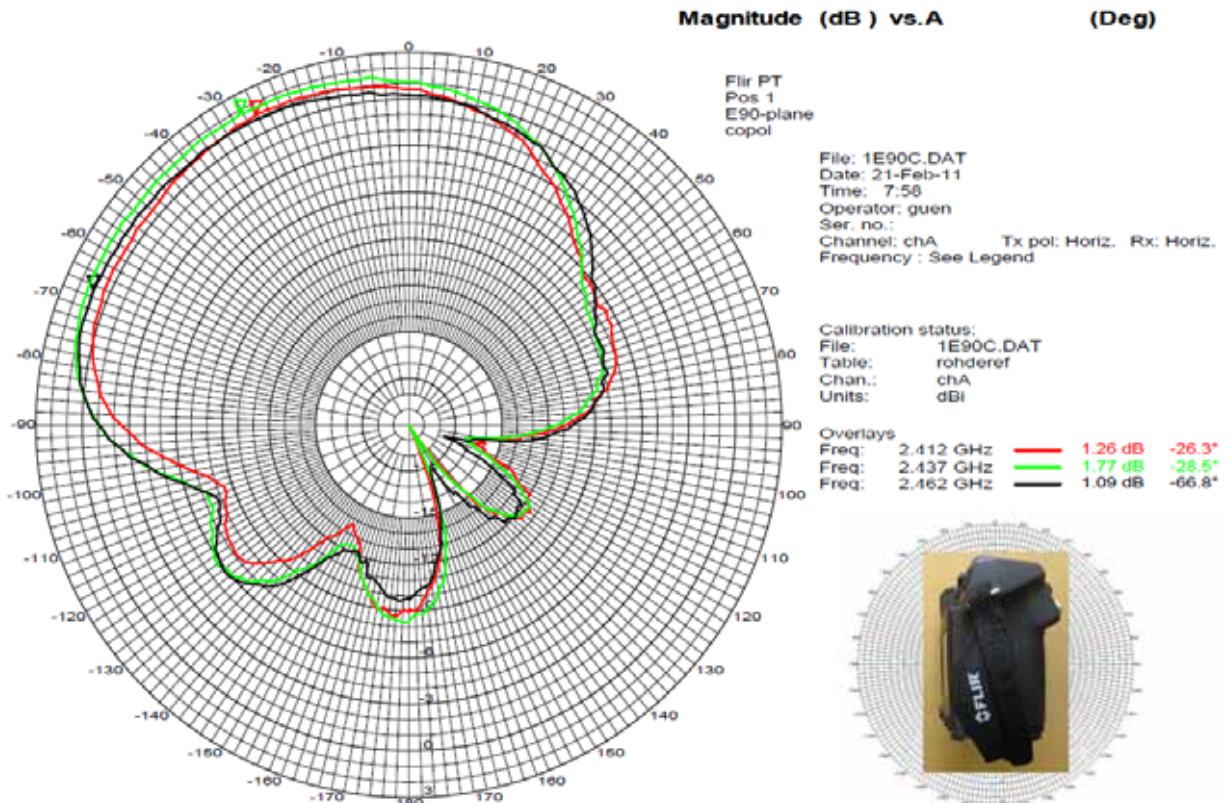

Fig 3: Lens position 1. E90-plane, horizontal polarization.

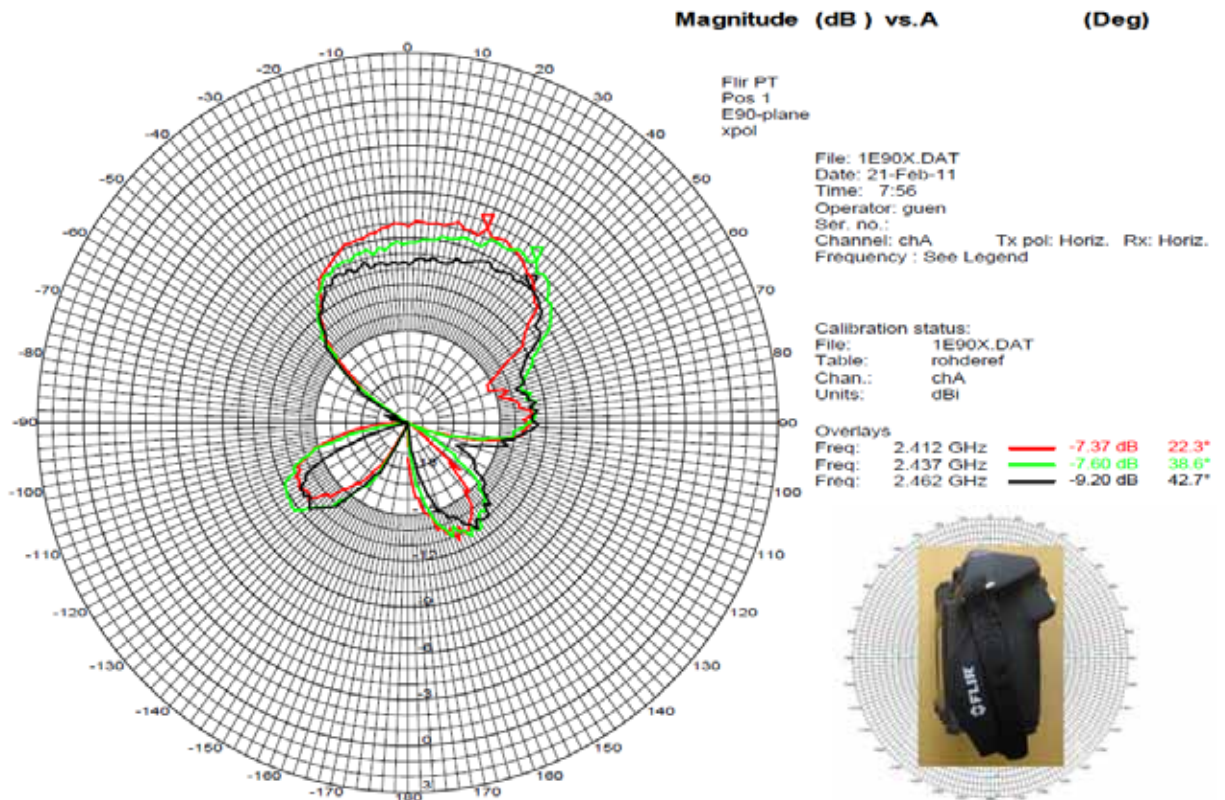

Fig 4: Lens position 1. E90-plane, vertical polarization.

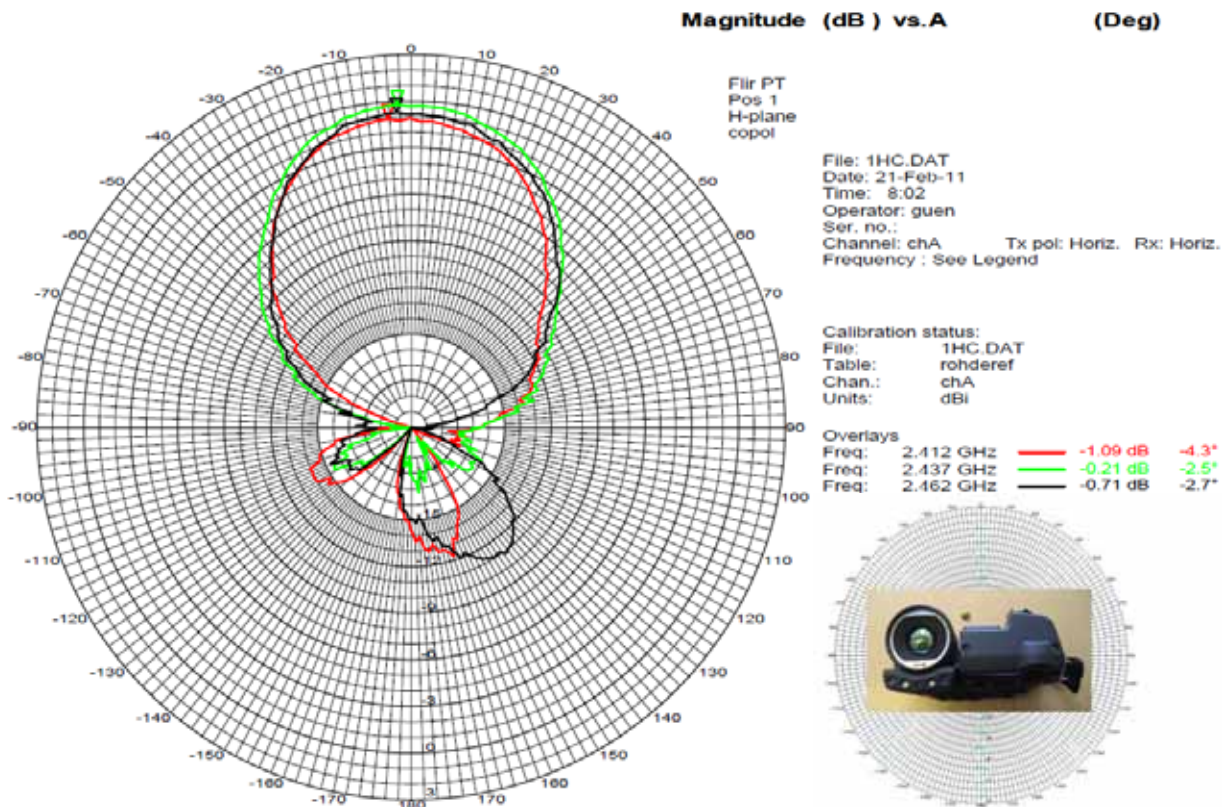

Fig 5: Lens position 1. H-plane, vertical polarization.

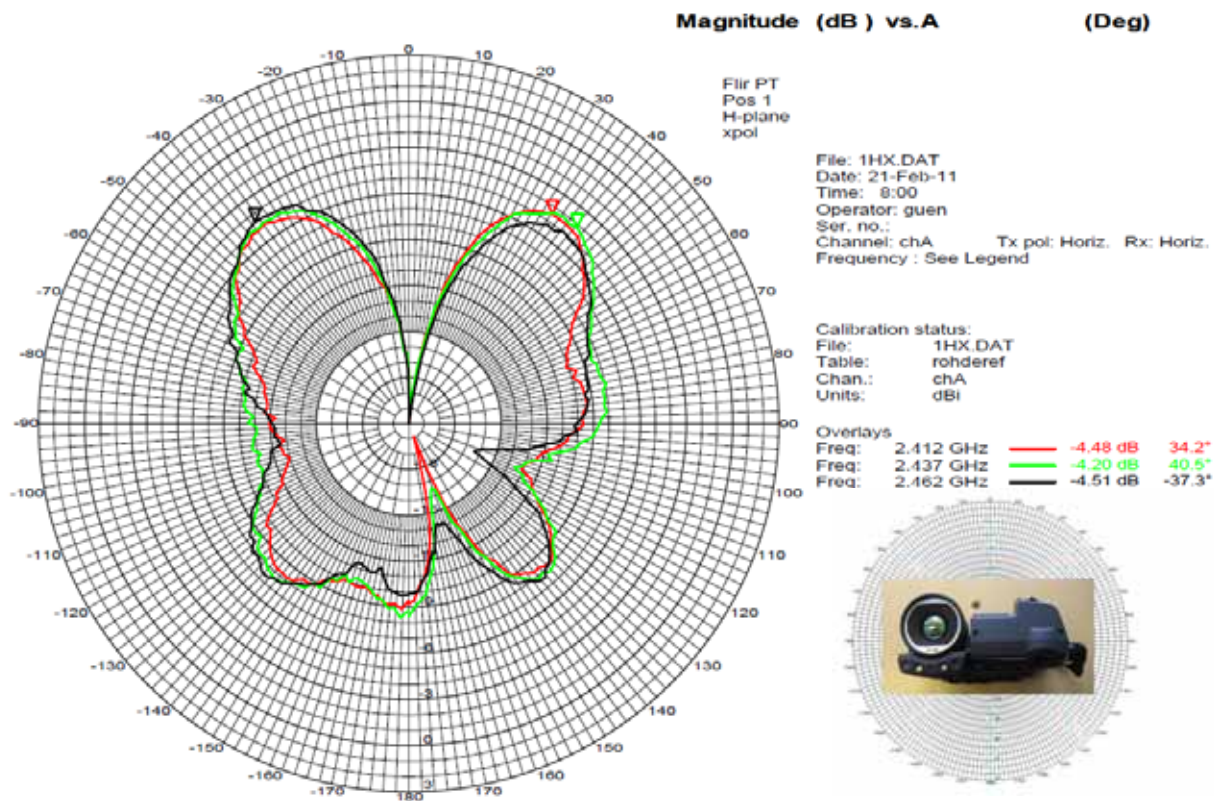

Fig 6: Lens position 1. H-plane, horizontal polarization.

Lens position 2

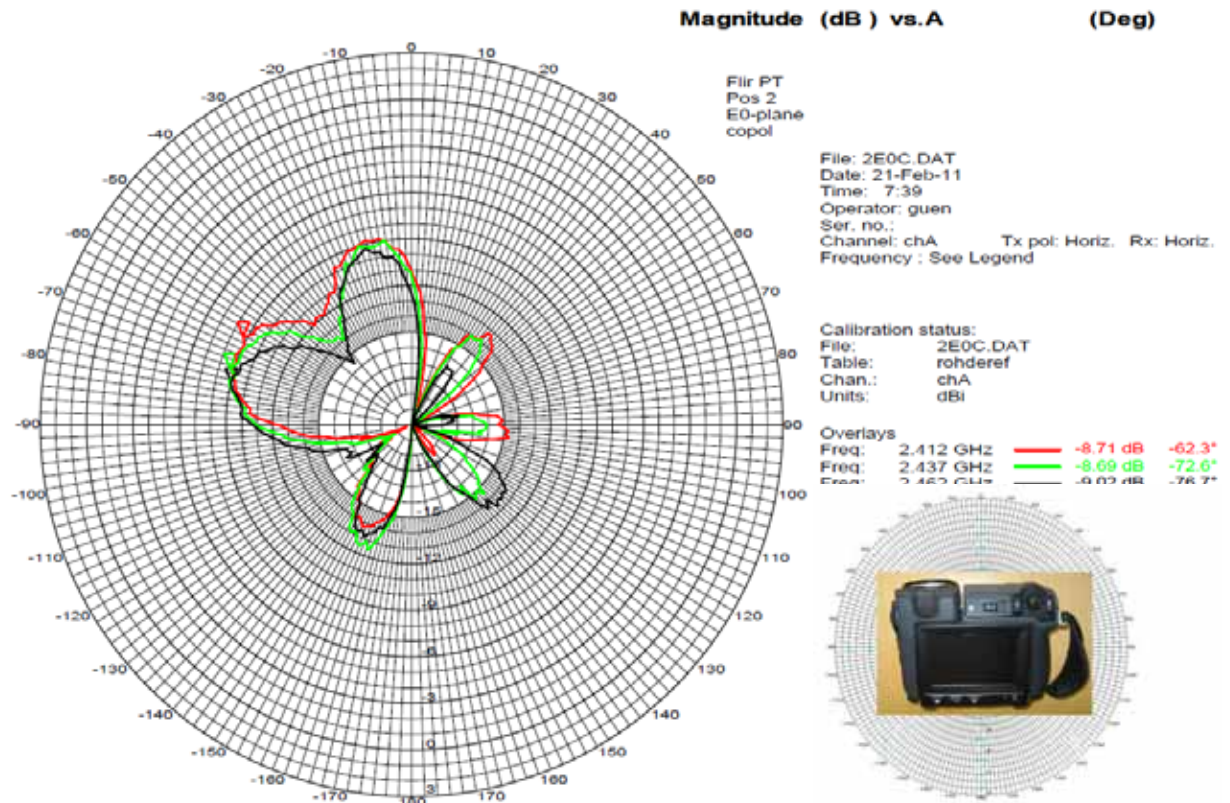

Fig 7: Lens position 2. E0-plane, horizontal polarization.

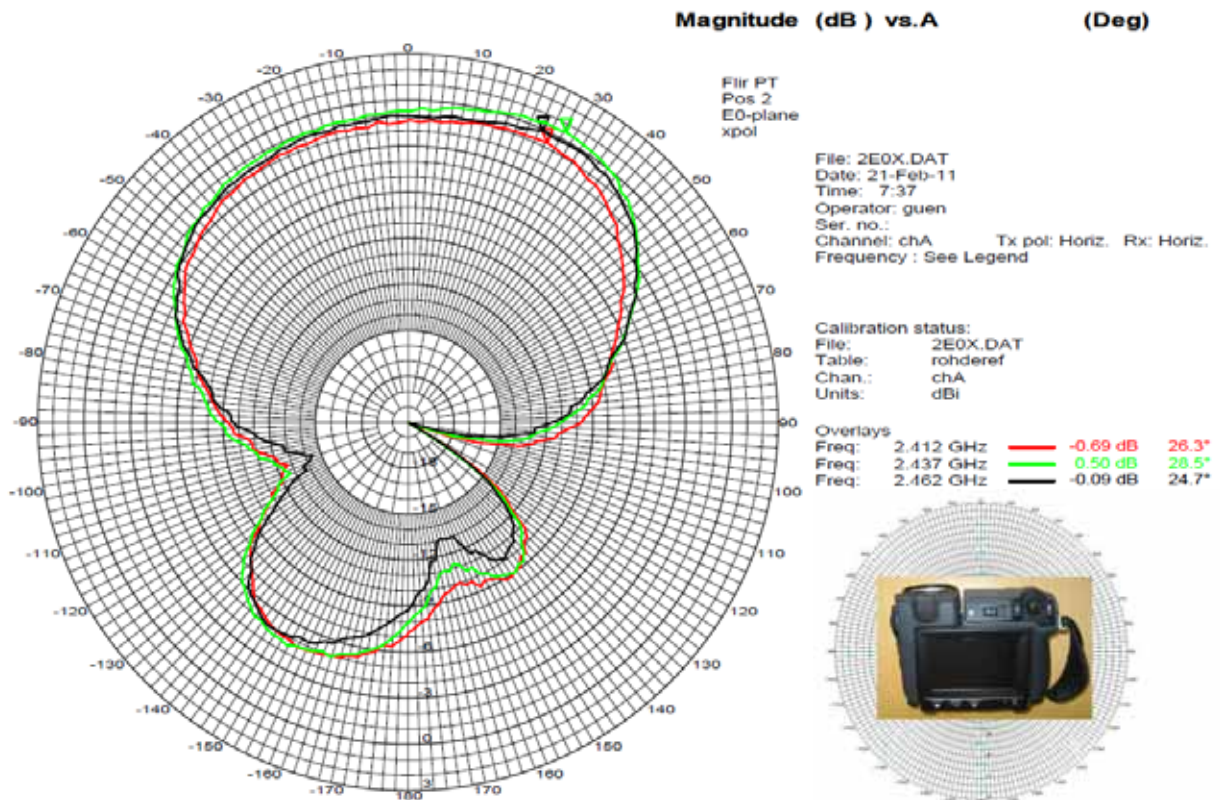

Fig 8: Lens position 2. E0-plane, vertical polarization.

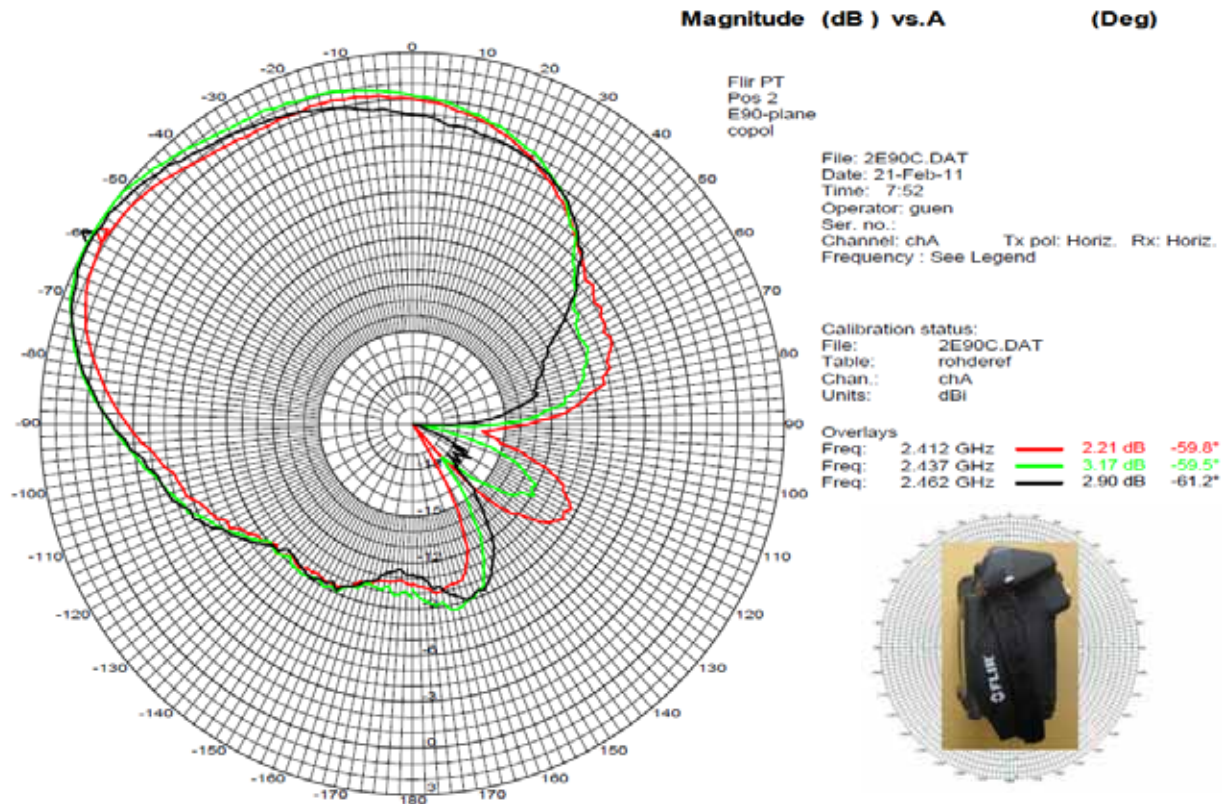

Fig 9: Lens position 2. E90-plane, horizontal polarization.

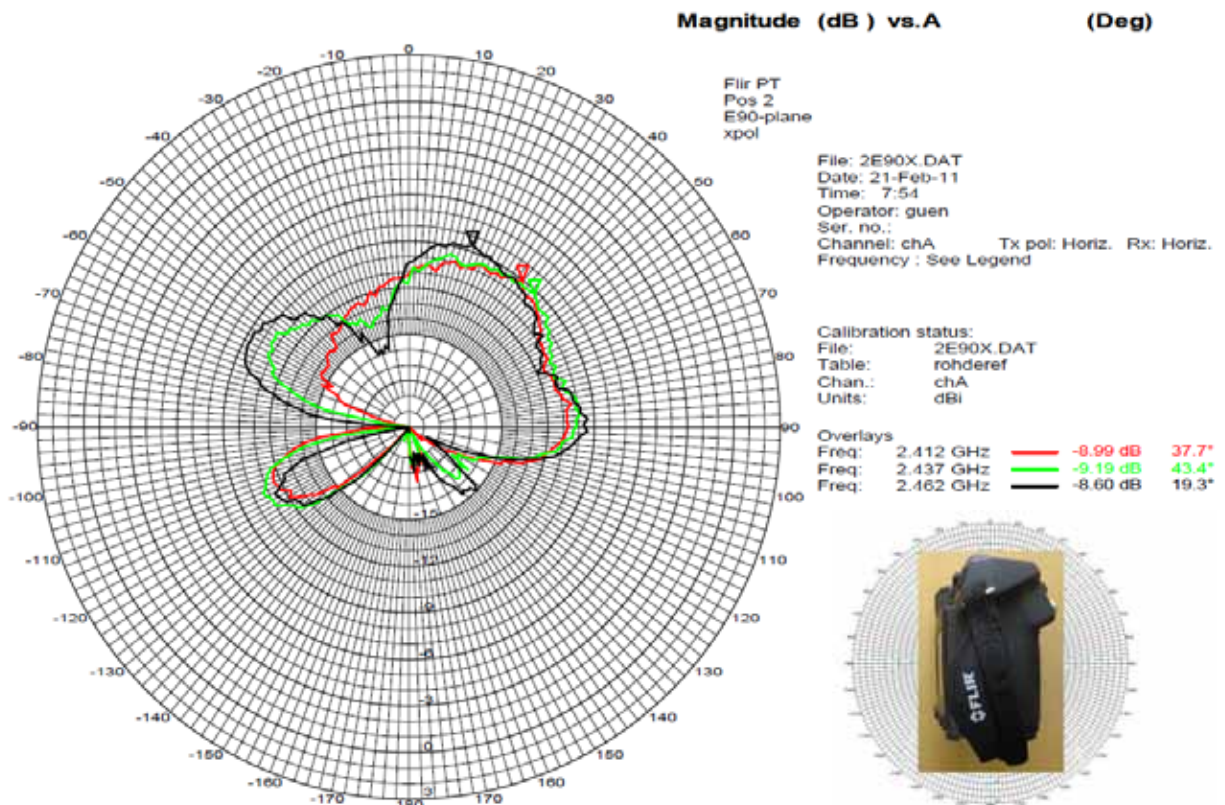

Fig 10: Lens position 2. E90-plane, vertical polarization.

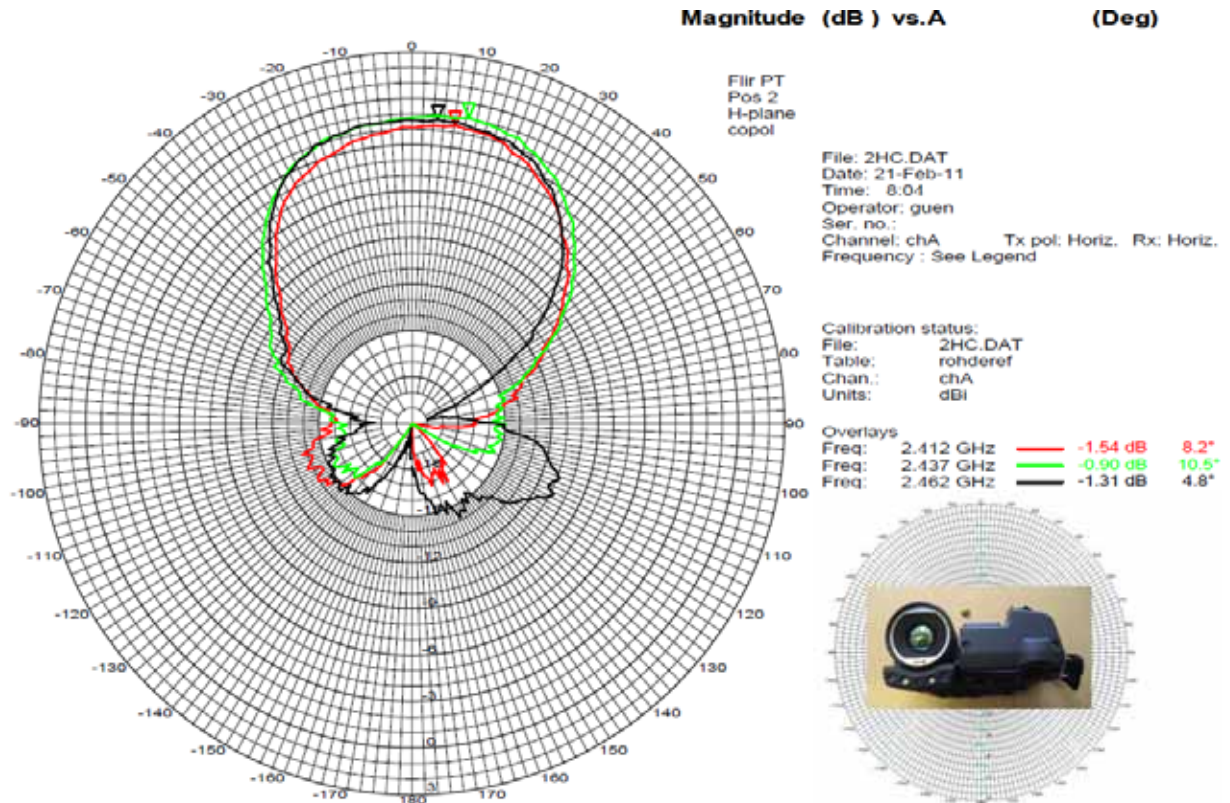

Fig 11: Lens position 2. H-plane, vertical polarization.

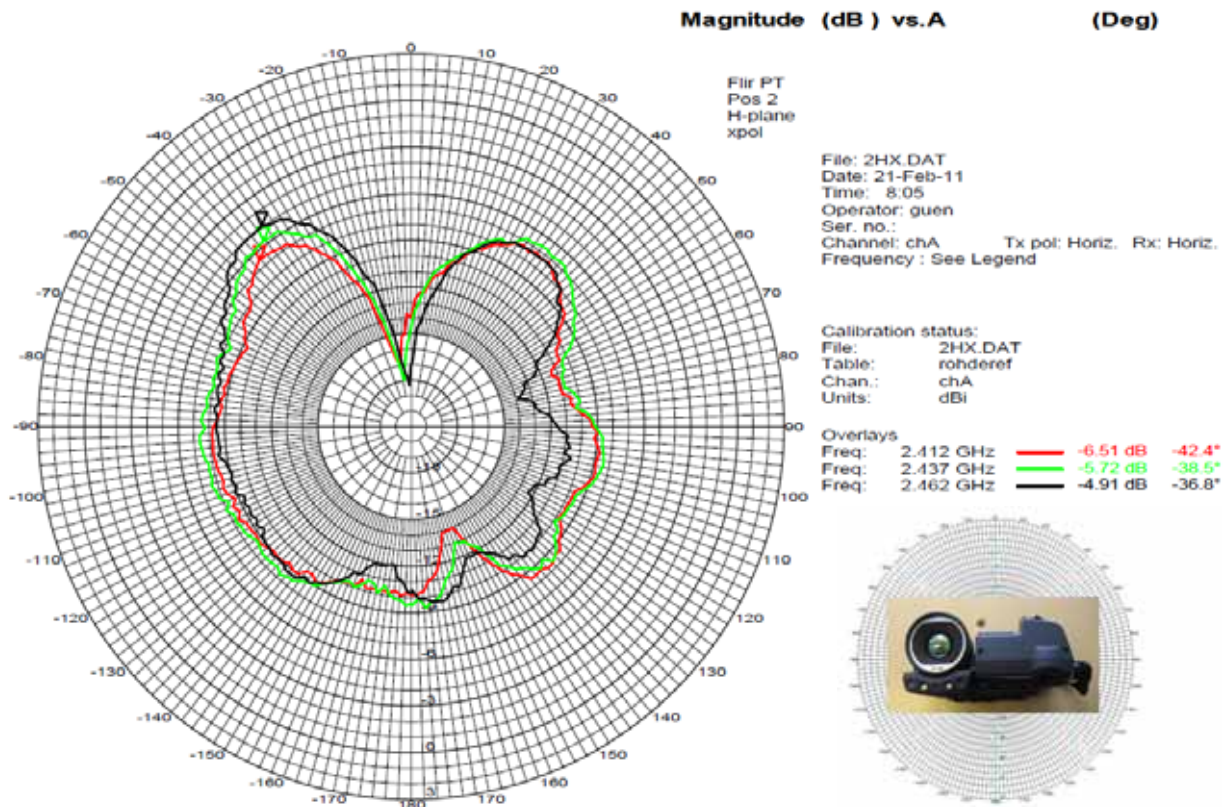

Fig 12: Lens position 2. H-plane, horizontal polarization.

Lens position 3

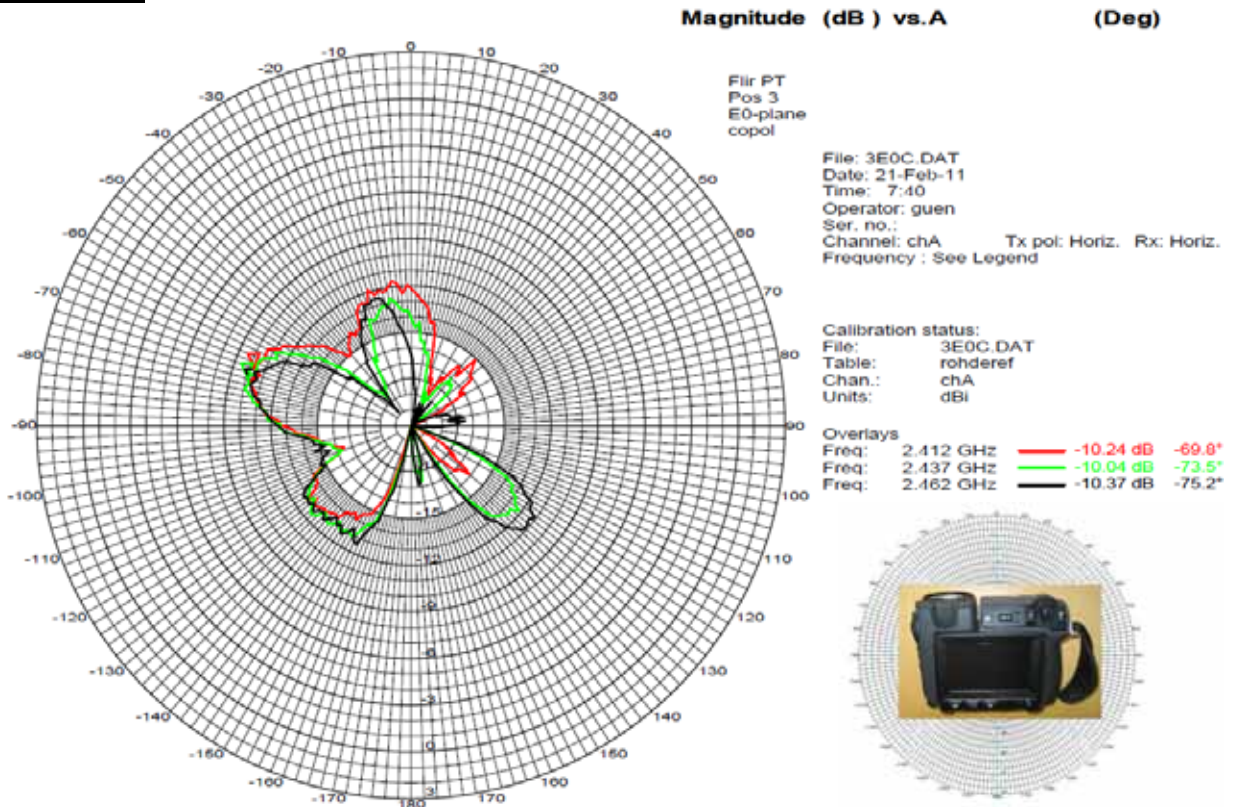

Fig 13: Lens position 3. E0-plane, horizontal polarization.

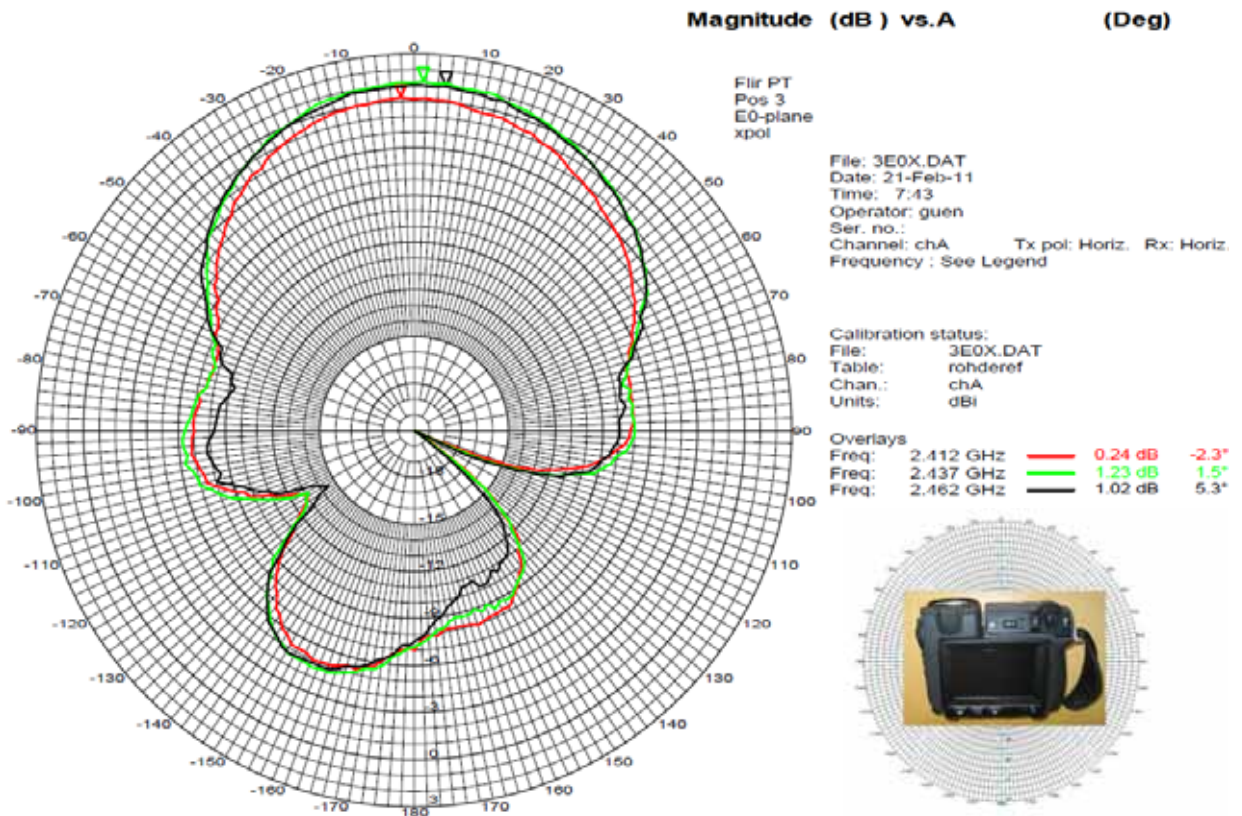

Fig 14: Lens position 3. E0-plane, vertical polarization.

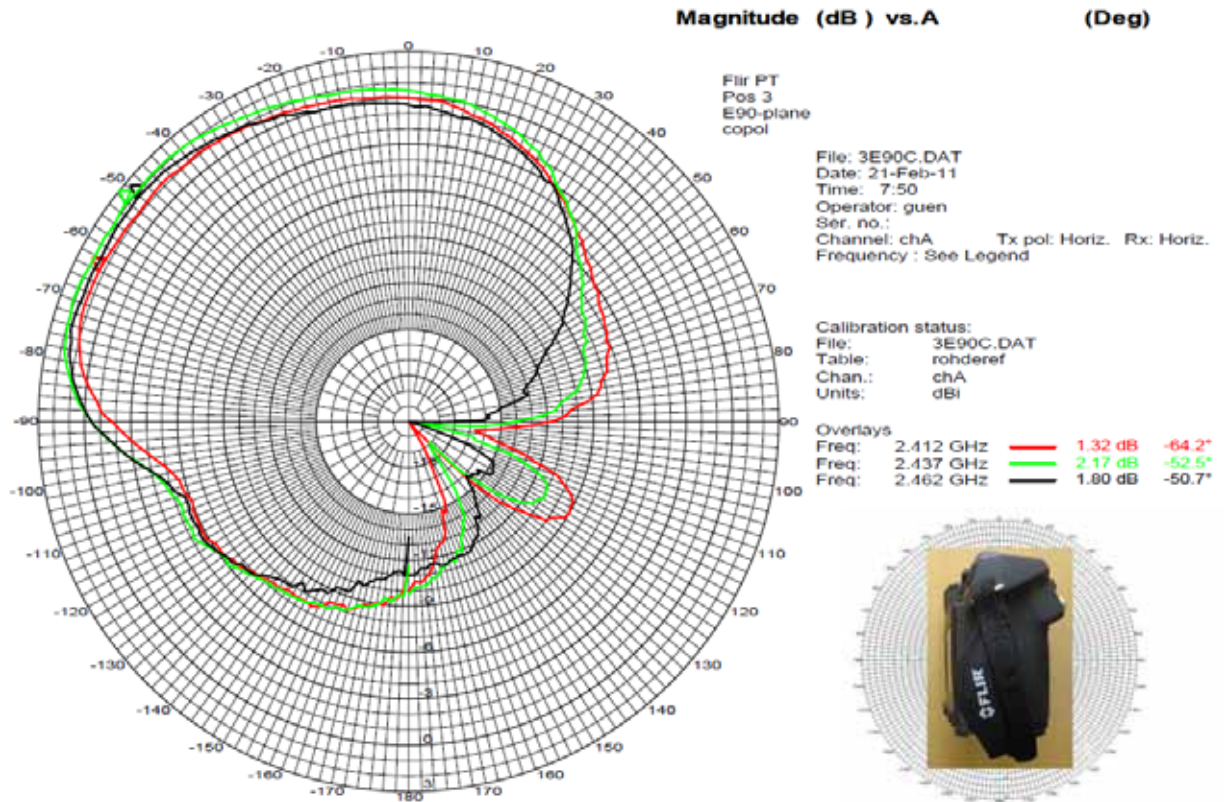

Fig 15: Lens position 3. E90-plane, horizontal polarization.

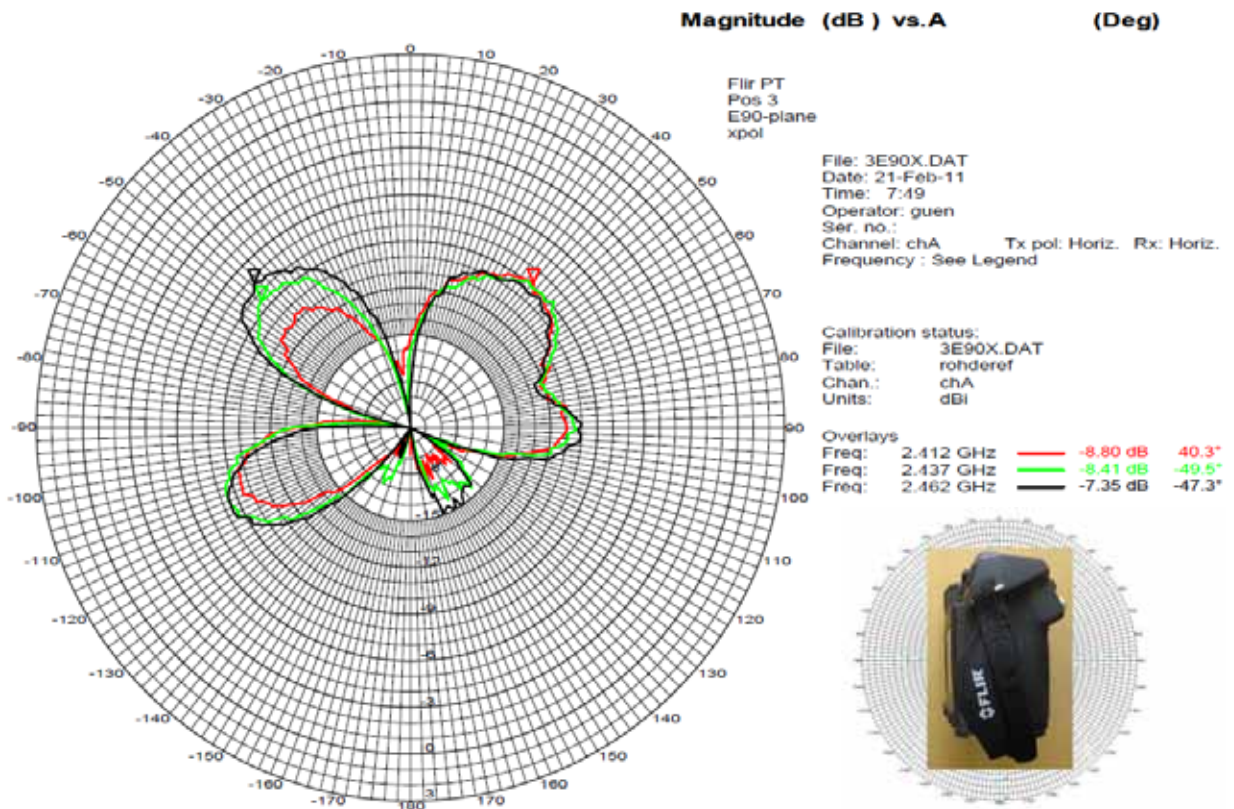

Fig 16: Lens position 3. E90-plane, vertical polarization.

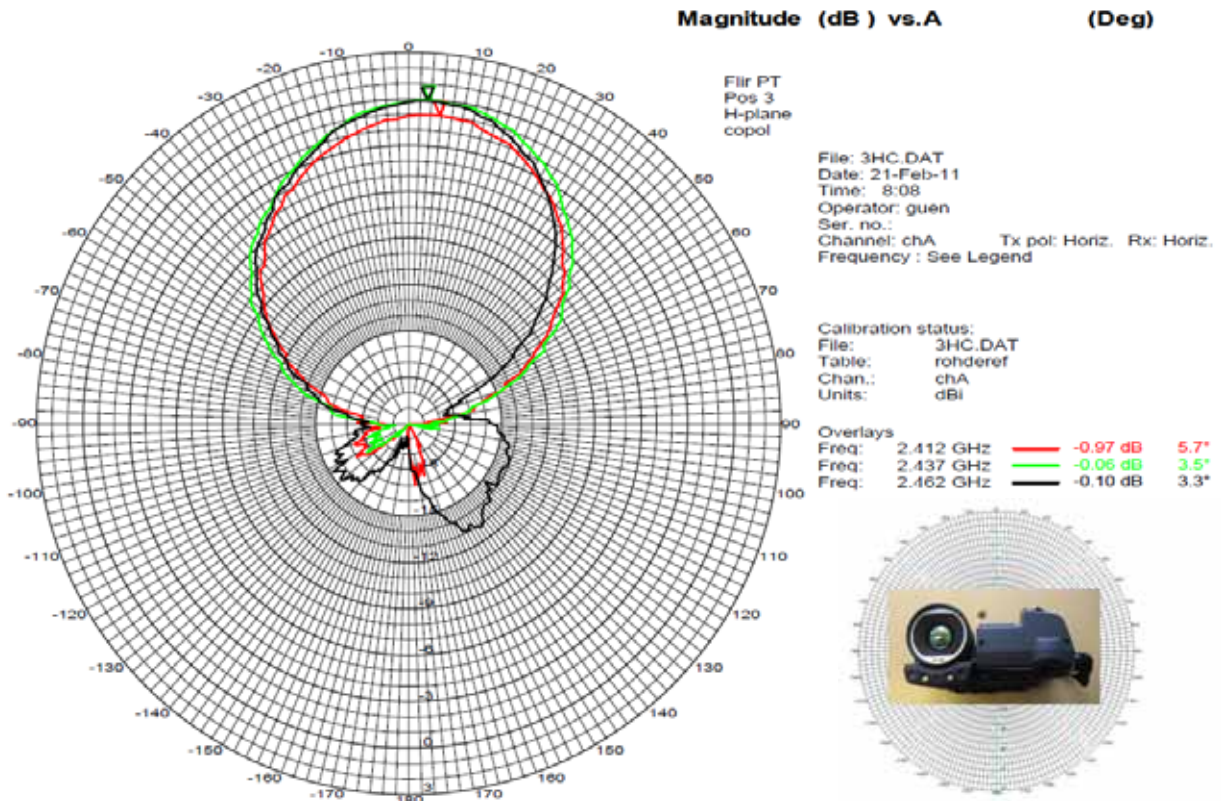

Fig 17: Lens position 3. H-plane, vertical polarization.

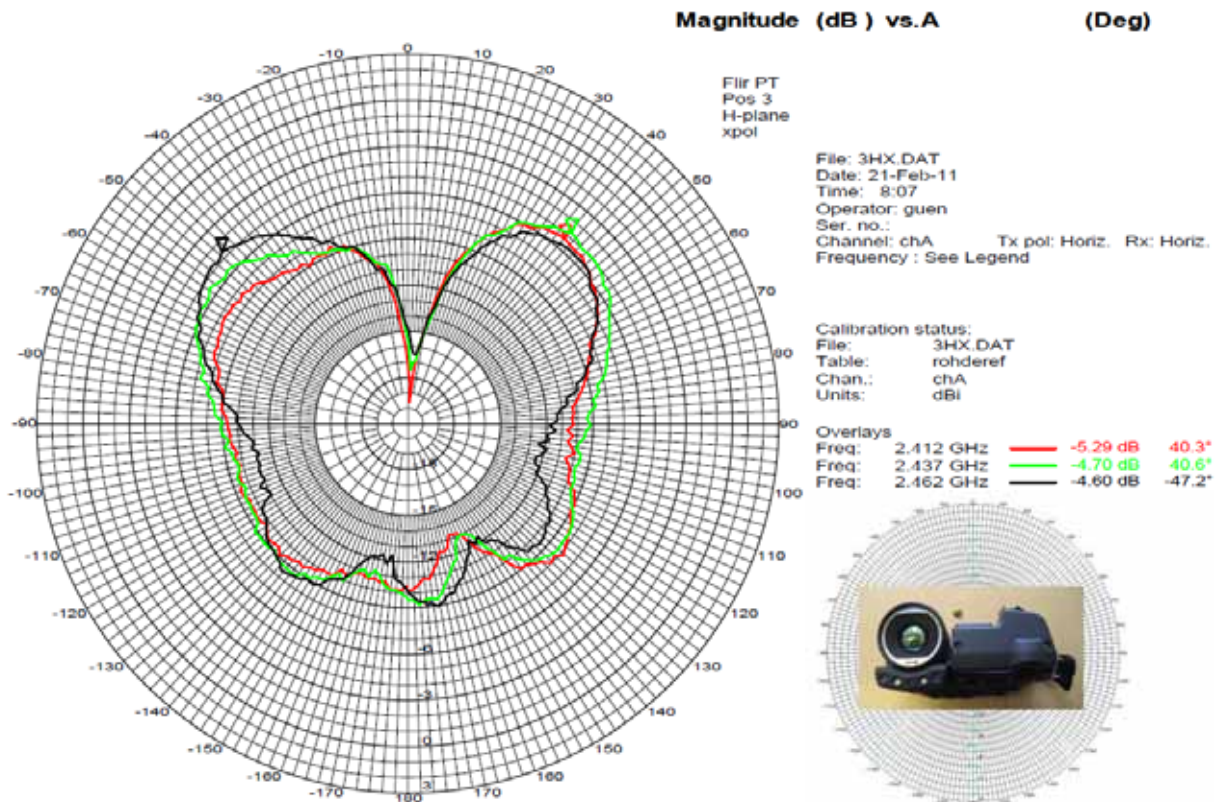

Fig 18: Lens position 3. H-plane, horizontal polarization.

9.2 Power spectral density

Description:

Measurement of the power spectral density of a digital modulated system. This requirement is only valid for digitally modulated systems without hopping functionality.

Measurement:

Measurement parameter	
Detector:	Peak
Sweep time:	500 s
Video bandwidth:	3 kHz
Resolution bandwidth:	3 kHz
Span:	150 kHz
Trace-Mode:	Max Hold

Limits:

FCC	IC
CFR Part 15.247 (e)	RSS 210, Issue 8, A 8.2(b)
Power Spectral Density	
For digitally modulated systems the transmitter power spectral density conducted from the transmitter to the antenna shall not be greater than 8 dBm in any 3 kHz band during any time interval of continuous transmission or over 1.0 second if the transmission exceeds 1.0-second duration.	

Results:

Modulation	Power spectral density [dBm/3kHz]		
	2412 MHz	2437 MHz	2462 MHz
Frequency			
GFSK	Not required for hopping systems!		
Pi/4 DQPSK			
8DPSK			
Measurement uncertainty	± 1.5 dB		

9.3 Carrier frequency separation

Description:

Measurement of the carrier frequency separation of a hopping system. The carrier frequency separation is constant for all modulation-modes. We use GFSK-modulation to show compliance. EUT in hopping mode.

Measurement:

Measurement parameter	
Detector:	Peak
Sweep time:	Auto
Video bandwidth:	100 kHz
Resolution bandwidth:	100 kHz
Span:	4 MHz
Trace-Mode:	Max Hold

Limits:

FCC	IC
CFR Part 15.247 (a)(1)	RSS 210, Issue 8, A 8.1(b)
Carrier Frequency Separation	
Minimum 25 kHz or two-thirds of the 20 dB bandwidth of the hopping system whichever is greater.	

Result:

Carrier frequency separation	~ 1 MHz
------------------------------	---------

Result: [The measurement is passed.](#)

Plot:

Plot 1: Carrier frequency separation (GFSK modulation)

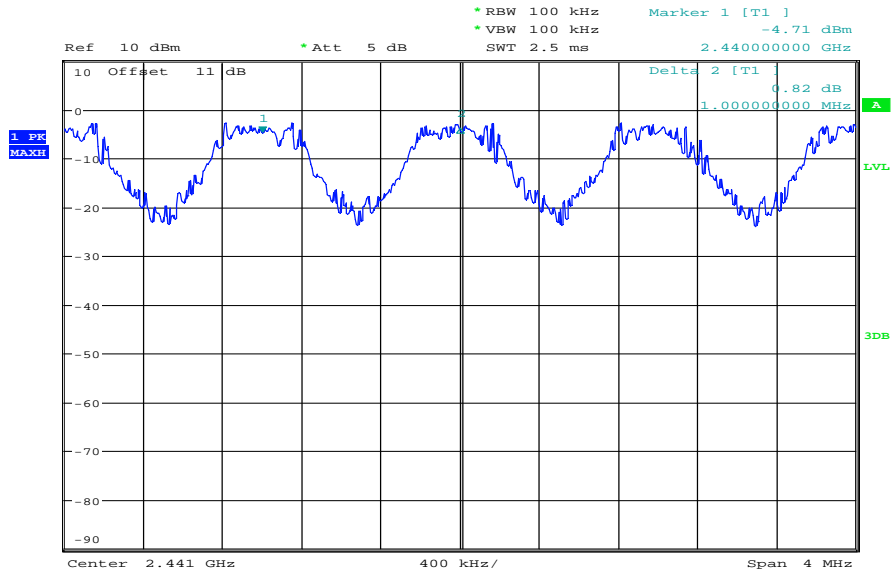

Date: 3.FEB.2012 10:08:07

9.4 Number of hopping channels

Description:

Measurement of the total number of used hopping channels. The number of hopping channels is constant for all modulation-modes. We use GFSK-modulation to show compliance. EUT in hopping mode.

Measurement:

Measurement parameter	
Detector:	Peak
Sweep time:	Auto
Video bandwidth:	500 kHz
Resolution bandwidth:	500 kHz
Span:	Plot 1: 2400 – 2445 MHz Plot 2: 2445 – 2485 MHz
Trace-Mode:	Max Hold

Limits:

FCC	IC
CFR Part 15.247 (a)(1)	RSS 210, Issue 8, A 8.1(d)
Number of hopping channels	
At least 15 non overlapping hopping channels	

Result:

Number of hopping channels	79
----------------------------	----

Result: The measurement is passed.

Plots:

Plot 1: Number of hopping channels (GFSK modulation)

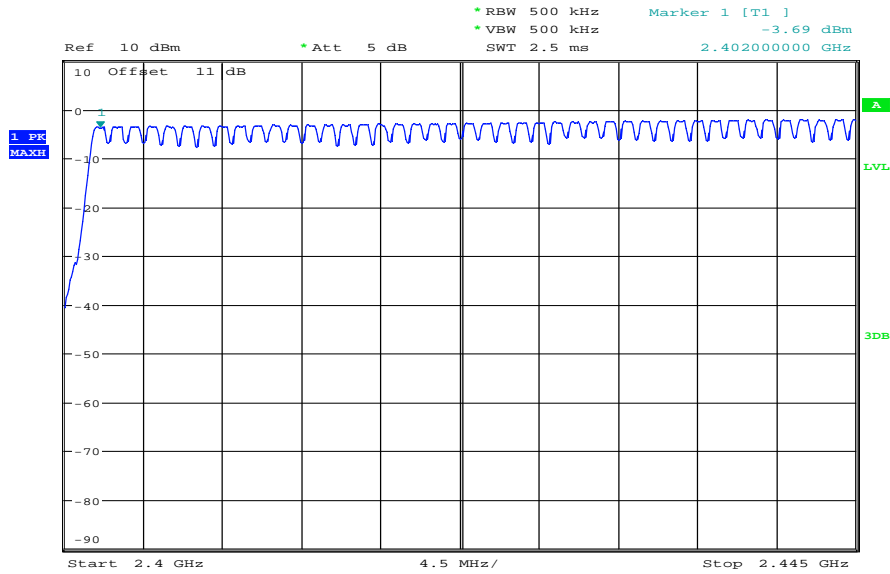

Date: 3.FEB.2012 10:12:10

Plot 2: Number of hopping channels (GFSK modulation)

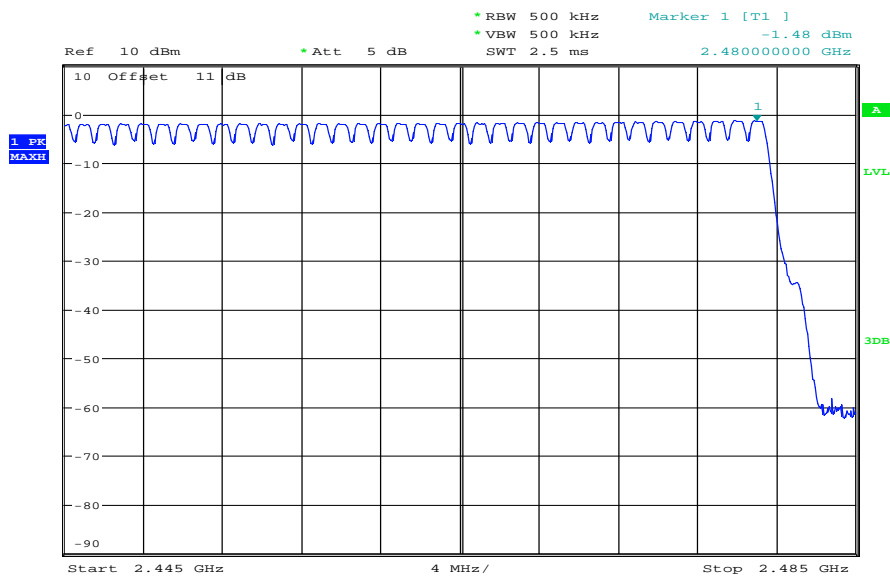

Date: 3.FEB.2012 10:20:11

9.5 Time of occupancy (dwell time)

Measurement:

For Bluetooth® devices no measurements mandatory depending on the fixed requirements according to the Bluetooth® Core Specifications!

For Bluetooth® devices:

The channel staying time of 0.4 s within a 31.6 second period in data mode is constant for Bluetooth® devices and independent from the packet type (packet length). The calculation for a 31.6 second period is as follows:

Channel staying time = time slot length * hop rate / number of hopping channels * 31.6 s

Example for a DH1 packet (with a maximum length of one time slot)
 Channel staying time = $625 \mu\text{s} * 1600 * 1/\text{s} / 79 * 31.6 \text{ s} = 0.4 \text{ s}$ (in a 31.6 s period)

For multi-slot packets the hopping is reduced according to the length of the packet.

Example for a DH3 packet (with a maximum length of three time slots)
 Channel staying time = $3 * 625 \mu\text{s} * 1600/3 * 1/\text{s} / 79 * 31.6 \text{ s} = 0.4 \text{ s}$ (in a 31.6 s period)

Example for a DH5 packet (with a maximum length of five time slots)
 Channel staying time = $5 * 625 \mu\text{s} * 1600/5 * 1/\text{s} / 79 * 31.6 \text{ s} = 0.4 \text{ s}$ (in a 31.6 s period)

This is according to the Bluetooth® Core Specification V2.0 & V2.1 & V3.0 & V4.0 (+ critical errata) for all Bluetooth® devices.

The following table shows the relations:

Packet Size	Pulse Width [ms] *	Max. number of transmissions per channel in 31.6 sec
DH1	0.366	640
DH3	1.622	214
DH5	2.870	128

* according to Bluetooth® specification

Results:

Packet Size	Pulse Width [ms]*	Max. number of transmissions in 31.6 sec	Dwell time [Pulse width * Number of transmissions]
DH1	0.366	640	234.2 ms
DH3	1.622	214	347.1 ms
DH5	2.870	128	367.4 ms

Limits:

FCC	IC
CFR Part 15.247 (a)(1)(iii)	RSS 210, Issue 8, A 8.3(1)
Time of occupancy (dwell time)	
The frequency hopping operation shall have an average time of occupancy on any frequency not exceeding 0.4 seconds within a duration in seconds equal to the number of hopping frequencies multiplied by 0.4.	

Result: The measurement is passed.

9.6 Spectrum bandwidth of a FHSS system – 20 dB bandwidth

Description:

Measurement of the 20dB bandwidth of the modulated signal. The measurement is performed according to the "Measurement Guidelines" (DA 00-705, March 30, 2000). EUT in single channel mode.

Measurement:

Measurement parameter	
Detector:	Peak
Sweep time:	2 s
Video bandwidth:	30 kHz
Resolution bandwidth:	30 kHz
Span:	3 MHz
Trace-Mode:	Max Hold

Limits:

FCC	IC
CFR Part 15.247 (a)(1)	RSS 210, Issue 8, A 8.2(a)
Spectrum bandwidth of a FHSS system – 20 dB bandwidth	
GFSK < 1500 kHz Pi/4 DQPSK < 1500 kHz 8DPSK < 1500 kHz	

Results:

Modulation	20 dB BANDWIDTH [kHz]		
	2402 MHz	2441 MHz	2480 MHz
Frequency			
GFSK	803	774	803
Pi/4 DQPSK	1125	1120	1120
8DPSK	1188	1159	1164
Measurement uncertainty	± 30 kHz		

Result: The measurement is passed.

Plots:

Plot 1: lowest channel – 2402 MHz, GFSK modulation

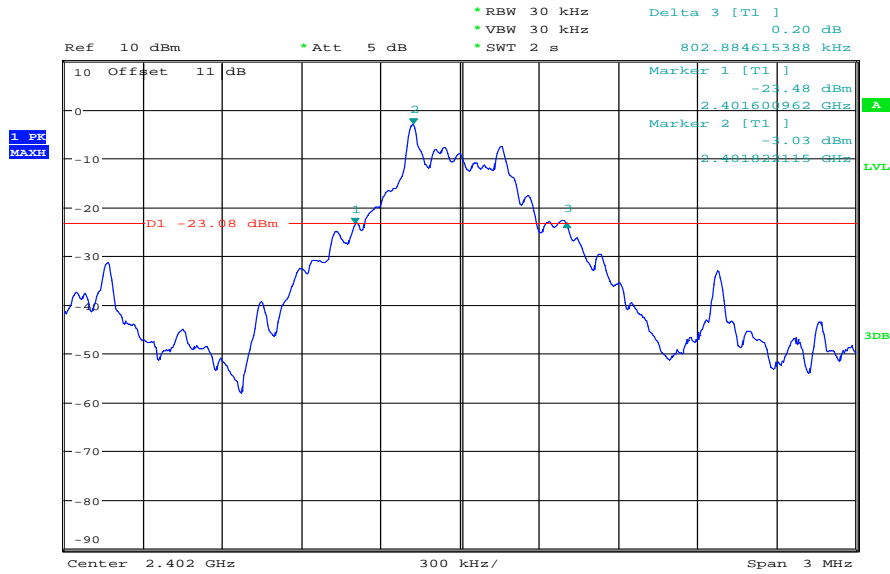

Date: 26.JAN.2012 08:38:41

Plot 2: middle channel – 2441 MHz, GFSK modulation

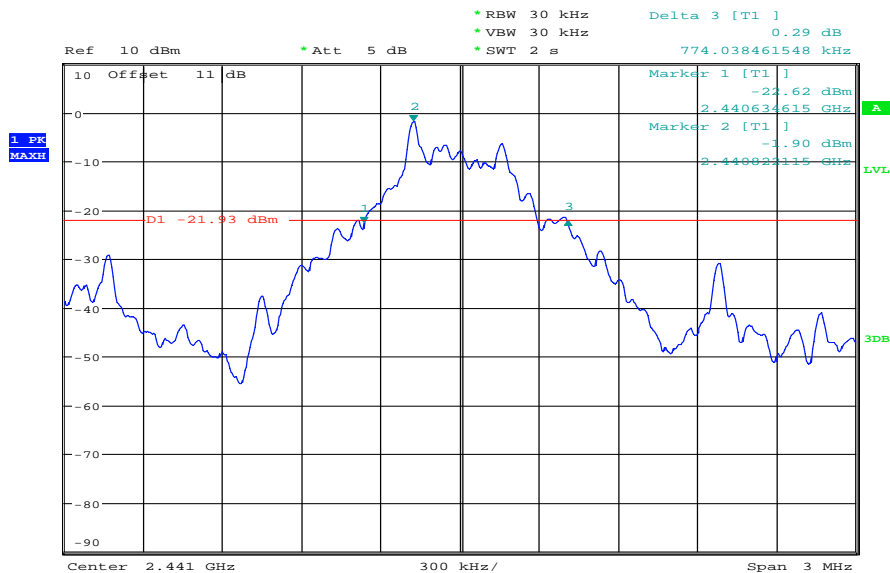

Date: 26.JAN.2012 08:43:50

Plot 3: highest channel – 2480 MHz, GFSK modulation

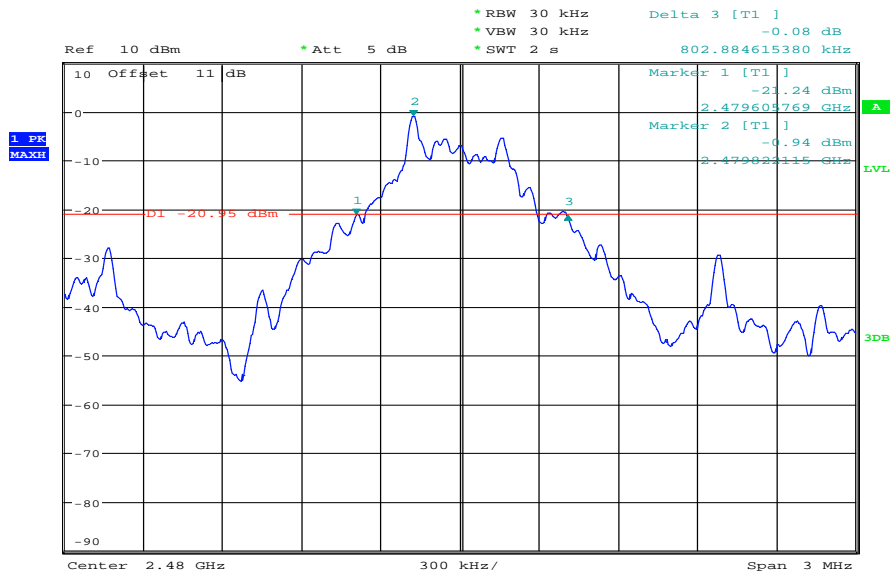

Date: 26.JAN.2012 08:47:39

Plot 4: lowest channel – 2402 MHz, Pi / DQPSK modulation

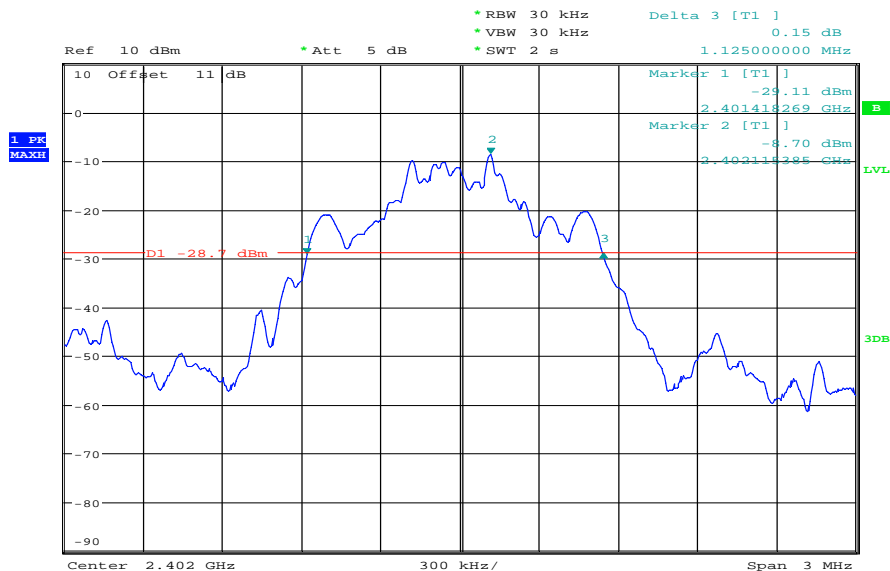

Date: 3.FEB.2012 10:39:19

Plot 5: middle channel – 2441 MHz, Pi / DQPSK modulation

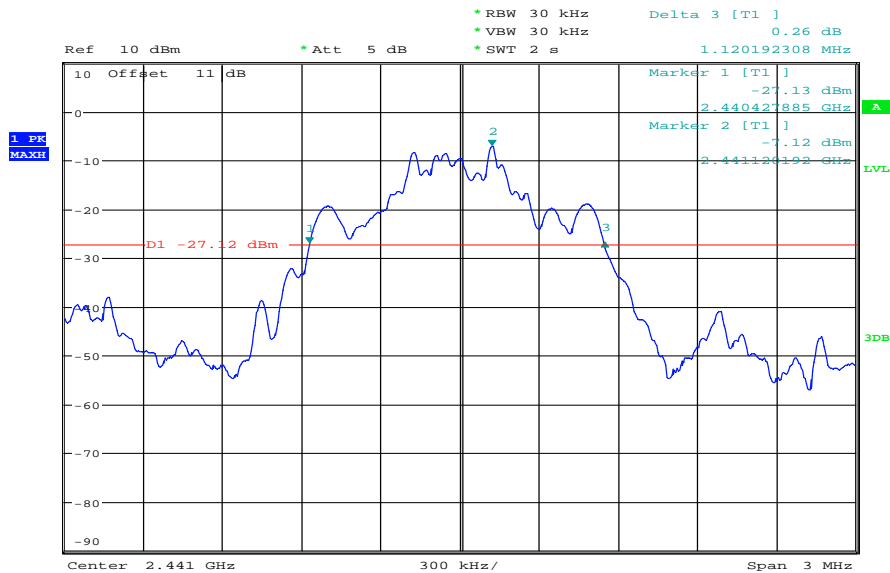

Date: 26.JAN.2012 08:45:10

Plot 6: highest channel – 2480 MHz, Pi / DQPSK modulation

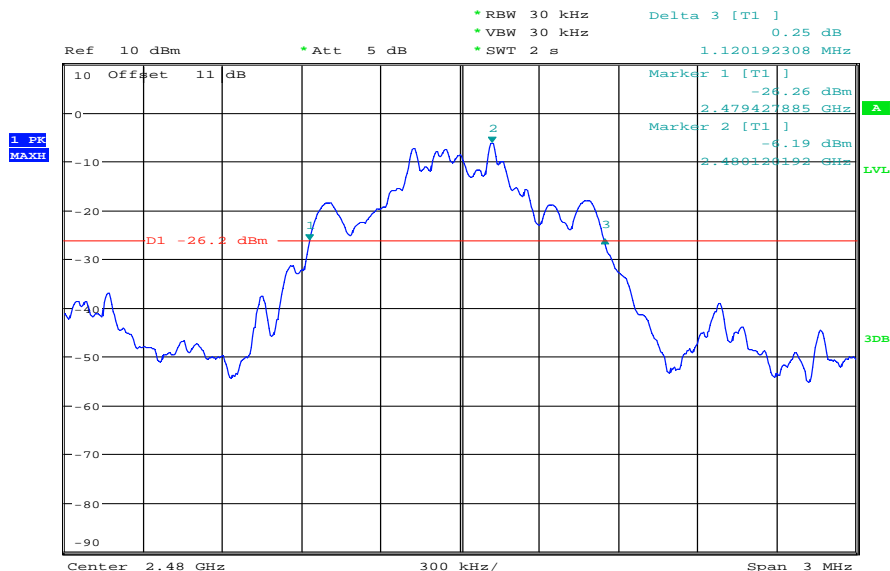

Date: 26.JAN.2012 08:48:33

Plot 7: lowest channel – 2402 MHz, 8 DPSK modulation

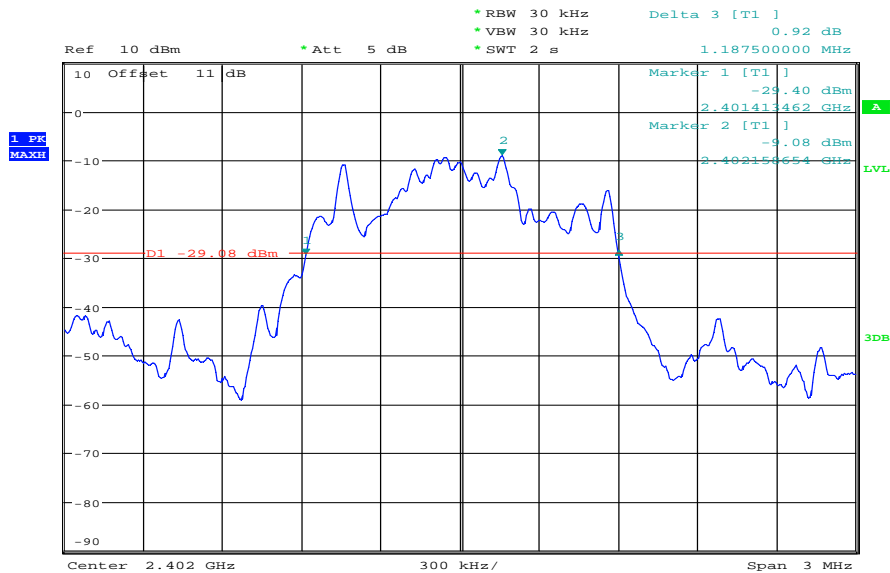

Date: 26.JAN.2012 08:24:43

Plot 8: middle channel – 2441 MHz, 8 DPSK modulation

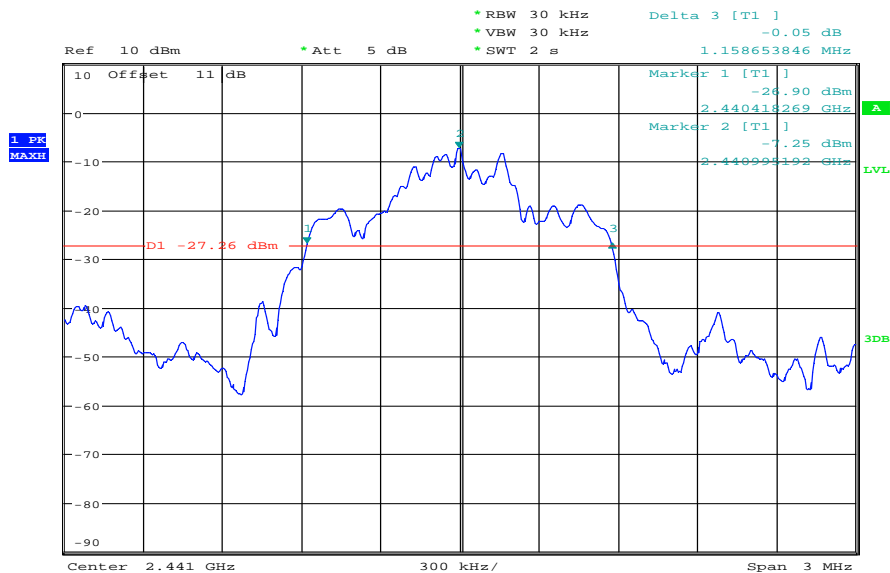

Date: 26.JAN.2012 08:46:06

Plot 9: highest channel – 2480 MHz, 8 DPSK modulation

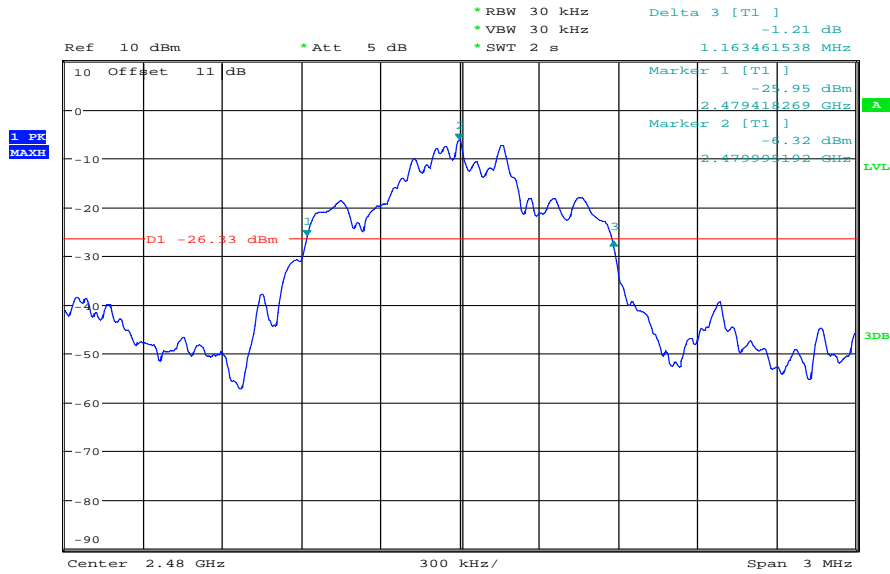

Date: 26.JAN.2012 08:53:34

9.7 Maximum output power

Description:

Measurement of the maximum output power conducted and radiated. EUT in single channel mode.

Measurement:

Measurement parameter	
Detector:	Peak
Sweep time:	Auto
Video bandwidth:	3 MHz
Resolution bandwidth:	3 MHz
Span:	3 MHz
Trace-Mode:	Max Hold

Limits:

FCC	IC
CFR Part 15.247 (b)(1)	RSS 210, Issue 8, A 8.4(2)
Maximum output power	
[Conducted: 0.125 W – antenna gain max. 6 dBi] Systems using more than 75 hopping channels: Conducted: 1.0 W – antenna gain max. 6 dBi	

Results:

Modulation Frequency	Maximum output power conducted [dBm]		
	2402 MHz	2441 MHz	2480 MHz
GFSK	-2.49	-1.45	-0.45
Pi/4 DQPSK	-4.28	-3.42	-2.43
8DPSK	-0.45	-2.43	-2.43
Measurement uncertainty	± 1 dB		

Result: The measurement is passed.

Results:

Modulation Frequency	Maximum output power radiated - EIRP [dBm]		
	2402 MHz	2441 MHz	2480 MHz
GFSK	-/-	-/-	-/-
Pi/4 DQPSK *)	-/-	-/-	-/-
8DPSK *)	-/-	-/-	-/-
Measurement uncertainty	± 3 dB		

*) - Values calculated with antenna gain

Result: Not performed!

Plots:

Plot 1: lowest channel – 2402 MHz, GFSK modulation

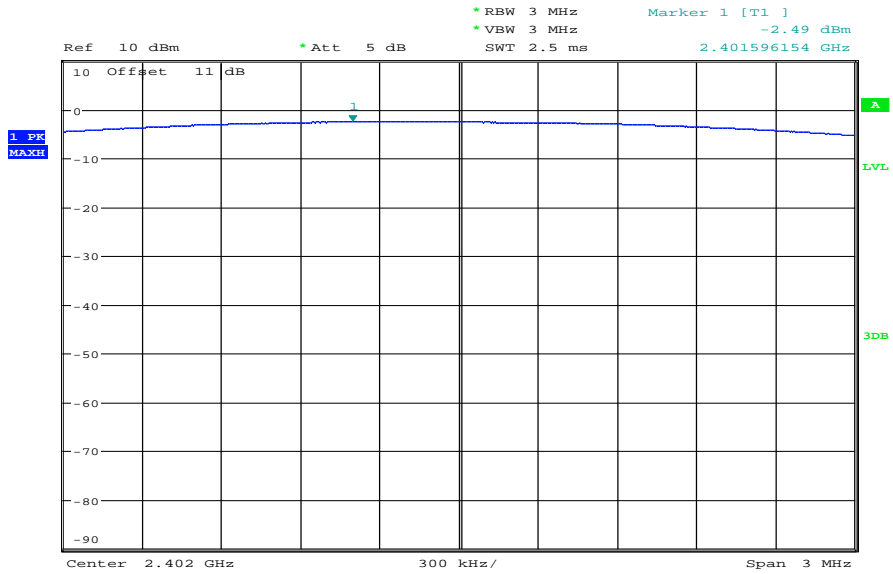

Date: 26.JAN.2012 07:37:43

Plot 2: middle channel – 2441 MHz, GFSK modulation

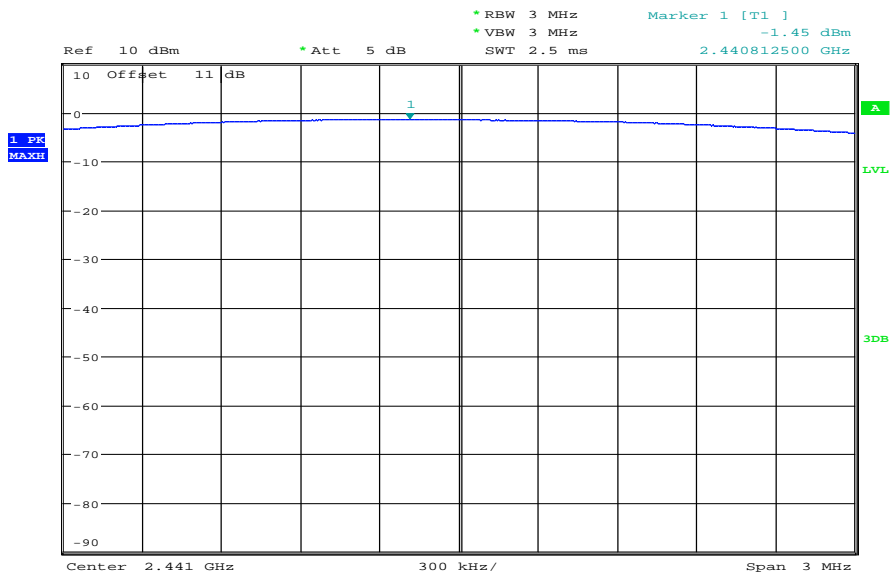

Date: 26.JAN.2012 08:03:45

Plot 3: highest channel – 2480 MHz, GFSK modulation

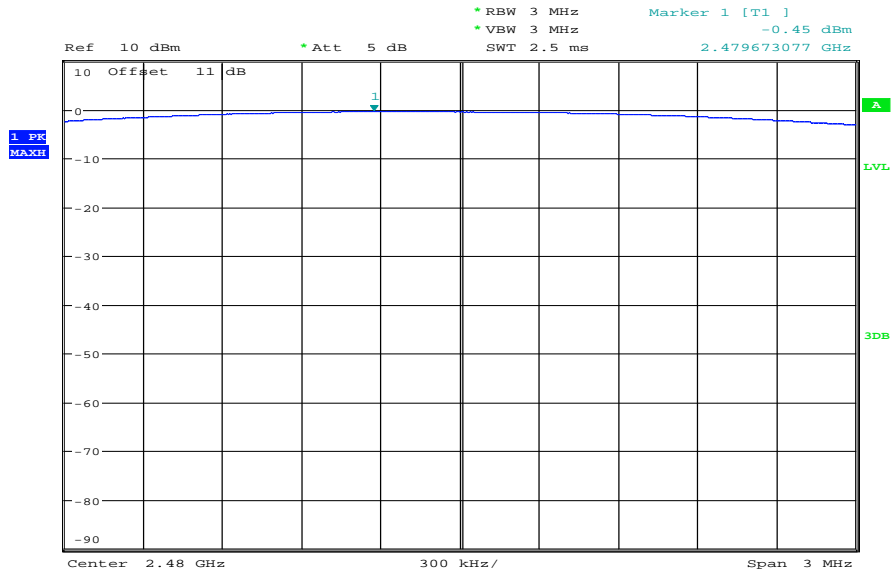

Date: 26.JAN.2012 08:05:09

Plot 4: lowest channel – 2402 MHz, Pi / DQPSK modulation

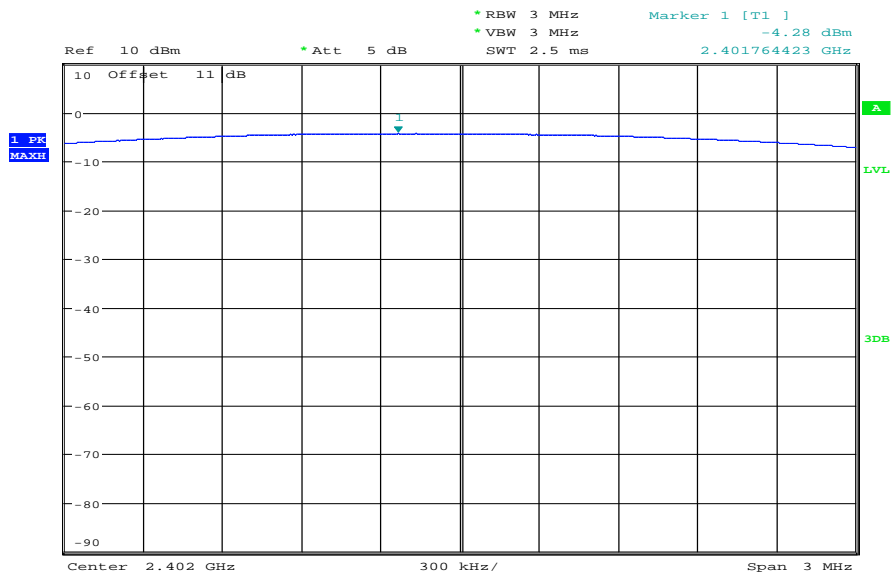

Date: 26.JAN.2012 08:09:01

Plot 5: middle channel – 2441 MHz, Pi / DQPSK modulation

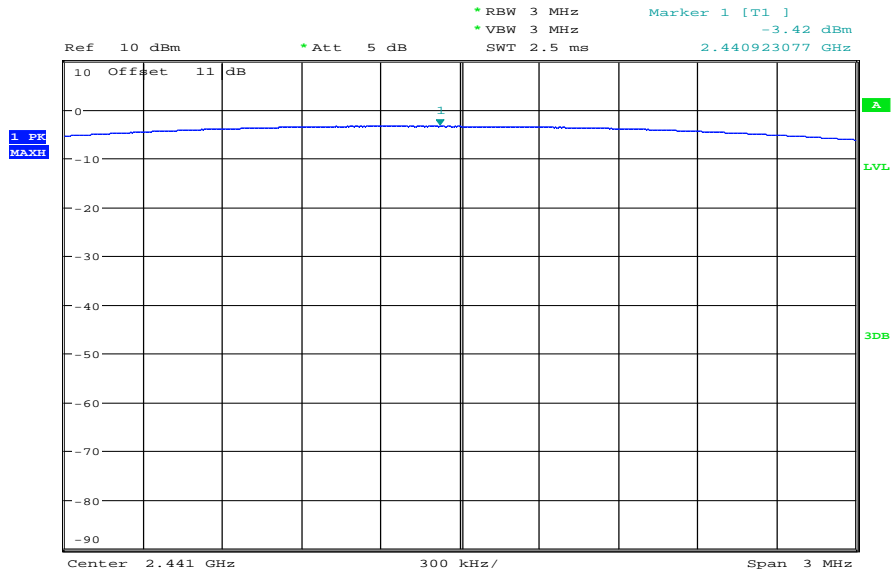

Date: 26.JAN.2012 08:07:08

Plot 6: highest channel – 2480 MHz, Pi / DQPSK modulation

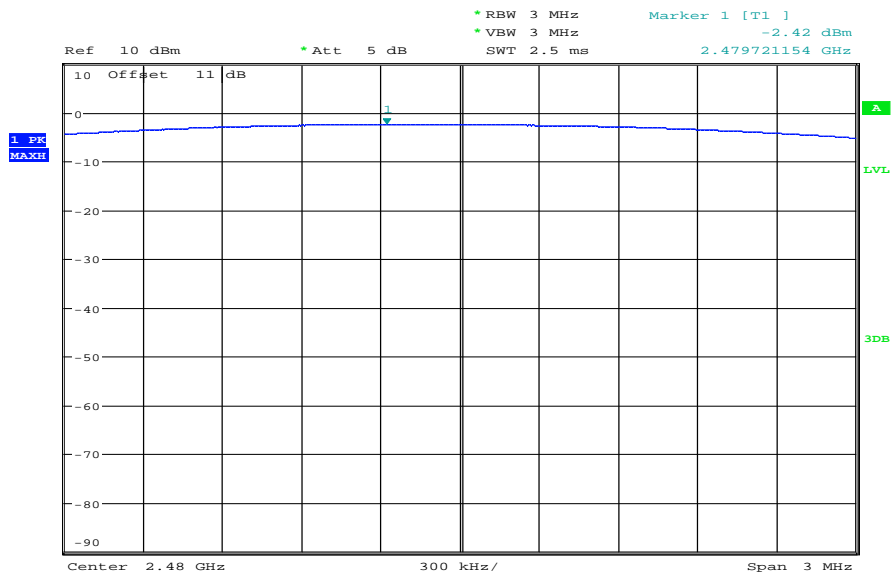

Date: 26.JAN.2012 08:05:57

Plot 7: lowest channel – 2402 MHz, 8 DPSK modulation

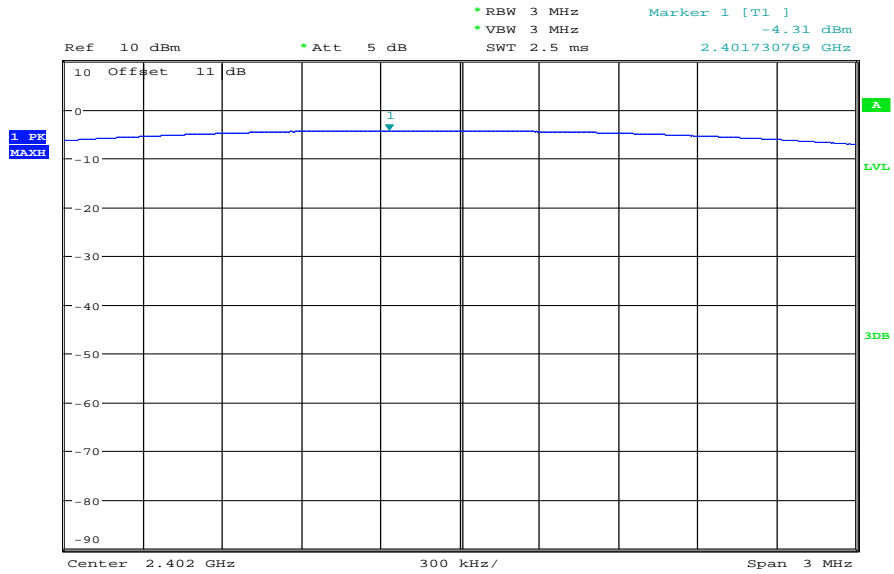

Date: 26.JAN.2012 08:09:38

Plot 8: middle channel – 2441 MHz, 8 DPSK modulation

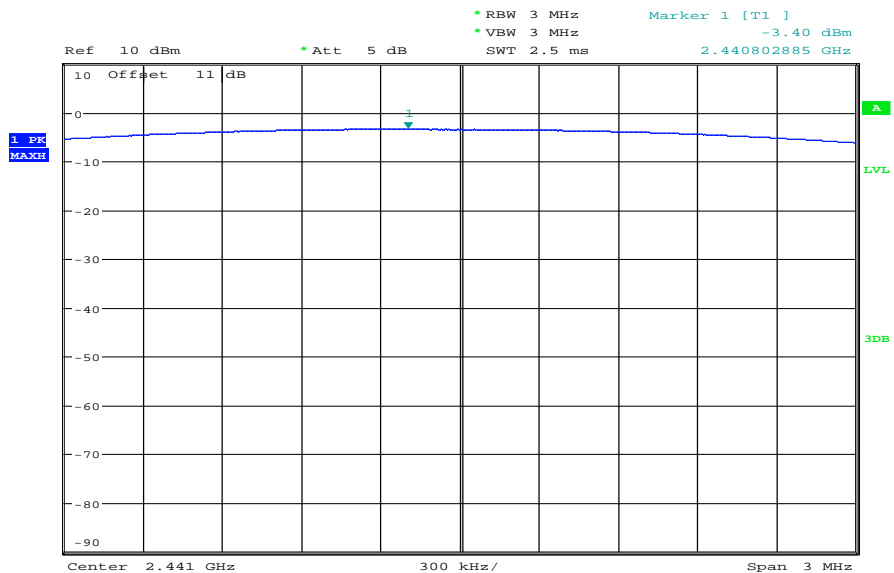

Date: 26.JAN.2012 08:07:57

Plot 9: highest channel – 2480 MHz, 8 DPSK modulation

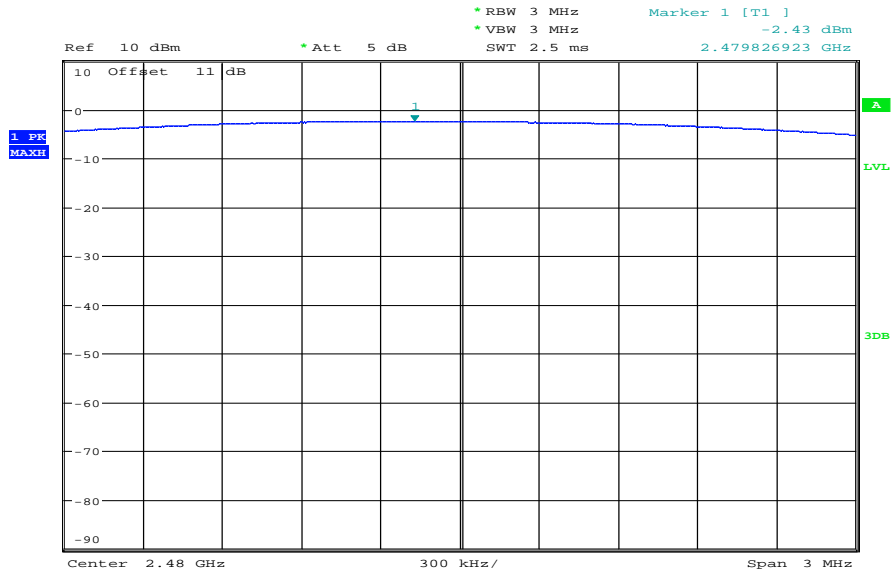

Date: 26.JAN.2012 08:06:31

9.8 Band edge compliance conducted

Description:

Measurement of the conducted band edge compliance. EUT is measured at the lower and upper band edge in single channel and hopping mode. The measurement is repeated for all modulations.

Measurement:

Measurement parameter	
Detector:	Peak
Sweep time:	Auto
Video bandwidth:	100 kHz
Resolution bandwidth:	100 kHz
Span:	Lower Band Edge: 2395 – 2405 MHz Higher Band Edge: 2478 – 2489 MHz
Trace-Mode:	Max Hold

Limits:

FCC	IC
CFR Part 15.247 (d)	RSS 210, Issue 8, A 8.5
Band edge compliance conducted	
<p>In any 100 kHz bandwidth outside the frequency band in which the spread spectrum or digitally modulated intentional radiator is operating, the radio frequency power that is produced by the intentional radiator shall be at least 20 dB below that in the 100 kHz bandwidth within the band that contains the highest level of the desired power, based on either an RF conducted or a radiated measurement. Attenuation below the general limits specified in Section 15.209(a) is not required.</p>	

Results:

Scenario Modulation	Band edge compliance conducted [dB]		
	GFSK	Pi/4 DQPSK	8DPSK
Lower band edge – hopping off	> 20 dB	> 20 dB	> 20 dB
Lower band edge – hopping on	> 20 dB	> 20 dB	> 20 dB
Upper band edge – hopping off	> 20 dB	> 20 dB	> 20 dB
Upper band edge – hopping on	> 20 dB	> 20 dB	> 20 dB
Measurement uncertainty	± 1.5 dB		

Result: The measurement is passed.

Plots:

Plot 1: Lower band edge – hopping on, GFSK modulation

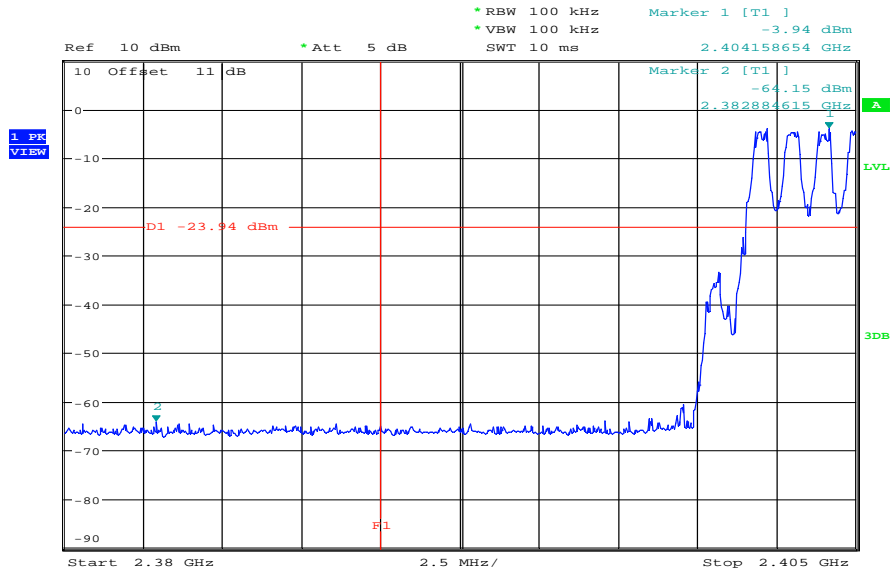

Date: 3.FEB.2012 10:04:02

Plot 2: Upper band edge – hopping on, GFSK modulation

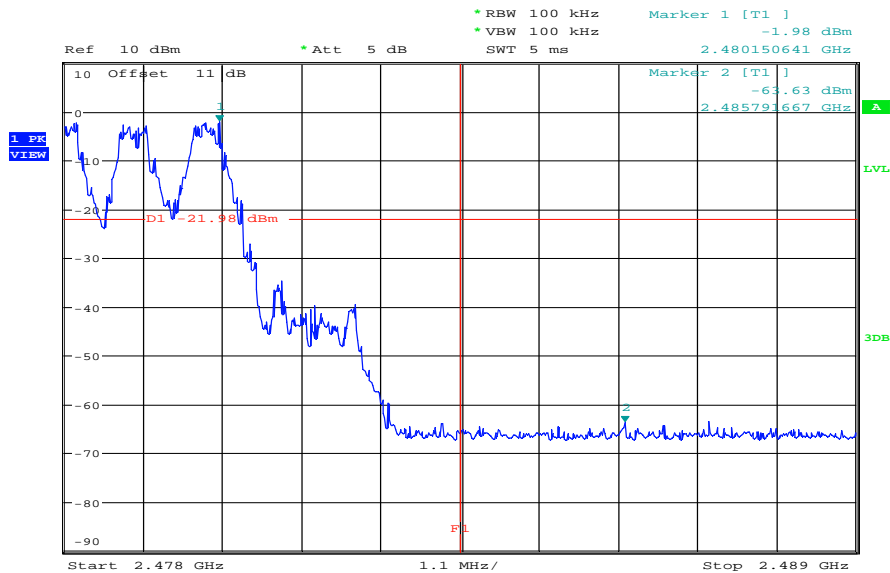

Date: 3.FEB.2012 09:20:12

Plot 3: Lower band edge – hopping off, GFSK modulation

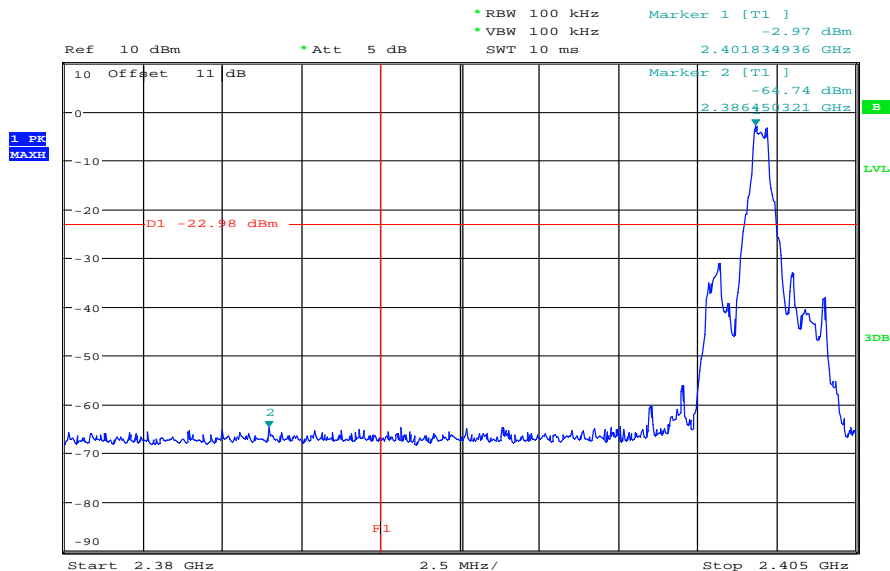

Date: 26.JAN.2012 08:39:20

Plot 4: Upper band edge – hopping off, GFSK modulation

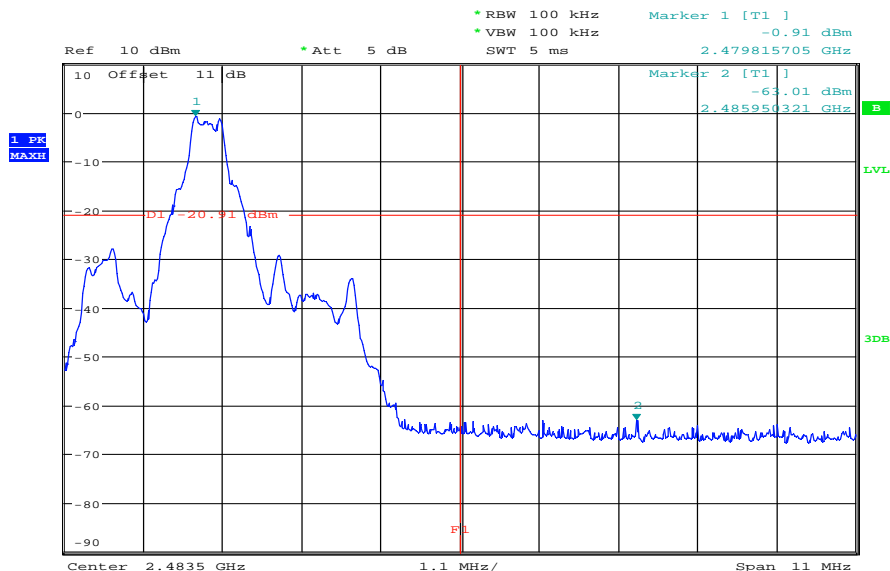

Date: 26.JAN.2012 08:51:40

Plot 5: Lower band edge – hopping on, Pi/4 DQPSK modulation

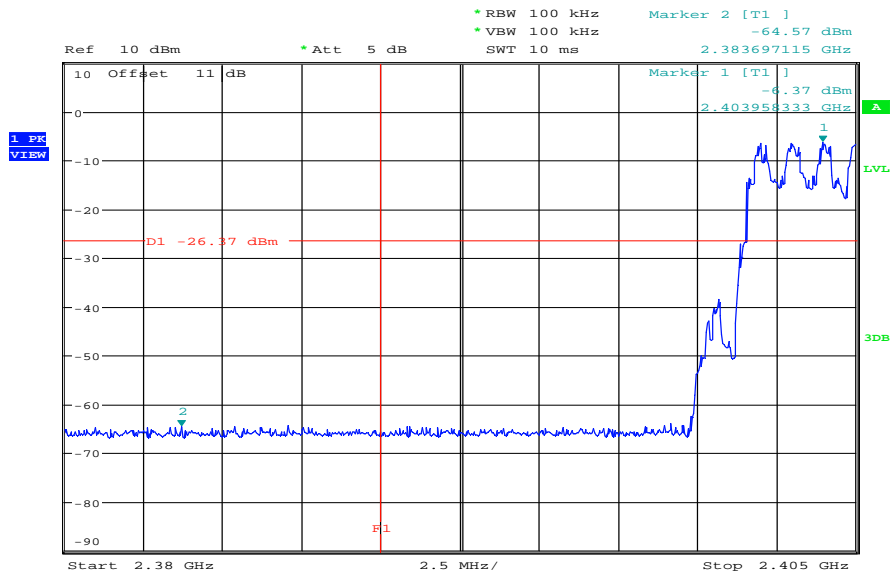

Date: 3.FEB.2012 09:48:49

Plot 6: Upper band edge – hopping on, Pi/4 DQPSK modulation

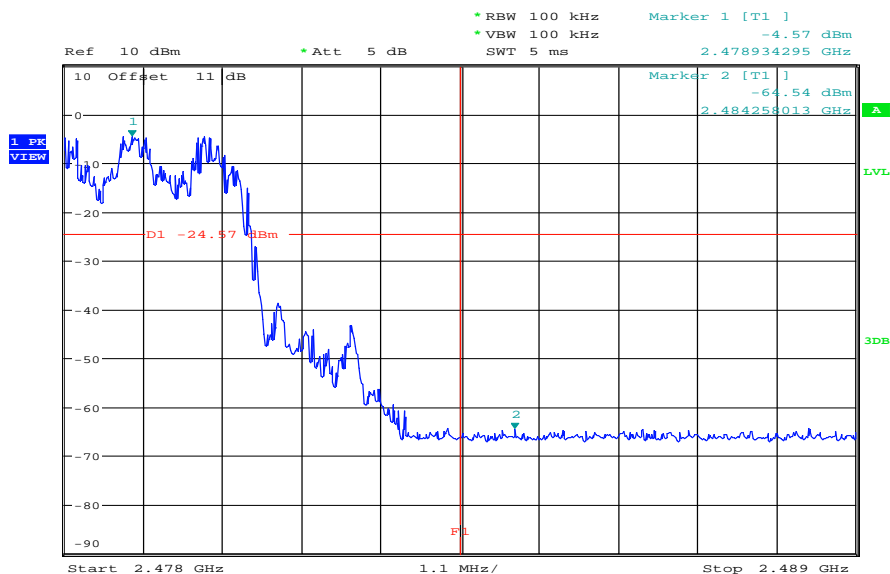

Date: 3.FEB.2012 09:26:32

Plot 7: Lower band edge – hopping off, Pi/4 DQPSK modulation

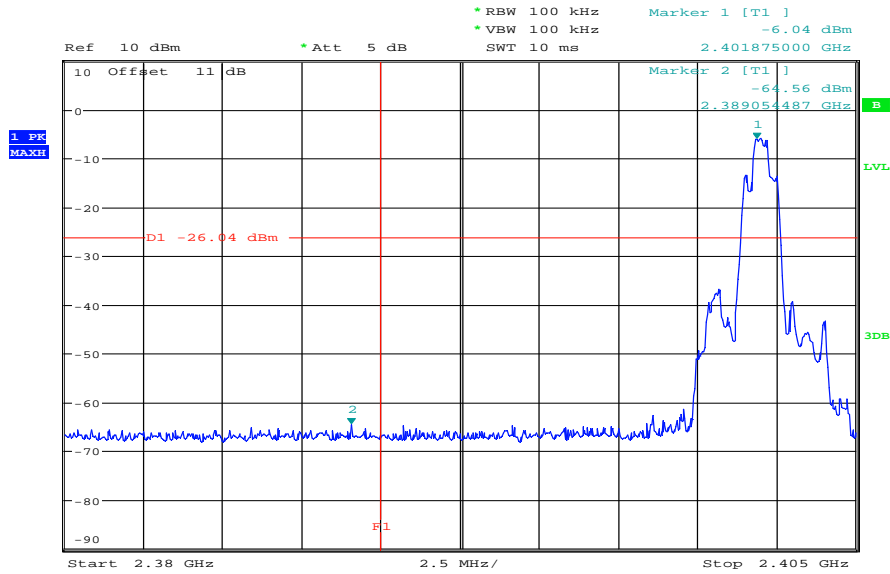

Date: 26.JAN.2012 08:40:33

Plot 8: Upper band edge – hopping off, Pi/4 DQPSK modulation

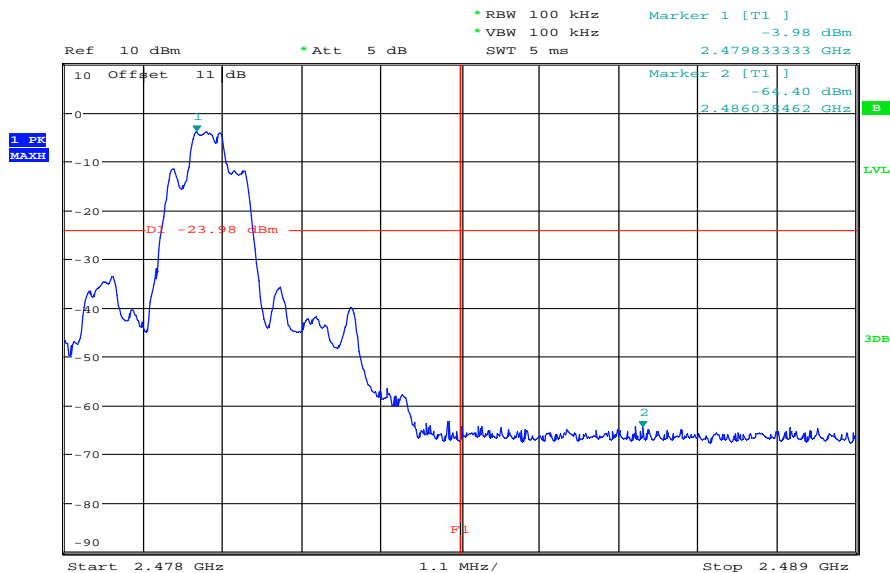

Date: 26.JAN.2012 08:50:26

Plot 9: Lower band edge – hopping on, 8DPSK modulation

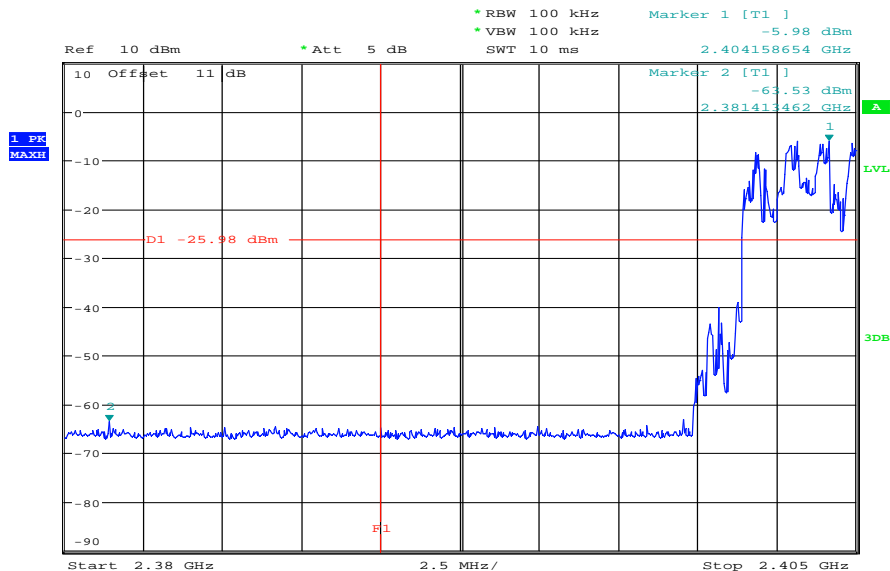

Date: 3.FEB.2012 09:39:03

Plot 10: Upper band edge – hopping on, 8DPSK modulation

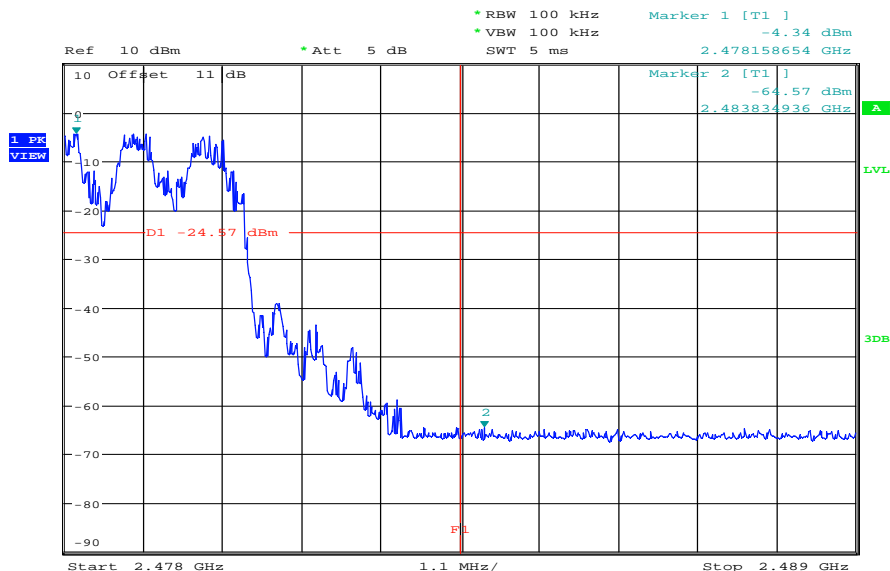

Date: 3.FEB.2012 09:32:16

Plot 11: Lower band edge – hopping off, 8DPSK modulation

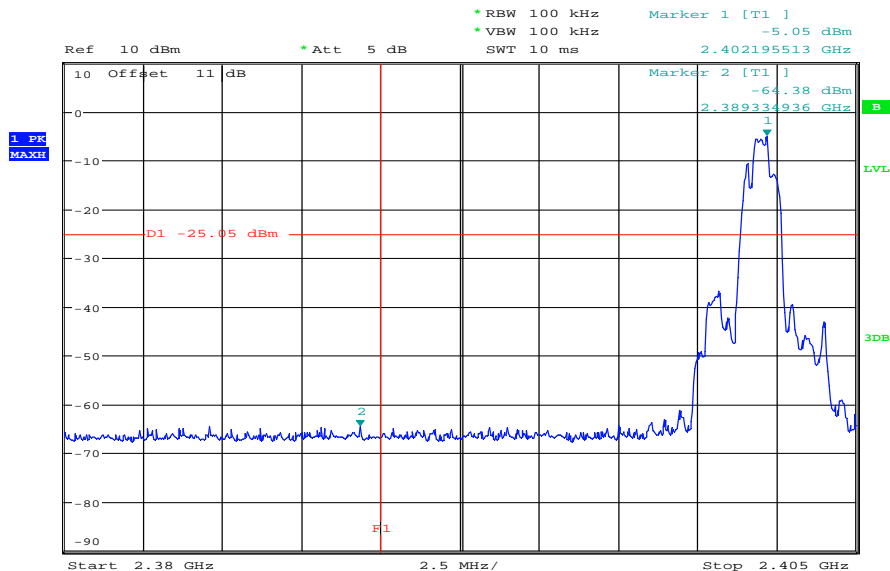

Date: 26.JAN.2012 08:22:07

Plot 12: Upper band edge – hopping off, 8DPSK modulation

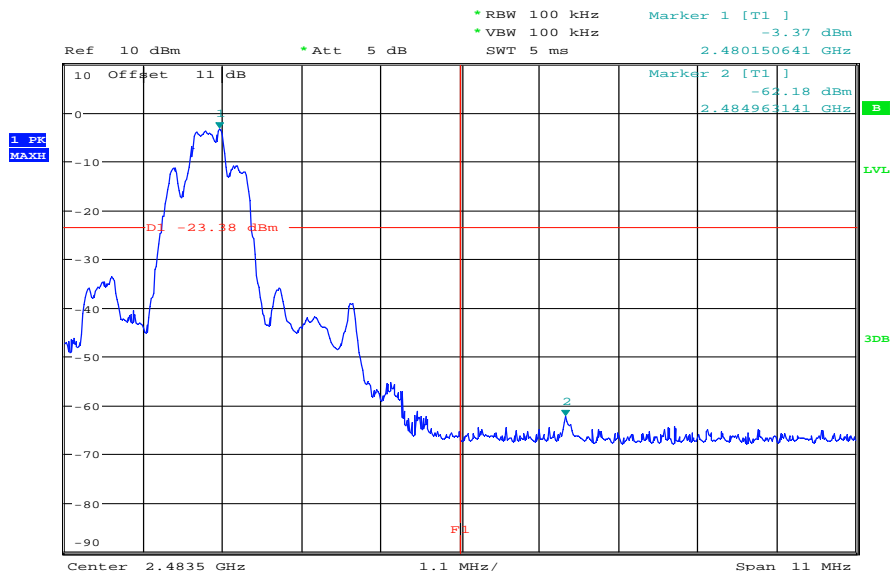

Date: 26.JAN.2012 08:52:47

9.9 Band edge compliance radiated

Description:

Measurement of the radiated band edge compliance. The EUT is turned in the position that results in the maximum level at the band edge. Then a sweep over the corresponding restricted band is performed. The EUT is set to single channel mode and the transmit channel is channel 00 for the lower restricted band and channel 78 for the upper restricted band. The measurement is repeated for all modulations. Measurement distance is 3m.

Measurement:

Measurement parameter	
Detector:	Peak
Sweep time:	Auto
Video bandwidth:	10 Hz
Resolution bandwidth:	1 MHz
Span:	Lower Band: 2300 – 2400 MHz Higher Band: 2480 – 2500 MHz
Trace-Mode:	Max Hold

Limits:

FCC	IC
CFR Part 15.205	RSS 210, Issue 8, A 8.5
Band edge compliance radiated	
<p>In any 100 kHz bandwidth outside the frequency band in which the spread spectrum or digitally modulated intentional radiator is operating, the radio frequency power that is produced by the intentional radiator shall be at least 20 dB below that in the 100 kHz bandwidth within the band that contains the highest level of the desired power, based on either an RF conducted or a radiated measurement. Attenuation below the general limits specified in Section 15.209(a) is not required. In addition, radiated emissions which fall in the restricted bands, as defined in Section 15.205(a), must also comply with the radiated emission limits specified in Section 15.209(a) (see Section 5.205(c)).</p>	
54 dBµV/m AVG	

Results: Also see plots

Scenario Modulation	Band edge compliance radiated [dBµV/m]		
	GFSK	Pi/4 DQPSK	8DPSK
Lower restricted band	< 54 (see plot 1/3)	< 54 (see plot 5/7)	< 54 (see plot 9/11)
Upper restricted band	< 54 (see plot 2/4)	< 54 (see plot 6/8)	< 54 (see plot 10/12)
Measurement uncertainty	± 3 dB		

Result: The measurement is passed.

Plots:

Plot 1: GFSK modulation, lower band edge, vertical polarization

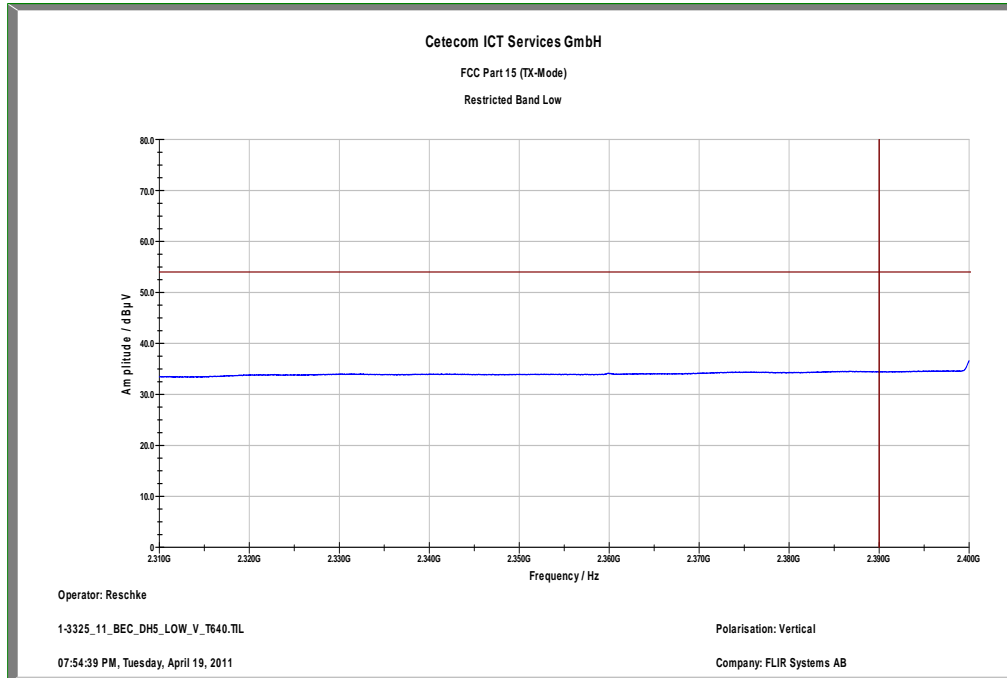

Plot 2: GFSK modulation, upper band edge, vertical polarization

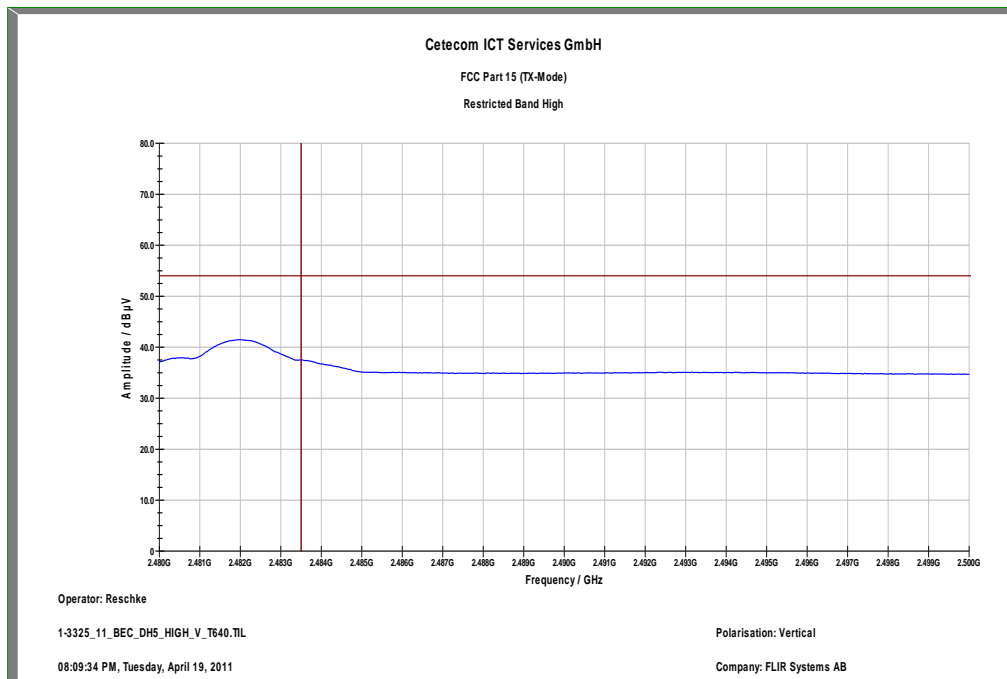

Plot 3: GFSK modulation, lower band edge, horizontal polarization

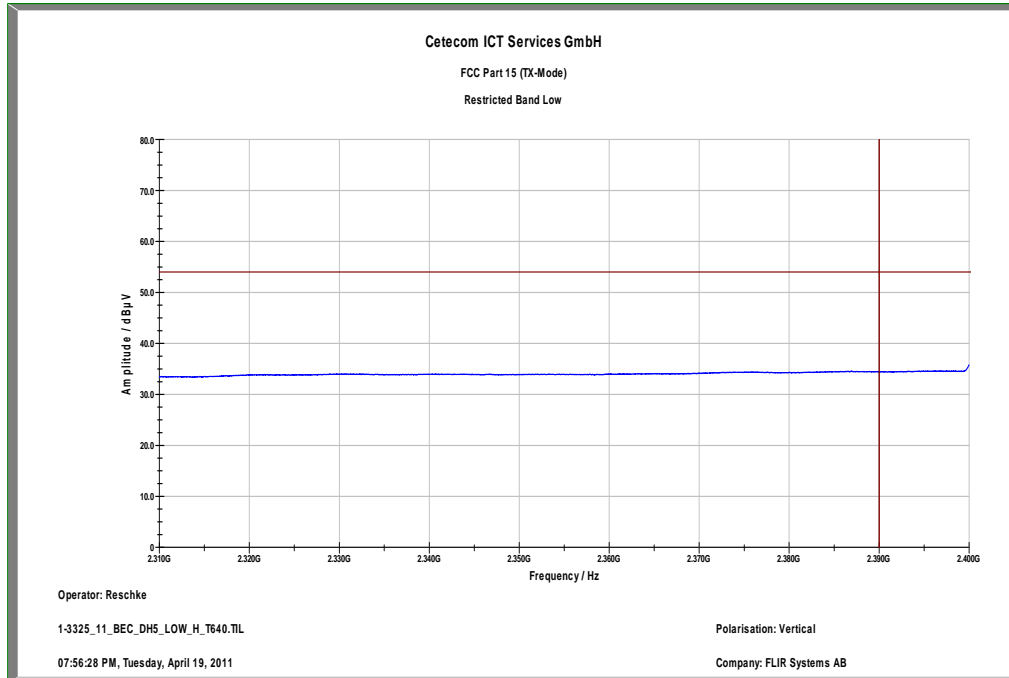

Plot 4: GFSK modulation, upper band edge, horizontal polarization

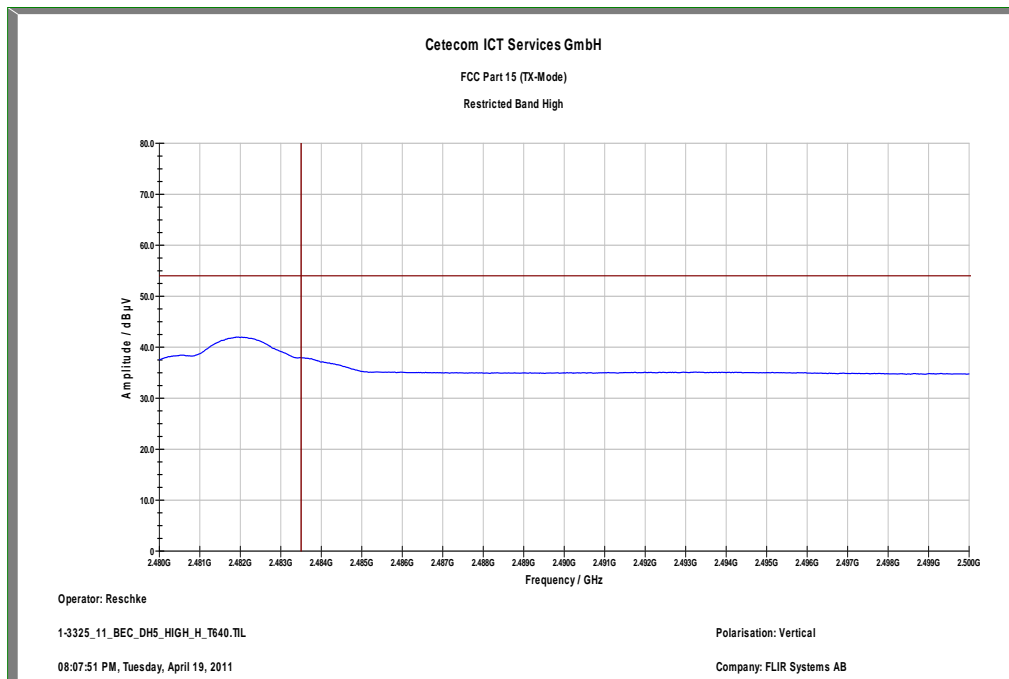

Plot 5: Pi/4 DQPSK modulation, lower band edge, vertical polarization

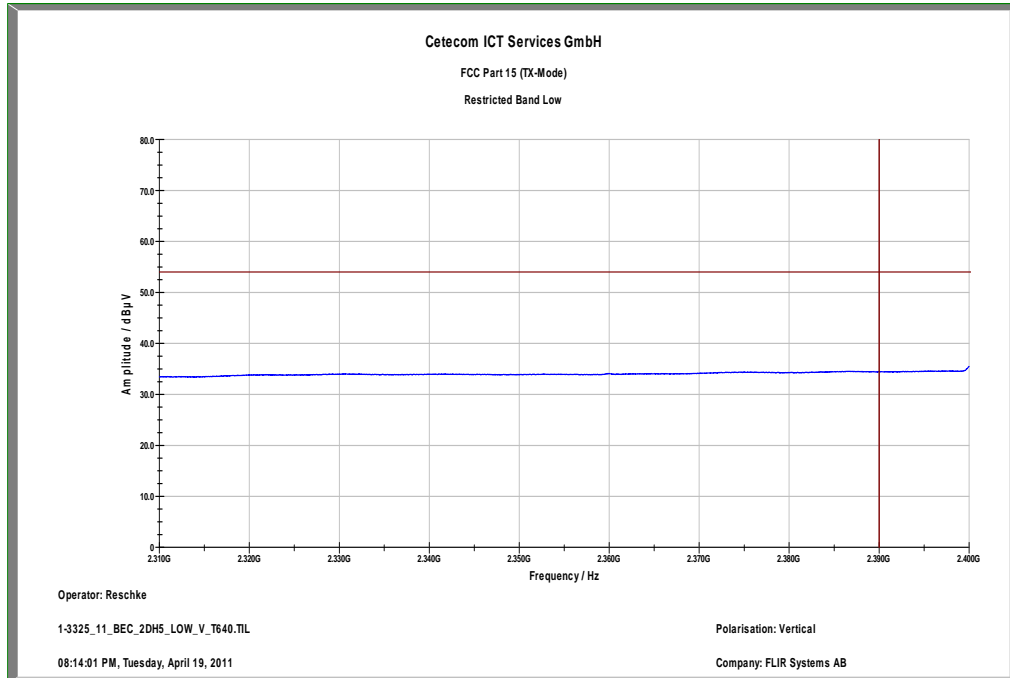

Plot 6: Pi/4 DQPSK modulation, upper band edge, vertical polarization

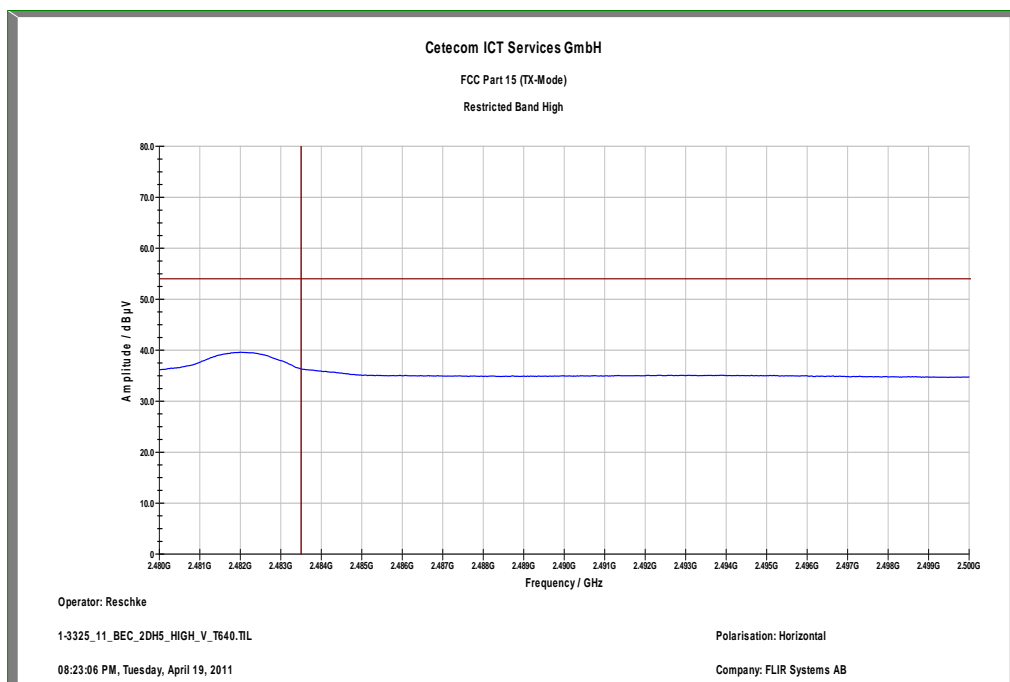

Plot 7: Pi/4 DQPSK modulation, lower band edge, horizontal polarization

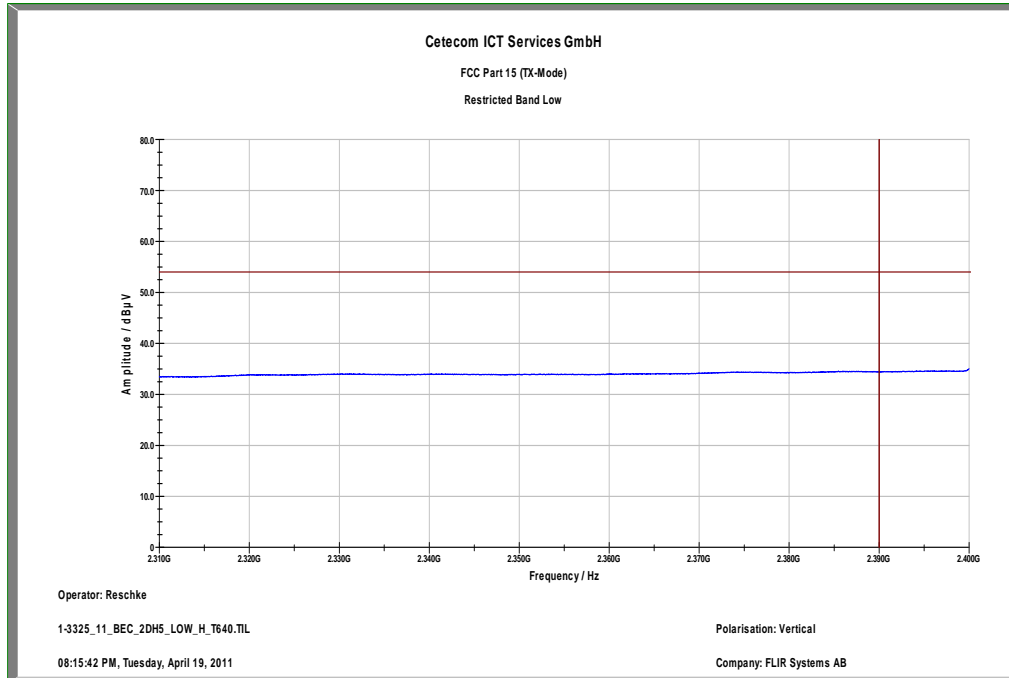

Plot 8: Pi/4 DQPSK modulation, upper band edge, horizontal polarization

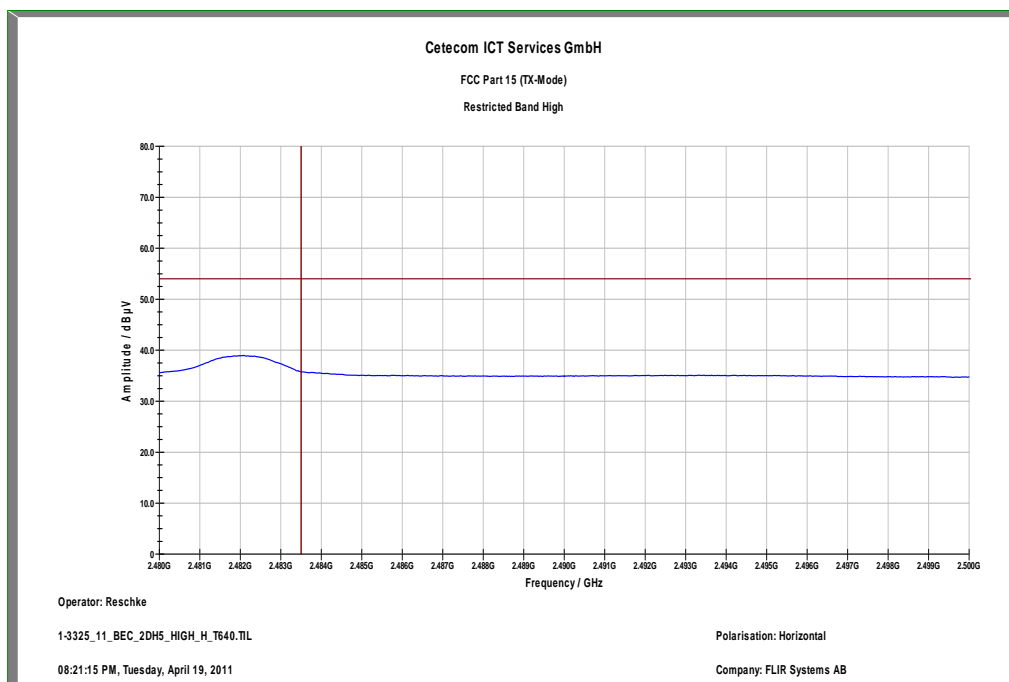

Plot 9: 8 DPSK modulation, lower band edge, vertical polarization

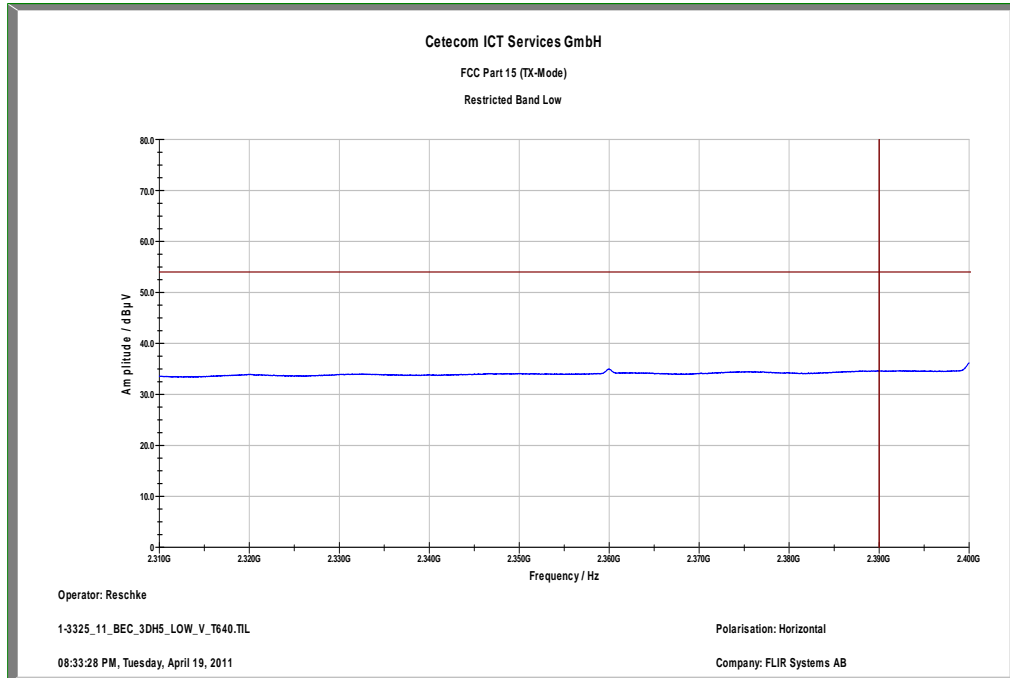

Plot 10: 8 DPSK modulation, upper band edge, vertical polarization

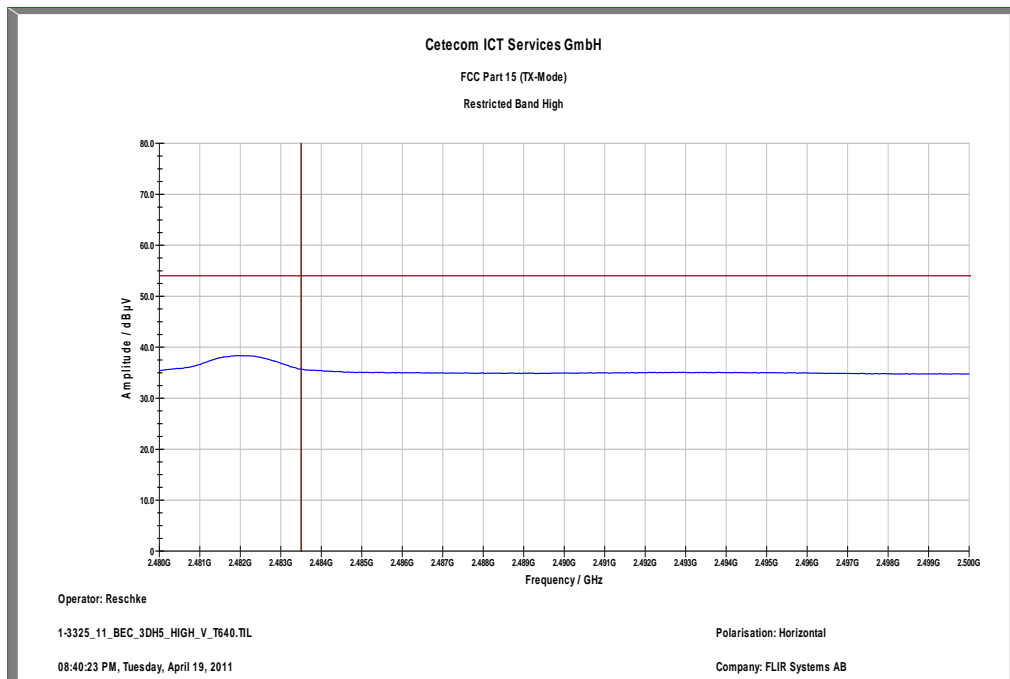

Plot 11: 8 DPSK modulation, lower band edge, horizontal polarization

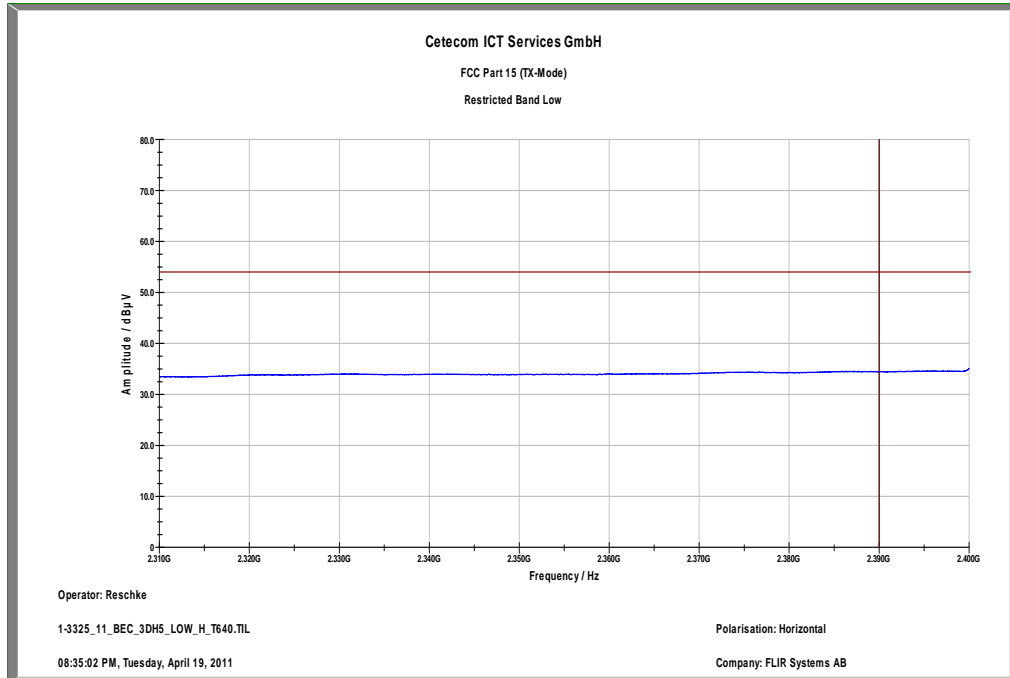

Plot 12: 8 DPSK modulation, upper band edge, horizontal polarization

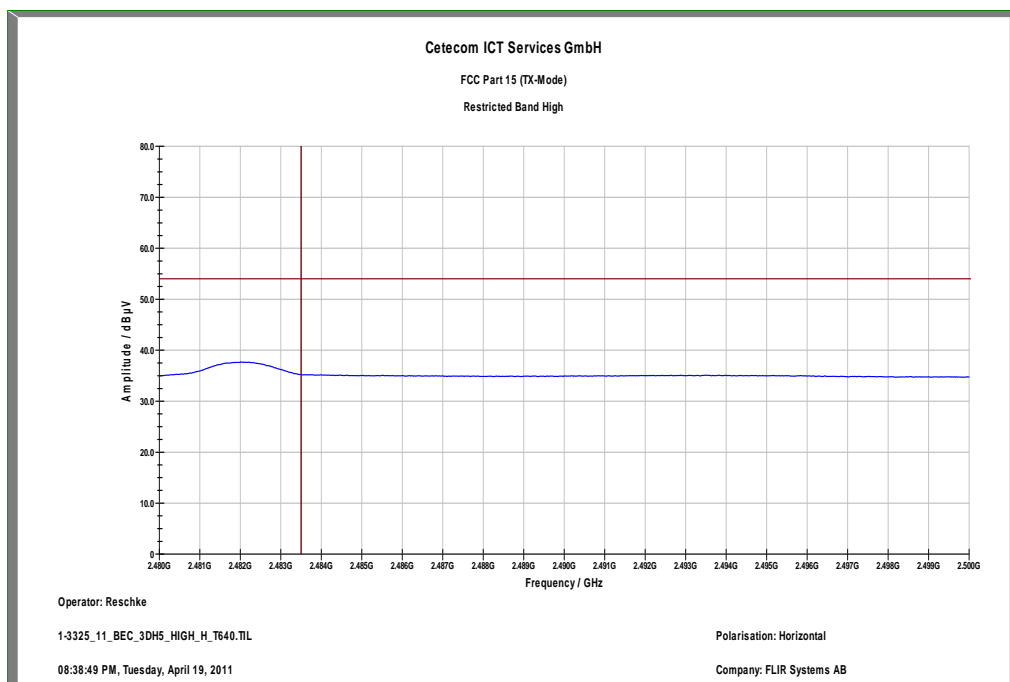

9.10 TX spurious emissions conducted

Description:

Measurement of the conducted spurious emissions in transmit mode. The EUT is set to single channel mode and the transmit channel is channel 00, channel 39 and channel 78. The measurement is repeated for all modulations.

Measurement:

Measurement parameter	
Detector:	Peak
Sweep time:	≥10s/GHz
Video bandwidth:	500 kHz
Resolution bandwidth:	100 kHz
Span:	9 kHz to 25 GHz
Trace-Mode:	Max Hold

Limits:

FCC	IC
CFR Part 15.247(d)	RSS 210, Issue 8, A 8.5
TX spurious emissions conducted	
<p>In any 100 kHz bandwidth outside the frequency band in which the spread spectrum or digitally modulated intentional radiator is operating, the radio frequency power that is produced by the intentional radiator shall be at least 20 dB below that in the 100 kHz bandwidth within the band that contains the highest level of the desired power, based on either an RF conducted or a radiated measurement. Attenuation below the general limits specified in Section 15.209(a) is not required</p>	

Results:

TX spurious emissions conducted					
GFSK - mode					
f [MHz]		amplitude of emission [dBm]	limit max. allowed emission power	actual attenuation below frequency of operation [dB]	results
2402		-4.21	30 dBm		Operating frequency
<i>No critical peaks detected</i>			-20 dBc		complies
2441		-3.31	30 dBm		Operating frequency
<i>No critical peaks detected</i>			-20 dBc		complies
2480		-2.36	30 dBm		Operating frequency
<i>No critical peaks detected</i>			-20 dBc		complies
Measurement uncertainty			± 3 dB		

Result: The measurement is passed.

Results:

TX spurious emissions conducted					
Pi/4-DQPSK - mode					
f [MHz]		amplitude of emission [dBm]	limit max. allowed emission power	actual attenuation below frequency of operation [dB]	results
2402		-6.88	30 dBm		Operating frequency
<i>No critical peaks detected</i>			-20 dBc		complies
2441		-5.05	30 dBm		Operating frequency
<i>No critical peaks detected</i>			-20 dBc		complies
2480		-4.73	30 dBm		Operating frequency
<i>No critical peaks detected</i>			-20 dBc		complies
Measurement uncertainty			± 3dB		

Result: The measurement is passed.

Results:

TX spurious emissions conducted					
8DPSK - mode					
f [MHz]		amplitude of emission [dBm]	limit max. allowed emission power	actual attenuation below frequency of operation [dB]	results
2402		-7.33	30 dBm		Operating frequency
<i>No critical peaks detected</i>			-20 dBc		complies
2441		-4.77	30 dBm		Operating frequency
<i>No critical peaks detected</i>			-20 dBc		complies
2480		-4.03	30 dBm		Operating frequency
<i>No critical peaks detected</i>			-20 dBc		complies
Measurement uncertainty		± 3dB			

Result: The measurement is passed.

Plots: GFSK

Plot 1: lowest channel – 2402 MHz, GFSK modulation, 0 Hz – 1 GHz

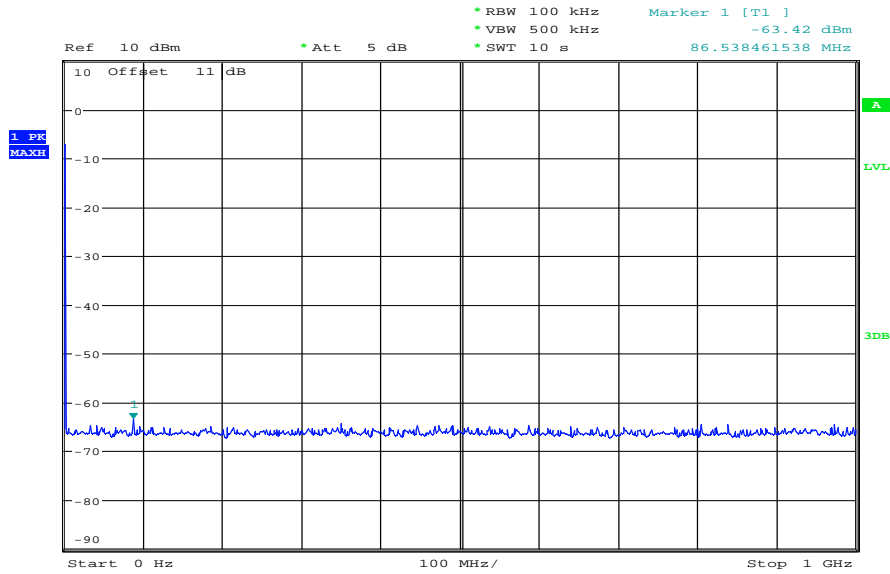

Date: 3.FEB.2012 10:22:04

Plot 2: lowest channel – 2402 MHz, GFSK modulation, 1 GHz – 12 GHz

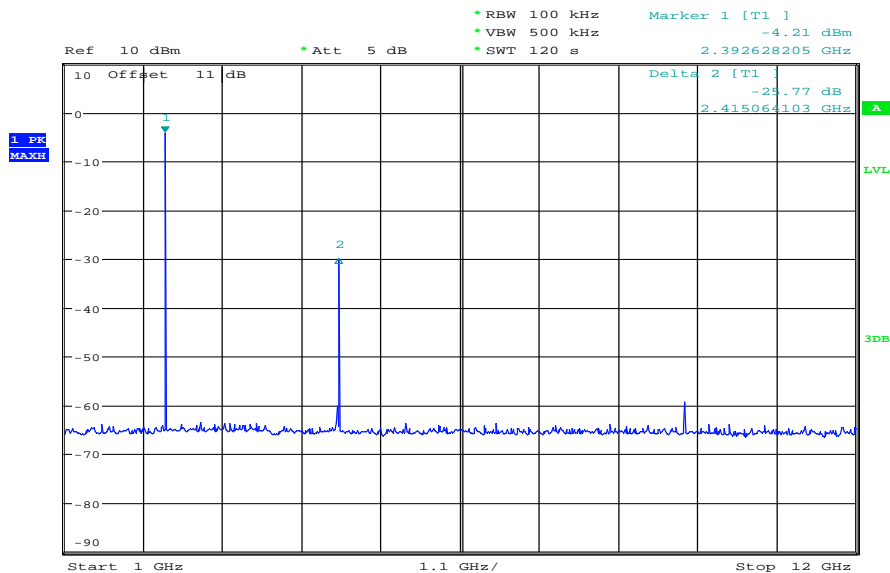

Date: 3.FEB.2012 10:26:01

Plot 3: lowest channel – 2402 MHz, GFSK modulation, 12 GHz – 25 GHz

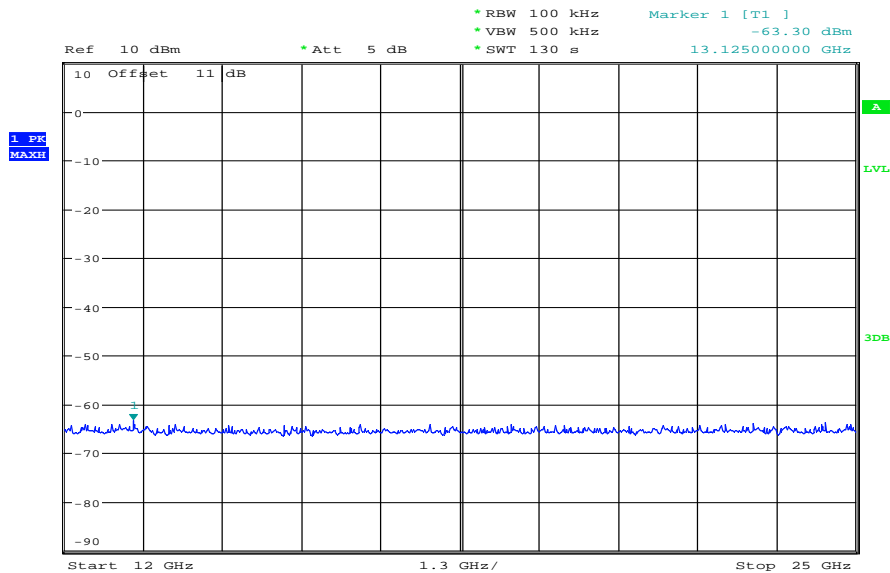

Date: 3.FEB.2012 10:28:41

Plot 4: middle channel – 2441 MHz, GFSK modulation, 0 Hz – 1 GHz

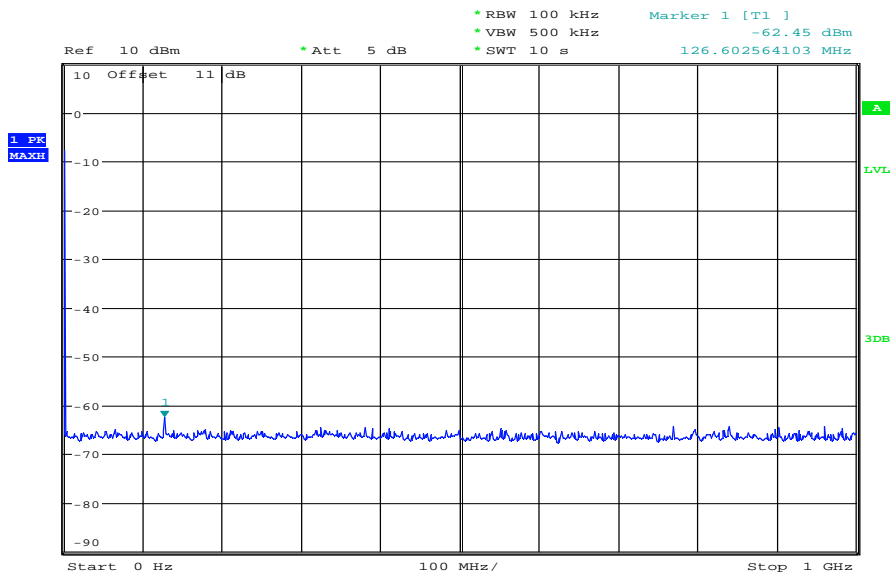

Date: 3.FEB.2012 10:44:03

Plot 5: middle channel – 2441 MHz, GFSK modulation, 1 GHz – 12 GHz

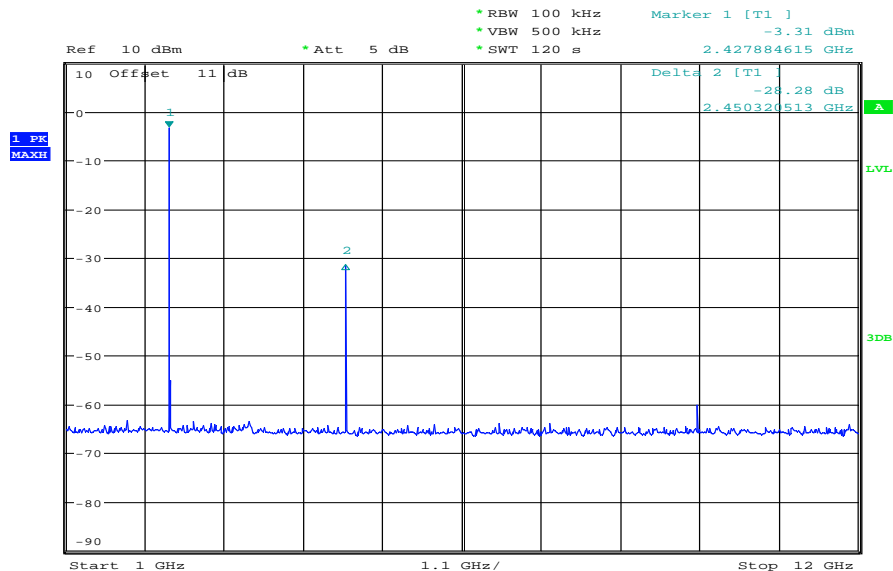

Date: 3.FEB.2012 10:43:23

Plot 6: middle channel – 2441 MHz, GFSK modulation, 12 GHz – 25 GHz

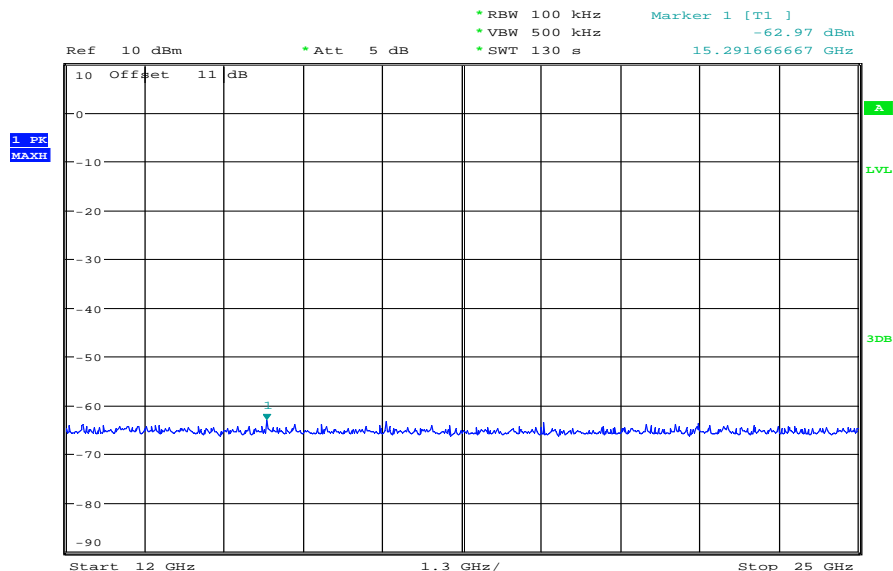

Date: 3.FEB.2012 10:32:40

Plot 7: highest channel – 2480 MHz, GFSK modulation, 0 Hz – 1 GHz

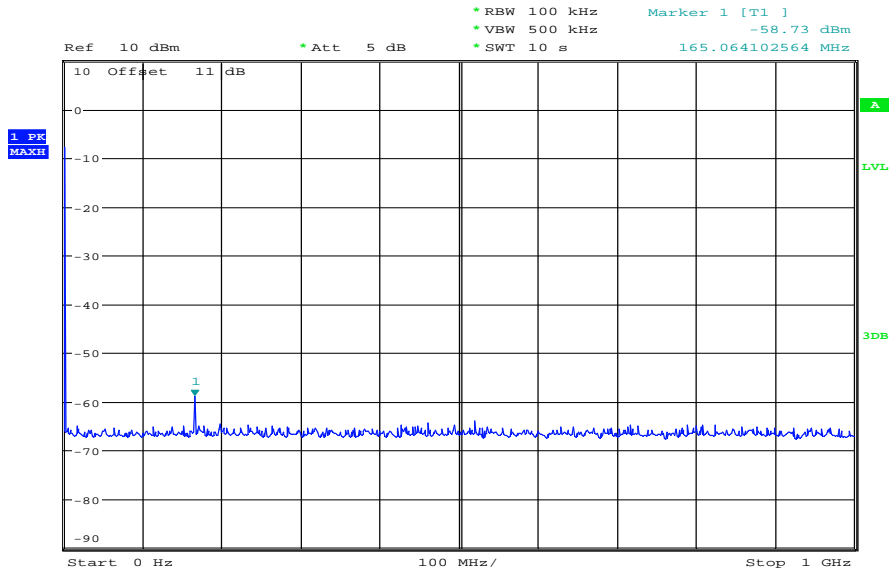

Date: 3.FEB.2012 10:44:52

Plot 8: highest channel – 2480 MHz, GFSK modulation, 1 GHz – 12 GHz

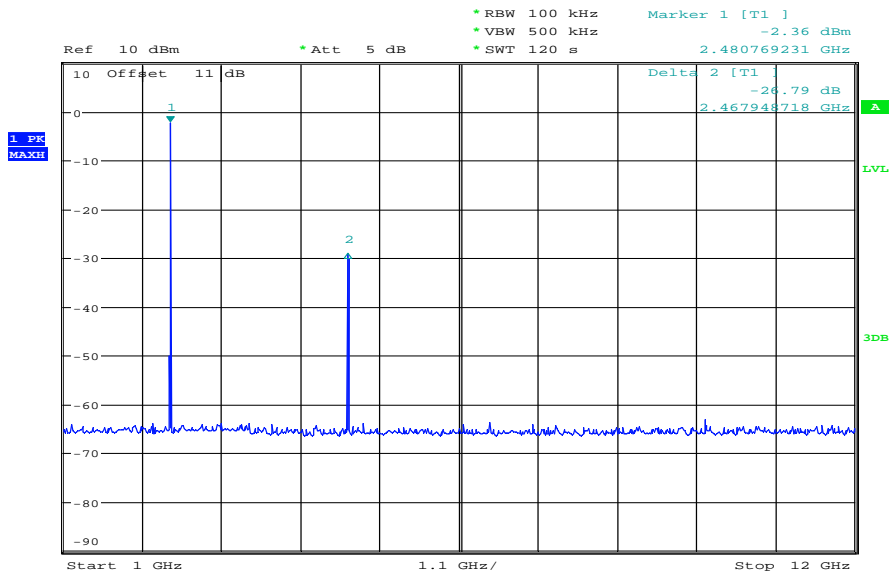

Date: 3.FEB.2012 10:47:19

Plot 9: highest channel – 2480 MHz, GFSK modulation, 12 GHz – 25 GHz

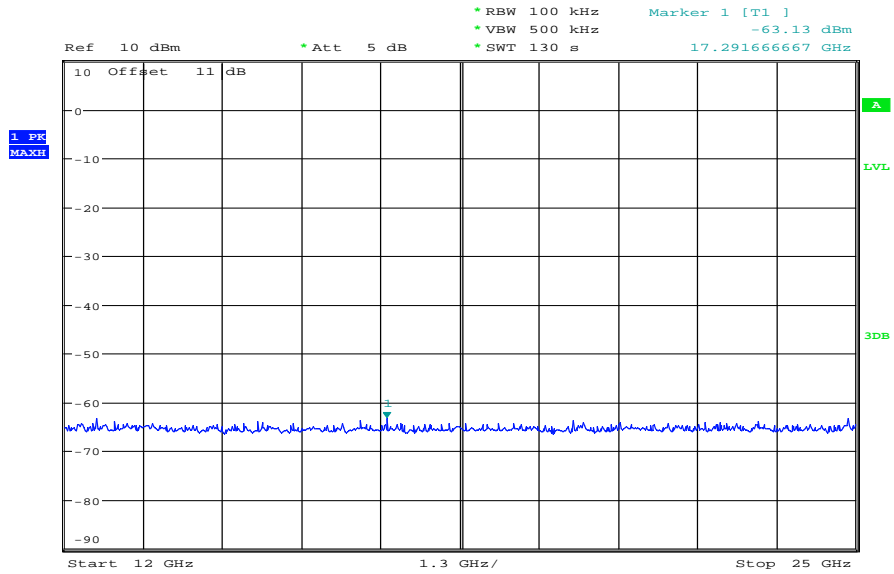

Date: 3.FEB.2012 10:50:05

Plots: Pi / DQPSK

Plot 1: lowest channel – 2402 MHz, Pi / DQPSK modulation, 0 Hz – 1 GHz

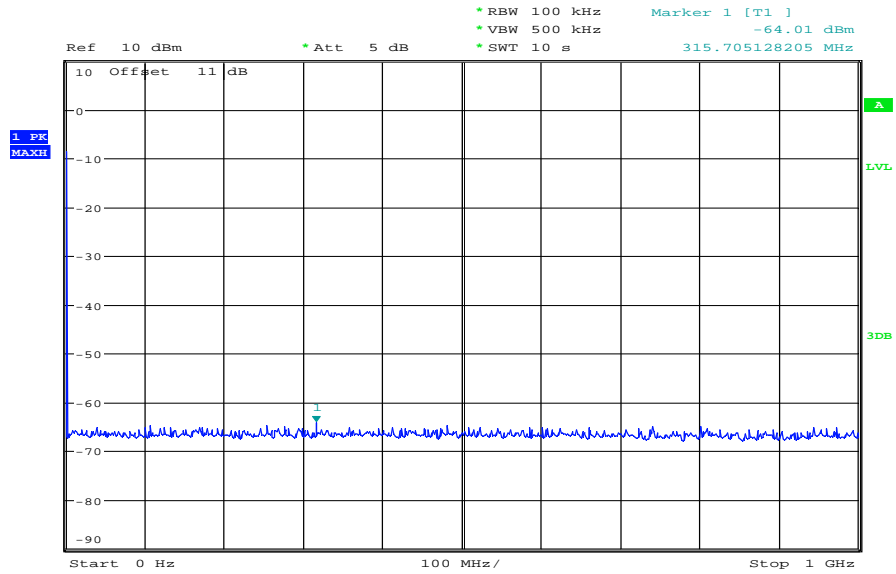

Date: 3.FEB.2012 11:08:53

Plot 2: lowest channel – 2402 MHz, Pi / DQPSK modulation, 1 GHz – 12 GHz

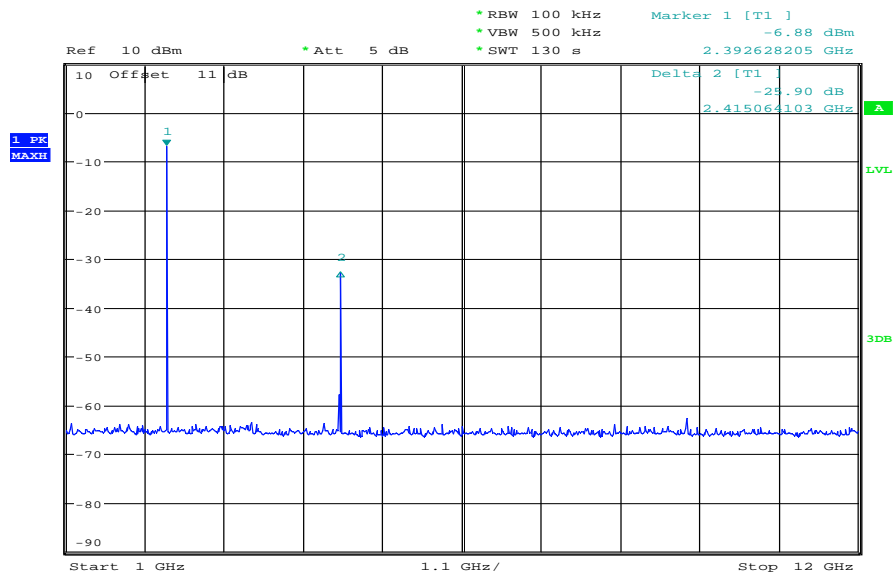

Date: 3.FEB.2012 11:08:20

Plot 3: lowest channel – 2402 MHz, Pi / DQPSK modulation, 12 GHz – 25 GHz

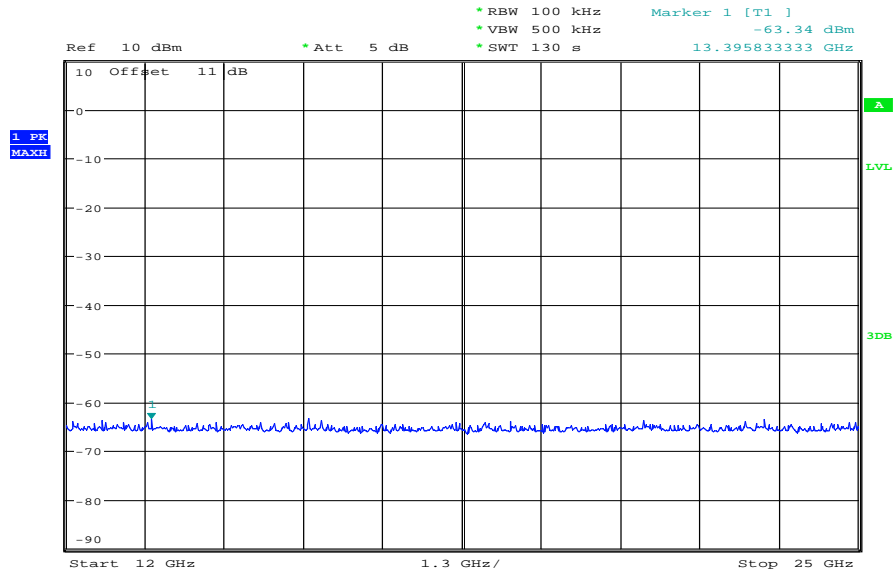

Date: 3.FEB.2012 11:05:45

Plot 4: middle channel – 2441 MHz, Pi / DQPSK modulation, 0 Hz – 1 GHz

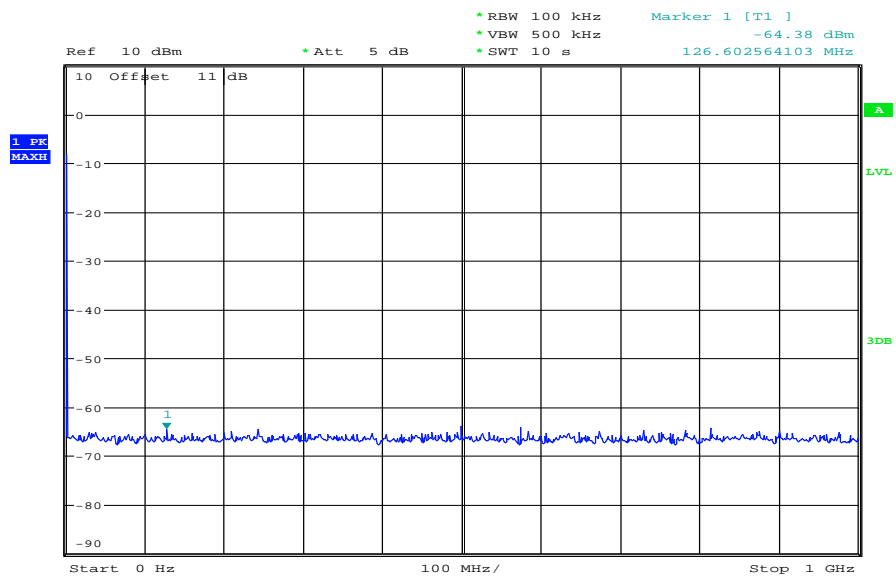

Date: 3.FEB.2012 10:56:51

Plot 5: middle channel – 2441 MHz, Pi / DQPSK modulation, 1 GHz – 12 GHz

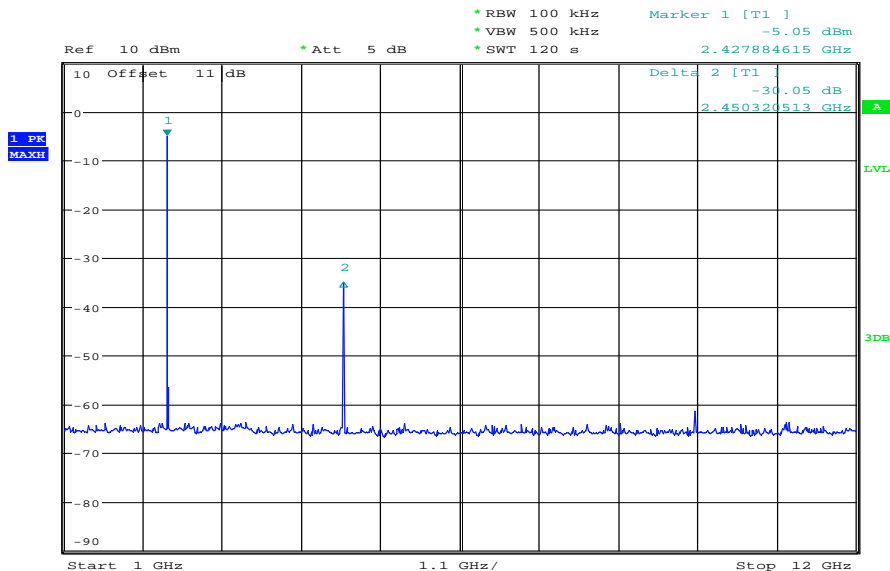

Date: 3.FEB.2012 10:59:26

Plot 6: middle channel – 2441 MHz, Pi / DQPSK modulation, 12 GHz – 25 GHz

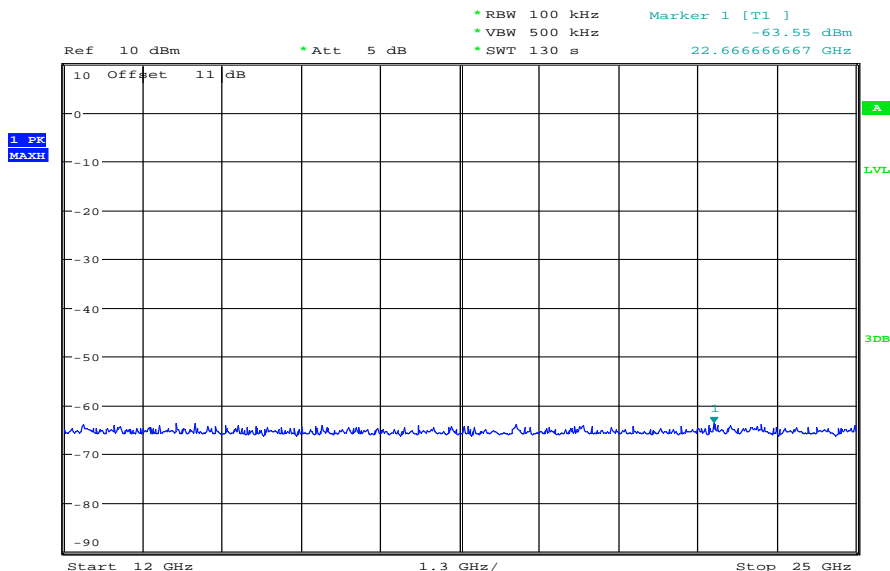

Date: 3.FEB.2012 11:02:17

Plot 7: highest channel – 2480 MHz, Pi / DQPSK modulation, 0 Hz – 1 GHz

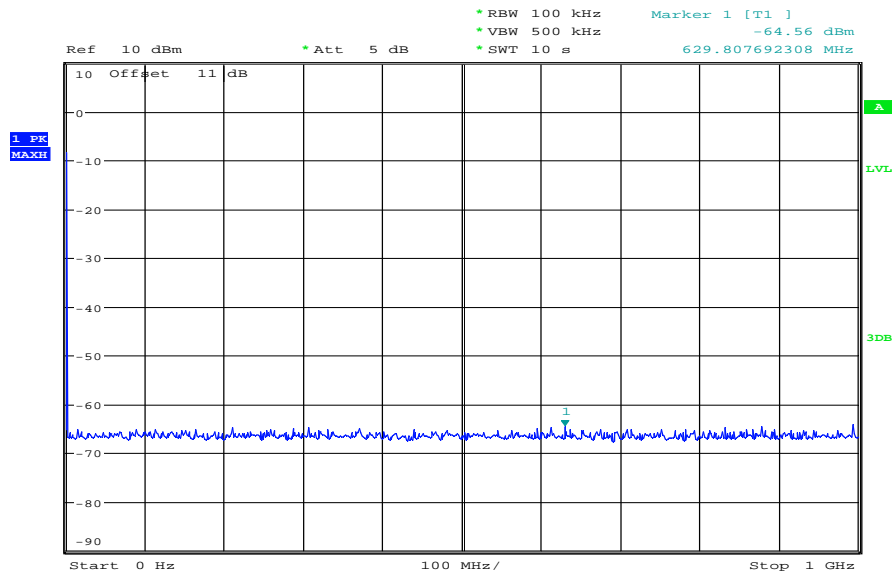

Date: 3.FEB.2012 10:56:04

Plot 8: highest channel – 2480 MHz, Pi / DQPSK modulation, 1 GHz – 12 GHz

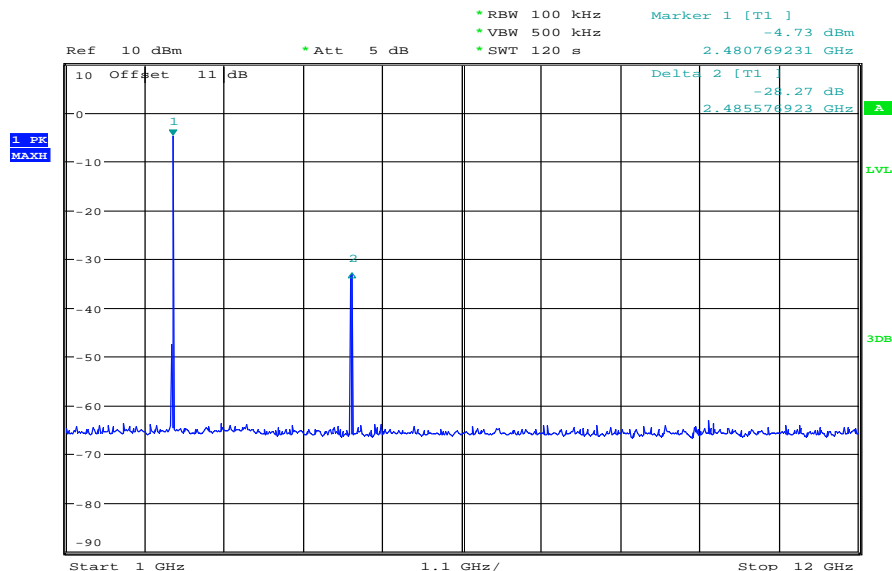

Date: 3.FEB.2012 10:55:22

Plot 9: highest channel – 2480 MHz, Pi / DQPSK modulation, 12 GHz – 25 GHz

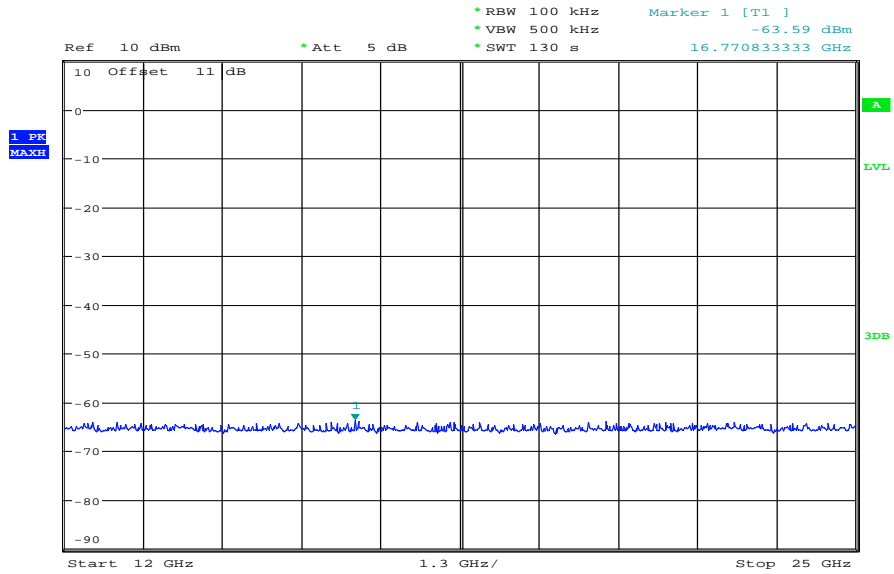

Date: 3.FEB.2012 10:52:57

Plots: 8 DPSK

Plot 1: lowest channel – 2402 MHz, 8 DPSK modulation, 0 Hz – 1 GHz

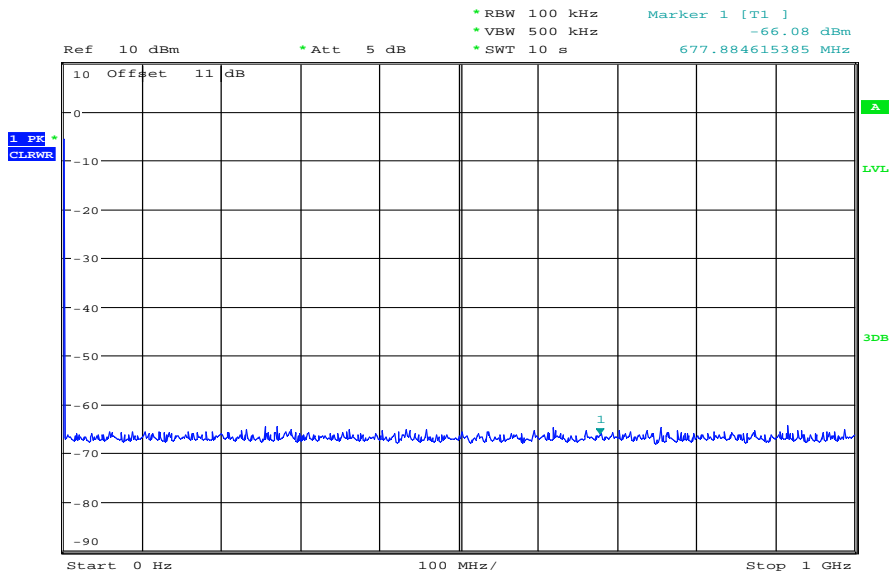

Date: 26.JAN.2012 08:14:03

Plot 2: lowest channel – 2402 MHz, 8 DPSK modulation, 1 GHz – 12 GHz

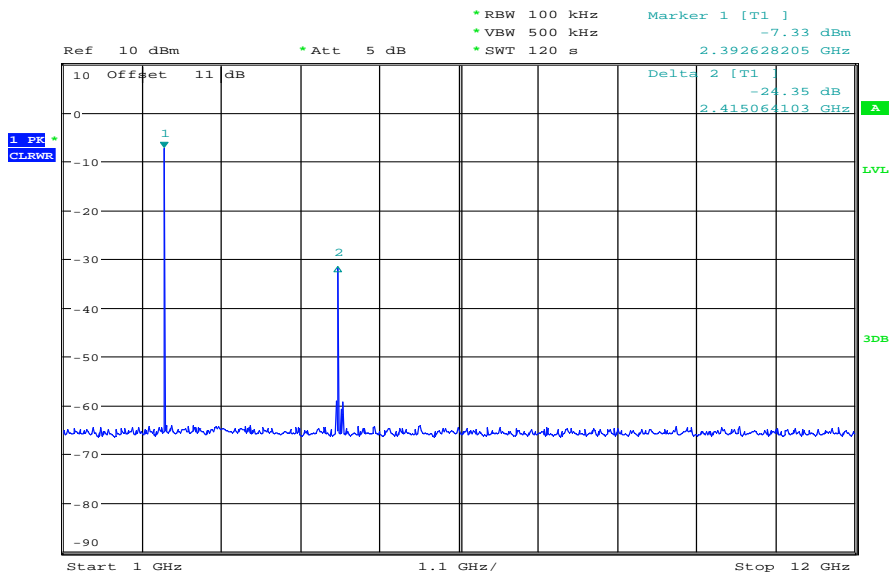

Date: 26.JAN.2012 08:16:44

Plot 3: lowest channel – 2402 MHz, 8 DPSK modulation, 12 GHz – 25 GHz

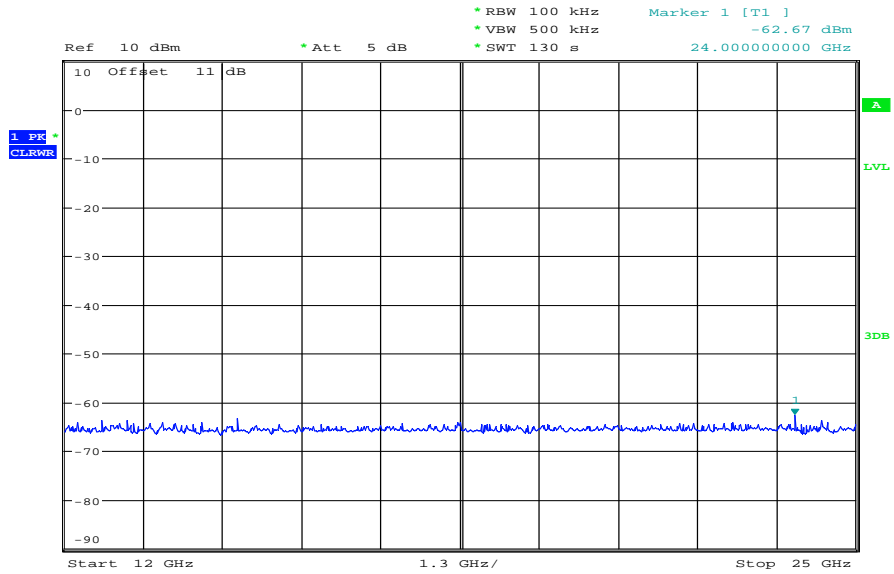

Date: 26.JAN.2012 08:19:35

Plot 4: middle channel – 2441 MHz, 8 DPSK modulation, 0 Hz – 1 GHz

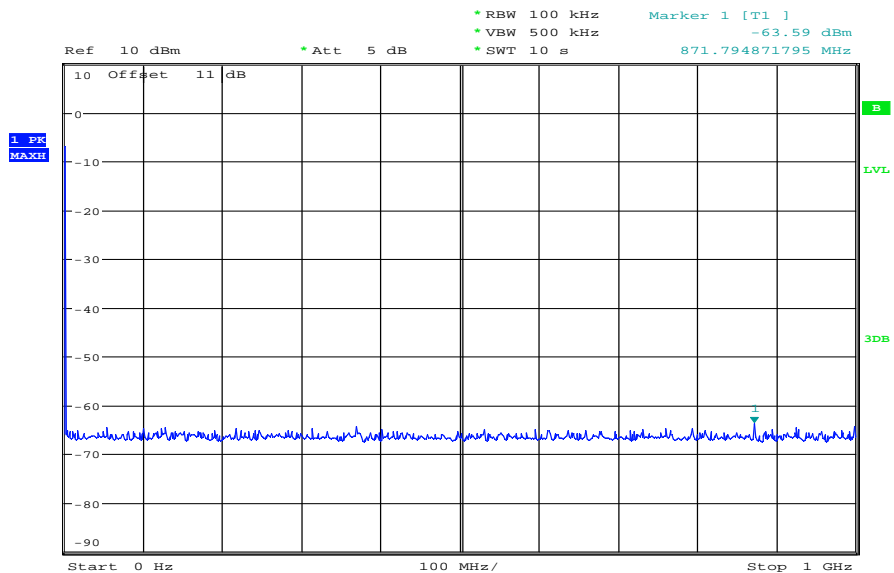

Date: 26.JAN.2012 09:11:51

Plot 5: middle channel – 2441 MHz, 8 DPSK modulation, 1 GHz – 12 GHz

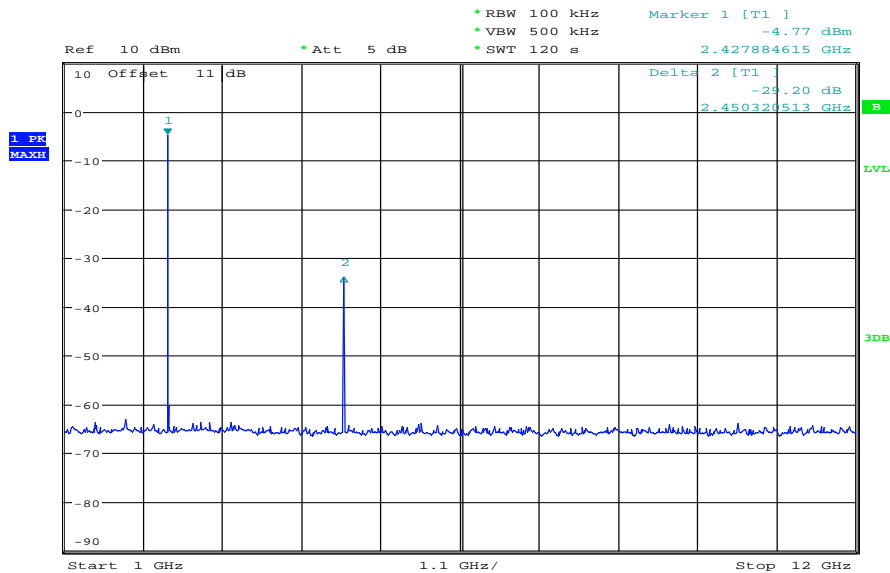

Date: 26.JAN.2012 09:11:10

Plot 6: middle channel – 2441 MHz, 8 DPSK modulation, 12 GHz – 25 GHz

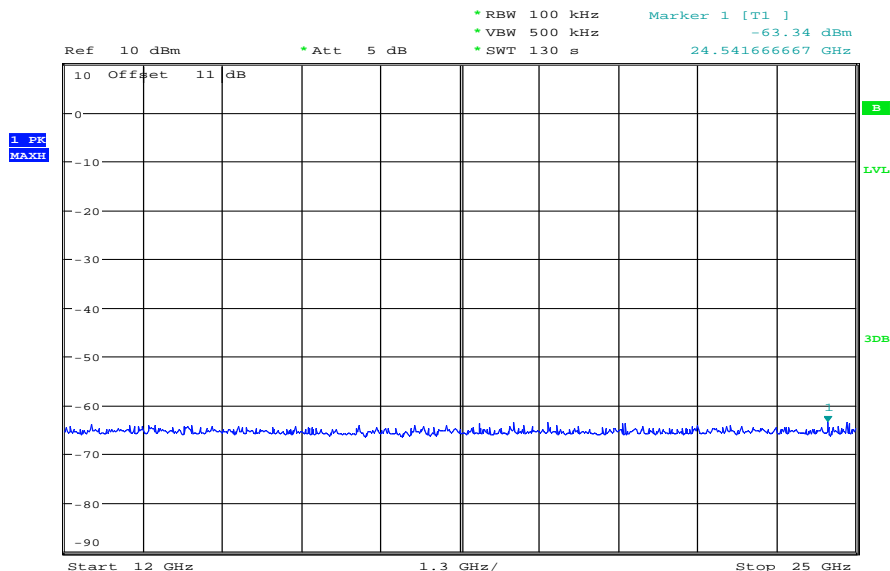

Date: 26.JAN.2012 09:08:41

Plot 7: highest channel – 2480 MHz, 8 DPSK modulation, 0 Hz – 1 GHz

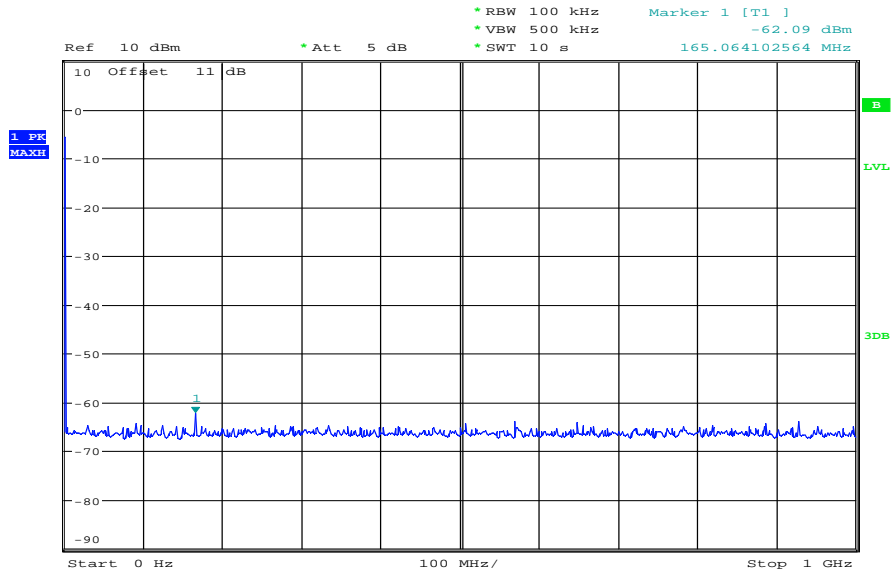

Date: 26.JAN.2012 08:54:46

Plot 8: highest channel – 2480 MHz, 8 DPSK modulation, 1 GHz – 12 GHz

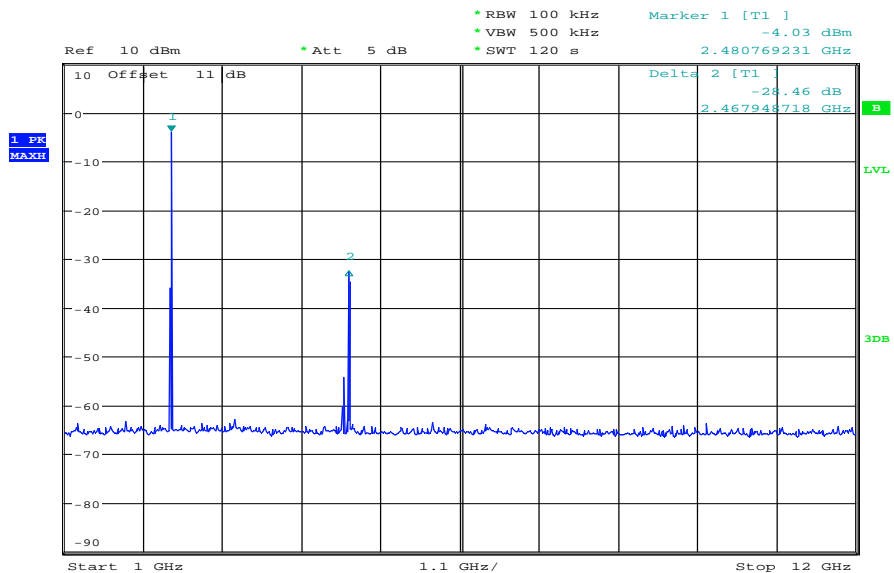

Date: 26.JAN.2012 08:58:17

Plot 9: highest channel – 2480 MHz, 8 DPSK modulation, 12 GHz – 25 GHz

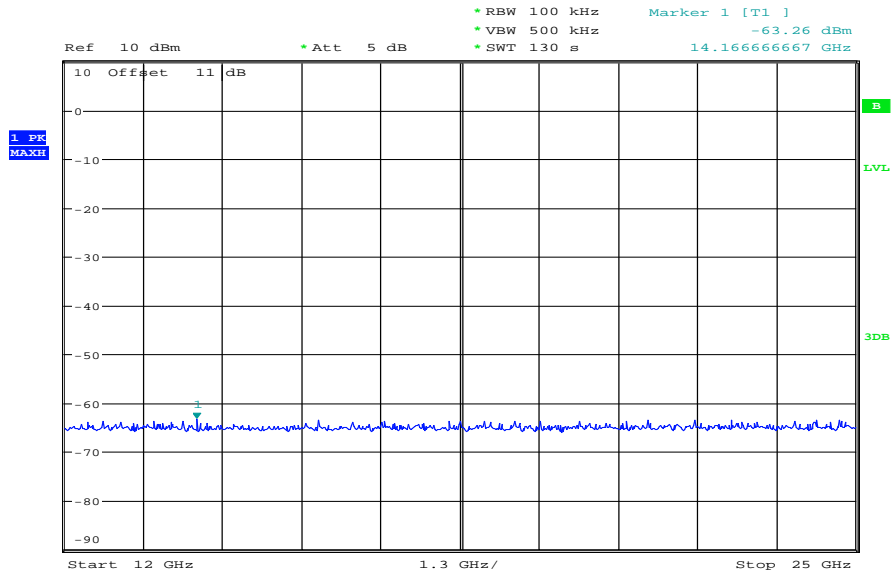

Date: 26.JAN.2012 09:05:34

9.11 TX spurious emissions radiated

Description:

Measurement of the radiated spurious emissions in transmit mode. The EUT is set to single channel mode and the transmit channel is channel 00, channel 39 and channel 78. The measurement is performed in the mode with the highest output power.

Measurement:

Measurement parameter	
Detector:	Peak / Quasi Peak
Sweep time:	Auto
Video bandwidth:	Sweep: 100 kHz Remeasurement: 10 Hz
Resolution bandwidth:	F < 1 GHz: 100 kHz F > 1 GHz: 1 MHz
Span:	30 MHz to 25 GHz
Trace-Mode:	Max Hold
Measured Modulation:	<input checked="" type="checkbox"/> GFSK <input type="checkbox"/> Pi/4 DQPSK <input type="checkbox"/> 8DPSK

The modulation with the highest output power was used to perform the transmitter spurious emissions. If spurious were detected a re-measurement was performed on the detected frequency with each modulation.

Limits:

FCC		IC	
CFR Part 15.247(d)		RSS 210, Issue 8, A 8.5	
TX spurious emissions radiated			
<p>In any 100 kHz bandwidth outside the frequency band in which the spread spectrum or digitally modulated intentional radiator is operating, the radio frequency power that is produced by the intentional radiator shall be at least 20 dB below that in the 100 kHz bandwidth within the band that contains the highest level of the desired power, based on either an RF conducted or a radiated measurement. Attenuation below the general limits specified in Section 15.209(a) is not required. In addition, radiated emissions which fall in the restricted bands, as defined in §15.205(a), must also comply with the radiated emission limits specified in §15.209(a) (see §15.205(c)).</p>			
§15.209			
Frequency (MHz)	Field strength (dBµV/m)	Measurement distance	
30 - 88	30.0	10	
88 – 216	33.5	10	
216 – 960	36.0	10	
Above 960	54.0	3	

Results: Also see plots

TX spurious emissions radiated [dBµV/m]								
2402 MHz			2441 MHz			2480 MHz		
F [MHz]	Detector	Level [dBµV/m]	F [MHz]	Detector	Level [dBµV/m]	F [MHz]	Detector	Level [dBµV/m]
For emissions below 10 GHz, please take a look at the table below the plots.			For emissions below 10 GHz, please take a look at the table below the plots.			For emissions below 10 GHz, please take a look at the table below the plots.		
For emissions above 10 GHz, please take a look at the plots.			For emissions above 10 GHz, please take a look at the plots.			For emissions above 10 GHz, please take a look at the plots.		
Measurement uncertainty			± 3 dB					

Result: The measurement is passed.

Plots:

Plot 1: TX mode, lowest channel, 30 MHz to 1 GHz, vertical & horizontal polarization

Common Information

EUT: T640
 Serial Number: 55800032
 Test Description: FCC 15
 Operating Conditions: BT testmode, channel 0, charging
 Operator Name: Kraus
 Comment: Power 115V/60Hz

Scan Setup: STAN_Fin [EMI radiated]

Hardware Setup: Electric Field (NOS)
 Level Unit: dBµV/m

Subrange **Detectors** **IF Bandwidth** **Meas. Time** **Receiver**
 30 MHz - 2 GHz QuasiPeak 120 kHz 15 s Receiver

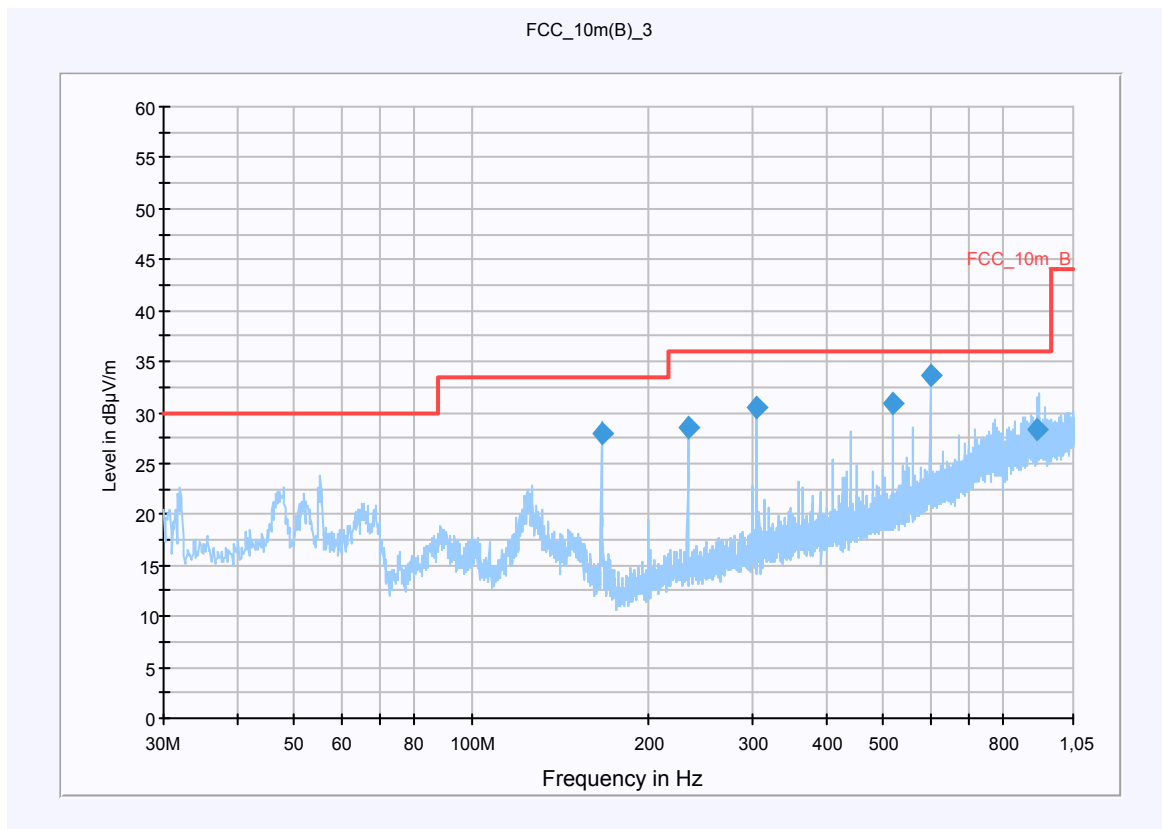

Final Result 1

Frequency (MHz)	QuasiPeak (dBµV/m)	Meas. Time (ms)	Bandwidth (kHz)	Antenna height (cm)	Polarity	Turntable position (deg)	Corr. (dB)	Margin (dB)	Limit (dBµV/m)	Comment
166.228050	27.9	15000.000	120.000	98.0	V	106.0	9.6	5.6	33.5	
232.729950	28.6	15000.000	120.000	115.0	V	179.0	12.8	7.4	36.0	
304.766700	30.5	15000.000	120.000	350.0	H	178.0	14.7	5.5	36.0	
519.982800	30.8	15000.000	120.000	350.0	V	168.0	19.0	5.2	36.0	
599.983800	33.7	15000.000	120.000	148.0	H	283.0	20.8	2.3	36.0	
914.253600	28.2	15000.000	120.000	319.0	H	283.0	25.2	7.8	36.0	

Hardware Setup: EMI radiated\Electric Field (NOS) - [EMI radiated]

Subrange 1

Frequency Range:	30 MHz - 2 GHz
Receiver:	Receiver [ESCI 3] @ GPIB0 (ADR 20), SN 100083/003, FW 4.42
Signal Path:	without Notch FW 1.0
Antenna:	VULB 9163 SN 9163-295, FW --- Correction Table (vertical): VULP6113 Correction Table (horizontal): VULP6113 Correction Table: Cable_EN_1GHz (1005)
Antenna Tower:	Tower [EMCO 2090 Antenna Tower] @ GPIB0 (ADR 8), FW REV 3.12
Turntable:	Turntable [EMCO Turntable] @ GPIB0 (ADR 9), FW REV 3.12

EMC 32 Version 8.10.00

Plot 2: TX mode, lowest channel, 1 GHz to 10 GHz, vertical & horizontal polarization

Common Information

EUT:	T640
Serial Number:	55800032
Test Description:	FCC 15
Operating Conditions:	BT testmode, channel 0, charging
Operator Name:	Kraus
Comment:	Power 115V/60Hz

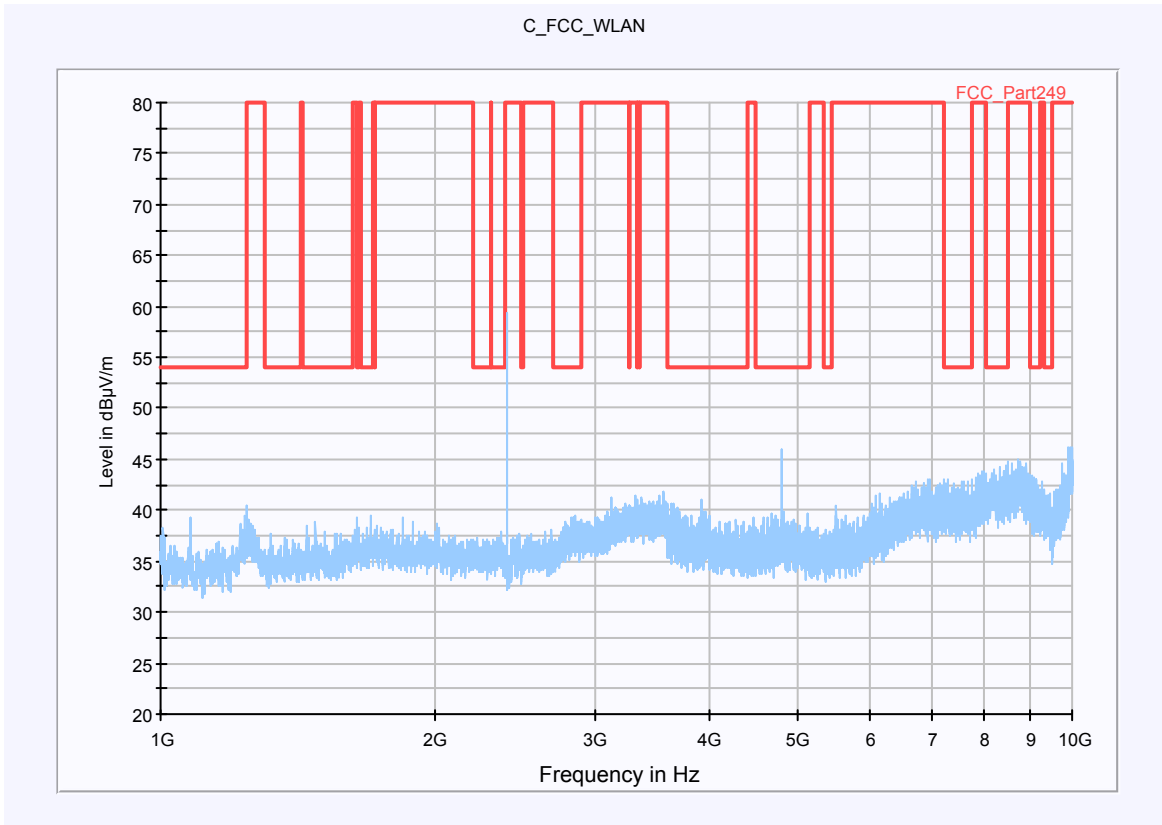

The carrier signal is slightly suppressed with a 2.4 GHz band rejection filter.

Hardware Setup: EMI radiated\C_MATRIX - [EMI radiated]

Subrange 1

Frequency Range: 1 GHz - 4 GHz

Receiver: ESU [ESU 26]
@ GPIB0 (ADR 17), SN 100037/026, FW 4.43

Signal Path: EN_NOTCH
FW 1.0
Correction Table: LNA_EN (Notch)
Correction Table: 3_5m

Antenna: BBHA 9120 B
Correction Table (vertical): BBHA9120
Correction Table (horizontal): BBHA9120
Correction Table: Cable_Horn_EN (1103)

Antenna Tower: Generic Tripod [Generic Tripod]
@ GPIB0 (ADR 19), SN ?

Turntable: Turntable [EMCO Turntable]
@ GPIB0 (ADR 9), FW REV 3.12

Subrange 2

Frequency Range: 4 GHz - 10 GHz

Receiver: ESU [ESU 26]
@ GPIB0 (ADR 17), SN 100037/026, FW 4.43

Signal Path: EN_HP
Correction Table: 3_5m
Correction Table: LNA_EN (HP)

Antenna: BBHA 9120 B
Correction Table (vertical): BBHA9120
Correction Table (horizontal): BBHA9120
Correction Table: Cable_Horn_EN (1103)

Antenna Tower: Generic Tripod [Generic Tripod]
@ GPIB0 (ADR 19), SN ?

Turntable: Turntable [EMCO Turntable]
@ GPIB0 (ADR 9), FW REV 3.12

Plot 3: TX mode, lowest channel, 10 GHz to 18 GHz, vertical & horizontal polarization

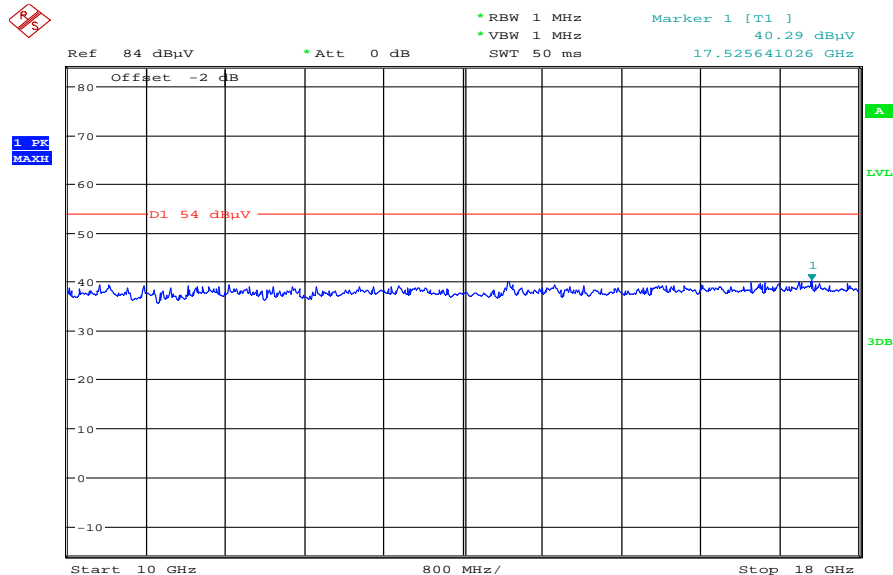

Date: 20.APR.2011 18:23:28

Plot 4: TX mode, lowest channel, 18 GHz to 25 GHz, vertical & horizontal polarization

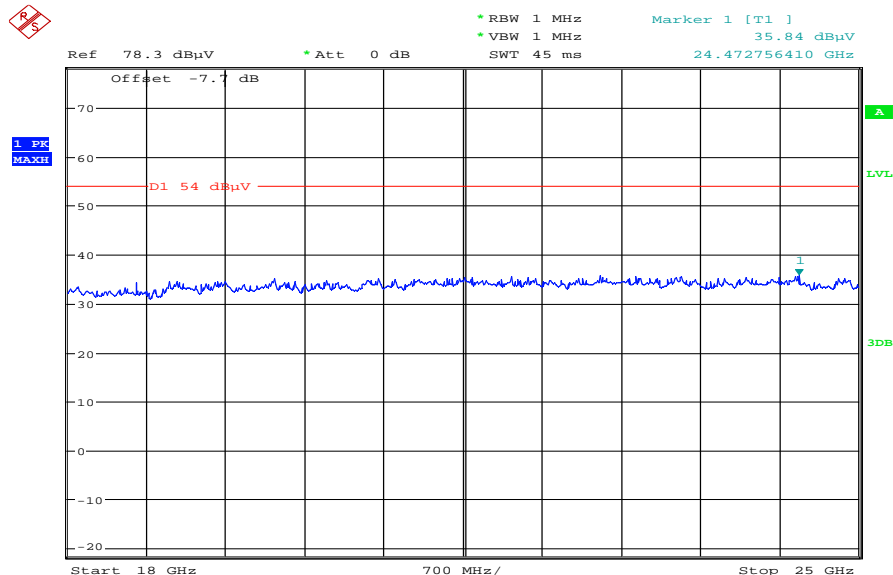

Date: 20.APR.2011 18:11:28

Plot 5: TX mode, middle channel, 30 MHz to 1 GHz, vertical & horizontal polarization

Common Information

EUT: T640
 Serial Number: 55800032
 Test Description: FCC 15
 Operating Conditions: BT testmode, channel 39, charging
 Operator Name: Kraus
 Comment: Power 115 V / 60 Hz

Scan Setup: STAN_Fin [EMI radiated]

Hardware Setup: Electric Field (NOS)
 Level Unit: dBµV/m

Subrange **Detectors** **IF Bandwidth** **Meas. Time** **Receiver**
 30 MHz - 2 GHz QuasiPeak 120 kHz 15 s Receiver

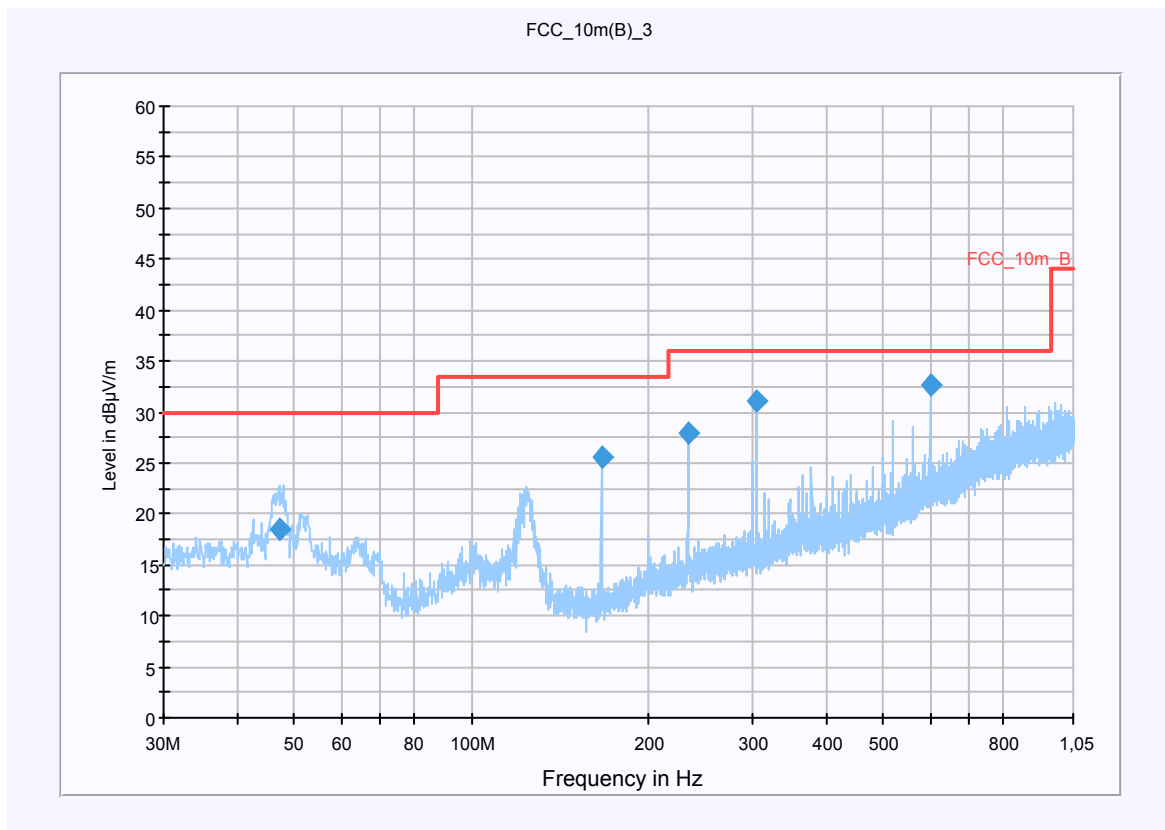

Final Result 1

Frequency (MHz)	QuasiPeak (dBµV/m)	Meas. Time (ms)	Bandwidth (kHz)	Antenna height (cm)	Polarity	Turntable position (deg)	Corr. (dB)	Margin (dB)	Limit (dBµV/m)	Comment
47.307300	18.4	15000.000	120.000	106.0	V	196.0	13.3	11.6	30.0	
166.239750	25.5	15000.000	120.000	106.0	V	83.0	9.6	8.0	33.5	
232.735500	28.0	15000.000	120.000	98.0	V	182.0	12.8	8.0	36.0	
304.759800	31.0	15000.000	120.000	98.0	V	0.0	14.7	5.0	36.0	
600.006750	32.7	15000.000	120.000	148.0	H	283.0	20.8	3.3	36.0	

Hardware Setup: EMI radiated\Electric Field (NOS) - [EMI radiated]

Subrange 1

Frequency Range:	30 MHz - 2 GHz
Receiver:	Receiver [ESCI 3] @ GPIB0 (ADR 20), SN 100083/003, FW 4.42
Signal Path:	without Notch FW 1.0
Antenna:	VULB 9163 SN 9163-295, FW --- Correction Table (vertical): VULP6113 Correction Table (horizontal): VULP6113 Correction Table: Cable_EN_1GHz (1005)
Antenna Tower:	Tower [EMCO 2090 Antenna Tower] @ GPIB0 (ADR 8), FW REV 3.12
Turntable:	Turntable [EMCO Turntable] @ GPIB0 (ADR 9), FW REV 3.12

EMC 32 Version 8.10.00

Plot 6: TX mode, middle channel, 1 GHz to 10 GHz, vertical & horizontal polarization

Common Information

EUT: T640
 Serial Number: 55800032
 Test Description: FCC 15
 Operating Conditions: BT testmode, channel 39, charging
 Operator Name: Kraus
 Comment: Power 115 V / 60 Hz

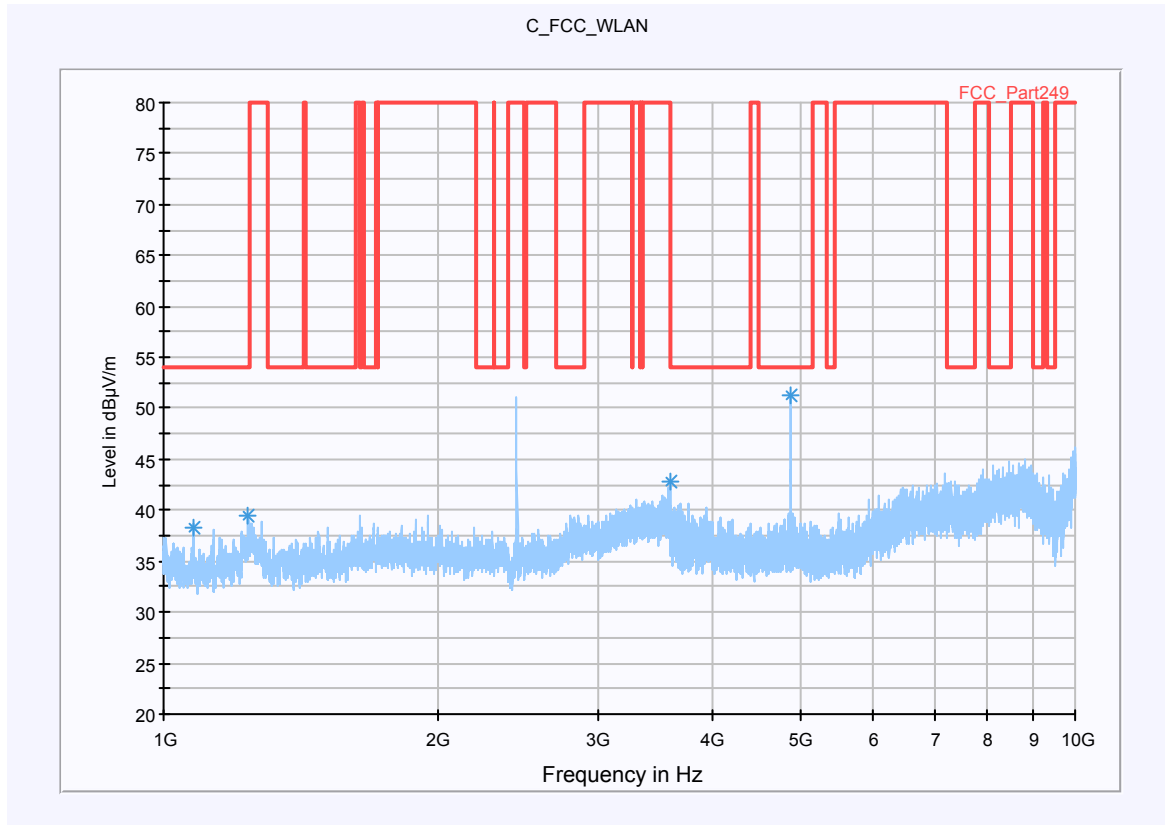

The carrier signal is slightly suppressed with a 2.4 GHz band rejection filter.

Data Reduction 1 [1]

Frequency (MHz)	MaxPeak-MaxHold (dBµV/m)	Antenna height (cm)	Polarity	Turntable position (deg)	Corr. (dB)	Comment
4883.800000	51.2	100.0	V	182.0	1.0	
3598.900000	42.9	100.0	H	268.0	0.6	
1239.700000	39.4	100.0	V	92.0	-1.9	
1080.100000	38.2	100.0	V	182.0	-4.7	

Hardware Setup: EMI radiated\C_MATRIX - [EMI radiated]

Subrange 1

Frequency Range: 1 GHz - 4 GHz

Receiver: ESU [ESU 26]
@ GPIB0 (ADR 17), SN 100037/026, FW 4.43

Signal Path: EN_NOTCH
FW 1.0
Correction Table: LNA_EN (Notch)
Correction Table: 3_5m

Antenna: BBHA 9120 B
Correction Table (vertical): BBHA9120
Correction Table (horizontal): BBHA9120
Correction Table: Cable_Horn_EN (1103)

Antenna Tower: Generic Tripod [Generic Tripod]
@ GPIB0 (ADR 19), SN ?

Turntable: Turntable [EMCO Turntable]
@ GPIB0 (ADR 9), FW REV 3.12

Subrange 2

Frequency Range: 4 GHz - 10 GHz

Receiver: ESU [ESU 26]
@ GPIB0 (ADR 17), SN 100037/026, FW 4.43

Signal Path: EN_HP
Correction Table: 3_5m
Correction Table: LNA_EN (HP)

Antenna: BBHA 9120 B
Correction Table (vertical): BBHA9120
Correction Table (horizontal): BBHA9120
Correction Table: Cable_Horn_EN (1103)

Antenna Tower: Generic Tripod [Generic Tripod]
@ GPIB0 (ADR 19), SN ?

Turntable: Turntable [EMCO Turntable]
@ GPIB0 (ADR 9), FW REV 3.12

Plot 7: TX mode, middle channel, 10 GHz to 18 GHz, vertical & horizontal polarization

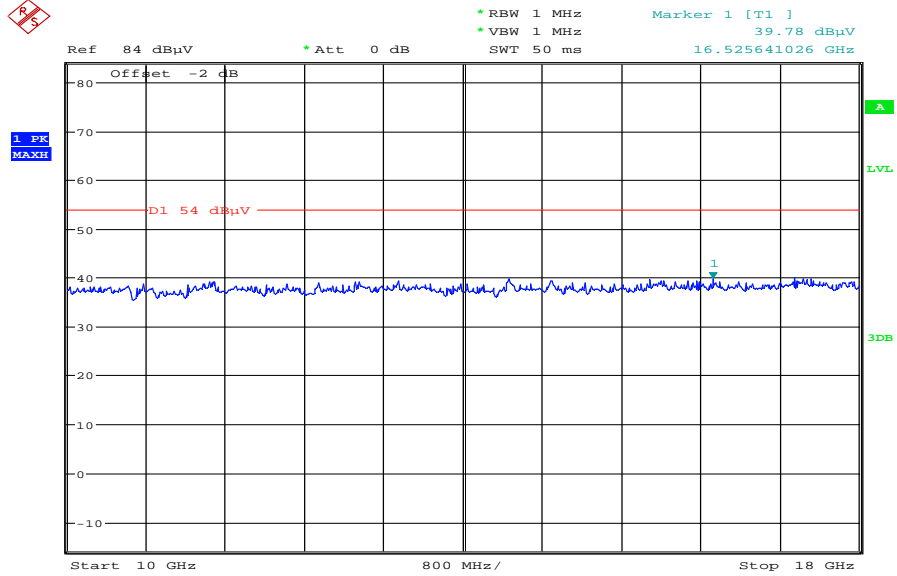

Date: 20.APR.2011 18:21:33

Plot 8: TX mode, middle channel, 18 GHz to 25 GHz, vertical & horizontal polarization

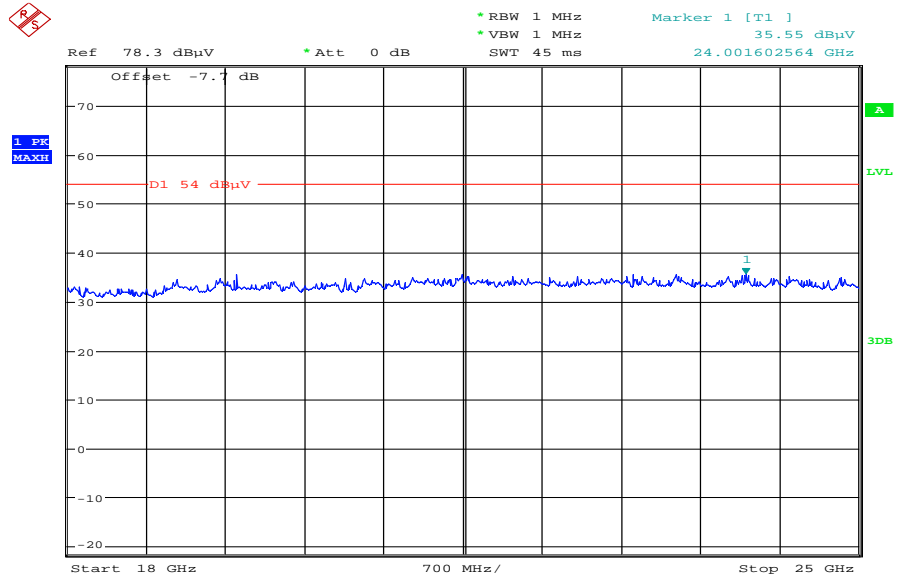

Date: 20.APR.2011 18:13:26

Plot 9: TX mode, highest channel, 30 MHz to 1 GHz, vertical & horizontal polarization

Common Information

EUT: T640
 Serial Number: 55800032
 Test Description: FCC 15
 Operating Conditions: BT testmode, channel 78, charging
 Operator Name: Hennemann
 Comment: Power 115 V / 60 Hz

Scan Setup: STAN_Fin [EMI radiated]

Hardware Setup: Electric Field (NOS)
 Level Unit: dBµV/m

Subrange	Detectors	IF Bandwidth	Meas. Time	Receiver
30 MHz - 2 GHz	QuasiPeak	120 kHz	15 s	Receiver

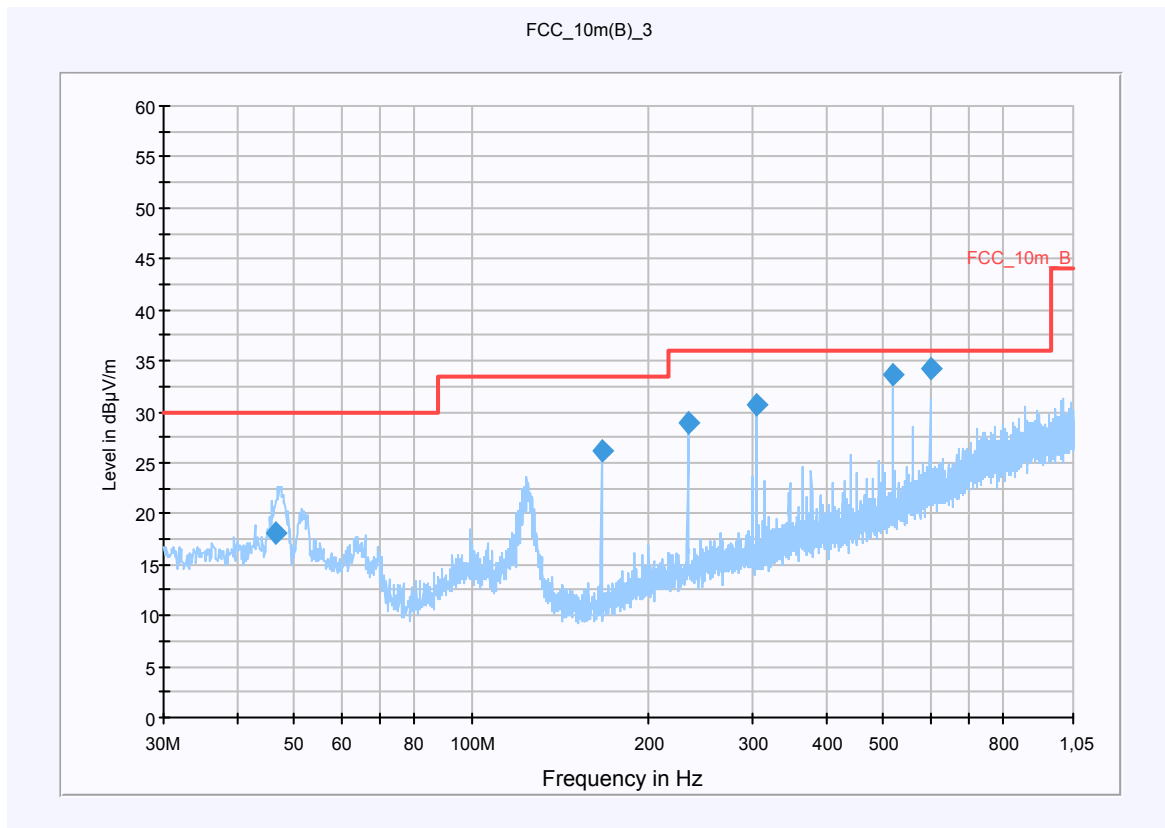

Final Result 1

Frequency (MHz)	QuasiPeak (dBµV/m)	Meas. Time (ms)	Bandwidth (kHz)	Antenna height (cm)	Polarity	Turntable position (deg)	Corr. (dB)	Margin (dB)	Limit (dBµV/m)	Comment
46.687350	18.2	15000.000	120.000	98.0	V	196.0	13.3	11.8	30.0	
166.232700	26.1	15000.000	120.000	98.0	V	83.0	9.6	7.4	33.5	
232.739850	29.0	15000.000	120.000	98.0	V	196.0	12.8	7.0	36.0	
304.758450	30.8	15000.000	120.000	98.0	V	83.0	14.7	5.2	36.0	
520.001700	33.6	15000.000	120.000	148.0	H	83.0	19.0	2.4	36.0	
599.982600	34.1	15000.000	120.000	148.0	H	283.0	20.8	1.9	36.0	

Hardware Setup: EMI radiated\Electric Field (NOS) - [EMI radiated]

Subrange 1

Frequency Range: 30 MHz - 2 GHz

Receiver: Receiver [ESCI 3]
@ GPIB0 (ADR 20), SN 100083/003, FW 4.42

Signal Path: without Notch
FW 1.0

Antenna: VULB 9163
SN 9163-295, FW ---
Correction Table (vertical): VULP6113
Correction Table (horizontal): VULP6113
Correction Table: Cable_EN_1GHz (1005)

Antenna Tower: Tower [EMCO 2090 Antenna Tower]
@ GPIB0 (ADR 8), FW REV 3.12

Turntable: Turntable [EMCO Turntable]
@ GPIB0 (ADR 9), FW REV 3.12

EMC 32 Version 8.10.00

Plot 10: TX mode, highest channel, 1 GHz to 10 GHz, vertical & horizontal polarization

Common Information

EUT: T640
 Serial Number: 55800032
 Test Description: FCC 15
 Operating Conditions: BT testmode, channel 78, charging
 Operator Name: Hennemann
 Comment: Power 115 V / 60 Hz

Scan Setup: C_FIN [EMI radiated]

Hardware Setup: C_MATRIX
 Level Unit: dBµV/m

Subrange	Detectors	IF Bandwidth	Meas. Time	Receiver
1 GHz - 4 GHz	Average	1 MHz	0,1 s	ESU
4 GHz - 10 GHz	Average	1 MHz	0,1 s	ESU

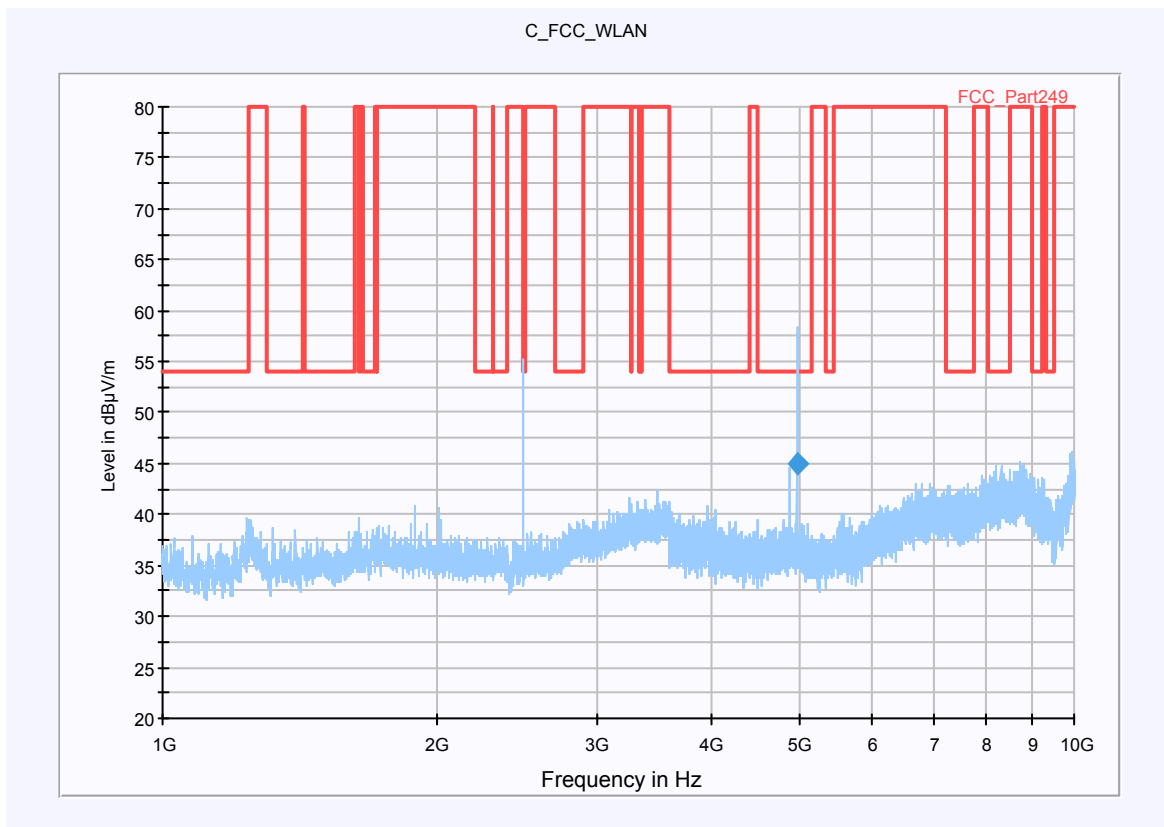

The carrier signal is slightly suppressed with a 2.4 GHz band rejection filter.

Copy of Frequency List 1_2

Frequency (MHz)	MaxPeak-ClearWrite (dBµV/m)	MaxPeak-MaxHold (dBµV/m)	Antenna height (cm)	Polarity	Turntable position (deg)	Corr. (dB)	Comment
4963.616000	---	59.2	100.0	H	90.0	1.3	D1

Final Result 1

Frequency (MHz)	Average (dBµV/m)	Meas. Time (ms)	Bandwidth (kHz)	Antenna height (cm)	Polarity	Turntable position (deg)	Corr. (dB)	Margin (dB)	Limit (dBµV/m)	Comment
4963.616000	45.0	100.000	1000.000	100.0	H	87.0	1.3	9.0	54.0	

Hardware Setup: EMI radiated\C_MATRIX - [EMI radiated]

Subrange 1

Frequency Range: 1 GHz - 4 GHz

Receiver: ESU [ESU 26]
@ GPIB0 (ADR 17), SN 100037/026, FW 4.43

Signal Path: EN_NOTCH
FW 1.0
Correction Table: LNA_EN (Notch)
Correction Table: 3_5m

Antenna: BBHA 9120 B
Correction Table (vertical): BBHA9120
Correction Table (horizontal): BBHA9120
Correction Table: Cable_Horn_EN (1103)

Antenna Tower: Generic Tripod [Generic Tripod]
@ GPIB0 (ADR 19), SN ?

Turntable: Turntable [EMCO Turntable]
@ GPIB0 (ADR 9), FW REV 3.12

Subrange 2

Frequency Range: 4 GHz - 10 GHz

Receiver: ESU [ESU 26]
@ GPIB0 (ADR 17), SN 100037/026, FW 4.43

Signal Path: EN_HP
Correction Table: 3_5m
Correction Table: LNA_EN (HP)

Antenna: BBHA 9120 B
Correction Table (vertical): BBHA9120
Correction Table (horizontal): BBHA9120
Correction Table: Cable_Horn_EN (1103)

Antenna Tower: Generic Tripod [Generic Tripod]
@ GPIB0 (ADR 19), SN ?

Turntable: Turntable [EMCO Turntable]
@ GPIB0 (ADR 9), FW REV 3.12

Plot 11: TX mode, highest channel, 10 GHz to 18 GHz, vertical & horizontal polarization

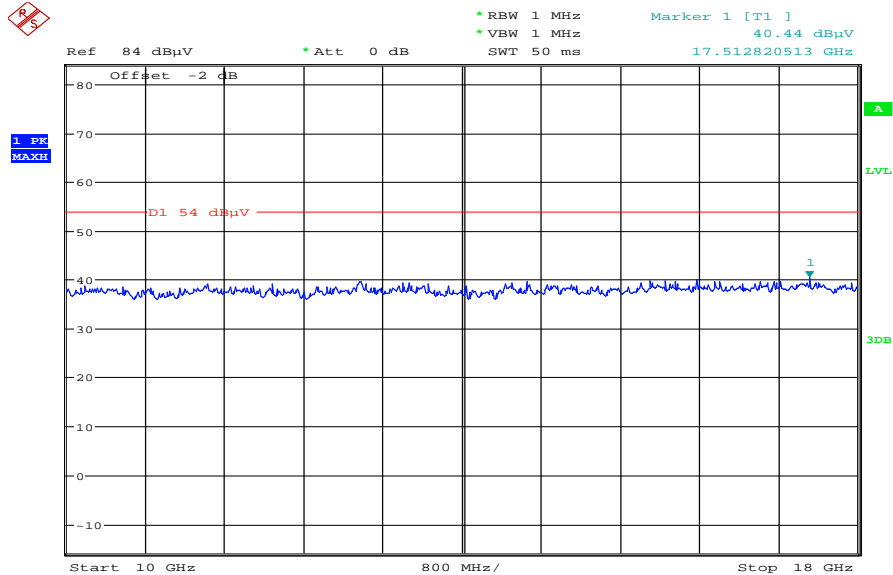

Date: 20.APR.2011 18:20:11

Plot 12: TX mode, highest channel, 18GHz to 25 GHz, vertical & horizontal polarization

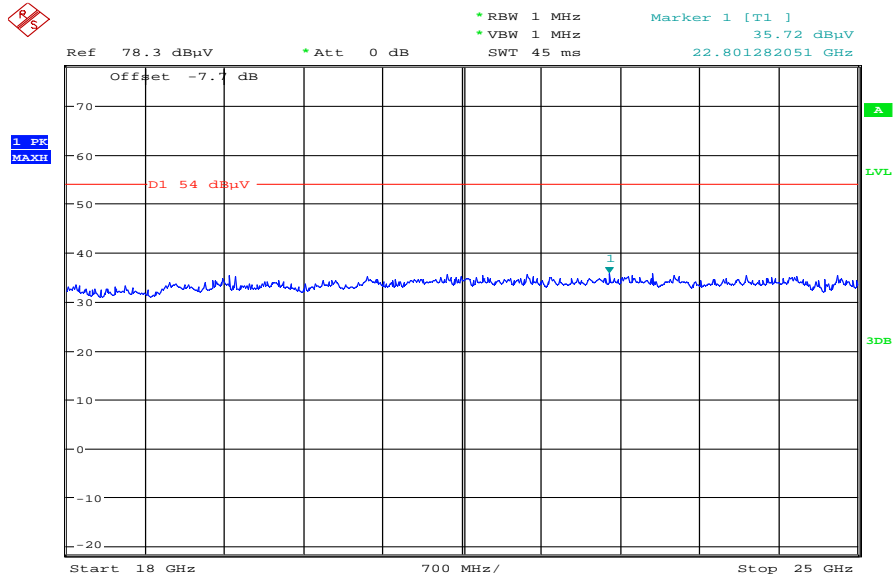

Date: 20.APR.2011 18:15:53

9.12 RX spurious emissions radiated

Description:

Measurement of the radiated spurious emissions in idle/receive mode. The results are valid for both modes.

Measurement:

Measurement parameter	
Detector:	Peak / Quasi Peak
Sweep time:	Auto
Video bandwidth:	Sweep: 100 kHz Remeasurement: 10 Hz
Resolution bandwidth:	F < 1 GHz: 100 kHz F > 1 GHz: 1 MHz
Span:	30 MHz to 25 GHz
Trace-Mode:	Max Hold

Limits:

FCC		IC	
CFR Part 15.109		RSS Gen, Issue 2, 4.10	
RX Spurious Emissions Radiated			
Frequency (MHz)	Field Strength (dB μ V/m)	Measurement distance	
30 - 88	30.0	10	
88 - 216	33.5	10	
216 - 960	36.0	10	
Above 960	54.0	3	

Results:

RX Spurious Emissions Radiated [dB μ V/m]		
F [MHz]	Detector	Level [dB μ V/m]
For emissions below 10 GHz, please take a look at the table below the plots.	For emissions below 10 GHz, please take a look at the table below the plots.	For emissions below 10 GHz, please take a look at the table below the plots.
For emissions above 10 GHz, please take a look at the plots.	For emissions above 10 GHz, please take a look at the plots.	For emissions above 10 GHz, please take a look at the plots.
Measurement uncertainty	± 3 dB	

Result: The measurement is passed.

Plots: RX / Idle – mode

Plot 1: 30 MHz to 1 GHz, vertical & horizontal polarization

Common Information

EUT: T640
 Serial Number: 55800032
 Test Description: FCC 15
 Operating Conditions: RX + charging
 Operator Name: Hennemann
 Comment: Power 115 V / 60 Hz

Scan Setup: STAN_Fin [EMI radiated]

Hardware Setup: Electric Field (NOS)
 Level Unit: dBµV/m

Subrange	Detectors	IF Bandwidth	Meas. Time	Receiver
30 MHz - 2 GHz	QuasiPeak	120 kHz	15 s	Receiver

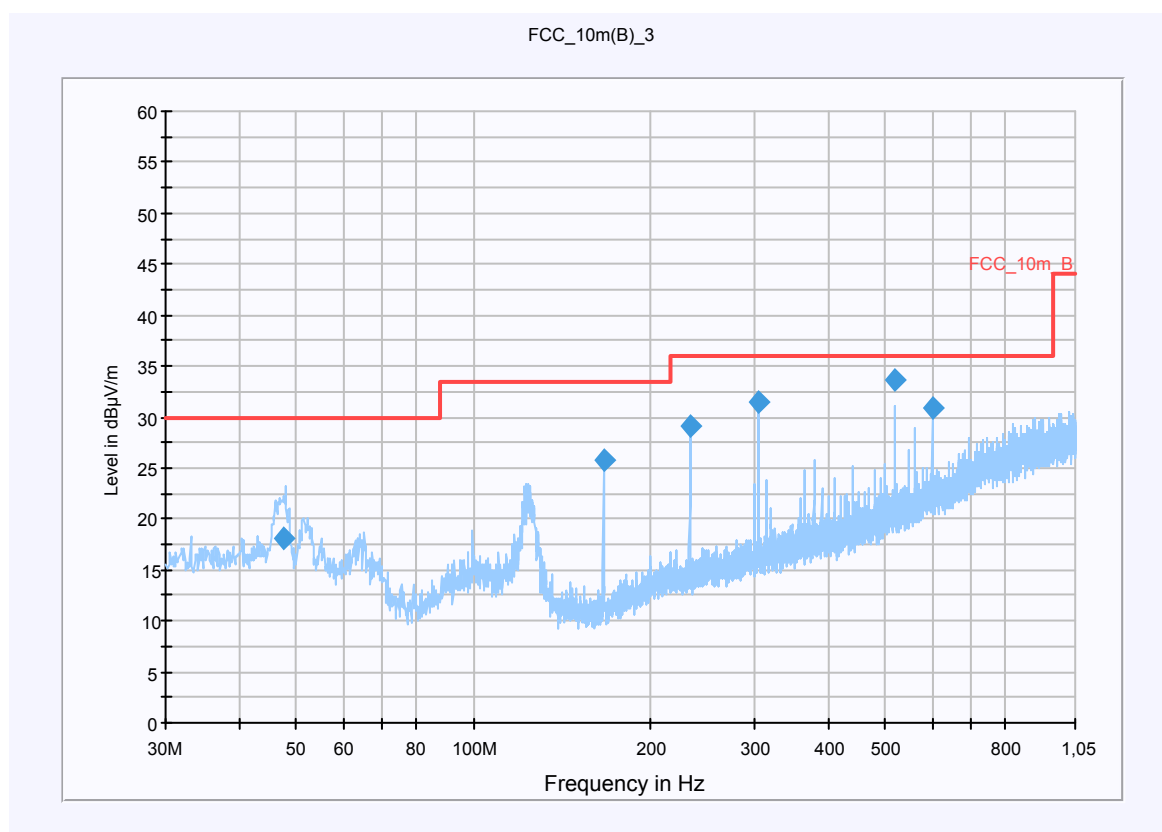

Final Result 1

Frequency (MHz)	QuasiPeak (dBµV/m)	Meas. Time (ms)	Bandwidth (kHz)	Antenna height (cm)	Polarity	Turntable position (deg)	Corr. (dB)	Margin (dB)	Limit (dBµV/m)	Comment
47.592750	18.2	15000.000	120.000	100.0	V	196.0	13.3	11.8	30.0	
166.228950	25.7	15000.000	120.000	100.0	V	106.0	9.6	7.8	33.5	
232.741050	29.0	15000.000	120.000	108.0	V	179.0	12.8	7.0	36.0	
304.748700	31.5	15000.000	120.000	350.0	H	166.0	14.7	4.5	36.0	
519.995100	33.7	15000.000	120.000	150.0	H	83.0	19.0	2.3	36.0	
599.991600	31.0	15000.000	120.000	150.0	H	-6.0	20.8	5.0	36.0	

Hardware Setup: EMI radiated\Electric Field (NOS) - [EMI radiated]

Subrange 1

Frequency Range:	30 MHz - 2 GHz
Receiver:	Receiver [ESCI 3] @ GPIB0 (ADR 20), SN 100083/003, FW 4.42
Signal Path:	without Notch FW 1.0
Antenna:	VULB 9163 SN 9163-295, FW --- Correction Table (vertical): VULP6113 Correction Table (horizontal): VULP6113 Correction Table: Cable_EN_1GHz (1005)
Antenna Tower:	Tower [EMCO 2090 Antenna Tower] @ GPIB0 (ADR 8), FW REV 3.12
Turntable:	Turntable [EMCO Turntable] @ GPIB0 (ADR 9), FW REV 3.12

EMC 32 Version 8.10.00

Plot 2: 1 GHz to 10 GHz, vertical & horizontal polarization

Common Information

EUT: T640
 Serial Number: 55800032
 Test Description: FCC 15
 Operating Conditions: RX + charging
 Operator Name: Hennemann
 Comment: Power 115 V / 60 Hz

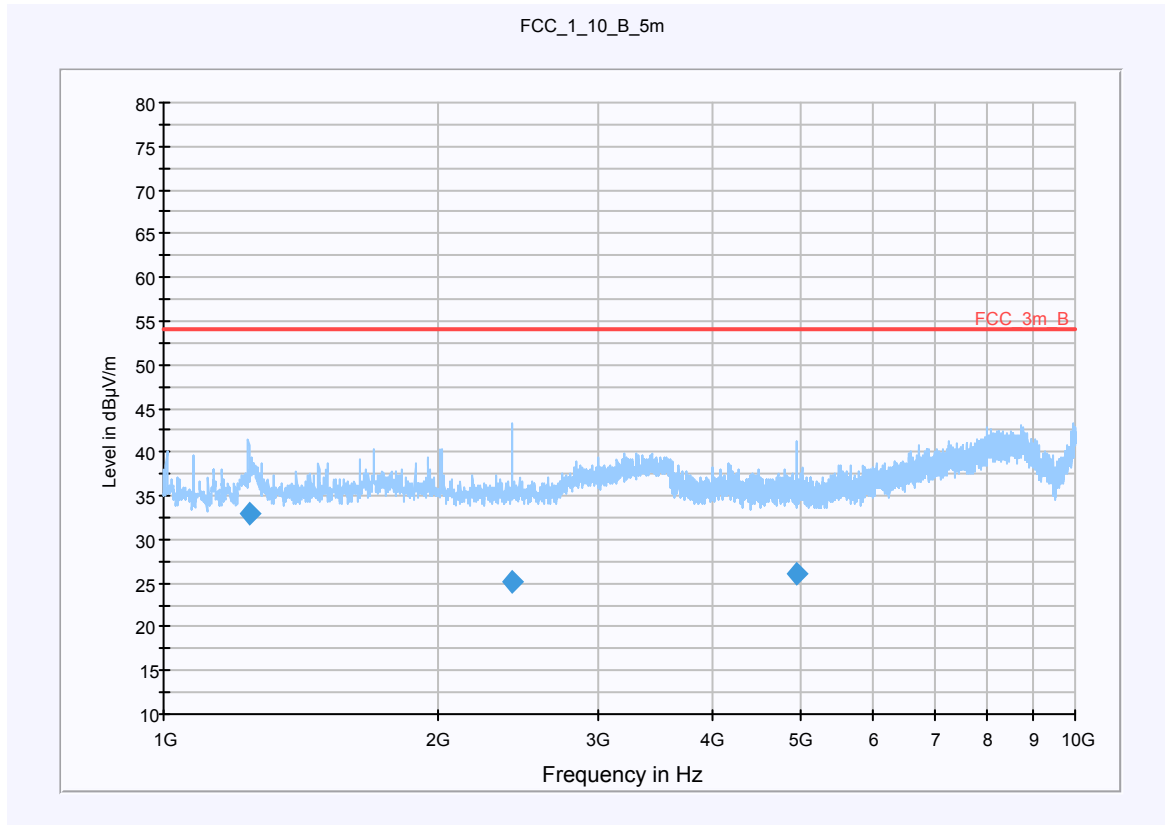

Final Result 1

Frequency (MHz)	Average (dBµV/m)	Meas. Time (ms)	Bandwidth (kHz)	Antenna height (cm)	Polarity	Turntable position (deg)	Corr. (dB)	Margin (dB)	Limit (dBµV/m)	Comment
1240.156654	32.9	100.000	1000.000	100.0	V	97.0	-2.8	21.1	54.0	
2412.169948	25.1	100.000	1000.000	100.0	V	259.0	-4.1	28.9	54.0	
4941.370448	26.0	100.000	1000.000	100.0	V	54.0	-1.3	28.0	54.0	

Hardware Setup: EMI radiated\C_MATRIX - [EMI radiated]

Subrange 1

Frequency Range: 1 GHz - 4 GHz

Receiver: ESU [ESU 26]
@ GPIB0 (ADR 17), SN 100037/026, FW 4.43

Signal Path: EN_NOTCH
FW 1.0
Correction Table: LNA_EN (Notch)
Correction Table: 3_5m

Antenna: BBHA 9120 B
Correction Table (vertical): BBHA9120
Correction Table (horizontal): BBHA9120
Correction Table: Cable_Horn_EN (1103)

Antenna Tower: Generic Tripod [Generic Tripod]
@ GPIB0 (ADR 19), SN ?

Turntable: Turntable [EMCO Turntable]
@ GPIB0 (ADR 9), FW REV 3.12

Subrange 2

Frequency Range: 4 GHz - 10 GHz

Receiver: ESU [ESU 26]
@ GPIB0 (ADR 17), SN 100037/026, FW 4.43

Signal Path: EN_HP
Correction Table: 3_5m
Correction Table: LNA_EN (HP)

Antenna: BBHA 9120 B
Correction Table (vertical): BBHA9120
Correction Table (horizontal): BBHA9120
Correction Table: Cable_Horn_EN (1103)

Antenna Tower: Generic Tripod [Generic Tripod]
@ GPIB0 (ADR 19), SN ?

Turntable: Turntable [EMCO Turntable]
@ GPIB0 (ADR 9), FW REV 3.12

Plot 3: 10 GHz to 18 GHz, vertical & horizontal polarization

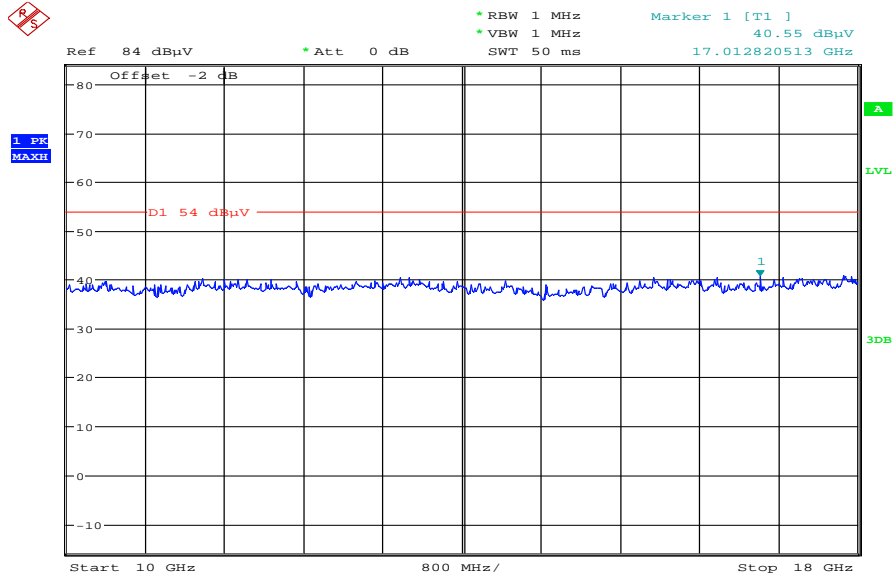

Date: 21.APR.2011 16:00:13

Plot 4: 18 GHz to 25 GHz, vertical & horizontal polarization

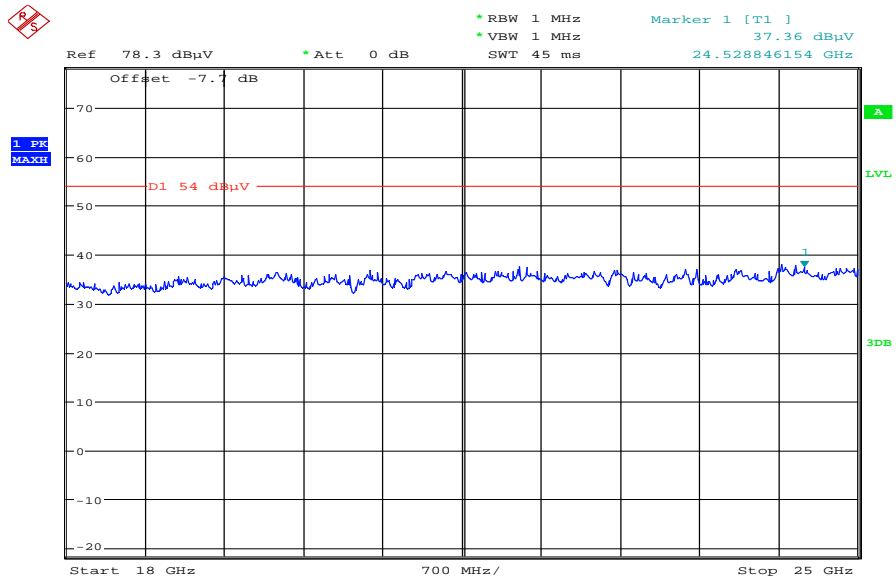

Date: 21.APR.2011 15:59:09

9.13 TX spurious emissions radiated < 30 MHz

Not performed

9.14 TX spurious emissions conducted < 30 MHz

Description:

Measurement of the conducted spurious emissions in transmit mode below 30 MHz. The EUT is set to single channel mode and the transmit channel is channel 39. This measurement is representative for all channels and modes. If critical peaks are found channel 00 and channel 78 will be measured too. The measurement is performed in the mode with the highest output power. Both power lines, phase and neutral line, are measured. Found peaks are remeasured with average and quasi peak detection to show compliance to the limits.

Measurement:

Measurement parameter	
Detector:	Peak - Quasi peak / average
Sweep time:	Auto
Video bandwidth:	F < 150 kHz: 200 Hz F > 150 kHz: 9 kHz
Resolution bandwidth:	F < 150 kHz: 1 kHz F > 150 kHz: 100 kHz
Span:	9 kHz to 30 MHz
Trace-Mode:	Max Hold

Limits:

FCC		IC	
CFR Part 15.107(a)		ICES-003, Issue 4	
TX spurious emissions conducted < 30 MHz			
Frequency (MHz)	Quasi-peak (dBµV/m)	Average (dBµV/m)	
0.15 – 0.5	66 to 56*	56 to 46*	
0.5 – 5	56	46	
5 – 30.0	60	50	

*Decreases with the logarithm of the frequency

Results:

TX spurious emissions conducted < 30 MHz [dBµV/m]		
F [MHz]	Detector	Level [dBµV/m]
No critical peaks detected		
Measurement uncertainty	± 3 dB	

Result: The measurement is passed.

Plots:

Plot 1: 9 kHz to 30 MHz, TX mode, phase line

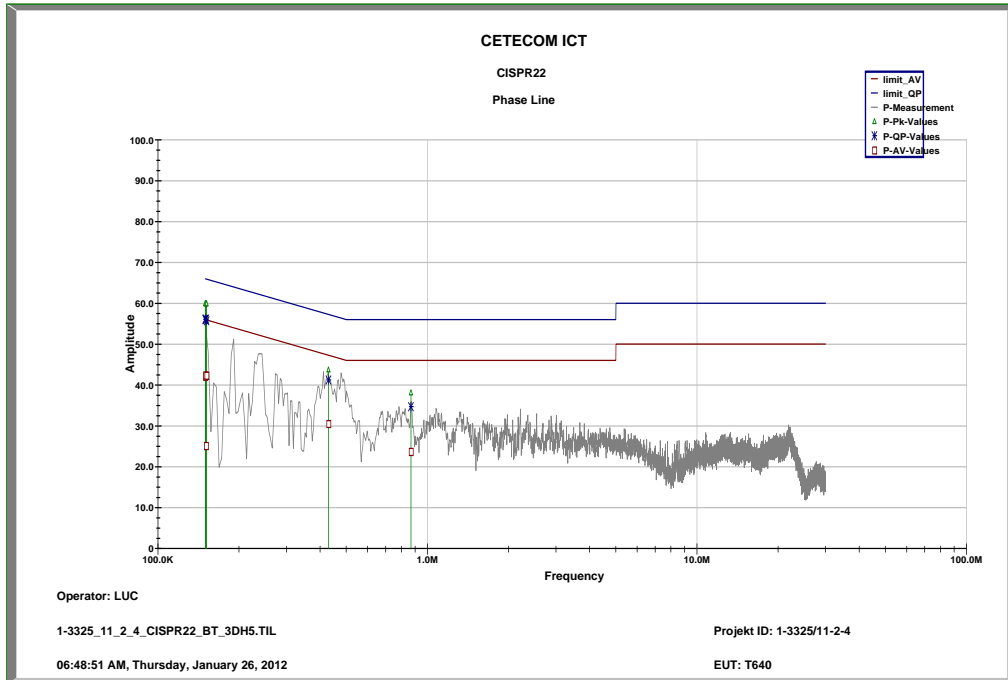

Plot 2: 9 kHz to 30 MHz, TX mode, neutral line

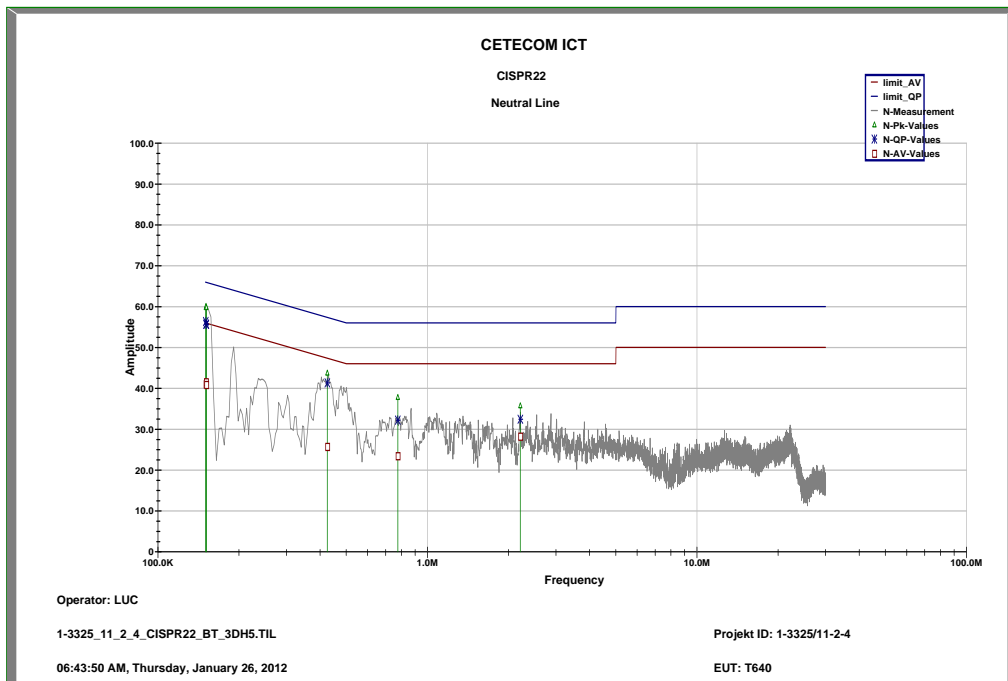

Plot 3: 9 kHz to 30 MHz, RX mode, phase line

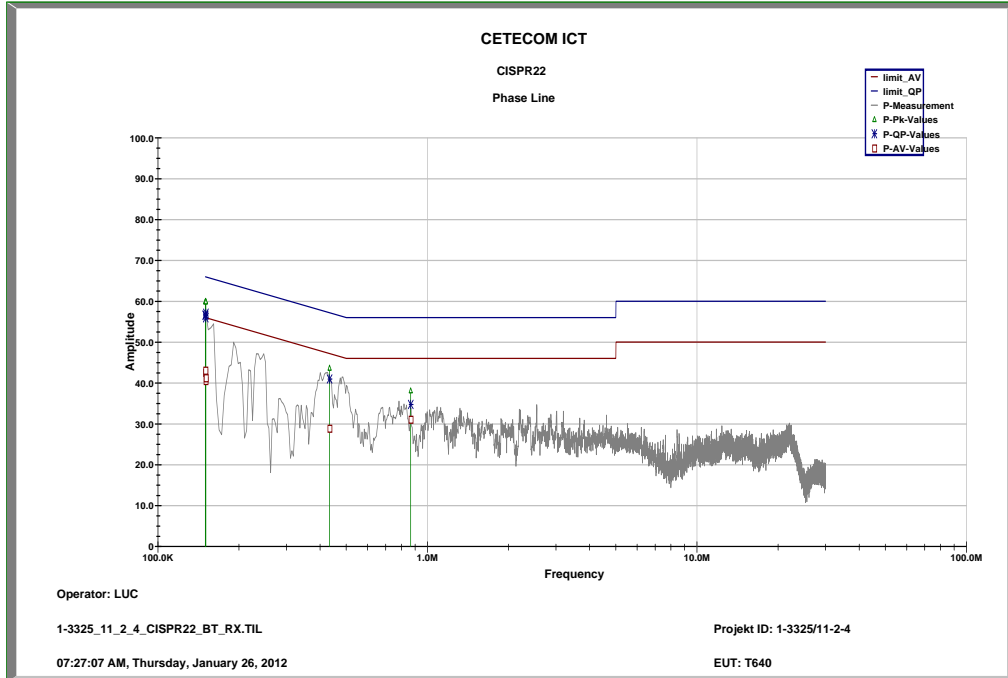

Plot 4: 9 kHz to 30 MHz, RX mode, neutral line

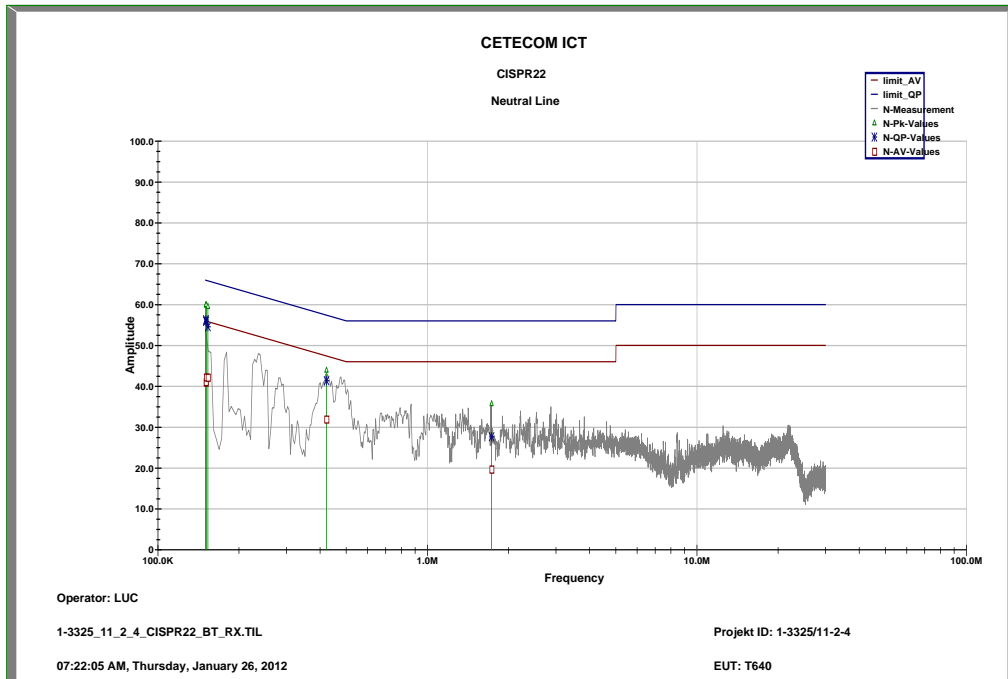

10 Test equipment and ancillaries used for tests

Typically, the calibrations of the test apparatus are commissioned to and performed by an accredited calibration laboratory. The calibration intervals are determined in accordance with the DIN EN ISO/IEC 17025. In addition to the external calibrations, the laboratory executes comparison measurements with other calibrated test systems or effective verifications. Weekly chamber inspections and range calibrations are performed. Where possible, rf-generating and signalling equipment as well as measuring receivers and analyzers are connected to an external high-precision 10 MHz reference (GPS-based or rubidium frequency standard).

In order to simplify the identification of the equipment used at some special tests, some items of test equipment and ancillaries can be provided with an identifier or number in the equipment list below (Labor/Item).

No.	Lab / Item	Equipment	Type	Manufact.	Serial No.	INV. No Cetecom	Kind of Calibration	Last Calibration	Next Calibration
1	n. a.	Spectrum Analyzer 20 Hz - 50 GHz	FSU50	R&S	200012	300003443	ve	01.07.2010	01.07.2012
2	n. a.	Relais Matrix	PSU	R&S	890167/024	300001168	ne		
3	n. a.	Isolating Transformer	RT5A	Grundig	9242	300001263	ne		
4	n. a.	TILE-Software Emission	Quantum Change, Modell TILE-ICS/FULL	EMCO	none	300003451	ne		
5	n. a.	PSA Spectrum Analyzer 3 Hz - 26.5 GHz	E4440A	Agilent Technologies	MY48250080	300003812	k	08.09.2010	08.09.2012
6	n. a.	RF Filter Section 9kHz - 1GHz	N9039A	Agilent Technologies	MY48260003	300003825	vKI!	08.09.2010	08.09.2012
7	45	Switch-Unit	3488A	HP Meßtechnik	2719A14505	300000368	g		
8	n. a.	software	SPS_PHE 1.4f	Spitzberger & Spielf	B5981; 5D1081; B5979	300000210	ne		
9	n. a.	EMI Test Receiver	ESCI 1166.5950.03	R&S	100083	300003312	k	05.01.2011	05.01.2013
10	n. a.	Amplifier	JS42-00502650-28-5A	MITEQ	1084532	300003379	ev		
11	n. a.	Antenna Tower	Model 2175	ETS-LINDGREN	64762	300003745	izw		
12	n. a.	Positioning Controller	Model 2090	ETS-LINDGREN	64672	300003746	izw		
13	n. a.	Turntable Interface-Box	Model 105637	ETS-LINDGREN	44583	300003747	izw		
14	n. a.	TRILOG Broadband Test-Antenna 30 MHz - 3 GHz	VULB9163	Schwarzbeck	295	300003787	k	01.04.2010	01.04.2012
15	n. a.	Spectrum-Analyzer	FSU26	R&S	200809	300003874	k	10.01.2011	10.01.2013
16	n. a.	Isolating Transformer	RT5A	Grundig	8041	300001626	g		
17	n. a.	DC power supply, 60Vdc, 50A, 1200 W	6032A	HP Meßtechnik	2818A03450	300001040	Ve	08.01.2009	08.01.2012
18	n. a.	Coaxial Attenuator 30dB/500W	8325	Bird	1530	300001595	ev		
19	n. a.	Active Loop Antenna	6502	EMCO	2210	300001015	ne		
20	n. a.	Anechoic chamber	FAC 3/5m	MWB / TDK	87400/02	300000996		23.03.2009	
21	Spec.A. 2_2e	System rack for EMI measurement solution	85900	HP I.V.	*	300000222	ne		
22	n. a.	Relais Matrix	3488A	HP Meßtechnik	2719A15013	300001156	ne		
23	n. a.	Relais Matrix	PSU	R&S	890167/024	300001168	ne		
24	n. a.	Isolating Transformer	RT5A	Grundig	9242	300001263	ne		
25	n. a.	Three-Way Power Splitter, 50 Ohm	11850C	HP Meßtechnik		300000997	ne		

26	n. a.	Switch / Control Unit	3488A	HP	2605e08770	300001443	ne		
27	n. a.	Amplifier	js42-00502650-28-5a	Parzich GMBH	928979	300003143	ne		
28	n. a.	Band Reject filter	WRCG1855/1910-1835/1925-40/8SS	Wainwright	7	300003350	ev		
29	n. a.	Band Reject filter	WRCG2400/2483-2375/2505-50/10SS	Wainwright	11	300003351	ev		
30	n. a.	TILE-Software Emission	Quantum Change, Modell TILE-ICS/FULL	EMCO	none	300003451	ne		
31	n. a.	Highpass Filter	WHKX2.9/18G-12SS	Wainwright	1	300003492	ev		
32	n. a.	Highpass Filter	WHK1.1/15G-10SS	Wainwright	3	300003255	ev		
33	n. a.	Highpass Filter	WHKX7.0/18G-8SS	Wainwright	18	300003789	ne		
34	n. a.	MXG Microwave Analog Signal Generator	N5183A	Agilent Technologies	MY47420220	300003813	k	13.09.2010	13.09.2012
35	A014	Std. Gain Horn Antenna 9.84-15.0 GHz	1724-20	Flann	89	300001957	ne		
36	A016	Std. Gain Horn Antenna 14.5-22.0 GHz	1924-20	Flann	33	300001963	ne		
37	A019	Std. Gain Horn Antenna 17.6-26.7 GHz	2024-20	Flann	156	300001968	ne		

Agenda: Kind of Calibration

- | | | | |
|------|--|-----|--|
| k | calibration / calibrated | EK | limited calibration |
| ne | not required (k, ev, izw, zw not required) | zw | cyclical maintenance (external cyclical maintenance) |
| ev | periodic self verification | izw | internal cyclical maintenance |
| Ve | long-term stability recognized | g | blocked for accredited testing |
| vkI! | Attention: extended calibration interval | * | next calibration ordered / currently in progress |
| NK! | Attention: not calibrated | | |

11 Observations

No observations exceeding those reported with the single test cases have been made.

Annex A Photographs of the test setup

Photo documentation:

Photo 1:



Photo 2:



Photo 3: (Chamber F)



Photo 4: (Chamber F)



Photo 5: (Chamber F)

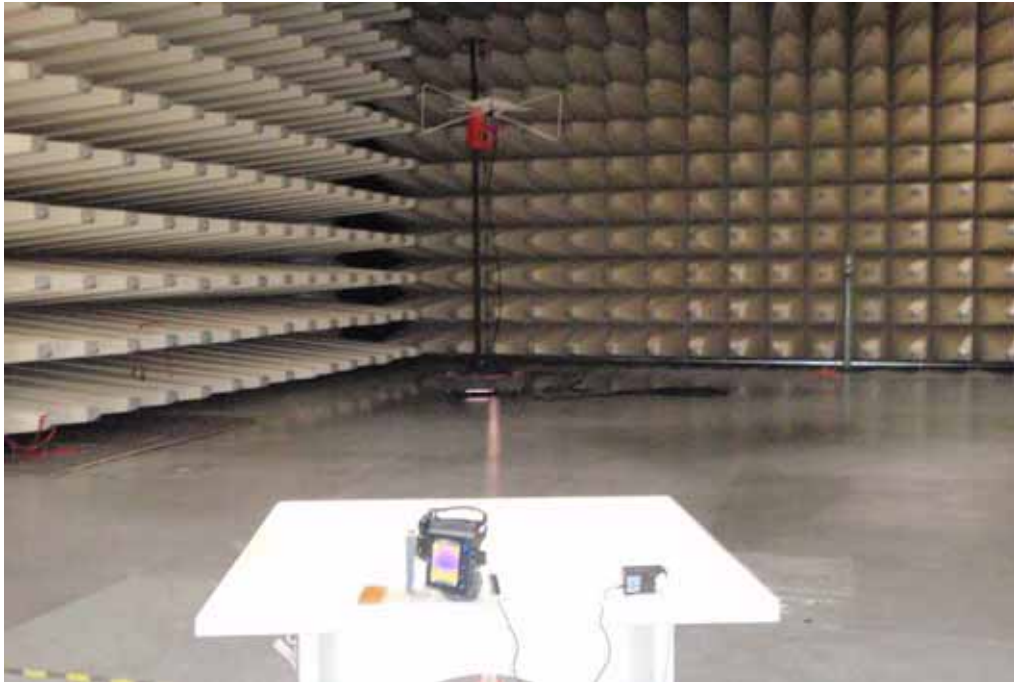

Annex B External photographs of the EUT

Photo documentation:

Photo 1:



Photo 2:



Photo 3:



Photo 4:



Photo 5:



Photo 6:



Photo 7:



Photo 8:



Photo 9:



Photo 10:



Photo 11:



Annex C Internal photographs of the EUT

Photo documentation:

Photo 1:



Photo 2:



Photo 3:



Photo 4:



Photo 5:



Photo 6:



Photo 7:



Photo 8:



Photo 9:



Annex D Document history

Version	Applied changes	Date of release
1.0	Initial release	2012-02-07
-A	Merge with radiated measurements This report replaces the report 1-3325/11-02-04 dated 2012-02-07	2012-02-23

Annex E Further information

Glossary

AVG	-	Average
DUT	-	Device under test
EMC	-	Electromagnetic Compatibility
EN	-	European Standard
EUT	-	Equipment under test
ETSI	-	European Telecommunications Standard Institute
FCC	-	Federal Communication Commission
FCC ID	-	Company Identifier at FCC
HW	-	Hardware
IC	-	Industry Canada
Inv. No.	-	Inventory number
N/A	-	Not applicable
PP	-	Positive peak
QP	-	Quasi peak
S/N	-	Serial number
SW	-	Software

Annex F Accreditation Certificate



Front side of certificate



Back side of certificate

Note:

The current certificate including annex is published on our website (see link below) or may be received from CETECOM ICT Services on request.

http://www.cetecom.com/fileadmin/de/CETECOM_D_Saarbruecken/accreditations_Jan_2010/DAKKS_Akkredi_Urk_EN17025-En_incl_Annex.pdf