



FCC TEST REPORT

according to

FCC Rules and Regulations Part 15 Subpart C

Applicant : FLIR Systems AB

Address : SE 18715, Täby, Sweden

Equipment : Digital Multimeter

Model No. : DM93

FCC ID : ZLV-DM93

Trade Name : FLIR

- The test result refers exclusively to the test presented test model / sample.,
- Without written approval of **CerpPASS Technology Corp.** the test report shall not be reproduced except in full.
- The EUT is also considered as a kind of computer peripheral, because the connection to computer is necessary for typical use. It has been verified to comply with the requirements of FCC Part 15, Subpart B, Class B (DoC). The test report has been issued separately.



Contents

1. Report of Measurements and Examinations	6
1.1 List of Measurements and Examinations	6
2. Test Configuration of Equipment under Test	7
2.1 Feature of Equipment under Test	7
2.2 Carrier Frequency of Channels	7
2.3 Test Mode & Test Software	8
2.4 Description of Test System	8
2.5 General Information of Test	9
2.6 Measurement Uncertainty	9
3. Antenna Requirements	10
3.1 Standard Applicable	10
3.2 Antenna Construction and Directional Gain	10
4. Test of Conducted Emission	11
4.1 Test Limit	11
4.2 Test Procedures	11
4.3 Typical Test Setup	12
4.4 Test Result and Data	12
5. Test of Radiated Emission	13
5.1 Test Limit	13
5.2 Test Procedures	13
5.3 Typical Test Setup	14
5.4 Measurement equipment	14
5.5 Test Result and Data (9kHz ~ 30MHz)	15
5.6 Test Result and Data (30MHz ~ 1GHz)	15
5.7 Test Result and Data (1GHz ~ 25GHz)	27
5.8 Test Photographs (30MHz ~ 1GHz)	45
5.9 Test Photographs (1GHz ~ 25GHz)	46
6. 20dB Bandwidth Measurement Data	47
6.1 Test Limit	47
6.2 Test Procedures	47
6.3 Test Setup Layout	47
6.4 Measurement equipment	47
6.5 Test Result and Data	48
7. Frequencies Separation	54
7.1 Test Limit	54
7.2 Test Procedures	54
7.3 Test Setup Layout	54
7.4 Measurement equipment	54
7.5 Test Result and Data	55
8. Dwell Time on each channel	61
8.1 Test Limit	61
8.2 Test Procedures	61
8.3 Test Setup Layout	61



8.4 Measurement equipment 61

8.5 Test Result and Data 62

9. Number of Hopping Channels 71

9.1 Test Limit 71

9.2 Test Procedures 71

9.3 Test Setup Layout 71

9.4 Measurement equipment 71

9.5 Test Result and Data 71

10. Maximum Peak Output Power 74

10.1 Test Limit 74

10.2 Test Procedures 74

10.3 Test Setup Layout 74

10.4 Measurement equipment 74

10.5 Test Result and Data 75

11. Band Edges Measurement 81

11.1 Test Limit 81

11.2 Test Procedure 81

11.3 Test Setup Layout 81

11.4 List of Measuring Equipment Used 81

11.5 Test Result and Data 81

11.6 Restrict band emission Measurement Data 88

12. Restricted Bands of Operation 91

12.1 Labeling Requirement 91

Appendix A. Photographs of EUT A1 ~ A7



CERTIFICATE OF COMPLIANCE

according to

FCC Rules and Regulations Part 15 Subpart C

Applicant : FLIR Systems AB

Address : SE 18715, Täby, Sweden

Equipment : Digital Multimeter

Model No. : DM93

FCC ID : ZLV-DM93

I HEREBY CERTIFY THAT :

The measurements shown in this test report were made in accordance with the procedures given in **ANSI C63.4** The equipment was **passed** the test performed according to **FCC Rules and Regulations Part 15 Subpart C (2010)**.

The test was carried out on Aug. 16, 2013 at **CerpPASS Technology Corp.**

Approval by :

Hill Chen

EMC/RF B.U. Assistant Manager

Test Engineer:

Tom Tai

Engineer



1. Report of Measurements and Examinations

1.1 List of Measurements and Examinations

FCC Rule	Description of Test	Result
15.203	. Antenna Requirement	Pass
15.207	. Conducted Emission	Pass
15.209	. Radiated Emission	Pass
15.247(a)(1)	. Channel Carrier Frequencies Separation	Pass
15.247(a)(1)	. 20dB Bandwidth Measurement	Pass
15.247(a)(1)	. Dwell Time	Pass
15.247(b)	. Number of Hopping Channels	Pass
15.247(b)	. Peak Output Power Measurement Data	Pass
15.247(d)	. Band Edges Measurement Data	Pass



2. Test Configuration of Equipment under Test

2.1 Feature of Equipment under Test

Display	40 000-count with bar
Controls	<ul style="list-style-type: none"> • 6-position rotary function switch • 4-way selector pad with center OK button • (6) dedicated function buttons: mode, range, cancel, hold, Blue-tooth, backlight
Backlight	White LED
Work light	White LED array
Measurement ranges	See section 7.2 Electrical range specifications, page 26
Basic accuracy	0.06%
Measurement rate	20 per second, nominal
Display rate	2 times per second
Input impedance	>10 M Ω V DC, >3 M Ω V AC in Normal mode
	<10 k Ω in Low Impedance mode
AC voltage bandwidth	45 Hz to 1kHz
Power supply	6 x AAA batteries (LR03)
Battery life	100 hours, using alkaline batteries, with no backlight, Bluetooth, or work light use
Auto power off (APO)	After a programmable number of mi-nutes of inactivity, with audible pre-alert ; reset when the function switch or buttons are pressed. Disable function supported.

2.2 Carrier Frequency of Channels

Channel	Frequency (MHz)	Channel	Frequency (MHz)	Channel	Frequency (MHz)	Channel	Frequency (MHz)
00	2402	20	2422	40	2442	60	2462
01	2403	21	2423	41	2443	61	2463
02	2404	22	2424	42	2444	62	2464
03	2405	23	2425	43	2445	63	2465
04	2406	24	2426	44	2446	64	2466
05	2407	25	2427	45	2447	65	2467
06	2408	26	2428	46	2448	66	2468
07	2409	27	2429	47	2449	67	2469
08	2410	28	2430	48	2450	68	2470
09	2411	29	2431	49	2451	69	2471
10	2412	30	2432	50	2452	70	2472
11	2413	31	2433	51	2453	71	2473
12	2414	32	2434	52	2454	72	2474
13	2415	33	2435	53	2455	73	2475
14	2416	34	2436	54	2456	74	2476
15	2417	35	2437	55	2457	75	2477
16	2418	36	2438	56	2458	76	2478
17	2419	37	2439	57	2459	77	2479
18	2420	38	2440	58	2460	78	2480
19	2421	39	2441	59	2461	---	---



2.3 Test Mode & Test Software

- a. During testing, the interface cables and equipment positions were varied according to ANSI C63.4
- b. The following test mode was performed for conduction and radiation test:
 - GFSK: CH 00: 2402MHz, CH 39: 2441MHz, CH 78: 2480MHz.
 - $\pi/44$ -DQPSK: CH 00: 2402MHz, CH 39: 2441MHz, CH 78: 2480MHz.
 - 8DPSK: CH 00: 2402MHz, CH 39: 2441MHz, CH 78: 2480MHz.

2.4 Description of Test System

There is no supporting system during the test



2.5 General Information of Test

Test Site :	CerpPASS Technology Corp. 2F-11, No. 3, Yuan Qu St., (Nankang Software Park), Taipei, Taiwan 115, R.O.C.
Test Site Location (OATS2-SD) :	No.68-1, Shihbachongsi, Shihding Township, Taipei City 223, Taiwan, R.O.C.
FCC Registration Number:	TW1049, TW1061, 390316, 488071
IC Registration Number :	4934B-1, 4934D-1
VCCI Registration Number:	T-1173 for Telecommunication Test C-4139 for Conducted emission test R-3428 for Radiated emission test G-97 for Radiated emission test above 1GHz
Frequency Range Investigated:	Conducted: from 150kHz to 30 MHz Radiation: from 30 MHz to 24800MHz
Test Distance:	The test distance of radiated emission from antenna to EUT is 3 M.
Laboratory Accreditation :	

2.6 Measurement Uncertainty

Measurement Item	Measurement Frequency	Polarization	Uncertainty
Conducted Emission	9 kHz ~ 30 MHz	LINE/NEUTRAL	3.25 dB
Radiated Emission	30 MHz ~ 1,000 MHz	Vertical / Horizontal	3.93 dB
	1,000 MHz ~ 18,000 MHz	Vertical / Horizontal	5.18dB
6 dB Bandwidth	---	---	7500 Hz
Maximum Peak Output Power	---	---	1.4 dB
100kHz Bandwidth of Frequency Band Edges	---	---	2.2 dB
Power Spectral Density	---	---	2.2 dB



3. Antenna Requirements

3.1 Standard Applicable

For intentional device, according to FCC 47 CFR Section 15.203, an intentional radiator shall be designed to ensure that no antenna other than that furnished by the responsible party shall be used with the device.

And according to FCC 47 CFR Section 15.247 (b), if transmitting antennas of directional gain greater than 6dBi are used, the power shall be reduced by the amount in dB that the directional gain of the antenna exceeds 6dBi.

3.2 Antenna Construction and Directional Gain

Antenna type: Chip Antenna

Antenna Gain: 0.9 dBi



4. Test of Conducted Emission

4.1 Test Limit

Conducted Emissions were measured from 150 kHz to 30 MHz with a bandwidth of 9 KHz on the 120 VAC power and return leads of the EUT according to the methods defined in ANSI C63.4-2009 Section 3.1. The EUT was placed on a nonmetallic stand in a shielded room 0.8 meters above the ground plane as shown in section 2.2. The interface cables and equipment positioning were varied within limits of reasonable applications to determine the position produced maximum conducted emissions.

Frequency (MHz)	Quasi Peak (dB μ V)	Average (dB μ V)
0.15 – 0.5	66-56*	56-46*
0.5 – 5.0	56	46
5.0 – 30.0	60	50

*Decreases with the logarithm of the frequency.

4.2 Test Procedures

- a. The EUT was placed 0.4 meter from the conducting wall of the shielding room was kept at least 80 centimeters from any other grounded conducting surface.
- b. Connect EUT to the power mains through a line impedance stabilization network (LISN).
- c. All the support units are connecting to the other LISN.
- d. The LISN provides 50 ohm coupling impedance for the measuring instrument.
- e. The FCC states that a 50 ohm, 50 micro-Henry LISN should be used.
- f. Both sides of AC line were checked for maximum conducted interference.
- g. The frequency range from 150 kHz to 30 MHz was searched.
- h. Set the test-receiver system to Peak Detect Function and Specified Bandwidth with Maximum Hold Mode.



4.3 Typical Test Setup

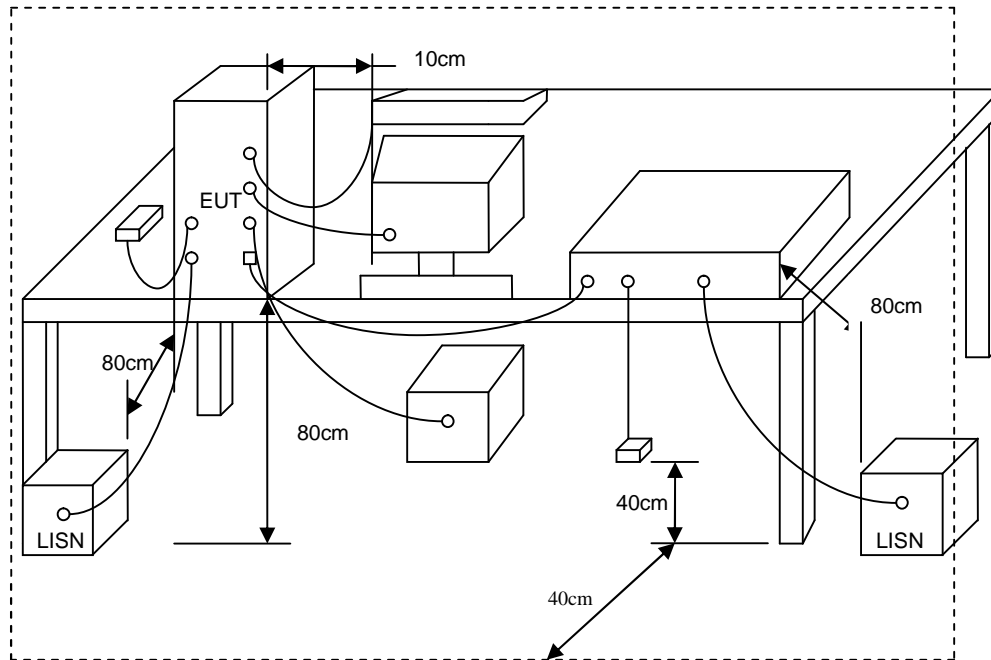

4.4 Test Result and Data

The EUT is powered from Battery; the test item is not applicable.



5. Test of Radiated Emission

5.1 Test Limit

Radiated emissions from 30 MHz to 25 GHz were measured according to the methods defines in ANSI C63.4-2009. The EUT was placed, 0.8 meter above the ground plane, as shown in section 5.6.3. The interface cables and equipment positions were varied within limits of reasonable applications to determine the positions producing maximum radiated emissions For unintentional device, according to § 15.109(a), except for Class A digital devices, the field strength of radiated emissions from unintentional radiators at a distance of 3 meters shall not exceed the following values:

Frequency (MHz)	Distance Meters	Radiated (μ V / M)	Radiated (dB μ V / M)
30-88	3	100	40.0
88-216	3	150	43.5
216-960	3	200	46.0
Above 960	3	500	54.0

For unintentional device, according to CISPR PUB.22, for Class B digital devices, the general requirement of field strength of radiated emissions from intentional radiators at a distance of 10 meters shall not exceed the above table.

Frequency (MHz)	Distance Meters	Radiated (dB μ V / M)
30-230	10	30
230-1000	10	37

5.2 Test Procedures

- The EUT was placed on a rotatable table top 0.8 meter above ground.
- The EUT was set 3 meters from the interference receiving antenna which was mounted on the top of a variable height antenna tower.
- The table was rotated 360 degrees to determine the position of the highest radiation.
- The antenna is a broadband antenna and its height is varied between one meter and four meters above ground to find the maximum value of the field strength both horizontal polarization and vertical polarization of the antenna are set to make the measurement.
- For each suspected emission the EUT was arranged to its worst case and then tune the antenna tower (from 1 M to 4 M) and turn table (from 0 degree to 360 degrees) to find the maximum reading.
- Set the test-receiver system to Peak or CISPR quasi-peak Detect Function and specified bandwidth with Maximum Hold Mode.
- If the emission level of the EUT in peak mode was 3 dB lower than the limit specified, then testing will be stopped and peak values of EUT will be reported, otherwise, the emissions which do not have 3 dB margin will be repeated one by one using the quasi-peak method and reported.
- For testing above 1GHz, the emission level of the EUT in peak mode was 20dB lower than average limit (that means the emission level in peak mode also complies with the limit in average mode), then testing will be stopped and peak values of EUT will be reported, otherwise, the emissions will be measured in average mode again and reported.



5.3 Typical Test Setup

For radiated emissions below 30MHz

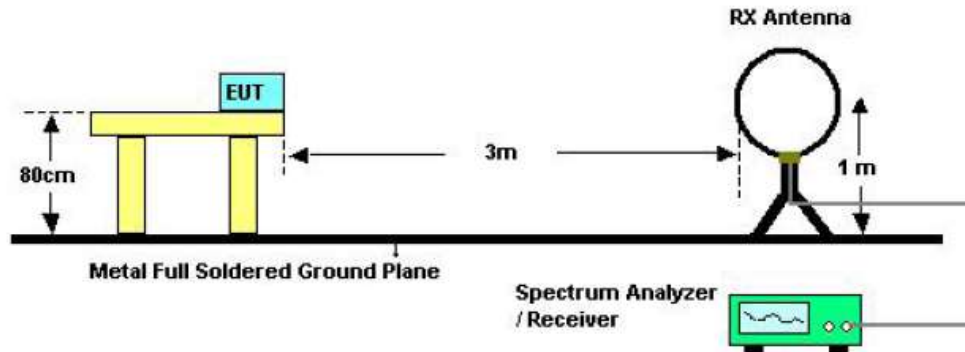

For radiated emissions above 30MHz

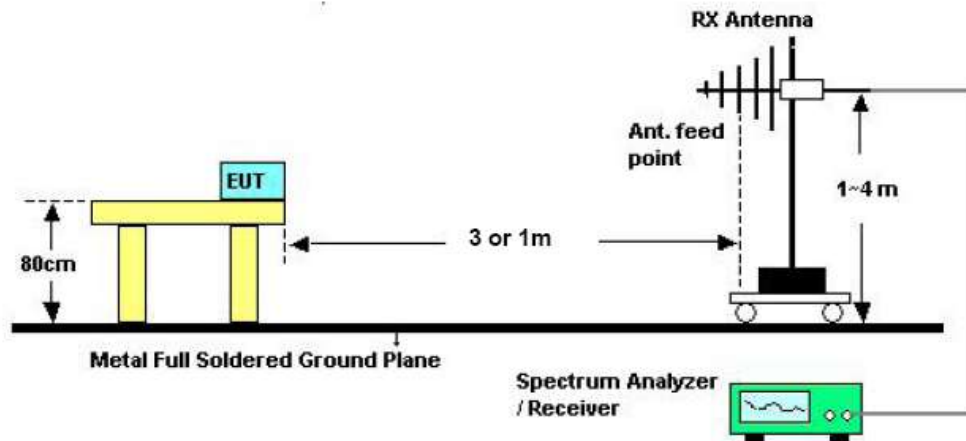

Above 10 GHz shall be extrapolated to the specified distance using an extrapolation factor of 20 dB/decade from 3m to 1m.

Distance extrapolation factor = $20 \log(\text{specific distance [3m]} / \text{test distance [1m]})$ (dB);

Limit line = specific limits (dBuV) + distance extrapolation factor [9.54 dB].

5.4 Measurement equipment

Instrument/Ancillary	Manufacturer	Model No.	Serial No.	Calibration Date	Valid Date
Amplifier	Agilent	8447D	2944A10531	2012/10/17	2013/10/16
Bilog Antenna	Schaffner	CBL6112B	2840	2013/03/27	2014/03/26
EMI Receiver	R&S	ESCI	100443	2013/01/15	2014/01/14
SPECTRUM ANALYZER	R&S	FSP40	100219	2012/09/13	2013/09/12
HORN ANTENNA	EMCO	3115	31601	2012/09/13	2013/09/12
PREAMPLIFIER	EMC	EMC012635	980029	2012/09/12	2013/09/11
Preamplifier	Agilent	8449B	3008A01954	2013/03/07	2014/03/06
Loop Antenna	EMCO	6507	40855	2012/11/23	2013/11/22



5.5 Test Result and Data (9kHz ~ 30MHz)

The 9kHz-30MHz spurious emission is under limit 20dB more.

5.6 Test Result and Data (30MHz ~ 1GHz)

Power	: DC 9V By Battery	Pol/Phase	: VERTICAL
Test Mode	: Transmit / Receive	Temperature	: 26 °C
Operation Channel	: 0	Humidity	: 48 %
Modulation Type	: GFSK (1 Mbps)	Atmospheric Pressure	: 1018 hPa

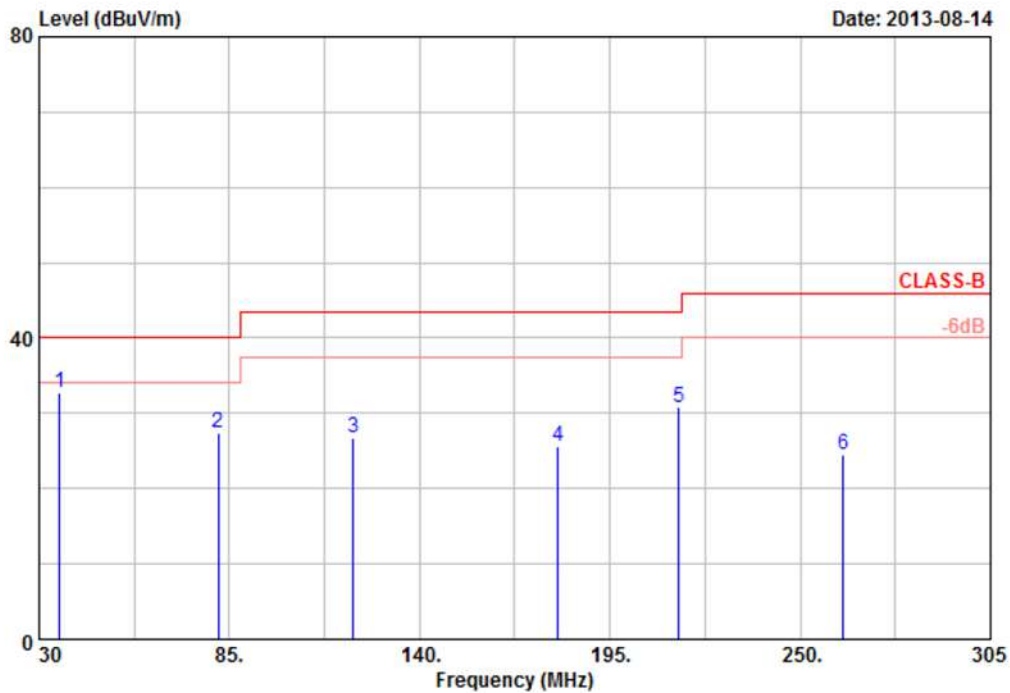

Item	Freq MHz	Read Value dBuV	Factor dB/m	Result dBuV/m	Limit dBuV/m	Margin dB	Remark	Ant Pos cm	Tab Pos Deg
1	36.05	34.74	-1.94	32.80	40.00	-7.20	Peak	100	360
2	81.70	34.85	-7.52	27.33	40.00	-12.67	Peak	100	360
3	120.75	31.36	-4.69	26.67	43.50	-16.83	Peak	100	360
4	179.88	30.60	-5.06	25.54	43.50	-17.96	Peak	100	360
5	214.80	37.73	-6.99	30.74	43.50	-12.76	Peak	100	360
6	262.38	31.97	-7.50	24.47	46.00	-21.53	Peak	100	360

Remarks: 1. Result = Read Value + Factor
 2. Factor = Antenna Factor + Cable Loss - Amplifier
 3. According to technical experiences, all spurious emission of BT mode at channel 0,39,78 are almost the same below 1GHz, so that the channel 0 was chosen as representative in final test.
 4. The data is worst case.



Power	: DC 9V By Battery	Pol/Phase	: VERTICAL
Test Mode	: Transmit / Receive	Temperature	: 26 °C
Operation Channel	: 0	Humidity	: 48 %
Modulation Type	: GFSK (1 Mbps)	Atmospheric Pressure	: 1018 hPa

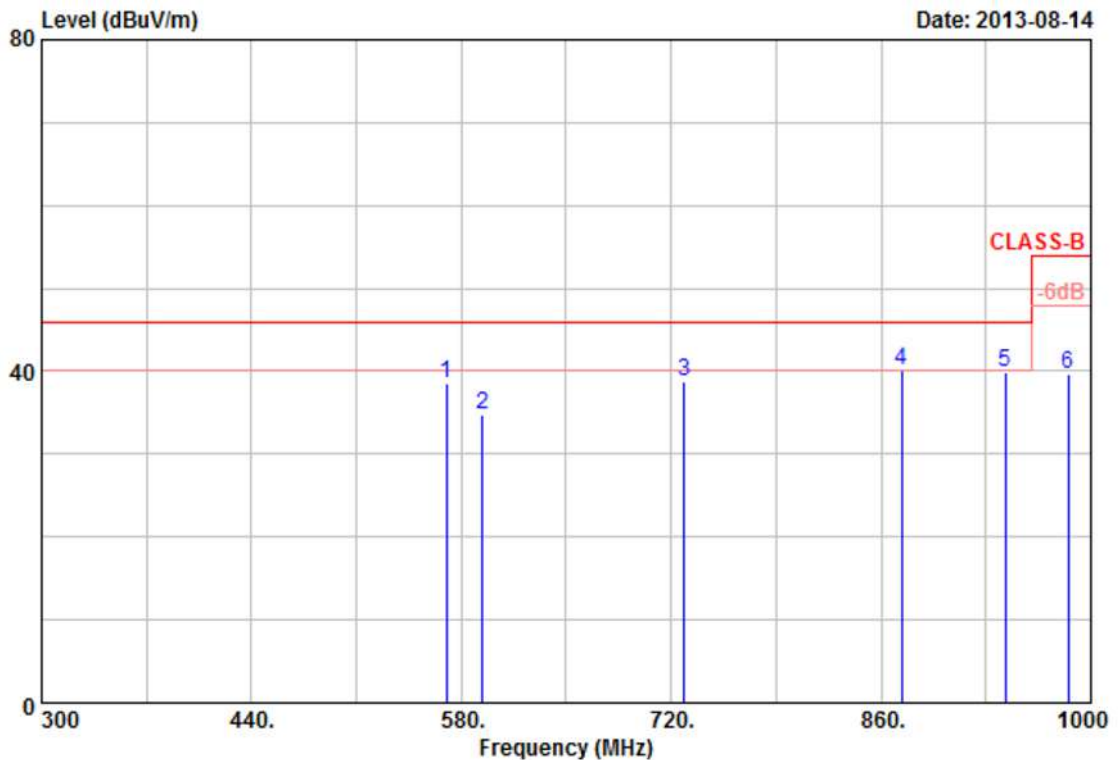

Item	Freq	Read Value	Factor	Result	Limit	Margin	Remark	Ant Pos	Tab Pos
	MHz	dBuV	dB/m	dBuV/m	dBuV/m	dB		cm	Deg
1	570.20	31.00	7.59	38.59	46.00	-7.41	Peak	100	0
2	594.00	31.24	3.62	34.86	46.00	-11.14	Peak	100	0
3	728.40	31.92	6.82	38.74	46.00	-7.26	Peak	100	0
4	874.00	30.61	9.47	40.08	46.00	-5.92	QP	100	0
5	942.60	28.59	11.30	39.89	46.00	-6.11	QP	100	0
6	984.60	31.60	7.97	39.57	54.00	-14.43	Peak	100	0

- Remarks:
1. Result = Read Value + Factor
 2. Factor = Antenna Factor + Cable Loss - Amplifier
 3. According to technical experiences, all spurious emission of BT mode at channel 0,39,78 are almost the same below 1GHz, so that the channel 0 was chosen as representative in final test.
 4. The data is worst case.



Power	: DC 9V By Battery	Pol/Phase	: HORIZONTAL
Test Mode	: Transmit / Receive	Temperature	: 26 °C
Operation Channel	: 0	Humidity	: 48 %
Modulation Type	: GFSK (1 Mbps)	Atmospheric Pressure	: 1018 hPa

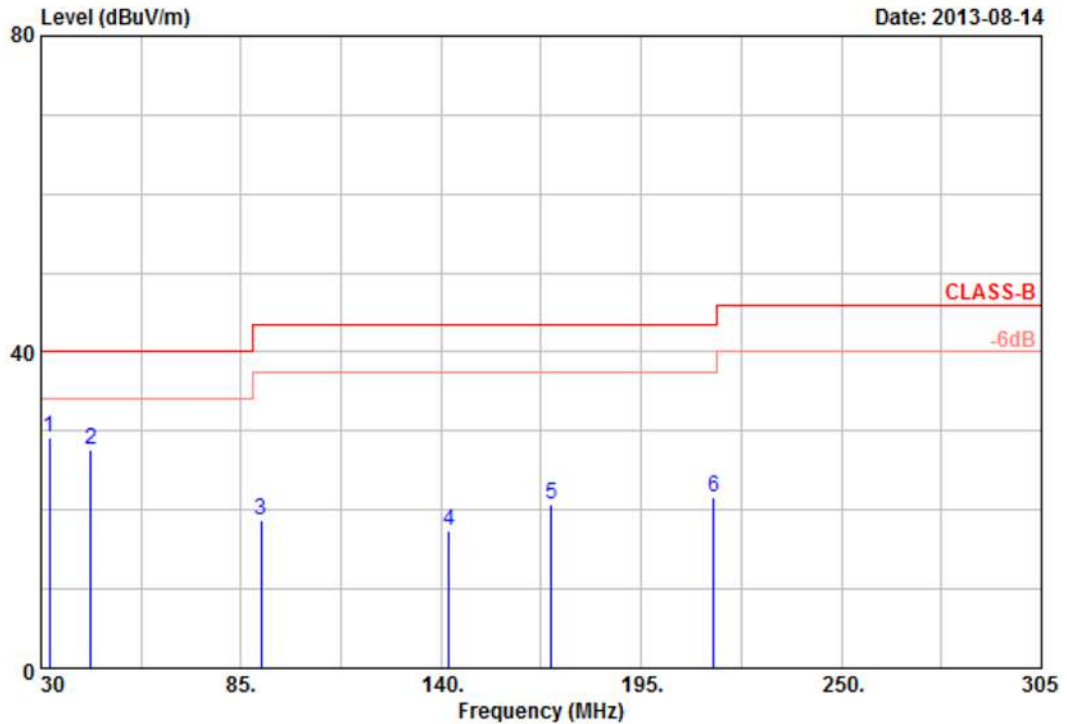

Item	Freq	Read Value	Factor	Result	Limit	Margin	Remark	Ant Pos	Tab Pos
	MHz	dBuV	dB/m	dBuV/m	dBuV/m	dB		cm	Deg
1	32.20	35.40	-6.16	29.24	40.00	-10.76	Peak	100	360
2	43.75	35.75	-8.03	27.72	40.00	-12.28	Peak	100	360
3	90.50	37.21	-18.43	18.78	43.50	-24.72	Peak	100	360
4	142.20	31.93	-14.65	17.28	43.50	-26.22	Peak	100	360
5	170.25	31.96	-11.29	20.67	43.50	-22.83	Peak	100	360
6	214.80	38.01	-16.46	21.55	43.50	-21.95	Peak	100	360

Remarks: 1. Result = Read Value + Factor
 2. Factor = Antenna Factor + Cable Loss - Amplifier
 3. According to technical experiences, all spurious emission of BT mode at channel 0,39,78 are almost the same below 1GHz, so that the channel 0 was chosen as representative in final test.
 4. The data is worst case.



Power	: DC 9V By Battery	Pol/Phase	: HORIZONTAL
Test Mode	: Transmit / Receive	Temperature	: 26 °C
Operation Channel	: 0	Humidity	: 48 %
Modulation Type	: GFSK (1 Mbps)	Atmospheric Pressure	: 1018 hPa

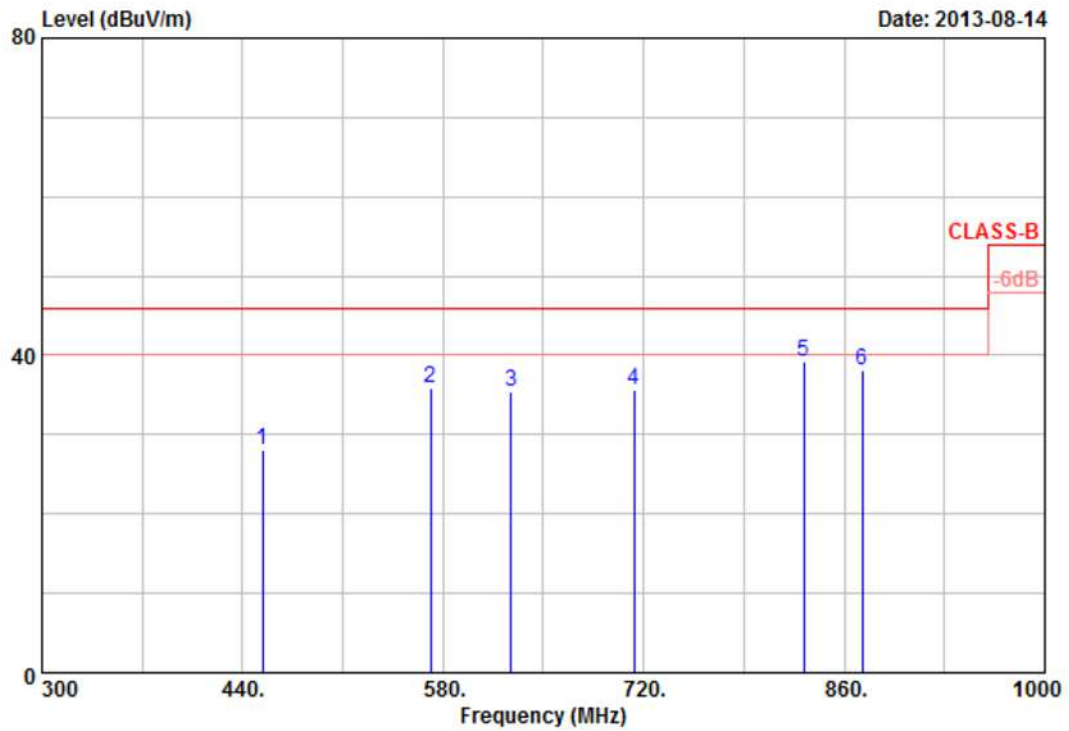

Item	Freq	Read Value	Factor	Result	Limit	Margin	Remark	Ant Pos	Tab Pos
	MHz	dBuV	dB/m	dBuV/m	dBuV/m	dB		cm	Deg
1	454.00	32.64	-4.67	27.97	46.00	-18.03	Peak	100	0
2	571.60	32.94	2.88	35.82	46.00	-10.18	Peak	100	0
3	627.60	31.41	3.92	35.33	46.00	-10.67	Peak	100	0
4	713.00	32.54	3.11	35.65	46.00	-10.35	Peak	100	0
5	832.00	30.60	8.70	39.30	46.00	-6.70	Peak	100	0
6	872.60	33.37	4.81	38.18	46.00	-7.82	Peak	100	0

Remarks: 1. Result = Read Value + Factor
 2. Factor = Antenna Factor + Cable Loss - Amplifier
 3. According to technical experiences, all spurious emission of BT mode at channel 0,39,78 are almost the same below 1GHz, so that the channel 0 was chosen as representative in final test.
 4. The data is worst case.



Power	: DC 9V By Battery	Pol/Phase	: VERTICAL
Test Mode	: Transmit / Receive	Temperature	: 26 °C
Operation Channel	: 0	Humidity	: 48 %
Modulation Type	: $\pi/4$ -DQPSK (2 Mbps)	Atmospheric Pressure	: 1018 hPa

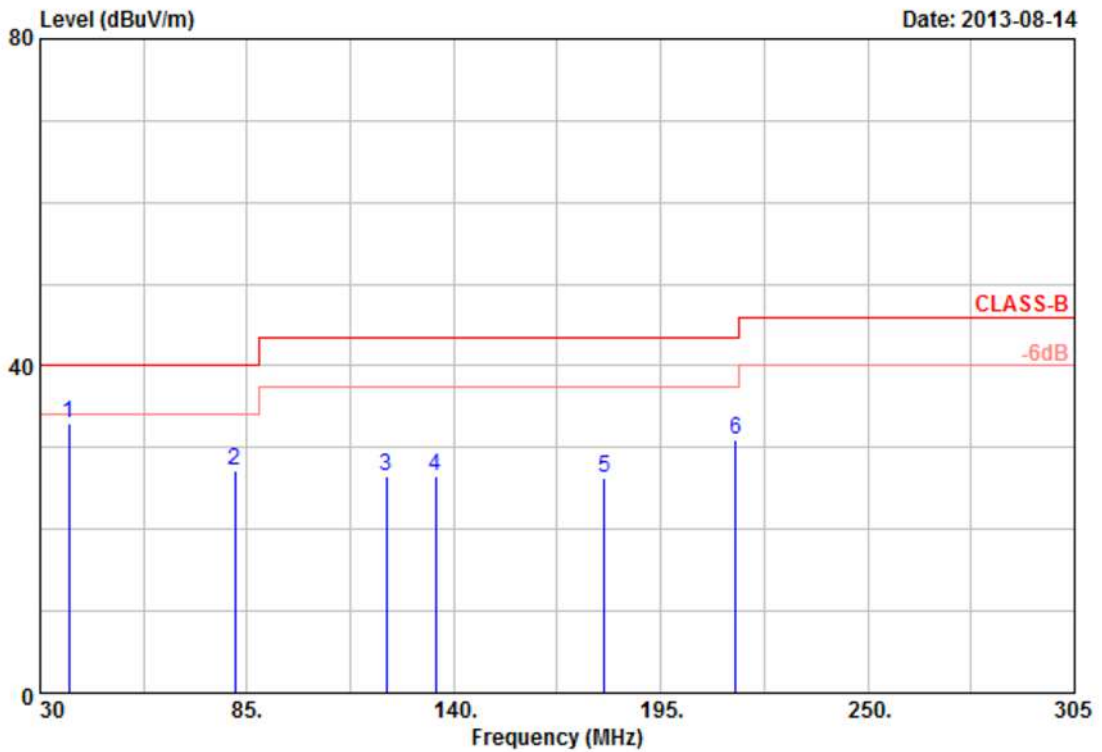

Item	Freq	Read Value	Factor	Result	Limit	Margin	Remark	Ant Pos	Tab Pos
	MHz	dBuV	dB/m	dBuV/m	dBuV/m	dB		cm	Deg
1	37.70	34.75	-1.78	32.97	40.00	-7.03	Peak	100	360
2	81.70	34.74	-7.52	27.22	40.00	-12.78	Peak	100	360
3	122.13	31.38	-4.76	26.62	43.50	-16.88	Peak	100	360
4	135.05	32.60	-6.14	26.46	43.50	-17.04	Peak	100	360
5	179.88	31.33	-5.06	26.27	43.50	-17.23	Peak	100	360
6	214.80	37.98	-6.99	30.99	43.50	-12.51	Peak	100	360

Remarks: 1. Result = Read Value + Factor
 2. Factor = Antenna Factor + Cable Loss - Amplifier
 3. According to technical experiences, all spurious emission of BT mode at channel 0,39,78 are almost the same below 1GHz, so that the channel 0 was chosen as representative in final test.
 4. The data is worst case.



Power	: DC 9V By Battery	Pol/Phase	: VERTICAL
Test Mode	: Transmit / Receive	Temperature	: 26 °C
Operation Channel	: 0	Humidity	: 48 %
Modulation Type	: $\pi/4$ -DQPSK (2 Mbps)	Atmospheric Pressure	: 1018 hPa

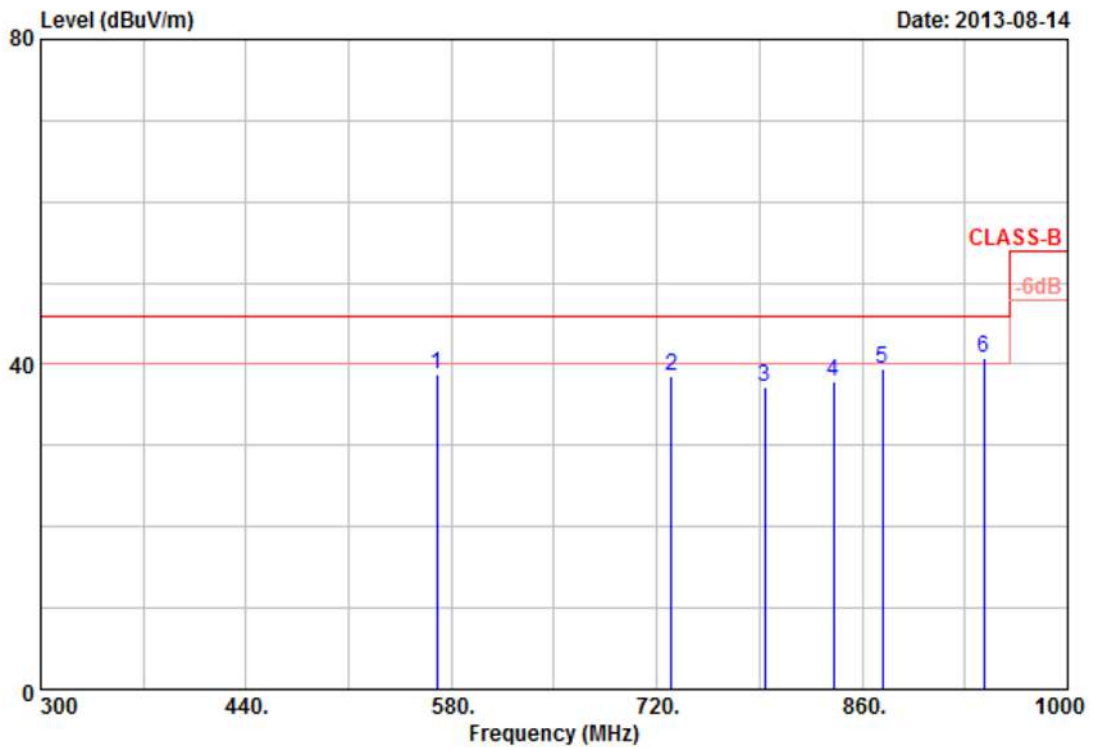

Item	Freq	Read Value	Factor	Result	Limit	Margin	Remark	Ant Pos	Tab Pos
	MHz	dBuV	dB/m	dBuV/m	dBuV/m	dB		cm	Deg
1	570.20	31.18	7.59	38.77	46.00	-7.23	Peak	100	0
2	729.80	31.33	7.17	38.50	46.00	-7.50	Peak	100	0
3	793.50	31.45	5.82	37.27	46.00	-8.73	Peak	100	0
4	840.40	28.72	9.17	37.89	46.00	-8.11	QP	100	0
5	874.00	30.06	9.47	39.53	46.00	-6.47	QP	100	0
6	942.60	29.40	11.30	40.70	46.00	-5.30	QP	100	0

- Remarks:
1. Result = Read Value + Factor
 2. Factor = Antenna Factor + Cable Loss - Amplifier
 3. According to technical experiences, all spurious emission of BT mode at channel 0,39,78 are almost the same below 1GHz, so that the channel 0 was chosen as representative in final test.
 4. The data is worst case.



Power	: DC 9V By Battery	Pol/Phase	: HORIZONTAL
Test Mode	: Transmit / Receive	Temperature	: 26 °C
Operation Channel	: 0	Humidity	: 48 %
Modulation Type	: $\pi/4$ -DQPSK (2 Mbps)	Atmospheric Pressure	: 1018 hPa

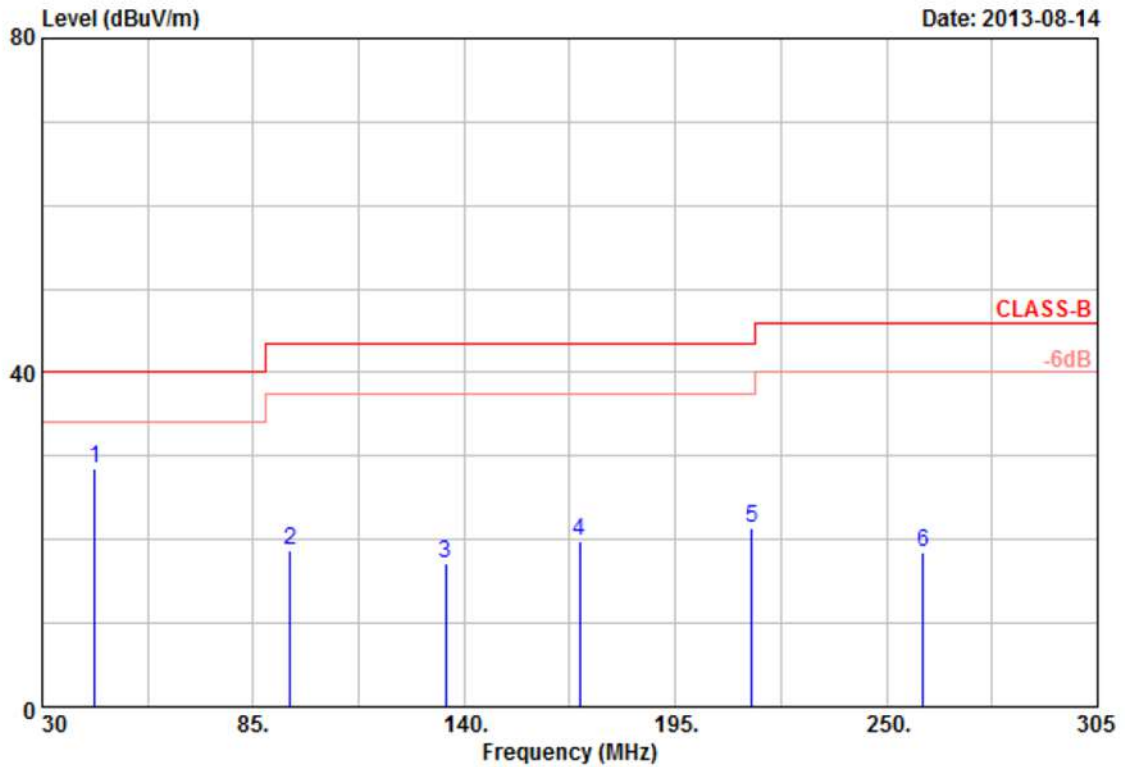

Item	Freq	Read Value	Factor	Result	Limit	Margin	Remark	Ant Pos	Tab Pos
	MHz	dBuV	dB/m	dBuV/m	dBuV/m	dB		cm	Deg
1	43.75	36.58	-8.03	28.55	40.00	-11.45	Peak	100	360
2	94.63	37.30	-18.54	18.76	43.50	-24.74	Peak	100	360
3	135.05	31.91	-14.68	17.23	43.50	-26.27	Peak	100	360
4	169.98	30.74	-10.97	19.77	43.50	-23.73	Peak	100	360
5	214.80	37.92	-16.46	21.46	43.50	-22.04	Peak	100	360
6	259.63	31.67	-13.27	18.40	46.00	-27.60	Peak	100	360

Remarks: 1. Result = Read Value + Factor
 2. Factor = Antenna Factor + Cable Loss - Amplifier
 3. According to technical experiences, all spurious emission of BT mode at channel 0,39,78 are almost the same below 1GHz, so that the channel 0 was chosen as representative in final test.
 4. The data is worst case.



Power	: DC 9V By Battery	Pol/Phase	: HORIZONTAL
Test Mode	: Transmit / Receive	Temperature	: 26 °C
Operation Channel	: 0	Humidity	: 48 %
Modulation Type	: $\pi/4$ -DQPSK (2 Mbps)	Atmospheric Pressure	: 1018 hPa

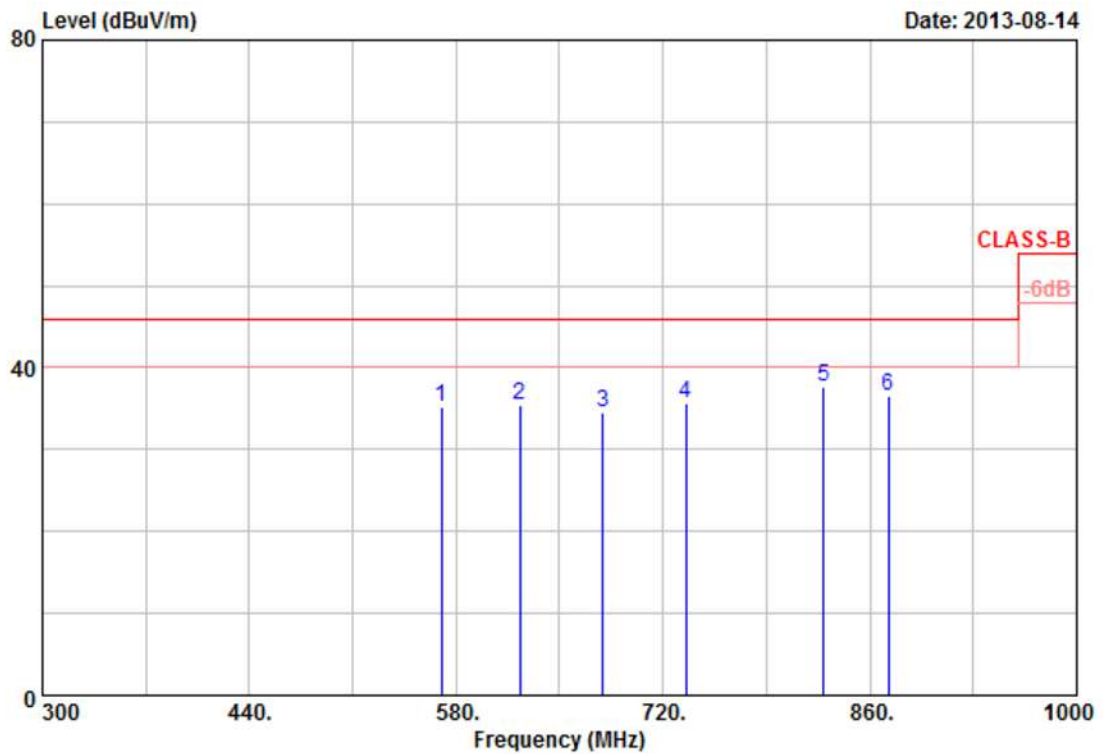

Item	Freq	Read Value	Factor	Result	Limit	Margin	Remark	Ant Pos	Tab Pos
	MHz	dBuV	dB/m	dBuV/m	dBuV/m	dB		cm	Deg
1	570.20	31.86	3.42	35.28	46.00	-10.72	Peak	100	0
2	623.40	31.24	4.21	35.45	46.00	-10.55	Peak	100	0
3	679.40	32.04	2.40	34.44	46.00	-11.56	Peak	100	0
4	735.40	31.88	3.83	35.71	46.00	-10.29	Peak	100	0
5	828.50	29.24	8.34	37.58	46.00	-8.42	QP	100	0
6	872.60	31.70	4.81	36.51	46.00	-9.49	QP	100	0

Remarks: 1. Result = Read Value + Factor
 2. Factor = Antenna Factor + Cable Loss - Amplifier
 3. According to technical experiences, all spurious emission of BT mode at channel 0,39,78 are almost the same below 1GHz, so that the channel 0 was chosen as representative in final test.
 4. The data is worst case.



Power	: DC 9V By Battery	Pol/Phase	: VERTICAL
Test Mode	: Transmit / Receive	Temperature	: 26 °C
Operation Channel	: 0	Humidity	: 48 %
Modulation Type	: 8DPSK (3 Mbps)	Atmospheric Pressure	: 1018 hPa

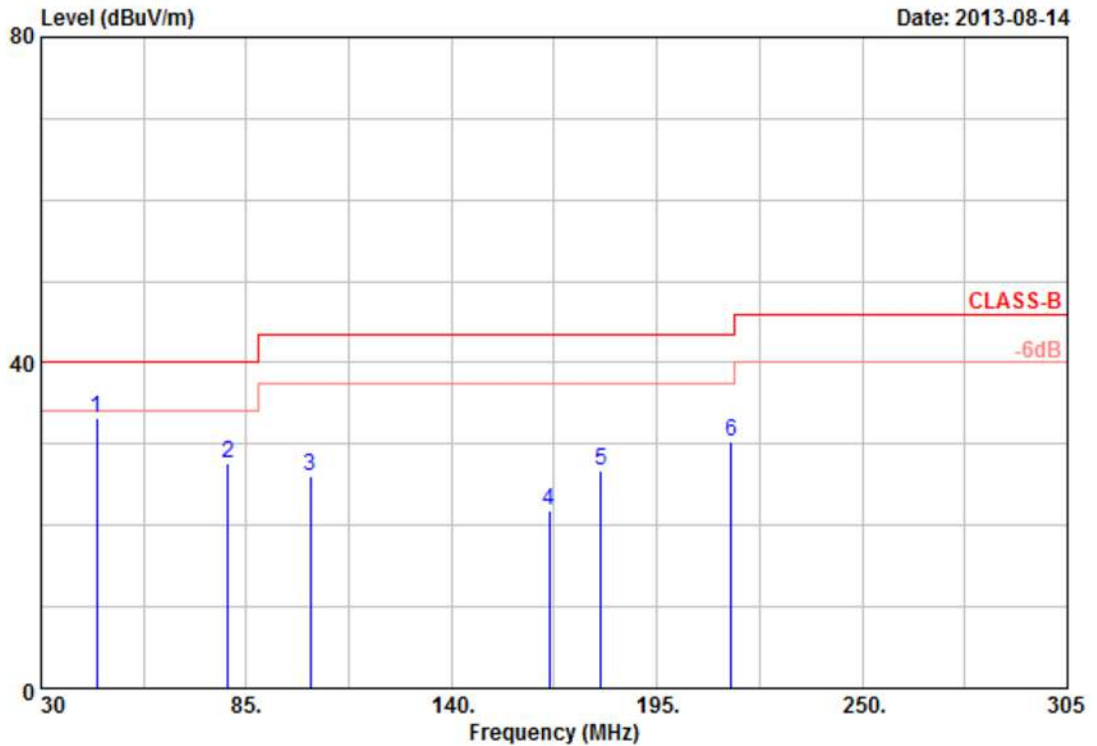

Item	Freq	Read Value	Factor	Result	Limit	Margin	Remark	Ant Pos	Tab Pos
	MHz	dBuV	dB/m	dBuV/m	dBuV/m	dB		cm	Deg
1	44.85	34.42	-1.11	33.31	40.00	-6.69	Peak	100	360
2	80.05	35.11	-7.44	27.67	40.00	-12.33	Peak	100	360
3	102.05	34.55	-8.39	26.16	43.50	-17.34	Peak	100	360
4	166.13	32.23	-10.34	21.89	43.50	-21.61	Peak	100	360
5	179.88	31.82	-5.06	26.76	43.50	-16.74	Peak	100	360
6	214.80	37.25	-6.99	30.26	43.50	-13.24	Peak	100	360

Remarks: 1. Result = Read Value + Factor
 2. Factor = Antenna Factor + Cable Loss - Amplifier
 3. According to technical experiences, all spurious emission of BT mode at channel 0,39,78 are almost the same below 1GHz, so that the channel 0 was chosen as representative in final test.
 4. The data is worst case.



Power	: DC 9V By Battery	Pol/Phase	: VERTICAL
Test Mode	: Transmit / Receive	Temperature	: 26 °C
Operation Channel	: 0	Humidity	: 48 %
Modulation Type	: 8DPSK (3 Mbps)	Atmospheric Pressure	: 1018 hPa

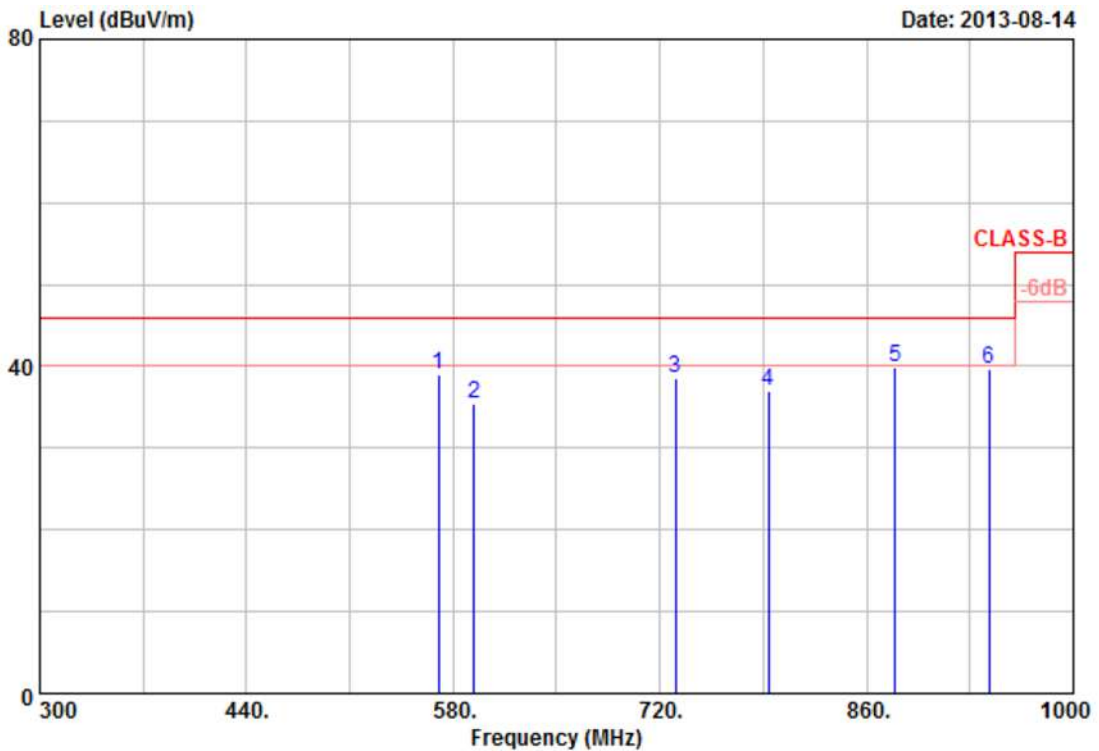

Item	Freq	Read Value	Factor	Result	Limit	Margin	Remark	Ant Pos	Tab Pos
	MHz	dBuV	dB/m	dBuV/m	dBuV/m	dB		cm	Deg
1	570.20	31.46	7.59	39.05	46.00	-6.95	Peak	100	0
2	594.00	31.72	3.62	35.34	46.00	-10.66	Peak	100	0
3	730.50	31.27	7.18	38.45	46.00	-7.55	Peak	100	0
4	793.50	31.08	5.82	36.90	46.00	-9.10	Peak	100	0
5	879.60	29.77	10.07	39.84	46.00	-6.16	QP	100	0
6	942.60	28.47	11.30	39.77	46.00	-6.23	QP	100	0

Remarks: 1. Result = Read Value + Factor
 2. Factor = Antenna Factor + Cable Loss - Amplifier
 3. According to technical experiences, all spurious emission of BT mode at channel 0,39,78 are almost the same below 1GHz, so that the channel 0 was chosen as representative in final test.
 4. The data is worst case.



Power	: DC 9V By Battery	Pol/Phase	: HORIZONTAL
Test Mode	: Transmit / Receive	Temperature	: 26 °C
Operation Channel	: 0	Humidity	: 48 %
Modulation Type	: 8DPSK (3 Mbps)	Atmospheric Pressure	: 1018 hPa

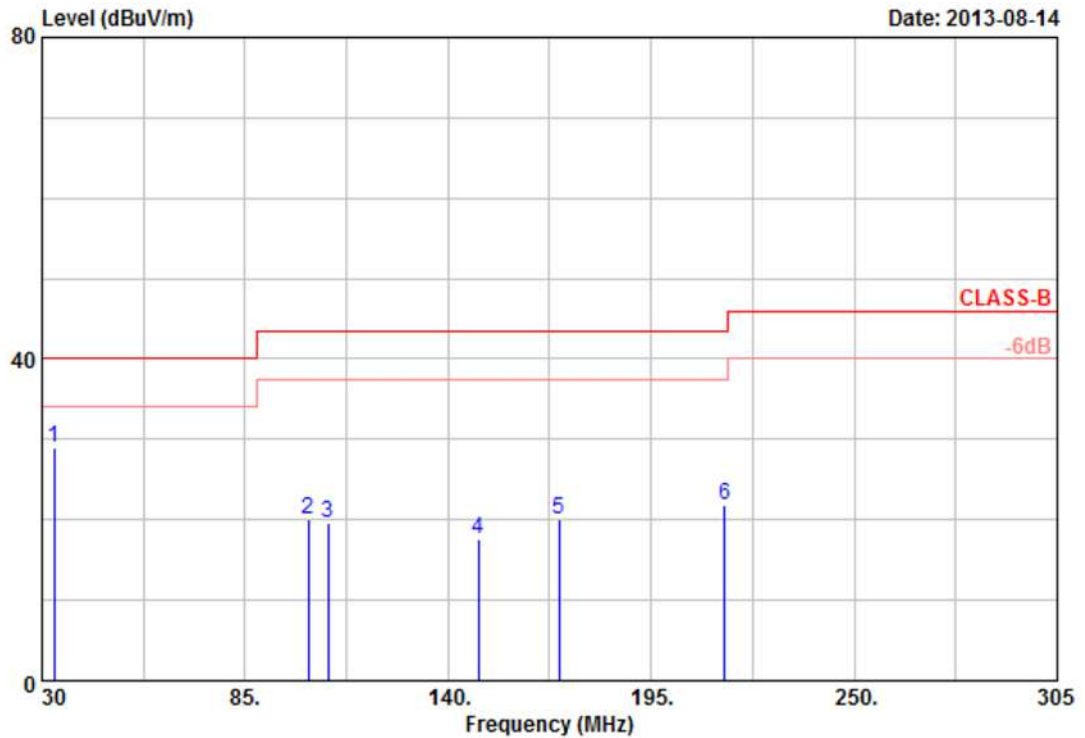

Item	Freq	Read Value	Factor	Result	Limit	Margin	Remark	Ant Pos	Tab Pos
	MHz	dBuV	dB/m	dBuV/m	dBuV/m	dB		cm	Deg
1	33.30	35.30	-6.33	28.97	40.00	-11.03	Peak	100	360
2	102.05	38.87	-18.73	20.14	43.50	-23.36	Peak	100	360
3	107.55	38.57	-18.88	19.69	43.50	-23.81	Peak	100	360
4	148.25	32.30	-14.69	17.61	43.50	-25.89	Peak	100	360
5	169.98	31.02	-10.97	20.05	43.50	-23.45	Peak	100	360
6	214.80	38.36	-16.46	21.90	43.50	-21.60	Peak	100	360

Remarks: 1. Result = Read Value + Factor
 2. Factor = Antenna Factor + Cable Loss - Amplifier
 3. According to technical experiences, all spurious emission of BT mode at channel 0,39,78 are almost the same below 1GHz, so that the channel 0 was chosen as representative in final test.
 4. The data is worst case.



Power	: DC 9V By Battery	Pol/Phase	: HORIZONTAL
Test Mode	: Transmit / Receive	Temperature	: 26 °C
Operation Channel	: 0	Humidity	: 48 %
Modulation Type	: 8DPSK (3 Mbps)	Atmospheric Pressure	: 1018 hPa

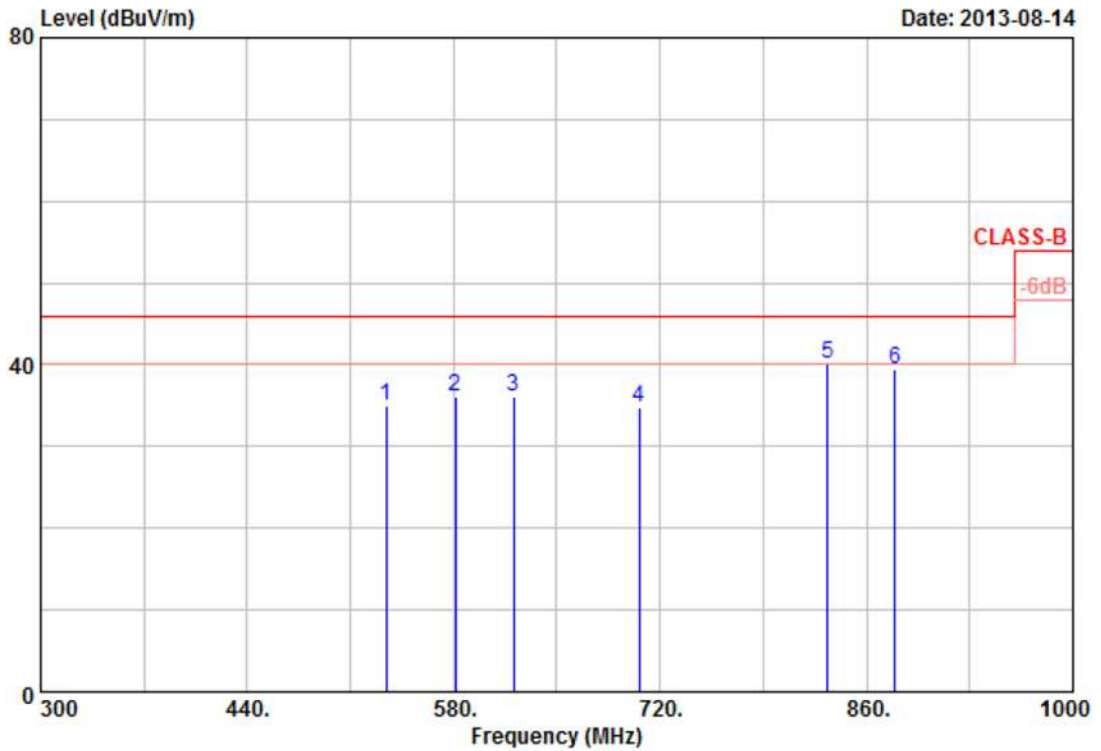

Item	Freq	Read Value	Factor	Result	Limit	Margin	Remark	Ant Pos	Tab Pos
	MHz	dBuV	dB/m	dBuV/m	dBuV/m	dB		cm	Deg
1	534.50	32.46	2.43	34.89	46.00	-11.11	Peak	100	0
2	581.40	33.60	2.47	36.07	46.00	-9.93	Peak	100	0
3	620.60	31.99	4.06	36.05	46.00	-9.95	Peak	100	0
4	706.00	32.30	2.36	34.66	46.00	-11.34	Peak	100	0
5	833.40	31.24	8.80	40.04	46.00	-5.96	Peak	100	0
6	879.60	33.77	5.59	39.36	46.00	-6.64	Peak	100	0

Remarks: 1. Result = Read Value + Factor
 2. Factor = Antenna Factor + Cable Loss - Amplifier
 3. According to technical experiences, all spurious emission of BT mode at channel 0,39,78 are almost the same below 1GHz, so that the channel 0 was chosen as representative in final test.
 4. The data is worst case.



5.7 Test Result and Data (1GHz ~ 25GHz)

Power	: DC 9V By Battery	Pol/Phase	: VERTICAL
Test Mode	: Transmit / Receive	Temperature	: 25 °C
Operation Channel	: 0	Humidity	: 46 %
Modulation Type	: GFSK (1Mbps)	Atmospheric Pressure	: 1017 hPa

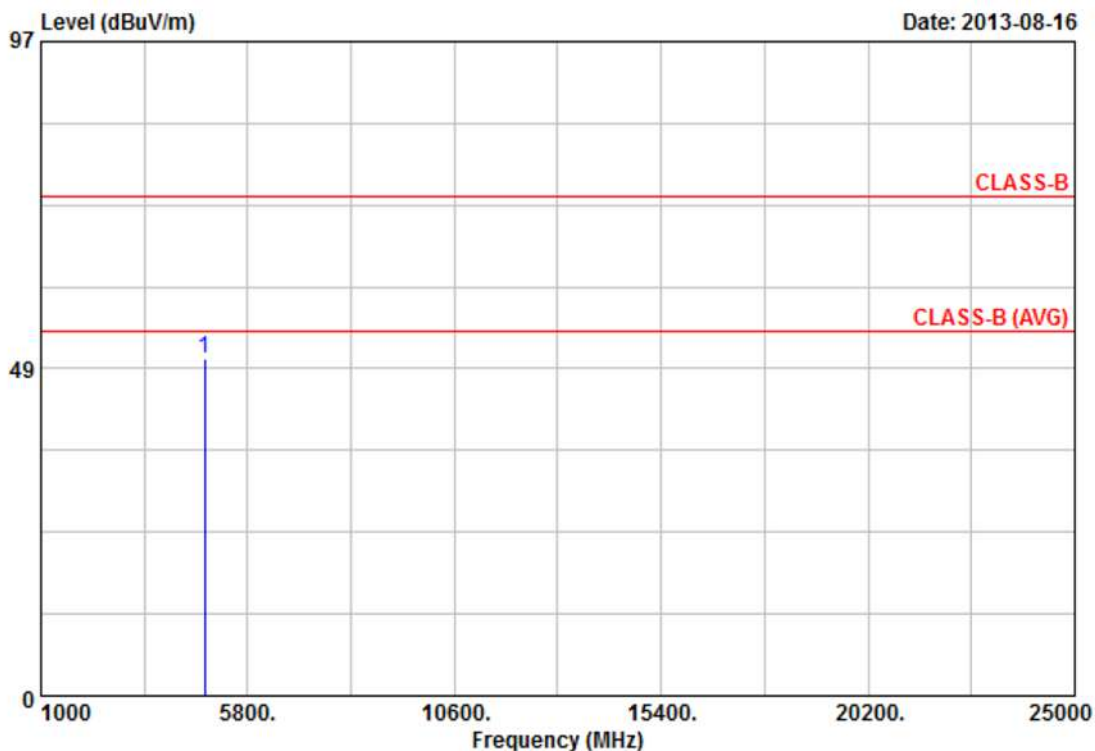

Item	Freq	Read Value	Factor	Result	Limit	Margin	Remark	Ant Pos	Tab Pos
	MHz	dBuV	dB/m	dBuV/m	dBuV/m	dB		cm	Deg
1	4804.00	44.71	5.27	49.98	74.00	-24.02	Peak	100	360

Notes:

1. Result = Read Value + Factor
2. Factor = Antenna Factor + Cable Loss - Amplifier
3. The resolution bandwidth of test receiver/spectrum analyzer is 120KHz and video bandwidth is 300kHz for Peak detection and Quasi-peak detection at frequency below 1GHz.
4. The resolution bandwidth of test receiver/spectrum analyzer is 1MHz and video bandwidth is 3MHz for Peak detection at frequency above 1GHz.
5. The resolution bandwidth of test receiver/spectrum analyzer is 1MHz and video bandwidth is 10Hz for Average detection at frequency above 1GHz.
6. The other emissions is too low to be measured.
7. The data is worse case.



Power	: DC 9V By Battery	Pol/Phase	: HORIZONTAL
Test Mode	: Transmit / Receive	Temperature	: 25 °C
Operation Channel	: 0	Humidity	: 46 %
Modulation Type	: GFSK (1Mbps)	Atmospheric Pressure	: 1017 hPa

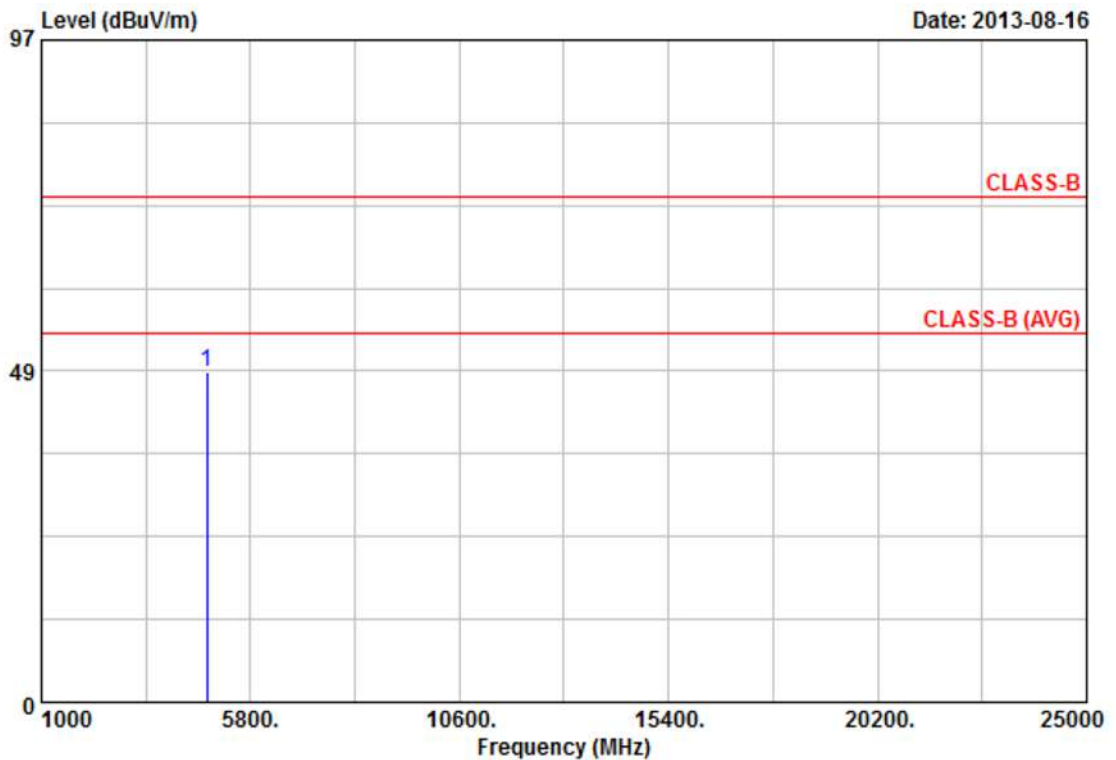

Item	Freq	Read Value	Factor	Result	Limit	Margin	Remark	Ant Pos	Tab Pos
	MHz	dBuV	dB/m	dBuV/m	dBuV/m	dB		cm	Deg
1	4804.00	44.75	3.69	48.44	74.00	-25.56	Peak	100	0

Notes:

1. Result = Read Value + Factor
2. Factor = Antenna Factor + Cable Loss - Amplifier
3. The resolution bandwidth of test receiver/spectrum analyzer is 120KHz and video bandwidth is 300kHz for Peak detection and Quasi-peak detection at frequency below 1GHz.
4. The resolution bandwidth of test receiver/spectrum analyzer is 1MHz and video bandwidth is 3MHz for Peak detection at frequency above 1GHz.
5. The resolution bandwidth of test receiver/spectrum analyzer is 1MHz and video bandwidth is 10Hz for Average detection at frequency above 1GHz.
6. The other emissions is too low to be measured.
7. The data is worse case.



Power	: DC 9V By Battery	Pol/Phase	: VERTICAL
Test Mode	: Transmit / Receive	Temperature	: 25 °C
Operation Channel	: 39	Humidity	: 46 %
Modulation Type	: GFSK (1Mbps)	Atmospheric Pressure	: 1017 hPa

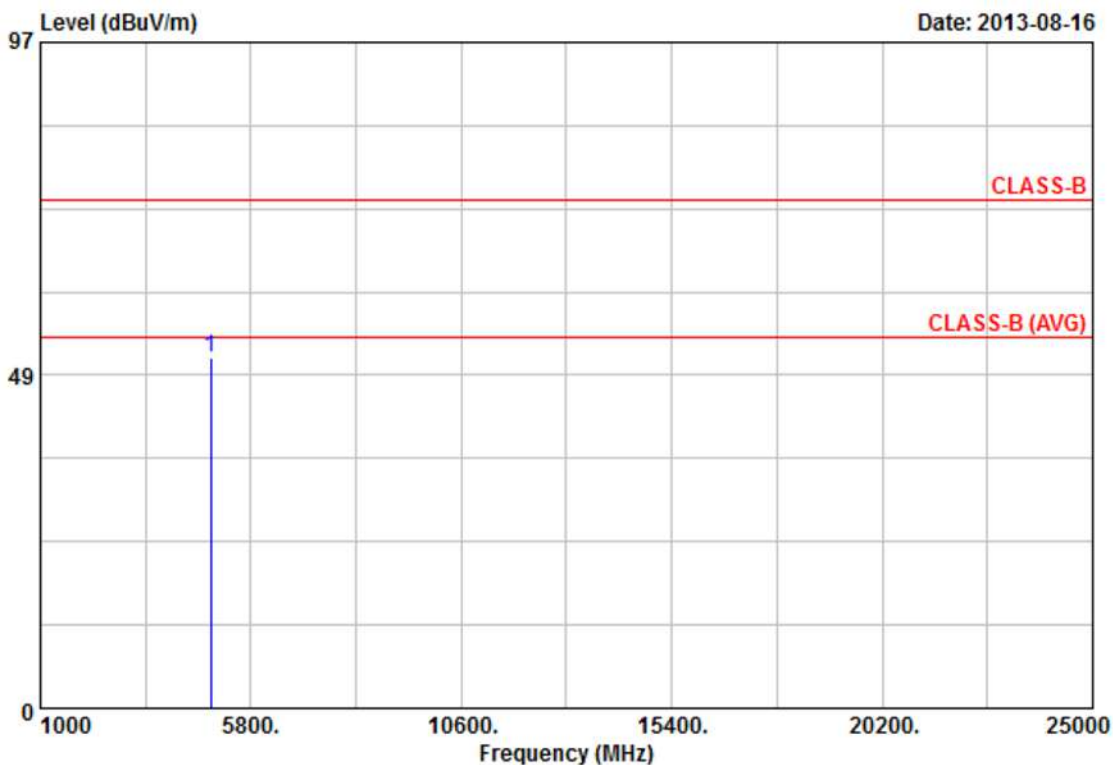

Item	Freq	Read Value	Factor	Result	Limit	Margin	Remark	Ant Pos	Tab Pos
	MHz	dBuV	dB/m	dBuV/m	dBuV/m	dB		cm	Deg
1	4882.00	44.35	6.81	51.16	74.00	-22.84	Peak	100	360

Notes:

1. Result = Read Value + Factor
2. Factor = Antenna Factor + Cable Loss - Amplifier
3. The resolution bandwidth of test receiver/spectrum analyzer is 120KHz and video bandwidth is 300kHz for Peak detection and Quasi-peak detection at frequency below 1GHz.
4. The resolution bandwidth of test receiver/spectrum analyzer is 1MHz and video bandwidth is 3MHz for Peak detection at frequency above 1GHz.
5. The resolution bandwidth of test receiver/spectrum analyzer is 1MHz and video bandwidth is 10Hz for Average detection at frequency above 1GHz.
6. The other emissions is too low to be measured.
7. The data is worse case.



Power	: DC 9V By Battery	Pol/Phase	: HORIZONTAL
Test Mode	: Transmit / Receive	Temperature	: 25 °C
Operation Channel	: 39	Humidity	: 46 %
Modulation Type	: GFSK (1Mbps)	Atmospheric Pressure	: 1017 hPa

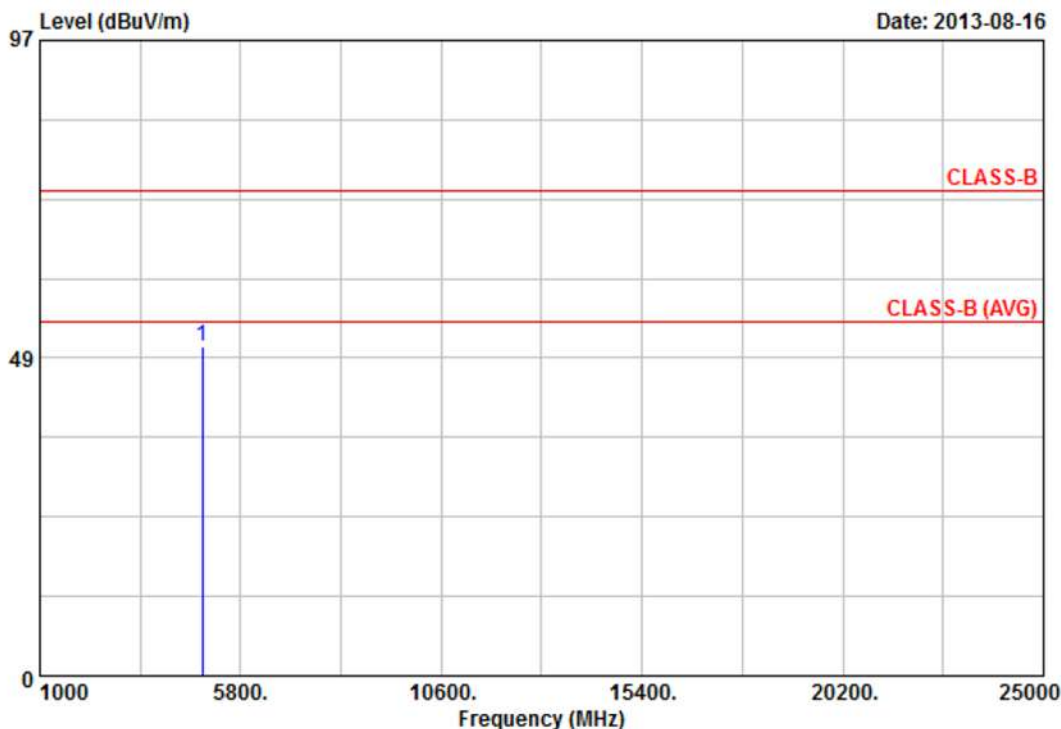

Item	Freq	Read Value	Factor	Result	Limit	Margin	Remark	Ant Pos	Tab Pos
	MHz	dBuV	dB/m	dBuV/m	dBuV/m	dB		cm	Deg
1	4882.00	45.35	4.92	50.27	74.00	-23.73	Peak	100	0

Notes:

1. Result = Read Value + Factor
2. Factor = Antenna Factor + Cable Loss - Amplifier
3. The resolution bandwidth of test receiver/spectrum analyzer is 120KHz and video bandwidth is 300KHz for Peak detection and Quasi-peak detection at frequency below 1GHz.
4. The resolution bandwidth of test receiver/spectrum analyzer is 1MHz and video bandwidth is 3MHz for Peak detection at frequency above 1GHz.
5. The resolution bandwidth of test receiver/spectrum analyzer is 1MHz and video bandwidth is 10Hz for Average detection at frequency above 1GHz.
6. The other emissions is too low to be measured.
7. The data is worse case.



Power	: DC 9V By Battery	Pol/Phase	: VERTICAL
Test Mode	: Transmit / Receive	Temperature	: 25 °C
Operation Channel	: 78	Humidity	: 46 %
Modulation Type	: GFSK (1Mbps)	Atmospheric Pressure	: 1017 hPa

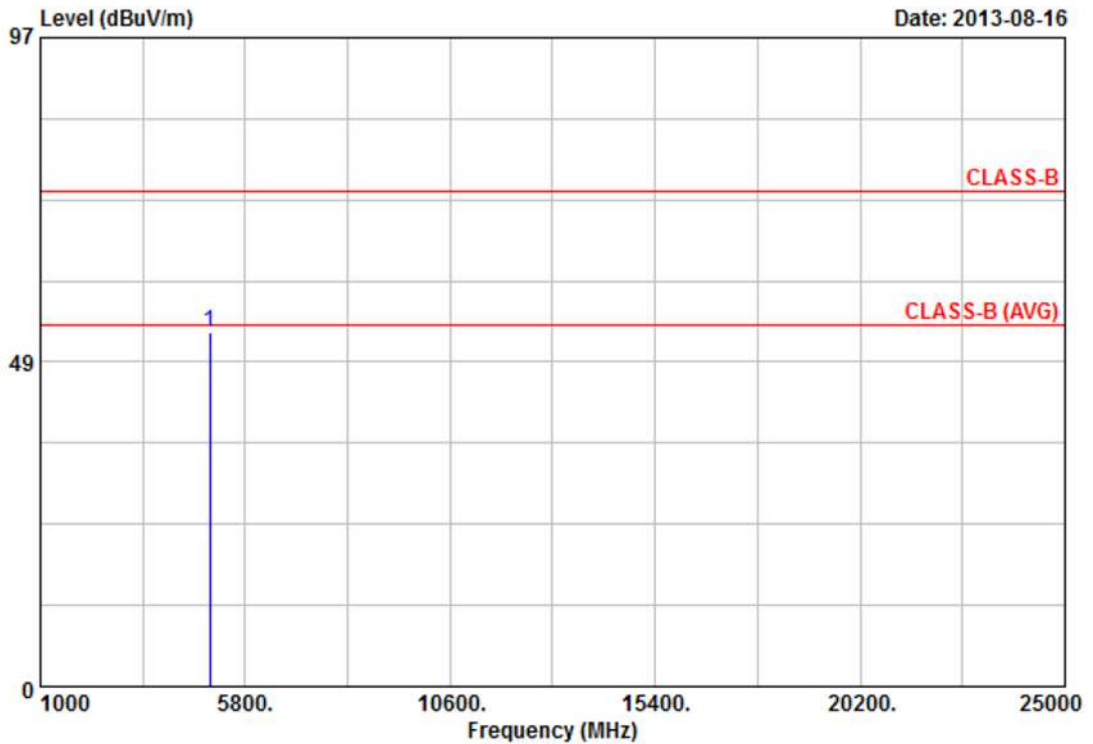

Item	Freq	Read Value	Factor	Result	Limit	Margin	Remark	Ant Pos	Tab Pos
	MHz	dBuV	dB/m	dBuV/m	dBuV/m	dB		cm	Deg
1	4960.00	45.65	7.32	52.97	74.00	-21.03	Peak	100	360

Notes:

1. Result = Read Value + Factor
2. Factor = Antenna Factor + Cable Loss - Amplifier
3. The resolution bandwidth of test receiver/spectrum analyzer is 120kHz and video bandwidth is 300kHz for Peak detection and Quasi-peak detection at frequency below 1GHz.
4. The resolution bandwidth of test receiver/spectrum analyzer is 1MHz and video bandwidth is 3MHz for Peak detection at frequency above 1GHz.
5. The resolution bandwidth of test receiver/spectrum analyzer is 1MHz and video bandwidth is 10Hz for Average detection at frequency above 1GHz.
6. The other emissions is too low to be measured.
7. The data is worse case.



Power	: DC 9V By Battery	Pol/Phase	: HORIZONTAL
Test Mode	: Transmit / Receive	Temperature	: 25 °C
Operation Channel	: 78	Humidity	: 46 %
Modulation Type	: GFSK (1Mbps)	Atmospheric Pressure	: 1017 hPa

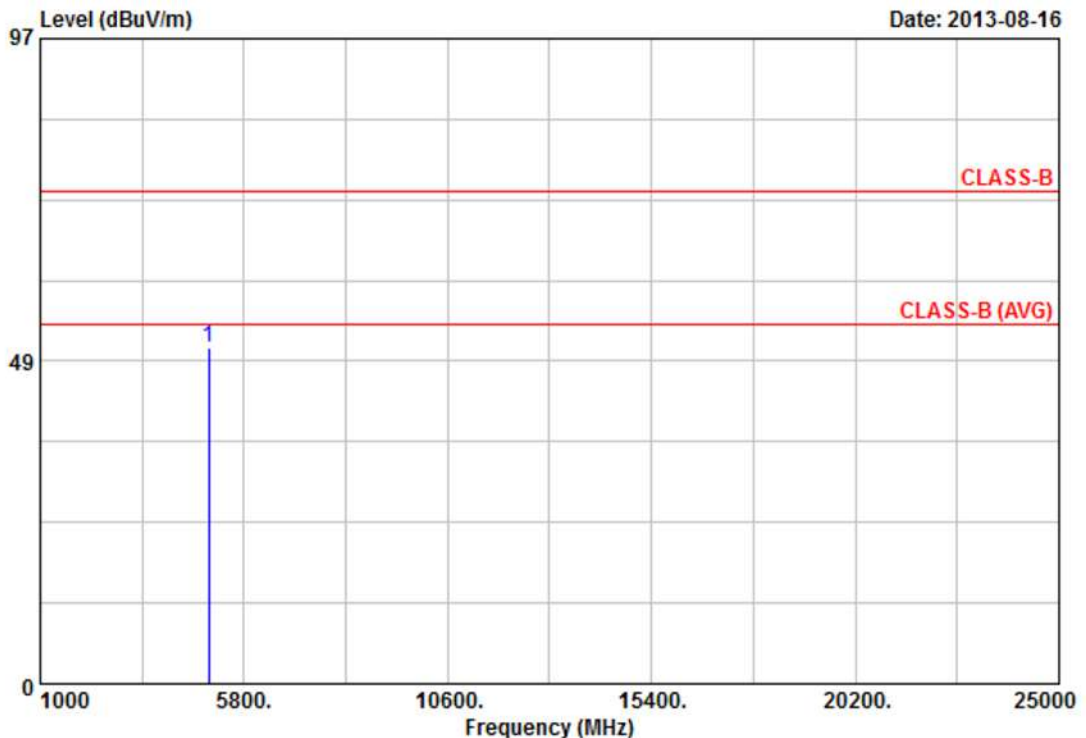

Item	Freq	Read Value	Factor	Result	Limit	Margin	Remark	Ant Pos	Tab Pos
	MHz	dBuV	dB/m	dBuV/m	dBuV/m	dB		cm	Deg
1	4960.00	45.36	5.22	50.58	74.00	-23.42	Peak	100	0

Notes:

1. Result = Read Value + Factor
2. Factor = Antenna Factor + Cable Loss - Amplifier
3. The resolution bandwidth of test receiver/spectrum analyzer is 120KHz and video bandwidth is 300kHz for Peak detection and Quasi-peak detection at frequency below 1GHz.
4. The resolution bandwidth of test receiver/spectrum analyzer is 1MHz and video bandwidth is 3MHz for Peak detection at frequency above 1GHz.
5. The resolution bandwidth of test receiver/spectrum analyzer is 1MHz and video bandwidth is 10Hz for Average detection at frequency above 1GHz.
6. The other emissions is too low to be measured.
7. The data is worse case.



Power	: DC 9V By Battery	Pol/Phase	: VERTICAL
Test Mode	: Transmit / Receive	Temperature	: 25 °C
Operation Channel	: 0	Humidity	: 46 %
Modulation Type	: $\pi/4$ -DQPSK (2 Mbps)	Atmospheric Pressure	: 1017 hPa

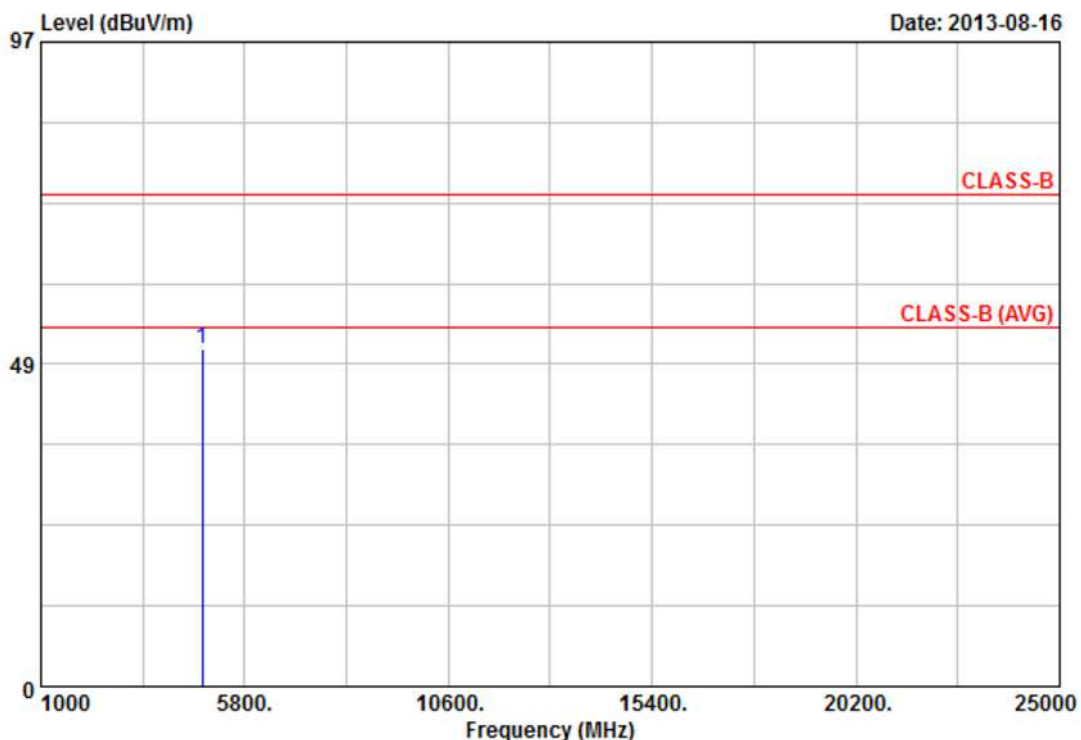

Item	Freq	Read Value	Factor	Result	Limit	Margin	Remark	Ant Pos	Tab Pos
	MHz	dBuV	dB/m	dBuV/m	dBuV/m	dB		cm	Deg
1	4804.00	45.47	5.27	50.74	74.00	-23.26	Peak	100	360

Notes:

1. Result = Read Value + Factor
2. Factor = Antenna Factor + Cable Loss - Amplifier
3. The resolution bandwidth of test receiver/spectrum analyzer is 120KHz and video bandwidth is 300KHz for Peak detection and Quasi-peak detection at frequency below 1GHz.
4. The resolution bandwidth of test receiver/spectrum analyzer is 1MHz and video bandwidth is 3MHz for Peak detection at frequency above 1GHz.
5. The resolution bandwidth of test receiver/spectrum analyzer is 1MHz and video bandwidth is 10Hz for Average detection at frequency above 1GHz.
6. The other emissions is too low to be measured.
7. The data is worse case.



Power	: DC 9V By Battery	Pol/Phase	: HORIZONTAL
Test Mode	: Transmit / Receive	Temperature	: 25 °C
Operation Channel	: 0	Humidity	: 46 %
Modulation Type	: $\pi/4$ -DQPSK (2 Mbps)	Atmospheric Pressure	: 1017 hPa

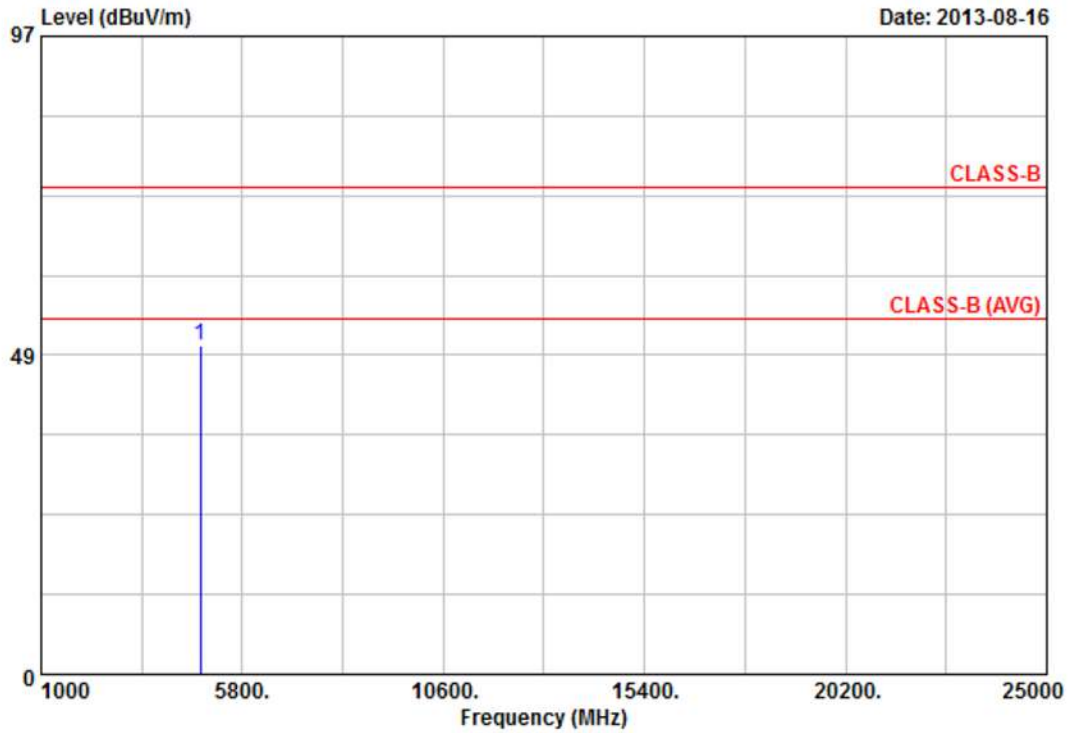

Item	Freq	Read Value	Factor	Result	Limit	Margin	Remark	Ant Pos	Tab Pos
	MHz	dBuV	dB/m	dBuV/m	dBuV/m	dB		cm	Deg
1	4804.00	46.33	3.69	50.02	74.00	-23.98	Peak	100	0

Notes:

1. Result = Read Value + Factor
2. Factor = Antenna Factor + Cable Loss - Amplifier
3. The resolution bandwidth of test receiver/spectrum analyzer is 120KHz and video bandwidth is 300kHz for Peak detection and Quasi-peak detection at frequency below 1GHz.
4. The resolution bandwidth of test receiver/spectrum analyzer is 1MHz and video bandwidth is 3MHz for Peak detection at frequency above 1GHz.
5. The resolution bandwidth of test receiver/spectrum analyzer is 1MHz and video bandwidth is 10Hz for Average detection at frequency above 1GHz.
6. The other emissions is too low to be measured.
7. The data is worse case.



Power	: DC 9V By Battery	Pol/Phase	: VERTICAL
Test Mode	: Transmit / Receive	Temperature	: 25 °C
Operation Channel	: 39	Humidity	: 46 %
Modulation Type	: $\pi/4$ -DQPSK (2 Mbps)	Atmospheric Pressure	: 1017 hPa

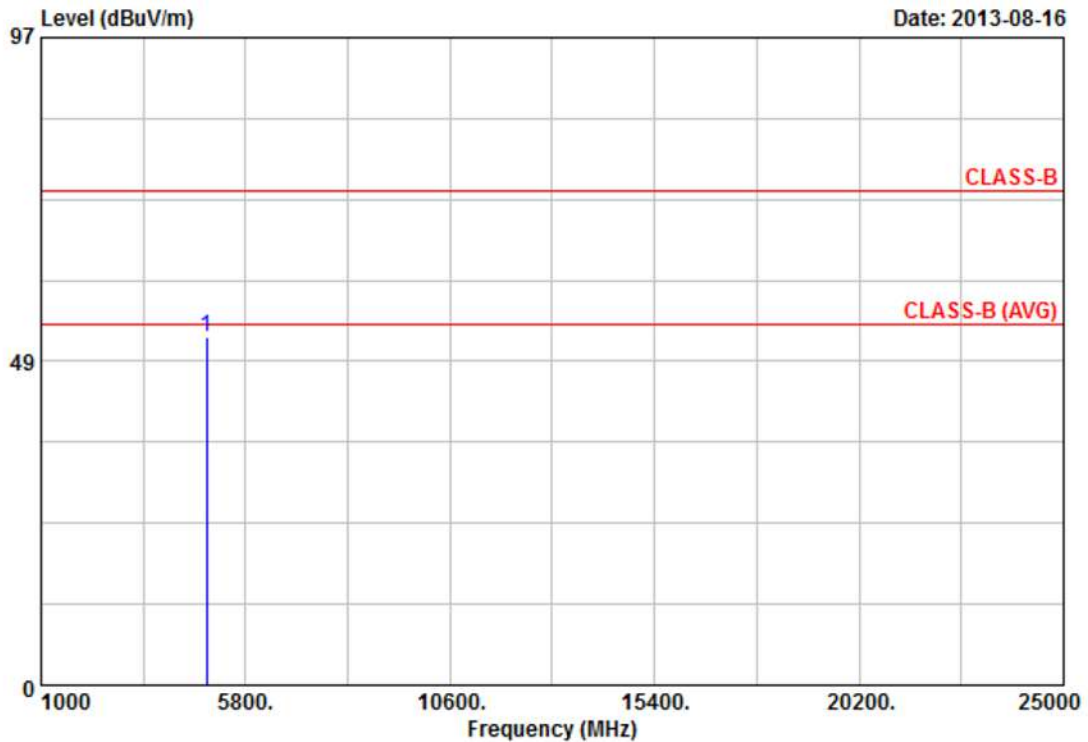

Item	Freq	Read Value	Factor	Result	Limit	Margin	Remark	Ant Pos	Tab Pos
	MHz	dBuV	dB/m	dBuV/m	dBuV/m	dB		cm	Deg
1	4882.00	45.45	6.81	52.26	74.00	-21.74	Peak	100	360

Notes:

1. Result = Read Value + Factor
2. Factor = Antenna Factor + Cable Loss - Amplifier
3. The resolution bandwidth of test receiver/spectrum analyzer is 120KHz and video bandwidth is 300kHz for Peak detection and Quasi-peak detection at frequency below 1GHz.
4. The resolution bandwidth of test receiver/spectrum analyzer is 1MHz and video bandwidth is 3MHz for Peak detection at frequency above 1GHz.
5. The resolution bandwidth of test receiver/spectrum analyzer is 1MHz and video bandwidth is 10Hz for Average detection at frequency above 1GHz.
6. The other emissions is too low to be measured.
7. The data is worse case.



Power	: DC 9V By Battery	Pol/Phase	: HORIZONTAL
Test Mode	: Transmit / Receive	Temperature	: 25 °C
Operation Channel	: 39	Humidity	: 46 %
Modulation Type	: $\pi/4$ -DQPSK (2 Mbps)	Atmospheric Pressure	: 1017 hPa

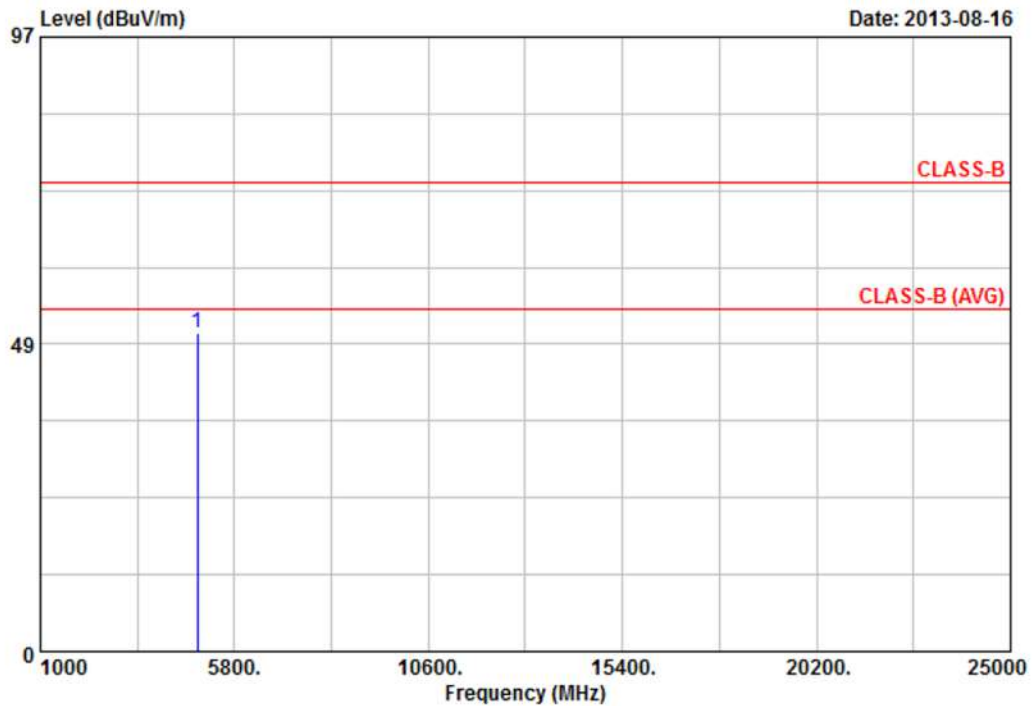

Item	Freq	Read Value	Factor	Result	Limit	Margin	Remark	Ant Pos	Tab Pos
	MHz	dBuV	dB/m	dBuV/m	dBuV/m	dB		cm	Deg
1	4882.00	45.32	4.92	50.24	74.00	-23.76	Peak	100	0

Notes:

1. Result = Read Value + Factor
2. Factor = Antenna Factor + Cable Loss - Amplifier
3. The resolution bandwidth of test receiver/spectrum analyzer is 120KHz and video bandwidth is 300kHz for Peak detection and Quasi-peak detection at frequency below 1GHz.
4. The resolution bandwidth of test receiver/spectrum analyzer is 1MHz and video bandwidth is 3MHz for Peak detection at frequency above 1GHz.
5. The resolution bandwidth of test receiver/spectrum analyzer is 1MHz and video bandwidth is 10Hz for Average detection at frequency above 1GHz.
6. The other emissions is too low to be measured.
7. The data is worse case.



Power	: DC 9V By Battery	Pol/Phase	: VERTICAL
Test Mode	: Transmit / Receive	Temperature	: 25 °C
Operation Channel	: 78	Humidity	: 46 %
Modulation Type	: $\pi/4$ -DQPSK (2 Mbps)	Atmospheric Pressure	: 1017 hPa

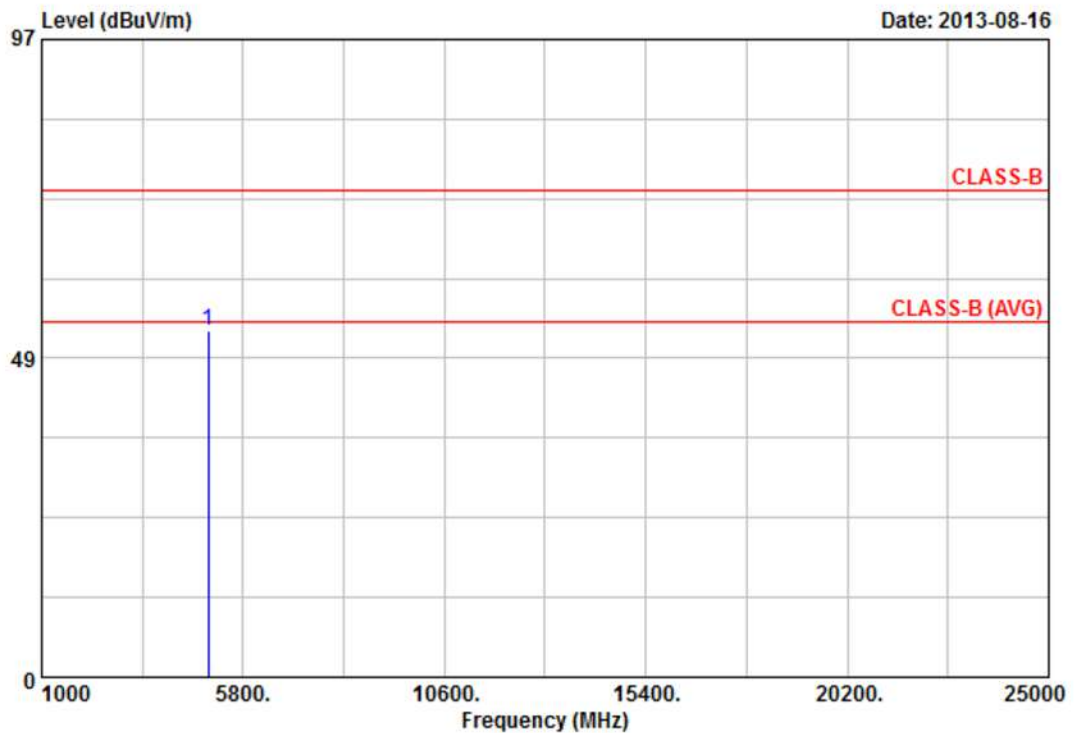

Item	Freq	Read Value	Factor	Result	Limit	Margin	Remark	Ant Pos	Tab Pos
	MHz	dBuV	dB/m	dBuV/m	dBuV/m	dB		cm	Deg
1	4960.00	45.32	7.32	52.64	74.00	-21.36	Peak	100	360

Notes:

1. Result = Read Value + Factor
2. Factor = Antenna Factor + Cable Loss - Amplifier
3. The resolution bandwidth of test receiver/spectrum analyzer is 120KHz and video bandwidth is 300kHz for Peak detection and Quasi-peak detection at frequency below 1GHz.
4. The resolution bandwidth of test receiver/spectrum analyzer is 1MHz and video bandwidth is 3MHz for Peak detection at frequency above 1GHz.
5. The resolution bandwidth of test receiver/spectrum analyzer is 1MHz and video bandwidth is 10Hz for Average detection at frequency above 1GHz.
6. The other emissions is too low to be measured.
7. The data is worse case.



Power	: DC 9V By Battery	Pol/Phase	: HORIZONTAL
Test Mode	: Transmit / Receive	Temperature	: 25 °C
Operation Channel	: 78	Humidity	: 46 %
Modulation Type	: $\pi/4$ -DQPSK (2 Mbps)	Atmospheric Pressure	: 1017 hPa

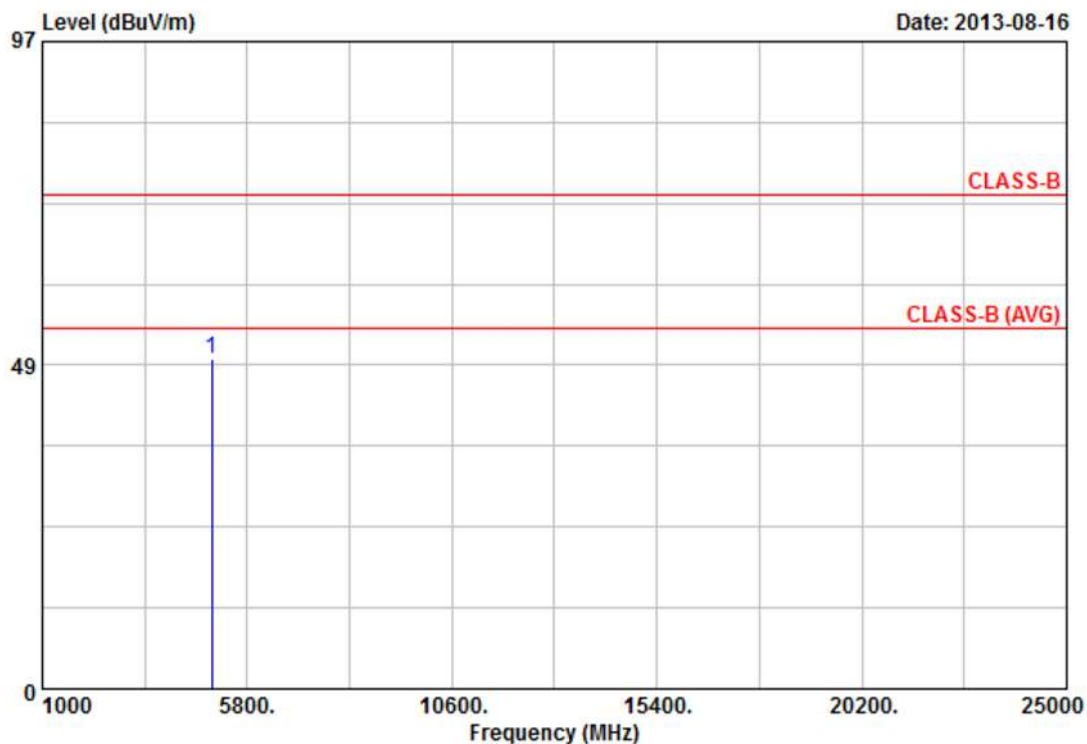

Item	Freq	Read Value	Factor	Result	Limit	Margin	Remark	Ant Pos	Tab Pos
	MHz	dBuV	dB/m	dBuV/m	dBuV/m	dB		cm	Deg
1	4960.00	44.26	5.22	49.48	74.00	-24.52	Peak	100	0

Notes:

1. Result = Read Value + Factor
2. Factor = Antenna Factor + Cable Loss - Amplifier
3. The resolution bandwidth of test receiver/spectrum analyzer is 120KHz and video bandwidth is 300kHz for Peak detection and Quasi-peak detection at frequency below 1GHz.
4. The resolution bandwidth of test receiver/spectrum analyzer is 1MHz and video bandwidth is 3MHz for Peak detection at frequency above 1GHz.
5. The resolution bandwidth of test receiver/spectrum analyzer is 1MHz and video bandwidth is 10Hz for Average detection at frequency above 1GHz.
6. The other emissions is too low to be measured.
7. The data is worse case.



Power	: DC 9V By Battery	Pol/Phase	: VERTICAL
Test Mode	: Transmit / Receive	Temperature	: 25 °C
Operation Channel	: 0	Humidity	: 46 %
Modulation Type	: 8DPSK (3 Mbps)	Atmospheric Pressure	: 1017 hPa

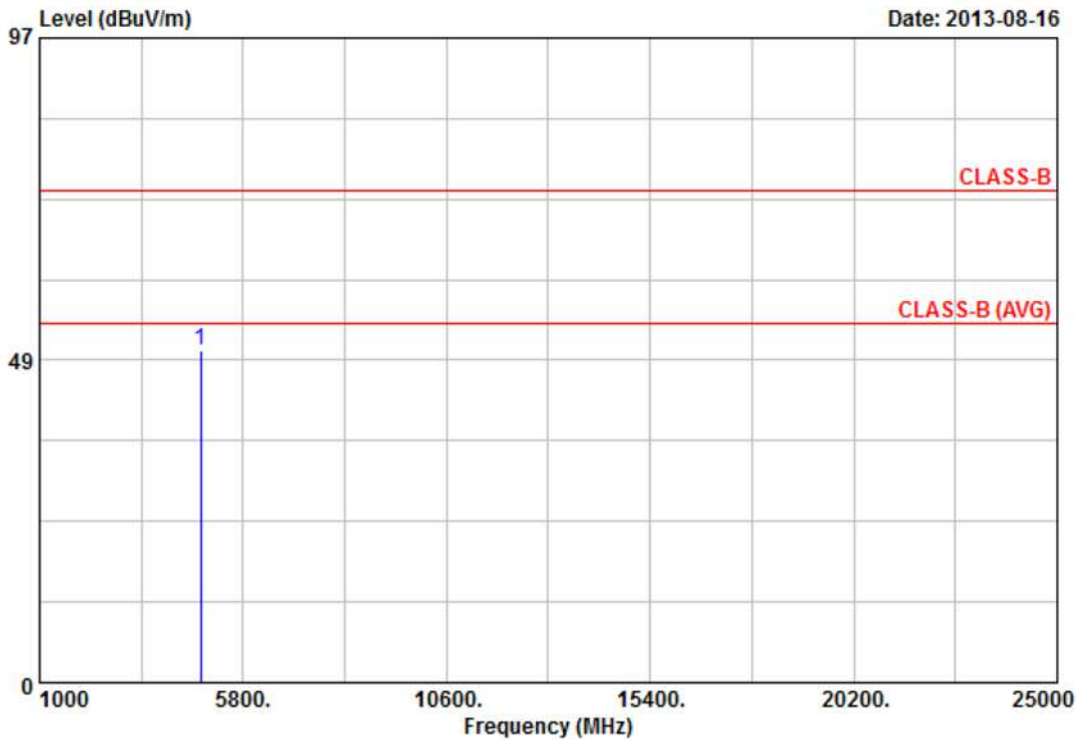

Item	Freq	Read Value	Factor	Result	Limit	Margin	Remark	Ant Pos	Tab Pos
	MHz	dBuV	dB/m	dBuV/m	dBuV/m	dB		cm	Deg
1	4804.00	44.66	5.27	49.93	74.00	-24.07	Peak	100	360

Notes:

1. Result = Read Value + Factor
2. Factor = Antenna Factor + Cable Loss - Amplifier
3. The resolution bandwidth of test receiver/spectrum analyzer is 120KHz and video bandwidth is 300kHz for Peak detection and Quasi-peak detection at frequency below 1GHz.
4. The resolution bandwidth of test receiver/spectrum analyzer is 1MHz and video bandwidth is 3MHz for Peak detection at frequency above 1GHz.
5. The resolution bandwidth of test receiver/spectrum analyzer is 1MHz and video bandwidth is 10Hz for Average detection at frequency above 1GHz.
6. The other emissions is too low to be measured.
7. The data is worse case.



Power	: DC 9V By Battery	Pol/Phase	: HORIZONTAL
Test Mode	: Transmit / Receive	Temperature	: 25 °C
Operation Channel	: 0	Humidity	: 46 %
Modulation Type	: 8DPSK (3 Mbps)	Atmospheric Pressure	: 1017 hPa

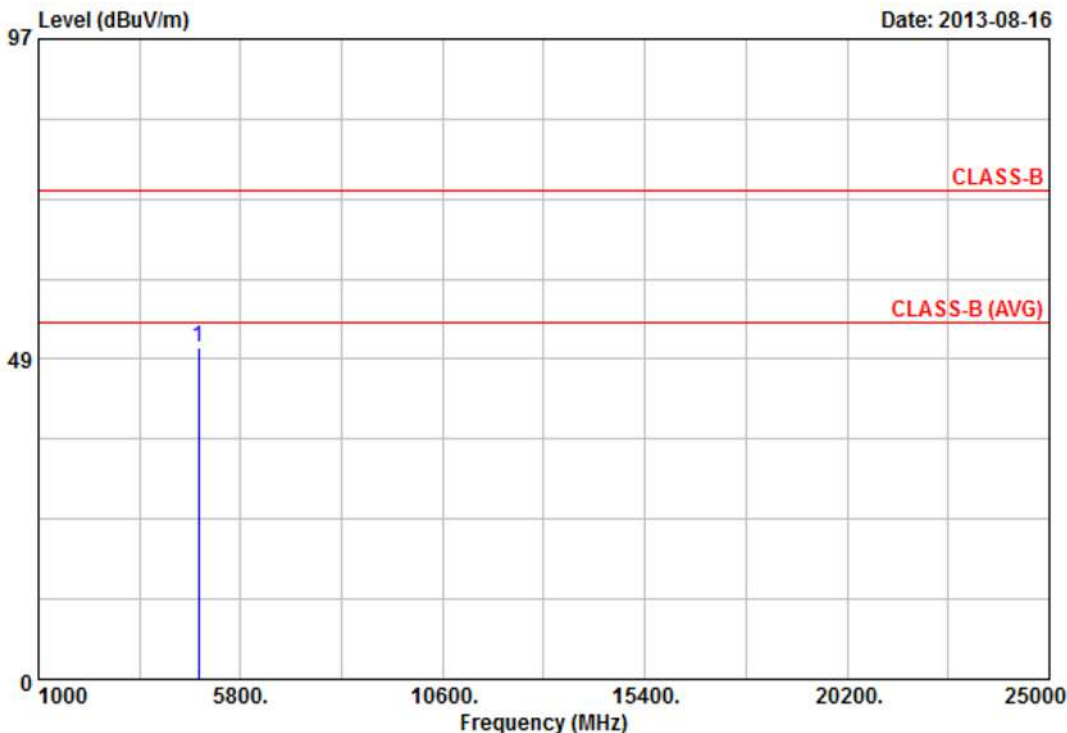

Item	Freq	Read Value	Factor	Result	Limit	Margin	Remark	Ant Pos	Tab Pos
	MHz	dBuV	dB/m	dBuV/m	dBuV/m	dB		cm	Deg
1	4804.00	46.66	3.69	50.35	74.00	-23.65	Peak	100	0

Notes:

1. Result = Read Value + Factor
2. Factor = Antenna Factor + Cable Loss - Amplifier
3. The resolution bandwidth of test receiver/spectrum analyzer is 120KHz and video bandwidth is 300kHz for Peak detection and Quasi-peak detection at frequency below 1GHz.
4. The resolution bandwidth of test receiver/spectrum analyzer is 1MHz and video bandwidth is 3MHz for Peak detection at frequency above 1GHz.
5. The resolution bandwidth of test receiver/spectrum analyzer is 1MHz and video bandwidth is 10Hz for Average detection at frequency above 1GHz.
6. The other emissions is too low to be measured.
7. The data is worse case.



Power	: DC 9V By Battery	Pol/Phase	: VERTICAL
Test Mode	: Transmit / Receive	Temperature	: 25 °C
Operation Channel	: 39	Humidity	: 46 %
Modulation Type	: 8DPSK (3 Mbps)	Atmospheric Pressure	: 1017 hPa

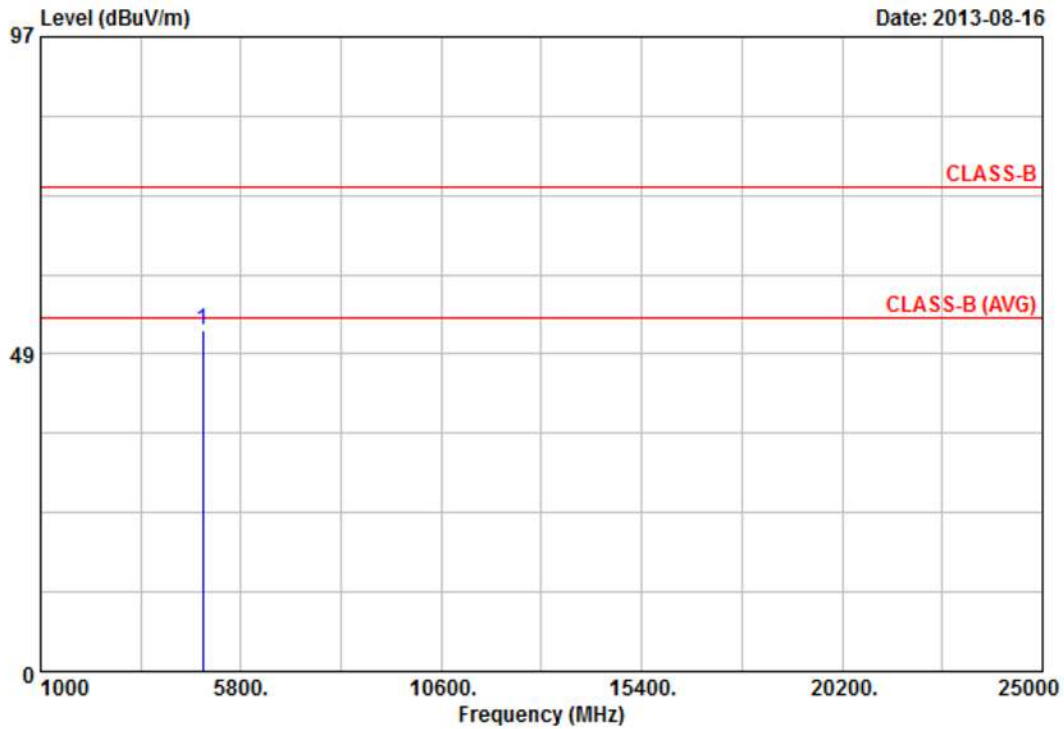

Item	Freq	Read Value	Factor	Result	Limit	Margin	Remark	Ant Pos	Tab Pos
	MHz	dBuV	dB/m	dBuV/m	dBuV/m	dB		cm	Deg
1	4882.00	45.45	6.81	52.26	74.00	-21.74	Peak	100	360

Notes:

1. Result = Read Value + Factor
2. Factor = Antenna Factor + Cable Loss - Amplifier
3. The resolution bandwidth of test receiver/spectrum analyzer is 120KHz and video bandwidth is 300kHz for Peak detection and Quasi-peak detection at frequency below 1GHz.
4. The resolution bandwidth of test receiver/spectrum analyzer is 1MHz and video bandwidth is 3MHz for Peak detection at frequency above 1GHz.
5. The resolution bandwidth of test receiver/spectrum analyzer is 1MHz and video bandwidth is 10Hz for Average detection at frequency above 1GHz.
6. The other emissions is too low to be measured.
7. The data is worse case.



Power	: DC 9V By Battery	Pol/Phase	: HORIZONTAL
Test Mode	: Transmit / Receive	Temperature	: 25 °C
Operation Channel	: 39	Humidity	: 46 %
Modulation Type	: 8DPSK (3 Mbps)	Atmospheric Pressure	: 1017 hPa

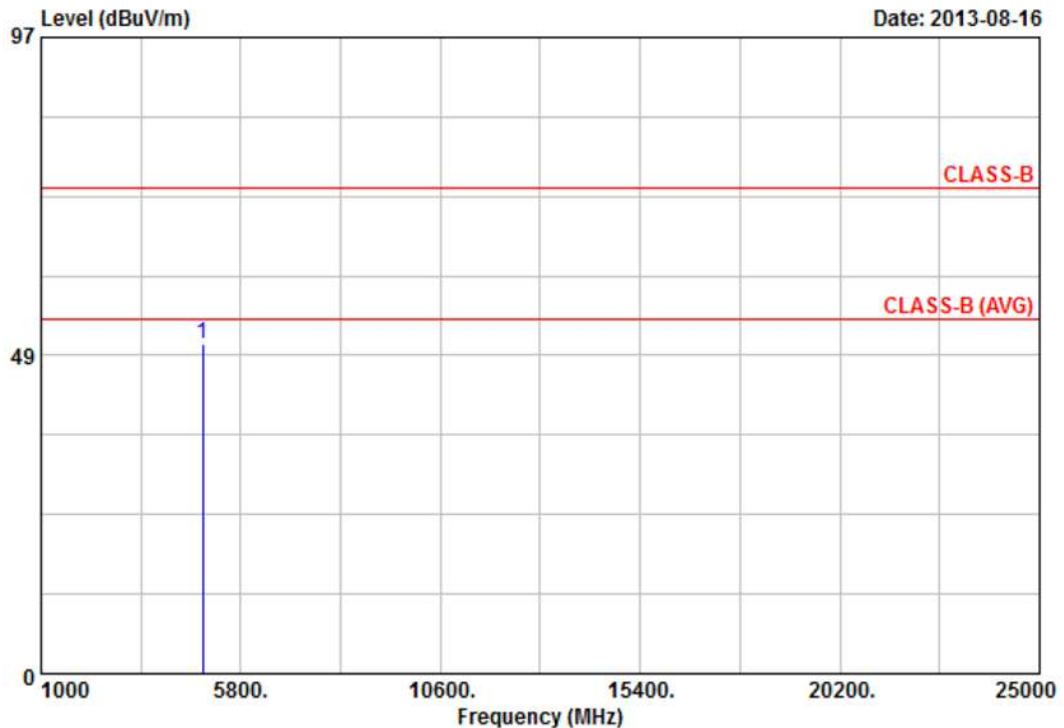

Item	Freq	Read Value	Factor	Result	Limit	Margin	Remark	Ant Pos	Tab Pos
	MHz	dBuV	dB/m	dBuV/m	dBuV/m	dB		cm	Deg
1	4882.00	45.36	4.92	50.28	74.00	-23.72	Peak	100	0

Notes:

1. Result = Read Value + Factor
2. Factor = Antenna Factor + Cable Loss - Amplifier
3. The resolution bandwidth of test receiver/spectrum analyzer is 120KHz and video bandwidth is 300kHz for Peak detection and Quasi-peak detection at frequency below 1GHz.
4. The resolution bandwidth of test receiver/spectrum analyzer is 1MHz and video bandwidth is 3MHz for Peak detection at frequency above 1GHz.
5. The resolution bandwidth of test receiver/spectrum analyzer is 1MHz and video bandwidth is 10Hz for Average detection at frequency above 1GHz.
6. The other emissions is too low to be measured.
7. The data is worse case.



Power	: DC 9V By Battery	Pol/Phase	: VERTICAL
Test Mode	: Transmit / Receive	Temperature	: 25 °C
Operation Channel	: 78	Humidity	: 46 %
Modulation Type	: 8DPSK (3 Mbps)	Atmospheric Pressure	: 1017 hPa

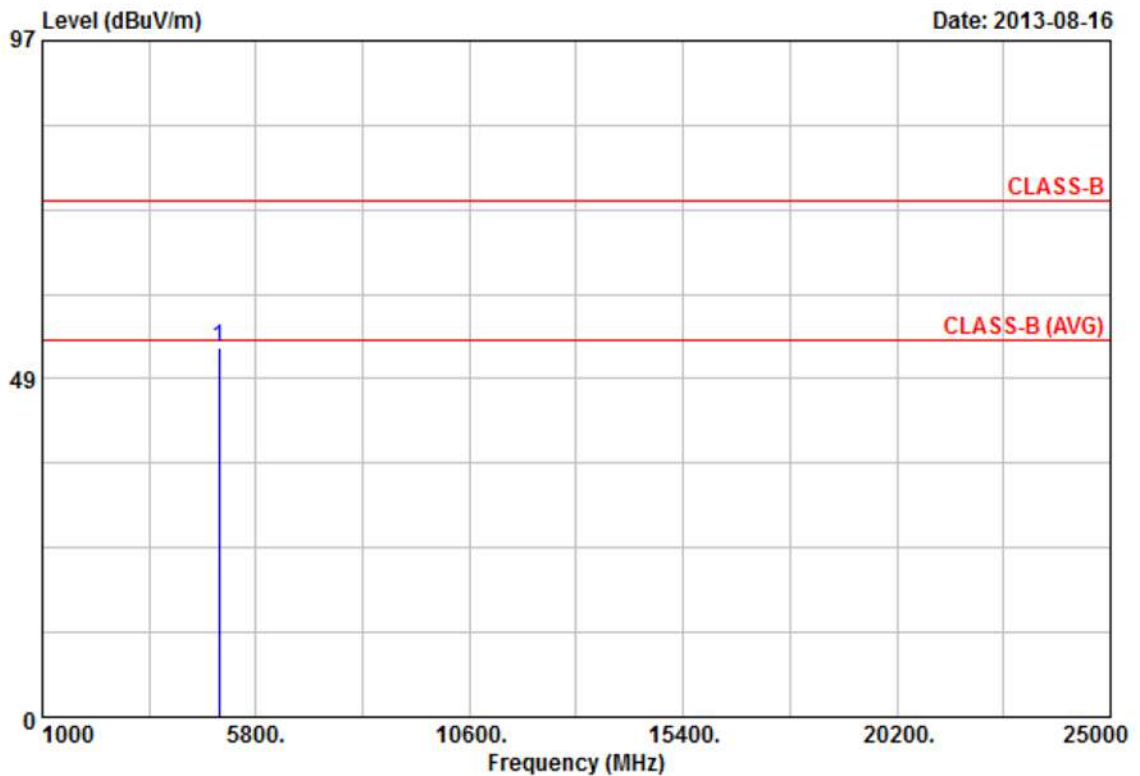

Item	Freq	Read Value	Factor	Result	Limit	Margin	Remark	Ant Pos	Tab Pos
	MHz	dBuV	dB/m	dBuV/m	dBuV/m	dB		cm	Deg
1	4960.00	45.66	7.32	52.98	74.00	-21.02	Peak	100	360

Notes:

1. Result = Read Value + Factor
2. Factor = Antenna Factor + Cable Loss - Amplifier
3. The resolution bandwidth of test receiver/spectrum analyzer is 120KHz and video bandwidth is 300kHz for Peak detection and Quasi-peak detection at frequency below 1GHz.
4. The resolution bandwidth of test receiver/spectrum analyzer is 1MHz and video bandwidth is 3MHz for Peak detection at frequency above 1GHz.
5. The resolution bandwidth of test receiver/spectrum analyzer is 1MHz and video bandwidth is 10Hz for Average detection at frequency above 1GHz.
6. The other emissions is too low to be measured.
7. The data is worse case.



Power	: DC 9V By Battery	Pol/Phase	: HORIZONTAL
Test Mode	: Transmit / Receive	Temperature	: 25 °C
Operation Channel	: 78	Humidity	: 46 %
Modulation Type	: 8DPSK (3 Mbps)	Atmospheric Pressure	: 1017 hPa

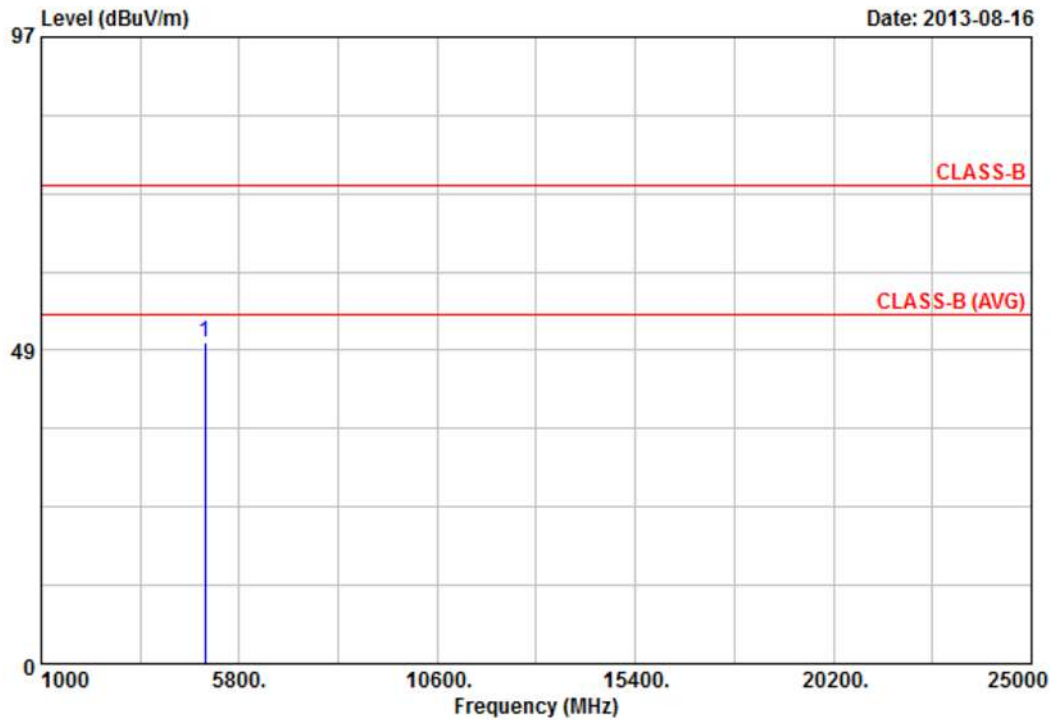

Item	Freq	Read Value	Factor	Result	Limit	Margin	Remark	Ant Pos	Tab Pos
	MHz	dBuV	dB/m	dBuV/m	dBuV/m	dB		cm	Deg
1	4960.00	44.54	5.22	49.76	74.00	-24.24	Peak	100	0

Notes:

1. Result = Read Value + Factor
2. Factor = Antenna Factor + Cable Loss - Amplifier
3. The resolution bandwidth of test receiver/spectrum analyzer is 120KHz and video bandwidth is 300kHz for Peak detection and Quasi-peak detection at frequency below 1GHz.
4. The resolution bandwidth of test receiver/spectrum analyzer is 1MHz and video bandwidth is 3MHz for Peak detection at frequency above 1GHz.
5. The resolution bandwidth of test receiver/spectrum analyzer is 1MHz and video bandwidth is 10Hz for Average detection at frequency above 1GHz.
6. The other emissions is too low to be measured.
7. The data is worse case.



6. 20dB Bandwidth Measurement Data

6.1 Test Limit

Frequency hopping systems shall have hopping channel carrier frequencies separated by a minimum of 25 kHz or the 20 dB bandwidth of the hopping channel, whichever is greater. Alternatively, frequency hopping systems operating in the 2400–2483.5 MHz band may have hopping channel carrier frequencies that are separated by 25 kHz or two-thirds of the 20 dB bandwidth of the hopping channel, whichever is greater, provided the systems operate with an output power no greater than 125 mW.

6.2 Test Procedures

- a. The transmitter output was connected to the spectrum analyzer.
- b. Set RBW of spectrum analyzer to 30 KHz and VBW to 100 KHz.
- c. The 20 dB bandwidth is defined as the total spectrum the power of which is higher than peak power minus 20 dB.

6.3 Test Setup Layout

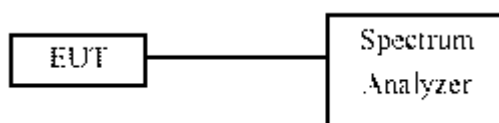

6.4 Measurement equipment

Instrument/Ancillary	Model No.	Manufacturer	Serial No.	Calibration Date	Valid Date
Spectrum Analyzer	R&S	FSP40	100047	2013/03/15	2014/03/14



6.5 Test Result and Data

Test Date: Aug. 09, 2013

Temperature: 25 °C

Atmospheric pressure: 1015 hPa

Humidity: 43 %

Modulation Type	Channel	Frequency (MHz)	20dB Bandwidth (KHz)	2/3 20dB Bandwidth (KHz)
GFSK (1Mbps)	00	2402	1044.00	696.00
	39	2441	1048.00	698.67
	78	2480	1044.00	696.00
$\pi/4$ -DQPSK (2 Mbps)	00	2402	1232.00	821.33
	39	2441	1236.00	824.00
	78	2480	1240.00	826.67
8DPSK (3Mbps)	00	2402	1180.00	786.67
	39	2441	1184.00	789.33
	78	2480	1180.00	786.67



Modulation Standard: GFSK (1Mbps)
Channel: 00



*RBW 30 kHz Delta 2 [T1]
*VBW 100 kHz 0.42 dB
*SWT 50 ms 1.044300000 MHz

Ref 20 dBm *Att 30 dB

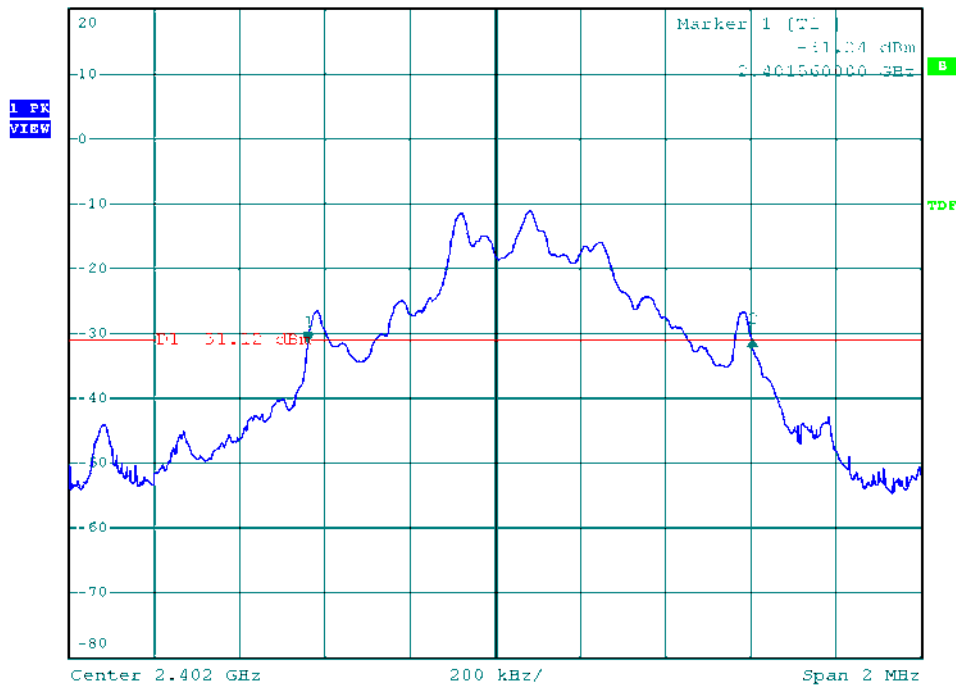

Modulation Standard: GFSK (1Mbps)
Channel: 39



*RBW 30 kHz Delta 2 [T1]
*VBW 100 kHz -0.40 dB
*SWT 50 ms 1.048000000 MHz

Ref 20 dBm *Att 30 dB

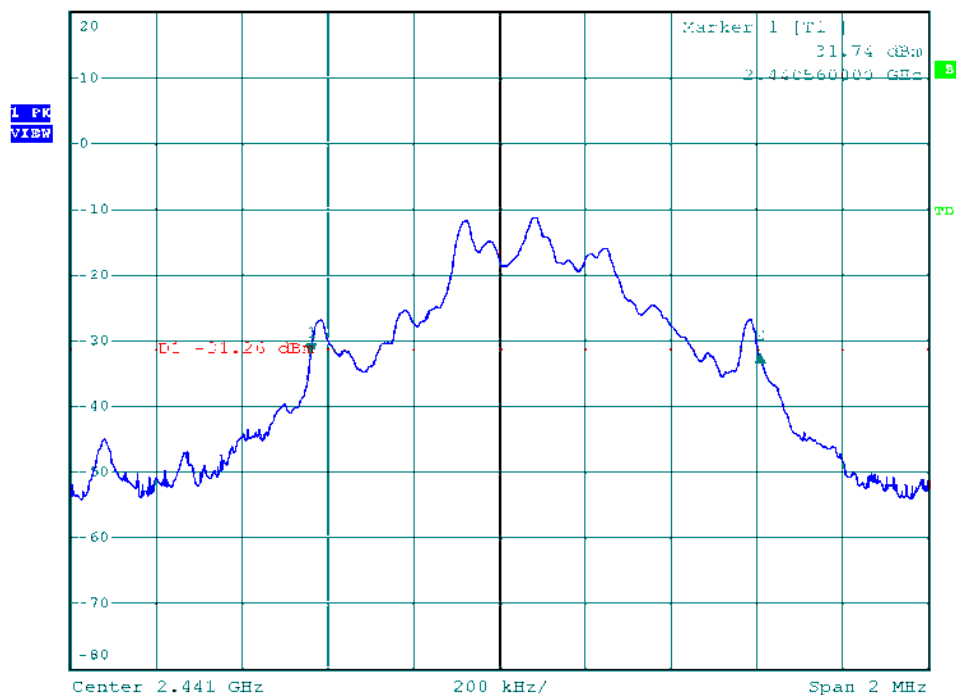



Modulation Standard: GFSK (1Mbps)
Channel: 78

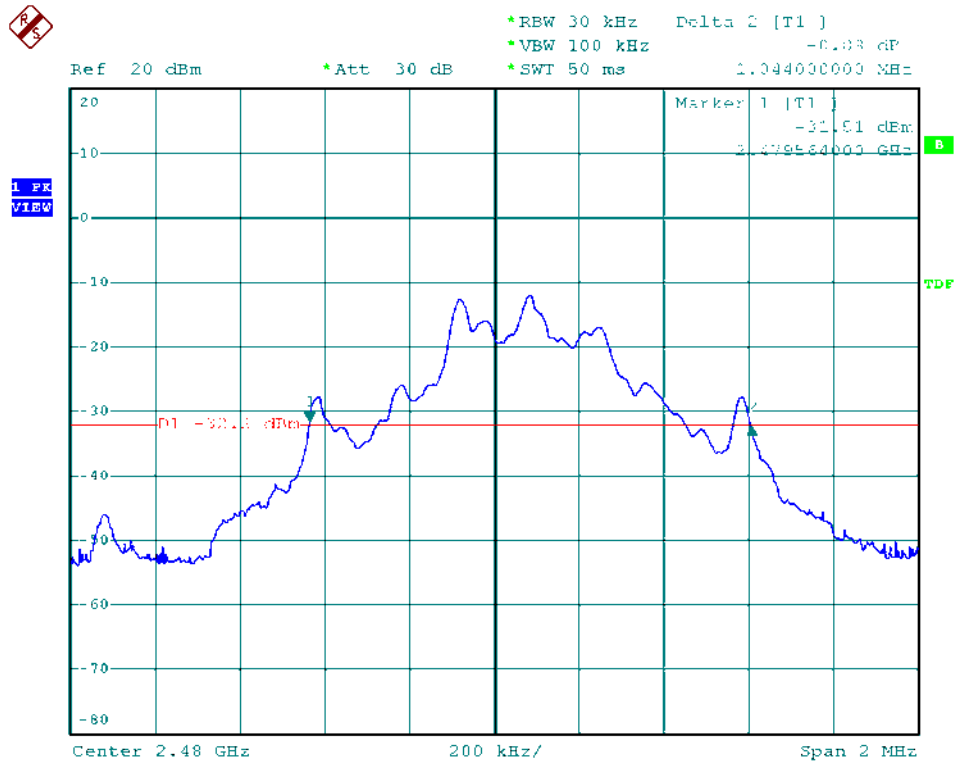

Modulation Standard: $\pi/4$ -DQPSK (2Mbps)
Channel: 00

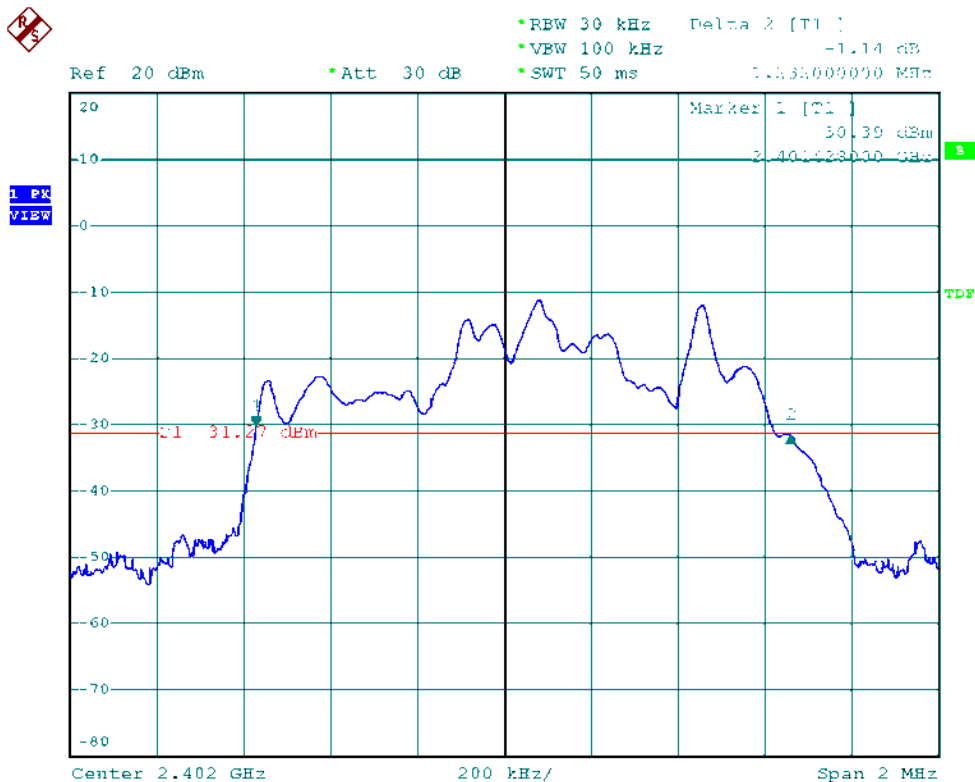



Modulation Standard: $\pi/4$ -DQPSK (2Mbps)
Channel: 39

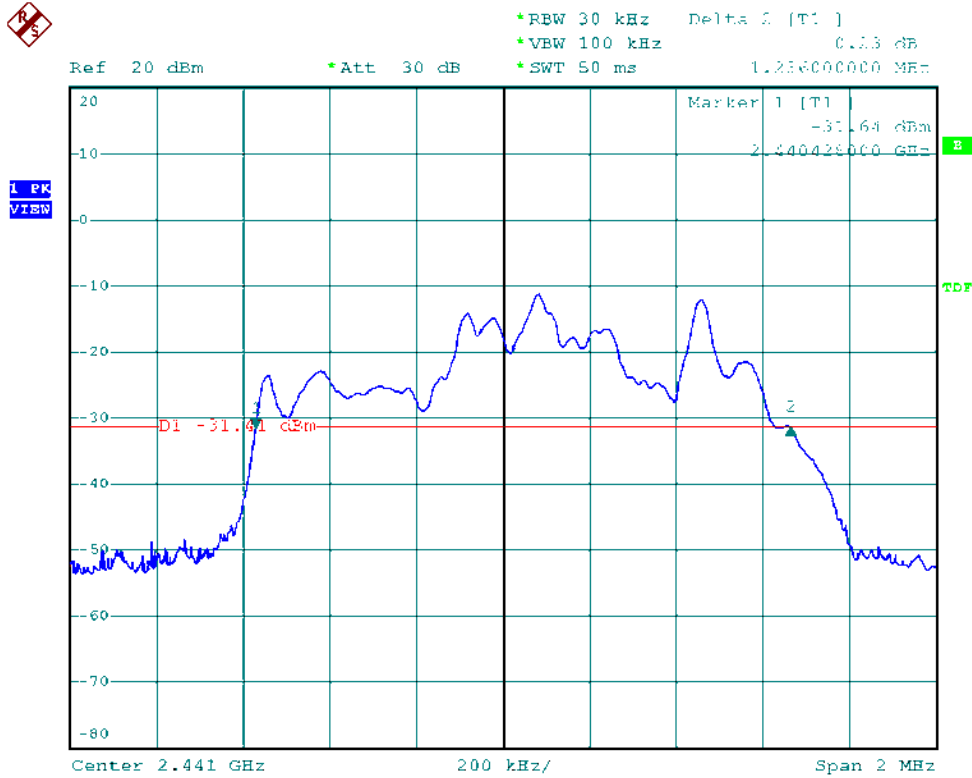

Modulation Standard: $\pi/4$ -DQPSK (2Mbps)
Channel: 78

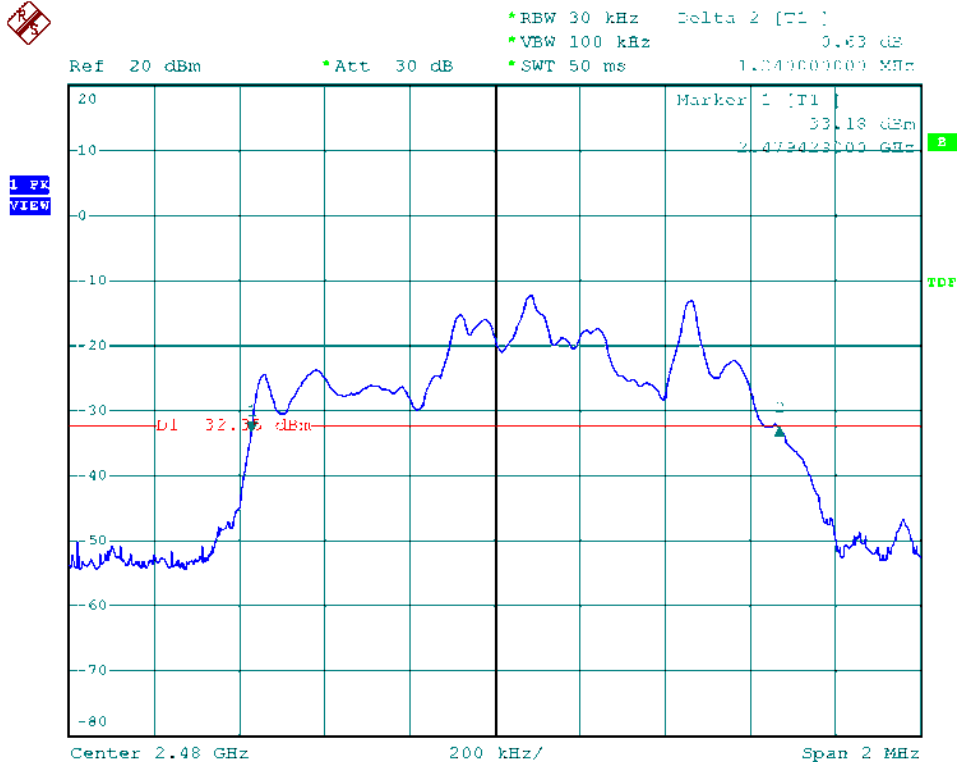



Modulation Standard: 8DPSK (3Mbps)
Channel: 00

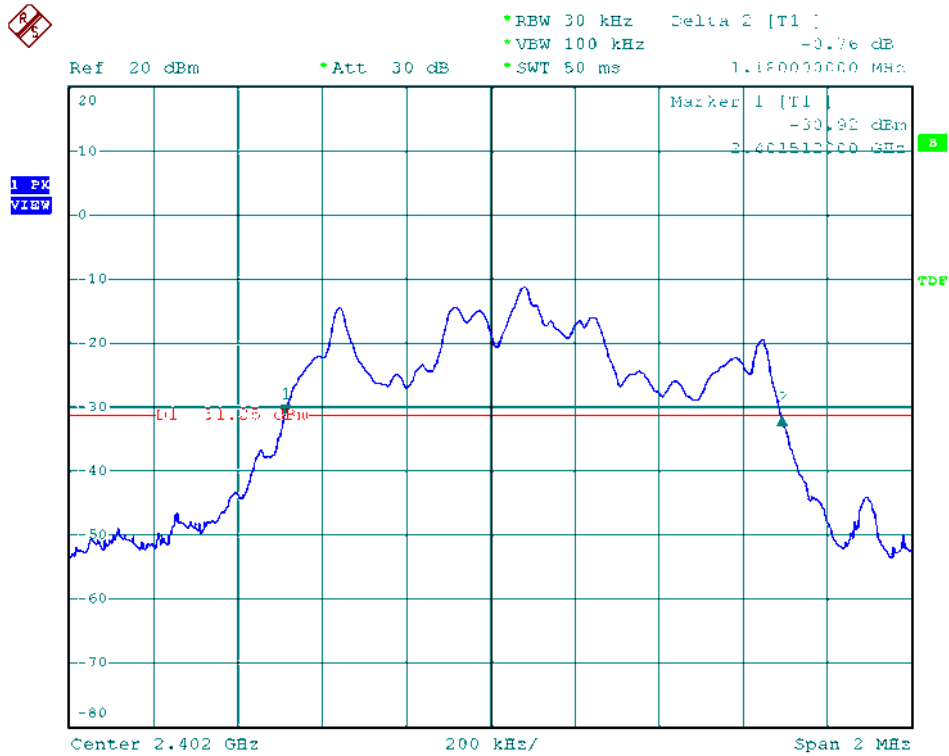

Modulation Standard: 8DPSK (3Mbps)
Channel: 39

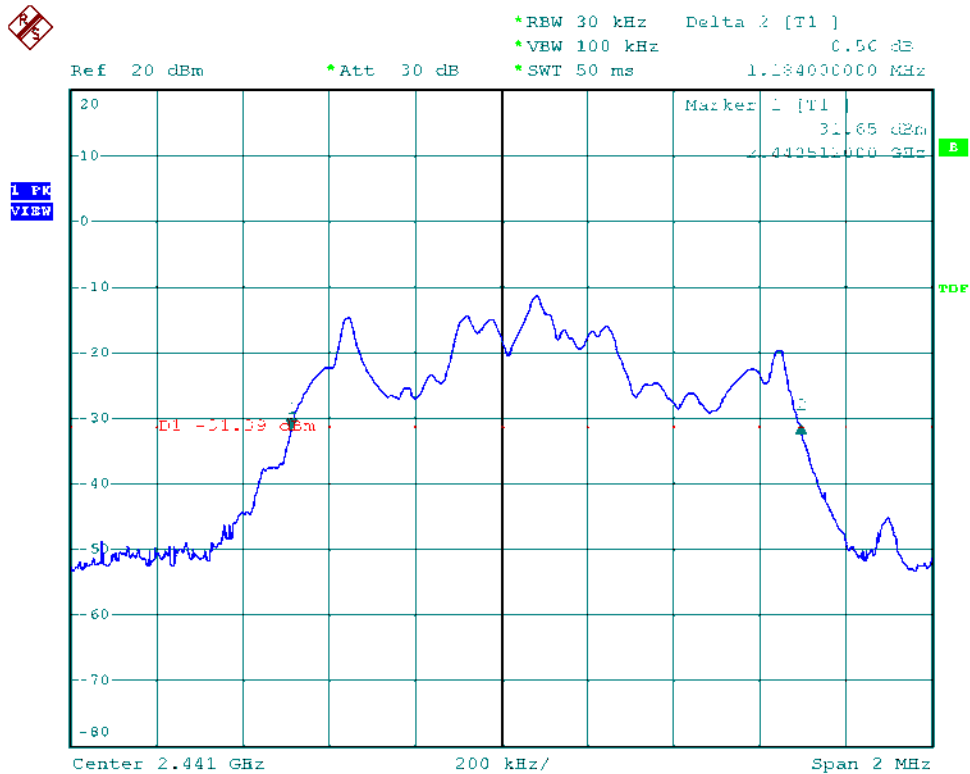



Modulation Standard: 8DPSK (3Mbps)
Channel: 78

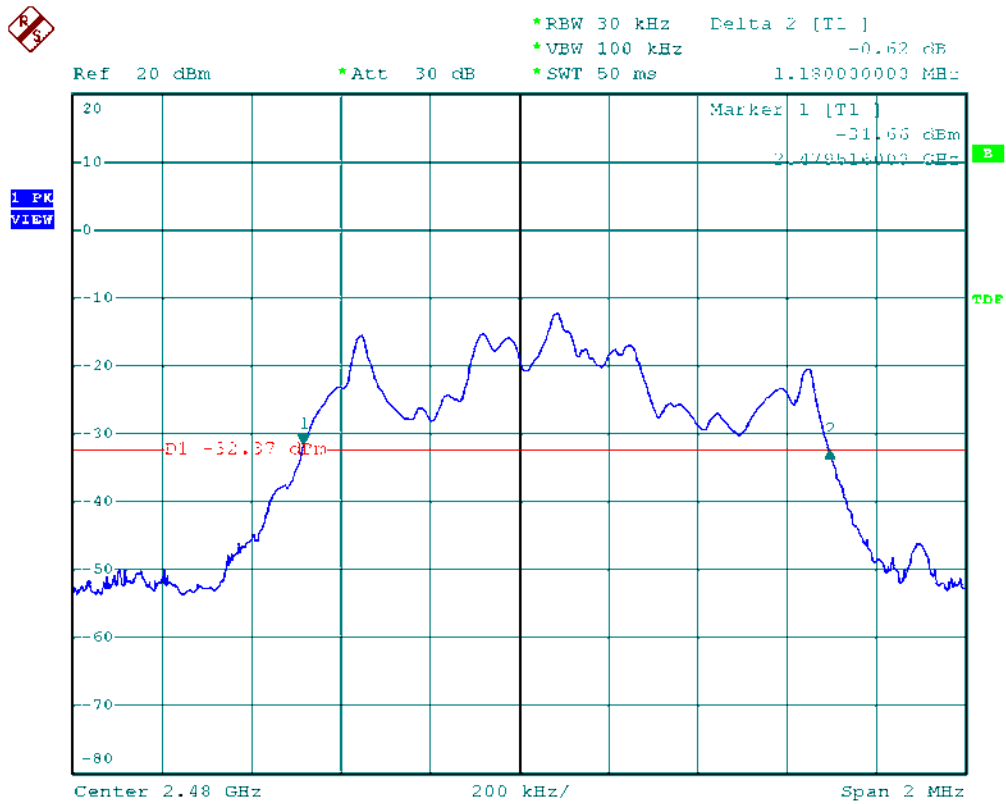



7. Frequencies Separation

7.1 Test Limit

Frequency hopping systems shall have hopping channel carrier frequencies separated by a minimum of 25 kHz or the 20 dB bandwidth of the hopping channel, whichever is greater.

7.2 Test Procedures

- The transmitter output was connected to the spectrum analyzer.
- Set RBW of spectrum analyzer to 100 KHz and VBW to 100 KHz.
- By using the MaxHold function record the separation of two adjacent channels.
- Measure the frequency difference of these two adjacent channels.

7.3 Test Setup Layout

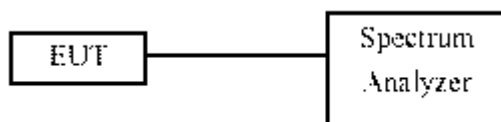

7.4 Measurement equipment

Instrument/Ancillary	Model No.	Manufacturer	Serial No.	Calibration Date	Valid Date
Spectrum Analyzer	R&S	FSP40	100047	2013/03/15	2014/03/14



7.5 Test Result and Data

Test Date: Aug. 09, 2013

Temperature: 25 °C

Atmospheric pressure: 1015 hPa

Humidity: 43 %

Modulation Type	Channel	Frequency (MHz)	Frequency Separation (MHz)
GFSK (1Mbps)	00	2402	1.000
	39	2441	1.000
	78	2480	1.004
$\pi/4$ -DQPSK (2 Mbps)	00	2402	1.004
	39	2441	1.000
	78	2480	1.000
8DPSK (3Mbps)	00	2402	1.004
	39	2441	1.000
	78	2480	1.004



Modulation Standard: GFSK (1Mbps)
Channel: 00

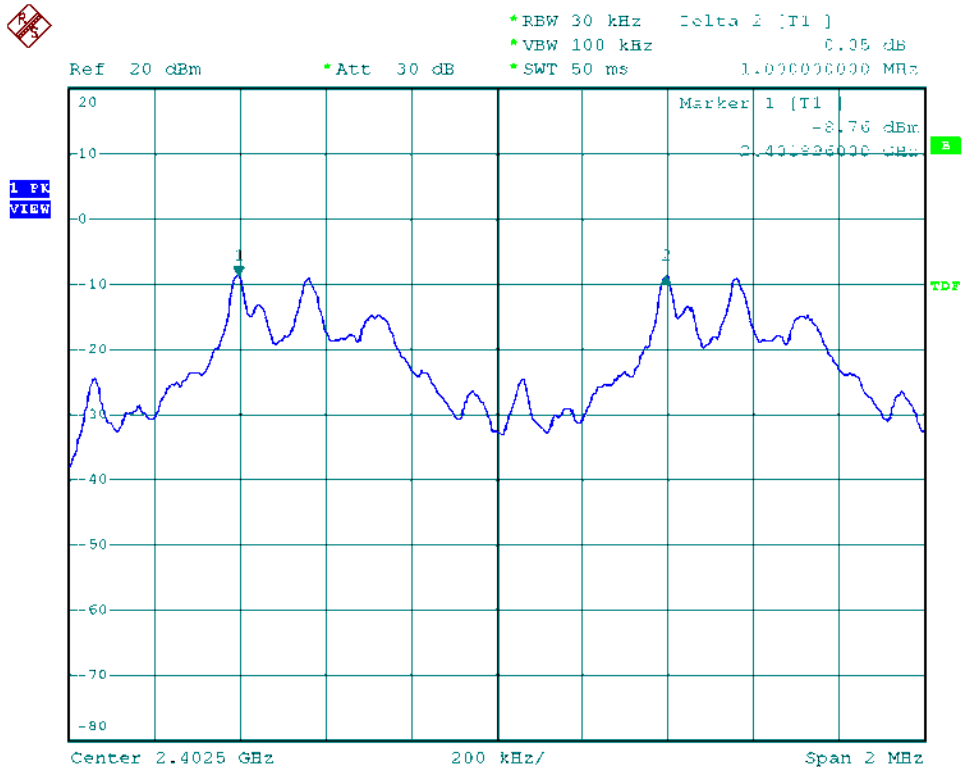

Modulation Standard: GFSK (1Mbps)
Channel: 39

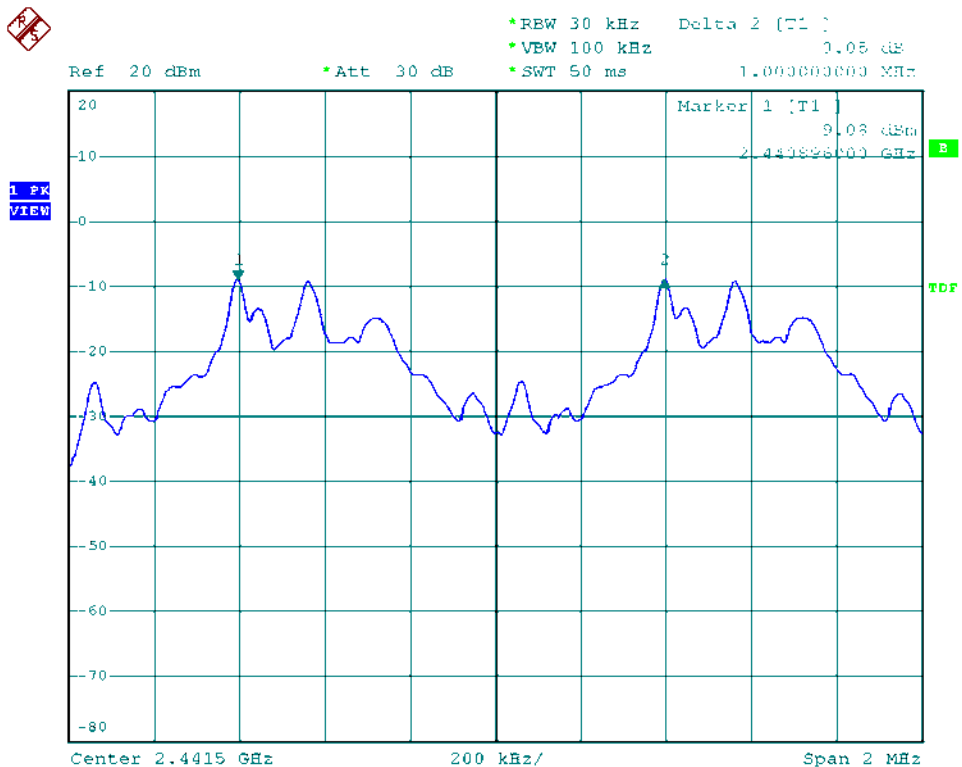



Modulation Standard: GFSK (1Mbps)
Channel: 78

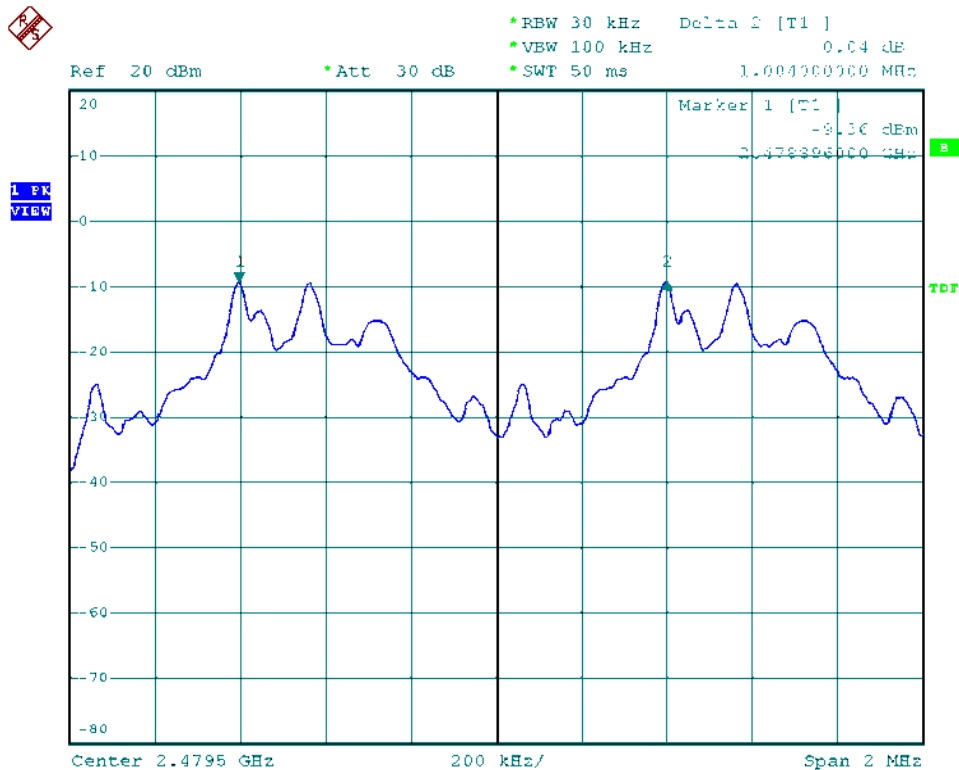

Modulation Standard: $\pi/4$ -DQPSK (2Mbps)
Channel: 00

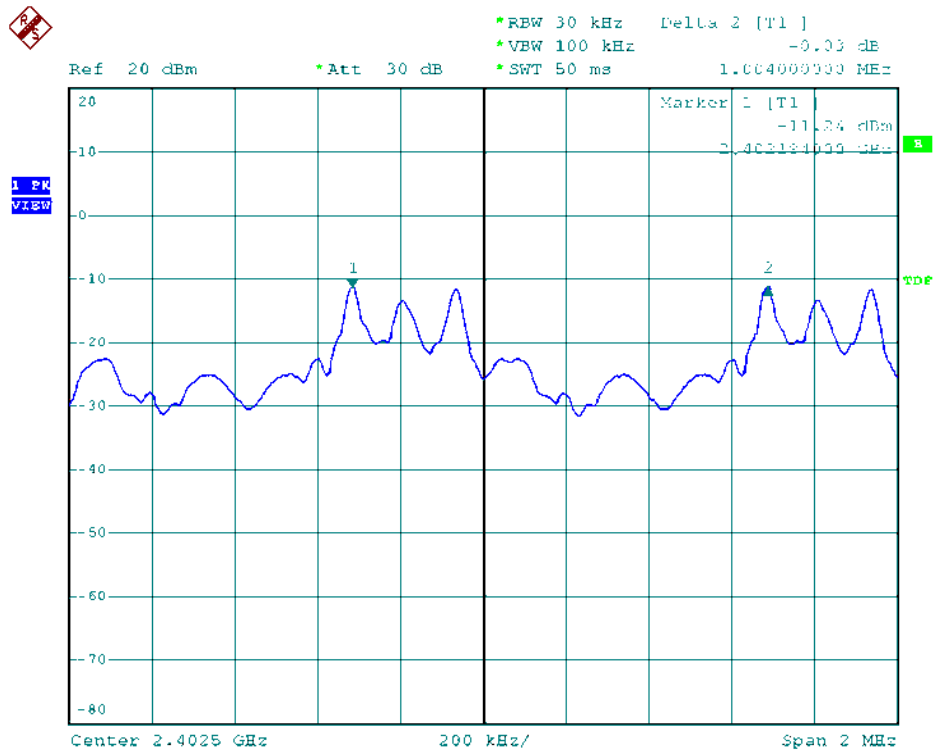



Modulation Standard: $\pi/4$ -DQPSK (2Mbps)
Channel: 39

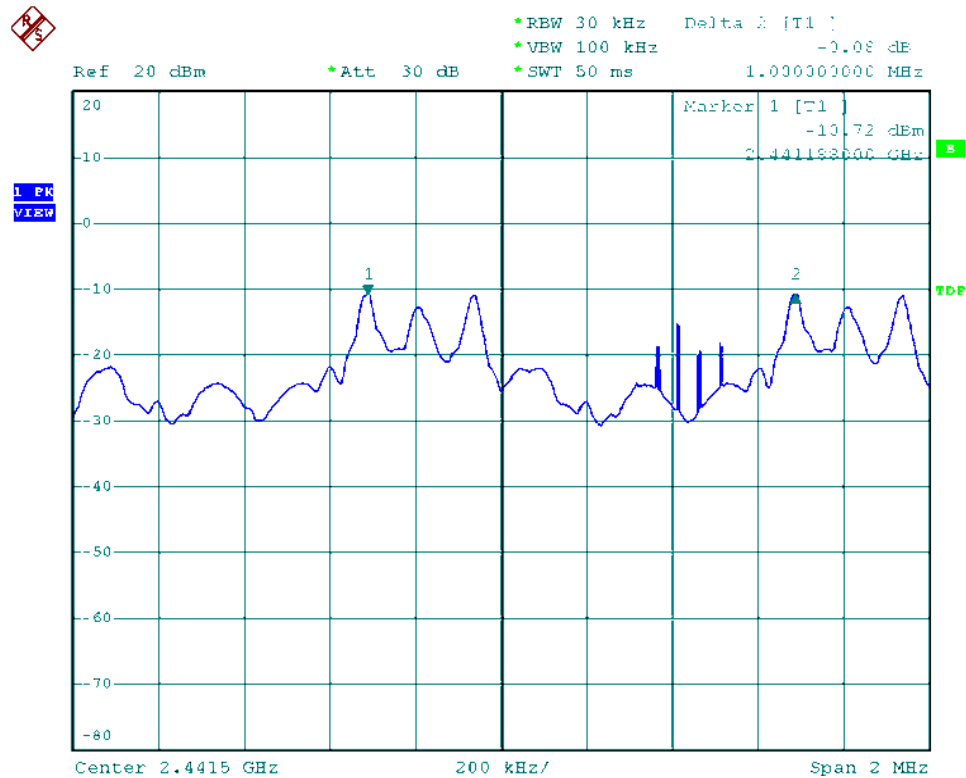

Modulation Standard: $\pi/4$ -DQPSK (2Mbps)
Channel: 78

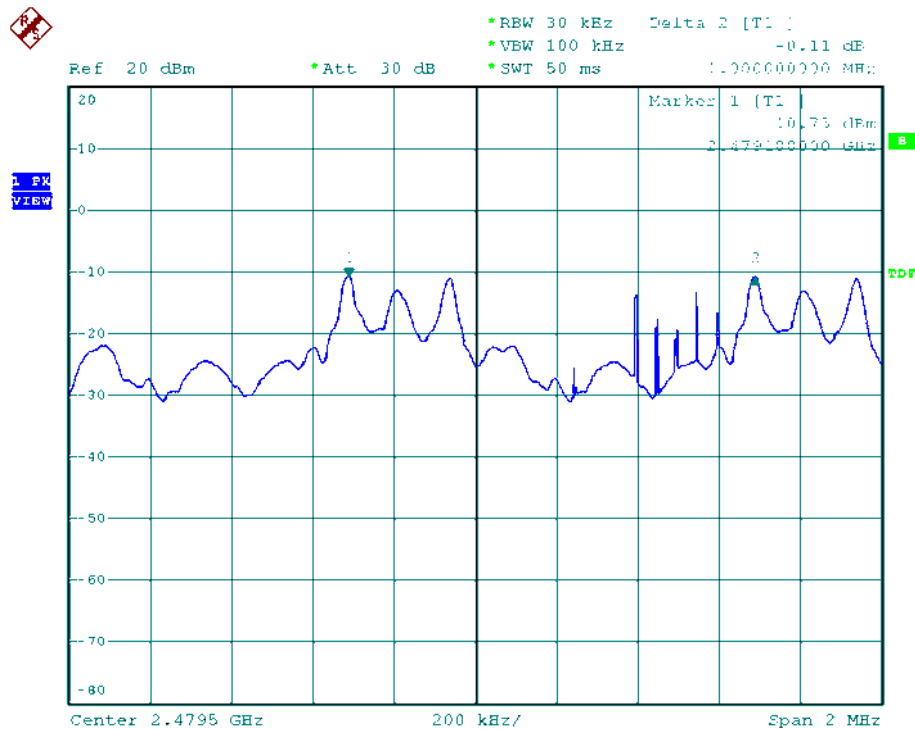



Modulation Standard: 8DPSK (3Mbps)
Channel: 00

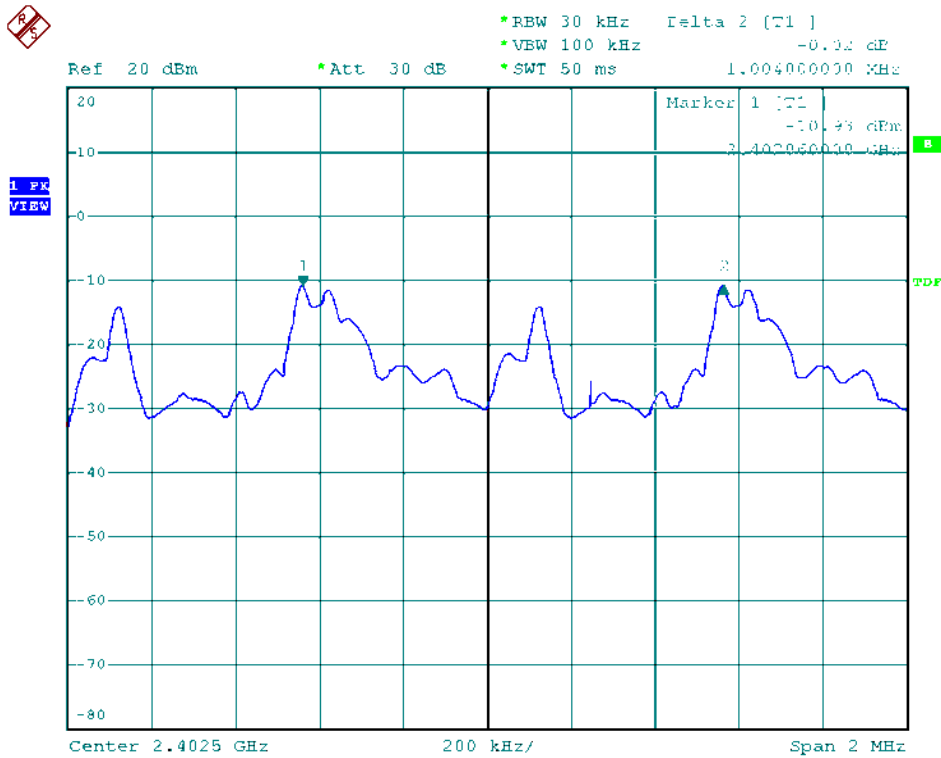

Modulation Standard: 8DPSK (3Mbps)
Channel: 39

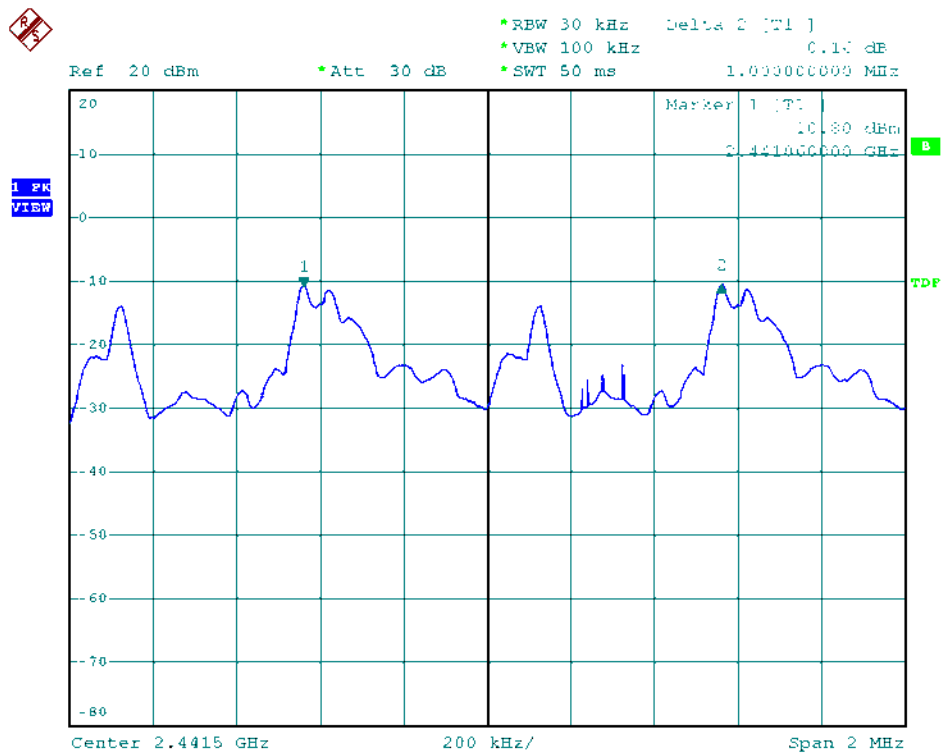



Modulation Standard: 8DPSK (3Mbps)
Channel: 78

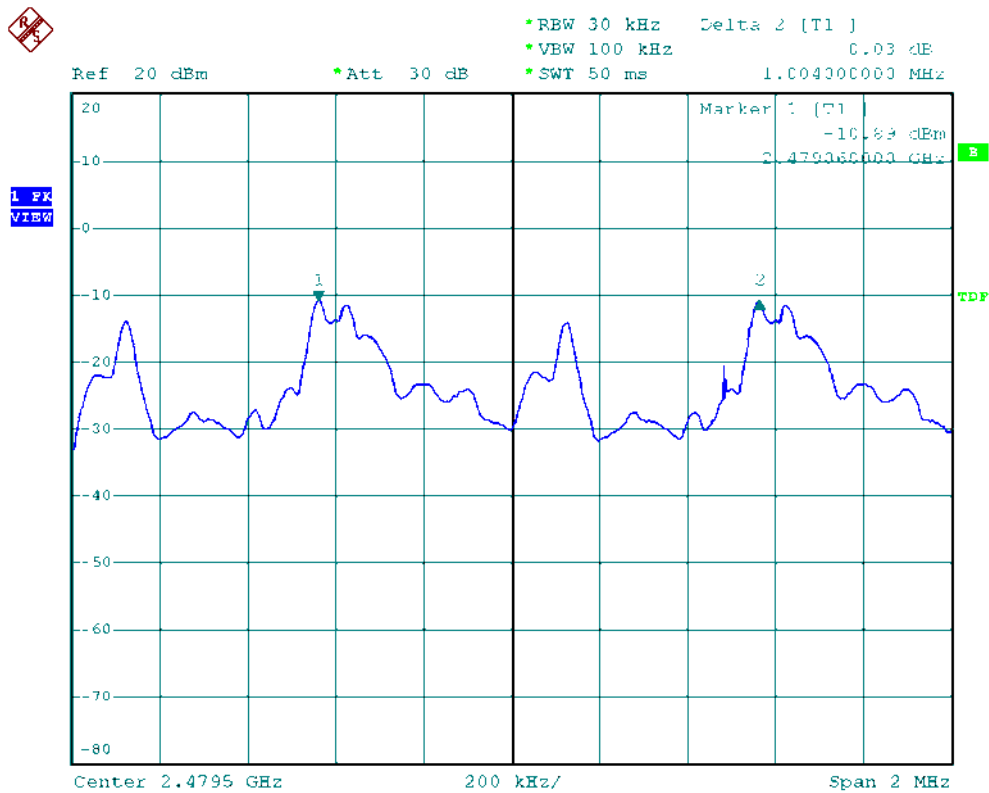



8. Dwell Time on each channel

8.1 Test Limit

The average time of occupancy on any channel shall not be greater than 0.4 seconds within a period of 0.4 seconds multiplied by the number of hopping channels employed.

8.2 Test Procedures

1. The transmitter output was connected to the spectrum analyzer.
2. Adjust the center frequency to measure frequency, then set zero span mode.
2. Set RBW of spectrum analyzer to 1 MHz and VBW to 1 MHz.
4. Measure the time duration of one transmission on the measured frequency.

8.3 Test Setup Layout

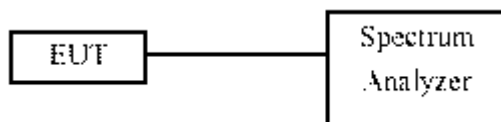

8.4 Measurement equipment

Instrument/Ancillary	Model No.	Manufacturer	Serial No.	Calibration Date	Valid Date
Spectrum Analyzer	R&S	FSP40	100047	2013/03/15	2014/03/14



8.5 Test Result and Data

Test Date: Aug. 09, 2013

Temperature: 25 °C

Atmospheric pressure: 1015 hPa

Humidity: 43 %

Modulation Type	Channel	Frequency (MHz)	Dwell Time (ms)
GFSK DH1	00	2402	146.61
	39	2441	146.61
	78	2480	146.61
GFSK DH3	00	2402	275.67
	39	2441	275.67
	78	2480	275.67
GFSK DH5	00	2402	317.87
	39	2441	317.87
	78	2480	317.87
$\pi/4$ -DQPSK 2DH5	00	2402	317.01
	39	2441	317.01
	78	2480	317.01
8DPSK 3DH5	00	2402	317.01
	39	2441	317.01
	78	2480	317.01

Test period: 0.4(second/ channel) x 79 channel=31.6 second

Example:

CH0, DH1 mode = $0.458 \text{ (ms)} * (1600/2)/79 * 31.6 = 146.61 \text{ (ms)}$ CH0, DH3 mode = $1.724 \text{ (ms)} * (1600/4)/79 * 31.6 = 275.67 \text{ (ms)}$ CH0, DH5 mode = $2.976 \text{ (ms)} * (1600/6)/79 * 31.6 = 317.87 \text{ (ms)}$



Modulation Standard: GFSK (1Mbps)
Channel: 00, Rate: DH1

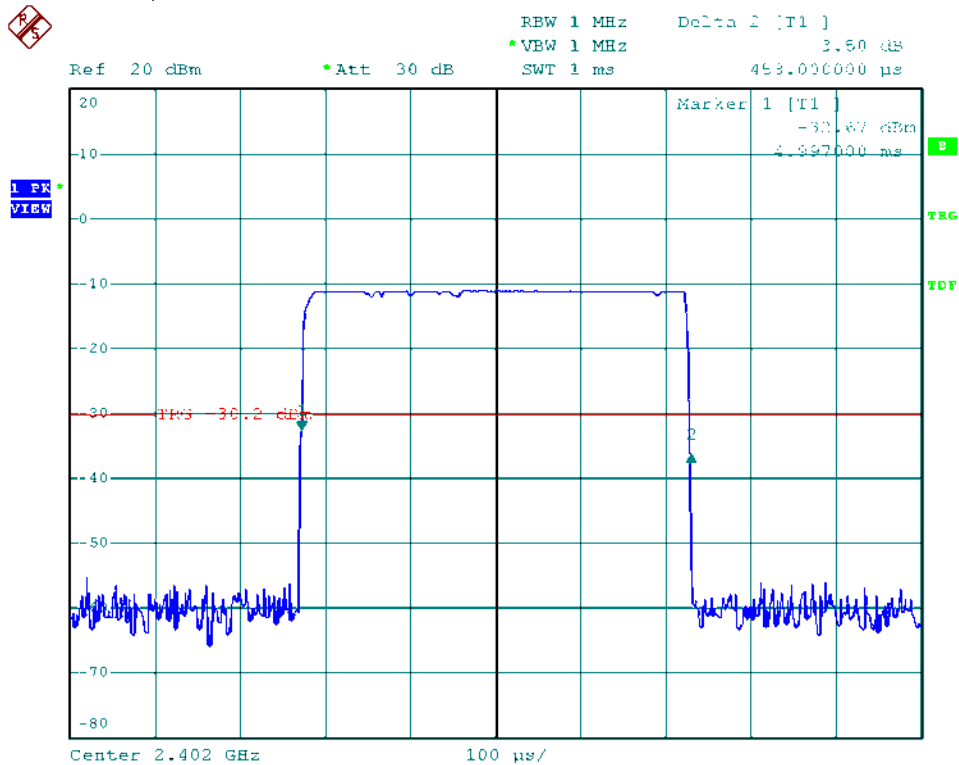

Modulation Standard: GFSK (1Mbps)
Channel: 00, Rate: DH3

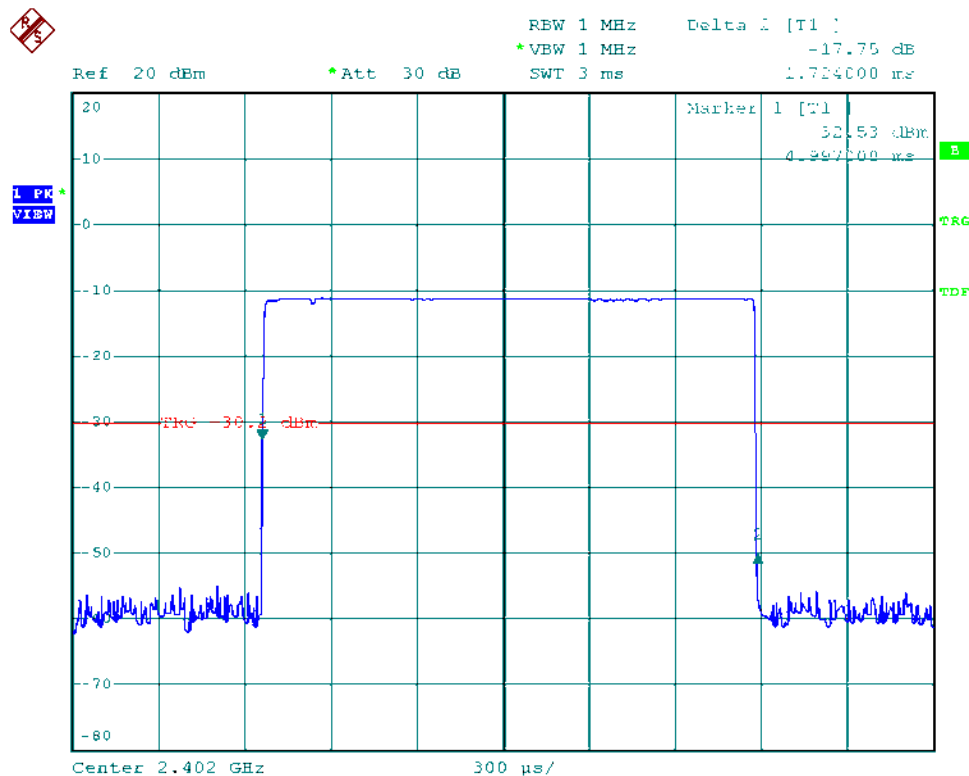



Modulation Standard: GFSK (1Mbps)
Channel: 00, Rate: DH5

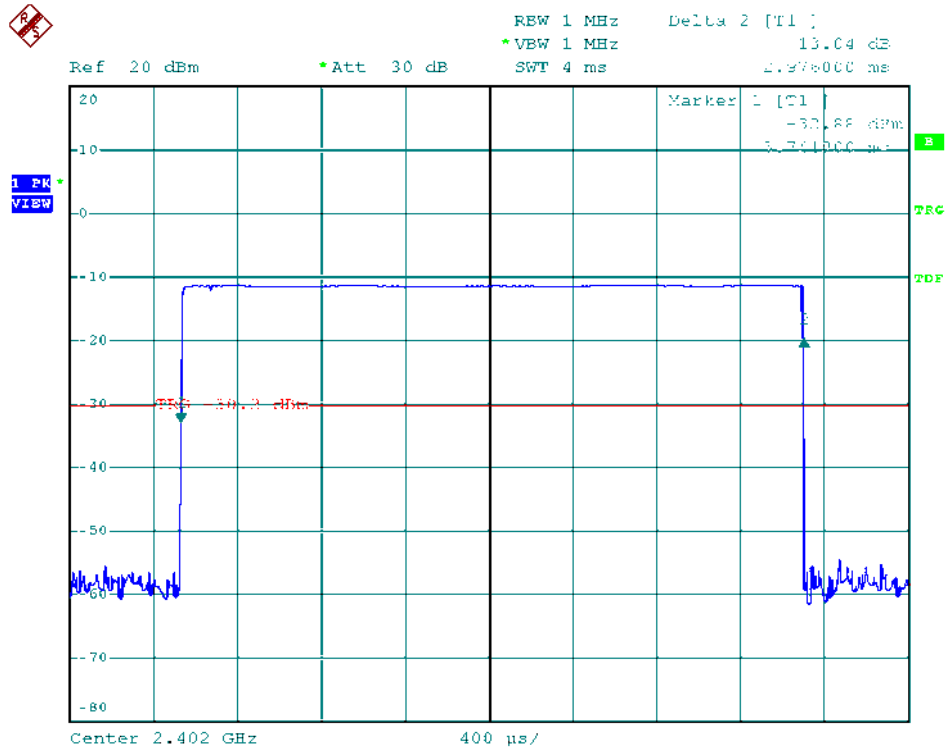

Modulation Standard: GFSK (1Mbps)
Channel: 39, Rate: DH1

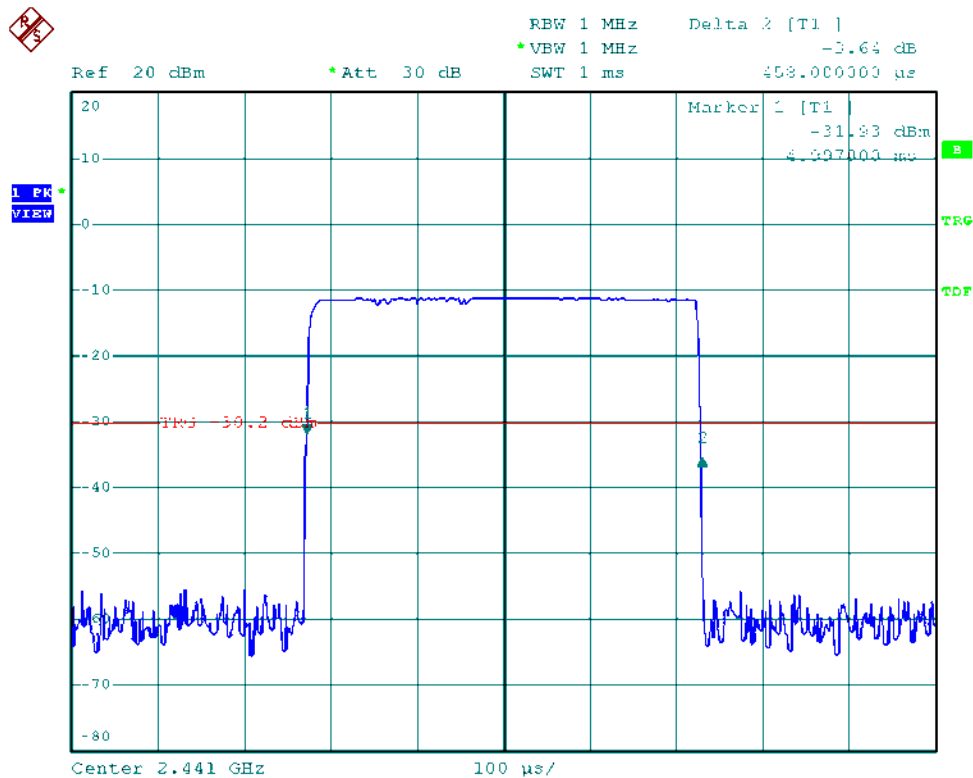



Modulation Standard: GFSK (1Mbps)
Channel: 39, Rate: DH3

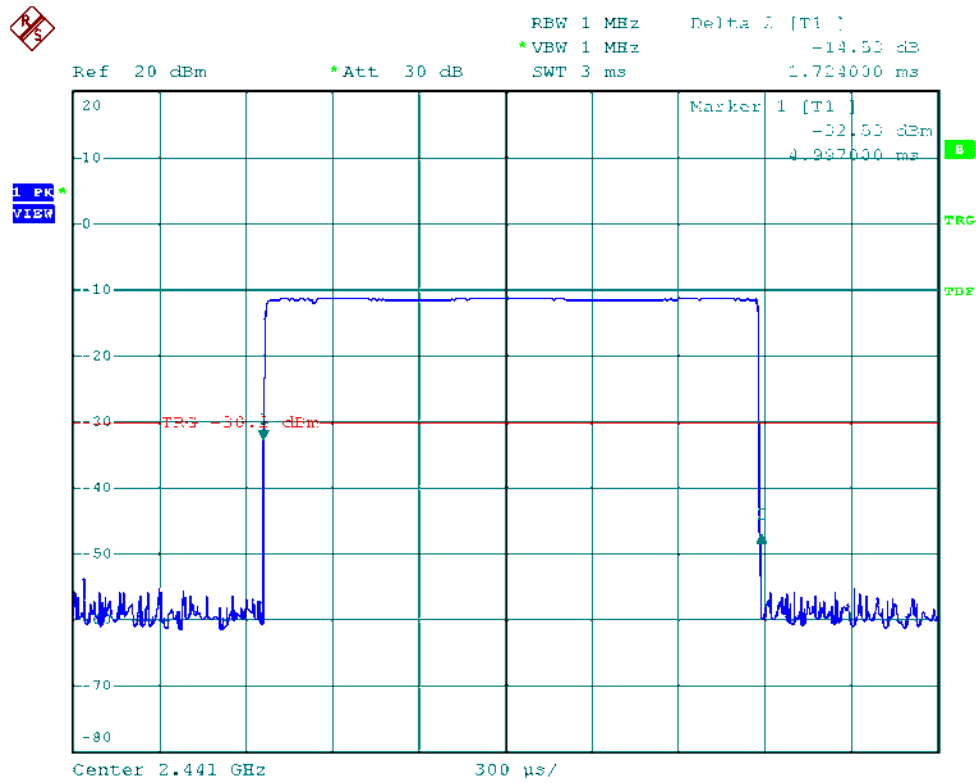

Modulation Standard: GFSK (1Mbps)
Channel: 39, Rate: DH5

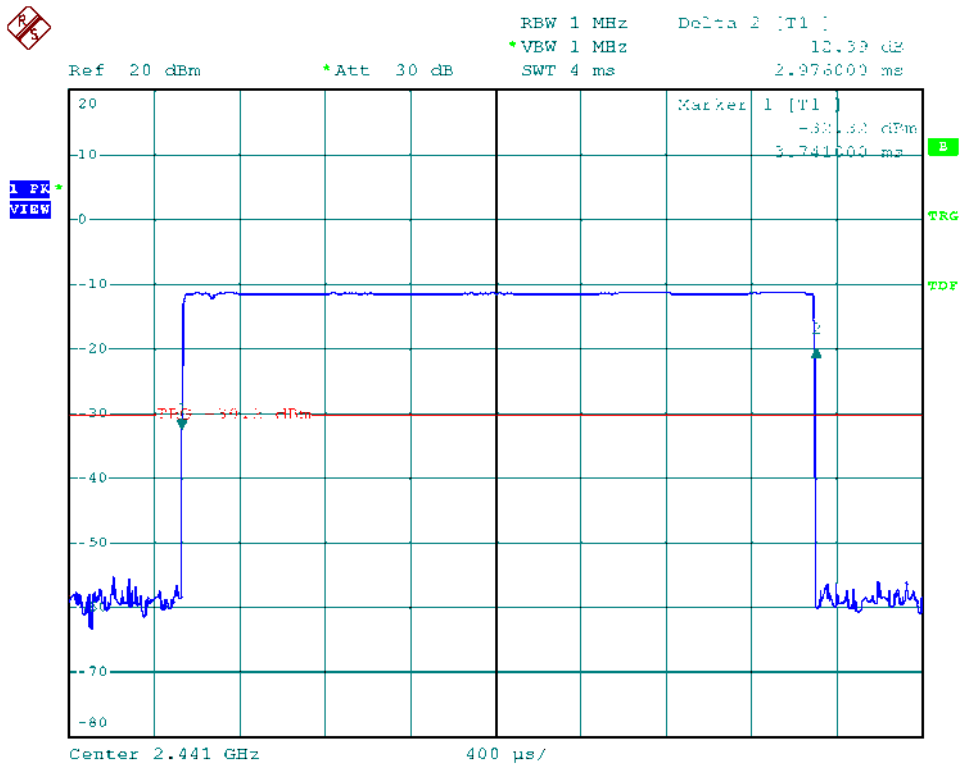



Modulation Standard: GFSK (1Mbps)
Channel: 78, Rate: DH1

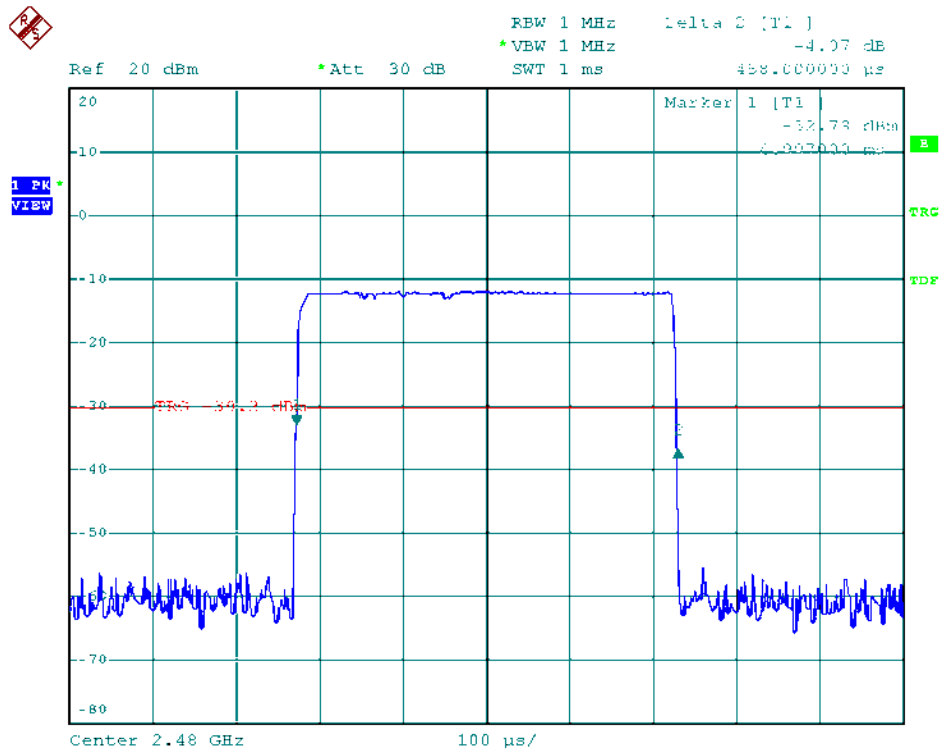

Modulation Standard: GFSK (1Mbps)
Channel: 78, Rate: DH3

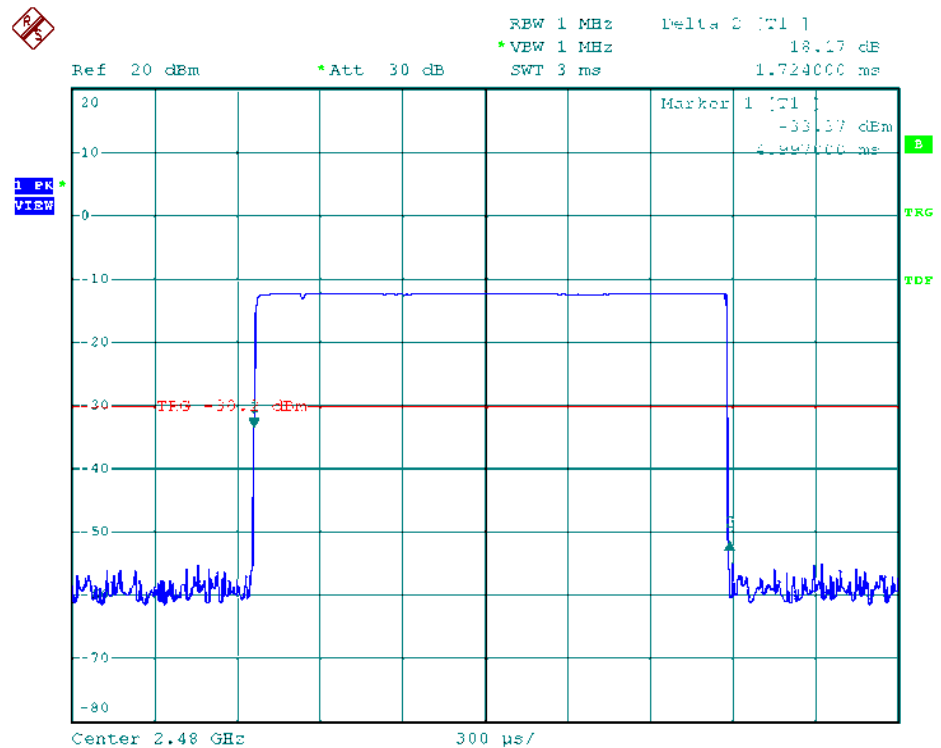



Modulation Standard: GFSK (1Mbps)
Channel: 78, Rate: DH5

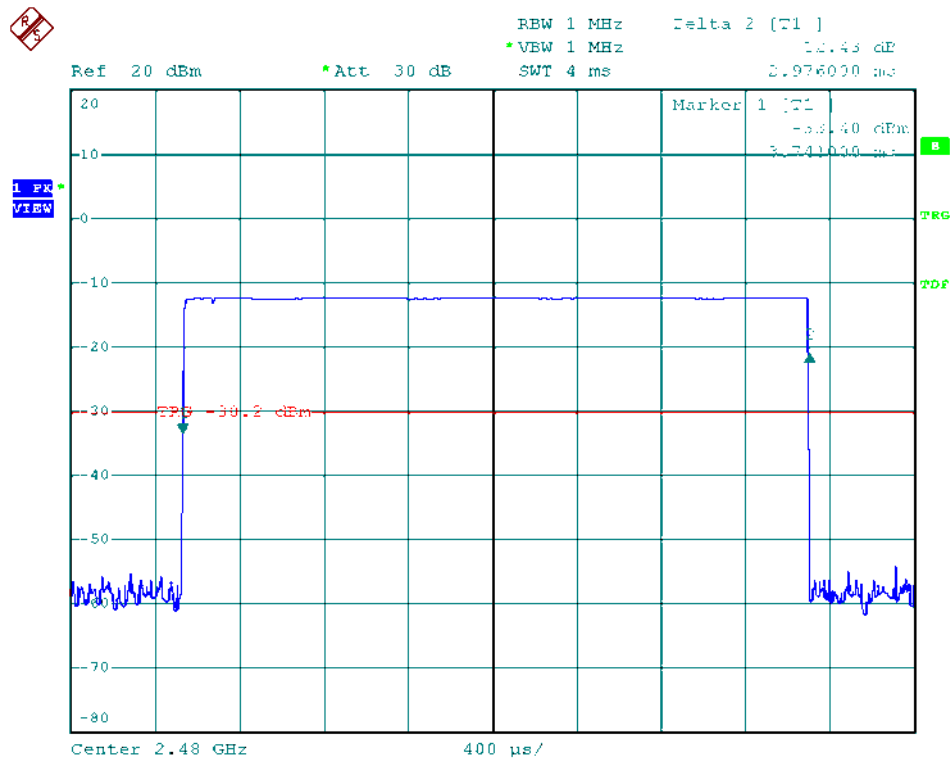

Modulation Standard: $\pi/4$ -DQPSK (2Mbps)
Channel: 00, Rate: 2DH5

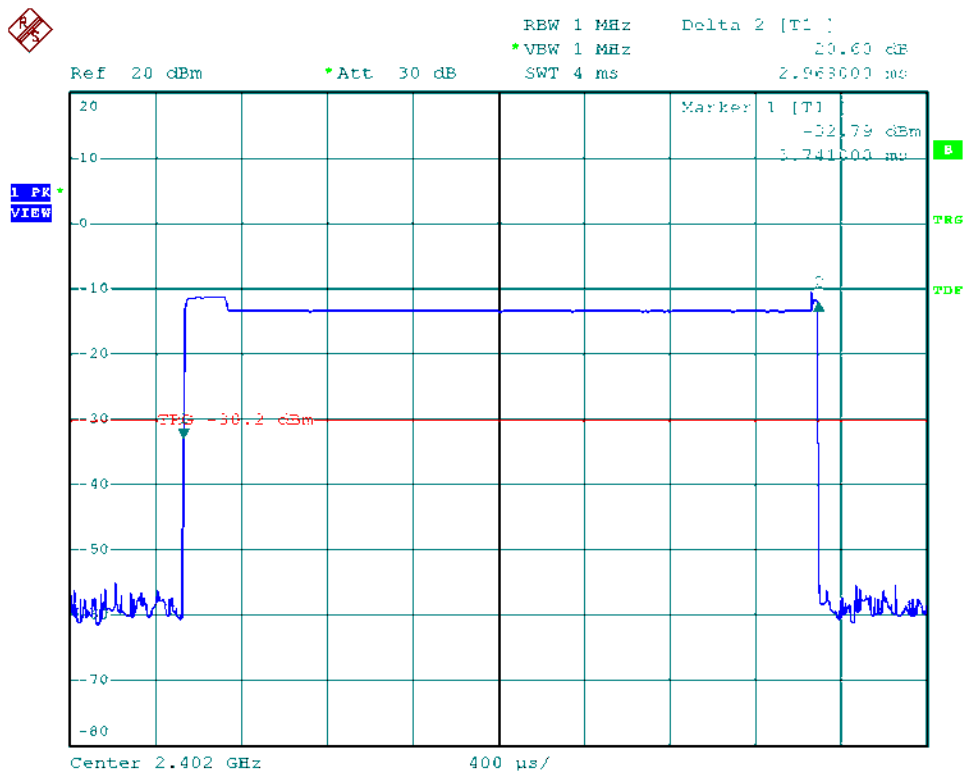



Modulation Standard: $\pi/4$ -DQPSK (2Mbps)
Channel: 39, Rate: 2DH5

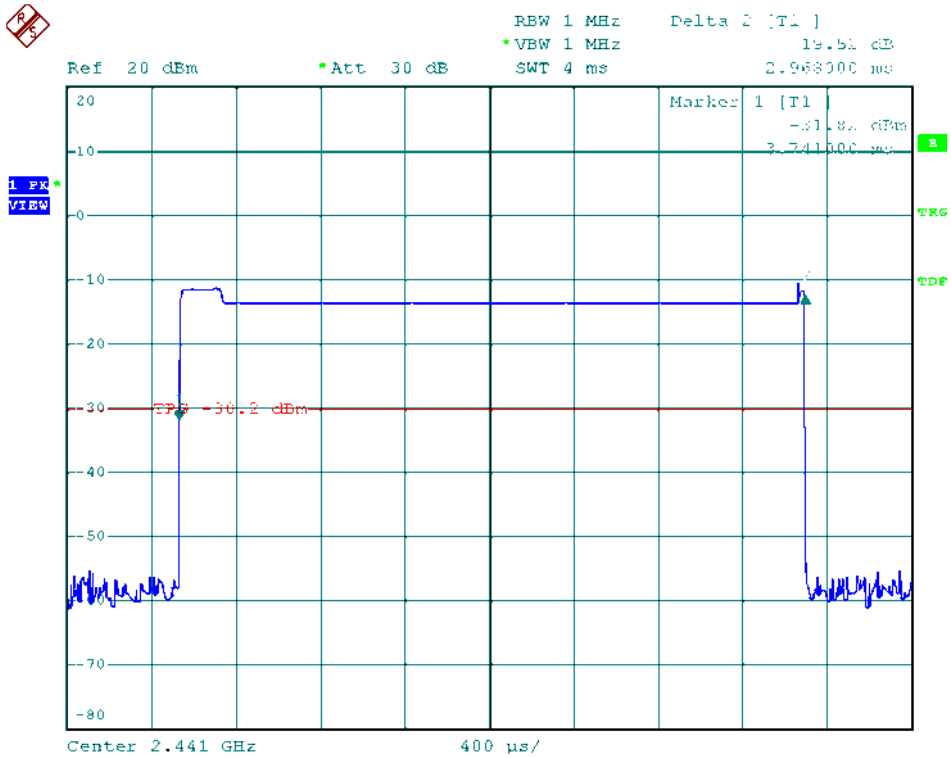

Modulation Standard: $\pi/4$ -DQPSK (2Mbps)
Channel: 78, Rate: 2DH5

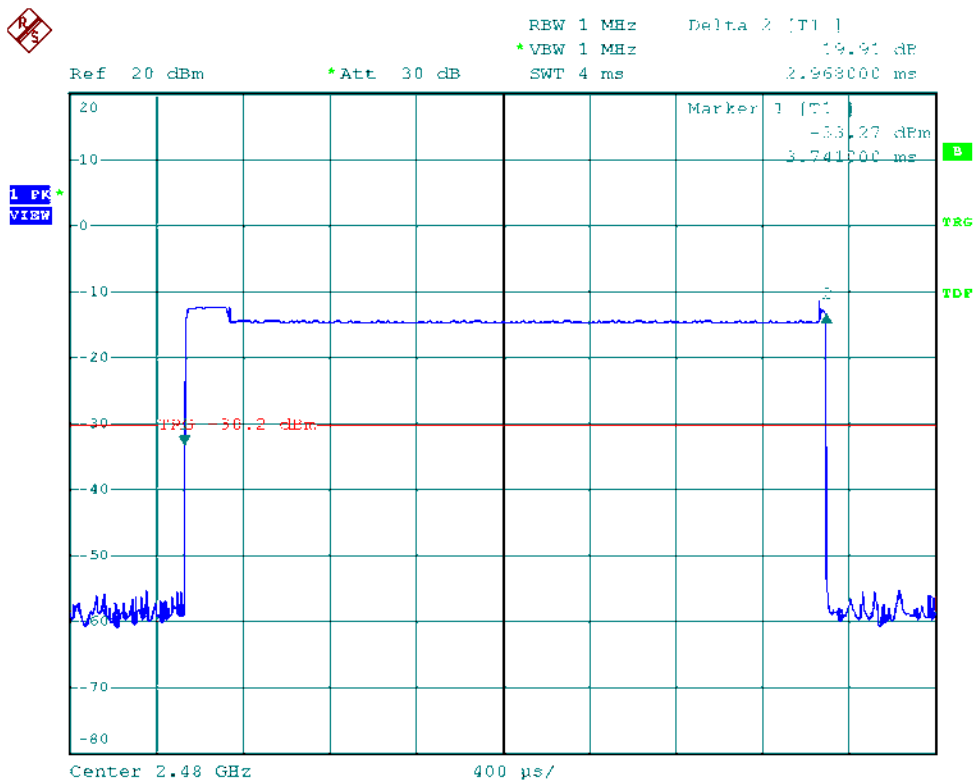



Modulation Standard: 8DPSK (3Mbps)
Channel: 00, Rate: 3DH5

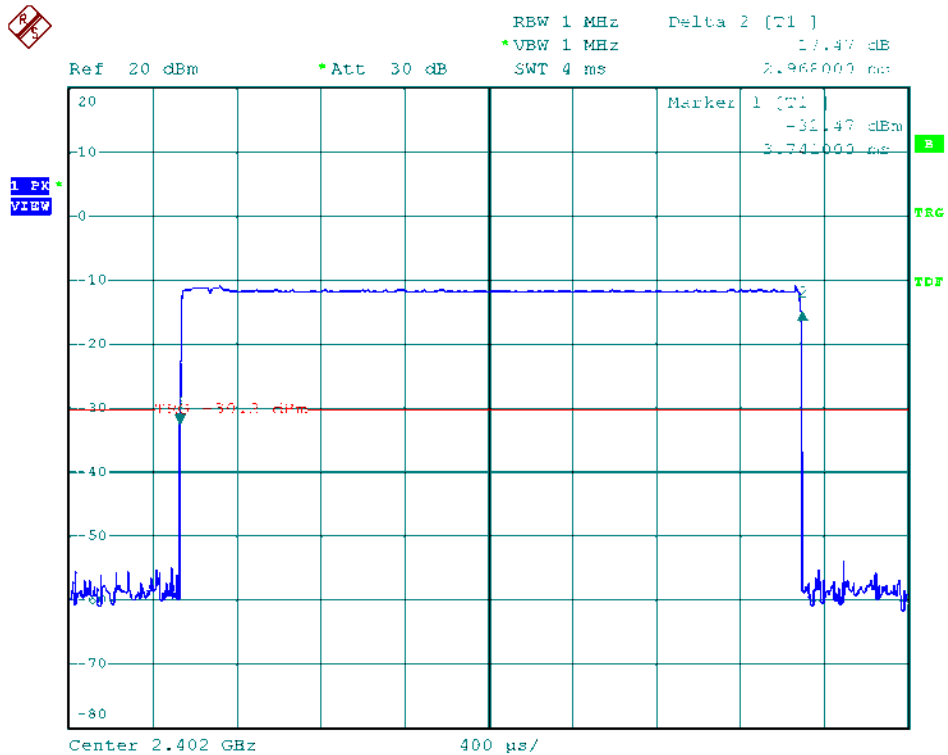

Modulation Standard: 8DPSK (3Mbps)
Channel: 39, Rate: 3DH5

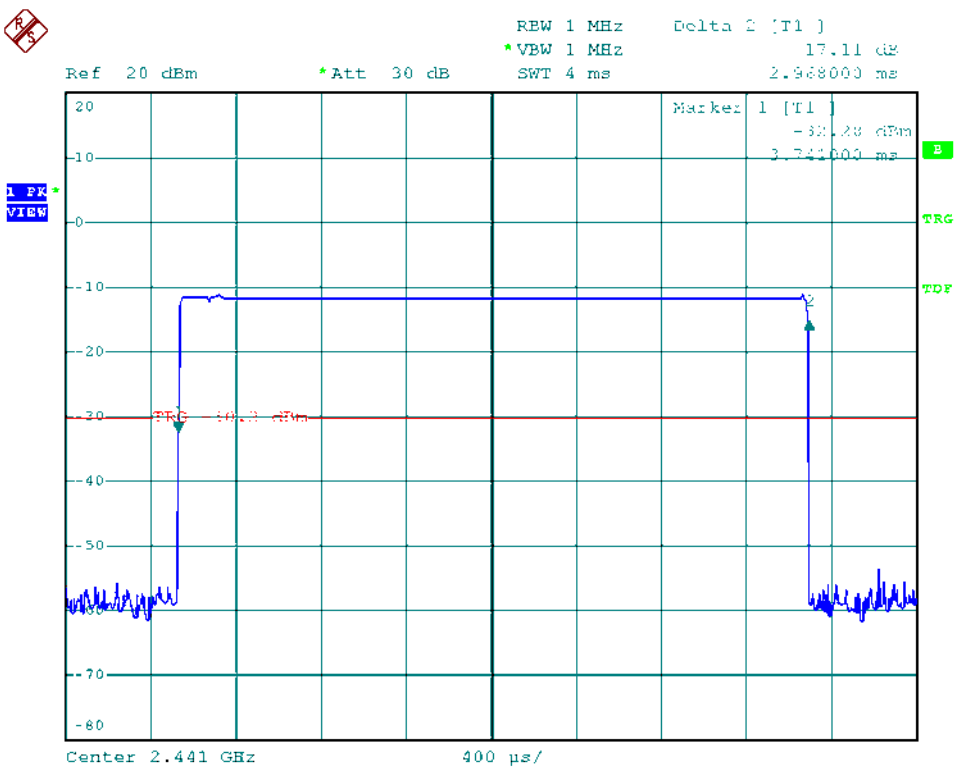



Modulation Standard: 8DPSK (3Mbps)
Channel: 78, Rate: 3DH5

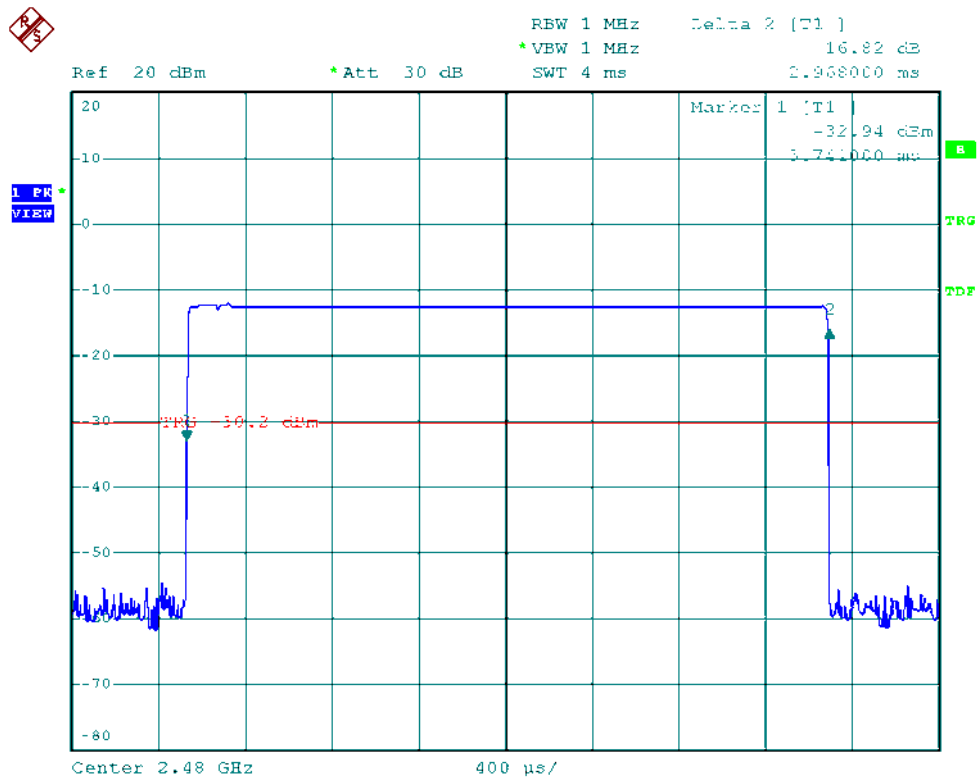



9. Number of Hopping Channels

9.1 Test Limit

Frequency hopping systems in the 2400 ~ 2483.5 MHz band shall use at least 15 channels.

9.2 Test Procedures

- a. The transmitter output was connected to the spectrum analyzer.
- b. 2. Set RBW of spectrum analyzer to 100 KHz and VBW to 100 KHz.
- c. 3. Set the MaxHold function, and then keep the EUT in hopping mode. Record all the signals from each channel until each one has been record.

9.3 Test Setup Layout

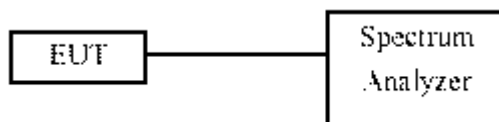

9.4 Measurement equipment

Instrument/Ancillary	Model No.	Manufacturer	Serial No.	Calibration Date	Valid Date
Spectrum Analyzer	R&S	FSP40	100047	2013/03/15	2014/03/14

9.5 Test Result and Data

Test Date: Aug. 09, 2013

Temperature: 25 °C

Atmospheric pressure: 1015 hPa

Humidity: 43 %

Modulation Type	Hopping Channels
GFSK (1Mbps)	79
$\pi/4$ -DQPSK (2Mbps)	79
8DPSK (3Mbps)	79



Modulation Standard: GFSK (1Mbps)

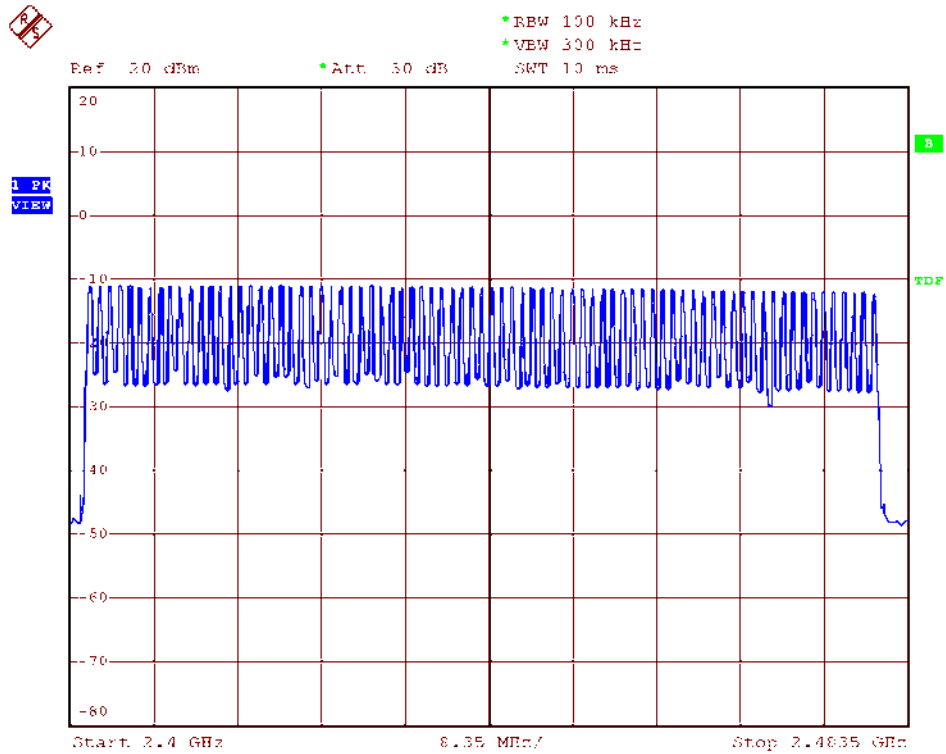

Modulation Standard: $\pi/4$ -DQPSK (2Mbps)

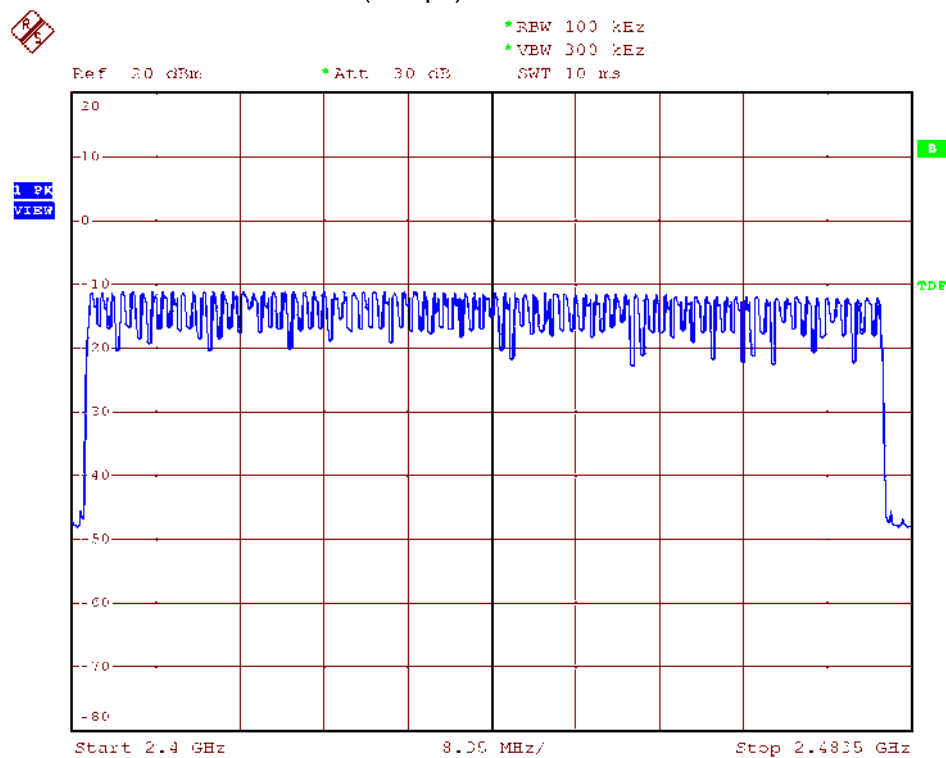



Modulation Standard: 8DPSK (3Mbps)

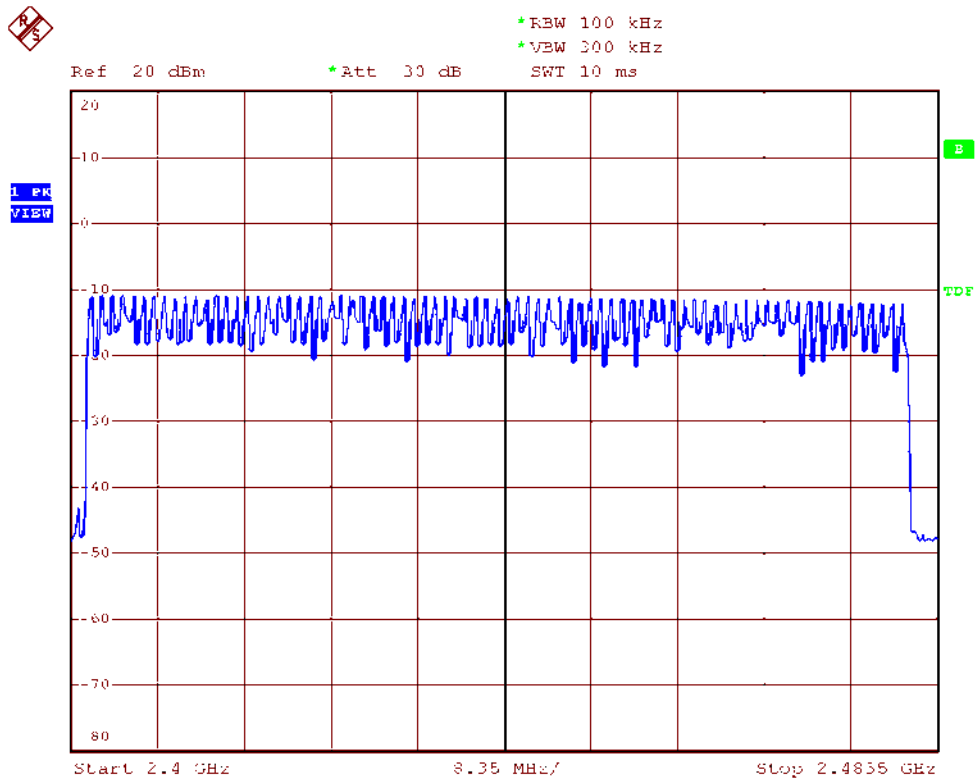



10. Maximum Peak Output Power

10.1 Test Limit

The Maximum Peak Output Power Measurement is 30dBm.

10.2 Test Procedures

The antenna port(RF output)of the EUT was connected to the input(RF input)of a power meter. Power was read directly from the meter and cable loss connection was added to the reading to obtain power at the EUT antenna terminal. The EUT Output Power was set to maximum to produce the worse case test result.

10.3 Test Setup Layout

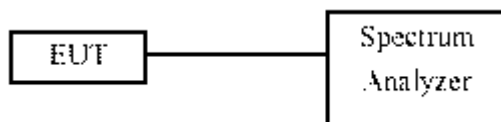

10.4 Measurement equipment

Instrument/Ancillary	Model No.	Manufacturer	Serial No.	Calibration Date	Valid Date
Spectrum Analyzer	R&S	FSP40	100047	2013/03/15	2014/03/14



10.5 Test Result and Data

Test Date: Aug. 09, 2013

Temperature: 25°C

Atmospheric pressure: 1015 hPa

Humidity: 43%

Modulation Type	Channel	Frequency (MHz)	Output Power (dBm)	Output Power (mW)
GFSK (1Mbps)	00	2402	-10.96	0.08
	39	2441	-11.04	0.08
	78	2480	-11.97	0.06
$\pi/4$ -DQPSK (2Mbps)	00	2402	-9.63	0.11
	39	2441	-9.65	0.11
	78	2480	-10.54	0.09
8DPSK (3Mbps)	00	2402	-9.97	0.10
	39	2441	-10.07	0.10
	78	2480	-10.90	0.08



Modulation Standard: GFSK (1Mbps)
Channel: 00

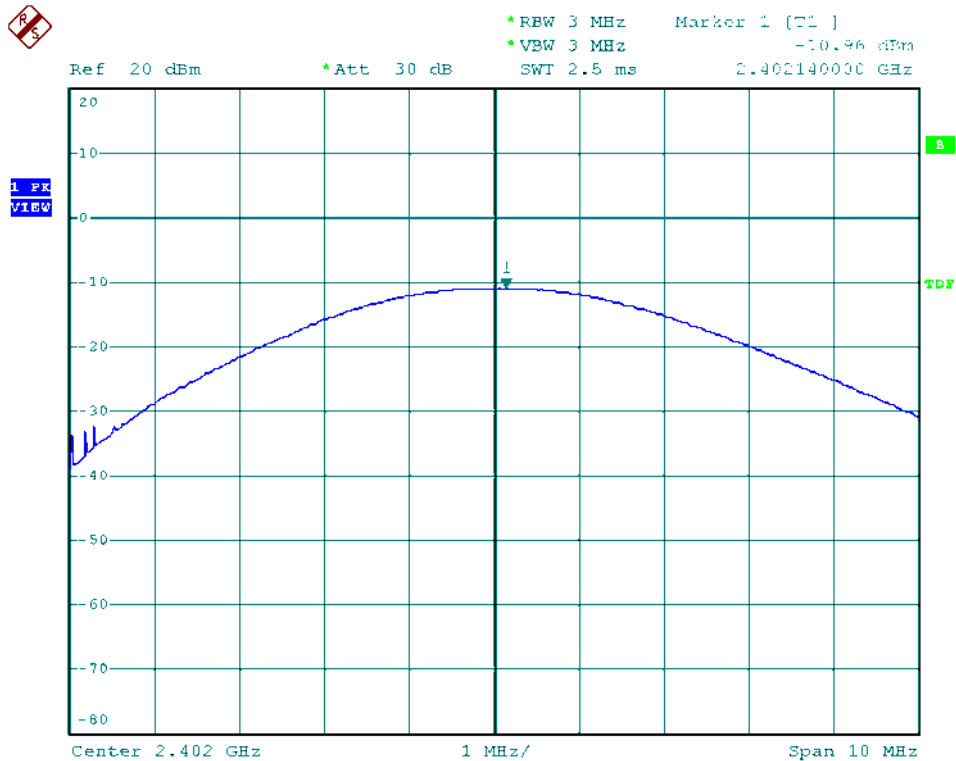

Modulation Standard: GFSK (1Mbps)
Channel: 39

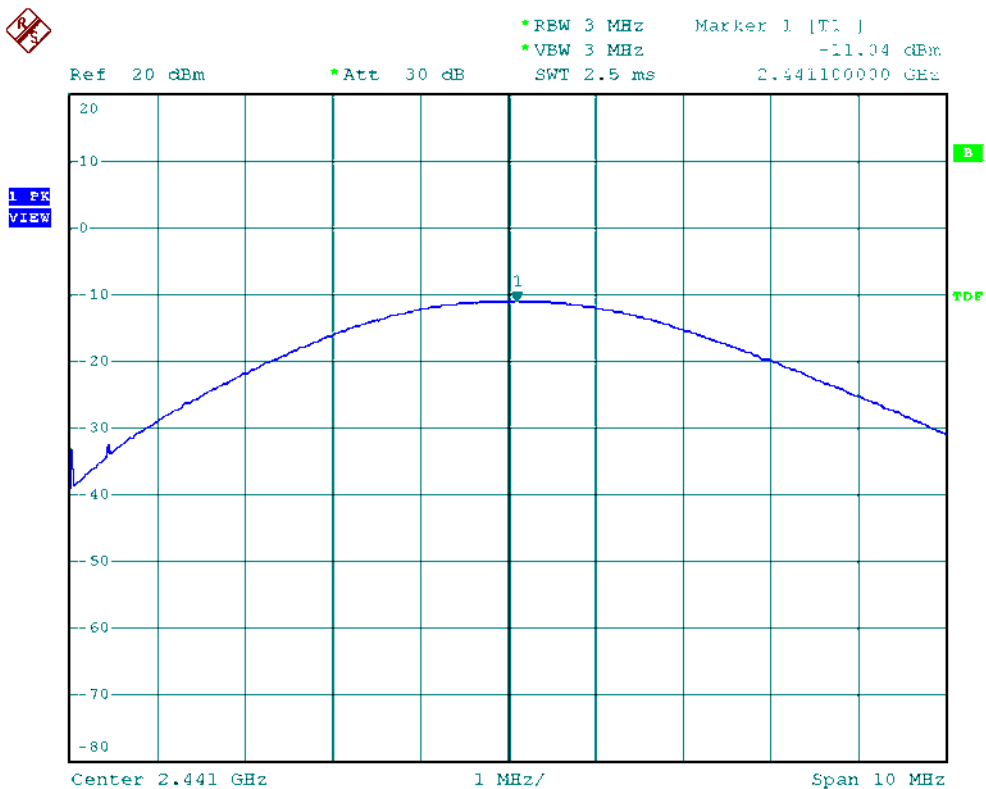



Modulation Standard: GFSK (1Mbps)
Channel: 78

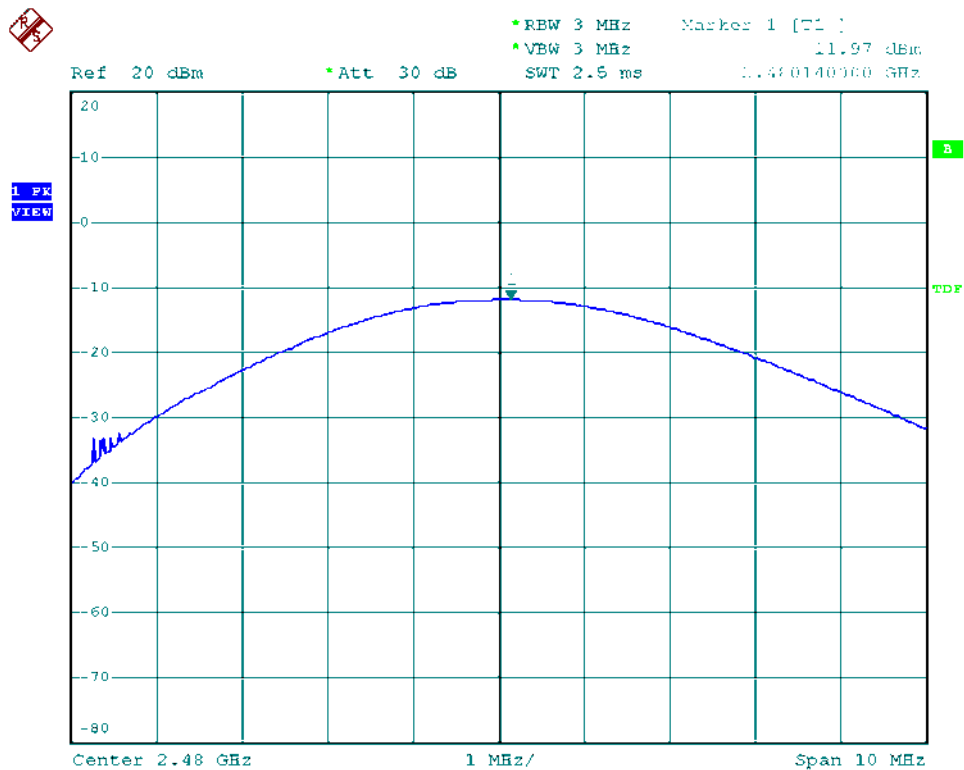

Modulation Standard: $\pi/4$ -DQPSK (2Mbps)
Channel: 00

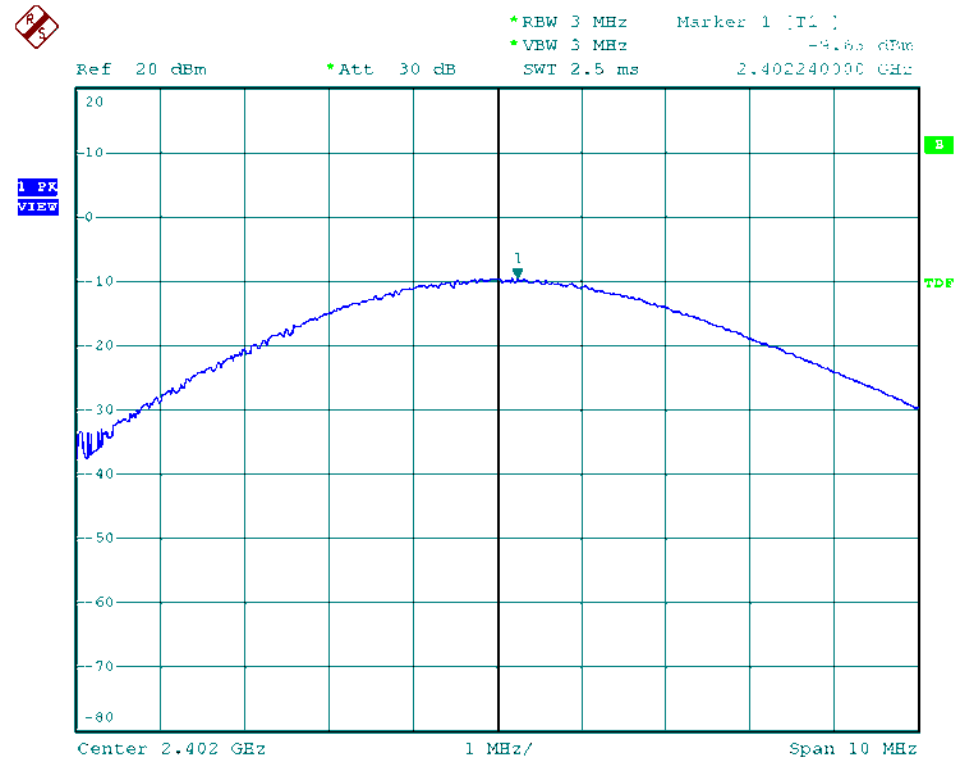



Modulation Standard: $\pi/4$ -DQPSK (2Mbps)
Channel: 39

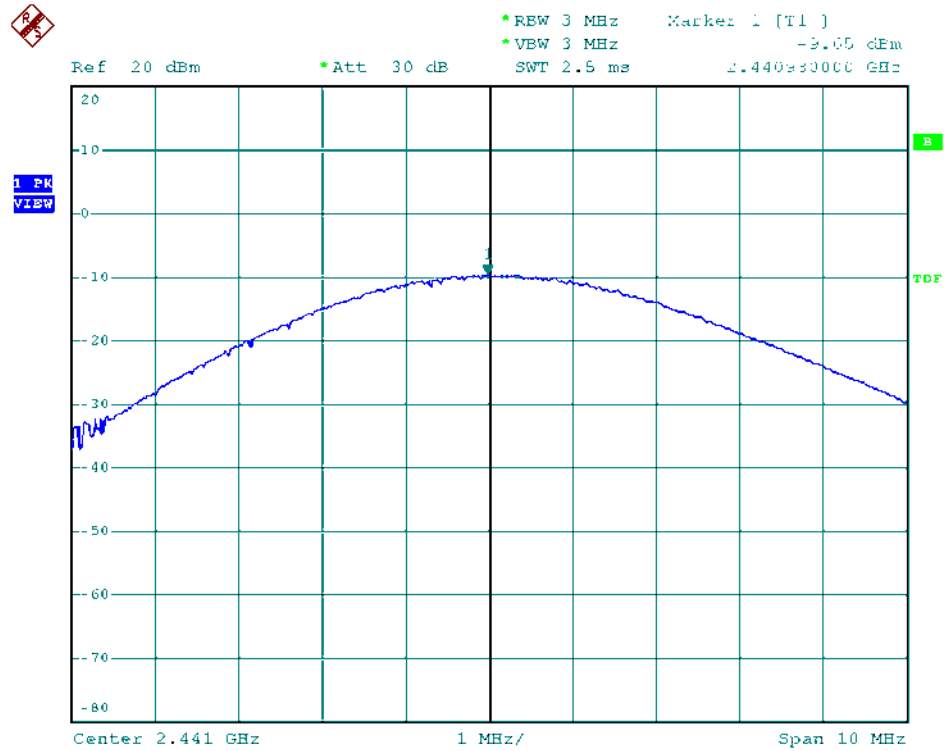

Modulation Standard: $\pi/4$ -DQPSK (2Mbps)
Channel: 78

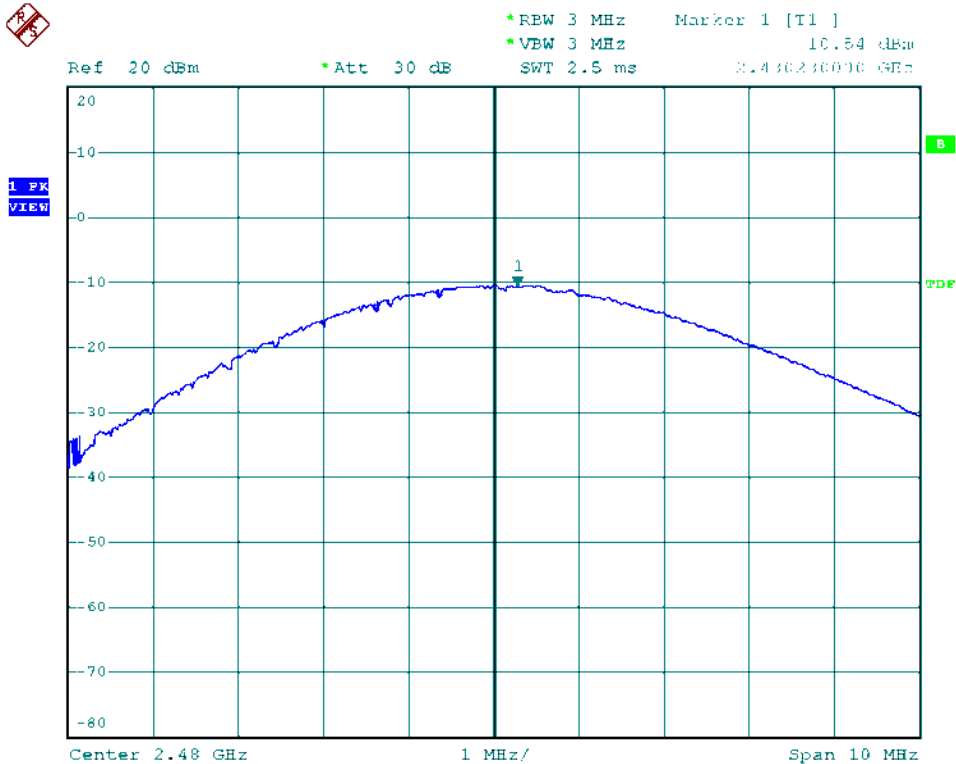



Modulation Standard: 8DPSK (3Mbps)
Channel: 00

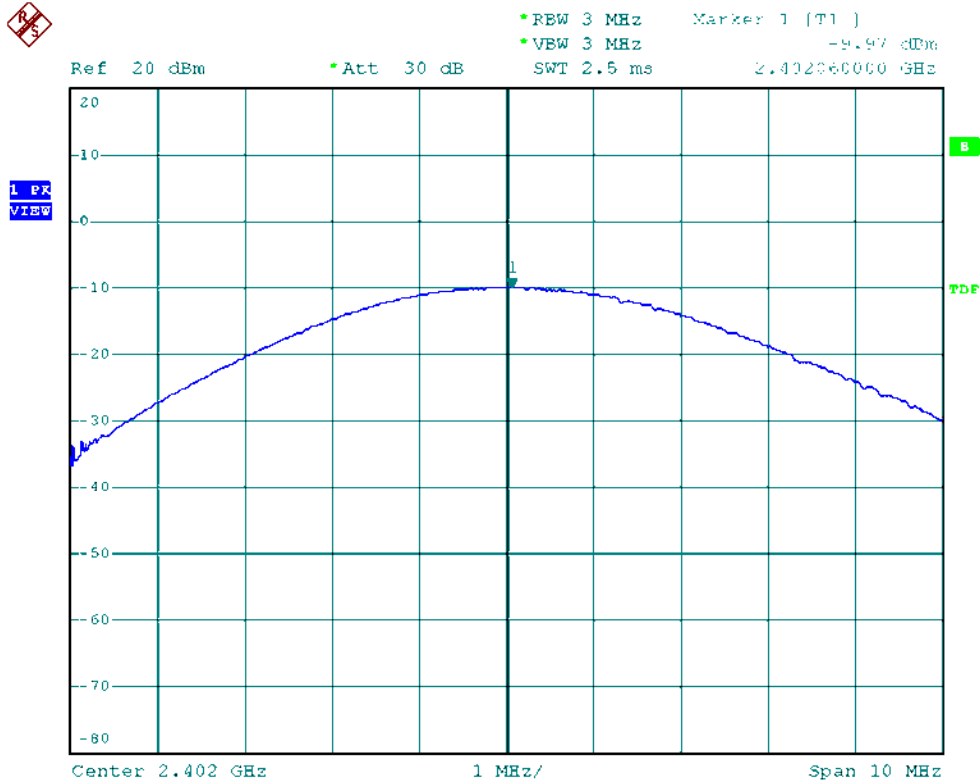

Modulation Standard: 8DPSK (3Mbps)
Channel: 39

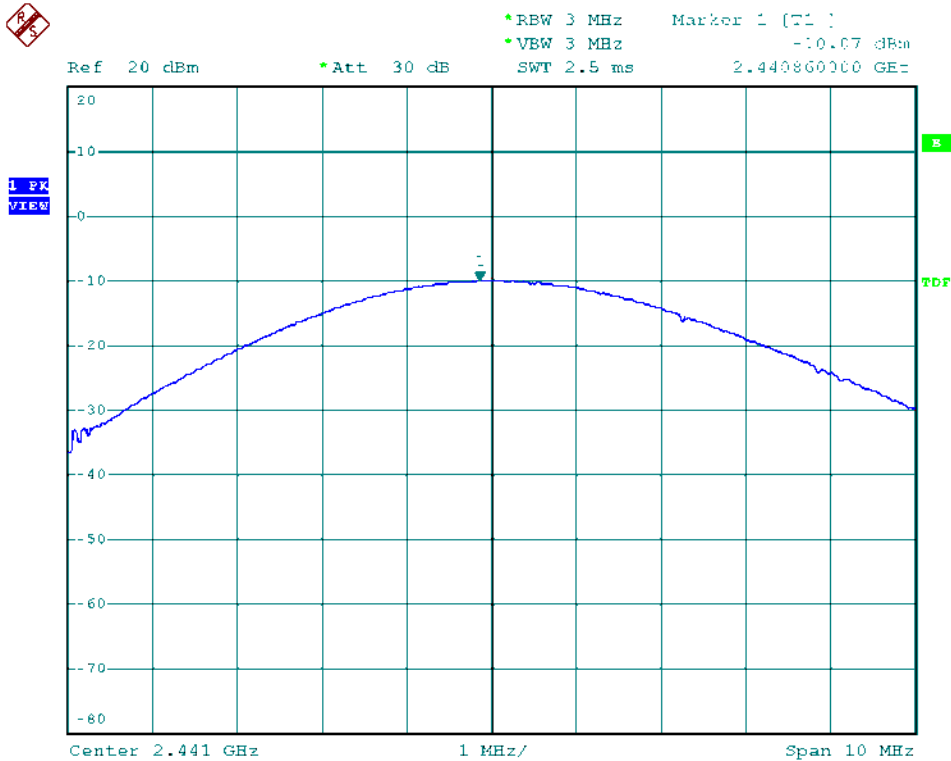



Modulation Standard: 8DPSK (3Mbps)
Channel: 78

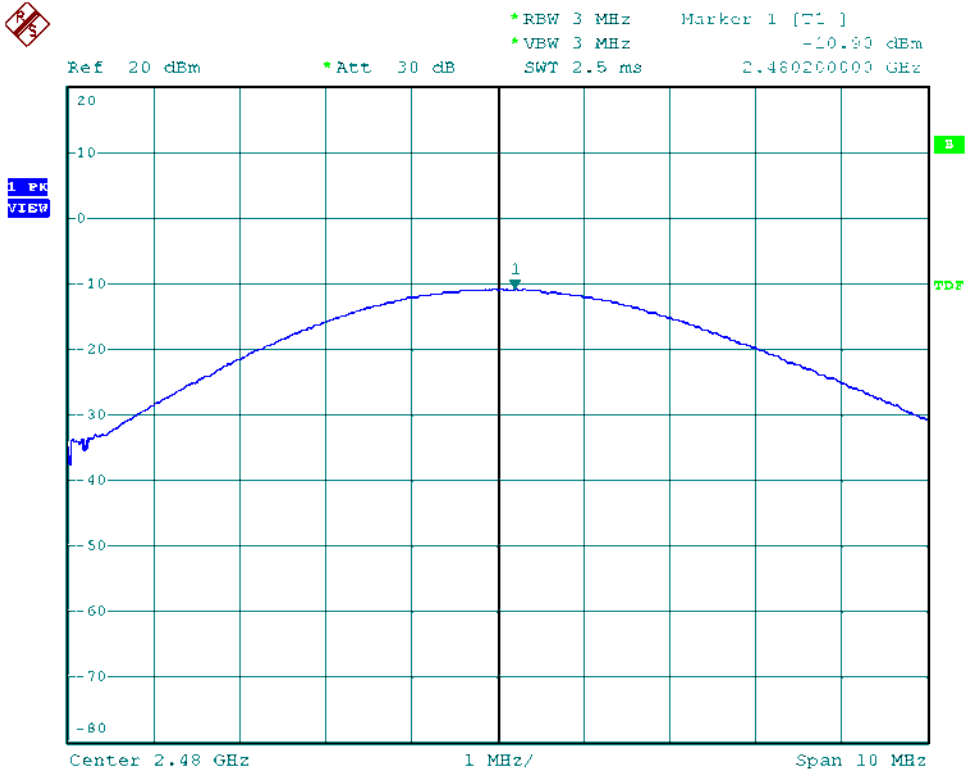



11. Band Edges Measurement

11.1 Test Limit

Below -20dB of the highest emission level of operating band (in 100kHz Resolution Bandwidth).

11.2 Test Procedure

- The transmitter output was connected to the spectrum analyzer via a low lose cable.
- Set both RBW and VBW of spectrum analyzer to 100 KHz with convenient frequency span including 100 KHz bandwidth from band edge.
- The band edges was measured and recorded.

11.3 Test Setup Layout

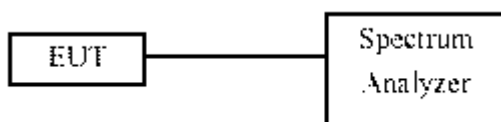

11.4 List of Measuring Equipment Used

Instrument/Ancillary	Model No.	Manufacturer	Serial No.	Calibration Date	Valid Date
Spectrum Analyzer	R&S	FSP40	100047	2013/03/15	2014/03/14

11.5 Test Result and Data

Test Date: Aug. 09, 2013

Temperature: 25 °C

Atmospheric pressure: 1015 hPa

Humidity: 43 %

Modulation Type	Channel	Frequency	Max. Value in frequency(MHz)	Max. Value (dBm)
GFSK (1Mbps)	00	2402	2399.60	-54.72
	78	2480	2506.10	-56.03
$\pi/4$ -DQPSK (2Mbps)	00	2402	2400.00	-53.38
	78	2480	2501.30	-56.91
8DPSK (3Mbps)	00	2402	2400.00	-42.74
	78	2480	3265.00	-49.83



Modulation Standard: GFSK (1Mbps)
Channel: 00

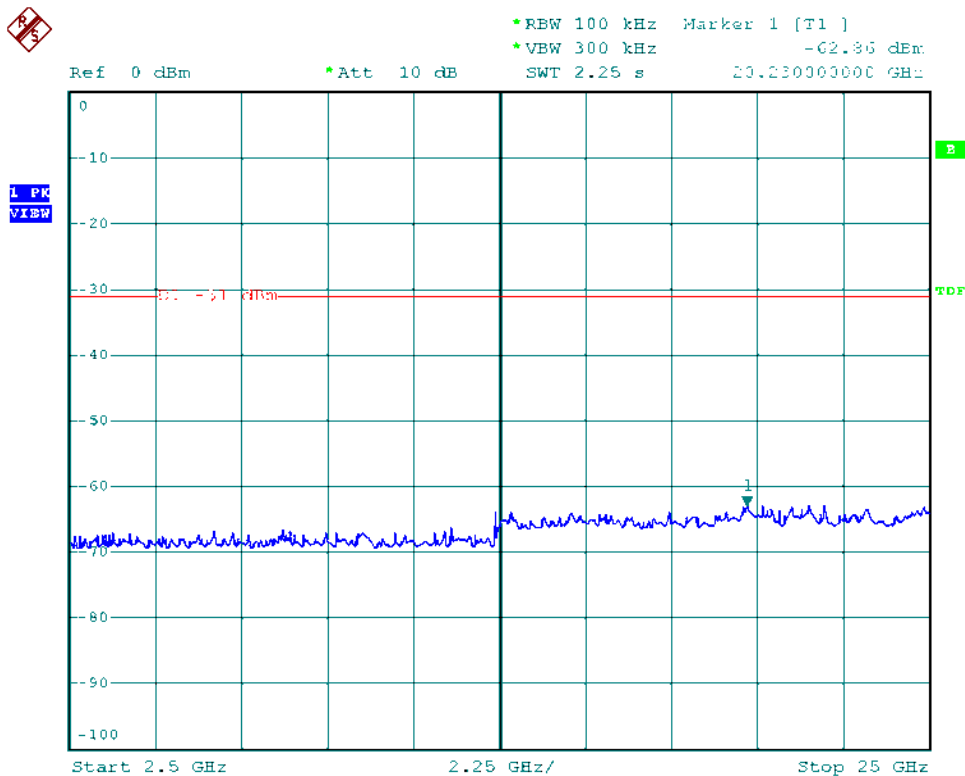
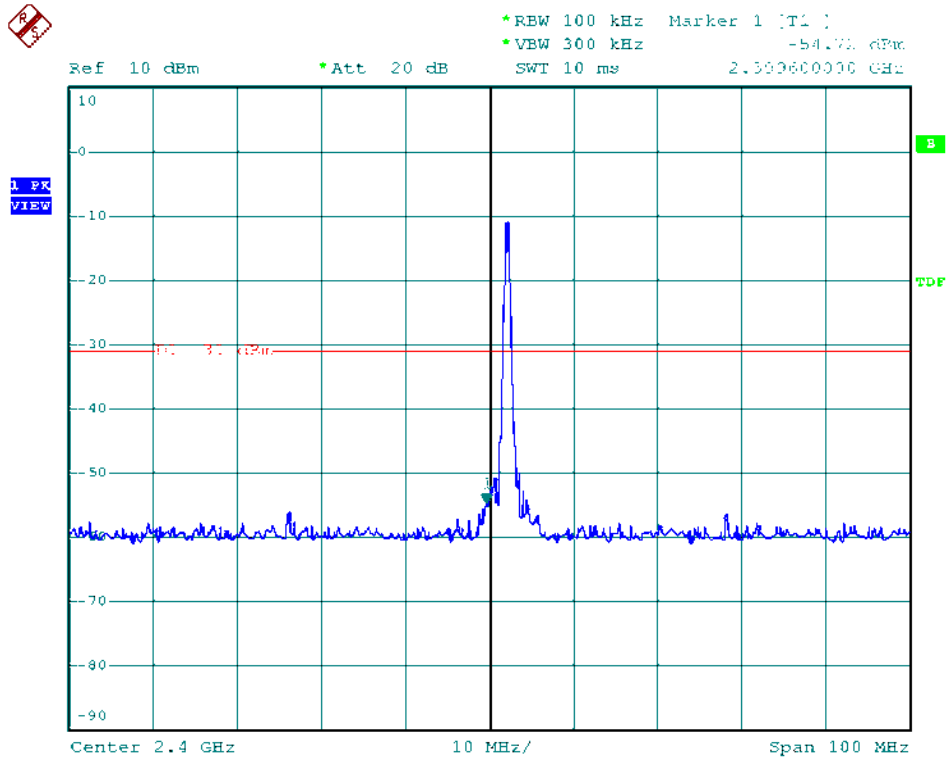



Modulation Standard: GFSK (1Mbps)
Channel: 78

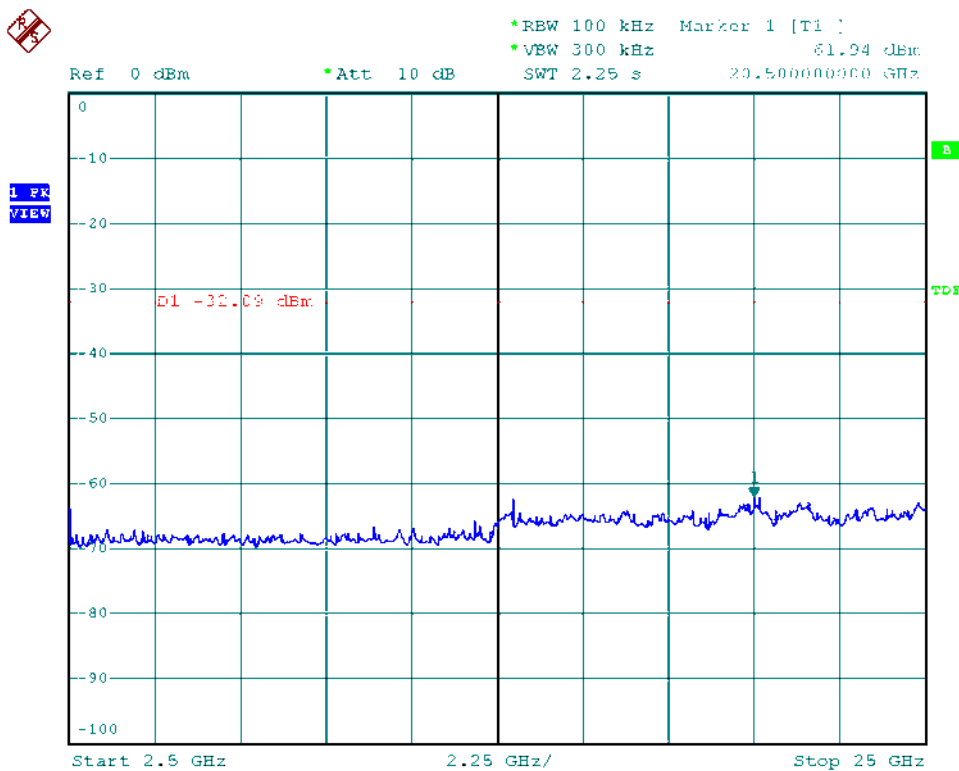
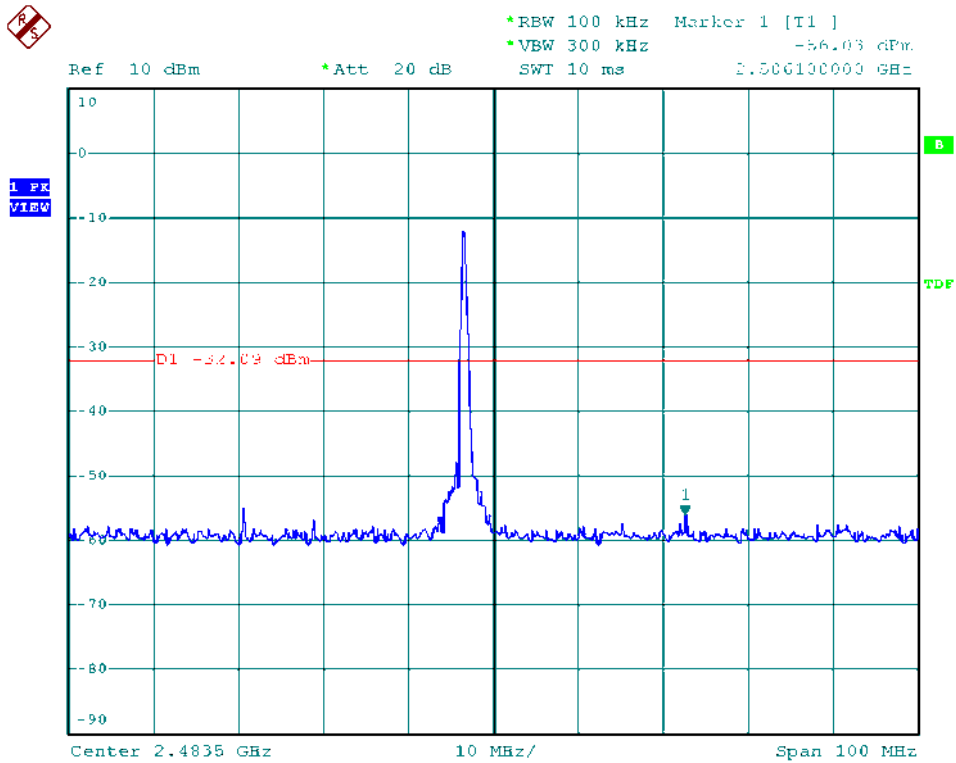



Modulation Standard: $\pi/4$ -DQPSK (2Mbps)
Channel: 00

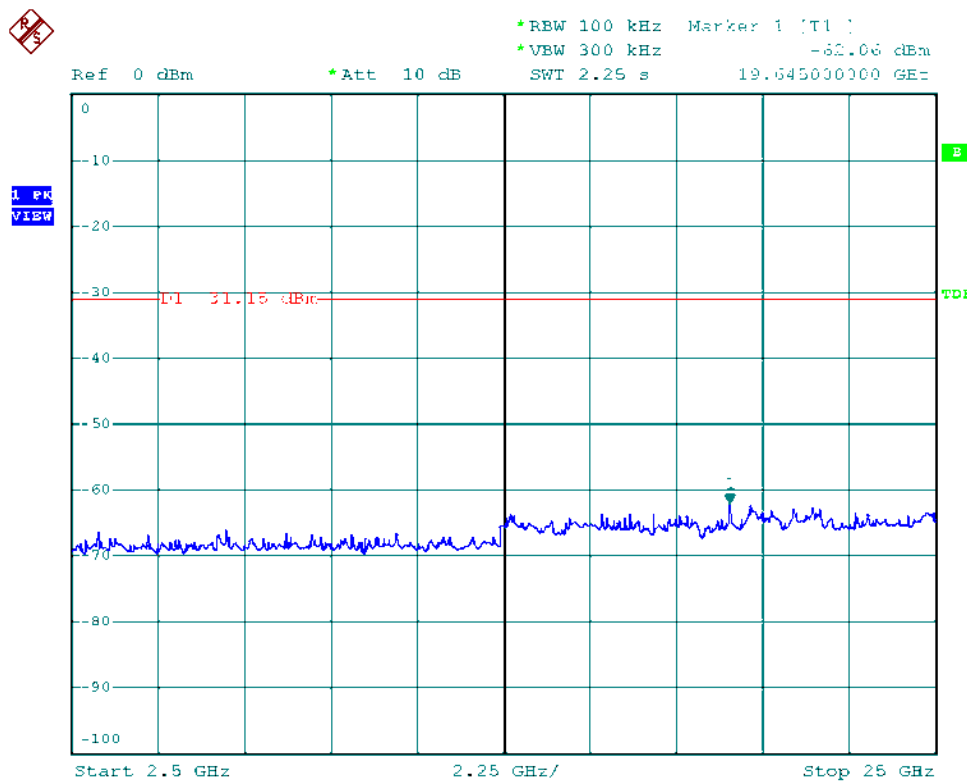
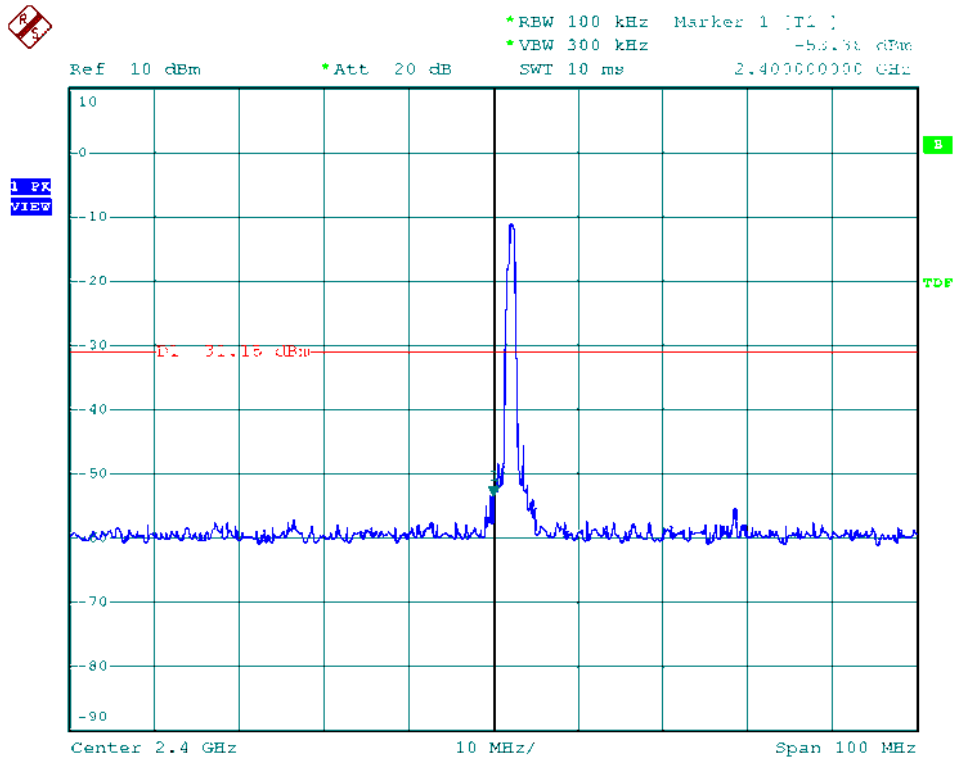



Modulation Standard: $\pi/4$ -DQPSK (2Mbps)
Channel: 78

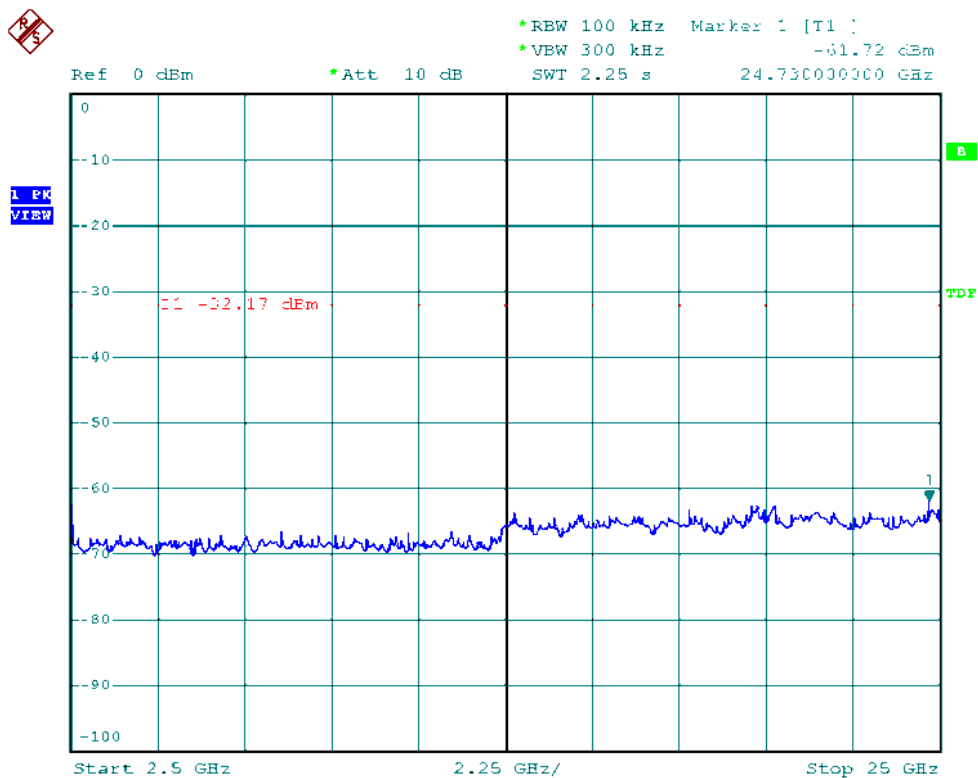
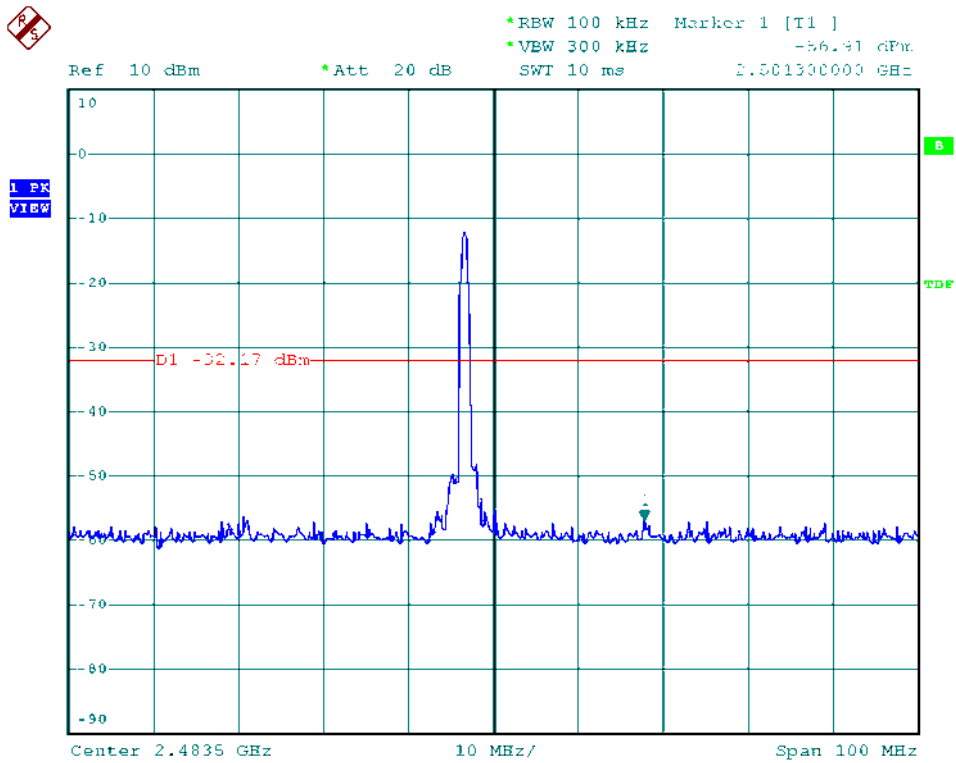



Modulation Standard: 8DPSK (3Mbps)
Channel: 00

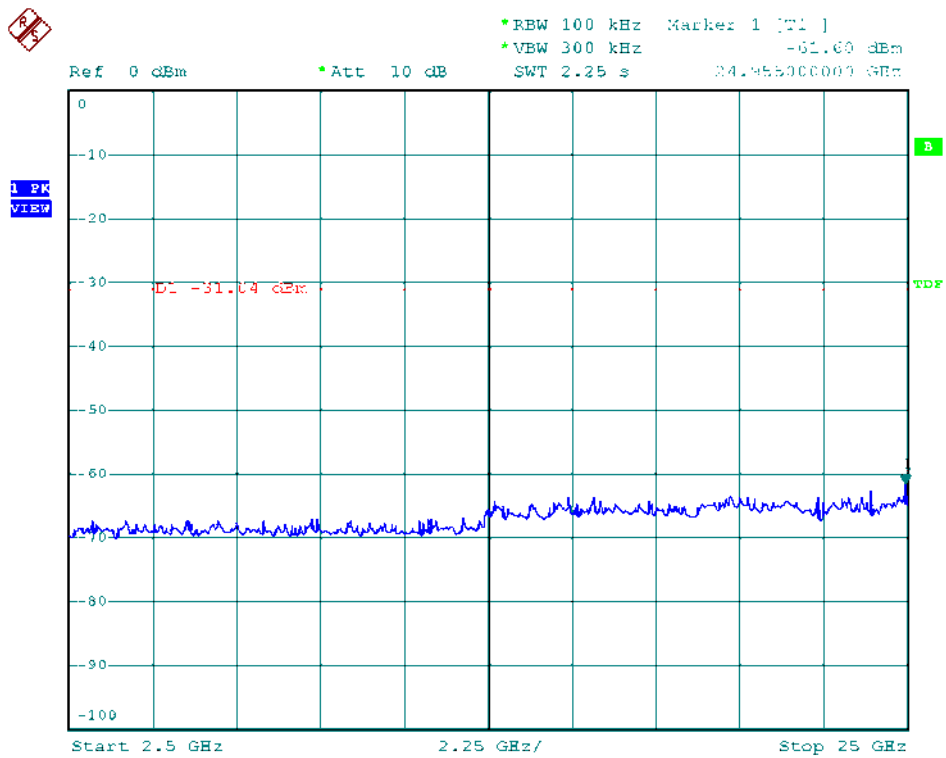
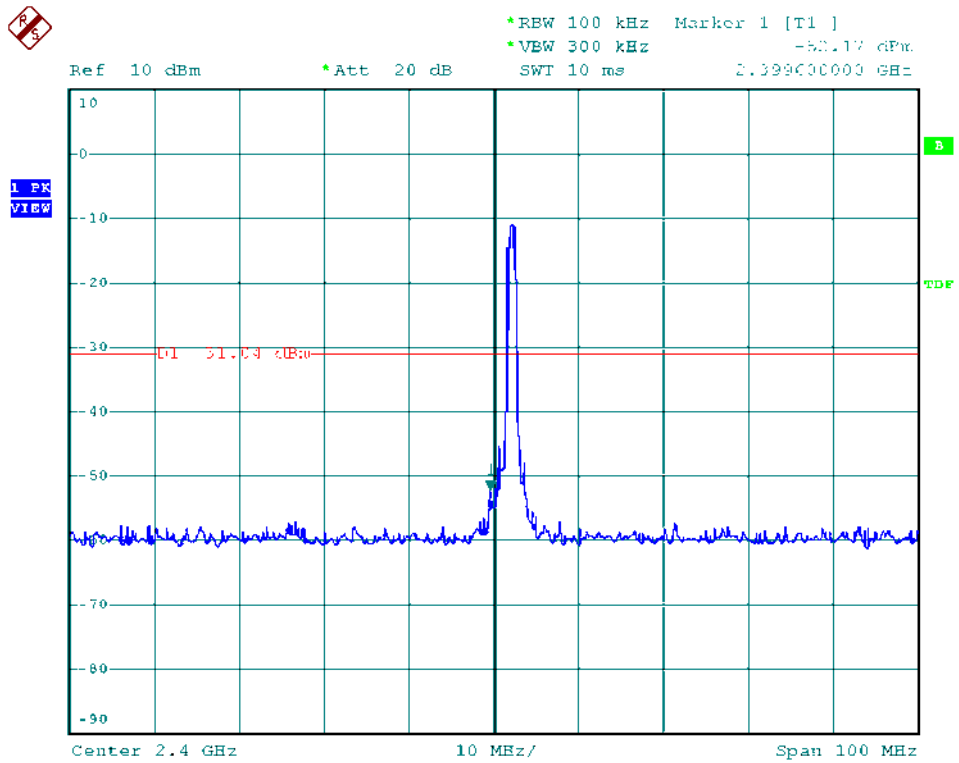



Modulation Standard: 8DPSK (3Mbps)
Channel: 78

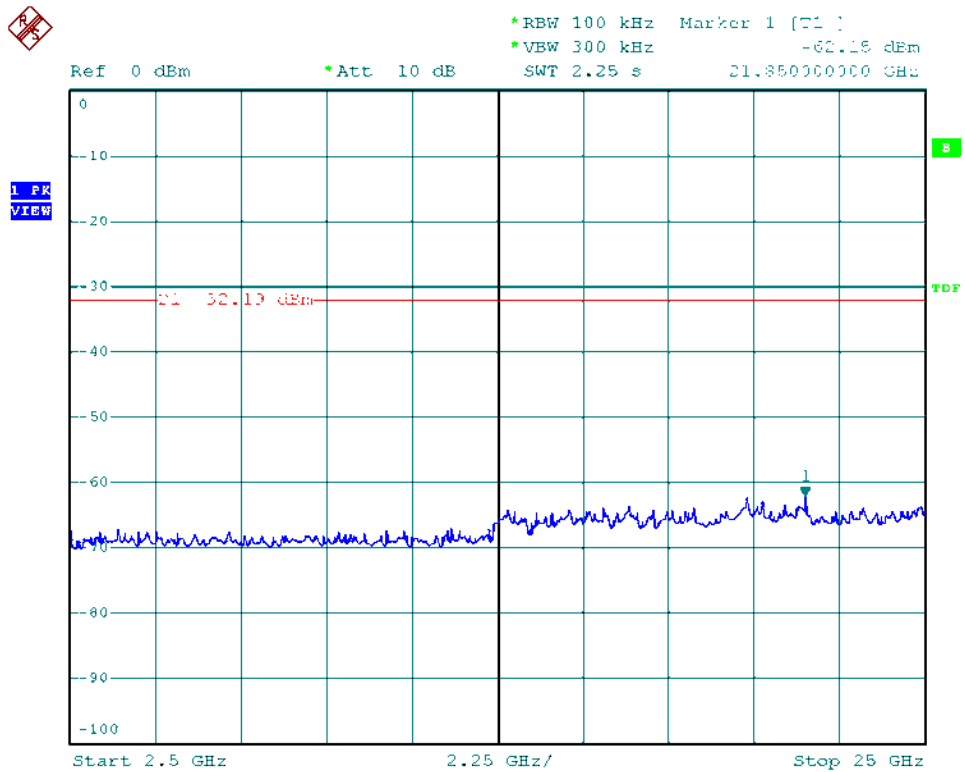
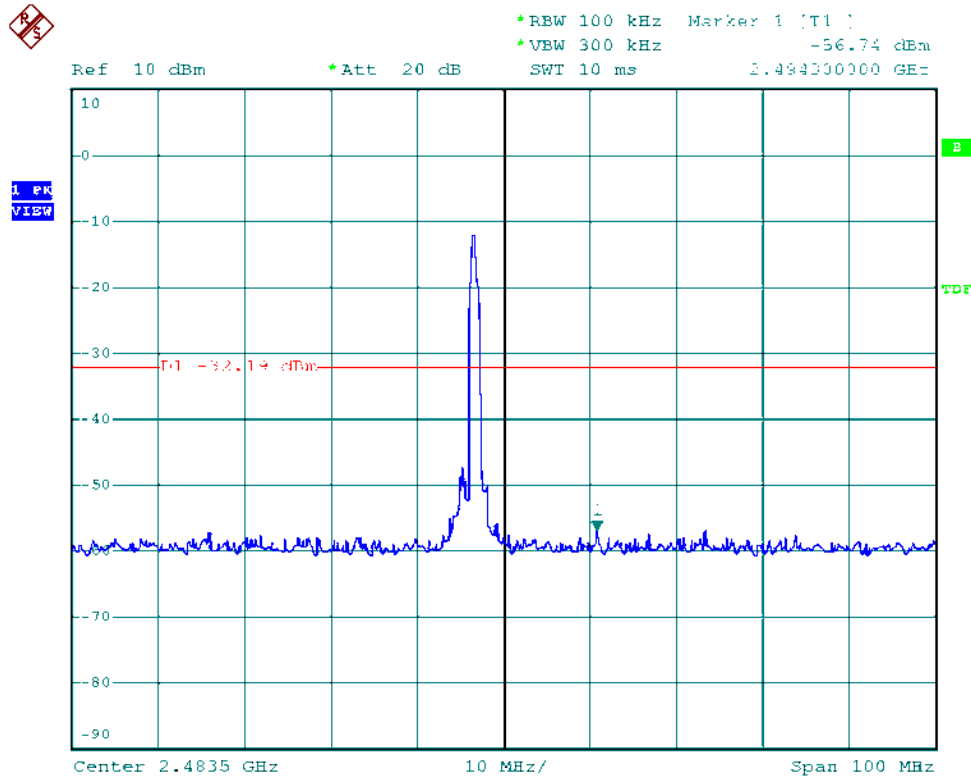

**11.6 Restrict band emission Measurement Data**

Test Date : Aug. 16, 2013
 Temperature : 25 °C
 Humidity : 46 %
 Atmospheric Pressure : 1017 hPa
 Modulation Standard : GFSK (1Mbps)

Channel 0						Fundamental Frequency: 2402 MHz				
Frequency (MHz)	Ant-Pol H/V	Meter Reading	Corrected Factor	Result (dBuV/m)	Remark	Limit@3m (dBuV/m)		Margin (dB)	Table (Deg.)	Ant High (m)
						Peak	Ave.			
2322.09	H	45.41	2.06	47.47	Peak	74	54	-26.53	120	1.00
---	H	---	---	---	Ave	74	54	---	---	---
2312.79	V	45.18	3.69	48.87	Peak	74	54	-25.13	286	1.00
---	V	---	---	---	Ave	74	54	---	---	---
Channel 78						Fundamental Frequency: 2480 MHz				
2489.19	H	45.45	0.41	45.86	Peak	74	54	-28.14	120	1.00
---	H	---	---	---	Ave	74	54	---	---	---
2488.28	V	45.53	-2.40	43.13	Peak	74	54	-30.87	303	1.00
---	V	---	---	---	Ave	74	54	---	---	---

Notes:

1. Result = Meter Reading + Factor
2. Factor = Antenna Factor + Cable Loss – Amplifier
3. The resolution bandwidth of test receiver/spectrum analyzer is 1 MHz and video bandwidth is 3 MHz for Peak detection at frequency above 1GHz.
4. The resolution bandwidth of test receiver/spectrum analyzer is 1MHz and video bandwidth is 10Hz for Average detection at frequency above 1GHz



Test Date : Aug. 16, 2013
 Temperature : 25 °C
 Humidity : 46 %
 Atmospheric Pressure : 1017 hPa
 Modulation Standard : $\pi/4$ -DQPSK (2Mbps)

Channel 0						Fundamental Frequency: 2402 MHz				
Frequency (MHz)	Ant-Pol H/V	Meter Reading	Corrected Factor	Result (dBuV/m)	Remark	Limit@3m (dBuV/m)		Margin (dB)	Table (Deg.)	Ant High (m)
						Peak	Ave.			
2312.98	H	45.36	2.10	47.46	Peak	74	54	-26.54	120	1.00
---	H	---	---	---	Ave	74	54	---	---	---
2319.30	V	45.62	3.58	49.20	Peak	74	54	-24.80	286	1.00
---	V	---	---	---	Ave	74	54	---	---	---
Channel 78						Fundamental Frequency: 2480 MHz				
2484.29	H	45.77	0.48	46.25	Peak	74	54	-27.75	120	1.00
---	H	---	---	---	Ave	74	54	---	---	---
2488.41	V	45.55	-2.41	43.14	Peak	74	54	-30.86	303	1.00
---	V	---	---	---	Ave	74	54	---	---	---

Notes:

1. Result = Meter Reading + Factor
2. Factor = Antenna Factor + Cable Loss – Amplifier
3. The resolution bandwidth of test receiver/spectrum analyzer is 1 MHz and video bandwidth is 3 MHz for Peak detection at frequency above 1GHz.
4. The resolution bandwidth of test receiver/spectrum analyzer is 1MHz and video bandwidth is 10Hz for Average detection at frequency above 1GHz



Test Date : Aug. 16, 2013
 Temperature : 25 °C
 Humidity : 46 %
 Atmospheric Pressure : 1017 hPa
 Modulation Standard : 8DPSK (3Mbps)

Channel 0						Fundamental Frequency: 2402 MHz				
Frequency (MHz)	Ant-Pol H/V	Meter Reading	Corrected Factor	Result (dBuV/m)	Remark	Limit@3m (dBuV/m)		Margin (dB)	Table (Deg.)	Ant High (m)
						Peak	Ave.			
2373.05	H	46.19	1.86	48.05	Peak	74	54	-25.95	120	1.00
---	H	---	---	---	Ave	74	54	---	---	---
2326.93	V	45.51	3.45	48.96	Peak	74	54	-25.04	286	1.00
---	V	---	---	---	Ave	74	54	---	---	---
Channel 78						Fundamental Frequency: 2480 MHz				
2499.06	H	45.51	0.27	45.78	Peak	74	54	-28.22	120	1.00
---	H	---	---	---	Ave	74	54	---	---	---
2487.99	V	45.61	-2.38	43.23	Peak	74	54	-30.77	303	1.00
---	V	---	---	---	Ave	74	54	---	---	---

Notes:

1. Result = Meter Reading + Factor
2. Factor = Antenna Factor + Cable Loss – Amplifier
3. The resolution bandwidth of test receiver/spectrum analyzer is 1 MHz and video bandwidth is 3 MHz for Peak detection at frequency above 1GHz.
4. The resolution bandwidth of test receiver/spectrum analyzer is 1MHz and video bandwidth is 10Hz for Average detection at frequency above 1GHz



12. Restricted Bands of Operation

Only spurious emissions are permitted in any of the frequency bands listed below:

MHz	MHz	MHz	GHz
0.09000 – 0.11000	16.42000 – 16.42300	399.9 – 410.0	4.500 – 5.250
0.49500 – 0.505**	16.69475 – 16.69525	608.0 – 614.0	5.350 – 5.460
2.17350 – 2.19050	16.80425 – 16.80475	960.0 – 1240.0	7.250 – 7.750
4.12500 – 4.12800	25.50000 – 25.67000	1300.0 – 1427.0	8.025 – 8.500
4.17725 – 4.17775	37.50000 – 38.25000	1435.0 – 1626.5	9.000 – 9.200
4.20725 – 4.20775	73.00000 – 74.60000	1645.5 – 1646.5	9.300 – 9.500
6.21500 – 6.21800	74.80000 – 75.20000	1660.0 – 1710.0	10.600 – 12.700
6.26775 – 6.26825	108.00000 – 121.94000	1718.8 – 1722.2	13.250 – 13.400
6.31175 – 6.31225	123.00000 – 138.00000	2200.0 – 2300.0	14.470 – 14.500
8.29100 – 8.29400	149.90000 – 150.05000	2310.0 – 2390.0	15.350 – 16.200
8.36200 – 8.36600	156.52475 – 156.52525	2483.5 – 2500.0	17.700 – 21.400
8.37625 – 8.38675	156.70000 – 156.90000	2655.0 – 2900.0	22.010 – 23.120
8.41425 – 8.41475	162.01250 – 167.17000	3260.0 – 3267.0	23.600 – 24.000
12.29000 – 12.29300	167.72000 – 173.20000	3332.0 – 3339.0	31.200 – 31.800
12.51975 – 12.52025	240.00000 – 285.00000	3345.8 – 3358.0	36.430 – 36.500
12.57675 – 12.57725	322.00000 – 335.40000	3600.0 – 4400.0	Above 38.6
13.36000 – 13.41000			

** : Until February 1, 1999, this restricted band shall be 0.490-0.510 MHz

12.1 Labeling Requirement

The device shall bear the following statement in a conspicuous location on the device:

This device complies with part 15 of the FCC Rules. Operation is subject to the following two conditions: (1) This device may not cause harmful interference, and (2) this device must accept any interference received, including interference that may cause undesired operation.