



BUREAU
VERITAS

Test Report No.: PSU-QSU2312200110RF02



Certificate #6613.01

FCC TEST REPORT (PART 24)

Applicant:	Power Idea Technology (Shenzhen) Co., Ltd.
Address:	4th Floor, A Section, Languang Science&technology Building, No.7 Xinxi RD, Hi-Tech Industrial Park North, Nanshan District, ShenZhen, P.R.C.

Manufacturer or Supplier:	Power Idea Technology (Shenzhen) Co., Ltd.
Address:	4th Floor, A Section, Languang Science&technology Building, No.7 Xinxi RD, Hi-Tech Industrial Park North, Nanshan District, ShenZhen, P.R.C.
Product:	Smart Phone
Brand Name:	RugGear
Model Name:	PSM03G
Marketing name :	RG880
FCC ID:	ZLE-RG880
Date of tests:	Dec. 20, 2023 ~Mar. 20, 2024

The tests have been carried out according to the requirements of the following standard:

- FCC PART 24, Subpart E FCC PART 2
 ANSI/TIA/EIA-603-D ANSI/TIA/EIA-603-E ANSI C63.26-2015

CONCLUSION: The submitted sample was found to COMPLY with the test requirement

Prepared by Hanwen Xu Engineer / Mobile Department	Approved by Peibo Sun Manager / Mobile Department
Date: Mar. 20, 2024	Date: Mar. 20, 2024

This report is governed by, and incorporates by reference, the Conditions of Testing as posted at the date of issuance of this report at <http://www.bureauveritas.com/home/about-us/our-business/cps/about-us/terms-conditions/> and is intended for your exclusive use. Any copying or replication of this report to or for any other person or entity, or use of our name or trademark, is permitted only with our prior written permission. This report sets forth our findings solely with respect to the test samples identified herein. The results set forth in this report are not indicative or representative of the quality or characteristics of the lot from which a test sample was taken or any similar or identical product unless specifically and expressly noted. Our report includes all of the tests requested by you and the results thereof based upon the information that you provided to us. Measurement uncertainty is only provided upon request for accredited tests. Statements of conformity are based on simple acceptance criteria without taking measurement uncertainty into account, unless otherwise requested in writing. You have 60 days from date of issuance of this report to notify us of any material error or omission caused by our negligence or if you require measurement uncertainty; provided, however, that such notice shall be in writing and shall specifically address the issue you wish to raise. A failure to raise such issue within the prescribed time shall constitute your unqualified acceptance of the completeness of this report, the tests conducted and the correctness of the report contents.

TABLE OF CONTENTS

RELEASE CONTROL RECORD	5
1 SUMMARY OF TEST RESULTS	6
1.1 MEASUREMENT UNCERTAINTY	7
1.2 TEST SITE AND INSTRUMENTS	8
2 GENERAL INFORMATION	11
2.1 GENERAL DESCRIPTION OF EUT	11
2.2 CONFIGURATION OF SYSTEM UNDER TEST	15
2.3 DESCRIPTION OF SUPPORT UNITS	16
2.4 TEST ITEM AND TEST CONFIGURATION.....	16
2.5 EUT OPERATING CONDITIONS	20
2.6 GENERAL DESCRIPTION OF APPLIED STANDARDS	20
3 TEST TYPES AND RESULTS	21
3.1 OUTPUT POWER MEASUREMENT	21
3.1.1 LIMITS OF OUTPUT POWER MEASUREMENT	21
3.1.2 TEST PROCEDURES	21
3.1.3 TEST SETUP	22
3.1.4 TEST RESULTS	22
3.2 FREQUENCY STABILITY MEASUREMENT	37
3.2.1 LIMITS OF FREQUENCY STABILITY MEASUREMENT	37
3.2.2 TEST PROCEDURE	37
3.2.3 TEST SETUP	37
3.2.4 TEST RESULTS	38
3.3 OCCUPIED BANDWIDTH MEASUREMENT	39
3.3.1 LIMITS OF OCCUPIED BANDWIDTH MEASUREMENT	39
3.3.2 TEST SETUP	39
3.3.3 TEST PROCEDURES	39
3.3.4 TEST RESULTS	40
3.4 BAND EDGE MEASUREMENTC	41
3.4.1 LIMITS OF BAND EDGE MEASUREMENT	41
3.4.2 TEST SETUP	41
3.4.3 TEST PROCEDURES	42
3.4.4. TEST RESULTS	43
3.5 CONDUCTED SPURIOUS EMISSIONS.....	44
3.5.1 LIMITS OF CONDUCTED SPURIOUS EMISSIONS MEASUREMENT	44
3.5.2 TEST PROCEDURE	44
3.5.3 TEST SETUP	44
3.5.4 TEST RESULTS	45
3.6 RADIATED EMISSION MEASUREMENT	46
3.6.1 LIMITS OF RADIATED EMISSION MEASUREMENT	46
3.6.2 TEST PROCEDURES.....	46
3.6.3 DEVIATION FROM TEST STANDARD.....	46



3.6.4 TEST SETUP	47
3.6.5 TEST RESULTS	49
3.7 PEAK TO AVERAGE RATIO	91
3.7.1 LIMITS OF PEAK TO AVERAGE RATIO MEASUREMENT	91
3.7.2 TEST SETUP	91
3.7.3 TEST PROCEDURES	91
3.7.4 TEST RESULTS	92
4 INFORMATION ON THE TESTING LABORATORIES	93
5 MODIFICATIONS RECORDERS FOR ENGINEERING CHANGES TO THE EUT BY THE LAB.....	94
6 APPENDIX	95
GSM 1900	95
PEAK-TO-AVERAGE RATIO(CCDF).....	95
TEST RESULT	95
TEST GRAPHS	96
26DB BANDWIDTH AND OCCUPIED BANDWIDTH	99
TEST RESULT	99
TEST GRAPHS	100
BAND EDGE	103
TEST RESULT	103
TEST GRAPHS	104
CONDUCTED SPURIOUS EMISSION.....	106
TEST RESULT	106
TEST GRAPHS	107
FREQUENCY STABILITY	110
TEST RESULT	110
CDMA2000 BC1.....	112
PEAK-TO-AVERAGE RATIO(CCDF).....	112
TEST RESULT	112
TEST GRAPHS	113
26DB BANDWIDTH AND OCCUPIED BANDWIDTH	114
TEST RESULT	114
TEST GRAPHS	115
BAND EDGE	116
TEST RESULT	116
TEST GRAPHS	117
CONDUCTED SPURIOUS EMISSION.....	118
TEST RESULT	118
TEST GRAPHS	119
FREQUENCY STABILITY	120
TEST RESULT	120
WCDMA BAND2	121
PEAK-TO-AVERAGE RATIO	121
TEST RESULT	121
TEST GRAPHS	122
26DB BANDWIDTH AND OCCUPIED BANDWIDTH	124



Test Report No.: PSU-QSU2312200110RF02

TEST RESULT 124
TEST GRAPHS 125

BAND EDGE 127
TEST RESULT 127
TEST GRAPHS 128

CONDUCTED SPURIOUS EMISSION 129
TEST RESULT 129
TEST GRAPHS 130

FREQUENCY STABILITY 132
TEST RESULT 132

LTE BAND 2 133

PEAK-TO-AVERAGE RATIO(CCDF) 133
TEST RESULT 133
TEST GRAPHS 134

26DB BANDWIDTH AND OCCUPIED BANDWIDTH 143
TEST RESULT 143
TEST GRAPHS 145

BAND EDGE 173
TEST RESULT 173
TEST GRAPHS 175

CONDUCTED SPURIOUS EMISSION 212
TEST RESULT 212
TEST GRAPHS 214

FREQUENCY STABILITY 241
TEST RESULT 241



BUREAU
VERITAS

Test Report No.: PSU-QSU2312200110RF02

RELEASE CONTROL RECORD

ISSUE NO.	REASON FOR CHANGE	DATE ISSUED
PSU-QSU2312200110RF02	Original release	Mar. 20, 2024



1 SUMMARY OF TEST RESULTS

The EUT has been tested according to the following specifications:

APPLIED STANDARD: FCC Part 24 & Part 2			
STANDARD SECTION	TEST TYPE	RESULT	Test lab*
§2.1046	Coducted Output Power	Compliance	A
§24.232(c)	Equivalent Isotropic Radiated Power	Compliance	A
§2.1055 §24.235	Frequency Stability	Compliance	A/B
§2.1049 §24.238(b)	Occupied Bandwidth	Compliance	A/B
§24.232(d)	Peak to average ratio*	Compliance	A/B
§2.1051 §24.238(a)(b)	Band Edge Measurements	Compliance	A/B
§2.1051 §24.238(a)(b)	Conducted Spurious Emissions	Compliance	A/B
§2.1053 §24.238(a)(b)	Radiated Spurious Emissions	Compliance	A/B

* Refer to KDB 971168 D01 Power Meas License Digital Systems v03r01.

NOTE: The maximum RF output power level is 1xRTT RC3 SO55 mode for CDMA2000 BC1, so only 1xRTT mode was used for all tests.

*Test Lab Information Reference

Lab A:

Huarui 7Layers High Technology (Suzhou) Co., Ltd.

Lab Address:

Tower N, Innovation Center, 88 Zhuyi Road, High-tech District, Suzhou City, Anhui Province

Accredited Test Lab Cert 6613.01

The FCC Site Registration No. is 434559; The Designation No. is CN1325.

Lab B:

BV 7Layers Communications Technology (Shenzhen) Co. Ltd

Lab Address:

Room B37, Warehouse A5, No.3 Chiwan 4th Road, Zhaoshang Street, Nanshan District

Shenzhen, Guangdong, People's Republic of China

Accredited Test Lab Cert 3939.01

The FCC Site Registration No. is 525120; The Designation No. is CN1171.

Huarui 7layers High Technology
(Suzhou) Co., Ltd.

Tower N, Innovation Center, 88 Zhuyi Road,
High-tech District, Suzhou City, Anhui Province

Tel: +86 (0557) 368 1008



1.1 MEASUREMENT UNCERTAINTY

Where relevant, the following measurement uncertainty levels have been estimated for tests performed on the EUT as specified in CISPR 16-4-2:

MEASUREMENT	UNCERTAINTY
Frequency Stability	± 76.97Hz
Radiated emissions (9KHz~30MHz)	±2.68dB
Radiated emissions & Radiated Power (30MHz~1GHz)	±4.98dB
Radiated emissions & Radiated Power (1GHz ~6GHz)	±4.70dB
Radiated emissions (6GHz ~18GHz)	±4.60dB
Radiated emissions (18GHz ~40GHz)	±4.12dB
Conducted emissions	±4.01dB
Occupied Channel Bandwidth	±43.58KHz
Conducted Output power	±2.06dB
Band Edge Measurements	±4.70dB
Peak to average ratio	±0.76dB

This uncertainty represents an expanded uncertainty expressed at approximately the 95% confidence level using a coverage factor of k=2.

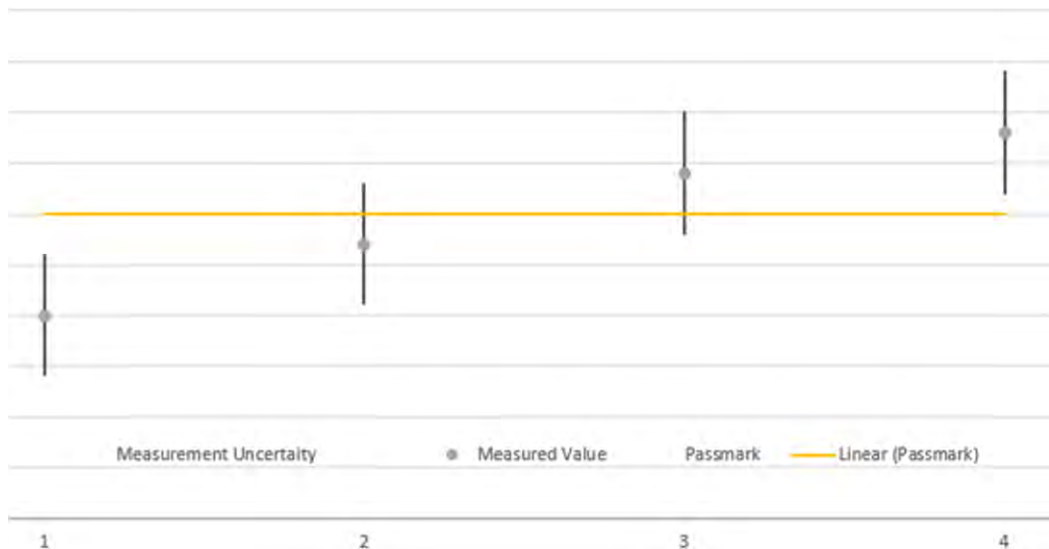

The verdicts in this test report are given according the above diagram:

Case	Measured Value	Uncertainty Range	Verdict
1	below pass mark	below pass mark	Passed
2	below pass mark	within pass mark	Passed
3	above pass mark	within pass mark	Failed
4	above pass mark	above pass mark	Failed

That means, the laboratory applies, as decision rule (see ISO/IEC 17025:2017), the so-called shared risk principle.



1.2 TEST SITE AND INSTRUMENTS

Equipment	Manufacturer	Model No.	Serial No.	Last Cal.	Next Cal.
Pre-Amplifier	R&S	SCU18F1	100815	Aug.30,22	Aug.29,24
Pre-Amplifier	R&S	SCU08F1	101028	Sep.16,22	Sep.15,24
Vector Signal Generator	R&S	SMBV100B	102176	Feb.16,22	Feb.15,24
Vector Signal Generator	R&S	SMBV100B	102176	Feb.15,24	Feb.14,26
Signal Generator	R&S	SMB100A	182185	Feb.16,22	Feb.15,24
Signal Generator	R&S	SMB100A	182185	Feb.15,24	Feb.14,26
3m Fully-anechoic Chamber	TDK	9m*6m*6m	HRSW-SZ-E MC-01Chamber	Nov.25,22	Nov.24,25
3m Semi-anechoic Chamber	TDK	9m*6m*6m	HRSW-SZ-E MC-02Chamber	Nov.25,22	Nov.24,25
EMI TEST Receiver	R&S	ESR26	101734	Feb.25,22	Feb.24,24
EMI TEST Receiver	R&S	ESR26	101734	Feb.24,24	Feb.23,26
EMI TEST Receiver	R&S	ESW44	101973	Feb.25,22	Feb.24,24
EMI TEST Receiver	R&S	ESW44	101973	Feb.24,24	Feb.23,26
Bilog Antenna	SCHWARZBECK	VULB 9163	1264	Feb.28,22	Feb.27,24
Bilog Antenna	SCHWARZBECK	VULB 9163	1264	Feb.27,24	Feb.26,26
Horn Antenna	ETS-LINDGREN	3117	227836	Aug.22,22	Aug.21,24
Horn Antenna (18GHz-40GHz)	Steatite Q-par Antennas	QMS 00880	23486	Feb.23,22	Feb.22,24
Horn Antenna (18GHz-40GHz)	Steatite Q-par Antennas	QMS 00880	23486	Feb.22,24	Feb.21,26
Horn Antenna	Steatite Q-par Antennas	QMS 00208	23485	Aug.22,22	Aug.21,24
Loop Antenna	SCHWARZ	HFH2-Z2/Z2E	100976	Feb.23,22	Feb.22,24
Loop Antenna	SCHWARZ	HFH2-Z2/Z2E	100976	Feb.22,24	Feb.21,26
WIDEBANDRADIO COMMUNICATION TESTER	R&S	CMW500	169399	Jun.27,22	Jun.26,24
Test Software	EMC32	EMC32	N/A	N/A	N/A
Test Software	ELEKTRA	ELEKTRA4.32	N/A	N/A	N/A
Open Switch and Control Unit	R&S	OSP220	101964	Oct.01,22	Sep.30,24
DC Source	HYELEC	HY3010B	551016	Aug.31,22	Aug.30,24
Hygrothermograph	DELI	20210528	SZ014	Sep.06,22	Sep.05,24
PC	LENOVO	E14	HRSW0024	N/A	N/A
TMC-AMI18843A(CABLE)	R&S	HF290-NMNM-7.00M	N/A	N/A	N/A
TMC-AMI18843A(CABLE)	R&S	HF290-NMNM-4.00M	N/A	N/A	N/A
CABLE	R&S	W13.02	N/A	Apr.28,23	Apr.27,24
CABLE	R&S	W12.14	N/A	Apr.28,23	Apr.27,24



CABLE	R&S	J12J103539-00-1	SEP-03-20-069	Apr.28,23	Apr.27,24
CABLE	R&S	J12J103539-00-1	SEP-03-20-070	Apr.28,23	Apr.27,24
Temperature Chamber	votsch	VT4002	58566078100050	May.31,22	May.30,24

- NOTE:**
1. The calibration interval of the above test instruments is 12/ 24 / 36 months and the calibrations are traceable to CEPREI/CHINA, GRGT/CHINA and NIM/CHINA.
 2. The test was performed in 3m Semi-anechoic Chamber and RF Oven Room.
 3. The horn antenna is used only for the measurement of emission frequency above 1GHz if tested.
 4. The FCC Site Registration No. is 434559; The Designation No. is CN1325.

Equipment	Manufacturer	Model No.	Serial No.	Last Cal.	Next Cal.
MXE EMI Receiver	KEYSIGHT	N9038A-544	MY54450026	Mar. 28,23	Mar. 27,24
EXA Signal Analyzer	KEYSIGHT	N9010A-544	MY54510355	May.10,23	May.09,24
Loop Antenna	Schwarzbeck	FMZB 1519B	00173	Sep.02,23	Sep.01,24
Bilog Antenna	ETS-LINDGREN	3143B	00161965	Feb. 18,23	Feb. 17,24
Bilog Antenna	ETS-LINDGREN	3143B	00161965	Feb. 17,24	Feb. 16,25
Horn Antenna	ETS-LINDGREN	3117	00168692	Feb. 18,23	Feb. 17,24
Horn Antenna	ETS-LINDGREN	3117	00168692	Feb. 17,24	Feb. 16,25
Horn Antenna (18GHz-40GHz)	N/A	QWH-SL-18-40-K-SG/QMS-00361	15433	Sep.03, 23	Sep.02, 24
Radio Communication Analyzer	ANRITSU	MT8820C	6201465426	Feb. 14,23	Feb. 13,24
Radio Communication Analyzer	ANRITSU	MT8820C	6201465426	Feb. 13,24	Feb. 12,25
Signal Pre-Amplifier	EMSI	EMC 9135	980249	May. 06,23	May. 05,24
Signal Pre-Amplifier	EMSI	EMC 012645B	980257	May.10,23	May.09,24
Signal Pre-Amplifier	EMSI	EMC 184045B	980259	Feb. 17,23	Feb.16,24
Signal Pre-Amplifier	EMSI	EMC 184045B	980259	Feb.16,24	Feb.15,25
3m Semi-anechoic Chamber	ETS-LINDGREN	9m*6m*6m	Euroshieldpn-CT0001143-1216	Nov. 14,23	Nov. 13,26
Test Software	E3	V 9.160323	N/A	N/A	N/A
Test Software	JS1120	3.1.36	N/A	N/A	N/A
10dB Attenuator	JFW/USA	50HF-010-SMA	50HF-010-SMA	May. 06,23	May. 05,24
Power Meter	Anritsu	ML2495A	1506002	Feb. 14,23	Feb. 13,24
Power Meter	Anritsu	ML2495A	1506002	Feb. 13,24	Feb. 12,25
Power Sensor	Anritsu	MA2411B	1339352	Feb. 14,23	Feb. 13,24
Power Sensor	Anritsu	MA2411B	1339352	Feb. 13,24	Feb. 12,25
Temperature Chamber	ESPEC	SH-242	93000855	May. 06,23	May. 05,24
MXG Analog Microwave Signal Generator	KEYSIGHT	N5183A	MY50143024	Feb. 14,23	Feb. 13,24
MXG Analog Microwave Signal Generator	KEYSIGHT	N5183A	MY50143024	Feb. 13,24	Feb. 12,25



**BUREAU
VERITAS**

Test Report No.: PSU-QSU2312200110RF02

Base station R&S CMW500	Rohde&Schwarz	CMW500	153085	May.10,23	May.09,24
DC Source	Kikusui/JP	PMX18-5A	N/A	Aug. 12,22	Aug. 11,23
DC Source	Kikusui/JP	PMX18-5A	N/A	Aug. 11,23	Aug. 10,24

- NOTE:**
1. The calibration interval of the above test instruments is 12/ 36 months and the calibrations are traceable to CEPREI/CHINA, GRGT/CHINA and NIM/CHINA.
 2. The test was performed in 3m Semi-anechoic Chamber and RF Oven Room.
 3. The horn antenna is used only for the measurement of emission frequency above 1GHz if tested.
 4. The FCC Site Registration No. is 525120; The Designation No. is CN1171.



2 GENERAL INFORMATION

2.1 GENERAL DESCRIPTION OF EUT

PRODUCT*	Smart Phone	
BRAND NAME*	RugGear	
MODEL NAME*	PSM03G	
MARKETING NAME*	RG880	
NOMINAL VOLTAGE*	5.0Vdc/ 9.0Vdc/ 12.0Vdc(Adapter) 3.85Vdc (Battery)	
MODULATION TYPE*	GSM/GPRS: GMSK EDGE: 8PSK CDMA2000 BC1: 1xRTT: BPSK, QPSK CDMA2000 BC1: 1xEV-DO: 8PSK WCDMA: BPSK, QPSK LTE Band 2: QPSK, 16QAM, 64QAM	
FREQUENCY RANGE	GSM/ EDGE	1850.2MHz ~ 1909.8MHz
	CDMA 2000 BC1	1851.25MHz ~ 1908.75MHz
	WCDMA	1852.4MHz ~ 1907.6MHz
	LTE Band 2 Channel Bandwidth: 1.4MHz	1850.7MHz ~ 1909.3MHz
	LTE Band 2 Channel Bandwidth: 3MHz	1851.5MHz ~ 1908.5MHz
	LTE Band 2 Channel Bandwidth: 5MHz	1852.5MHz ~ 1907.5MHz
	LTE Band 2 Channel Bandwidth: 10MHz	1855.0MHz ~ 1905.0MHz
	LTE Band 2 Channel Bandwidth: 15MHz	1857.5MHz ~ 1902.5MHz
	LTE Band 2 Channel Bandwidth: 20MHz	1860.0MHz ~ 1900.0MHz



MAX. EIRP POWER	GSM	1030.39mW
	EDGE	424.62mW
	CDMA2000 BC1 1xRTT	293.76mW
	CDMA2000 BC1 1xEV-DO	291.74mW
	WCDMA	277.33mW
	LTE Band 2 Channel Bandwidth: 1.4MHz	170.22mW
	LTE Band 2 Channel Bandwidth: 3MHz	171.4mW
	LTE Band 2 Channel Bandwidth: 5MHz	170.22mW
	LTE Band 2 Channel Bandwidth: 10MHz	170.22mW
	LTE Band 2 Channel Bandwidth: 15MHz	169.04mW
	LTE Band 2 Channel Bandwidth: 20MHz	173.38mW
EMISSION DESIGNATOR	GSM	247KGXW
	EDGE	248KG7W
	CDMA2000 BC1	1M29F9W
	WCDMA	4M19F9W
	LTE Band 2 Channel Bandwidth: 1.4MHz	QPSK: 1M09G7D
		16QAM: 1M09W7D
		64QAM: 1M09W7D
	LTE Band 2 Channel Bandwidth: 3MHz	QPSK: 2M69G7D
		16QAM: 2M69W7D
		64QAM: 2M69W7D
	LTE Band 2 Channel Bandwidth: 5MHz	QPSK: 4M48G7D
		16QAM: 4M49W7D
		64QAM: 4M49W7D
	LTE Band 2 Channel Bandwidth: 10MHz	QPSK: 8M96G7D
		16QAM: 8M94W7D
		64QAM: 8M97W7D
	LTE Band 2 Channel Bandwidth: 15MHz	QPSK: 13M4G7D
		16QAM: 13M5W7D
		64QAM: 13M4W7D
	LTE Band 2 Channel Bandwidth: 20MHz	QPSK: 17M9G7D
16QAM: 17M9W7D		



		64QAM: 17M9W7D
ANTENNA TYPE*	PIFA Antenna with -0.3dBi gain for GSM1900/ CDMA2000 BC1/WCDMA II/LTE B2	
HW VERSION*	MP619_MB_V1.02_PCB	
SW VERSION*	RG880_EEA_00.00_1_20240305	
I/O PORTS*	Refer to user's manual	
CABLE SUPPLIED*	USB cable: non-shielded cable, with w/o ferrite core, 1.0 meter	
EXTREME TEMPERATURE*	-10°C-50 °C	
EXTREME VOLTAGE*	3.6V – 4.4V	

NOTE:

- *Since the above data and/or information is provided by the client relevant results or conclusions of this report are only made for these data and/or information , Test Lab is not responsible for the authenticity, integrity and results of the data and information and/or the validity of the conclusion.
- For a more detailed features description, please refer to the manufacturer's specifications or the user's manual.
- The EUT incorporates a SISO function. Physically, the EUT provides one completed transmitter and two receivers.

MODULATION MODE	TX FUNCTION
GSM/GPRS/EDGE	1TX/2RX
CDMA 2000 BC1	1TX/2RX
WCDMA	1TX/2RX
LTE	1TX/2RX

- For the test results, the EUT had been tested with all conditions. But only the worst case was shown in test report.
- List of Accessory:**

ACCESSORIES	BRAND	MANUFACTURER	MODEL	SPECIFICATION
CPU	QUALCOMM	N/A	SM6225	N/A
eMMC 1 (=ROM 1)	SAMSUNG	N/A	KM2L9001CM-B518	N/A
eMMC 2 (=ROM 2)	Hynix	N/A	H9QT0GECN6X145R	N/A
RAM 1	N/A	N/A	N/A	N/A
RAM 2	N/A	N/A	N/A	N/A
BT/WLAN Module	N/A	N/A	N/A	N/A
NFC chipset	NXP	N/A	N/A	N/A



Battery	N/A	N/A	BL450AGP	Power Rating: 4.4V 4500mAh
Adapter	N/A	SHENZHEN MERRYKING ELECTRONICS CO.. LTD	MK-Q181US	I/P: 100-240Vac, 50/60Hz, 0.5A, O/P:5.0V 3.0A or 9.0V 2.0A or 12.0V 1.5A
USB Cable	N/A	Huizhou Huating Technology Co., Ltd	USB1.0	Signal Line,1.0meter



2.2 CONFIGURATION OF SYSTEM UNDER TEST

FOR RADIATION EMISSION TEST

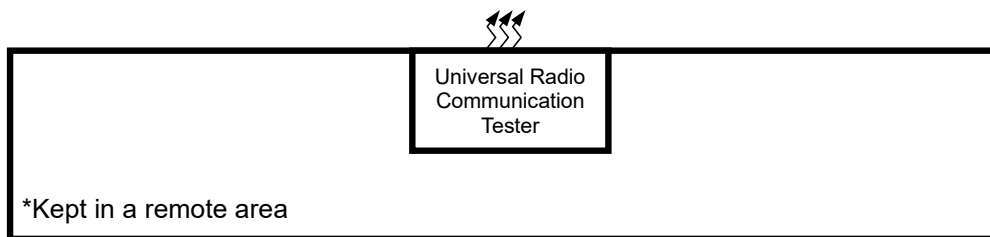
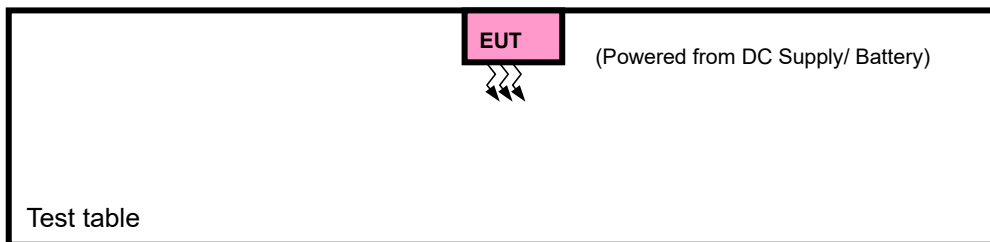
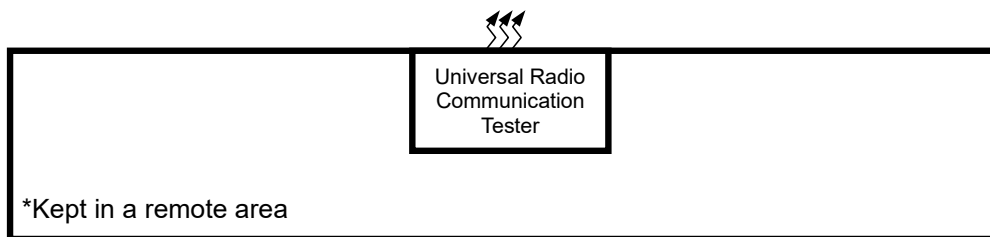
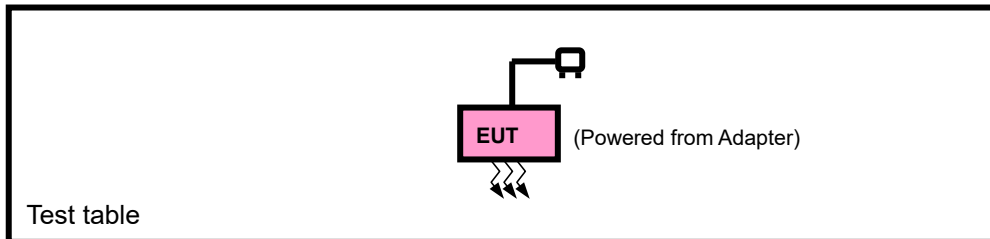



2.3 DESCRIPTION OF SUPPORT UNITS

The EUT has been tested as an independent unit together with other necessary accessories or support units. The following support units or accessories were used to form a representative test configuration during the tests.

NO.	PRODUCT	BRAND	MODEL NO.	SERIAL NO.	FCC ID
1	N/A	N/A	N/A	N/A	N/A

NO.	SIGNAL CABLE DESCRIPTION OF THE ABOVE SUPPORT UNITS
1	USB Line: Shielded, Detachable 1.0m;

2.4 TEST ITEM AND TEST CONFIGURATION

Pre-Scan has been conducted to determine the worst-case mode from all possible combinations between available modulations, data rates, XYZ axis and antenna ports. The worst case in EIRP and radiated emission was found when positioned on X-plane for GSM/EDGE/ LTE. Following channel(s) was (were) selected for the final test as listed below:

EUT CONFIGURE MODE	DESCRIPTION
A	EUT + Adapter+ USB Cable with GSM or CDMA2000 or WCDMA or LTE link
B	EUT + Battery with GSM or CDMA2000 or WCDMA or LTE link

GSM MODE

EUT CONFIGURE MODE	TEST ITEM	AVAILABLE CHANNEL	TESTED CHANNEL	MODE
A	EIRP	512 to 810	512, 661, 810	GSM,EDGE
B	FREQUENCY STABILITY	512 to 810	512, 661, 810	GSM,EDGE
A	OCCUPIED BANDWIDTH	512 to 810	512, 661, 810	GSM,EDGE
A	PEAK TO AVERAGE RATIO	512 to 810	512, 661, 810	GSM,EDGE
A	BAND EDGE	512 to 810	512, 810	GSM,EDGE
A	CONDCUDED EMISSION	512 to 810	512, 661, 810	GSM,EDGE
A	RADIATED EMISSION	512 to 810	512, 661, 810	GSM,EDGE



CDMA2000 BC1

EUT CONFIGURE MODE	TEST ITEM	AVAILABLE CHANNEL	TESTED CHANNEL	MODE
A	ERP	25 to 1175	25, 600, 1175	CDMA
B	FREQUENCY STABILITY	25 to 1175	25, 600, 1175	CDMA
A	OCCUPIED BANDWIDTH	25 to 1175	25, 600, 1175	CDMA
A	BAND EDGE	25 to 1175	25, 1175	CDMA
A	CONDCUDED EMISSION	25 to 1175	25, 600, 1175	CDMA
A	RADIATED EMISSION	25 to 1175	25, 600, 1175	CDMA
A	PEAK TO AVERAGE RATIO	25 to 1175	25, 600, 1175	CDMA

WCDMA

EUT CONFIGURE MODE	TEST ITEM	AVAILABLE CHANNEL	TESTED CHANNEL	MODE
A	EIRP	9262 to 9538	9262, 9400, 9538	WCDMA
B	FREQUENCY STABILITY	9262 to 9538	9262, 9400, 9538	WCDMA
A	OCCUPIED BANDWIDTH	9262 to 9538	9262, 9400, 9538	WCDMA
A	PEAK TO AVERAGE RATIO	9262 to 9538	9262, 9400, 9538	WCDMA
A	BAND EDGE	9262 to 9538	9262, 9538	WCDMA
A	CONDCUDED EMISSION	9262 to 9538	9262, 9400, 9538	WCDMA
A	RADIATED EMISSION	9262 to 9538	9262, 9400, 9538	WCDMA



LTE BAND 2 MODE

EUT CONFIGURE MODE	TEST ITEM	AVAILABLE CHANNEL	TESTED CHANNEL	CHANNEL BANDWIDTH	MODULATION	MODE
A	EIRP	18607 to 19193	18607, 18900, 19193	1.4MHz	QPSK,16QAM,64QAM	1 RB / 0 RB Offset
		18615 to 19185	18615, 18900, 19185	3MHz	QPSK,16QAM,64QAM	1 RB / 0 RB Offset
		18625 to 19175	18625, 18900, 19175	5MHz	QPSK,16QAM,64QAM	1 RB / 0 RB Offset
		18650 to 19150	18650, 18900, 19150	10MHz	QPSK,16QAM,64QAM	1 RB / 0 RB Offset
		18675 to 19125	18675, 18900, 19125	15MHz	QPSK,16QAM,64QAM	1 RB / 0 RB Offset
		18700 to 19100	18700, 18900, 19100	20MHz	QPSK,16QAM,64QAM	1 RB / 0 RB Offset
B	FREQUENCY STABILITY	18607 to 19193	18607, 18900, 19193	1.4MHz	QPSK,16QAM,64QAM	Full RB / 0 RB Offset
		18615 to 19185	18615, 18900, 19185	3MHz	QPSK,16QAM,64QAM	Full RB / 0 RB Offset
		18625 to 19175	18625, 18900, 19175	5MHz	QPSK,16QAM,64QAM	Full RB / 0 RB Offset
		18650 to 19150	18650, 18900, 19150	10MHz	QPSK,16QAM,64QAM	Full RB / 0 RB Offset
		18675 to 19125	18675, 18900, 19125	15MHz	QPSK,16QAM,64QAM	Full RB / 0 RB Offset
		18700 to 19100	18700, 18900, 19100	20MHz	QPSK,16QAM,64QAM	Full RB / 0 RB Offset
A	OCCUPIED BANDWIDTH	18607 to 19193	18607, 18900, 19193	1.4MHz	QPSK,16QAM,64QAM	Full RB / 0 RB Offset
		18615 to 19185	18615, 18900, 19185	3MHz	QPSK,16QAM,64QAM	Full RB / 0 RB Offset
		18625 to 19175	18625, 18900, 19175	5MHz	QPSK,16QAM,64QAM	Full RB / 0 RB Offset
		18650 to 19150	18650, 18900, 19150	10MHz	QPSK,16QAM,64QAM	Full RB / 0 RB Offset
		18675 to 19125	18675, 18900, 19125	15MHz	QPSK,16QAM,64QAM	Full RB / 0 RB Offset
		18700 to 19100	18700, 18900, 19100	20MHz	QPSK,16QAM,64QAM	Full RB / 0 RB Offset
A	PEAK TO AVERAGE RATIO	18607 to 19193	18607, 18900, 19193	1.4MHz	QPSK,16QAM,64QAM	1 RB / 0 RB Offset Full RB / 0 RB Offset
		18615 to 19185	18615, 18900, 19185	3MHz	QPSK,16QAM,64QAM	1 RB / 0 RB Offset Full RB / 0 RB Offset
		18625 to 19175	18625, 18900, 19175	5MHz	QPSK,16QAM,64QAM	1 RB / 0 RB Offset Full RB / 0 RB Offset
		18650 to 19150	18650, 18900, 19150	10MHz	QPSK,16QAM,64QAM	1 RB / 0 RB Offset Full RB / 0 RB Offset
		18675 to 19125	18675, 18900, 19125	15MHz	QPSK,16QAM,64QAM	1 RB / 0 RB Offset Full RB / 0 RB Offset
		18700 to 19100	18700, 18900, 19100	20MHz	QPSK,16QAM,64QAM	1 RB / 0 RB Offset Full RB / 0 RB Offset
A	BAND EDGE	18607 to 19193	18607	1.4MHz	QPSK,16QAM,64QAM	1 RB / 0 RB Offset Full RB / 0 RB Offset
			19193	1.4MHz	QPSK,16QAM,64QAM	1 RB / 5 RB Offset Full RB / 0 RB Offset
		18615 to 19185	18615	3MHz	QPSK,16QAM,64QAM	1 RB / 0 RB Offset Full RB / 0 RB Offset
			19185	3MHz	QPSK,16QAM,64QAM	1 RB / 14 RB Offset Full RB / 0 RB Offset
		18625 to 19175	18625	5MHz	QPSK,16QAM,64QAM	1 RB / 0 RB Offset Full RB / 0 RB Offset
			19175	5MHz	QPSK,16QAM,64QAM	1 RB / 24 RB Offset Full RB / 0 RB Offset
		18650 to 19150	18650	10MHz	QPSK,16QAM,64QAM	1 RB / 0 RB Offset



			19150	10MHz	QPSK,16QAM,64QAM	Full RB / 0 RB Offset
						1 RB / 49 RB Offset
		18675 to 19125	18675	15MHz	QPSK,16QAM,64QAM	Full RB / 0 RB Offset
						1 RB / 0 RB Offset
		18700 to 19100	19125	15MHz	QPSK,16QAM,64QAM	Full RB / 0 RB Offset
						1 RB / 74 RB Offset
			18700	20MHz	QPSK,16QAM,64QAM	Full RB / 0 RB Offset
						1 RB / 0 RB Offset
		19100	20MHz	QPSK,16QAM,64QAM	Full RB / 0 RB Offset	
					1 RB / 99 RB Offset	
A	CONDCUDED EMISSION	18607 to 19193	18607, 18900, 19193	1.4MHz	QPSK,16QAM,64QAM	1 RB / 0 RB Offset
		18615 to 19185	18615, 18900, 19185	3MHz	QPSK,16QAM,64QAM	1 RB / 0 RB Offset
		18625 to 19175	18625, 18900, 19175	5MHz	QPSK,16QAM,64QAM	1 RB / 0 RB Offset
		18650 to 19150	18650, 18900, 19150	10MHz	QPSK,16QAM,64QAM	1 RB / 0 RB Offset
		18675 to 19125	18675, 18900, 19125	15MHz	QPSK,16QAM,64QAM	1 RB / 0 RB Offset
		18700 to 19100	18700, 18900, 19100	20MHz	QPSK,16QAM,64QAM	1 RB / 0 RB Offset
A	RADIATED EMISSION	18607 to 19193	18607, 18900, 19193	1.4MHz	QPSK	1 RB / 0 RB Offset
		18615 to 19185	18900	3MHz	QPSK	1 RB / 0 RB Offset
		18625 to 19175	18900	5MHz	QPSK	1 RB / 0 RB Offset
		18650 to 19150	18900	10MHz	QPSK	1 RB / 0 RB Offset
		18675 to 19125	18900	15MHz	QPSK	1 RB / 0 RB Offset
		18700 to 19100	18900	20MHz	QPSK	1 RB / 0 RB Offset

Note: 1.This device was tested under all bandwidths, RB configurations and modulations. The worst case was found in QPSK modulation.



TEST CONDITION:

TEST ITEM	ENVIRONMENTAL CONDITIONS	INPUT POWER	TESTED BY
EIRP	23deg. C, 70%RH	DC 5.0V/ 9.0V/ 12.0V By Adapter	Hanwen Xu
FREQUENCY STABILITY	23deg. C, 70%RH	DC 3.6V/ 3.85V/ 4.4V By Battery	Hanwen Xu/ Jace Hu
OCCUPIED BANDWIDTH	23deg. C, 70%RH	DC 5.0V/ 9.0V/ 12.0V By Adapter	Hanwen Xu/ Jace Hu
BAND EDGE	23deg. C, 70%RH	DC 5.0V/ 9.0V/ 12.0V By Adapter	Hanwen Xu/ Jace Hu
CONDCUDED EMISSION	23deg. C, 70%RH	DC 5.0V/ 9.0V/ 12.0V By Adapter	Hanwen Xu/ Jace Hu
RADIATED EMISSION	23deg. C, 70%RH	DC 5.0V/ 9.0V/ 12.0V By Adapter	Hanwen Xu/ Jace Hu
PEAK TO AVERAGE RATIO	23deg. C, 70%RH	DC 5.0V/ 9.0V/ 12.0V By Adapter	Hanwen Xu/ Jace Hu

2.5 EUT OPERATING CONDITIONS

The EUT makes a call to the communication simulator. The communication simulator station system controlled a EUT to export maximum output power under transmission mode and specific channel frequency.

2.6 GENERAL DESCRIPTION OF APPLIED STANDARDS

The EUT is a RF product. According to the specifications of the manufacturer, it must comply with the requirements of the following standards:

FCC 47 CFR Part 2

FCC 47 CFR Part 24

KDB 971168 D01 Power Meas License Digital Systems v03r01

ANSI/TIA/EIA-603-D

ANSI/TIA/EIA-603-E

ANSI C63.26-2015

NOTE: All test items have been performed and recorded as per the above standards.



3 TEST TYPES AND RESULTS

3.1 OUTPUT POWER MEASUREMENT

3.1.1 LIMITS OF OUTPUT POWER MEASUREMENT

Mobile and portable stations are limited to 2 watts EIRP.

3.1.2 TEST PROCEDURES

EIRP MEASUREMENT:

Per KDB 971168 D01 Power Meas License Digital Systems v03r01 or subclause 5.2.5.5 of ANSI C63.26-2015, the relevant equation for determining the ERP or EIRP from the conducted RF output power measured using the guidance provided above is:

$$\text{ERP or EIRP} = P_{\text{Meas}} + G_{\text{T}} - L_{\text{C}}$$

Where:

ERP or EIRP = effective radiated power or equivalent isotropically radiated power, respectively

(expressed in the same units as P_{Meas} , typically dBW or dBm);

P_{Meas} = measured transmitter output power or PSD, in dBm or dBW;

G_{T} = gain of the transmitting antenna, in dBd (ERP) or dBi (EIRP);

L_{C} = signal attenuation in the connecting cable between the transmitter and antenna, in dB.

CONDUCTED POWER MEASUREMENT:

The EUT was set up for the maximum power with WCDMA link data modulation and link up with simulator. Set the EUT to transmit under low, middle and high channel and record the power level shown on simulator.



3.1.3 TEST SETUP

EIRP / ERP Measurement:

CONDUCTED POWER MEASUREMENT:

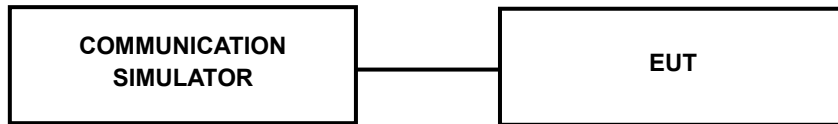

3.1.4 TEST RESULTS

CONDUCTED OUTPUT POWER (dBm) :

Band	GSM1900		
Channel	512	661	810
Frequency(MHz)	1850.2	1880	1909.8
GSM	30.02	30.26	30.43
GPRS 1Tx Slot	30.03	30.21	30.39
GPRS 2Tx Slot	29.05	29.26	29.45
GPRS 3Tx Slot	27.62	27.84	28.04
GPRS 4Tx Slot	25.84	25.98	26.04
EDGE 1Tx Slot	26.16	26.42	26.58
EDGE 2Tx Slot	25.58	25.73	25.87
EDGE 3Tx Slot	23.54	23.58	23.76
EDGE 4Tx Slot	21.62	21.69	21.83

Band	CDMA2000 BC1		
Channel	25	600	1175
Frequency(MHz)	1851.25	1880	1908.75
RC1 SO55	24.73	24.68	24.79
RC3 SO55	24.86	24.98	24.83
RC3 SO32 (F+SCH)	24.92	24.88	24.85
RC3 SO32 (+SCH)	24.95	24.96	24.95
RTAP 153.6Kbps	24.93	24.92	24.90
RETAP 4096Bits	24.90	24.95	24.88



Band	WCDMA II		
	9262	9400	9538
TX Channel	9262	9400	9538
Rx Channel	9662	9800	9938
Frequency(MHz)	1852.4	1880	1907.6
RMC 12.2K	24.52	24.69	24.73
HSDPA Subtest-1	23.71	23.89	23.88
HSDPA Subtest-2	23.65	23.83	23.91
HSDPA Subtest-3	23.17	23.39	23.45
HSDPA Subtest-4	23.13	23.33	23.32
DC-HSDPA Subtest-1	23.63	23.83	23.78
DC-HSDPA Subtest-2	23.65	23.72	23.83
DC-HSDPA Subtest-3	23.24	23.22	23.40
DC-HSDPA Subtest-4	23.17	23.25	23.34
HSUPA Subtest-1	23.69	23.86	23.94
HSUPA Subtest-2	22.68	22.88	22.94
HSUPA Subtest-3	23.19	23.23	23.31
HSUPA Subtest-4	22.64	22.79	22.88
HSUPA Subtest-5	23.67	23.82	23.87



LTE BAND 2

Band/BW	Modulation	RB Size	RB Offset	Low CH 18607	Mid CH 18900	High CH 19193
				Frequency 1850.7 MHz	Frequency 1880 MHz	Frequency 1909.3 MHz
2/ 1.4	QPSK	1	0	22.23	22.43	22.58
		1	2	22.36	22.48	22.61
		1	5	21.98	22.12	22.10
		3	0	22.29	22.48	22.54
		3	1	22.25	22.57	22.51
		3	3	22.17	22.41	22.34
		6	0	21.36	21.65	21.57
	16QAM	1	0	21.55	21.70	21.75
		1	2	21.65	21.77	21.81
		1	5	21.17	21.37	21.43
		3	0	21.22	21.50	21.49
		3	1	21.40	21.56	21.56
		3	3	21.13	21.22	21.32
		6	0	20.43	20.57	20.67
	64QAM	1	0	20.44	20.71	20.75
		1	2	20.64	20.60	20.73
		1	5	20.04	20.17	20.28
		3	0	20.16	20.47	20.43
		3	1	20.29	20.60	20.57
		3	3	20.12	20.28	20.43
		6	0	19.36	19.53	19.63



Band/BW	Modulation	RB Size	RB Offset	Low CH 18615	Mid CH 18900	High CH 19185
				Frequency 1851.5 MHz	Frequency 1880 MHz	Frequency 1908.5 MHz
2 / 3	QPSK	1	0	22.22	22.38	22.48
		1	7	22.29	22.54	22.64
		1	14	21.91	22.08	22.13
		8	0	21.42	21.60	21.72
		8	3	21.47	21.74	21.71
		8	7	21.22	21.54	21.54
		15	0	21.38	21.55	21.67
	16QAM	1	0	21.45	21.64	21.76
		1	7	21.67	21.81	21.89
		1	14	21.26	21.36	21.32
		8	0	20.49	20.63	20.70
		8	3	20.51	20.69	20.70
		8	7	20.33	20.40	20.55
		15	0	20.35	20.60	20.61
	64QAM	1	0	20.37	20.71	20.74
		1	7	20.51	20.60	20.69
		1	14	20.02	20.16	20.29
		8	0	19.45	19.67	19.63
		8	3	19.45	19.65	19.66
		8	7	19.36	19.48	19.49
		15	0	19.39	19.64	19.58



Band/BW	Modulation	RB Size	RB Offset	Low CH 18625	Mid CH 18900	High CH 19175
				Frequency 1852.5 MHz	Frequency 1880 MHz	Frequency 1907.5 MHz
2/5	QPSK	1	0	22.17	22.36	22.50
		1	12	22.35	22.61	22.58
		1	24	21.89	22.10	22.12
		12	0	21.39	21.70	21.64
		12	6	21.43	21.66	21.78
		12	13	21.34	21.52	21.64
		25	0	21.34	21.67	21.65
	16QAM	1	0	21.50	21.65	21.70
		1	12	21.71	21.82	21.90
		1	24	21.28	21.35	21.45
		12	0	20.41	20.67	20.70
		12	6	20.48	20.69	20.81
		12	13	20.27	20.42	20.49
		25	0	20.47	20.51	20.63
	64QAM	1	0	20.38	20.68	20.70
		1	12	20.58	20.55	20.65
		1	24	20.01	20.16	20.22
		12	0	19.37	19.63	19.64
		12	6	19.44	19.76	19.72
		12	13	19.27	19.54	19.61
		25	0	19.37	19.60	19.65



Band/BW	Modulation	RB Size	RB Offset	Low CH 18650	Mid CH 18900	High CH 19150
				Frequency 1855 MHz	Frequency 1880 MHz	Frequency 1905 MHz
2 / 10	QPSK	1	0	22.20	22.37	22.55
		1	24	22.29	22.55	22.61
		1	49	21.91	22.07	22.11
		25	0	21.39	21.73	21.65
		25	12	21.51	21.64	21.68
		25	25	21.21	21.56	21.65
		50	0	21.32	21.65	21.64
	16QAM	1	0	21.45	21.77	21.74
		1	24	21.72	21.82	21.91
		1	49	21.28	21.38	21.45
		25	0	20.47	20.68	20.66
		25	12	20.49	20.67	20.69
		25	25	20.27	20.47	20.48
		50	0	20.37	20.62	20.63
	64QAM	1	0	20.37	20.63	20.68
		1	24	20.56	20.54	20.65
		1	49	20.12	20.15	20.25
		25	0	19.39	19.63	19.70
		25	12	19.46	19.77	19.68
		25	25	19.26	19.55	19.61
		50	0	19.33	19.62	19.66



Band/BW	Modulation	RB Size	RB Offset	Low CH 18675	Mid CH 18900	High CH 19125
				Frequency 1857.5 MHz	Frequency 1880 MHz	Frequency 1902.5 MHz
2/ 15	QPSK	1	0	22.30	22.43	22.58
		1	37	22.28	22.58	22.57
		1	74	21.90	22.13	22.10
		36	0	21.40	21.60	21.71
		36	19	21.41	21.63	21.64
		36	39	21.30	21.50	21.57
		75	0	21.34	21.61	21.60
	16QAM	1	0	21.43	21.64	21.69
		1	37	21.62	21.76	21.84
		1	74	21.20	21.37	21.41
		36	0	20.39	20.59	20.62
		36	19	20.46	20.62	20.80
		36	39	20.39	20.41	20.59
		75	0	20.36	20.53	20.64
	64QAM	1	0	20.45	20.63	20.73
		1	37	20.61	20.60	20.73
		1	74	20.12	20.16	20.25
		36	0	19.33	19.67	19.61
		36	19	19.54	19.67	19.74
		36	39	19.30	19.46	19.59
		75	0	19.32	19.52	19.62



Band/BW	Modulation	RB Size	RB Offset	Low CH 18700	Mid CH 18900	High CH 19100
				Frequency 1860 MHz	Frequency 1880 MHz	Frequency 1900 MHz
2/ 20	QPSK	1	0	22.32	22.45	22.62
		1	50	22.42	22.62	22.69
		1	99	22.02	22.17	22.22
		50	0	21.51	21.72	21.79
		50	25	21.56	21.76	21.81
		50	50	21.36	21.62	21.66
		100	0	21.46	21.68	21.69
	16QAM	1	0	21.58	21.78	21.82
		1	50	21.74	21.86	21.93
		1	99	21.31	21.42	21.47
		50	0	20.50	20.73	20.77
		50	25	20.60	20.77	20.82
		50	50	20.41	20.55	20.63
		100	0	20.49	20.63	20.70
	64QAM	1	0	20.48	20.73	20.76
		1	50	20.65	20.62	20.79
		1	99	20.15	20.29	20.31
		50	0	19.48	19.68	19.75
		50	25	19.56	19.79	19.80
		50	50	19.38	19.56	19.63
		100	0	19.41	19.65	19.70



EIRP POWER (dBm)

GSM 1900

Channel	Frequency (MHz)	Conducted Power (dBm)	G _T -L _C (dB)	EIRP (dBm)	EIRP (mW)	Limit (W)
512	1850.2	30.03	-0.3	29.73	939.72	2
661	1880	30.26	-0.3	29.96	990.83	2
810	1909.8	30.43	-0.3	30.13	1030.39	2

EDGE 1900

Channel	Frequency (MHz)	Conducted Power (dBm)	G _T -L _C (dB)	EIRP (dBm)	EIRP (mW)	Limit (W)
512	1850.2	26.16	-0.3	25.86	385.48	2
661	1880	26.42	-0.3	26.12	409.26	2
810	1909.8	26.58	-0.3	26.28	424.62	2

CDMA2000 BC1 1xRTT

Channel	Frequency (MHz)	Conducted Power (dBm)	G _T -L _C (dB)	EIRP (dBm)	EIRP (mW)	Limit (W)
25	1851.25	24.95	-0.3	24.65	291.74	2
600	1880	24.98	-0.3	24.68	293.76	2
1175	1908.75	24.95	-0.3	24.65	291.74	2

CDMA2000 BC1 1xEV-DO

Channel	Frequency (MHz)	Conducted Power (dBm)	G _T -L _C (dB)	EIRP (dBm)	EIRP (mW)	Limit (W)
25	1851.25	24.93	-0.3	24.63	290.4	2
600	1880	24.95	-0.3	24.65	291.74	2
1175	1908.75	24.9	-0.3	24.6	288.4	2

WCDMA

Channel	Frequency (MHz)	Conducted Power (dBm)	G _T -L _C (dB)	EIRP (dBm)	EIRP (mW)	Limit (W)
9262	1852.4	24.52	-0.3	24.22	264.24	2
9400	1880	24.69	-0.3	24.39	274.79	2
9538	1907.6	24.73	-0.3	24.43	277.33	2



LTE BAND 2

CHANNEL BANDWIDTH: 1.4MHz QPSK

Channel	Frequency (MHz)	Conducted Power (dBm)	G _{T-Lc} (dB)	EIRP (dBm)	EIRP (mW)	Limit (W)
18607	1850.7	22.36	-0.3	22.06	160.69	2
18900	1880.0	22.57	-0.3	22.27	168.66	2
19193	1909.3	22.61	-0.3	22.31	170.22	2

CHANNEL BANDWIDTH: 1.4MHz 16QAM

Channel	Frequency (MHz)	Conducted Power (dBm)	G _{T-Lc} (dB)	EIRP (dBm)	EIRP (mW)	Limit (W)
18607	1850.7	21.65	-0.3	21.35	136.46	2
18900	1880.0	21.77	-0.3	21.47	140.28	2
19193	1909.3	21.81	-0.3	21.51	141.58	2

CHANNEL BANDWIDTH: 1.4MHz 64QAM

Channel	Frequency (MHz)	Conducted Power (dBm)	G _{T-Lc} (dB)	EIRP (dBm)	EIRP (mW)	Limit (W)
18607	1850.7	20.64	-0.3	20.34	108.14	2
18900	1880	20.71	-0.3	20.41	109.9	2
19193	1909.3	20.75	-0.3	20.45	110.92	2



CHANNEL BANDWIDTH: 3MHz QPSK

Channel	Frequency (MHz)	Conducted Power (dBm)	G _{T-Lc} (dB)	EIRP (dBm)	EIRP (mW)	Limit (W)
18615	1851.5	22.29	-0.3	21.99	158.12	2
18900	1880	22.54	-0.3	22.24	167.49	2
19185	1908.5	22.64	-0.3	22.34	171.4	2

CHANNEL BANDWIDTH: 3MHz 16QAM

Channel	Frequency (MHz)	Conducted Power (dBm)	G _{T-Lc} (dB)	EIRP (dBm)	EIRP (mW)	Limit (W)
18615	1851.5	21.67	-0.3	21.37	137.09	2
18900	1880	21.81	-0.3	21.51	141.58	2
19185	1908.5	21.89	-0.3	21.59	144.21	2

CHANNEL BANDWIDTH: 3MHz 64QAM

Channel	Frequency (MHz)	Conducted Power (dBm)	G _{T-Lc} (dB)	EIRP (dBm)	EIRP (mW)	Limit (W)
18615	1851.5	20.51	-0.3	20.21	104.95	2
18900	1880	20.71	-0.3	20.41	109.9	2
19185	1908.5	20.74	-0.3	20.44	110.66	2



CHANNEL BANDWIDTH: 5MHz QPSK

Channel	Frequency (MHz)	Conducted Power (dBm)	G _T -L _C (dB)	EIRP (dBm)	EIRP (mW)	Limit (W)
18625	1852.5	22.35	-0.3	22.05	160.32	2
18900	1880	22.61	-0.3	22.31	170.22	2
19175	1907.5	22.58	-0.3	22.28	169.04	2

CHANNEL BANDWIDTH: 5MHz 16QAM

Channel	Frequency (MHz)	Conducted Power (dBm)	G _T -L _C (dB)	EIRP (dBm)	EIRP (mW)	Limit (W)
18625	1852.5	21.71	-0.3	21.41	138.36	2
18900	1880	21.82	-0.3	21.52	141.91	2
19175	1907.5	21.9	-0.3	21.6	144.54	2

CHANNEL BANDWIDTH: 5MHz 64QAM

Channel	Frequency (MHz)	Conducted Power (dBm)	G _T -L _C (dB)	EIRP (dBm)	EIRP (mW)	Limit (W)
18625	1852.5	20.58	-0.3	20.28	106.66	2
18900	1880	20.68	-0.3	20.38	109.14	2
19175	1907.5	20.7	-0.3	20.4	109.65	2



CHANNEL BANDWIDTH: 10MHz QPSK

Channel	Frequency (MHz)	Conducted Power (dBm)	G _{T-Lc} (dB)	EIRP (dBm)	EIRP (mW)	Limit (W)
18650	1855	22.29	-0.3	21.99	158.12	2
18900	1880	22.55	-0.3	22.25	167.88	2
19150	1905	22.61	-0.3	22.31	170.22	2

CHANNEL BANDWIDTH: 10MHz 16QAM

Channel	Frequency (MHz)	Conducted Power (dBm)	G _{T-Lc} (dB)	EIRP (dBm)	EIRP (mW)	Limit (W)
18650	1855	21.72	-0.3	21.42	138.68	2
18900	1880	21.82	-0.3	21.52	141.91	2
19150	1905	21.91	-0.3	21.61	144.88	2

CHANNEL BANDWIDTH: 10MHz 64QAM

Channel	Frequency (MHz)	Conducted Power (dBm)	G _{T-Lc} (dB)	EIRP (dBm)	EIRP (mW)	Limit (W)
18650	1855	20.56	-0.3	20.26	106.17	2
18900	1880	20.63	-0.3	20.33	107.89	2
19150	1905	20.68	-0.3	20.38	109.14	2



CHANNEL BANDWIDTH: 15MHz QPSK

Channel	Frequency (MHz)	Conducted Power (dBm)	G _{T-Lc} (dB)	EIRP (dBm)	EIRP (mW)	Limit (W)
18675	1857.5	22.3	-0.3	22	158.49	2
18900	1880	22.58	-0.3	22.28	169.04	2
19125	1902.5	22.58	-0.3	22.28	169.04	2

CHANNEL BANDWIDTH: 15MHz 16QAM

Channel	Frequency (MHz)	Conducted Power (dBm)	G _{T-Lc} (dB)	EIRP (dBm)	EIRP (mW)	Limit (W)
18675	1857.5	21.62	-0.3	21.32	135.52	2
18900	1880	21.76	-0.3	21.46	139.96	2
19125	1902.5	21.84	-0.3	21.54	142.56	2

CHANNEL BANDWIDTH: 15MHz 64QAM

Channel	Frequency (MHz)	Conducted Power (dBm)	G _{T-Lc} (dB)	EIRP (dBm)	EIRP (mW)	Limit (W)
18675	1857.5	20.61	-0.3	20.31	107.4	2
18900	1880	20.63	-0.3	20.33	107.89	2
19125	1902.5	20.73	-0.3	20.43	110.41	2



CHANNEL BANDWIDTH: 20MHz QPSK

Channel	Frequency (MHz)	Conducted Power (dBm)	G _{T-Lc} (dB)	EIRP (dBm)	EIRP (mW)	Limit (W)
18700	1860	22.42	-0.3	22.12	162.93	2
18900	1880	22.62	-0.3	22.32	170.61	2
19100	1900	22.69	-0.3	22.39	173.38	2

CHANNEL BANDWIDTH: 20MHz 16QAM

Channel	Frequency (MHz)	Conducted Power (dBm)	G _{T-Lc} (dB)	EIRP (dBm)	EIRP (mW)	Limit (W)
18700	1860	21.74	-0.3	21.44	139.32	2
18900	1880	21.86	-0.3	21.56	143.22	2
19100	1900	21.93	-0.3	21.63	145.55	2

CHANNEL BANDWIDTH: 20MHz 64QAM

Channel	Frequency (MHz)	Conducted Power (dBm)	G _{T-Lc} (dB)	EIRP (dBm)	EIRP (mW)	Limit (W)
18700	1860	20.65	-0.3	20.35	108.39	2
18900	1880	20.73	-0.3	20.43	110.41	2
19100	1900	20.79	-0.3	20.49	111.94	2

REMARKS: ERP Output Power (dBm) = EIRP (dBm) -2.15(dB).



3.2 FREQUENCY STABILITY MEASUREMENT

3.2.1 LIMITS OF FREQUENCY STABILITY MEASUREMENT

The frequency stability shall be sufficient to ensure that the fundamental emission stays within the authorized frequency block.

3.2.2 TEST PROCEDURE

- Device is placed at the oven room. The oven room could control the temperatures and humidity. Power warm up is at least 15 min and power applied should perform before recording frequency error.
- EUT is connected the external power supply to control the DC input power. The test voltage range is from minimum to maximum working voltage. Each step shall be record the frequency error rate.
- The temperature range step is 10 degrees in this test items. All temperature levels shall be hold the $\pm 0.5^{\circ}\text{C}$ during the measurement testing. The each temperature step shall be at least 0.5 hours, consider the EUT could be test under the stability condition.

NOTE: The frequency error was recorded frequency error from the communication simulator.

3.2.3 TEST SETUP

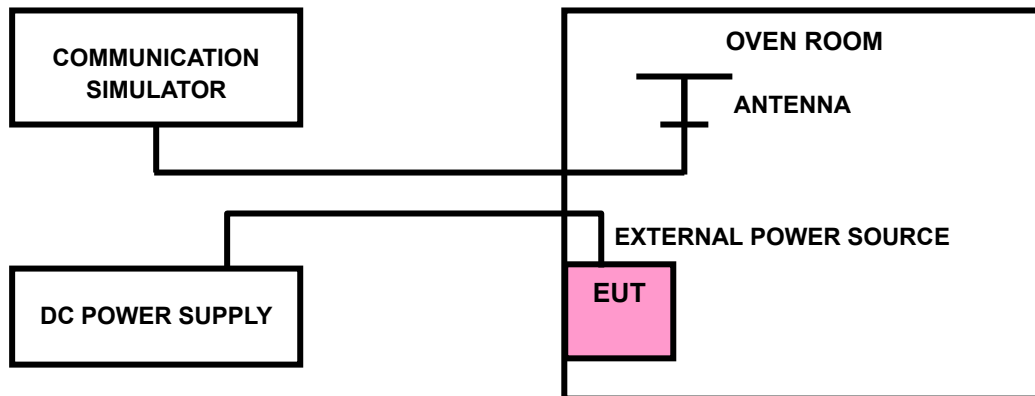



**BUREAU
VERITAS**

Test Report No.: PSU-QSU2312200110RF02

3.2.4 TEST RESULTS

Please Refer to Appendix Of this test report.

Note: VL = Low voltage(3.6V); VN/NV = Normal voltage(3.85V); VH = High voltage(4.4V);
NT = Normal temperature (25°C)



3.3 OCCUPIED BANDWIDTH MEASUREMENT

3.3.1 LIMITS OF OCCUPIED BANDWIDTH MEASUREMENT

The width of a frequency band such that, below the lower and above the upper frequency limits, the mean powers emitted are each equal to a specified percentage 0.5 % of the total mean power of a given emission.

3.3.2 TEST SETUP

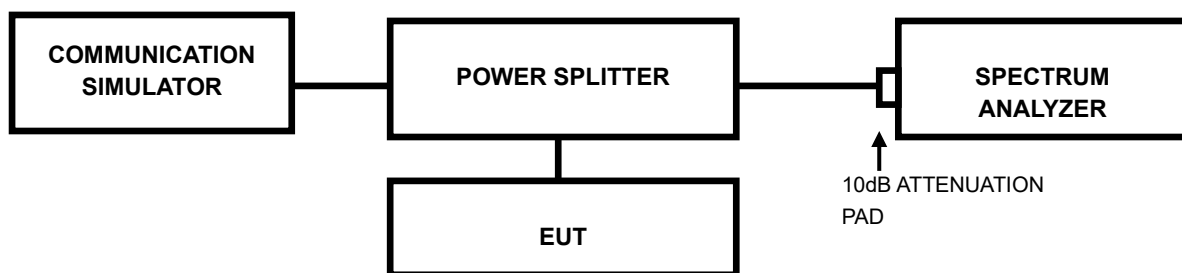

3.3.3 TEST PROCEDURES

- The conducted occupied bandwidth used the power splitter via EUT RF power connector between simulation base station and spectrum analyzer.
- Use OBW measurement function of Spectrum analyzer to measure 99 % occupied bandwidth.



Test Report No.: PSU-QSU2312200110RF02

3.3.4 TEST RESULTS

Please Refer to Appendix Of this test report.



3.4 BAND EDGE MEASUREMENTC

3.4.1 LIMITS OF BAND EDGE MEASUREMENT

Power of any emission outside of the authorized operating frequency ranges must be attenuated below the transmitting power (P) by a factor of at least $43 + 10 \log(P)$ dB. In the 1 MHz bands immediately outside and adjacent to the frequency block a resolution bandwidth of at least one percent of the emission bandwidth of the fundamental emission of the transmitter may be employed.

3.4.2 TEST SETUP

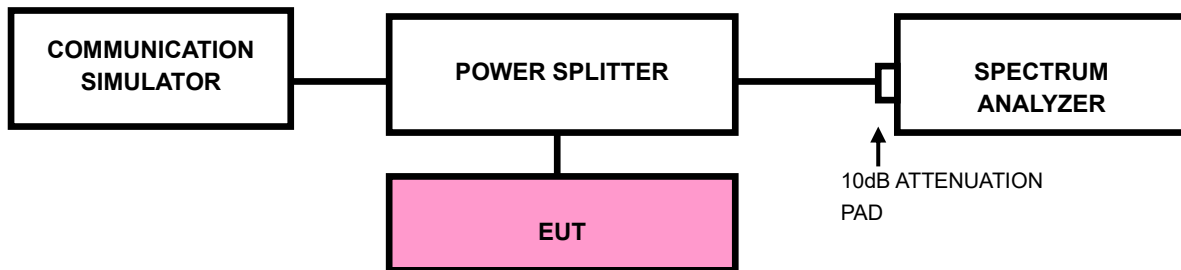



3.4.3 TEST PROCEDURES

- a) All measurements were done at low and high operational frequency range
- b) Connect the transmitter to the spectrum analyzer via coaxial cable while ensuring proper impedance matching.
- c) Tune the analyzer to the nominal center frequency of the emission bandwidth (EBW)
- d) .Set the resolution bandwidth (RBW) $\geq 1\%$ EBW in the 1MHz band immediately outside and adjacent to the band edge.
- e) Beyond the 1MHz band from the band edge, RBW=1MHz was used.
- f) Set the video bandwidth (VBW) to $\geq 3 \times$ RBW.
- g) Select the average power (RMS) display detector.
- h) Set the number of measurement points to ≥ 1001 .
- i) Use auto-coupled sweep time.
- j) Perform the measurement over an interval of time when the transmission is continuous and at its maximum power level.
- k) The RF fundamental frequency should be excluded against the limit line in the operating frequency band and use RBW is 10KHz or 100KHz.
- l) Record the max trace plot into the test report.



Test Report No.: PSU-QSU2312200110RF02

3.4.4. TEST RESULTS

Please Refer to Appendix Of this test report.



3.5 CONDUCTED SPURIOUS EMISSIONS

3.5.1 LIMITS OF CONDUCTED SPURIOUS EMISSIONS MEASUREMENT

The power of any emission outside of the authorized operating frequency ranges must be attenuated below the transmitting power (P) by a factor of at least $43 + 10 \log(P)$ dB. The emission limit equal to -13dBm .

3.5.2 TEST PROCEDURE

- The EUT makes a phone call to the communication simulator. All measurements were done at low, middle and high operational frequency range.
- Measuring frequency range is from 30MHz up to a frequency including its 10th harmonic. 10dB attenuation pad is connected with spectrum. RBW=1MHz and VBW=3MHz is used for conducted emission measurement.

3.5.3 TEST SETUP

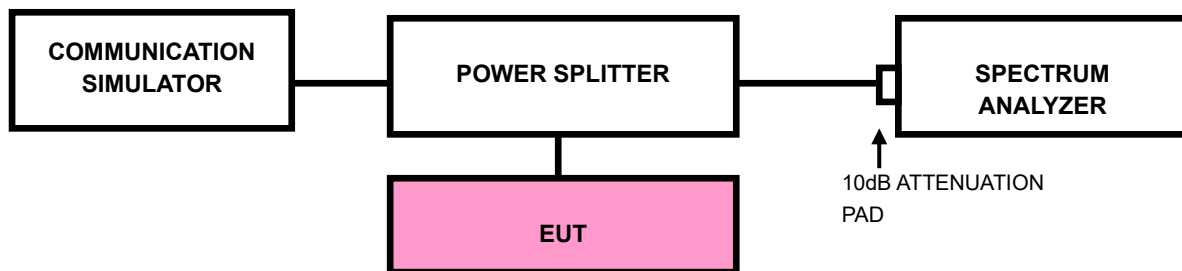



**BUREAU
VERITAS**

Test Report No.: PSU-QSU2312200110RF02

3.5.4 TEST RESULTS

NOTE : The 9K~30MHz amplitude of spurious emissions attenuated more than 20 dB below the permissible value is not required in the report.

Please Refer to Appendix Of this test report.



3.6 RADIATED EMISSION MEASUREMENT

3.6.1 LIMITS OF RADIATED EMISSION MEASUREMENT

The power of any emission outside of the authorized operating frequency ranges must be attenuated below the transmitting power (P) by a factor of at least $43 + 10 \log(P)$ dB. The emission limit equal to -13dBm .

3.6.2 TEST PROCEDURES

- a. Substitution method is used for E.I.R.P measurement. In the semi-anechoic chamber, EUT placed on the 0.8m height of Turn Table, rotated the table around 360 degrees to search the maximum radiation power and receiver antenna shall be rotated vertical and horizontal polarization and moved height from 1m to 4m to find the maximum polar radiated power. The “Read Value” is the spectrum reading the maximum power value.
- b. The substitution horn antenna is substituted for EUT at the same position and signals generator export the CW signal to the substitution antenna via a TX cable. Rotated the Turn Table and moved receiving antenna to find the maximum radiation power. Adjust output power level of S.G to get a Value of spectrum reading equal to “Read Value” of step a. Record the power level of S.G
- c. $\text{EIRP} = \text{Output power level of S.G} - \text{TX cable loss} + \text{Antenna gain of substitution horn}$.

NOTE: The resolution bandwidth and video bandwidth of test receiver/spectrum analyzer is 1MHz/3MHz.

3.6.3 DEVIATION FROM TEST STANDARD

No deviation



3.6.4 TEST SETUP

< Frequency Range below 30MHz >

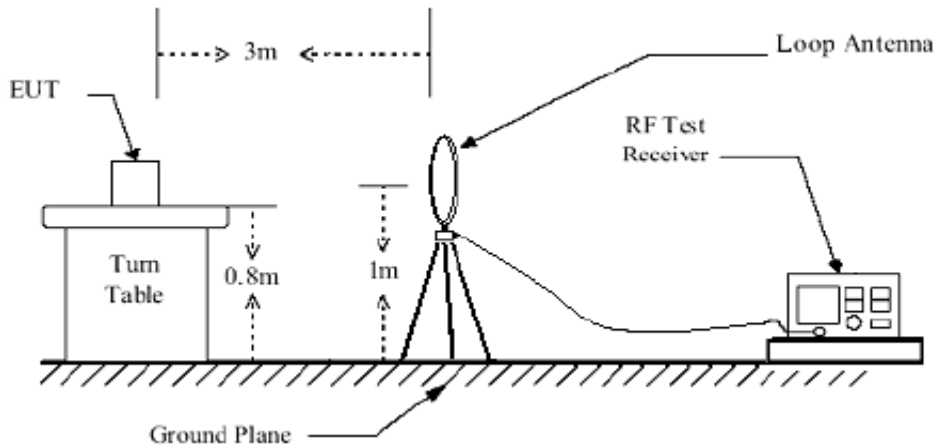

< Frequency Range 30MHz~1GHz >

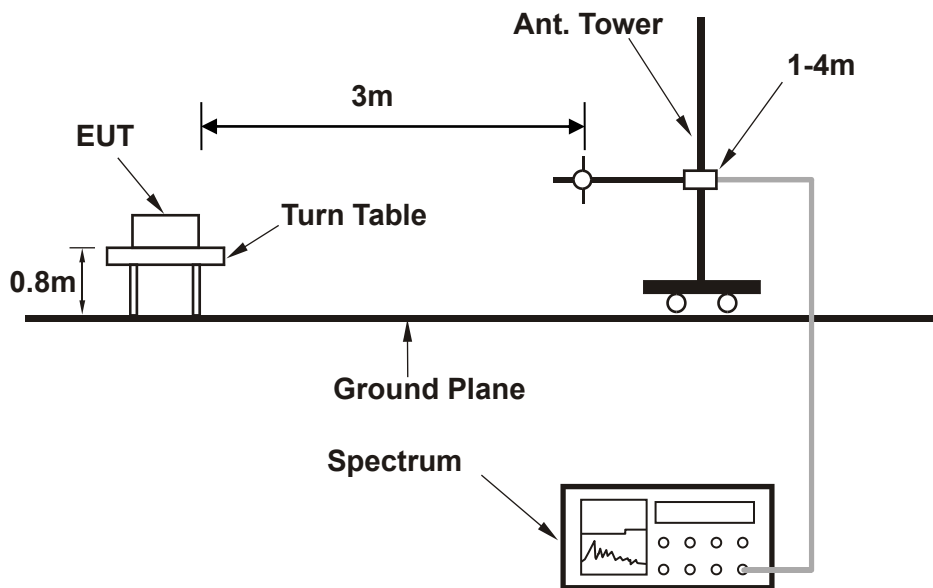



<Frequency Range above 1GHz>

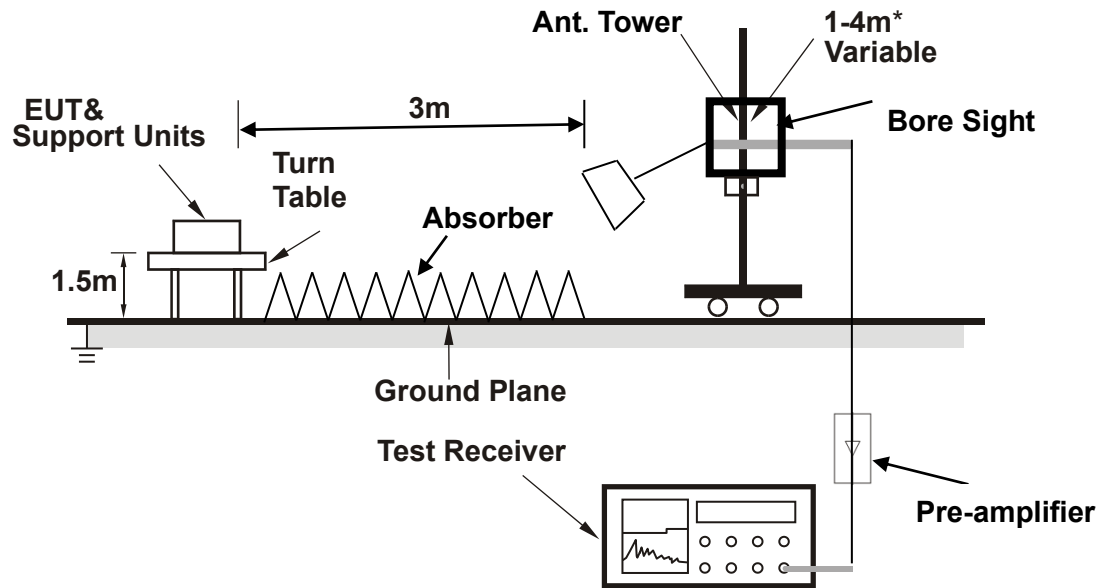

Note: Above 1G is a directional antenna

Depends on the EUT height and the antenna 3dB beamwidth both, refer to section 7.3 of CISPR 16-2-3.

For the actual test configuration, please refer to the attached file (Test Setup Photo).



**BUREAU
VERITAS**

Test Report No.: PSU-QSU2312200110RF02

3.6.5 TEST RESULTS

NOTE : The 9K~30MHz amplitude of spurious emissions attenuated more than 20 dB below the permissible value is not required in the report.

BELOW 1GHz WORST-CASE DATA

30 MHz – 1GHz data:

GSM 1900:

CHANNEL BANDWIDTH: 512~810

MODE	TX channel 512	FREQUENCY RANGE	Below 1000MHz
ENVIRONMENTAL CONDITIONS	23deg. C, 70%RH	INPUT POWER	120Vac 60HZ
TESTED BY	Hanwen Xu		
ANTENNA POLARITY & TEST DISTANCE: HORIZONTAL AT 3 M			

Rg	Frequency [MHz]	PK+ Level [dBm]	PK+ Limit [dBm]	PK+ Margin [dB]	Correction [dB]	Polarization	Azimuth [deg]	Antenna Height [m]
1	44.550	-52.37	-13.00	39.37	5.72	H	51.9	1.00
1	77.045	-55.22	-13.00	42.22	-5.90	H	355.1	2.00
1	112.450	-66.03	-13.00	53.03	-4.06	H	306.9	2.00
1	193.445	-50.42	-13.00	37.42	2.27	H	109.3	1.00
1	231.760	-52.01	-13.00	39.01	8.72	H	51.9	1.00
1	349.615	-49.08	-13.00	36.08	4.68	H	338.5	1.00

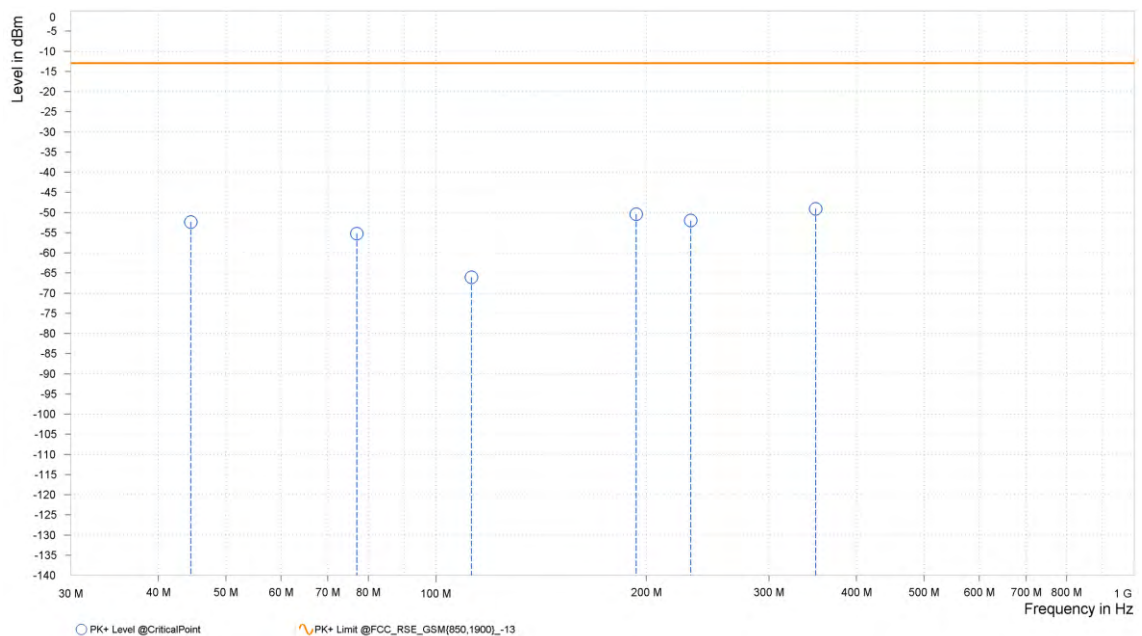



**BUREAU
VERITAS**

Test Report No.: PSU-QSU2312200110RF02

MODE	TX channel 512	FREQUENCY RANGE	Below 1000MHz
ENVIRONMENTAL CONDITIONS	23deg. C, 70%RH	INPUT POWER	120Vac 60HZ
TESTED BY	Hanwen Xu		
ANTENNA POLARITY & TEST DISTANCE: VERTICAL AT 3 M			

Rg	Frequency [MHz]	PK+ Level [dBm]	PK+ Limit [dBm]	PK+ Margin [dB]	Correction [dB]	Polarization	Azimuth [deg]	Antenna Height [m]
1	44.550	-58.35	-13.00	45.35	0.21	V	359.1	1.00
1	70.255	-61.87	-13.00	48.87	-2.36	V	193.4	2.00
1	99.355	-48.61	-13.00	35.61	12.14	V	359.1	1.00
1	195.870	-57.40	-13.00	44.40	0.74	V	193.4	2.00
1	253.100	-45.77	-13.00	32.77	1.66	V	355.7	2.00
1	396.660	-50.06	-13.00	37.06	6.13	V	339.4	1.00

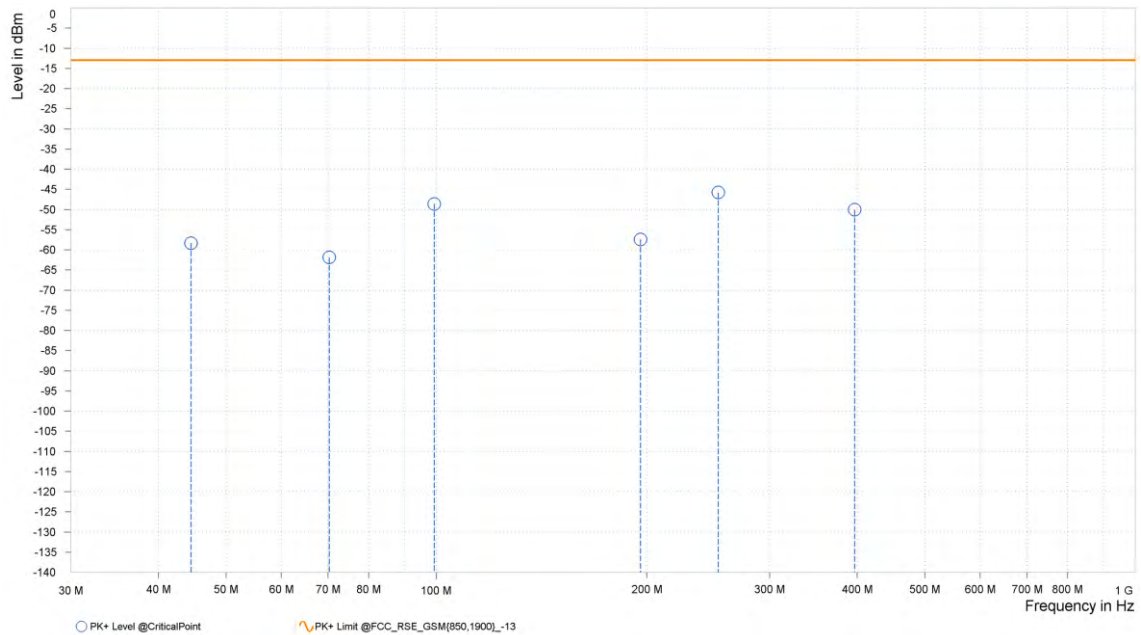



**BUREAU
VERITAS**

Test Report No.: PSU-QSU2312200110RF02

ABOVE 1GHz DATA

Note: For higher frequency, the emission is too low to be detected.

WORST-CASE DATA

GSM 1900:

CH 512

MODE	TX channel 512	FREQUENCY RANGE	Above 1000MHz
ENVIRONMENTAL CONDITIONS	23deg. C, 70%RH	INPUT POWER	120Vac 60HZ
TESTED BY	Hanwen Xu		
ANTENNA POLARITY & TEST DISTANCE: HORIZONTAL AT 3 M			

Rg	Frequency [MHz]	PK+ Level [dBm]	PK+ Limit [dBm]	PK+ Margin [dB]	Correction [dB]	Polarization	Azimuth [deg]	Antenna Height [m]
4	3,700.000	-41.66	-13.00	28.66	22.48	H	122.8	2.00
4	5,550.500	-47.76	-13.00	34.76	25.81	H	359.1	1.00

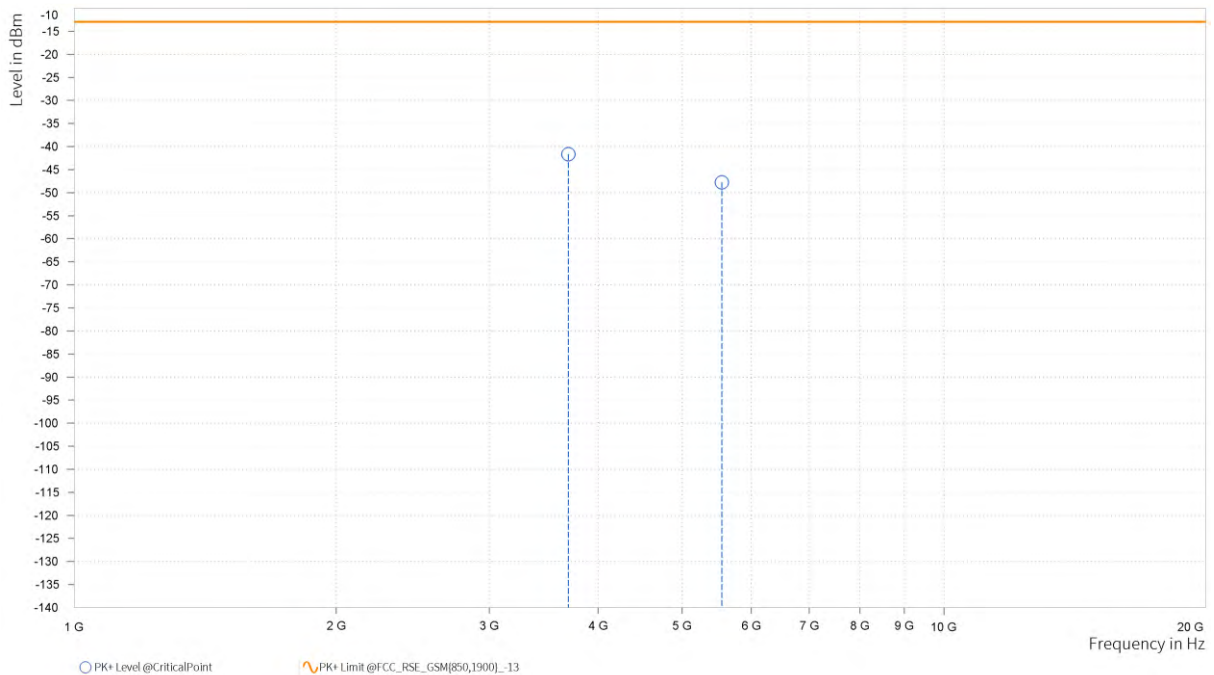



**BUREAU
VERITAS**

Test Report No.: PSU-QSU2312200110RF02

MODE	TX channel 512	FREQUENCY RANGE	Above 1000MHz
ENVIRONMENTAL CONDITIONS	23deg. C, 70%RH	INPUT POWER	120Vac 60HZ
TESTED BY	Hanwen Xu		
ANTENNA POLARITY & TEST DISTANCE: VERTICAL AT 3 M			

Rg	Frequency [MHz]	PK+ Level [dBm]	PK+ Limit [dBm]	PK+ Margin [dB]	Correction [dB]	Polarization	Azimuth [deg]	Antenna Height [m]
4	3,700.400	-44.40	-13.00	31.40	23.07	V	359.1	1.00
4	5,550.600	-47.10	-13.00	34.10	26.51	V	359	2.00

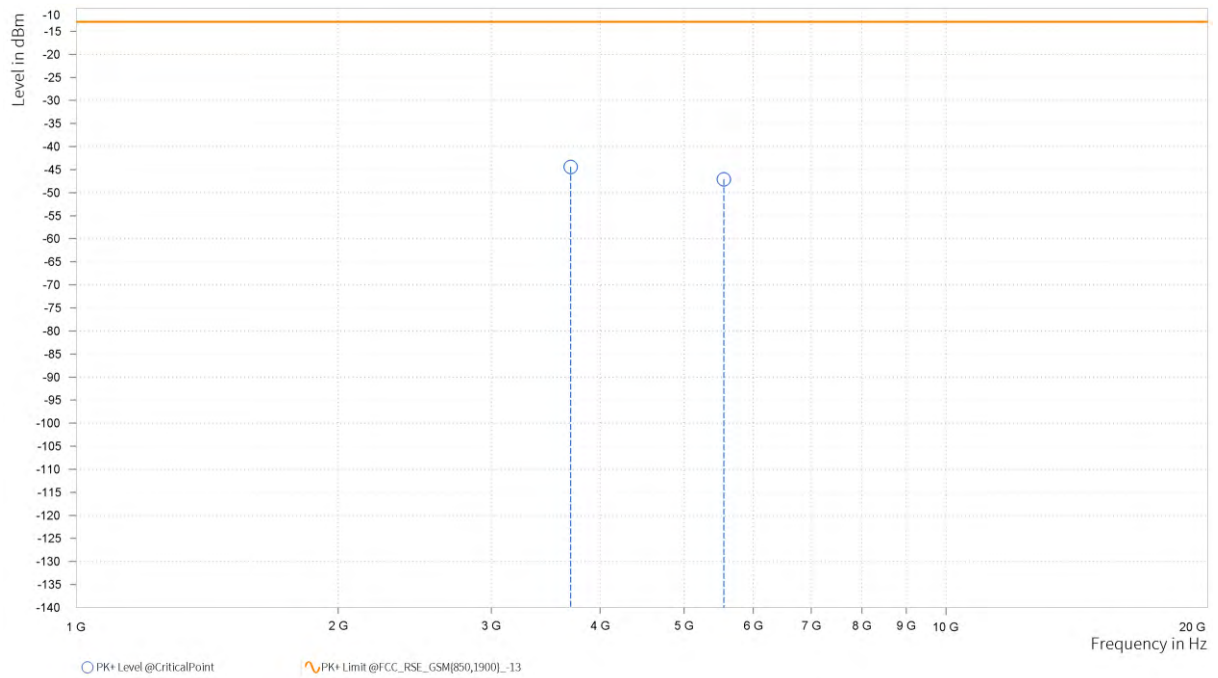



**BUREAU
VERITAS**

Test Report No.: PSU-QSU2312200110RF02

CH 661

MODE	TX channel 661	FREQUENCY RANGE	Above 1000MHz
ENVIRONMENTAL CONDITIONS	23deg. C, 70%RH	INPUT POWER	120Vac 60HZ
TESTED BY	Hanwen Xu		
ANTENNA POLARITY & TEST DISTANCE: HORIZONTAL AT 3 M			

Rg	Frequency [MHz]	PK+ Level [dBm]	PK+ Limit [dBm]	PK+ Margin [dB]	Correction [dB]	Polarization	Azimuth [deg]	Antenna Height [m]
4	3,760.000	-48.87	-13.00	35.87	23.12	H	122.8	2.00
4	5,640.000	-45.48	-13.00	32.48	26.20	H	237.2	1.00

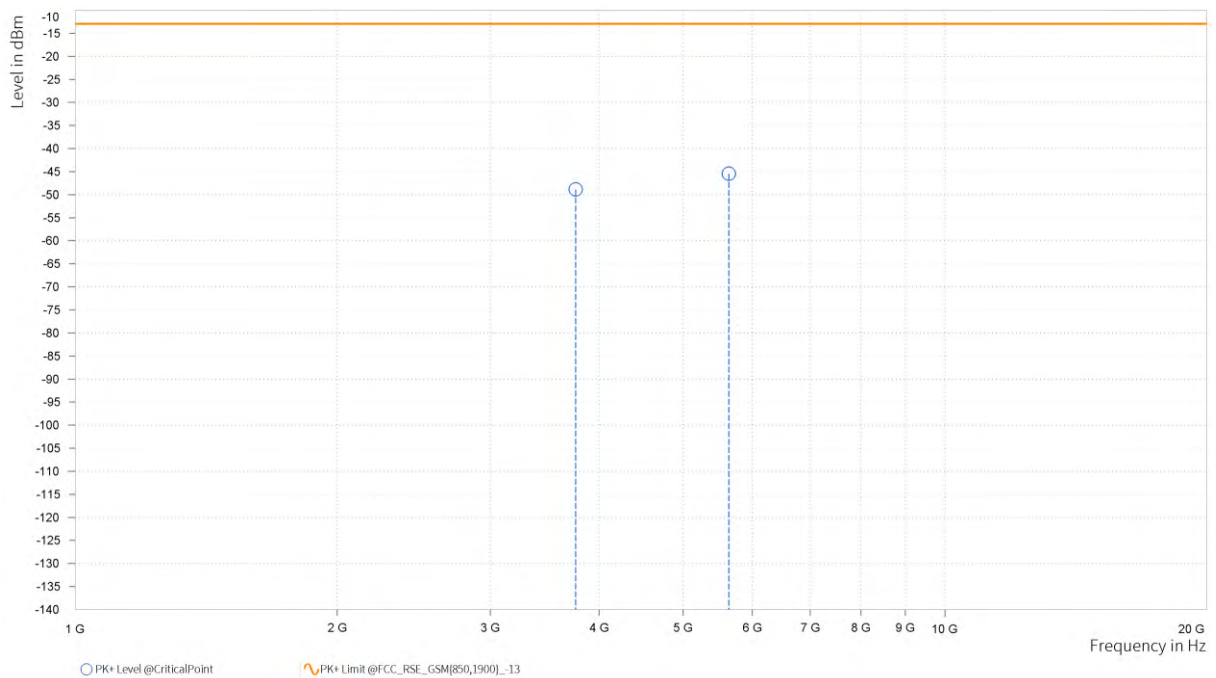



**BUREAU
VERITAS**

Test Report No.: PSU-QSU2312200110RF02

MODE	TX channel 661	FREQUENCY RANGE	Above 1000MHz
ENVIRONMENTAL CONDITIONS	23deg. C, 70%RH	INPUT POWER	120Vac 60HZ
TESTED BY	Hanwen Xu		
ANTENNA POLARITY & TEST DISTANCE: VERTICAL AT 3 M			

Rg	Frequency [MHz]	PK+ Level [dBm]	PK+ Limit [dBm]	PK+ Margin [dB]	Correction [dB]	Polarization	Azimuth [deg]	Antenna Height [m]
4	3,760.000	-47.91	-13.00	34.91	23.61	V	359	2.00
4	5,640.000	-46.65	-13.00	33.65	26.55	V	359	2.00

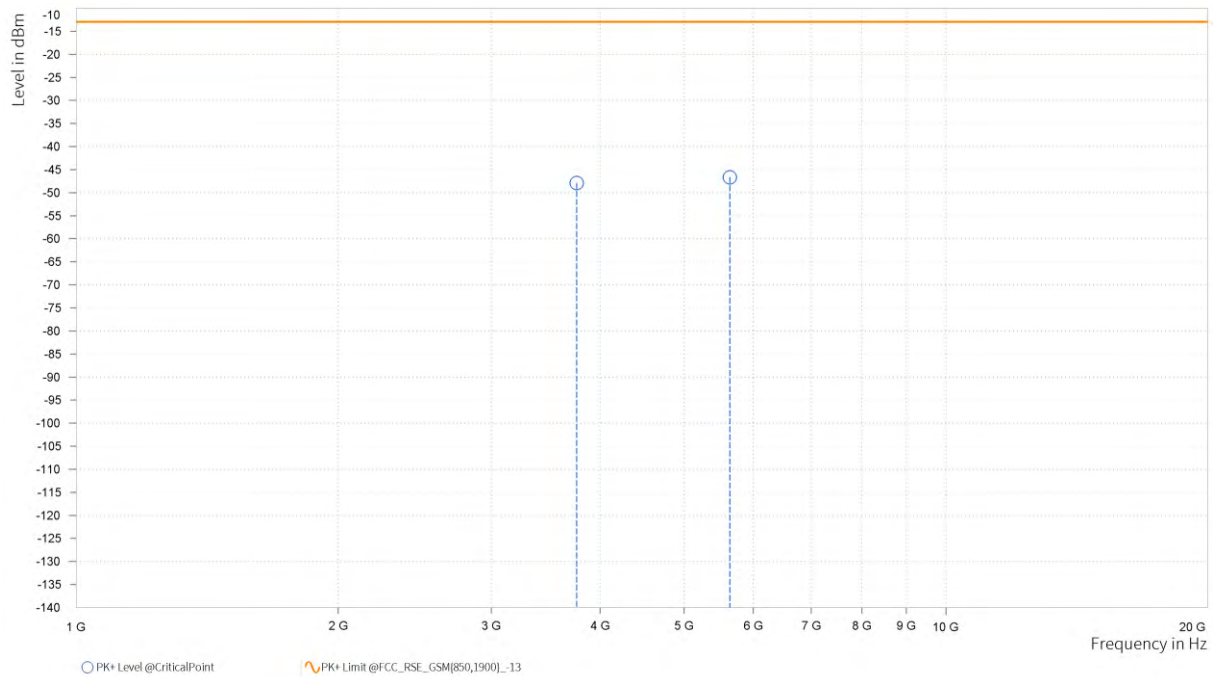



**BUREAU
VERITAS**

Test Report No.: PSU-QSU2312200110RF02

CH 810

MODE	TX channel 810	FREQUENCY RANGE	Above 1000MHz
ENVIRONMENTAL CONDITIONS	23deg. C, 70%RH	INPUT POWER	120Vac 60HZ
TESTED BY	Hanwen Xu		
ANTENNA POLARITY & TEST DISTANCE: HORIZONTAL AT 3 M			

Rg	Frequency [MHz]	PK+ Level [dBm]	PK+ Limit [dBm]	PK+ Margin [dB]	Correction [dB]	Polarization	Azimuth [deg]	Antenna Height [m]
4	3,819.600	-46.33	-13.00	33.33	23.26	H	359	2.00
4	5,729.400	-46.22	-13.00	33.22	26.75	H	1	1.00

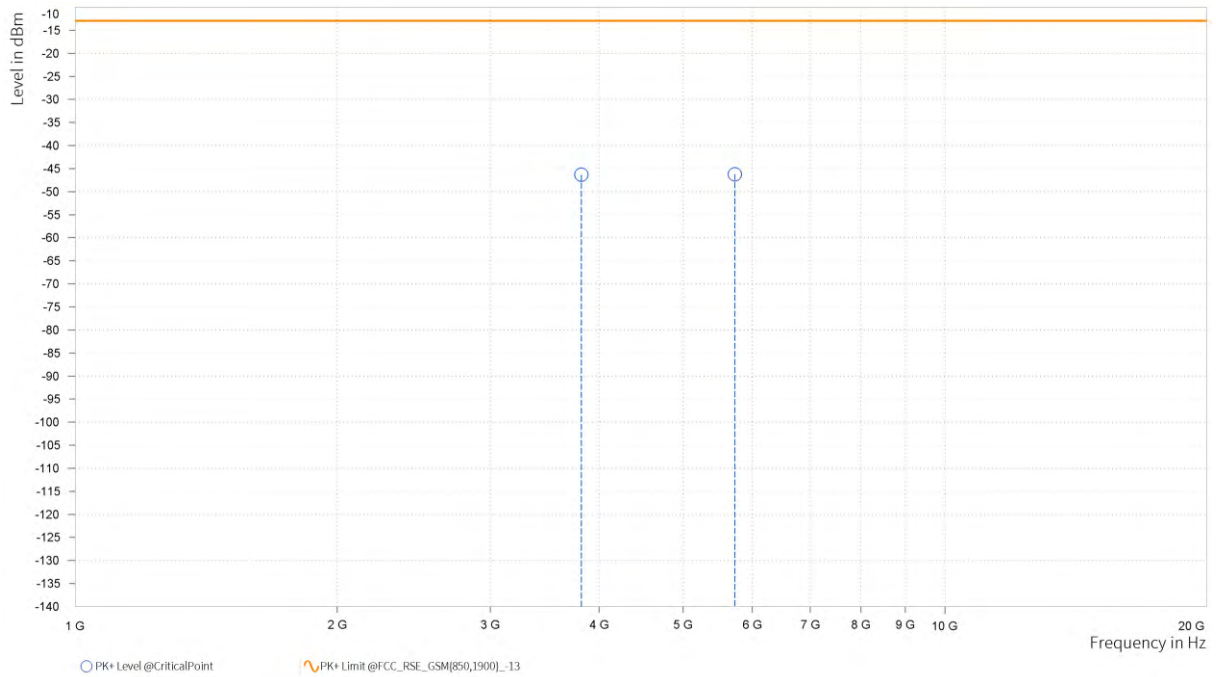



**BUREAU
VERITAS**

Test Report No.: PSU-QSU2312200110RF02

MODE	TX channel 810	FREQUENCY RANGE	Above 1000MHz
ENVIRONMENTAL CONDITIONS	23deg. C, 70%RH	INPUT POWER	120Vac 60HZ
TESTED BY	Hanwen Xu		
ANTENNA POLARITY & TEST DISTANCE: VERTICAL AT 3 M			

Rg	Frequency [MHz]	PK+ Level [dBm]	PK+ Limit [dBm]	PK+ Margin [dB]	Correction [dB]	Polarization	Azimuth [deg]	Antenna Height [m]
4	3,819.600	-45.29	-13.00	32.29	23.61	V	237.1	1.00
4	5,729.400	-45.99	-13.00	32.99	27.21	V	359	1.00

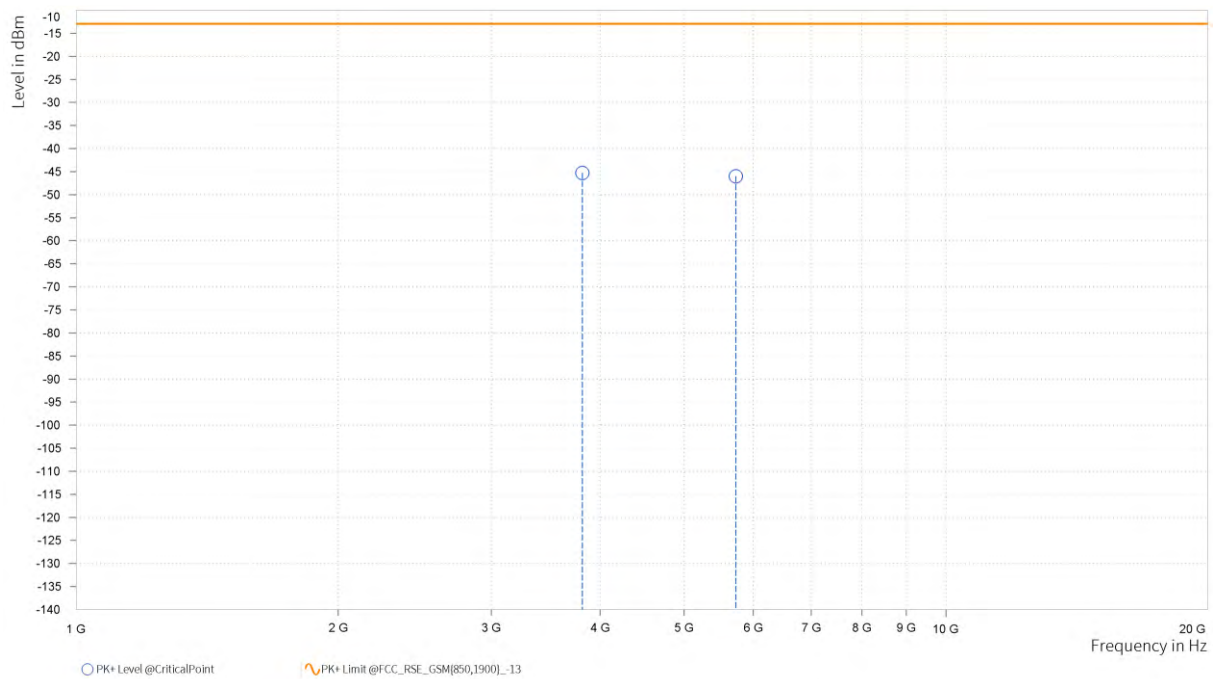



EDGE 1900:

CH 512

MODE	TX channel 512	FREQUENCY RANGE	Above 1000MHz
ENVIRONMENTAL CONDITIONS	23deg. C, 70%RH	INPUT POWER	120Vac 60HZ
TESTED BY	Hanwen Xu		
ANTENNA POLARITY & TEST DISTANCE: HORIZONTAL AT 3 M			

Rg	Frequency [MHz]	PK+ Level [dBm]	PK+ Limit [dBm]	PK+ Margin [dB]	Correction [dB]	Polarization	Azimuth [deg]	Antenna Height [m]
4	3,700.000	-48.58	-13.00	35.58	22.48	H	359.1	1.00
4	5,550.600	-46.94	-13.00	33.94	25.81	H	1	1.00

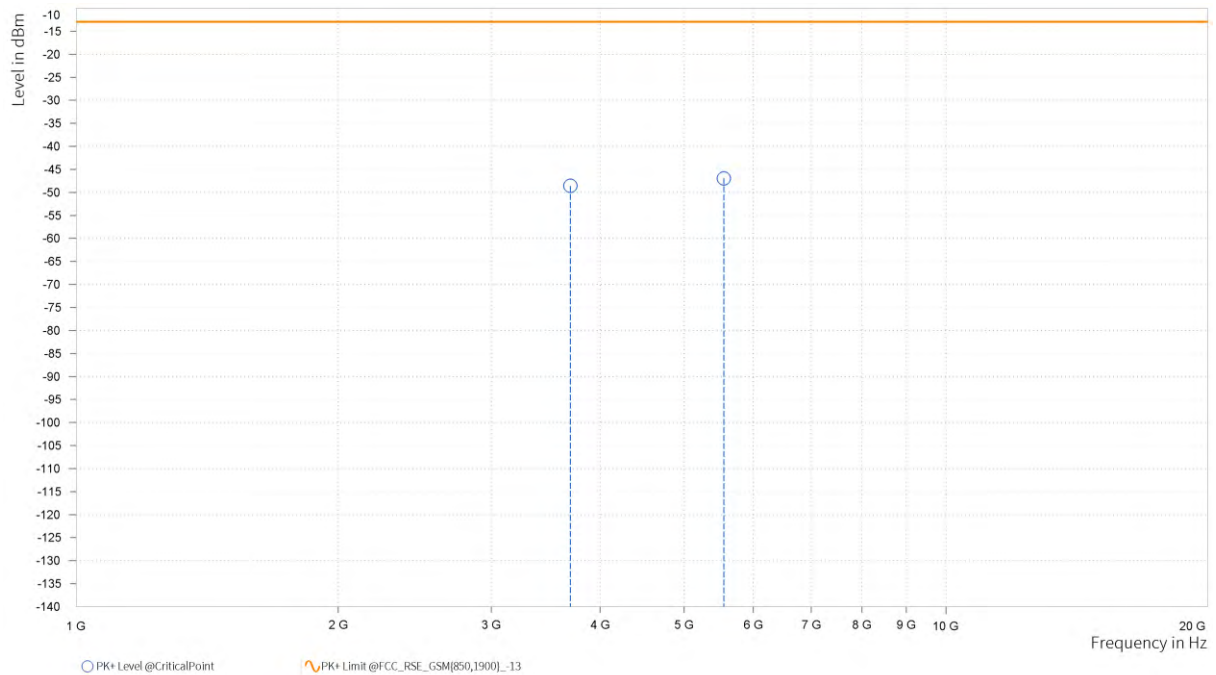



**BUREAU
VERITAS**

Test Report No.: PSU-QSU2312200110RF02

MODE	TX channel 512	FREQUENCY RANGE	Above 1000MHz
ENVIRONMENTAL CONDITIONS	23deg. C, 70%RH	INPUT POWER	120Vac 60HZ
TESTED BY	Hanwen Xu		
ANTENNA POLARITY & TEST DISTANCE: VERTICAL AT 3 M			

Rg	Frequency [MHz]	PK+ Level [dBm]	PK+ Limit [dBm]	PK+ Margin [dB]	Correction [dB]	Polarization	Azimuth [deg]	Antenna Height [m]
4	3,700.500	-43.99	-13.00	30.99	23.07	V	359	2.00
4	5,550.600	-46.11	-13.00	33.11	26.51	V	0.9	2.00

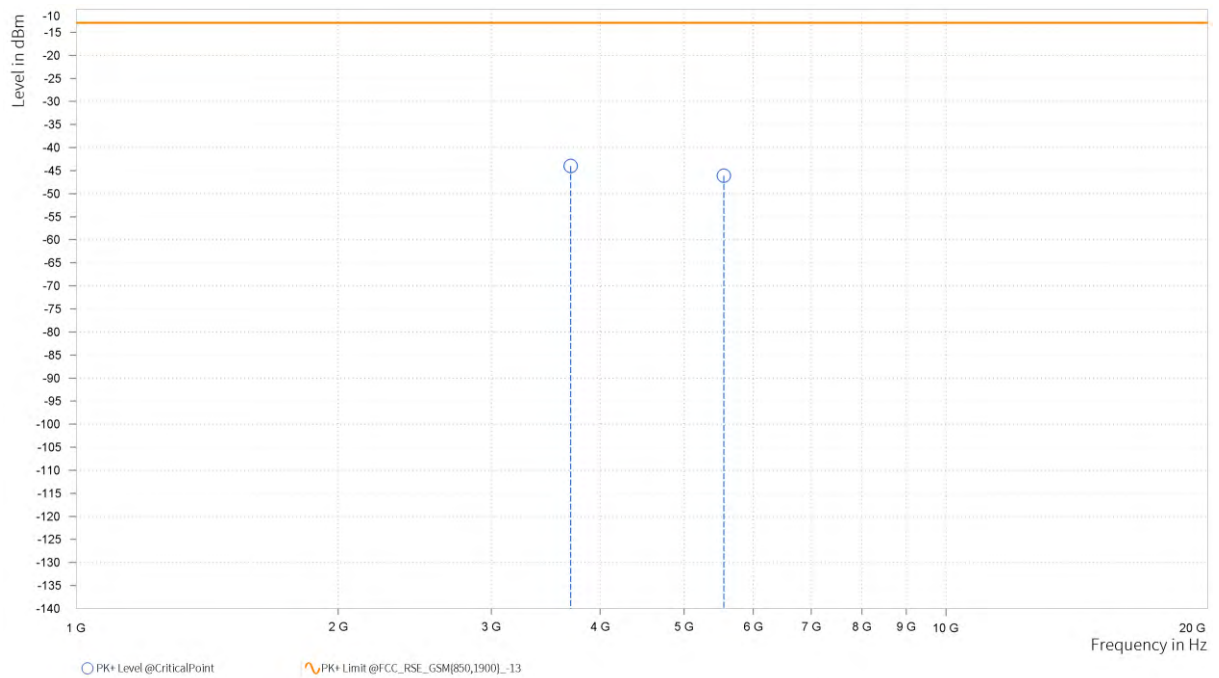



**BUREAU
VERITAS**

Test Report No.: PSU-QSU2312200110RF02

CH 661

MODE	TX channel 661	FREQUENCY RANGE	Above 1000MHz
ENVIRONMENTAL CONDITIONS	23deg. C, 70%RH	INPUT POWER	120Vac 60HZ
TESTED BY	Hanwen Xu		
ANTENNA POLARITY & TEST DISTANCE: HORIZONTAL AT 3 M			

Rg	Frequency [MHz]	PK+ Level [dBm]	PK+ Limit [dBm]	PK+ Margin [dB]	Correction [dB]	Polarization	Azimuth [deg]	Antenna Height [m]
4	3,760.000	-47.81	-13.00	34.81	23.12	H	1	1.00
4	5,640.000	-45.82	-13.00	32.82	26.20	H	1	2.00

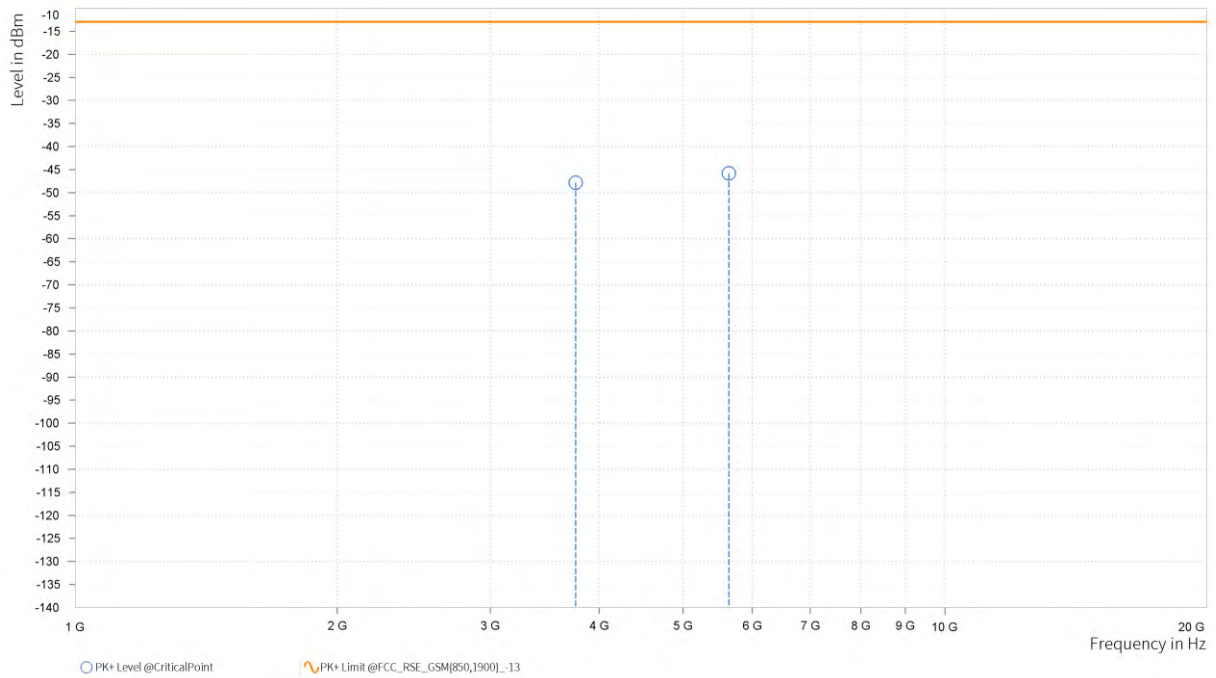



**BUREAU
VERITAS**

Test Report No.: PSU-QSU2312200110RF02

MODE	TX channel 661	FREQUENCY RANGE	Above 1000MHz
ENVIRONMENTAL CONDITIONS	23deg. C, 70%RH	INPUT POWER	120Vac 60HZ
TESTED BY	Hanwen Xu		
ANTENNA POLARITY & TEST DISTANCE: VERTICAL AT 3 M			

Rg	Frequency [MHz]	PK+ Level [dBm]	PK+ Limit [dBm]	PK+ Margin [dB]	Correction [dB]	Polarization	Azimuth [deg]	Antenna Height [m]
4	3,760.000	-48.67	-13.00	35.67	23.61	V	359	1.00
4	5,640.000	-46.01	-13.00	33.01	26.55	V	359	1.00

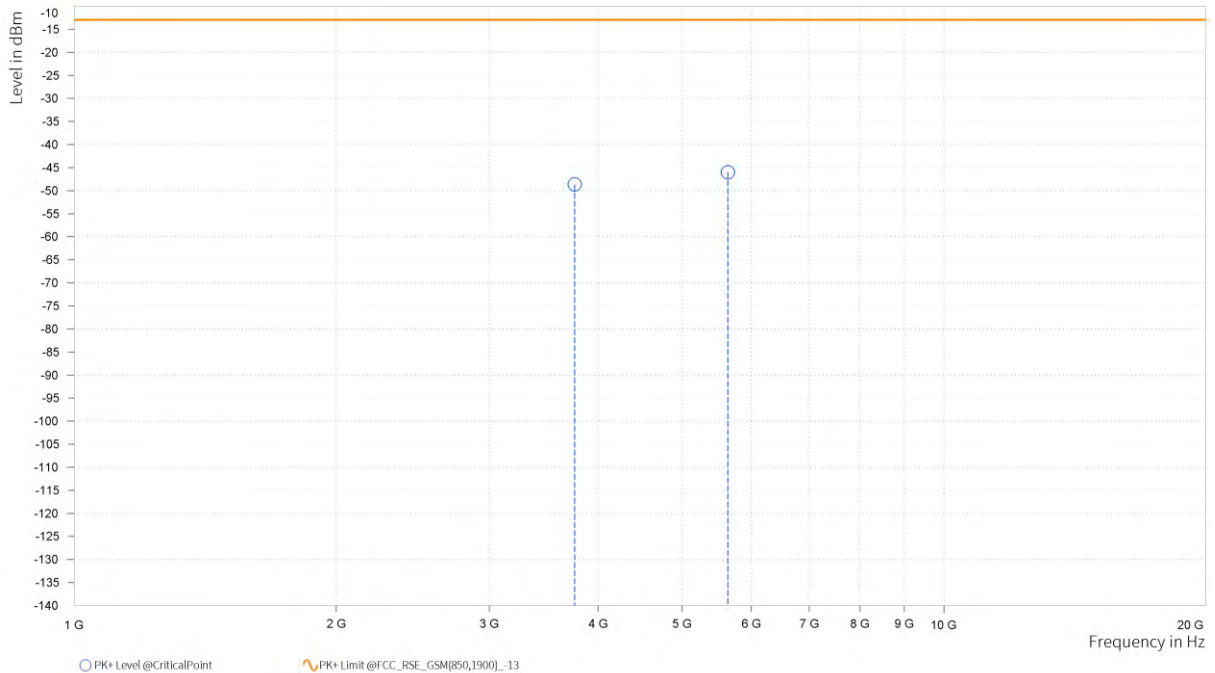



**BUREAU
VERITAS**

Test Report No.: PSU-QSU2312200110RF02

CH 810

MODE	TX channel 810	FREQUENCY RANGE	Above 1000MHz
ENVIRONMENTAL CONDITIONS	23deg. C, 70%RH	INPUT POWER	120Vac 60HZ
TESTED BY	Hanwen Xu		
ANTENNA POLARITY & TEST DISTANCE: HORIZONTAL AT 3 M			

Rg	Frequency [MHz]	PK+ Level [dBm]	PK+ Limit [dBm]	PK+ Margin [dB]	Correction [dB]	Polarization	Azimuth [deg]	Antenna Height [m]
4	3,819.600	-46.06	-13.00	33.06	23.26	H	359	2.00
4	5,729.400	-46.41	-13.00	33.41	26.75	H	120.4	2.00

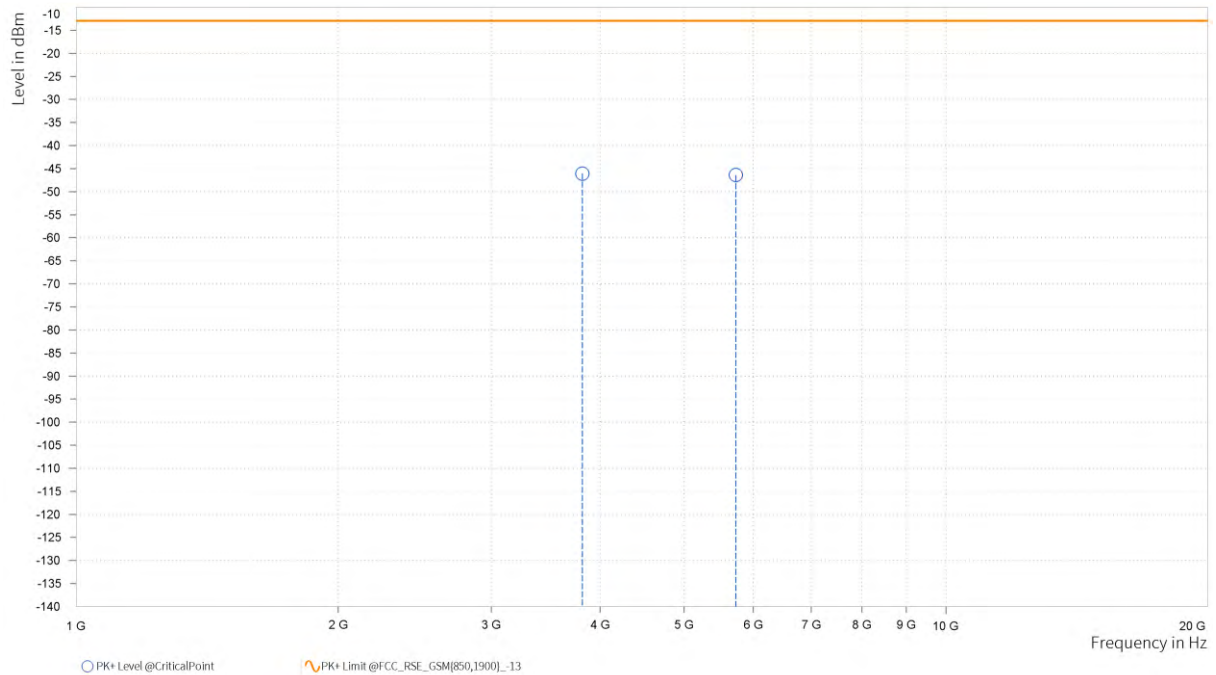



**BUREAU
VERITAS**

Test Report No.: PSU-QSU2312200110RF02

MODE	TX channel 810	FREQUENCY RANGE	Above 1000MHz
ENVIRONMENTAL CONDITIONS	23deg. C, 70%RH	INPUT POWER	120Vac 60HZ
TESTED BY	Hanwen Xu		
ANTENNA POLARITY & TEST DISTANCE: VERTICAL AT 3 M			

Rg	Frequency [MHz]	PK+ Level [dBm]	PK+ Limit [dBm]	PK+ Margin [dB]	Correction [dB]	Polarization	Azimuth [deg]	Antenna Height [m]
4	3,819.600	-46.43	-13.00	33.43	23.61	V	0.9	2.00
4	5,729.400	-46.59	-13.00	33.59	27.21	V	359.1	1.00

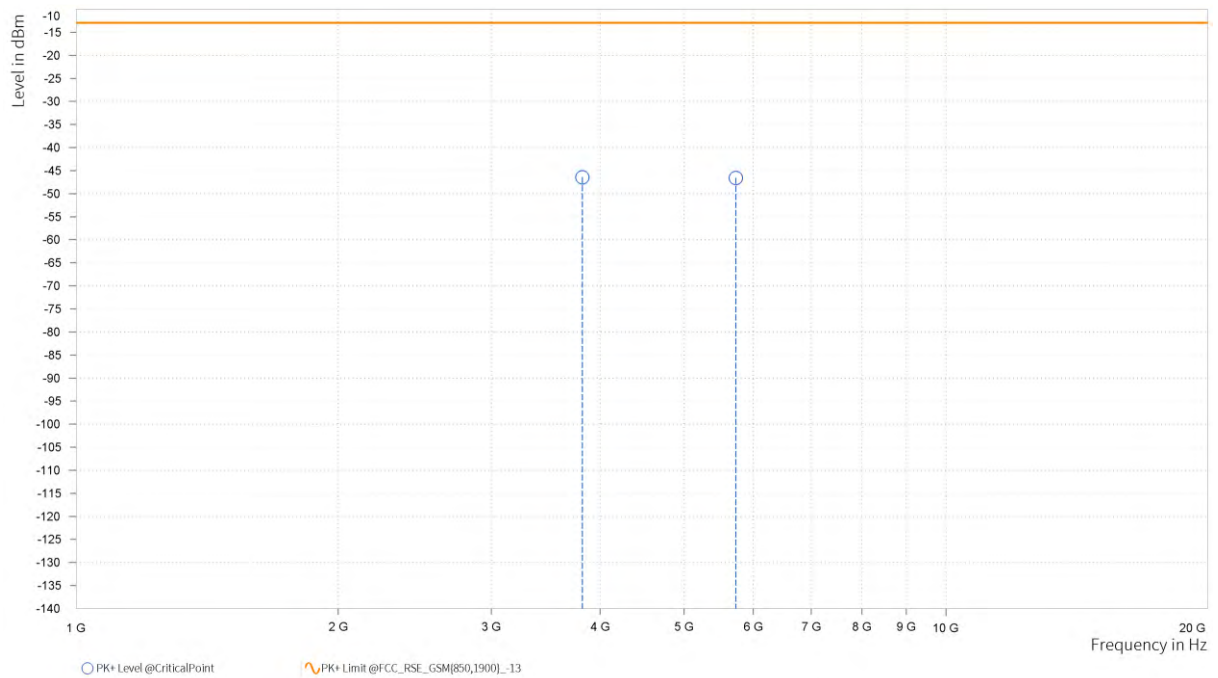



CDMA2000 BC1:

CH 25

MODE	TX channel 25	FREQUENCY RANGE	Above 1000MHz
ENVIRONMENTAL CONDITIONS	23deg. C, 70%RH	INPUT POWER	120Vac 60HZ
TESTED BY	Jace Hu		
ANTENNA POLARITY & TEST DISTANCE: HORIZONTAL AT 3 M			

	Freq	Level	Read Level	Limit Line	Over Limit	Factor	Remark	Pol/Phase
	MHz	dBm/m	dBm	dBm/m	dB	dB/m		
1	3698.000	-51.42	-59.82	-13.00	-38.42	8.40	Peak	Horizontal
2 PP	5553.750	-49.58	-61.38	-13.00	-36.58	11.80	Peak	Horizontal

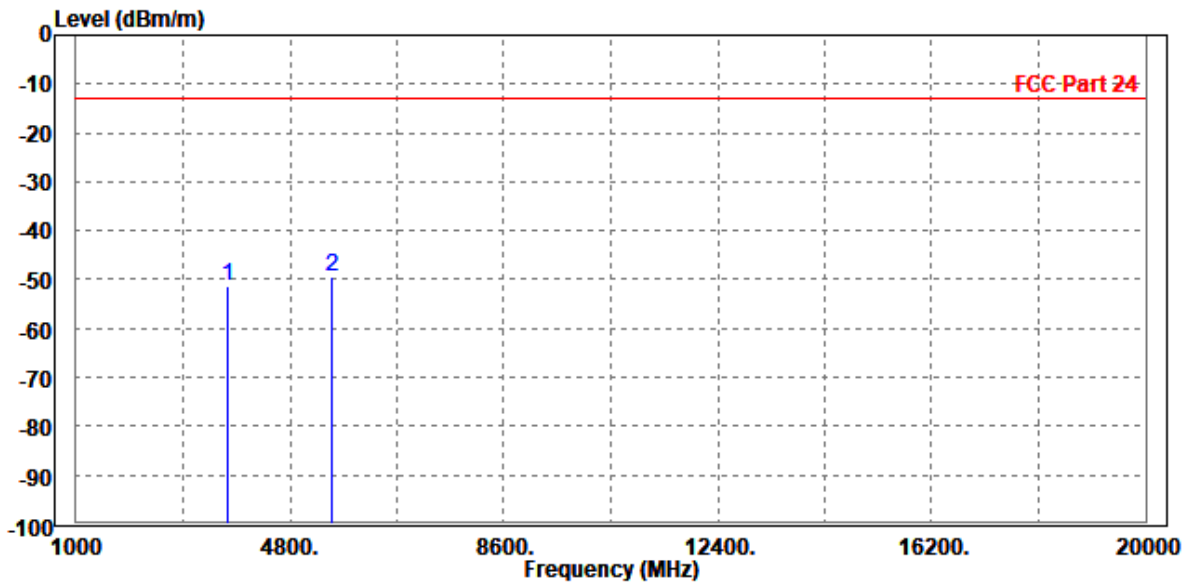



**BUREAU
VERITAS**

Test Report No.: PSU-QSU2312200110RF02

MODE	TX channel 25	FREQUENCY RANGE	Above 1000MHz
ENVIRONMENTAL CONDITIONS	23deg. C, 70%RH	INPUT POWER	120Vac 60HZ
TESTED BY	Jace Hu		
ANTENNA POLARITY & TEST DISTANCE: VERTICAL AT 3 M			

	Freq	Level	Read Level	Limit Line	Over Limit	Factor	Remark	Pol/Phase
	MHz	dBm/m	dBm	dBm/m	dB	dB/m		
1	3702.500	-51.31	-59.94	-13.00	-38.31	8.63	Peak	Vertical
2 PP	5560.000	-48.86	-61.19	-13.00	-35.86	12.33	Peak	Vertical

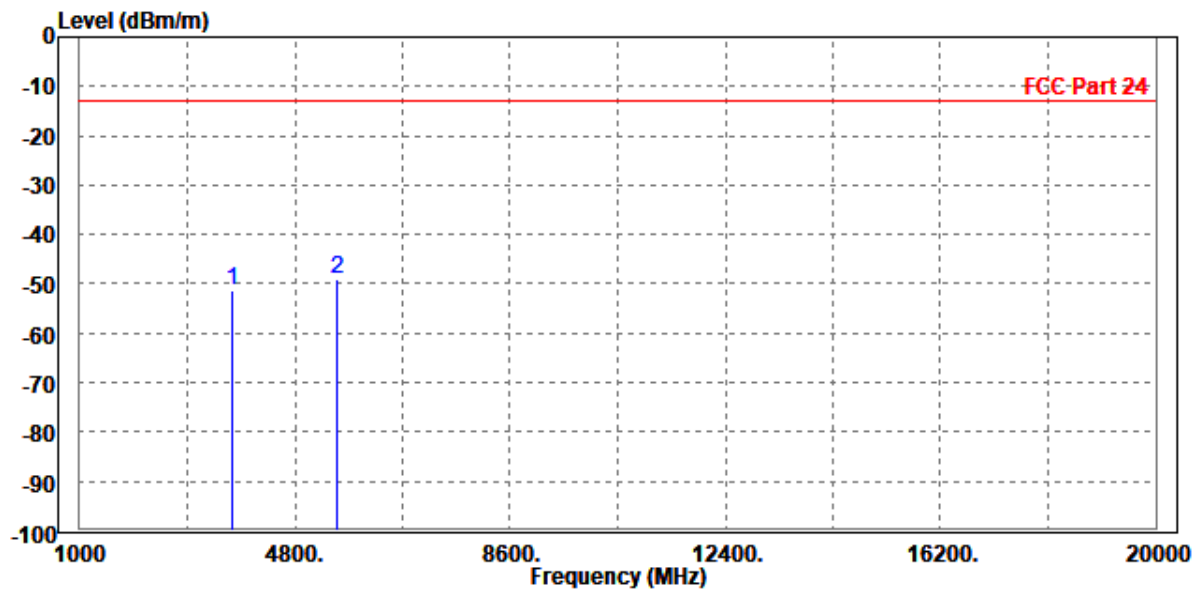



**BUREAU
VERITAS**

Test Report No.: PSU-QSU2312200110RF02

CH 600

MODE	TX channel 600	FREQUENCY RANGE	Above 1000MHz
ENVIRONMENTAL CONDITIONS	23deg. C, 70%RH	INPUT POWER	120Vac 60HZ
TESTED BY	Jace Hu		
ANTENNA POLARITY & TEST DISTANCE: HORIZONTAL AT 3 M			

	Freq	Level	Read Level	Limit Line	Over Limit	Factor	Remark	Pol/Phase
	MHz	dBm/m	dBm	dBm/m	dB	dB/m		
1	3755.000	-51.24	-59.60	-13.00	-38.24	8.36	Peak	Horizontal
2 PP	5640.000	-50.34	-62.15	-13.00	-37.34	11.81	Peak	Horizontal

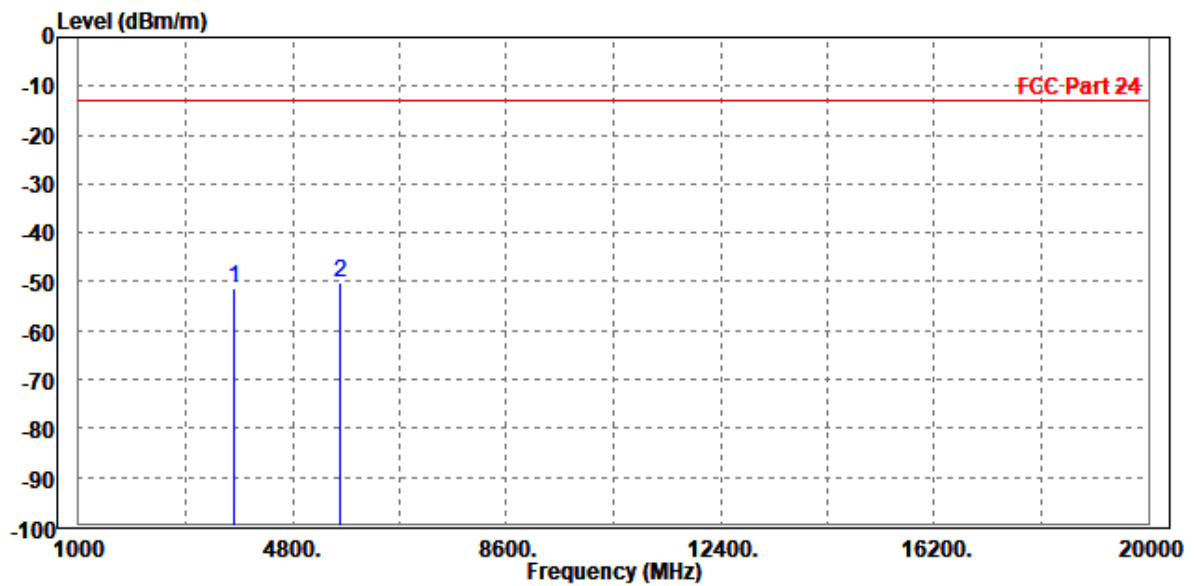



**BUREAU
VERITAS**

Test Report No.: PSU-QSU2312200110RF02

MODE	TX channel 600	FREQUENCY RANGE	Above 1000MHz
ENVIRONMENTAL CONDITIONS	23deg. C, 70%RH	INPUT POWER	120Vac 60HZ
TESTED BY	Jace Hu		
ANTENNA POLARITY & TEST DISTANCE: VERTICAL AT 3 M			

	Freq	Level	Read Level	Limit Line	Over Limit	Factor	Remark	Pol/Phase
	MHz	dBm/m	dBm	dBm/m	dB	dB/m		
1	3760.000	-51.50	-60.13	-13.00	-38.50	8.63	Peak	Vertical
2 PP	5636.000	-47.67	-59.99	-13.00	-34.67	12.32	Peak	Vertical

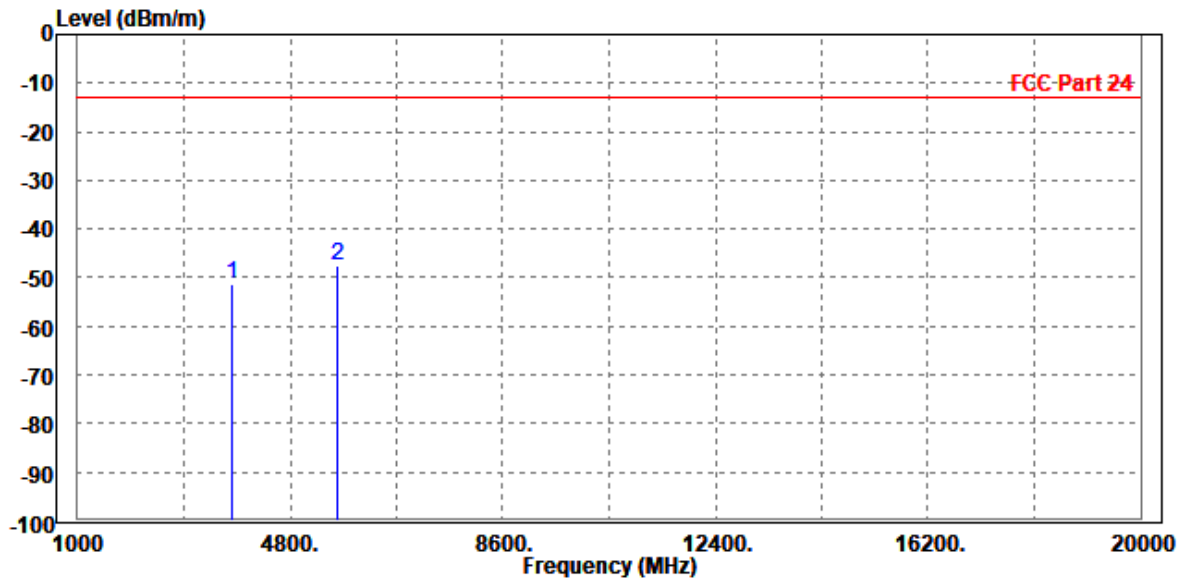



CH 1175

MODE	TX channel 1175	FREQUENCY RANGE	Above 1000MHz
ENVIRONMENTAL CONDITIONS	23deg. C, 70%RH	INPUT POWER	120Vac 60HZ
TESTED BY	Jace Hu		
ANTENNA POLARITY & TEST DISTANCE: HORIZONTAL AT 3 M			

	Freq	Level	Read Level	Limit Line	Over Limit	Factor	Remark	Pol/Phase
	MHz	dBm/m	dBm	dBm/m	dB	dB/m		
1	3817.500	-51.16	-59.47	-13.00	-38.16	8.31	Peak	Horizontal
2 PP	5731.000	-50.08	-61.90	-13.00	-37.08	11.82	Peak	Horizontal

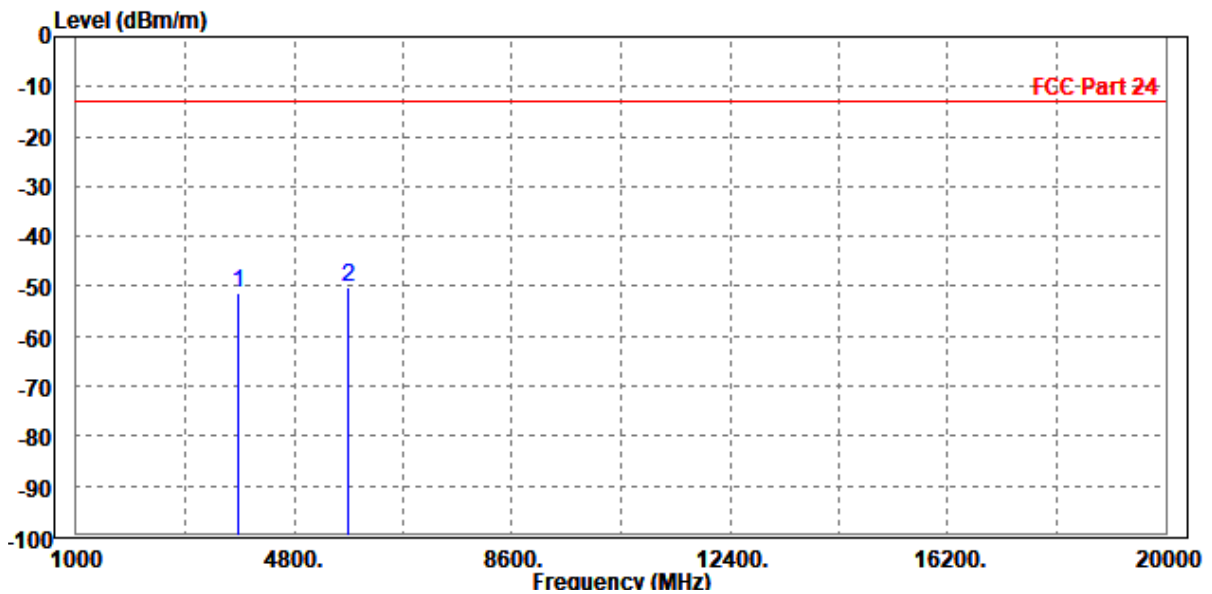



**BUREAU
VERITAS**

Test Report No.: PSU-QSU2312200110RF02

MODE	TX channel 1175	FREQUENCY RANGE	Above 1000MHz
ENVIRONMENTAL CONDITIONS	23deg. C, 70%RH	INPUT POWER	120Vac 60HZ
TESTED BY	Jace Hu		
ANTENNA POLARITY & TEST DISTANCE: VERTICAL AT 3 M			

	Freq	Level	Read Level	Limit Line	Over Limit	Factor	Remark	Pol/Phase
	MHz	dBm/m	dBm	dBm/m	dB	dB/m		
1	3812.000	-50.99	-59.62	-13.00	-37.99	8.63	Peak	Vertical
2	PP 5726.250	-49.12	-61.43	-13.00	-36.12	12.31	Peak	Vertical

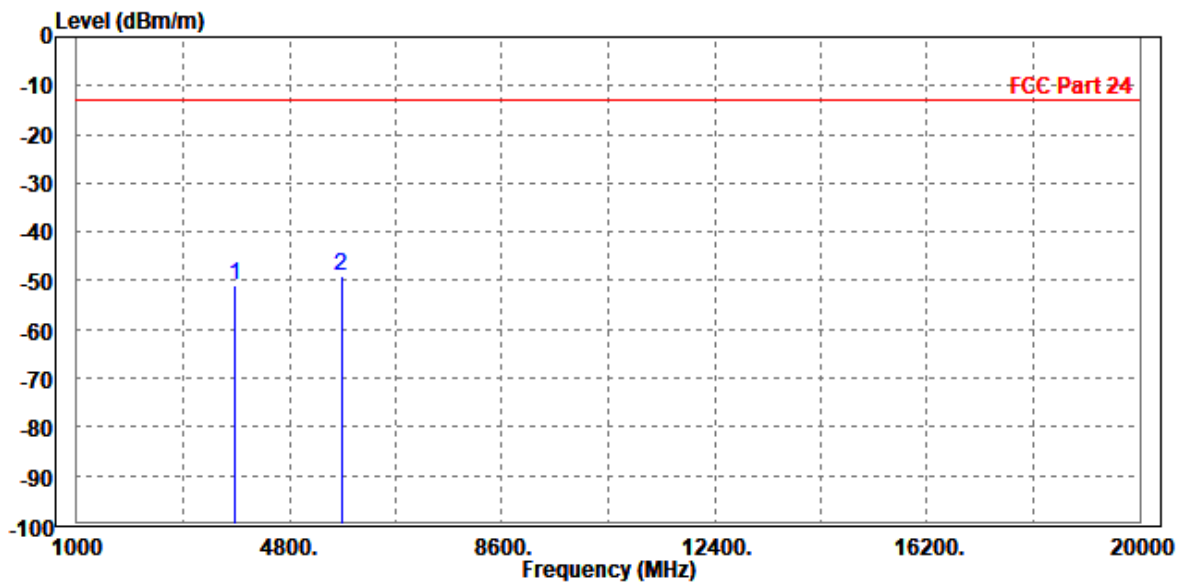



**BUREAU
VERITAS**

Test Report No.: PSU-QSU2312200110RF02

WCDMA Band II

CH 9262

MODE	TX channel 9262	FREQUENCY RANGE	Above 1000MHz
ENVIRONMENTAL CONDITIONS	23deg. C, 70%RH	INPUT POWER	120Vac 60HZ
TESTED BY	Hanwen Xu		
ANTENNA POLARITY & TEST DISTANCE: HORIZONTAL AT 3 M			

Rg	Frequency [MHz]	PK+ Level [dBm]	PK+ Limit [dBm]	PK+ Margin [dB]	Correction [dB]	Polarization	Azimuth [deg]	Antenna Height [m]
4	3,704.800	-46.85	-13.00	33.85	24.99	H	205.1	1
4	5,557.200	-46.94	-13.00	33.94	27.51	H	155	2

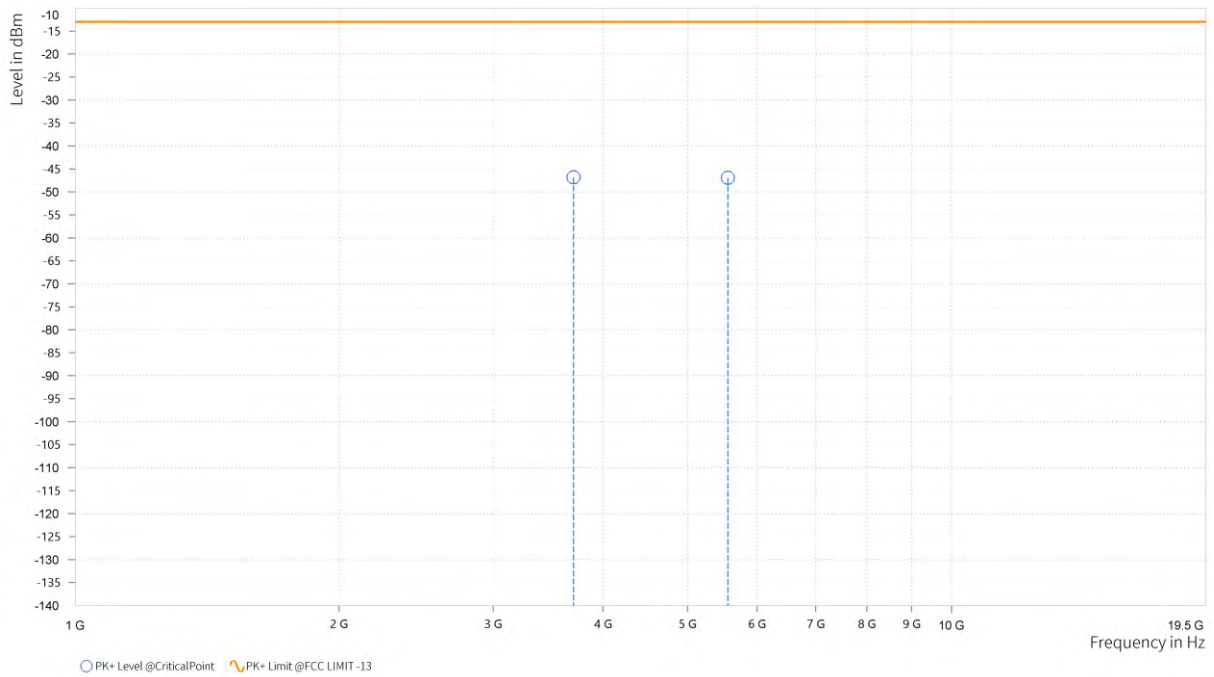



**BUREAU
VERITAS**

Test Report No.: PSU-QSU2312200110RF02

MODE	TX channel 9262	FREQUENCY RANGE	Above 1000MHz
ENVIRONMENTAL CONDITIONS	23deg. C, 70%RH	INPUT POWER	120Vac 60HZ
TESTED BY	Hanwen Xu		
ANTENNA POLARITY & TEST DISTANCE: VERTICAL AT 3 M			

Rg	Frequency [MHz]	PK+ Level [dBm]	PK+ Limit [dBm]	PK+ Margin [dB]	Correction [dB]	Polarization	Azimuth [deg]	Antenna Height [m]
4	3,704.800	-45.39	-13.00	32.39	24.85	V	359	1
4	5,557.200	-46.96	-13.00	33.96	27.25	V	152.5	2

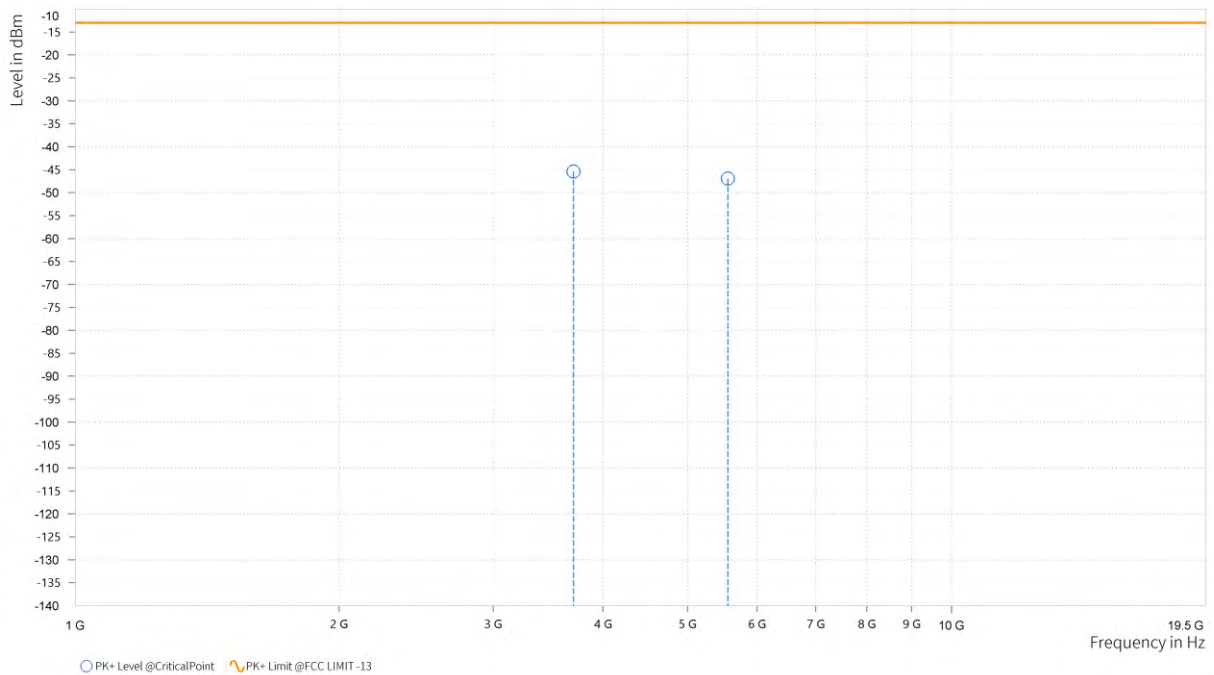



**BUREAU
VERITAS**

Test Report No.: PSU-QSU2312200110RF02

CH 9400

MODE	TX channel 9400	FREQUENCY RANGE	Above 1000MHz
ENVIRONMENTAL CONDITIONS	23deg. C, 70%RH	INPUT POWER	120Vac 60HZ
TESTED BY	Hanwen Xu		
ANTENNA POLARITY & TEST DISTANCE: HORIZONTAL AT 3 M			

Rg	Frequency [MHz]	PK+ Level [dBm]	PK+ Limit [dBm]	PK+ Margin [dB]	Correction [dB]	Polarization	Azimuth [deg]	Antenna Height [m]
4	3,760.000	-43.86	-13.00	30.86	25.77	H	155	2
4	5,640.000	-46.47	-13.00	33.47	26.93	H	205.1	1

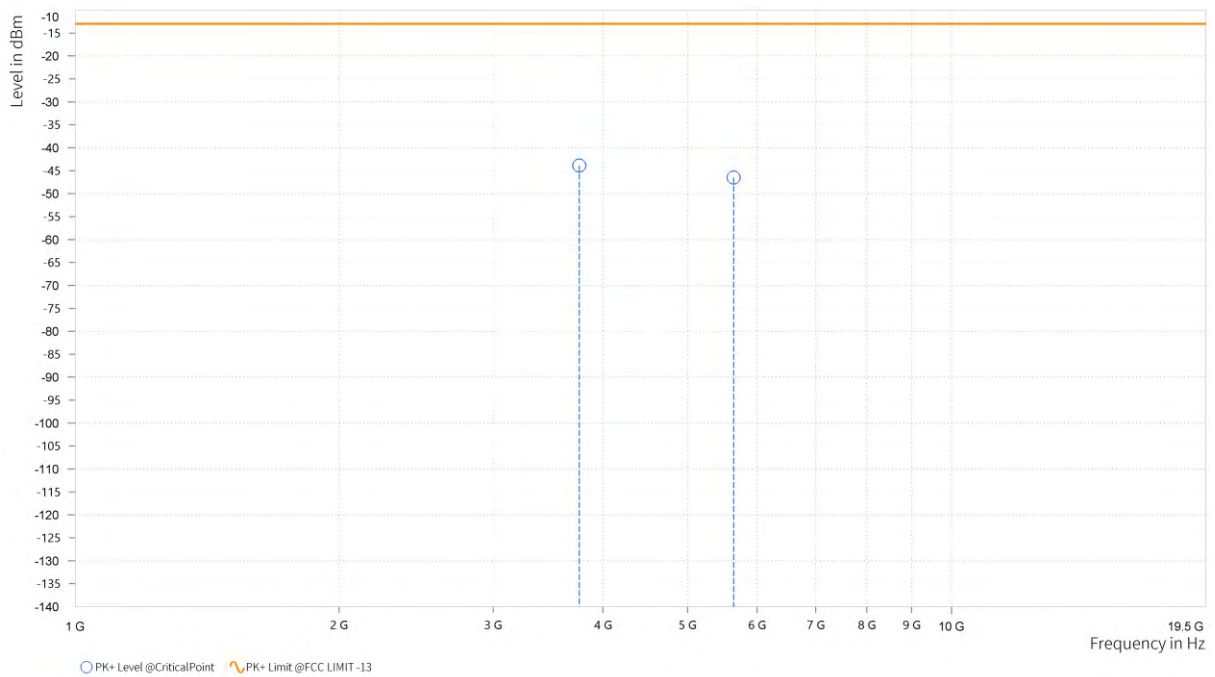



**BUREAU
VERITAS**

Test Report No.: PSU-QSU2312200110RF02

MODE	TX channel 9400	FREQUENCY RANGE	Above 1000MHz
ENVIRONMENTAL CONDITIONS	23deg. C, 70%RH	INPUT POWER	120Vac 60HZ
TESTED BY	Hanwen Xu		
ANTENNA POLARITY & TEST DISTANCE: VERTICAL AT 3 M			

Rg	Frequency [MHz]	PK+ Level [dBm]	PK+ Limit [dBm]	PK+ Margin [dB]	Correction [dB]	Polarization	Azimuth [deg]	Antenna Height [m]
4	3,760.000	-46.00	-13.00	33.00	25.45	V	1	1
4	5,640.000	-47.81	-13.00	34.81	26.70	V	359.1	1

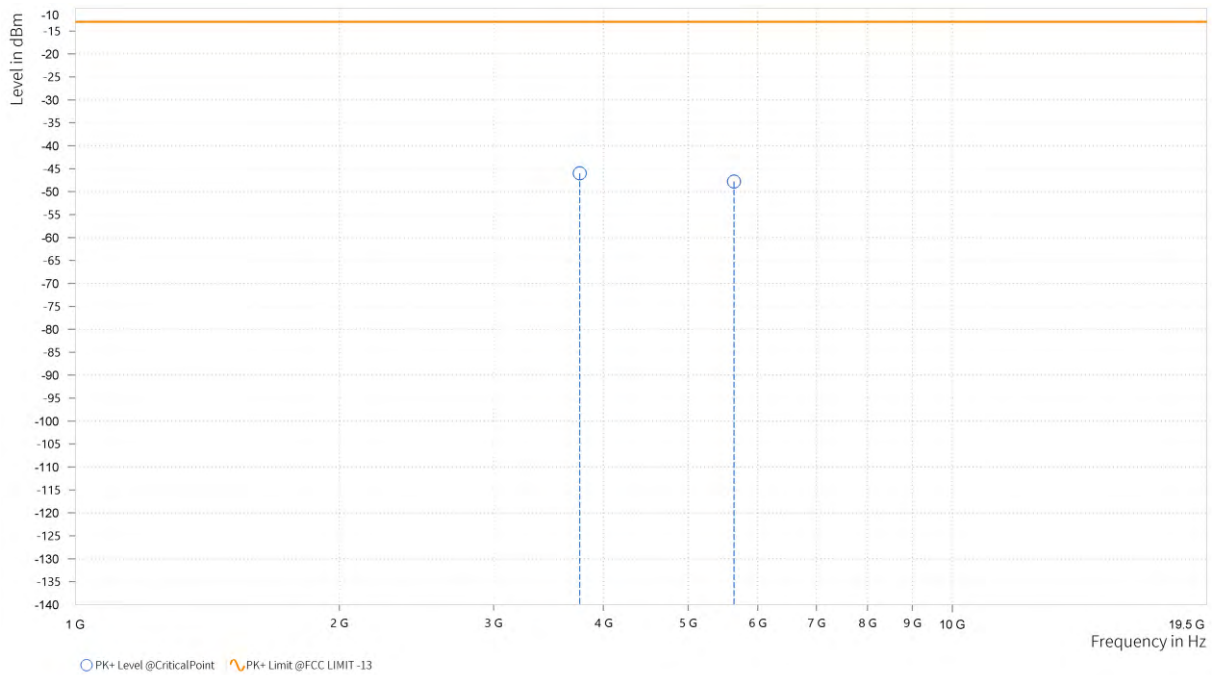



CH 9538

MODE	TX channel 9538	FREQUENCY RANGE	Above 1000MHz
ENVIRONMENTAL CONDITIONS	23deg. C, 70%RH	INPUT POWER	120Vac 60HZ
TESTED BY	Hanwen Xu		
ANTENNA POLARITY & TEST DISTANCE: HORIZONTAL AT 3 M			

Rg	Frequency [MHz]	PK+ Level [dBm]	PK+ Limit [dBm]	PK+ Margin [dB]	Correction [dB]	Polarization	Azimuth [deg]	Antenna Height [m]
4	3,815.200	-45.24	-13.00	32.24	25.42	H	359	2
4	5,722.800	-44.74	-13.00	31.74	27.86	H	156.2	2

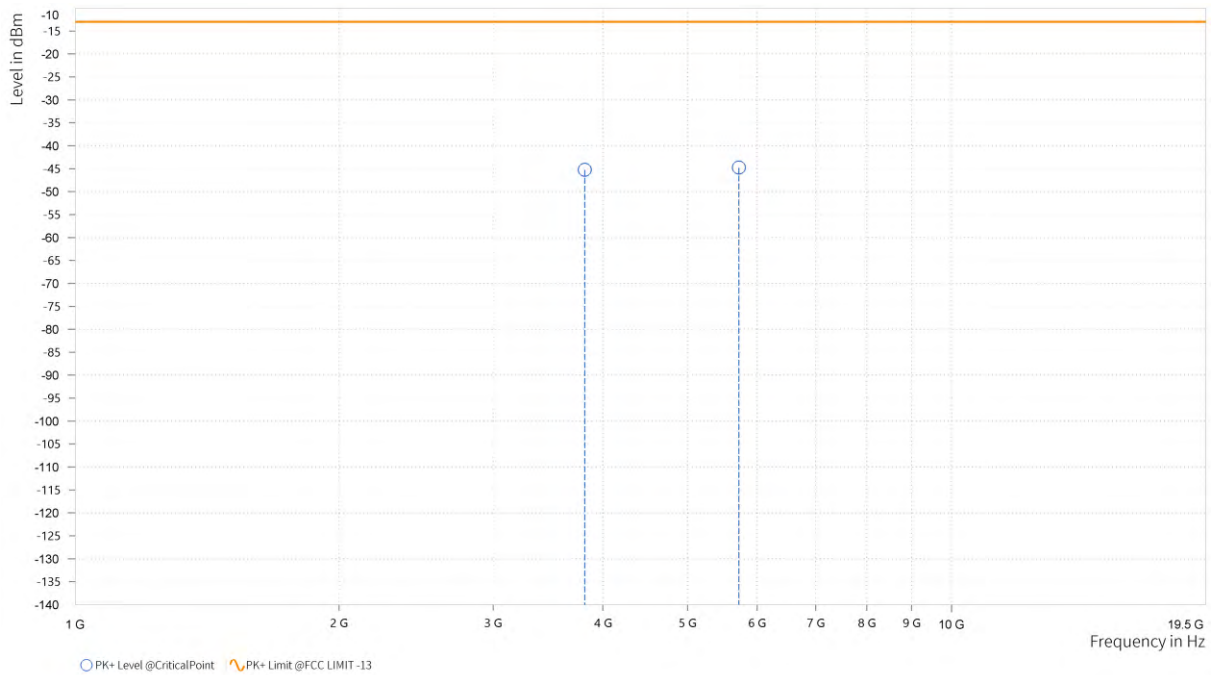



**BUREAU
VERITAS**

Test Report No.: PSU-QSU2312200110RF02

MODE	TX channel 9538	FREQUENCY RANGE	Above 1000MHz
ENVIRONMENTAL CONDITIONS	23deg. C, 70%RH	INPUT POWER	120Vac 60HZ
TESTED BY	Hanwen Xu		
ANTENNA POLARITY & TEST DISTANCE: VERTICAL AT 3 M			

Rg	Frequency [MHz]	PK+ Level [dBm]	PK+ Limit [dBm]	PK+ Margin [dB]	Correction [dB]	Polarization	Azimuth [deg]	Antenna Height [m]
4	3,815.200	-44.76	-13.00	31.76	25.13	V	193.1	1
4	5,722.800	-44.66	-13.00	31.66	27.60	V	1	1

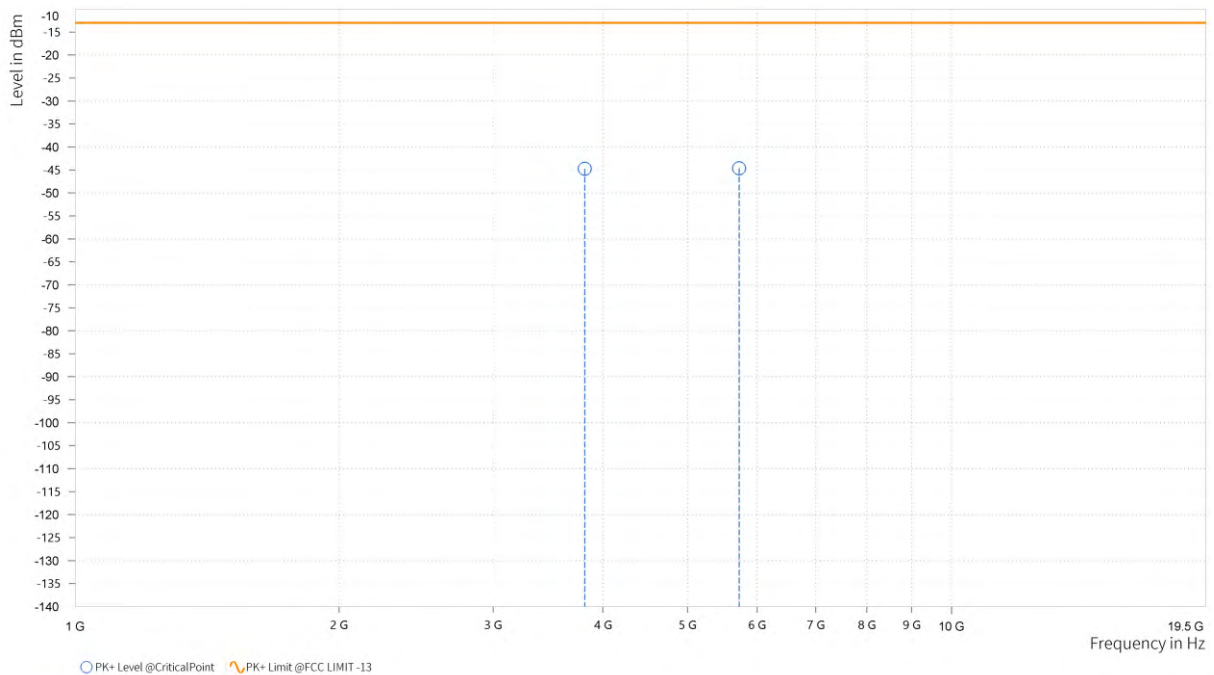



BUREAU VERITAS

Test Report No.: PSU-QSU2312200110RF02

LTE Band 2

CHANNEL BANDWIDTH: 1.4MHz / QPSK

CH18607

MODE	TX channel 18607	FREQUENCY RANGE	Above 1000MHz
ENVIRONMENTAL CONDITIONS	23deg. C, 70%RH	INPUT POWER	120Vac 60HZ
TESTED BY	Hanwen Xu		
ANTENNA POLARITY & TEST DISTANCE: HORIZONTAL AT 3 M			

Rg	Frequency [MHz]	PK+ Level [dBm]	PK+ Limit [dBm]	PK+ Margin [dB]	Correction [dB]	Polarization	Azimuth [deg]	Antenna Height [m]
4	3,718.740	-47.70	-13.00	34.70	25.46	H	1	1
4	5,578.110	-47.76	-13.00	34.76	26.63	H	359	1

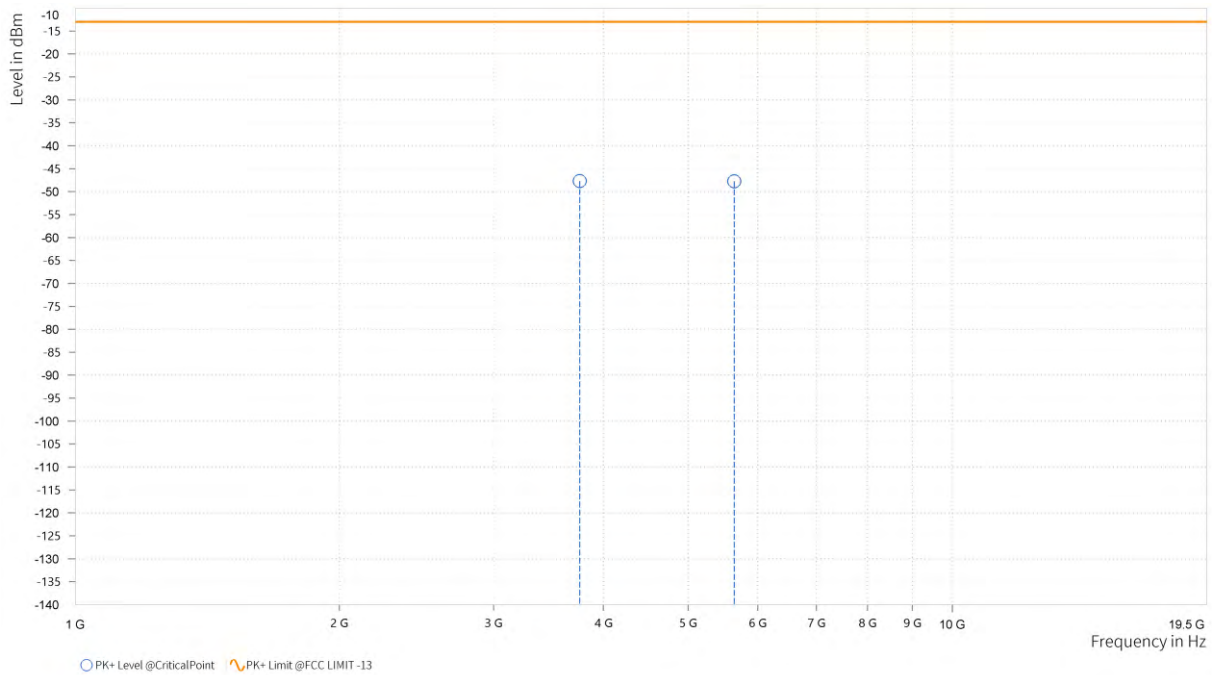



**BUREAU
VERITAS**

Test Report No.: PSU-QSU2312200110RF02

MODE	TX channel 18607	FREQUENCY RANGE	Above 1000MHz
ENVIRONMENTAL CONDITIONS	23deg. C, 70%RH	INPUT POWER	120Vac 60HZ
TESTED BY	Hanwen Xu		
ANTENNA POLARITY & TEST DISTANCE: VERTICAL AT 3 M			

Rg	Frequency [MHz]	PK+ Level [dBm]	PK+ Limit [dBm]	PK+ Margin [dB]	Correction [dB]	Polarization	Azimuth [deg]	Antenna Height [m]
4	3,718.740	-47.21	-13.00	34.21	25.45	V	1	2
4	5,578.110	-47.28	-13.00	34.28	26.63	V	359	1

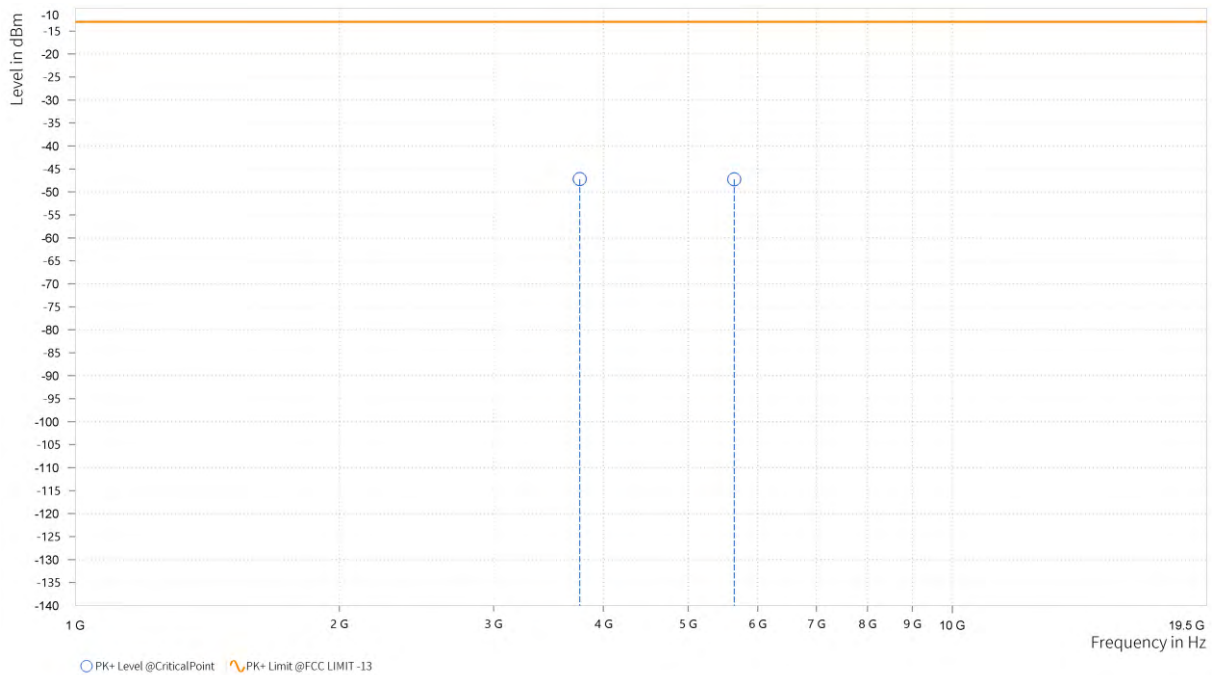



**BUREAU
VERITAS**

Test Report No.: PSU-QSU2312200110RF02

CH18900

MODE	TX channel 18900	FREQUENCY RANGE	Above 1000MHz
ENVIRONMENTAL CONDITIONS	23deg. C, 70%RH	INPUT POWER	120Vac 60HZ
TESTED BY	Hanwen Xu		
ANTENNA POLARITY & TEST DISTANCE: HORIZONTAL AT 3 M			

Rg	Frequency [MHz]	PK+ Level [dBm]	PK+ Limit [dBm]	PK+ Margin [dB]	Correction [dB]	Polarization	Azimuth [deg]	Antenna Height [m]
4	3,758.740	-47.45	-13.00	34.45	25.77	H	1	1
4	5,638.110	-46.58	-13.00	33.58	26.95	H	159.8	2

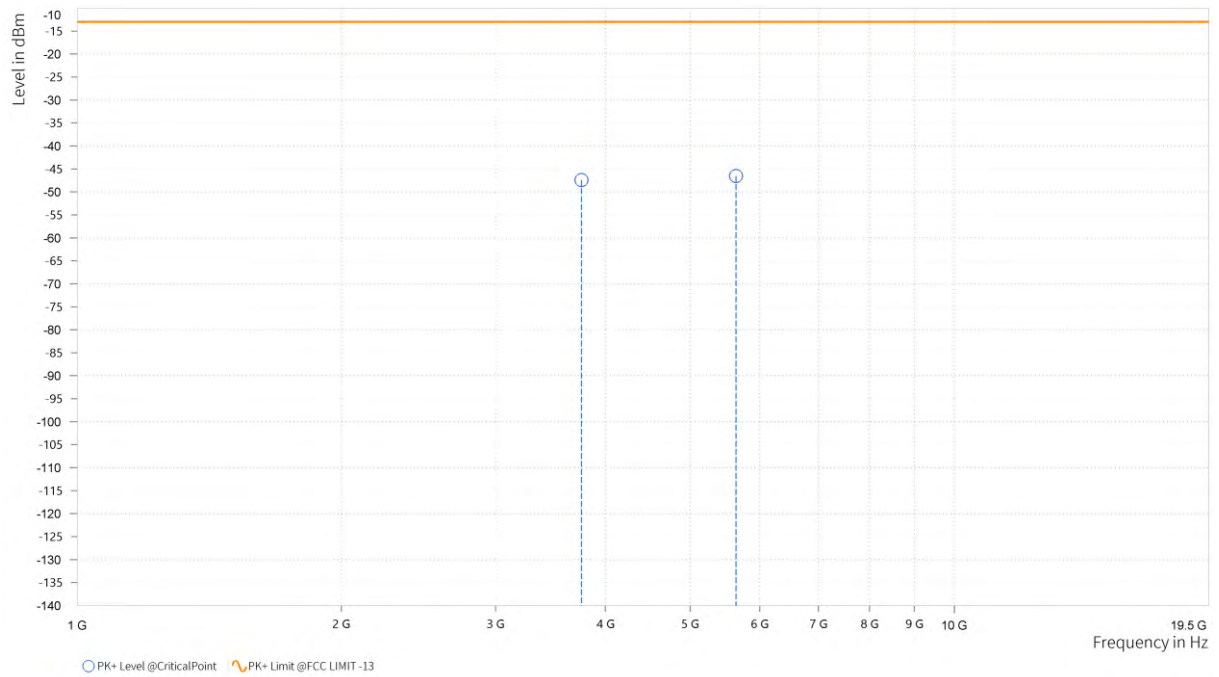



**BUREAU
VERITAS**

Test Report No.: PSU-QSU2312200110RF02

MODE	TX channel 18900	FREQUENCY RANGE	Above 1000MHz
ENVIRONMENTAL CONDITIONS	23deg. C, 70%RH	INPUT POWER	120Vac 60HZ
TESTED BY	Hanwen Xu		
ANTENNA POLARITY & TEST DISTANCE: VERTICAL AT 3 M			

Rg	Frequency [MHz]	PK+ Level [dBm]	PK+ Limit [dBm]	PK+ Margin [dB]	Correction [dB]	Polarization	Azimuth [deg]	Antenna Height [m]
4	3,758.540	-43.45	-13.00	30.45	25.45	V	162.1	2
4	5,638.110	-46.52	-13.00	33.52	26.73	V	359.1	1

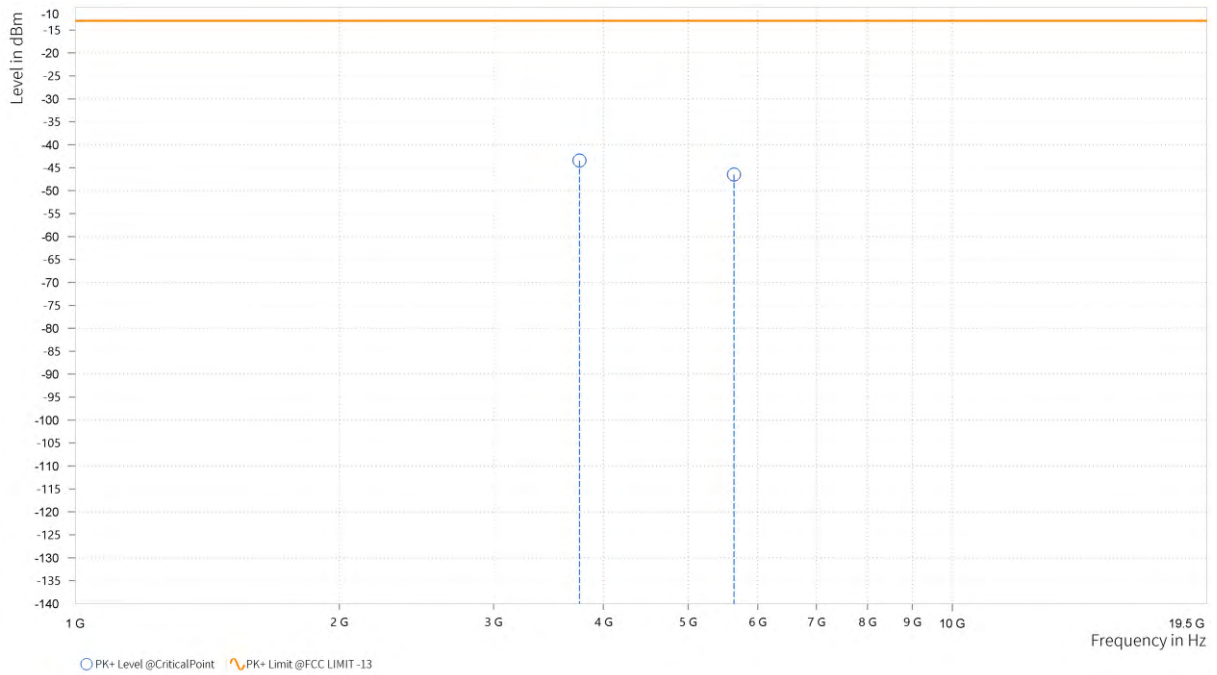



BUREAU VERITAS

Test Report No.: PSU-QSU2312200110RF02

CH19193

MODE	TX channel 19193	FREQUENCY RANGE	Above 1000MHz
ENVIRONMENTAL CONDITIONS	23deg. C, 70%RH	INPUT POWER	120Vac 60HZ
TESTED BY	Hanwen Xu		
ANTENNA POLARITY & TEST DISTANCE: HORIZONTAL AT 3 M			

Rg	Frequency [MHz]	PK+ Level [dBm]	PK+ Limit [dBm]	PK+ Margin [dB]	Correction [dB]	Polarization	Azimuth [deg]	Antenna Height [m]
4	3,798.740	-47.62	-13.00	34.62	25.77	H	359	2
4	5,698.110	-46.88	-13.00	33.88	26.94	H	1	2

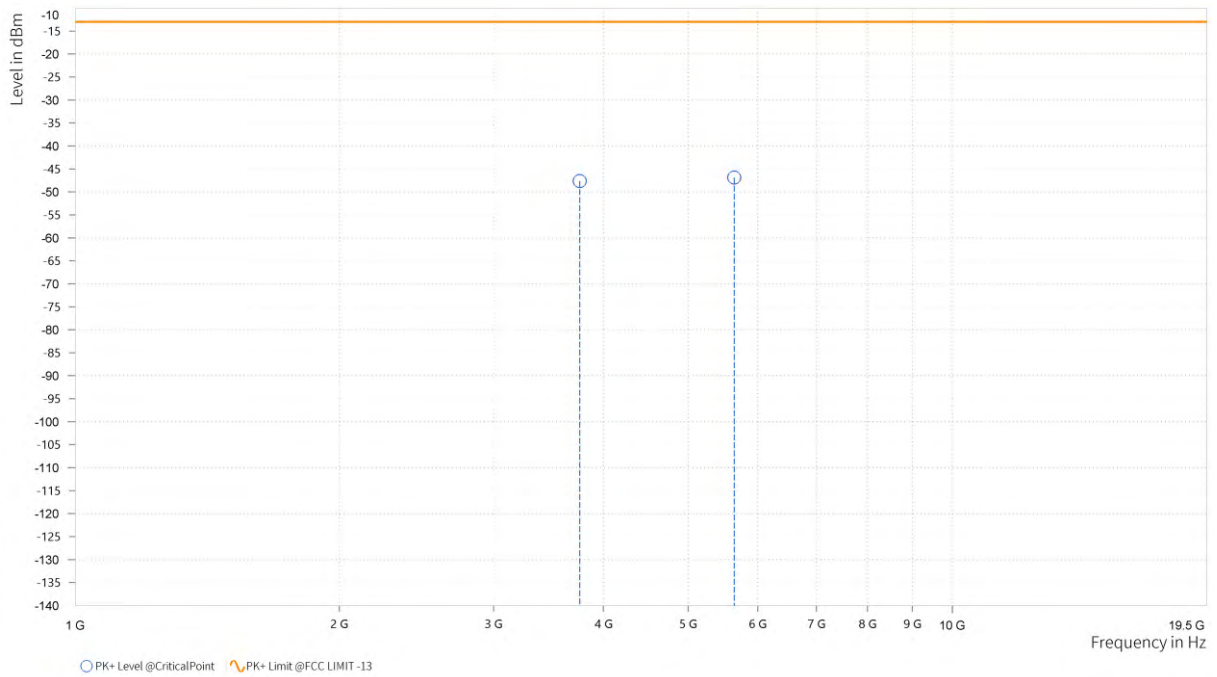



**BUREAU
VERITAS**

Test Report No.: PSU-QSU2312200110RF02

MODE	TX channel 19193	FREQUENCY RANGE	Above 1000MHz
ENVIRONMENTAL CONDITIONS	23deg. C, 70%RH	INPUT POWER	120Vac 60HZ
TESTED BY	Hanwen Xu		
ANTENNA POLARITY & TEST DISTANCE: VERTICAL AT 3 M			

Rg	Frequency [MHz]	PK+ Level [dBm]	PK+ Limit [dBm]	PK+ Margin [dB]	Correction [dB]	Polarization	Azimuth [deg]	Antenna Height [m]
4	3,798.740	-47.65	-13.00	34.65	25.46	V	162.1	2
4	5,698.110	-47.53	-13.00	34.53	26.68	V	217.1	1

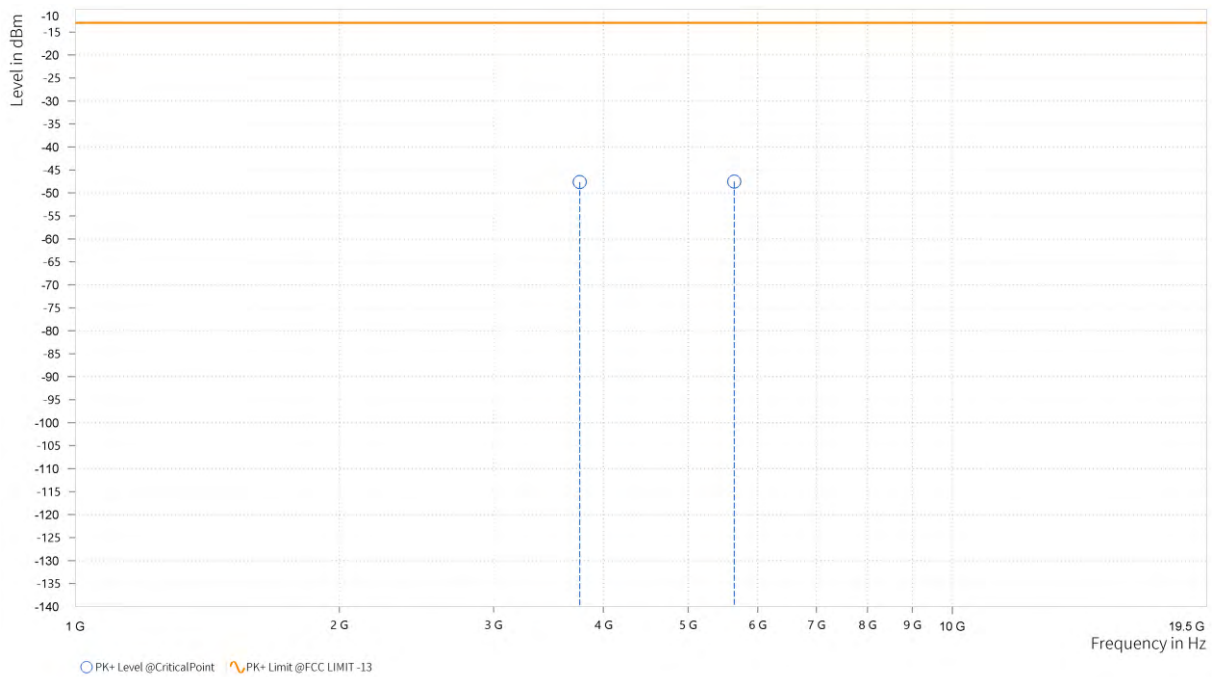



BUREAU VERITAS

Test Report No.: PSU-QSU2312200110RF02

CHANNEL BANDWIDTH: 3MHz / QPSK

MODE	TX channel 18900	FREQUENCY RANGE	Above 1000MHz
ENVIRONMENTAL CONDITIONS	23deg. C, 70%RH	INPUT POWER	120Vac 60HZ
TESTED BY	Hanwen Xu		
ANTENNA POLARITY & TEST DISTANCE: HORIZONTAL AT 3 M			

Rg	Frequency [MHz]	PK+ Level [dBm]	PK+ Limit [dBm]	PK+ Margin [dB]	Correction [dB]	Polarization	Azimuth [deg]	Antenna Height [m]
4	3,757.300	-46.35	-13.00	33.35	25.77	H	359.1	1
4	5,636.950	-46.80	-13.00	33.80	27.01	H	200.4	1

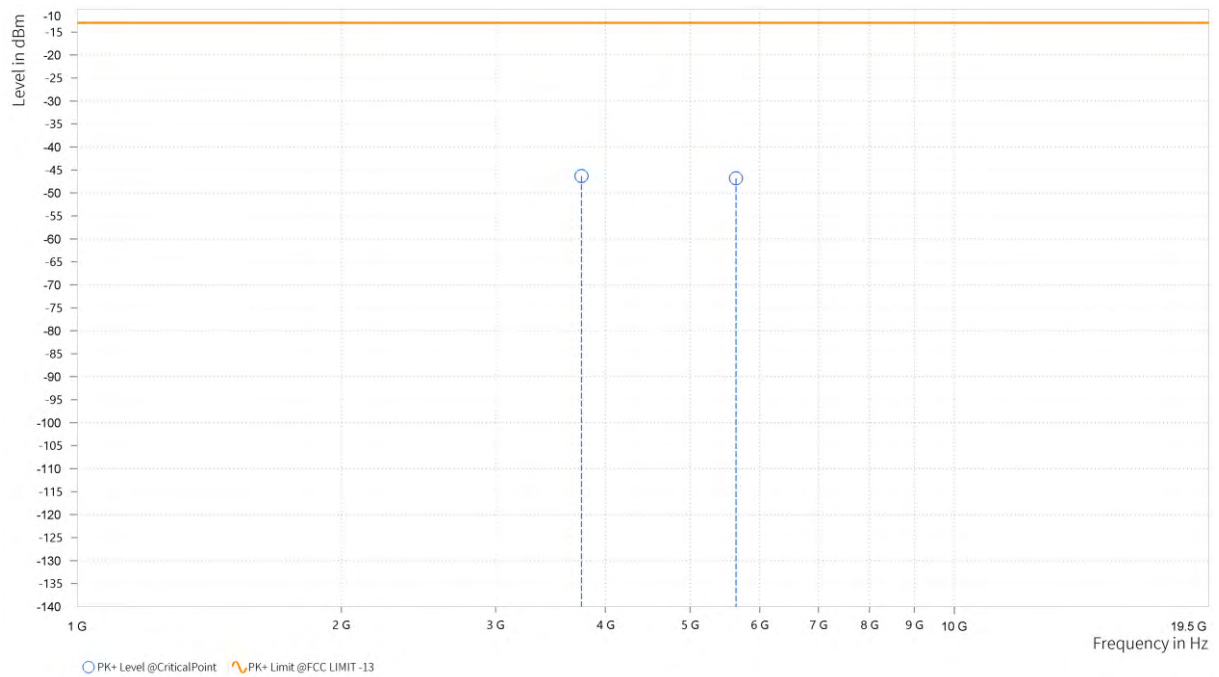



BUREAU VERITAS

Test Report No.: PSU-QSU2312200110RF02

MODE	TX channel 18900	FREQUENCY RANGE	Above 1000MHz
ENVIRONMENTAL CONDITIONS	23deg. C, 70%RH	INPUT POWER	120Vac 60HZ
TESTED BY	Hanwen Xu		
ANTENNA POLARITY & TEST DISTANCE: VERTICAL AT 3 M			

Rg	Frequency [MHz]	PK+ Level [dBm]	PK+ Limit [dBm]	PK+ Margin [dB]	Correction [dB]	Polarization	Azimuth [deg]	Antenna Height [m]
4	3,757.300	-46.72	-13.00	33.72	25.46	V	217.1	1
4	5,635.950	-47.26	-13.00	34.26	26.67	V	1	2

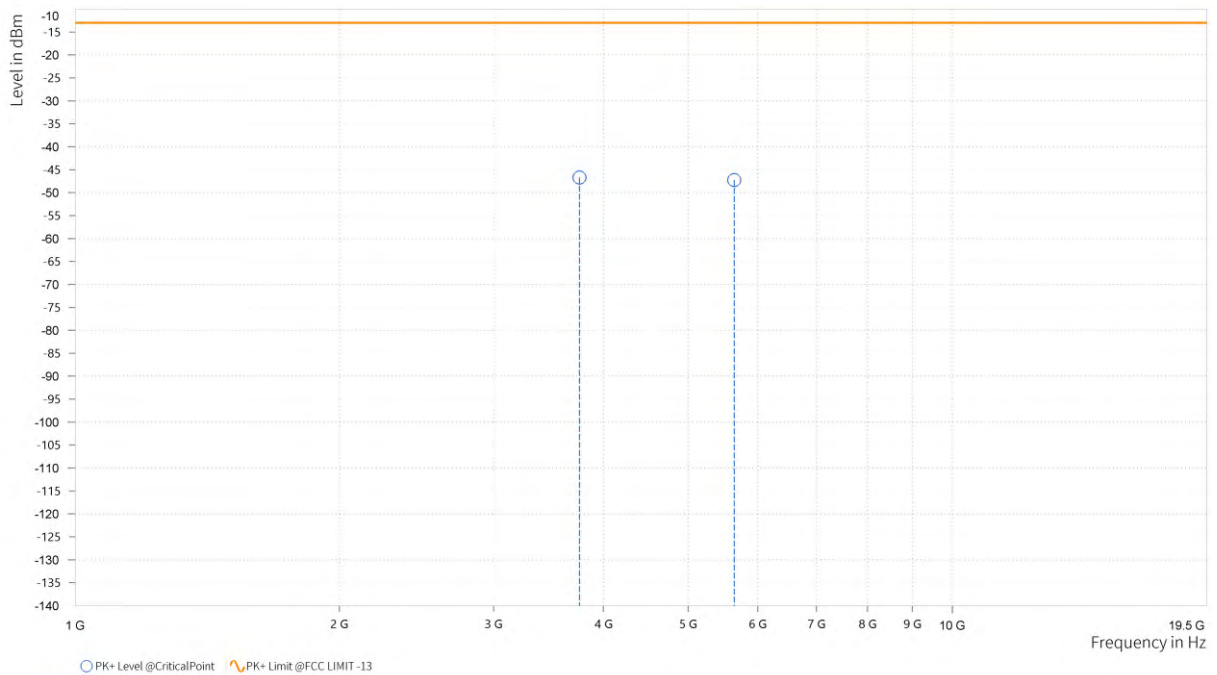



CHANNEL BANDWIDTH: 5MHz / QPSK

MODE	TX channel 18900	FREQUENCY RANGE	Above 1000MHz
ENVIRONMENTAL CONDITIONS	23deg. C, 70%RH	INPUT POWER	120Vac 60HZ
TESTED BY	Hanwen Xu		
ANTENNA POLARITY & TEST DISTANCE: HORIZONTAL AT 3 M			

Rg	Frequency [MHz]	PK+ Level [dBm]	PK+ Limit [dBm]	PK+ Margin [dB]	Correction [dB]	Polarization	Azimuth [deg]	Antenna Height [m]
4	3,755.500	-46.79	-13.00	33.79	25.77	H	158.6	2
4	5,633.250	-46.70	-13.00	33.70	27.07	H	359.1	1

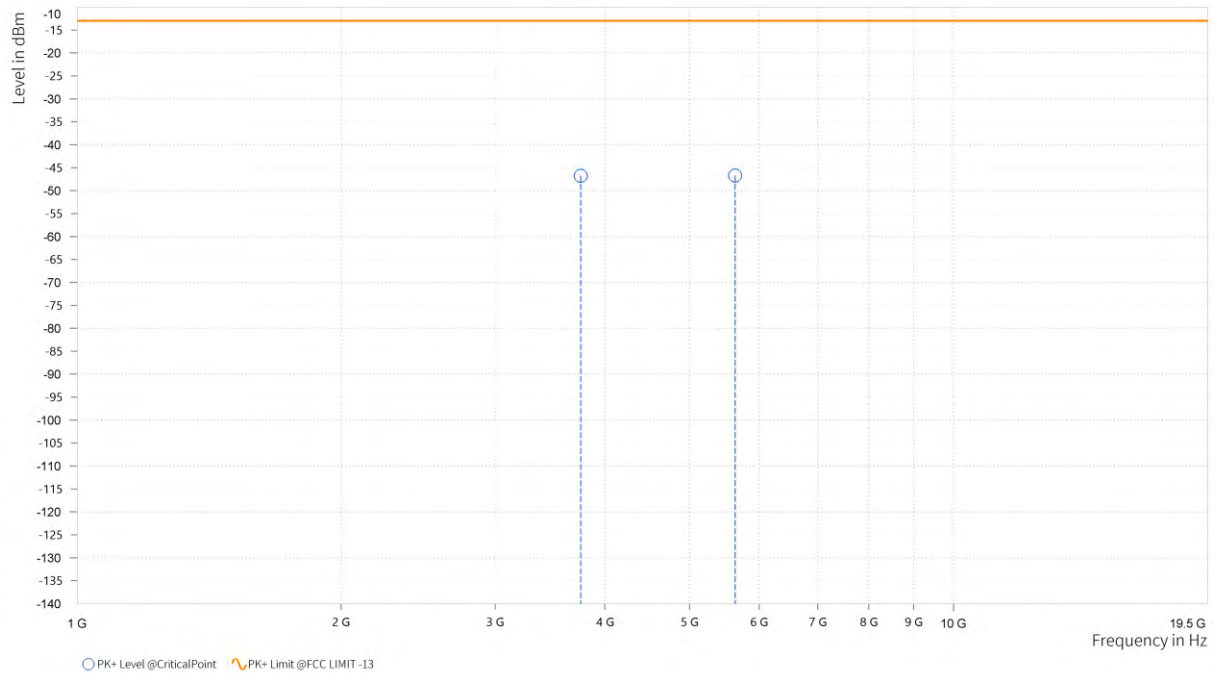



**BUREAU
VERITAS**

Test Report No.: PSU-QSU2312200110RF02

MODE	TX channel 18900	FREQUENCY RANGE	Above 1000MHz
ENVIRONMENTAL CONDITIONS	23deg. C, 70%RH	INPUT POWER	120Vac 60HZ
TESTED BY	Hanwen Xu		
ANTENNA POLARITY & TEST DISTANCE: VERTICAL AT 3 M			

Rg	Frequency [MHz]	PK+ Level [dBm]	PK+ Limit [dBm]	PK+ Margin [dB]	Correction [dB]	Polarization	Azimuth [deg]	Antenna Height [m]
4	3,755.500	-44.75	-13.00	31.75	25.45	V	152.6	2
4	5,633.250	-45.52	-13.00	32.52	26.79	V	202.8	1

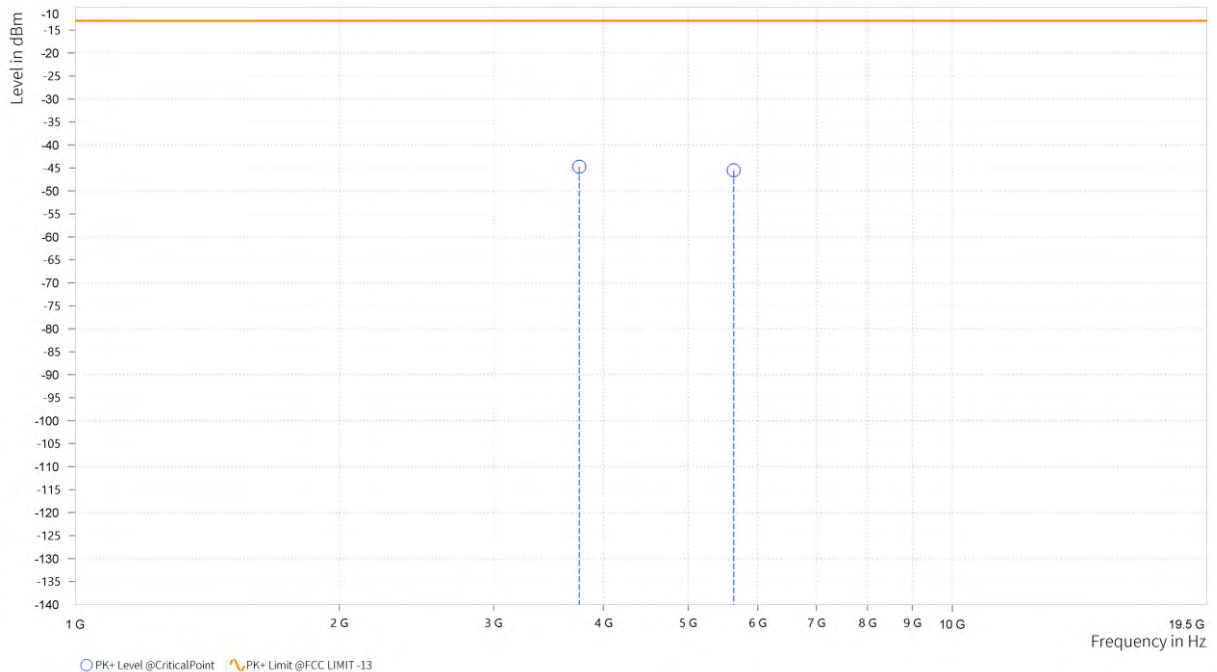



**BUREAU
VERITAS**

Test Report No.: PSU-QSU2312200110RF02

CHANNEL BANDWIDTH: 10MHz / QPSK

MODE	TX channel 18900	FREQUENCY RANGE	Above 1000MHz
ENVIRONMENTAL CONDITIONS	23deg. C, 70%RH	INPUT POWER	120Vac 60HZ
TESTED BY	Hanwen Xu		
ANTENNA POLARITY & TEST DISTANCE: HORIZONTAL AT 3 M			

Rg	Frequency [MHz]	PK+ Level [dBm]	PK+ Limit [dBm]	PK+ Margin [dB]	Correction [dB]	Polarization	Azimuth [deg]	Antenna Height [m]
4	3,751.000	-47.27	-13.00	34.27	25.47	V	1	1
4	5,626.500	-46.83	-13.00	33.83	26.94	V	162.1	2

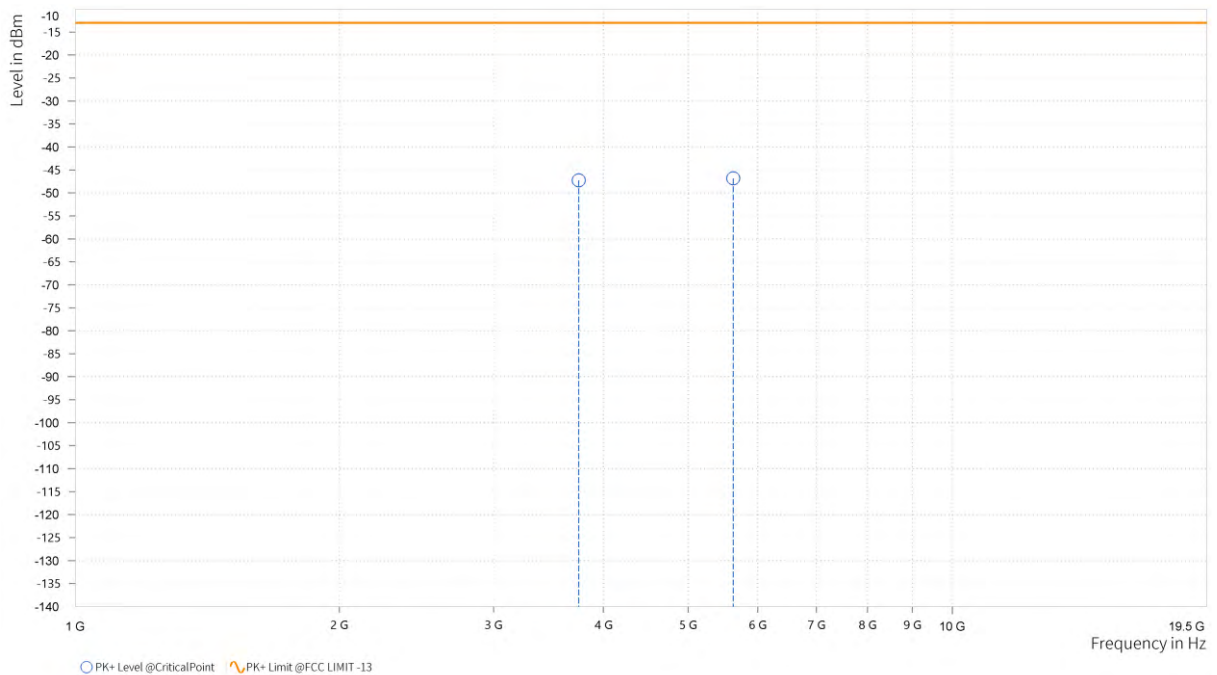



**BUREAU
VERITAS**

Test Report No.: PSU-QSU2312200110RF02

MODE	TX channel 18900	FREQUENCY RANGE	Above 1000MHz
ENVIRONMENTAL CONDITIONS	23deg. C, 70%RH	INPUT POWER	120Vac 60HZ
TESTED BY	Hanwen Xu		
ANTENNA POLARITY & TEST DISTANCE: VERTICAL AT 3 M			

Rg	Frequency [MHz]	PK+ Level [dBm]	PK+ Limit [dBm]	PK+ Margin [dB]	Correction [dB]	Polarization	Azimuth [deg]	Antenna Height [m]
4	3,751.000	-47.63	-13.00	34.63	25.76	H	359	1
4	5,626.500	-45.99	-13.00	32.99	27.17	H	0.9	2

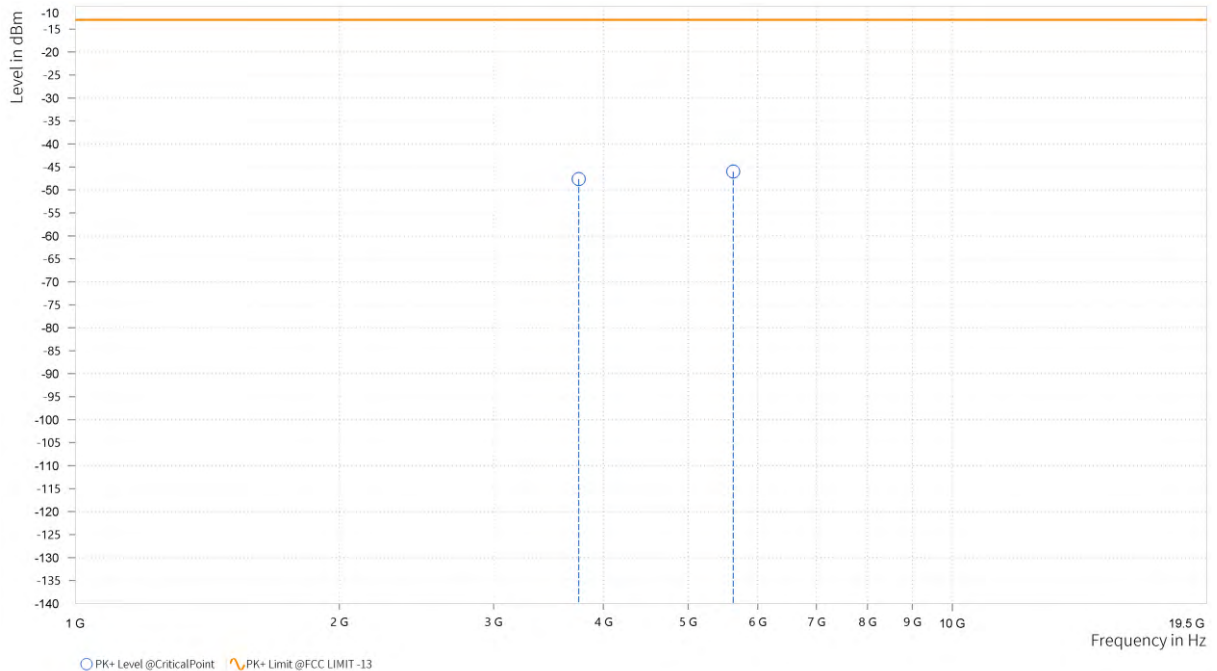



CHANNEL BANDWIDTH: 15MHz / QPSK

MODE	TX channel 18900	FREQUENCY RANGE	Above 1000MHz
ENVIRONMENTAL CONDITIONS	23deg. C, 70%RH	INPUT POWER	120Vac 60HZ
TESTED BY	Hanwen Xu		
ANTENNA POLARITY & TEST DISTANCE: HORIZONTAL AT 3 M			

Rg	Frequency [MHz]	PK+ Level [dBm]	PK+ Limit [dBm]	PK+ Margin [dB]	Correction [dB]	Polarization	Azimuth [deg]	Antenna Height [m]
4	3,746.500	-45.28	-13.00	32.28	25.76	H	160.9	2
4	5,619.750	-47.05	-13.00	34.05	27.27	H	196.8	1

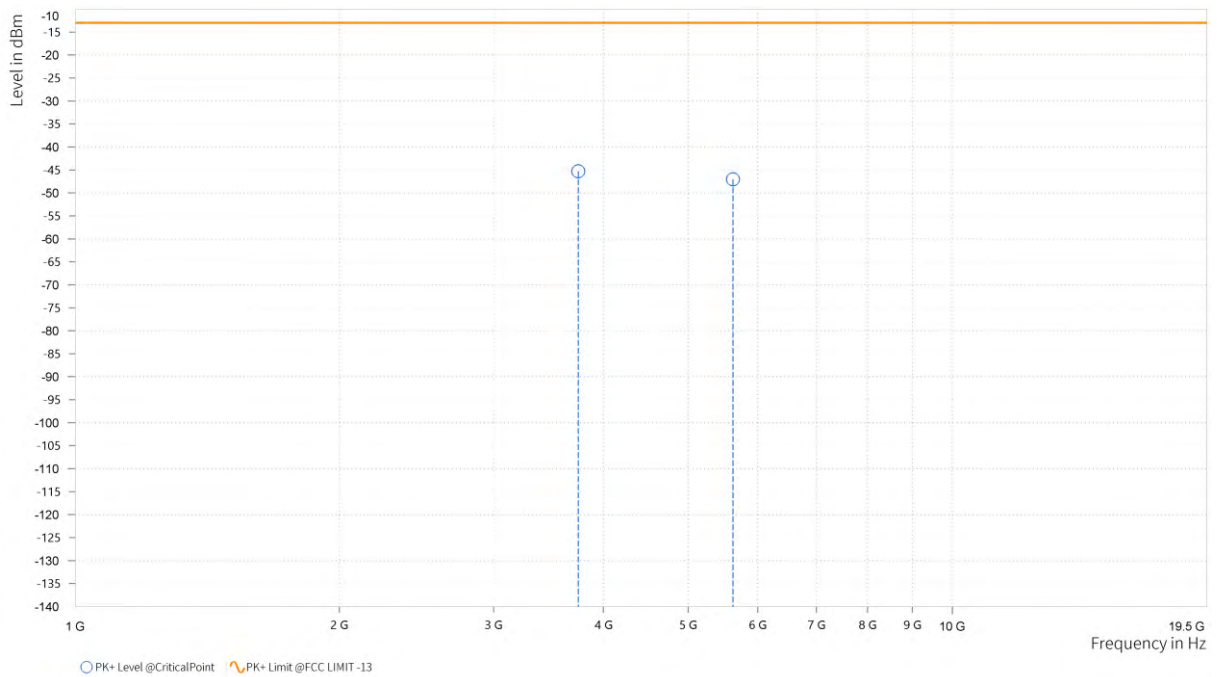



BUREAU VERITAS

Test Report No.: PSU-QSU2312200110RF02

MODE	TX channel 18900	FREQUENCY RANGE	Above 1000MHz
ENVIRONMENTAL CONDITIONS	23deg. C, 70%RH	INPUT POWER	120Vac 60HZ
TESTED BY	Hanwen Xu		
ANTENNA POLARITY & TEST DISTANCE: VERTICAL AT 3 M			

Rg	Frequency [MHz]	PK+ Level [dBm]	PK+ Limit [dBm]	PK+ Margin [dB]	Correction [dB]	Polarization	Azimuth [deg]	Antenna Height [m]
4	3,746.500	-47.84	-13.00	34.84	25.47	V	359	2
4	5,619.750	-46.60	-13.00	33.60	27.07	V	0.9	2

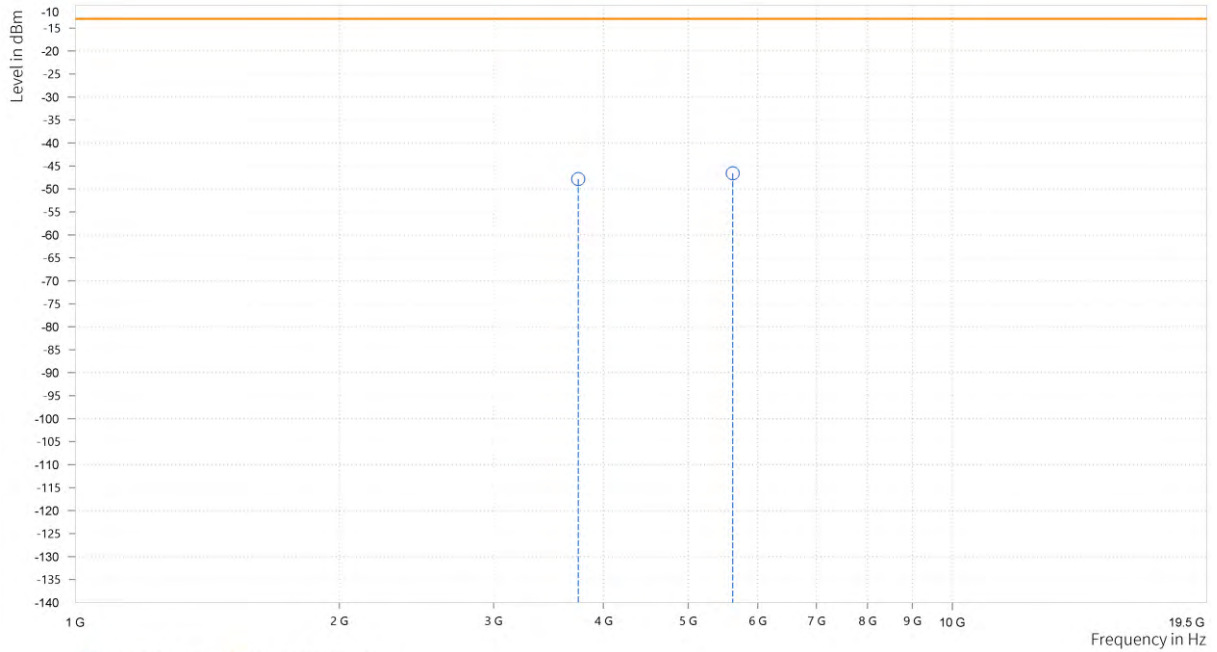



CHANNEL BANDWIDTH: 20MHz / QPSK

MODE	TX channel 18900	FREQUENCY RANGE	Above 1000MHz
ENVIRONMENTAL CONDITIONS	23deg. C, 70%RH	INPUT POWER	120Vac 60HZ
TESTED BY	Hanwen Xu		
ANTENNA POLARITY & TEST DISTANCE: HORIZONTAL AT 3 M			

Rg	Frequency [MHz]	PK+ Level [dBm]	PK+ Limit [dBm]	PK+ Margin [dB]	Correction [dB]	Polarization	Azimuth [deg]	Antenna Height [m]
4	3,742.000	-47.05	-13.00	34.05	25.77	H	359	2
4	5,613.000	-47.18	-13.00	34.18	26.93	H	359.1	1

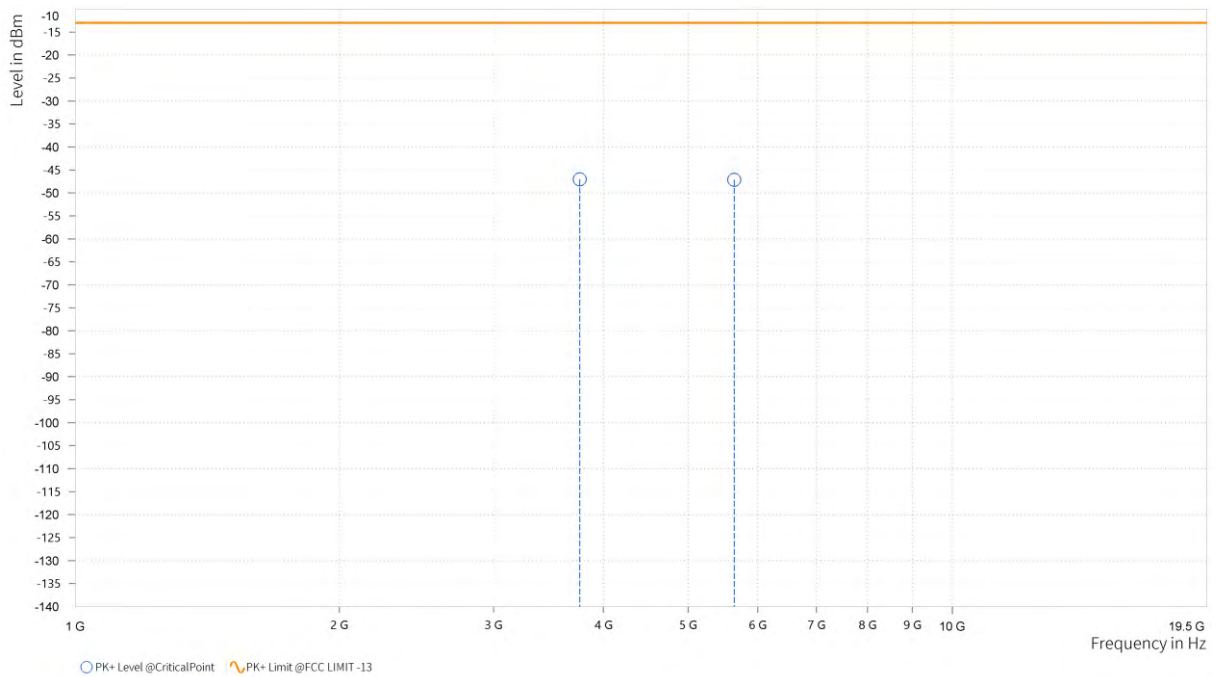



**BUREAU
VERITAS**

Test Report No.: PSU-QSU2312200110RF02

MODE	TX channel 18900	FREQUENCY RANGE	Above 1000MHz
ENVIRONMENTAL CONDITIONS	23deg. C, 70%RH	INPUT POWER	120Vac 60HZ
TESTED BY	Hanwen Xu		
ANTENNA POLARITY & TEST DISTANCE: VERTICAL AT 3 M			

Rg	Frequency [MHz]	PK+ Level [dBm]	PK+ Limit [dBm]	PK+ Margin [dB]	Correction [dB]	Polarization	Azimuth [deg]	Antenna Height [m]
4	3,742.000	-47.65	-13.00	34.65	25.45	V	1	1
4	5,613.000	-47.62	-13.00	34.62	26.63	V	117.8	2

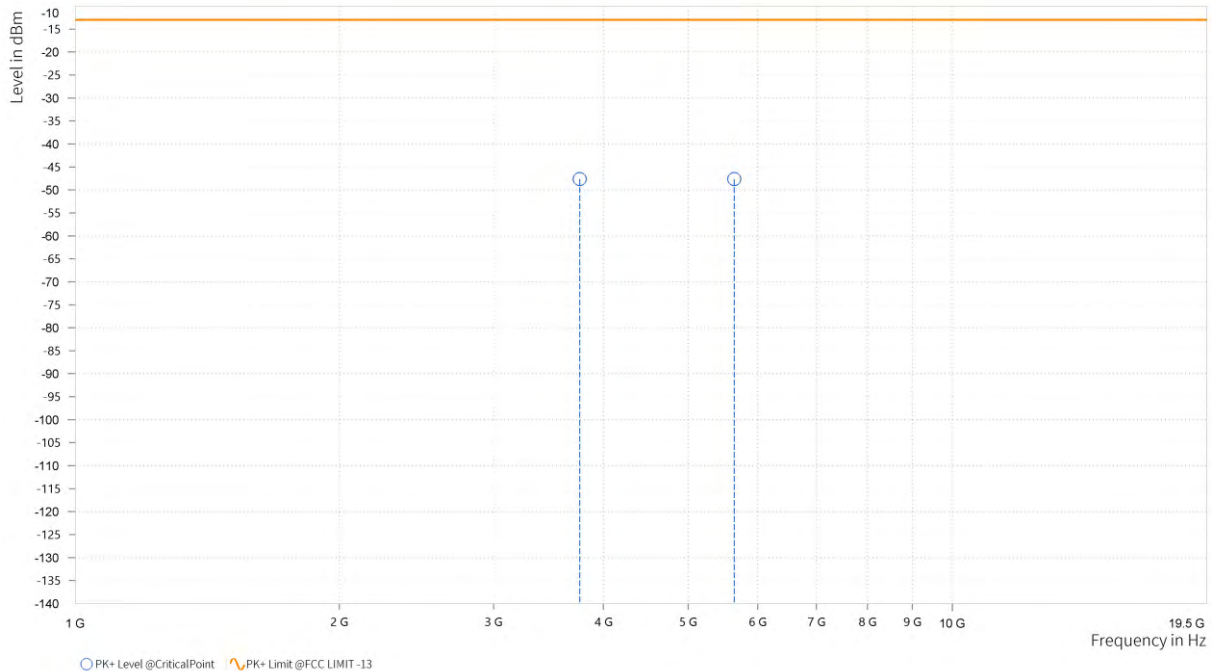



3.7 PEAK TO AVERAGE RATIO

3.7.1 LIMITS OF PEAK TO AVERAGE RATIO MEASUREMENT

In measuring transmissions in this band using an average power technique, the peak to-average ratio (PAR) of the transmission may not exceed 13 dB

3.7.2 TEST SETUP

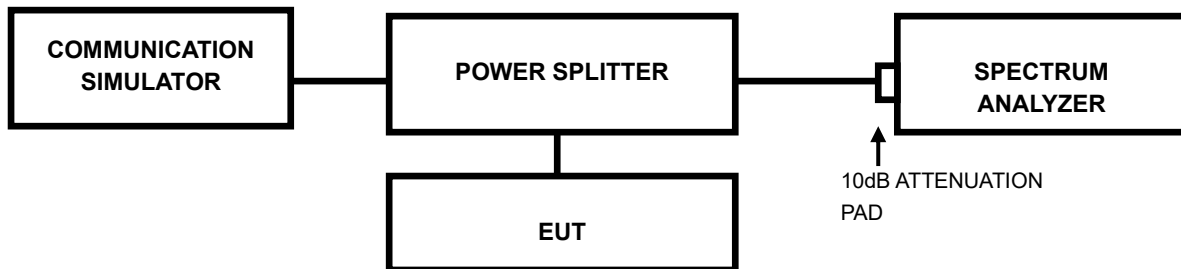

3.7.3 TEST PROCEDURES

1. Set resolution/measurement bandwidth \geq signal's occupied bandwidth;
2. Set the number of counts to a value that stabilizes the measured CCDF curve;
3. Record the maximum PAPR level associated with a probability of 0.1%.



Test Report No.: PSU-QSU2312200110RF02

3.7.4 TEST RESULTS

Please Refer to Appendix Of this test report.



Test Report No.: PSU-QSU2312200110RF02

4 INFORMATION ON THE TESTING LABORATORIES

We, Huarui 7layers High Technology (Suzhou) Co., Ltd. ,were founded in 2020 to provide our best service in EMC, Radio, Telecom and Safety consultation. Our laboratories are accredited and approved according to ISO/IEC 17025.

If you have any comments, please feel free to contact us at the following:

Suzhou EMC/RF Lab:

Tel: +86 (0557) 368 1008



Test Report No.: PSU-QSU2312200110RF02

5 MODIFICATIONS RECORDERS FOR ENGINEERING CHANGES TO THE EUT BY THE LAB

No any modifications are made to the EUT by the lab during the test.



6 Appendix

GSM 1900

PEAK-TO-AVERAGE RATIO(CCDF)

Test Result

Band	Channel	Result(dB)	Limit(dB)	Verdict
GSM1900	512	2.84	13	PASS
GSM1900	661	2.87	13	PASS
GSM1900	810	2.89	13	PASS
EGPRS1900	512	3.03	13	PASS
EGPRS1900	661	3.05	13	PASS
EGPRS1900	810	3.05	13	PASS



BUREAU VERITAS

Test Report No.: PSU-QSU2312200110RF02



EGPRS1900-512

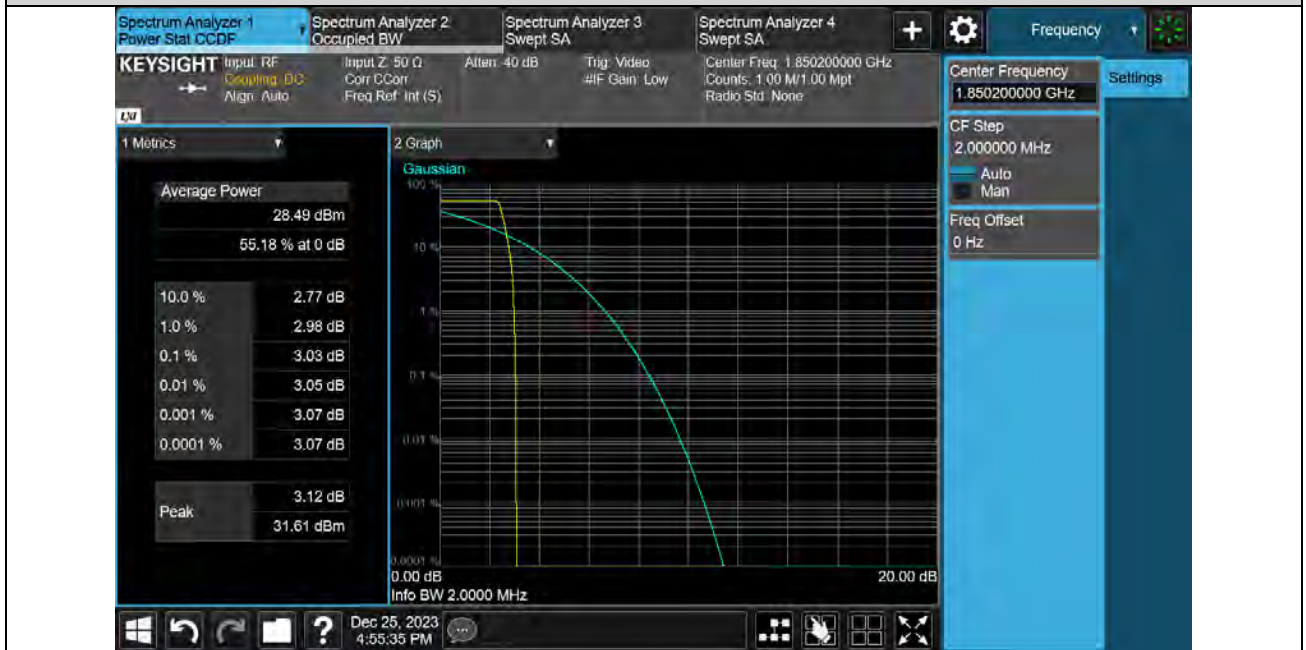

EGPRS1900-661



BUREAU VERITAS

Test Report No.: PSU-QSU2312200110RF02

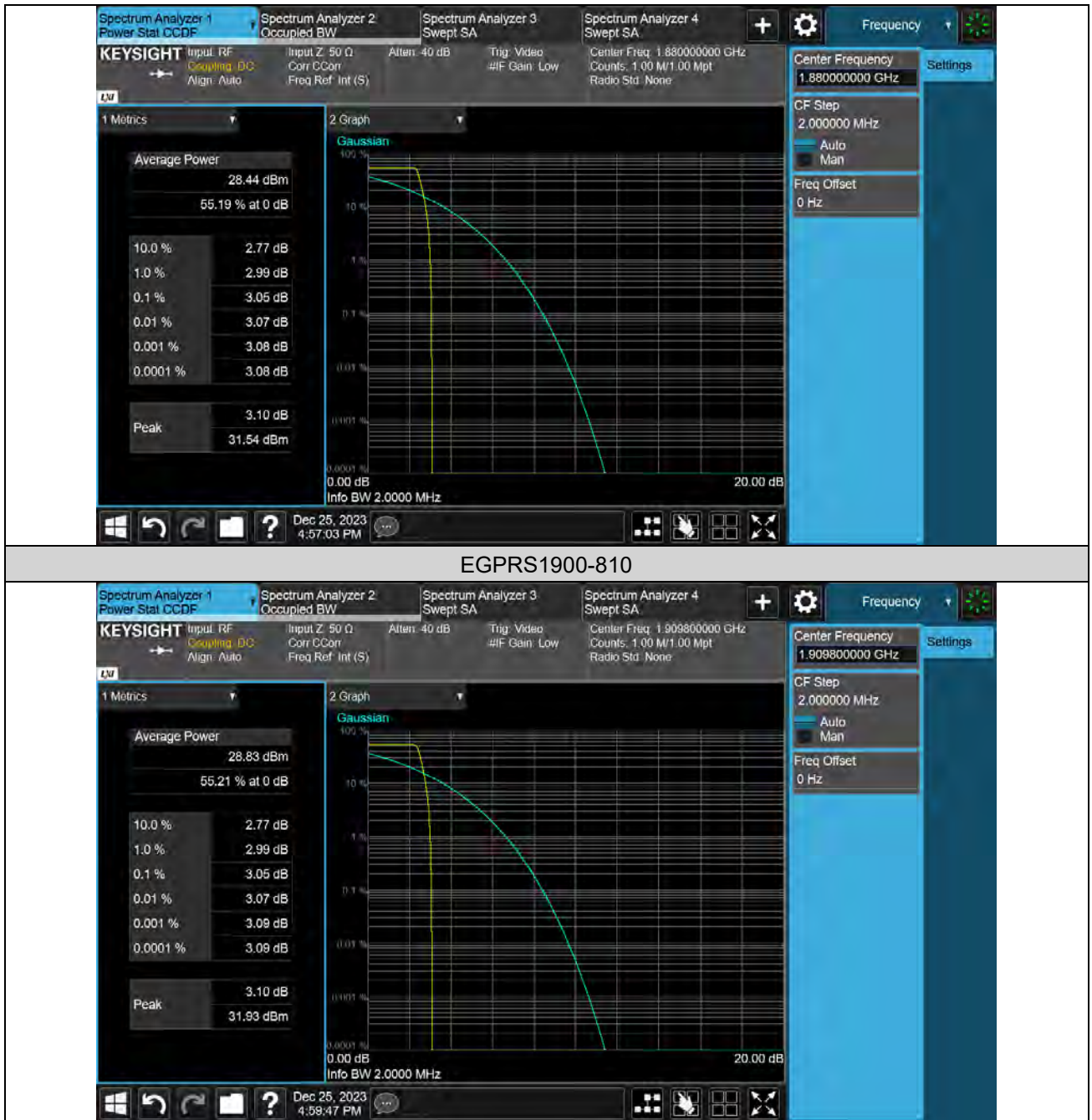



26DB BANDWIDTH AND OCCUPIED BANDWIDTH

Test Result

Band	Channel	Occupied Bandwidth (MHz)	26dB Bandwidth (MHz)	Limit (MHz)	Verdict
GSM1900	512	See graph	See graph	---	PASS
GSM1900	661	See graph	See graph	---	PASS
GSM1900	810	See graph	See graph	---	PASS
EGPRS1900	512	See graph	See graph	---	PASS
EGPRS1900	661	See graph	See graph	---	PASS
EGPRS1900	810	See graph	See graph	---	PASS



BUREAU VERITAS

Test Report No.: PSU-QSU2312200110RF02

Test Graphs

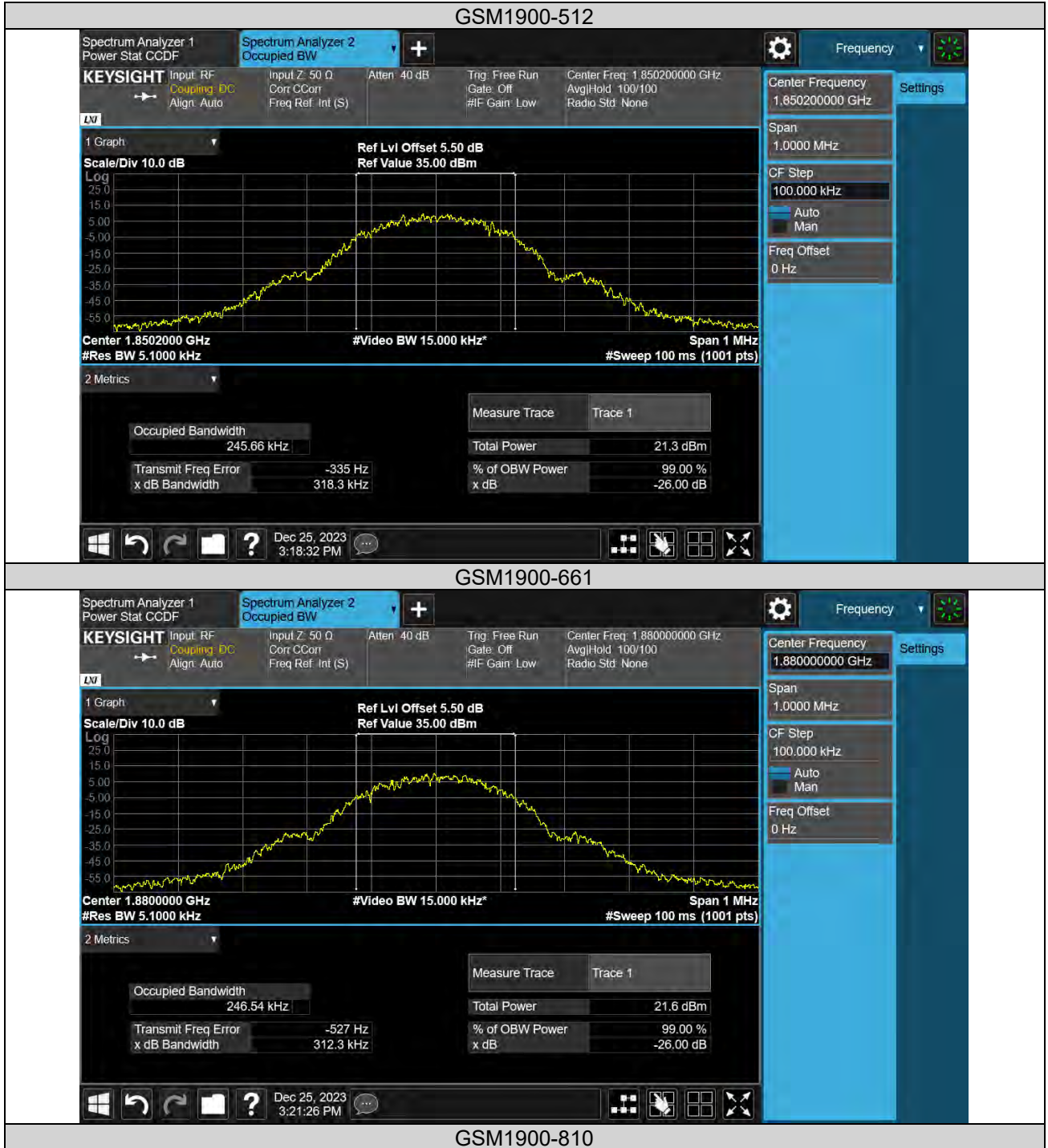



BUREAU VERITAS

Test Report No.: PSU-QSU2312200110RF02





EGPRS1900-810





BAND EDGE

Test Result

Band	Channel	Freq (MHz)	Result (dBm)	Limit(dBm)	Verdict
GSM1900	512	See graph	See graph	-13	PASS
GSM1900	810	See graph	See graph	-13	PASS
EGPRS1900	512	See graph	See graph	-13	PASS
EGPRS1900	810	See graph	See graph	-13	PASS



BUREAU
VERITAS

Test Report No.: PSU-QSU2312200110RF02

Test Graphs

