



BUREAU VERITAS

Test Report No.: PSU-NQN2406210109RF01



Certificate #6613.01

FCC TEST REPORT (PART 22)



Applicant:	Power Idea Technology (Shenzhen) Co., Ltd.
Address:	4th Floor, A Section, Languang Science&technology Building, No.7 Xinxi RD, Hi-Tech Industrial Park North, Nanshan District, ShenZhen, P.R.C.

Manufacturer or Supplier:	Power Idea Technology (Shenzhen) Co., Ltd.
Address:	4th Floor, A Section, Languang Science&technology Building, No.7 Xinxi RD, Hi-Tech Industrial Park North, Nanshan District, ShenZhen, P.R.C.
Product:	Smart Phone
Brand Name:	RugGear
Model Name:	PSM05G
Marketing name:	RG880i
FCC ID:	ZLE-PSM05G
Date of tests:	Aug. 28, 2024 ~ Sep.27, 2024

The tests have been carried out according to the requirements of the following standard:

- FCC PART 22, Subpart H
- ANS/TIA/EIA-603-D
- ANS/TIA/EIA-603-E
- FCC Part 2
- ANSI C63.26-2015

CONCLUSION: The submitted sample was found to COMPLY with the test requirement

Prepared by Hanwen Xu Engineer / Mobile Department	Approved by Peibo Sun Manager / Mobile Department
 Date: Sep.27, 2024	 Date: Sep.27, 2024

This report is governed by, and incorporates by reference, the Conditions of Testing as posted at the date of issuance of this report at <http://www.bureauveritas.com/home/about-us/our-business/cps/about-us/terms-conditions/> and is intended for your exclusive use. Any copying or replication of this report to or for any other person or entity, or use of our name or trademark, is permitted only with our prior written permission. This report sets forth our findings solely with respect to the test samples identified herein. The results set forth in this report are not indicative or representative of the quality or characteristics of the lot from which a test sample was taken or any similar or identical product unless specifically and expressly noted. Our report includes all of the tests requested by you and the results thereof based upon the information that you provided to us. Measurement uncertainty is only provided upon request for accredited tests. Statements of conformity are based on simple acceptance criteria without taking measurement uncertainty into account, unless otherwise requested in writing. You have 60 days from date of issuance of this report to notify us of any material error or omission caused by our negligence or if you require measurement uncertainty; provided, however, that such notice shall be in writing and shall specifically address the issue you wish to raise. A failure to raise such issue within the prescribed time shall constitute your unqualified acceptance of the completeness of this report, the tests conducted and the correctness of the report contents.



TABLE OF CONTENTS

RELEASE CONTROL RECORD	5
1 SUMMARY OF TEST RESULTS	6
1.1 MEASUREMENT UNCERTAINTY	7
1.2 TEST SITE AND INSTRUMENTS	8
2 GENERAL INFORMATION	11
2.1 GENERAL DESCRIPTION OF EUT	11
2.2 CONFIGURATION OF SYSTEM UNDER TEST	14
2.3 DESCRIPTION OF SUPPORT UNITS	15
2.4 TEST ITEM AND TEST CONFIGURATION	15
2.5 EUT OPERATING CONDITIONS	19
2.6 GENERAL DESCRIPTION OF APPLIED STANDARDS	20
3 TEST TYPES AND RESULTS	21
3.1 OUTPUT POWER MEASUREMENT	21
3.1.1 LIMITS OF OUTPUT POWER MEASUREMENT	21
3.1.2 TEST PROCEDURES	21
3.1.3 TEST SETUP	22
3.1.4 TEST RESULTS	22
3.2 FREQUENCY STABILITY MEASUREMENT	33
3.2.1 LIMITS OF FREQUENCY STABILITY MEASUREMENT	33
3.2.2 TEST PROCEDURE	33
3.2.3 TEST SETUP	33
3.2.4 TEST RESULTS	34
3.3 OCCUPIED BANDWIDTH MEASUREMENT	35
3.3.1 LIMITS OF OCCUPIED BANDWIDTH MEASUREMENT	35
3.3.2 TEST SETUP	35
3.3.3 TEST PROCEDURES	35
3.3.4 TEST RESULTS	36
3.4 BAND EDGE MEASUREMENT	37
3.4.1 LIMITS OF BAND EDGE MEASUREMENT	37
3.4.2 TEST SETUP	37
3.4.3 TEST PROCEDURES	38
3.4.4 TEST RESULTS	39
3.5 CONDUCTED SPURIOUS EMISSIONS	40
3.5.1 LIMITS OF CONDUCTED SPURIOUS EMISSIONS MEASUREMENT	40
3.5.2 TEST PROCEDURE	40
3.5.3 TEST SETUP	40
3.5.4 TEST RESULTS	41
3.6 RADIATED EMISSION MEASUREMENT	42
3.6.1 LIMITS OF RADIATED EMISSION MEASUREMENT	42
3.6.2 TEST PROCEDURES	42
3.6.3 DEVIATION FROM TEST STANDARD	42
3.6.4 TEST SETUP	43
3.6.5 TEST RESULTS	45



3.7 PEAK TO AVERAGE RATIO 83

 3.7.1 LIMITS OF PEAK TO AVERAGE RATIO MEASUREMENT 83

 3.7.2 TEST SETUP 83

 3.7.3 TEST PROCEDURES 83

 3.7.4 TEST RESULTS 84

4 PHOTOGRAPHS OF THE TEST CONFIGURATION 85

5 INFORMATION ON THE TESTING LABORATORIES 86

6 MODIFICATIONS RECORDERS FOR ENGINEERING CHANGES TO THE EUT BY THE LAB 87

7 APPENDIX: 88

 GSM850 88

 PEAK-TO-AVERAGE RATIO(CCDF) 88

 TEST RESULT 88

 TEST GRAPHS 89

 26DB BANDWIDTH AND OCCUPIED BANDWIDTH 92

 TEST RESULT 92

 TEST GRAPHS 93

 BAND EDGE 99

 TEST RESULT 99

 TEST GRAPHS 100

 CONDUCTED SPURIOUS EMISSION 102

 TEST RESULT 102

 TEST GRAPHS 103

 FREQUENCY STABILITY 106

 TEST RESULT 106

 CDMA2000 BC0 108

 PEAK-TO-AVERAGE RATIO(CCDF) 108

 TEST RESULT 108

 TEST GRAPHS 109

 26DB BANDWIDTH AND OCCUPIED BANDWIDTH 110

 TEST RESULT 110

 TEST GRAPHS 111

 BAND EDGE 112

 TEST RESULT 112

 TEST GRAPHS 113

 CONDUCTED SPURIOUS EMISSION 114

 TEST RESULT 114

 TEST GRAPHS 115

 FREQUENCY STABILITY 116

 TEST RESULT 116

 WCMDA BAND5 118

 PEAK-TO-AVERAGE RATIO 118

 TEST RESULT 118

 TEST GRAPHS 119

 26DB BANDWIDTH AND OCCUPIED BANDWIDTH 121

 TEST RESULT 121



TEST GRAPHS	122
BAND EDGE	125
TEST RESULT	125
TEST GRAPHS	126
CONDUCTED SPURIOUS EMISSION	127
TEST RESULT	127
TEST GRAPHS	128
FREQUENCY STABILITY	130
TEST RESULT	130
LTE BAND5	132
PEAK-TO-AVERAGE RATIO(CCDF)	132
TEST RESULT	132
TEST GRAPHS	134
26DB BANDWIDTH AND OCCUPIED BANDWIDTH	144
TEST RESULT	144
TEST GRAPHS	145
BAND EDGE	155
TEST RESULT	155
TEST GRAPHS	157
CONDUCTED SPURIOUS EMISSION	163
TEST RESULT	163
TEST GRAPHS	164
FREQUENCY STABILITY	170
TEST RESULT	170



BUREAU
VERITAS

Test Report No.: PSU-NQN2406210109RF01

RELEASE CONTROL RECORD

ISSUE NO.	REASON FOR CHANGE	DATE ISSUED
PSU-NQN2406210109RF01	Original release	Sep.27, 2024



1 SUMMARY OF TEST RESULTS

The EUT has been tested according to the following specifications:

APPLIED STANDARD: FCC Part 22 & Part 2			
STANDARD SECTION	TEST TYPE	RESULT	Test lab*
§2.1046	Conducted Output Power	Compliance	A
§22.913 (a)(5) §22.913(a)(2)	Effective Radiated Power	Compliance	A
§2.1055 §22.355	Frequency Stability	Compliance	A/B
§2.1049 §22.917(b)	Occupied Bandwidth	Compliance	A/B
§22.913 (d)	Peak to average ratio*	Compliance	A/B
§22.917(a)	Band Edge Measurements	Compliance	A/B
§2.1051 §22.917(a)	Conducted Spurious Emissions	Compliance	A/B
§2.1053 §22.917(a)	Radiated Spurious Emissions	Compliance	A/B

* Refer to KDB 971168 D01 Power Meas License Digital Systems v03r01.

NOTE: The maximum RF output power level is 1xRTT RC3 SO55 mode for CDMA2000 BC0, so only 1xRTT mode was used for all tests.

*Test Lab Information Reference

Lab A:

Huarui 7Layers High Technology (Suzhou) Co., Ltd.

Lab Address:

Tower N, Innovation Center, 88 Zuyi Road, High-tech District, Suzhou City, Anhui Province

Accredited Test Lab Cert 6613.01

The FCC Site Registration No. is 434559; The Designation No. is CN1325.

Lab B:

BV 7Layers Communications Technology (Shenzhen) Co. Ltd

Lab Address:

Room B37, Warehouse A5, No.3 Chiwan 4th Road, Zhaoshang Street, Nanshan District
Shenzhen, Guangdong, People's Republic of China

Accredited Test Lab Cert 3939.01

The FCC Site Registration No. is 525120; The Designation No. is CN1171.



1.1 MEASUREMENT UNCERTAINTY

Where relevant, the following measurement uncertainty levels have been estimated for tests performed on the EUT as specified in CISPR 16-4-2:

MEASUREMENT	UNCERTAINTY
Maximum Peak Output Power	±2.06dB
Frequency Stability	±76.97Hz
Radiated emissions (9KHz~30MHz)	±2.68dB
Radiated emissions (30MHz~1GHz)	±4.98dB
Radiated emissions (1GHz ~6GHz)	±4.70dB
Radiated emissions (6GHz ~18GHz)	±4.60dB
Radiated emissions (18GHz ~40GHz)	±4.12dB
Conducted emissions	±4.01dB
Occupied Channel Bandwidth	±43.58KHz
Band Edge Measurements	±4.70dB
Peak to average ratio	±0.76dB

This uncertainty represents an expanded uncertainty expressed at approximately the 95% confidence level using a coverage factor of k=2.

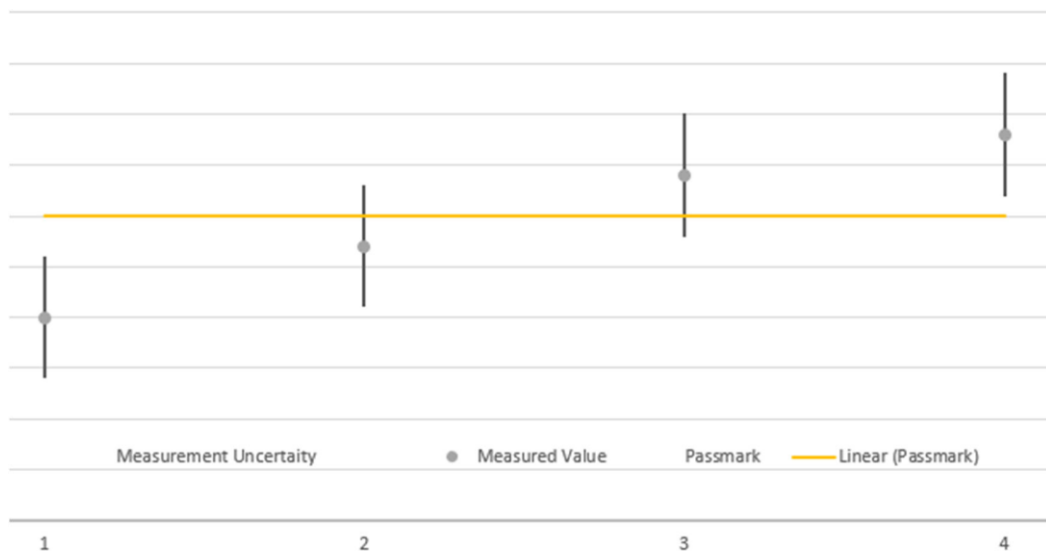

The verdicts in this test report are given according the above diagram:

Case	Measured Value	Uncertainty Range	Verdict
1	below pass mark	below pass mark	Passed
2	below pass mark	within pass mark	Passed
3	above pass mark	within pass mark	Failed
4	above pass mark	above pass mark	Failed

That means, the laboratory applies, as decision rule (see ISO/IEC 17025:2017), the so-called shared risk principle.

**1.2 TEST SITE AND INSTRUMENTS**

Lab A:

Equipment	Manufacturer	Model No.	Serial No.	Last Cal.	Next Cal.
Pre-Amplifier	R&S	SCU18F1	100815	Aug.30,22	Aug.29,24
Pre-Amplifier	R&S	SCU18F1	100815	Aug.29,24	Aug.28,26
Pre-Amplifier	R&S	SCU08F1	101028	Sep.16,22	Sep.15,24
Pre-Amplifier	R&S	SCU08F1	101028	Sep.15,24	Sep.14,26
Vector Signal Generator	R&S	SMBV100B	102176	Mar.29,24	Mar.28,26
Signal Generator	R&S	SMB100A	182185	Mar.29,24	Mar.28,26
3m Fully-anechoic Chamber	TDK	9m*6m*6m	HRSW-SZ-E MC-01 Chamber	Nov.25,22	Nov.24,25
3m Semi-anechoic Chamber	TDK	9m*6m*6m	HRSW-SZ-E MC-02 Chamber	Nov.25,22	Nov.24,25
EMI TEST Receiver	R&S	ESR26	101734	Mar.28,24	Mar.27,26
EMI TEST Receiver	R&S	ESW44	101973	Mar.28,24	Mar.27,26
Bilog Antenna	SCHWARZBECK	VULB 9163	1264	Dec.26,23	Dec.25,25
Horn Antenna	ETS-LINDGREN	3117	227836	Aug.21,24	Aug.20,26
Horn Antenna (18GHz-40GHz)	Steatite Q-par Antennas	QMS 00880	23486	Jul.15,24	Jul.14,26
Horn Antenna	Steatite Q-par Antennas	QMS 00208	23485	Aug.21,24	Aug.20,26
Loop Antenna	SCHWARZ	HFH2-Z2/Z2E	100976	Feb.22,24	Feb.21,26
WIDEBANDRADIO COMMUNICATION TESTER	R&S	CMW500	169399	Jun.19,24	Jun.18,26
Test Software	EMC32	EMC32	N/A	N/A	N/A
6DB attenuator	Tonscend Technology Co., Ltd	N/A	23062787	N/A	N/A
Test Software	ELEKTRA	ELEKTRA4.32	N/A	N/A	N/A
Open Switch and Control Unit	R&S	OSP220	101964	Oct.01,22	Sep.30,24
DC Source	HYELEC	HY3010B	551016	Aug.31,22	Aug.30,24
DC Source	HYELEC	HY3010B	551016	Aug.30,24	Aug.29,26
Hygrothermograph	DELI	20210528	SZ014	Sep.06,22	Sep.05,24
Hygrothermograph	DELI	20210528	SZ014	Sep.05,24	Sep.04,26
PC	LENOVO	E14	HRSW0024	N/A	N/A
TMC-AMI18843A(CABLE)	R&S	HF290-NMNM-7.00M	N/A	N/A	N/A
TMC-AMI18843A(CABLE)	R&S	HF290-NMNM-4.00M	N/A	N/A	N/A
CABLE	R&S	W13.02	N/A	Apr.27,24	Apr.26,25
CABLE	R&S	W12.14	N/A	Apr.27,24	Apr.26,25
CABLE	R&S	J12J103539-00-1	SEP-03-20-0	Apr.27,24	Apr.26,25



			69		
CABLE	R&S	J12J103539-00-1	SEP-03-20-070	Apr.27,24	Apr.26,25
Temperature Chamber	votsch	VT4002	58566078100050	May.30,24	May.29,26

- NOTE:** 1. The calibration interval of the above test instruments is 12/ 24 / 36 months and the calibrations are traceable to CEPREI/CHINA, GRGT/CHINA and NIM/CHINA.
 2. The test was performed in 3m Semi-anechoic Chamber and RF Oven Room.
 3. The horn antenna is used only for the measurement of emission frequency above 1GHz if tested.
 4. The FCC Site Registration No. is 434559; The Designation No. is CN1325.

Lab B:

Equipment	Manufacturer	Model No.	Serial No.	Last Cal.	Next Cal.
MXE EMI Receiver	KEYSIGHT	N9038A-544	MY54450026	Mar. 27,24	Mar. 26,25
EXA Signal Analyzer	KEYSIGHT	N9010A-544	MY54510355	May.09,24	May.08,25
Loop Antenna	Schwarzbeck	FMZB 1519B	00173	Sep.02,23	Sep.01,24
Loop Antenna	Schwarzbeck	FMZB 1519B	00173	Sep.01,24	Aug.30,25
Bilog Antenna	ETS-LINDGR EN	3143B	00161965	Feb. 17,24	Feb. 16,25
Horn Antenna	ETS-LINDGR EN	3117	00168692	Feb. 17,24	Feb. 16,25
Horn Antenna (18GHz-40GHz)	N/A	QWH-SL-18-40- K-SG/QMS-0036 1	15433	Sep.03, 23	Sep.02, 24
Horn Antenna (18GHz-40GHz)	N/A	QWH-SL-18-40- K-SG/QMS-0036 1	15433	Sep.02, 24	Sep.01, 25
Radio Communication Analyzer	ANRITSU	MT8820C	6201465426	Feb. 13,24	Feb. 12,25
Signal Pre-Amplifier	EMSI	EMC 9135	980249	May. 05,24	May. 04,25
Signal Pre-Amplifier	EMSI	EMC 012645B	980257	May.09,24	May.08,25
Signal Pre-Amplifier	EMSI	EMC 184045B	980259	Feb.16,24	Feb.15,25
3m Semi-anechoic Chamber	ETS-LINDGR EN	9m*6m*6m	Euroshieldpn- CT0001143-12 16	Nov. 14,23	Nov. 13,26
Test Software	E3	V 9.160323	N/A	N/A	N/A
Test Software	JS1120	3.1.36	N/A	N/A	N/A
10dB Attenuator	JFW/USA	50HF-010-SMA	50HF-010-SM A	May. 05,24	May. 04,26
Power Meter	Anritsu	ML2495A	1506002	Feb. 13,24	Feb. 12,25
Power Sensor	Anritsu	MA2411B	1339352	Feb. 13,24	Feb. 12,25
Temperature Chamber	ESPEC	SH-242	93000855	May. 05,24	May. 04,25
MXG Analog Microwave Signal Generator	KEYSIGHT	N5183A	MY50143024	Feb. 13,24	Feb. 12,25
Base station R&S CMW500	Rohde&Schw arz	CMW500	153085	May.09,24	May.08,25
DC Source	Kikusui/JP	PMX18-5A	N/A	Aug. 11,23	Aug. 10,24
DC Source	Kikusui/JP	PMX18-5A	N/A	Aug. 10,24	Aug. 09,26



Test Report No.: PSU-NQN2406210109RF01

- NOTE:**
1. The calibration interval of the above test instruments is 12/ 36 months and the calibrations are traceable to CEPREI/CHINA, GRGT/CHINA and NIM/CHINA.
 2. The test was performed in 3m Semi-anechoic Chamber and RF Oven Room.
 3. The horn antenna is used only for the measurement of emission frequency above 1GHz if tested.
 4. The FCC Site Registration No. is 525120; The Designation No. is CN1171.



2 GENERAL INFORMATION

2.1 GENERAL DESCRIPTION OF EUT

PRODUCT*	Smart Phone	
BRAND NAME*	RugGear	
MODEL NAME*	PSM05G	
MARKETING NAME*	RG880i	
NOMINAL VOLTAGE*	5.0Vdc/ 9.0Vdc/ 12.0Vdc(Adapter) 3.85Vdc (Battery)	
MODULATION TYPE	GSM/EDGE	GMSK, 8PSK
	CDMA2000 BC0	1xRTT: BPSK, QPSK 1xEV-DO: 8PSK
	WCDMA	BPSK, QPSK
	LTE	QPSK, 16QAM, 64QAM
FREQUENCY RANGE	GSM/EDGE	824.2MHz ~ 848.8MHz
	CDMA2000 BC0	824.7MHz ~ 848.31 MHz
	WCDMA	826.4MHz ~ 846.6MHz
	LTE Band 5 (Channel Bandwidth: 1.4MHz)	824.7MHz ~ 848.3MHz
	LTE Band 5 (Channel Bandwidth: 3MHz)	825.5MHz ~ 847.5MHz
	LTE Band 5 (Channel Bandwidth: 5MHz)	826.5MHz ~ 846.5MHz
	LTE Band 5 (Channel Bandwidth: 10MHz)	829MHz ~ 844MHz
MAX. ERP POWER	GSM	732.82mW
	EDGE	187.93mW
	CDMA2000 BC0 1xRTT	90.36mW
	CDMA2000 BC0 1xEV-DO	89.33mW
	WCDMA	87.1mW
	LTE Band 5 (Channel Bandwidth: 1.4MHz)	86.9mW
	LTE Band 5 (Channel Bandwidth: 3MHz)	85.9mW
	LTE Band 5 (Channel Bandwidth: 5MHz)	85.9mW
	LTE Band 5 (Channel Bandwidth: 10MHz)	87.7mW
EMISSION	GSM	246KGXW



DESIGNATOR GOGN	EDGE	248KG7W
	CDMA2000 BC0	1M48F9W
	WCDMA	4M12F9W
	LTE Band 5 (Channel Bandwidth: 1.4MHz)	QPSK: 1M10G7D
		16QAM: 1M09W7D
		64QAM: 1M10W7D
	LTE Band 5 (Channel Bandwidth: 3MHz)	QPSK: 2M70G7D
		16QAM: 2M69W7D
		64QAM: 2M70W7D
	LTE Band 5 (Channel Bandwidth: 5MHz)	QPSK: 4M49G7D
		16QAM: 4M50W7D
		64QAM: 4M49W7D
	LTE Band 5 (Channel Bandwidth: 10MHz)	QPSK: 8M96G7D
16QAM: 8M96W7D		
64QAM: 8M96W7D		
ANTENNA TYPE*	PIFA Antenna with -1.6dBi gain for GSM850/ CDMA2000 BC 0/WCDMA V/LTE B5	
HW VERSION*	V02	
SW VERSION*	RG880i_EAA_00.00_1	
I/O PORTS*	Refer to user's manual	
CABLE SUPPLIED*	USB cable: non-shielded cable, with w/o ferrite core, 1.0 meter	
EXTREME TEMPERATURE*	-10°C-55°C	
EXTREME VOLTAGE*	3.6V – 4.4V	

NOTE:

- *Since the above data and/or information is provided by the client relevant results or conclusions of this report are only made for these data and/or information, Test Lab is not responsible for the authenticity, integrity and results of the data and information and/or the validity of the conclusion.
- For a more detailed features description, please refer to the manufacturer's specifications or the user's manual.
- The EUT incorporates a SISO function. Physically, the EUT provides one completed transmitter and two receivers.

MODULATION MODE	TX FUNCTION
GSM/GPRS/EDGE	1TX
WCDMA	1TX
CDMA2000BC0	1TX
LTE	1TX

- For the test results, the EUT had been tested with all conditions. But only the worst case was shown in the test report.



5. List of Accessory:

ACCESSORIES	BRAND	MANUFACTURER	MODEL	SPECIFICATION
CPU	QUALCOMM	N/A	SM6225	N/A
eMMC 1 (=ROM 1)	SAMSUNG	N/A	KM2L9001CM-B518	N/A
eMMC 2 (=ROM 2)	Hynix	N/A	H9QT0GECN6X145R	N/A
RAM 1	N/A	N/A	N/A	N/A
RAM 2	N/A	N/A	N/A	N/A
BT/WLAN Module	N/A	N/A	N/A	N/A
NFC chipset	NXP	N/A	N/A	N/A
Battery	N/A	N/A	BL450AGP	Power Rating: 4.4V 4500mAh
Adapter	N/A	Huizhou Juwei Electronics Co.,Ltd	FG18AQC3.0UU	I/P: 100-240Vac, 50/60Hz, 0.5A, O/P:5.0V 3.0A or 9.0V 2.0A or 12.0V 1.5A
USB Cable	N/A	N/A	N/A	N/A



2.2 CONFIGURATION OF SYSTEM UNDER TEST FOR RADIATION EMISSION

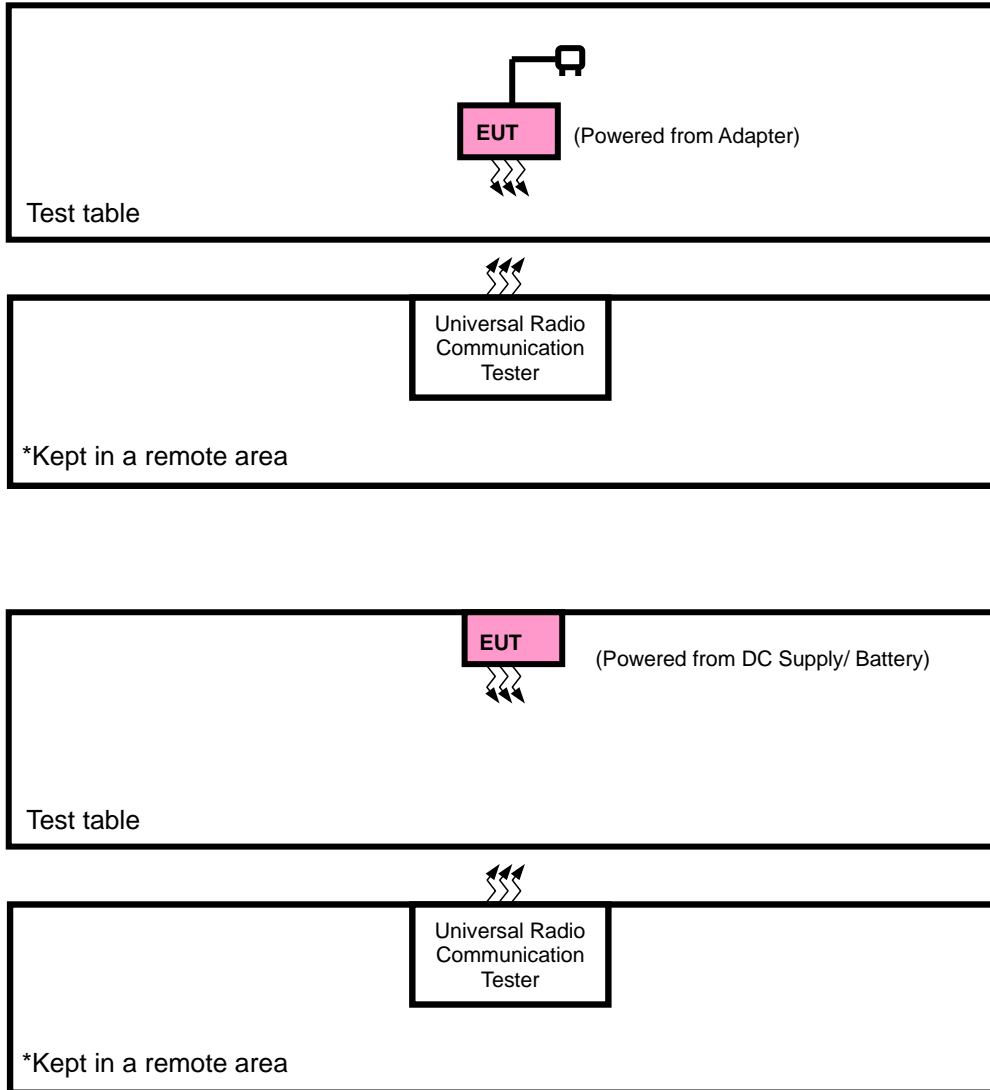



2.3 DESCRIPTION OF SUPPORT UNITS

The EUT has been tested as an independent unit together with other necessary accessories or support units. The following support units or accessories were used to form a representative test configuration during the tests.

NO.	PRODUCT	BRAND	MODEL NO.	SERIAL NO.	FCC ID
1	N/A	N/A	N/A	N/A	N/A

NO.	SIGNAL CABLE DESCRIPTION OF THE ABOVE SUPPORT UNITS
1	USB Line: Shielded, Detachable 1.0m;

2.4 TEST ITEM AND TEST CONFIGURATION

Pre-Scan has been conducted to determine the worst-case mode from all possible combinations between available modulations, data rates, XYZ axis and antenna ports. The worst case in ERP and radiated emission was found when positioned on X-plane for GSM /EDGE /LTE. Following channel(s) was (were) selected for the final test as listed below:

EUT CONFIGURE MODE	DESCRIPTION
A	EUT + Adapter + USB Cable with GSM or CDMA2000 or WCDMA or LTE link
B	EUT + Battery / DC Supply with GSM or CDMA2000 or WCDMA or LTE link

GSM MODE

EUT CONFIGURE MODE	TEST ITEM	AVAILABLE CHANNEL	TESTED CHANNEL	MODE
A	ERP	128 to 251	128, 189, 251	GSM, EDGE
B	FREQUENCY STABILITY	128 to 251	128, 189, 251	GSM, EDGE
A	OCCUPIED BANDWIDTH	128 to 251	128, 189, 251	GSM, EDGE
A	BAND EDGE	128 to 251	128, 251	GSM, EDGE
A	CONDUCTED EMISSION	128 to 251	128, 189, 251	GSM, EDGE
A	RADIATED EMISSION	128 to 251	128, 189, 251	GSM, EDGE
A	PEAK TO AVERAGE RATIO	128 to 251	128, 189, 251	GSM, EDGE



CDMA2000 BC0

EUT CONFIGURE MODE	TEST ITEM	AVAILABLE CHANNEL	TESTED CHANNEL	MODE
A	ERP	1013 to 777	1013, 384, 777	CDMA
B	FREQUENCY STABILITY	1013 to 777	1013, 384, 777	CDMA
A	OCCUPIED BANDWIDTH	1013 to 777	1013, 384, 777	CDMA
A	BAND EDGE	1013 to 777	1013, 777	CDMA
A	CONDCUDETED EMISSION	1013 to 777	1013, 384, 777	CDMA
A	RADIATED EMISSION	1013 to 777	1013, 384, 777	CDMA
A	PEAK TO AVERAGE RATIO	1013 to 777	1013, 384, 777	CDMA

WCDMA MODE

EUT CONFIGURE MODE	TEST ITEM	AVAILABLE CHANNEL	TESTED CHANNEL	MODE
A	ERP	4132 to 4233	4132, 4182, 4233	WCDMA
B	FREQUENCY STABILITY	4132 to 4233	4132, 4182, 4233	WCDMA
A	OCCUPIED BANDWIDTH	4132 to 4233	4132, 4182, 4233	WCDMA
A	BAND EDGE	4132 to 4233	4132, 4233	WCDMA
A	CONDCUDETED EMISSION	4132 to 4233	4132, 4182, 4233	WCDMA
A	RADIATED EMISSION	4132 to 4233	4132, 4182, 4233	WCDMA
A	PEAK TO AVERAGE RATIO	4132 to 4233	4132, 4182, 4233	WCDMA



LTE BAND 5 MODE

EUT CONFIGURE MODE	TEST ITEM	Available Channel	Tested Channel	Channel bandwidth	modulation	mode
A	ERP	20407 to 20643	20407, 20525, 20643	1.4MHz	QPSK,16QAM,64QAM	1 RB / 0 RB Offset
		20415 to 20635	20415, 20525, 20635	3MHz	QPSK,16QAM,64QAM	1 RB / 0 RB Offset
		20425 to 20625	20425, 20525, 20625	5MHz	QPSK,16QAM,64QAM	1 RB / 0 RB Offset
		20450 to 20600	20450, 20525, 20600	10MHz	QPSK,16QAM,64QAM	1 RB / 0 RB Offset
B	FREQUENCY STABILITY	20450 to 20600	20450, 20525, 20600	10MHz	QPSK,16QAM,64QAM	Full RB / 0 RB Offset
A	OCCUPIED BANDWIDTH	20407 to 20643	20407, 20525, 20643	1.4MHz	QPSK,16QAM,64QAM	Full RB / 0 RB Offset
		20415 to 20635	20415, 20525, 20635	3MHz	QPSK,16QAM,64QAM	Full RB / 0 RB Offset
		20425 to 20625	20425, 20525, 20625	5MHz	QPSK,16QAM,64QAM	Full RB / 0 RB Offset
		20450 to 20600	20450, 20525, 20600	10MHz	QPSK,16QAM,64QAM	Full RB / 0 RB Offset
A	BAND EDGE	20407 to 20643	20407	1.4 MHz	QPSK,16QAM,64QAM	1 RB / 0 RB Offset
						Full RB / 0 RB Offset
		20407 to 20643	20643	1.4 MHz	QPSK,16QAM,64QAM	1 RB / 5 RB Offset
						Full RB / 0 RB Offset
		20415 to 20635	20415	3 MHz	QPSK,16QAM,64QAM	1 RB / 0 RB Offset
						Full RB / 0 RB Offset
		20415 to 20635	20635	3 MHz	QPSK,16QAM,64QAM	1 RB / 14 RB Offset
						Full RB / 0 RB Offset
		20425 to 20625	20425	5MHz	QPSK,16QAM,64QAM	1 RB / 0 RB Offset
						Full RB / 0 RB Offset
		20425 to 20625	20625	5MHz	QPSK,16QAM,64QAM	1 RB / 24 RB Offset
						Full RB / 0 RB Offset
		20450 to 20600	20450	10MHz	QPSK,16QAM,64QAM	1 RB / 0 RB Offset
						Full RB / 0 RB Offset
		20450 to 20600	20600	10MHz	QPSK,16QAM,64QAM	1 RB / 49 RB Offset
						Full RB / 0 RB Offset



A	CONDCUDED EMISSION	20407 to 20643	20407, 20525, 20643	1.4MHz	QPSK,16QAM,64QAM	1 RB / 0 RB Offset
		20415 to 20635	20415, 20525, 20635	3MHz	QPSK,16QAM,64QAM	1 RB / 0 RB Offset
		20425 to 20625	20425, 20525, 20625	5MHz	QPSK,16QAM,64QAM	1 RB / 0 RB Offset
		20450 to 20600	20450, 20525, 20600	10MHz	QPSK,16QAM,64QAM	1 RB / 0 RB Offset
A	RADIATED EMISSION	20407 to 20643	20407, 20525, 20643	1.4MHz	QPSK	1 RB / 0 RB Offset
		20415 to 20635	20525	3MHz	QPSK	1 RB / 0 RB Offset
		20425 to 20625	20525	5MHz	QPSK	1 RB / 0 RB Offset
		20450 to 20600	20525	10MHz	QPSK	1 RB / 0 RB Offset
A	PEAK TO AVERAGE RATIO	20407 to 20643	20407, 20525, 20643	1.4MHz	QPSK,16QAM,64QAM	1 RB / 0 RB Offset Full RB / 0 RB Offset
		20415 to 20635	20415, 20525, 20635	3MHz	QPSK,16QAM,64QAM	1 RB / 0 RB Offset Full RB / 0 RB Offset
		20425 to 20625	20425, 20525, 20625	5MHz	QPSK,16QAM,64QAM	1 RB / 0 RB Offset Full RB / 0 RB Offset
		20450 to 20600	20450, 20525, 20600	10MHz	QPSK,16QAM,64QAM	1 RB / 0 RB Offset Full RB / 0 RB Offset

Note: This device was tested under all bandwidths, RB configurations and modulations. The worst case was found in QPSK modulation.



TEST CONDITION:

TEST ITEM	ENVIRONMENTAL CONDITIONS	INPUT POWER	TESTED BY
ERP	23deg. C, 70%RH	DC 5.0V/ 9.0V/ 12.0V By Adapter	Hanwen Xu
FREQUENCY STABILITY	23deg. C, 70%RH	DC 3.6V/ 3.85V/ 4.4V By Battery	Hanwen Xu/ Jace Hu
OCCUPIED BANDWIDTH	23deg. C, 70%RH	DC 5.0V/ 9.0V/ 12.0V By Adapter	Hanwen Xu/ Jace Hu
BAND EDGE	23deg. C, 70%RH	DC 5.0V/ 9.0V/ 12.0V By Adapter	Hanwen Xu/ Jace Hu
CONDCUDED EMISSION	23deg. C, 70%RH	DC 5.0V/ 9.0V/ 12.0V By Adapter	Hanwen Xu/ Jace Hu
RADIATED EMISSION	23deg. C, 70%RH	DC 5.0V/ 9.0V/ 12.0V By Adapter	Hanwen Xu/ Jace Hu
PEAK TO AVERAGE RATIO	23deg. C, 70%RH	DC 5.0V/ 9.0V/ 12.0V By Adapter	Hanwen Xu/ Jace Hu

2.5 EUT OPERATING CONDITIONS

The EUT makes a call to the communication simulator. The communication simulator station system controlled a EUT to export maximum output power under transmission mode and specific channel frequency



2.6 GENERAL DESCRIPTION OF APPLIED STANDARDS

The EUT is a RF product. According to the specifications of the manufacturer, it must comply with the requirements of the following standards:

FCC 47 CFR Part 2

FCC 47 CFR Part 22

KDB 971168 D01 Power Meas License Digital Systems v03r01

ANSI/TIA/EIA-603-D

ANSI/TIA/EIA-603-E

ANSI C63.26-2015

NOTE: All test items have been performed and recorded as per the above standards.



3 TEST TYPES AND RESULTS

3.1 OUTPUT POWER MEASUREMENT

3.1.1 LIMITS OF OUTPUT POWER MEASUREMENT

Mobile / Portable station are limited to 7 watts e.r.p.

3.1.2 TEST PROCEDURES

EIRP / ERP MEASUREMENT:

Per KDB 971168 D01 Power Meas License Digital Systems v03r01 or subclause 5.2.5.5 of ANSI C63.26-2015, the relevant equation for determining the ERP or EIRP from the conducted RF output power measured using the guidance provided above is:

$$\text{ERP or EIRP} = P_{\text{Meas}} + G_{\text{T}} - L_{\text{C}}$$

Where:

ERP or EIRP = effective radiated power or equivalent isotropically radiated power, respectively

(expressed in the same units as P_{Meas} , typically dBW or dBm);

P_{Meas} = measured transmitter output power or PSD, in dBm or dBW;

G_{T} = gain of the transmitting antenna, in dBd (ERP) or dBi (EIRP);

L_{C} = signal attenuation in the connecting cable between the transmitter and antenna, in dB.

CONDUCTED POWER MEASUREMENT:

The EUT was set up for the maximum power with WCDMA link data modulation and link up with simulator. Set the EUT to transmit under low, middle and high channel and record the power level shown on simulator.



3.1.3 TEST SETUP

EIRP / ERP Measurement:

CONDUCTED POWER MEASUREMENT:

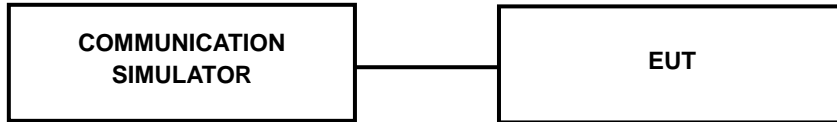

3.1.4 TEST RESULTS

CONDUCTED OUTPUT POWER (dBm):

Band	GSM850		
Channel	128	189	251
Frequency(MHz)	824.2	836.4	848.8
GSM	32.40	32.36	32.36
GPRS 1Tx Slot	32.38	32.35	32.33
GPRS 2Tx Slot	29.61	29.30	29.37
GPRS 3Tx Slot	27.44	27.33	27.26
GPRS 4Tx Slot	25.54	25.53	25.28
EDGE 1Tx Slot	26.49	26.31	26.30
EDGE 2Tx Slot	25.81	25.52	25.46
EDGE 3Tx Slot	24.82	24.68	24.62
EDGE 4Tx Slot	24.17	24.04	23.96

Band	CDMA2000 BC0		
Channel	1013	384	777
Frequency(MHz)	824.7	836.52	848.31
RC1 SO55	23.28	23.31	23.17
RC3 SO55	23.26	23.30	23.16
RC3 SO32 (F+SCH)	23.25	23.30	23.15
RC3 SO32 (+SCH)	23.23	23.28	23.13
RTAP 153.6Kbps	23.22	23.26	23.11
RETAP 4096Bits	23.20	23.24	23.10



Band	WCDMA V		
TX Channel	4132	4182	4233
Rx Channel	4357	4407	4458
Frequency(MHz)	826.4	836.4	846.6
RMC 12.2K	23.07	23.11	23.15
HSDPA Subtest-1	22.49	22.53	22.57
HSDPA Subtest-2	22.48	22.52	22.56
HSDPA Subtest-3	21.97	22.01	22.05
HSDPA Subtest-4	21.96	22.00	22.04
DC-HSDPA Subtest-1	22.41	22.47	22.49
DC-HSDPA Subtest-2	22.40	22.46	22.48
DC-HSDPA Subtest-3	21.98	21.95	21.99
DC-HSDPA Subtest-4	21.97	21.94	21.98
HSUPA Subtest-1	22.45	22.49	22.53
HSUPA Subtest-2	21.44	21.48	21.52
HSUPA Subtest-3	21.92	21.97	22.01
HSUPA Subtest-4	21.41	21.46	21.50
HSUPA Subtest-5	22.40	22.45	22.49
HSPA+ Subtest-1	21.96	22.02	22.06



LTE Band 5

Band/BW	Modulation	RB Size	RB Offset	Low CH 20407	Mid CH 20525	High CH 20643
				Frequency 824.7 MHz	Frequency 836.5 MHz	Frequency 848.3 MHz
5/ 1.4	QPSK	1	0	23.11	22.75	22.86
		1	2	23.08	22.95	23.09
		1	5	23.14	22.94	22.83
		3	0	22.81	22.74	22.54
		3	1	22.91	22.76	22.71
		3	3	22.84	22.72	22.58
		6	0	21.82	21.68	21.58
	16QAM	1	0	22.22	21.84	21.89
		1	2	22.12	21.77	21.64
		1	5	22.28	22.16	21.91
		3	0	21.69	21.70	21.56
		3	1	21.85	21.75	21.61
		3	3	21.91	21.74	21.60
		6	0	20.57	20.70	20.51
	64QAM	1	0	20.78	21.00	20.88
		1	2	20.72	20.97	20.75
		1	5	21.07	21.15	20.87
		3	0	20.68	20.73	20.64
		3	1	20.68	20.68	20.61
		3	3	20.75	20.74	20.57
		6	0	19.75	19.64	19.52



Band/BW	Modulation	RB Size	RB Offset	Low CH 20415	Mid CH 20525	High CH 20635
				Frequency 825.5 MHz	Frequency 836.5 MHz	Frequency 847.5 MHz
5/3	QPSK	1	0	23.08	22.82	22.82
		1	7	23.05	22.92	23.02
		1	14	23.09	22.87	22.79
		8	0	21.78	21.68	21.62
		8	3	21.88	21.73	21.62
		8	7	21.82	21.60	21.62
		15	0	21.75	21.68	21.54
	16QAM	1	0	22.15	21.80	21.96
		1	7	22.12	21.79	21.65
		1	14	22.24	22.16	21.92
		8	0	20.76	20.65	20.60
		8	3	20.97	20.79	20.59
		8	7	20.90	20.71	20.67
		15	0	20.59	20.75	20.48
	64QAM	1	0	20.80	21.01	20.93
		1	7	20.86	20.95	20.73
		1	14	21.07	21.17	20.94
		8	0	19.58	19.70	19.53
		8	3	19.66	19.68	19.67
		8	7	19.67	19.72	19.53
		15	0	19.65	19.60	19.64



Band/BW	Modulation	RB Size	RB Offset	Low CH 20425	Mid CH 20525	High CH 20625
				Frequency 826.5 MHz	Frequency 836.5 MHz	Frequency 846.5 MHz
5/ 5	QPSK	1	0	23.06	22.81	22.77
		1	12	23.09	23.01	23.07
		1	24	23.03	22.93	22.84
		12	0	21.80	21.63	21.62
		12	6	21.94	21.81	21.67
		12	13	21.86	21.66	21.68
		25	0	21.83	21.71	21.64
	16QAM	1	0	22.22	21.81	21.83
		1	12	22.06	21.78	21.64
		1	24	22.26	22.10	21.87
		12	0	20.72	20.65	20.55
		12	6	20.91	20.67	20.58
		12	13	20.94	20.74	20.65
		25	0	20.62	20.65	20.50
	64QAM	1	0	20.76	20.98	20.94
		1	12	20.74	20.91	20.81
		1	24	21.02	21.13	20.91
		12	0	19.62	19.67	19.65
		12	6	19.74	19.69	19.63
		12	13	19.72	19.62	19.60
		25	0	19.63	19.64	19.52



Band/BW	Modulation	RB Size	RB Offset	Low CH 20450	Mid CH 20525	High CH 20600
				Frequency 829 MHz	Frequency 836.5 MHz	Frequency 844 MHz
5/ 10	QPSK	1	0	23.12	22.87	22.92
		1	24	23.18	23.04	23.13
		1	49	23.16	22.95	22.91
		25	0	21.89	21.77	21.67
		25	12	22.01	21.84	21.77
		25	25	21.92	21.75	21.72
		50	0	21.87	21.73	21.69
	16QAM	1	0	22.27	21.94	21.97
		1	24	22.16	21.84	21.77
		1	49	22.34	22.21	22.02
		25	0	20.80	20.78	20.68
		25	12	20.99	20.80	20.72
		25	25	20.97	20.82	20.69
		50	0	20.72	20.76	20.63
	64QAM	1	0	20.91	21.13	21.01
		1	24	20.87	21.06	20.82
		1	49	21.12	21.20	20.97
		25	0	19.71	19.75	19.68
		25	12	19.79	19.72	19.69
		25	25	19.78	19.76	19.67
		50	0	19.76	19.75	19.66



ERP POWER (dBm)

GSM 850

Channel	Frequency (MHz)	Conducted Power (dBm)	G _T -L _C (dB)	ERP (dBm)	ERP (mW)	Limit (W)
128	824.2	32.4	-1.6	28.65	732.82	7
190	836.6	32.36	-1.6	28.61	726.11	7
251	848.8	32.36	-1.6	28.61	726.11	7

EDGE 850

Channel	Frequency (MHz)	Conducted Power (dBm)	G _T -L _C (dB)	ERP (dBm)	ERP (mW)	Limit (W)
128	824.2	26.49	-1.6	22.74	187.93	7
190	836.6	26.31	-1.6	22.56	180.3	7
251	848.8	26.3	-1.6	22.55	179.89	7

CDMA2000 BC0 1xRTT

Channel	Frequency (MHz)	Conducted Power (dBm)	G _T -L _C (dB)	ERP (dBm)	ERP (mW)	Limit (W)
1013	824.7	23.28	-1.6	19.53	89.74	7
384	836.52	23.31	-1.6	19.56	90.36	7
777	848.31	23.17	-1.6	19.42	87.5	7

CDMA2000 BC0 1xEV-DO

Channel	Frequency (MHz)	Conducted Power (dBm)	G _T -L _C (dB)	ERP (dBm)	ERP (mW)	Limit (W)
1013	824.7	23.22	-1.6	19.47	88.51	7
384	836.52	23.26	-1.6	19.51	89.33	7
777	848.31	23.11	-1.6	19.36	86.3	7

WCDMA V

Channel	Frequency (MHz)	Conducted Power (dBm)	G _T -L _C (dB)	ERP (dBm)	ERP (mW)	Limit (W)
4132	826.4	23.07	-1.6	19.32	85.51	7
4182	836.4	23.11	-1.6	19.36	86.3	7
4233	846.6	23.15	-1.6	19.4	87.1	7

REMARKS: ERP Output Power (dBm) = EIRP (dBm) -2.15(dB).



LTE BAND 5

CHANNEL BANDWIDTH: 1.4MHz QPSK

Channel	Frequency (MHz)	Conducted Power (dBm)	G _T -L _C (dB)	ERP (dBm)	ERP (mW)	Limit (W)
20407	824.7	23.14	-1.6	19.39	86.9	7
20525	836.5	22.95	-1.6	19.2	83.18	7
20643	848.3	23.09	-1.6	19.34	85.9	7

CHANNEL BANDWIDTH: 1.4MHz 16QAM

Channel	Frequency (MHz)	Conducted Power (dBm)	G _T -L _C (dB)	ERP (dBm)	ERP (mW)	Limit (W)
20407	824.7	22.28	-1.6	18.53	71.29	7
20525	836.5	22.16	-1.6	18.41	69.34	7
20643	848.3	21.91	-1.6	18.16	65.46	7

CHANNEL BANDWIDTH: 1.4MHz 64QAM

Channel	Frequency (MHz)	Conducted Power (dBm)	G _T -L _C (dB)	ERP (dBm)	ERP (mW)	Limit (W)
20407	824.7	21.07	-1.6	17.32	53.95	7
20525	836.5	21.15	-1.6	17.4	54.95	7
20643	848.3	20.88	-1.6	17.13	51.64	7



CHANNEL BANDWIDTH: 3MHz QPSK

Channel	Frequency (MHz)	Conducted Power (dBm)	G _{T-L_C} (dB)	ERP (dBm)	ERP (mW)	Limit (W)
20415	825.5	23.09	-1.6	19.34	85.9	7
20525	836.5	22.92	-1.6	19.17	82.6	7
20635	847.5	23.02	-1.6	19.27	84.53	7

CHANNEL BANDWIDTH: 3MHz 16QAM

Channel	Frequency (MHz)	Conducted Power (dBm)	G _{T-L_C} (dB)	ERP (dBm)	ERP (mW)	Limit (W)
20415	825.5	22.24	-1.6	18.49	70.63	7
20525	836.5	22.16	-1.6	18.41	69.34	7
20635	847.5	21.96	-1.6	18.21	66.22	7

CHANNEL BANDWIDTH: 3MHz 64QAM

Channel	Frequency (MHz)	Conducted Power (dBm)	G _{T-L_C} (dB)	ERP (dBm)	ERP (mW)	Limit (W)
20415	825.5	21.07	-1.6	17.32	53.95	7
20525	836.5	21.17	-1.6	17.42	55.21	7
20635	847.5	20.94	-1.6	17.19	52.36	7



CHANNEL BANDWIDTH: 5MHz QPSK

Channel	Frequency (MHz)	Conducted Power (dBm)	G _T -L _C (dB)	ERP (dBm)	ERP (mW)	Limit (W)
20425	826.5	23.09	-1.6	19.34	85.9	7
20525	836.5	23.01	-1.6	19.26	84.33	7
20625	846.5	23.07	-1.6	19.32	85.51	7

CHANNEL BANDWIDTH: 5MHz 16QAM

Channel	Frequency (MHz)	Conducted Power (dBm)	G _T -L _C (dB)	ERP (dBm)	ERP (mW)	Limit (W)
20425	826.5	22.26	-1.6	18.51	70.96	7
20525	836.5	22.1	-1.6	18.35	68.39	7
20625	846.5	21.87	-1.6	18.12	64.86	7

CHANNEL BANDWIDTH: 5MHz 64QAM

Channel	Frequency (MHz)	Conducted Power (dBm)	G _T -L _C (dB)	ERP (dBm)	ERP (mW)	Limit (W)
20425	826.5	21.02	-1.6	17.27	53.33	7
20525	836.5	21.13	-1.6	17.38	54.7	7
20625	846.5	20.94	-1.6	17.19	52.36	7



CHANNEL BANDWIDTH: 10MHz QPSK

Channel	Frequency (MHz)	Conducted Power (dBm)	G _{T-Lc} (dB)	ERP (dBm)	ERP (mW)	Limit (W)
20450	829	23.18	-1.6	19.43	87.7	7
20525	836.5	23.04	-1.6	19.29	84.92	7
20600	844	23.13	-1.6	19.38	86.7	7

CHANNEL BANDWIDTH: 10MHz 16QAM

Channel	Frequency (MHz)	Conducted Power (dBm)	G _{T-Lc} (dB)	ERP (dBm)	ERP (mW)	Limit (W)
20450	829	22.34	-1.6	18.59	72.28	7
20525	836.5	22.21	-1.6	18.46	70.15	7
20600	844	22.02	-1.6	18.27	67.14	7

CHANNEL BANDWIDTH: 10MHz 64QAM

Channel	Frequency (MHz)	Conducted Power (dBm)	G _{T-Lc} (dB)	ERP (dBm)	ERP (mW)	Limit (W)
20450	829	21.12	-1.6	17.37	54.58	7
20525	836.5	21.2	-1.6	17.45	55.59	7
20600	844	21.01	-1.6	17.26	53.21	7

REMARKS: ERP Output Power (dBm) = EIRP (dBm) -2.15(dB).



3.2 FREQUENCY STABILITY MEASUREMENT

3.2.1 LIMITS OF FREQUENCY STABILITY MEASUREMENT

1.5 ppm is for base and fixed station. 2.5 ppm is for mobile station.

3.2.2 TEST PROCEDURE

- Device is placed at the oven room. The oven room could control the temperatures and humidity. Power warm up is at least 15 min and power applied should perform before recording frequency error.
- EUT is connected the external power supply to control the DC input power. The test voltage range is from minimum to maximum working voltage. Each step shall be record the frequency error rate.
- The temperature range step is 10 degrees in this test items. All temperature levels shall be hold the $\pm 0.5^{\circ}\text{C}$ during the measurement testing. The each temperature step shall be at least 0.5 hours, consider the EUT could be test under the stability condition.

NOTE: The frequency error was recorded frequency error from the communication simulator.

3.2.3 TEST SETUP

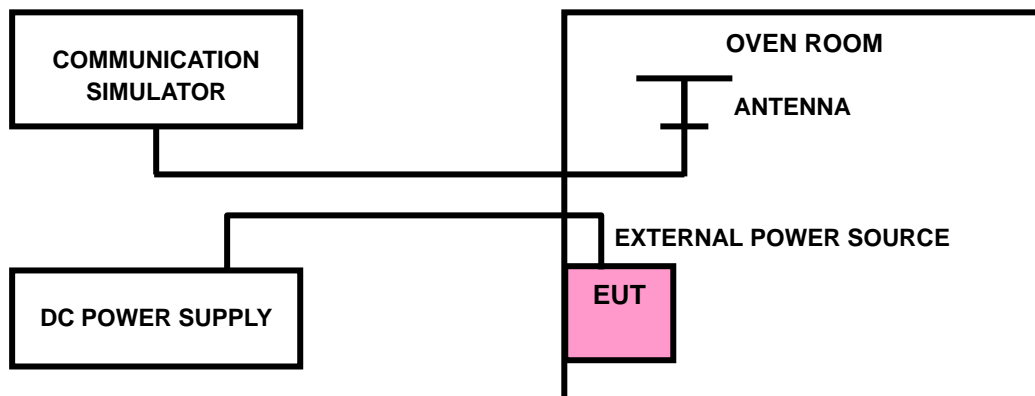



**BUREAU
VERITAS**

Test Report No.: PSU-NQN2406210109RF01

3.2.4 TEST RESULTS

Please Refer to Appendix Of this test report.

Note: VL = Low voltage(3.6V); VN/NV = Normal voltage(3.85V); VH = High voltage(4.4V);
NT = Normal temperature (25°C)



3.3 OCCUPIED BANDWIDTH MEASUREMENT

3.3.1 LIMITS OF OCCUPIED BANDWIDTH MEASUREMENT

The width of a frequency band such that, below the lower and above the upper frequency limits, the mean powers emitted are each equal to a specified percentage 0.5 %of the total mean power of a given emission.

3.3.2 TEST SETUP

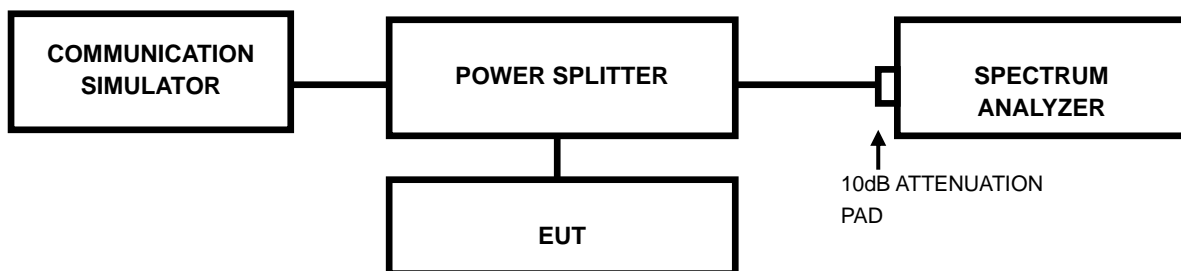

3.3.3 TEST PROCEDURES

- The conducted occupied bandwidth used the power splitter via EUT RF power connector between simulation base station and spectrum analyzer.
- Use OBW measurement function of Spectrum analyzer to measure 99 % occupied bandwidth.



Test Report No.: PSU-NQN2406210109RF01

3.3.4 TEST RESULTS

Please Refer to Appendix Of this test report.



3.4 BAND EDGE MEASUREMENT

3.4.1 LIMITS OF BAND EDGE MEASUREMENT

Power of any emission outside of the authorized operating frequency ranges must be attenuated below the transmitting power (P) by a factor of at least $43 + 10 \log(P)$ dB. In the 1 MHz bands immediately outside and adjacent to the frequency block a resolution bandwidth of at least one percent of the emission bandwidth of the fundamental emission of the transmitter may be employed.

3.4.2 TEST SETUP

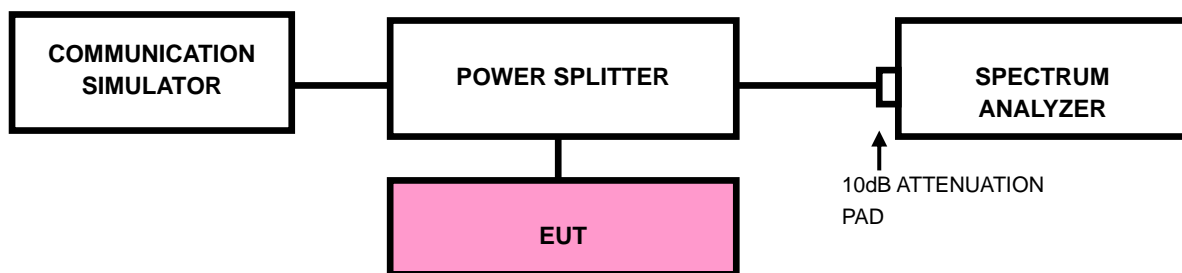



3.4.3 TEST PROCEDURES

- a) All measurements were done at low and high operational frequency range
- b) Connect the transmitter to the spectrum analyzer via coaxial cable while ensuring proper impedance matching.
- c) Tune the analyzer to the nominal center frequency of the emission bandwidth (EBW)
- d) .Set the resolution bandwidth (RBW) $\geq 1\%$ EBW in the 1MHz band immediately outside and adjacent to the band edge.
- e) Beyond the 1MHz band from the band edge, RBW=1MHz was used.
- f) Set the video bandwidth (VBW) to $\geq 3 \times$ RBW.
- g) Select the average power (RMS) display detector.
- h) Set the number of measurement points to ≥ 1001 .
- i) Use auto-coupled sweep time.
- j) Perform the measurement over an interval of time when the transmission is continuous and at its maximum power level.
- k) The RF fundamental frequency should be excluded against the limit line in the operating frequency band and use RBW is 10KHz or 100KHz.
- l) Record the max trace plot into the test report.



Test Report No.: PSU-NQN2406210109RF01

3.4.4 TEST RESULTS

Please Refer to Appendix Of this test report.



3.5 CONDUCTED SPURIOUS EMISSIONS

3.5.1 LIMITS OF CONDUCTED SPURIOUS EMISSIONS MEASUREMENT

The power of any emission outside of the authorized operating frequency ranges must be attenuated below the transmitting power (P) by a factor of at least $43 + 10 \log(P)$ dB. The emission limit equal to -13dBm .

3.5.2 TEST PROCEDURE

- The EUT makes a phone call to the communication simulator. All measurements were done at low, middle and high operational frequency range.
- Measuring frequency range is from 9kHz up to a frequency including its 10th harmonic. 10dB attenuation pad is connected with spectrum. RBW=1MHz and VBW=3MHz is used for conducted emission measurement.

3.5.3 TEST SETUP

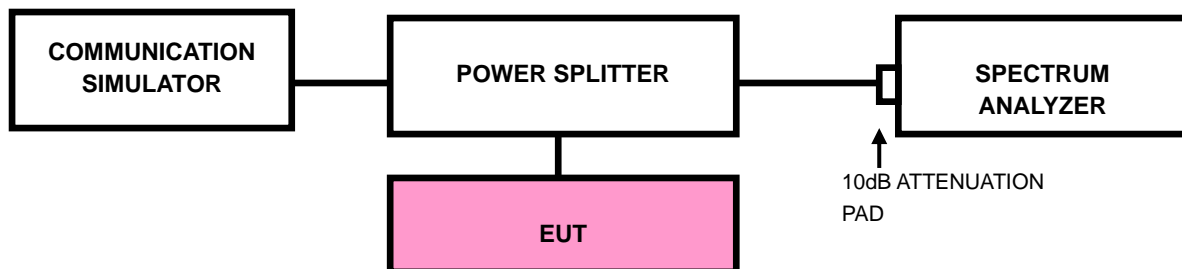



Test Report No.: PSU-NQN2406210109RF01

3.5.4 TEST RESULTS

NOTE : The 9K~30MHz amplitude of spurious emissions attenuated more than 20 dB below the permissible value is not required in the report.

Please Refer to Appendix Of this test report.



3.6 RADIATED EMISSION MEASUREMENT

3.6.1 LIMITS OF RADIATED EMISSION MEASUREMENT

The power of any emission outside of the authorized operating frequency ranges must be attenuated below the transmitting power (P) by a factor of at least $43 + 10 \log(P)$ dB. The emission limit equal to -13dBm .

3.6.2 TEST PROCEDURES

- a. Substitution method is used for E.I.R.P measurement. In the semi-anechoic chamber, EUT placed on the 0.8m height of Turn Table, rotated the table around 360 degrees to search the maximum radiation power and receiver antenna shall be rotated vertical and horizontal polarization and moved height from 1m to 4m to find the maximum polar radiated power. The "Read Value" is the spectrum reading the maximum power value.
- b. The substitution horn antenna is substituted for EUT at the same position and signals generator export the CW signal to the substitution antenna via a TX cable. Rotated the Turn Table and moved receiving antenna to find the maximum radiation power. Adjust output power level of S.G to get a Value of spectrum reading equal to "Read Value " of step a. Record the power level of S.G
- c. $\text{EIRP} = \text{Output power level of S.G} - \text{TX cable loss} + \text{Antenna gain of substitution horn.}$
- d. E.R.P power can be calculated form E.I.R.P power by subtracting the gain of dipole,
 $\text{E.R.P power} = \text{E.I.P.R power} - 2.15\text{dBi.}$

NOTE: The resolution bandwidth and video bandwidth of test receiver/spectrum analyzer is 1MHz/3MHz.

3.6.3 DEVIATION FROM TEST STANDARD

No deviation



3.6.4 TEST SETUP

< Frequency Range below 30MHz >

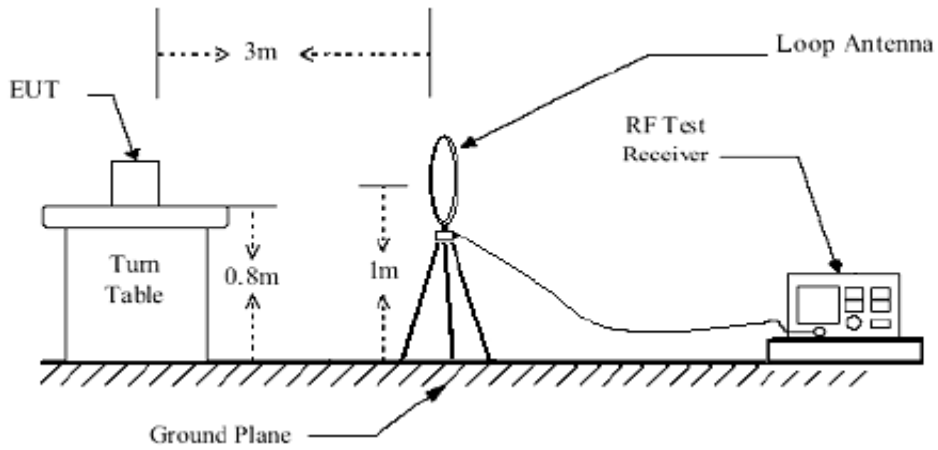

< Frequency Range 30MHz~1GHz >

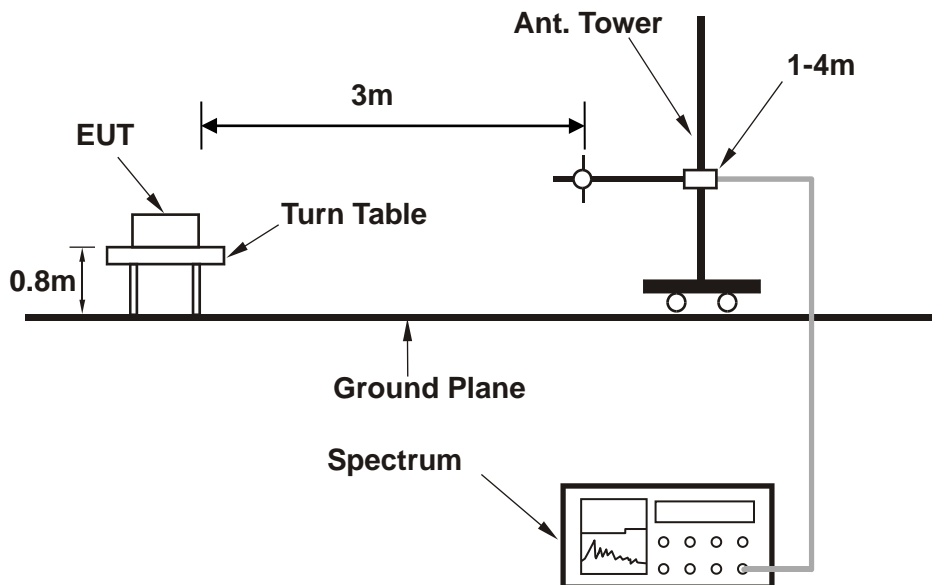



<Frequency Range above 1GHz>

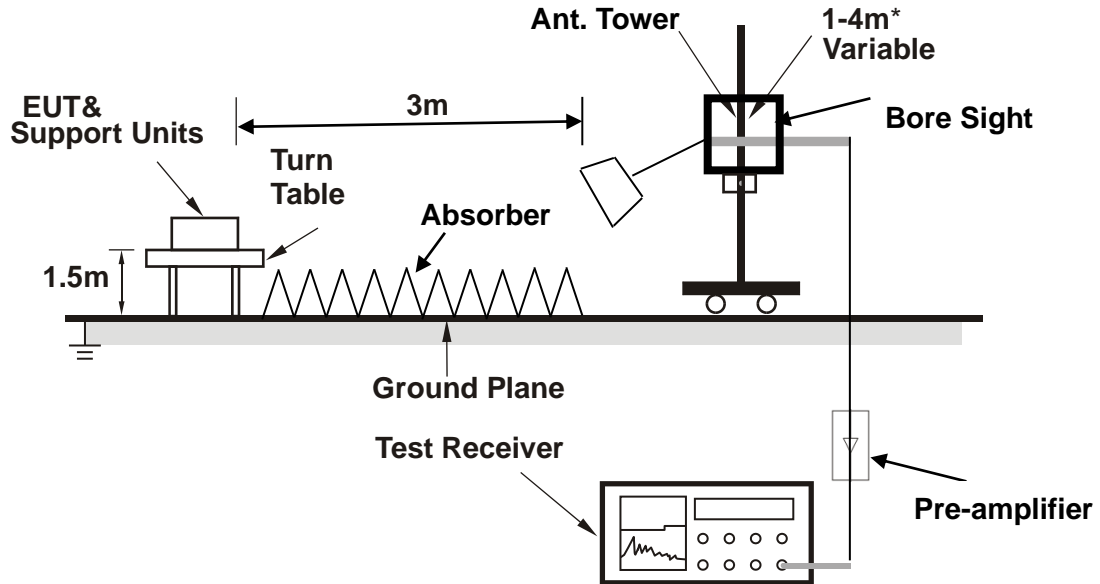

Note: Above 1G is a directional antenna

Depends on the EUT height and the antenna 3dB beamwidth both, refer to section 7.3 of CISPR 16-2-3.

For the actual test configuration, please refer to the attached file (Test Setup Photo).



3.6.5 TEST RESULTS

NOTE : The 9K~30MHz amplitude of spurious emissions attenuated more than 20 dB below the permissible value is not required in the report.

BELOW 1GHz WORST-CASE DATA

30 MHz – 1GHz data:

GSM 850:

CHANNEL BANDWIDTH: 128 ~ 251

MODE	TX channel 128	FREQUENCY RANGE	Below 1000MHz
ENVIRONMENTAL CONDITIONS	23deg. C, 70%RH	INPUT POWER	120Vac 60HZ
TESTED BY	Hanwen Xu		

ANTENNA POLARITY & TEST DISTANCE: HORIZONTAL AT 3 M

Rg	Frequency [MHz]	PK+ Level [dBm]	PK+ Limit [dBm]	PK+ Margin [dB]	Correction [dB]	Polarization	Azimuth [deg]	Antenna Height [m]
1	36.79	-56.49	-13.0	43.49	-1.56	H	4.9	1.0
1	64.435	-60.29	-13.0	47.29	-7.35	H	1.0	1.0
1	99.84	-68.48	-13.0	55.48	-12.49	H	188.2	1.0
1	184.23	-49.77	-13.0	36.77	-7.35	H	188.2	1.0
1	272.015	-58.0	-13.0	45.0	-1.48	H	92.5	1.0
1	499.48	-63.85	-13.0	50.85	-0.57	H	2.6	2.0

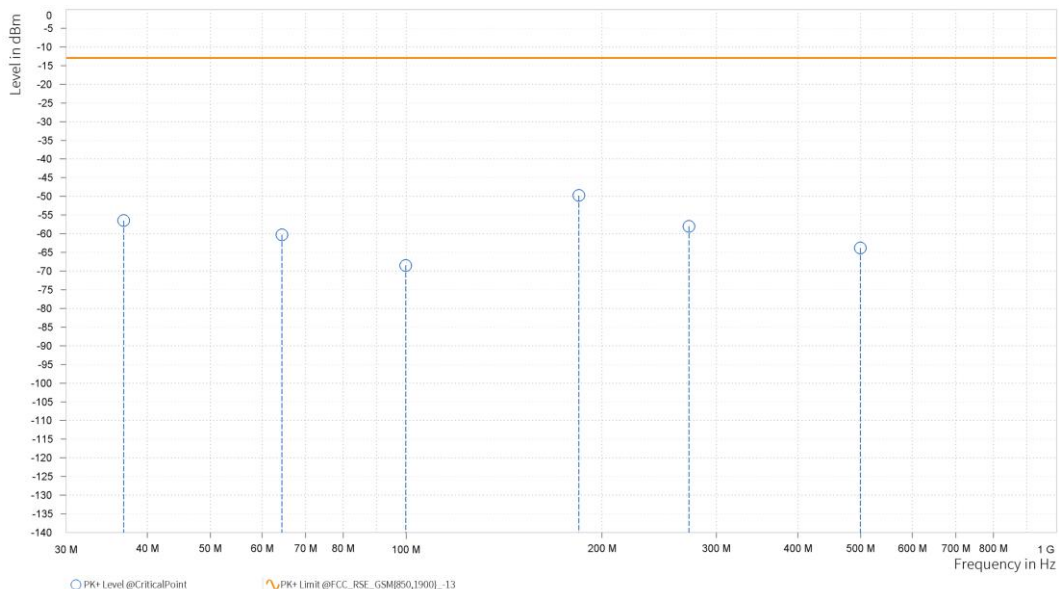



**BUREAU
VERITAS**

Test Report No.: PSU-NQN2406210109RF01

MODE	TX channel 20525	FREQUENCY RANGE	Below 1000MHz
ENVIRONMENTAL CONDITIONS	23deg. C, 70%RH	INPUT POWER	120Vac 60HZ
TESTED BY	Hanwen Xu		

ANTENNA POLARITY & TEST DISTANCE: VERTICAL AT 3 M

Rg	Frequency [MHz]	PK+ Level [dBm]	PK+ Limit [dBm]	PK+ Margin [dB]	Correction [dB]	Polarization	Azimuth [deg]	Antenna Height [m]
1	32.91	-57.02	-13.0	44.02	-8.13	V	358.2	1.0
1	58.13	-57.58	-13.0	44.58	-4.86	V	196.6	1.0
1	98.385	-41.23	-13.0	28.23	3.65	V	293.4	1.0
1	181.805	-62.36	-13.0	49.36	-9.68	V	4.9	1.0
1	276.865	-65.45	-13.0	52.45	-2.09	V	173.0	2.0
1	437.885	-63.69	-13.0	50.69	2.14	V	92.5	1.0

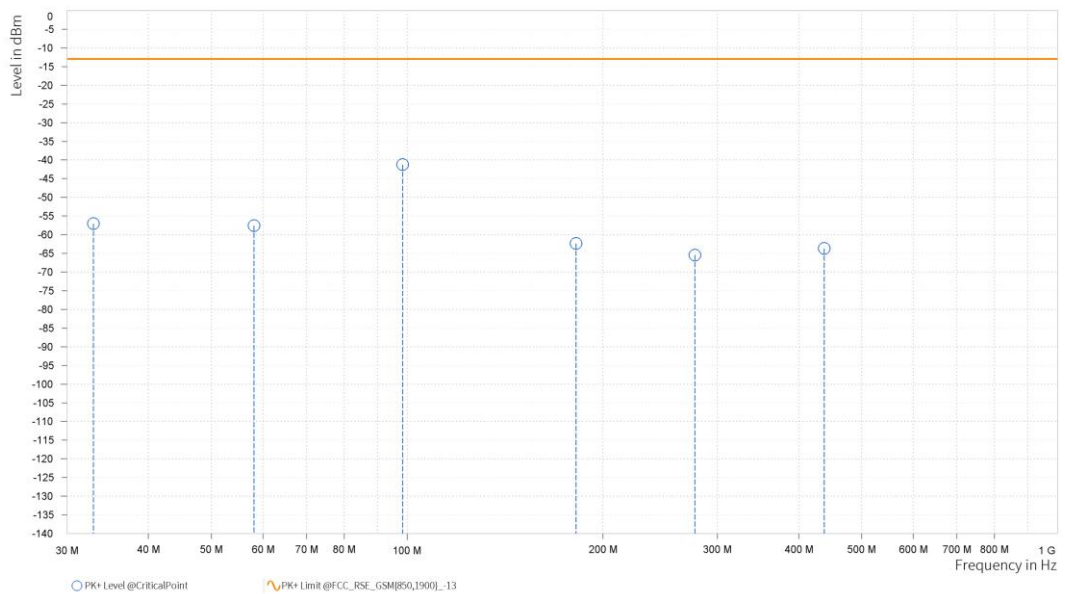



**BUREAU
VERITAS**

Test Report No.: PSU-NQN2406210109RF01

ABOVE 1GHz DATA

Note: For higher frequency, the emission is too low to be detected.

GSM 850

CH 128:

MODE	TX channel 128	FREQUENCY RANGE	Above 1000MHz
ENVIRONMENTAL CONDITIONS	23deg. C, 70%RH	INPUT POWER	120Vac 60HZ
TESTED BY	Hanwen Xu		

ANTENNA POLARITY & TEST DISTANCE: HORIZONTAL AT 3 M

Rg	Frequency [MHz]	PK+ Level [dBm]	PK+ Limit [dBm]	PK+ Margin [dB]	Correction [dB]	Polarization	Azimuth [deg]	Antenna Height [m]
2	1,648.500	-37.39	-13.0	24.39	15.93	H	272.2	2.0
3	2,472.600	-48.31	-13.0	35.31	20.69	H	161.8	1.0

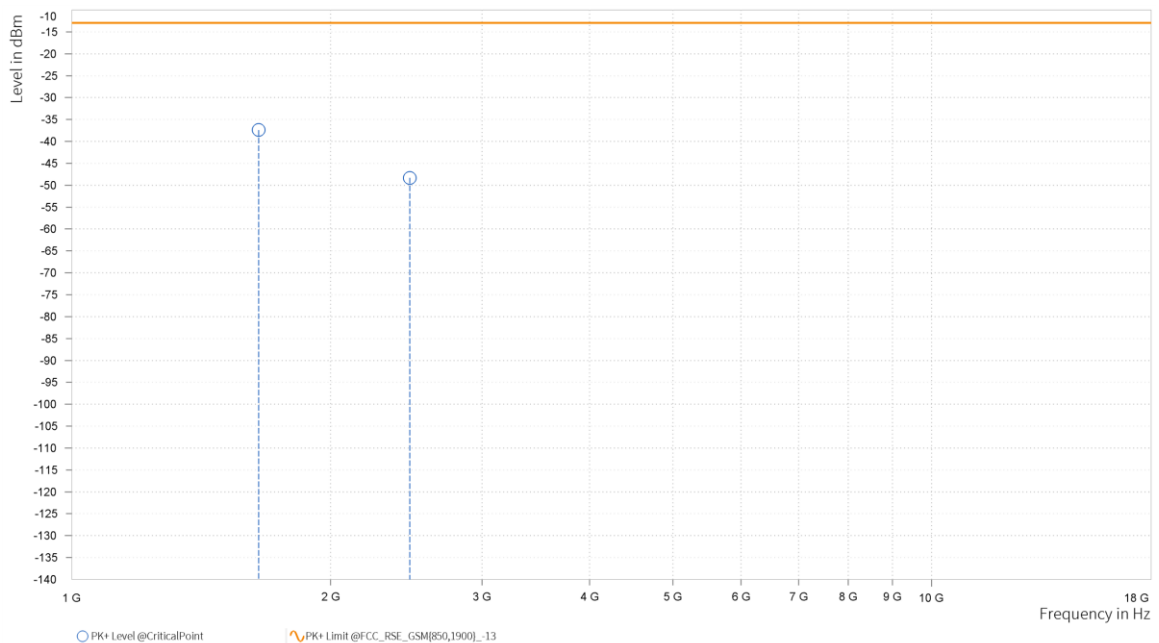



BUREAU VERITAS

Test Report No.: PSU-NQN2406210109RF01

MODE	TX channel 128	FREQUENCY RANGE	Above 1000MHz
ENVIRONMENTAL CONDITIONS	23deg. C, 70%RH	INPUT POWER	120Vac 60HZ
TESTED BY	Hanwen Xu		

ANTENNA POLARITY & TEST DISTANCE: VERTICAL AT 3 M

Rg	Frequency [MHz]	PK+ Level [dBm]	PK+ Limit [dBm]	PK+ Margin [dB]	Correction [dB]	Polarization	Azimuth [deg]	Antenna Height [m]
2	1,648.000	-36.69	-13.0	23.69	15.51	V	271.1	2.0
3	2,472.600	-45.4	-13.0	32.4	20.95	V	197.0	2.0

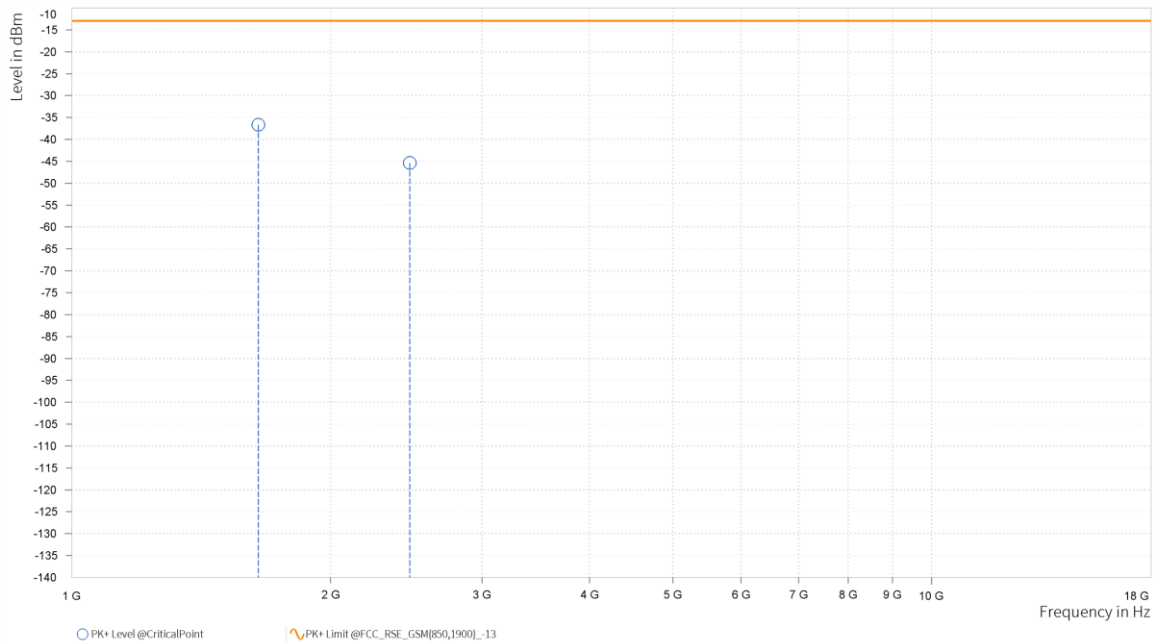



CH 189:

MODE	TX channel 189	FREQUENCY RANGE	Above 1000MHz
ENVIRONMENTAL CONDITIONS	23deg. C, 70%RH	INPUT POWER	120Vac 60HZ
TESTED BY	Hanwen Xu		

ANTENNA POLARITY & TEST DISTANCE: HORIZONTAL AT 3 M

Rg	Frequency [MHz]	PK+ Level [dBm]	PK+ Limit [dBm]	PK+ Margin [dB]	Correction [dB]	Polarization	Azimuth [deg]	Antenna Height [m]
2	1,672.000	-42.77	-13.0	29.77	16.67	H	89	1.0
3	2,509.000	-49.06	-13.0	36.06	21.0	H	1	1.0

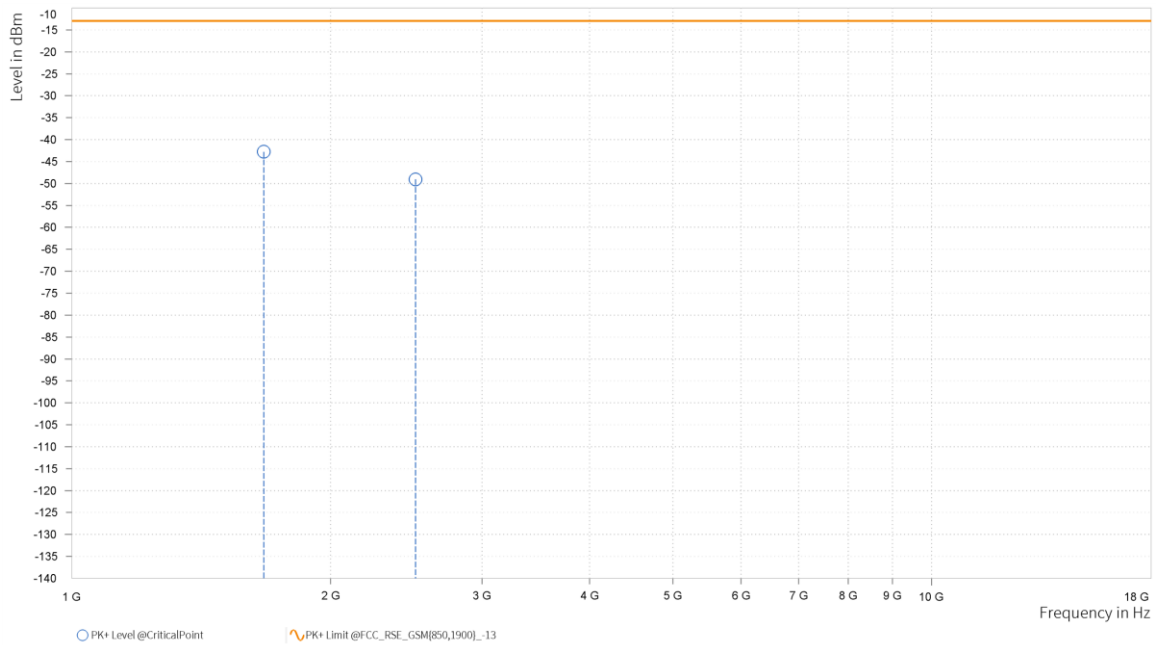



**BUREAU
VERITAS**

Test Report No.: PSU-NQN2406210109RF01

MODE	TX channel 189	FREQUENCY RANGE	Above 1000MHz
ENVIRONMENTAL CONDITIONS	23deg. C, 70%RH	INPUT POWER	120Vac 60HZ
TESTED BY	Hanwen Xu		

ANTENNA POLARITY & TEST DISTANCE: VERTICAL AT 3 M

Rg	Frequency [MHz]	PK+ Level [dBm]	PK+ Limit [dBm]	PK+ Margin [dB]	Correction [dB]	Polarization	Azimuth [deg]	Antenna Height [m]
2	1,672.500	-35.41	-13.0	22.41	15.57	V	271.1	2.0
3	2,509.000	-49.32	-13.0	36.32	21.61	V	0.9	2.0

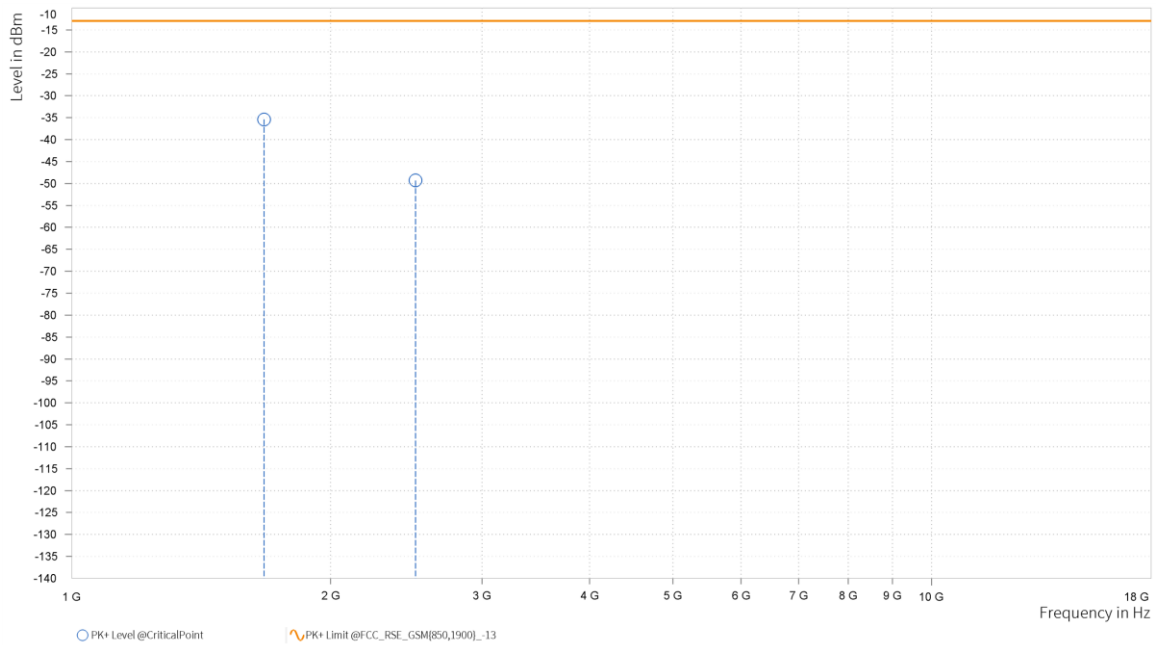



**BUREAU
VERITAS**

Test Report No.: PSU-NQN2406210109RF01

CH 251:

MODE	TX channel 251	FREQUENCY RANGE	Above 1000MHz
ENVIRONMENTAL CONDITIONS	23deg. C, 70%RH	INPUT POWER	120Vac 60HZ
TESTED BY	Hanwen Xu		

ANTENNA POLARITY & TEST DISTANCE: HORIZONTAL AT 3 M

Rg	Frequency [MHz]	PK+ Level [dBm]	PK+ Limit [dBm]	PK+ Margin [dB]	Correction [dB]	Polarization	Azimuth [deg]	Antenna Height [m]
2	1,697.000	-38.26	-13.0	25.26	17.08	H	271.1	2.0
3	2,546.000	-48.59	-13.0	35.59	20.93	H	1.0	2.0

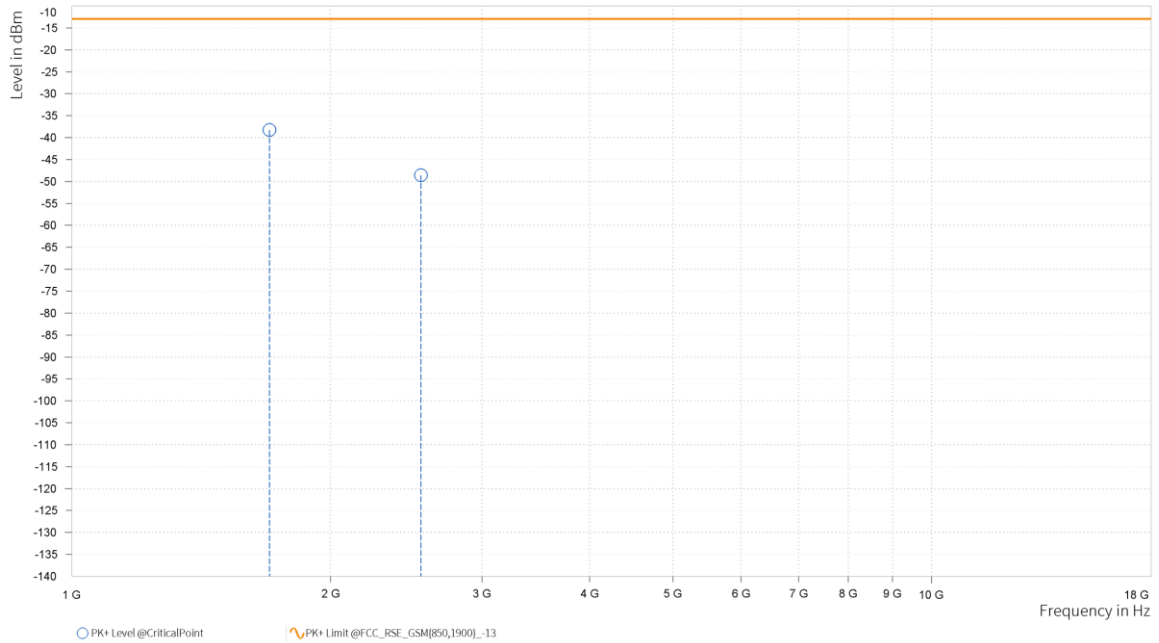



**BUREAU
VERITAS**

Test Report No.: PSU-NQN2406210109RF01

MODE	TX channel 251	FREQUENCY RANGE	Above 1000MHz
ENVIRONMENTAL CONDITIONS	23deg. C, 70%RH	INPUT POWER	120Vac 60HZ
TESTED BY	Hanwen Xu		

ANTENNA POLARITY & TEST DISTANCE: VERTICAL AT 3 M

Rg	Frequency [MHz]	PK+ Level [dBm]	PK+ Limit [dBm]	PK+ Margin [dB]	Correction [dB]	Polarization	Azimuth [deg]	Antenna Height [m]
2	1,697.000	-37.22	-13.0	24.22	16.28	V	272.3	2.0
3	2,546.000	-48.63	-13.0	35.63	21.56	V	1.0	1.0

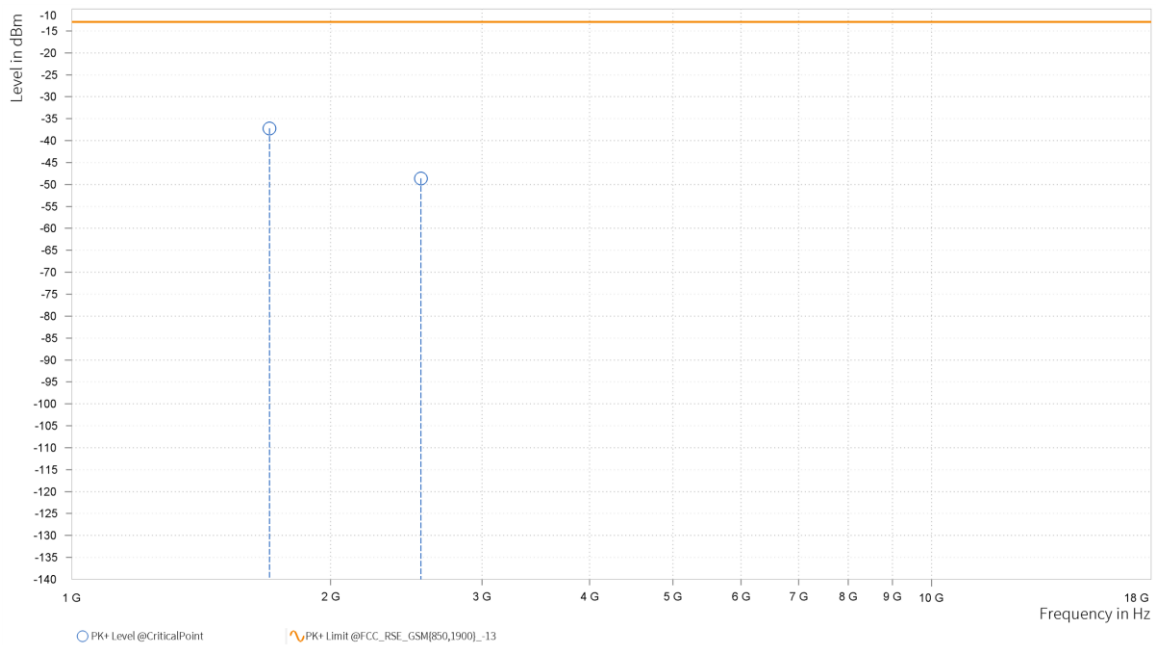



BUREAU VERITAS

Test Report No.: PSU-NQN2406210109RF01

EDGE 850:

CH 128:

MODE	TX channel 128	FREQUENCY RANGE	Above 1000MHz
ENVIRONMENTAL CONDITIONS	23deg. C, 70%RH	INPUT POWER	120Vac 60HZ
TESTED BY	Hanwen Xu		

ANTENNA POLARITY & TEST DISTANCE: HORIZONTAL AT 3 M

Rg	Frequency [MHz]	PK+ Level [dBm]	PK+ Limit [dBm]	PK+ Margin [dB]	Correction [dB]	Polarization	Azimuth [deg]	Antenna Height [m]
2	1,648.000	-43.78	-13.0	30.78	15.9	H	0.9	2.0
3	2,472.500	-45.1	-13.0	32.1	20.69	H	0.9	2.0

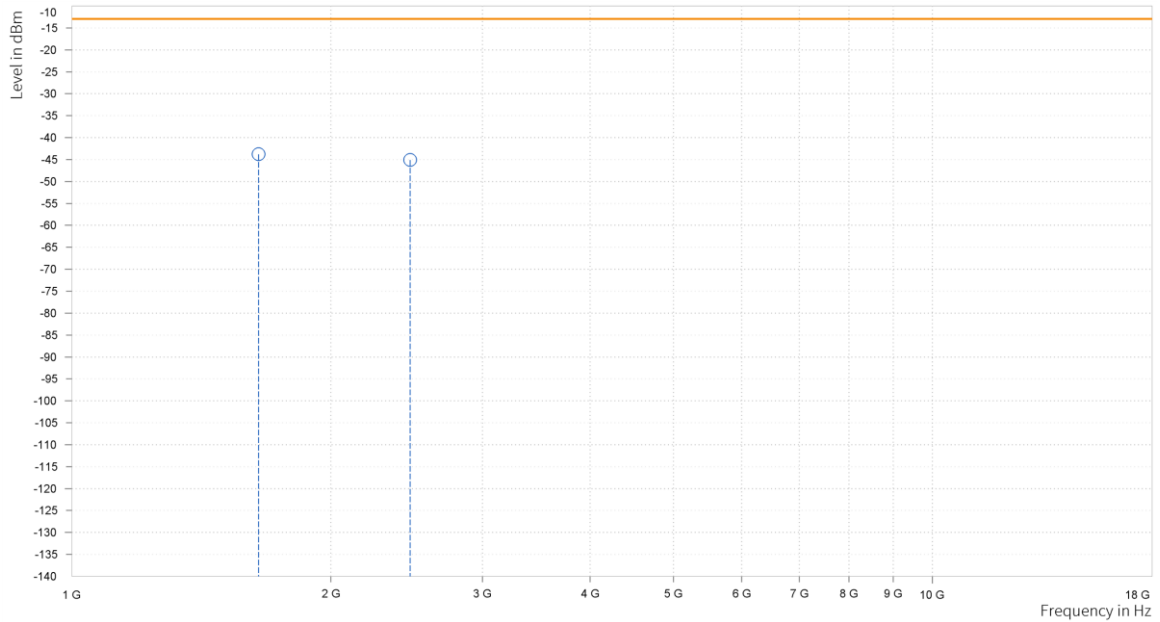



**BUREAU
VERITAS**

Test Report No.: PSU-NQN2406210109RF01

MODE	TX channel 128	FREQUENCY RANGE	Above 1000MHz
ENVIRONMENTAL CONDITIONS	23deg. C, 70%RH	INPUT POWER	120Vac 60HZ
TESTED BY	Hanwen Xu		

ANTENNA POLARITY & TEST DISTANCE: VERTICAL AT 3 M

Rg	Frequency [MHz]	PK+ Level [dBm]	PK+ Limit [dBm]	PK+ Margin [dB]	Correction [dB]	Polarization	Azimuth [deg]	Antenna Height [m]
2	1,649.500	-42.77	-13.0	29.77	15.5	V	271	2.0
3	2,473.000	-44.53	-13.0	31.53	20.95	V	359	2.0

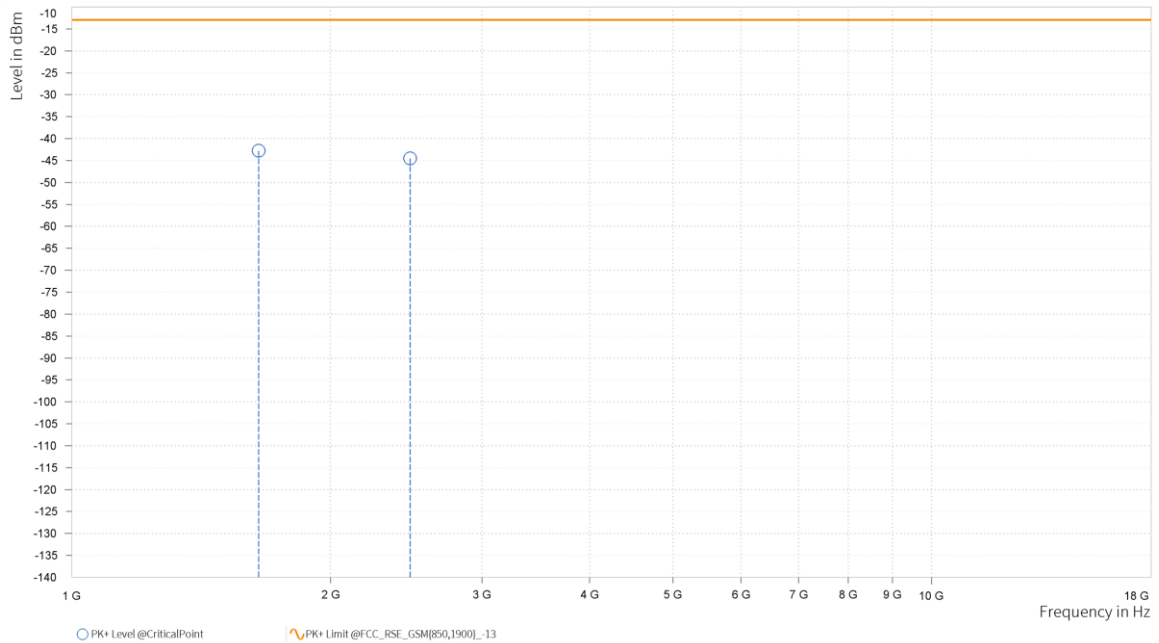



**BUREAU
VERITAS**

Test Report No.: PSU-NQN2406210109RF01

CH 189:

MODE	TX channel 189	FREQUENCY RANGE	Above 1000MHz
ENVIRONMENTAL CONDITIONS	23deg. C, 70%RH	INPUT POWER	120Vac 60HZ
TESTED BY	Hanwen Xu		

ANTENNA POLARITY & TEST DISTANCE: HORIZONTAL AT 3 M

Rg	Frequency [MHz]	PK+ Level [dBm]	PK+ Limit [dBm]	PK+ Margin [dB]	Correction [dB]	Polarization	Azimuth [deg]	Antenna Height [m]
2	1,672.000	-41.15	-13.0	28.15	16.67	H	272.2	2.0
3	2,509.000	-47.02	-13.0	34.02	21.0	H	1.0	1.0

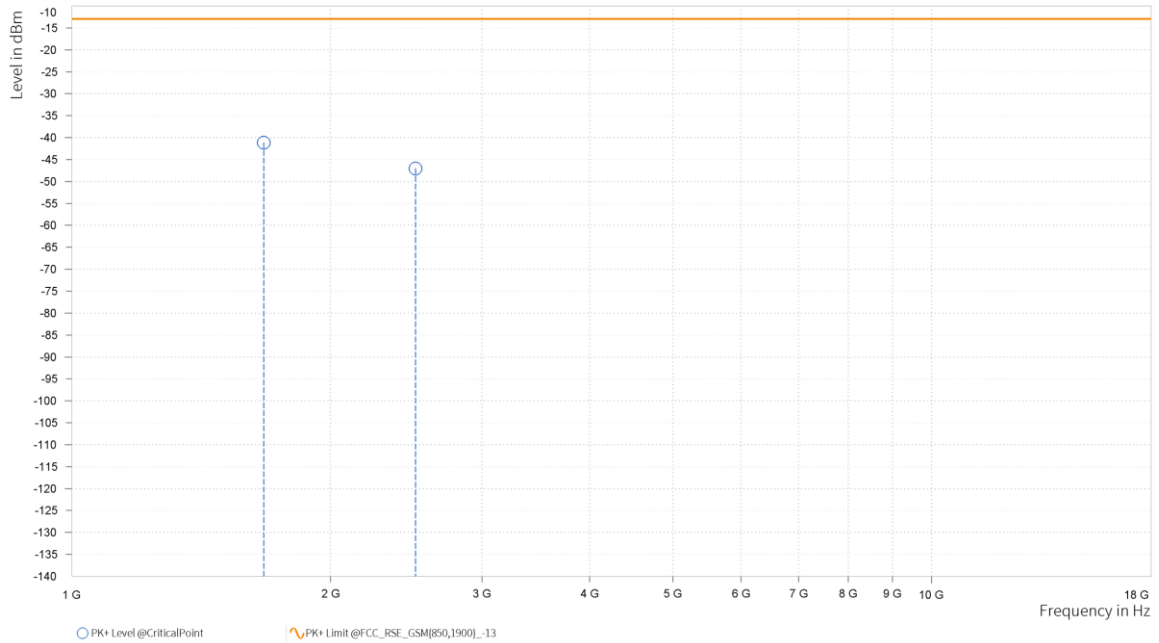



**BUREAU
VERITAS**

Test Report No.: PSU-NQN2406210109RF01

MODE	TX channel 189	FREQUENCY RANGE	Above 1000MHz
ENVIRONMENTAL CONDITIONS	23deg. C, 70%RH	INPUT POWER	120Vac 60HZ
TESTED BY	Hanwen Xu		

ANTENNA POLARITY & TEST DISTANCE: VERTICAL AT 3 M

Rg	Frequency [MHz]	PK+ Level [dBm]	PK+ Limit [dBm]	PK+ Margin [dB]	Correction [dB]	Polarization	Azimuth [deg]	Antenna Height [m]
2	1,673.000	-36.21	-13.0	23.21	15.57	V	271	2.0
3	2,509.000	-46.75	-13.0	33.75	21.61	V	359	2.0

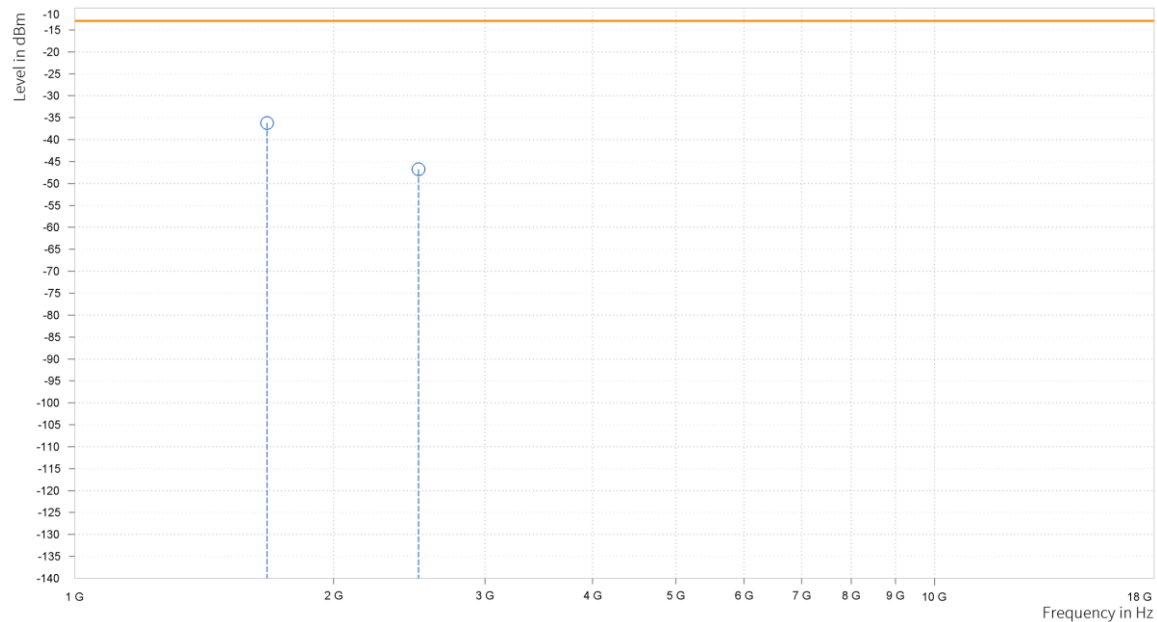



CH 251:

MODE	TX channel 251	FREQUENCY RANGE	Above 1000MHz
ENVIRONMENTAL CONDITIONS	23deg. C, 70%RH	INPUT POWER	120Vac 60HZ
TESTED BY	Hanwen Xu		

ANTENNA POLARITY & TEST DISTANCE: HORIZONTAL AT 3 M

Rg	Frequency [MHz]	PK+ Level [dBm]	PK+ Limit [dBm]	PK+ Margin [dB]	Correction [dB]	Polarization	Azimuth [deg]	Antenna Height [m]
2	1,698.500	-42.16	-13.0	29.16	17.06	H	271.1	2.0
3	2,546.000	-46.63	-13.0	33.63	20.93	H	198.2	2.0

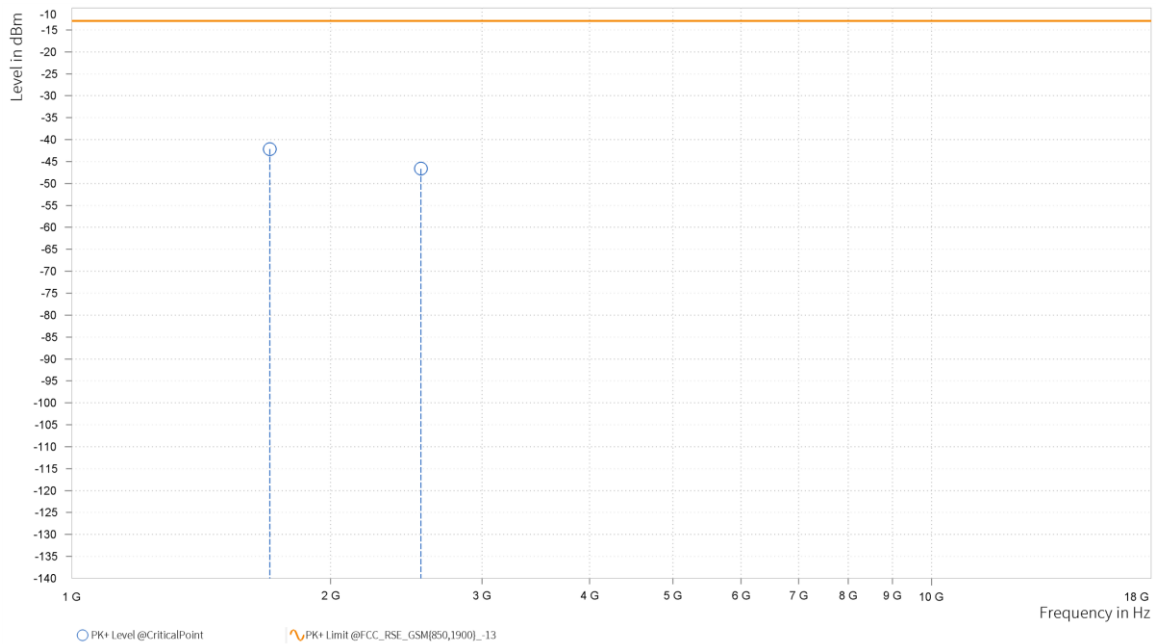



BUREAU VERITAS

Test Report No.: PSU-NQN2406210109RF01

MODE	TX channel 251	FREQUENCY RANGE	Above 1000MHz
ENVIRONMENTAL CONDITIONS	23deg. C, 70%RH	INPUT POWER	120Vac 60HZ
TESTED BY	Hanwen Xu		

ANTENNA POLARITY & TEST DISTANCE: VERTICAL AT 3 M

Rg	Frequency [MHz]	PK+ Level [dBm]	PK+ Limit [dBm]	PK+ Margin [dB]	Correction [dB]	Polarization	Azimuth [deg]	Antenna Height [m]
2	1,696.500	-46.35	-13.0	33.35	16.26	V	272.2	2.0
3	2,546.000	-48.27	-13.0	35.27	21.56	V	359.0	2.0

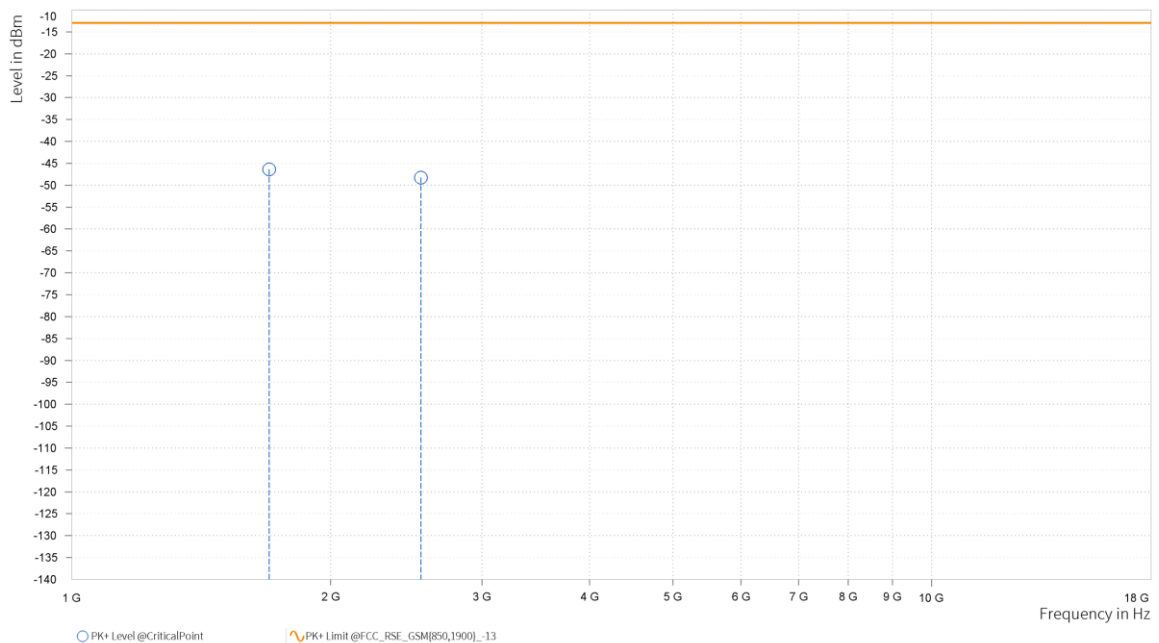



CDMA2000 BC0:

CH 1013

MODE	TX channel 1013	FREQUENCY RANGE	Above 1000MHz
ENVIRONMENTAL CONDITIONS	23deg. C, 70%RH	INPUT POWER	120Vac 60HZ
TESTED BY	Jace Hu		
ANTENNA POLARITY & TEST DISTANCE: HORIZONTAL AT 3 M			

	Freq	Level	Read Level	Limit Line	Over Limit	Factor	Remark	Pol/Phase
	MHz	dBm/m	dBm	dBm/m	dB	dB/m		
1	1648.000	-55.65	-59.31	-13.00	-42.65	3.66	Peak	Horizontal
2 PP	2480.000	-46.84	-52.89	-13.00	-33.84	6.05	Peak	Horizontal

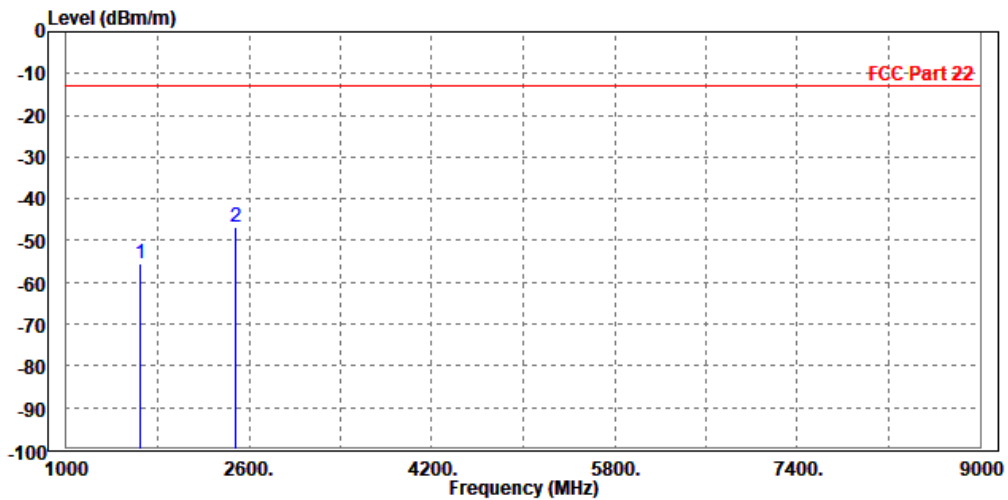



MODE	TX channel 1013	FREQUENCY RANGE	Above 1000MHz
ENVIRONMENTAL CONDITIONS	23deg. C, 70%RH	INPUT POWER	120Vac 60HZ
TESTED BY	Jace Hu		
ANTENNA POLARITY & TEST DISTANCE: VERTICAL AT 3 M			

	Freq	Level	Read Level	Limit Line	Over Limit	Factor	Remark	Pol/Phase
	MHz	dBm/m	dBm	dBm/m	dB	dB/m		
1 PP	1649.400	-53.46	-56.85	-13.00	-40.46	3.39	Peak	Vertical
2	2472.000	-53.64	-59.32	-13.00	-40.64	5.68	Peak	Vertical

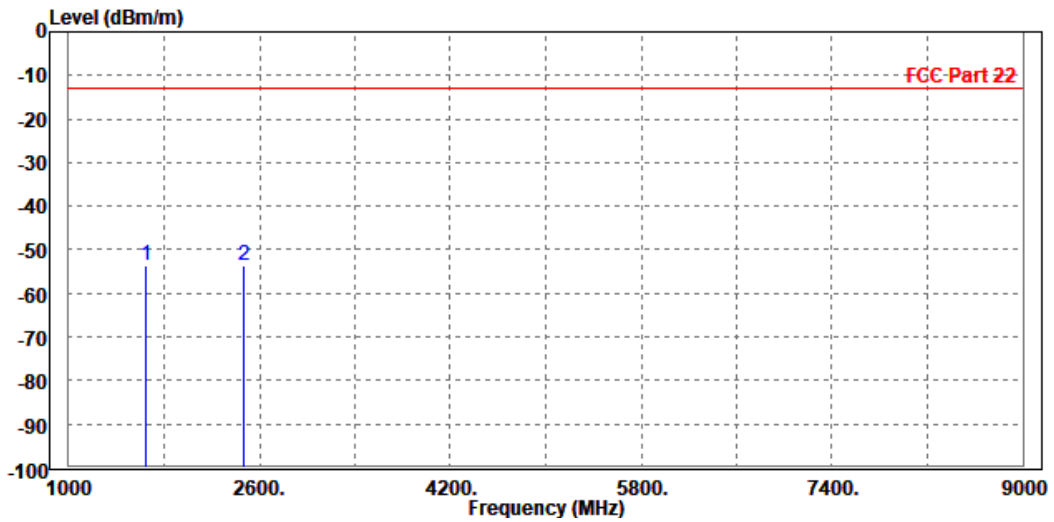



CH 384

MODE	TX channel 384	FREQUENCY RANGE	Above 1000MHz
ENVIRONMENTAL CONDITIONS	23deg. C, 70%RH	INPUT POWER	120Vac 60HZ
TESTED BY	Jace Hu		
ANTENNA POLARITY & TEST DISTANCE: HORIZONTAL AT 3 M			

	Freq	Level	Read Level	Limit Line	Over Limit	Factor	Remark	Pol/Phase
	MHz	dBm/m	dBm	dBm/m	dB	dB/m		
1	PP 1673.000	-46.00	-49.74	-13.00	-33.00	3.74	Peak	Horizontal
2	2512.000	-53.65	-59.80	-13.00	-40.65	6.15	Peak	Horizontal

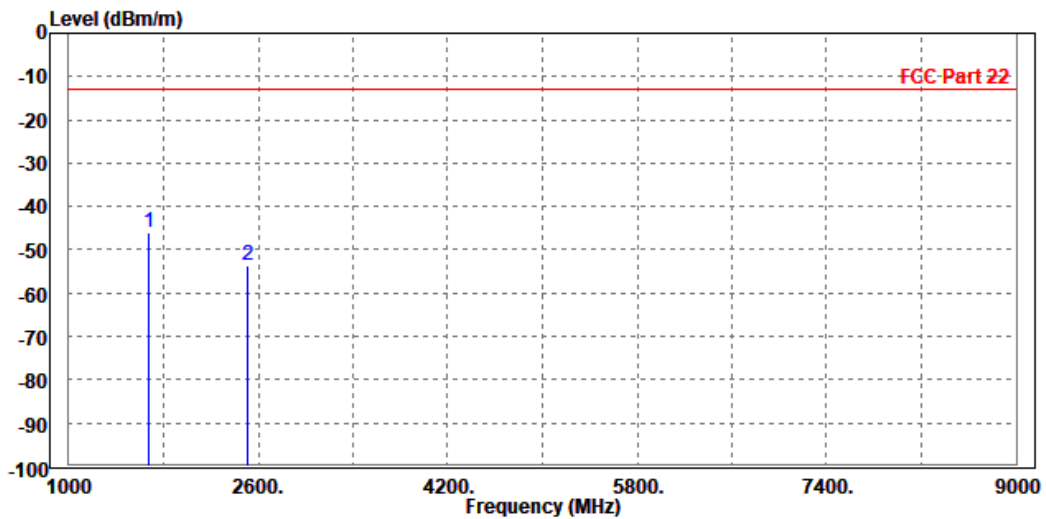



**BUREAU
VERITAS**

Test Report No.: PSU-NQN2406210109RF01

MODE	TX channel 384	FREQUENCY RANGE	Above 1000MHz
ENVIRONMENTAL CONDITIONS	23deg. C, 70%RH	INPUT POWER	120Vac 60HZ
TESTED BY	Jace Hu		
ANTENNA POLARITY & TEST DISTANCE: VERTICAL AT 3 M			

	Freq	Level	Read Level	Limit Line	Over Limit	Factor	Remark	Pol/Phase
	MHz	dBm/m	dBm	dBm/m	dB	dB/m		
1	PP 1672.000	-44.38	-47.81	-13.00	-31.38	3.43	Peak	Vertical
2	2509.500	-53.49	-59.33	-13.00	-40.49	5.84	Peak	Vertical

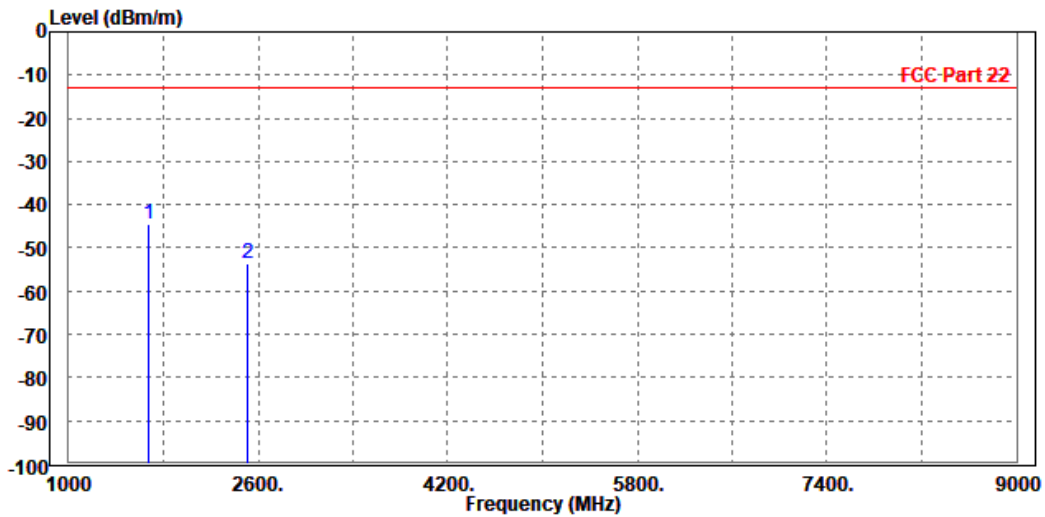



CH 777

MODE	TX channel 777	FREQUENCY RANGE	Above 1000MHz
ENVIRONMENTAL CONDITIONS	23deg. C, 70%RH	INPUT POWER	120Vac 60HZ
TESTED BY	Jace Hu		
ANTENNA POLARITY & TEST DISTANCE: HORIZONTAL AT 3 M			

	Freq	Level	Read Level	Limit Line	Over Limit	Factor	Remark	Pol/Phase
	MHz	dBm/m	dBm	dBm/m	dB	dB/m		
1	1696.600	-55.48	-59.29	-13.00	-42.48	3.81	Peak	Horizontal
2 PP	2544.000	-53.53	-59.82	-13.00	-40.53	6.29	Peak	Horizontal

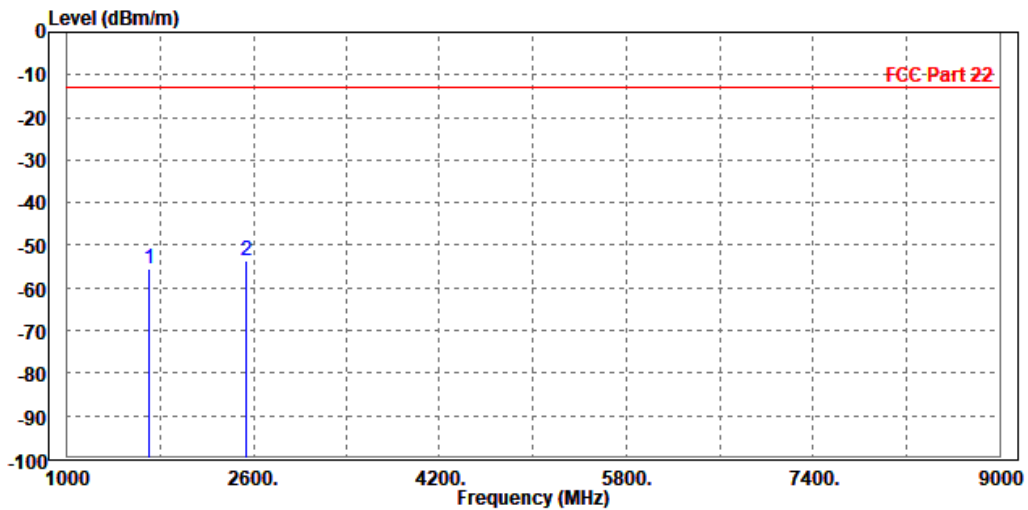



MODE	TX channel 777	FREQUENCY RANGE	Above 1000MHz
ENVIRONMENTAL CONDITIONS	23deg. C, 70%RH	INPUT POWER	120Vac 60HZ
TESTED BY	Jace Hu		
ANTENNA POLARITY & TEST DISTANCE: VERTICAL AT 3 M			

	Freq	Level	Read Level	Limit Line	Over Limit	Factor	Remark	Pol/Phase
	MHz	dBm/m	dBm	dBm/m	dB	dB/m		
1	1696.000	-54.05	-57.52	-13.00	-41.05	3.47	Peak	Vertical
2	PP 2544.900	-53.26	-59.31	-13.00	-40.26	6.05	Peak	Vertical

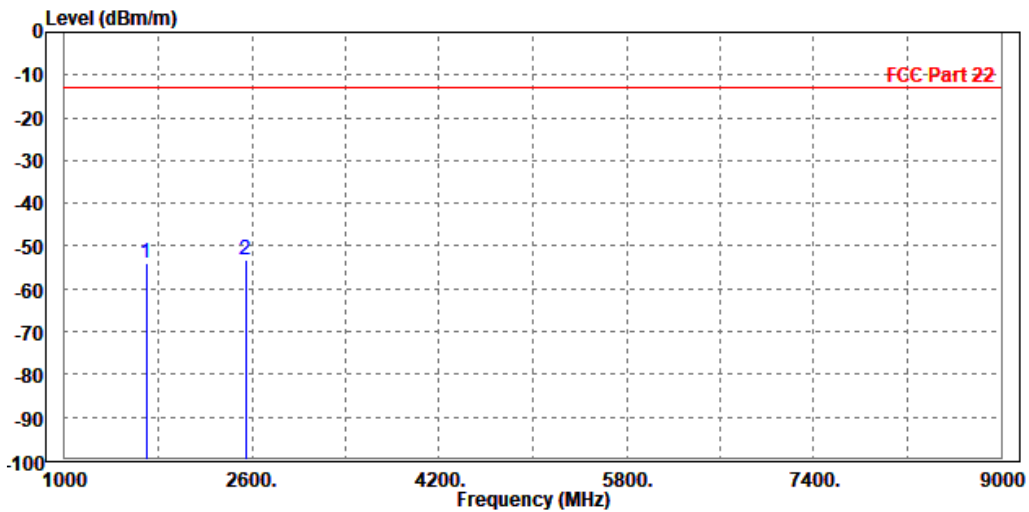



WCDMA Band V:

CH 4132:

MODE	TX channel 4132	FREQUENCY RANGE	Above 1000MHz
ENVIRONMENTAL CONDITIONS	23deg. C, 70%RH	INPUT POWER	120Vac 60HZ
TESTED BY	Hanwen Xu		

ANTENNA POLARITY & TEST DISTANCE: HORIZONTAL AT 3 M

Rg	Frequency [MHz]	PK+ Level [dBm]	PK+ Limit [dBm]	PK+ Margin [dB]	Correction [dB]	Polarization	Azimuth [deg]	Antenna Height [m]
2	1,654.500	-42.69	-13.0	29.69	14.36	H	176.1	2.0
3	2,479.000	-51.38	-13.0	38.38	19.47	H	359.0	2.0

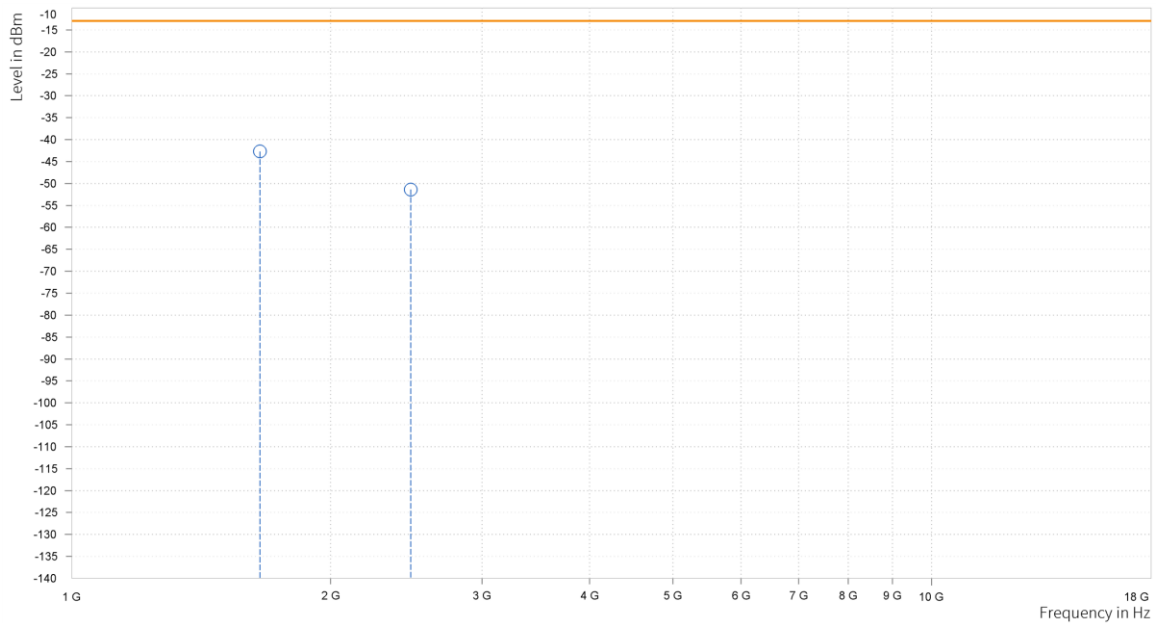



**BUREAU
VERITAS**

Test Report No.: PSU-NQN2406210109RF01

MODE	TX channel 4132	FREQUENCY RANGE	Above 1000MHz
ENVIRONMENTAL CONDITIONS	23deg. C, 70%RH	INPUT POWER	120Vac 60HZ
TESTED BY	Hanwen Xu		

ANTENNA POLARITY & TEST DISTANCE: VERTICAL AT 3 M

Rg	Frequency [MHz]	PK+ Level [dBm]	PK+ Limit [dBm]	PK+ Margin [dB]	Correction [dB]	Polarization	Azimuth [deg]	Antenna Height [m]
2	1,655.000	-47.39	-13.0	34.39	13.55	V	176.1	2.0
3	2,479.000	-50.86	-13.0	37.86	19.71	V	297.0	2.0

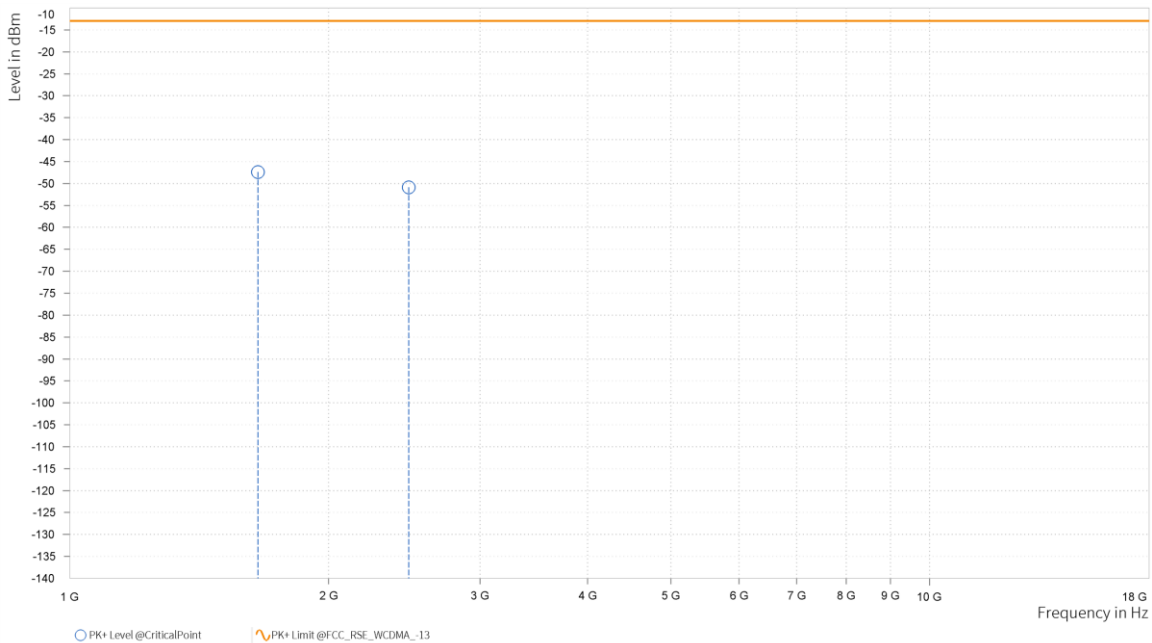



**BUREAU
VERITAS**

Test Report No.: PSU-NQN2406210109RF01

CH 4182:

MODE	TX channel 4182	FREQUENCY RANGE	Above 1000MHz
ENVIRONMENTAL CONDITIONS	23deg. C, 70%RH	INPUT POWER	120Vac 60HZ
TESTED BY	Hanwen Xu		

ANTENNA POLARITY & TEST DISTANCE: HORIZONTAL AT 3 M

Rg	Frequency [MHz]	PK+ Level [dBm]	PK+ Limit [dBm]	PK+ Margin [dB]	Correction [dB]	Polarization	Azimuth [deg]	Antenna Height [m]
2	1,674.500	-41.38	-13.0	28.38	14.81	H	176.1	2.0
3	2,509.200	-51.09	-13.0	38.09	19.71	H	169.0	2.0

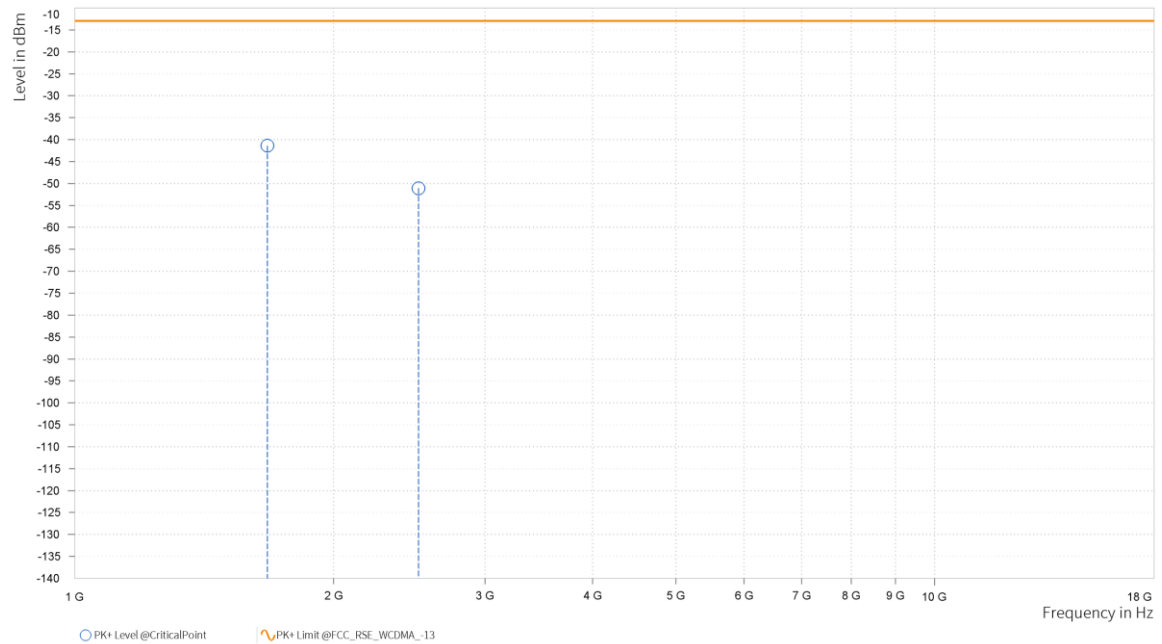



MODE	TX channel 4182	FREQUENCY RANGE	Above 1000MHz
ENVIRONMENTAL CONDITIONS	23deg. C, 70%RH	INPUT POWER	120Vac 60HZ
TESTED BY	Hanwen Xu		

ANTENNA POLARITY & TEST DISTANCE: VERTICAL AT 3 M

Rg	Frequency [MHz]	PK+ Level [dBm]	PK+ Limit [dBm]	PK+ Margin [dB]	Correction [dB]	Polarization	Azimuth [deg]	Antenna Height [m]
2	1,670.500	-45.63	-13.0	32.63	13.67	V	183.9	1.0
3	2,509.200	-49.47	-13.0	36.47	20.32	V	359.1	1.0

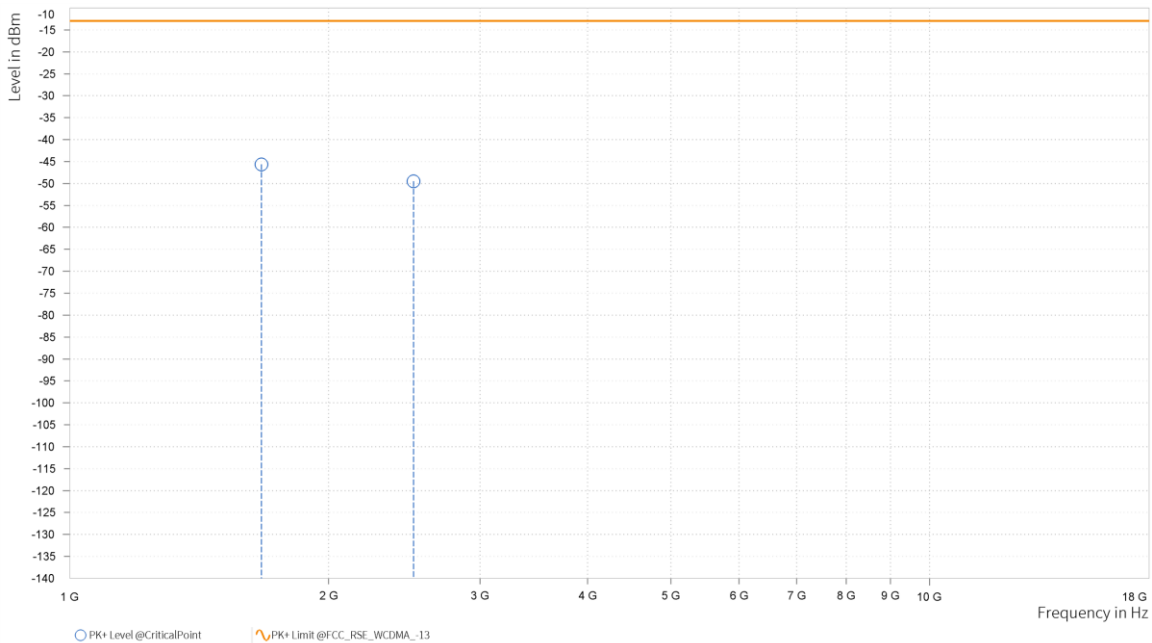



CH 4233:

MODE	TX channel 4233	FREQUENCY RANGE	Above 1000MHz
ENVIRONMENTAL CONDITIONS	23deg. C, 70%RH	INPUT POWER	120Vac 60HZ
TESTED BY	Hanwen Xu		

ANTENNA POLARITY & TEST DISTANCE: HORIZONTAL AT 3 M

Rg	Frequency [MHz]	PK+ Level [dBm]	PK+ Limit [dBm]	PK+ Margin [dB]	Correction [dB]	Polarization	Azimuth [deg]	Antenna Height [m]
2	1,691.500	-41.17	-13.0	28.17	15.12	H	176.1	2.0
3	2,539.500	-52.81	-13.0	39.81	19.37	H	296.4	2.0

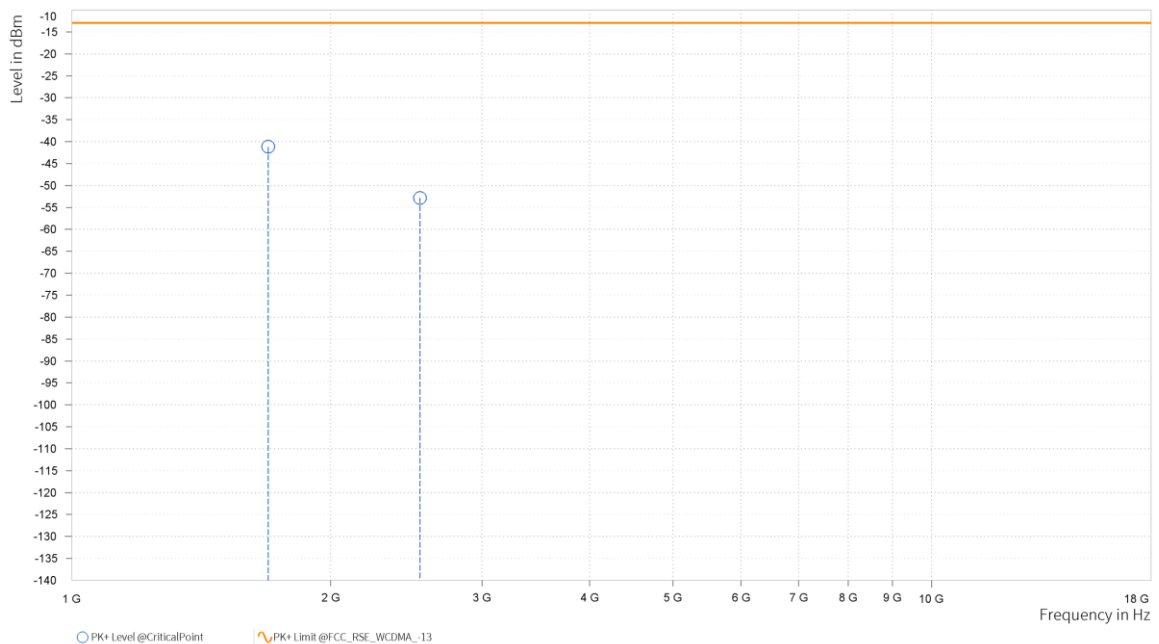



BUREAU VERITAS

Test Report No.: PSU-NQN2406210109RF01

MODE	TX channel 4233	FREQUENCY RANGE	Above 1000MHz
ENVIRONMENTAL CONDITIONS	23deg. C, 70%RH	INPUT POWER	120Vac 60HZ
TESTED BY	Hanwen Xu		

ANTENNA POLARITY & TEST DISTANCE: VERTICAL AT 3 M

Rg	Frequency [MHz]	PK+ Level [dBm]	PK+ Limit [dBm]	PK+ Margin [dB]	Correction [dB]	Polarization	Azimuth [deg]	Antenna Height [m]
2	1,691.500	-47.28	-13.0	34.28	14.13	V	176.1	2.0
3	2,539.500	-52.37	-13.0	39.37	20.06	V	296.4	2.0

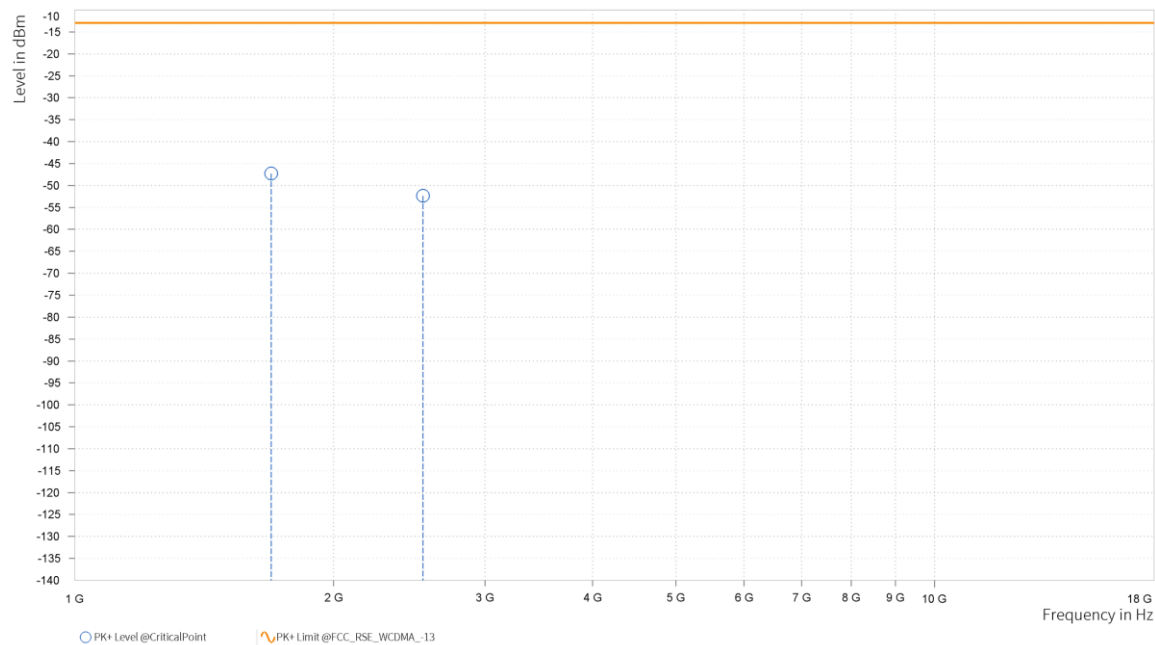



**BUREAU
VERITAS**

Test Report No.: PSU-NQN2406210109RF01

LTE Band 5

CHANNEL BANDWIDTH: 1.4MHz / QPSK

CH 20407

MODE	TX channel 20407	FREQUENCY RANGE	Above 1000MHz
ENVIRONMENTAL CONDITIONS	23deg. C, 70%RH	INPUT POWER	120Vac 60HZ
TESTED BY	Hanwen Xu		

ANTENNA POLARITY & TEST DISTANCE: HORIZONTAL AT 3 M

Rg	Frequency [MHz]	PK+ Level [dBm]	PK+ Limit [dBm]	PK+ Margin [dB]	Correction [dB]	Polarization	Azimuth [deg]	Antenna Height [m]
2	1,648.140	-44.45	-13.0	31.45	14.04	H	179.7	1.0
3	2,472.210	-50.41	-13.0	37.41	19.27	H	174.0	2.0

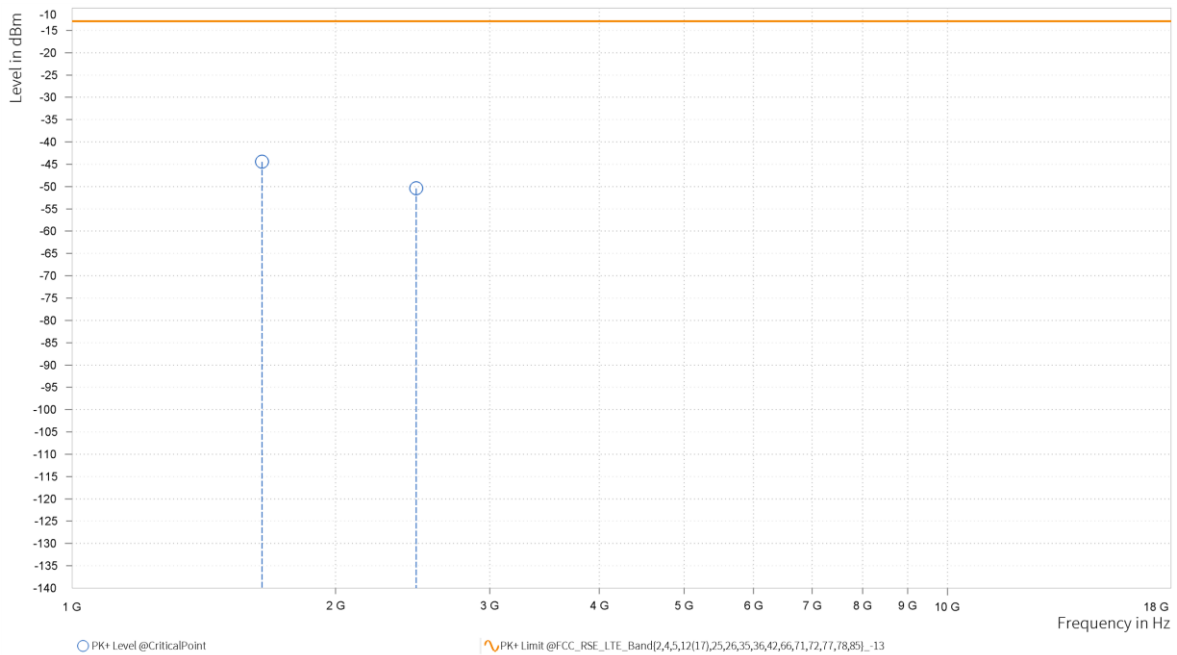



**BUREAU
VERITAS**

Test Report No.: PSU-NQN2406210109RF01

MODE	TX channel 20407	FREQUENCY RANGE	Above 1000MHz
ENVIRONMENTAL CONDITIONS	23deg. C, 70%RH	INPUT POWER	120Vac 60HZ
TESTED BY	Hanwen Xu		

ANTENNA POLARITY & TEST DISTANCE: VERTICAL AT 3 M

Rg	Frequency [MHz]	PK+ Level [dBm]	PK+ Limit [dBm]	PK+ Margin [dB]	Correction [dB]	Polarization	Azimuth [deg]	Antenna Height [m]
2	1,648.500	-43.83	-13.0	30.83	13.65	V	0.9	2.0
3	2,472.210	-51.05	-13.0	38.05	19.52	V	14.0	2.0

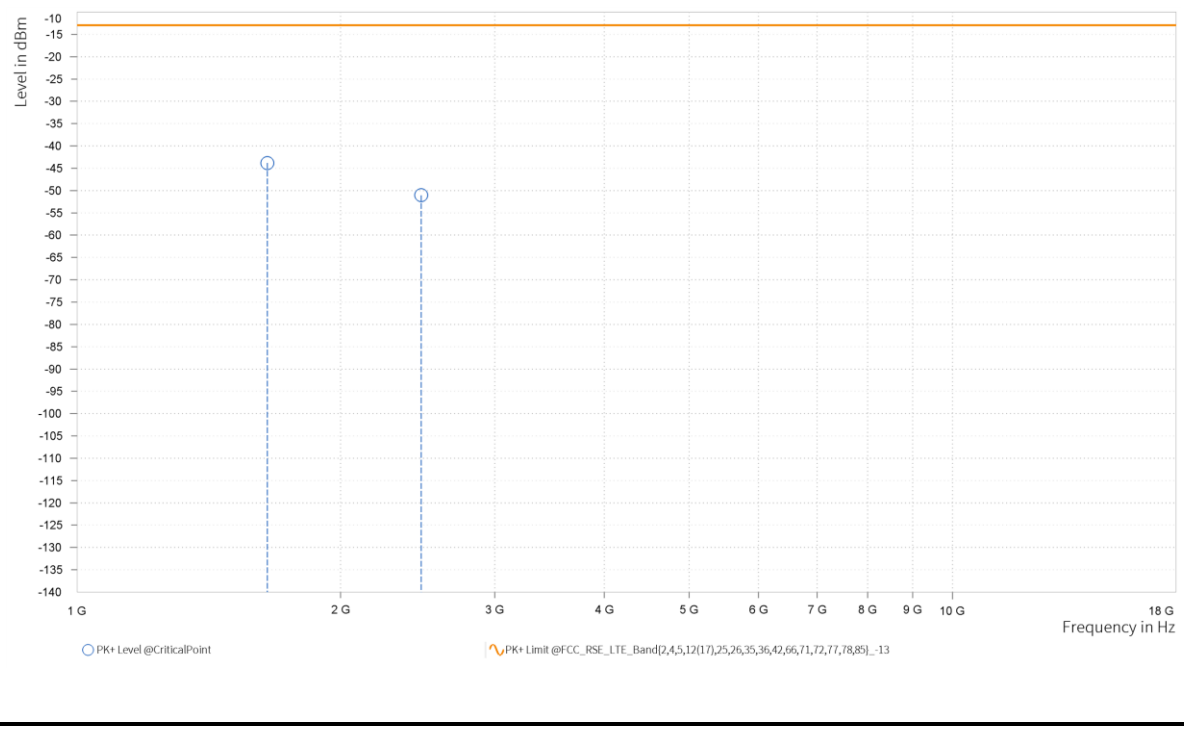



CH20525

MODE	TX channel 20525	FREQUENCY RANGE	Above 1000MHz
ENVIRONMENTAL CONDITIONS	23deg. C, 70%RH	INPUT POWER	120Vac 60HZ
TESTED BY	Hanwen Xu		

ANTENNA POLARITY & TEST DISTANCE: HORIZONTAL AT 3 M

Rg	Frequency [MHz]	PK+ Level [dBm]	PK+ Limit [dBm]	PK+ Margin [dB]	Correction [dB]	Polarization	Azimuth [deg]	Antenna Height [m]
2	1,672.500	-39.98	-13.0	26.98	14.8	H	176.1	1.0
3	2,507.610	-51.78	-13.0	38.78	19.73	H	123.0	2.0

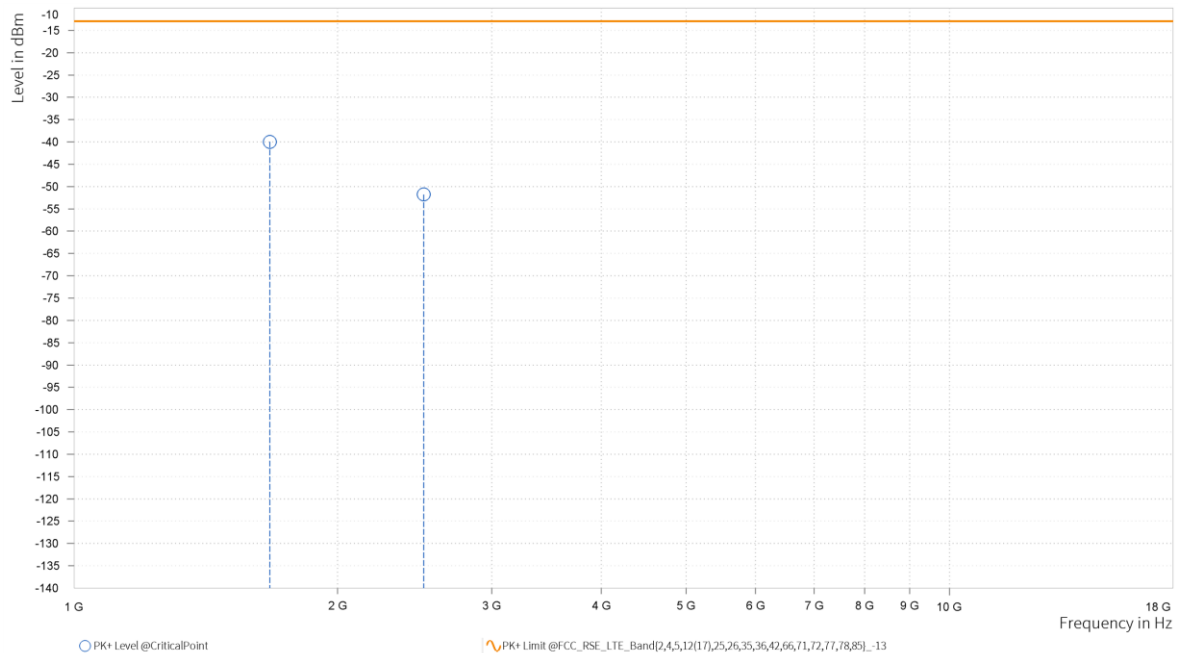



MODE	TX channel 20525	FREQUENCY RANGE	Above 1000MHz
ENVIRONMENTAL CONDITIONS	23deg. C, 70%RH	INPUT POWER	120Vac 60HZ
TESTED BY	Hanwen Xu		

ANTENNA POLARITY & TEST DISTANCE: VERTICAL AT 3 M

Rg	Frequency [MHz]	PK+ Level [dBm]	PK+ Limit [dBm]	PK+ Margin [dB]	Correction [dB]	Polarization	Azimuth [deg]	Antenna Height [m]
2	1,672.500	-41.8	-13.0	28.8	13.69	V	324.6	2.0
3	2,507.610	-50.58	-13.0	37.58	20.3	V	17.5	2.0

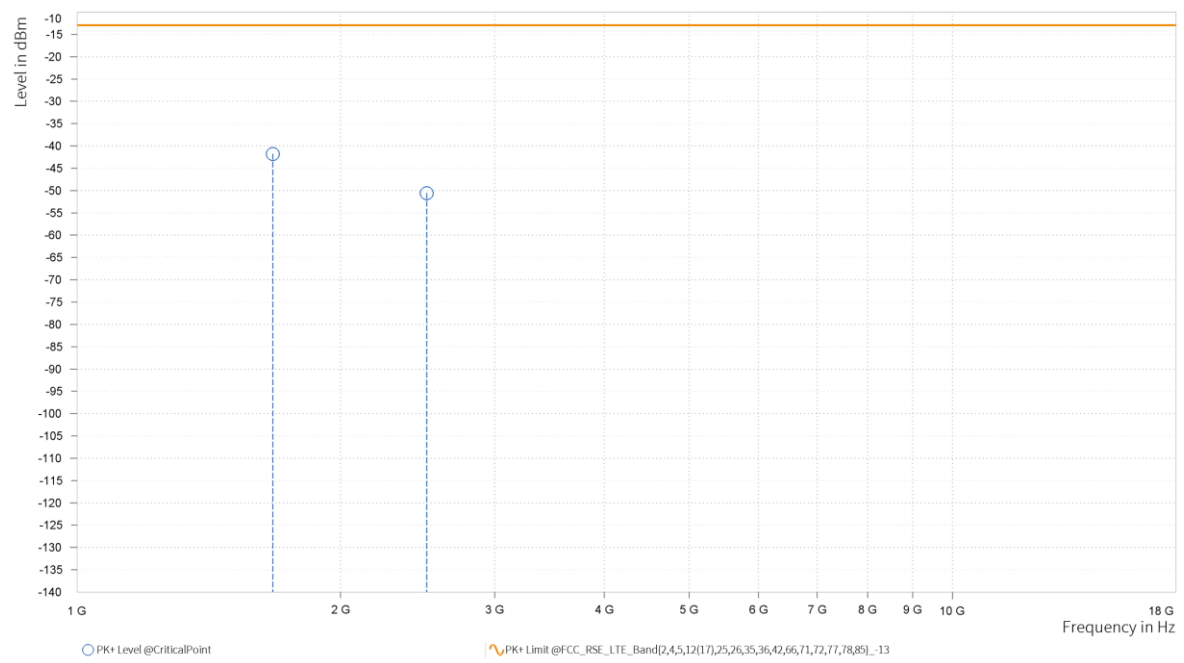



**BUREAU
VERITAS**

Test Report No.: PSU-NQN2406210109RF01

CH 20643

MODE	TX channel 20643	FREQUENCY RANGE	Above 1000MHz
ENVIRONMENTAL CONDITIONS	23deg. C, 70%RH	INPUT POWER	120Vac 60HZ
TESTED BY	Hanwen Xu		

ANTENNA POLARITY & TEST DISTANCE: HORIZONTAL AT 3 M

Rg	Frequency [MHz]	PK+ Level [dBm]	PK+ Limit [dBm]	PK+ Margin [dB]	Correction [dB]	Polarization	Azimuth [deg]	Antenna Height [m]
2	1,695.500	-42.86	-13.0	29.86	15.13	H	324.7	2.0
3	2,543.010	-52.1	-13.0	39.1	19.35	H	0.9	2.0

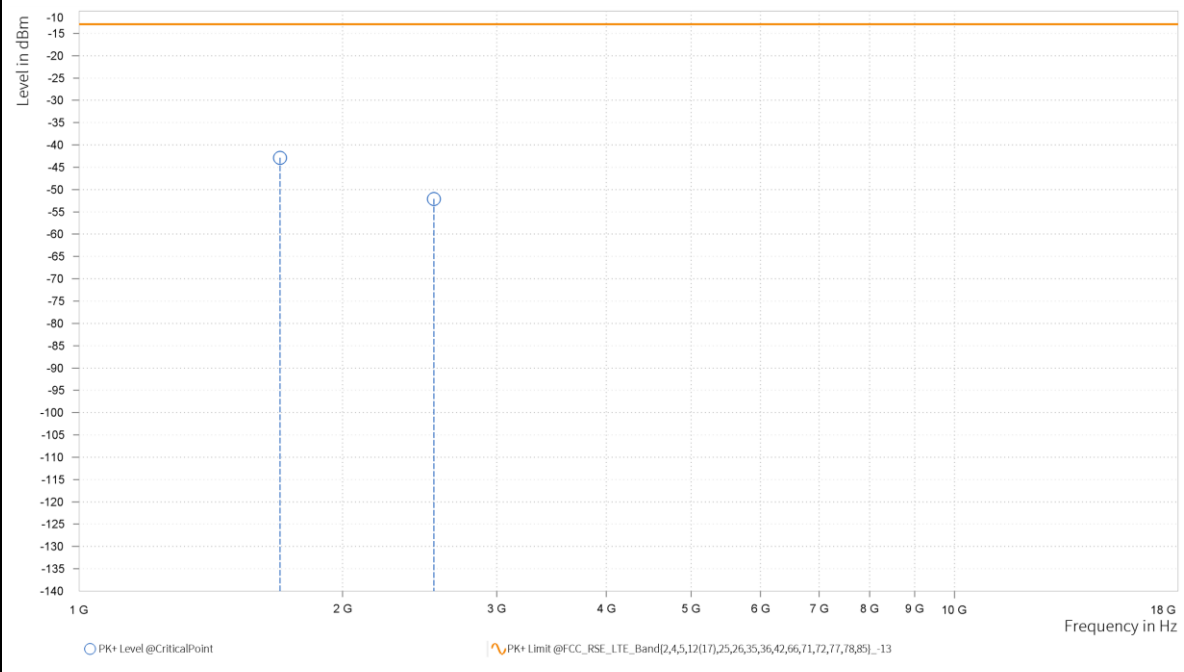



MODE	TX channel 20643	FREQUENCY RANGE	Above 1000MHz
ENVIRONMENTAL CONDITIONS	23deg. C, 70%RH	INPUT POWER	120Vac 60HZ
TESTED BY	Hanwen Xu		

ANTENNA POLARITY & TEST DISTANCE: VERTICAL AT 3 M

Rg	Frequency [MHz]	PK+ Level [dBm]	PK+ Limit [dBm]	PK+ Margin [dB]	Correction [dB]	Polarization	Azimuth [deg]	Antenna Height [m]
2	1,696.000	-45.36	-13.0	32.36	14.28	V	231.2	1.0
3	2,543.010	-50.93	-13.0	37.93	20.01	V	359.0	2.0

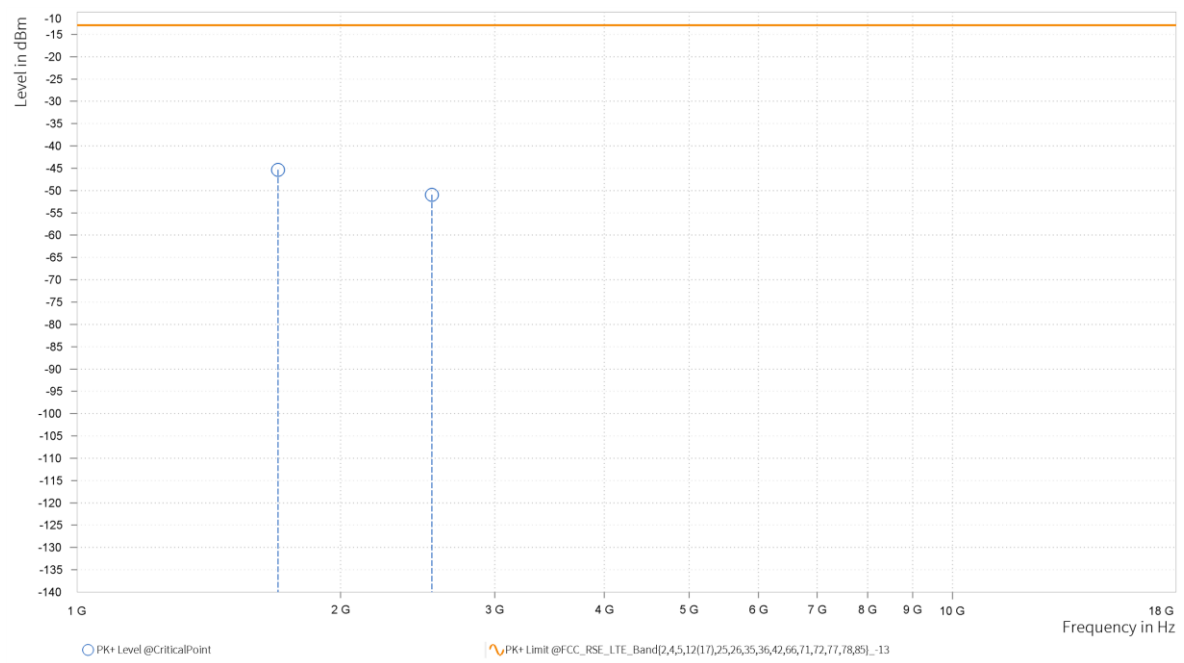



CHANNEL BANDWIDTH: 3MHz / QPSK

MODE	TX channel 20525	FREQUENCY RANGE	Above 1000MHz
ENVIRONMENTAL CONDITIONS	23deg. C, 70%RH	INPUT POWER	120Vac 60HZ
TESTED BY	Hanwen Xu		

ANTENNA POLARITY & TEST DISTANCE: HORIZONTAL AT 3 M

Rg	Frequency [MHz]	PK+ Level [dBm]	PK+ Limit [dBm]	PK+ Margin [dB]	Correction [dB]	Polarization	Azimuth [deg]	Antenna Height [m]
2	1,670.500	-42.55	-13.0	29.55	14.78	H	176.1	1.0
3	2,505.450	-50.21	-13.0	37.21	19.76	H	293.6	2.0

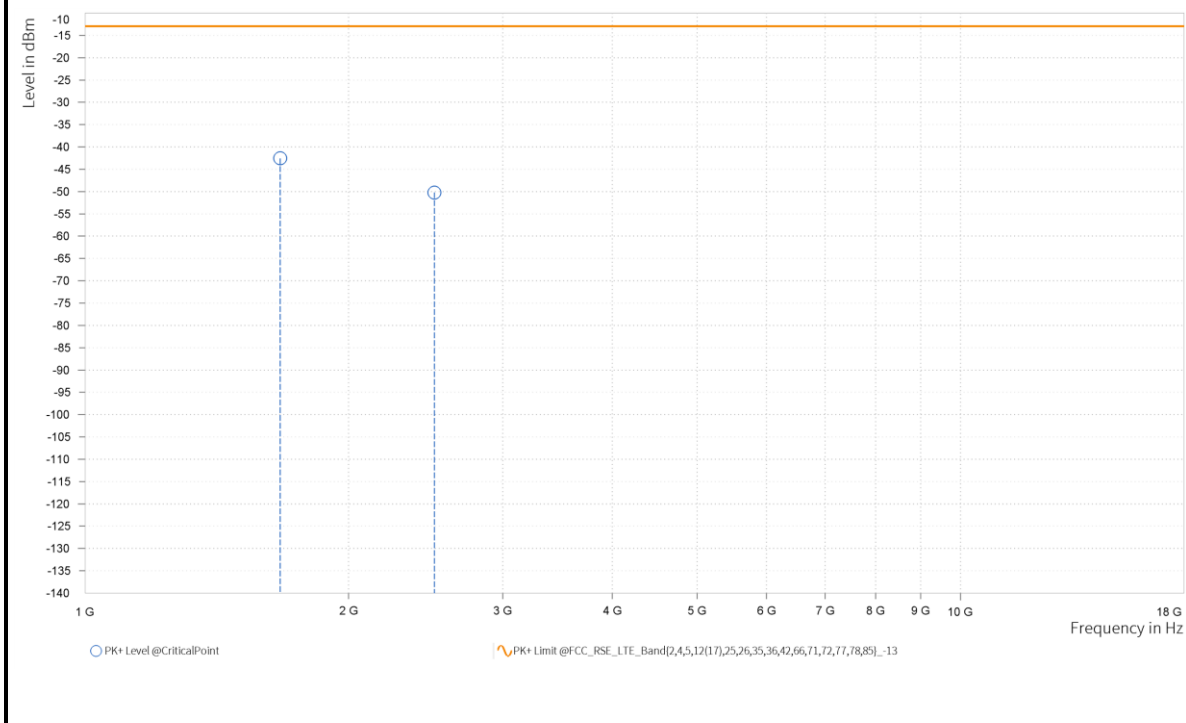



**BUREAU
VERITAS**

Test Report No.: PSU-NQN2406210109RF01

MODE	TX channel 20525	FREQUENCY RANGE	Above 1000MHz
ENVIRONMENTAL CONDITIONS	23deg. C, 70%RH	INPUT POWER	120Vac 60HZ
TESTED BY	Hanwen Xu		

ANTENNA POLARITY & TEST DISTANCE: VERTICAL AT 3 M

Rg	Frequency [MHz]	PK+ Level [dBm]	PK+ Limit [dBm]	PK+ Margin [dB]	Correction [dB]	Polarization	Azimuth [deg]	Antenna Height [m]
2	1,670.000	-42.79	-13.0	29.79	13.67	V	324.6	2.0
3	2,505.450	-50.26	-13.0	37.26	20.28	V	67.1	2.0

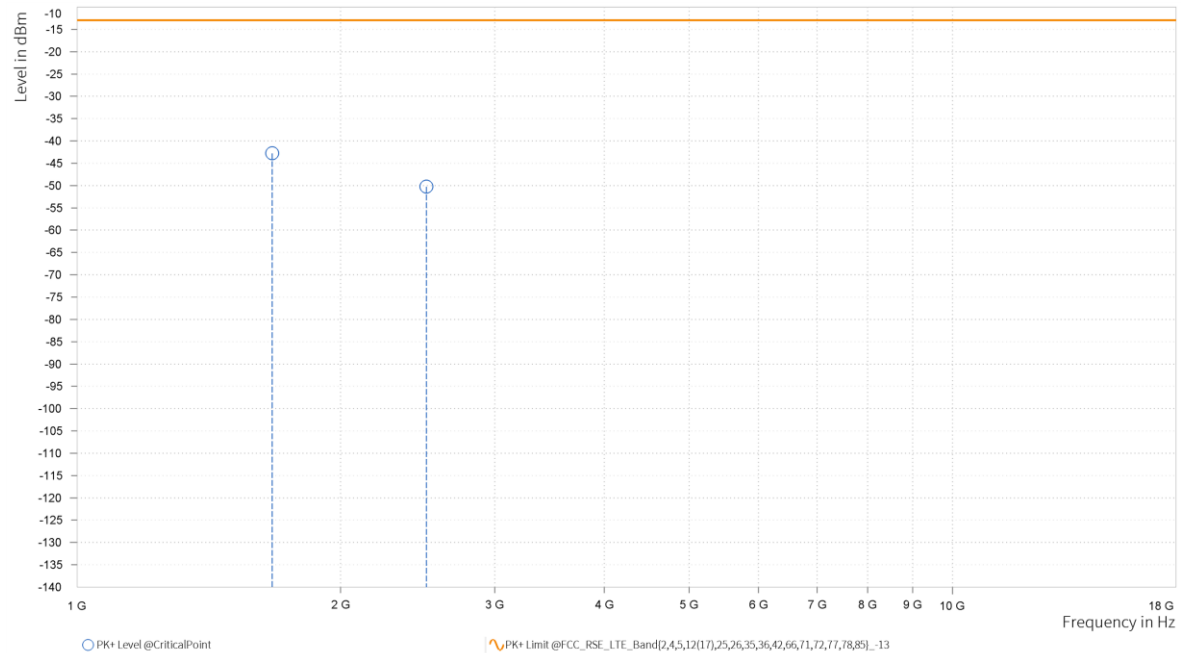



CHANNEL BANDWIDTH: 5MHz / QPSK

MODE	TX channel 20525	FREQUENCY RANGE	Above 1000MHz
ENVIRONMENTAL CONDITIONS	23deg. C, 70%RH	INPUT POWER	120Vac 60HZ
TESTED BY	Hanwen Xu		

ANTENNA POLARITY & TEST DISTANCE: HORIZONTAL AT 3 M

Rg	Frequency [MHz]	PK+ Level [dBm]	PK+ Limit [dBm]	PK+ Margin [dB]	Correction [dB]	Polarization	Azimuth [deg]	Antenna Height [m]
2	1,668.500	-41.43	-13.0	28.43	14.75	H	177.5	1.0
3	2,502.750	-50.0	-13.0	37.0	19.8	H	238.3	1.0

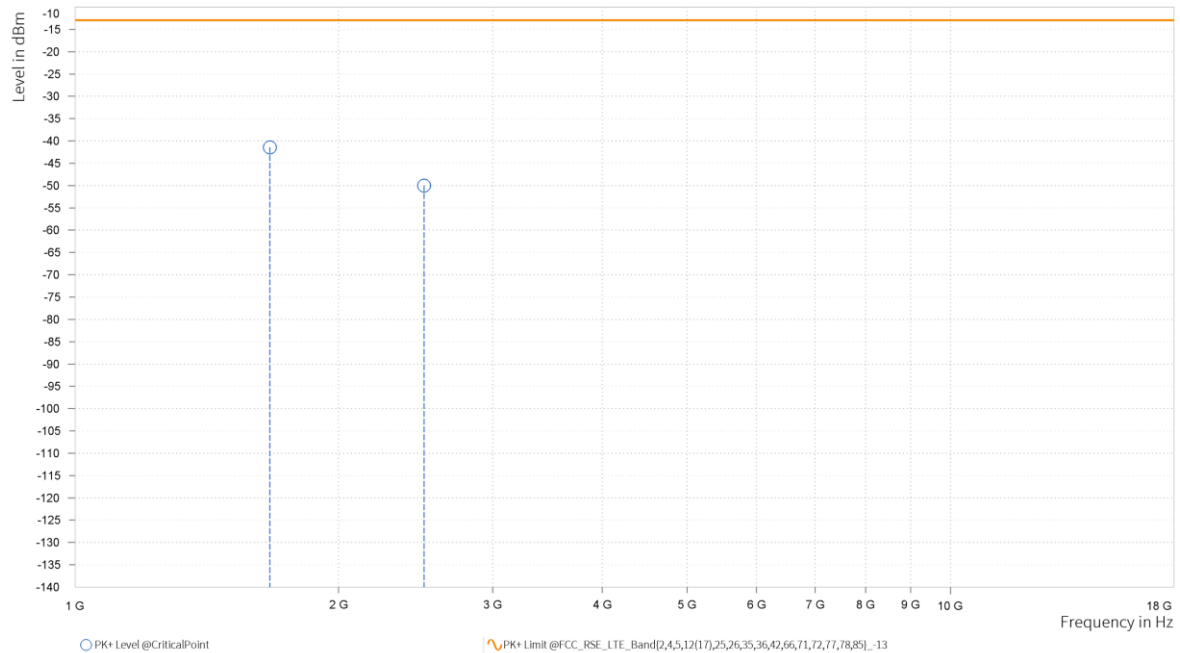



MODE	TX channel 20525	FREQUENCY RANGE	Above 1000MHz
ENVIRONMENTAL CONDITIONS	23deg. C, 70%RH	INPUT POWER	120Vac 60HZ
TESTED BY	Hanwen Xu		

ANTENNA POLARITY & TEST DISTANCE: VERTICAL AT 3 M

Rg	Frequency [MHz]	PK+ Level [dBm]	PK+ Limit [dBm]	PK+ Margin [dB]	Correction [dB]	Polarization	Azimuth [deg]	Antenna Height [m]
2	1,668.500	-43.43	-13.0	30.43	13.64	V	334.6	1.0
3	2,502.750	-49.01	-13.0	36.01	20.24	V	120.9	2.0

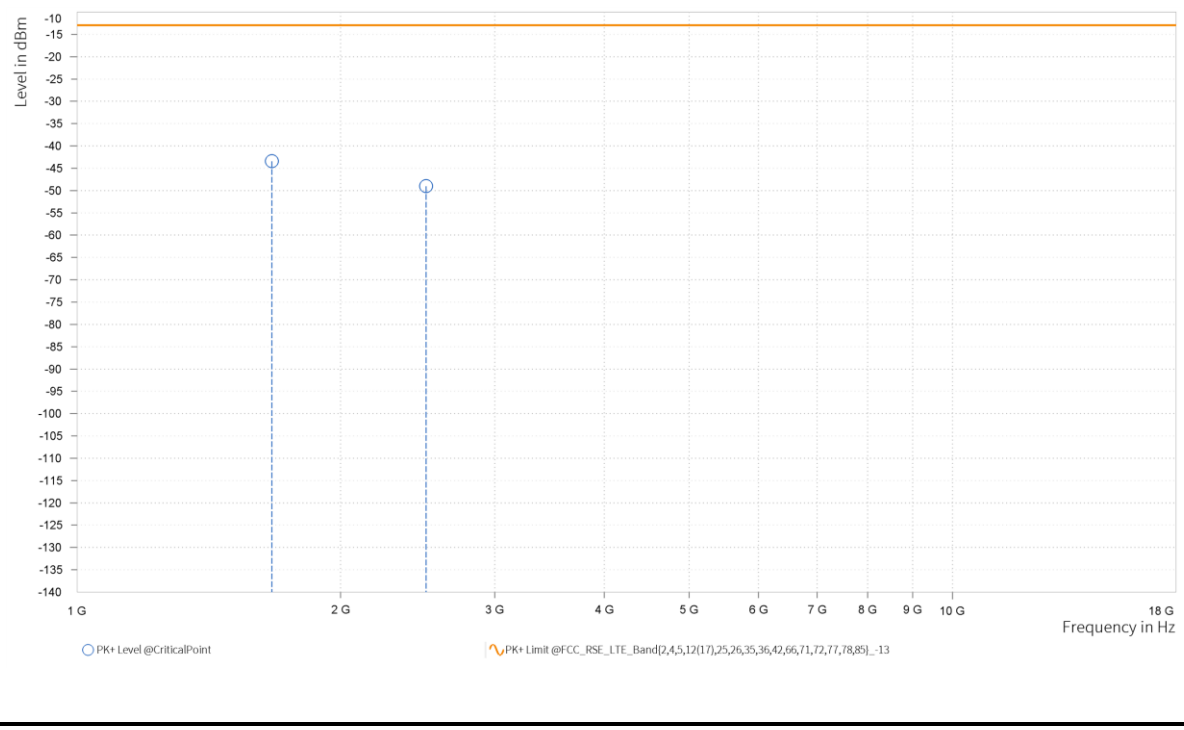



CHANNEL BANDWIDTH: 10MHz / QPSK

MODE	TX channel 20525	FREQUENCY RANGE	Above 1000MHz
ENVIRONMENTAL CONDITIONS	23deg. C, 70%RH	INPUT POWER	120Vac 60HZ
TESTED BY	Hanwen Xu		

ANTENNA POLARITY & TEST DISTANCE: HORIZONTAL AT 3 M

Rg	Frequency [MHz]	PK+ Level [dBm]	PK+ Limit [dBm]	PK+ Margin [dB]	Correction [dB]	Polarization	Azimuth [deg]	Antenna Height [m]
2	1,664.000	-41.59	-13.0	28.59	14.67	H	176.1	1.0
3	2,496.000	-49.74	-13.0	36.74	19.88	H	294.2	2.0

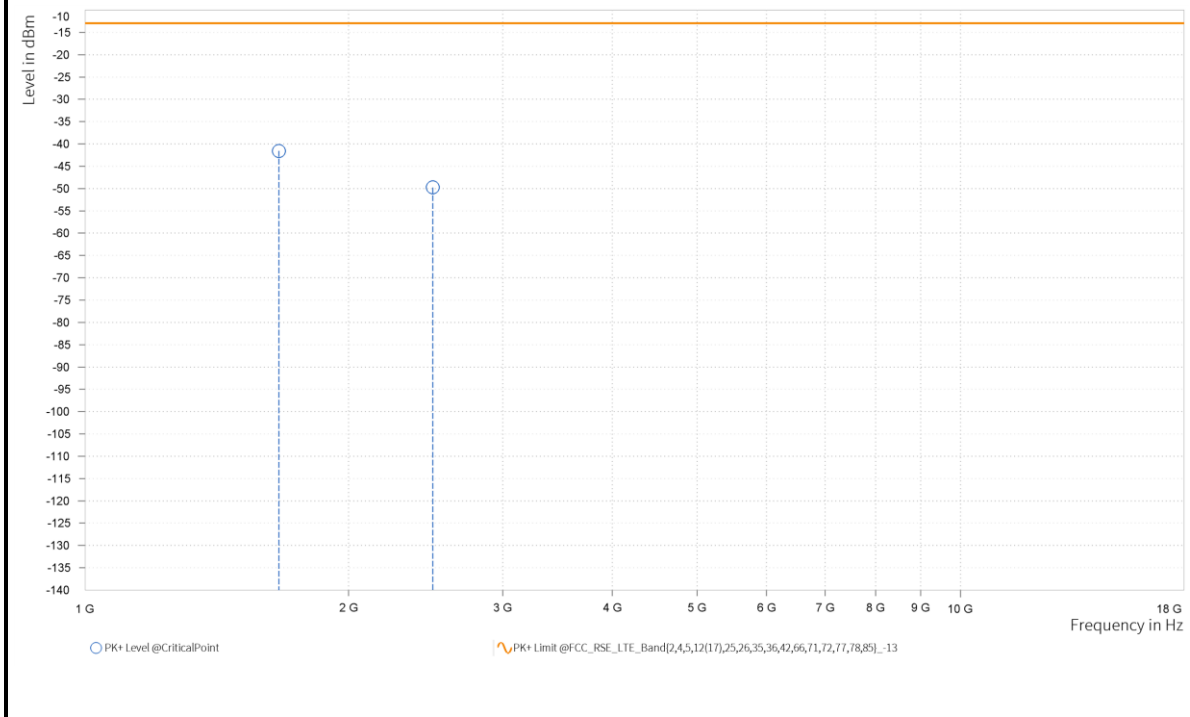



**BUREAU
VERITAS**

Test Report No.: PSU-NQN2406210109RF01

MODE	TX channel 20525	FREQUENCY RANGE	Above 1000MHz
ENVIRONMENTAL CONDITIONS	23deg. C, 70%RH	INPUT POWER	120Vac 60HZ
TESTED BY	Hanwen Xu		

ANTENNA POLARITY & TEST DISTANCE: VERTICAL AT 3 M

Rg	Frequency [MHz]	PK+ Level [dBm]	PK+ Limit [dBm]	PK+ Margin [dB]	Correction [dB]	Polarization	Azimuth [deg]	Antenna Height [m]
2	1,664.000	-44.04	-13.0	31.04	13.55	V	279.4	1.0
3	2,496.000	-50.96	-13.0	37.96	20.16	V	65.0	1.0

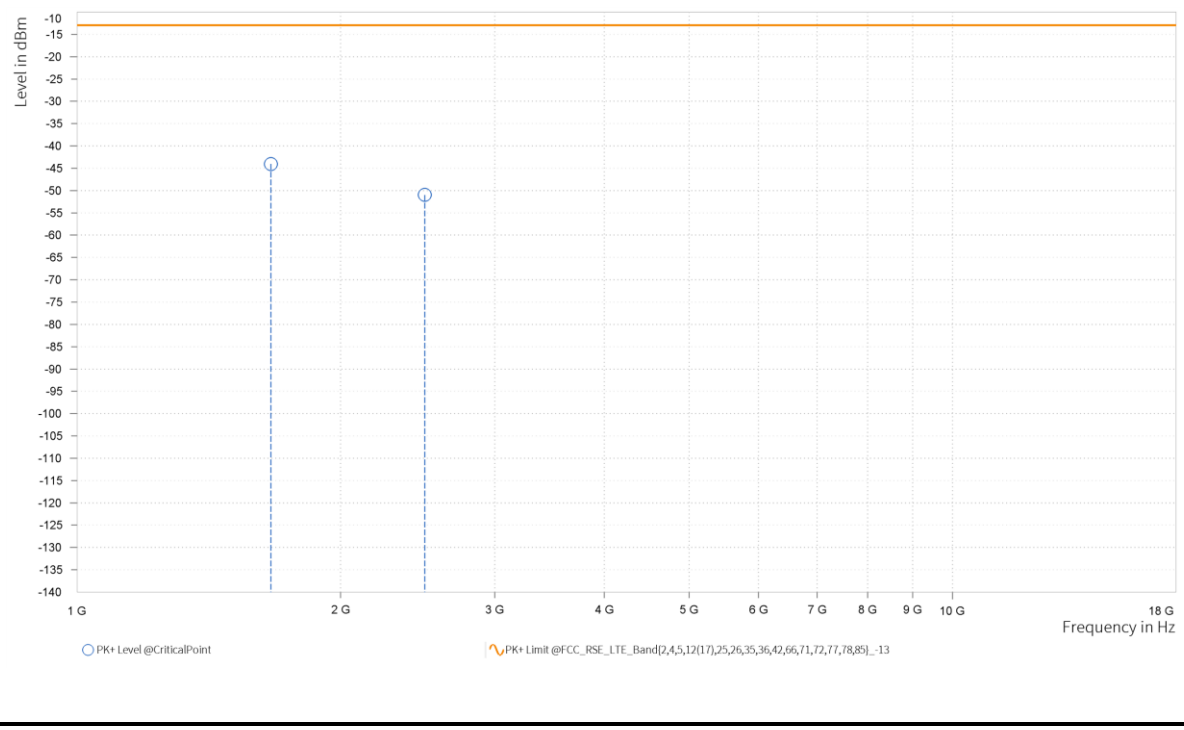



3.7 PEAK TO AVERAGE RATIO

3.7.1 LIMITS OF PEAK TO AVERAGE RATIO MEASUREMENT

In measuring transmissions in this band using an average power technique, the peak to-average ratio (PAR) of the transmission may not exceed 13 dB

3.7.2 TEST SETUP

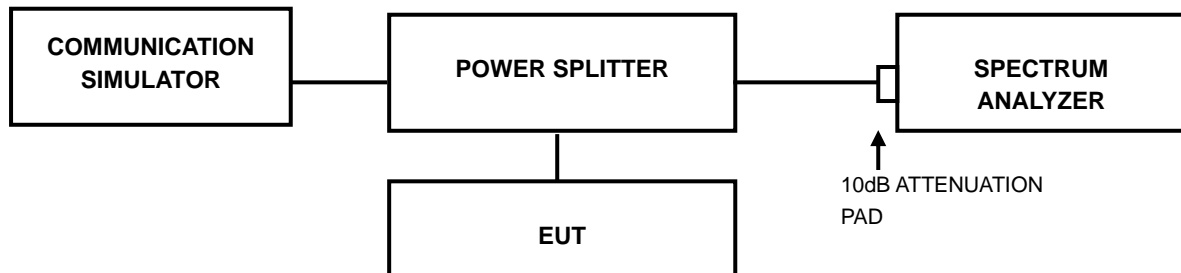

3.7.3 TEST PROCEDURES

1. Set resolution/measurement bandwidth \geq signal's occupied bandwidth;
2. Set the number of counts to a value that stabilizes the measured CCDF curve;
3. Record the maximum PAPR level associated with a probability of 0.1%.



Test Report No.: PSU-NQN2406210109RF01

3.7.4 TEST RESULTS

Please Refer to Appendix Of this test report.



Test Report No.: PSU-NQN2406210109RF01

4 PHOTOGRAPHS OF THE TEST CONFIGURATION

Please refer to the attached file (Test Setup Photo).



**BUREAU
VERITAS**

Test Report No.: PSU-NQN2406210109RF01

5 INFORMATION ON THE TESTING LABORATORIES

We, Huarui 7layers High Technology (Suzhou) Co., Ltd. ,were founded in 2020 to provide our best service in EMC, Radio, Telecom and Safety consultation. Our laboratories are accredited and approved according to ISO/IEC 17025.

Huarui 7Layers High Technology (Suzhou) Co., Ltd.

Lab Address:

Tower N, Innovation Center, 88 Zuyi Road, High-tech District, Suzhou City, Anhui Province

Accredited Test Lab Cert 6613.01

If you have any comments, please feel free to contact us at the following:

Suzhou EMC/RF Lab:

Tel: +86 (0557) 368 1008



Test Report No.: PSU-NQN2406210109RF01

6 MODIFICATIONS RECORDERS FOR ENGINEERING CHANGES TO THE EUT BY THE LAB

No any modifications are made to the EUT by the lab during the test.



7 APPENDIX:

GSM850

PEAK-TO-AVERAGE RATIO(CCDF)

Test Result

Band	Channel	Result(dB)	Limit(dB)	Verdict
GSM850	128	1.04	13	PASS
GSM850	189	1.14	13	PASS
GSM850	251	1.14	13	PASS
EGPRS850	128	3.38	13	PASS
EGPRS850	189	3.58	13	PASS
EGPRS850	251	2.92	13	PASS



BUREAU VERITAS

Test Report No.: PSU-NQN2406210109RF01

Test Graphs

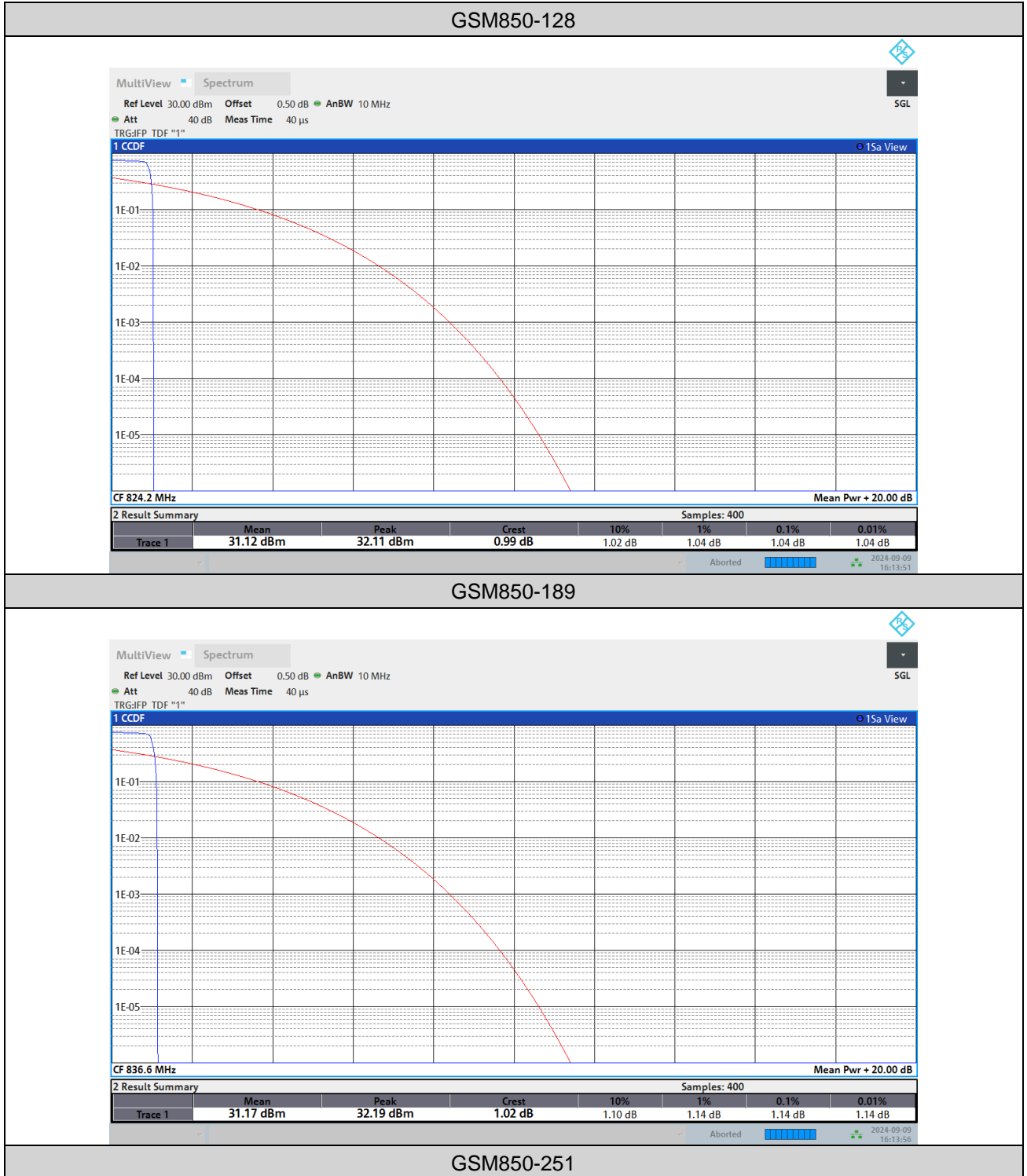



BUREAU VERITAS

Test Report No.: PSU-NQN2406210109RF01

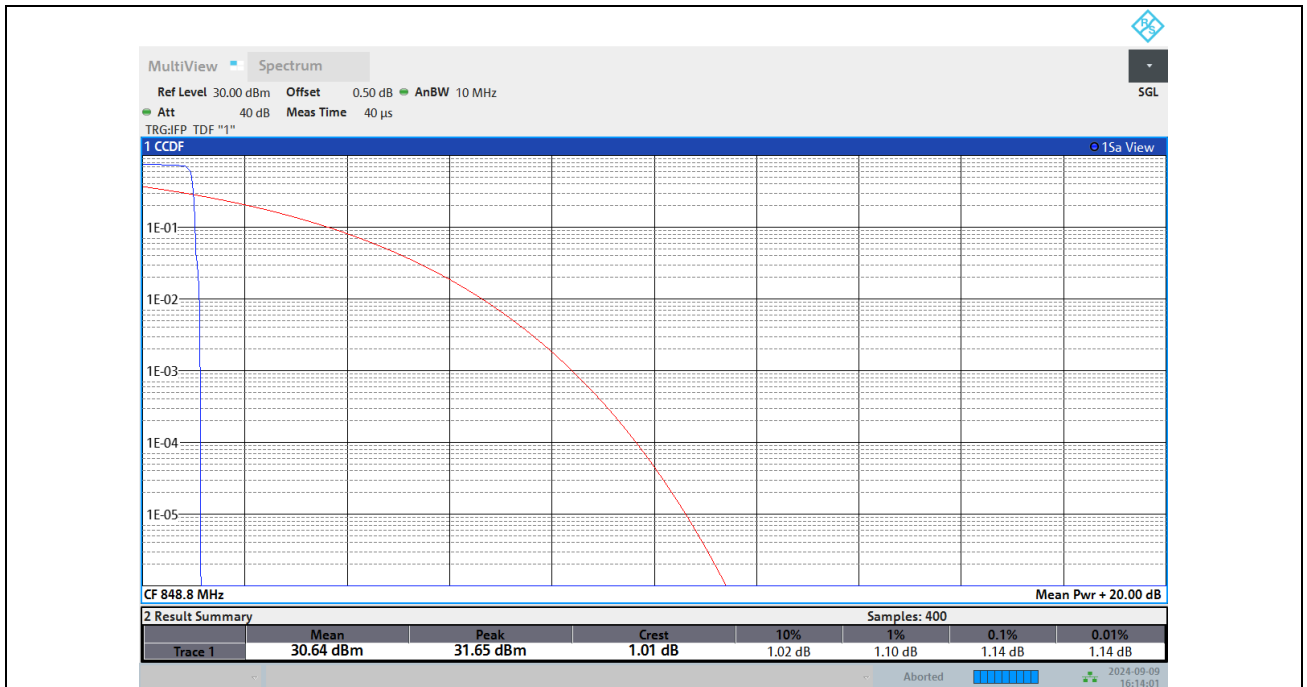

EGPRS850-128

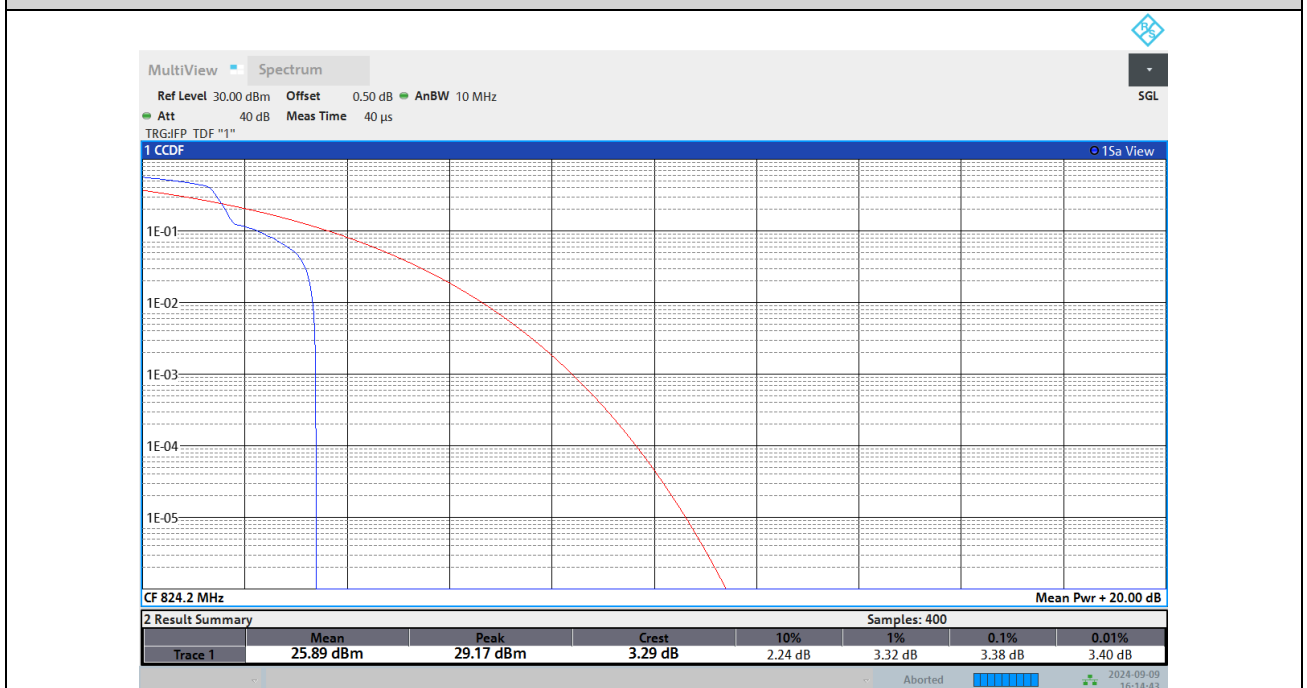

EGPRS850-189



BUREAU VERITAS

Test Report No.: PSU-NQN2406210109RF01

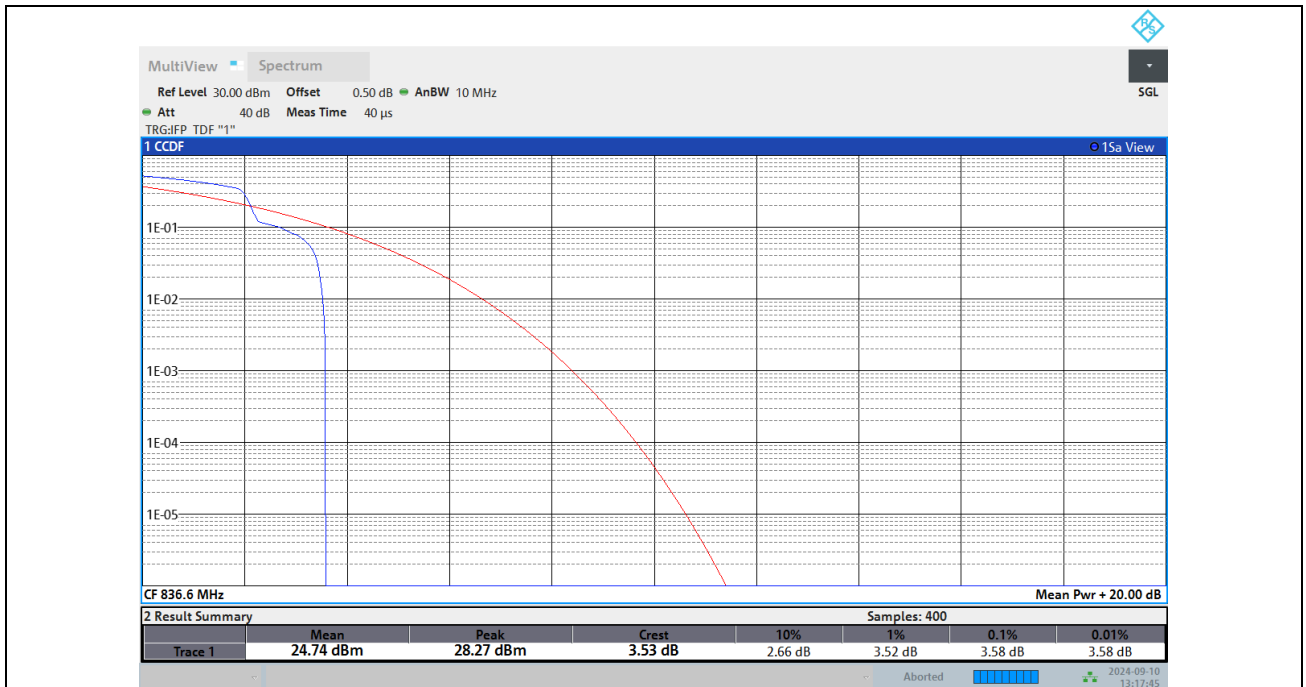

EGPRS850-251

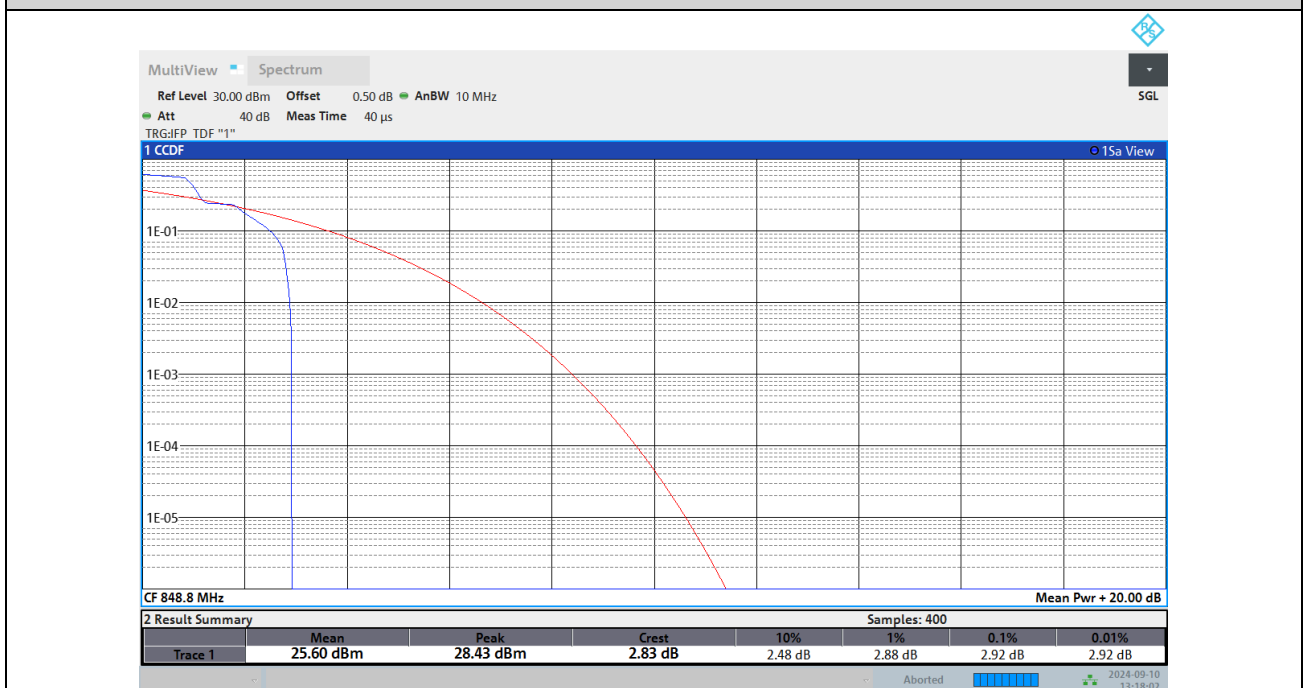



26DB BANDWIDTH AND OCCUPIED BANDWIDTH

Test Result

Band	Channel	Occupied Bandwidth (KHz)	26dB Bandwidth (KHz)	Verdict
GSM850	128	246.169	316.18	PASS
GSM850	189	244.860	318.68	PASS
GSM850	251	245.994	320.18	PASS
EGPRS850	128	245.527	316.18	PASS
EGPRS850	189	245.485	313.19	PASS
EGPRS850	251	248.303	316.18	PASS



BUREAU VERITAS

Test Report No.: PSU-NQN2406210109RF01

Test Graphs

Occupied Bandwidth

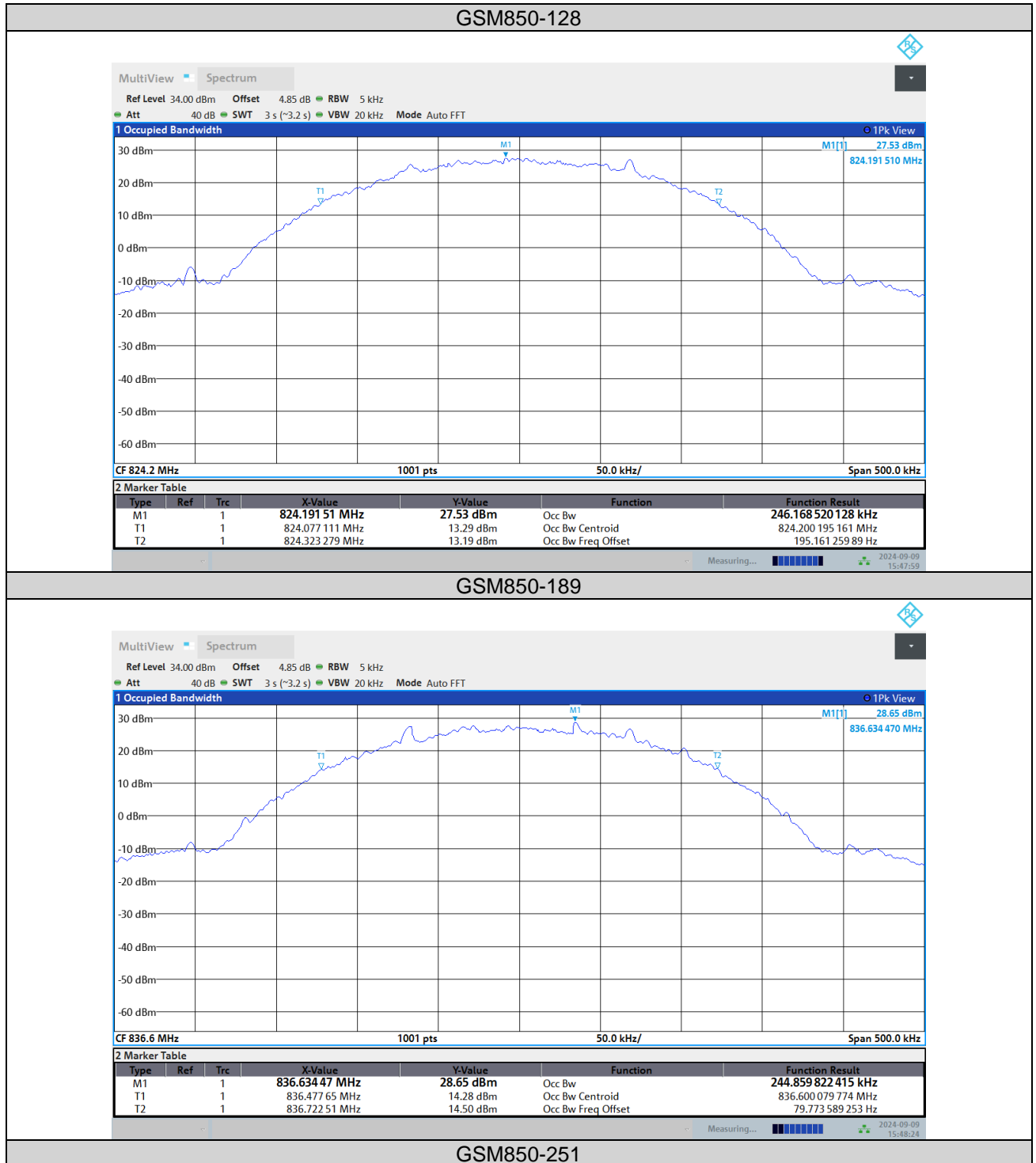



BUREAU VERITAS

Test Report No.: PSU-NQN2406210109RF01

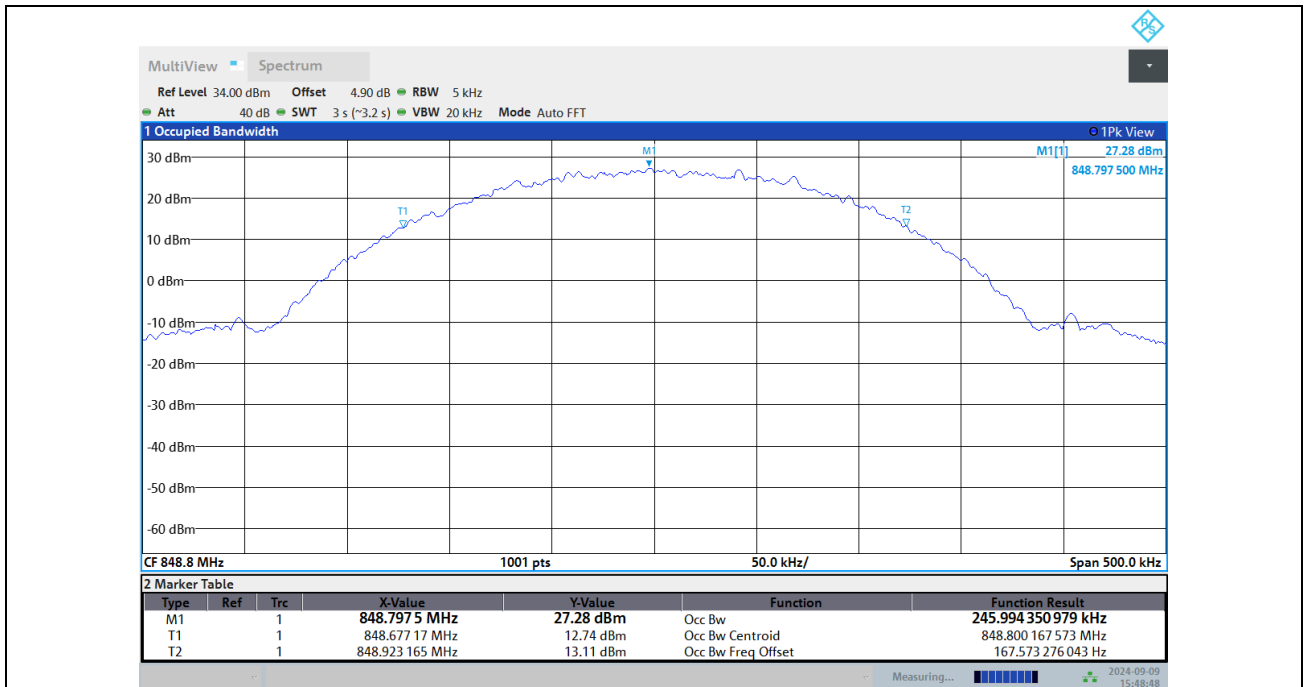

EGPRS850-128

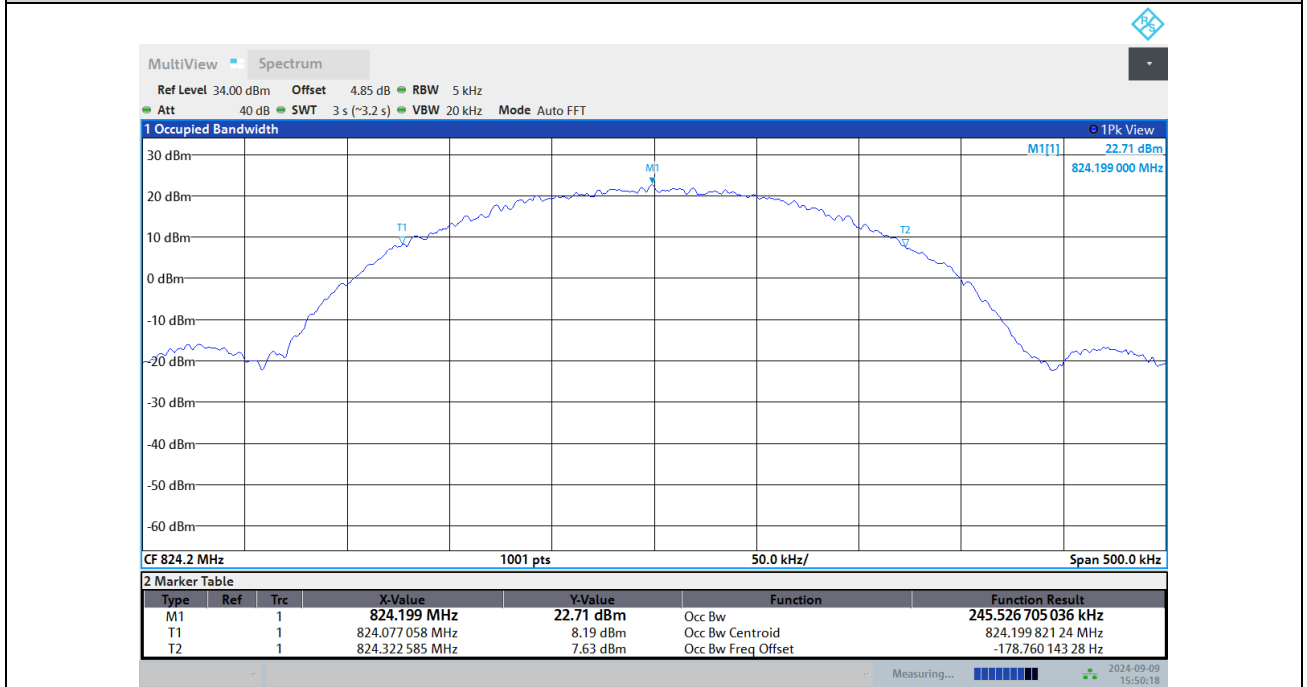

EGPRS850-189



BUREAU VERITAS

Test Report No.: PSU-NQN2406210109RF01

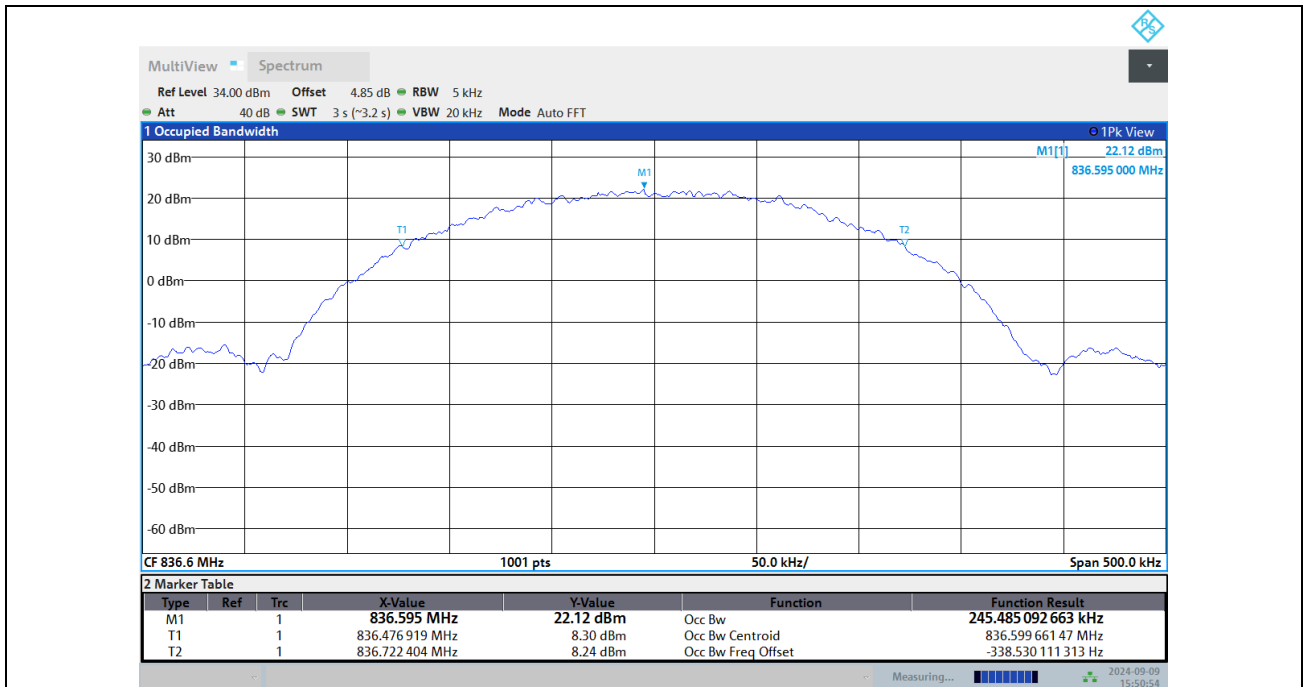

EGPRS850-251

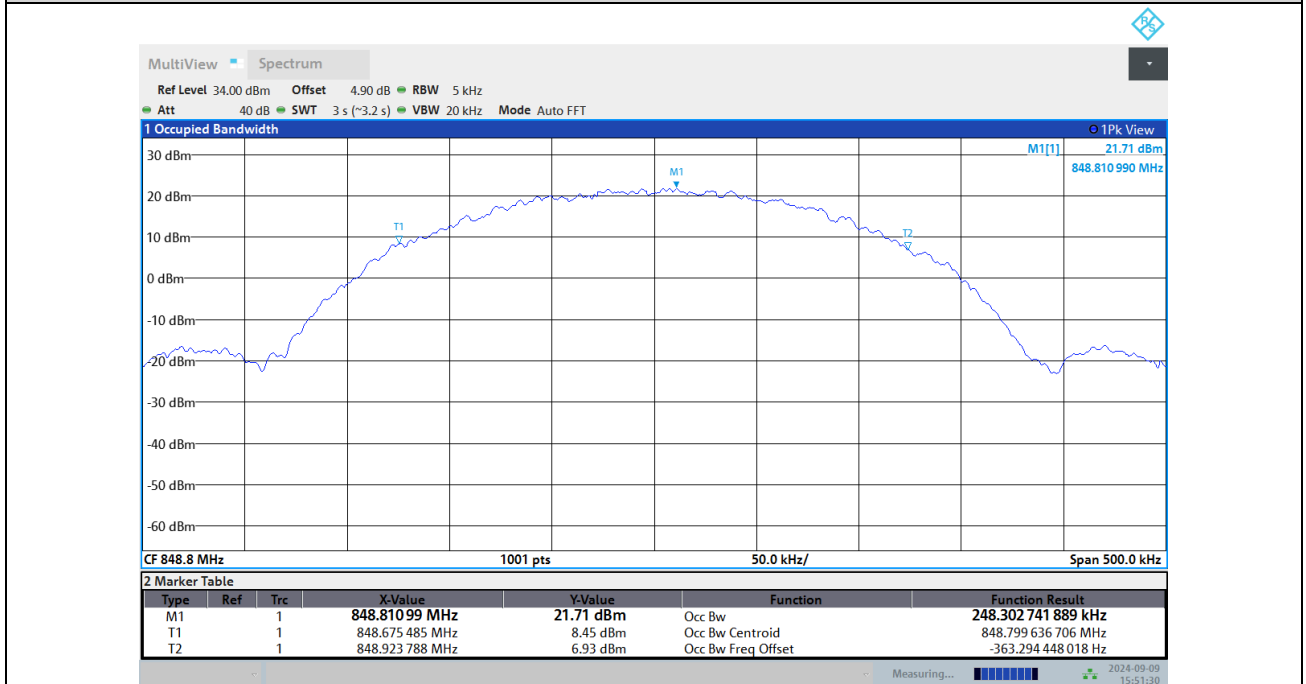

26dB Bandwidth

GSM850-128



BUREAU VERITAS

Test Report No.: PSU-NQN2406210109RF01

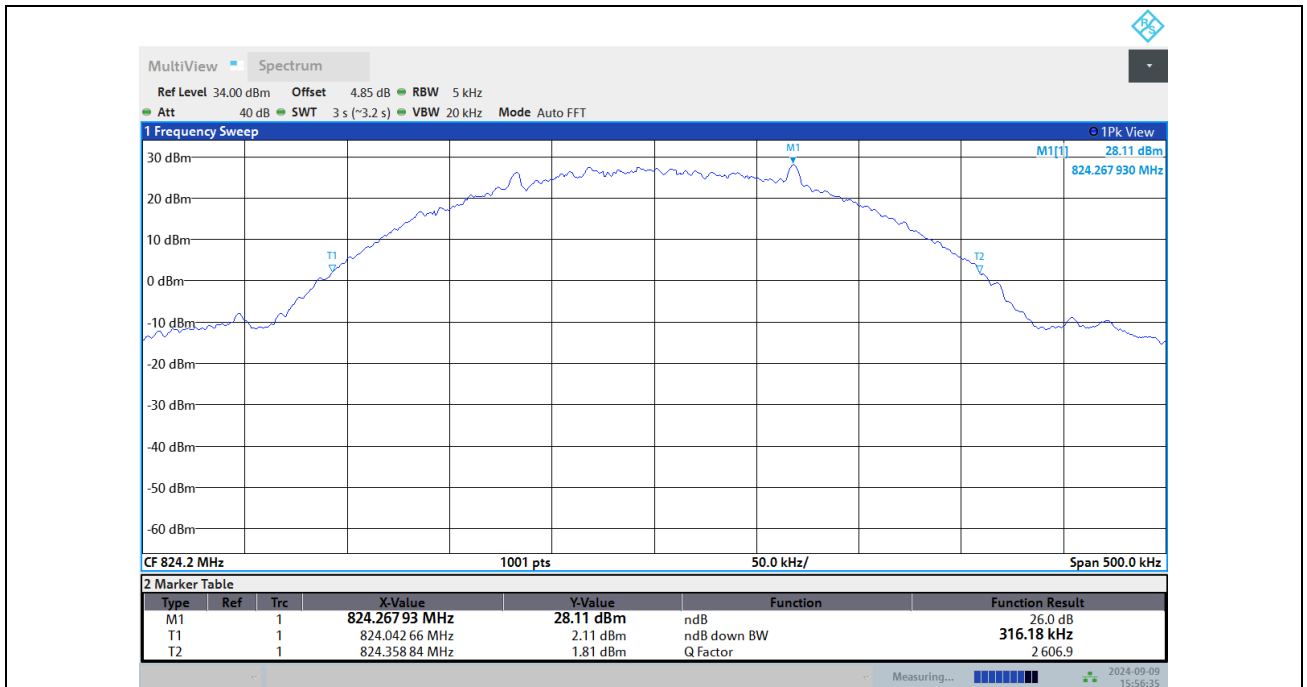

GSM850-189

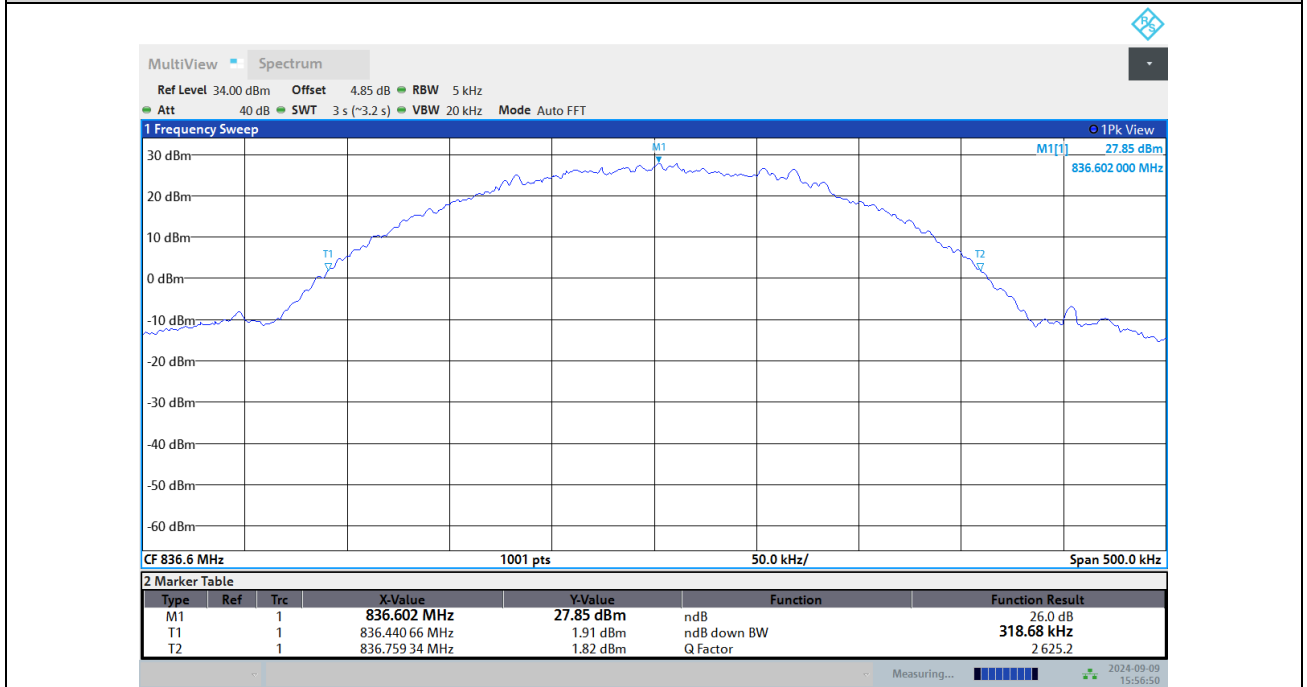

GSM850-251

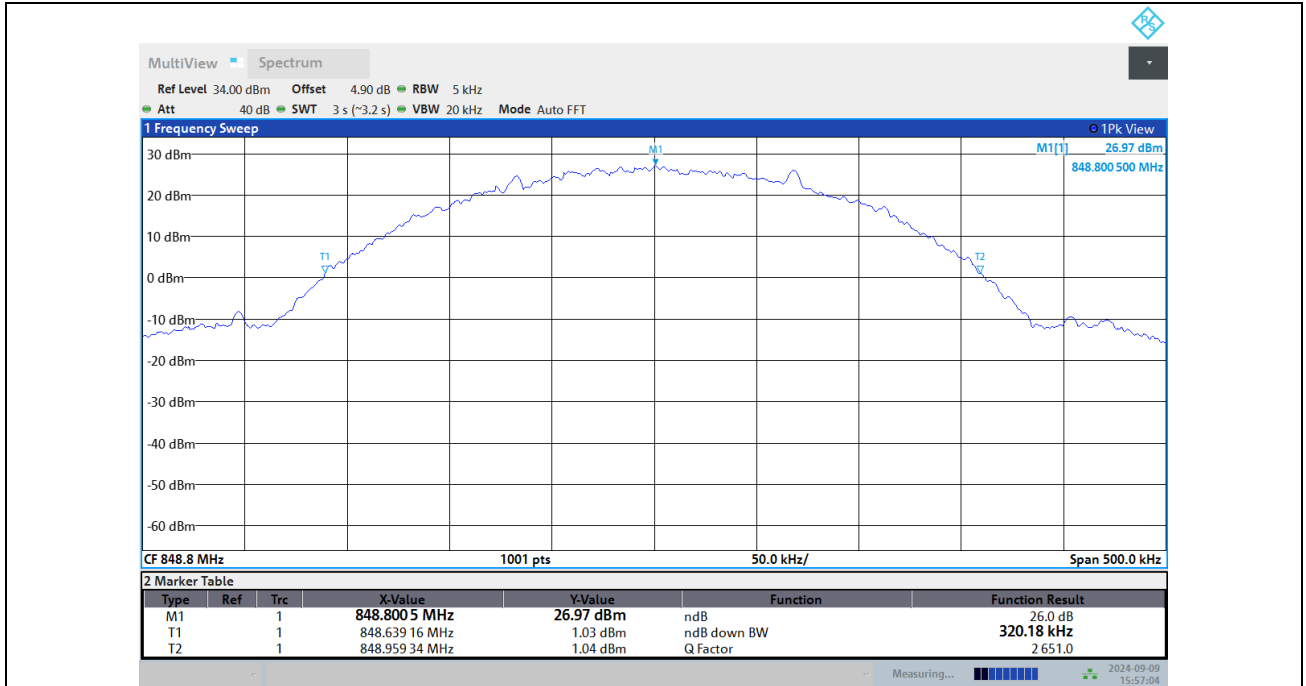

EGPRS850-128

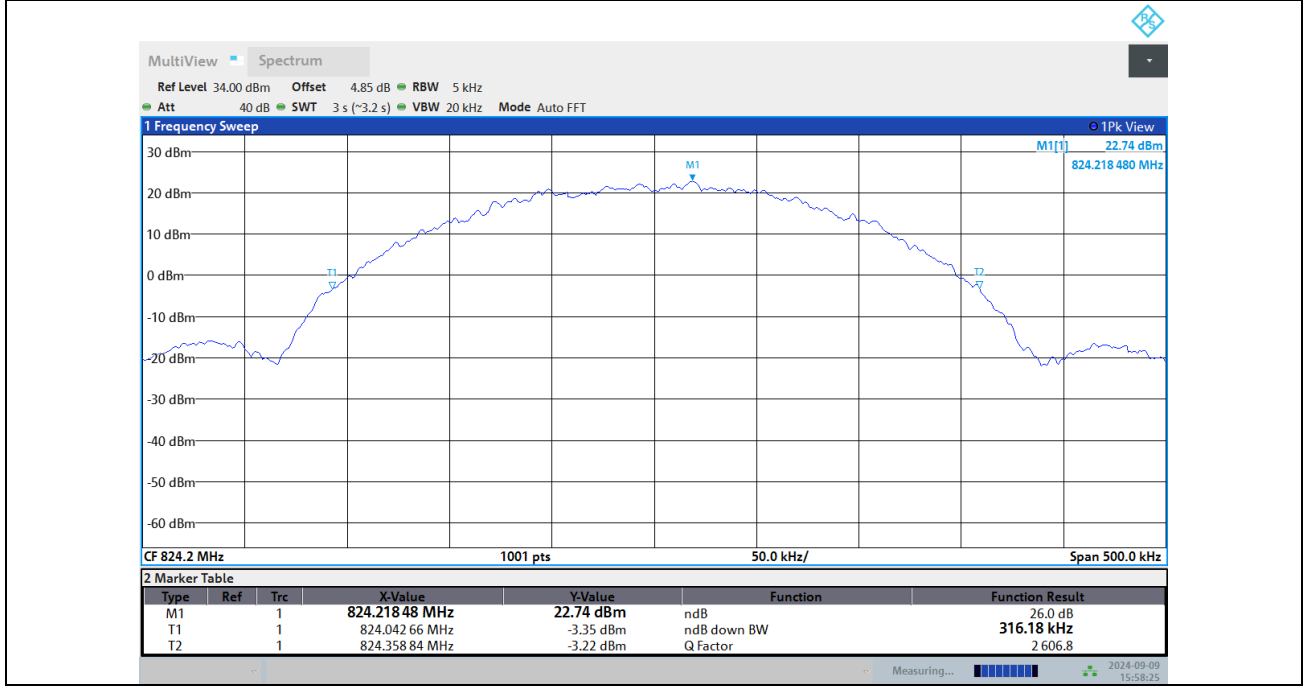

EGPRS850-189



**BUREAU
VERITAS**

Test Report No.: PSU-NQN2406210109RF01

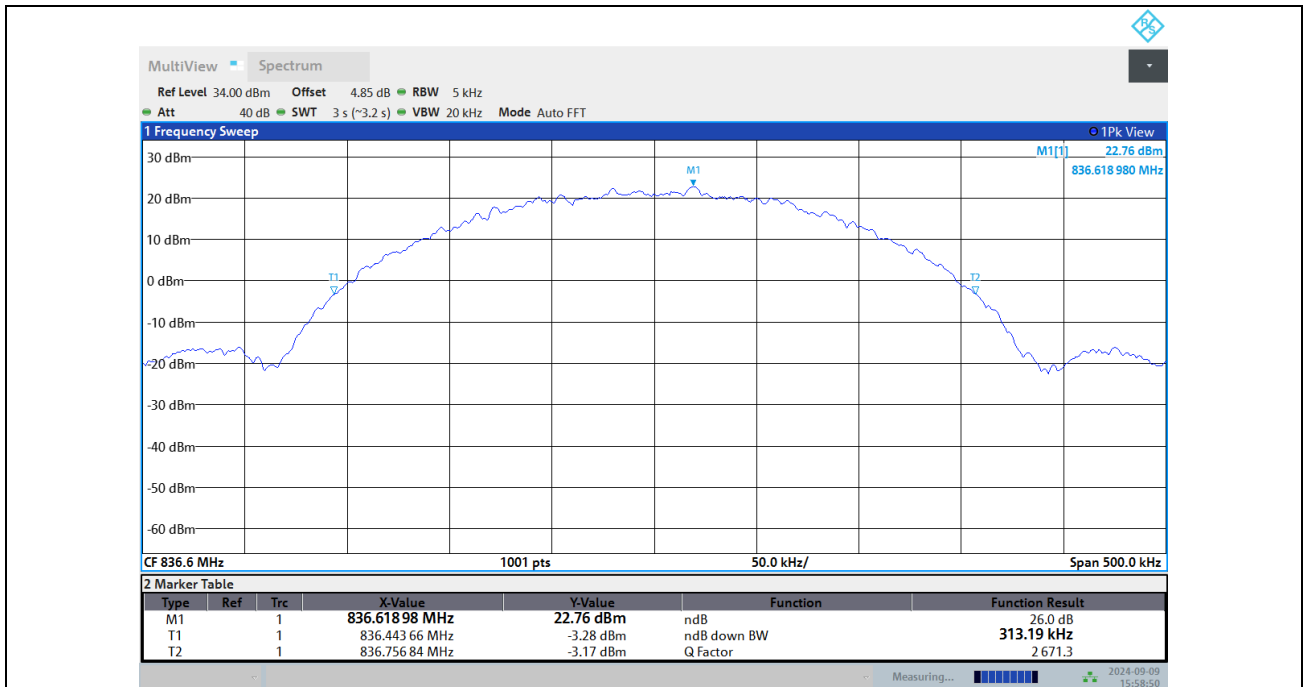

EGPRS850-251

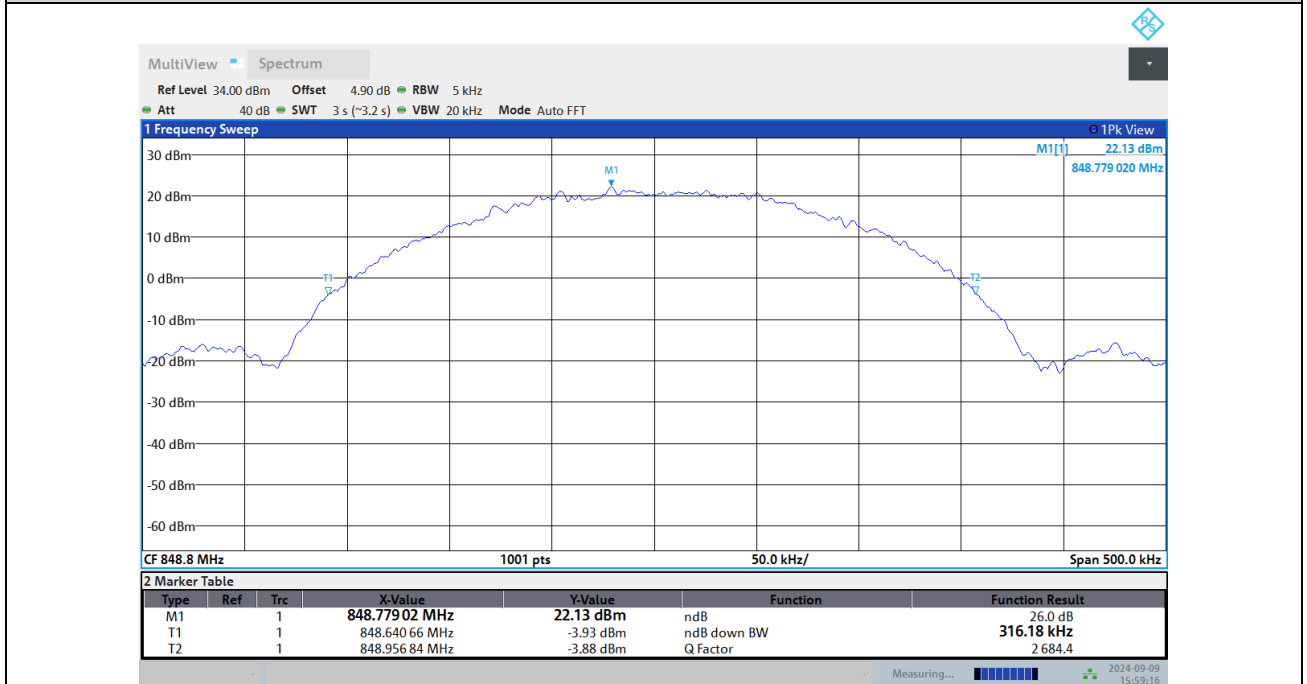



BAND EDGE

Test Result

Band	Channel	Freq (MHz)	Result (dBm)	Limit(dBm)	Verdict
GSM850	128	823.996	-27.93	-13	PASS
GSM850	251	849.022	-27.56	-13	PASS
EGPRS850	128	823.988	-35.51	-13	PASS
EGPRS850	251	849.036	-36.94	-13	PASS



BUREAU VERITAS

Test Report No.: PSU-NQN2406210109RF01

Test Graphs

