



Spectrum Research & Testing Lab., Inc.
No. 101-10, Ling 8,
Shan-Tong Li, Chung-Li
City, Taoyuan, Taiwan

TEST REPORT

Reference No.: A11051302
Report No.: FCC A11051302
FCC ID : ZL7RIDE-SENSE-G1
Page: 1 of 20
Date: Jun. 03, 2011

Product Name: Ride Sense Sensor
Model No.: Ride Sense G1
Applicant: Giant Manufacturing Co., Ltd.
19, Shun-Farn Road, Tachia Area, Taichung City, 43774, Taiwan,
R.O.C.
Date of Receipt: May. 13, 2011
Finished date of Test: Jun. 03, 2011
Applicable Standards: 47 CFR Part 15, Subpart C
ANSI C63.4: 2003

We, **Spectrum Research & Testing Laboratory Inc.**, hereby certify that one sample of the above was tested in our laboratory with positive results according to the above-mentioned standards. The records in the report are an accurate account of the results. Details of the results are given in the subsequent pages of this report.

Tested By : Richard Lin , Date: 6/3/2011
(Richard Lin)

Approved By : JH , Date: 6/3/2011
(Johnson Ho, Director)





Table of Contents

1.	DOCUMENT POLICY AND TEST STATEMENT	3
1.1	DOCUMENT POLICY	3
1.2	TEST STATEMENT	3
1.3	EUT MODIFICATION.....	3
2.	DESCRIPTION OF EUT AND TEST MODE	4
2.1	GENERAL DESCRIPTION OF EUT	4
2.2	DESCRIPTION OF EUT INTERNAL DEVICE	4
2.3	DESCRIPTION OF TEST MODE.....	5
2.4	DESCRIPTION OF SUPPORT UNIT	5
2.5	EUT OPERATING CONDITION.....	5
3.	DESCRIPTION OF APPLIED STANDARDS.....	6
4.	TECHNICAL CHARACTERISTICS TEST	7
4.1	CONDUCTED EMISSION TEST	7
4.1.1	LIMIT	7
4.1.2	TEST EQUIPMENT	7
4.1.3	TEST SETUP.....	8
4.1.4	TEST PROCEDURE.....	8
4.1.5	TEST RESULT.....	8
4.2	RADIATED EMISSION TEST	9
4.2.1	LIMIT	9
4.2.2	TEST EQUIPMENT	10
4.2.3	TEST SET-UP.....	11
4.2.4	TEST PROCEDURE.....	12
4.2.5	TEST RESULT.....	13
5.	ANTENNA APPLICATION	17
5.1	ANTENNA REQUIREMENT	17
5.2	RESULT.....	17
6.	PHOTOS OF TESTING	18
7.	TERMS OF ABBREVIATION	20



**Spectrum Research &
Testing Lab., Inc.**
No. 101-10, Ling 8,
Shan-Tong Li, Chung-Li
City, Taoyuan, Taiwan

TEST REPORT

Reference No.: A11051302
Report No.: FCC A11051302
FCC ID : ZL7RIDE-SENSE-G1
Page:3 of 20
Date: Jun. 03, 2011

1. DOCUMENT POLICY AND TEST STATEMENT

1.1 DOCUMENT POLICY

- The report shall not be reproduced except in full, without the written approval of SRT Lab, Inc.

1.2 TEST STATEMENT

- The test results in the report apply only to the unit tested by SRT Lab.
- There was no deviation from the requirements of test standards during the test.
- DC power source, 3Vdc/65uA, was used during the test.

1.3 EUT MODIFICATION

- No modification in SRT Lab.



2. DESCRIPTION OF EUT AND TEST MODE

2.1 GENERAL DESCRIPTION OF EUT

PRODUCT	Ride Sense Sensor
MODEL NO.	Ride-Sense-G1
POWER SUPPLY	DC power source from battery : 3Vdc/65uA
CABLE	NA
FREQUENCY BAND	2.400GHz ~ 2.480GHz
CARRIER FREQUENCY	2.457GHz
CHANNEL SPACING	1MHz
NUMBER OF CHANNEL	1
RATED RF OUTPUT POWER	-2.96dBm(e.i.r.p)
MODULATION TYPE	GFSK
BIT RATE OF TRANSMISSION	250Kbit/sec
MODE OF OPERATION	Simplicx
ANTENNA TYPE	Chip Antenna
ANTENNA GAIN	2 dBi
OPERATING TEMPERATURE RANGE	-10 ~ 60°C

NOTE :

For more detailed information, please refer to the EUT's specification or user's manual provided by manufacturer.

2.2 DESCRIPTION OF EUT INTERNAL DEVICE

DEVICE	BRAND / MAKER	MODEL #	FCC ID / DOC	REMARK
NA				

	Spectrum Research & Testing Lab., Inc. No. 101-10, Ling 8, Shan-Tong Li, Chung-Li City, Taoyuan, Taiwan	<h1>TEST REPORT</h1>	Reference No.: A11051302 Report No.: FCC A11051302 FCC ID : ZL7RIDE-SENSE-G1 Page:5 of 20 Date: Jun. 03, 2011
---	---	----------------------	---

2.3 DESCRIPTION OF TEST MODE

Mode	
1	TX
2	Standby

Note: The axis X,Y and Z we evaluate in chamber, the X axis is worst case.

X axis:



Y axis:



Z axis:



2.4 DESCRIPTION OF SUPPORT UNIT

The EUT was configured by the requirement of ANSI C63.4:2003. All interface ports were connected to the appropriate support units via specific cables. The support units and cables are listed below.

NO	DEVICE	BRAND	MODEL #	FCC ID/DOC	CABLE
1	USB2 (Wireless)	Dynastream	011-02209-1	06RUSB2	

NOTE : For the actual test configuration, please refer to the photos of testing.

2.5 EUT OPERATING CONDITION

1. Setup the EUT and all peripheral devices .
2. Turn on the power of all equipment and EUT.
3. Set the EUT under continuous transmission condition or standby.
4. The EUT was set to the highest available power level.



**Spectrum Research &
Testing Lab., Inc.**
No. 101-10, Ling 8,
Shan-Tong Li, Chung-Li
City, Taoyuan, Taiwan

TEST REPORT

Reference No.: A11051302
Report No.: FCC A11051302
FCC ID : ZL7RIDE-SENSE-G1
Page:6 of 20
Date: Jun. 03, 2011

3. DESCRIPTION OF APPLIED STANDARDS

The EUT is a wireless product. According to the specifications provided by the applicant, it must comply with the requirements of the following standards:

47 CFR Part 15, Subpart C

ANSI C63.4: 2003

All tests have been performed and recorded as the above standards.



4. TECHNICAL CHARACTERISTICS TEST

4.1 CONDUCTED EMISSION TEST

4.1.1 LIMIT

Frequency (MHz)	Class A (dB μ V)		Class B (dB μ V)	
	Quasi-peak	Average	Quasi-peak	Average
0.15 - 0.5	79	66	66 - 56	56 - 46
0.50 - 5.0	73	60	56	46
5.0 - 30.0	73	60	60	50

NOTE :

1. The lower limit shall apply at the transition frequencies.
2. The limit decreases in line with the logarithm of the frequency in the range of 0.15 to 0.50 MHz.

4.1.2 TEST EQUIPMENT

The following test equipment was used for the test:

EQUIPMENT/ FACILITIES	SPECIFICATIONS	MANUFACTURER	MODEL#/ SERIAL#	DUE DATE OF CAL. & CAL. CENTER
EMI TEST RECEIVER	9kHz TO 2.75 GHz	ROHDE & SCHWARZ	ESHS30 / 826003/008	SEP. 2011 ETC
LISN	50 μ H, 50 ohm	FCC	FCC-LISN-50-25-2 / 01017	JUL. 2011 ETC
LISN	50 μ H, 50 ohm	SOLAR	9252-50-R24-BNC / 951315	NOV. 2011 ETC
50 OHM TERMINATOR	50 ohm	HP	11593A / #2	MAY 2012 ETC
COAXIAL CABLE	5M	TIMES	RG214/U / #5M(L1TCAB013)	MAY. 2012 ETC
Filter	2 LINE, 30A	FIL.COIL	FC-943 / 771	NCR
GROUND PLANE	2M (H) x 3M (W)	SRT	N/A	NCR
GROUND PLANE	2.5M (H) x 3M (W)	SRT	N/A	NCR

NOTE: The calibration interval of the above test equipment is one year and the calibrations are traceable to NML/ROC and NIST/USA.



4.1.3 TEST SETUP

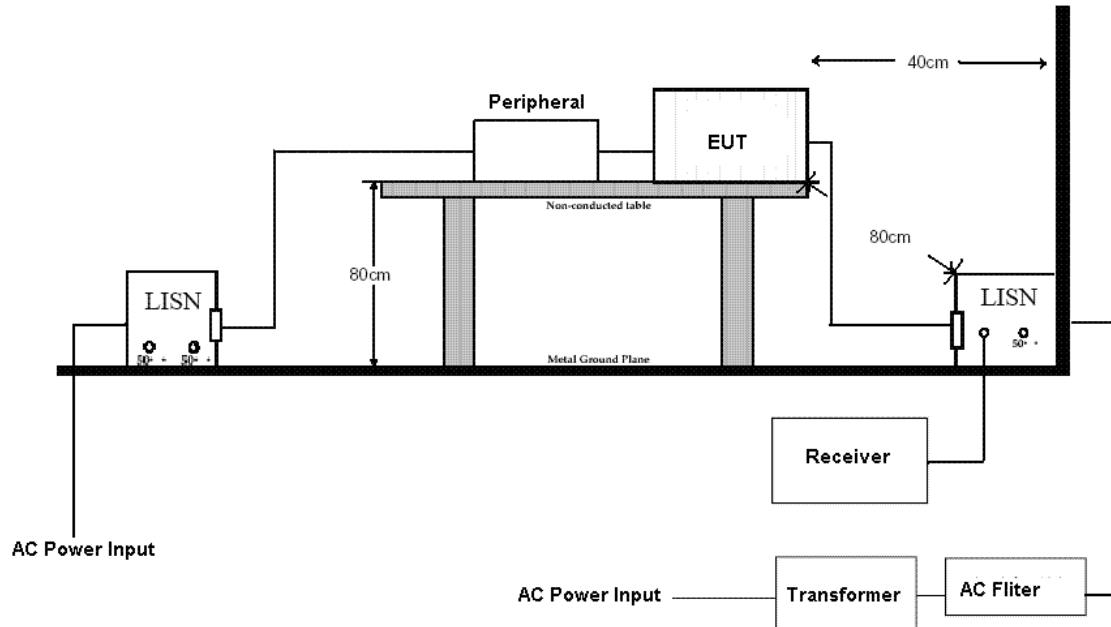

NOTE :

1. The EUT was put on a wooden table with 0.8m heights above ground plane, and 0.4m away from reference ground plane (> 2mx2m).
2. For the actual test configuration, please refer to the photos of testing.

4.1.4 TEST PROCEDURE

The EUT was tested according to the requirement of ANSI C63.4:2003 and CISPR22:2003. The frequency spectrum from 0.15 MHz to 30 MHz was investigated. The LISN used was 50 ohm/50 μ H as specified. All readings were quasi-peak and average values with 10 kHz resolution bandwidth of the test receiver. The EUT system was operated in all typical methods by users. Both lines of the power mains of EUT were measured and the cables connected to EUT and support units were moved to find the maximum emission levels for each frequency. First, find the margin or higher points at least 6 points by software, then use manual to find the maximum data. The procedure is referred on the test procedure of SRT LAB.

4.1.5 TEST RESULT

The test item was not performed, because the EUT uses 3.0Vdc battery as power source.



4.2 RADIATED EMISSION TEST

4.2.1 LIMIT

FCC Part15, Subpart C Section 15.209 limit of radiated emission for frequency below1000MHz. The emissions from an intentional radiator shall not exceed the field strength levels specified in the following table:

FREQUENCY (MHz)	DISTANCE (m)	FIELD STRENGTH (dB μ V/m)
0.009 - 0.490	300	2400/F(KHz)
0.490 - 1.705	30	24000/F(KHz)
1.705 - 30	30	30
30 - 88	3	40.0
88 - 216	3	43.5
216 - 960	3	46.0
Above 960	3	54.0

FCC Part15, Subpart C Section 15.249 limit of radiated emission for frequency below1000MHz (Average).

FREQUENCY (MHz)	FIELD STRENGTH OF FUNDAMENTAL (millivolts/meter)	FIELD STRENGTH OF HARMONICS (millivolts/meter)
902 - 928	50	500
2400 - 2483.5	50	500
5725 - 5875	50	500
24000 - 24250	250	2500

NOTE :

1. In the emission tables above , the tighter limit applies at the band edges.
2. Distance refers to the distance between measuring instrument, antenna, and the closest point of any part of the device or system.
3. 50mV = 94dBuV

FCC Part 15, Section15.35(b) limit of radiated emission for frequency above 1000 MHz

FREQUENCY (MHz)	Class A (dBuV/m) (at 3m)		Class B (dBuV/m) (at 3m)	
	PEAK	AVERAGE	PEAK	AVERAGE
Above 1000	80.0	60.0	74.0	54.0



TEST REPORT

4.2.2 TEST EQUIPMENT

The following test equipment was used during the radiated emission test:

EQUIPMENT/ FACILITIES	SPECIFICATIONS	MANUFACTURER	MODEL#/ SERIAL#	DUE DATE OF CAL. & CAL. CENTER
EMI TEST RECEIVER	20 MHz TO 1000 MHz	ROHDE & SCHWARZ	ESVS30 / 841977/003	DEC. 2011 ETC
BI-LOG ANTENNA	30 MHz TO 2 GHz	SCHAFFNER	CBL6141A / 4181	MAY. 2012 ETC
OATS	3 – 10 M MEASUREMENT	SRT	SRT-1	NOV. 2011 SRT
COAXIAL CABLE	30M	TIMES	LMR-400 / #30M	MAY. 2012 ETC
FILTER	2 LINE, 30A	FIL.COIL	FC-943 / 869	NCR
SPECTRUM ANALYZER	9K-40GHz	R&S	FSP40/ 100093	DEC. 2011 ETC
PRE-AMPLIFIER	1 GHz TO 26.5 GHz	HP	8449B/ 3008A01995	JAN. 2012 ETC
HORN ANTENNA	1 GHz TO 18 GHz	EMCO	3115/ 6881	NOV. 2011 ETC
HORN ANTENNA	18 GHz TO 40 GHz	EMCO	3116/ 00032255	FEB. 2012 ETC
K-TYPE CABLE	15M	HUBER SUHNER	SF 102-40/2*11 /23932/2	MAY. 2012 ETC
K-TYPE CABLE	1M	HUBER SUHNER	SF 102-40/2*11 /23934/2	NOV. 2011 ETC

NOTE:

1. The calibration interval of the above test equipment is one year and the calibrations are traceable to NML/ROC and NIST/USA.



4.2.3 TEST SET-UP 30MHz ~ 1GHz

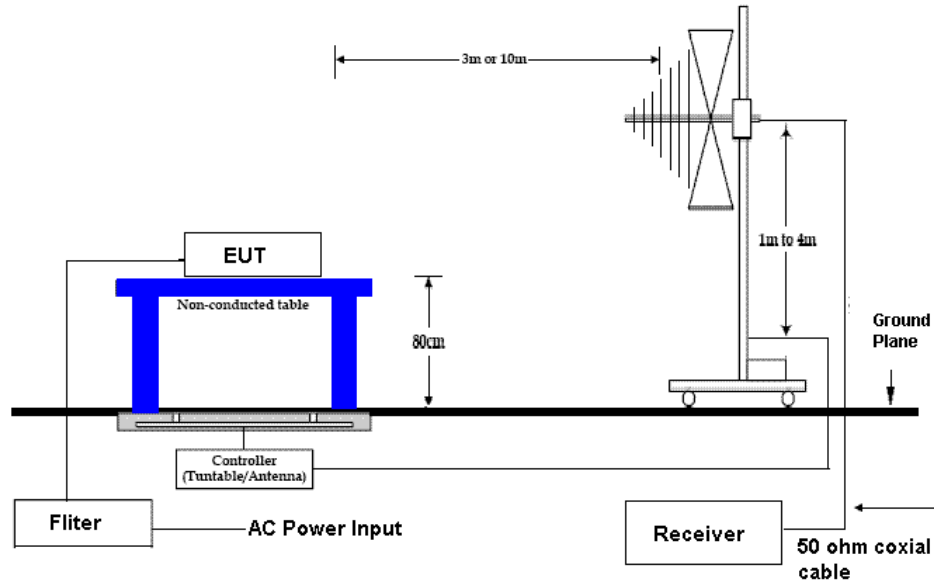

Above 1GHz

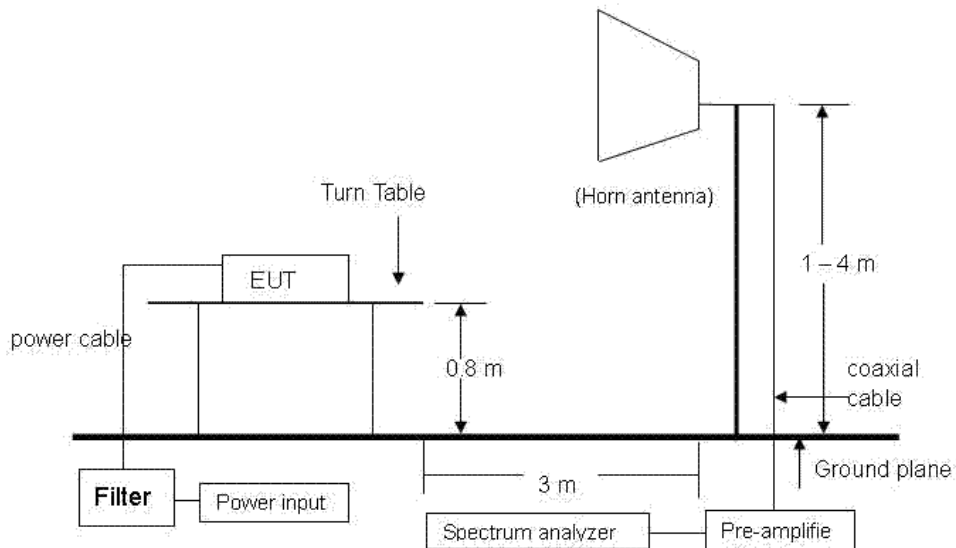

NOTE :

1. The EUT system was put on a wooden table with 0.8m heights above a ground plane. For the actual test configuration, please refer to the photos of testing.



**Spectrum Research &
Testing Lab., Inc.**

No. 101-10, Ling 8,
Shan-Tong Li, Chung-Li
City, Taoyuan, Taiwan

TEST REPORT

Reference No.: A11051302

Report No.: FCC A11051302

FCC ID : ZL7RIDE-SENSE-G1

Page:12 of 20

Date: Jun. 03, 2011

4.2.4 TEST PROCEDURE

The EUT was tested according to the requirement of ANSI C63.4:2003 and CISPR 22:2003. The measurements were made at an open area test site with 3 meter measurement distance under 1 GHz and with 3m distance above 1GHz. The frequency spectrum measured started from 30 MHz. Under 1 GHz, all readings were quasi-peak values with 120 kHz resolution bandwidth of the test receiver. Above 1 GHz, the measurements were made at an open area test site with 3 meter measurement distance and all readings were peak or average values with 1 MHz resolution bandwidth of the test receiver. The EUT system was operated in all typical methods by users. The cables connected to EUT and support units were moved to find the maximum emission levels for each frequency.

First, find the margin or higher points at least 6 points by software, then use manual to find the maximum data. The procedure is referred on the test procedure of SRT LAB.



TEST REPORT

4.2.5 TEST RESULT

Temperature:	28 °C	Humidity:	62 %RH
Tested By:	Richard Lin	Tested Mode:	Tx
Receiver Detector:	Q.P. or AV.	Modulation Type:	GFSK
Frequency Range:	30M – 1GHz	Tested Date:	MAY. 30, 2011

Antenna Polarization : Horizontal

Frequency (MHz)	Cable Loss (dB)	Antenna Factor (dB/m)	Reading Data (dBμV)	Emission Level (dBμV/m)	Limit (dBμV/m)	Margin (dB)	AZ(°)	EL(m)
49.4000	1.09	14.41	13.6	29.1	40.0	-10.9	109	1.84
105.1750	1.45	10.40	15.7	27.6	43.5	-16.0	183	1.75
602.3000	3.51	19.63	8.3	31.4	46.0	-14.6	73	1.62
650.8000	3.70	20.30	5.7	29.7	46.0	-16.3	225	1.53
929.6750	4.56	23.74	7.4	35.7	46.0	-10.3	314	1.49
939.3750	4.58	23.96	5.4	33.9	46.0	-12.1	202	1.42

Antenna Polarization : Vertical

Frequency (MHz)	Cable Loss (dB)	Antenna Factor (dB/m)	Reading Data (dBμV)	Emission Level (dBμV/m)	Limit (dBμV/m)	Margin (dB)	AZ(°)	EL(m)
105.1750	1.45	10.40	17.4	29.3	43.5	-14.3	42	1.46
459.2250	3.04	17.43	7.3	27.8	46.0	-18.2	93	1.52
553.8000	3.41	18.66	5.8	27.9	46.0	-18.1	134	1.66
602.3000	3.51	19.63	5.6	28.7	46.0	-17.3	245	1.72
842.3750	4.27	22.77	3.9	30.9	46.0	-15.1	296	1.83
939.3750	4.58	23.96	3.7	32.2	46.0	-13.8	141	1.89

NOTE :

1. Measurement uncertainty is +/- 4.73dB.
2. "****": Measurement does not apply for this frequency.
3. Emission Level = Reading Value + Ant. Factor + Cable Loss.
4. The field strength of other emission frequencies were very low against the limit.



TEST REPORT

Temperature:	28 °C	Humidity:	62 %RH
Tested By:	Richard Lin	Tested Mode:	Standby
Receiver Detector:	Q.P. or AV.	Modulation Type:	GFSK
Frequency Range:	30M – 1GHz	Tested Date:	MAY. 30, 2011

Antenna Polarization : Horizontal

Frequency (MHz)	Cable Loss (dB)	Antenna Factor (dB/m)	Reading Data (dBμV)	Emission Level (dBμV/m)	Limit (dBμV/m)	Margin (dB)	AZ(°)	EL(m)
80.9250	1.30	8.20	17.7	27.2	40.0	-12.8	236	1.92
102.7500	1.42	10.04	20.7	32.2	43.5	-11.3	142	1.84
313.7250	2.45	14.21	14.9	31.6	46.0	-14.4	327	1.76
459.2250	3.04	17.43	7.3	27.8	46.0	-18.2	41	1.61
650.8000	3.70	20.30	4.8	28.8	46.0	-17.2	96	1.55
939.3750	4.58	23.96	3.7	32.2	46.0	-13.8	164	1.44

Antenna Polarization : Vertical

Frequency (MHz)	Cable Loss (dB)	Antenna Factor (dB/m)	Reading Data (dBμV)	Emission Level (dBμV/m)	Limit (dBμV/m)	Margin (dB)	AZ(°)	EL(m)
49.4000	1.09	14.41	12.7	28.2	40.0	-11.8	217	1.38
90.6250	1.40	8.70	20.6	30.7	43.5	-12.8	113	1.49
170.6500	1.80	11.00	13.3	26.1	43.5	-17.4	309	1.59
650.8000	3.70	20.30	3.6	27.6	46.0	-18.4	68	1.66
842.3750	4.27	22.77	4.8	31.8	46.0	-14.2	121	1.72
929.6750	4.56	23.74	6.1	34.4	46.0	-11.6	32	1.86

NOTE :

1. Measurement uncertainty is +/- 4.73dB.
2. "***": Measurement does not apply for this frequency.
3. Emission Level = Reading Value + Ant. Factor + Cable Loss.
4. The field strength of other emission frequencies were very low against the limit.



TEST REPORT

Temperature:	28 °C	Humidity:	62 %RH
Receiver Detector:	PK. or AV.	Tested Mode:	Tx
Frequency Range:	1 – 25GHz	Modulation Type:	GFSK
Tested By:	Richard Lin	Tested Date:	MAY. 30, 2011

Antenna Polarization : Horizontal

Frequency (MHz)	Correct Factor (dB)	Ant. Factor (dB/m)	Reading Data (dBμV)		Emission Level (dBμV/m)		Limit (dBμV/m)		Margin (dB)		AZ (°)	EL (m)
			PK.	AV.	PK.	AV.	PK.	AV.	PK.	AV.		
2457.00	-22.59	28.21	71.5	61.2	77.1	66.8	114.0	94.0	-36.9	-27.2	69	1.33
1845.75	-24.56	26.64	40.6	30.1	42.7	32.2	74.0	54.0	-31.3	-21.8	103	1.63
2160.25	-23.47	27.55	38.5	28.3	42.6	32.4	74.0	54.0	-31.4	-21.6	57	1.54
2300.50	-23.05	27.86	37.7	27.9	42.5	32.7	74.0	54.0	-31.5	-21.3	319	1.42
2445.00	-22.62	28.18	45.7	35.5	51.3	41.1	74.0	54.0	-22.7	-12.9	344	1.38
2559.75	-22.32	28.51	35.9	25.4	42.1	31.6	74.0	54.0	-31.9	-22.4	126	1.32
4914.00	-16.59	33.25	34.8	24.5	51.5	41.2	74.0	54.0	-22.5	-12.8	144	1.84
7371.00	-12.61	36.16	41.8	28.1	65.4	51.7	74.0	54.0	-8.6	-2.3	283	1.76

Antenna Polarization : Vertical

Frequency (MHz)	Correct Factor (dB)	Ant. Factor (dB/m)	Reading Data (dBμV)		Emission Level (dBμV/m)		Limit (dBμV/m)		Margin (dB)		AZ (°)	EL (m)
			PK.	AV.	PK.	AV.	PK.	AV.	PK.	AV.		
2457.00	-22.59	28.21	70.1	60.3	75.7	65.9	114.0	94.0	-38.3	-28.1	93	1.91
1850.00	-24.54	26.66	40.9	30.5	43.0	32.6	74.0	54.0	-31.0	-21.4	217	1.64
2377.00	-22.82	28.03	37.2	27.6	42.4	32.8	74.0	54.0	-31.6	-21.2	111	1.73
2436.50	-22.65	28.16	48.8	38.4	54.3	43.9	74.0	54.0	-19.7	-10.1	28	1.81
2559.75	-22.32	28.51	36.2	26.5	42.4	32.7	74.0	54.0	-31.6	-21.3	96	1.89
2644.75	-22.12	28.82	36.2	26.1	42.9	32.8	74.0	54.0	-31.1	-21.2	145	1.92
4914.00	-16.59	33.25	35.4	25.6	52.1	42.3	74.0	54.0	-21.9	-11.7	125	1.45
7371.00	-12.61	36.16	41.6	27.5	65.2	51.1	74.0	54.0	-8.8	-2.9	39	1.52

NOTE :

1. Measurement uncertainty is +/- 4.73dB.
2. "": The Peak reading value also meets average limit and measurement with the average detector is unnecessary.
3. Emission Level = Reading Value + Ant. Factor + Correct Factor (incl.:Cable Loss and Pre-Amplifier Gain)
4. The field strength of other emission frequencies were very low against the limit.
5. (F):The field strength of fundamental frequency.



TEST REPORT

Temperature:	28 °C	Humidity:	62 %RH
Receiver Detector:	PK. or AV.	Tested Mode:	Standby
Frequency Range:	1 – 25GHz	Modulation Type:	GFSK
Tested By:	Richard Lin	Tested Date:	MAY. 30, 2011

Antenna Polarization : Horizontal

Frequency (MHz)	Correct Factor (dB)	Ant. Factor (dB/m)	Reading Data (dB μ V)		Emission Level (dB μ V/m)		Limit (dB μ V/m)		Margin (dB)		AZ (°)	EL (m)
			PK.	AV.	PK.	AV.	PK.	AV.	PK.	AV.		
2457.00	-22.59	28.21	37.9	27.4	43.5	33.0	74.0	54.0	-30.5	-21.0	212	1.23
1824.50	-24.64	26.57	43.7	33.5	45.6	35.4	74.0	54.0	-28.4	-18.6	159	1.57
2326.00	-22.98	27.92	38.4	28.6	43.3	33.6	74.0	54.0	-30.7	-20.4	62	1.38
2415.25	-22.71	28.11	48.5	38.4	53.9	43.8	74.0	54.0	-20.1	-10.2	123	1.32
2449.25	-22.61	28.19	52.9	42.0	58.5	47.5	74.0	54.0	-15.5	-6.5	258	1.25
2585.25	-22.26	28.61	37.5	27.5	43.8	33.8	74.0	54.0	-30.2	-20.2	95	1.16
4914.00	-16.59	33.25	35.5	25.4	52.2	42.1	74.0	54.0	-21.8	-11.9	152	1.14
7371.00	-12.61	36.16	39.8	27.1	63.4	50.7	74.0	54.0	-10.6	-3.3	187	1.11

Antenna Polarization : Vertical

Frequency (MHz)	Correct Factor (dB)	Ant. Factor (dB/m)	Reading Data (dB μ V)		Emission Level (dB μ V/m)		Limit (dB μ V/m)		Margin (dB)		AZ (°)	EL (m)
			PK.	AV.	PK.	AV.	PK.	AV.	PK.	AV.		
2457.00	-22.59	28.21	35.7	25.9	41.3	31.5	74.0	54.0	-32.7	-22.5	184	1.76
2419.50	-22.70	28.12	51.1	41.3	56.5	46.7	74.0	54.0	-17.5	-7.3	257	1.45
2436.50	-22.65	28.16	53.1	43.1	58.6	48.6	74.0	54.0	-15.4	-5.4	319	1.55
2449.25	-22.61	28.19	48.6	38.6	54.2	44.1	74.0	54.0	-19.8	-9.9	267	1.62
2462.00	-22.57	28.22	48.1	38.2	53.7	43.9	74.0	54.0	-20.3	-10.1	105	1.73
2572.00	-22.29	28.56	36.4	26.3	42.7	32.6	74.0	54.0	-31.3	-21.4	204	1.78
4914.00	-16.59	33.25	34.5	24.5	51.2	41.2	74.0	54.0	-22.8	-12.8	136	1.79
7371.00	-12.61	36.16	41.1	27.4	64.7	51.0	74.0	54.0	-9.3	-3.0	184	1.82

NOTE :

1. Measurement uncertainty is +/- 4.73dB.
2. "": The Peak reading value also meets average limit and measurement with the average detector is unnecessary.
3. Emission Level = Reading Value + Ant. Factor + Correct Factor (incl.:Cable Loss and Pre-Amplifier Gain)
4. The field strength of other emission frequencies were very low against the limit.
5. (F):The field strength of fundamental frequency.



**Spectrum Research &
Testing Lab., Inc.**
No. 101-10, Ling 8,
Shan-Tong Li, Chung-Li
City, Taoyuan, Taiwan

TEST REPORT

Reference No.: A11051302
Report No.: FCC A11051302
FCC ID : ZL7RIDE-SENSE-G1
Page:17 of 20
Date: Jun. 03, 2011

5. Antenna application

5.1 Antenna requirement

The EUT's antenna is met the requirement of FCC part15C section15.203 and 15.204.

5.2 Result

The EUT's antenna used a Chip Antenna. Gain of antenna types is 2 dBi that meet the requirement.



6. PHOTOS OF TESTING

- Radiated test (below 1G , TX & Standby)





Spectrum Research & Testing Lab., Inc.
No. 101-10, Ling 8,
Shan-Tong Li, Chung-Li
City, Taoyuan, Taiwan

TEST REPORT

Reference No.: A11051302
Report No.: FCC A11051302
FCC ID : ZL7RIDE-SENSE-G1
Page:19 of 20
Date: Jun. 03, 2011

- Radiated test (above 1G , TX & Standby)





Spectrum Research & Testing Lab., Inc.
No. 101-10, Ling 8,
Shan-Tong Li, Chung-Li
City, Taoyuan, Taiwan

TEST REPORT

Reference No.: A11051302
Report No.: FCC A11051302
FCC ID : ZL7RIDE-SENSE-G1
Page:20 of 20
Date: Jun. 03, 2011

7. TERMS OF ABBREVIATION

AV.	Average detection
AZ(°)	Turn table azimuth
Correct.	Correction
EL(m)	Antenna height (meter)
EUT	Equipment Under Test
Horiz.	Horizontal direction
LISN	Line Impedance Stabilization Network
NSA	Normalized Site Attenuation
Q.P.	Quasi-peak detection
SRT Lab	Spectrum Research & Testing Laboratory, Inc.
Vert.	Vertical direction