

HAC_E_Dipole_835

DUT: HAC-Dipole 835 MHz

Communication System: CW; Frequency: 835 MHz; Duty Cycle: 1:1

Medium: Air Medium parameters used: $\sigma = 0$ S/m, $\epsilon_r = 1$; $\rho = 0$ kg/m³

Ambient Temperature : 23.4 °C

DASY5 Configuration

- Probe: ER3DV6 - SN2358; ConvF(1, 1, 1); Calibrated: 2018/1/19;
- Sensor-Surface: (Fix Surface)
- Electronics: DAE4 Sn854; Calibrated: 2017/5/2
- Phantom: HAC Test Arch with AMCC; Type: SD HAC P01 BA;
- Measurement SW: DASY52, Version 52.8 (8); SEMCAD X Version 14.6.10 (7373)

E Scan - measurement distance from the probe sensor center to CD835 = 10mm & 15mm/Hearing Aid Compatibility Test at 15mm distance (41x361x1): Interpolated grid:

dx=0.5000 mm, dy=0.5000 mm

Device Reference Point: 0, 0, -6.3 mm

Reference Value = 131.7 V/m; Power Drift = -0.02 dB

PMR not calibrated. PMF = 1.000 is applied.

E-field emissions = 116.4 V/m

Average value of Total=(116.4+116) / 2 = 116.2 V/m

PMF scaled E-field

Grid 1 M4 115.8 V/m	Grid 2 M4 116.4 V/m	Grid 3 M4 113.0 V/m
Grid 4 M4 64.49 V/m	Grid 5 M4 65.95 V/m	Grid 6 M4 65.22 V/m
Grid 7 M4 112.9 V/m	Grid 8 M4 116.0 V/m	Grid 9 M4 114.7 V/m

Cursor:

Total = 116.4 V/m

E Category: M4

Location: 1.5, -75, 9.7 mm

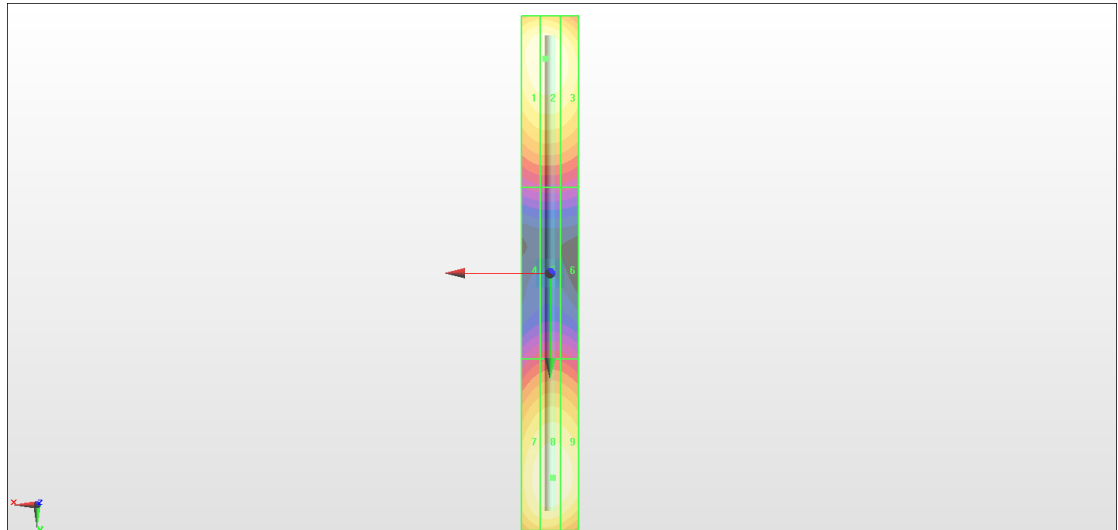
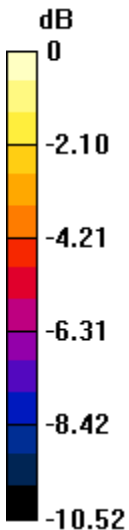

0 dB = 116.4 V/m = 41.32 dBV/m

HAC_E_Dipole_1880

DUT: HAC Dipole 1880 MHz

Communication System: CW; Frequency: 1880 MHz; Duty Cycle: 1:1

Medium: Air Medium parameters used: $\sigma = 0$ S/m, $\epsilon_r = 1$; $\rho = 0$ kg/m³

Ambient Temperature : 23.4 °C

DASY5 Configuration

- Probe: ER3DV6 - SN2358; ConvF(1, 1, 1); Calibrated: 2018/1/19;
- Sensor-Surface: (Fix Surface)
- Electronics: DAE4 Sn854; Calibrated: 2017/5/2
- Phantom: HAC Test Arch with AMCC; Type: SD HAC P01 BA;
- Measurement SW: DASY52, Version 52.8 (8); SEMCAD X Version 14.6.10 (7373)

E Scan - measurement distance from the probe sensor center to CD1880 = 10mm & 15mm/Hearing Aid Compatibility Test at 15mm distance (41x181x1): Interpolated grid:

dx=0.5000 mm, dy=0.5000 mm

Device Reference Point: 0, 0, -6.3 mm

Reference Value = 146.4 V/m; Power Drift = 0.02 dB

PMR not calibrated. PMF = 1.000 is applied.

E-field emissions = 92.71 V/m

Average value of Total=(89.02+92.71) / 2 = 90.865 V/m

PMF scaled E-field

Grid 1 M3 88.74 V/m	Grid 2 M3 89.02 V/m	Grid 3 M3 86.12 V/m
Grid 4 M3 70.59 V/m	Grid 5 M3 71.51 V/m	Grid 6 M3 70.47 V/m
Grid 7 M3 91.47 V/m	Grid 8 M3 92.71 V/m	Grid 9 M3 90.61 V/m

Cursor:

Total = 92.71 V/m

E Category: M3

Location: 0.5, 32, 9.7 mm

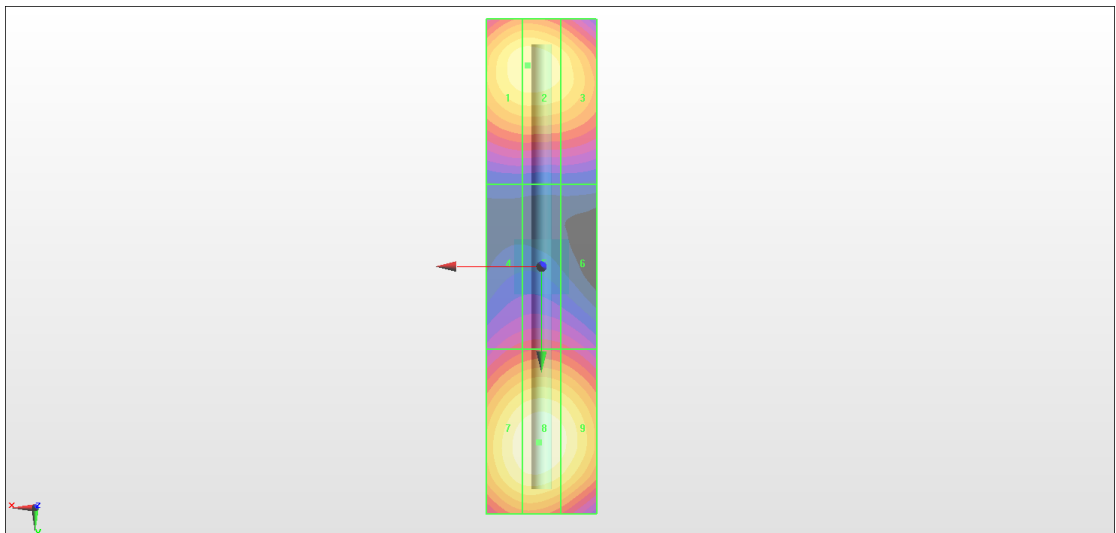
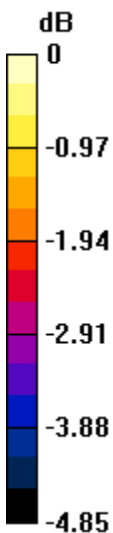

0 dB = 92.71 V/m = 39.34 dBV/m