



# FCC RF Test Report

**APPLICANT** : Bullitt Group  
**EQUIPMENT** : Rugged Smart Phone  
**BRAND NAME** : CAT  
**MODEL NAME** : S50  
**FCC ID** : ZL5S50  
**STANDARD** : FCC Part 15 Subpart C §15.247  
**CLASSIFICATION** : (DTS) Digital Transmission System

The product was received on Jun. 30, 2014 and testing was completed on Aug. 01, 2014. We, SPORTON INTERNATIONAL INC., would like to declare that the tested sample has been evaluated in accordance with the test procedures and has been in compliance with the applicable technical standards.

The test results in this report apply exclusively to the tested model / sample. Without written approval of SPORTON INTERNATIONAL INC., the test report shall not be reproduced except in full.

Reviewed by: Joseph Lin / Supervisor

Approved by: Jones Tsai / Manager



## **SPORTON INTERNATIONAL INC.**

No. 52, Hwa Ya 1<sup>st</sup> Rd., Hwa Ya Technology Park, Kwei-Shan Hsiang, Tao Yuan Hsien, Taiwan, R.O.C.



# TABLE OF CONTENTS

**REVISION HISTORY..... 3**

**SUMMARY OF TEST RESULT ..... 4**

**1 GENERAL DESCRIPTION..... 5**

    1.1 Applicant..... 5

    1.2 Manufacturer..... 5

    1.3 Product Feature of Equipment Under Test..... 5

    1.4 Product Specification subjective to this standard ..... 5

    1.5 Modification of EUT ..... 6

    1.6 Testing Location ..... 6

    1.7 Applicable Standards..... 6

**2 TEST CONFIGURATION OF EQUIPMENT UNDER TEST..... 7**

    2.1 Descriptions of Test Mode ..... 7

    2.2 Test Mode..... 8

    2.3 Connection Diagram of Test System..... 9

    2.4 Support Unit used in test configuration and system ..... 10

    2.5 EUT Operation Test Setup ..... 11

    2.6 Measurement Results Explanation Example..... 11

**3 TEST RESULT ..... 12**

    3.1 6dB and 99% Bandwidth Measurement ..... 12

    3.2 Peak Output Power Measurement ..... 17

    3.3 Power Spectral Density Measurement ..... 19

    3.4 Conducted Band Edges and Spurious Emission Measurement ..... 25

    3.5 Radiated Band Edges and Spurious Emission Measurement ..... 34

    3.6 AC Conducted Emission Measurement..... 46

    3.7 Antenna Requirements..... 50

**4 LIST OF MEASURING EQUIPMENT..... 51**

**5 UNCERTAINTY OF EVALUATION..... 52**

**APPENDIX A. SETUP PHOTOGRAPHS**



### REVISION HISTORY

REPORT NO.	VERSION	DESCRIPTION	ISSUED DATE
FR463004B	Rev. 01	Initial issue of report	Aug. 19, 2014



### SUMMARY OF TEST RESULT

Report Section	FCC Rule	IC Rule	Description	Limit	Result	Remark
3.1	15.247(a)(2)	RSS-210 A8.2(a)	6dB Bandwidth	≥ 0.5MHz	Pass	-
3.1	-	RSS-Gen 4.6.1	99% Bandwidth	-	Pass	-
3.2	15.247(b)(1)	RSS-210 A8.1(b)	Peak Output Power	≤ 30dBm	Pass	-
3.3	15.247(e)	RSS-210 A8.2(b)	Power Spectral Density	≤ 8dBm/3kHz	Pass	-
3.4	15.247(d)	RSS-210 A8.5	Conducted Band Edges and Spurious Emission	≤ 20dBc	Pass	-
3.5	15.247(d)	RSS-210 A8.5	Radiated Band Edges and Spurious Emission	15.209(a) & 15.247(d)	Pass	Under limit 12.99 dB at 70.230 MHz
3.6	15.207	RSS-Gen 7.2.4	AC Conducted Emission	15.207(a)	Pass	Under limit 6.80 dB at 0.190 MHz
3.7	15.203 & 15.247(b)	RSS-210 A8.4	Antenna Requirement	N/A	Pass	-



# 1 General Description

## 1.1 Applicant

**Bullitt Group**

No. 4, The Aquarium, King Street, Reading, RG1 2AN United Kingdom

## 1.2 Manufacturer

**Compal Electronics, INC.**

No. 385, Yangguang St. Neihu District, Taipei City 11491, Taiwan, R.O.C

## 1.3 Product Feature of Equipment Under Test

Product Feature	
Equipment	Rugged Smart Phone
Brand Name	CAT
Model Name	S50
FCC ID	ZL5S50
EUT supports Radios application	GSM/EGPRS/WCDMA/HSPA/LTE/NFC WLAN 11b/g/n HT20 WLAN 11a/n HT20/HT40 Bluetooth v4.0 EDR/LE
HW Version	DVT1
SW Version	LTE_S0201121.0_S50_0.006.00
EUT Stage	Identical Prototype

**Remark:** The above EUT's information was declared by manufacturer. Please refer to the specifications or user's manual for more detailed description.

## 1.4 Product Specification subjective to this standard

Product Specification subjective to this standard	
Tx/Rx Frequency Range	2402 MHz ~ 2480 MHz
Number of Channels	40
Carrier Frequency of Each Channel	40 Channel(37 hopping + 3 advertising channel)
Maximum Output Power to Antenna	2.23 dBm (0.0017 W)
99% Occupied Bandwidth	1.06MHz
Antenna Type	PIFA Antenna type with gain 1.73 dBi
Type of Modulation	Bluetooth LE : GFSK



### 1.5 Modification of EUT

No modifications are made to the EUT during all test items.

### 1.6 Testing Location

Sporton Lab is accredited to ISO 17025 by Taiwan Accreditation Foundation (TAF code : 1190) and the FCC designation No. TW1022 under the FCC 2.948(e) by Mutual Recognition Agreement (MRA) in FCC Test.

<b>Test Site</b>	SPORTON INTERNATIONAL INC.		
<b>Test Site Location</b>	No. 52, Hwa Ya 1 <sup>st</sup> Rd., Hwa Ya Technology Park, Kwei-Shan Hsiang, Tao Yuan Hsien, Taiwan, R.O.C. TEL: +886-3-3273456 / FAX: +886-3-3284978		
<b>Test Site No.</b>	<b>Sporton Site No.</b>		
	TH02-HY	CO05-HY	03CH07-HY

### 1.7 Applicable Standards

According to the specifications of the manufacturer, the EUT must comply with the requirements of the following standards:

- FCC Part 15 Subpart C §15.247
- FCC KDB Publication No. 558074 D01 DTS Meas. Guidance v03r02
- ANSI C63.4-2003

**Remark:**

1. All test items were verified and recorded according to the standards and without any deviation during the test.
2. This EUT has also been tested and complied with the requirements of FCC Part 15, Subpart B, recorded in a separate test report.



## 2 Test Configuration of Equipment Under Test

### 2.1 Descriptions of Test Mode

The RF output power was recorded in the following table:

Channel	Frequency	Bluetooth 4.0 – LE RF Output Power	
		Data Rate / Modulation	
		GFSK	
		1Mbps	
Ch00	2402MHz	1.16 dBm	
Ch19	2440MHz	2.23 dBm	
Ch39	2480MHz	1.10 dBm	

- a. The EUT has been associated with peripherals and configuration operated in a manner tended to maximize its emission characteristics in a typical application. Frequency range investigated: conduction (150 kHz to 30 MHz), radiation (9 kHz to the 10th harmonic of the highest fundamental frequency or to 40 GHz, whichever is lower). Pre-scanned tests, X, Y, Z in three orthogonal panels to determine the final configuration (X plane as worst plane) from all possible combinations.
  
- b. AC power line Conducted Emission was tested under maximum output power.



## 2.2 Test Mode

The following summary table is showing all test modes to demonstrate in compliance with the standard.

Summary table of Test Cases	
Test Item	Data Rate / Modulation
	Bluetooth 4.0 – LE / GFSK
Conducted TCs	Mode 1: Bluetooth Tx CH00_2402 MHz_1Mbps Mode 2: Bluetooth Tx CH19_2440 MHz_1Mbps Mode 3: Bluetooth Tx CH39_2480 MHz_1Mbps
Radiated TCs	Mode 1: Bluetooth Tx CH00_2402 MHz_1Mbps Mode 2: Bluetooth Tx CH19_2440 MHz_1Mbps Mode 3: Bluetooth Tx CH39_2480 MHz_1Mbps Mode 4: Bluetooth Tx CH39_2480 MHz_1Mbps with WPC
AC Conducted Emission	Mode 1: GSM1900 Idle + WLAN Link + Bluetooth Link + Earphone + USB Cable (Data Link with Notebook) + GPS Rx + Battery



## 2.3 Connection Diagram of Test System

<Bluetooth 4.0 – LE Tx Mode>

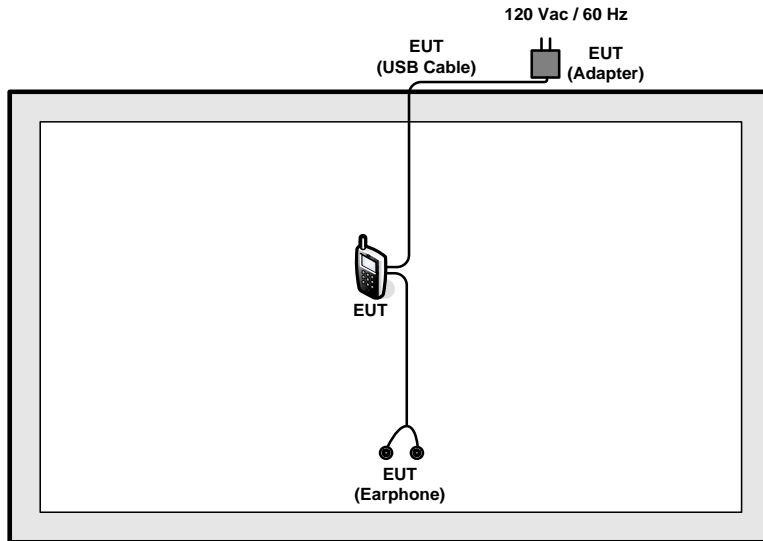

< WLAN Tx Mode with WPC Charging >

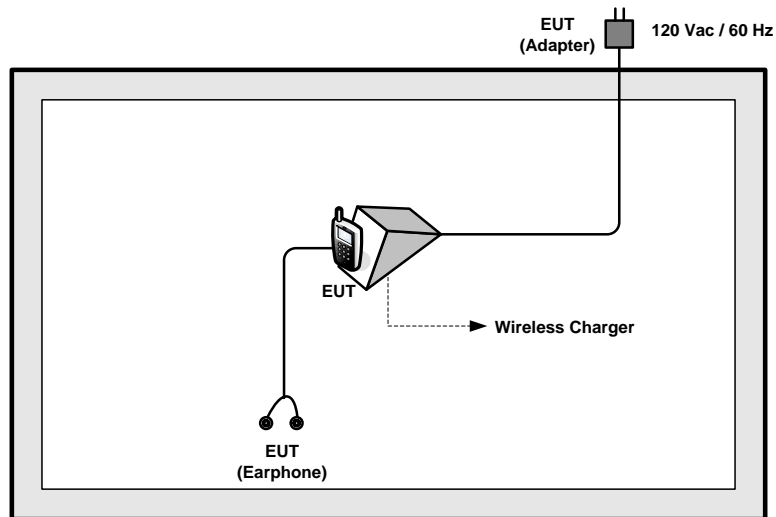

<AC Conducted Emission Mode>

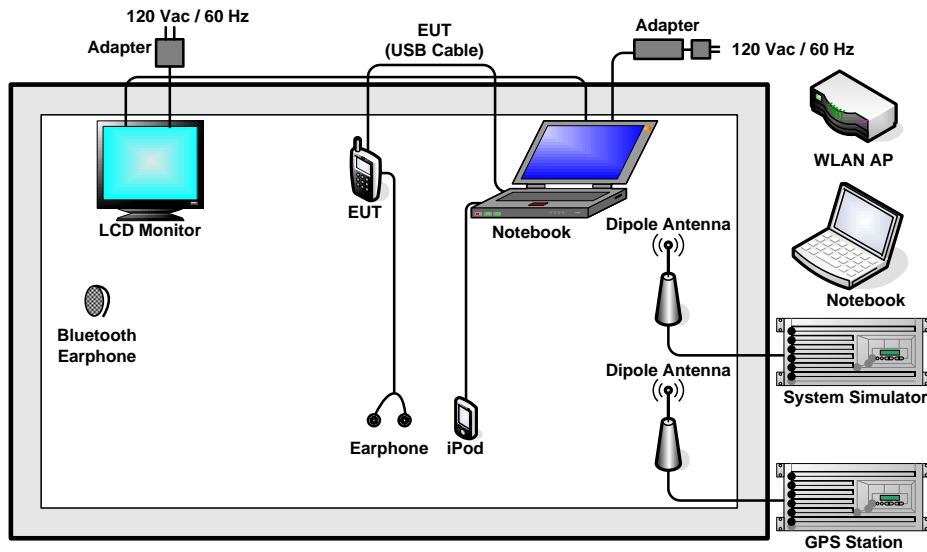

2.4 Support Unit used in test configuration and system

Item	Equipment	Trade Name	Model Name	FCC ID	Data Cable	Power Cord
1.	System Simulator	R&S	CMU 200	N/A	N/A	Unshielded, 1.8 m
2.	GPS Station	Pendulum	GSG-54	N/A	N/A	Unshielded, 1.8 m
3.	Bluetooth Earphone	Sony Ericsson	MW600	PY7DDA-2029	N/A	N/A
4.	WLAN AP	D-Link	DIR-628	KA2DIR628A2	N/A	Unshielded, 1.8 m
5.	Notebook	DELL	Latitude E6320	FCC DoC/ Contains FCC ID: QDS-BRCM1054	N/A	AC I/P: Unshielded, 1.2 m DC O/P: Shielded, 1.8 m
6.	iPod	Apple	A1285	FCC DoC	Shielded, 1.0 m	N/A
7.	LCD Monitor	DELL	U2410	FCC DoC	Shielded, 1.6 m	Unshielded, 1.8 m
8.	SD Card	SanDisk	MicroSD HC	FCC DoC	N/A	N/A



## 2.5 EUT Operation Test Setup

For Bluetooth function, programmed RF utility, "QRCT" installed in the notebook make the EUT provide functions like channel selection and power level for continuous transmitting and receiving signals.

## 2.6 Measurement Results Explanation Example

**For all conducted test items:**

The offset level is set in the spectrum analyzer to compensate the RF cable loss and attenuator factor between EUT conducted output port and spectrum analyzer. With the offset compensation, the spectrum analyzer reading level is exactly the EUT RF output level.

Example :

The spectrum analyzer offset is derived from RF cable loss and attenuator factor.

*Offset = RF cable loss + attenuator factor.*

Following shows an offset computation example with cable loss 4.2 dB and 10dB attenuator.

$$\begin{aligned} \text{Offset(dB)} &= \text{RF cable loss(dB)} + \text{attenuator factor(dB)}. \\ &= 4.2 + 10 = 14.2 \text{ (dB)} \end{aligned}$$

### 3 Test Result

#### 3.1 6dB and 99% Bandwidth Measurement

##### 3.1.1 Limit of 6dB and 99% Bandwidth

The minimum 6 dB bandwidth shall be at least 500 kHz.

##### 3.1.2 Measuring Instruments

The section 4.0 of List of Measuring Equipment of this test report is used for test.

##### 3.1.3 Test Procedures

1. The testing follows FCC KDB Publication No. 558074 D01 DTS Meas. Guidance v03r02.
2. The RF output of EUT was connected to the spectrum analyzer by RF cable and attenuator. The path loss was compensated to the results for each measurement.
3. Set to the maximum power setting and enable the EUT transmit continuously.
4. Make the measurement with the spectrum analyzer's resolution bandwidth (RBW) = 100 kHz. Set the Video bandwidth (VBW) = 300 kHz. In order to make an accurate measurement. The 6 dB bandwidth must be greater than 500 kHz.
5. For 99% Bandwidth Measurement, the spectrum analyzer's resolution bandwidth (RBW) is set 30kHz and set the Video bandwidth (VBW) = 100kHz.
6. Measure and record the results in the test report.

##### 3.1.4 Test Setup





3.1.5 Test Result of 6dB Bandwidth

Test Mode :	Bluetooth 4.0 - LE	Temperature :	22~25°C
Test Engineer :	Osolemio Chang	Relative Humidity :	51~55%

Channel	Frequency (MHz)	6dB Bandwidth (MHz)	6dB Bandwidth Min. Limit (MHz)	Pass/Fail
00	2402	0.67	0.5	Pass
19	2440	0.66	0.5	Pass
39	2480	0.67	0.5	Pass

6 dB Bandwidth Plot on Channel 00

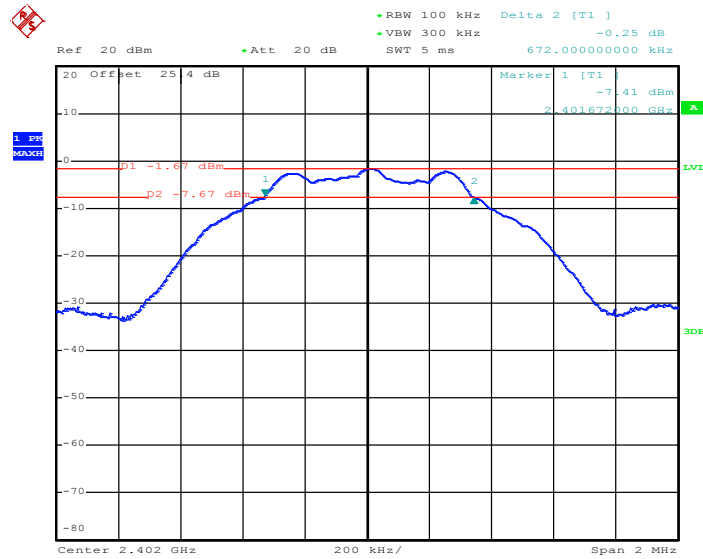

Date: 1.AUG.2014 05:04:12



### 6 dB Bandwidth Plot on Channel 19

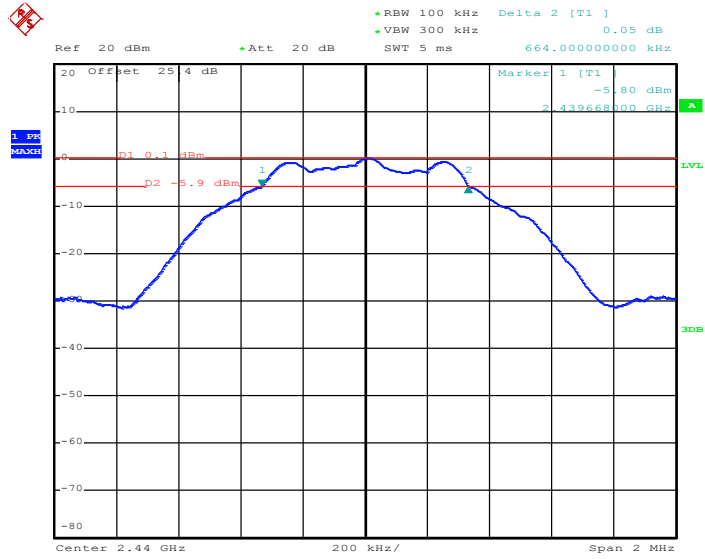

Date: 1.AUG.2014 05:08:41

### 6 dB Bandwidth Plot on Channel 39

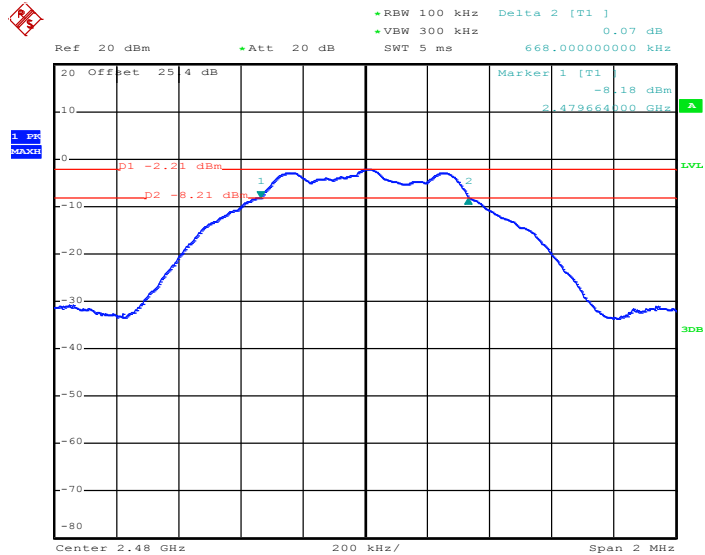

Date: 1.AUG.2014 05:12:44



3.1.6 Test Result of 99% Occupied Bandwidth

Test Mode :	Bluetooth 4.0 - LE	Temperature :	22~25°C
Test Engineer :	Osolemio Chang	Relative Humidity :	51~55%

Channel	Frequency (MHz)	99% Occupied Bandwidth (MHz)
00	2402	1.06
19	2440	1.06
39	2480	1.06

99% Bandwidth Plot on Channel 00

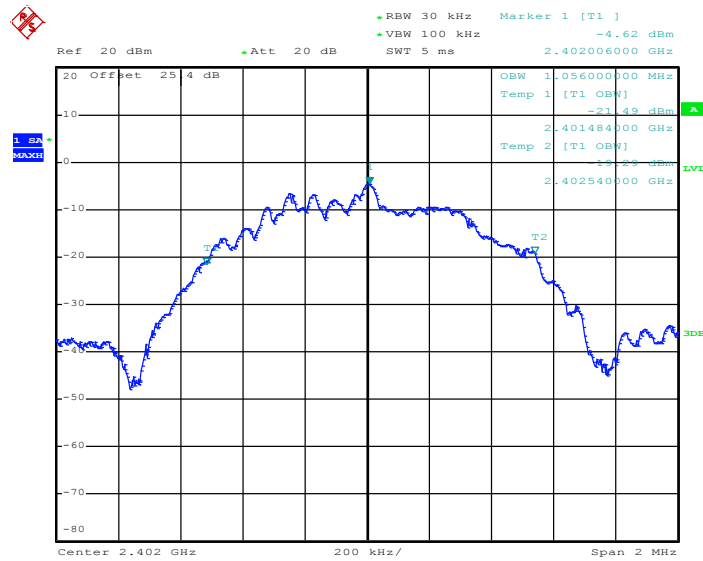

Date: 1.AUG.2014 05:06:33



99% Occupied Bandwidth Plot on Channel 19

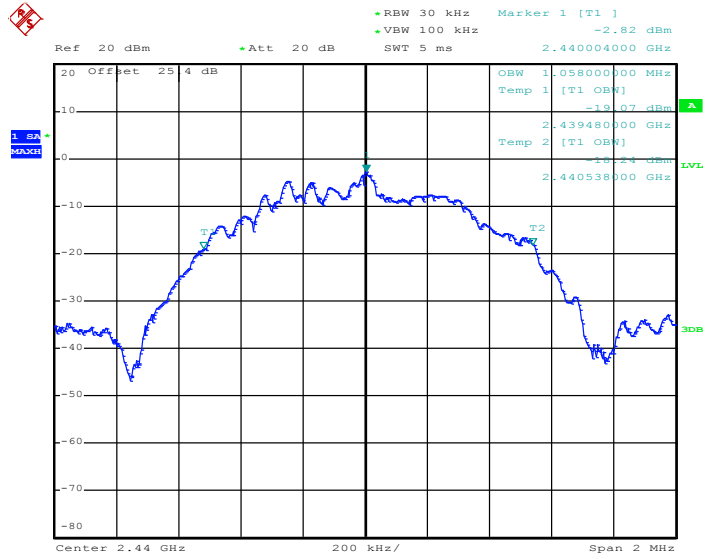

Date: 1.AUG.2014 05:11:05

99% Occupied Bandwidth Plot on Channel 39

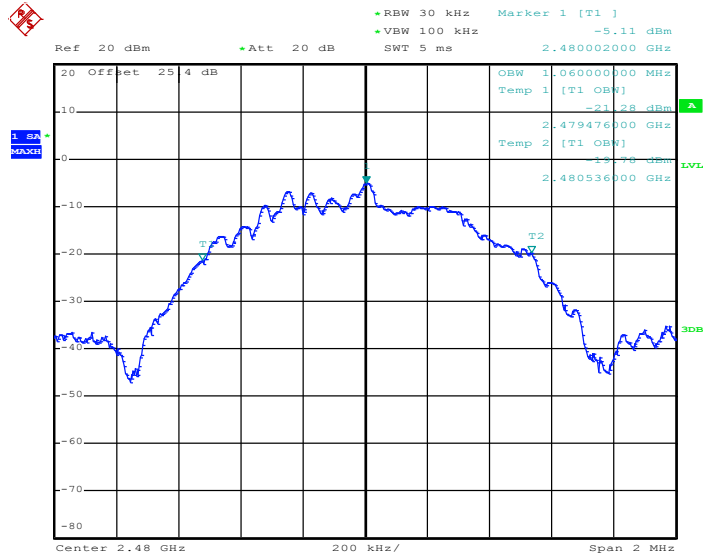

Date: 1.AUG.2014 05:14:50

Note : The occupied channel bandwidth is maintained within the band of operation for all of the modulations.



## 3.2 Peak Output Power Measurement

### 3.2.1 Limit of Peak Output Power

For systems using digital modulation in the 2400-2483.5MHz, the limit for peak output power is 30dBm. If transmitting antenna of directional gain greater than 6dBi is used, the peak output power from the intentional radiator shall be reduced below the above stated value by the amount in dB that the directional gain of the antenna exceeds 6 dBi. In case of point-to-point operation, the limit has to be reduced by 1dB for every 3dB that the directional gain of the antenna exceeds 6dBi.

### 3.2.2 Measuring Instruments

The section 4.0 of List of Measuring Equipment of this test report is used for test.

### 3.2.3 Test Procedures

1. The testing follows the Measurement Procedure of FCC KDB No. 558074 DTS D01 Meas. Guidance v03r02.
2. The RF output of EUT was connected to the power meter by RF cable and attenuator. The path loss was compensated to the results for each measurement.
3. Set to the maximum power setting and enable the EUT transmit continuously.
4. Measure the conducted output power and record the results in the test report.

### 3.2.4 Test Setup

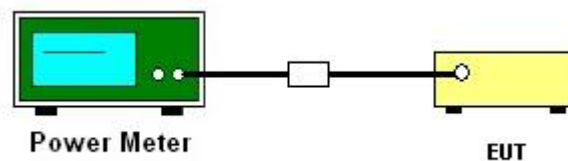



3.2.5 Test Result of Peak Output Power

Test Mode :	Bluetooth 4.0 - LE	Temperature :	22~25°C
Test Engineer :	Osolemio Chang	Relative Humidity :	51~55%

Channel	Frequency (MHz)	RF Power (dBm)		
		GFSK	Max. Limits (dBm)	Pass/Fail
		1 Mbps		
00	2402	1.16	30.00	Pass
19	2440	2.23	30.00	Pass
39	2480	1.10	30.00	Pass

### 3.3 Power Spectral Density Measurement

#### 3.3.1 Limit of Power Spectral Density

The peak power spectral density shall not be greater than 8dBm in any 3kHz band at any time interval of continuous transmission.

#### 3.3.2 Measuring Instruments

The section 4.0 of List of Measuring Equipment of this test report is used for test.

#### 3.3.3 Test Procedures

1. The testing follows Measurement Procedure 10.2 Method PKPSD of FCC KDB Publication No. 558074 D01 DTS Meas. Guidance v03r02
2. The RF output of EUT was connected to the spectrum analyzer by RF cable and attenuator. The path loss was compensated to the results for each measurement.
3. Set to the maximum power setting and enable the EUT transmit continuously.
4. Make the measurement with the spectrum analyzer's resolution bandwidth (RBW) = 3 kHz. Video bandwidth VBW = 10 kHz In order to make an accurate measurement, set the span to 1.5 times DTS Channel Bandwidth. (6dB BW)
5. Detector = peak, Sweep time = auto couple, Trace mode = max hold, Allow trace to fully stabilize. Use the peak marker function to determine the maximum power level.
6. Measure and record the results in the test report.
7. The Measured power density (dBm)/ 100kHz is a reference level and used as 20dBc down limit line for Conducted Band Edges and Conducted Spurious Emission.

#### 3.3.4 Test Setup

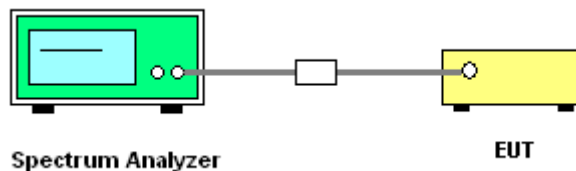



### 3.3.5 Test Result of Power Spectral Density

Test Mode :	Bluetooth 4.0 - LE	Temperature :	22~25°C
Test Engineer :	Osolemio Chang	Relative Humidity :	51~55%

Channel	Frequency (MHz)	Power Density		Max. Limits (dBm/3kHz)	Pass/Fail
		PSD/100kHz (dBm)	PSD/3kHz (dBm)		
00	2402	-1.67	-16.89	8	Pass
19	2440	0.09	-15.13	8	Pass
39	2480	-2.21	-17.36	8	Pass

**Note:**

1. Measured power density (dBm) has offset with cable loss.
2. The Measured power density (dBm)/ 100kHz is reference level and used as 20dBc down for Conducted Band Edges and Conducted Spurious Emission limit line.



### 3.3.6 Test Result of Power Spectral Density Plots (100kHz)

PSD 100kHz Plot on Channel 00

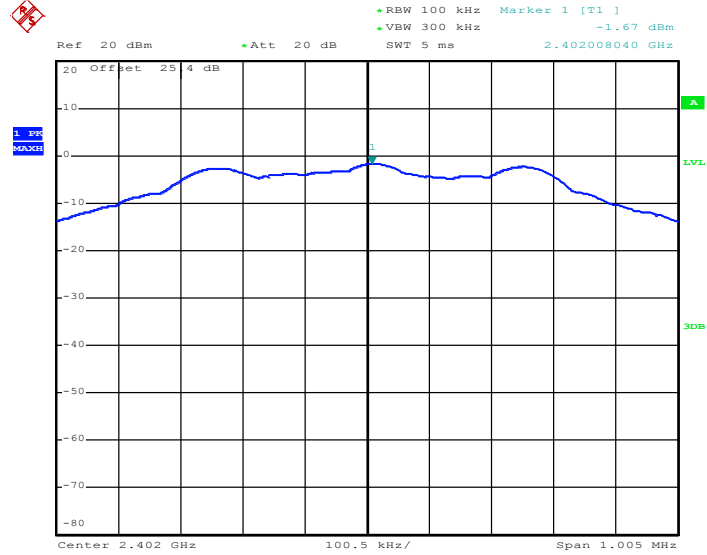

Date: 1.AUG.2014 05:04:58



PSD 100kHz Plot on Channel 19

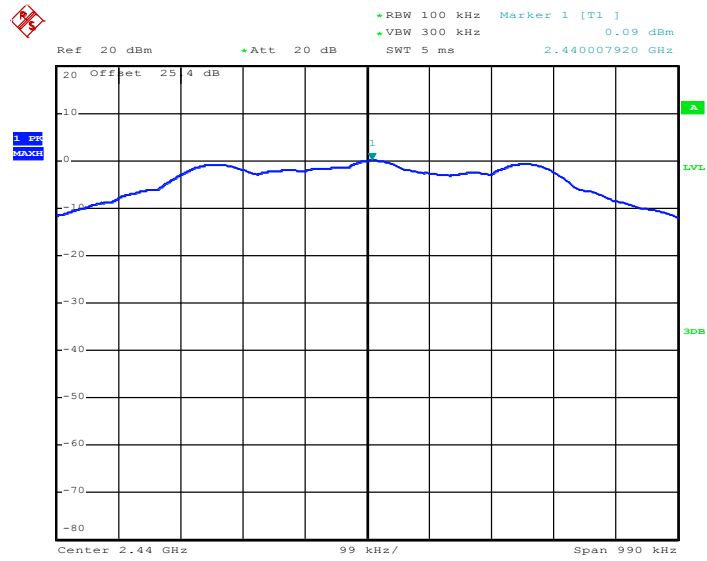

Date: 1.AUG.2014 05:09:32

PSD 100kHz Plot on Channel 39

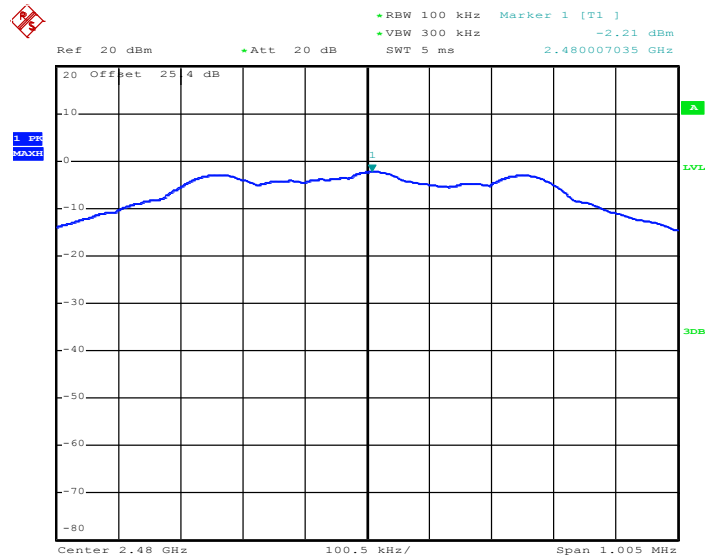

Date: 1.AUG.2014 05:13:31



### 3.3.7 Test Result of Power Spectral Density Plots (3kHz)

PSD 3kHz Plot on Channel 00

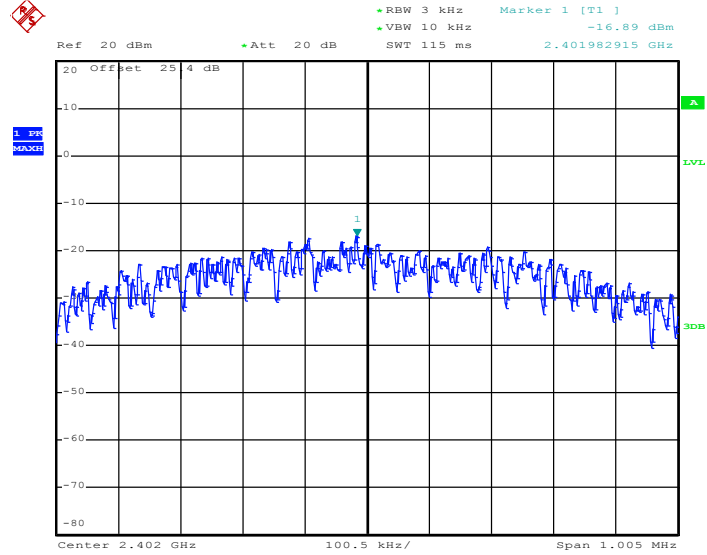

Date: 1.AUG.2014 05:04:36



PSD 3kHz Plot on Channel 19

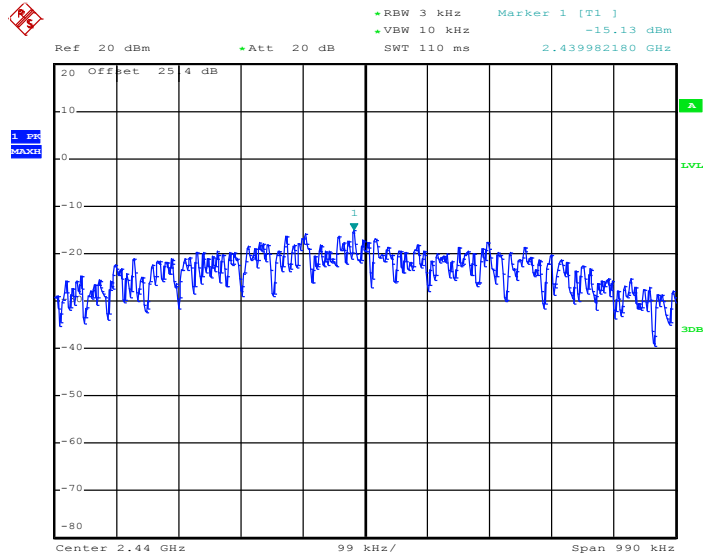

Date: 1.AUG.2014 05:09:05

PSD 3kHz Plot on Channel 39

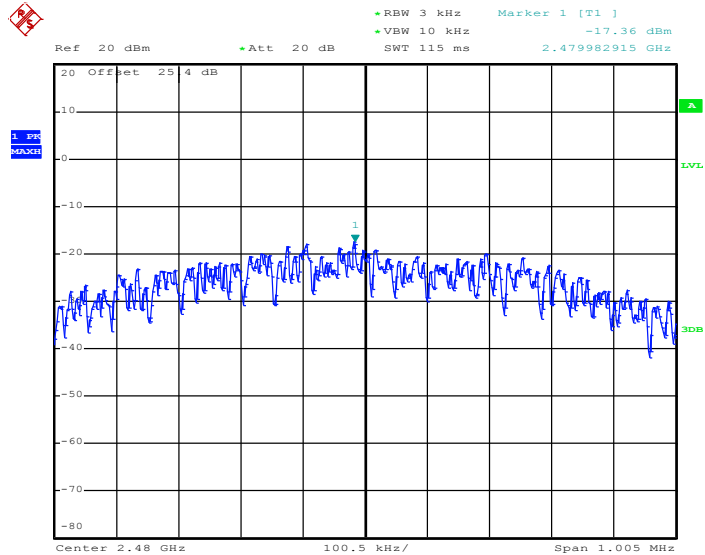

Date: 1.AUG.2014 05:13:06



## 3.4 Conducted Band Edges and Spurious Emission Measurement

### 3.4.1 Limit of Conducted Band Edges and Spurious Emission

All harmonics/spurious must be at least 20 dB down from the highest emission level within the authorized band.

### 3.4.2 Measuring Instruments

The section 4.0 of List of Measuring Equipment of this test report is used for test.

### 3.4.3 Test Procedure

1. The testing follows FCC KDB Publication No. 558074 D01 DTS Meas. Guidance v03r02.
2. The RF output of EUT was connected to the spectrum analyzer by RF cable and attenuator. The path loss was compensated to the results for each measurement.
3. Set to the maximum power setting and enable the EUT transmit continuously.
4. Set RBW = 100 kHz, VBW=300 kHz, Peak Detector. Unwanted Emissions measured in any 100 kHz bandwidth outside of the authorized frequency band shall be attenuated by at least 20 dB relative to the maximum in-band peak PSD level in 100 kHz when maximum peak conducted output power procedure is used. If the transmitter complies with the conducted power limits based on the use of RMS averaging over a time interval, the attenuation required under this paragraph shall be 30 dB instead of 20 dB per 15.247(d).
5. Measure and record the results in the test report.
6. The RF fundamental frequency should be excluded against the limit line in the operating frequency band.

### 3.4.4 Test Setup





### 3.4.5 Test Result of Conducted Band Edges

Test Mode :	Bluetooth 4.0 - LE	Temperature :	22~25°C
Test Channel :	00 and 39	Relative Humidity :	51~55%
		Test Engineer :	Osolemio Chang

Low Band Edge Plot on Channel 00

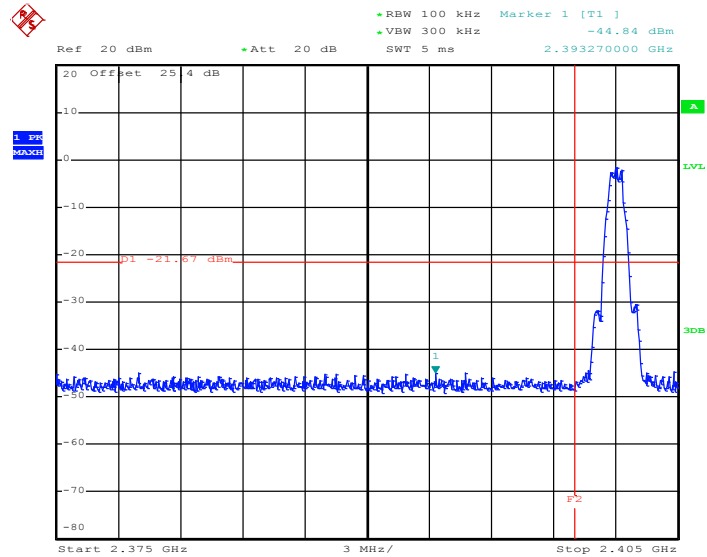

Date: 1.AUG.2014 05:05:16



High Band Edge Plot on Channel 39

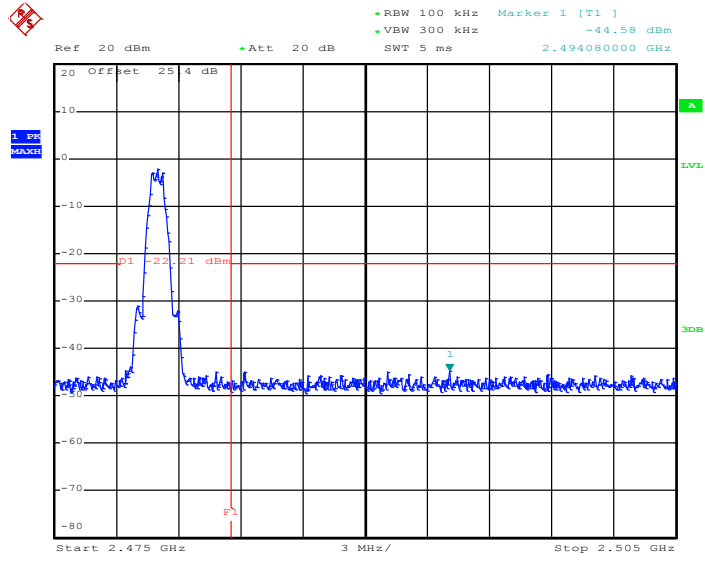

Date: 1.AUG.2014 05:13:48



3.4.6 Test Result of Conducted Spurious Emission

Test Mode :	Bluetooth 4.0 - LE	Temperature :	22~25°C
Test Channel :	00	Relative Humidity :	51~55%
		Test Engineer :	Osolemio Chang

Conducted Spurious Emission Plot on Bluetooth LE 1Mbps GFSK Channel 00

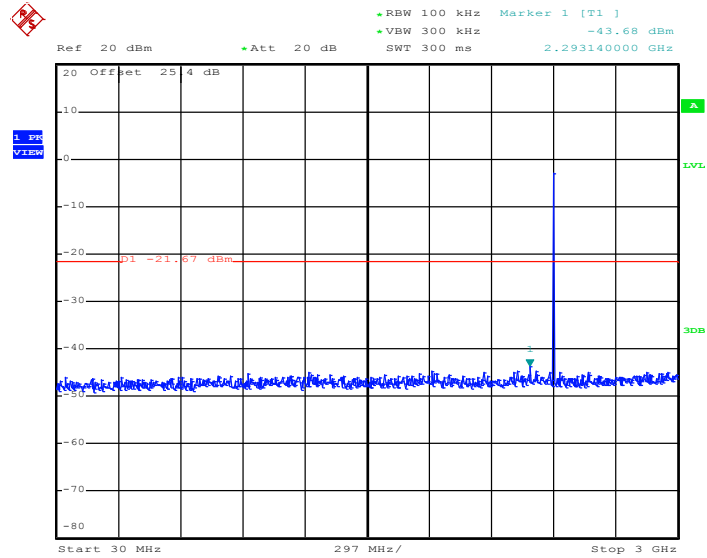

Date: 1.AUG.2014 05:05:43



Conducted Spurious Emission Plot on Bluetooth LE 1Mbps  
GFSK Channel 00

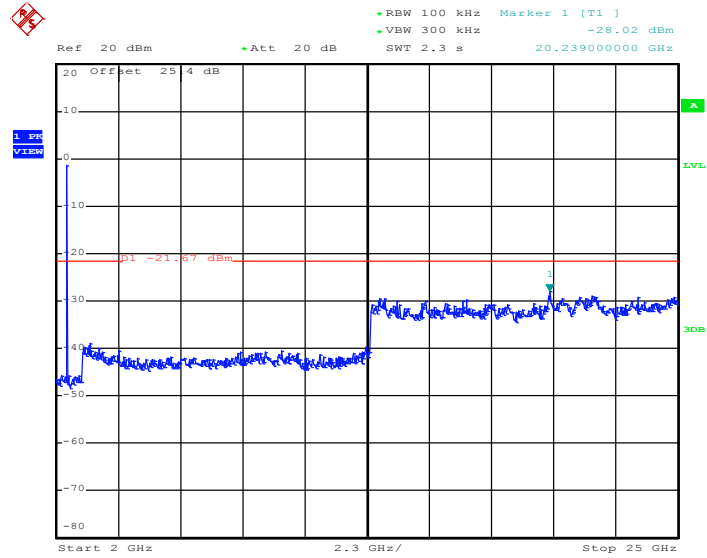

Date: 1.AUG.2014 05:06:01



Test Mode :	Bluetooth 4.0 - LE	Temperature :	22~25°C
Test Channel :	19	Relative Humidity :	51~55%
		Test Engineer :	Osolemio Chang

Conducted Spurious Emission Plot on Bluetooth LE 1Mbps  
GFSK Channel 19

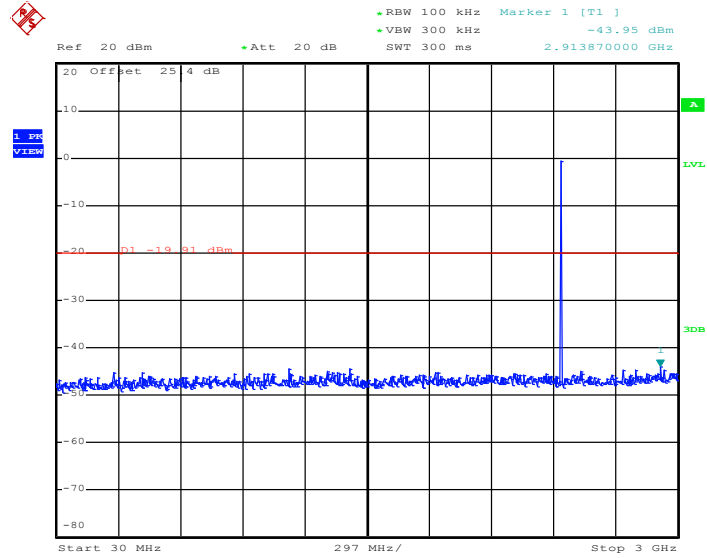

Date: 1.AUG.2014 05:10:32



### Conducted Spurious Emission Plot on Bluetooth LE 1Mbps GFSK Channel 19

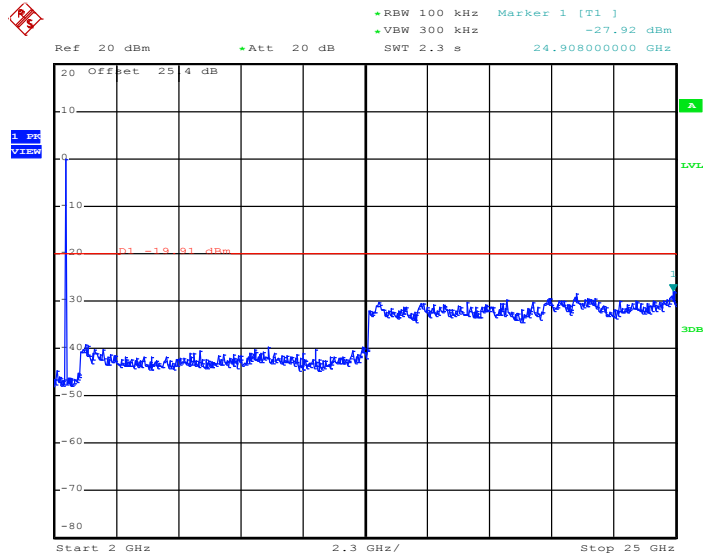

Date: 1.AUG.2014 05:10:50



Test Mode :	Bluetooth 4.0 - LE	Temperature :	22~25°C
Test Channel :	39	Relative Humidity :	51~55%
		Test Engineer :	Osolemio Chang

**Conducted Spurious Emission Plot on Bluetooth LE 1Mbps  
GFSK Channel 39**

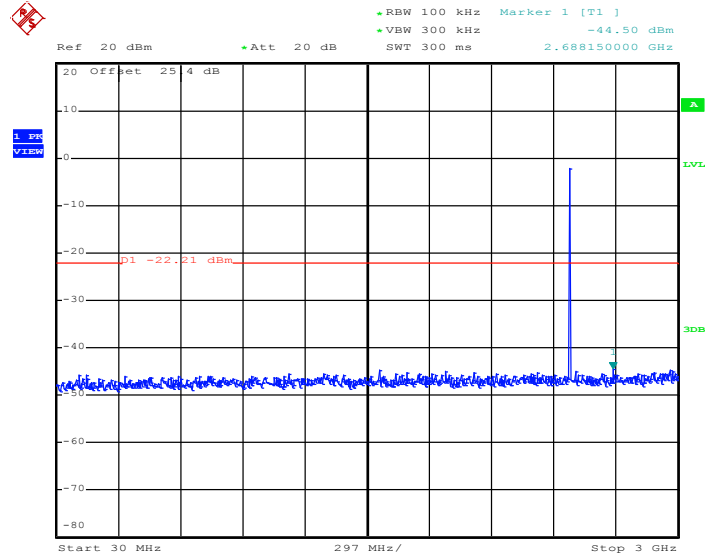

Date: 1.AUG.2014 05:14:13





Conducted Spurious Emission Plot on Bluetooth LE 1Mbps GFSK Channel 39

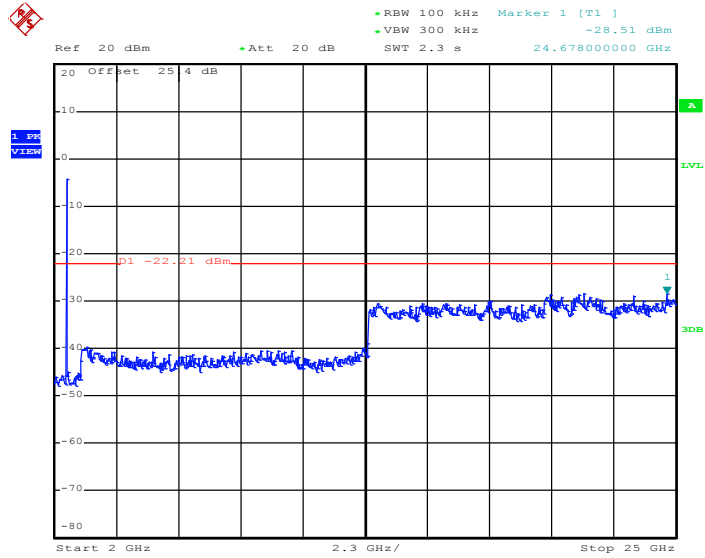

Date: 1.AUG.2014 05:14:31



### 3.5 Radiated Band Edges and Spurious Emission Measurement

#### 3.5.1 Limit of Radiated Band Edges and Spurious Emission

In any 100 kHz bandwidth outside the intentional radiator frequency band, all harmonics/spurious must be at least 20 dB below the highest emission level within the authorized band. If the output power of this device was measured by spectrum analyzer, the attenuation under this paragraph shall be 30 dB instead of 20 dB. In addition, radiated emissions which fall in the restricted bands must also comply with the FCC section 15.209 limits as below.

Frequency (MHz)	Field Strength (microvolts/meter)	Measurement Distance (meters)
0.009 – 0.490	2400/F(kHz)	300
0.490 – 1.705	24000/F(kHz)	30
1.705 – 30.0	30	30
30 – 88	100	3
88 – 216	150	3
216 - 960	200	3
Above 960	500	3

#### 3.5.2 Measuring Instruments

The section 4.0 of List of Measuring Equipment of this test report is used for test.



3.5.3 Test Procedures

1. The testing follows FCC KDB Publication No. 558074 D01 DTS Meas. Guidance v03r02.
2. The EUT was arranged to its worst case and then tune the antenna tower (from 1 m to 4 m) and turntable (from 0 degree to 360 degrees) to find the maximum reading. A pre-amp and a high pass filter are used for the test in order to get better signal level.
3. The EUT was placed on a turntable with 0.8 meter above ground.
4. The EUT was set 3 meters from the interference receiving antenna, which was mounted on the top of a variable height antenna tower.
5. Corrected Reading: Antenna Factor + Cable Loss + Read Level - Preamp Factor = Level
6. For measurement below 1GHz, If the emission level of the EUT measured by the peak detector is 3 dB lower than the applicable limit, the peak emission level will be reported. Otherwise, the emission measurement will be repeated using the quasi-peak detector and reported.
7. Use the following spectrum analyzer settings:
  - (1) Span shall wide enough to fully capture the emission being measured;
  - (2) Set RBW=100 kHz for  $f < 1$  GHz;  $VBW \geq RBW$ ; Sweep = auto; Detector function = peak; Trace = max hold;
  - (3) Set RBW = 1 MHz, VBW= 3MHz for  $f \geq 1$  GHz for peak measurement.
 

For average measurement:

    - $VBW = 10$  Hz, when duty cycle is no less than 98 percent.
    - $VBW \geq 1/T$ , when duty cycle is less than 98 percent where T is the minimum transmission duration over which the transmitter is on and is transmitting at its maximum power control level for the tested mode of operation.

Band	Duty Cycle(%)	T(μs)	1/T(kHz)	VBW Setting
Bluetooth 4.0 - LE	62.66	396	2.53	3kHz

### 3.5.4 Test Setup

For radiated emissions below 30MHz



For radiated emissions from 30MHz to 1GHz

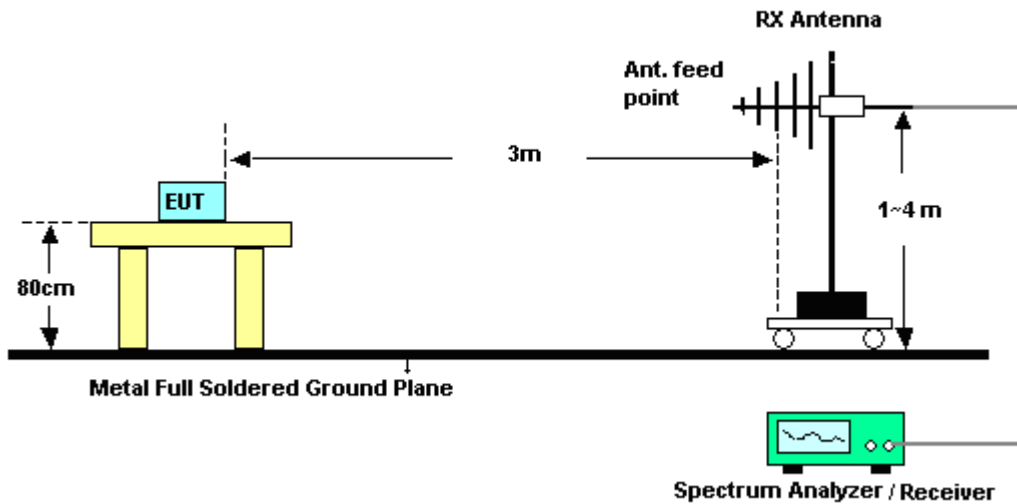

For radiated emissions above 1GHz

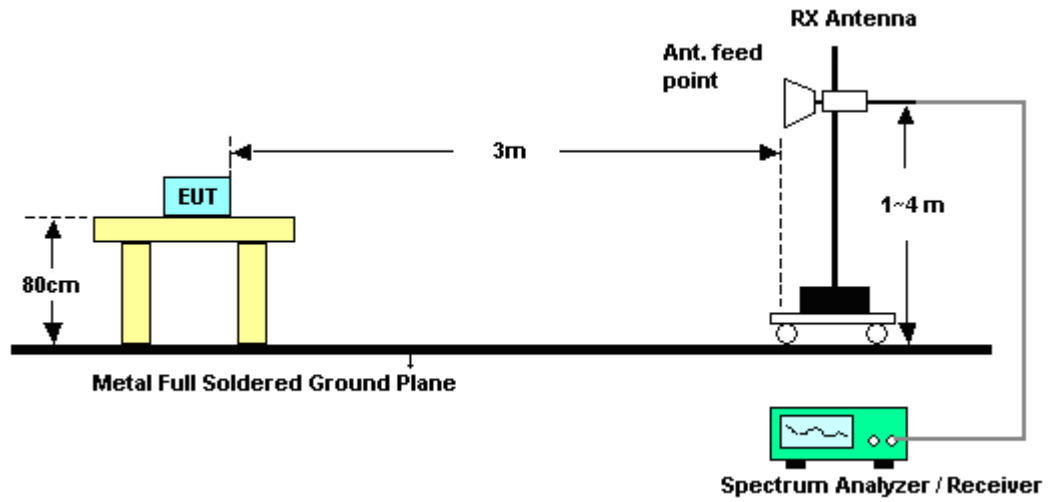



3.5.5 Test Results of Radiated Spurious Emissions (9 kHz ~ 30 MHz)

Test Mode :	Mode 4	Temperature :	22~24°C
Test Channel :	Bluetooth Tx CH39 with WPC Charging Mode	Relative Humidity :	46~48%
Test Engineer :	Kyle Jhuang, Abi Lin and Derreck Chen	Polarization :	Horizontal

Frequency ( MHz )	Level ( dBμV/m )	Over Limit ( dB )	Limit Line ( dBμV/m )	Read Level ( dBμV )	Antenna Factor ( dB )	Cable Loss ( dB )	Ant Pos ( cm )	Table Pos ( deg )	Remark
0.04837	29.76	-84.15	113.91	9.3	20.17	0.29	-	-	Average
0.06054	33.82	-78.14	111.96	13.46	20.07	0.29	-	-	Average
0.0967	23.67	-84.23	107.9	3.33	20.05	0.29	-	-	QP
0.1324	57.47	-47.7	105.17	37.16	20.02	0.29	-	-	Average
0.14176	22.92	-81.65	104.57	2.61	20.02	0.29	-	-	Average
0.19658	52.53	-49.2	101.73	32.27	19.97	0.29	-	-	Average
1.692	42.11	-20.93	63.04	21.84	19.94	0.33	100	185	QP
14	36.21	-33.79	70	16.21	19.6	0.4	-	-	QP
21.004	37.1	-32.9	70	16.57	20.1	0.43	-	-	QP
25.155	36.86	-33.14	70	16.09	20.32	0.45	-	-	QP



<b>Test Mode :</b>	Mode 4	<b>Temperature :</b>	22~24°C
<b>Test Channel :</b>	Bluetooth Tx CH39 with WPC Charging Mode	<b>Relative Humidity :</b>	46~48%
<b>Test Engineer :</b>	Kyle Jhuang, Abi Lin and Derreck Chen	<b>Polarization :</b>	Vertical

Frequency ( MHz )	Level ( dBμV/m )	Over Limit ( dB )	Limit Line ( dBμV/m )	Read Level ( dBμV )	Antenna Factor ( dB )	Cable Loss ( dB )	Ant Pos ( cm )	Table Pos ( deg )	Remark
0.06	28.33	-83.71	112.04	7.97	20.07	0.29	-	-	Average
0.07878	24.01	-85.67	109.68	3.65	20.07	0.29	-	-	Average
0.10292	23.87	-83.48	107.35	3.53	20.05	0.29	-	-	QP
0.12072	26.23	-79.74	105.97	5.92	20.02	0.29	-	-	Average
0.13312	49.62	-55.5	105.12	29.31	20.02	0.29	-	-	Average
0.39718	40.51	-55.11	95.62	20.31	19.91	0.29	-	-	Average
1.346	42.94	-22.08	65.02	22.7	19.93	0.31	100	142	QP
14.544	36.82	-33.18	70	16.79	19.62	0.41	-	-	QP
23.29	39.35	-30.65	70	18.65	20.26	0.44	-	-	QP
25.98	43.37	-26.63	70	22.55	20.35	0.47	-	-	QP



3.5.6 Test Result of Radiated Spurious at Band Edges

Test Mode :	Mode 1	Temperature :	22~24°C
Test Channel :	00	Relative Humidity :	46~48%
		Test Engineer :	Kyle Jhuang, Abi Lin and Derreck Chen

ANTENNA POLARITY : HORIZONTAL										
Frequency ( MHz )	Level (dBμV /m)	Over Limit ( dB )	Limit Line (dBμV /m)	Read Level (dBμV)	Antenna Factor ( dB )	Cable Loss ( dB )	Preamp Factor ( dB )	Ant Pos ( cm )	Table Pos ( deg )	Remark
2313.87	41.23	-32.77	74	43.29	26.98	4.16	33.2	100	63	Peak
2382.18	31.82	-22.18	54	33.6	27.17	4.23	33.18	100	63	Average

ANTENNA POLARITY : VERTICAL										
Frequency ( MHz )	Level (dBμV /m)	Over Limit ( dB )	Limit Line (dBμV /m)	Read Level (dBμV)	Antenna Factor ( dB )	Cable Loss ( dB )	Preamp Factor ( dB )	Ant Pos ( cm )	Table Pos ( deg )	Remark
2346.27	42.05	-31.95	74	43.97	27.07	4.2	33.19	100	158	Peak
2343.48	31.61	-22.39	54	33.55	27.06	4.19	33.19	100	158	Average

Test Mode :	Mode 3	Temperature :	22~24°C
Test Channel :	39	Relative Humidity :	46~48%
		Test Engineer :	Kyle Jhuang, Abi Lin and Derreck Chen

ANTENNA POLARITY : HORIZONTAL										
Frequency ( MHz )	Level (dBμV /m)	Over Limit ( dB )	Limit Line (dBμV /m)	Read Level (dBμV)	Antenna Factor ( dB )	Cable Loss ( dB )	Preamp Factor ( dB )	Ant Pos ( cm )	Table Pos ( deg )	Remark
2483.65	45.16	-28.84	74	46.56	27.45	4.29	33.14	100	60	Peak
2483.5	37.83	-16.17	54	39.23	27.45	4.29	33.14	100	60	Average

ANTENNA POLARITY : VERTICAL										
Frequency ( MHz )	Level (dBμV /m)	Over Limit ( dB )	Limit Line (dBμV /m)	Read Level (dBμV)	Antenna Factor ( dB )	Cable Loss ( dB )	Preamp Factor ( dB )	Ant Pos ( cm )	Table Pos ( deg )	Remark
2497.21	41.56	-32.44	74	42.91	27.49	4.29	33.13	135	153	Peak
2483.5	33.97	-20.03	54	35.37	27.45	4.29	33.14	135	153	Average





<Bluetooth Tx Mode with WPC Charging Mode>

Test Mode :	Mode 4	Temperature :	22~24°C
Test Channel :	39	Relative Humidity :	46~48%
		Test Engineer :	Kyle Jhuang, Abi Lin and Derreck Chen

ANTENNA POLARITY : HORIZONTAL										
Frequency ( MHz )	Level (dBµV /m)	Over Limit ( dB )	Limit Line (dBµV /m)	Read Level (dBµV)	Antenna Factor ( dB )	Cable Loss ( dB )	Preamp Factor ( dB )	Ant Pos ( cm )	Table Pos ( deg )	Remark
2483.5	44.1	-29.9	74	45.5	27.45	4.29	33.14	106	90	Peak
2483.5	36.68	-17.32	54	38.08	27.45	4.29	33.14	106	90	Average

ANTENNA POLARITY : VERTICAL										
Frequency ( MHz )	Level (dBµV /m)	Over Limit ( dB )	Limit Line (dBµV /m)	Read Level (dBµV)	Antenna Factor ( dB )	Cable Loss ( dB )	Preamp Factor ( dB )	Ant Pos ( cm )	Table Pos ( deg )	Remark
2487.25	41.77	-32.23	74	43.16	27.46	4.29	33.14	123	207	Peak
2484.34	32.46	-21.54	54	33.85	27.46	4.29	33.14	123	207	Average



3.5.7 Test Result of Radiated Spurious Emission (30MHz ~ 10<sup>th</sup> Harmonic)

Note: Pre-scanned all test modes and only choose the worst case mode recorded in the test report for radiated spurious emission below 1GHz.

<b>Test Mode :</b>	Mode 1	<b>Temperature :</b>	22~24°C
<b>Test Channel :</b>	00	<b>Relative Humidity :</b>	46~48%
<b>Test Engineer :</b>	Kyle Jhuang, Abi Lin and Derreck Chen	<b>Polarization :</b>	Horizontal
<b>Remark :</b>	1. 2403 MHz is fundamental signal which can be ignored. 2. Average measurement was not performed if peak level went lower than the average limit.		

Frequency ( MHz )	Level ( dBμV/m )	Over Limit ( dB )	Limit Line ( dBμV/m )	Read Level ( dBμV )	Antenna Factor ( dB )	Cable Loss ( dB )	Preamp Factor ( dB )	Ant Pos ( cm )	Table Pos ( deg )	Remark
2403	93.64	-	-	95.33	27.23	4.25	33.17	100	63	Average
2403	93.75	-	-	95.44	27.23	4.25	33.17	100	63	Peak
4803	42.9	-31.1	74	37.57	31.56	6.2	32.43	100	0	Peak

Note: Other harmonics are lower than background noise.

<b>Test Mode :</b>	Mode 1	<b>Temperature :</b>	22~24°C
<b>Test Channel :</b>	00	<b>Relative Humidity :</b>	46~48%
<b>Test Engineer :</b>	Kyle Jhuang, Abi Lin and Derreck Chen	<b>Polarization :</b>	Vertical
<b>Remark :</b>	1. 2403 MHz is fundamental signal which can be ignored. 2. Average measurement was not performed if peak level went lower than the average limit.		

Frequency ( MHz )	Level ( dBμV/m )	Over Limit ( dB )	Limit Line ( dBμV/m )	Read Level ( dBμV )	Antenna Factor ( dB )	Cable Loss ( dB )	Preamp Factor ( dB )	Ant Pos ( cm )	Table Pos ( deg )	Remark
2403	88.62	-	-	90.31	27.23	4.25	33.17	100	158	Average
2403	89	-	-	90.69	27.23	4.25	33.17	100	158	Peak
4803	42.44	-31.56	74	37.11	31.56	6.2	32.43	100	0	Peak

Note: Other harmonics are lower than background noise.



<b>Test Mode :</b>	Mode 2	<b>Temperature :</b>	22~24°C
<b>Test Channel :</b>	19	<b>Relative Humidity :</b>	46~48%
<b>Test Engineer :</b>	Kyle Jhuang, Abi Lin and Derreck Chen	<b>Polarization :</b>	Horizontal
<b>Remark :</b>	1. 2441 MHz is fundamental signal which can be ignored. 2. Average measurement was not performed if peak level went lower than the average limit.		

Frequency ( MHz )	Level ( dBμV/m )	Over Limit ( dB )	Limit Line ( dBμV/m )	Read Level ( dBμV )	Antenna Factor ( dB )	Cable Loss ( dB )	Preamp Factor ( dB )	Ant Pos ( cm )	Table Pos ( deg )	Remark
2441	94.66	-	-	96.21	27.33	4.27	33.15	100	62	Average
2441	95	-	-	96.55	27.33	4.27	33.15	100	62	Peak
4881	42.64	-31.36	74	37.1	31.66	6.29	32.41	100	0	Peak
7320	50.23	-23.77	74	38.91	36.63	8.41	33.72	100	0	Peak

**Note:** Other harmonics are lower than background noise.

<b>Test Mode :</b>	Mode 2	<b>Temperature :</b>	22~24°C
<b>Test Channel :</b>	19	<b>Relative Humidity :</b>	46~48%
<b>Test Engineer :</b>	Kyle Jhuang, Abi Lin and Derreck Chen	<b>Polarization :</b>	Vertical
<b>Remark :</b>	1. 2441 MHz is fundamental signal which can be ignored. 2. Average measurement was not performed if peak level went lower than the average limit.		

Frequency ( MHz )	Level ( dBμV/m )	Over Limit ( dB )	Limit Line ( dBμV/m )	Read Level ( dBμV )	Antenna Factor ( dB )	Cable Loss ( dB )	Preamp Factor ( dB )	Ant Pos ( cm )	Table Pos ( deg )	Remark
2441	90.96	-	-	92.51	27.33	4.27	33.15	116	172	Average
2441	91.6	-	-	93.15	27.33	4.27	33.15	116	172	Peak
4881	43.22	-30.78	74	37.68	31.66	6.29	32.41	100	0	Peak
7320	49.65	-24.35	74	38.33	36.63	8.41	33.72	100	0	Peak

**Note:** Other harmonics are lower than background noise.



<b>Test Mode :</b>	Mode 3	<b>Temperature :</b>	22~24°C
<b>Test Channel :</b>	39	<b>Relative Humidity :</b>	46~48%
<b>Test Engineer :</b>	Kyle Jhuang, Abi Lin and Derreck Chen	<b>Polarization :</b>	Horizontal
<b>Remark :</b>	1. 2481 MHz is fundamental signal which can be ignored. 2. Average measurement was not performed if peak level went lower than the average limit.		

Frequency ( MHz )	Level ( dBμV/m )	Over Limit ( dB )	Limit Line (dBμV/m )	Read Level (dBμV)	Antenna Factor ( dB )	Cable Loss ( dB )	Preamp Factor ( dB )	Ant Pos ( cm )	Table Pos ( deg )	Remark
70.23	27.01	-12.99	40	42.51	11.85	0.71	28.06	100	54	Peak
236.01	21.94	-24.06	46	36.92	11.96	1.23	28.17	-	-	Peak
267.87	25.91	-20.09	46	39.66	13.11	1.31	28.17	-	-	Peak
505.8	22.81	-23.19	46	30.77	18.18	1.82	27.96	-	-	Peak
713.7	28.48	-17.52	46	32.4	21.52	2.23	27.67	-	-	Peak
911.1	29.85	-16.15	46	30.41	23.96	2.57	27.09	-	-	Peak
2481	93.87	-	-	95.27	27.45	4.29	33.14	100	60	Average
2481	94.44	-	-	95.84	27.45	4.29	33.14	100	60	Peak
4959	42.58	-31.42	74	36.85	31.75	6.38	32.4	100	0	Peak
7440	49.38	-24.62	74	38.09	36.94	8.17	33.82	100	0	Peak

**Note:** Other harmonics are lower than background noise.



<b>Test Mode :</b>	Mode 3	<b>Temperature :</b>	22~24°C
<b>Test Channel :</b>	39	<b>Relative Humidity :</b>	46~48%
<b>Test Engineer :</b>	Kyle Jhuang, Abi Lin and Derreck Chen	<b>Polarization :</b>	Vertical
<b>Remark :</b>	1. 2481 MHz is fundamental signal which can be ignored. 2. Average measurement was not performed if peak level went lower than the average limit.		

Frequency ( MHz )	Level ( dBμV/m )	Over Limit ( dB )	Limit Line (dBμV/m )	Read Level (dBμV)	Antenna Factor ( dB )	Cable Loss ( dB )	Preamp Factor ( dB )	Ant Pos ( cm )	Table Pos ( deg )	Remark
49.71	25.11	-14.89	40	38.12	14.39	0.6	28	-	-	Peak
163.38	18.11	-25.39	43.5	31.73	13.53	1	28.15	-	-	Peak
243.84	18.2	-27.8	46	32.84	12.28	1.25	28.17	-	-	Peak
550.6	26.03	-19.97	46	33.23	18.82	1.89	27.91	-	-	Peak
673.1	26.95	-19.05	46	31.58	20.87	2.24	27.74	-	-	Peak
957.3	32.45	-13.55	46	32.21	24.53	2.62	26.91	100	114	Peak
2481	88.07	-	-	89.47	27.45	4.29	33.14	135	153	Average
2481	88.61	-	-	90.01	27.45	4.29	33.14	135	153	Peak
4959	42.49	-31.51	74	36.76	31.75	6.38	32.4	100	0	Peak
7440	49.39	-24.61	74	38.1	36.94	8.17	33.82	100	0	Peak

**Note:** Other harmonics are lower than background noise.



### 3.6 AC Conducted Emission Measurement

#### 3.6.1 Limit of AC Conducted Emission

For equipment that is designed to be connected to the public utility (AC) power line, the radio frequency voltage that is conducted back onto the AC power line on any frequency or frequencies within the band 150 kHz to 30 MHz shall not exceed the limits in the following table.

Frequency of emission (MHz)	Conducted limit (dB $\mu$ V)	
	Quasi-peak	Average
0.15-0.5	66 to 56*	56 to 46*
0.5-5	56	46
5-30	60	50

\*Decreases with the logarithm of the frequency.

#### 3.6.2 Measuring Instruments

The section 4.0 of List of Measuring Equipment of this test report is used for test.

#### 3.6.3 Test Procedures

1. The EUT was placed 0.4 meter from the conducting wall of the shielding room was kept at least 80 centimeters from any other grounded conducting surface.
2. Connect EUT to the power mains through a line impedance stabilization network (LISN).
3. All the support units are connecting to the other LISN.
4. The LISN provides 50 ohm coupling impedance for the measuring instrument.
5. The FCC states that a 50 ohm, 50 microhenry LISN should be used.
6. Both sides of AC line were checked for maximum conducted interference.
7. The frequency range from 150 kHz to 30 MHz was searched.
8. Set the test-receiver system to Peak Detect Function and specified bandwidth (IF bandwidth = 9kHz) with Maximum Hold Mode.

### 3.6.4 Test Setup





3.6.5 Test Result of AC Conducted Emission

Test Mode :	Mode 1	Temperature :	20~22°C
Test Engineer :	Cosmo Xu	Relative Humidity :	45~47%
Test Voltage :	120Vac / 60Hz	Phase :	Line
Function Type :	GSM1900 Idle + WLAN Link + Bluetooth Link + Earphone + USB Cable (Data Link with Notebook) + GPS Rx + Battery		

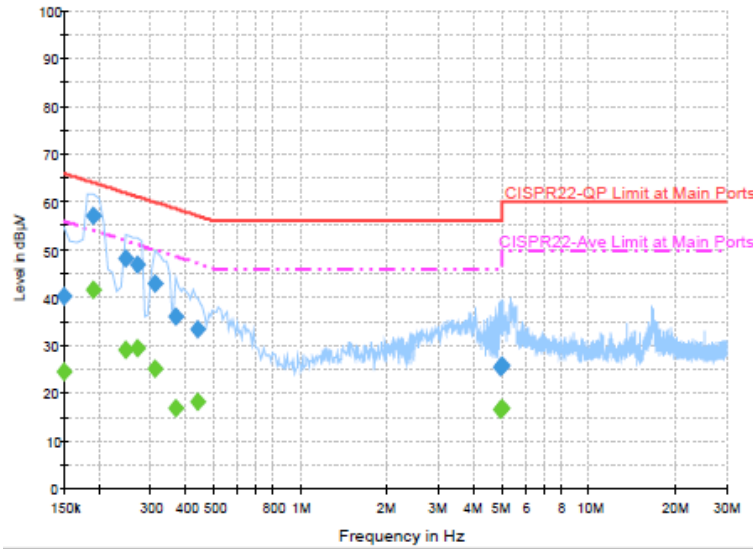

Final Result : Quasi-Peak

Frequency (MHz)	Quasi-Peak (dBµV)	Filter	Line	Corr. (dB)	Margin (dB)	Limit (dBµV)
0.150000	40.2	Off	L1	19.3	25.8	66.0
0.190000	57.2	Off	L1	19.3	6.8	64.0
0.246000	48.1	Off	L1	19.4	13.8	61.9
0.270000	46.9	Off	L1	19.4	14.2	61.1
0.310000	42.9	Off	L1	19.4	17.1	60.0
0.366000	36.1	Off	L1	19.4	22.5	58.6
0.438000	33.4	Off	L1	19.4	23.7	57.1
4.886000	25.4	Off	L1	19.6	30.6	56.0
4.950000	25.9	Off	L1	19.6	30.1	56.0

Final Result : Average

Frequency (MHz)	Average (dBµV)	Filter	Line	Corr. (dB)	Margin (dB)	Limit (dBµV)
0.150000	24.3	Off	L1	19.3	31.7	56.0
0.190000	41.6	Off	L1	19.3	12.4	54.0
0.246000	29.0	Off	L1	19.4	22.9	51.9
0.270000	29.4	Off	L1	19.4	21.7	51.1
0.310000	25.2	Off	L1	19.4	24.8	50.0
0.366000	16.7	Off	L1	19.4	31.9	48.6
0.438000	18.3	Off	L1	19.4	28.8	47.1
4.886000	16.7	Off	L1	19.6	29.3	46.0
4.950000	16.7	Off	L1	19.6	29.3	46.0





Test Mode :	Mode 1	Temperature :	20~22°C
Test Engineer :	Cosmo Xu	Relative Humidity :	45~47%
Test Voltage :	120Vac / 60Hz	Phase :	Neutral
Function Type :	GSM1900 Idle + WLAN Link + Bluetooth Link + Earphone + USB Cable (Data Link with Notebook) + GPS Rx + Battery		

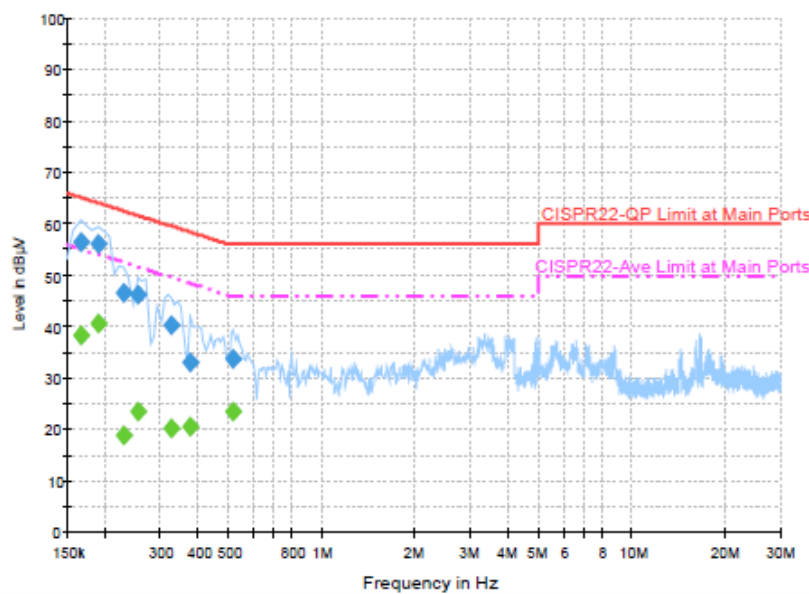

**Final Result : Quasi-Peak**

Frequency (MHz)	Quasi-Peak (dBµV)	Filter	Line	Corr. (dB)	Margin (dB)	Limit (dBµV)
0.166000	56.5	Off	N	19.3	8.7	65.2
0.190000	56.2	Off	N	19.3	7.8	64.0
0.230000	46.6	Off	N	19.4	15.8	62.4
0.254000	46.1	Off	N	19.4	15.5	61.6
0.326000	40.2	Off	N	19.4	19.4	59.6
0.374000	33.0	Off	N	19.4	25.4	58.4
0.518000	33.6	Off	N	19.4	22.4	56.0

**Final Result : Average**

Frequency (MHz)	Average (dBµV)	Filter	Line	Corr. (dB)	Margin (dB)	Limit (dBµV)
0.166000	38.4	Off	N	19.3	16.8	55.2
0.190000	40.6	Off	N	19.3	13.4	54.0
0.230000	18.9	Off	N	19.4	33.5	52.4
0.254000	23.4	Off	N	19.4	28.2	51.6
0.326000	20.2	Off	N	19.4	29.4	49.6
0.374000	20.5	Off	N	19.4	27.9	48.4
0.518000	23.4	Off	N	19.4	22.6	46.0



## **3.7 Antenna Requirements**

### **3.7.1 Standard Applicable**

If directional gain of transmitting antennas is greater than 6dBi, the power shall be reduced by the same level in dB comparing to gain minus 6dBi. The use of a permanently attached antenna or of an antenna that uses a unique coupling to the intentional radiator shall be considered sufficient to comply with the FCC rule.

### **3.7.2 Antenna Anti-Replacement Construction**

An embedded-in antenna design is used.

### **3.7.3 Antenna Gain**

The antenna peak gain of EUT is less than 6 dBi. Therefore, it is not necessary to reduce maximum peak output power limit.



## 4 List of Measuring Equipment

Instrument	Manufacturer	Model No.	Serial No.	Characteristics	Calibration Date	Test Date	Due Date	Remark
Spectrum Analyzer	Rohde & Schwarz	FSP40	100055	9kHz~40GHz	Jun. 09, 2014	Jul. 18, 2014~ Aug. 01, 2014	Jun. 08, 2015	Conducted (TH02-HY)
Power Meter	Agilent	E4416A	GB41292344	300MHz~40GHz	Jan. 28, 2014	Jul. 18, 2014~ Aug. 01, 2014	Jan. 27, 2015	Conducted (TH02-HY)
Power Sensor	Agilent	E9327A	US40441548	300MHz~40GHz	Jan. 28, 2014	Jul. 18, 2014~ Aug. 01, 2014	Jan. 27, 2015	Conducted (TH02-HY)
EMI Test Receiver	Rohde & Schwarz	ESCI 7	100724	9 kHz~7 GHz	Sep. 06, 2013	Jul. 20, 2014~ Jul. 26, 2014	Sep. 05, 2014	Radiation (03CH07-HY)
Spectrum Analyzer	Rohde & Schwarz	FSV30	101749	10Hz ~ 30GHz	Feb. 10, 2014	Jul. 20, 2014~ Jul. 26, 2014	Feb. 09, 2015	Radiation (03CH07-HY)
Loop Antenna	TESEQ	HLA 6120	31244	9 kHz~30 MhZ	Dec. 02, 2012	Jul. 20, 2014~ Jul. 26, 2014	Dec. 03, 2014	Radiation (03CH07-HY)
Bilog Antenna	Schaffner	CBL6111C	2726	30 MHz ~ 1 GHz	Oct. 10, 2013	Jul. 20, 2014~ Jul. 26, 2014	Oct. 09, 2014	Radiation (03CH07-HY)
Double Ridge Horn Antenna	ESCO	3117	75962	1 GHz~18 GHz	Aug. 22, 2013	Jul. 20, 2014~ Jul. 26, 2014	Aug. 21, 2014	Radiation (03CH07-HY)
SHF-EHF Horn Antenna	SCHWARZBECK	BBHA 9170	BBHA91702 51	15 GHz- 40 GHz	Oct. 03, 2013	Jul. 20, 2014~ Jul. 26, 2014	Oct. 02, 2014	Radiation (03CH07-HY)
Preamplifier	COM-POWER	PA-103A	161241	10 MHz ~ 1 GHz	Mar. 17, 2014	Jul. 20, 2014~ Jul. 26, 2014	Mar. 16, 2015	Radiation (03CH07-HY)
Preamplifier	Agilent	8449B	3008A02362	1 GHz~26.5 GHz	Nov. 29, 2013	Jul. 20, 2014~ Jul. 26, 2014	Nov. 28, 2014	Radiation (03CH07-HY)
Preamplifier	MITEQ	AMF-7D-0010 1800-30-10P	159075	1 GHz ~18 GHz	Apr. 21, 2014	Jul. 20, 2014~ Jul. 26, 2014	Apr. 20, 2015	Radiation (03CH07-HY)
Turn Table	ChainTek	ChainTek 3000	N/A	0 ~ 360 degree	N/A	Jul. 20, 2014~ Jul. 26, 2014	N/A	Radiation (03CH07-HY)
Antenna Mast	ChainTek	ChainTek 3000	N/A	N/A	N/A	Jul. 20, 2014~ Jul. 26, 2014	N/A	Radiation (03CH07-HY)
EMI Test Receiver	Rohde & Schwarz	ESCS 30	100356	9kHz ~ 2.75GHz	Nov. 15, 2013	Jul. 31, 2014	Nov. 14, 2014	Conduction (CO05-HY)
LISN (for auxiliary equipment)	Rohde & Schwarz	ENV216	100081	9kHz ~ 30MHz	Dec. 12, 2013	Jul. 31, 2014	Dec. 11, 2014	Conduction (CO05-HY)
LISN	Rohde & Schwarz	ENV216	100080	9kHz ~ 30MHz	Dec. 04, 2013	Jul. 31, 2014	Dec. 03, 2014	Conduction (CO05-HY)
AC Power Source	ChainTek	APC-1000W	N/A	N/A	N/A	Jul. 31, 2014	N/A	Conduction (CO05-HY)



## 5 Uncertainty of Evaluation

### Uncertainty of Conducted Emission Measurement (150 kHz ~ 30 MHz)

Measuring Uncertainty for a Level of Confidence of 95% ( $U = 2Uc(y)$ )	2.26
---	------

### Uncertainty of Radiated Emission Measurement (30 MHz ~ 1000 MHz)

Measuring Uncertainty for a Level of Confidence of 95% ( $U = 2Uc(y)$ )	4.50
---	------

