



# FCC RF Test Report

**APPLICANT** : Bullitt Group  
**EQUIPMENT** : Rugged Smart Phone  
**BRAND NAME** : CAT  
**MODEL NAME** : S48c  
**FCC ID** : ZL5S48C  
**STANDARD** : 47 CFR Part 2, 22(H), 24(E), 27(H), 27(L), 27(F),  
27(M)  
**CLASSIFICATION** : PCS Licensed Transmitter Held to Ear (PCE)

The product was received on Aug. 08, 2018 and completely tested on Sep. 11, 2018. We, Sporton International (Shenzhen) Inc., would like to declare that the tested sample has been evaluated in accordance with the procedures given in ANSI C63.26-2015 and shown compliance with the applicable technical standards.

The test results in this report apply exclusively to the tested model / sample. Without written approval of Sporton International (Shenzhen) Inc., the test report shall not be reproduced except in full.



Approved by: Eric Shih / Manager

**Sporton International (Shenzhen) Inc.**

1/F, 2/F, Bldg 5, Shiling Industrial Zone, Xinwei Village, Xili, Nanshan, Shenzhen City,  
Guangdong Province 518055, China



TABLE OF CONTENTS

REVISION HISTORY..... 3
SUMMARY OF TEST RESULT ..... 4
1 GENERAL DESCRIPTION ..... 5
1.1 Applicant ..... 5
1.2 Product Feature of Equipment Under Test..... 5
1.3 Product Specification of Equipment Under Test..... 6
1.4 Modification of EUT ..... 6
1.5 Maximum ERP/EIRP Power, Frequency Tolerance, and Emission Designator ..... 7
1.6 Testing Location ..... 8
1.7 Applicable Standards..... 8
2 TEST CONFIGURATION OF EQUIPMENT UNDER TEST ..... 9
2.1 Test Mode ..... 9
2.2 Connection Diagram of Test System..... 10
2.3 Support Unit used in test configuration and system ..... 10
2.4 Measurement Results Explanation Example..... 10
2.5 Frequency List of Low/Middle/High Channels ..... 11
3 CONDUCTED TEST ITEMS ..... 12
3.1 Measuring Instruments ..... 12
3.2 Test Setup ..... 12
3.3 Test Result of Conducted Test ..... 12
3.4 Conducted Output Power and ERP/EIRP ..... 13
3.5 Peak-to-Average Ratio ..... 14
3.6 Occupied Bandwidth..... 15
3.7 Conducted Band Edge ..... 16
3.8 Conducted Spurious Emission ..... 18
3.9 Frequency Stability ..... 19
4 RADIATED TEST ITEMS ..... 20
4.1 Measuring Instruments ..... 20
4.2 Test Setup ..... 20
4.3 Test Result of Radiated Test ..... 20
4.4 Radiated Spurious Emission ..... 21
5 LIST OF MEASURING EQUIPMENT ..... 22
6 UNCERTAINTY OF EVALUATION ..... 23
APPENDIX A. TEST RESULTS OF CONDUCTED TEST
APPENDIX B. TEST RESULTS OF RADIATED TEST
APPENDIX C. TEST SETUP PHOTOGRAPHS
APPENDIX D. PRODUCT EQUALITY DECLARATION





### SUMMARY OF TEST RESULT

Report Section	FCC Rule	Description	Limit	Result	Remark
3.4	§2.1046	Conducted Output Power	Reporting Only	PASS	-
	§27.50(b)(10)	Effective Radiated Power (Band 13)	ERP < 3 Watt	PASS	-
3.5	§24.232(d)	Peak-to-Average Ratio	<13 dB	PASS	-
3.6	§2.1049	Occupied Bandwidth	Reporting Only	PASS	-
3.7	§2.1051 §27.53(c)(2)(4)	Conducted Band Edge Measurement (Band 13)	< 43+10log <sub>10</sub> (P[Watts])	PASS	-
3.8	§2.1051 §27.53(c)(2)	Conducted Spurious Emission (Band 13)	< 43+10log <sub>10</sub> (P[Watts])	PASS	-
3.9	§2.1055 §22.355	Frequency Stability Temperature & Voltage	< 2.5 ppm	PASS	-
4.4	§2.1053 §27.53(c)(2) §27.53(f)	Radiated Spurious Emission (Band 13)	< 43+10log <sub>10</sub> (P[Watts])	PASS	Under limit 16.11 dB at 5177.180 MHz
	§2.1053 §27.53(m)(4)	Radiated Spurious Emission (Band 41)	< 55+10log <sub>10</sub> (P[Watts])		



# 1 General Description

## 1.1 Applicant

**Bullitt Group**

One Valpy, Valpy Street, Reading, Berkshire, England RG1 1AR

## 1.2 Product Feature of Equipment Under Test

Product Feature	
Equipment	Rugged Smart Phone
Brand Name	CAT
Model Name	S48c
FCC ID	ZL5S48C
EUT supports Radios application	CDMA/EV-DO/GSM/GPRS/EGPRS/WCDMA/HSPA/HSPA+/DC-HSDPA/LTE/NFC WLAN 2.4GHz 802.11b/g/n HT20/HT40 WLAN 5GHz 802.11a/n HT20/HT40 WLAN 5GHz 802.11ac VHT20/VHT40/VHT80 Bluetooth BR/EDR/LE
IMEI Code	Conducted: 35801609001837 Radiation: 358016090018197 for LTE Band 13/41
EUT Stage	Identical Prototype

**Remark:**

1. The above EUT's information was declared by manufacturer. Please refer to the specifications or user's manual for more detailed description.
2. This is a variant report for S48c. The product equality declaration could be referred to Appendix D. Based on the similarity between current and previous project, full test of LTE Band 13 and the worst case of Radiation Spurious Emission of LTE Band 41 from original test report (Sporton Report Number FG850804-03B) were verified for the differences.



### 1.3 Product Specification of Equipment Under Test

Standards-related Product Specification	
<b>Tx Frequency</b>	LTE Band 2 : 1850.7 MHz ~ 1909.3 MHz LTE Band 4 : 1710.7 MHz ~ 1754.3 MHz LTE Band 5 : 824.7 MHz ~ 848.3 MHz LTE Band 7 : 2502.5 MHz ~ 2567.5 MHz LTE Band 12 : 699.7 MHz ~ 715.3 MHz LTE Band 13 : 779.5 MHz ~ 784.5 MHz LTE Band 25 : 1850.7MHz ~ 1914.3 MHz LTE Band 26 : 824.7MHz ~ 848.3 MHz LTE Band 41 : 2498.5 MHz ~ 2687.5 MHz LTE Band 66 : 1710.7 MHz ~ 1779.3 MHz
<b>Rx Frequency</b>	LTE Band 2 : 1930.7 MHz ~ 1989.3 MHz LTE Band 4 : 2110.7 MHz ~ 2154.3 MHz LTE Band 5 : 869.7 MHz ~ 893.3 MHz LTE Band 7 : 2622.5MHz ~ 2687.5 MHz LTE Band 12 : 729.7 MHz ~ 745.3 MHz LTE Band 13 : 748.5 MHz ~ 753.5 MHz LTE Band 25 : 1930.7MHz ~ 1994.3 MHz LTE Band 26 : 869.7MHz ~ 893.3MHz LTE Band 41 : 2498.5 MHz ~ 2687.5 MHz LTE Band 66 : 2110.7 MHz~ 2199.3 MHz
<b>Bandwidth</b>	LTE Band 2 : 1.4MHz / 3MHz / 5MHz / 10MHz / 15MHz / 20MHz LTE Band 4 : 1.4MHz / 3MHz / 5MHz / 10MHz / 15MHz / 20MHz LTE Band 5 : 1.4MHz / 3MHz / 5MHz / 10MHz LTE Band 7 : 5MHz / 10MHz / 15MHz / 20MHz LTE Band 12 : 1.4MHz / 3MHz / 5MHz / 10MHz LTE Band 13 : 5MHz / 10MHz LTE Band 25 : 1.4MHz / 3MHz / 5MHz / 10MHz / 15MHz / 20MHz LTE Band 26 : 1.4MHz / 3MHz / 5MHz / 10MHz / 15MHz LTE Band 41 : 5MHz / 10MHz / 15MHz / 20MHz LTE Band 66 : 1.4MHz / 3MHz / 5MHz / 10MHz / 15MHz / 20MHz
<b>Maximum Output Power to Antenna</b>	LTE Band 13 : 24.41 dBm
<b>Antenna Gain</b>	LTE Band 2 : -0.5 dBi LTE Band 4 : -0.5 dBi LTE Band 5 : -1.2 dBi LTE Band 7 : -0.2 dBi LTE Band 12 : -1.3 dBi LTE Band 13 : -1.3 dBi LTE Band 25 : -0.5 dBi LTE Band 26 : -1.2 dBi LTE Band 41 : -0.2 dBi LTE Band 66 : -0.5 dBi
<b>Type of Modulation</b>	QPSK / 16QAM / 64QAM

### 1.4 Modification of EUT

No modifications are made to the EUT during all test items.



### 1.5 Maximum ERP/EIRP Power, Frequency Tolerance, and Emission Designator

LTE Band 13		QPSK			16QAM		
BW (MHz)	Frequency Range (MHz)	Emission Designator (99%OBW)	Frequency Tolerance (ppm)	Maximum ERP(W)	Emission Designator (99%OBW)	Frequency Tolerance (ppm)	Maximum ERP(W)
5	779.5 ~ 784.5	4M51G7D	-	0.1233	4M51W7D	-	0.1099
10	782.0	9M01G7D	0.0009	0.1247	9M05W7D	-	0.0977
LTE Band 13		64QAM					
BW (MHz)	Frequency Range (MHz)	Emission Designator (99%OBW)		Frequency Tolerance (ppm)	Maximum ERP(W)		
5	779.5 ~ 784.5	4M51W7D		-	0.0764		
10	782.0	8M97W7D		-	0.0764		



### 1.6 Testing Location

Sporton International (Shenzhen) Inc. is accredited to ISO 17025 by National Voluntary Laboratory Accreditation Program (NVLAP code: 600156-0) and the FCC designation No. are CN5018 and CN5019.

<b>Test Site</b>	Sporton International (Shenzhen) Inc.	
<b>Test Site Location</b>	1/F, 2/F, Bldg 5, Shiling Industrial Zone, Xinwei Village, Xili, Nanshan Shenzhen City Guangdong Province 518055 China TEL: +86-755-8637-9589 FAX: +86-755-8637-9595	
<b>Test Site No.</b>	<b>Sporton Site No.</b>	<b>FCC Test Firm Registration No.</b>
	TH01-SZ	337463

<b>Test Site</b>	Sporton International (Shenzhen) Inc.	
<b>Test Site Location</b>	No. 3 Bldg the third floor of south, Shahe River west, Fengzeyuan Warehouse, Nanshan District Shenzhen City Guangdong Province 518055 China TEL: +86-755-3320-2398	
<b>Test Site No.</b>	<b>Sporton Site No.</b>	<b>FCC Test Firm Registration No.</b>
	03CH03-SZ 03CH04-SZ	577730

**Note:** The test site complies with ANSI C63.4 2014 requirement.

### 1.7 Applicable Standards

According to the specifications of the manufacturer, the EUT must comply with the requirements of the following standards:

- 47 CFR Part 2, 22(H), 24(E), 27(H), 27(L), 27(F), 27(M)
- ANSI C63.26-2015
- FCC KDB 971168 D01 Power Meas License Digital Systems v03r01
- FCC KDB 412172 D01 Determining ERP and EIRP v01r01

**Remark:**

1. All test items were verified and recorded according to the standards and without any deviation during the test.
2. This EUT has also been tested and complied with the requirements of FCC Part 15, Subpart B, recorded in a separate test report.





## 2 Test Configuration of Equipment Under Test

### 2.1 Test Mode

Antenna port conducted and radiated test items listed below are performed according to KDB 971168 D01 Power Meas License Digital Systems v03r01 with maximum output power.

Radiated measurements are performed by rotating the EUT in three different orthogonal test planes to find the maximum emission.

Test Items	Band	Bandwidth (MHz)						Modulation			RB #			Test Channel		
		1.4	3	5	10	15	20	QPSK	16QAM	64QAM	1	Half	Full	L	M	H
Max. Output Power	13	-	-	v	v	-	-	v	v	v	v	v	v	v	v	v
Peak-to-Average Ratio	13	-	-		v	-	-	v	v	v	v		v	v	v	v
26dB and 99% Bandwidth	13	-	-	v	v	-	-	v	v	v			v	v	v	v
Conducted Band Edge	13	-	-	v	v	-	-	v	v	v	v		v	v		v
Conducted Spurious Emission	13	-	-	v	v	-	-	v	v	v	v			v	v	v
Frequency Stability	13	-	-		v	-	-	v					v		v	
E.R.P / E.I.R.P	13	-	-	v	v	-	-	v	v	v	v			v	v	v
Radiated Spurious Emission	13	Worst Case												v		
	41	Worst Case												v		
Note	<ol style="list-style-type: none"> <li>The mark "v" means that this configuration is chosen for testing</li> <li>The mark "-" means that this bandwidth is not supported.</li> <li>The device is investigated from 30MHz to 10 times of fundamental signal for radiated spurious emission test under different RB size/offset and modulations in exploratory test. Subsequently, only the worst case emissions are reported.</li> </ol>															

## 2.2 Connection Diagram of Test System

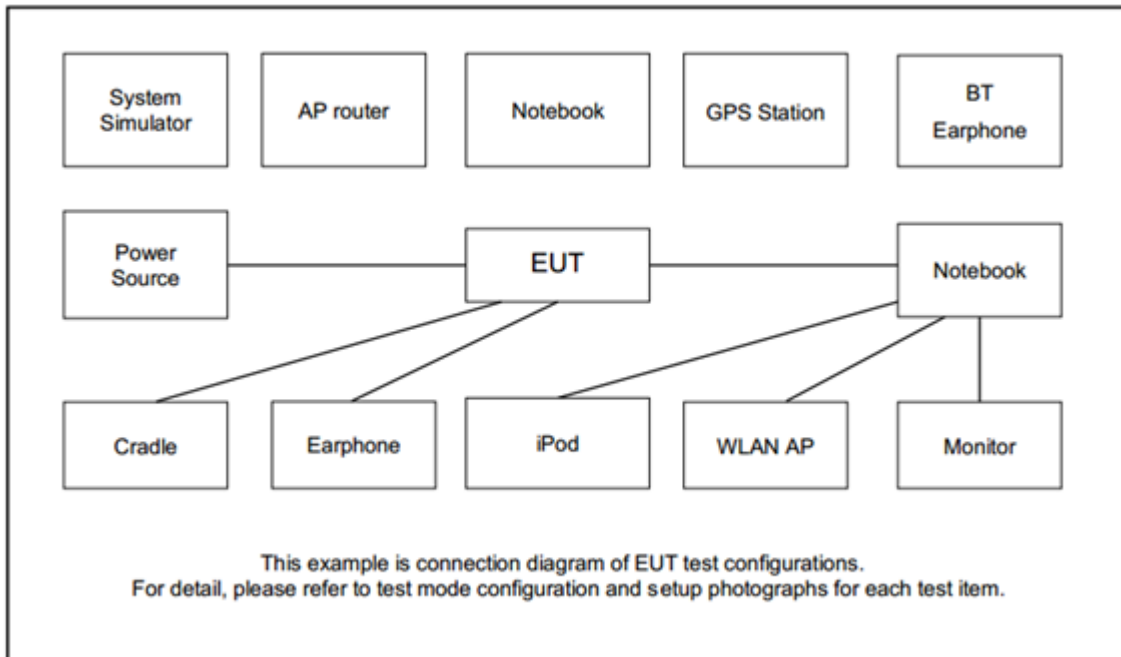

## 2.3 Support Unit used in test configuration and system

Item	Equipment	Trade Name	Model No.	FCC ID	Data Cable	Power Cord
1.	LTE Base Station	Anritsu	MT8820C	N/A	N/A	Unshielded, 1.8m
2.	Earphone	Apple	MC690ZP/A	N/A	Shielded, 1.0m	N/A

## 2.4 Measurement Results Explanation Example

For all conducted test items:

The offset level is set in the spectrum analyzer to compensate the RF cable loss and attenuator factor between EUT conducted output port and spectrum analyzer. With the offset compensation, the spectrum analyzer reading level is exactly the EUT RF output level.

The spectrum analyzer offset is derived from RF cable loss and attenuator factor.

*Offset = RF cable loss + attenuator factor.*

Following shows an offset computation example with cable loss 4.0 dB and 10dB attenuator.

Example :

$$\begin{aligned} \text{Offset(dB)} &= \text{RF cable loss(dB)} + \text{attenuator factor(dB)}. \\ &= 4.0 + 10 = 14.0 \text{ (dB)} \end{aligned}$$



### 2.5 Frequency List of Low/Middle/High Channels

LTE Band 13 Channel and Frequency List				
BW [MHz]	Channel/Frequency(MHz)	Lowest	Middle	Highest
10	Channel	-	23230	-
	Frequency	-	782	-
5	Channel	23205	23230	23255
	Frequency	779.5	782	784.5

LTE Band 41 Channel and Frequency List				
BW [MHz]	Channel/Frequency(MHz)	Lowest	Middle	Highest
20	Channel	39750	40620	41490
	Frequency	2506	2593	2680
15	Channel	39725	40620	41515
	Frequency	2503.5	2593	2682.5
10	Channel	39700	40620	41540
	Frequency	2501	2593	2685
5	Channel	39675	40620	41565
	Frequency	2498.5	2593	2687.5

### 3 Conducted Test Items

#### 3.1 Measuring Instruments

See list of measuring instruments of this test report.

#### 3.2 Test Setup

##### 3.2.1 Conducted Output Power

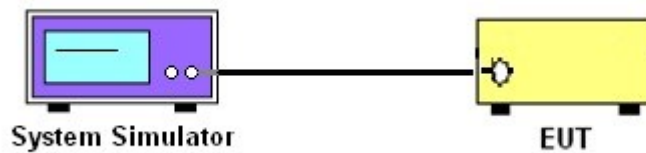

##### 3.2.2 Peak-to-Average Ratio, Occupied Bandwidth ,Conducted Band-Edge and Conducted Spurious Emission

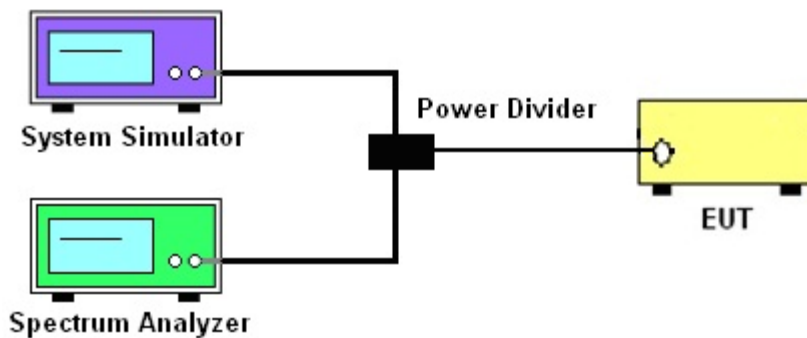

##### 3.2.3 Frequency Stability

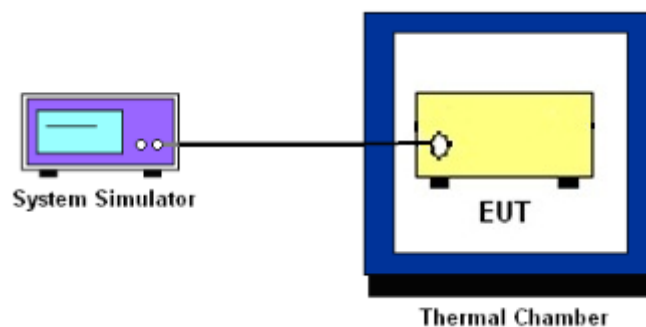

### 3.3 Test Result of Conducted Test

Please refer to Appendix A.



### 3.4 Conducted Output Power and ERP/EIRP

#### 3.4.1 Description of the Conducted Output Power Measurement and ERP/EIRP Measurement

A system simulator was used to establish communication with the EUT. Its parameters were set to force the EUT transmitting at maximum output power. The measured power in the radio frequency on the transmitter output terminals shall be reported.

The ERP of mobile transmitters must not exceed 7 Watts for LTE Band 5 and Band 26.

The ERP of mobile transmitters must not exceed 3 Watts for LTE Band 12, Band 13 and Band 17 and Band 71.

The EIRP of mobile transmitters must not exceed 2 Watts for LTE Band 2 and Band 25 and Band 7 and Band 38 and Band 41.

The EIRP of mobile transmitters must not exceed 1 Watts for LTE Band 4 and Band 66.

According to KDB 412172 D01 Power Approach,

$EIRP = P_T + G_T - L_C$ ,  $ERP = EIRP - 2.15$ , where

$P_T$  = transmitter output power in dBm

$G_T$  = gain of the transmitting antenna in dBi

$L_C$  = signal attenuation in the connecting cable between the transmitter and antenna in dB

#### 3.4.2 Test Procedures

1. The testing follows ANSI C63.26 Section 5.2
2. The transmitter output port was connected to the system simulator.
3. Set EUT at maximum power through the system simulator.
4. Select lowest, middle, and highest channels for each band and different modulation.
5. Measure and record the power level from the system simulator.



## **3.5 Peak-to-Average Ratio**

### **3.5.1 Description of the PAR Measurement**

Power Complementary Cumulative Distribution Function (CCDF) curves provide a means for characterizing the power peaks of a digitally modulated signal on a statistical basis. A CCDF curve depicts the probability of the peak signal amplitude exceeding the average power level. Most contemporary measurement instrumentation include the capability to produce CCDF curves for an input signal provided that the instrument's resolution bandwidth can be set wide enough to accommodate the entire input signal bandwidth. In measuring transmissions in this band using an average power technique, the peak-to-average ratio (PAR) of the transmission may not exceed 13 dB.

### **3.5.2 Test Procedures**

1. The testing follows ANSI C63.26 Section 5.2.3.4 (CCDF).
2. The EUT was connected to spectrum and system simulator via a power divider.
3. Set the CCDF (Complementary Cumulative Distribution Function) option in spectrum analyzer.
4. The highest RF powers were measured and recorded the maximum PAPR level associated with a probability of 0.1 %.
5. Record the deviation as Peak to Average Ratio.



### **3.6 Occupied Bandwidth**

#### **3.6.1 Description of Occupied Bandwidth Measurement**

The occupied bandwidth is the width of a frequency band such that, below the lower and above the upper frequency limits, the mean powers emitted are each equal to a specified percentage 0.5% of the total mean transmitted power.

The 26 dB emission bandwidth is defined as the frequency range between two points, one above and one below the carrier frequency, at which the spectral density of the emission is attenuated 26 dB below the maximum in-band spectral density of the modulated signal. Spectral density (power per unit bandwidth) is to be measured with a detector of resolution bandwidth equal to approximately 1.0% of the emission bandwidth.

#### **3.6.2 Test Procedures**

1. The testing follows ANSI C63.26 Section 5.4
2. The EUT was connected to spectrum analyzer and system simulator via a power divider.
3. The spectrum analyzer center frequency is set to the nominal EUT channel center frequency. The span range for the spectrum analyzer shall be between two and five times the anticipated OBW.
4. The nominal resolution bandwidth (RBW) shall be in the range of 1 to 5 % of the anticipated OBW, and the VBW shall be at least 3 times the RBW.
5. Set the detection mode to peak, and the trace mode to max hold.
6. Determine the reference value: Set the EUT to transmit a modulated signal. Allow the trace to stabilize. Set the spectrum analyzer marker to the highest level of the displayed trace.  
(this is the reference value)
7. Determine the “-26 dB down amplitude” as equal to (Reference Value – X).
8. Place two markers, one at the lowest and the other at the highest frequency of the envelope of the spectral display such that each marker is at or slightly below the “-X dB down amplitude” determined in step 6. If a marker is below this “-X dB down amplitude” value it shall be placed as close as possible to this value. The OBW is the positive frequency difference between the two markers.
9. Use the 99 % power bandwidth function of the spectrum analyzer and report the measured bandwidth.



### 3.7 Conducted Band Edge

#### 3.7.1 Description of Conducted Band Edge Measurement

22.917(a)

For operations in the 824 – 849 MHz band, the FCC limit is  $43 + 10\log_{10}(P[\text{Watts}])$  dB below the transmitter power  $P(\text{Watts})$  in a 100kHz bandwidth. However, in the 1MHz bands immediately outside and adjacent to the licensee's frequency block, a resolution bandwidth of at least one percent of the emission bandwidth of the fundamental emission of the transmitter may be employed.

24.238 (a)

For operations in the 1850-1910 and 1930-1990 MHz band, the FCC limit is  $43 + 10\log_{10}(P[\text{Watts}])$  dB below the transmitter power  $P(\text{Watts})$  in a 1MHz bandwidth. However, in the 1 MHz bands immediately outside and adjacent to the frequency block a resolution bandwidth of at least one percent of the emission bandwidth of the fundamental emission of the transmitter may be employed.

27.53 (c)

For operations in the 776-788 MHz band, the FCC limit is  $43 + 10\log_{10}(P[\text{Watts}])$  dB below the transmitter power  $P(\text{Watts})$  in a 100 kHz bandwidth. However, in the 100 kHz bands immediately outside and adjacent to the frequency block, a resolution bandwidth of at least 30 kHz may be employed. In addition, the power of any unwanted emissions in any 6.25 kHz bandwidth for all frequencies between 763-775 MHz and 793-806 MHz shall be attenuated below the transmitter power,  $P$  (dBW), by at least  $65 + 10 \log_{10} p(\text{watts})$ , dB, for mobile and portable equipment.

27.53 (g)

For operations in the 600MHz band and 698 -746 MHz band, the FCC limit is  $43 + 10\log_{10}(P[\text{Watts}])$  dB below the transmitter power  $P(\text{Watts})$  in a 100 kHz bandwidth. However, in the 100 kilohertz bands immediately outside and adjacent to a licensee's frequency block, a resolution bandwidth of at least 30 kHz may be employed.

27.53 (h)

For operations in the 1710 – 1755 MHz band, the FCC limit is  $43 + 10\log_{10}(P[\text{Watts}])$  dB below the transmitter power  $P(\text{Watts})$  in a 1 MHz bandwidth. However, in the 1MHz bands immediately outside and adjacent to the licensee's frequency block, a resolution bandwidth of at least one percent of the emission bandwidth of the fundamental emission of the transmitter may be employed.





27.53(m)(4)

For mobile digital stations, the attenuation factor shall be not less than  $40 + 10 \log (P)$  dB on all frequencies between the channel edge and 5 megahertz from the channel edge,  $43 + 10 \log (P)$  dB on all frequencies between 5 megahertz and X megahertz from the channel edge, and  $55 + 10 \log (P)$  dB on all frequencies more than X megahertz from the channel edge, where X is the greater of 6 megahertz or the actual emission bandwidth as defined in paragraph (m)(6) of this section. In addition, the attenuation factor shall not be less that  $43 + 10 \log (P)$  dB on all frequencies between 2490.5 MHz and 2496 MHz and  $55 + 10 \log (P)$  dB at or below 2490.5 MHz. Mobile Satellite Service licensees operating on frequencies below 2495 MHz may also submit a documented interference complaint against BRS licensees operating on channel BRS Channel 1 on the same terms and conditions as adjacent channel BRS or EBS licensees.

### 3.7.2 Test Procedures

1. The testing follows ANSI C63.26 section 5.7
2. The EUT was connected to spectrum analyzer and system simulator via a power divider.
3. The band edges of low and high channels for the highest RF powers were measured.
4. Set RBW  $\geq 1\%$  EBW in the 1MHz band immediately outside and adjacent to the band edge.
5. Beyond the 1 MHz band from the band edge, RBW=1MHz was used
6. Set spectrum analyzer with RMS detector.
7. The RF fundamental frequency should be excluded against the limit line in the operating frequency band.
8. Checked that all the results comply with the emission limit line.

Example:

The limit line is derived from  $43 + 10\log(P)$ dB below the transmitter power P(Watts)  
=  $P(W) - [43 + 10\log(P)]$  (dB)  
=  $[30 + 10\log(P)]$  (dBm) -  $[43 + 10\log(P)]$  (dB) = -13dBm.

9. For LTE Band 7,41, the other 40 dB, and 55 dB have additionally applied same calculation above.



### 3.8 Conducted Spurious Emission

#### 3.8.1 Description of Conducted Spurious Emission Measurement

The power of any emission outside of the authorized operating frequency ranges must be lower than the transmitter power (P) by a factor of at least  $43 + 10 \log (P)$  dB.

For Band 7,38,41:

The power of any emission outside of the authorized operating frequency ranges must be lower than the transmitter power (P) by a factor of at least  $55 + 10 \log (P)$  dB.

It is measured by means of a calibrated spectrum analyzer and scanned from 30 MHz up to a frequency including its 10<sup>th</sup> harmonic.

#### 3.8.2 Test Procedures

1. The testing follows ANSI C63.26 section 5.7
2. The EUT was connected to spectrum analyzer and system simulator via a power divider.
3. The RF output of EUT was connected to the spectrum analyzer by RF cable and attenuator. The path loss was compensated to the results for each measurement.
4. The middle channel for the highest RF power within the transmitting frequency was measured.
5. The conducted spurious emission for the whole frequency range was taken.
6. Make the measurement with the spectrum analyzer's RBW = 1MHz, VBW = 3MHz.
7. Set spectrum analyzer with RMS detector.
8. Taking the record of maximum spurious emission.
9. The RF fundamental frequency should be excluded against the limit line in the operating frequency band.
10. The limit line is derived from  $43 + 10\log(P)$ dB below the transmitter power P(Watts)  
=  $P(W) - [43 + 10\log(P)]$  (dB)  
=  $[30 + 10\log(P)]$  (dBm) -  $[43 + 10\log(P)]$  (dB)  
= -13dBm.
11. For Band 7, 38, 41  
The limit line is derived from  $55 + 10\log(P)$ dB below the transmitter power P(Watts)  
=  $P(W) - [55 + 10\log(P)]$  (dB)  
=  $[30 + 10\log(P)]$  (dBm) -  $[55 + 10\log(P)]$  (dB)  
= -25dBm.



## 3.9 Frequency Stability

### 3.9.1 Description of Frequency Stability Measurement

The frequency stability shall be measured by variation of ambient temperature and variation of primary supply voltage to ensure that the fundamental emission stays within the authorized frequency block. The frequency stability of the transmitter shall be maintained within  $\pm 0.00025\%$  ( $\pm 2.5\text{ppm}$ ) of the center frequency.

### 3.9.2 Test Procedures for Temperature Variation

1. The testing follows ANSI C63.26 section 5.6.4
2. The EUT was set up in the thermal chamber and connected with the system simulator.
3. With power OFF, the temperature was decreased to  $-30^{\circ}\text{C}$  and the EUT was stabilized before testing. Power was applied and the maximum change in frequency was recorded within one minute.
4. With power OFF, the temperature was raised in  $10^{\circ}\text{C}$  step up to  $50^{\circ}\text{C}$ . The EUT was stabilized at each step for at least half an hour. Power was applied and the maximum frequency change was recorded within one minute.

### 3.9.3 Test Procedures for Voltage Variation

1. The testing follows ANSI C63.26 section 5.6.5
2. The EUT was placed in a temperature chamber at  $20\pm 5^{\circ}\text{C}$  and connected with the system simulator.
3. The power supply voltage to the EUT was varied from 85% to 115% of the nominal value for other than hand carried battery equipment.
4. For hand carried, battery powered equipment, reduce the primary ac or dc supply voltage to the battery operating end point, which shall be specified by the manufacturer.
5. The variation in frequency was measured for the worst case.

## 4 Radiated Test Items

### 4.1 Measuring Instruments

See list of measuring instruments of this test report.

### 4.2 Test Setup

#### 4.2.1 For radiated test from 30MHz to 1GHz

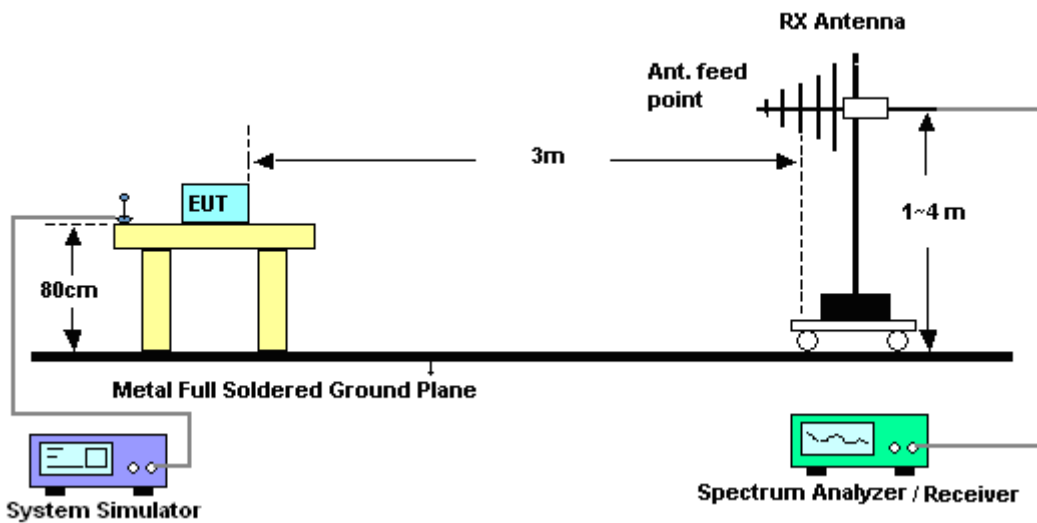

#### 4.2.2 For radiated test above 1GHz

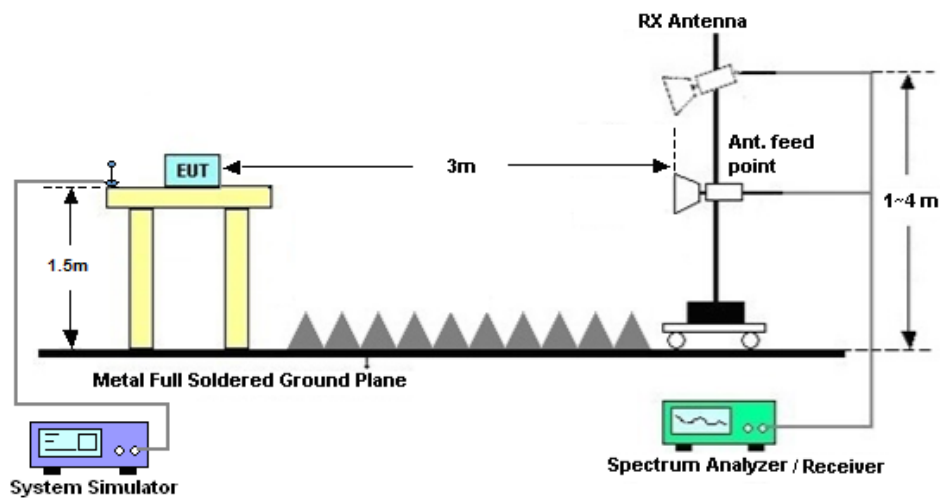

### 4.3 Test Result of Radiated Test

Please refer to Appendix B.



## 4.4 Radiated Spurious Emission

### 4.4.1 Description of Radiated Spurious Emission

The radiated spurious emission was measured by substitution method according to ANSI C63.26. The power of any emission outside of the authorized operating frequency ranges must be attenuated below the transmitter power (P) by a factor of at least  $43 + 10 \log (P)$  dB.

For Band 41

The power of any emission outside of the authorized operating frequency ranges must be attenuated below the transmitter power (P) by a factor of at least  $55 + 10 \log (P)$  dB.

For LTE Band 13

For operations in the 746-758 MHz, 775-788 MHz, and 805-806 MHz bands, emissions in the band 1559-1610 MHz shall be limited to  $-70$  dBW/MHz equivalent isotropically radiated power (EIRP) for wideband signals, and  $-80$  dBW EIRP for discrete emissions of less than 700 Hz bandwidth.

The spectrum is scanned from 30 MHz up to a frequency including its 10th harmonic.

### 4.4.2 Test Procedures

1. The testing follows ANSI C63.26 Section 5.5
2. The EUT was placed on a turntable with 0.8 meter height for frequency below 1GHz and 1.5 meter height for frequency above 1GHz respectively above ground.
3. The EUT was set 3 meters from the receiving antenna mounted on the antenna tower.
4. The table was rotated 360 degrees to determine the position of the highest spurious emission.
5. The height of the receiving antenna is varied between 1m to 4m to search the maximum spurious emission for both horizontal and vertical polarizations.
6. During the measurement, the system simulator parameters were set to force the EUT transmitting at maximum output power.
7. Make the measurement with the spectrum analyzer's RBW = 1MHz, VBW = 3MHz, taking the record of maximum spurious emission.
8. A horn antenna was substituted in place of the EUT and was driven by a signal generator.
9. Tune the output power of signal generator to the same emission level with EUT maximum spurious emission.
10.  $EIRP (dBm) = S.G. Power - Tx Cable Loss + Tx Antenna Gain$
11.  $ERP (dBm) = EIRP - 2.15$
12. The RF fundamental frequency should be excluded against the limit line in the operating frequency band.  
The limit line is derived from  $43 + 10\log(P)$ dB below the transmitter power P(Watts)  
 $= P(W) - [43 + 10\log(P)] (dB)$   
 $= [30 + 10\log(P)] (dBm) - [43 + 10\log(P)] (dB)$   
 $= -13dBm.$
13. For Band 7 , 41:  
The limit line is derived from  $55 + 10\log(P)$ dB below the transmitter power P(Watts)



## 5 List of Measuring Equipment

Instrument	Manufacturer	Model No.	Serial No.	Characteristics	Calibration Date	Test Date	Due Date	Remark
Spectrum Analyzer	R&S	FSV40	101078	9kHz~40GHz	Apr. 19, 2018	Sep. 06, 2018~ Sep. 07, 2018	Apr. 18, 2019	Conducted (TH01-SZ)
Thermal Chamber	Ten Billion Hongzhangroup	LP-150U	H2014081803	-40~+150°C	Dec. 26, 2017	Sep. 06, 2018~ Sep. 07, 2018	Dec. 25, 2018	Conducted (TH01-SZ)
EXA Spectrum Analyzer	KEYSIGHT	N9010A	MY55150246	10Hz~44GHz;	Apr. 19, 2018	Aug. 19, 2018~ Aug. 20, 2018	Apr. 18, 2019	Radiation (03CH03-SZ)
Bilog Antenna	TeseQ	CBL6112D	35408	30MHz-2GHz	Apr. 19, 2018	Aug. 19, 2018~ Aug. 20, 2018	Apr. 18, 2019	Radiation (03CH03-SZ)
Double Ridge Horn Antenna	SCHWARZBECK	BBHA9120D	9120D-1355	1GHz~18GHz	Mar. 29, 2018	Aug. 19, 2018~ Aug. 20, 2018	Mar. 28, 2019	Radiation (03CH03-SZ)
Amplifier	Burgeon	BPA-530	102210	0.01Hz ~3000MHz	Oct. 19, 2017	Aug. 19, 2018~ Aug. 20, 2018	Oct. 18, 2018	Radiation (03CH03-SZ)
HF Amplifier	MITEQ	TTA1840-35-HG	1871923	18GHz~40GHz	Jul. 30, 2018	Aug. 19, 2018~ Aug. 20, 2018	Jul. 30, 2019	Radiation (03CH03-SZ)
SHF-EHF Horn	com-power	AH-840	101071	18Ghz-40GHz	Mar. 30, 2018	Aug. 19, 2018~ Aug. 20, 2018	Mar. 29, 2019	Radiation (03CH03-SZ)
Amplifier	Agilent Technologies	83017A	MY39501302	500MHz~26.5GHz	Dec. 27, 2017	Aug. 19, 2018~ Aug. 20, 2018	Dec. 26, 2018	Radiation (03CH03-SZ)
AC Power Source	Chroma	61601	616010001985	N/A	NCR	Aug. 19, 2018~ Aug. 20, 2018	NCR	Radiation (03CH03-SZ)
Turn Table	EM	EM1000	N/A	0~360 degree	NCR	Aug. 19, 2018~ Aug. 20, 2018	NCR	Radiation (03CH03-SZ)
Antenna Mast	EM	EM1000	N/A	1 m~4 m	NCR	Aug. 19, 2018~ Aug. 20, 2018	NCR	Radiation (03CH03-SZ)
EXA Spectrum Analyzer	KEYSIGHT	N9010A	MY55150213	10Hz~44GHz	Apr. 19, 2018	Sep. 11, 2018	Apr. 18, 2019	Radiation (03CH04-SZ)
Bilog Antenna	TeseQ	CBL6111D	41909	30MHz~1GHz	Aug 28, 2018	Sep. 11, 2018	Aug. 27, 2019	Radiation (03CH04-SZ)
Double Ridge Horn Antenna	SCHWARZBECK	BBHA9120D	9120D-1285	1GHz~18GHz	Dec. 13, 2017	Sep. 11, 2018	Dec. 12, 2018	Radiation (03CH04-SZ)
Horn Antenna	SCHWARZBECK	BBHA9170	9170#679	15GHz~40GHz	Apr. 20, 2018	Sep. 11, 2018	Apr. 19, 2019	Radiation (03CH04-SZ)
Amplifier	Burgeon	BPA-530	102211	0.01Hz ~3000MHz	Oct. 19, 2017	Sep. 11, 2018	Oct. 18, 2018	Radiation (03CH04-SZ)
HF Amplifier	MITEQ	AMF-7D-00101800-30-10P-R	1989346	1GHz~18GHz	Jul. 30, 2018	Sep. 11, 2018	Jul. 29, 2019	Radiation (03CH04-SZ)
HF Amplifier	MITEQ	TTA1840-35-HG	1988315	18GHz~40GHz	Jul. 30, 2018	Sep. 11, 2018	Jul. 29, 2019	Radiation (03CH04-SZ)
Amplifier	Agilent Technologies	83017A	MY53270156	500MHz~26.5GHz	Apr. 19, 2018	Sep. 11, 2018	Apr. 18, 2019	Radiation (03CH04-SZ)
AC Power Source	Chroma	61601	N/A	N/A	NCR	Sep. 11, 2018	NCR	Radiation (03CH04-SZ)
Turn Table	EM	EM1000	N/A	0~360 degree	NCR	Sep. 11, 2018	NCR	Radiation (03CH04-SZ)
Antenna Mast	EM	EM1000	N/A	1 m~4 m	NCR	Sep. 11, 2018	NCR	Radiation (03CH04-SZ)

NCR: No Calibration Required



## 6 Uncertainty of Evaluation

### Uncertainty of Radiated Emission Measurement (30 MHz ~ 1000 MHz) for 03CH03-SZ

Measuring Uncertainty for a Level of Confidence of 95% (U = 2Uc(y))	3.0dB
---	-------

### Uncertainty of Radiated Emission Measurement (1 GHz ~ 18 GHz) for 03CH03-SZ

Measuring Uncertainty for a Level of Confidence of 95% (U = 2Uc(y))	3.6dB
---	-------

### Uncertainty of Radiated Emission Measurement (18 GHz ~ 40 GHz) for 03CH03-SZ

Measuring Uncertainty for a Level of Confidence of 95% (U = 2Uc(y))	3.8dB
---	-------

### Uncertainty of Radiated Emission Measurement (30 MHz ~ 1000 MHz) for 03CH04-SZ

Measuring Uncertainty for a Level of Confidence of 95% (U = 2Uc(y))	2.8dB
---	-------

### Uncertainty of Radiated Emission Measurement (1 GHz ~ 18 GHz) for 03CH04-SZ

Measuring Uncertainty for a Level of Confidence of 95% (U = 2Uc(y))	3.1dB
---	-------

### Uncertainty of Radiated Emission Measurement (18 GHz ~ 40 GHz) for 03CH04-SZ

Measuring Uncertainty for a Level of Confidence of 95% (U = 2Uc(y))	3.9dB
---	-------



## Appendix A. Test Results of Conducted Test

### Conducted Output Power(Average power)

LTE Band 13 Maximum Average Power [dBm]						
BW [MHz]	RB Size	RB Offset	Mod	Lowest	Middle	Highest
10	1	0	QPSK		24.41	
10	1	25			24.33	
10	1	49			24.25	
10	25	0			23.92	
10	25	12			23.91	
10	25	25			23.90	
10	50	0			23.91	
10	1	0	16-QAM		23.35	
10	1	25			23.28	
10	1	49			23.23	
10	25	0			22.41	
10	25	12			22.50	
10	25	25			22.36	
10	50	0			22.40	
10	1	0	64QAM		22.18	
10	1	25			22.24	
10	1	49			22.28	
10	25	0			21.10	
10	25	12			21.13	
10	25	25			21.13	
10	50	0			21.13	
5	1	0	QPSK	24.34	24.32	24.27
5	1	12		24.36	24.32	24.30
5	1	24		24.32	24.26	24.26
5	12	0		23.91	23.88	23.85
5	12	7		23.96	23.89	23.86
5	12	13		23.92	23.87	23.87
5	25	0		23.93	23.88	23.87





5	1	0	16-QAM	23.57	23.79	23.51
5	1	12		23.47	23.48	23.86
5	1	24		23.50	23.28	23.78
5	12	0		22.53	22.44	22.29
5	12	7		22.50	22.51	22.50
5	12	13		22.49	22.49	22.48
5	25	0		22.44	22.46	22.45
5	1	0	64QAM	22.22	22.22	22.22
5	1	12		22.28	22.25	22.18
5	1	24		22.25	22.21	22.25
5	12	0		21.20	21.19	21.13
5	12	7		21.22	21.18	21.17
5	12	13		21.17	21.17	21.15
5	25	0		21.12	21.12	21.09



**ERP/EIRP**

LTE Band 13 (G <sub>T</sub> - L <sub>C</sub> = -1.3 dBi) QPSK						
Bandwidth	5M			10M		
Channel	23205	23230	23255	23230		
	(Low)	(Mid)	(High)	-	(Mid)	-
Frequency	779.5	782	784.5	-	782	-
(MHz)						
Conducted Power (dBm)	24.36	24.32	24.30	-	24.41	-
Conducted Power (Watts)	0.2729	0.2704	0.2692	-	0.2761	-
ERP(dBm)	20.91	20.87	20.85	-	20.96	-
ERP(Watts)	0.1233	0.1222	0.1216	-	0.1247	-

LTE Band 13 (G <sub>T</sub> - L <sub>C</sub> = -1.3 dBi) 16QAM						
Bandwidth	5M			10M		
Channel	23205	23230	23255	23230		
	(Low)	(Mid)	(High)	-	(Mid)	-
Frequency	779.5	782	784.5	-	782	-
(MHz)						
Conducted Power (dBm)	23.47	23.48	23.86	-	23.35	-
Conducted Power (Watts)	0.2223	0.2228	0.2432	-	0.2163	-
ERP(dBm)	20.02	20.03	20.41	-	19.90	-
ERP(Watts)	0.1005	0.1007	0.1099	-	0.0977	-



LTE Band 13 (G <sub>T</sub> - L <sub>C</sub> = -1.3 dBi) 64QAM						
Bandwidth	5M			10M		
Channel	23205	23230	23255	23230		
	(Low)	(Mid)	(High)	-	(Mid)	-
Frequency (MHz)	779.5	782	784.5	-	782	-
Conducted Power (dBm)	22.28	22.25	22.18	-	22.28	-
Conducted Power (Watts)	0.1690	0.1679	0.1652	-	0.1690	-
ERP(dBm)	18.83	18.80	18.73	-	18.83	-
ERP(Watts)	0.0764	0.0759	0.0746	-	0.0764	-



**Peak-to-Average Ratio**

Mode	LTE Band 13 / 10MHz				
Mod.	QPSK		16QAM		Limit: 13dB
RB Size	1RB	Full RB	1RB	Full RB	Result
Lowest CH	-	-	-	-	<b>PASS</b>
Middle CH	3.25	4.55	4.64	5.83	
Highest CH	-	-	-	-	
Mode	LTE Band 13 / 10MHz				
Mod.	64QAM				Limit: 13dB
RB Size	1RB	Full RB			Result
Lowest CH	-	-	-	-	<b>PASS</b>
Middle CH	4.61	5.88	-	-	
Highest CH	-	-	-	-	



LTE Band 13 / 10MHz / QPSK

Middle Channel/ 1RB

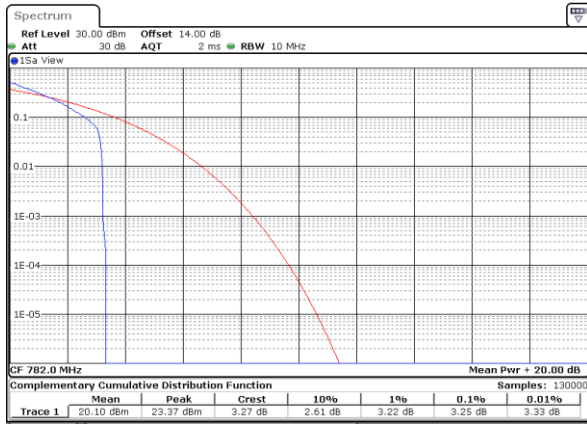

Date: 6 SEP 2018 12:12:15

Middle Channel / Full RB

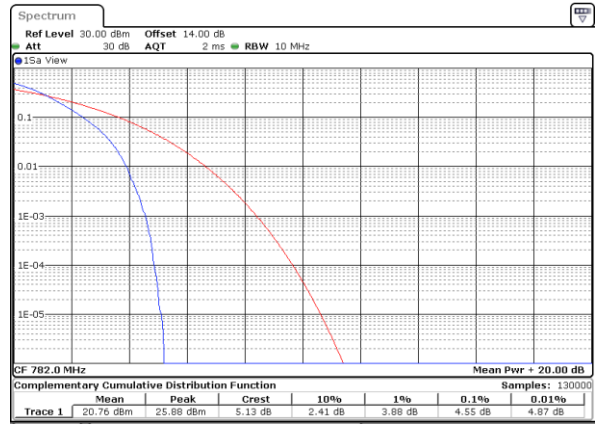

Date: 6 SEP 2018 12:12:25

LTE Band 13 / 10MHz / 16QAM

Middle Channel/ 1RB

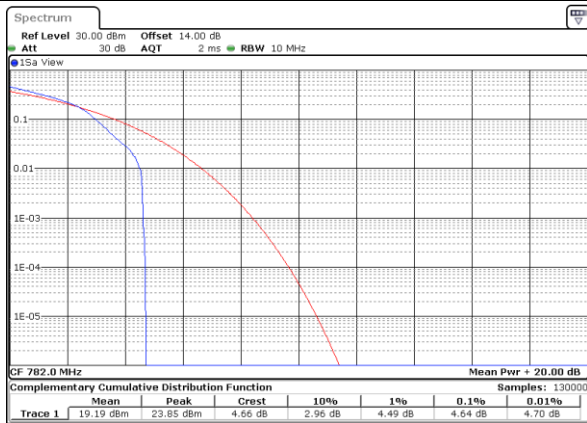

Date: 6 SEP 2018 11:57:52

Middle Channel / Full RB

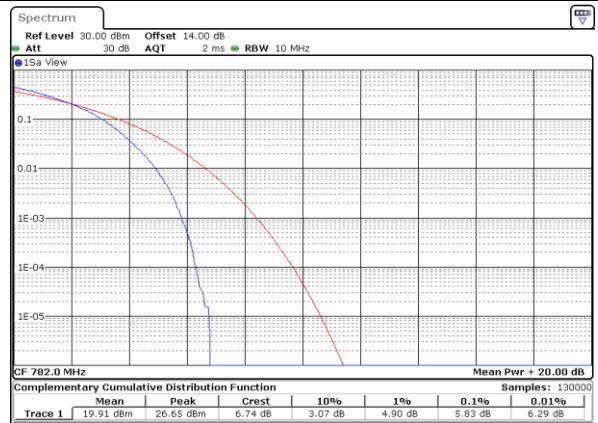

Date: 6 SEP 2018 12:12:06

LTE Band 13 / 10MHz / 64QAM

Middle Channel/ 1RB

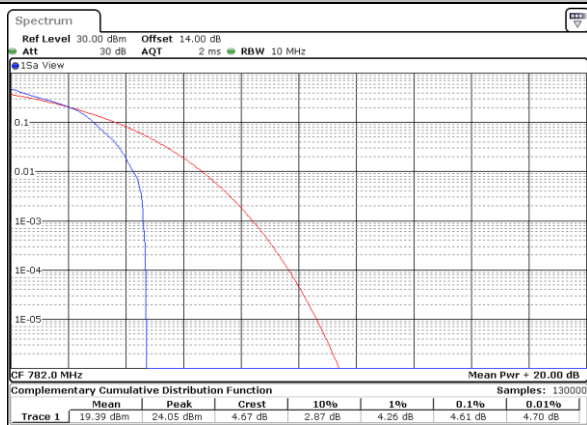

Date: 7 SEP 2018 16:10:12

Middle Channel / Full RB



Date: 7 SEP 2018 16:25:21



26dB Bandwidth

Mode	LTE Band 13 : 26dB BW(MHz)											
BW	1.4MHz		3MHz		5MHz		10MHz		15MHz		20MHz	
Mod.	QPSK	16QAM	QPSK	16QAM	QPSK	16QAM	QPSK	16QAM	QPSK	16QAM	QPSK	16QAM
Lowest CH	-	-	-	-	4.905	4.945	-	-	-	-	-	-
Middle CH	-	-	-	-	4.835	4.875	9.75	9.97	-	-	-	-
Highest CH	-	-	-	-	4.955	4.845	-	-	-	-	-	-
Mode	LTE Band 13 : 26dB BW(MHz)											
BW	1.4MHz		3MHz		5MHz		10MHz		15MHz		20MHz	
Mod.	64QAM		64QAM		64QAM		64QAM		64QAM		64QAM	
Lowest CH	-	-	-	-	4.855			-	-	-	-	-
Middle CH	-	-	-	-	4.925		9.69	-	-	-	-	-
Highest CH	-	-	-	-	4.925			-	-	-	-	-



LTE Band 13

Lowest Channel / 5MHz / QPSK

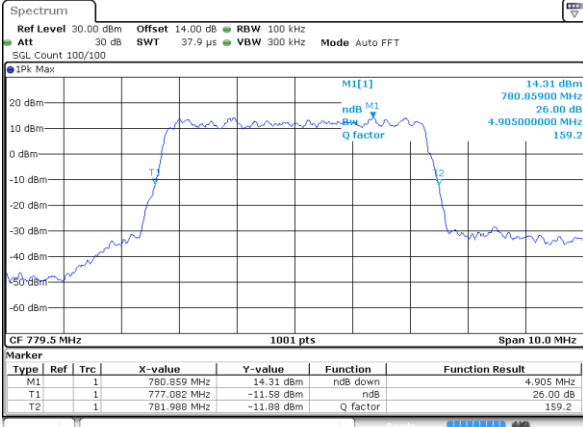

Date: 6 SEP 2018 11:18:24

Lowest Channel / 5MHz / 16QAM

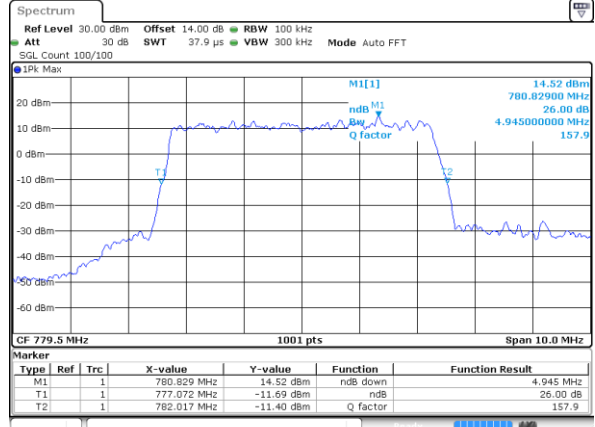

Date: 6 SEP 2018 11:18:33

Middle Channel / 5MHz / QPSK

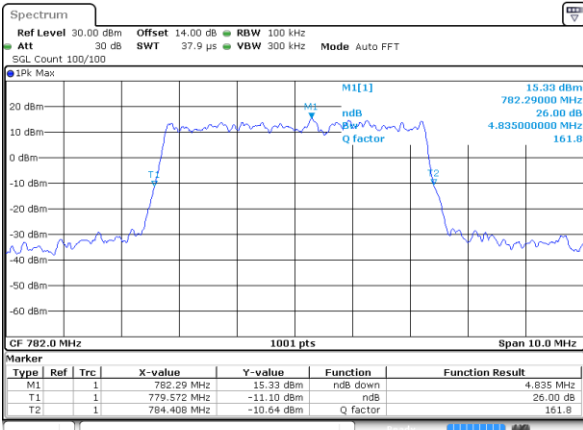

Date: 6 SEP 2018 11:27:22

Middle Channel / 5MHz / 16QAM

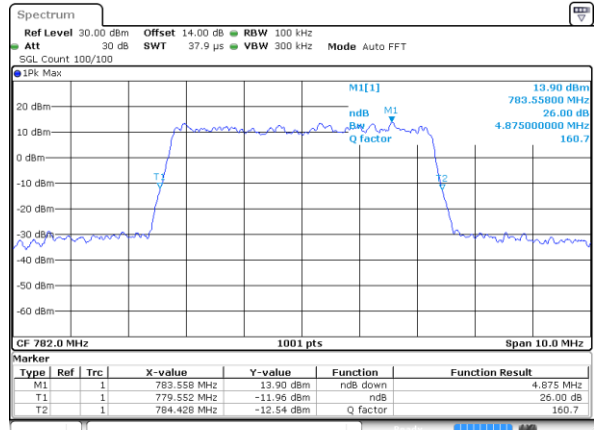

Date: 6 SEP 2018 11:27:31

Highest Channel / 5MHz / QPSK

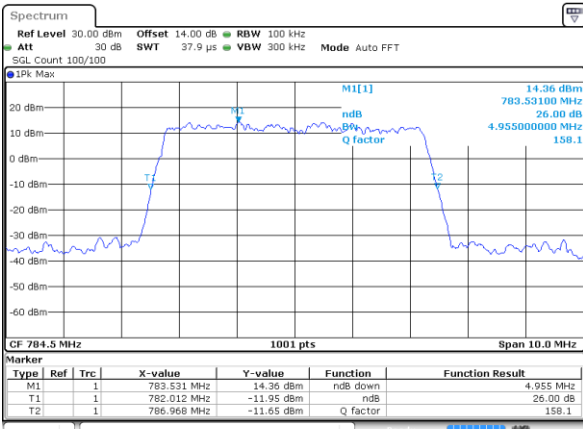

Date: 6 SEP 2018 11:29:47

Highest Channel / 5MHz / 16QAM

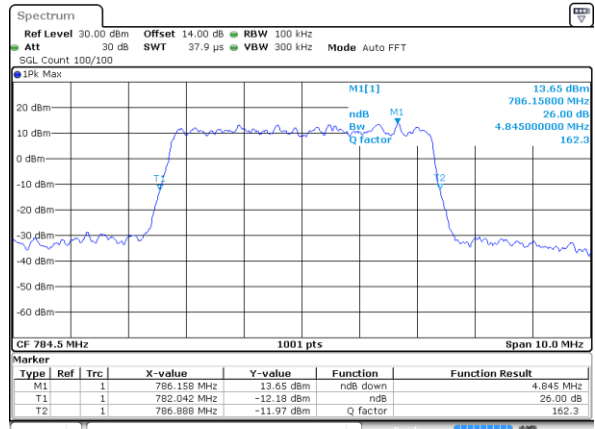

Date: 6 SEP 2018 11:29:57



LTE Band 13

Middle Channel / 10MHz / QPSK

Middle Channel / 10MHz / 16QAM

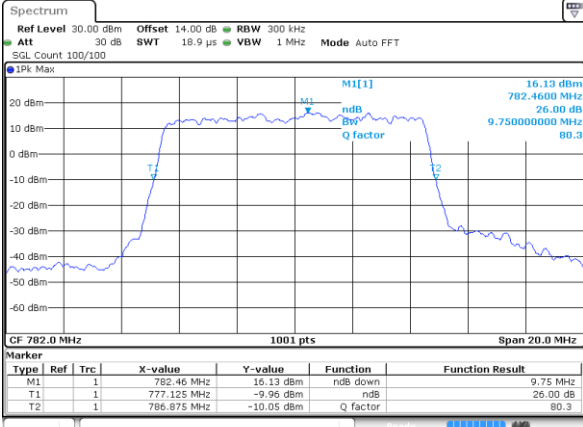

Date: 6 SEP 2018 11:38:44

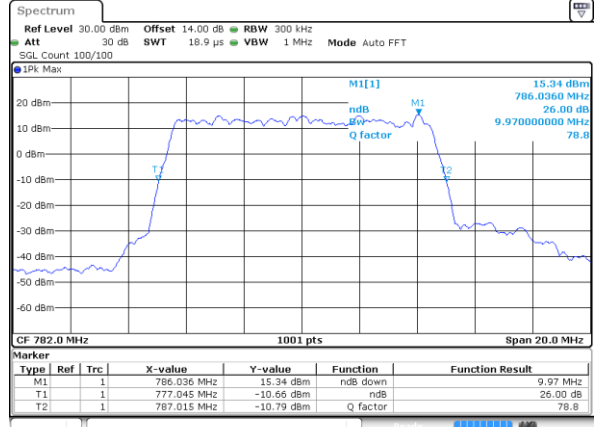

Date: 6 SEP 2018 11:38:54





LTE Band 13

Lowest Channel / 5MHz / 64QAM

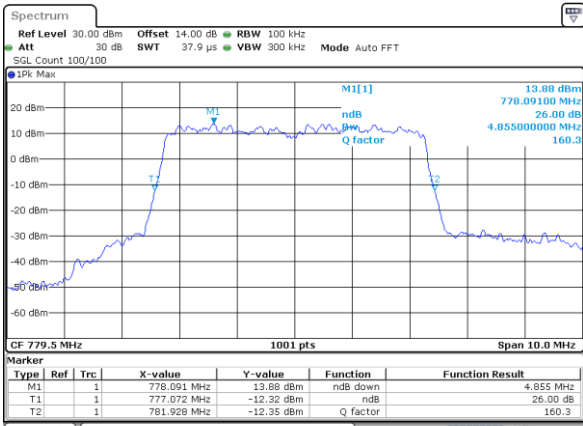

Date: 7 SEP 2018 15:53:17

Middle Channel / 5MHz / 64QAM

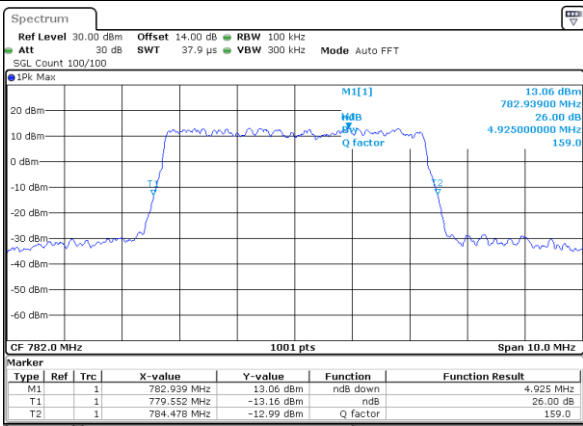

Date: 7 SEP 2018 15:57:46

Middle Channel / 5MHz / 64QAM

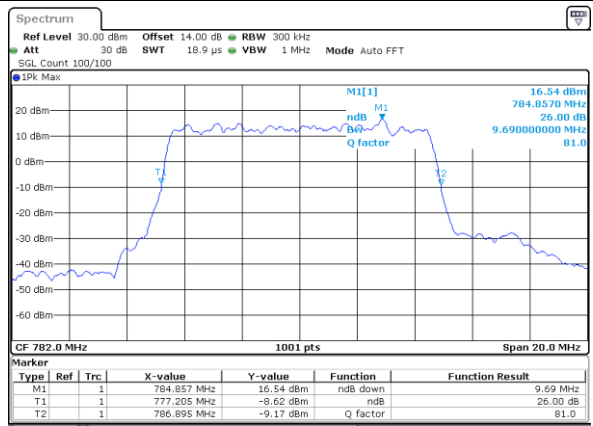

Date: 7 SEP 2018 16:03:27

Highest Channel / 5MHz / 64QAM

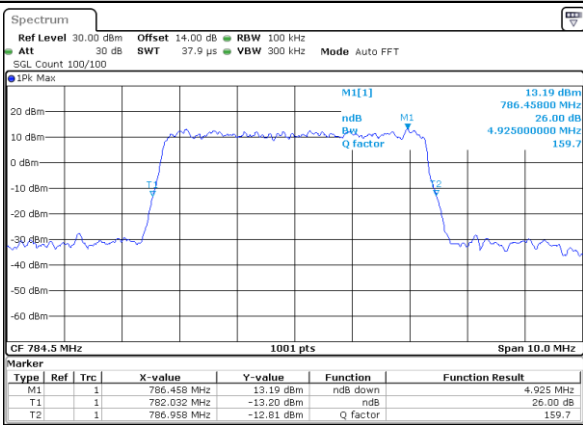

Date: 7 SEP 2018 15:58:58



### Occupied Bandwidth

Mode	LTE Band 13 : 99%OBW(MHz)											
BW	1.4MHz		3MHz		5MHz		10MHz		15MHz		20MHz	
Mod.	QPSK	16QAM	QPSK	16QAM	QPSK	16QAM	QPSK	16QAM	QPSK	16QAM	QPSK	16QAM
Lowest CH	-	-	-	-	4.51	4.51	-	-	-	-	-	-
Middle CH	-	-	-	-	4.5	4.49	9.01	9.05	-	-	-	-
Highest CH	-	-	-	-	4.47	4.5	-	-	-	-	-	-
Mode	LTE Band 13 : 99%OBW(MHz)											
BW	1.4MHz		3MHz		5MHz		10MHz		15MHz		20MHz	
Mod.	64QAM		64QAM		64QAM		64QAM		64QAM		64QAM	
Lowest CH					4.51							
Middle CH					4.51		8.97					
Highest CH					4.5							



LTE Band 13

Lowest Channel / 5MHz / QPSK

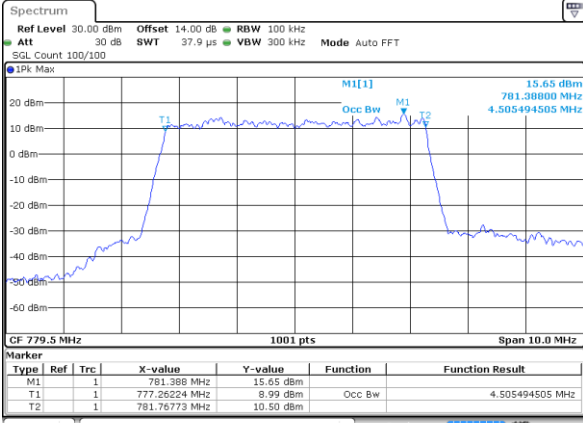

Date: 6 SEP 2018 11:18:04

Lowest Channel / 5MHz / 16QAM

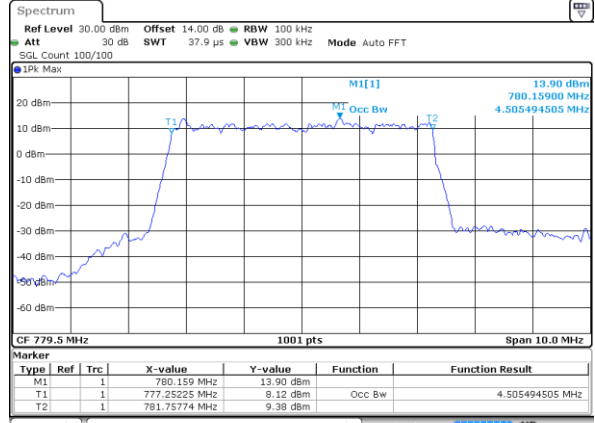

Date: 6 SEP 2018 11:18:14

Middle Channel / 5MHz / QPSK

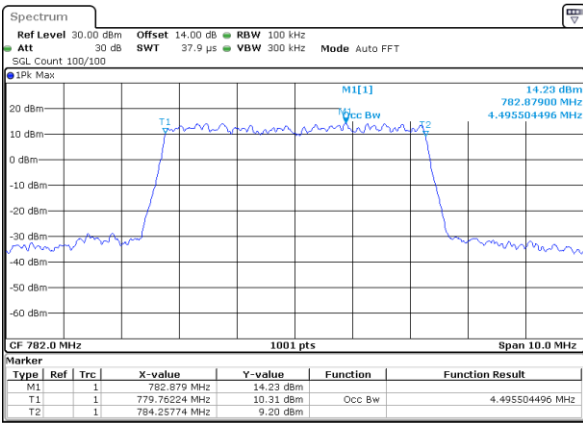

Date: 6 SEP 2018 11:27:02

Middle Channel / 5MHz / 16QAM

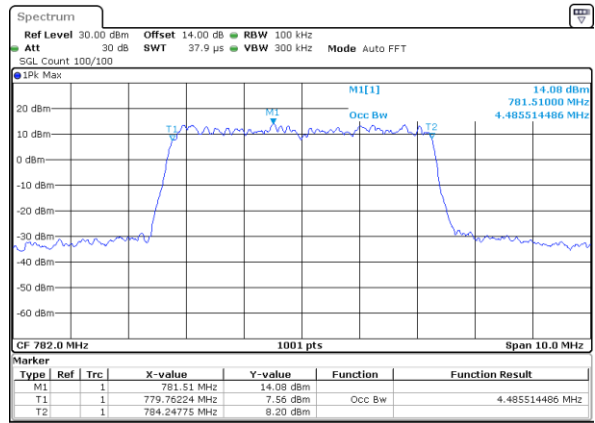

Date: 6 SEP 2018 11:27:12

Highest Channel / 5MHz / QPSK

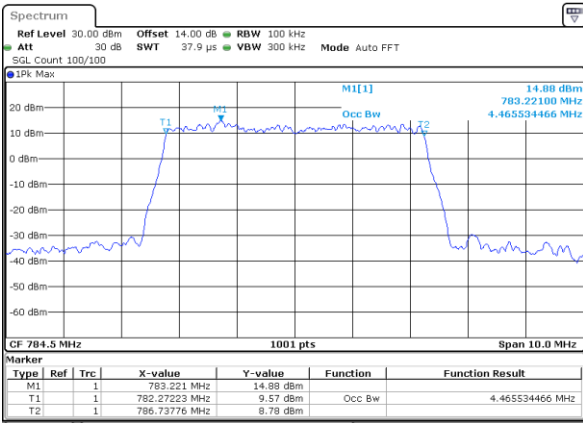

Date: 6 SEP 2018 11:29:27

Highest Channel / 5MHz / 16QAM

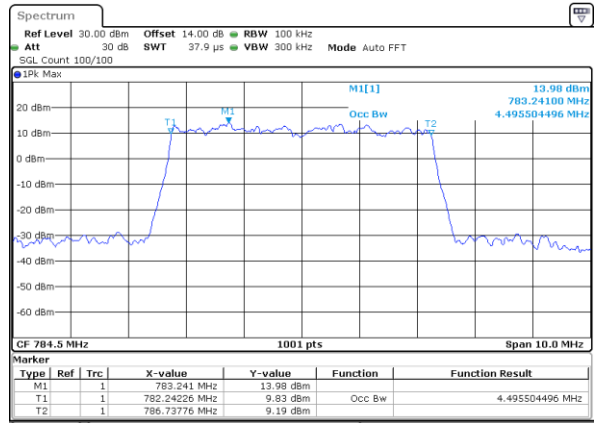

Date: 6 SEP 2018 11:29:37



LTE Band 13

Middle Channel / 10MHz / QPSK

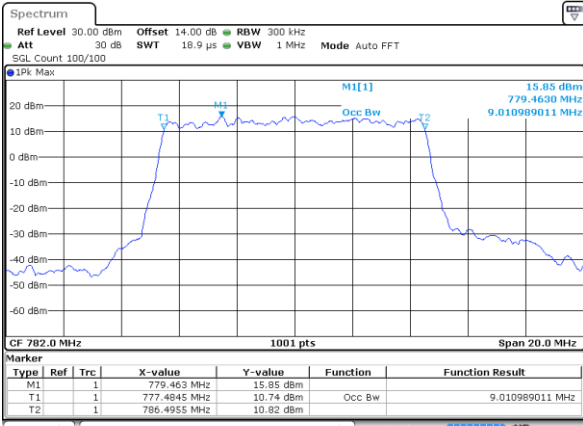

Date: 6 SEP 2018 11:38:24

Middle Channel / 10MHz / 16QAM

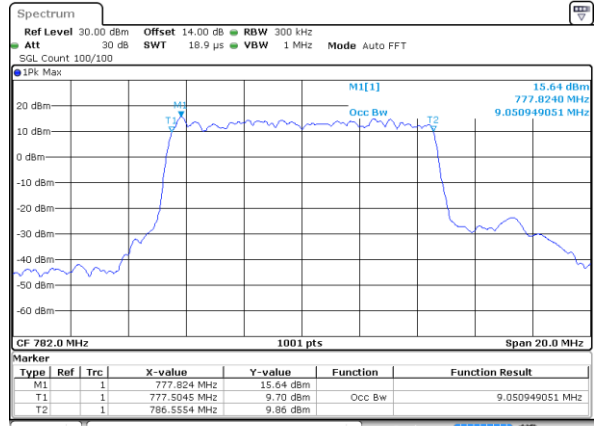

Date: 6 SEP 2018 11:38:34



LTE Band 13

Lowest Channel / 5MHz / 64QAM

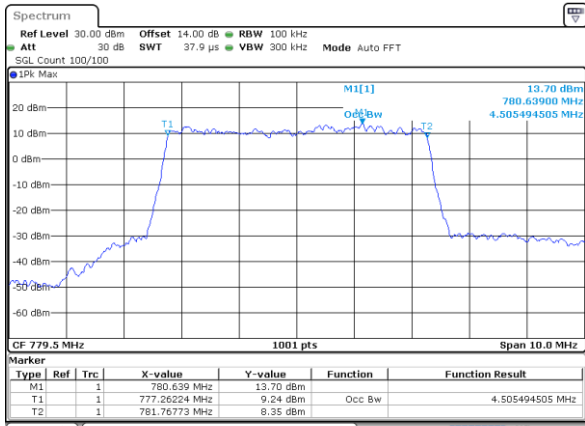

Date: 7 SEP 2018 15:53:07

Middle Channel / 5MHz / 64QAM

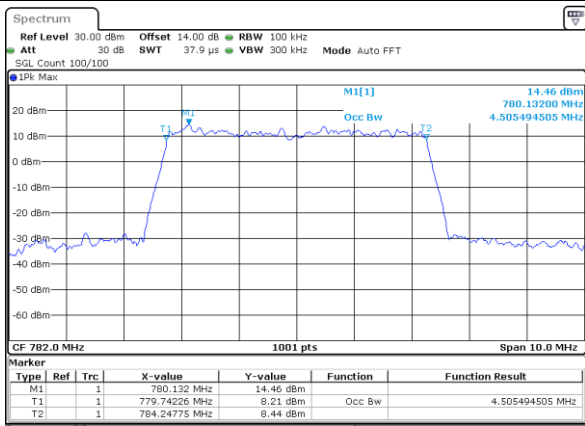

Date: 7 SEP 2018 15:57:36

Middle Channel / 10MHz / 64QAM

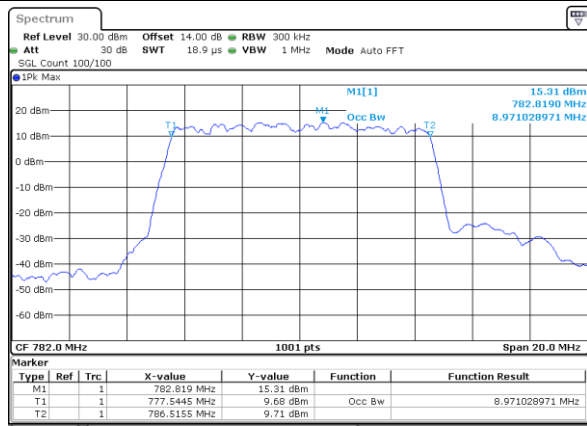

Date: 7 SEP 2018 16:03:17

Highest Channel / 5MHz / 64QAM

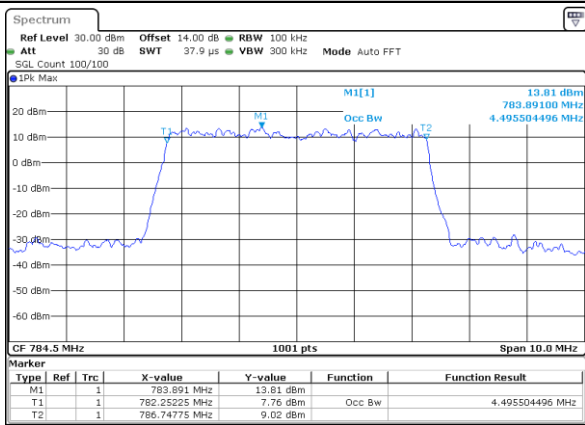

Date: 7 SEP 2018 15:58:48



# Conducted Band Edg

## LTE Band 13 / 5MHz / QPSK

### Lowest Band Edge / 1 RB

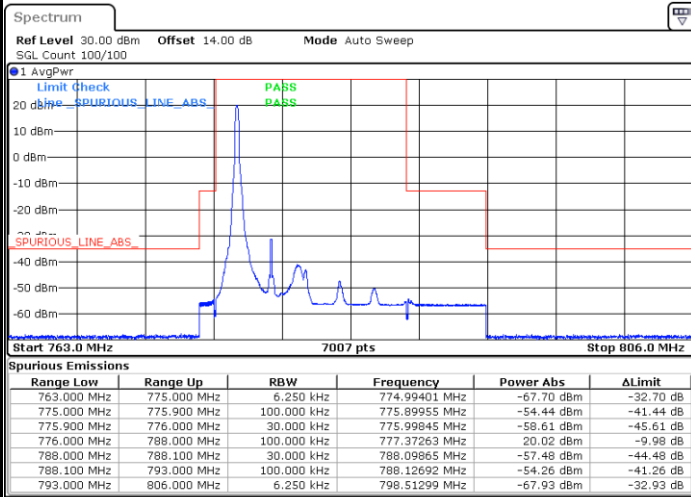

Date: 6 SEP.2018 11:20:11

### Highest Band Edge / 1 RB

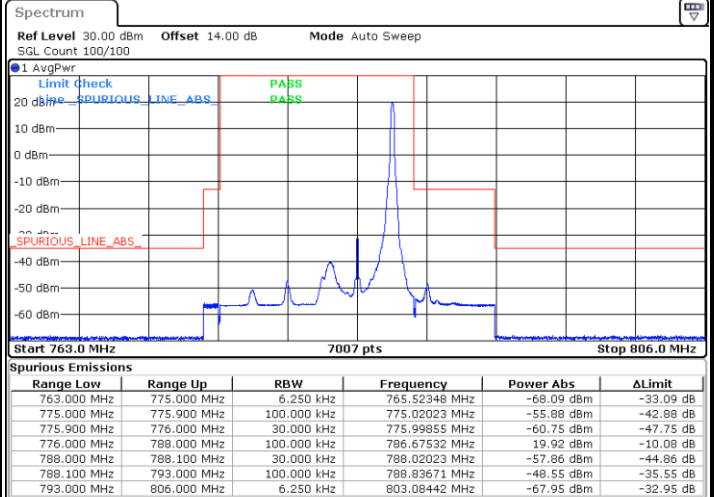

Date: 6 SEP.2018 11:31:35

### Lowest Band Edge / Full RB

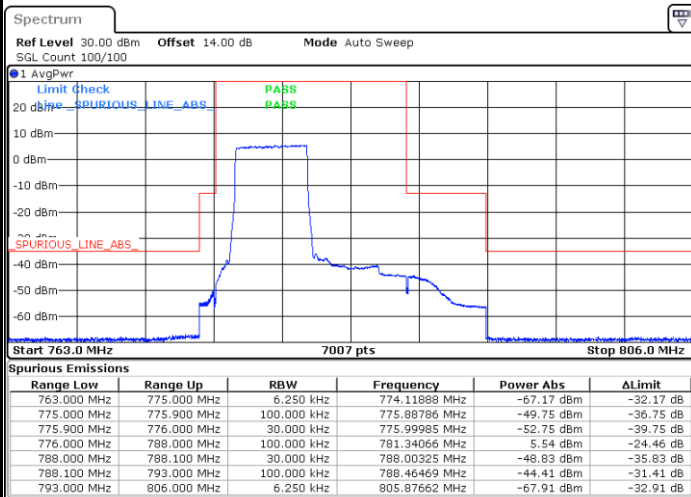

Date: 6 SEP.2018 11:23:28

### Highest Band Edge / Full RB

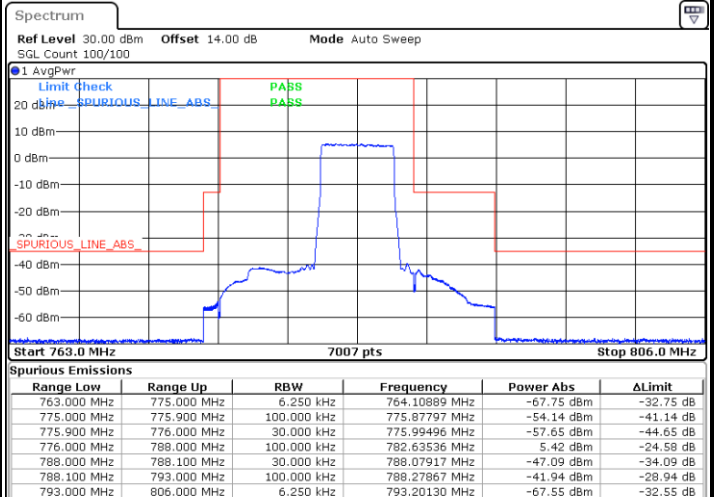

Date: 6 SEP.2018 11:34:50



LTE Band 13 / 5MHz / 16QAM

Lowest Band Edge / 1 RB

Highest Band Edge / 1 RB

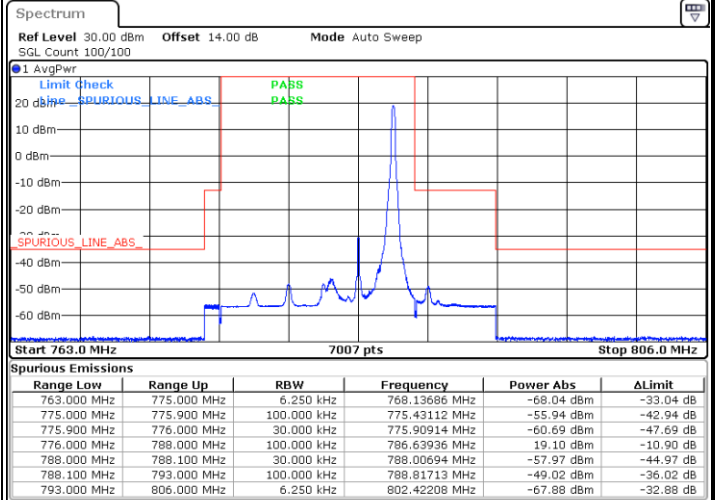
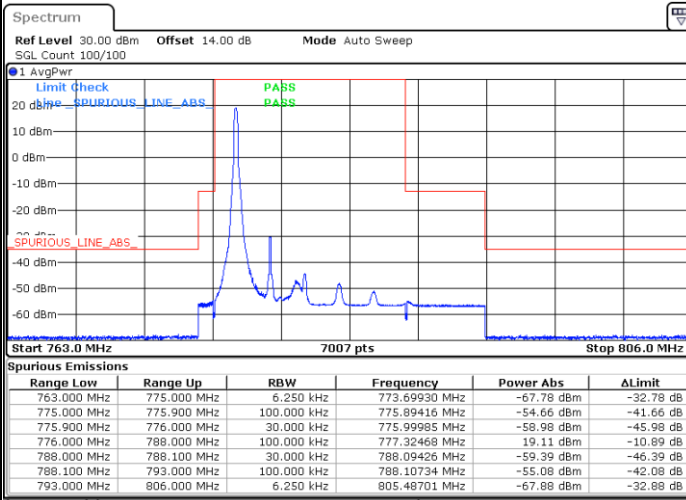

Date: 6 SEP.2018 11:21:50

Date: 6 SEP.2018 11:33:13

Lowest Band Edge / Full RB

Highest Band Edge / Full RB

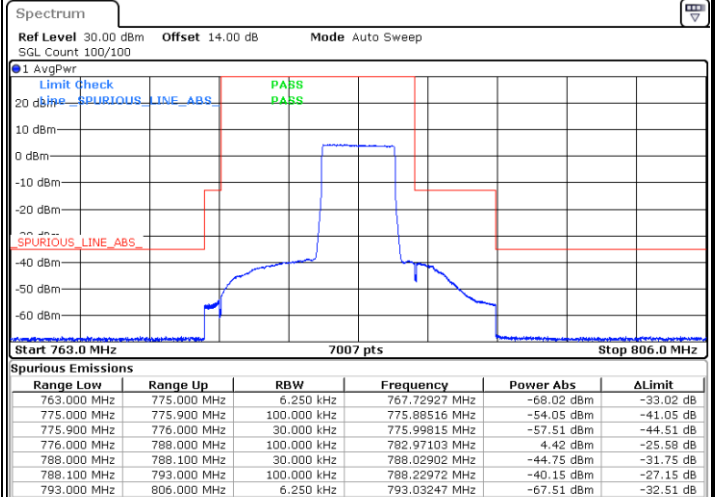
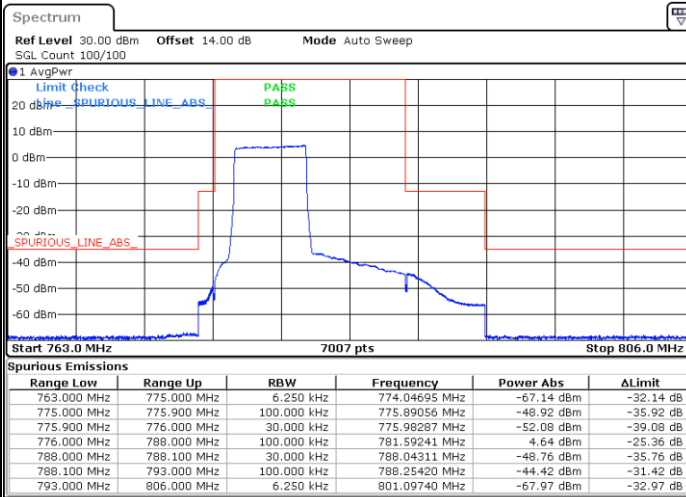

Date: 6 SEP.2018 11:25:06

Date: 6 SEP.2018 11:36:28



LTE Band 13 / 10MHz / QPSK

Band Edge / 1 RB0

Band Edge / 1 RB

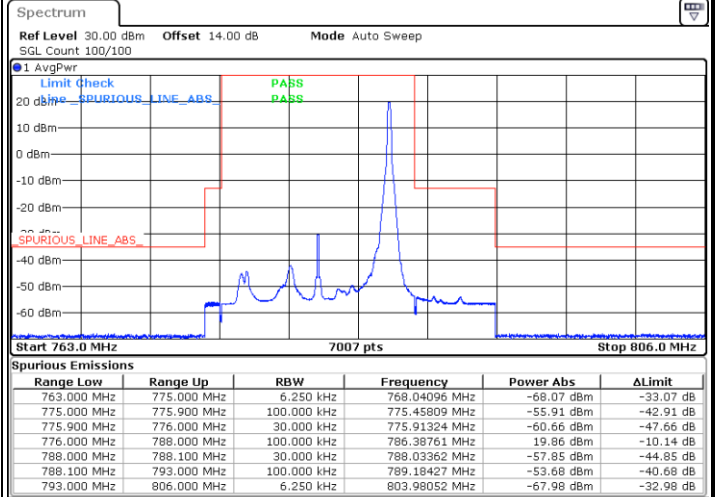
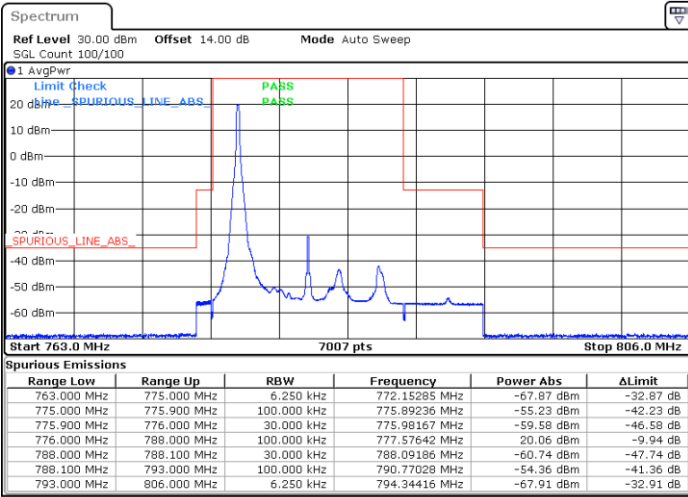

Date: 6 SEP.2018 11:40:32

Date: 6 SEP.2018 11:47:03

Band Edge / Full RB

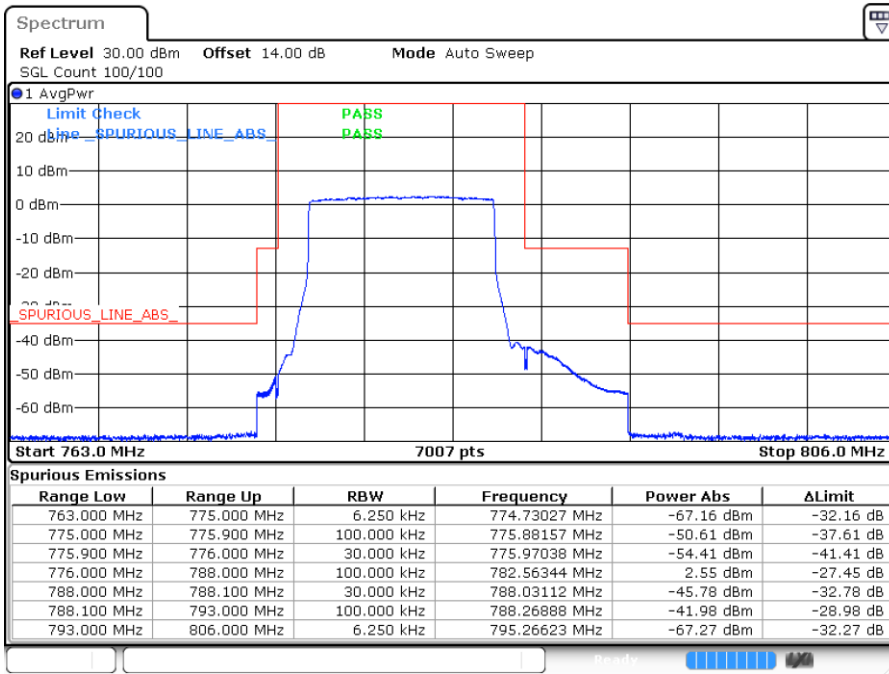

Date: 6 SEP.2018 11:43:48





LTE Band 13 / 10MHz / 16QAM

Band Edge / 1 RB0

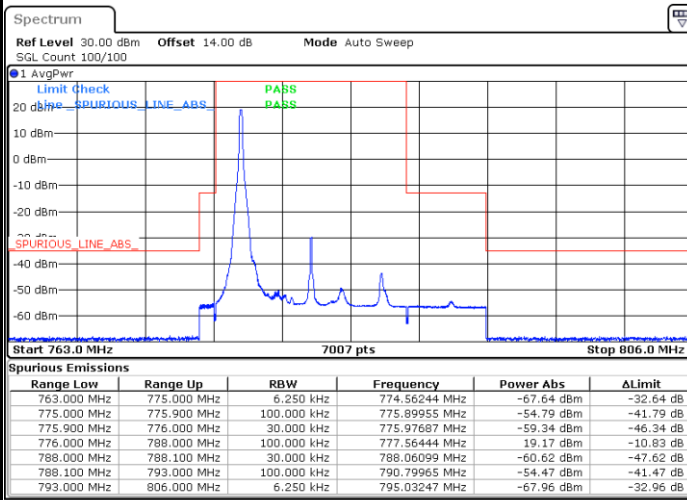

Date: 6 SEP.2018 11:42:10

Band Edge / 1 RB

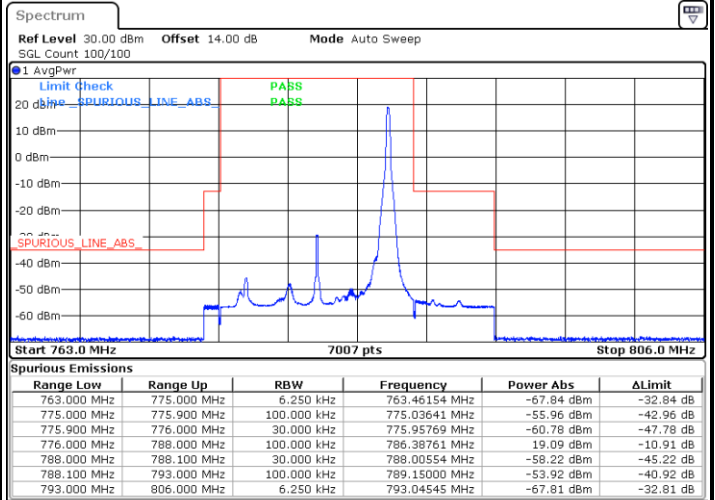

Date: 6 SEP.2018 11:48:41

Band Edge / Full RB

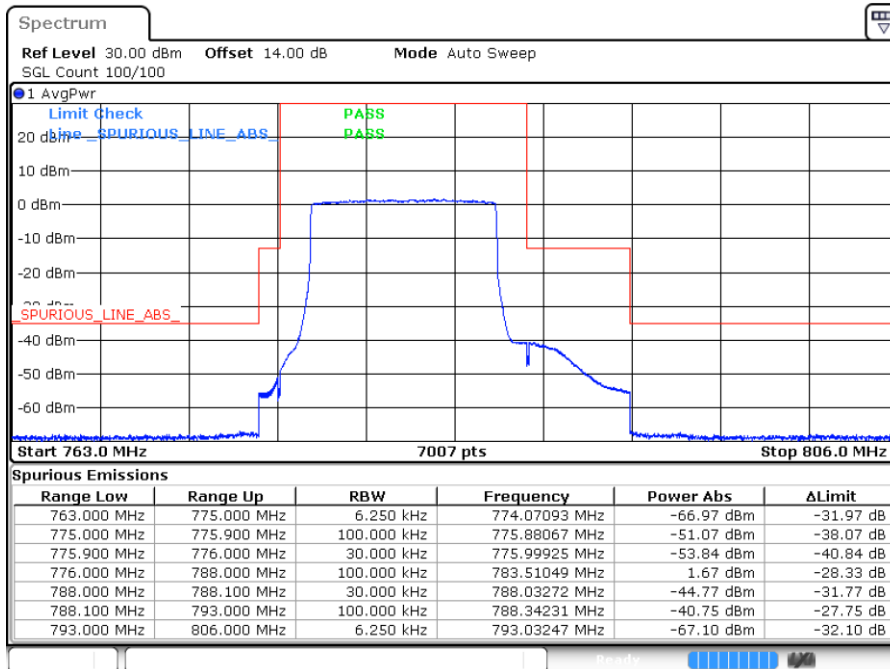

Date: 6 SEP.2018 11:45:26



LTE Band 13 / 5MHz / 64QAM

Lowest Band Edge / 1 RB

Highest Band Edge / 1 RB

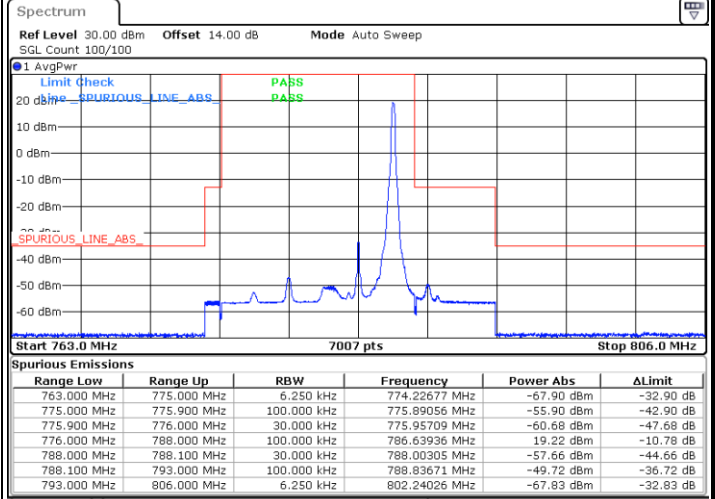
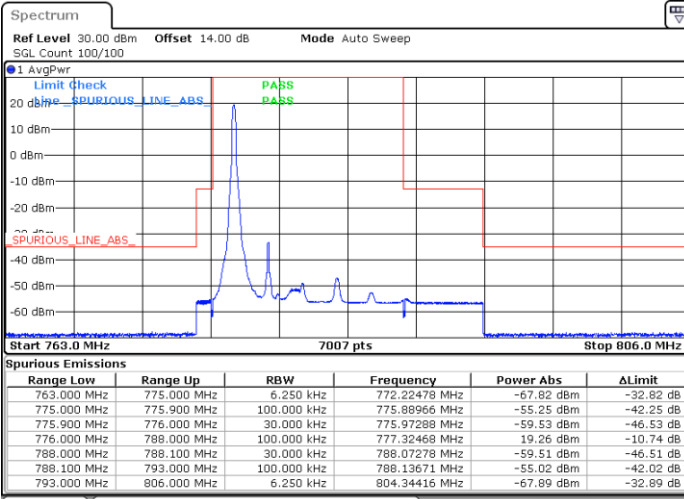

Date: 7.SEP.2018 15:54:55

Date: 7.SEP.2018 16:00:36

Lowest Band Edge / Full RB

Highest Band Edge / Full RB

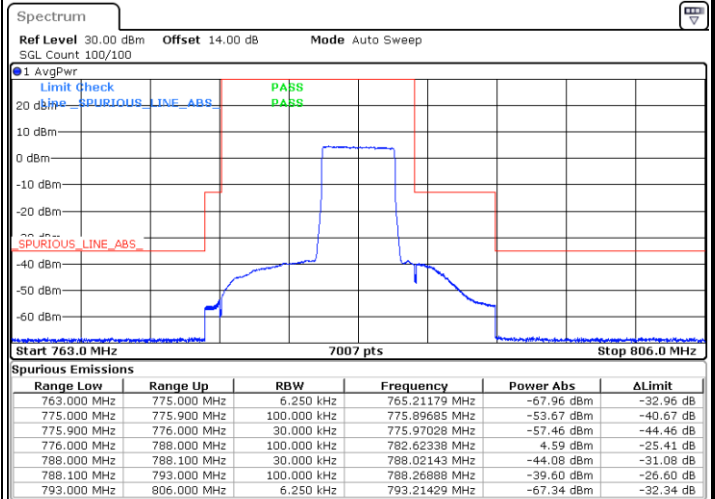
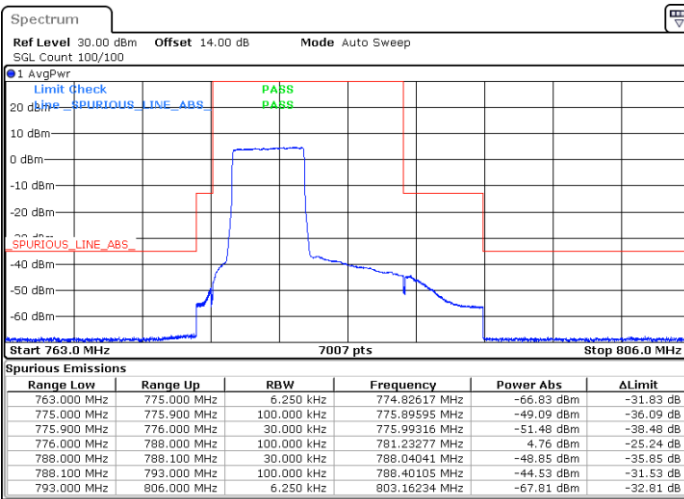

Date: 7.SEP.2018 15:56:33

Date: 7.SEP.2018 16:02:14



LTE Band 13 / 10MHz / 64QAM

Band Edge / 1 RB

Band Edge / 1 RB

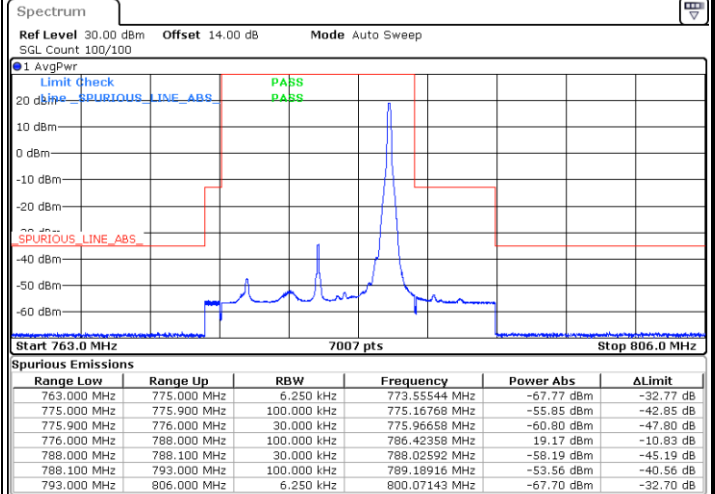
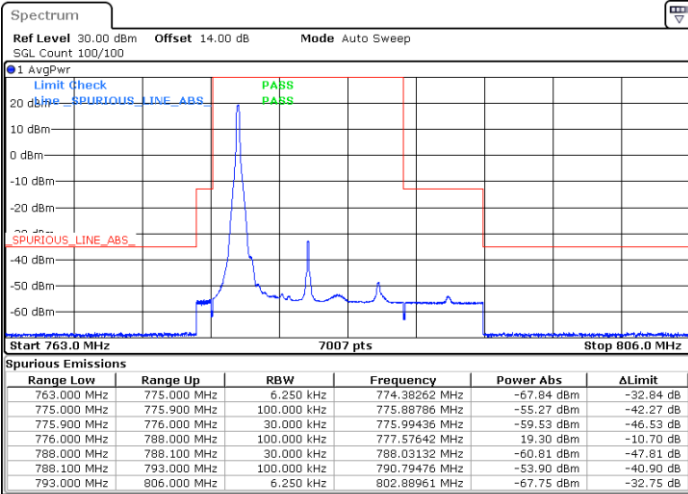

Date: 7 SEP 2018 16:05:05

Date: 7 SEP 2018 16:08:21

Band Edge / Full RB

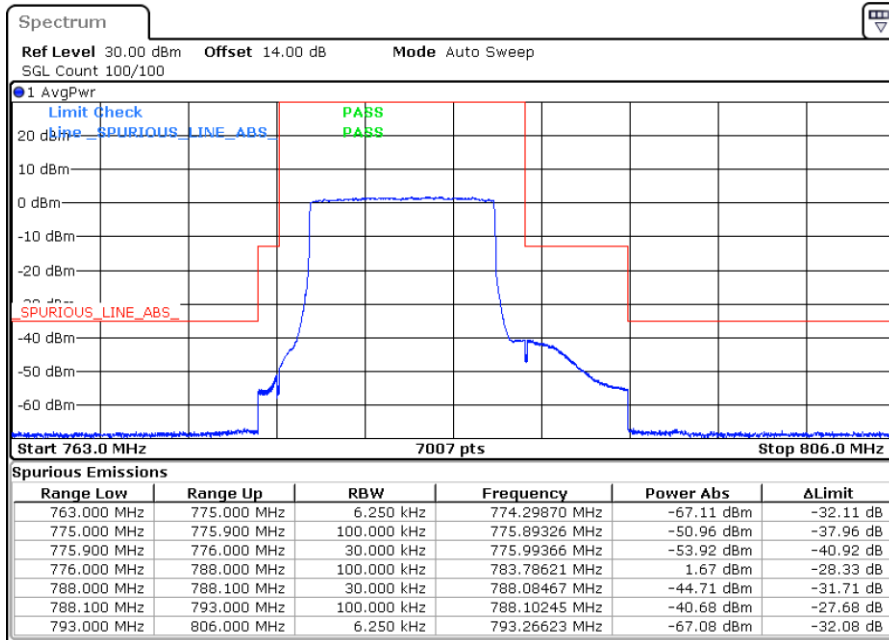

Date: 7 SEP 2018 16:06:43



# Conducted Spurious Emission

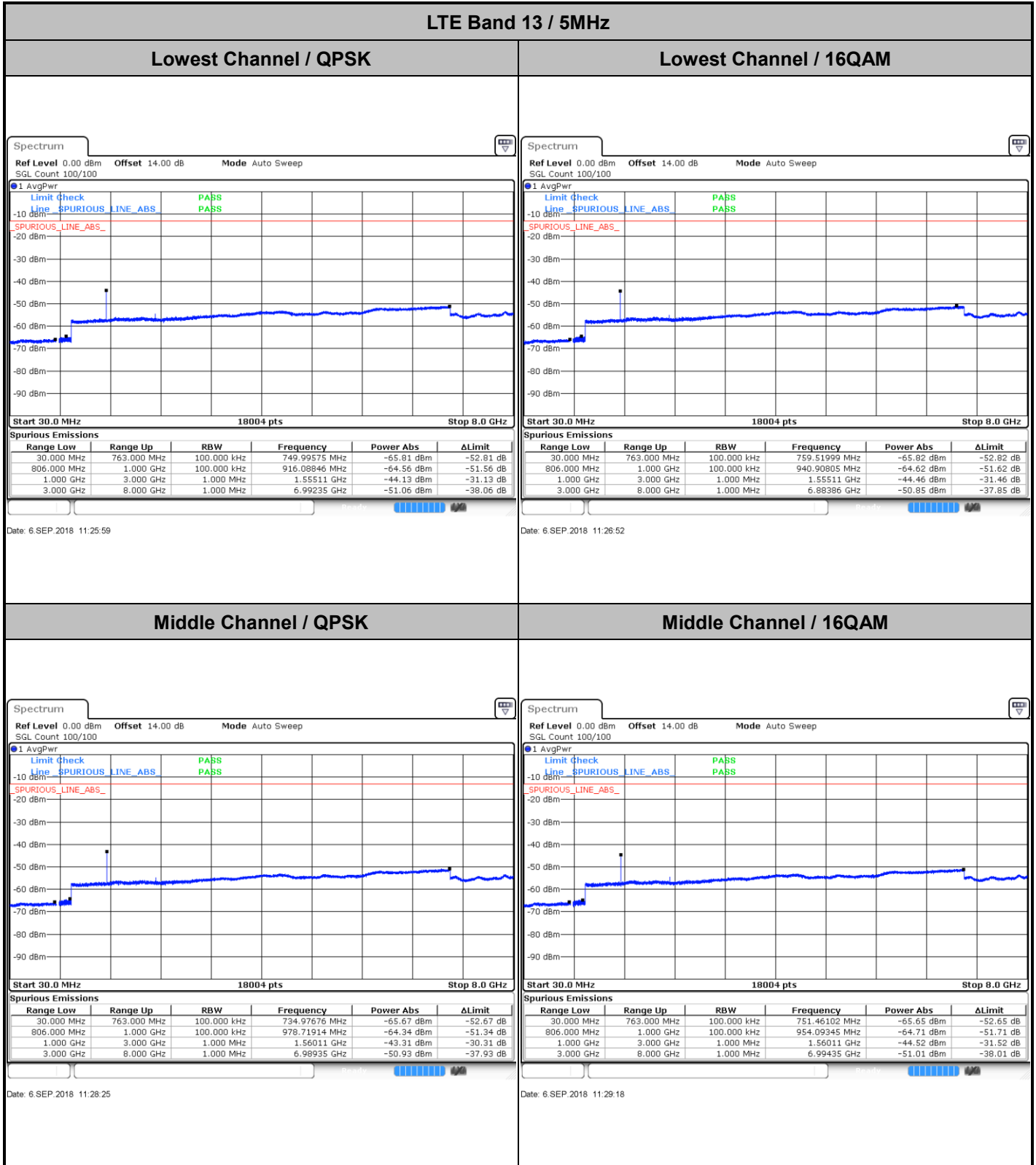



LTE Band 13 / 5MHz

Highest Channel / QPSK

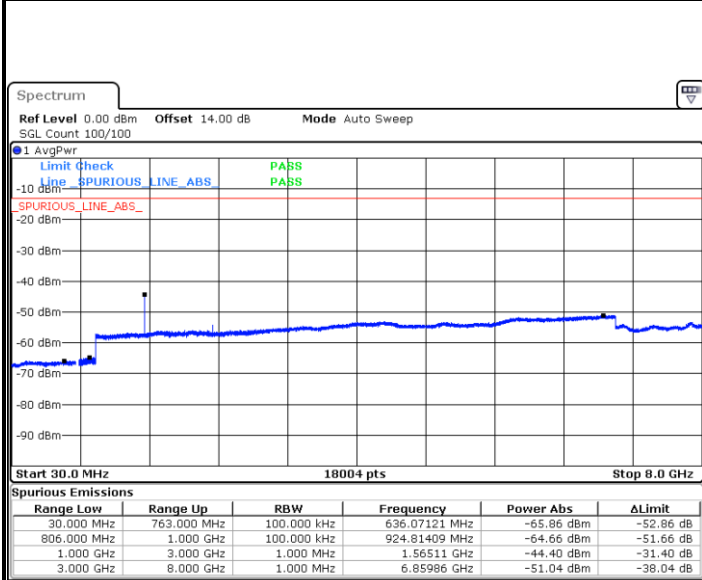

Date: 6 SEP.2018 11:37:22

Highest Channel / 16QAM

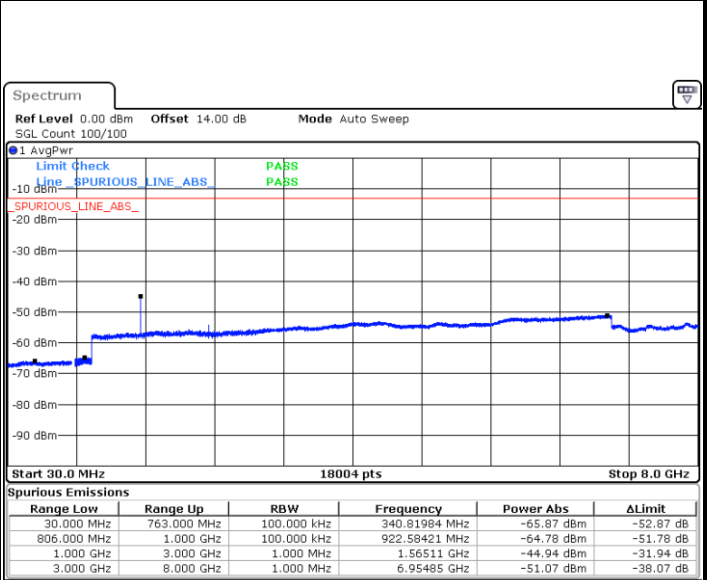

Date: 6 SEP.2018 11:38:15

LTE Band 13 / 10MHz

Middle Channel / QPSK

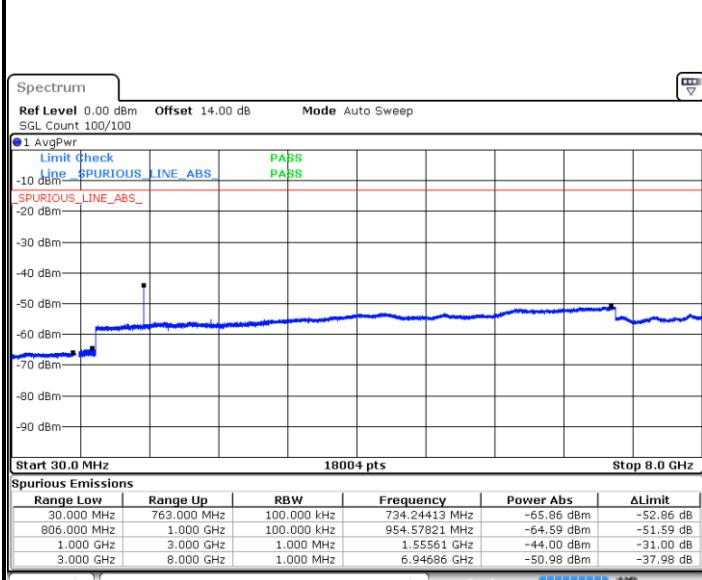

Date: 6 SEP.2018 11:49:35

Middle Channel / 16QAM

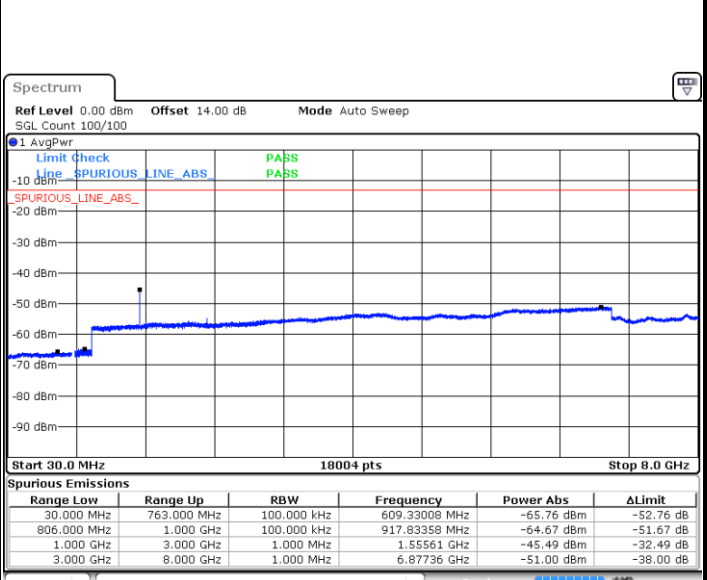

Date: 6 SEP.2018 11:50:28



LTE Band 13 / 5MHz

Lowest Channel / 64QAM

Middle Channel / 64QAM

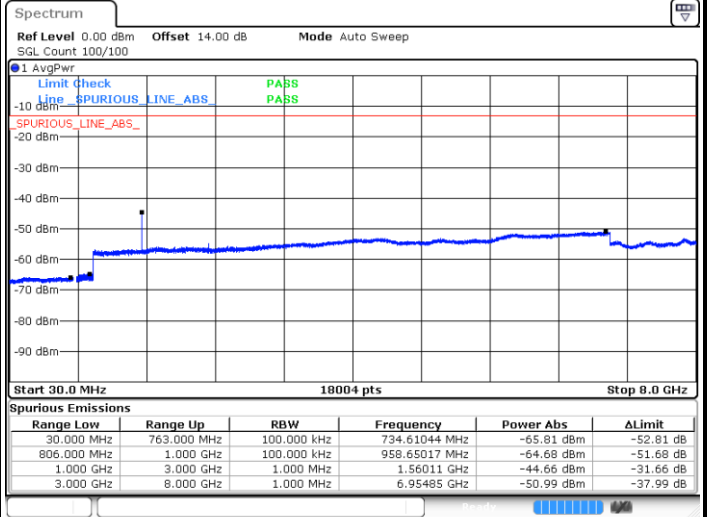
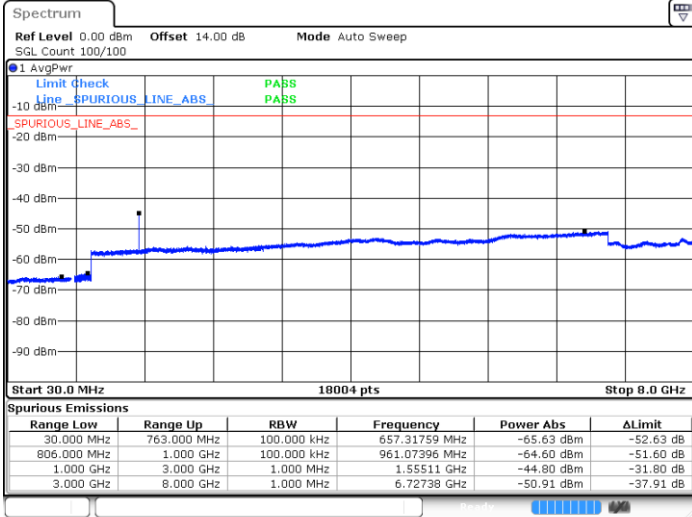

Date: 7.SEP.2018 15:57:26

Date: 7.SEP.2018 15:58:39

Highest Channel / 64QAM

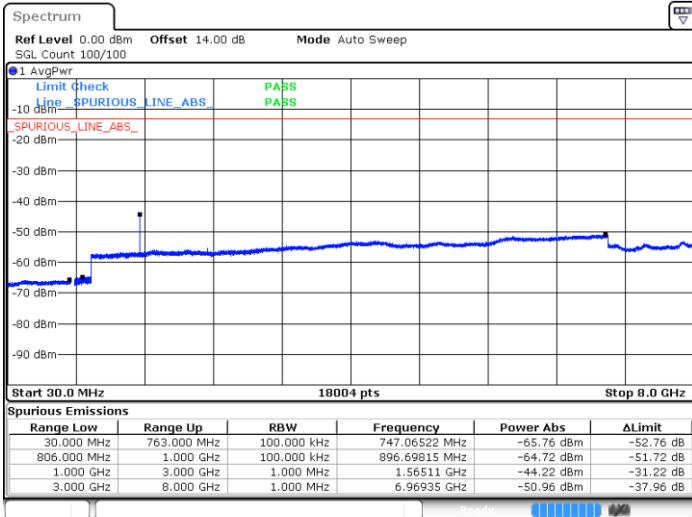

Date: 7.SEP.2018 16:03:08



LTE Band 13 / 10MHz

Middle Channel / 64QAM

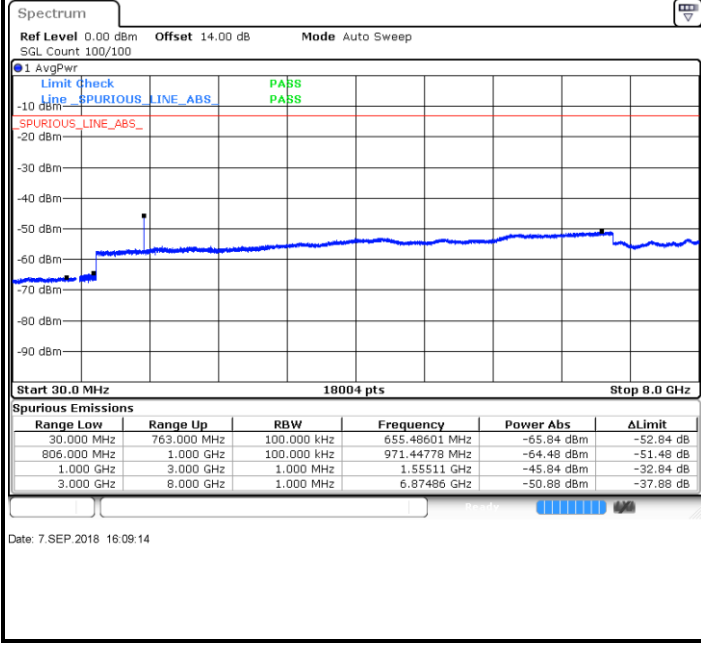



### Frequency Stability

Test Conditions		LTE Band 13 (QPSK) / Middle Channel	Limit
Temperature (°C)	Voltage (Volt)	BW 10MHz	Note 2.
		Deviation (ppm)	Result
50	Normal Voltage	0.0006	PASS
40	Normal Voltage	0.0005	
30	Normal Voltage	0.0003	
20(Ref.)	Normal Voltage	0.0000	
10	Normal Voltage	0.0009	
0	Normal Voltage	0.0001	
-10	Normal Voltage	0.0004	
-20	Normal Voltage	0.0009	
-30	Normal Voltage	0.0000	
20	Maximum Voltage	0.0004	
20	Normal Voltage	0.0005	
20	Battery End Point	0.0004	

**Note:**

1. Normal Voltage =3.8 V. ; Battery End Point (BEP) =3.6 V. ; Maximum Voltage =4.35 V.
2. Note: The frequency fundamental emissions stay within the authorized frequency block.





## Appendix B. Test Results of Radiated Test

### Radiated Spurious Emission

LTE Band 13 / 5MHz / QPSK / RB Size 1 Offset 0									
Channel	Frequency ( MHz )	ERP ( dBm )	Limit ( dBm )	Over Limit ( dB )	SPA Reading (dBm)	S.G. Power ( dBm )	TX Cable loss ( dB )	TX Antenna Gain (dBi)	Polarization (H/V)
Middle	1559.5	-74.43	-40	-34.43	-76.14	-78.96	2.68	9.36	H
	2339.25	-71.50	-13	-58.50	-77.56	-77.50	2.36	10.51	H
	3119	-70.71	-13	-57.71	-78.71	-76.59	4.49	12.52	H
	1559.5	-73.88	-40	-33.88	-75.72	-78.41	2.68	9.36	V
	2339.25	-72.09	-13	-59.09	-78.04	-78.09	2.36	10.51	V
	3119	-70.47	-13	-57.47	-78.50	-76.35	4.49	12.52	V

Remark: Spurious emissions within 30-1000MHz were found more than 20dB below limit line.

LTE Band 13 / 10MHz / QPSK / RB Size 1 Offset 0									
Channel	Frequency ( MHz )	ERP ( dBm )	Limit ( dBm )	Over Limit ( dB )	SPA Reading (dBm)	S.G. Power ( dBm )	TX Cable loss ( dB )	TX Antenna Gain (dBi)	Polarization (H/V)
Middle	1559.5	-64.36	-40	-24.36	-73.59	-68.89	2.68	9.36	H
	2339.25	-60.87	-13	-47.87	-74.78	-66.87	2.36	10.51	H
	3119	-60.73	-13	-47.73	-76.29	-66.61	4.49	12.52	H
	1559.5	-64.82	-40	-24.82	-73.56	-69.35	2.68	9.36	V
	2339.25	-61.93	-13	-48.93	-75.59	-67.93	2.36	10.51	V
	3119	-60.88	-13	-47.88	-76.09	-66.76	4.49	12.52	V

Remark: Spurious emissions within 30-1000MHz were found more than 20dB below limit line.

LTE Band 41 / 10MHz / QPSK / RB Size 1 Offset 0									
Channel	Frequency ( MHz )	EIRP ( dBm )	Limit ( dBm )	Over Limit ( dB )	SPA Reading (dBm)	S.G. Power ( dBm )	TX Cable loss ( dB )	TX Antenna Gain (dBi)	Polarization (H/V)
Middle	5177.18	-41.11	-25	-16.11	-62.66	-46.78	7.13	12.80	H
	7765.77	-51.92	-25	-26.92	-77.00	-55.02	8.50	11.60	H
	10354.36	-48.79	-25	-23.79	-78.47	-50.13	10.68	12.02	H
	5177.18	-43.00	-25	-18.00	-63.55	-48.67	7.13	12.80	V
	7765.77	-52.49	-25	-27.49	-77.03	-55.59	8.50	11.60	V
	10354.36	-48.23	-25	-23.23	-78.44	-49.57	10.68	12.02	V

Remark: Spurious emissions within 30-1000MHz were found more than 20dB below limit line



## **Appendix D. Product Equality Declaration**

# Bullitt Group

One Valpy, Valpy Street, Reading, Berkshire, England RG1 1AR, United Kingdom

Tel: +44 118 9580449

**Date: September 27, 2018**

## Product Equality Declaration

We, Bullitt Group, declare on our sole responsibility for the product of Smartphone as below:

The differences between S48c (VzW Sku) and previous model, S48c (Sprint Sku) are as below:

1. L3613&C3637&L3247&C3232&L3232&C3215&C3018&C3001&U3002 Changed from NC to 0201 8.2nH & 0201 4.7pF & 0201 15nH & 0201 39pF & 0201 22nH & 0201 39pF & 0201 33pF & 0201 33pF & FILTER,SAW FOR GPS 1109
2. R3319&L3238&U3213&L3240&R3005&R3001 Changed from 0201 10nH&0201 15nH&Duplexer, Band 13,1814& 0201 15nH &0201 0Ω&0201 0Ω to 0201 5.6nH & NC& Duplexer, Band 13(NB07), 1814&0201 18Nh&NC&NC
3. S48c (VzW Sku) Based on S48c (Sprint Sku), add the following manufacturers and models of 4+64G memory:  
1st\_ Samsung, 2nd\_Hynix

### **Software change:**

In addition, S48c (VzW Sku) vs. S48c (Sprint Sku), the UL CA was cancelled, and the DL CA was changed to the following combination.

CA\_4A-13A, CA\_13A-66A, CA\_2A-13A, CA\_2A-5A, CA\_4A-5A, CA\_5A-66A, CA\_2A-2A, CA\_5B, CA\_5A-5A, CA\_4A-4A

Except listings above, the others are all the same as previous version.

Should you have any questions or comments regarding this matter, please have my best attention.

Sincerely yours,

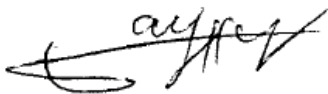

---

Wayne Huang

whuang@bullitt-group.com