



Hearing Aid Compatibility (HAC) T-Coil Test Report

APPLICANT : Bullitt Group
PRODUCT NAME : 4G Mobile Phone
MODEL NAME : S22 Flip
BRAND NAME : CAT
FCC ID : ZL5S22F
STANDARD(S) : FCC 47CFR Part 20(20.19)
ANSI C63.19-2011
RECEIPT DATE : 2021-02-24
TEST DATE : 2021-03-10 to 2021-04-28
ISSUE DATE : 2021-05-27

Edited by: Liang Yumei
Liang Yumei (Rapporteur)

Approved by: Peng Huarui
Peng Huarui (Supervisor)

NOTE: This document is issued by MORLAB, the test report shall not be reproduced except in full without prior written permission of the company. The test results apply only to the particular sample(s) tested and to the specific tests carried out which is available on request for validation and information confirmed at our website.





DIRECTORY

- 1. Attestation of Testing Summary..... 4
- 2. Technical Information 6
 - 2.1. Applicant and Manufacturer Information 6
 - 2.2. Equipment under Test (EUT) Description..... 6
 - 2.3. Photographs of the EUT 8
 - 2.4. Applied Reference Documents 8
- 3. Air Interface and Operating Mode 9
- 4. Measurement standards for T-Coil.....11
 - 4.1. T-Coil Signal Quality Categories.....11
 - 4.2. Frequency Response11
- 5. HAC (T-Coil) Measurement System.....13
 - 5.1. T-Coil Measurement Setup13
 - 5.2. System Validation14
 - 5.3. Base Station Gain Factor.....15
- 6. T-Coil Measurement Procedure.....17
 - 6.1. General Guidance17
 - 6.2. T-Coil Test Flow.....19
 - 6.3. Information of EUT Test Position20
- 7. Test Equipment List21
- 8. T-Coil Testing for CMRS Voice.....22
 - 8.1. Testing Description22
 - 8.2. T-Coil Testing for GSM22
 - 8.3. T-Coil Testing for WCDMA/CDMA22
- 9. T-Coil Testing for CMRS IP Voice24



9.1. T-Coil Testing for VoLTE24
9.2. T-Coil Testing for VoWiFi26
9.3. T-Coil Testing for OTT VoIP Application28
10. Uncertainty Assessment32
Annex A General Information.....33
Annex B Test Setup Photos
Annex C Plots of T-Coil Test Results
Annex D DASY Calibration Certificate

Change History		
Version	Date	Reason for change
1.0	2021-05-27	First edition



1. Attestation of Testing Summary

Air Interface	Frequency Band	T-Rating	Frequency Response	Magnetic Intensity
GSM CMRS Voice	GSM850	T3	Pass	Pass
	GSM1900	T3	Pass	Pass
OTT over EDGE	GSM850	T3	Pass	Pass
	GSM1900	T3	Pass	Pass
UMTS CMRS Voice	Band II	T3	Pass	Pass
	Band IV	T3	Pass	Pass
	Band V	T3	Pass	Pass
OTT over UMTS	Band II	T3	Pass	Pass
	Band IV	T3	Pass	Pass
	Band V	T3	Pass	Pass
CDMA CMRS Voice	BC0	T4	Pass	Pass
	BC1	T4	Pass	Pass
	BC10	T4	Pass	Pass
OTT over CDMA	BC0	T4	Pass	Pass
	BC1	T4	Pass	Pass
	BC10	T4	Pass	Pass
VoLTE	Band 2	T3	Pass	Pass
	Band 4	T3	Pass	Pass
	Band 5	T3	Pass	Pass
	Band 7	T3	Pass	Pass
	Band 12	T3	Pass	Pass
	Band 13	T3	Pass	Pass
	Band 17	T3	Pass	Pass
	Band 25	T3	Pass	Pass
	Band 26	T3	Pass	Pass
	Band 38	T3	Pass	Pass
	Band 40A	T3	Pass	Pass
	Band 40B	T3	Pass	Pass
	Band 41	T3	Pass	Pass
OTT over LTE	Band 2	T3	Pass	Pass
	Band 41	T3	Pass	Pass
VoWiFi	2.4GHz	T3	Pass	Pass



OTT over WiFi	2.4GHz	T4	Pass	Pass
---------------	--------	----	------	------

Note:

1. It is compliance with HAC limits for this device that specified in FCC 47 CFR Part 20(20.19) and ANSI C63.19.
2. When the test result is a critical value, we will use the measurement uncertainty give the judgment result based on the 95% risk level.



2. Technical Information

Note: Provide by applicant.

2.1. Applicant and Manufacturer Information

Applicant:	Bullitt Group
Applicant Address:	One Valpy, Valpy Street, Reading RG1 1AR, United Kingdom
Manufacturer:	Bullitt Group
Manufacturer Address:	One Valpy, Valpy Street, Reading RG1 1AR, United Kingdom

2.2. Equipment under Test (EUT) Description

Product Name:	4G Mobile Phone
IMEI:	351486510002203 351486510002200
Hardware Version:	Q2805_V2.0
Software Version:	LTE_S02113.11_N_S22Flip
Frequency Bands:	GSM 850: 824 MHz ~ 849 MHz GSM 1900: 1850 MHz ~ 1910 MHz WCDMA Band II: 1850 MHz ~ 1910 MHz WCDMA Band IV: 1710 MHz ~ 1755 MHz WCDMA Band V: 824 MHz ~ 849 MHz CDMA BC 0: 824 MHz ~ 849 MHz CDMA BC 1: 1850 MHz ~ 1910 MHz CDMA BC 10: 806 MHz ~ 901 MHz LTE Band 2: 1850 MHz ~ 1910 MHz LTE Band 4: 1710 MHz ~ 1755 MHz LTE Band 5: 824 MHz ~ 849 MHz LTE Band 7: 2500 MHz ~ 2570 MHz LTE Band 12: 699 MHz ~ 716 MHz LTE Band 13: 777 MHz ~ 787 MHz LTE Band 17: 704 MHz ~ 716 MHz LTE Band 25: 1850 MHz ~ 1915 MHz LTE Band 26: 814 MHz ~ 849 MHz LTE Band 38: 2570 MHz ~ 2620 MHz LTE Band 40A: 2305 MHz ~ 2315 MHz LTE Band 40B: 2350 MHz ~ 2360 MHz LTE Band 41: 2496 MHz ~ 2690 MHz



	LTE Band 66: 1710 MHz ~ 1780 MHz LTE Band 71: 663 MHz ~ 698 MHz WLAN 2.4GHz: 2412 MHz ~ 2462 MHz Bluetooth: 2402 MHz ~ 2480 MHz	
Modulation Mode:	GSM/GPRS: GMSK EDGE: 8PSK WCDMA: QPSK, 16QAM CDMA2000 1XRTT: QPSK, 16QAM CDMA2000 1XEV-DO: QPSK, 16QAM LTE: QPSK, 16QAM 802.11b: DSSS 802.11g/n-HT20/40: OFDM BR+EDR: GFSK(1Mbps), $\pi/4$ -DQPSK(2Mbps), 8-DPSK(3Mbps) Bluetooth LE: GFSK(1Mbps)	
Multi-slot Class:	GPRS: Multi-slot Class 33; EDGE: Multi-slot Class 33;	
Operation Class:	Class B	
VoLTE:	Support	
Hotspot Mode:	WWAN/2.4GHz	
Antenna Type:	WWAN: Fixed Internal WLAN: PIFA Antenna Bluetooth: PIFA Antenna	
Battery:	Manufacturer:	Phenix New Energy(Hui Zhou)Co.,Ltd.
	Model Name:	BTE-2000
	Capacity:	2000 mAh
	Rated Voltage:	3.8 V
SIM Cards Description:	GSM+WCDMA+CDMA+LTE	
	Only support single SIM card	



2.3. Photographs of the EUT

Please refer to the External Photos for the Photos of the EUT

2.4. Applied Reference Documents

Leading reference documents for testing:

Identity	Document Title	Method determination Remark
FCC 47 CFR Part 20(20.19)	Hearing aid-compatible mobile handsets.	No deviation
ANSI C63.19-2011	American National Standard Methods of Measurement of Compatibility between Wireless Communications Devices and Hearing Aids	No deviation
KDB 285076 D01v05	HAC Guidance	No deviation
KDB 285076 D02v01r01	T-Coil testing for CMRS IP	No deviation
Note 1: The test item is not applicable. Note 2: Additions to, deviation, or exclusions from the method shall be judged in the "method determination" column of add, deviate or exclude from the specific method shall be explained in the "Remark" of the above table.		



3. Air Interface and Operating Mode

Air Interface	Band	Transport Type	Simultaneous Transmitter	Name of Voice Service	Power Reduction
GSM	GSM850	VO	Wi-Fi & BT	CMRS Voice	No
	GSM1900				No
	EDGE850	VD	WLAN & BT	Google duo	No
	EDGE1900				No
WCDMA (UMTS)	Band II	VO	Wi-Fi & BT	CMRS Voice	No
	Band IV				No
	Band V				No
	HSPA	VD	WLAN & BT	Google duo	No
CDMA	BC0	VO	Wi-Fi & BT	CMRS Voice	No
	BC1				No
	BC10				No
	EVDO	VD	WLAN & BT	Google duo	No
FDD-LTE	Band 2	VD	Wi-Fi & BT	VoLTE & Google duo	No
	Band 4				No
	Band 5				No
	Band 7				No
	Band 12				No
	Band 13				No
	Band 17				No
	Band 25				No
	Band 26				No
	Band 66				No
Band 71	No				
TDD-LTE	Band 38	VD	Wi-Fi & BT	VoLTE & Google duo	No
	Band 40				No
	Band 41				No
Wi-Fi	2450	VD	GSM,UMTS, CDMA, LTE	VoWiFi & Google duo	No
BT	2450	DT	GSM,UMTS, CDMA, LTE	N/A	No
Where: VO=Voice Only DT=Digital Transport only					



VD=CMRS and IP Voice Service over Digital Transport

BT=Bluetooth

* Ref Lev in accordance with 7.4.2.1 of ANSI C63.19-2011 and the July 2012 VoLTE interpretation

** Ref Lev -20 dBm0

*** Ref Lev XYNet established by KDB Inquiry NNNNNN @ -16 dBm0

Note:

- 1) **Air Interface/Band MHz:** List of all air interfaces and bands supported by the handset.
- 2) **Type: For each air interface, indicate the type of voice transport mode:**
 - i. VO = legacy Cellular Voice Service, from Table 7.1 in 7.4.2.1 of ANSI C63.19-2011;
 - ii. DT = Digital Transport only (no voice); and
 - iii. VD = IP Voice Service over Digital Transport.
- 3) **Simultaneous Transmitter:** Indicate any air interface/bands that operate in simultaneous or concurrent service transmission mode.
- 4) **Name of Voice Service:** See Q4 in 285076 D03 HAC FAQ for further clarification.
 - a) Ref Lev in accordance with 7.4.2.1 of ANSI C63.19-2011 and the July 2012 VoLTE interpretation
 - b) ** Ref Lev -20 dBm0
 - c) *** Ref Lev XY Net established by KDB Inquiry NNNNNN @ -16 dBm0
- 5) **LTE-FDD Band 71:** The frequency range of LTE-FDD Band 71 is out of ANSI C63.19-2011, therefore T-Coil for VoLTE of LTE Band 71 is not required.

4. Measurement standards for T-Coil

4.1. T-Coil Signal Quality Categories

This sub clause specifies the signal-to-noise quality requirement for the intended T-Coil signal from a WD. The worst signal to noise of the two T-Coil signal measurements, as determined in Clause 7, shall be used to determine the T-Coil mode category per Table 2.1.

Only the RF immunity of the hearing aid is measured in T-Coil mode. It is assumed that a hearing aid can have no immunity to an interference signal in the audio band, which is the intended reception band for this mode. So, the only criterion that can be measured is the RF immunity in T-Coil mode. The RF measurements made for the T-Coil evaluation are used to assign the category T1 through T4. The limitation is given in Table 1. This establishes the RF environment presented by the WD to a hearing aid.

Category	Telephone parameters WD signal quality [(signal + noise)-to-noise ratio in decibels]
Category T1	0 dB to 10 dB
Category T2	10 dB to 20 dB
Category T3	20 dB to 30 dB
Category T4	>30 dB

Table 2.1 T-Coil signal-to-noise categories

4.2. Frequency Response

This sub clause describes the relationship between the M rating, which is based on the RF emission tests performed in Clause 5, and the T rating, which is based on the T-Coil tests performed in Clause 7.

If the WD achieves an acceptable category rating per ANSI C63.19-2011 section 8.2, as determined by the appropriate regulating authority, it becomes a candidate for the T designation (see ANSI C63.19-2011 section 8.3.4).

The frequency response of the perpendicular component of the magnetic field, measured in 1/3 octave bands, shall follow the response curve specified in this sub-clause, over the frequency range 300 Hz to 3000 Hz.

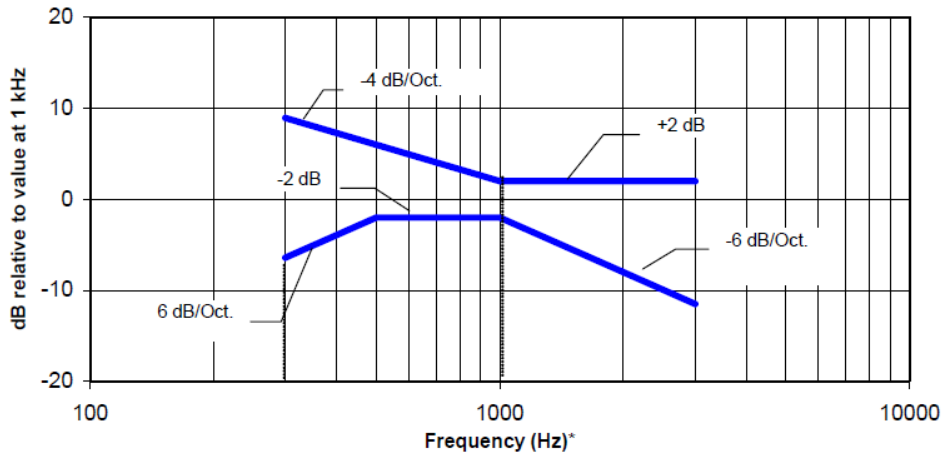

NOTE—The frequency response is between 300 Hz and 3000 Hz.

Fig 2.1 Magnetic field frequency response for WDs with field strength ≤ -15 dB(A/m) at 1 kHz

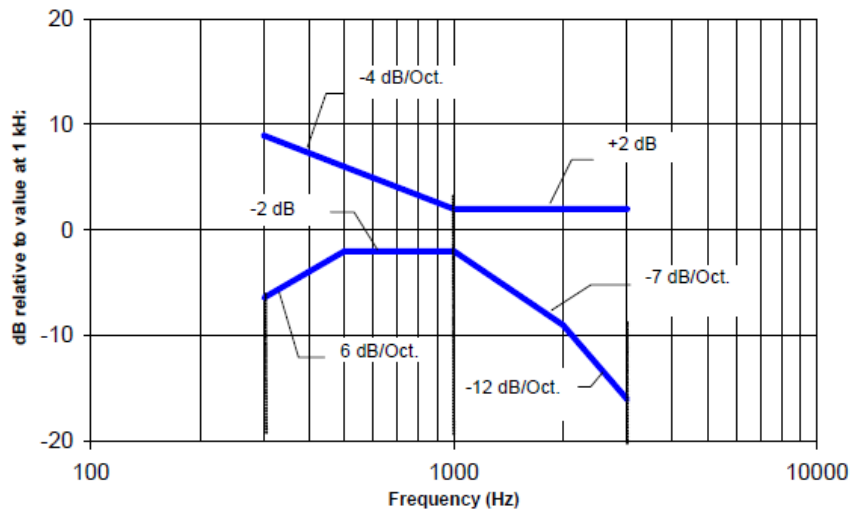

NOTE—The frequency response is between 300 Hz and 3000 Hz.

Fig 2.2 Magnetic field frequency response for WDs with a field that exceeds -15 dB(A/m) at 1 kHz

5. HAC (T-Coil) Measurement System

5.1. T-Coil Measurement Setup

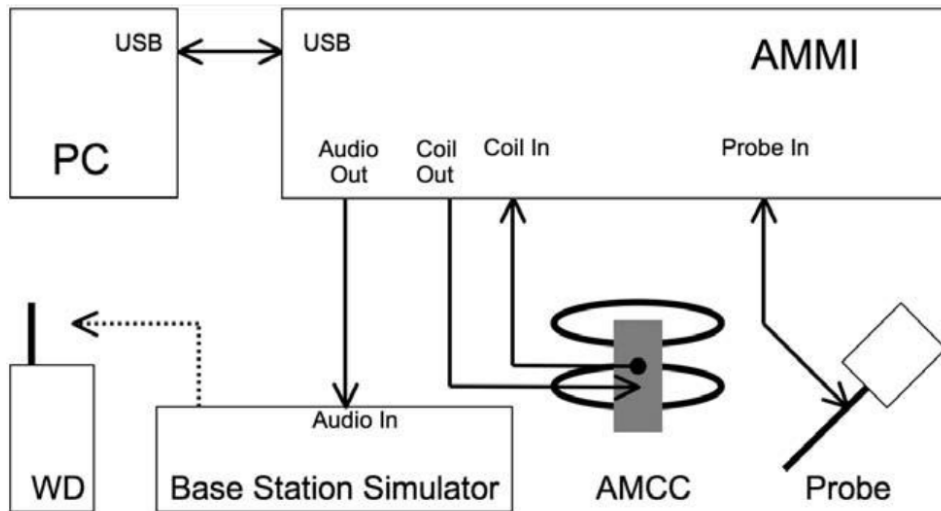

Fig 5.1 SPEAG T-Coil System Configurations

Note:

- 1、 Per C63 & KDB 285076 D02v03, define the all applicable input audio level:
 - 1) GSM input level: -16dBm0
 - 2) UMTS input level: -16dBm0
 - 3) VoLTE input level: -16dBm0
 - 4) VoWiFi input level: -20dBm0
 - 5) OTT Voip input level: -20dBm0
- 2、 A communication base station CMU200 is used for testing GSM / UMTS / CDMA, and it's "Decode Cal" and "Codec Cal" with audio option B52 and B85 to set the correct audio input level.
- 3、 CMU200 is able to output 1KHz audio signal equivalent to 3.14dBm0 at "Decode Cal", the signal reference is used to adjust the AMMI gain setting to reach -16dBm0 for GSM/UMTS and -18dBm0 for CDMA.
- 4、 The callbox of CMW500 is used for VoLTE over IMS and VoWiFi over IMS T-Coil measurement, the data application unit of the CMW500 was used to simulate the IP multimedia subsystem server. And the CMW500 can be manually configured to ensure and control the speech input level result is -16dBm0 for VoLTE and -20dBm0 for VoWiFi when the device during the IMS connection.
- 5、 The OTT VOIP call is tested on the data application unit of CMW500 connection to the internet.

5.2. System Validation

For correct and calibrated measurement of the voltages and ABM filed, DASY will perform a calibration job follows below:

1. In phase 1, the audio output is switched off, and a 200 mW symmetric rectangular signal of 1 kHz is connected directly to both channels of the sampling unit(Coil in, Probe in).
2. In phase 2, the audio output is off, and a 20 mW symmetric 100 Hz signal is internally connected. The signals during phases 1 and 2 are available at the output on the rear panel of the AMMI. However, the output must not be loaded, in order to avoid influencing the calibration, an RMS voltmeter would indicate 100mWRMS, during the second phase after the first two phases, the two input channels are both calibrated for absolute ants of voltages. The resulting factors are displayed above the multi-meter window.
3. After phases 1 and 2, the input channels are calibrated to measure exact voltages. This is required to use the inputs for measuring voltages with their peak and RMS value.
4. In phase 3, a mult-sine signal covering each third-octave band from 50 Hz to 10 kHz is generated and applied to both audio outputs. The probe should be positioned in the center of the AMCC and aligned in the z-direction, the filed orientation of the AMCC. The "Coil In" channel is measuring the voltage over the AMCC internal shunt, which is proportional to the magnetic filed in the AMCC. At the same time, the "Probe In" channel samples the amplified signal picked up by the probe coil and provides a numerical integrator. The ratio of two voltages in each third-octave filter leads to the spectral representation over the frequency band of interest. The coil signal is scaled in dBV, and the probe signal is first integrated and normalized to show dB A/m. The ratio probe-to-coil at the frequency of 1KHz is the sensitivity which will be used in the consecutive T-coil jobs,.
5. The ABM validation during testing as below.

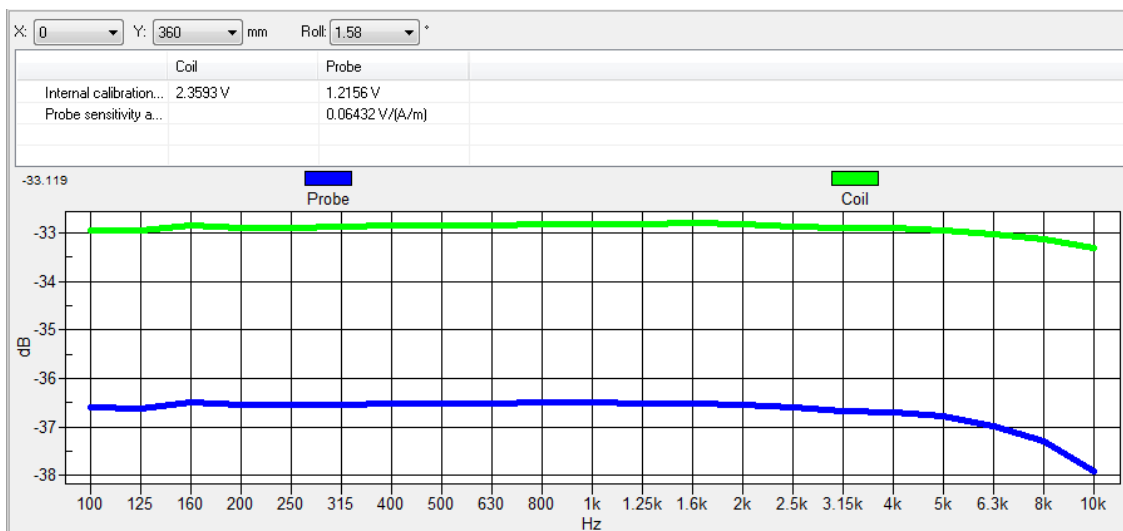



5.3. Base Station Gain Factor

1. The Required gain factor for the specific signal shall typically be multiplied by this factor to achieve approx. the same level as for the 1kHz sine signal.
2. The calculation formula as below showing how to determine the input level for air interface for this device.

The predefined signal types have the following differences / factors compared to the 1kHz sine signal:

Signal [file name]	Duration [s]	Peak-to-RMS [dB]	RMS [dB]	Required gain factor (*)	Gain setting
1kHz sine	---	3.0	0.0	1.00	
48k_1.025kHz_10s.wav	10	3.0	0.0	1.00	
48k_1kHz_3.15kHz_10s.wav	10	6.0	-3.0	1.42	
48k_315Hz_1kHz_10s.wav	10	6.0	-2.9	1.40	
48k_csek_8k_441_white_10s.wav	10	13.8	-10.5	3.34	
48k_multisine_50-5000_10s.wav	10	11.1	-7.9	2.49	
48k_voice_1kHz_1s.wav	1	16.2	-12.7	4.33	
48k_voice_300-3000_2s.wav	2	21.6	-18.6	8.48	

(*) The gain for the specific signal shall typically be multiplied by this factor to achieve approx. the same level as for the 1kHz sine signal.

Insert the gain applicable for your setup in the last column of the table.

CMU200 for GSM WCDMA

<Input level determination >

Gain Value (linear)	20* log(gain) dB	AMCC Coil in (dBv RMS)	Level dBm0
-	-	-2.44	3.14
10	20	-20.96	-15.38
9.31	19.38	-21.58	-16

<Base station gain factor calculation>

Signal Type	Duration (s)	Peak to RMS (dB)	RMS (dB)	Gain Factor	Gain Setting
1kHz sine	-	3	0	1	8.17
48k_voice_1kHz	1	16.2	-12.7	4.33	40.32
48k_voice_300-3000	2	21.6	-18.6	8.48	78.96



CMU200 for CDMA

<Input level determination >

Gain Value (linear)	20* log(gain) dB	AMCC Coil in (dBV RMS)	Level dBm0
		-2.44	3.14
10	20	-20.96	-15.38
7.40	17.38	-23.58	-18

<Base station gain factor calculation>

Signal Type	Duration (s)	Peak to RMS (dB)	RMS (dB)	Gain Factor	Gain Setting
1kHz sine	-	3	0	1	8.17
48k_voice_1kHz	1	16.2	-12.7	4.33	32.02
48k_voice_300-3000	2	21.6	-18.6	8.48	62.72

CMW500 for VoLTE

<Input level determination >

Gain Value	dBm	Full scal Voltage	dB	AMMI audio out (dBV) (RMS)	AMCC Coil Out (dBV) (RMS)
N/A	3.14	1.5	N/A	0.51	N/A
100	5.61	N/A	40	2.98	3.13
8.31	-16	N/A	18.39	N/A	-18.48

<Base station gain factor calculation>

Signal Type	Duration (s)	Peak to RMS (dB)	RMS (dB)	Gain Factor	Gain Setting
48k_voice_1kHz	1	16.2	-12.7	4.33	35.98
48k_voice_300-3000	2	21.6	-18.6	8.48	70.46



6. T-Coil Measurement Procedure

6.1. General Guidance

T-Coil measurement follows ANSI C63.19-2011, Section 7.4

This section describes the procedures used to measure the ABM (T-Coil) performance of the WD. In addition to measuring the absolute signal levels, the A-weighted magnitude of the unintended signal shall also be determined. To assure that the required signal quality is measured, the measurement of the intended signal and the measurement of the unintended signal must be made at the same location for each measurement position. In addition, the RF field strength at each measurement location must be at or below that required for the assigned category.

Measurements shall not include undesired properties from the WD's RF field; therefore, use of a coaxial connection to a base station simulator or non-radiating load, there might still be RF leakage from the WD, which can interfere with the desired measurement. Pre-measurement checks should be made to avoid this possibility. All measurements shall be performed with the WD operating on battery power with an appropriate normal speech audio signal input level given in ANSI C63.19-2011 Table 7.1. If the device display can be turned off during a phone call, then that may be done during the measurement as well.

Measurement shall be performed at two locations specified in ANSI C63.19-2011 A.3, with the correct probe orientation for a particular location, in a multistage sequence by first measuring the field intensity of the desired T-Coil signal the same location as the desired ABM or T-Coil signal (ABM1), and the ratio of desired to undesired magnetic components (ABM2) must be measured at the same location as the desired ABM or T-Coil signal (ABM1), and the ratio of desired to undesired ABM signals must be calculated. For the perpendicular field location, only the ABM1 frequency response shall be determined in a third measurement stage.

The following steps summarize the basic test flow for determining ABM1 and ABM2. These steps assume that a sine wave or narrowband 1/3 octave signal can be used for the measurement of ABM1.

- 1) A validation of the test setup and instrumentation may be performed using a TMFS or Helmholtz coil. Measure the emissions and confirm that they are within the specified tolerance.
- 2) Position the WD in the test setup and connect the WD RF connector to a base station simulator or a non-radiating load. Confirm that equipment that requires calibration has been calibrated, and that the noise level meets the requirements given in ANSI C63.19-2011 clause 7.3.1.
- 3) The drive level to the WD is set such that the reference input level specified in ANSI C63.19-2011 Table 7.1 is input to the base station simulator (or manufacturer's test mode equivalent) in 1 kHz, 1/3 octave band. This drive level shall be used for the T-Coil signal test (ABM1) at $f = 1$ kHz. Either a sine wave at 1025 Hz or a voice-like signal, band-limited to the 1 kHz 1/3 octave, as defined in ANSI C63.19-2011 clause 7.4.2, shall be used for the reference audio signal. If interference is found at 1025 Hz an alternative nearby reference audio signal frequency may be



used. The same drive level shall be used for the ABM1 frequency response measurements at each 1/3 octave band center frequency. The WD volume control may be set at any level up to maximum, provided that a signal at any frequency at maximum modulation would not result in clipping or signal overload.

- 4) Determine the magnetic measurement locations for the WD device (A.3), if not already specified by the manufacturer, as described in ANSI C63.19-2011 clause 7.4.4.1.1 and 7.4.4.2.
- 5) At each measurement location, measure and record the desired T-Coil magnetic signals (ABM1 at f_i) as described in ANSI C63.19-2011 clause 7.4.4.2 in each individual ISO 266-1975 R10 standard 1/3 octave band. The desired audio band input frequency (f_i) shall be centered in each 1/3 octave band maintaining the same drive level as determined in item c) and the reading taken for that band. Equivalent methods of determining the frequency response may also be employed, such as fast Fourier transform (FFT) analysis using noise excitation or input-output comparison using simulated speech. The full-band integrated probe output, as specified in D.9, may be used, as long as the appropriate calibration curve is applied to the measured result, so as to yield an accurate measurement of the field magnitude. (The resulting measurement shall be an accurate measurement in dB A/m.)
- 6) All Measurements of the desired signal shall be shown to be of the desired signal and not of an undesired signal. This may be shown by turning the desired signal ON and OFF with the probe measuring the same location. If the scanning method is used the scans shall show that all measurement points selected for the ABM1 measurement meet the ambient and test system noise criteria in ANSI C63.19-2011 clause 7.3.1.
- 7) At the measurement location for each orientation, measure and record the undesired broadband audio magnetic signal (ABM2) as specified in ANSI C63.19-2011 clause 7.4.4.4 with no audio signal applied (or digital zero applied, if appropriate) using A-weighting and the half-band integrator. Calculate the ratio of the desired to undesired signal strength (i.e., signal quality). Obtain the data from the postprocessor, SEMCAD, and determine the category that properly classifies the signal quality based on ANSI C63.19-2011 Table 8.5.

6.2. T-Coil Test Flow

This section follows ANSI C63.19-2011 section 7.4.1:

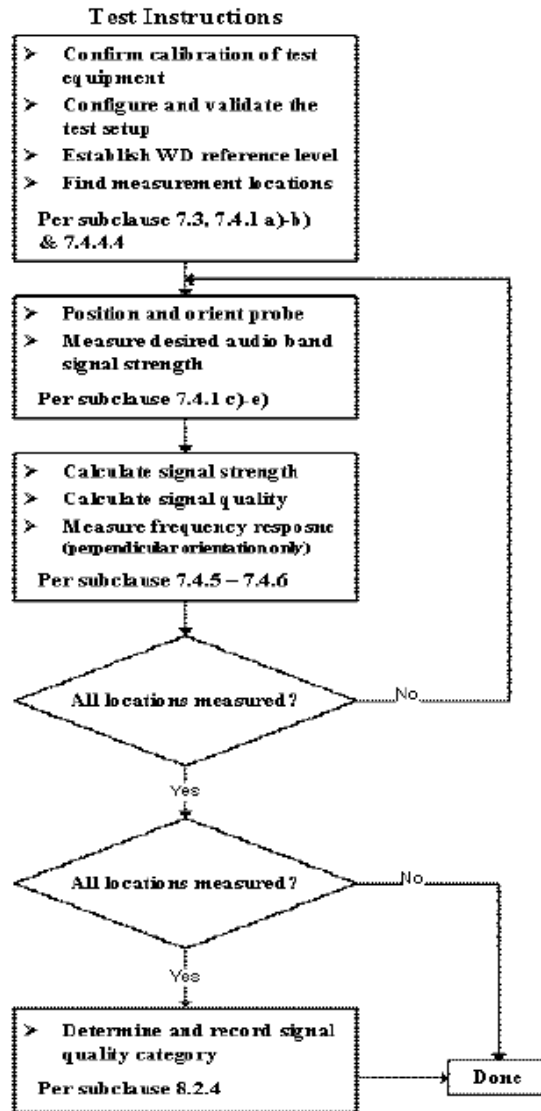

Fig 6.1 WD T-Coil signal test flowchart

6.3. Information of EUT Test Position

Fig2.2 illustrates the measurement locations and reference plane to be used for the T-Coil measurements. And measurement setup follows:

- 1、 The scan area is 5cm*5cm.
- 2、 The area is centered on the audio frequency output transducer of the EUT.
- 3、 The area is in a reference plane, which is defined as the planar area that contains the highest point in the area of the phone that normally rests against the user’s ear. It’s parallel to the centerline of the receiver area of the phone and is defined by the points of the receiver-end of the EUT handset, which in normal handset use, rests against the ear.
- 4、 The measurement plane is parallel to, and 10mm in front of the reference plane.

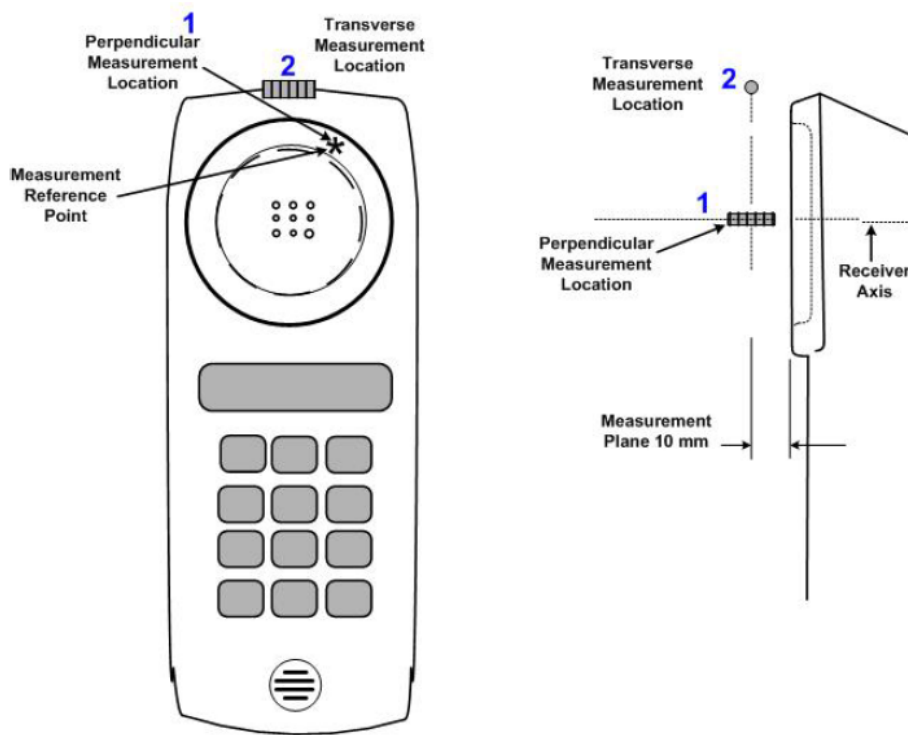

Fig 6.2 A typical EUT reference and plane for T-Coil measurement



7. Test Equipment List

Manufacturer	Name of Equipment	Type/Model	Serial Number	Calibration	
				Last Cal.	Due Date
SPEAG	Audio Magnetic 1D Field Probe	AM1DV2	3128	2020.06.18	2021.06.17
SPEAG	Audio Magnetic Calibration Coil	AMCC	1044	NCR	NCR
SPEAG	Audio Measuring Instrument	AMMI	1032	NCR	NCR
SPEAG	Audio Holder	N/A	1094	NCR	NCR
SPEAG	Data Acquisition Electronics	DAE4	480	2020.06.03	2021.06.02
R&S	Base Station	CMU200	107082	2020-10-19	2021.10.18
R&S	Network Emulator	CMW500	165755	2020.10.28	2021.10.27



8. T-Coil Testing for CMRS Voice

8.1. Testing Description

1. The middle channel of each frequency band is used for T-Coil testing according ANSI C63.19 2011.
2. For VoLTE radio configuration investigation is choose either one codec and an investigation was performed on all frequency band, data rates and modulations and RB configuration to determine the radio configuration to be used for testing, the following tests results which the worst case configuration would be remarked to be used for the testing for the handset.
3. According to KDB 285076, Reporting results involves a two-step process: (1) Codec Investigation to determine the worst-case codec for each voice service, and (2) Air Interface Investigation. Using the worst-case codec for a voice service, a range of channels and bands shall be tested.

8.2. T-Coil Testing for GSM

➤ GSM Test Results

Plot No.	Air Interface	Mode	Channel	Probe Position	ABM1 dB (A/m)	ABM2 dB (A/m)	Signal Quality (dB)	T Rating	Frequency Response
1	GSM850	GSM Voice	189	Axial (Z)	-12.32	-42.60	30.28	T4	PASS
				Transversal (Y)	-5.78	-30.74	24.96	T3	
2	GSM1900	GSM Voice	661	Axial (Z)	-12.91	-44.88	31.97	T4	PASS
				Transversal (Y)	-5.66	-30.59	24.93	T3	

8.3. T-Coil Testing for WCDMA/CDMA

<Codec Investigation>

Air Interface	Modulation	Channel	Probe Position	ABM1 dB (A/m)	ABM2 dB (A/m)	Signal Quality (dB)
WCDMA Band II	AMR 12.2Kbps	9400	Axial (Z)	-12.89	-49.71	36.82
	AMR 7.95Kbps	9400	Axial (Z)	-11.76	-49.28	37.52
	AMR 4.75Kbps	9400	Axial (Z)	-10.09	-47.74	37.65

Note: Highlight part of test mode.



➤ **WCDMA Test Results**

Plot No.	Air Interface	Channel	Probe Position	ABM1 dB (A/m)	ABM2 dB (A/m)	Signal Quality (dB)	T Rating	Frequency Response
3	WCDMA Band II	9400	Axial (Z)	-12.89	-49.71	36.82	T4	Pass
			Transversal (Y)	-2.39	-28.29	25.90	T3	
4	WCDMA Band IV	1413	Axial (Z)	-12.51	-47.78	35.27	T4	Pass
			Transversal (Y)	-2.48	-28.31	25.83	T3	
5	WCDMA Band V	4182	Axial (Z)	-12.52	-46.70	34.18	T4	Pass
			Transversal (Y)	-2.50	-28.37	25.87	T3	

➤ **CDMA Test Results**

<Air Interface Investigation>

Air Interface	Modulation	Channel	Probe Position	ABM1 dB (A/m)	ABM2 dB (A/m)	Signal Quality (dB)
CDMA BC0	RC1 SO1	384	Axial (Z)	-12.80	-48.05	35.25
	RC1 SO3	384	Axial (Z)	-13.60	-47.82	34.22
	RC1 SO68	384	Axial (Z)	-13.03	-48.05	35.02

Note:

The highlight part of RC1 SO3 is the worst air interface and would be used to testing.

Plot No.	Air Interface	Channel	Probe Position	ABM1 dB (A/m)	ABM2 dB (A/m)	Signal Quality (dB)	T Rating	Frequency Response
8	WCDMA BC0	384	Axial (Z)	-13.60	-47.82	34.22	T4	Pass
			Transversal (Y)	-2.34	-51.24	48.90	T4	
9	WCDMA BC1	600	Axial (Z)	9.80	-54.87	64.67	T4	Pass
			Transversal (Y)	-1.53	-50.13	48.60	T4	
10	WCDMA BC10	580	Axial (Z)	-12.34	-47.37	35.03	T4	Pass
			Transversal (Y)	-5.78	-49.97	44.19	T4	



9. T-Coil Testing for CMRS IP Voice

9.1. T-Coil Testing for VoLTE

➤ General Test Guidance

1. The middle channel of each frequency band is used for T-Coil testing to determine the worst HAC T-Coil rating according ANSI C63.19 2011.
2. For VoLTE radio configuration investigation is choose either one codec and an investigation was performed on all frequency band, data rates and modulations and RB configuration to determine the radio configuration to be used for testing, the following tests results which the worst case configuration would be remarked to be used for the testing for the handset.
3. According to KDB 285076, reporting results involves a two-step process:
 - a. Codec Investigation to determine the worst-case codec for each voice service.
 - b. Air Interface Investigation: Using the worst-case codec for a voice service, a range of channels and bands shall be tested.

➤ Radio Configuration Investigation

Air Interface	Modulation	Channel	Probe Position	ABM1 dB (A/m)	ABM2 dB (A/m)	Signal Quality (dB)
LTE Band 2	QPSK 1RB0 20MHz	18900	Axial (Z)	-12.62	-46.83	34.21
	16QAM 1RB0 20MHz		Axial (Z)	-12.37	-47.14	34.77
	64QAM 1RB0 20MHz		Axial (Z)	-12.09	-47.48	35.39

Note: Highlight part of test mode.

<Air interface Investigation>

Air Interface	Modulation	Channel	Probe Position	ABM1 dB (A/m)	ABM2 dB (A/m)	Signal Quality (dB)
LTE Band 2	AMR 12.2Kbps	18900	Axial (Z)	-12.62	-46.83	34.21
	AMR 7.95Kbps	18900	Axial (Z)	-12.16	-47.05	34.89
	AMR 4.75Kbps	18900	Axial (Z)	-11.79	-46.96	35.17



<EVS Codec Investigation>

Code	NB AMR(Kbps)		WB AMR(Kbps)		EVS SWB(Kbps)		EVS NB(Kbps)		EVS WB(Kbps)	
Channel 18900	4.75	6.60	12.2	23.85	9.6	128	5.9	24.4	5.9	128
ABM 1(dBA/m)	-1.0	2.1	2.44	2.88	2.28	3.01	1.1	4.56	2.77	5.92
ABM 2(dBA/m)	-38.97	-33.99	-36.12	-34.01	-33.60	-32.68	-32.03	-32.46	-33.33	-30.84
SNR(dB)	37.97	36.09	33.56	36.89	35.88	35.69	38.13	37.02	36.1	36.76
Fre. Response	Pass	Pass	Pass	Pass	Pass	Pass	Pass	Pass	Pass	Pass

Note: The worst codec for WB AMR 12.2Kbps will be used to air interface investigation.

➤ VoLTE Test Results

Plot No.	Air Interface	Mode	Channel	Probe Position	ABM1 dB (A/m)	ABM2 dB (A/m)	Signal Quality (dB)	T Rating	Frequency Response
01	LTE Band 2	1RB0 20MHz	18900	Axial (Z)	-12.62	-46.83	34.21	T4	Pass
				Transversal (Y)	-4.35	-29.60	25.25	T3	
02	LTE Band 4	1RB0 20MHz	20175	Axial (Z)	-11.79	-46.34	34.55	T4	Pass
				Transversal (Y)	-11.92	-40.02	28.10	T3	
03	LTE Band 5	1RB0 10MHz	20525	Axial (Z)	-12.63	-47.87	35.24	T4	Pass
				Transversal (Y)	-2.04	-28.42	26.38	T3	
04	LTE Band 7	1RB0 20MHz	21100	Axial (Z)	-13.13	-47.69	34.56	T4	Pass
				Transversal (Y)	-4.93	-31.18	26.25	T3	
05	LTE Band 12	1RB0 10MHz	23095	Axial (Z)	-12.85	-49.27	36.42	T4	Pass
				Transversal (Y)	-2.15	-28.49	26.34	T3	
06	LTE Band 13	1RB0 10MHz	23230	Axial (Z)	-12.95	-50.59	37.64	T4	Pass
				Transversal (Y)	-3.52	-29.78	26.26	T3	
07	LTE Band 17	1RB0 10MHz	23790	Axial (Z)	-12.93	-50.75	37.82	T4	Pass
				Transversal (Y)	-2.04	-28.43	26.39	T3	
08	LTE Band 25	1RB0 20MHz	26365	Axial (Z)	-12.67	-48.07	35.40	T4	Pass
				Transversal (Y)	-7.54	-33.85	26.31	T3	
09	LTE Band 26	1RB0 15MHz	26865	Axial (Z)	-12.98	-49.81	36.83	T4	Pass
				Transversal (Y)	-2.07	-28.35	26.28	T3	
10	LTE Band 38	1RB0 20MHz	38000	Axial (Z)	-16.74	-46.91	30.17	T4	Pass
				Transversal (Y)	-4.84	-31.18	26.34	T3	
11	LTE Band40A	1RB0 10MHz	38750	Axial (Z)	-17.06	-47.20	30.14	T4	Pass
				Transversal (Y)	-1.88	-28.26	26.38	T3	



12	LTE Band 40B	1RB0 10MHz	39200	Axial (Z)	-17.11	-46.86	29.75	T3	Pass
				Transversal (Y)	-5.16	-31.54	26.38	T3	
13	LTE Band 41	1RB0 20MHz	40620	Axial (Z)	-17.66	-45.33	27.67	T3	Pass
				Transversal (Y)	-2.84	-29.31	26.47	T3	
14	LTE Band 66	1RB0 20MHz	132322	Axial (Z)	1.67	-23.43	25.10	T3	Pass
				Transversal (Y)	-7.66	-32.77	25.11	T3	

9.2. T-Coil Testing for VoWiFi

➤ General Test Guidance

1. The middle channel of each frequency band is used for T-Coil testing according ANSI C63.19 2011.
2. According to KDB 285076, recording the results involves follow process:
 - I. Codec Investigation to determine the worst-case codec for each voice service.
 - II. Air Interface Investigation: Using the worst-case codec for a voice service, a range of channels and bands shall be tested.
3. For VoWiFi, the lowest data rate of each wireless system for 2.4G WLAN will be used to testing according to the conducted power list.
4. The T-Coil measurement procedure given of VoWiFi should be applied:
 - Step 1: Comparing the output power of the WLAN systems, the maximum output power including tune-up tolerance for 2.4GHz WLAN was selected to perform codec investigation of Z axial, recording the results of ABM1, ABM2, SNR and frequency response at the same time.
 - Step 2: Per step 1, selecting the worst codec perform air interface investigation of all of the WLAN modes including to 2.4GHz and 5GHz WLAN.
 - Step 3: Per step 2, selecting the worst SNR of 2.4G WLAN and 5GHz WLAN to perform the T-Coil testing of Z axial and Y transversal and the test results would be recorded in the report.

➤ Air Interface Investigation

Bands	Wireless System	Data Rate (Mbps)	Channel	ABM 1 (dBA/m)	ABM 2 (dBA/m)	SNR(dB)
WLAN 2.4GHz	802.11b	1	6	-4.03	-51.86	47.83
	802.11g	6	6	-8.34	-52.81	44.47
	802.11n-HT20	MCS 0	6	-8.33	-52.07	43.74
	802.11n-HT40	MCS 0	6	-11.82	-40.44	28.62

➤ Test Results



Air Interface	Mode	Channel	Probe Position	ABM1 dB (A/m)	ABM2 dB (A/m)	SNR (dB)	T Rating	Frequency Response
WLAN 2.4GHz	802.11b	6	Axial (Z)	-4.03	-51.86	47.83	T4	Pass
			Transversal (Y)	-10.91	-47.73	36.82	T4	
	802.11g	6	Axial (Z)	-8.34	-52.81	44.47	T4	Pass
			Transversal (Y)	-16.82	-49.44	32.62	T4	
	802.11n-HT20	6	Axial (Z)	-8.33	-52.07	43.74	T4	Pass
			Transversal (Y)	-15.81	-49.67	33.86	T4	
	802.11n-HT40	6	Axial (Z)	-11.82	-40.44	28.62	T3	Pass
			Transversal (Y)	-13.74	-41.67	27.93	T3	

9.3. T-Coil Testing for OTT VoIP Application

➤ T-Coil Measurement Setup for OTT VoIP

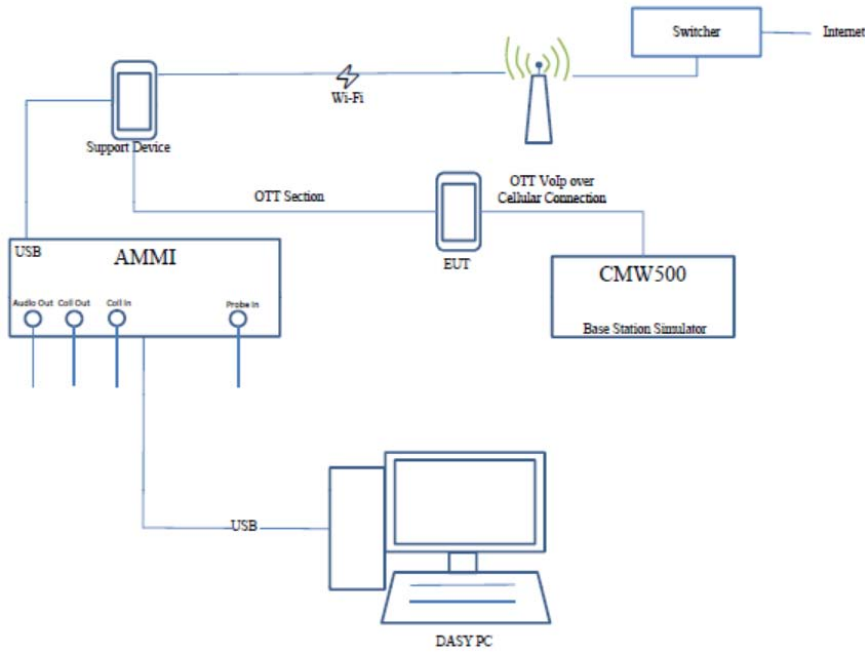

Fig 9.1 Test Setup Configuration for OTT Calling

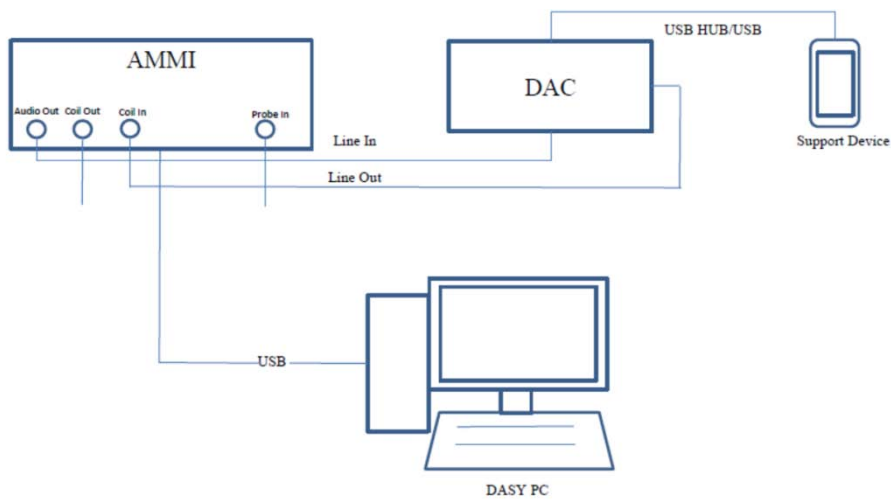

Fig 9.2 Test Setup for Audio Analysis



➤ **General Test Guidance**

1. The middle channel of each frequency band is used for T-Coil testing to determine the worst HAC T-Coil rating according ANSI C63.19 2011.
2. For VoLTE radio configuration investigation is selected either one codec and an investigation was performed on all frequency band, data rates and modulations and RB configuration to determine the radio configuration to be used for testing, the following tests results which the worst case configuration would be remarked to be used for the testing for the handset.
3. According to KDB 285076, recording the results involves follow process:
 - I. Codec Investigation to determine the worst-case codec for each voice service.
 - II. Air Interface Investigation: Using the worst-case codec for a voice service, a range of channels and bands shall be tested.
4. For google duo, the 6Kbps, 40Kbps and 75Kbps bit rate of the OPUS auto codec will be used to codec investigating and the worst case used to T-Coil testing.
5. The worst configuration and frequency band of air interface according to VoLTE and VoWiFi test results of air interface investigation for both the OTT service and CMRS IP service are established over the internet protocol for the voice service, and the services use the identical RF air interface for the LTE and WiFi.
 - I. The worst configuration of FDD-LTE frequency band: LTE Band 2/20MHz/QPSK/1RB 0Offset.
 - II. The worst configuration of TDD-LTE frequency band: LTE Band 41/20MHz/QPSK/1RB 0Offset.
 - III. The worst configuration of 2.4GHz WLAN: 802.11b/1Mbps.
6. The test plans of OTT VoIP performed follows the given example.
7. The T-Coil measurement procedure given of OTT VoIP should be applied:

Step 1: Comparing the output power of EDGE, HSPA, LTE, and WLAN, the maximum output power including tune-up tolerance was selected to perform codec investigation of Z axial, recording the results of ABM1, ABM2, SNR and frequency response at the same time.

Step 2: Per step 1, selecting the worst codec of EDGE for GSM, HSPA for UMTS, LTE and WLAN to perform the T-Coil testing of Z axial and Y transversal, and the test results would be recorded in the report.
8. For OTT VoIP codec investigation test reduction that all of air interfaces have the same codec configuration, therefore the worst codec investigation for LTE Band 2 will be used to testing all of air interfaces.

➤ **Audio Level and Gain Calibration**

1. A more conservative input reference level of -20dBm0 would be used to audio calibration.
2. The adjusted gain measurements are based on the external Digital Analog Converter (DAC).
3. Three way audio files (sine wave, 1kHz voice and 300-3000 kHz) will be sent from the DASY 5 PC to the AMMI, and the to the ADC.
4. The Helmholtz resonator measurements the field strength, which represents the AMMI to ADC input sensitivity.



5. The linear gain levels for EDGE, HSPA, LTE and Wi-Fi as below:

Signal Type	Duration (s)	Peak to RMS (dB)	RMS (dB)	Gain Factor	Gain Setting
48k_voice_1kHz	1	17.3	-11.3	5.21	36.34
48k_voice_300-3000kHz	2	22.8	-17.2	9.52	71.13

➤ **Codec Investigation**

Code	Google Duo(Kbps)			Android dialing(Kbps)				
	OPUS			AMR NB	GSM	GSM EFR	PCMA	PCMU
GSM 850/189	6	40	75	12.2	13	12.2	64	64
ABM 1(dBA/m)	3.88	2.25	8.14	4.91	7.22	5.44	9.33	9.36
ABM 2(dBA/m)	-29.18	-29.57	-28.90	-25.56	-24.61	-26.05	-25.55	-25.33
SNR(dB)	33.06	31.82	37.04	30.47	31.83	31.49	34.88	34.69
Fre. Response	Pass	Pass	Pass	Pass	Pass	Pass	Pass	Pass

Note: The worst codec for ARM NB 12.2Kbps will be used to testing T-Coil.

➤ **Test Results for OTT VoIP**

Air Interface	Mode	Channel	Probe Position	ABM1 dB (A/m)	ABM2 dB (A/m)	SNR (dB)	T Rating	Frequency Response
GSM 850	EDGE 4TX Slots	189	Axial (Z)	-11.30	-41.48	30.18	T4	Pass
			Transversal (Y)	-5.61	-30.20	24.59	T3	
GSM 1900	EDGE 4TX Slots	661	Axial (Z)	-12.31	-43.90	31.59	T4	Pass
			Transversal (Y)	-5.33	-29.84	24.51	T3	
WCDMA II	HSPA	9400	Axial (Z)	-12.72	-49.18	36.46	T4	Pass
			Transversal (Y)	-2.24	-27.66	25.42	T3	
WCDMA IV	HSPA	1413	Axial (Z)	-12.26	-47.38	35.12	T4	Pass
			Transversal (Y)	-2.10	-27.41	25.31	T3	
WCDMA V	HSPA	4182	Axial (Z)	-13.19	-47.51	34.32	T4	Pass
			Transversal (Y)	-2.38	-27.80	25.42	T3	
CDMA BC0	EVDO	384	Axial (Z)	-13.60	-47.71	34.11	T4	Pass
			Transversal (Y)	-2.30	-50.87	48.57	T4	
CDMA BC1	EVDO	600	Axial (Z)	9.58	-54.54	64.12	T4	Pass
			Transversal (Y)	-1.90	-50.02	48.12	T4	
CDMA BC10	EVDO	580	Axial (Z)	-12.51	-46.67	34.16	T4	Pass
			Transversal (Y)	-5.72	-50.03	44.31	T4	



LTE Band 2	20MHz_QPSK 1RB_0Offset	18900	Axial (Z)	-12.18	-46.37	34.19	T4	Pass
			Transversal (Y)	-4.11	-29.40	25.29	T3	
LTE Band 41	20MHz_QPSK 1RB_0Offset	40620	Axial (Z)	-17.61	-45.20	27.59	T3	Pass
			Transversal (Y)	-2.77	-29.21	26.44	T3	
WLAN 2.4GHz	802.11b 1Mbps	6	Axial (Z)	-4.33	-51.62	47.29	T4	Pass
			Transversal (Y)	-10.37	-46.98	36.61	T4	



10. Uncertainty Assessment

Error Description	Uncertainty Value (±%)	Probability	Divisor	(Ci) ABM1	(Ci) ABM2	Standard Uncertainty (ABM1) (±%)	Standard Uncertainty (ABM2) (±%)
Probe Sensitivity							
Reference level	3.0	N	1	1	1	3.0	3.0
AMCC geometry	0.4	R	1.732	1	1	0.2	0.2
AMCC current	1.0	R	1.732	0.7	0.7	0.6	0.6
Probe positioning during calibrate	0.1	R	1.732	1	1	0.1	0.1
Noise contribution	0.7	R	1.732	0.0143	1	0.0	0.4
Frequency slope	5.9	R	1.732	0.1	1	0.3	3.5
Probe System							
Repeatability/drift	1.0	R	1.732	1	1	0.6	0.6
Linearity/dynamic range	0.6	R	1.732	1	1	0.4	0.4
Acoustic noise	1.0	R	1.732	0.1	1	0.1	0.6
Probe angle	2.3	R	1.732	1	1	1.4	1.4
Spectral processing	0.9	R	1.732	1	1	0.5	0.5
Integration time	0.6	N	1	1	5	0.6	3.0
Field disturbance	0.2	R	1.732	1	1	0.1	0.1
Test Signal							
Reference signal spectral response	0.6	R	1.732	0	1	0.0	0.4
Positioning							
Probe positioning	1.9	R	1.732	1	1	1.1	1.1
Phantom thickness	0.9	R	1.732	1	1	0.5	0.5
EUT positioning	1.9	N	1	0.78	0.71	0.1	0.1
External contributions							
RF interference	0.0	R	1.732	1	0.3	0.0	0.0
Test signal variation	2.0	R	1.732	1	1	1.2	1.2
Combined Std. Uncertainty						4.1	6.1
Coverage Factor for 95 %						K=2	K=2
Expanded STD Uncertainty						8.1	12.3



Annex A General Information

1. Identification of the Responsible Testing Laboratory

Laboratory Name:	Morlab Laboratory of Shenzhen Morlab Communications Technology Co., Ltd.
Laboratory Address:	FL. 3, Building A, FeiYang Science Park, No.8 LongChang Road, Block 67, BaoAn District, ShenZhen, GuangDong Province, P. R. China
Telephone:	+86 755 36698555
Facsimile:	+86 755 36698525

2. Identification of the Responsible Testing Location

Name:	Morlab Laboratory of Shenzhen Morlab Communications Technology Co., Ltd.
Address:	FL. 3, Building A, FeiYang Science Park, No.8 LongChang Road, Block 67, BaoAn District, ShenZhen, GuangDong Province, P. R. China

Note:

The main report is end here and the other appendix (B,C,D,E) will be submitted separately.

***** END OF MAIN REPORT *****