



# FCC RF Test Report

**APPLICANT** : Bullitt Group  
**EQUIPMENT** : Rugged Smart Phone  
**BRAND NAME** : Motorola  
**MODEL NAME** : BM2S1E  
**FCC ID** : ZL5BM2S1EE  
**STANDARD** : 47 CFR Part 2, 22, 24, 27  
**CLASSIFICATION** : PCS Licensed Transmitter Held to Ear (PCE)  
**TEST DATE(S)** : Nov. 16, 2022 ~ Dec. 28, 2022

We, Sporton International Inc. (Shenzhen), would like to declare that the tested sample has been evaluated in accordance with the procedures given in ANSI C63.26-2015 and shown compliance with the applicable technical standards.

The test results in this report apply exclusively to the tested model / sample. Without written approval of Sporton International Inc. (Shenzhen), the test report shall not be reproduced except in full.

Jason Jia

Approved by: Jason Jia



**Sporton International Inc. (ShenZhen)**

**1/F, 2/F, Bldg 5, Shiling Industrial Zone, Xinwei Village, Xili, Nanshan, Shenzhen, 518055**

**People's Republic of China**



TABLE OF CONTENTS

REVISION HISTORY... 3
SUMMARY OF TEST RESULT ... 4
1 GENERAL DESCRIPTION ... 5
1.1 Applicant ... 5
1.2 Manufacturer ... 5
1.3 Product Feature of Equipment Under Test ... 5
1.4 Product Specification of Equipment Under Test ... 5
1.5 Modification of EUT ... 6
1.6 Maximum ERP/EIRP Power and Emission Designator ... 6
1.7 Testing Location ... 9
1.8 Test Software ... 9
1.9 Applicable Standards ... 9
2 TEST CONFIGURATION OF EQUIPMENT UNDER TEST ... 10
2.1 Test Mode ... 10
2.2 Connection Diagram of Test System ... 11
2.3 Support Unit used in test configuration and system ... 12
2.4 Measurement Results Explanation Example ... 12
2.5 Frequency List of Low/Middle/High Channels ... 13
3 CONDUCTED TEST ITEMS ... 16
3.1 Measuring Instruments ... 16
3.2 Test Setup ... 16
3.3 Test Result of Conducted Test ... 16
3.4 Conducted Output Power and ERP/EIRP ... 17
3.5 Peak-to-Average Ratio ... 18
3.6 Occupied Bandwidth ... 19
3.7 Conducted Band Edge ... 20
3.8 Conducted Spurious Emission ... 22
3.9 Frequency Stability ... 23
4 RADIATED TEST ITEMS ... 24
4.1 Measuring Instruments ... 24
4.2 Test Setup ... 24
4.3 Test Result of Radiated Test ... 25
4.4 Radiated Spurious Emission ... 26
5 LIST OF MEASURING EQUIPMENT ... 27
6 UNCERTAINTY OF EVALUATION ... 28
APPENDIX A. TEST RESULTS OF CONDUCTED TEST
APPENDIX B. TEST RESULTS OF RADIATED TEST
APPENDIX C. TEST SETUP PHOTOGRAPHS





## SUMMARY OF TEST RESULT

Report Section	FCC Rule	Description	Limit	Result	Remark
3.4	§2.1046	Conducted Output Power	Reporting Only	PASS	-
	§22.913(a)(5)	Effective Radiated Power (5G NR n5)	ERP < 7 Watt		
	§24.232(c) §27.50(h)(2)	Equivalent Isotropic Radiated Power (5G NR n2) (5G NR n7, n41, n38)	EIRP < 2Watt		
3.5	§24.232(d)	Peak-to-Average Ratio	<13 dB	PASS	-
3.6	§2.1049	Occupied Bandwidth	Reporting Only	PASS	-
3.7	§2.1051 §22.917(a) §24.238(a)	Conducted Band Edge Measurement (5G NR n5) (5G NR n2)	< 43+10log <sub>10</sub> (P[Watts])	PASS	-
	§27.53(m)(4)	Conducted Band Edge Measurement (5G NR n7, n41, n38)	§27.53(m)(4)		
3.8	§2.1051 §22.917(a) §24.238(a)	Conducted Spurious Emission (5G NR n5) (5G NR n2)	< 43+10log <sub>10</sub> (P[Watts])	PASS	-
	§2.1051 §27.53(m)(4)	Conducted Spurious Emission (5G NR n7, n41, n38)	< 55+10log <sub>10</sub> (P[Watts])		
3.9	§2.1055 §22.355	Frequency Stability Temperature & Voltage	< 2.5 ppm for Part 22	PASS	-
	§24.235 §27.54		Within Authorized Band		
4.4	§2.1053 §22.917(a) §24.238(a)	Radiated Spurious Emission (5G NR n5) (5G NR n2)	< 43+10log <sub>10</sub> (P[Watts])	PASS	Under limit 28.21 dB at 10104.360 MHz
	§2.1053 §27.53(m)(4)	Radiated Spurious Emission (5G NR n7, n41, n38)	< 55+10log <sub>10</sub> (P[Watts])		

**Note:** This is the change FCC ID report. Since no changes have been made to this device, all test cases were leveraged from original report (FG201410-01C).

### Declaration of Conformity:

The test results with all measurement uncertainty excluded are presented in accordance with the regulation limits or requirements declared by manufacturers.

### Comments and Explanations:

The declared of product specification for EUT presented in the report are provided by the manufacturer, and the manufacturer takes all the responsibilities for the accuracy of product specification.



# 1 General Description

## 1.1 Applicant

**Bullitt Group**

One Valpy, Valpy Street, Reading, Berkshire, RG1 1AR, United Kingdom

## 1.2 Manufacturer

**Bullitt Mobile Limited**

One Valpy, Valpy Street, Reading, Berkshire, RG1 1AR, United Kingdom

## 1.3 Product Feature of Equipment Under Test

Product Feature	
Equipment	Rugged Smart Phone
Brand Name	Motorola
Model Name	BM2S1E
FCC ID	ZL5BM2S1EE
IMEI Code	Conducted : 351416010000076/351416010002072 Radiation : 351416010000050/351416010002056
EUT Stage	Identical Prototype

## 1.4 Product Specification of Equipment Under Test

Standards-related Product Specification	
Tx Frequency	5G NR n2 : 1850 MHz ~ 1910 MHz 5G NR n5 : 824 MHz ~ 849 MHz 5G NR n7 : 2500 MHz ~ 2570 MHz 5G NR n38 : 2570 MHz ~ 2620 MHz 5G NR n41 : 2496 MHz ~ 2690 MHz
Rx Frequency	5G NR n2 : 1930 MHz ~ 1990 MHz 5G NR n5 : 869 MHz ~ 894 MHz 5G NR n7 : 2620 MHz ~ 2690 MHz 5G NR n38 : 2570 MHz ~ 2620 MHz 5G NR n41 : 2496 MHz ~ 2690 MHz
Bandwidth	n2/n5/n7(15kHz): 5MHz / 10MHz / 15MHz / 20MHz n2/n5/n7(30kHz): 10MHz / 15MHz / 20MHz n38(15kHz): 5MHz / 10MHz / 15MHz / 20MHz / 25MHz / 30MHz / 40MHz n38(30kHz): 10MHz / 15MHz / 20MHz / 25MHz / 30MHz / 40MHz n41(15kHz): 10MHz / 15MHz / 20MHz / 30MHz / 40MHz / 50MHz n41(30kHz) : 10MHz / 15MHz / 20MHz / 30MHz / 40MHz / 50MHz / 60MHz / 80MHz / 90MHz / 100MHz
SCS	15kHz, 30kHz
Antenna Gain	<Ant. 1> n2: -2.5 dBi n5: -5.0 dBi <Ant. 2>



	n7: -2.6 dBi n38: -2.6 dBi n41: -2.6 dBi <Ant. 7> n2: -3.5 dBi n5: -7.0 dBi
Type of Modulation	CP-OFDM: QPSK / 16QAM / 64QAM / 256QAM DFT-s-OFDM: PI/2 BPSK / QPSK / 16QAM / 64QAM / 256QAM

**Remark:**

1. The maximum ERP/EIRP is calculated from max output power and max antenna gain, only the maximum ERP/EIRP are shown in the report, 5G NR n2/n5 for Ant. 1 and n7/n38/n41 for Ant. 2.
2. All the supported ENDC combinations are verified conducted power, only the ENDC combination with highest power are shown in the report.
3. 5G NR n2/n7/n38/n41 support SA mode only.
4. 5G NR n5 support SA mode and NSA mode. According to the maximum power between SA and NSA mode, SA covers NSA mode.
5. The EN-DC mode combination could be referred to the product spec.
6. 5G NR n2/n5/n7 SCS15kHz covers SCS30kHz according to the maximum power.

### 1.5 Modification of EUT

No modifications are made to the EUT during all test items.

### 1.6 Maximum ERP/EIRP Power and Emission Designator

5G NR n2_Ant.1(15kHz)		PI/2 BPSK / QPSK		16QAM / 64QAM / 256QAM	
BW (MHz)	Frequency Range (MHz)	Maximum EIRP(W)	Emission Designator (99%OBW)	Maximum EIRP(W)	Emission Designator (99%OBW)
5	1852.5 ~ 1907.5	0.1125	4M48G7D	0.0935	4M47W7D
10	1855.0 ~ 1905.0	0.1089	9M27G7D	0.0897	9M28W7D
15	1857.5 ~ 1902.5	0.1130	14M1G7D	0.0925	14M1W7D
20	1860.0 ~ 1900.0	0.1135	18M9G7D	0.0923	18M9W7D

5G NR n5_Ant.1(15kHz)		PI/2 BPSK / QPSK		16QAM / 64QAM / 256QAM	
BW (MHz)	Frequency Range (MHz)	Maximum ERP(W)	Emission Designator (99%OBW)	Maximum ERP(W)	Emission Designator (99%OBW)
5	826.5 ~ 846.5	0.0406	4M47G7D	0.0333	4M47W7D
10	829.0 ~ 844.0	0.0410	9M27G7D	0.0316	9M28W7D
15	831.5 ~ 841.5	0.0363	14M1G7D	0.0269	14M1W7D
20	834.0 ~ 839.0	0.0415	18M9G7D	0.0328	18M9W7D



5G NR n7_Ant.2(15kHz)		PI/2 BPSK / QPSK		16QAM / 64QAM / 256QAM	
BW (MHz)	Frequency Range (MHz)	Maximum EIRP(W)	Emission Designator (99%OBW)	Maximum EIRP(W)	Emission Designator (99%OBW)
5	2502.5 ~ 2567.5	0.1026	4M46G7D	0.0838	4M47W7D
10	2505.0 ~ 2565.0	0.0995	9M28G7D	0.0817	9M30W7D
15	2507.5 ~ 2562.5	0.1023	14M1G7D	0.0836	14M1W7D
20	2510.0 ~ 2560.0	0.1038	18M9G7D	0.0849	18M9W7D

5G NR n38_Ant.2(15kHz)		PI/2 BPSK / QPSK		16QAM / 64QAM / 256QAM	
BW (MHz)	Frequency Range (MHz)	Maximum EIRP(W)	Emission Designator (99%OBW)	Maximum EIRP(W)	Emission Designator (99%OBW)
5	2572.5 ~ 2617.5	0.1012	4M49G7D	0.0780	4M47W7D
10	2575.0 ~ 2615.0	0.1086	9M28G7D	0.0867	9M28W7D
15	2577.5 ~ 2612.5	0.1086	14M1G7D	0.0863	14M1W7D
20	2580.0 ~ 2610.0	0.1072	18M9G7D	0.0851	18M9W7D
25	2582.5 ~ 2607.5	0.0986	23M8G7D	0.0757	23M8W7D
30	2585.0 ~ 2605.0	0.0953	28M6G7D	0.0755	28M5W7D
40	2590.0 ~ 2600.0	0.1094	38M6G7D	0.0789	38M6W7D

5G NR n38_Ant.2(30kHz)		PI/2 BPSK / QPSK		16QAM / 64QAM / 256QAM	
BW (MHz)	Frequency Range (MHz)	Maximum EIRP(W)	Emission Designator (99%OBW)	Maximum EIRP(W)	Emission Designator (99%OBW)
10	2575.0 ~ 2615.0	0.1009	8M58G7D	0.0817	8M60W7D
15	2577.5 ~ 2612.5	0.1000	13M5G7D	0.0824	13M6W7D
20	2580.0 ~ 2610.0	0.1000	18M2G7D	0.0826	18M2W7D
25	2582.5 ~ 2607.5	0.1000	23M2G7D	0.0813	23M3W7D
30	2585.0 ~ 2605.0	0.0984	27M8G7D	0.0760	27M9W7D
40	2590.0 ~ 2600.0	0.1019	37M8G7D	0.0798	37M8W7D



5G NR n41_Ant.2(15kHz)		PI/2 BPSK / QPSK		16QAM / 64QAM / 256QAM	
BW (MHz)	Frequency Range (MHz)	Maximum EIRP(W)	Emission Designator (99%OBW)	Maximum EIRP(W)	Emission Designator (99%OBW)
10	2501.01 ~ 2685.00	0.0989	9M28G7D	0.0832	9M28W7D
15	2503.50 ~ 2682.495	0.0991	14M1G7D	0.0820	14M1W7D
20	2506.005 ~ 2679.99	0.0948	18M9G7D	0.0782	18M9W7D
30	2511.00 ~ 2674.995	0.0871	28M6G7D	0.0695	28M5W7D
40	2516.01 ~ 2670.00	0.0818	38M6G7D	0.0652	38M6W7D
50	2521.005 ~ 2664.99	0.1143	48M2G7D	0.0955	48M2W7D

5G NR n41_Ant.2(30kHz)		PI/2 BPSK / QPSK		16QAM / 64QAM / 256QAM	
BW (MHz)	Frequency Range (MHz)	Maximum EIRP(W)	Emission Designator (99%OBW)	Maximum EIRP(W)	Emission Designator (99%OBW)
10	2501.01 ~ 2685.00	0.1019	8M58G7D	0.0863	8M60W7D
15	2503.50 ~ 2682.48	0.1000	13M5G7D	0.0826	13M6W7D
20	2506.02 ~ 2679.99	0.0991	18M2G7D	0.0839	18M2W7D
30	2511.00 ~ 2674.98	0.0946	27M8G7D	0.0785	27M9W7D
40	2516.01 ~ 2670.00	0.0904	37M8G7D	0.0752	37M8W7D
50	2521.02 ~ 2664.99	0.0942	47M5G7D	0.0782	47M5W7D
60	2526.00 ~ 2659.98	0.0927	57M9G7D	0.0773	57M8W7D
80	2536.02 ~ 2649.99	0.0887	77M4G7D	0.0724	77M5W7D
90	2541.00 ~ 2644.98	0.0847	87M3G7D	0.0700	87M5W7D
100	2546.01 ~ 2640.00	0.1026	97M1G7D	0.0804	97M3W7D

Note:

1. 5G NR n41 overlaps the entire frequency range of 5G NR n38. Therefore, the test results provided in this report covers 5G NR n41 as well as 5G NR n38, except for BW 5MHz/25MHz, it is tested in the report.
2. All modulations have been tested, only the worst test results of PSK & QAM are shown in the report.



## 1.7 Testing Location

Sporton International Inc. (ShenZhen) is accredited to ISO/IEC 17025:2017 by American Association for Laboratory Accreditation with Certificate Number 5145.01.

<b>Test Firm</b>	Sporton International Inc. (ShenZhen)		
<b>Test Site Location</b>	1/F, 2/F, Bldg 5, Shiling Industrial Zone, Xinwei Village, Xili, Nanshan, Shenzhen, 518055 People's Republic of China TEL: +86-755-86379589 FAX: +86-755-86379595		
<b>Test Site No.</b>	<b>Sporton Site No.</b>	<b>FCC Designation No.</b>	<b>FCC Test Firm Registration No.</b>
	TH01-SZ	CN1256	421272

<b>Test Firm</b>	Sporton International Inc. (ShenZhen)		
<b>Test Site Location</b>	101, 1st Floor, Block B, Building 1, No. 2, Tengfeng 4th Road, Fenghuang Community, Fuyong Street, Baoan District, Shenzhen City Guangdong Province China 518103 TEL: +86-755-33202398		
<b>Test Site No.</b>	<b>Sporton Site No.</b>	<b>FCC Designation No.</b>	<b>FCC Test Firm Registration No.</b>
	03CH03-SZ	CN1256	421272

## 1.8 Test Software

Item	Site	Manufacturer	Name	Version
1.	03CH03-SZ	AUDIX	E3	6.2009-8-24

## 1.9 Applicable Standards

According to the specifications of the manufacturer, the EUT must comply with the requirements of the following standards:

- ♦ 47 CFR Part 2, 22, 24, 27
- ♦ ANSI C63.26-2015
- ♦ FCC KDB 971168 D01 Power Meas License Digital Systems v03r01
- ♦ FCC KDB 412172 D01 Determining ERP and EIRP v01r01

**Remark:**

All test items were verified and recorded according to the standards and without any deviation during the test.

## 2 Test Configuration of Equipment Under Test

### 2.1 Test Mode

Antenna port conducted and radiated test items are performed according to KDB 971168 D01 Power Meas License Digital Systems v03r01 with maximum output power.

For radiated measurement, pre-scanned in three orthogonal panels, X, Y, Z. The worst cases (X plane) were recorded in this report.

The device is investigated from 30MHz to 10 times of fundamental signal for radiated spurious emission test under different RB size/offset and modulations in exploratory test. Subsequently, only the worst case emissions are reported.

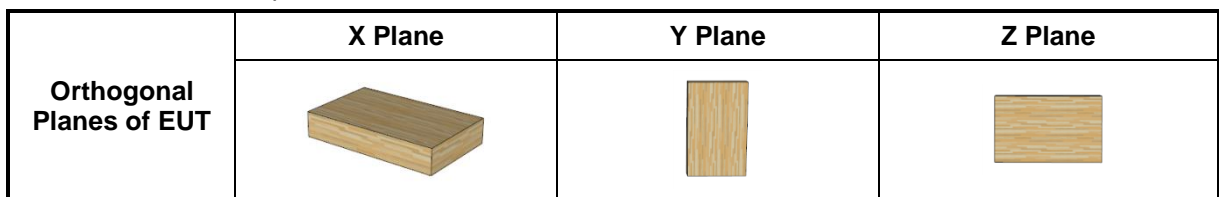

Test Items	5G NR	Bandwidth (MHz)												Modulation					RB #		Test Channel							
		5	10	15	20	25	30	40	50	60	70	80	90	100	PI/2 BPSK	QPSK	16QAM	64QAM	256QAM	1	Full	L	M	H				
Max. Output Power	n2	v	v	v	v	-	-	-	-	-	-	-	-	-	v	v	v	v	v	v	v	v	v	v	v	v	v	
	n5	v	v	v	v	-	-	-	-	-	-	-	-	-	v	v	v	v	v	v	v	v	v	v	v	v	v	v
	n7	v	v	v	v				-	-	-	-	-	-	v	v	v	v	v	v	v	v	v	v	v	v	v	v
	n38	v	v	v	v	v	v	v	-	-	-	-	-	-	v	v	v	v	v	v	v	v	v	v	v	v	v	v
	n41	-	v	v	v	-	v	v	v	v	-	v	v	v	v	v	v	v	v	v	v	v	v	v	v	v	v	v
Peak-to-Average Ratio	n2				v	-	-	-	-	-	-	-	-	-	v	v					v			v				
	n5				v	-	-	-	-	-	-	-	-	-	v	v					v			v				
	n7				v				-	-	-	-	-	-	v	v					v			v				
	n41	-			v	-									v	v					v			v				
26dB and 99% Bandwidth	n2	v	v	v	v	-	-	-	-	-	-	-	-	-		v	v	v	v		v			v				
	n5	v	v	v	v	-	-	-	-	-	-	-	-	-		v	v	v	v		v			v				
	n7	v	v	v	v				-	-	-	-	-	-		v	v	v	v		v			v				
	n38	v				v			-	-	-	-	-	-		v	v	v	v		v			v				
	n41	-	v	v	v	-	v	v	v	v		v	v	v		v	v	v	v		v			v				
Conducted Band Edge	n2	v	v		v	-	-	-	-	-	-	-	-	-	v	v				v	v	v			v		v	
	n5	v	v		v	-	-	-	-	-	-	-	-	-	v	v				v	v	v			v		v	
	n7	v	v		v				-	-	-	-	-	-	v	v				v	v	v			v		v	
	n38	v				v			-	-	-	-	-	-	v	v				v	v	v			v		v	
	n41	-	v		v	-			v		-				v	v	v				v	v	v			v		v
Conducted Spurious Emission	n2	v	v		v	-	-	-	-	-	-	-	-	-	v	v				v			v	v	v		v	
	n5	v	v		v	-	-	-	-	-	-	-	-	-	v	v				v			v	v	v		v	
	n7	v	v		v				-	-	-	-	-	-	v	v				v			v	v	v		v	
	n38	v				v			-	-	-	-	-	-	v	v				v			v	v	v		v	
	n41	-	v		v	-			v		-				v	v	v				v			v	v	v		v



Test Items	5G NR	Bandwidth (MHz)												Modulation					RB #		Test Channel			
		5	10	15	20	25	30	40	50	60	70	80	90	100	PI/2 BPSK	QPSK	16QAM	64QAM	256QAM	1	Full	L	M	H
Frequency Stability	n2				v	-	-	-	-	-	-	-	-	-		v				v			v	
	n5				v	-	-	-	-	-	-	-	-	-		v				v			v	
	n7				v	-	-	-	-	-	-	-	-	-		v				v			v	
	n41	-			v	-										v				v			v	
E.R.P / E.I.R.P	n2	v	v	v	v	-	-	-	-	-	-	-	-	-	v	v	v	v	v	v	v	v	v	v
	n5	v	v	v	v	-	-	-	-	-	-	-	-	-	v	v	v	v	v	v	v	v	v	v
	n7	v	v	v	v	-	-	-	-	-	-	-	-	-	v	v	v	v	v	v	v	v	v	v
	n38	v	v	v	v	v	v	v	-	-	-	-	-	-	v	v	v	v	v	v	v	v	v	v
	n41	-	v	v	v	-	v	v	v	v		v	v	v	v	v	v	v	v	v	v	v	v	v
Radiated Spurious Emission	n2	Worst Case																				v		
	n5	Worst Case																				v		
	n7	Worst Case																				v		
	n41	Worst Case																				v		
Note	<ol style="list-style-type: none"> <li>The mark "v " means that this configuration is chosen for testing</li> <li>The mark "- " means that this bandwidth is not supported.</li> <li>The device is investigated from 30MHz to 10 times of fundamental signal for radiated spurious emission test under different RB size/offset and modulations in exploratory test. Subsequently, only the worst case emissions are reported.</li> <li>Test mode include SCS15KHz/30kHz test configuration could refer to Appendix A for details.</li> </ol>																							

## 2.2 Connection Diagram of Test System

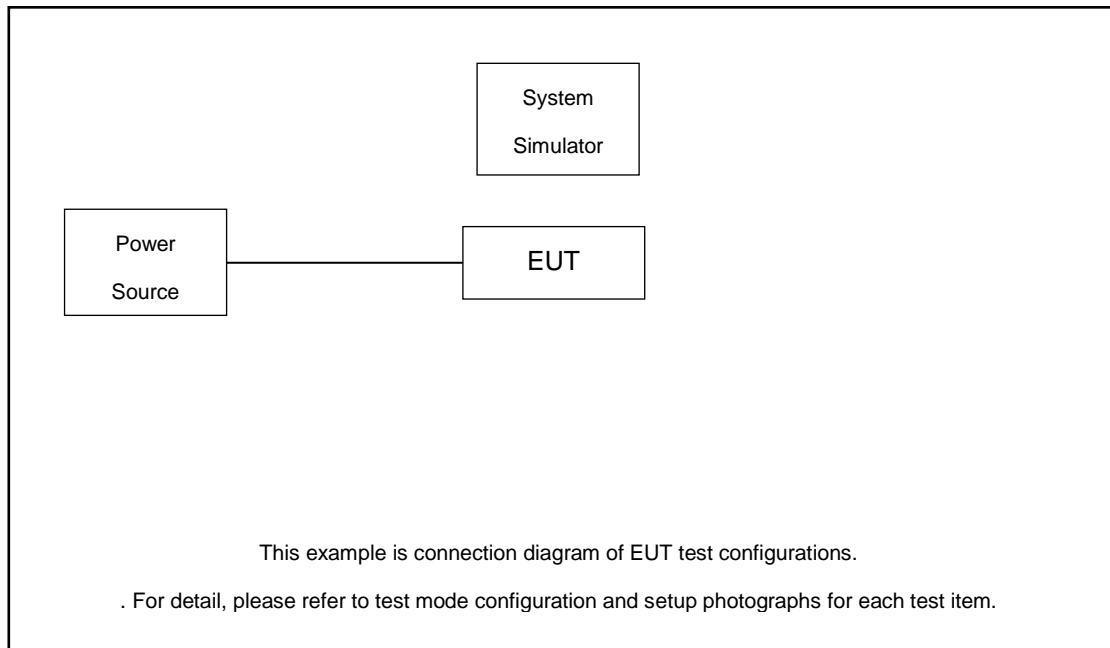

The EUT has been configuration operated in a manner tended to maximize its emission characteristics in a typical application.



### 2.3 Support Unit used in test configuration and system

Item	Equipment	Trade Name	Model No.	FCC ID	Data Cable	Power Cord
1.	DC Power Supply	GW	GPS-3030D	N/A	N/A	Unshielded, 1.8 m
2.	LTE Base Station	Anritsu	MT8821C	N/A	N/A	Unshielded, 1.8 m
3.	NR Base Station	Anritsu	MT8000A	N/A	N/A	Unshielded, 1.8 m

### 2.4 Measurement Results Explanation Example

**For all conducted test items:**

The offset level is set in the spectrum analyzer to compensate the RF cable loss between EUT conducted output port and spectrum analyzer. With the offset compensation, the spectrum analyzer reading level is exactly the EUT RF output level.

The spectrum analyzer offset is derived from RF cable loss.

$$\text{Offset} = \text{RF cable loss.}$$

Following shows an offset computation example with cable loss 8.0 dB.

Example :

$$\begin{aligned} \text{Offset(dB)} &= \text{RF cable loss(dB)}. \\ &= 8.0 \text{ (dB)} \end{aligned}$$



### 2.5 Frequency List of Low/Middle/High Channels

5G NR n2 Channel and Frequency List				
BW [MHz]	Channel/Frequency(MHz)	Lowest	Middle	Highest
20	Channel	372000	376000	380000
	Frequency	1860	1880	1900
15	Channel	371500	376000	380500
	Frequency	1857.5	1880	1902.5
10	Channel	371000	376000	381000
	Frequency	1855	1880	1905
5	Channel	370500	376000	381500
	Frequency	1852.5	1880	1907.5

5G NR n5 Channel and Frequency List				
BW [MHz]	Channel/Frequency(MHz)	Lowest	Middle	Highest
20	Channel	166800	167300	167800
	Frequency	834	836.5	839
15	Channel	166300	167300	168300
	Frequency	831.5	836.5	841.5
10	Channel	165800	167300	168800
	Frequency	829	836.5	844
5	Channel	165300	167300	169300
	Frequency	826.5	836.5	846.5

5G NR n7 Channel and Frequency List				
BW [MHz]	Channel/Frequency(MHz)	Lowest	Middle	Highest
20	Channel	502000	507000	512000
	Frequency	2510	2535	2560
15	Channel	501500	507000	512500
	Frequency	2507.5	2535	2562.5
10	Channel	501000	507000	513000
	Frequency	2505	2535	2565
5	Channel	500500	507000	513500
	Frequency	2502.5	2535	2567.5



5G NR n38 Channel and Frequency List				
BW [MHz]	Channel/Frequency(MHz)	Lowest	Middle	Highest
40	Channel	518000	519000	520000
	Frequency	2590	2595	2600
30	Channel	517000	519000	521000
	Frequency	2585	2595	2605
25	Channel	516500	519000	521500
	Frequency	2582.5	2595	2607.5
20	Channel	516000	519000	522000
	Frequency	2580	2595	2610
15	Channel	515500	519000	522500
	Frequency	2577.5	2595	2612.5
10	Channel	515000	519000	523000
	Frequency	2575	2595	2615
5	Channel	514500	518500	518500
	Frequency	2572.5	2592.5	2617.5

5G NR n41 Channel and Frequency List(30KHz)				
BW [MHz]	Channel/Frequency(MHz)	Lowest	Middle	Highest
100	Channel	509202	518598	528000
	Frequency	2546.01	2592.99	2640
90	Channel	508200	518598	528996
	Frequency	2541	2592.99	2644.98
80	Channel	507204	518598	529998
	Frequency	2536.02	2592.99	2649.99
60	Channel	505200	518598	531996
	Frequency	2526	2592.99	2659.98
50	Channel	504204	518598	532998
	Frequency	2521.02	2592.99	2664.99
40	Channel	503202	518598	534000
	Frequency	2516.01	2592.99	2670
30	Channel	502200	518598	534996
	Frequency	2511	2592.99	2674.98
20	Channel	501204	518598	535998
	Frequency	2506.02	2592.99	2679.99
15	Channel	500700	518598	536496
	Frequency	2503.5	2592.99	2682.48
10	Channel	500202	518598	537000
	Frequency	2501.01	2592.99	2685



5G NR n41 Channel and Frequency List(15KHz)				
BW [MHz]	Channel/Frequency(MHz)	Lowest	Middle	Highest
50	Channel	504201	518601	532998
	Frequency	2521.005	2593.005	2664.99
40	Channel	503202	518601	534000
	Frequency	2516.01	2593.005	2670
30	Channel	502200	518601	534999
	Frequency	2511	2593.005	2674.995
20	Channel	501201	518601	535998
	Frequency	2506.005	2593.005	2679.99
15	Channel	500700	518601	536499
	Frequency	2503.5	2593.005	2682.495
10	Channel	500202	518601	537000
	Frequency	2501.01	2593.005	2685

### 3 Conducted Test Items

#### 3.1 Measuring Instruments

See list of measuring instruments of this test report.

#### 3.2 Test Setup

##### 3.2.1 Conducted Output Power



##### 3.2.2 Peak-to-Average Ratio, Occupied Bandwidth ,Conducted Band-Edge and Conducted Spurious Emission



##### 3.2.3 Frequency Stability

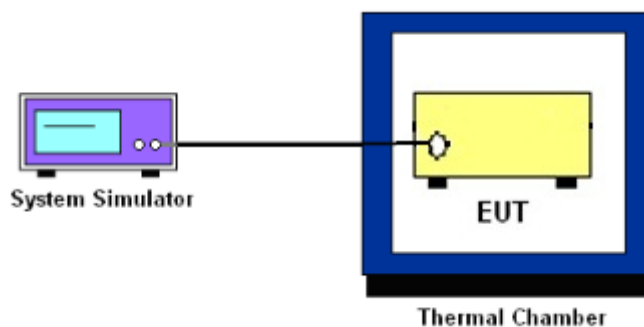

### 3.3 Test Result of Conducted Test

Please refer to Appendix A.





### 3.4 Conducted Output Power and ERP/EIRP

#### 3.4.1 Description of the Conducted Output Power Measurement and ERP/EIRP Measurement

A system simulator was used to establish communication with the EUT. Its parameters were set to force the EUT transmitting at maximum output power. The measured power in the radio frequency on the transmitter output terminals shall be reported.

The ERP of mobile transmitters must not exceed 7 Watts for 5G NR n5.

The EIRP of mobile transmitters must not exceed 2 Watts for 5G NR n2, n7, n38, n41.

According to KDB 412172 D01 Power Approach,

$EIRP = P_T + G_T - L_C$ ,  $ERP = EIRP - 2.15$ , where

$P_T$  = transmitter output power in dBm

$G_T$  = gain of the transmitting antenna in dBi

$L_C$  = signal attenuation in the connecting cable between the transmitter and antenna in dB

#### 3.4.2 Test Procedures

1. The testing follows ANSI C63.26 Section 5.2
2. The transmitter output port was connected to the system simulator.
3. Set EUT at maximum power through the system simulator.
4. Select lowest, middle, and highest channels for each band and different modulation.
5. Measure and record the power level from the system simulator.



## **3.5 Peak-to-Average Ratio**

### **3.5.1 Description of the PAR Measurement**

Power Complementary Cumulative Distribution Function (CCDF) curves provide a means for characterizing the power peaks of a digitally modulated signal on a statistical basis. A CCDF curve depicts the probability of the peak signal amplitude exceeding the average power level. Most contemporary measurement instrumentation include the capability to produce CCDF curves for an input signal provided that the instrument's resolution bandwidth can be set wide enough to accommodate the entire input signal bandwidth. In measuring transmissions in this band using an average power technique, the peak-to-average ratio (PAR) of the transmission may not exceed 13 dB.

### **3.5.2 Test Procedures**

1. The testing follows ANSI C63.26 Section 5.2.3.4 (CCDF).
2. The EUT was connected to spectrum and system simulator via a power divider.
3. Set the CCDF (Complementary Cumulative Distribution Function) option in spectrum analyzer.
4. The highest RF powers were measured and recorded the maximum PAPR level associated with a probability of 0.1 %.
5. Record the deviation as Peak to Average Ratio.



## 3.6 Occupied Bandwidth

### 3.6.1 Description of Occupied Bandwidth Measurement

The occupied bandwidth is the width of a frequency band such that, below the lower and above the upper frequency limits, the mean powers emitted are each equal to a specified percentage 0.5% of the total mean transmitted power.

The 26 dB emission bandwidth is defined as the frequency range between two points, one above and one below the carrier frequency, at which the spectral density of the emission is attenuated 26 dB below the maximum in-band spectral density of the modulated signal. Spectral density (power per unit bandwidth) is to be measured with a detector of resolution bandwidth equal to approximately 1.0% of the emission bandwidth.

### 3.6.2 Test Procedures

1. The testing follows ANSI C63.26 Section 5.4
2. The EUT was connected to spectrum analyzer and system simulator via a power divider.
3. The spectrum analyzer center frequency is set to the nominal EUT channel center frequency. The span range for the spectrum analyzer shall be between two and five times the anticipated OBW.
4. The nominal resolution bandwidth (RBW) shall be in the range of 1 to 5 % of the anticipated OBW, and the VBW shall be at least 3 times the RBW.
5. Set the detection mode to peak, and the trace mode to max hold.
6. Determine the reference value: Set the EUT to transmit a modulated signal. Allow the trace to stabilize. Set the spectrum analyzer marker to the highest level of the displayed trace.  
(this is the reference value)
7. Determine the “-26 dB down amplitude” as equal to (Reference Value – X).
8. Place two markers, one at the lowest and the other at the highest frequency of the envelope of the spectral display such that each marker is at or slightly below the “-X dB down amplitude” determined in step 6. If a marker is below this “-X dB down amplitude” value it shall be placed as close as possible to this value. The OBW is the positive frequency difference between the two markers.
9. Use the 99 % power bandwidth function of the spectrum analyzer and report the measured bandwidth.



### 3.7 Conducted Band Edge

#### 3.7.1 Description of Conducted Band Edge Measurement

22.917(a)

For operations in the 824 – 849 MHz band, the FCC limit is  $43 + 10\log_{10}(P[\text{Watts}])$  dB below the transmitter power  $P(\text{Watts})$  in a 100kHz bandwidth. However, in the 1MHz bands immediately outside and adjacent to the licensee's frequency block, a resolution bandwidth of at least one percent of the emission bandwidth of the fundamental emission of the transmitter may be employed.

24.238 (a)

For operations in the 1850-1910 and 1930-1990 MHz band, the FCC limit is  $43 + 10\log_{10}(P[\text{Watts}])$  dB below the transmitter power  $P(\text{Watts})$  in a 1MHz bandwidth. However, in the 1 MHz bands immediately outside and adjacent to the frequency block a resolution bandwidth of at least one percent of the emission bandwidth of the fundamental emission of the transmitter may be employed.

27.53(m)(4)

For mobile digital stations, the attenuation factor shall be not less than  $40 + 10 \log (P)$  dB on all frequencies between the channel edge and 5 megahertz from the channel edge,  $43 + 10 \log (P)$  dB on all frequencies between 5 megahertz and X megahertz from the channel edge, and  $55 + 10 \log (P)$  dB on all frequencies more than X megahertz from the channel edge, where X is the greater of 6 megahertz or the actual emission bandwidth as defined in paragraph (m)(6) of this section. In addition, the attenuation factor shall not be less that  $43 + 10 \log (P)$  dB on all frequencies between 2490.5 MHz and 2496 MHz and  $55 + 10 \log (P)$  dB at or below 2490.5 MHz. Mobile Satellite Service licensees operating on frequencies below 2495 MHz may also submit a documented interference complaint against BRS licensees operating on channel BRS Channel 1 on the same terms and conditions as adjacent channel BRS or EBS licensees.



### 3.7.2 Test Procedures

1. The testing follows ANSI C63.26 section 5.7
2. The EUT was connected to spectrum analyzer and system simulator via a power divider.
3. The band edges of low and high channels for the highest RF powers were measured.
4. Set RBW  $\geq$  1%/2% EBW in the 1MHz band immediately outside and adjacent to the band edge.
5. Beyond the 1 MHz band from the band edge, RBW=1MHz was used or a narrower RBW was used (generally limited to no less than 1% of the OBW) and the measured power was integrated over the full required measurement bandwidth.
6. Set spectrum analyzer with RMS detector.
7. Offset has included the duty factor for Band n38/n41. Duty factor =  $10 \log(1/x)$ , where x is the measured duty cycle
8. The RF fundamental frequency should be excluded against the limit line in the operating frequency band.
9. Checked that all the results comply with the emission limit line.

Example:

The limit line is derived from  $43 + 10\log(P)$ dB below the transmitter power P(Watts)  
=  $P(W) - [43 + 10\log(P)]$  (dB)  
=  $[30 + 10\log(P)]$  (dBm) -  $[43 + 10\log(P)]$  (dB) = -13dBm.

10. For 5G NR n7/n38/n41, the other 40 dB, and 55 dB have additionally applied same calculation above.
11. When using the integration method, the starting frequency of the integration shall be centered at one-half of the RBW away from the band edge.



## 3.8 Conducted Spurious Emission

### 3.8.1 Description of Conducted Spurious Emission Measurement

The power of any emission outside of the authorized operating frequency ranges must be lower than the transmitter power (P) by a factor of at least  $43 + 10 \log (P)$  dB.

For 5G NR n7/n38/n41:

The power of any emission outside of the authorized operating frequency ranges must be lower than the transmitter power (P) by a factor of at least  $55 + 10 \log (P)$  dB.

It is measured by means of a calibrated spectrum analyzer and scanned from 30 MHz up to a frequency including its 10<sup>th</sup> harmonic.

### 3.8.2 Test Procedures

1. The testing follows ANSI C63.26 section 5.7
2. The EUT was connected to spectrum analyzer and system simulator via a power divider.
3. The RF output of EUT was connected to the spectrum analyzer by RF cable and attenuator. The path loss was compensated to the results for each measurement.
4. The middle channel for the highest RF power within the transmitting frequency was measured.
5. The conducted spurious emission for the whole frequency range was taken.
6. Make the measurement with the spectrum analyzer's RBW = 1MHz, VBW = 3MHz.
7. Set spectrum analyzer with RMS detector.
8. Offset has included the duty factor for Band n38/n41. Duty factor =  $10 \log (1/x)$ , where x is the measured duty cycle
9. Taking the record of maximum spurious emission.
10. The RF fundamental frequency should be excluded against the limit line in the operating frequency band.
11. The limit line is derived from  $43 + 10 \log (P)$  dB below the transmitter power P(Watts)  
=  $P(W) - [43 + 10 \log (P)]$  (dB)  
=  $[30 + 10 \log (P)]$  (dBm) -  $[43 + 10 \log (P)]$  (dB)  
= -13dBm.
12. For 5G NR n7/n38/n41  
The limit line is derived from  $55 + 10 \log (P)$  dB below the transmitter power P(Watts)  
=  $P(W) - [55 + 10 \log (P)]$  (dB)  
=  $[30 + 10 \log (P)]$  (dBm) -  $[55 + 10 \log (P)]$  (dB)  
= -25dBm.



### 3.9 Frequency Stability

#### 3.9.1 Description of Frequency Stability Measurement

The frequency stability shall be measured by variation of ambient temperature and variation of primary supply voltage to ensure that the fundamental emission stays within the authorized frequency block. The frequency stability of the transmitter shall be maintained within  $\pm 0.00025\%$  ( $\pm 2.5\text{ppm}$ ) of the center frequency.

#### 3.9.2 Test Procedures for Temperature Variation

1. The testing follows ANSI C63.26 section 5.6.4
2. The EUT was set up in the thermal chamber and connected with the system simulator.
3. With power OFF, the temperature was decreased to  $-30^{\circ}\text{C}$  and the EUT was stabilized before testing. Power was applied and the maximum change in frequency was recorded within one minute.
4. With power OFF, the temperature was raised in  $10^{\circ}\text{C}$  step up to  $50^{\circ}\text{C}$ . The EUT was stabilized at each step for at least half an hour. Power was applied and the maximum frequency change was recorded within one minute.

#### 3.9.3 Test Procedures for Voltage Variation

1. The testing follows ANSI C63.26 section 5.6.5
2. The EUT was placed in a temperature chamber at  $20\pm 5^{\circ}\text{C}$  and connected with the system simulator.
3. The power supply voltage to the EUT was varied from 85% to 115% of the nominal value for other than hand carried battery equipment.
4. For hand carried, battery powered equipment, reduce the primary ac or dc supply voltage to the battery operating end point, which shall be specified by the manufacturer.
5. The variation in frequency was measured for the worst case.

## 4 Radiated Test Items

### 4.1 Measuring Instruments

See list of measuring instruments of this test report.

### 4.2 Test Setup

#### 4.2.1 For radiated test below 30MHz

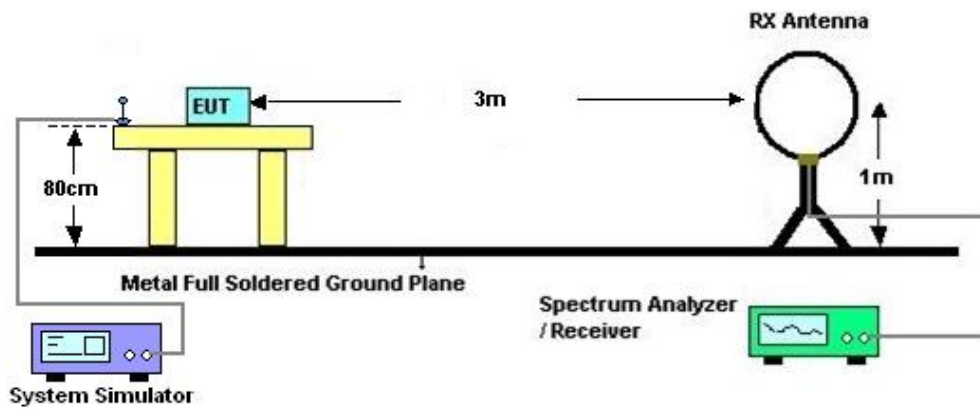

#### 4.2.2 For radiated test from 30MHz to 1GHz

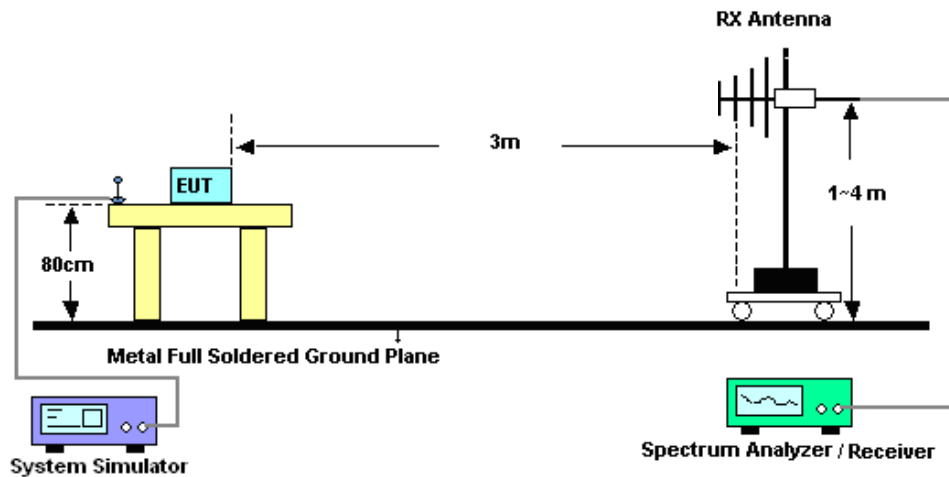



#### 4.2.3 For radiated test above 1GHz

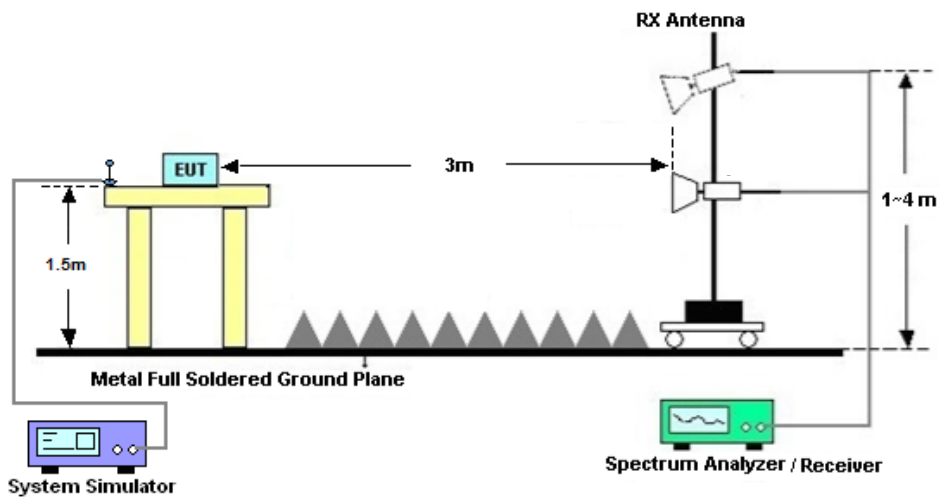

#### 4.3 Test Result of Radiated Test

The low frequency, which started from 9 kHz to 30MHz, was pre-scanned and the result which was 20dB lower than the limit line was not reported.

Please refer to Appendix B.



## 4.4 Radiated Spurious Emission

### 4.4.1 Description of Radiated Spurious Emission

The radiated spurious emission was measured by substitution method according to ANSI C63.26. The power of any emission outside of the authorized operating frequency ranges must be attenuated below the transmitter power (P) by a factor of at least  $43 + 10 \log (P)$  dB.

For 5G NR n7/n38/n41

The power of any emission outside of the authorized operating frequency ranges must be attenuated below the transmitter power (P) by a factor of at least  $55 + 10 \log (P)$  dB.

The spectrum is scanned from 30 MHz up to a frequency including its 10th harmonic.

### 4.4.2 Test Procedures

1. The testing follows ANSI C63.26 Section 5.5
2. The EUT was placed on a turntable with 0.8 meter height for frequency below 1GHz and 1.5 meter height for frequency above 1GHz respectively above ground.
3. The EUT was set 3 meters from the receiving antenna mounted on the antenna tower.
4. The table was rotated 360 degrees to determine the position of the highest spurious emission.
5. The height of the receiving antenna is varied between 1m to 4m to search the maximum spurious emission for both horizontal and vertical polarizations.
6. During the measurement, the system simulator parameters were set to force the EUT transmitting at maximum output power.
7. Make the measurement with the spectrum analyzer's RBW = 1MHz, VBW = 3MHz, taking the record of maximum spurious emission.
8. A horn antenna was substituted in place of the EUT and was driven by a signal generator.
9. Tune the output power of signal generator to the same emission level with EUT maximum spurious emission.
10.  $EIRP (dBm) = S.G. Power - Tx Cable Loss + Tx Antenna Gain$
11.  $ERP (dBm) = EIRP - 2.15$
12. The RF fundamental frequency should be excluded against the limit line in the operating frequency band.

The limit line is derived from  $43 + 10\log(P)$ dB below the transmitter power P(Watts)  
 $= P(W) - [43 + 10\log(P)] (dB)$   
 $= [30 + 10\log(P)] (dBm) - [43 + 10\log(P)] (dB)$   
 $= -13dBm.$

13. For 5G NR n7/n38/n41:

The limit line is derived from  $55 + 10\log(P)$ dB below the transmitter power P(Watts)The limit line is derived from  $55 + 10\log(P)$ dB below the transmitter power P(Watts)



## 5 List of Measuring Equipment

Instrument	Manufacturer	Model No.	Serial No.	Characteristics	Calibration Date	Test Date	Due Date	Remark
EMI Test Receiver&SA	Agilent	N9038A	MY52260185	20Hz~26.5GHz	Dec. 27, 2021	Nov. 16, 2022~ Dec. 28, 2022	Dec. 26, 2022	Conducted (TH01-SZ)
EMI Test Receiver&SA	Agilent	N9038A	MY52260185	20Hz~26.5GHz	Dec. 26, 2022		Dec. 25, 2023	Conducted (TH01-SZ)
Power Divider	TOJOIN	PS-2SM-04 265	60.06.020.007 7	0.4GHz~26.5GHz	Dec. 25, 2021	Nov. 16, 2022~ Dec. 28, 2022	Dec. 24, 2022	Conducted (TH01-SZ)
Power Divider	TOJOIN	PS-2SM-04 265	60.06.020.007 7	0.4GHz~26.5GHz	Dec. 24, 2022		Dec. 23, 2023	Conducted (TH01-SZ)
Thermal Chamber	Ten Billion Hongzhangroup	LP-150U	H2014081803	-40~+150°C	Jul. 07, 2022	Nov. 16, 2022~ Dec. 28, 2022	Jul. 06, 2023	Conducted (TH01-SZ)
EXA Spectrum Analyzer	KEYSIGHT	N9010A	MY55150213	10Hz~44GHz	Jul. 07, 2022	Dec. 07, 2022	Jul. 06, 2023	Radiation (03CH03-SZ)
Loop Antenna	R&S	HFH2-Z2	100354	9kHz~30MHz	Jul. 28, 2022	Dec. 07, 2022	Jul. 27, 2024	Radiation (03CH03-SZ)
Bilog Antenna	TeseQ	CBL6112D	35407	30MHz-2GHz	Oct. 19, 2022	Dec. 07, 2022	Oct. 18, 2023	Radiation (03CH03-SZ)
Double Ridge Horn Antenna	ETS-Lindgren	3117	00119436	1GHz~18GHz	Jul. 07, 2022	Dec. 07, 2022	Jul. 06, 2023	Radiation (03CH03-SZ)
HF Amplifier	MITEQ	TTA1840-35 -HG	1871923	18GHz~40GHz	Jul. 07, 2022	Dec. 07, 2022	Jul. 06, 2023	Radiation (03CH03-SZ)
SHF-EHF Horn	com-power	AH-840	101071	18Ghz-40GHz	Apr. 10, 2022	Dec. 07, 2022	Apr. 09, 2023	Radiation (03CH03-SZ)
LF Amplifier	Burgeon	BPA-530	102211	0.01~3000Mhz	Oct. 19, 2022	Dec. 07, 2022	Oct. 18, 2023	Radiation (03CH03-SZ)
HF Amplifier	KEYSIGHT	83017A	MY53270105	0.5GHz~26.5Ghz	Oct. 19, 2022	Dec. 07, 2022	Oct. 18, 2023	Radiation (03CH03-SZ)
AC Power Source	Chroma	61601	616010003043	N/A	Nov. 10, 2022	Dec. 07, 2022	Nov. 09, 2023	Radiation (03CH03-SZ)
Turn Table	Chaintek	T-200	N/A	0~360 degree	NCR	Dec. 07, 2022	NCR	Radiation (03CH03-SZ)
Antenna Mast	Chaintek	MBS-400	N/A	1 m~4 m	NCR	Dec. 07, 2022	NCR	Radiation (03CH03-SZ)

NCR: No Calibration Required



## 6 Uncertainty of Evaluation

The measurement uncertainties shown below were calculated in accordance with the requirements of ANSI 63.26-2015. All the measurement uncertainty value were shown with a coverage K=2 to indicate 95% level of confidence. The measurement data show herein meets or exceeds the CISPR measurement uncertainty values specified in CISPR 16-4-2 and can be compared directly to specified limit to determine compliance.

### Uncertainty of Conducted Measurement

Test Item	Uncertainty
Conducted Power	±1.34 dB
Conducted Emissions	±1.34 dB
Occupied Channel Bandwidth	±0.13 %

### Uncertainty of Radiated Emission Measurement (30 MHz ~ 1000 MHz)

Measuring Uncertainty for a Level of Confidence of 95% (U = 2Uc(y))	3.0dB
---	-------

### Uncertainty of Radiated Emission Measurement (1000 MHz ~ 18000 MHz)

Measuring Uncertainty for a Level of Confidence of 95% (U = 2Uc(y))	3.6dB
---	-------

### Uncertainty of Radiated Emission Measurement (18000 MHz ~ 40000 MHz)

Measuring Uncertainty for a Level of Confidence of 95% (U = 2Uc(y))	3.8dB
---	-------

----- THE END -----



## Appendix A. Test Results of Conducted Test

Test Engineer :	Jung Kuo	Temperature :	22~23°C
		Relative Humidity :	40~42%

# FR1 N2

## Transmitter Conducted Output Power And EIRP, ( $G_T - L_C$ )=-2.5dB

NR Band	SCS (kHz)	Bandwidth (MHz)	Arfcn	Freq (MHz)	Modulation	RB	Conducted Power(dBm)	EIRP (dBm)	EIRP (W)
2	15	5	370500	1852.5	DFT-s-OFDM QPSK	1@1	23.01	20.51	0.1125
2	15	5	370500	1852.5	DFT-s-OFDM 16 QAM	1@1	22.21	19.71	0.0935
2	15	5	376000	1880.0	DFT-s-OFDM QPSK	1@1	22.46	19.96	0.0991
2	15	5	376000	1880.0	DFT-s-OFDM 16 QAM	1@1	21.55	19.05	0.0804
2	15	5	381500	1907.5	DFT-s-OFDM QPSK	1@1	22.57	20.07	0.1016
2	15	5	381500	1907.5	DFT-s-OFDM 16 QAM	1@1	21.63	19.13	0.0818
2	15	10	371000	1855.0	DFT-s-OFDM QPSK	1@1	22.87	20.37	0.1089
2	15	10	371000	1855.0	DFT-s-OFDM 16 QAM	1@1	22.03	19.53	0.0897
2	15	10	376000	1880.0	DFT-s-OFDM QPSK	1@1	22.28	19.78	0.0951
2	15	10	376000	1880.0	DFT-s-OFDM 16 QAM	1@1	21.31	18.81	0.0760
2	15	10	381000	1905.0	DFT-s-OFDM QPSK	1@1	22.23	19.73	0.0940
2	15	10	381000	1905.0	DFT-s-OFDM 16 QAM	1@1	21.23	18.73	0.0746
2	15	15	371500	1857.5	DFT-s-OFDM QPSK	1@1	23.03	20.53	0.1130
2	15	15	371500	1857.5	DFT-s-OFDM 16 QAM	1@1	22.16	19.66	0.0925
2	15	15	376000	1880.0	DFT-s-OFDM QPSK	1@1	22.48	19.98	0.0995
2	15	15	376000	1880.0	DFT-s-OFDM 16 QAM	1@1	21.6	19.1	0.0813
2	15	15	380500	1902.5	DFT-s-OFDM QPSK	1@1	22.31	19.81	0.0957
2	15	15	380500	1902.5	DFT-s-OFDM 16 QAM	1@1	21.4	18.9	0.0776
2	15	20	372000	1860.0	DFT-s-OFDM PI/2 BPSK	50@25	22.93	20.43	0.1104

2	15	20	372000	1860.0	DFT-s-OFDM PI/2 BPSK	1@1	23.05	20.55	0.1135
2	15	20	372000	1860.0	DFT-s-OFDM PI/2 BPSK	1@104	22.6	20.1	0.1023
2	15	20	372000	1860.0	DFT-s-OFDM QPSK	50@25	22.94	20.44	0.1107
2	15	20	372000	1860.0	DFT-s-OFDM QPSK	1@1	22.97	20.47	0.1114
2	15	20	372000	1860.0	DFT-s-OFDM QPSK	1@104	22.62	20.12	0.1028
2	15	20	372000	1860.0	DFT-s-OFDM 16 QAM	50@25	21.97	19.47	0.0885
2	15	20	372000	1860.0	DFT-s-OFDM 16 QAM	1@1	22.15	19.65	0.0923
2	15	20	372000	1860.0	DFT-s-OFDM 16 QAM	1@104	21.61	19.11	0.0815
2	15	20	372000	1860.0	DFT-s-OFDM 64 QAM	50@25	20.58	18.08	0.0643
2	15	20	372000	1860.0	DFT-s-OFDM 64 QAM	1@1	20.73	18.23	0.0665
2	15	20	372000	1860.0	DFT-s-OFDM 64 QAM	1@104	20.28	17.78	0.0600
2	15	20	372000	1860.0	DFT-s-OFDM 256 QAM	50@25	18.59	16.09	0.0406
2	15	20	372000	1860.0	DFT-s-OFDM 256 QAM	1@1	18.64	16.14	0.0411
2	15	20	372000	1860.0	DFT-s-OFDM 256 QAM	1@104	18.24	15.74	0.0375
2	15	20	372000	1860.0	CP-OFDM QPSK	53@26	21.42	18.92	0.0780
2	15	20	372000	1860.0	CP-OFDM QPSK	1@1	21.57	19.07	0.0807
2	15	20	372000	1860.0	CP-OFDM QPSK	1@104	21.1	18.6	0.0724
2	15	20	376000	1880.0	DFT-s-OFDM PI/2 BPSK	50@25	22.58	20.08	0.1019
2	15	20	376000	1880.0	DFT-s-OFDM PI/2 BPSK	1@1	22.53	20.03	0.1007
2	15	20	376000	1880.0	DFT-s-OFDM PI/2 BPSK	1@104	22.35	19.85	0.0966
2	15	20	376000	1880.0	DFT-s-OFDM QPSK	50@25	22.55	20.05	0.1012
2	15	20	376000	1880.0	DFT-s-OFDM QPSK	1@1	22.21	19.71	0.0935
2	15	20	376000	1880.0	DFT-s-OFDM QPSK	1@104	22.26	19.76	0.0946
2	15	20	376000	1880.0	DFT-s-OFDM 16 QAM	50@25	21.59	19.09	0.0811

2	15	20	376000	1880.0	DFT-s-OFDM 16 QAM	1@1	21.62	19.12	0.0817
2	15	20	376000	1880.0	DFT-s-OFDM 16 QAM	1@104	21.35	18.85	0.0767
2	15	20	376000	1880.0	DFT-s-OFDM 64 QAM	50@25	20.2	17.7	0.0589
2	15	20	376000	1880.0	DFT-s-OFDM 64 QAM	1@1	20.2	17.7	0.0589
2	15	20	376000	1880.0	DFT-s-OFDM 64 QAM	1@104	19.97	17.47	0.0558
2	15	20	376000	1880.0	DFT-s-OFDM 256 QAM	50@25	18.23	15.73	0.0374
2	15	20	376000	1880.0	DFT-s-OFDM 256 QAM	1@1	18.13	15.63	0.0366
2	15	20	376000	1880.0	DFT-s-OFDM 256 QAM	1@104	17.94	15.44	0.0350
2	15	20	376000	1880.0	CP-OFDM QPSK	53@26	21.01	18.51	0.0710
2	15	20	376000	1880.0	CP-OFDM QPSK	1@1	21.22	18.72	0.0745
2	15	20	376000	1880.0	CP-OFDM QPSK	1@104	20.64	18.14	0.0652
2	15	20	380000	1900.0	DFT-s-OFDM PI/2 BPSK	50@25	22.55	20.05	0.1012
2	15	20	380000	1900.0	DFT-s-OFDM PI/2 BPSK	1@1	22.33	19.83	0.0962
2	15	20	380000	1900.0	DFT-s-OFDM PI/2 BPSK	1@104	22.64	20.14	0.1033
2	15	20	380000	1900.0	DFT-s-OFDM QPSK	50@25	22.6	20.1	0.1023
2	15	20	380000	1900.0	DFT-s-OFDM QPSK	1@1	22.29	19.79	0.0953
2	15	20	380000	1900.0	DFT-s-OFDM QPSK	1@104	22.48	19.98	0.0995
2	15	20	380000	1900.0	DFT-s-OFDM 16 QAM	50@25	21.59	19.09	0.0811
2	15	20	380000	1900.0	DFT-s-OFDM 16 QAM	1@1	21.41	18.91	0.0778
2	15	20	380000	1900.0	DFT-s-OFDM 16 QAM	1@104	21.3	18.8	0.0759
2	15	20	380000	1900.0	DFT-s-OFDM 64 QAM	50@25	20.23	17.73	0.0593
2	15	20	380000	1900.0	DFT-s-OFDM 64 QAM	1@1	19.8	17.3	0.0537
2	15	20	380000	1900.0	DFT-s-OFDM 64 QAM	1@104	19.82	17.32	0.0540
2	15	20	380000	1900.0	DFT-s-OFDM 256 QAM	50@25	18.16	15.66	0.0368



2	15	20	380000	1900.0	DFT-s-OFDM 256 QAM	1@1	17.89	15.39	0.0346
2	15	20	380000	1900.0	DFT-s-OFDM 256 QAM	1@104	18.16	15.66	0.0368
2	15	20	380000	1900.0	CP-OFDM QPSK	53@26	20.99	18.49	0.0706
2	15	20	380000	1900.0	CP-OFDM QPSK	1@1	20.45	17.95	0.0624
2	15	20	380000	1900.0	CP-OFDM QPSK	1@104	20.7	18.2	0.0661

## Frequency Stability

NR Band	SCS (kHz)	Bandwidth (MHz)	Arfcn	Freq (MHz)	Modulation	RB	Deviation (ppm)	Verdict	Environment
2	15	20	376000	1880.0	DFT-s-OFDM QPSK	100@0	0.0027	<b>PASS</b>	NV
2	15	20	376000	1880.0	DFT-s-OFDM QPSK	100@0	0.0065	<b>PASS</b>	LV
2	15	20	376000	1880.0	DFT-s-OFDM QPSK	100@0	0.0021	<b>PASS</b>	HV
2	15	20	376000	1880.0	DFT-s-OFDM QPSK	100@0	0.0041	<b>PASS</b>	-30°C
2	15	20	376000	1880.0	DFT-s-OFDM QPSK	100@0	0.0068	<b>PASS</b>	-20°C
2	15	20	376000	1880.0	DFT-s-OFDM QPSK	100@0	0.0067	<b>PASS</b>	-10°C
2	15	20	376000	1880.0	DFT-s-OFDM QPSK	100@0	0.0037	<b>PASS</b>	0°C
2	15	20	376000	1880.0	DFT-s-OFDM QPSK	100@0	0.0064	<b>PASS</b>	10°C
2	15	20	376000	1880.0	DFT-s-OFDM QPSK	100@0	0.0027	<b>PASS</b>	20°C
2	15	20	376000	1880.0	DFT-s-OFDM QPSK	100@0	0.0052	<b>PASS</b>	30°C
2	15	20	376000	1880.0	DFT-s-OFDM QPSK	100@0	0.0067	<b>PASS</b>	40°C
2	15	20	376000	1880.0	DFT-s-OFDM QPSK	100@0	0.0029	<b>PASS</b>	50°C

## Peak to Average Ratio

NR Band	SCS (kHz)	Bandwidth (MHz)	Arfcn	Freq (MHz)	Modulation	RB	Result (dB)	Limit (dB)	Verdict
2	15	20	372000	1860.0	DFT-s-OFDM PI/2 BPSK	100@0	4.11	13	PASS
2	15	20	372000	1860.0	DFT-s-OFDM PI/2 BPSK	1@0	3.93	13	PASS
2	15	20	372000	1860.0	DFT-s-OFDM QPSK	100@0	5.27	13	PASS
2	15	20	372000	1860.0	DFT-s-OFDM QPSK	1@0	4.65	13	PASS
2	15	20	376000	1880.0	DFT-s-OFDM PI/2 BPSK	100@0	4.1	13	PASS
2	15	20	376000	1880.0	DFT-s-OFDM PI/2 BPSK	1@0	4.28	13	PASS
2	15	20	376000	1880.0	DFT-s-OFDM QPSK	100@0	5.23	13	PASS
2	15	20	376000	1880.0	DFT-s-OFDM QPSK	1@0	4.94	13	PASS
2	15	20	380000	1900.0	DFT-s-OFDM PI/2 BPSK	100@0	4.0	13	PASS
2	15	20	380000	1900.0	DFT-s-OFDM PI/2 BPSK	1@0	4.04	13	PASS
2	15	20	380000	1900.0	DFT-s-OFDM QPSK	100@0	5.09	13	PASS
2	15	20	380000	1900.0	DFT-s-OFDM QPSK	1@0	4.64	13	PASS

N2(20M)\_DFT-s-OFDM\_PI\_2-BPSK\_Outer\_Full\_Low\_CH



N2(20M)\_DFT-s-OFDM\_PI\_2-BPSK\_Edge\_1RB\_Left\_Low\_CH



N2(20M)\_DFT-s-OFDM\_QPSK\_Outer\_Full\_Low\_CH



N2(20M)\_DFT-s-OFDM\_QPSK\_Edge\_1RB\_Left\_Low\_CH



N2(20M)\_DFT-s-OFDM\_PI\_2-BPSK\_Outer\_Full\_Mid\_CH

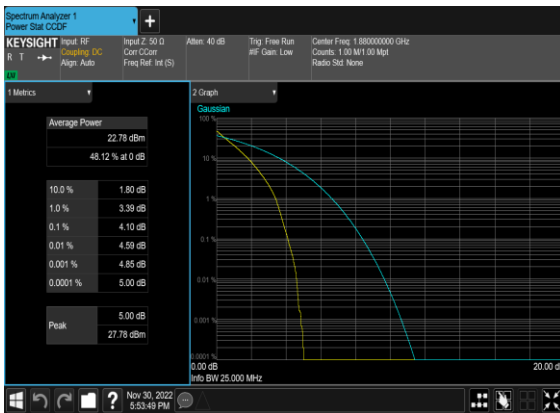

N2(20M)\_DFT-s-OFDM\_PI\_2-BPSK\_Edge\_1RB\_Left\_Mid\_CH



N2(20M)\_DFT-s-OFDM\_QPSK\_Outer\_Full\_Mid\_CH



N2(20M)\_DFT-s-OFDM\_QPSK\_Edge\_1RB\_Left\_Mid\_CH



N2(20M)\_DFT-s-OFDM\_PI\_2-BPSK\_Outer\_Full\_High\_CH



N2(20M)\_DFT-s-OFDM\_PI\_2-BPSK\_Edge\_1RB\_Left\_High\_CH



N2(20M)\_DFT-s-OFDM\_QPSK\_Outer\_Full\_High\_CH



N2(20M)\_DFT-s-OFDM\_QPSK\_Edge\_1RB\_Left\_High\_CH



## Occupied Bandwidth

NR Band	SCS (kHz)	Bandwidth (MHz)	Arfcn	Freq (MHz)	Modulation	RB	OBW (MHz)	26dB OBW (MHz)
2	15	5	376000	1880.0	DFT-s-OFDM PI/2 BPSK	25@0	4.4676	4.768
2	15	5	376000	1880.0	DFT-s-OFDM QPSK	25@0	4.4759	4.879
2	15	5	376000	1880.0	CP-OFDM QPSK	25@0	4.4671	4.863
2	15	5	376000	1880.0	CP-OFDM 16 QAM	25@0	4.459	4.832
2	15	5	376000	1880.0	CP-OFDM 64 QAM	25@0	4.4695	4.859
2	15	5	376000	1880.0	CP-OFDM 256 QAM	25@0	4.4689	4.808
2	15	10	376000	1880.0	DFT-s-OFDM PI/2 BPSK	50@0	8.9143	9.434
2	15	10	376000	1880.0	DFT-s-OFDM QPSK	50@0	8.9257	9.52
2	15	10	376000	1880.0	CP-OFDM QPSK	52@0	9.2742	9.872
2	15	10	376000	1880.0	CP-OFDM 16 QAM	52@0	9.2731	9.881
2	15	10	376000	1880.0	CP-OFDM 64 QAM	52@0	9.2617	9.871
2	15	10	376000	1880.0	CP-OFDM 256 QAM	52@0	9.2755	9.851
2	15	15	376000	1880.0	DFT-s-OFDM PI/2 BPSK	75@0	13.393	14.21
2	15	15	376000	1880.0	DFT-s-OFDM QPSK	75@0	13.388	14.15
2	15	15	376000	1880.0	CP-OFDM QPSK	79@0	14.106	14.79
2	15	15	376000	1880.0	CP-OFDM 16 QAM	79@0	14.111	14.75
2	15	15	376000	1880.0	CP-OFDM 64 QAM	79@0	14.091	14.75
2	15	15	376000	1880.0	CP-OFDM 256 QAM	79@0	14.086	14.81
2	15	20	376000	1880.0	DFT-s-OFDM PI/2 BPSK	100@0	17.852	18.87
2	15	20	376000	1880.0	DFT-s-OFDM QPSK	100@0	17.856	18.91
2	15	20	376000	1880.0	CP-OFDM QPSK	106@0	18.893	19.95
2	15	20	376000	1880.0	CP-OFDM 16 QAM	106@0	18.906	19.93
2	15	20	376000	1880.0	CP-OFDM 64 QAM	106@0	18.899	19.88
2	15	20	376000	1880.0	CP-OFDM 256 QAM	106@0	18.905	19.79

### N2(5M)\_DFT-s-OFDM\_PI\_2- BPSK\_Outer\_Full\_Mid\_CH



### N2(5M)\_DFT-s- OFDM\_QPSK\_Outer\_Full\_Mid\_CH



### N2(5M)\_CP- OFDM\_QPSK\_Outer\_Full\_Mid\_CH



### N2(5M)\_CP-OFDM\_16 QAM\_Outer\_Full\_Mid\_CH



### N2(5M)\_CP-OFDM\_64 QAM\_Outer\_Full\_Mid\_CH

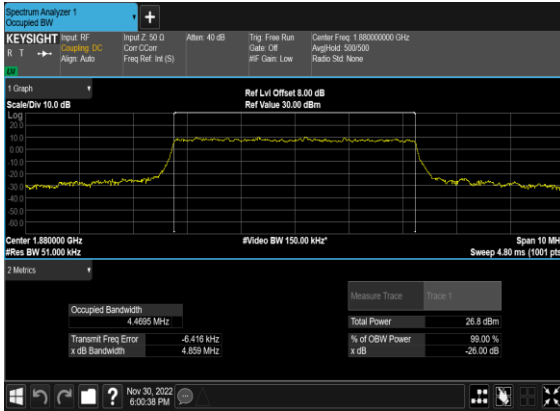

### N2(5M)\_CP-OFDM\_256 QAM\_Outer\_Full\_Mid\_CH

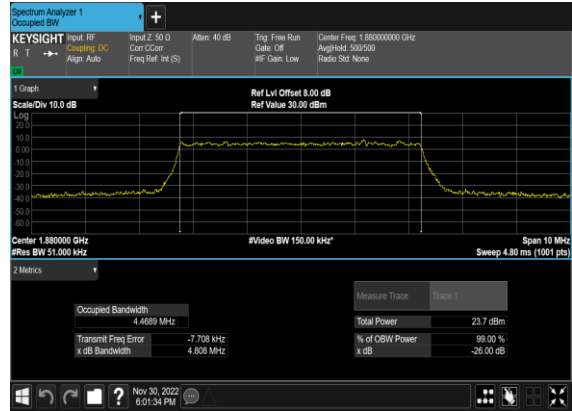

### N2(10M)\_DFT-s-OFDM\_PI\_2- BPSK\_Outer\_Full\_Mid\_CH

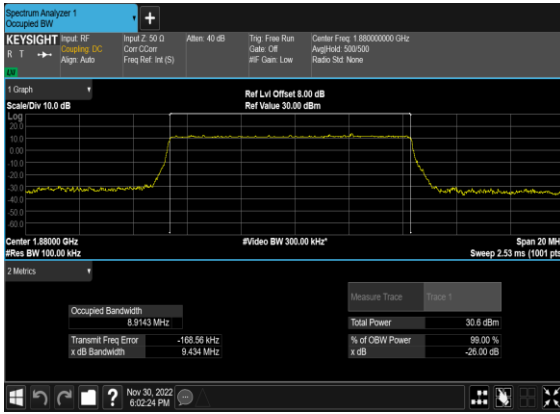

### N2(10M)\_DFT-s- OFDM\_QPSK\_Outer\_Full\_Mid\_CH

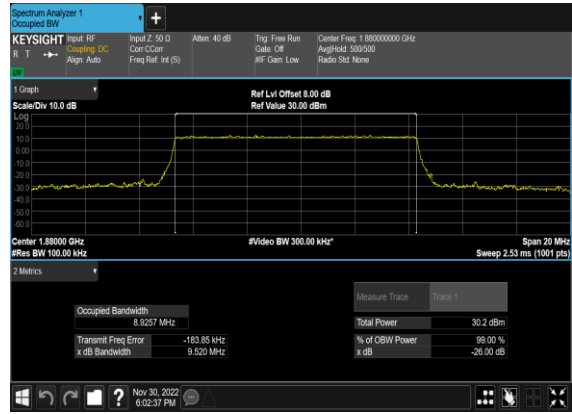

### N2(10M)\_CP- OFDM\_QPSK\_Outer\_Full\_Mid\_CH

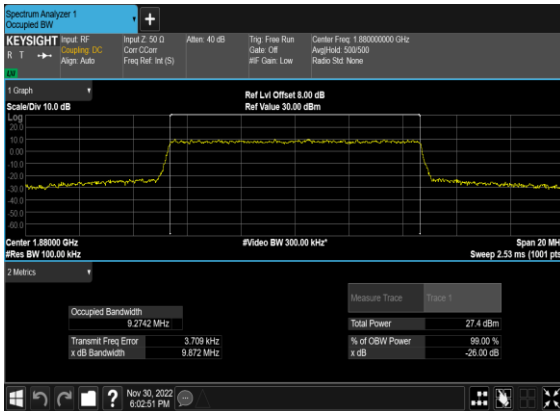

### N2(10M)\_CP-OFDM\_16 QAM\_Outer\_Full\_Mid\_CH

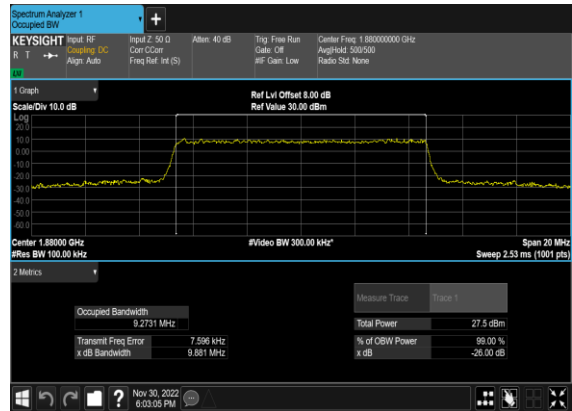



### N2(10M)\_CP-OFDM\_64 QAM\_Outer\_Full\_Mid\_CH

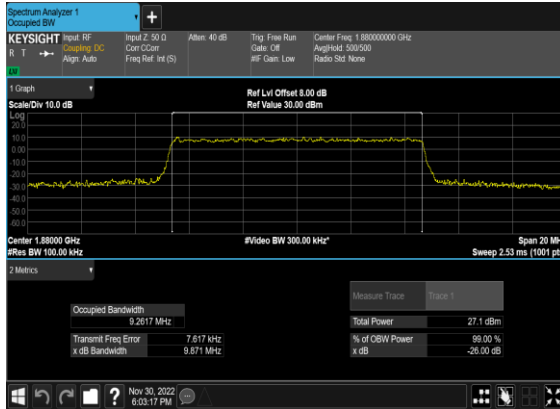

### N2(10M)\_CP-OFDM\_256 QAM\_Outer\_Full\_Mid\_CH

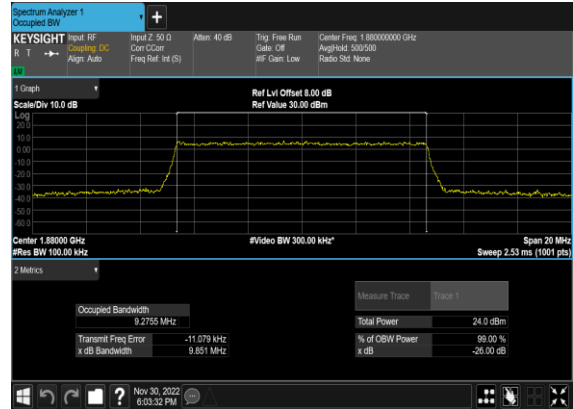

### N2(15M)\_DFT-s-OFDM\_PI\_2- BPSK\_Outer\_Full\_Mid\_CH

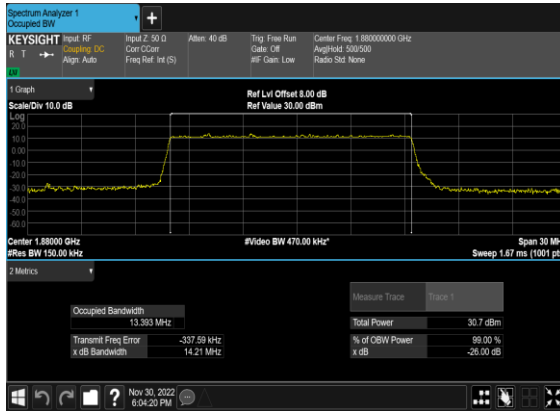

### N2(15M)\_DFT-s- OFDM\_QPSK\_Outer\_Full\_Mid\_CH

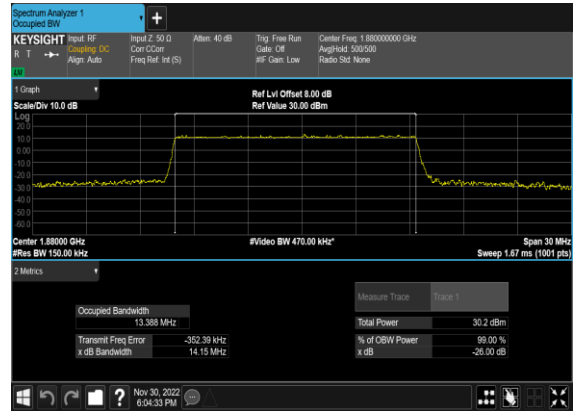

### N2(15M)\_CP- OFDM\_QPSK\_Outer\_Full\_Mid\_CH

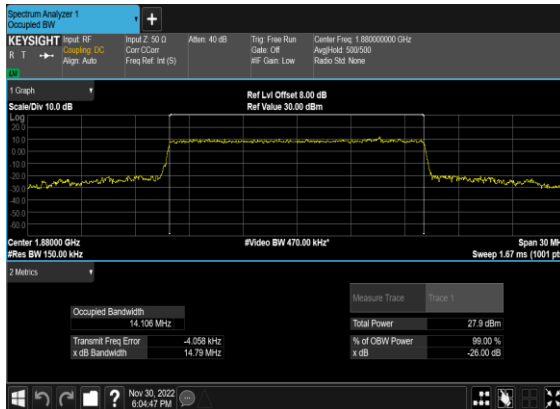

### N2(15M)\_CP-OFDM\_16 QAM\_Outer\_Full\_Mid\_CH

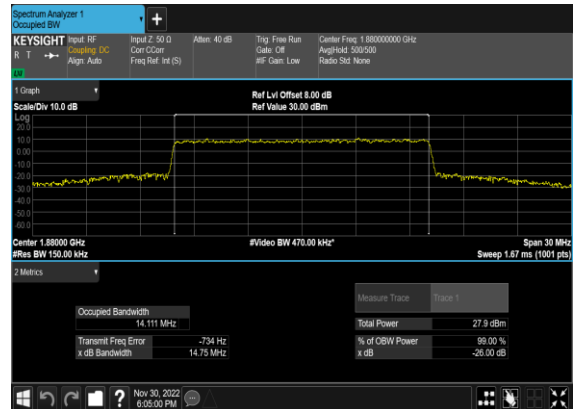

### N2(15M)\_CP-OFDM\_64 QAM\_Outer\_Full\_Mid\_CH

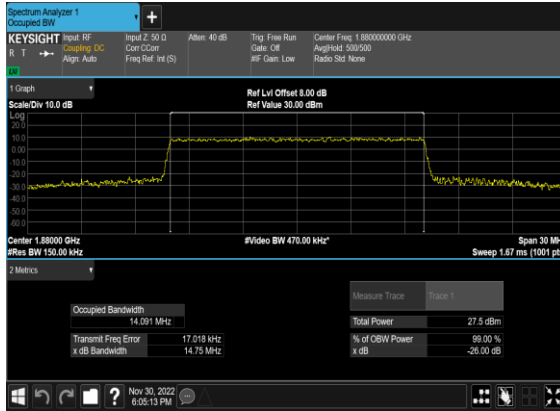

### N2(15M)\_CP-OFDM\_256 QAM\_Outer\_Full\_Mid\_CH

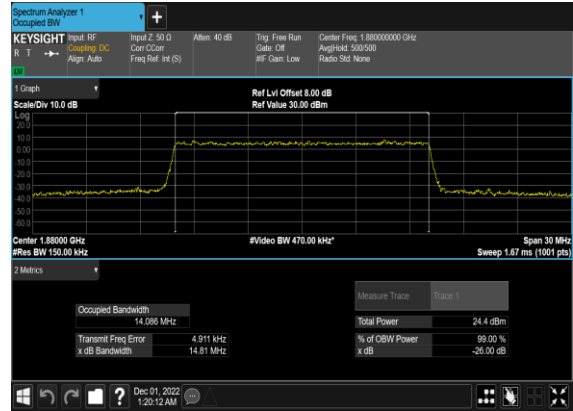

### N2(20M)\_DFT-s-OFDM\_PI\_2- BPSK\_Outer\_Full\_Mid\_CH

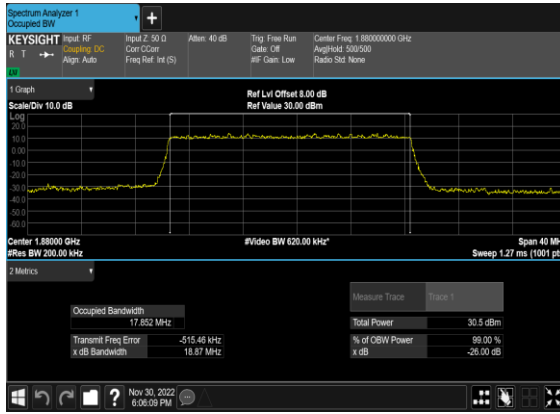

### N2(20M)\_DFT-s- OFDM\_QPSK\_Outer\_Full\_Mid\_CH

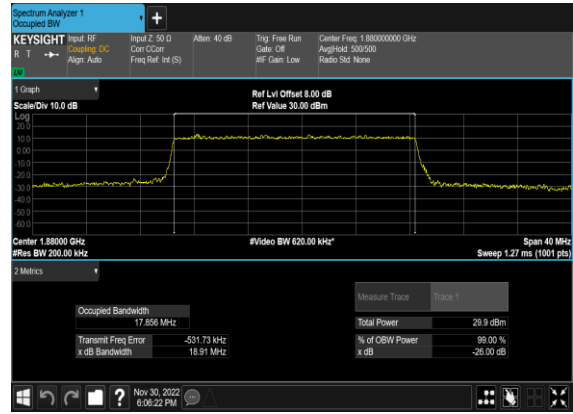

### N2(20M)\_CP- OFDM\_QPSK\_Outer\_Full\_Mid\_CH

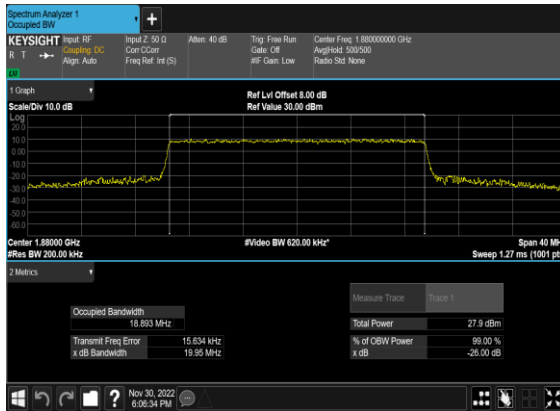

### N2(20M)\_CP-OFDM\_16 QAM\_Outer\_Full\_Mid\_CH



## N2(20M)\_CP-OFDM\_64 QAM\_Outer\_Full\_Mid\_CH

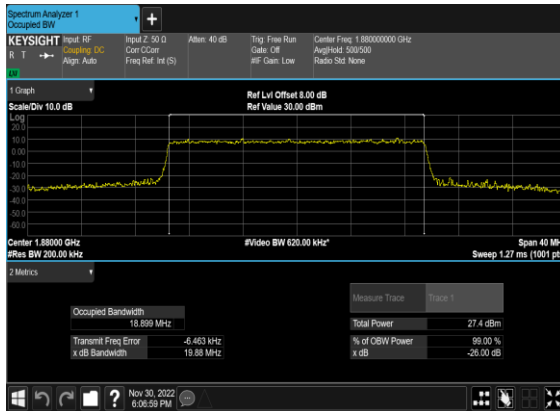

## N2(20M)\_CP-OFDM\_256 QAM\_Outer\_Full\_Mid\_CH

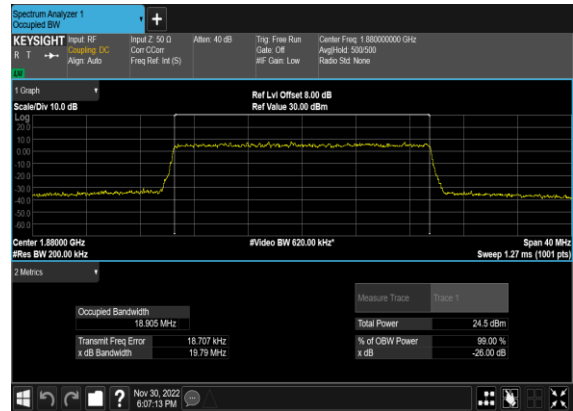

## Conducted Spurious Emissions

NR Band	SCS (kHz)	Bandwidth (MHz)	Arfcn	Freq (MHz)	Modulation	RB	Result	Verdict
2	15	5	370500	1852.5	DFT-s-OFDM BPSK	1@0	see graph	---
2	15	5	370500	1852.5	DFT-s-OFDM BPSK	1@0	see graph	<b>PASS</b>
2	15	5	370500	1852.5	DFT-s-OFDM QPSK	1@0	see graph	---
2	15	5	370500	1852.5	DFT-s-OFDM QPSK	1@0	see graph	<b>PASS</b>
2	15	5	376000	1880.0	DFT-s-OFDM BPSK	1@0	see graph	---
2	15	5	376000	1880.0	DFT-s-OFDM BPSK	1@0	see graph	<b>PASS</b>
2	15	5	376000	1880.0	DFT-s-OFDM QPSK	1@0	see graph	---
2	15	5	376000	1880.0	DFT-s-OFDM QPSK	1@0	see graph	<b>PASS</b>
2	15	5	381500	1907.5	DFT-s-OFDM BPSK	1@0	see graph	---
2	15	5	381500	1907.5	DFT-s-OFDM BPSK	1@0	see graph	<b>PASS</b>
2	15	5	381500	1907.5	DFT-s-OFDM QPSK	1@0	see graph	---
2	15	5	381500	1907.5	DFT-s-OFDM QPSK	1@0	see graph	<b>PASS</b>
2	15	10	371000	1855.0	DFT-s-OFDM BPSK	1@0	see graph	---
2	15	10	371000	1855.0	DFT-s-OFDM BPSK	1@0	see graph	<b>PASS</b>
2	15	10	371000	1855.0	DFT-s-OFDM QPSK	1@0	see graph	---
2	15	10	371000	1855.0	DFT-s-OFDM QPSK	1@0	see graph	<b>PASS</b>
2	15	10	376000	1880.0	DFT-s-OFDM BPSK	1@0	see graph	---
2	15	10	376000	1880.0	DFT-s-OFDM BPSK	1@0	see graph	<b>PASS</b>
2	15	10	376000	1880.0	DFT-s-OFDM QPSK	1@0	see graph	---
2	15	10	376000	1880.0	DFT-s-OFDM QPSK	1@0	see graph	<b>PASS</b>
2	15	10	381000	1905.0	DFT-s-OFDM BPSK	1@0	see graph	---
2	15	10	381000	1905.0	DFT-s-OFDM BPSK	1@0	see graph	<b>PASS</b>

2	15	10	381000	1905.0	DFT-s-OFDM QPSK	1@0	see graph	---
2	15	10	381000	1905.0	DFT-s-OFDM QPSK	1@0	see graph	<b>PASS</b>
2	15	20	372000	1860.0	DFT-s-OFDM BPSK	1@0	see graph	---
2	15	20	372000	1860.0	DFT-s-OFDM BPSK	1@0	see graph	<b>PASS</b>
2	15	20	372000	1860.0	DFT-s-OFDM QPSK	1@0	see graph	---
2	15	20	372000	1860.0	DFT-s-OFDM QPSK	1@0	see graph	<b>PASS</b>
2	15	20	376000	1880.0	DFT-s-OFDM BPSK	1@0	see graph	---
2	15	20	376000	1880.0	DFT-s-OFDM BPSK	1@0	see graph	<b>PASS</b>
2	15	20	376000	1880.0	DFT-s-OFDM QPSK	1@0	see graph	---
2	15	20	376000	1880.0	DFT-s-OFDM QPSK	1@0	see graph	<b>PASS</b>
2	15	20	380000	1900.0	DFT-s-OFDM BPSK	1@0	see graph	---
2	15	20	380000	1900.0	DFT-s-OFDM BPSK	1@0	see graph	<b>PASS</b>
2	15	20	380000	1900.0	DFT-s-OFDM QPSK	1@0	see graph	---
2	15	20	380000	1900.0	DFT-s-OFDM QPSK	1@0	see graph	<b>PASS</b>

### N2(5M)\_DFT-s-OFDM\_BPSK\_Edge\_1RB\_Left\_Low\_CH

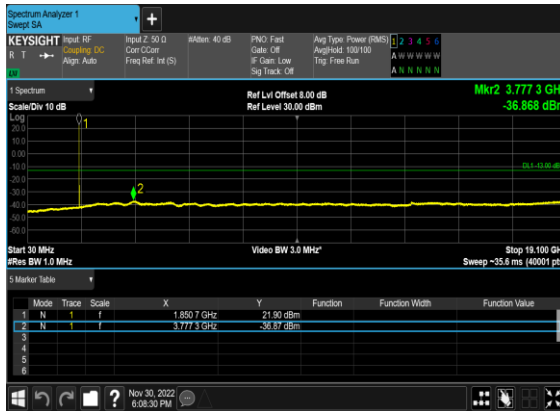

### N2(5M)\_DFT-s-OFDM\_QPSK\_Edge\_1RB\_Left\_Low\_CH

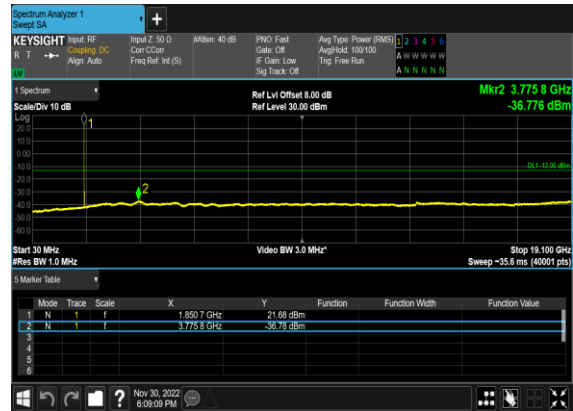

### N2(5M)\_DFT-s-OFDM\_BPSK\_Edge\_1RB\_Left\_Mid\_CH

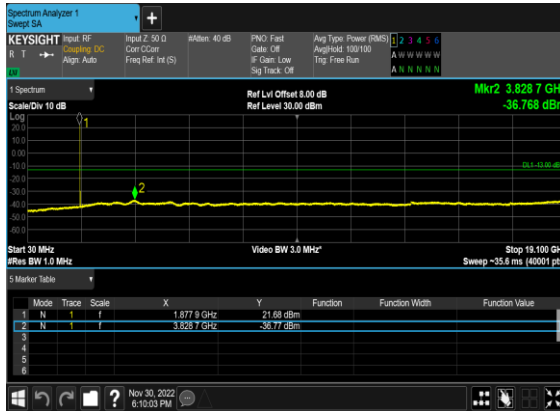

### N2(5M)\_DFT-s-OFDM\_QPSK\_Edge\_1RB\_Left\_Mid\_CH

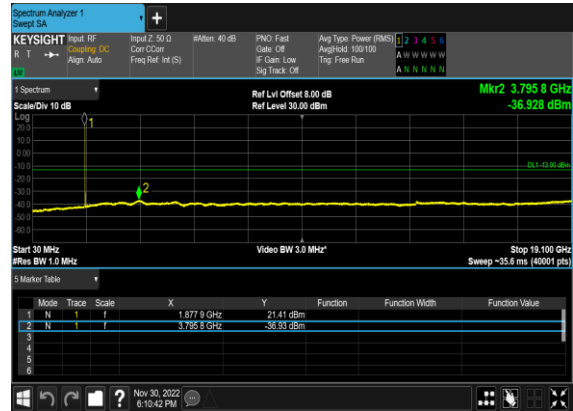

### N2(5M)\_DFT-s-OFDM\_BPSK\_Edge\_1RB\_Left\_High\_CH

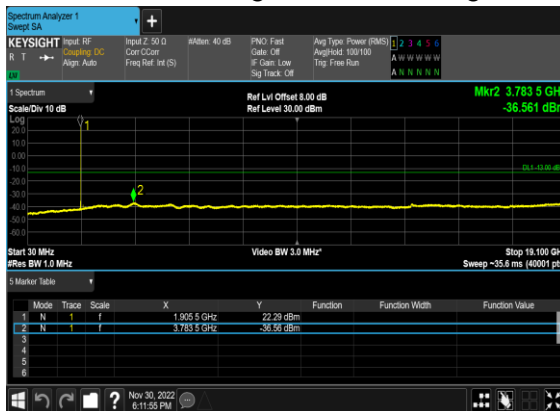

### N2(5M)\_DFT-s-OFDM\_QPSK\_Edge\_1RB\_Left\_High\_CH

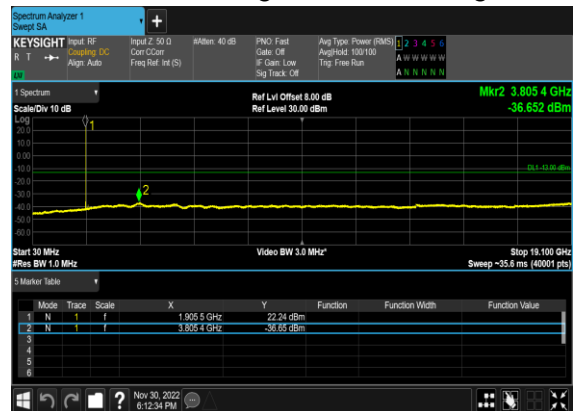

### N2(10M)\_DFT-s-OFDM\_BPSK\_Edge\_1RB\_Left\_Low\_CH

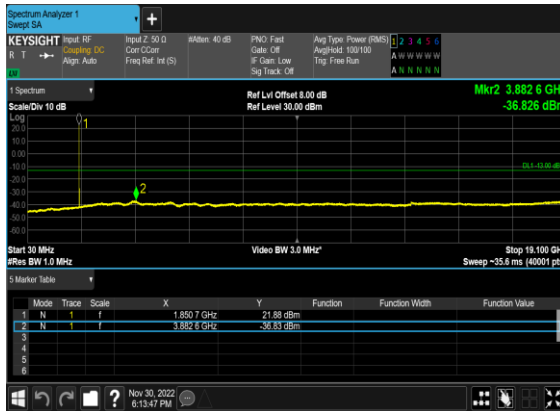

### N2(10M)\_DFT-s-OFDM\_QPSK\_Edge\_1RB\_Left\_Low\_CH

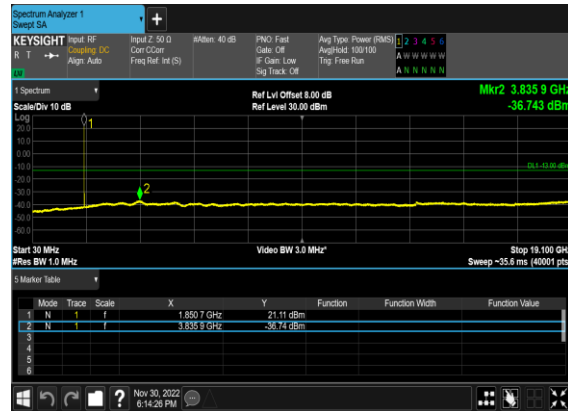

### N2(10M)\_DFT-s-OFDM\_BPSK\_Edge\_1RB\_Left\_Mid\_CH



### N2(10M)\_DFT-s-OFDM\_QPSK\_Edge\_1RB\_Left\_Mid\_CH

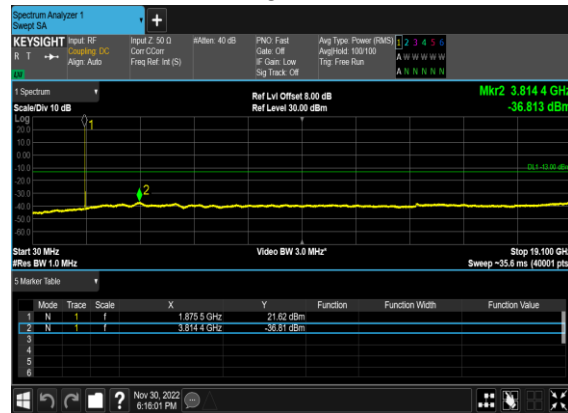

### N2(10M)\_DFT-s-OFDM\_BPSK\_Edge\_1RB\_Left\_High\_CH

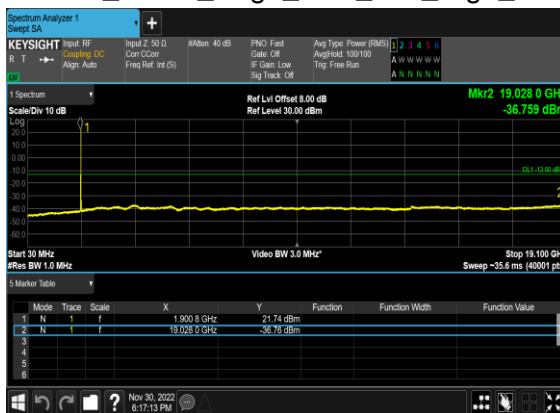

### N2(10M)\_DFT-s-OFDM\_QPSK\_Edge\_1RB\_Left\_High\_CH

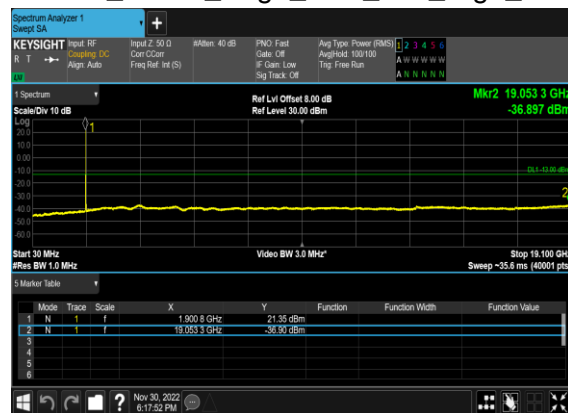

N2(20M)\_DFT-s-OFDM\_BPSK\_Edge\_1RB\_Left\_Low\_CH

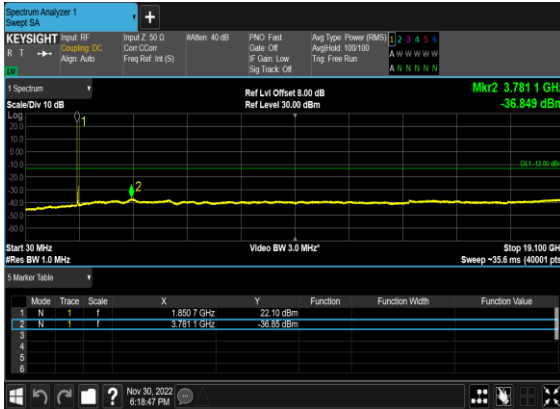

N2(20M)\_DFT-s-OFDM\_QPSK\_Edge\_1RB\_Left\_Low\_CH

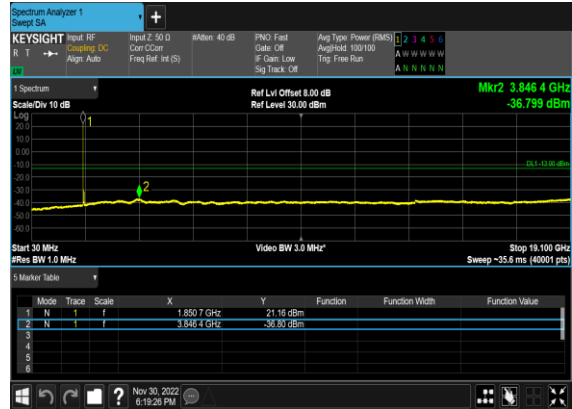

N2(20M)\_DFT-s-OFDM\_BPSK\_Edge\_1RB\_Left\_Mid\_CH

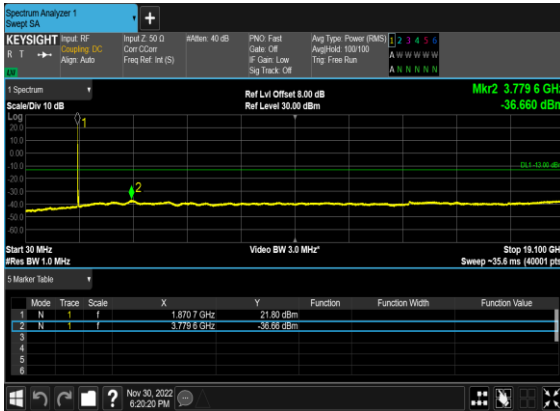

N2(20M)\_DFT-s-OFDM\_QPSK\_Edge\_1RB\_Left\_Mid\_CH

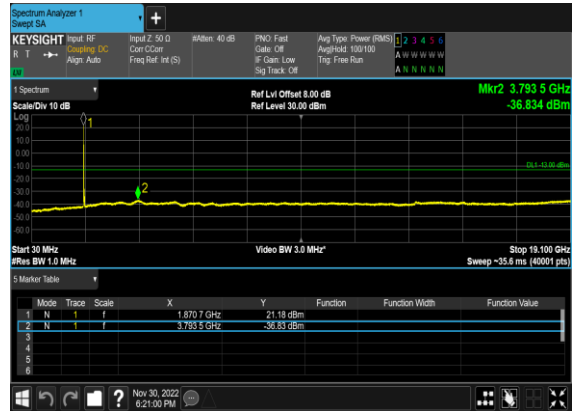

N2(20M)\_DFT-s-OFDM\_BPSK\_Edge\_1RB\_Left\_High\_CH

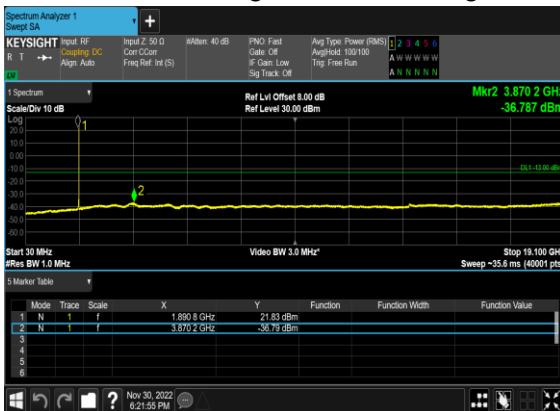

N2(20M)\_DFT-s-OFDM\_QPSK\_Edge\_1RB\_Left\_High\_CH

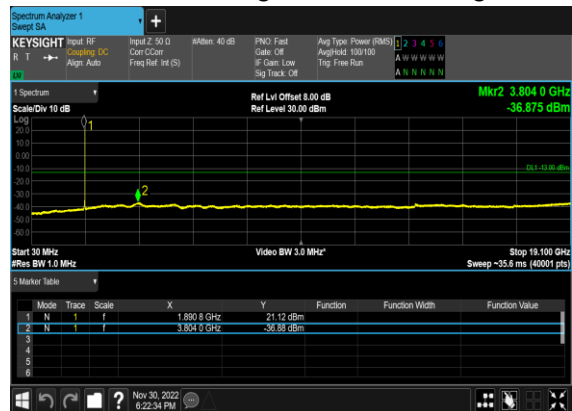



## Conducted Band Edge

NR Band	SCS (kHz)	Bandwidth (MHz)	Arfcn	Freq (MHz)	Modulation	RB	Result	Verdict
2	15	5	370500	1852.5	DFT-s-OFDM BPSK	1@0	see graph	PASS
2	15	5	370500	1852.5	DFT-s-OFDM QPSK	1@0	see graph	PASS
2	15	5	370500	1852.5	DFT-s-OFDM BPSK	25@0	see graph	PASS
2	15	5	370500	1852.5	DFT-s-OFDM QPSK	25@0	see graph	PASS
2	15	5	381500	1907.5	DFT-s-OFDM BPSK	1@24	see graph	PASS
2	15	5	381500	1907.5	DFT-s-OFDM QPSK	1@24	see graph	PASS
2	15	5	381500	1907.5	DFT-s-OFDM BPSK	25@0	see graph	PASS
2	15	5	381500	1907.5	DFT-s-OFDM QPSK	25@0	see graph	PASS
2	15	10	371000	1855.0	DFT-s-OFDM BPSK	1@0	see graph	PASS
2	15	10	371000	1855.0	DFT-s-OFDM QPSK	1@0	see graph	PASS
2	15	10	371000	1855.0	DFT-s-OFDM BPSK	50@0	see graph	PASS
2	15	10	371000	1855.0	DFT-s-OFDM QPSK	50@0	see graph	PASS
2	15	10	381000	1905.0	DFT-s-OFDM BPSK	1@51	see graph	PASS
2	15	10	381000	1905.0	DFT-s-OFDM QPSK	1@51	see graph	PASS
2	15	10	381000	1905.0	DFT-s-OFDM BPSK	50@0	see graph	PASS
2	15	10	381000	1905.0	DFT-s-OFDM QPSK	50@0	see graph	PASS
2	15	20	372000	1860.0	DFT-s-OFDM BPSK	1@0	see graph	PASS
2	15	20	372000	1860.0	DFT-s-OFDM QPSK	1@0	see graph	PASS
2	15	20	372000	1860.0	DFT-s-OFDM BPSK	100@0	see graph	PASS
2	15	20	372000	1860.0	DFT-s-OFDM QPSK	100@0	see graph	PASS
2	15	20	380000	1900.0	DFT-s-OFDM BPSK	1@105	see graph	PASS
2	15	20	380000	1900.0	DFT-s-OFDM QPSK	1@105	see graph	PASS
2	15	20	380000	1900.0	DFT-s-OFDM BPSK	100@0	see graph	PASS
2	15	20	380000	1900.0	DFT-s-OFDM QPSK	100@0	see graph	PASS

### N2(5M)\_DFT-s- OFDM\_BPSK\_Edge\_1RB\_Left\_Low\_CH

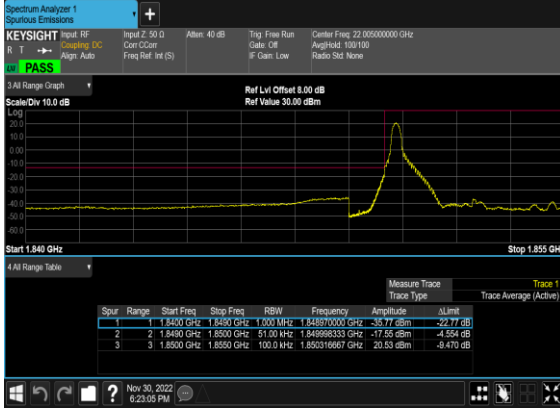

### N2(5M)\_DFT-s- OFDM\_QPSK\_Edge\_1RB\_Left\_Low\_CH

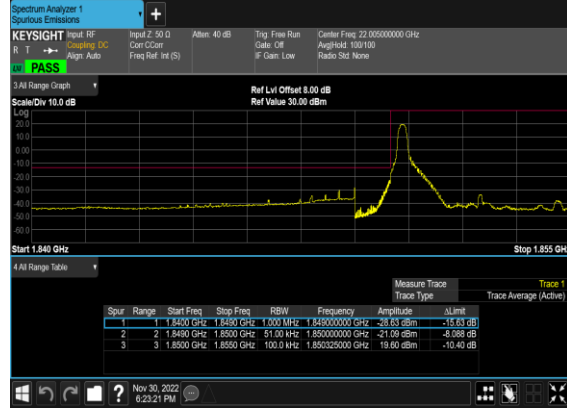

### N2(5M)\_DFT-s- OFDM\_BPSK\_Outer\_Full\_Low\_CH

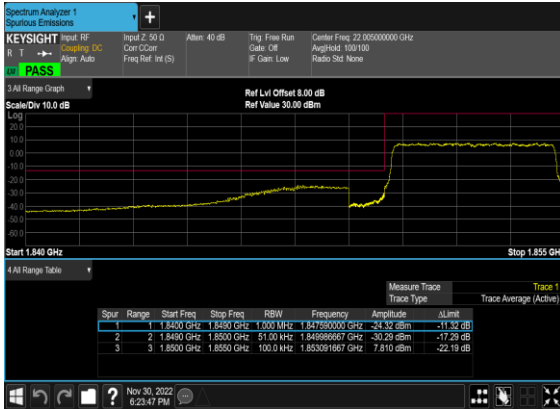

### N2(5M)\_DFT-s- OFDM\_QPSK\_Outer\_Full\_Low\_CH

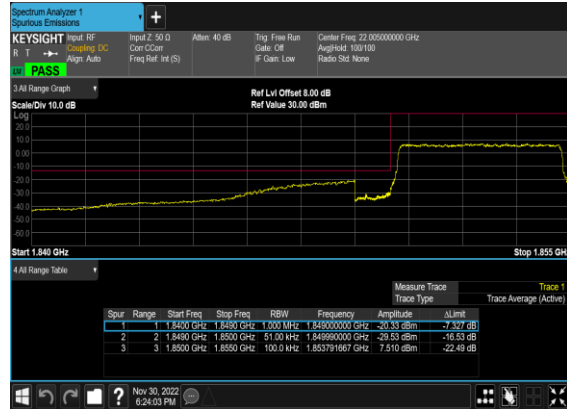

### N2(5M)\_DFT-s- OFDM\_BPSK\_Edge\_1RB\_Right\_High\_CH

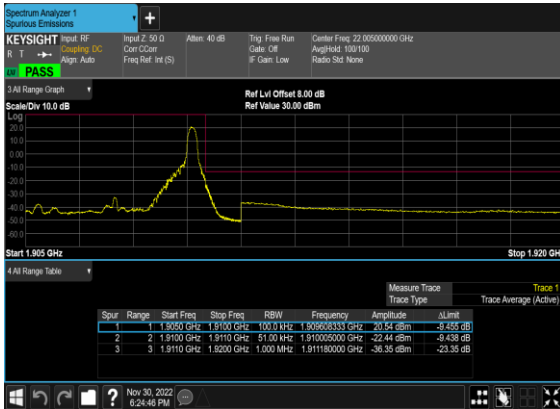

### N2(5M)\_DFT-s- OFDM\_QPSK\_Edge\_1RB\_Right\_High\_CH

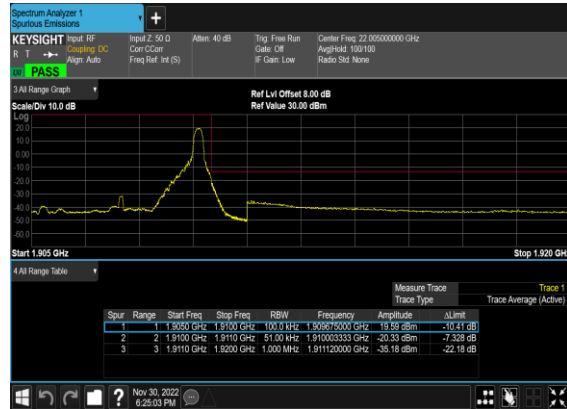

### N2(5M)\_DFT-s-OFDM\_BPSK\_Outer\_Full\_High\_CH

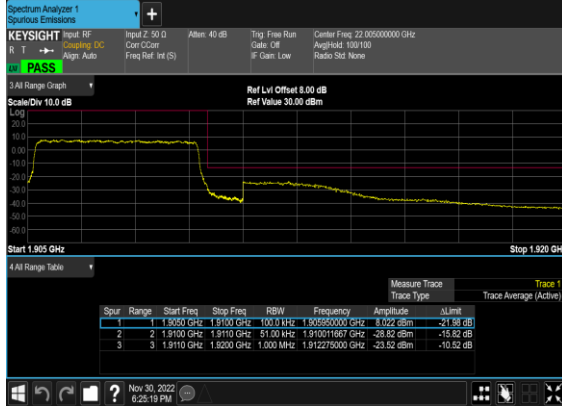

### N2(5M)\_DFT-s-OFDM\_QPSK\_Outer\_Full\_High\_CH

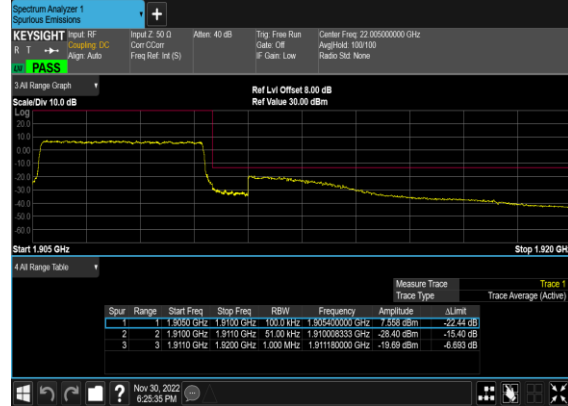

### N2(10M)\_DFT-s-OFDM\_BPSK\_Edge\_1RB\_Left\_Low\_CH

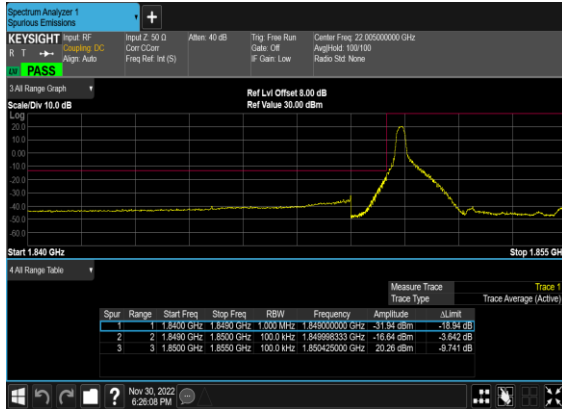

### N2(10M)\_DFT-s-OFDM\_QPSK\_Edge\_1RB\_Left\_Low\_CH

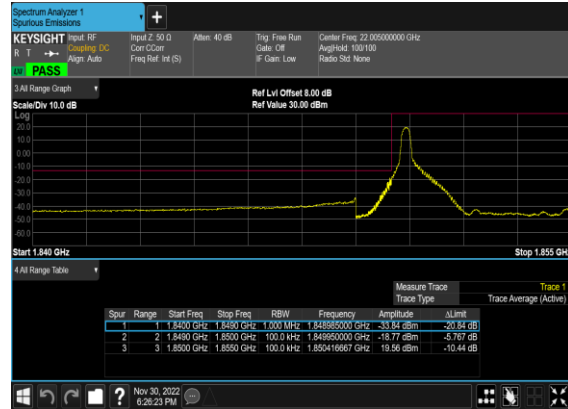

### N2(10M)\_DFT-s-OFDM\_BPSK\_Outer\_Full\_Low\_CH

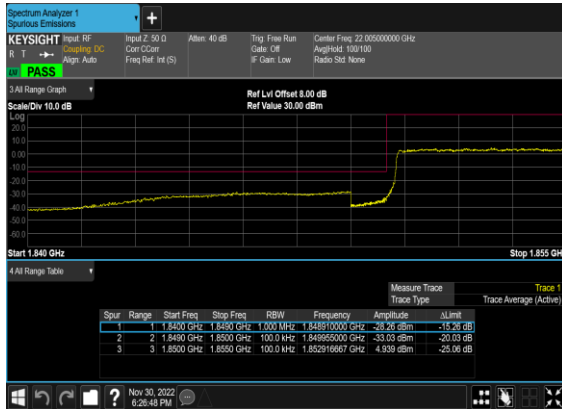

### N2(10M)\_DFT-s-OFDM\_QPSK\_Outer\_Full\_Low\_CH

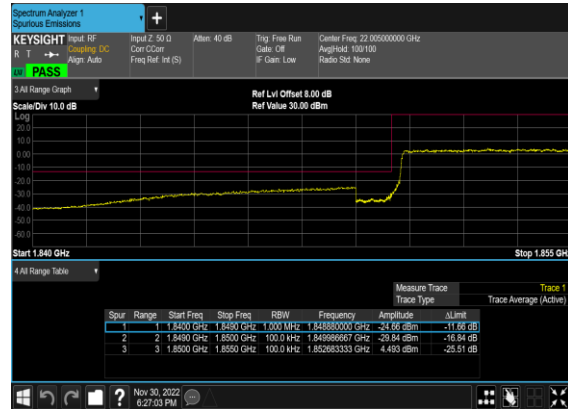

N2(10M)\_DFT-s-OFDM\_BPSK\_Edge\_1RB\_Right\_High\_CH

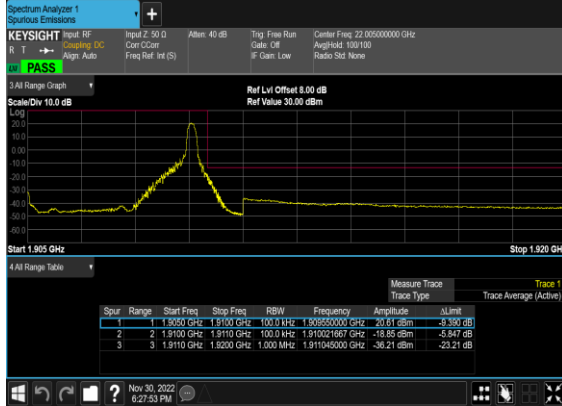

N2(10M)\_DFT-s-OFDM\_QPSK\_Edge\_1RB\_Right\_High\_CH

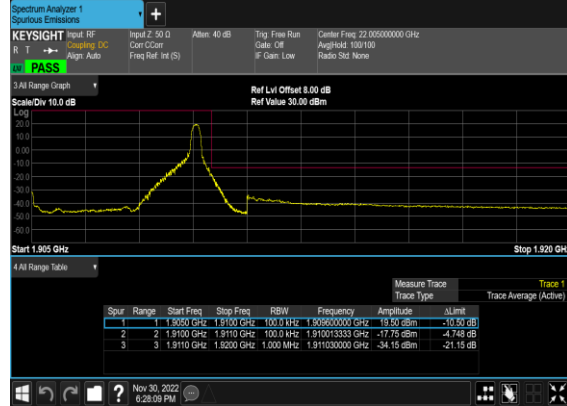

N2(10M)\_DFT-s-OFDM\_BPSK\_Outer\_Full\_High\_CH

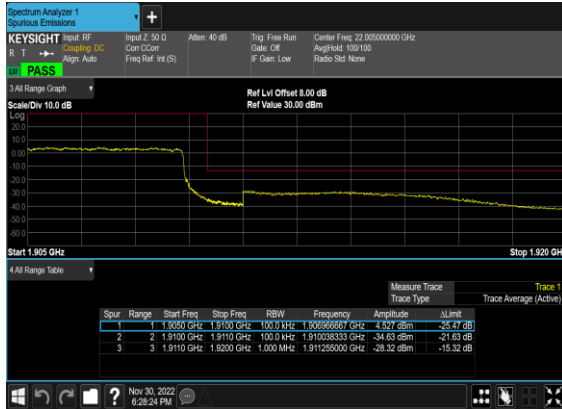

N2(10M)\_DFT-s-OFDM\_QPSK\_Outer\_Full\_High\_CH



N2(20M)\_DFT-s-OFDM\_BPSK\_Edge\_1RB\_Left\_Low\_CH

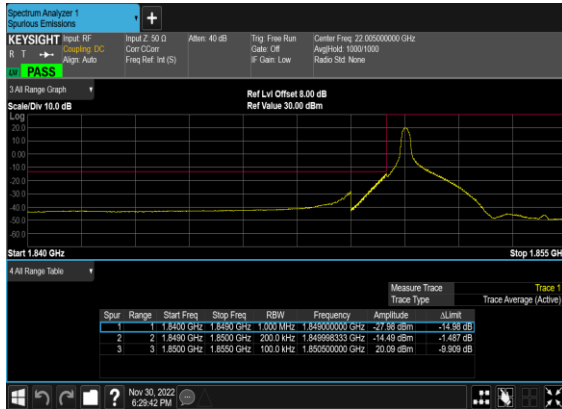

N2(20M)\_DFT-s-OFDM\_QPSK\_Edge\_1RB\_Left\_Low\_CH

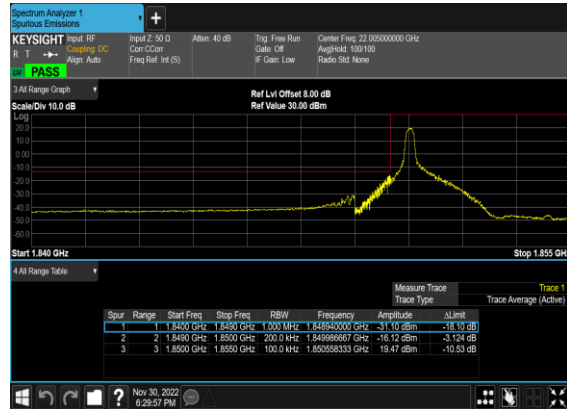

N2(20M)\_DFT-s-  
OFDM\_BPSK\_Outer\_Full\_Low\_CH

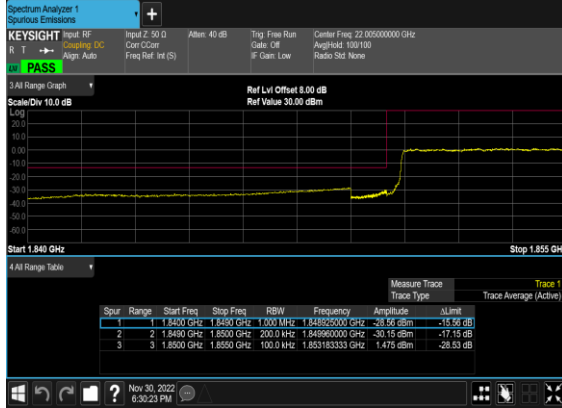

N2(20M)\_DFT-s-  
OFDM\_QPSK\_Outer\_Full\_Low\_CH

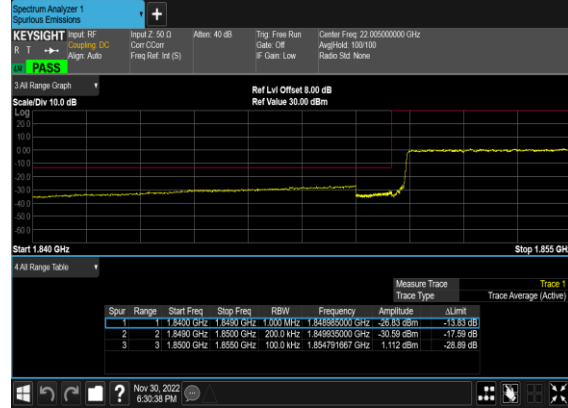

N2(20M)\_DFT-s-  
OFDM\_BPSK\_Edge\_1RB\_Right\_High\_CH

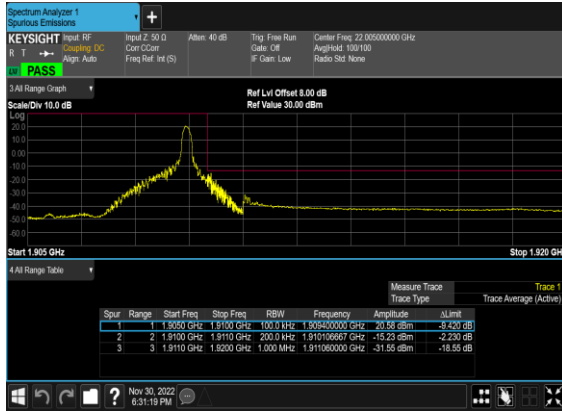

N2(20M)\_DFT-s-  
OFDM\_QPSK\_Edge\_1RB\_Right\_High\_CH

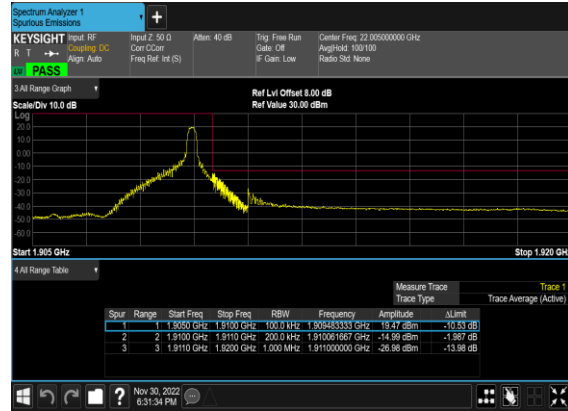

N2(20M)\_DFT-s-  
OFDM\_BPSK\_Outer\_Full\_High\_CH

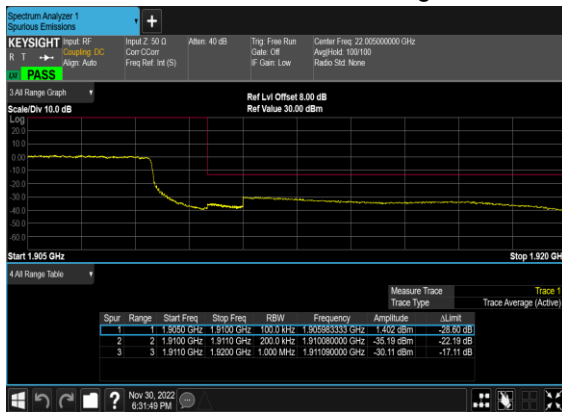

N2(20M)\_DFT-s-  
OFDM\_QPSK\_Outer\_Full\_High\_CH

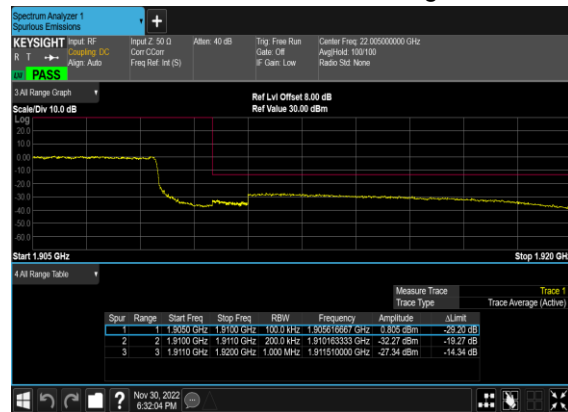

# FR1 N5

## Transmitter Conducted Output Power And ERP, (G<sub>T</sub> - L<sub>C</sub>)=-5.0dB

NR Band	SCS (kHz)	Bandwidth (MHz)	Arfcn	Freq (MHz)	Modulation	RB	Conducted Power(dBm)	ERP(dBm)	ERP(W)
5	15	5	165300	826.5	DFT-s-OFDM QPSK	1@1	22.71	15.56	0.0360
5	15	5	165300	826.5	DFT-s-OFDM 16 QAM	1@1	21.65	14.5	0.0282
5	15	5	167300	836.5	DFT-s-OFDM QPSK	1@1	22.83	15.68	0.0370
5	15	5	167300	836.5	DFT-s-OFDM 16 QAM	1@1	21.93	14.78	0.0301
5	15	5	169300	846.5	DFT-s-OFDM QPSK	1@1	23.24	16.09	0.0406
5	15	5	169300	846.5	DFT-s-OFDM 16 QAM	1@1	22.38	15.23	0.0333
5	15	10	165800	829.0	DFT-s-OFDM QPSK	1@1	23.28	16.13	0.0410
5	15	10	165800	829.0	DFT-s-OFDM 16 QAM	1@1	22.15	15	0.0316
5	15	10	167300	836.5	DFT-s-OFDM QPSK	1@1	23.18	16.03	0.0401
5	15	10	167300	836.5	DFT-s-OFDM 16 QAM	1@1	22.04	14.89	0.0308
5	15	10	168800	844.0	DFT-s-OFDM QPSK	1@1	22.99	15.84	0.0384
5	15	10	168800	844.0	DFT-s-OFDM 16 QAM	1@1	21.85	14.7	0.0295
5	15	15	166300	831.5	DFT-s-OFDM QPSK	1@1	22.54	15.39	0.0346
5	15	15	166300	831.5	DFT-s-OFDM 16 QAM	1@1	21.19	14.04	0.0254
5	15	15	167300	836.5	DFT-s-OFDM QPSK	1@1	22.65	15.5	0.0355
5	15	15	167300	836.5	DFT-s-OFDM 16 QAM	1@1	21.26	14.11	0.0258
5	15	15	168300	841.5	DFT-s-OFDM QPSK	1@1	22.75	15.6	0.0363
5	15	15	168300	841.5	DFT-s-OFDM 16 QAM	1@1	21.44	14.29	0.0269
5	15	20	166800	834.0	DFT-s-OFDM Pi/2 BPSK	50@25	22.97	15.82	0.0382

5	15	20	166800	834.0	DFT-s-OFDM PI/2 BPSK	1@1	22.07	14.92	0.0310
5	15	20	166800	834.0	DFT-s-OFDM PI/2 BPSK	1@104	23.11	15.96	0.0394
5	15	20	166800	834.0	DFT-s-OFDM QPSK	50@25	22.97	15.82	0.0382
5	15	20	166800	834.0	DFT-s-OFDM QPSK	1@1	22.47	15.32	0.0340
5	15	20	166800	834.0	DFT-s-OFDM QPSK	1@104	23.08	15.93	0.0392
5	15	20	166800	834.0	DFT-s-OFDM 16 QAM	50@25	21.53	14.38	0.0274
5	15	20	166800	834.0	DFT-s-OFDM 16 QAM	1@1	21.13	13.98	0.0250
5	15	20	166800	834.0	DFT-s-OFDM 16 QAM	1@104	21.74	14.59	0.0288
5	15	20	166800	834.0	DFT-s-OFDM 64 QAM	50@25	19.98	12.83	0.0192
5	15	20	166800	834.0	DFT-s-OFDM 64 QAM	1@1	19.65	12.5	0.0178
5	15	20	166800	834.0	DFT-s-OFDM 64 QAM	1@104	20.68	13.53	0.0225
5	15	20	166800	834.0	DFT-s-OFDM 256 QAM	50@25	18.01	10.86	0.0122
5	15	20	166800	834.0	DFT-s-OFDM 256 QAM	1@1	17.52	10.37	0.0109
5	15	20	166800	834.0	DFT-s-OFDM 256 QAM	1@104	18.14	10.99	0.0126
5	15	20	166800	834.0	CP-OFDM QPSK	53@26	21.42	14.27	0.0267
5	15	20	166800	834.0	CP-OFDM QPSK	1@1	20.54	13.39	0.0218
5	15	20	166800	834.0	CP-OFDM QPSK	1@104	21.53	14.38	0.0274
5	15	20	167300	836.5	DFT-s-OFDM PI/2 BPSK	50@25	22.54	15.39	0.0346
5	15	20	167300	836.5	DFT-s-OFDM PI/2 BPSK	1@1	22.67	15.52	0.0356
5	15	20	167300	836.5	DFT-s-OFDM PI/2 BPSK	1@104	23.2	16.05	0.0403
5	15	20	167300	836.5	DFT-s-OFDM QPSK	50@25	22.57	15.42	0.0348
5	15	20	167300	836.5	DFT-s-OFDM QPSK	1@1	22.61	15.46	0.0352
5	15	20	167300	836.5	DFT-s-OFDM QPSK	1@104	22.7	15.55	0.0359
5	15	20	167300	836.5	DFT-s-OFDM 16 QAM	50@25	22.03	14.88	0.0308

5	15	20	167300	836.5	DFT-s-OFDM 16 QAM	1@1	21.18	14.03	0.0253
5	15	20	167300	836.5	DFT-s-OFDM 16 QAM	1@104	21.71	14.56	0.0286
5	15	20	167300	836.5	DFT-s-OFDM 64 QAM	50@25	20.48	13.33	0.0215
5	15	20	167300	836.5	DFT-s-OFDM 64 QAM	1@1	20.21	13.06	0.0202
5	15	20	167300	836.5	DFT-s-OFDM 64 QAM	1@104	20.25	13.1	0.0204
5	15	20	167300	836.5	DFT-s-OFDM 256 QAM	50@25	18.47	11.32	0.0136
5	15	20	167300	836.5	DFT-s-OFDM 256 QAM	1@1	17.55	10.4	0.0110
5	15	20	167300	836.5	DFT-s-OFDM 256 QAM	1@104	18.24	11.09	0.0129
5	15	20	167300	836.5	CP-OFDM QPSK	53@26	21.51	14.36	0.0273
5	15	20	167300	836.5	CP-OFDM QPSK	1@1	20.8	13.65	0.0232
5	15	20	167300	836.5	CP-OFDM QPSK	1@104	21.36	14.21	0.0264
5	15	20	167800	839.0	DFT-s-OFDM PI/2 BPSK	50@25	22.58	15.43	0.0349
5	15	20	167800	839.0	DFT-s-OFDM PI/2 BPSK	1@1	22.68	15.53	0.0357
5	15	20	167800	839.0	DFT-s-OFDM PI/2 BPSK	1@104	23.33	16.18	0.0415
5	15	20	167800	839.0	DFT-s-OFDM QPSK	50@25	23.03	15.88	0.0387
5	15	20	167800	839.0	DFT-s-OFDM QPSK	1@1	22.23	15.08	0.0322
5	15	20	167800	839.0	DFT-s-OFDM QPSK	1@104	23.27	16.12	0.0409
5	15	20	167800	839.0	DFT-s-OFDM 16 QAM	50@25	21.62	14.47	0.0280
5	15	20	167800	839.0	DFT-s-OFDM 16 QAM	1@1	21.72	14.57	0.0286
5	15	20	167800	839.0	DFT-s-OFDM 16 QAM	1@104	22.31	15.16	0.0328
5	15	20	167800	839.0	DFT-s-OFDM 64 QAM	50@25	20.53	13.38	0.0218
5	15	20	167800	839.0	DFT-s-OFDM 64 QAM	1@1	20.25	13.1	0.0204
5	15	20	167800	839.0	DFT-s-OFDM 64 QAM	1@104	20.84	13.69	0.0234
5	15	20	167800	839.0	DFT-s-OFDM 256 QAM	50@25	18.54	11.39	0.0138



5	15	20	167800	839.0	DFT-s-OFDM 256 QAM	1@1	18.14	10.99	0.0126
5	15	20	167800	839.0	DFT-s-OFDM 256 QAM	1@104	18.86	11.71	0.0148
5	15	20	167800	839.0	CP-OFDM QPSK	53@26	21.07	13.92	0.0247
5	15	20	167800	839.0	CP-OFDM QPSK	1@1	21.29	14.14	0.0259
5	15	20	167800	839.0	CP-OFDM QPSK	1@104	21.9	14.75	0.0299

## Frequency Stability

NR Band	SCS (kHz)	Bandwidth (MHz)	Arfcn	Freq (MHz)	Modulation	RB	Deviation (ppm)	Verdict	Environment
5	15	20	167300	836.5	DFT-s-OFDM QPSK	100@0	0.0053	<b>PASS</b>	NV
5	15	20	167300	836.5	DFT-s-OFDM QPSK	100@0	0.0063	<b>PASS</b>	LV
5	15	20	167300	836.5	DFT-s-OFDM QPSK	100@0	0.0039	<b>PASS</b>	HV
5	15	20	167300	836.5	DFT-s-OFDM QPSK	100@0	0.0057	<b>PASS</b>	-30°C
5	15	20	167300	836.5	DFT-s-OFDM QPSK	100@0	0.0061	<b>PASS</b>	-20°C
5	15	20	167300	836.5	DFT-s-OFDM QPSK	100@0	0.0050	<b>PASS</b>	-10°C
5	15	20	167300	836.5	DFT-s-OFDM QPSK	100@0	0.0062	<b>PASS</b>	0°C
5	15	20	167300	836.5	DFT-s-OFDM QPSK	100@0	0.0038	<b>PASS</b>	10°C
5	15	20	167300	836.5	DFT-s-OFDM QPSK	100@0	0.0053	<b>PASS</b>	20°C
5	15	20	167300	836.5	DFT-s-OFDM QPSK	100@0	0.0044	<b>PASS</b>	30°C
5	15	20	167300	836.5	DFT-s-OFDM QPSK	100@0	0.0045	<b>PASS</b>	40°C
5	15	20	167300	836.5	DFT-s-OFDM QPSK	100@0	0.0067	<b>PASS</b>	50°C

## Peak to Average Ratio

NR Band	SCS (kHz)	Bandwidth (MHz)	Arfcn	Freq (MHz)	Modulation	RB	Result (dB)	Limit (dB)	Verdict
5	15	20	166800	834.0	DFT-s-OFDM PI/2 BPSK	100@0	4.21	13	PASS
5	15	20	166800	834.0	DFT-s-OFDM PI/2 BPSK	1@0	4.3	13	PASS
5	15	20	166800	834.0	DFT-s-OFDM QPSK	100@0	5.36	13	PASS
5	15	20	166800	834.0	DFT-s-OFDM QPSK	1@0	5.0	13	PASS
5	15	20	167300	836.5	DFT-s-OFDM PI/2 BPSK	100@0	4.35	13	PASS
5	15	20	167300	836.5	DFT-s-OFDM PI/2 BPSK	1@0	4.43	13	PASS
5	15	20	167300	836.5	DFT-s-OFDM QPSK	100@0	5.4	13	PASS
5	15	20	167300	836.5	DFT-s-OFDM QPSK	1@0	5.17	13	PASS
5	15	20	167800	839.0	DFT-s-OFDM PI/2 BPSK	100@0	4.37	13	PASS
5	15	20	167800	839.0	DFT-s-OFDM PI/2 BPSK	1@0	4.41	13	PASS
5	15	20	167800	839.0	DFT-s-OFDM QPSK	100@0	5.52	13	PASS
5	15	20	167800	839.0	DFT-s-OFDM QPSK	1@0	5.13	13	PASS

N5(20M)\_DFT-s-OFDM\_PI\_2-BPSK\_Outer\_Full\_Low\_CH



N5(20M)\_DFT-s-OFDM\_PI\_2-BPSK\_Edge\_1RB\_Left\_Low\_CH



N5(20M)\_DFT-s-OFDM\_QPSK\_Outer\_Full\_Low\_CH



N5(20M)\_DFT-s-OFDM\_QPSK\_Edge\_1RB\_Left\_Low\_CH



N5(20M)\_DFT-s-OFDM\_PI\_2-BPSK\_Outer\_Full\_Mid\_CH

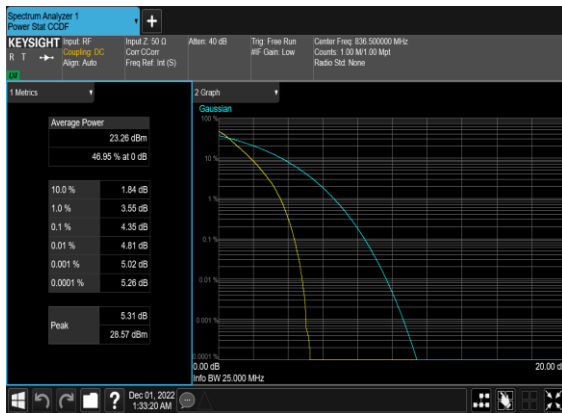

N5(20M)\_DFT-s-OFDM\_PI\_2-BPSK\_Edge\_1RB\_Left\_Mid\_CH

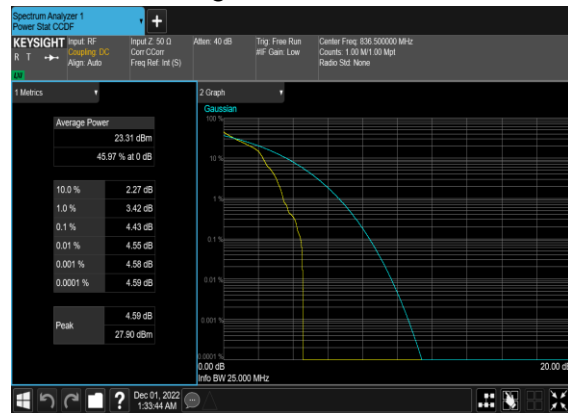

N5(20M)\_DFT-s-OFDM\_QPSK\_Outer\_Full\_Mid\_CH



N5(20M)\_DFT-s-OFDM\_QPSK\_Edge\_1RB\_Left\_Mid\_CH

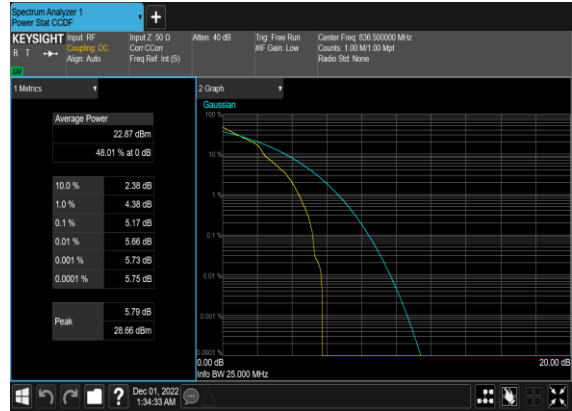

N5(20M)\_DFT-s-OFDM\_PI\_2-BPSK\_Outer\_Full\_High\_CH



N5(20M)\_DFT-s-OFDM\_PI\_2-BPSK\_Edge\_1RB\_Left\_High\_CH



N5(20M)\_DFT-s-OFDM\_QPSK\_Outer\_Full\_High\_CH



N5(20M)\_DFT-s-OFDM\_QPSK\_Edge\_1RB\_Left\_High\_CH



## Occupied Bandwidth

NR Band	SCS (kHz)	Bandwidth (MHz)	Arfcn	Freq (MHz)	Modulation	RB	OBW (MHz)	26dB OBW (MHz)
5	15	5	167300	836.5	DFT-s-OFDM PI/2 BPSK	25@0	4.4505	4.761
5	15	5	167300	836.5	DFT-s-OFDM QPSK	25@0	4.474	4.865
5	15	5	167300	836.5	CP-OFDM QPSK	25@0	4.4665	4.896
5	15	5	167300	836.5	CP-OFDM 16 QAM	25@0	4.4569	4.847
5	15	5	167300	836.5	CP-OFDM 64 QAM	25@0	4.4643	4.857
5	15	5	167300	836.5	CP-OFDM 256 QAM	25@0	4.466	4.812
5	15	10	167300	836.5	DFT-s-OFDM PI/2 BPSK	50@0	8.9189	9.521
5	15	10	167300	836.5	DFT-s-OFDM QPSK	50@0	8.9316	9.493
5	15	10	167300	836.5	CP-OFDM QPSK	52@0	9.2721	9.879
5	15	10	167300	836.5	CP-OFDM 16 QAM	52@0	9.2806	9.866
5	15	10	167300	836.5	CP-OFDM 64 QAM	52@0	9.2618	9.763
5	15	10	167300	836.5	CP-OFDM 256 QAM	52@0	9.2729	9.826
5	15	15	167300	836.5	DFT-s-OFDM PI/2 BPSK	75@0	13.372	14.14
5	15	15	167300	836.5	DFT-s-OFDM QPSK	75@0	13.376	14.05
5	15	15	167300	836.5	CP-OFDM QPSK	79@0	14.082	14.71
5	15	15	167300	836.5	CP-OFDM 16 QAM	79@0	14.08	14.75
5	15	15	167300	836.5	CP-OFDM 64 QAM	79@0	14.07	14.71
5	15	15	167300	836.5	CP-OFDM 256 QAM	79@0	14.081	14.76
5	15	20	167300	836.5	DFT-s-OFDM PI/2 BPSK	100@0	17.828	18.81
5	15	20	167300	836.5	DFT-s-OFDM QPSK	100@0	17.879	18.94
5	15	20	167300	836.5	CP-OFDM QPSK	106@0	18.884	19.83
5	15	20	167300	836.5	CP-OFDM 16 QAM	106@0	18.899	19.79
5	15	20	167300	836.5	CP-OFDM 64 QAM	106@0	18.872	19.74
5	15	20	167300	836.5	CP-OFDM 256 QAM	106@0	18.895	19.88