



FCC RF Test Report

APPLICANT : Bullitt Group
EQUIPMENT : Rugged Smart Phone
BRAND NAME : Motorola
MODEL NAME : BM2S1E
FCC ID : ZL5BM2S1EE
STANDARD : 47 CFR Part 2, 27
CLASSIFICATION : PCS Licensed Transmitter Held to Ear (PCE)
TEST DATE(S) : Nov. 16, 2022 ~ Dec. 11, 2022

We, Sporton International Inc. (Shenzhen), would like to declare that the tested sample has been evaluated in accordance with the procedures given in ANSI C63.26-2015 and shown compliance with the applicable technical standards.

The test results in this report apply exclusively to the tested model / sample. Without written approval of Sporton International Inc. (Shenzhen), the test report shall not be reproduced except in full.

Jason Jia



Approved by: Jason Jia

Sporton International Inc. (ShenZhen)

1/F, 2/F, Bldg 5, Shiling Industrial Zone, Xinwei Village, Xili, Nanshan, Shenzhen, 518055

People's Republic of China



TABLE OF CONTENTS

REVISION HISTORY...3
SUMMARY OF TEST RESULT...4
1 GENERAL DESCRIPTION...5
1.1 Applicant...5
1.2 Manufacturer...5
1.3 Product Feature of Equipment Under Test...5
1.4 Product Specification of Equipment Under Test...5
1.5 Modification of EUT...6
1.6 Maximum EIRP and Emission Designator...6
1.7 Testing Location...8
1.8 Test Software...8
1.9 Applicable Standards...9
2 TEST CONFIGURATION OF EQUIPMENT UNDER TEST...10
2.1 Test Mode...10
2.2 Connection Diagram of Test System...12
2.3 Support Unit used in test configuration and system...12
2.4 Measurement Results Explanation Example...12
2.5 Frequency List of Low/Middle/High Channels...13
3 CONDUCTED TEST ITEMS...15
3.1 Measuring Instruments...15
3.2 Test Setup...15
3.3 Test Result of Conducted Test...15
3.4 Conducted Output Power and EIRP...16
3.5 Peak-to-Average Ratio...17
3.6 Occupied Bandwidth...18
3.7 Conducted Band Edge...19
3.8 Conducted Spurious Emission...20
3.9 Frequency Stability...21
4 RADIATED TEST ITEMS...22
4.1 Measuring Instruments...22
4.2 Test Setup...22
4.3 Test Result of Radiated Test...23
4.4 Radiated Spurious Emission...24
5 LIST OF MEASURING EQUIPMENT...25
6 UNCERTAINTY OF EVALUATION...26
APPENDIX A. TEST RESULTS OF CONDUCTED TEST
APPENDIX B. TEST RESULTS OF RADIATED TEST
APPENDIX C. TEST SETUP PHOTOGRAPHS



SUMMARY OF TEST RESULT

Report Section	FCC Rule	Description	Limit	Result	Remark
3.4	§2.1046	Conducted Output Power	Reporting Only	PASS	-
	§27.50(j)(3)	Equivalent Isotropic Radiated Power (5G NR n77, n78)	EIRP < 1Watt		
3.5	§27.50(j)(4)	Peak-to-Average Ratio	<13 dB	PASS	-
3.6	§2.1049	Occupied Bandwidth	Reporting Only	PASS	-
3.7	§2.1051 §27.53(l)(2)	Conducted Band Edge Measurement (5G NR n77, n78)	< 43+10log10(P[Watts])	PASS	-
3.8	§2.1051 §27.53(l)(2)	Conducted Spurious Emission (5G NR n77, n78)	< 43+10log10(P[Watts])	PASS	-
3.9	§2.1055 §27.54	Frequency Stability Temperature & Voltage	Within Authorized Band	PASS	-
4.4	§2.1053 §27.53(l)(2)	Radiated Spurious Emission (5G NR n77, n78)	< 43+10log ₁₀ (P[Watts])	PASS	Under limit 31.04 dB at 10104.360 MHz

Note: This is the change FCC ID report. Since no changes have been made to this device, all test cases were leveraged from original report (FG2O1410-01D).

Declaration of Conformity:
The test results with all measurement uncertainty excluded are presented in accordance with the regulation limits or requirements declared by manufacturers.
Comments and Explanations:
The declared of product specification for EUT presented in the report are provided by the manufacturer, and the manufacturer takes all the responsibilities for the accuracy of product specification.



1 General Description

1.1 Applicant

Bullitt Group

One Valpy, Valpy Street, Reading, Berkshire, RG1 1AR, United Kingdom

1.2 Manufacturer

Bullitt Mobile Limited

One Valpy, Valpy Street, Reading, Berkshire, RG1 1AR, United Kingdom

1.3 Product Feature of Equipment Under Test

Product Feature	
Equipment	Rugged Smart Phone
Brand Name	Motorola
Model Name	BM2S1E
FCC ID	ZL5BM2S1EE
IMEI Code	Conducted : 351416010000076/351416010002072 Radiation : 351416010000050/351416010002056
EUT Stage	Identical Prototype

1.4 Product Specification of Equipment Under Test

Standards-related Product Specification	
Tx Frequency	5G NR n77: 3700 MHz ~ 3980 MHz 5G NR n78: 3700 MHz ~ 3800 MHz
Rx Frequency	5G NR n77: 3700 MHz ~ 3980 MHz 5G NR n78: 3700 MHz ~ 3800 MHz
Bandwidth	n77/n78(15kHz): 10MHz / 15MHz / 20MHz / 40MHz / 50MHz n77/n78(30kHz): 10MHz / 15MHz / 20MHz / 40MHz / 50MHz / 60MHz / 80MHz / 90MHz / 100MHz
SCS	15kHz, 30kHz
Antenna Type	IFA Antenna
Antenna Gain	<Ant. 2>: n77/n78: -2.1 dBi <Ant. 4>: n77/n78: -2.6 dBi <Ant. 6>: n77/n78: -1.2 dBi <Ant. 11>: n77/n78: -2.5 dBi
Type of Modulation	CP-OFDM: QPSK / 16QAM / 64QAM / 256QAM DFT-s-OFDM: PI/2 BPSK / QPSK / 16QAM / 64QAM / 256QAM

Remark:

1. The device supports HPUE mode for 5G NR n78.
2. The device supports n77/n78(1T4R) SRS resources on Ant.2/4/6/11, only the worst test data of Antenna 6 is showed in the report.
3. 5G NR n77/n78 support SA and NSA mode. According to the maximum power between SA and



NSA mode, SA covers NSA mode for conducted test items.

- 4. The EN-DC mode combination could be referred to the product spec.

1.5 Modification of EUT

No modifications are made to the EUT during all test items.

1.6 Maximum EIRP and Emission Designator

5G NR n77_Ant.6(15kHz)		PI/2 BPSK / QPSK		16QAM / 64QAM / 256QAM	
BW (MHz)	Frequency Range (MHz)	Maximum EIRP(W)	Emission Designator (99%OBW)	Maximum EIRP(W)	Emission Designator (99%OBW)
10	3705.00 ~ 3975.00	0.1439	9M27G7D	0.1202	9M29W7D
15	3707.505 ~ 3972.495	0.1172	14M1G7D	0.1199	14M1W7D
20	3710.01 ~ 3969.99	0.1472	18M9G7D	0.1164	18M9W7D
40	3720.00 ~ 3960.00	0.1175	38M6G7D	0.0991	38M6W7D
50	3725.01 ~ 3954.99	0.1507	48M3G7D	0.1135	48M2W7D

5G NR n77_Ant.6(30kHz)		PI/2 BPSK / QPSK		16QAM / 64QAM / 256QAM	
BW (MHz)	Frequency Range (MHz)	Maximum EIRP(W)	Emission Designator (99%OBW)	Maximum EIRP(W)	Emission Designator (99%OBW)
10	3705.00 ~ 3975.00	0.1387	8M58G7D	0.1159	8M60W7D
15	3707.52 ~ 3972.48	0.1384	13M6G7D	0.1151	13M6W7D
20	3710.01 ~ 3969.99	0.1374	18M2G7D	0.1148	18M2W7D
40	3720.00 ~ 3960.00	0.1288	37M8G7D	0.1042	37M9W7D
50	3725.01 ~ 3954.99	0.1352	47M5G7D	0.1125	47M5W7D
60	3730.02 ~ 3949.98	0.1306	57M9G7D	0.1091	57M9W7D
80	3740.01 ~ 3939.99	0.1265	77M5G7D	0.1054	77M6W7D
90	3745.02 ~ 3934.98	0.1197	87M4G7D	0.1023	87M5W7D
100	3750.00 ~ 3930.00	0.1400	97M2G7D	0.1117	97M4W7D



5G NR n78_Ant.6(15kHz)		PI/2 BPSK / QPSK		16QAM / 64QAM / 256QAM	
BW (MHz)	Frequency Range (MHz)	Maximum EIRP(W)	Emission Designator (99%OBW)	Maximum EIRP(W)	Emission Designator (99%OBW)
10	3705.00 ~ 3795.00	0.2249	9M28G7D	0.1862	9M29W7D
15	3707.505 ~ 3792.495	0.2173	14M1G7D	0.1811	14M1W7D
20	3710.01 ~ 3789.99	0.2084	18M9G7D	0.1714	18M9W7D
40	3720.00 ~ 3780.00	0.1652	38M6G7D	0.1321	38M6W7D
50	3725.01 ~ 3774.99	0.2472	48M3G7D	0.1977	48M2W7D

5G NR n78_Ant.6(30kHz)		PI/2 BPSK / QPSK		16QAM / 64QAM / 256QAM	
BW (MHz)	Frequency Range (MHz)	Maximum EIRP(W)	Emission Designator (99%OBW)	Maximum EIRP(W)	Emission Designator (99%OBW)
10	3705.00 ~ 3795.00	0.2213	8M58G7D	0.2286	8M59W7D
15	3707.52 ~ 3792.48	0.2203	13M6G7D	0.2183	13M6W7D
20	3710.01 ~ 3789.99	0.2280	18M2G7D	0.2037	18M2W7D
40	3720.00 ~ 3780.00	0.1991	37M8G7D	0.1656	37M8W7D
50	3725.01 ~ 3774.99	0.2148	47M4G7D	0.1656	47M6W7D
60	3730.02 ~ 3769.98	0.2065	57M9G7D	0.1710	57M8W7D
80	3740.01 ~ 3759.99	0.1972	77M6G7D	0.1644	77M5W7D
90	3745.02 ~ 3754.98	0.1919	87M4G7D	0.1570	87M5W7D
100	3750.00	0.2455	97M3G7D	0.1986	97M3W7D

Note: All modulations have been tested, only the worst test results of PSK & QAM are shown in the report.



1.7 Testing Location

Sporton International Inc. (ShenZhen) is accredited to ISO/IEC 17025:2017 by American Association for Laboratory Accreditation with Certificate Number 5145.01.

Test Firm	Sporton International Inc. (ShenZhen)		
Test Site Location	1/F, 2/F, Bldg 5, Shiling Industrial Zone, Xinwei Village, Xili, Nanshan, Shenzhen, 518055 People's Republic of China TEL: +86-755-86379589 FAX: +86-755-86379595		
Test Site No.	Sporton Site No.	FCC Designation No.	FCC Test Firm Registration No.
	TH01-SZ	CN1256	421272

Test Firm	Sporton International Inc. (ShenZhen)		
Test Site Location	101, 1st Floor, Block B, Building 1, No. 2, Tengfeng 4th Road, Fenghuang Community, Fuyong Street, Baoan District, Shenzhen City Guangdong Province China 518103 TEL: +86-755-33202398		
Test Site No.	Sporton Site No.	FCC Designation No.	FCC Test Firm Registration No.
	03CH03-SZ	CN1256	421272

1.8 Test Software

Item	Site	Manufacturer	Name	Version
1.	03CH03-SZ	AUDIX	E3	6.2009-8-24



1.9 Applicable Standards

According to the specifications of the manufacturer, the EUT must comply with the requirements of the following standards:

- ♦ 47 CFR Part 2, 27
- ♦ ANSI C63.26-2015
- ♦ FCC KDB 971168 D01 Power Meas License Digital Systems v03r01
- ♦ FCC KDB 412172 D01 Determining ERP and EIRP v01r01

Remark:

All test items were verified and recorded according to the standards and without any deviation during the test.



2 Test Configuration of Equipment Under Test

2.1 Test Mode

Antenna port conducted and radiated test items are performed according to KDB 971168 D01 Power Meas License Digital Systems v03r01 with maximum output power.

For radiated measurement, pre-scanned in three orthogonal panels, X, Y, Z. The worst cases were recorded in this report(X Plane).

The device is investigated from 30MHz to 10 times of fundamental signal for radiated spurious emission test under different RB size/offset and modulations in exploratory test. Subsequently, only the worst case emissions are reported.

Orthogonal Planes of EUT	X Plane	Y Plane	Z Plane
			

SCS: 15kHz

Test Items	5G NR	Bandwidth (MHz)										Modulation					RB #		Test Channel		
		10	15	20	40	50	60	80	90	100	PI/2 BPSK	QPSK	16QAM	64QAM	256 QAM	1	Full	L	M	H	
Max. Output Power	n77	v	v	v	v	v	-	-	-	-	v	v	v	v	v	v	v	v	v	v	
	n78	v	v	v	v	v	-	-	-	-	v	v	v	v	v	v	v	v	v	v	
Peak-to-Average Ratio	n77			v			-	-	-	-	v	v				v	v	v	v	v	
	n78			v			-	-	-	-	v	v				v	v	v	v	v	
26dB and 99% Bandwidth	n77	v	v	v	v	v	-	-	-	-	v	v	v	v	v		v			v	
	n78	v	v	v	v	v	-	-	-	-	v	v	v	v	v		v			v	
Conducted Band Edge	n77	v		v		v	-	-	-	-	v	v				v	v	v		v	
	n78	v		v		v	-	-	-	-	v	v				v	v	v		v	
Conducted Spurious Emission	n77	v		v		v	-	-	-	-	v	v				v		v	v	v	
	n78	v		v		v	-	-	-	-	v	v				v		v	v	v	
Frequency Stability	n77			v			-	-	-	-		v					v			v	
	n78			v			-	-	-	-		v					v			v	
E.I.R.P	n77	v	v	v	v	v	-	-	-	-	v	v	v	v	v	v	v	v	v	v	
	n78	v	v	v	v	v	-	-	-	-	v	v	v	v	v	v	v	v	v	v	
Note	1. The mark "v" means that this configuration is chosen for testing 2. The mark "-" means that this bandwidth is not supported. 3. The device is investigated from 30MHz to 10 times of fundamental signal for radiated spurious emission test under different RB size/offset and modulations in exploratory test. Subsequently, only the worst case emissions are reported. 4. Frequency Stability : Normal Voltage = 3.87V ; Low Voltage =3.6V. ; High Voltage =4.40V																				



SCS: 30kHz

Test Items	5G NR	Bandwidth (MHz)									Modulation					RB #		Test Channel		
		10	15	20	40	50	60	80	90	100	PI/2 BPSK	QPSK	16QAM	64QAM	256 QAM	1	Full	L	M	H
Max. Output Power	n77	v	v	v	v	v	v	v	v	v	v	v	v	v	v	v	v	v	v	v
	n78	v	v	v	v	v	v	v	v	v	v	v	v	v	v	v	v	v	v	v
Peak-to-Average Ratio	n77			v							v	v				v	v	v	v	v
	n78			v							v	v				v	v	v	v	v
26dB and 99% Bandwidth	n77	v	v	v	v	v	v	v	v	v	v	v	v	v	v		v			v
	n78	v	v	v	v	v	v	v	v	v	v	v	v	v	v		v			v
Conducted Band Edge	n77	v				v				v	v	v				v	v	v		v
	n78	v				v				v	v	v				v	v	v		v
Conducted Spurious Emission	n77	v				v				v	v	v				v		v	v	v
	n78	v				v				v	v	v				v		v	v	v
Frequency Stability	n77			v								v					v			v
	n78			v								v					v			v
E.I.R.P	n77	v	v	v	v	v	v	v	v	v	v	v	v	v	v	v	v	v	v	v
	n78	v	v	v	v	v	v	v	v	v	v	v	v	v	v	v	v	v	v	v
Radiated Spurious Emission	n77	Worst Case																		v
	n78	Worst Case																		v
Note	1. The mark "v" means that this configuration is chosen for testing 2. The mark "-" means that this bandwidth is not supported. 3. The device is investigated from 30MHz to 10 times of fundamental signal for radiated spurious emission test under different RB size/offset and modulations in exploratory test. Subsequently, only the worst case emissions are reported. 4. Frequency Stability : Normal Voltage = 3.87V ; Low Voltage =3.6V. ; High Voltage =4.40V																			

2.2 Connection Diagram of Test System

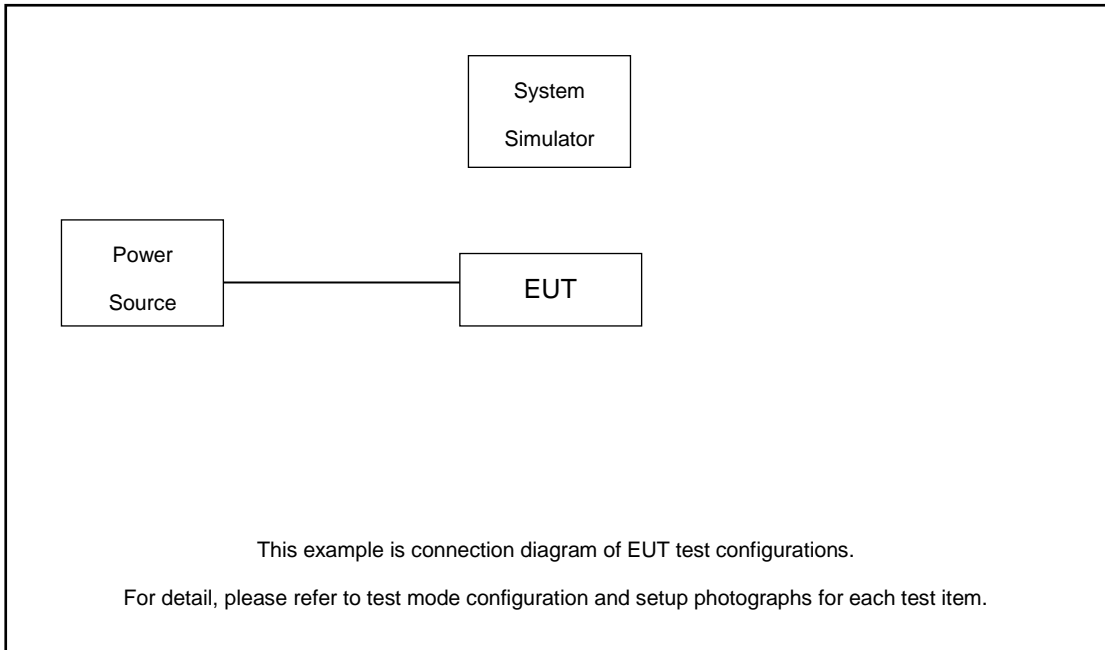

The EUT has been configuration operated in a manner tended to maximize its emission characteristics in a typical application.

2.3 Support Unit used in test configuration and system

Item	Equipment	Trade Name	Model No.	FCC ID	Data Cable	Power Cord
1.	DC Power Supply	GW	GPS-3030D	N/A	N/A	Unshielded, 1.8 m
2.	LTE Base Station	Anritsu	MT8821C	N/A	N/A	Unshielded, 1.8 m
3.	NR Base Station	Anritsu	MT8000A	N/A	N/A	Unshielded, 1.8 m

2.4 Measurement Results Explanation Example

For all conducted test items:

The offset level is set in the spectrum analyzer to compensate the RF cable loss and attenuator factor between EUT conducted output port and spectrum analyzer. With the offset compensation, the spectrum analyzer reading level is exactly the EUT RF output level.

The spectrum analyzer offset is derived from RF cable loss and attenuator factor.

Offset = RF cable loss.

Following shows an offset computation example with cable loss 8.7 dB.

Example :

$$\begin{aligned} \text{Offset(dB)} &= \text{RF cable loss(dB)}. \\ &= 8.7 \text{ (dB)} \end{aligned}$$



2.5 Frequency List of Low/Middle/High Channels

5G n77 Channel and Frequency List (SCS30kHz)				
BW [MHz]	Channel/Frequency(MHz)	Lowest	Middle	Highest
100	Channel	650000	656000	662000
	Frequency	3750	3840	3930
90	Channel	649668	656000	662332
	Frequency	3745.02	3840	3934.98
80	Channel	649334	656000	662666
	Frequency	3740.01	3840	3939.99
60	Channel	648668	656000	663332
	Frequency	3730.02	3840	3949.98
50	Channel	648334	656000	663666
	Frequency	3725.01	3840	3954.99
40	Channel	648000	656000	664000
	Frequency	3720	3840	3960
20	Channel	647334	656000	664666
	Frequency	3710.01	3840	3969.99
15	Channel	647168	656000	664832
	Frequency	3707.52	3840	3972.48
10	Channel	647000	656000	665000
	Frequency	3705	3840	3975

5G n77 Channel and Frequency List (SCS15kHz)				
BW [MHz]	Channel/Frequency(MHz)	Lowest	Middle	Highest
50	Channel	648334	656000	663666
	Frequency	3725.01	3840	3954.99
40	Channel	648000	656000	664000
	Frequency	3720	3840	3960
20	Channel	647334	656000	664666
	Frequency	3710.01	3840	3969.99
15	Channel	647167	656000	664833
	Frequency	3707.505	3840	3972.495
10	Channel	647000	656000	665000
	Frequency	3705	3840	3975



5G n78 Channel and Frequency List(SCS30kHz)				
BW [MHz]	Channel/Frequency(MHz)	Lowest	Middle	Highest
100	Channel	650000		
	Frequency	3750		
90	Channel	649668	650000	650332
	Frequency	3745.02	3750	3754.98
80	Channel	649334	650000	650666
	Frequency	3740.01	3750	3759.99
60	Channel	648668	650000	651332
	Frequency	3730.02	3750	3769.98
50	Channel	648334	650000	651666
	Frequency	3725.01	3750	3774.99
40	Channel	648000	650000	652000
	Frequency	3720	3750	3780
20	Channel	647334	650000	652666
	Frequency	3710.01	3750	3789.99
15	Channel	647168	650000	652832
	Frequency	3707.52	3750	3792.48
10	Channel	647000	650000	653000
	Frequency	3705	3750	3795

5G n78 Channel and Frequency List(SCS15kHz)				
BW [MHz]	Channel/Frequency(MHz)	Lowest	Middle	Highest
50	Channel	648334	650000	651666
	Frequency	3725.01	3750	3774.99
40	Channel	648000	650000	652000
	Frequency	3720	3750	3780
20	Channel	647334	650000	652666
	Frequency	3710.01	3750	3789.99
15	Channel	647167	650000	652833
	Frequency	3707.505	3750	3792.495
10	Channel	647000	650000	653000
	Frequency	3705	3750	3795

3 Conducted Test Items

3.1 Measuring Instruments

See list of measuring instruments of this test report.

3.2 Test Setup

3.2.1 Conducted Output Power

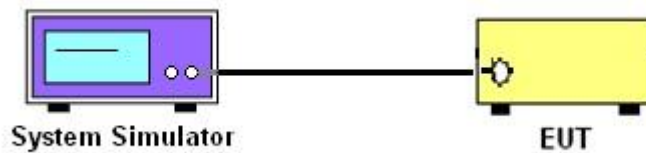

3.2.2 Peak-to-Average Ratio, Occupied Bandwidth, Conducted Band-Edge and Conducted Spurious Emission

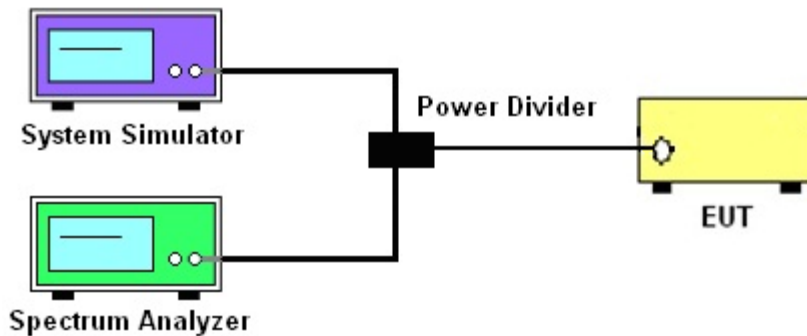

3.2.3 Frequency Stability

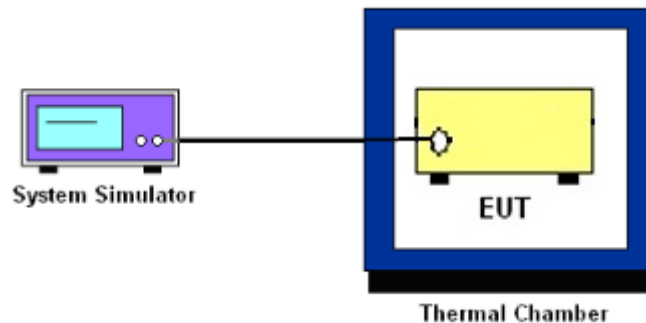

3.3 Test Result of Conducted Test

Please refer to Appendix A.



3.4 Conducted Output Power and EIRP

3.4.1 Description of the Conducted Output Power Measurement and EIRP Measurement

A system simulator was used to establish communication with the EUT. Its parameters were set to force the EUT transmitting at maximum output power. The measured power in the radio frequency on the transmitter output terminals shall be reported.

The EIRP of mobile transmitters must not exceed 1 Watts for 5G NR n77, n78.

According to KDB 412172 D01 Power Approach,

$EIRP = P_T + G_T - L_C$, $ERP = EIRP - 2.15$, where

P_T = transmitter output power in dBm

G_T = gain of the transmitting antenna in dBi

L_C = signal attenuation in the connecting cable between the transmitter and antenna in dB

3.4.2 Test Procedures

1. The testing follows ANSI C63.26 Section 5.2
2. The transmitter output port was connected to the system simulator.
3. Set EUT at maximum power through the system simulator.
4. Select lowest, middle, and highest channels for each band and different modulation.
5. Measure and record the power level from the system simulator.



3.5 Peak-to-Average Ratio

3.5.1 Description of the PAR Measurement

Power Complementary Cumulative Distribution Function (CCDF) curves provide a means for characterizing the power peaks of a digitally modulated signal on a statistical basis. A CCDF curve depicts the probability of the peak signal amplitude exceeding the average power level. Most contemporary measurement instrumentation include the capability to produce CCDF curves for an input signal provided that the instrument's resolution bandwidth can be set wide enough to accommodate the entire input signal bandwidth. In measuring transmissions in this band using an average power technique, the peak-to-average ratio (PAR) of the transmission may not exceed 13 dB.

3.5.2 Test Procedures

1. The testing follows ANSI C63.26 Section 5.2.3.4 (CCDF).
2. The EUT was connected to spectrum and system simulator via a power divider.
3. Set the CCDF (Complementary Cumulative Distribution Function) option in spectrum analyzer.
4. The highest RF powers were measured and recorded the maximum PAPR level associated with a probability of 0.1 %.
5. Record the deviation as Peak to Average Ratio.



3.6 Occupied Bandwidth

3.6.1 Description of Occupied Bandwidth Measurement

The occupied bandwidth is the width of a frequency band such that, below the lower and above the upper frequency limits, the mean powers emitted are each equal to a specified percentage 0.5% of the total mean transmitted power.

The 26 dB emission bandwidth is defined as the frequency range between two points, one above and one below the carrier frequency, at which the spectral density of the emission is attenuated 26 dB below the maximum in-band spectral density of the modulated signal. Spectral density (power per unit bandwidth) is to be measured with a detector of resolution bandwidth equal to approximately 1.0% of the emission bandwidth.

3.6.2 Test Procedures

1. The testing follows ANSI C63.26 Section 5.4
2. The EUT was connected to spectrum analyzer and system simulator via a power divider.
3. The spectrum analyzer center frequency is set to the nominal EUT channel center frequency. The span range for the spectrum analyzer shall be between two and five times the anticipated OBW.
4. The nominal resolution bandwidth (RBW) shall be in the range of 1 to 5 % of the anticipated OBW, and the VBW shall be at least 3 times the RBW.
5. Set the detection mode to peak, and the trace mode to max hold.
6. Determine the reference value: Set the EUT to transmit a modulated signal. Allow the trace to stabilize. Set the spectrum analyzer marker to the highest level of the displayed trace.
(this is the reference value)
7. Determine the “-26 dB down amplitude” as equal to (Reference Value – X).
8. Place two markers, one at the lowest and the other at the highest frequency of the envelope of the spectral display such that each marker is at or slightly below the “-X dB down amplitude” determined in step 6. If a marker is below this “-X dB down amplitude” value it shall be placed as close as possible to this value. The OBW is the positive frequency difference between the two markers.
9. Use the 99 % power bandwidth function of the spectrum analyzer and report the measured bandwidth.



3.7 Conducted Band Edge

3.7.1 Description of Conducted Band Edge Measurement

27.53(l)(2)

For mobile operations in the 3700-3980 MHz band, the conducted power of any emission outside the licensee's authorized bandwidth shall not exceed -13 dBm/MHz. Compliance with this paragraph is based on the use of measurement instrumentation employing a resolution bandwidth of 1 megahertz or greater. However, in the 1 megahertz bands immediately outside and adjacent to the licensee's frequency block, the minimum resolution bandwidth for the measurement shall be either one percent of the emission bandwidth of the fundamental emission of the transmitter or 350 kHz. In the bands between 1 and 5 MHz removed from the licensee's frequency block, the minimum resolution bandwidth for the measurement shall be 500 kHz.

3.7.2 Test Procedures

1. The testing follows ANSI C63.26 section 5.7
2. The EUT was connected to spectrum analyzer and system simulator via a power divider.
3. The band edges of low and high channels for the highest RF powers were measured.
4. Set RBW \geq 1% EBW in the 1MHz band immediately outside and adjacent to the band edge.
5. Beyond the 1 MHz band from the band edge, RBW=1MHz was used or a narrower RBW was used (generally limited to no less than 1% of the OBW) and the measured power was integrated over the full required measurement bandwidth.
6. Set spectrum analyzer with RMS detector.
7. The RF fundamental frequency should be excluded against the limit line in the operating frequency band.
8. Checked that all the results comply with the emission limit line.

Example:

$$\begin{aligned} & \text{The limit line is derived from } 43 + 10\log(P)\text{dB below the transmitter power } P(\text{Watts}) \\ & = P(\text{W}) - [43 + 10\log(P)] \text{ (dB)} \\ & = [30 + 10\log(P)] \text{ (dBm)} - [43 + 10\log(P)] \text{ (dB)} = -13\text{dBm.} \end{aligned}$$

9. When using the integration method, the starting frequency of the integration shall be centered at one-half of the RBW away from the band edge.



3.8 Conducted Spurious Emission

3.8.1 Description of Conducted Spurious Emission Measurement

The power of any emission outside of the authorized operating frequency ranges must be lower than the transmitter power (P) by a factor of at least $43 + 10 \log (P)$ dB.

It is measured by means of a calibrated spectrum analyzer and scanned from 30 MHz up to a frequency including its 10th harmonic.

3.8.2 Test Procedures

1. The testing follows ANSI C63.26 section 5.7
2. The EUT was connected to spectrum analyzer and system simulator via a power divider.
3. The RF output of EUT was connected to the spectrum analyzer by RF cable and attenuator. The path loss was compensated to the results for each measurement.
4. The middle channel for the highest RF power within the transmitting frequency was measured.
5. The conducted spurious emission for the whole frequency range was taken.
6. Make the measurement with the spectrum analyzer's RBW = 1MHz, VBW = 3MHz.
7. Set spectrum analyzer with RMS detector.
8. Taking the record of maximum spurious emission.
9. The RF fundamental frequency should be excluded against the limit line in the operating frequency band.
10. The limit line is derived from $43 + 10\log(P)$ dB below the transmitter power P(Watts)
= P(W)- [43 + 10log(P)] (dB)
= [30 + 10log(P)] (dBm) - [43 + 10log(P)] (dB)
= -13dBm.



3.9 Frequency Stability

3.9.1 Description of Frequency Stability Measurement

The frequency stability shall be measured by variation of ambient temperature and variation of primary supply voltage to ensure that the fundamental emission stays within the authorized frequency block.

3.9.2 Test Procedures for Temperature Variation

1. The testing follows ANSI C63.26 section 5.6.4
2. The EUT was set up in the thermal chamber and connected with the system simulator.
3. With power OFF, the temperature was decreased to -30°C and the EUT was stabilized before testing. Power was applied and the maximum change in frequency was recorded within one minute.
4. With power OFF, the temperature was raised in 10°C step up to 50°C. The EUT was stabilized at each step for at least half an hour. Power was applied and the maximum frequency change was recorded within one minute.

3.9.3 Test Procedures for Voltage Variation

1. The testing follows ANSI C63.26 section 5.6.5
2. The EUT was placed in a temperature chamber at 20±5°C and connected with the system simulator.
3. The power supply voltage to the EUT was varied from 85% to 115% of the nominal value for other than hand carried battery equipment.
4. For hand carried, battery powered equipment, reduce the primary ac or dc supply voltage to the battery operating end point, which shall be specified by the manufacturer.
5. The variation in frequency was measured for the worst case.

4 Radiated Test Items

4.1 Measuring Instruments

See list of measuring instruments of this test report.

4.2 Test Setup

4.2.1 For radiated test below 30MHz

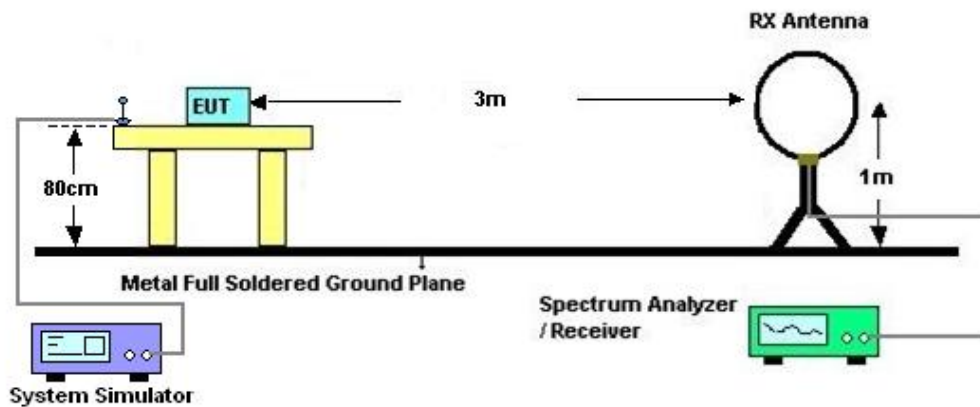

4.2.2 For radiated test from 30MHz to 1GHz

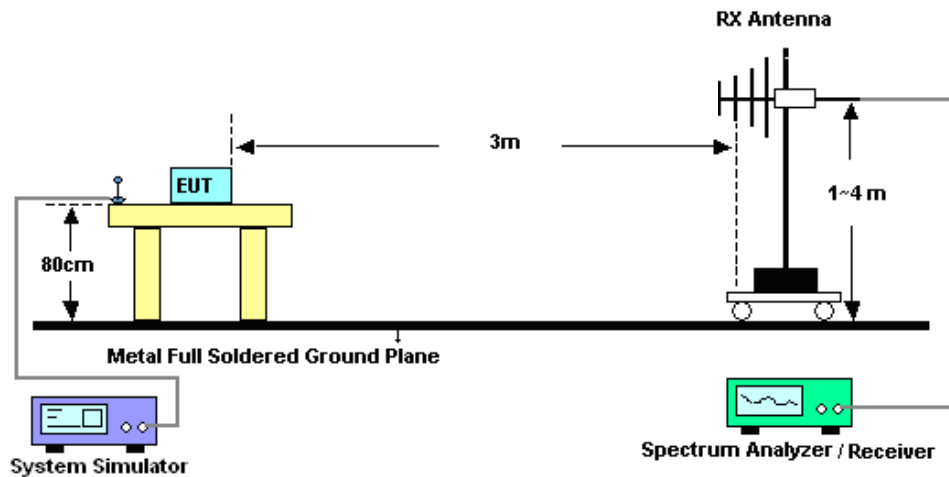

4.2.3 For radiated test above 1GHz

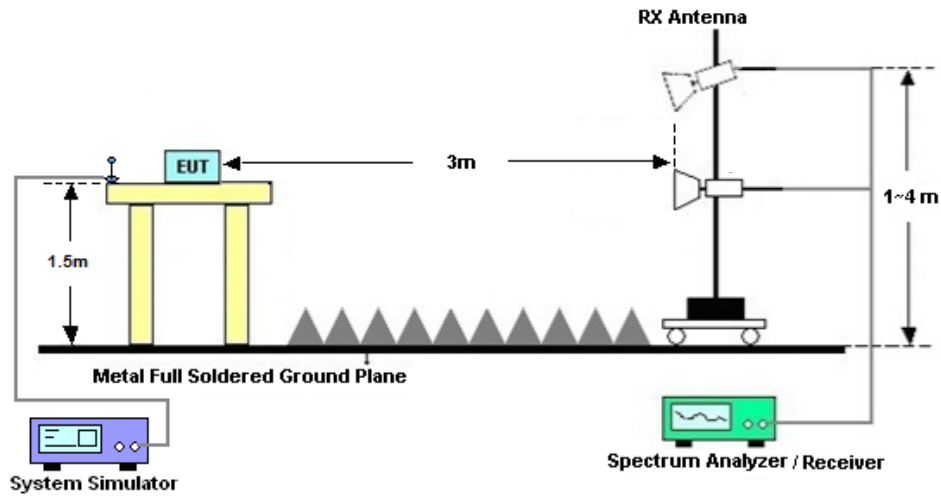

4.3 Test Result of Radiated Test

The low frequency, which started from 9 kHz to 30MHz, was pre-scanned and the result which was 20dB lower than the limit line was not reported.

Please refer to Appendix B.



4.4 Radiated Spurious Emission

4.4.1 Description of Radiated Spurious Emission

The radiated spurious emission was measured by substitution method according to ANSI C63.26. The power of any emission outside of the authorized operating frequency ranges must be attenuated below the transmitter power (P) by a factor of at least $43 + 10 \log (P)$ dB.

4.4.2 Test Procedures

1. The testing follows ANSI C63.26 Section 5.5
2. The EUT was placed on a turntable with 0.8 meter height for frequency below 1GHz and 1.5 meter height for frequency above 1GHz respectively above ground.
3. The EUT was set 3 meters from the receiving antenna mounted on the antenna tower.
4. The table was rotated 360 degrees to determine the position of the highest spurious emission.
5. The height of the receiving antenna is varied between 1m to 4m to search the maximum spurious emission for both horizontal and vertical polarizations.
6. During the measurement, the system simulator parameters were set to force the EUT transmitting at maximum output power.
7. Make the measurement with the spectrum analyzer's RBW = 1MHz, VBW = 3MHz, taking the record of maximum spurious emission.
8. A horn antenna was substituted in place of the EUT and was driven by a signal generator.
9. Tune the output power of signal generator to the same emission level with EUT maximum spurious emission.
10. $EIRP (dBm) = S.G. Power - Tx Cable Loss + Tx Antenna Gain$
11. $ERP (dBm) = EIRP - 2.15$
12. The RF fundamental frequency should be excluded against the limit line in the operating frequency band.

The limit line is derived from $43 + 10\log(P)$ dB below the transmitter power P(Watts)
 $= P(W) - [43 + 10\log(P)] (dB)$
 $= [30 + 10\log(P)] (dBm) - [43 + 10\log(P)] (dB)$
 $= -13dBm.$



5 List of Measuring Equipment

Instrument	Manufacturer	Model No.	Serial No.	Characteristics	Calibration Date	Test Date	Due Date	Remark
Spectrum Analyzer	R&S	FSV40	101078	10Hz~40GHz	Apr. 07, 2022	Nov. 16, 2022~ Dec. 11, 2022	Apr. 06, 2023	Conducted (TH01-SZ)
Power Divider	TOJOIN	PS-2SM-04 265	60.06.020.007 7	0.4GHz~26.5GHz	Dec. 25, 2021	Nov. 16, 2022~ Dec. 11, 2022	Dec. 24, 2022	Conducted (TH01-SZ)
Thermal Chamber	Ten Billion Hongzhangroup	LP-150U	H2014081803	-40~+150°C	Jul. 07, 2022	Nov. 16, 2022~ Dec. 11, 2022	Jul. 06, 2023	Conducted (TH01-SZ)
EXA Spectrum Analyzer	KEYSIGHT	N9010A	MY55150213	10Hz~44GHz	Jul. 07, 2022	Dec. 07, 2022	Jul. 06, 2023	Radiation (03CH03-SZ)
Loop Antenna	R&S	HFH2-Z2	100354	9kHz~30MHz	Jul. 28, 2022	Dec. 07, 2022	Jul. 27, 2024	Radiation (03CH03-SZ)
Bilog Antenna	TeseQ	CBL6112D	35407	30MHz-2GHz	Oct. 19, 2022	Dec. 07, 2022	Oct. 18, 2023	Radiation (03CH03-SZ)
Double Ridge Horn Antenna	ETS-Lindgren	3117	00119436	1GHz~18GHz	Jul. 07, 2022	Dec. 07, 2022	Jul. 06, 2023	Radiation (03CH03-SZ)
HF Amplifier	MITEQ	TTA1840-35 -HG	1871923	18GHz~40GHz	Jul. 07, 2022	Dec. 07, 2022	Jul. 06, 2023	Radiation (03CH03-SZ)
SHF-EHF Horn	com-power	AH-840	101071	18Ghz-40GHz	Apr. 10, 2022	Dec. 07, 2022	Apr. 09, 2023	Radiation (03CH03-SZ)
LF Amplifier	Burgeon	BPA-530	102211	0.01~3000Mhz	Oct. 19, 2022	Dec. 07, 2022	Oct. 18, 2023	Radiation (03CH03-SZ)
HF Amplifier	KEYSIGHT	83017A	MY53270105	0.5GHz~26.5Ghz	Oct. 19, 2022	Dec. 07, 2022	Oct. 18, 2023	Radiation (03CH03-SZ)
AC Power Source	Chroma	61601	616010003043	N/A	Nov. 10, 2022	Dec. 07, 2022	Nov. 09, 2023	Radiation (03CH03-SZ)
Turn Table	Chaintek	T-200	N/A	0~360 degree	NCR	Dec. 07, 2022	NCR	Radiation (03CH03-SZ)
Antenna Mast	Chaintek	MBS-400	N/A	1 m~4 m	NCR	Dec. 07, 2022	NCR	Radiation (03CH03-SZ)

NCR: No Calibration Required



6 Uncertainty of Evaluation

The measurement uncertainties shown below were calculated in accordance with the requirements of ANSI 63.26-2015. All the measurement uncertainty value were shown with a coverage K=2 to indicate 95% level of confidence. The measurement data show herein meets or exceeds the CISPR measurement uncertainty values specified in CISPR 16-4-2 and can be compared directly to specified limit to determine compliance.

Uncertainty of Conducted Measurement

Test Item	Uncertainty
Conducted Power	±1.34 dB
Conducted Emissions	±1.34 dB
Occupied Channel Bandwidth	±0.13 %

Uncertainty of Radiated Emission Measurement (30 MHz ~ 1000 MHz)

Measuring Uncertainty for a Level of Confidence of 95% (U = 2Uc(y))	3.0dB
---	-------

Uncertainty of Radiated Emission Measurement (1000 MHz ~ 18000 MHz)

Measuring Uncertainty for a Level of Confidence of 95% (U = 2Uc(y))	3.6dB
---	-------

Uncertainty of Radiated Emission Measurement (18000 MHz ~ 40000 MHz)

Measuring Uncertainty for a Level of Confidence of 95% (U = 2Uc(y))	3.8dB
---	-------

----- THE END -----



Appendix A. Test Results of Conducted Test

Test Engineer :	Jung Kuo	Temperature :	22~23°C
		Relative Humidity :	40~42%

FR1 N77

Transmitter Conducted Output Power And EIRP, (G_T - L_C)=-1.2dB

NR Band	SCS (kHz)	Bandwidth (MHz)	Arfcn	Freq (MHz)	Modulation	RB	Conducted Power(dBm)	EIRP (dBm)	EIRP (W)
77	15	10	647000	3705	DFT-s-OFDM QPSK	1@1	21.38	20.18	0.1042
77	15	10	647000	3705	DFT-s-OFDM 16 QAM	1@1	20.55	19.35	0.0861
77	15	10	656000	3840	DFT-s-OFDM QPSK	1@1	21.68	20.48	0.1117
77	15	10	656000	3840	DFT-s-OFDM 16 QAM	1@1	20.85	19.65	0.0923
77	15	10	665000	3975	DFT-s-OFDM QPSK	1@1	22.78	21.58	0.1439
77	15	10	665000	3975	DFT-s-OFDM 16 QAM	1@1	22	20.8	0.1202
77	15	15	647167	3707.505	DFT-s-OFDM QPSK	1@1	21.47	20.27	0.1064
77	15	15	647167	3707.505	DFT-s-OFDM 16 QAM	1@1	20.63	19.43	0.0877
77	15	15	656000	3840	DFT-s-OFDM QPSK	1@1	21.89	20.69	0.1172
77	15	15	656000	3840	DFT-s-OFDM 16 QAM	1@1	21.01	19.81	0.0957
77	15	15	664833	3972.495	DFT-s-OFDM QPSK	1@1	21.35	20.15	0.1035
77	15	15	664833	3972.495	DFT-s-OFDM 16 QAM	1@1	21.99	20.79	0.1199
77	15	20	647334	3710.01	DFT-s-OFDM QPSK	1@1	21.45	20.25	0.1059
77	15	20	647334	3710.01	DFT-s-OFDM 16 QAM	1@1	20.59	19.39	0.0869
77	15	20	656000	3840	DFT-s-OFDM QPSK	1@1	21.93	20.73	0.1183
77	15	20	656000	3840	DFT-s-OFDM 16 QAM	1@1	20.86	19.66	0.0925
77	15	20	664666	3969.99	DFT-s-OFDM QPSK	1@1	22.88	21.68	0.1472
77	15	20	664666	3969.99	DFT-s-OFDM 16 QAM	1@1	21.86	20.66	0.1164
77	15	40	648000	3720	DFT-s-OFDM QPSK	1@1	20.95	19.75	0.0944

77	15	40	648000	3720	DFT-s-OFDM 16 QAM	1@1	20.18	18.98	0.0791
77	15	40	656000	3840	DFT-s-OFDM QPSK	1@1	21.9	20.7	0.1175
77	15	40	656000	3840	DFT-s-OFDM 16 QAM	1@1	21.16	19.96	0.0991
77	15	40	664000	3960	DFT-s-OFDM QPSK	1@1	21.6	20.4	0.1096
77	15	40	664000	3960	DFT-s-OFDM 16 QAM	1@1	20.86	19.66	0.0925
77	15	50	648334	3725.01	DFT-s-OFDM PI/2 BPSK	135@67	22.24	21.04	0.1271
77	15	50	648334	3725.01	DFT-s-OFDM PI/2 BPSK	1@1	22.98	21.78	0.1507
77	15	50	648334	3725.01	DFT-s-OFDM PI/2 BPSK	1@268	21.39	20.19	0.1045
77	15	50	648334	3725.01	DFT-s-OFDM QPSK	135@67	22.28	21.08	0.1282
77	15	50	648334	3725.01	DFT-s-OFDM QPSK	1@1	22.6	21.4	0.1380
77	15	50	648334	3725.01	DFT-s-OFDM QPSK	1@268	22.5	21.3	0.1349
77	15	50	648334	3725.01	DFT-s-OFDM 16 QAM	135@67	21.3	20.1	0.1023
77	15	50	648334	3725.01	DFT-s-OFDM 16 QAM	1@1	21.75	20.55	0.1135
77	15	50	648334	3725.01	DFT-s-OFDM 16 QAM	1@268	20.5	19.3	0.0851
77	15	50	648334	3725.01	DFT-s-OFDM 64 QAM	135@67	19.75	18.55	0.0716
77	15	50	648334	3725.01	DFT-s-OFDM 64 QAM	1@1	20.18	18.98	0.0791
77	15	50	648334	3725.01	DFT-s-OFDM 64 QAM	1@268	18.97	17.77	0.0598
77	15	50	648334	3725.01	DFT-s-OFDM 256 QAM	135@67	17.87	16.67	0.0465
77	15	50	648334	3725.01	DFT-s-OFDM 256 QAM	1@1	18.31	17.11	0.0514
77	15	50	648334	3725.01	DFT-s-OFDM 256 QAM	1@268	17.16	15.96	0.0394
77	15	50	648334	3725.01	CP-OFDM QPSK	135@67	20.74	19.54	0.0899
77	15	50	648334	3725.01	CP-OFDM QPSK	1@1	21.19	19.99	0.0998
77	15	50	648334	3725.01	CP-OFDM QPSK	1@268	20.03	18.83	0.0764
77	15	50	656000	3840	DFT-s-OFDM PI/2 BPSK	135@67	21.81	20.61	0.1151

77	15	50	656000	3840	DFT-s-OFDM PI/2 BPSK	1@1	22.02	20.82	0.1208
77	15	50	656000	3840	DFT-s-OFDM PI/2 BPSK	1@268	21.57	20.37	0.1089
77	15	50	656000	3840	DFT-s-OFDM QPSK	135@67	21.84	20.64	0.1159
77	15	50	656000	3840	DFT-s-OFDM QPSK	1@1	21.99	20.79	0.1199
77	15	50	656000	3840	DFT-s-OFDM QPSK	1@268	21.49	20.29	0.1069
77	15	50	656000	3840	DFT-s-OFDM 16 QAM	135@67	20.87	19.67	0.0927
77	15	50	656000	3840	DFT-s-OFDM 16 QAM	1@1	21	19.8	0.0955
77	15	50	656000	3840	DFT-s-OFDM 16 QAM	1@268	20.5	19.3	0.0851
77	15	50	656000	3840	DFT-s-OFDM 64 QAM	135@67	19.35	18.15	0.0653
77	15	50	656000	3840	DFT-s-OFDM 64 QAM	1@1	19.47	18.27	0.0671
77	15	50	656000	3840	DFT-s-OFDM 64 QAM	1@268	19.01	17.81	0.0604
77	15	50	656000	3840	DFT-s-OFDM 256 QAM	135@67	17.45	16.25	0.0422
77	15	50	656000	3840	DFT-s-OFDM 256 QAM	1@1	17.64	16.44	0.0441
77	15	50	656000	3840	DFT-s-OFDM 256 QAM	1@268	17.23	16.03	0.0401
77	15	50	656000	3840	CP-OFDM QPSK	135@67	20.3	19.1	0.0813
77	15	50	656000	3840	CP-OFDM QPSK	1@1	20.62	19.42	0.0875
77	15	50	656000	3840	CP-OFDM QPSK	1@268	20.14	18.94	0.0783
77	15	50	663666	3954.99	DFT-s-OFDM PI/2 BPSK	135@67	21.96	20.76	0.1191
77	15	50	663666	3954.99	DFT-s-OFDM PI/2 BPSK	1@1	21.57	20.37	0.1089
77	15	50	663666	3954.99	DFT-s-OFDM PI/2 BPSK	1@268	21.93	20.73	0.1183
77	15	50	663666	3954.99	DFT-s-OFDM QPSK	135@67	21.99	20.79	0.1199
77	15	50	663666	3954.99	DFT-s-OFDM QPSK	1@1	21.56	20.36	0.1086
77	15	50	663666	3954.99	DFT-s-OFDM QPSK	1@268	21.88	20.68	0.1169
77	15	50	663666	3954.99	DFT-s-OFDM 16 QAM	135@67	21.03	19.83	0.0962

77	15	50	663666	3954.99	DFT-s-OFDM 16 QAM	1@1	20.57	19.37	0.0865
77	15	50	663666	3954.99	DFT-s-OFDM 16 QAM	1@268	20.85	19.65	0.0923
77	15	50	663666	3954.99	DFT-s-OFDM 64 QAM	135@67	19.52	18.32	0.0679
77	15	50	663666	3954.99	DFT-s-OFDM 64 QAM	1@1	19.03	17.83	0.0607
77	15	50	663666	3954.99	DFT-s-OFDM 64 QAM	1@268	19.32	18.12	0.0649
77	15	50	663666	3954.99	DFT-s-OFDM 256 QAM	135@67	17.6	16.4	0.0437
77	15	50	663666	3954.99	DFT-s-OFDM 256 QAM	1@1	17.25	16.05	0.0403
77	15	50	663666	3954.99	DFT-s-OFDM 256 QAM	1@268	17.59	16.39	0.0436
77	15	50	663666	3954.99	CP-OFDM QPSK	135@67	20.44	19.24	0.0839
77	15	50	663666	3954.99	CP-OFDM QPSK	1@1	20.21	19.01	0.0796
77	15	50	663666	3954.99	CP-OFDM QPSK	1@268	20.55	19.35	0.0861

Frequency Stability

NR Band	SCS (kHz)	Bandwidth (MHz)	Arfcn	Freq (MHz)	Modulation	RB	Deviation (ppm)	Verdict	Environment
77	15	20	656000	3840.0	DFT-s-OFDM QPSK	100@0	0.0068	PASS	NV
77	15	20	656000	3840.0	DFT-s-OFDM QPSK	100@0	0.0055	PASS	LV
77	15	20	656000	3840.0	DFT-s-OFDM QPSK	100@0	0.0046	PASS	HV
77	15	20	656000	3840.0	DFT-s-OFDM QPSK	100@0	0.0060	PASS	-30°C
77	15	20	656000	3840.0	DFT-s-OFDM QPSK	100@0	0.0068	PASS	-20°C
77	15	20	656000	3840.0	DFT-s-OFDM QPSK	100@0	0.0066	PASS	-10°C
77	15	20	656000	3840.0	DFT-s-OFDM QPSK	100@0	0.0061	PASS	0°C
77	15	20	656000	3840.0	DFT-s-OFDM QPSK	100@0	0.0023	PASS	10°C
77	15	20	656000	3840.0	DFT-s-OFDM QPSK	100@0	0.0068	PASS	20°C
77	15	20	656000	3840.0	DFT-s-OFDM QPSK	100@0	0.0069	PASS	30°C
77	15	20	656000	3840.0	DFT-s-OFDM QPSK	100@0	0.0027	PASS	40°C
77	15	20	656000	3840.0	DFT-s-OFDM QPSK	100@0	0.0022	PASS	50°C

Peak to Average Ratio

NR Band	SCS (kHz)	Bandwidth (MHz)	Arfcn	Freq (MHz)	Modulation	RB	Result (dB)	Limit (dB)	Verdict
77	15	20	647334	3710.01	DFT-s-OFDM PI/2 BPSK	100@0	3.88	13	PASS
77	15	20	647334	3710.01	DFT-s-OFDM PI/2 BPSK	1@0	4.84	13	PASS
77	15	20	647334	3710.01	DFT-s-OFDM QPSK	100@0	5.26	13	PASS
77	15	20	647334	3710.01	DFT-s-OFDM QPSK	1@0	6.14	13	PASS
77	15	20	656000	3840.0	DFT-s-OFDM PI/2 BPSK	100@0	4.12	13	PASS
77	15	20	656000	3840.0	DFT-s-OFDM PI/2 BPSK	1@0	4.63	13	PASS
77	15	20	656000	3840.0	DFT-s-OFDM QPSK	100@0	5.53	13	PASS
77	15	20	656000	3840.0	DFT-s-OFDM QPSK	1@0	5.85	13	PASS
77	15	20	664666	3969.99	DFT-s-OFDM PI/2 BPSK	100@0	3.89	13	PASS
77	15	20	664666	3969.99	DFT-s-OFDM PI/2 BPSK	1@0	4.31	13	PASS
77	15	20	664666	3969.99	DFT-s-OFDM QPSK	100@0	5.32	13	PASS
77	15	20	664666	3969.99	DFT-s-OFDM QPSK	1@0	5.84	13	PASS

N77(20M)_DFT-s-OFDM_PI_2-BPSK_Outer_Full_Low_CH

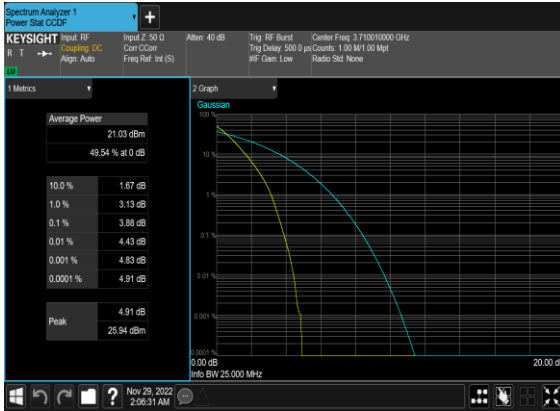

N77(20M)_DFT-s-OFDM_PI_2-BPSK_Edge_1RB_Left_Low_CH



N77(20M)_DFT-s-OFDM_QPSK_Outer_Full_Low_CH

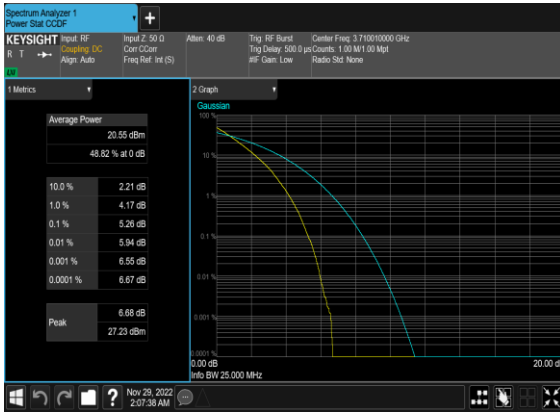

N77(20M)_DFT-s-OFDM_QPSK_Edge_1RB_Left_Low_CH

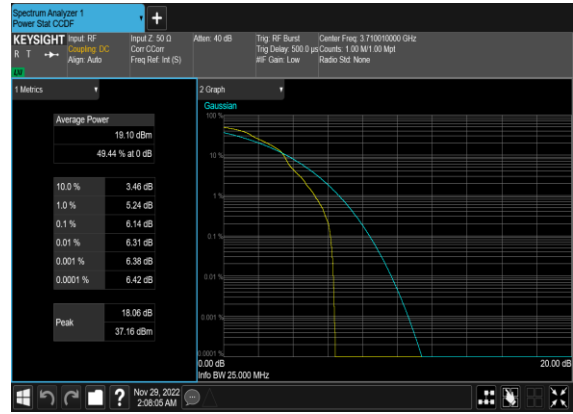

N77(20M)_DFT-s-OFDM_PI_2-BPSK_Outer_Full_Mid_CH

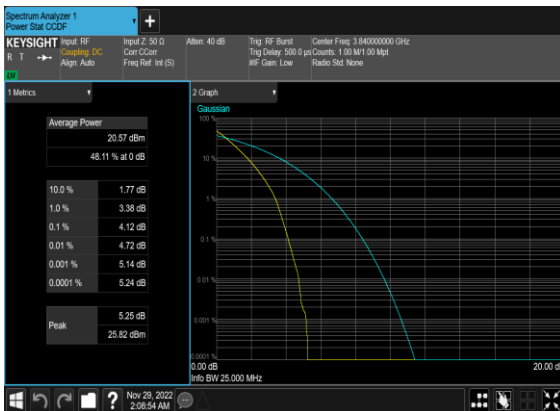

N77(20M)_DFT-s-OFDM_PI_2-BPSK_Edge_1RB_Left_Mid_CH



N77(20M)_DFT-s-OFDM_QPSK_Outer_Full_Mid_CH

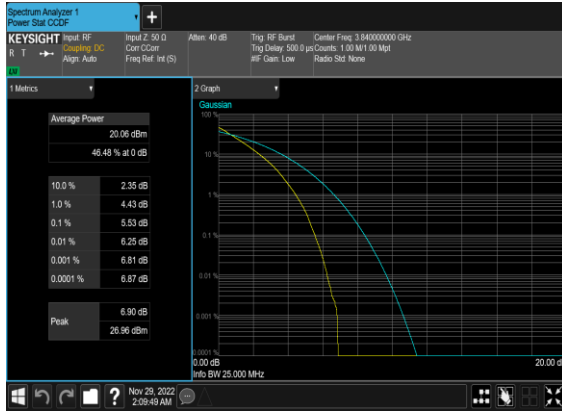

N77(20M)_DFT-s-OFDM_QPSK_Edge_1RB_Left_Mid_CH



N77(20M)_DFT-s-OFDM_PI_2-BPSK_Outer_Full_High_CH

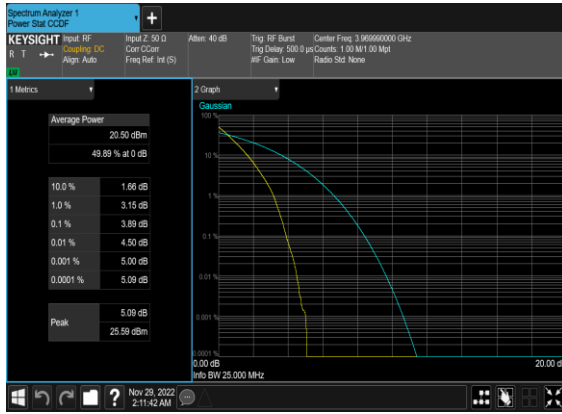

N77(20M)_DFT-s-OFDM_PI_2-BPSK_Edge_1RB_Left_High_CH

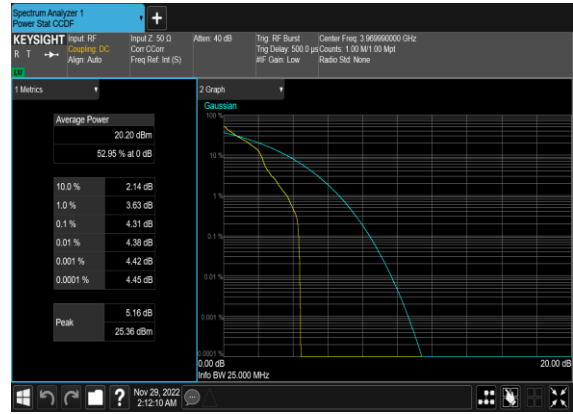

N77(20M)_DFT-s-OFDM_QPSK_Outer_Full_High_CH



N77(20M)_DFT-s-OFDM_QPSK_Edge_1RB_Left_High_CH



Occupied Bandwidth

NR Band	SCS (kHz)	Bandwidth (MHz)	Arfcn	Freq (MHz)	Modulation	RB	OBW (MHz)	26dB OBW (MHz)
77	15	10	656000	3840.0	DFT-s-OFDM PI/2 BPSK	50@0	8.8958	9.607
77	15	10	656000	3840.0	DFT-s-OFDM QPSK	50@0	8.8833	9.489
77	15	10	656000	3840.0	CP-OFDM QPSK	52@0	9.2728	10.19
77	15	10	656000	3840.0	CP-OFDM 16 QAM	52@0	9.2711	9.827
77	15	10	656000	3840.0	CP-OFDM 64 QAM	52@0	9.2795	9.826
77	15	10	656000	3840.0	CP-OFDM 256 QAM	52@0	9.287	9.768
77	15	15	656000	3840.0	DFT-s-OFDM PI/2 BPSK	75@0	13.398	14.2
77	15	15	656000	3840.0	DFT-s-OFDM QPSK	75@0	13.395	14.19
77	15	15	656000	3840.0	CP-OFDM QPSK	79@0	14.08	14.74
77	15	15	656000	3840.0	CP-OFDM 16 QAM	79@0	14.099	14.66
77	15	15	656000	3840.0	CP-OFDM 64 QAM	79@0	14.121	14.7
77	15	15	656000	3840.0	CP-OFDM 256 QAM	79@0	14.096	14.73
77	15	20	656000	3840.0	DFT-s-OFDM PI/2 BPSK	100@0	17.848	18.64
77	15	20	656000	3840.0	DFT-s-OFDM QPSK	100@0	17.858	18.74
77	15	20	656000	3840.0	CP-OFDM QPSK	106@0	18.926	20.25
77	15	20	656000	3840.0	CP-OFDM 16 QAM	106@0	18.911	19.89
77	15	20	656000	3840.0	CP-OFDM 64 QAM	106@0	18.9	19.81
77	15	20	656000	3840.0	CP-OFDM 256 QAM	106@0	18.928	19.91
77	15	40	656000	3840.0	DFT-s-OFDM PI/2 BPSK	216@0	38.557	39.91
77	15	40	656000	3840.0	DFT-s-OFDM QPSK	216@0	38.644	39.99
77	15	40	656000	3840.0	CP-OFDM QPSK	216@0	38.585	39.94
77	15	40	656000	3840.0	CP-OFDM 16 QAM	216@0	38.538	40.29
77	15	40	656000	3840.0	CP-OFDM 64 QAM	216@0	38.547	39.98
77	15	40	656000	3840.0	CP-OFDM 256 QAM	216@0	38.642	40.06

77	15	50	656000	3840.0	DFT-s-OFDM PI/2 BPSK	270@0	48.256	50.05
77	15	50	656000	3840.0	DFT-s-OFDM QPSK	270@0	48.117	49.75
77	15	50	656000	3840.0	CP-OFDM QPSK	270@0	48.188	49.77
77	15	50	656000	3840.0	CP-OFDM 16 QAM	270@0	48.22	49.78
77	15	50	656000	3840.0	CP-OFDM 64 QAM	270@0	48.194	49.93
77	15	50	656000	3840.0	CP-OFDM 256 QAM	270@0	48.199	49.76

N77(10M)_DFT-s-OFDM_PI_2-BPSK_Outer_Full_Mid_CH

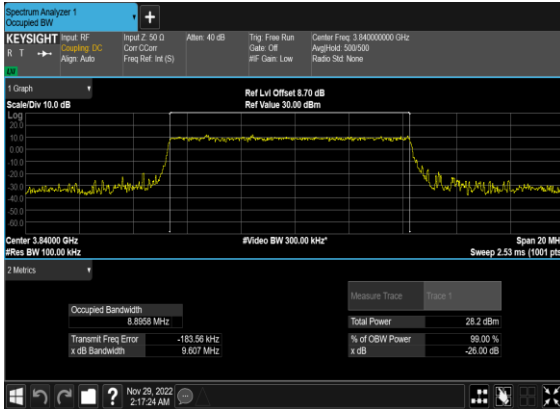

N77(10M)_DFT-s-OFDM_QPSK_Outer_Full_Mid_CH

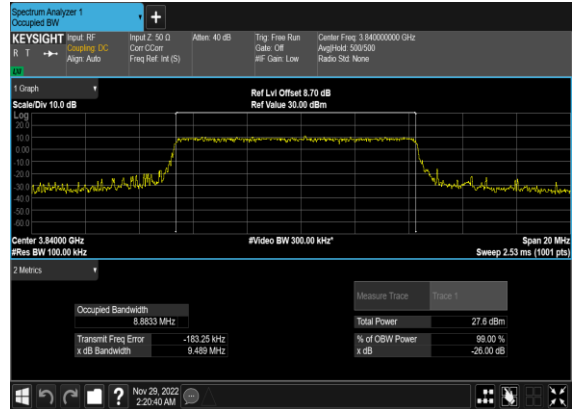

N77(10M)_CP-OFDM_QPSK_Outer_Full_Mid_CH



N77(10M)_CP-OFDM_16QAM_Outer_Full_Mid_CH

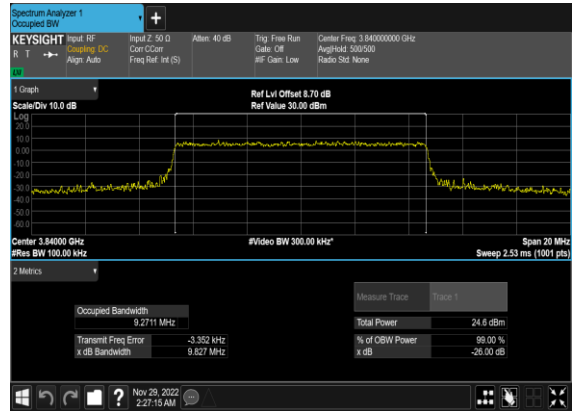

N77(10M)_CP-OFDM_64QAM_Outer_Full_Mid_CH

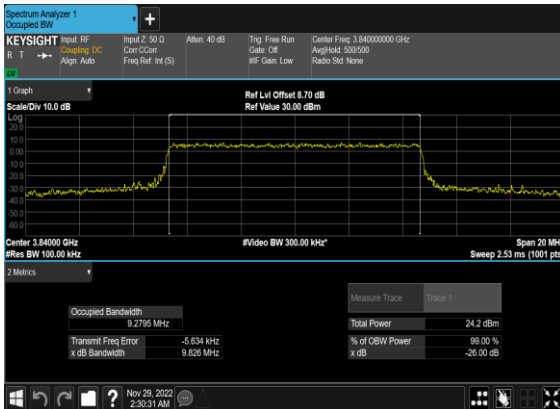

N77(10M)_CP-OFDM_256QAM_Outer_Full_Mid_CH

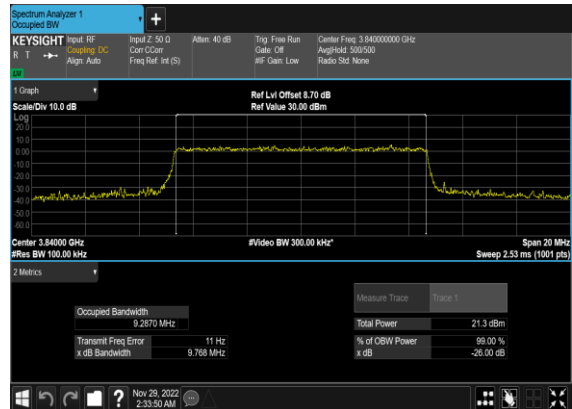

N77(15M)_DFT-s-OFDM_PI_2-BPSK_Outer_Full_Mid_CH

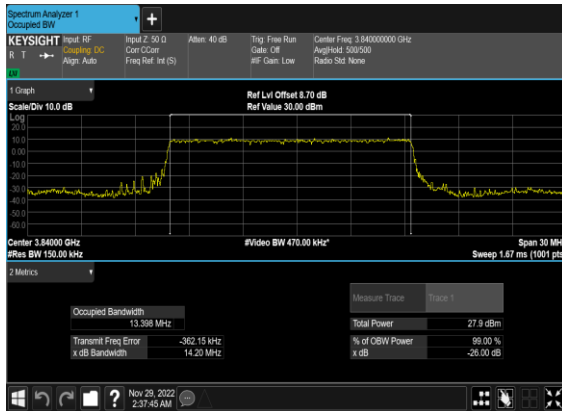

N77(15M)_DFT-s-OFDM_QPSK_Outer_Full_Mid_CH

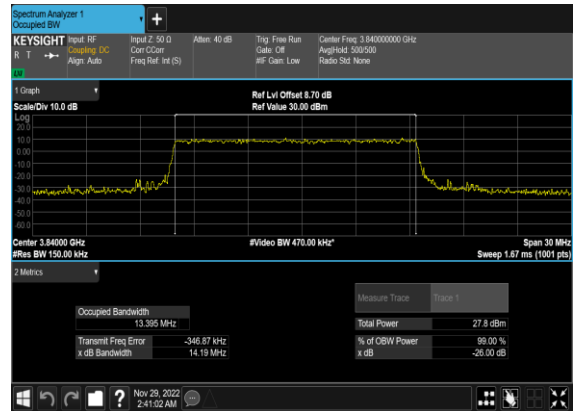

N77(15M)_CP-OFDM_QPSK_Outer_Full_Mid_CH

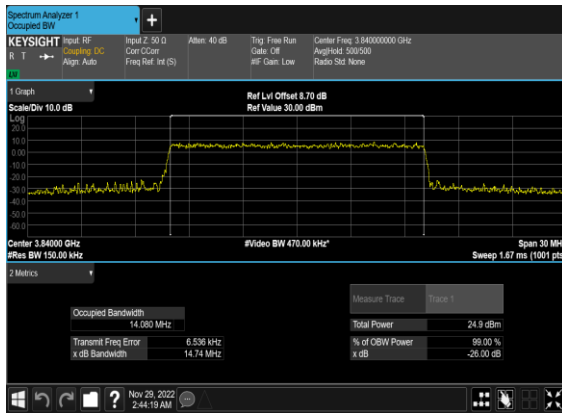

N77(15M)_CP-OFDM_16QAM_Outer_Full_Mid_CH

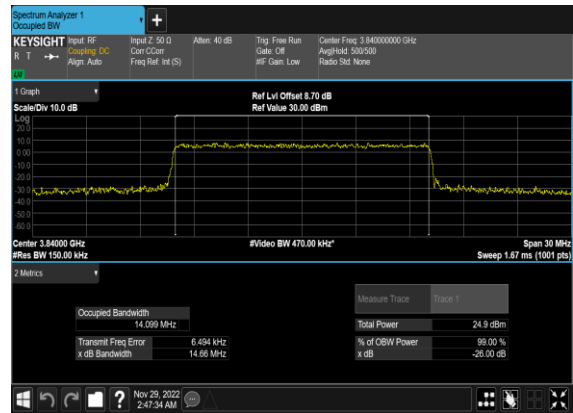

N77(15M)_CP-OFDM_64QAM_Outer_Full_Mid_CH

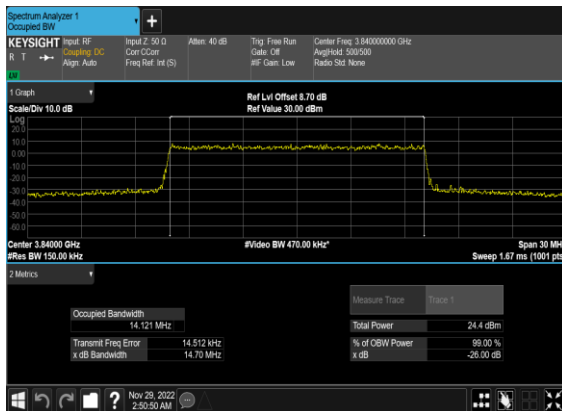

N77(15M)_CP-OFDM_256QAM_Outer_Full_Mid_CH

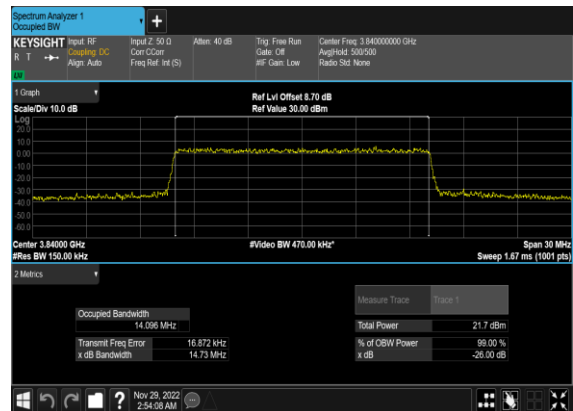

N77(20M)_DFT-s-OFDM_PI_2-BPSK_Outer_Full_Mid_CH

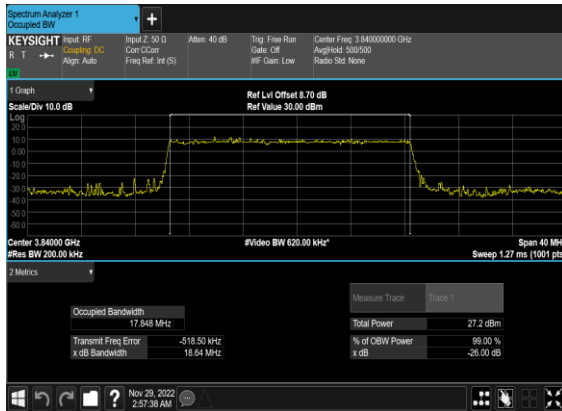

N77(20M)_DFT-s-OFDM_QPSK_Outer_Full_Mid_CH

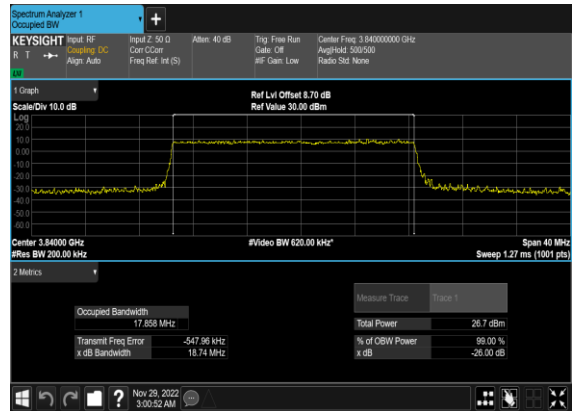

N77(20M)_CP-OFDM_QPSK_Outer_Full_Mid_CH

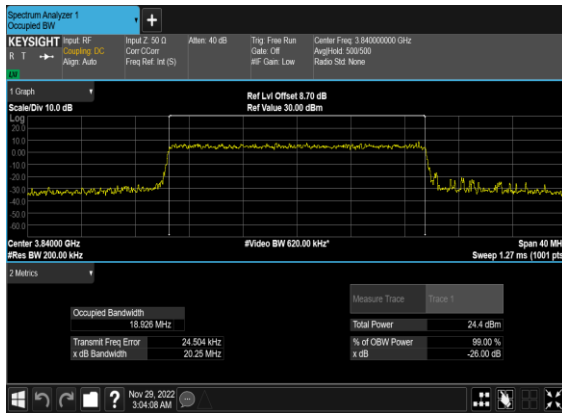

N77(20M)_CP-OFDM_16QAM_Outer_Full_Mid_CH

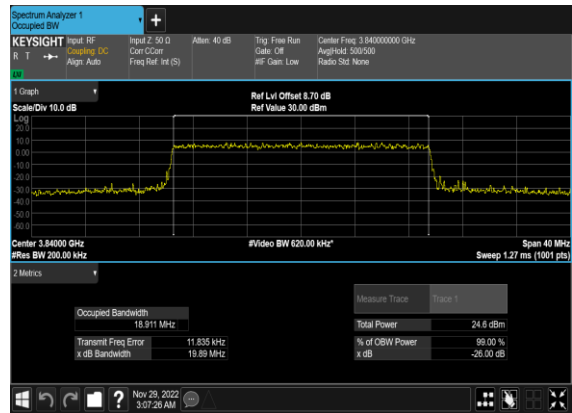

N77(20M)_CP-OFDM_64QAM_Outer_Full_Mid_CH

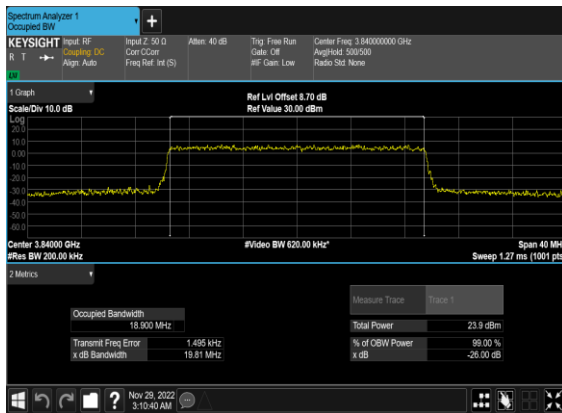

N77(20M)_CP-OFDM_256QAM_Outer_Full_Mid_CH

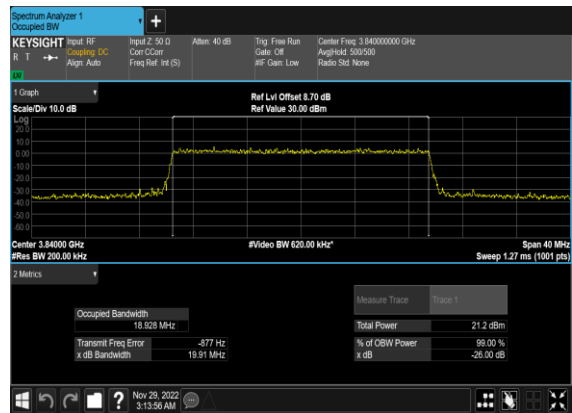

N77(40M)_DFT-s-OFDM_PI_2-BPSK_Outer_Full_Mid_CH

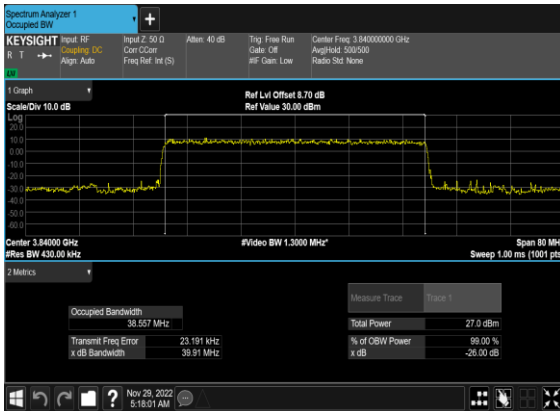

N77(40M)_DFT-s-OFDM_QPSK_Outer_Full_Mid_CH

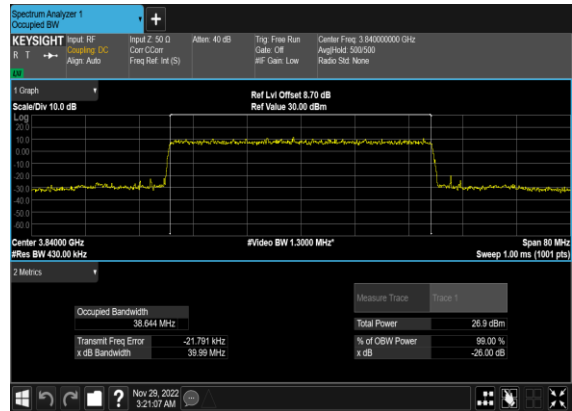

N77(40M)_CP-OFDM_QPSK_Outer_Full_Mid_CH



N77(40M)_CP-OFDM_16QAM_Outer_Full_Mid_CH

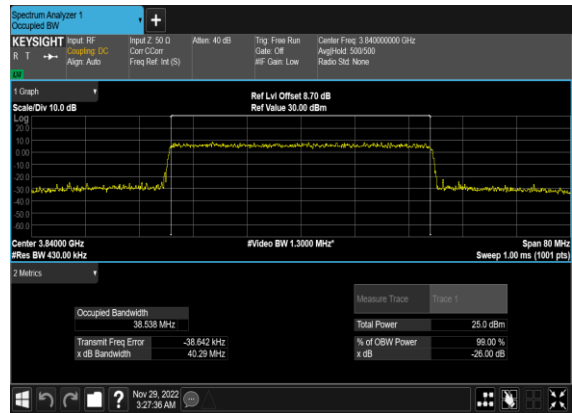

N77(40M)_CP-OFDM_64QAM_Outer_Full_Mid_CH

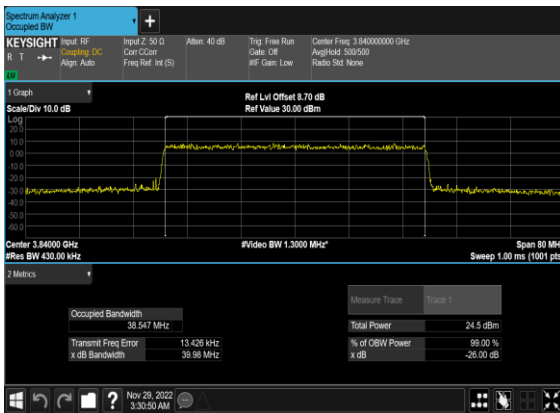

N77(40M)_CP-OFDM_256QAM_Outer_Full_Mid_CH

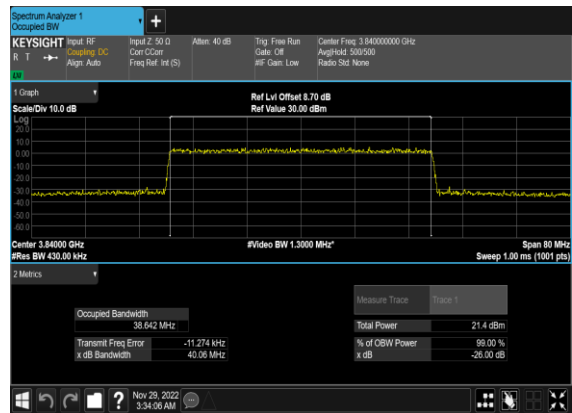

N77(50M)_DFT-s-OFDM_PI_2-BPSK_Outer_Full_Mid_CH

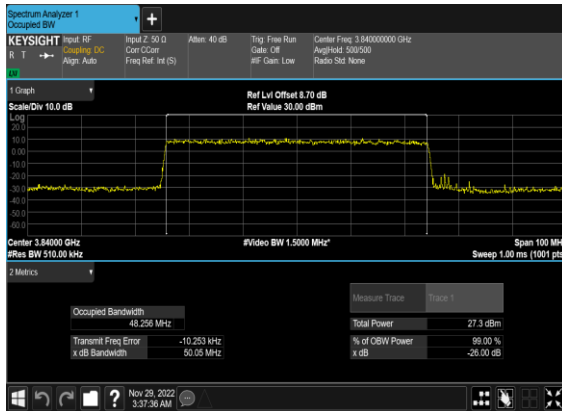

N77(50M)_DFT-s-OFDM_QPSK_Outer_Full_Mid_CH

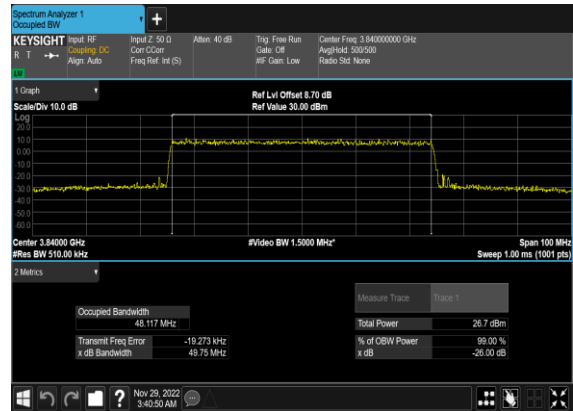

N77(50M)_CP-OFDM_QPSK_Outer_Full_Mid_CH

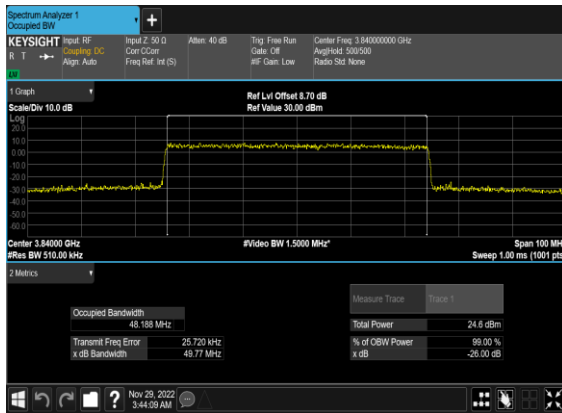

N77(50M)_CP-OFDM_16QAM_Outer_Full_Mid_CH

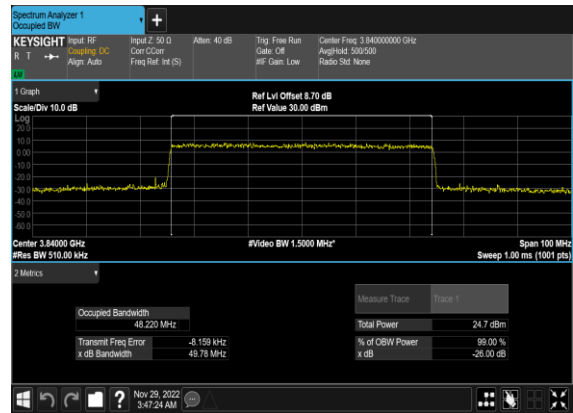

N77(50M)_CP-OFDM_64QAM_Outer_Full_Mid_CH

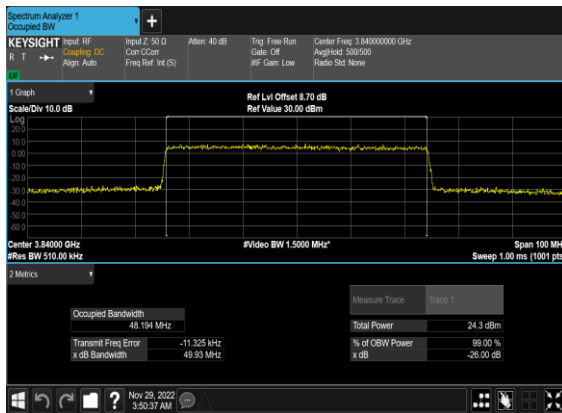

N77(50M)_CP-OFDM_256QAM_Outer_Full_Mid_CH

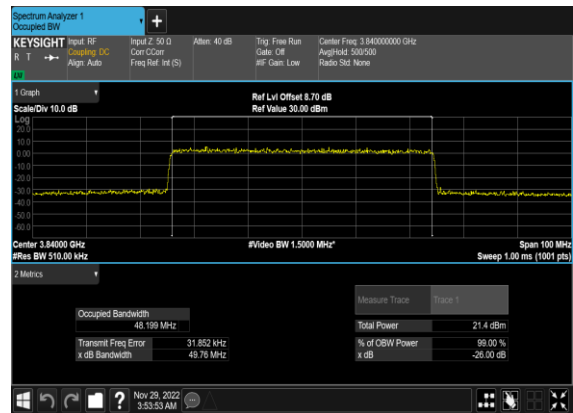

Conducted Spurious Emissions

NR Band	SCS (kHz)	Bandwidth (MHz)	Arfcn	Freq (MHz)	Modulation	RB	Result	Verdict
77	15	10	647000	3705.0	DFT-s-OFDM BPSK	1@0	see graph	---
77	15	10	647000	3705.0	DFT-s-OFDM BPSK	1@0	see graph	PASS
77	15	10	647000	3705.0	DFT-s-OFDM BPSK	1@0	see graph	PASS
77	15	10	647000	3705.0	DFT-s-OFDM QPSK	1@0	see graph	---
77	15	10	647000	3705.0	DFT-s-OFDM QPSK	1@0	see graph	PASS
77	15	10	647000	3705.0	DFT-s-OFDM QPSK	1@0	see graph	PASS
77	15	10	656000	3840.0	DFT-s-OFDM BPSK	1@0	see graph	---
77	15	10	656000	3840.0	DFT-s-OFDM BPSK	1@0	see graph	PASS
77	15	10	656000	3840.0	DFT-s-OFDM BPSK	1@0	see graph	PASS
77	15	10	656000	3840.0	DFT-s-OFDM QPSK	1@0	see graph	---
77	15	10	656000	3840.0	DFT-s-OFDM QPSK	1@0	see graph	PASS
77	15	10	656000	3840.0	DFT-s-OFDM QPSK	1@0	see graph	PASS
77	15	10	665000	3975.0	DFT-s-OFDM BPSK	1@0	see graph	---
77	15	10	665000	3975.0	DFT-s-OFDM BPSK	1@0	see graph	PASS
77	15	10	665000	3975.0	DFT-s-OFDM BPSK	1@0	see graph	PASS
77	15	10	665000	3975.0	DFT-s-OFDM QPSK	1@0	see graph	---
77	15	10	665000	3975.0	DFT-s-OFDM QPSK	1@0	see graph	PASS
77	15	10	665000	3975.0	DFT-s-OFDM QPSK	1@0	see graph	PASS
77	15	20	647334	3710.01	DFT-s-OFDM BPSK	1@0	see graph	---
77	15	20	647334	3710.01	DFT-s-OFDM BPSK	1@0	see graph	PASS
77	15	20	647334	3710.01	DFT-s-OFDM BPSK	1@0	see graph	PASS
77	15	20	647334	3710.01	DFT-s-OFDM QPSK	1@0	see graph	---

77	15	20	647334	3710.01	DFT-s-OFDM QPSK	1@0	see graph	PASS
77	15	20	647334	3710.01	DFT-s-OFDM QPSK	1@0	see graph	PASS
77	15	20	656000	3840.0	DFT-s-OFDM BPSK	1@0	see graph	---
77	15	20	656000	3840.0	DFT-s-OFDM BPSK	1@0	see graph	PASS
77	15	20	656000	3840.0	DFT-s-OFDM BPSK	1@0	see graph	PASS
77	15	20	656000	3840.0	DFT-s-OFDM QPSK	1@0	see graph	---
77	15	20	656000	3840.0	DFT-s-OFDM QPSK	1@0	see graph	PASS
77	15	20	656000	3840.0	DFT-s-OFDM QPSK	1@0	see graph	PASS
77	15	20	664666	3969.99	DFT-s-OFDM BPSK	1@0	see graph	---
77	15	20	664666	3969.99	DFT-s-OFDM BPSK	1@0	see graph	PASS
77	15	20	664666	3969.99	DFT-s-OFDM BPSK	1@0	see graph	PASS
77	15	20	664666	3969.99	DFT-s-OFDM QPSK	1@0	see graph	---
77	15	20	664666	3969.99	DFT-s-OFDM QPSK	1@0	see graph	PASS
77	15	20	664666	3969.99	DFT-s-OFDM QPSK	1@0	see graph	PASS
77	15	50	648334	3725.01	DFT-s-OFDM BPSK	1@0	see graph	---
77	15	50	648334	3725.01	DFT-s-OFDM BPSK	1@0	see graph	PASS
77	15	50	648334	3725.01	DFT-s-OFDM BPSK	1@0	see graph	PASS
77	15	50	648334	3725.01	DFT-s-OFDM QPSK	1@0	see graph	---
77	15	50	648334	3725.01	DFT-s-OFDM QPSK	1@0	see graph	PASS
77	15	50	648334	3725.01	DFT-s-OFDM QPSK	1@0	see graph	PASS
77	15	50	656000	3840.0	DFT-s-OFDM BPSK	1@0	see graph	---
77	15	50	656000	3840.0	DFT-s-OFDM BPSK	1@0	see graph	PASS
77	15	50	656000	3840.0	DFT-s-OFDM BPSK	1@0	see graph	PASS
77	15	50	656000	3840.0	DFT-s-OFDM QPSK	1@0	see graph	---

77	15	50	656000	3840.0	DFT-s-OFDM QPSK	1@0	see graph	PASS
77	15	50	656000	3840.0	DFT-s-OFDM QPSK	1@0	see graph	PASS
77	15	50	663666	3954.99	DFT-s-OFDM BPSK	1@0	see graph	---
77	15	50	663666	3954.99	DFT-s-OFDM BPSK	1@0	see graph	PASS
77	15	50	663666	3954.99	DFT-s-OFDM BPSK	1@0	see graph	PASS
77	15	50	663666	3954.99	DFT-s-OFDM QPSK	1@0	see graph	---
77	15	50	663666	3954.99	DFT-s-OFDM QPSK	1@0	see graph	PASS
77	15	50	663666	3954.99	DFT-s-OFDM QPSK	1@0	see graph	PASS

N77(10M)_DFT-s-OFDM_BPSK_Edge_1RB_Left_Low_CH



N77(10M)_DFT-s-OFDM_BPSK_Edge_1RB_Left_Low_CH

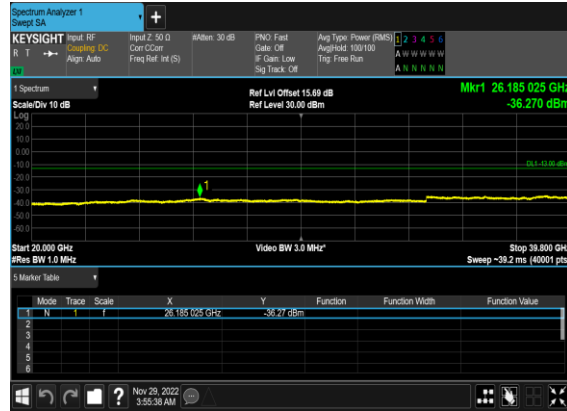

N77(10M)_DFT-s-OFDM_QPSK_Edge_1RB_Left_Low_CH

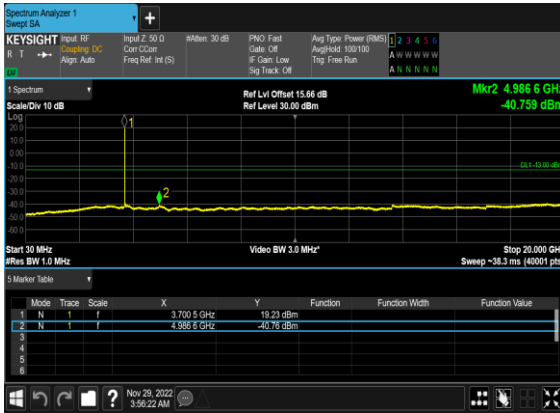

N77(10M)_DFT-s-OFDM_QPSK_Edge_1RB_Left_Low_CH

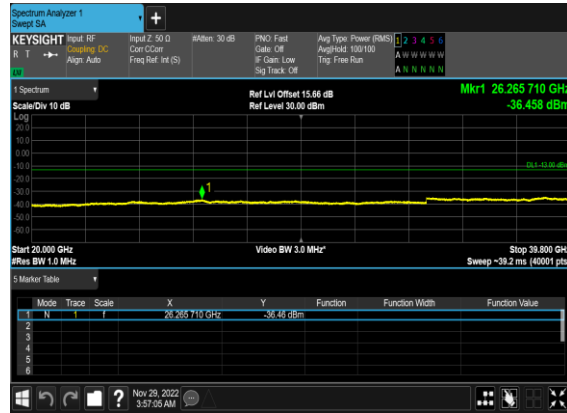

N77(10M)_DFT-s-OFDM_BPSK_Edge_1RB_Left_Mid_CH



N77(10M)_DFT-s-OFDM_BPSK_Edge_1RB_Left_Mid_CH

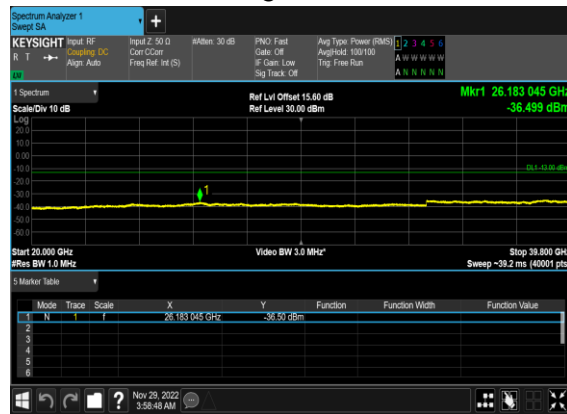

N77(10M)_DFT-s-OFDM_QPSK_Edge_1RB_Left_Mid_CH

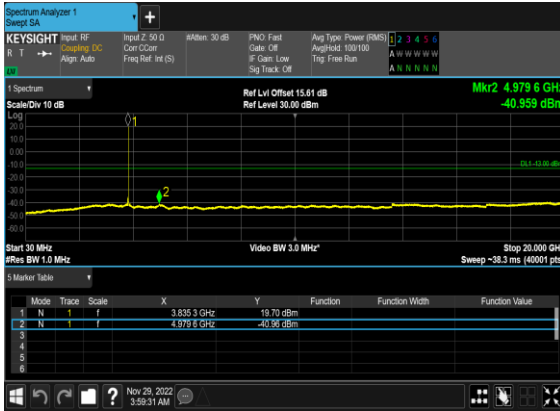

N77(10M)_DFT-s-OFDM_QPSK_Edge_1RB_Left_Mid_CH

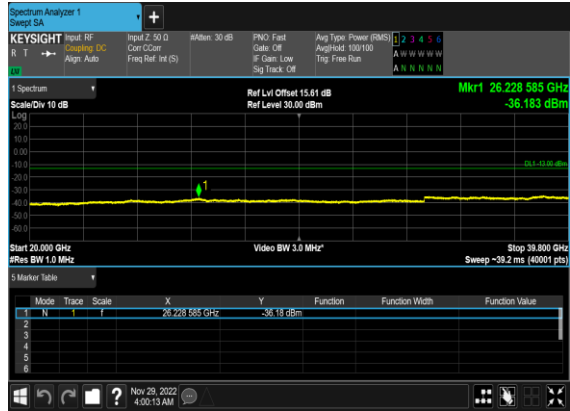

N77(10M)_DFT-s-OFDM_BPSK_Edge_1RB_Left_High_CH

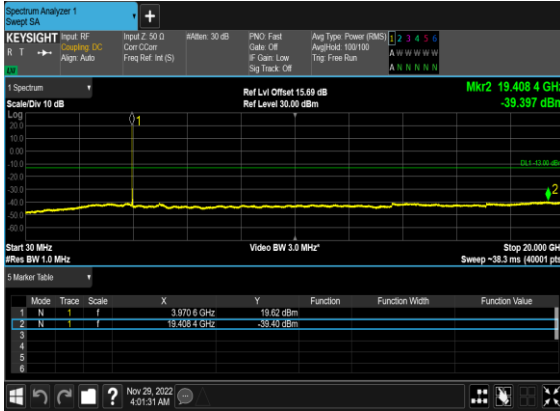

N77(10M)_DFT-s-OFDM_BPSK_Edge_1RB_Left_High_CH

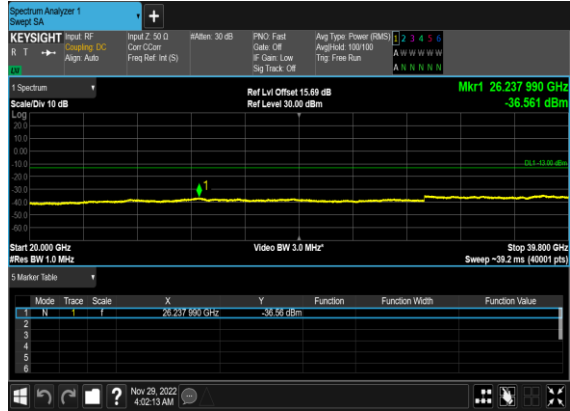

N77(10M)_DFT-s-OFDM_QPSK_Edge_1RB_Left_High_CH

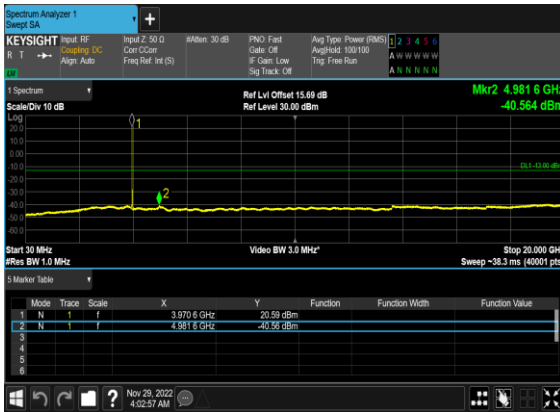

N77(10M)_DFT-s-OFDM_QPSK_Edge_1RB_Left_High_CH

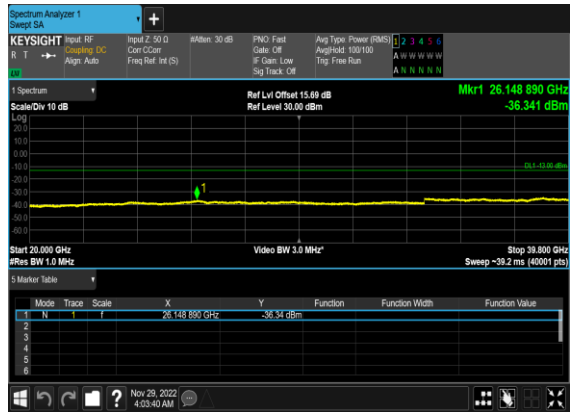

N77(20M)_DFT-s-OFDM_BPSK_Edge_1RB_Left_Low_CH



N77(20M)_DFT-s-OFDM_BPSK_Edge_1RB_Left_Low_CH

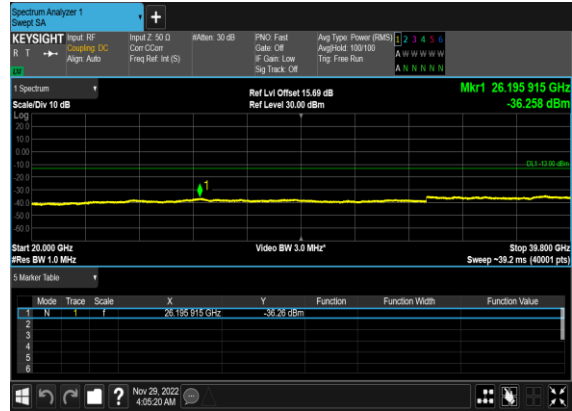

N77(20M)_DFT-s-OFDM_QPSK_Edge_1RB_Left_Low_CH



N77(20M)_DFT-s-OFDM_QPSK_Edge_1RB_Left_Low_CH



N77(20M)_DFT-s-OFDM_BPSK_Edge_1RB_Left_Mid_CH

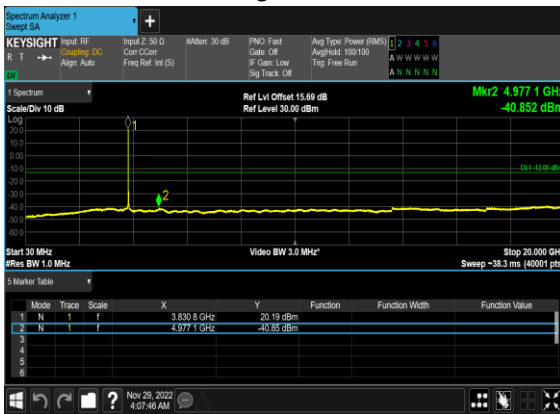

N77(20M)_DFT-s-OFDM_BPSK_Edge_1RB_Left_Mid_CH

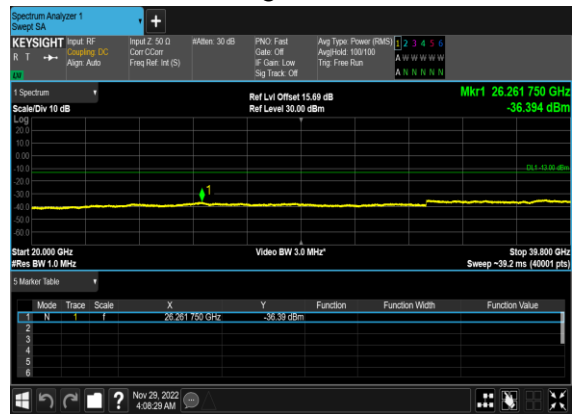

N77(20M)_DFT-s-OFDM_QPSK_Edge_1RB_Left_Mid_CH

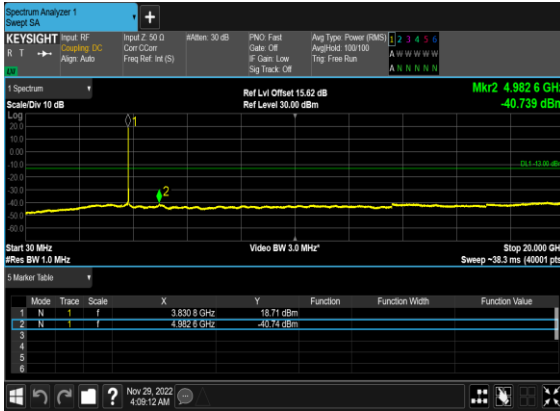

N77(20M)_DFT-s-OFDM_QPSK_Edge_1RB_Left_Mid_CH

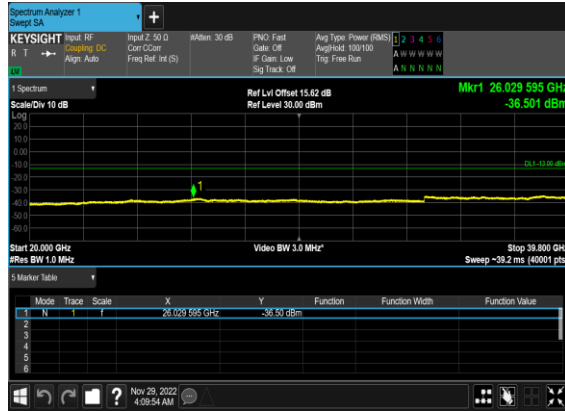

N77(20M)_DFT-s-OFDM_BPSK_Edge_1RB_Left_High_CH



N77(20M)_DFT-s-OFDM_BPSK_Edge_1RB_Left_High_CH

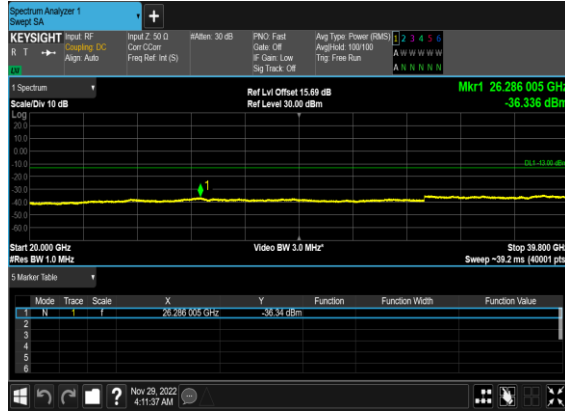

N77(20M)_DFT-s-OFDM_QPSK_Edge_1RB_Left_High_CH

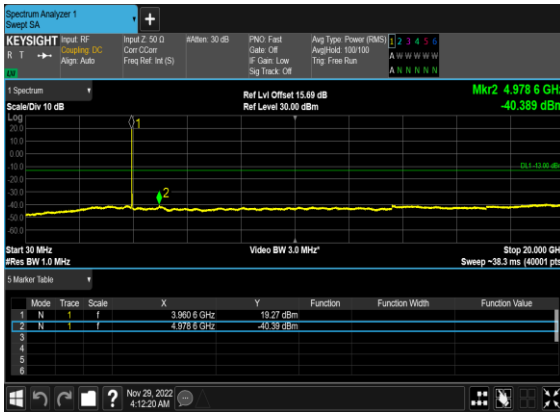

N77(20M)_DFT-s-OFDM_QPSK_Edge_1RB_Left_High_CH

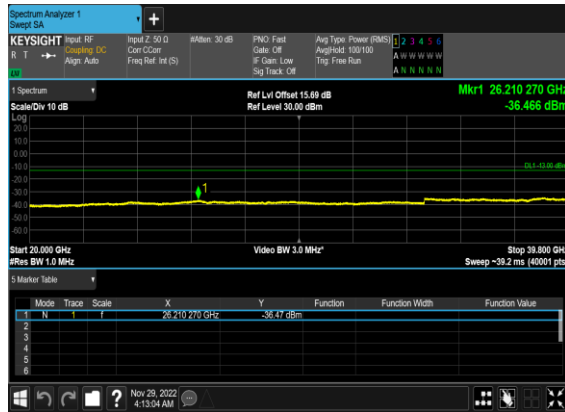

N77(50M)_DFT-s-OFDM_BPSK_Edge_1RB_Left_Low_CH

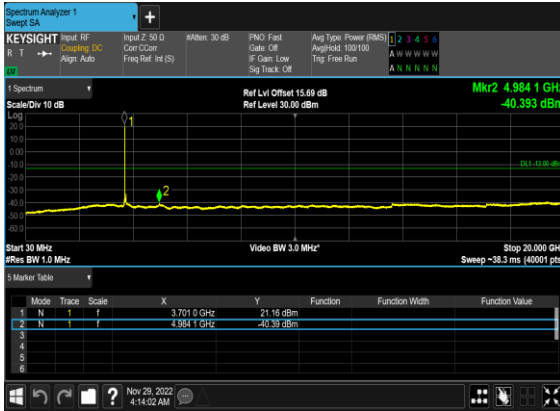

N77(50M)_DFT-s-OFDM_BPSK_Edge_1RB_Left_Low_CH

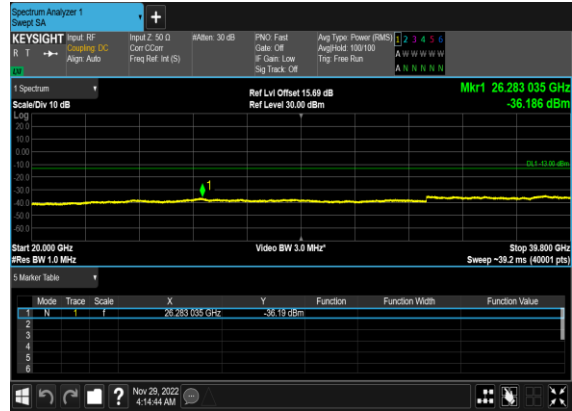

N77(50M)_DFT-s-OFDM_QPSK_Edge_1RB_Left_Low_CH



N77(50M)_DFT-s-OFDM_QPSK_Edge_1RB_Left_Low_CH

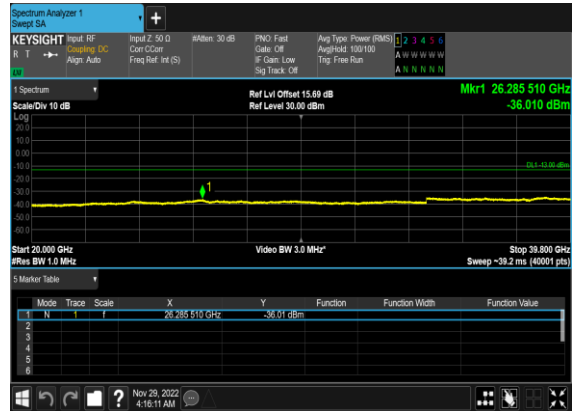

N77(50M)_DFT-s-OFDM_BPSK_Edge_1RB_Left_Mid_CH

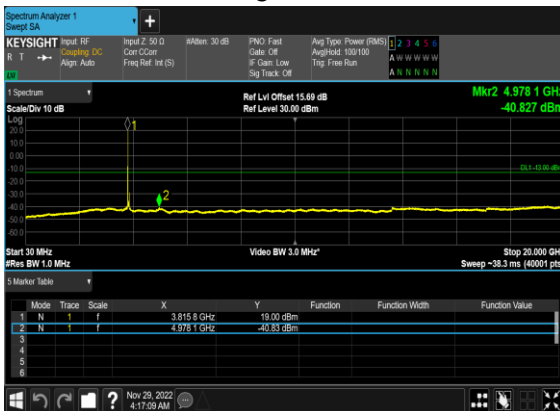

N77(50M)_DFT-s-OFDM_BPSK_Edge_1RB_Left_Mid_CH

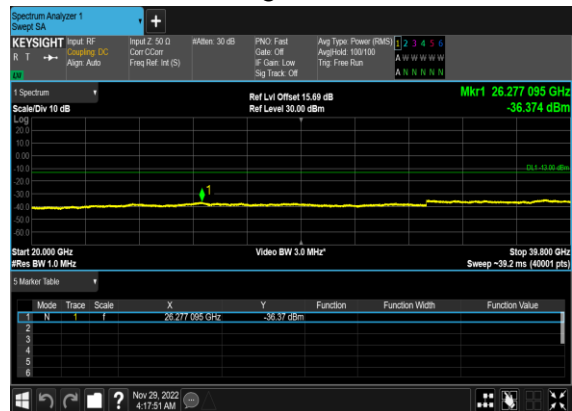

N77(50M)_DFT-s-OFDM_QPSK_Edge_1RB_Left_Mid_CH

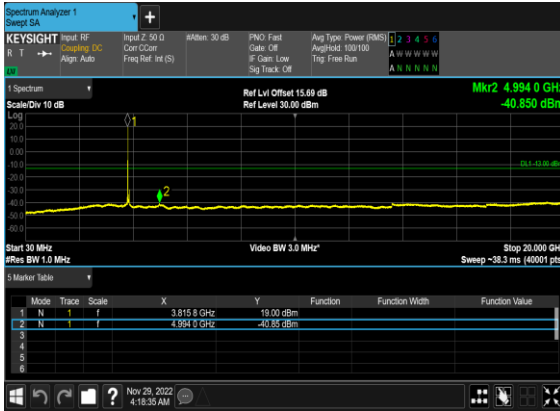

N77(50M)_DFT-s-OFDM_QPSK_Edge_1RB_Left_Mid_CH

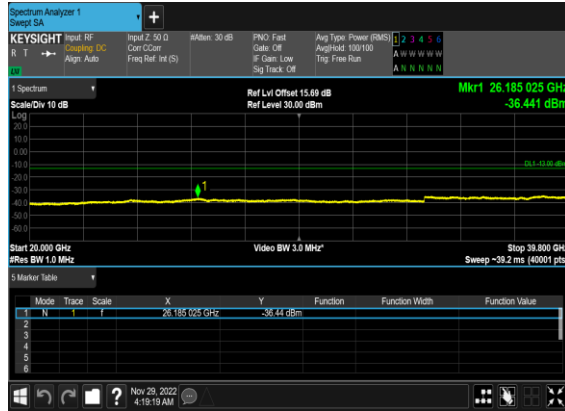

N77(50M)_DFT-s-OFDM_BPSK_Edge_1RB_Left_High_CH

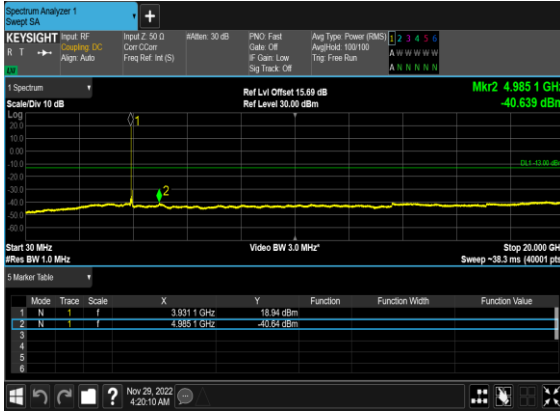

N77(50M)_DFT-s-OFDM_BPSK_Edge_1RB_Left_High_CH

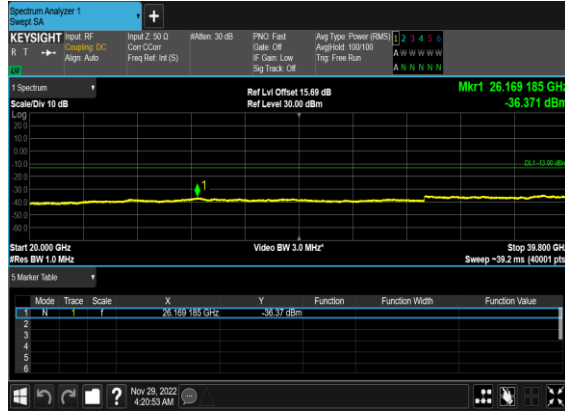

N77(50M)_DFT-s-OFDM_QPSK_Edge_1RB_Left_High_CH



N77(50M)_DFT-s-OFDM_QPSK_Edge_1RB_Left_High_CH

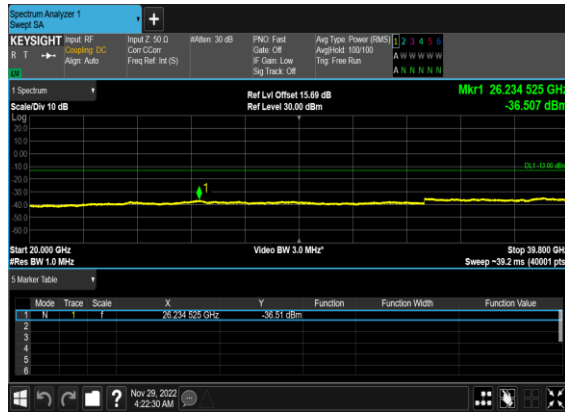

Conducted Band Edge

NR Band	SCS (kHz)	Bandwidth (MHz)	Arfcn	Freq (MHz)	Modulation	RB	Result	Verdict
77	15	10	647000	3705.0	DFT-s-OFDM BPSK	1@0	see graph	PASS
77	15	10	647000	3705.0	DFT-s-OFDM QPSK	1@0	see graph	PASS
77	15	10	647000	3705.0	DFT-s-OFDM BPSK	50@0	see graph	PASS
77	15	10	647000	3705.0	DFT-s-OFDM QPSK	50@0	see graph	PASS
77	15	10	665000	3975.0	DFT-s-OFDM BPSK	1@51	see graph	PASS
77	15	10	665000	3975.0	DFT-s-OFDM QPSK	1@51	see graph	PASS
77	15	10	665000	3975.0	DFT-s-OFDM BPSK	50@0	see graph	PASS
77	15	10	665000	3975.0	DFT-s-OFDM QPSK	50@0	see graph	PASS
77	15	20	647334	3710.01	DFT-s-OFDM BPSK	1@0	see graph	PASS
77	15	20	647334	3710.01	DFT-s-OFDM QPSK	1@0	see graph	PASS
77	15	20	647334	3710.01	DFT-s-OFDM BPSK	100@0	see graph	PASS
77	15	20	647334	3710.01	DFT-s-OFDM QPSK	100@0	see graph	PASS
77	15	20	664666	3969.99	DFT-s-OFDM BPSK	1@105	see graph	PASS
77	15	20	664666	3969.99	DFT-s-OFDM QPSK	1@105	see graph	PASS
77	15	20	664666	3969.99	DFT-s-OFDM BPSK	100@0	see graph	PASS
77	15	20	664666	3969.99	DFT-s-OFDM QPSK	100@0	see graph	PASS
77	15	50	648334	3725.01	DFT-s-OFDM BPSK	1@0	see graph	PASS
77	15	50	648334	3725.01	DFT-s-OFDM QPSK	1@0	see graph	PASS
77	15	50	648334	3725.01	DFT-s-OFDM BPSK	270@0	see graph	PASS
77	15	50	648334	3725.01	DFT-s-OFDM QPSK	270@0	see graph	PASS
77	15	50	663666	3954.99	DFT-s-OFDM BPSK	1@269	see graph	PASS
77	15	50	663666	3954.99	DFT-s-OFDM QPSK	1@269	see graph	PASS

77	15	50	663666	3954.99	DFT-s-OFDM BPSK	270@0	see graph	PASS
77	15	50	663666	3954.99	DFT-s-OFDM QPSK	270@0	see graph	PASS

N77(10M)_DFT-s-OFDM_BPSK_Edge_1RB_Left_Low_CH



N77(10M)_DFT-s-OFDM_QPSK_Edge_1RB_Left_Low_CH

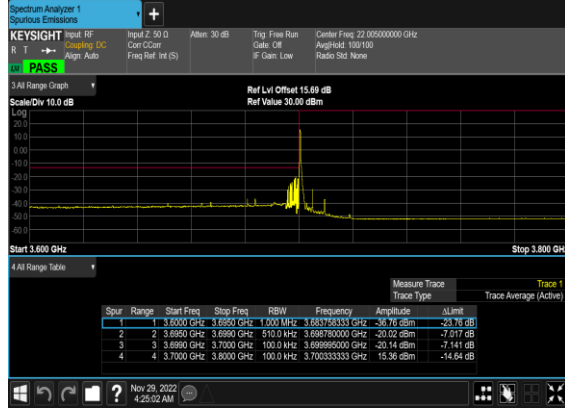

N77(10M)_DFT-s-OFDM_BPSK_Outer_Full_Low_CH



N77(10M)_DFT-s-OFDM_QPSK_Outer_Full_Low_CH

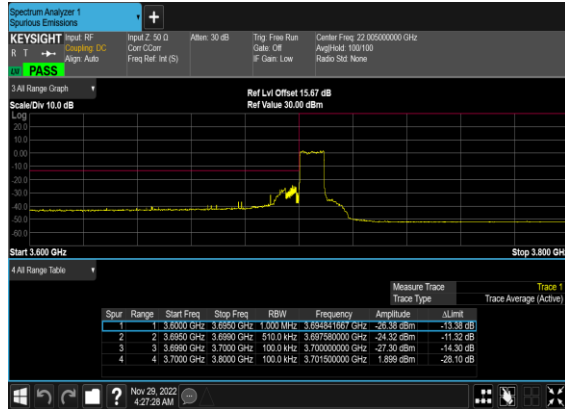

N77(10M)_DFT-s-OFDM_BPSK_Edge_1RB_Right_High_CH

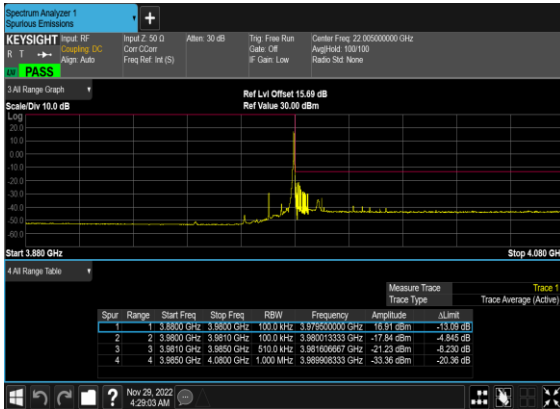

N77(10M)_DFT-s-OFDM_QPSK_Edge_1RB_Right_High_CH

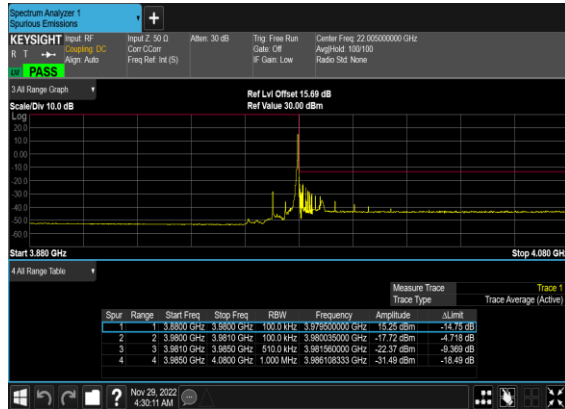

N77(10M)_DFT-s-OFDM_BPSK_Outer_Full_High_CH

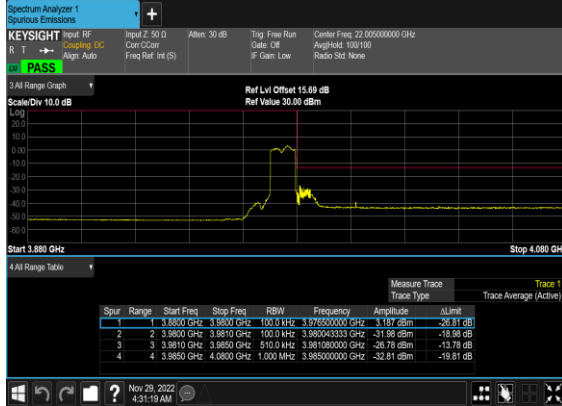

N77(10M)_DFT-s-OFDM_QPSK_Outer_Full_High_CH

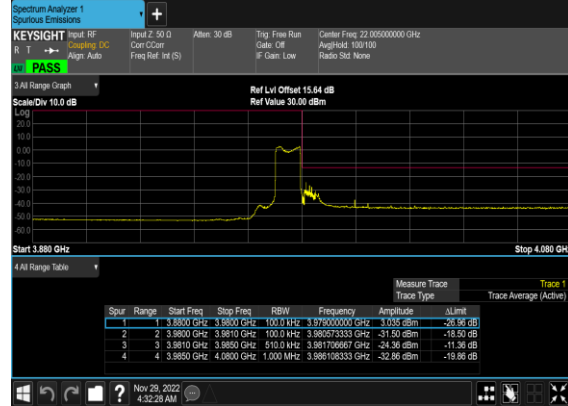

N77(20M)_DFT-s-OFDM_BPSK_Edge_1RB_Left_Low_CH



N77(20M)_DFT-s-OFDM_QPSK_Edge_1RB_Left_Low_CH



N77(20M)_DFT-s-OFDM_BPSK_Outer_Full_Low_CH

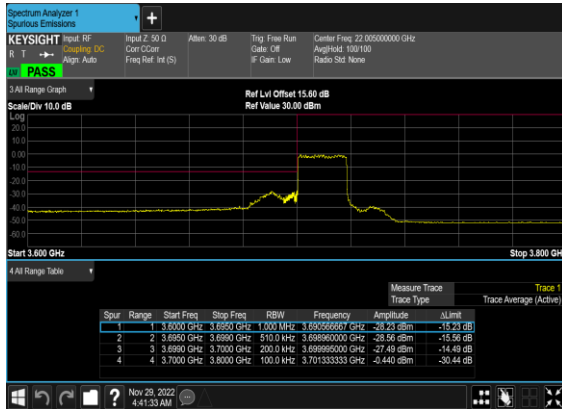

N77(20M)_DFT-s-OFDM_QPSK_Outer_Full_Low_CH

