



FCC RF Test Report

APPLICANT : Bullitt Group
EQUIPMENT : Rugged Smart Phone
BRAND NAME : CAT
MODEL NAME : BM1S1B
FCC ID : ZL5BM1S1BE
STANDARD : 47 CFR Part 2, Part 27 Subpart Q
CLASSIFICATION : PCS Licensed Transmitter Held to Ear (PCE)
TEST DATE(S) : Nov. 16, 2022 ~ Dec. 07, 2022

We, Sporton International Inc. (Shenzhen), would like to declare that the tested sample has been evaluated in accordance with the procedures given in ANSI C63.26-2015 and shown compliance with the applicable technical standards.

The test results in this report apply exclusively to the tested model / sample. Without written approval of Sporton International Inc. (Shenzhen), the test report shall not be reproduced except in full.

Jason Jia



Approved by: Jason Jia

Sporton International Inc. (ShenZhen)

1/F, 2/F, Bldg 5, Shiling Industrial Zone, Xinwei Village, Xili, Nanshan, Shenzhen, 518055

People's Republic of China



TABLE OF CONTENTS

REVISION HISTORY..... 3
SUMMARY OF TEST RESULT 4
1 GENERAL DESCRIPTION 5
1.1 Applicant 5
1.2 Manufacturer 5
1.3 Product Feature of Equipment Under Test 5
1.4 Product Specification of Equipment Under Test 5
1.5 Modification of EUT 6
1.6 Maximum EIRP Power and Emission Designator 6
1.7 Testing Site 8
1.8 Test Software 8
1.9 Applied Standards 8
2 TEST CONFIGURATION OF EQUIPMENT UNDER TEST 9
2.1 Test Mode 9
2.2 Connection Diagram of Test System 11
2.3 Support Unit used in test configuration and system 11
2.4 Measurement Results Explanation Example 11
2.5 Frequency List of Low/Middle/High Channels 12
3 CONDUCTED TEST ITEMS 14
3.1 Measuring Instruments 14
3.2 Test Setup 14
3.3 Test Result of Conducted Test 14
3.4 Conducted Output Power Measurement 15
3.5 Peak-to-Average Ratio 16
3.6 EIRP 17
3.7 Occupied Bandwidth 18
3.8 Conducted Band Edge Measurement 19
3.9 Conducted Spurious Emission Measurement 20
3.10 Frequency Stability Measurement 21
4 RADIATED TEST ITEMS 22
4.1 Measuring Instruments 22
4.2 Test Setup 22
4.3 Test Result of Radiated Test 23
4.4 Radiated Spurious Emission Measurement 24
5 LIST OF MEASURING EQUIPMENT 25
6 UNCERTAINTY OF EVALUATION 26
APPENDIX A. TEST RESULTS OF CONDUCTED TEST
APPENDIX B. TEST RESULTS OF RADIATED TEST
APPENDIX C. TEST SETUP PHOTOGRAPHS

SUMMARY OF TEST RESULT

Report Section	FCC Rule	Description	Limit	Result	Remark
3.4	§2.1046	Conducted Output Power	—	Report Only	-
3.5	§27.50 (k)(4)	Peak-to-Average Ratio	<13dB	PASS	
3.6	§27.50 (k)(3)	EIRP	EIRP < 1W (30dBm)	PASS	-
3.7	§2.1049	Occupied Bandwidth	—	Report Only	-
3.8	§2.1051 §27.53 (n)(2)	Conducted Band Edge Measurement	-13dBm/MHz	PASS	-
3.9	§2.1051 §27.53 (n)(2)	Conducted Spurious Emission	-13dBm/MHz	PASS	-
3.10	§2.1055 §27.54	Frequency Stability Temperature & Voltage	Within the band	PASS	-
4.4	§2.1053 §27.53 (n)(2)	Radiated Spurious Emission	-13dBm/MHz	PASS	Under limit 31.34 dB at 10104.36 MHz

Declaration of Conformity:

The test results with all measurement uncertainty excluded are presented in accordance with the regulation limits or requirements declared by manufacturers.

Comments and Explanations:

The declared of product specification for EUT presented in the report are provided by the manufacturer, and the manufacturer takes all the responsibilities for the accuracy of product specification.

1 General Description

1.1 Applicant

Bullitt Group

One Valpy, Valpy Street, Reading, Berkshire, RG1 1AR, United Kingdom

1.2 Manufacturer

Bullitt Mobile Limited

One Valpy, Valpy Street, Reading, Berkshire, RG1 1AR, United Kingdom

1.3 Product Feature of Equipment Under Test

Product Feature	
Equipment	Rugged Smart Phone
Brand Name	CAT
Model Name	BM1S1B
FCC ID	ZL5BM1S1BE
IMEI Code	Conducted : 352089780001316/352089780002819 Radiation : 352089780000334/352089780001837
EUT Stage	Identical Prototype

1.4 Product Specification of Equipment Under Test

Product Feature	
Tx/Rx Frequency	5G NR n77: 3450 MHz ~ 3550 MHz 5G NR n78: 3450 MHz ~ 3550 MHz
Bandwidth	5G NR n77/n78: 10MHz / 15MHz / 20MHz / 40MHz / 50MHz for 15kHz 10MHz / 15MHz / 20MHz / 40MHz / 50MHz / 60MHz / 80MHz / 90MHz / 100MHz for 30kHz
SCS	15kHz, 30kHz
Antenna Gain	<Ant. 2>: 5G NR n77 : -2.7 dBi 5G NR n78 : -2.7 dBi <Ant. 4>: 5G NR n77 : -2.7 dBi 5G NR n78 : -2.7 dBi <Ant. 6>: 5G NR n77 : -1.4 dBi 5G NR n78 : -1.4 dBi <Ant. 11>: 5G NR n77 : -2.1 dBi 5G NR n78 : -2.1 dBi
Type of Modulation	CP-OFDM: QPSK / 16QAM / 64QAM / 256QAM DFT-s-OFDM: PI/2 BPSK / QPSK / 16QAM / 64QAM / 256QAM

Remark:

1. The maximum EIRP is calculated from max output power and max antenna gain, only the maximum EIRP are shown in the report, 5G NR n77/n78 for Ant. 6.
2. All the supported ENDC combinations are verified conducted power, only the ENDC combination with highest power are shown in the report.
3. 5G NR support SA (n77/n78) mode and NSA(n77/n78) mode. According to the maximum power between SA and NSA mode, SA covers NSA mode.
4. The device supports HPUE mode for 5G NR n78.
5. The EN-DC mode combination could be referred to the product spec.

1.5 Modification of EUT

No modifications are made to the EUT during all test items.

1.6 Maximum EIRP Power and Emission Designator

5G NR n77-SCS 15kHz		PI/2 BPSK / QPSK		16QAM/64QAM/256QAM	
BW (MHz)	Frequency Range (MHz)	Maximum EIRP(W)	Emission Designator (99%OBW)	Maximum EIRP(W)	Emission Designator (99%OBW)
10	3455.01 ~ 3544.995	0.1315	9M28G7D	0.1050	9M28W7D
15	3457.50 ~ 3542.49	0.1358	14M1G7D	0.1140	14M1W7D
20	3460.005 ~ 3540.00	0.1352	18M9G7D	0.1074	18M9W7D
40	3470.01 ~ 3529.995	0.1239	38M6G7D	0.0989	38M6W7D
50	3475.005 ~ 3525.00	0.1371	48M2G7D	0.1084	48M2W7D

5G NR n77-SCS 30kHz		PI/2 BPSK / QPSK		16QAM/64QAM/256QAM	
BW (MHz)	Frequency Range (MHz)	Maximum EIRP(W)	Emission Designator (99%OBW)	Maximum EIRP(W)	Emission Designator (99%OBW)
10	3455.01 ~ 3544.98	0.1346	8M58G7D	0.1117	8M59W7D
15	3457.50 ~ 3542.49	0.1330	13M6G7D	0.1099	13M6W7D
20	3460.02 ~ 3540.00	0.1327	18M2G7D	0.1104	18M2W7D
40	3470.01 ~ 3529.98	0.1236	37M7G7D	0.1035	37M9W7D
50	3475.02 ~ 3525.00	0.1321	47M5G7D	0.1091	47M5W7D
60	3480.00 ~ 3519.99	0.1279	57M9G7D	0.1072	57M8W7D
80	3490.02 ~ 3510.00	0.1236	77M4G7D	0.1026	77M5W7D
90	3495.00 ~ 3504.99	0.1194	87M3G7D	0.1016	87M5W7D
100	3500.01	0.1358	97M2G7D	0.1076	97M3W7D



5G NR n78-SCS 15kHz		PI/2 BPSK / QPSK		16QAM/64QAM/256QAM	
BW (MHz)	Frequency Range (MHz)	Maximum EIRP(W)	Emission Designator (99%OBW)	Maximum EIRP(W)	Emission Designator (99%OBW)
10	3455.01 ~ 3544.995	0.2612	9M28G7D	0.2084	9M28W7D
15	3457.50 ~ 3542.49	0.2692	14M1G7D	0.2188	14M1W7D
20	3460.005 ~ 3540.00	0.2685	18M9G7D	0.2173	18M9W7D
40	3470.01 ~ 3529.995	0.2393	38M6G7D	0.1941	38M6W7D
50	3475.005 ~ 3525.00	0.2710	48M2G7D	0.2153	48M2W7D

5G NR n78-SCS 30kHz		PI/2 BPSK / QPSK		16QAM/64QAM/256QAM	
BW (MHz)	Frequency Range (MHz)	Maximum EIRP(W)	Emission Designator (99%OBW)	Maximum EIRP(W)	Emission Designator (99%OBW)
10	3455.01 ~ 3544.98	0.2642	8M58G7D	0.2193	8M59W7D
15	3457.50 ~ 3542.49	0.2612	13M6G7D	0.2203	13M6W7D
20	3460.02 ~ 3540.00	0.2624	18M2G7D	0.2178	18M2W7D
40	3470.01 ~ 3529.98	0.2399	37M7G7D	0.1734	37M9W7D
50	3475.02 ~ 3525.00	0.2576	47M5G7D	0.2094	47M5W7D
60	3480.00 ~ 3519.99	0.2477	57M9G7D	0.2056	57M8W7D
80	3490.02 ~ 3510.00	0.2432	77M4G7D	0.1986	77M4W7D
90	3495.00 ~ 3504.99	0.2344	87M3G7D	0.1941	87M5W7D
100	3500.01	0.2655	97M2G7D	0.1910	97M3W7D

Note:

1. 5G NR Band n78 overlaps the entire frequency range of Band n77, and n78 power > n77 power, therefore the conducted test results of n78 provided in this report cover n77.
2. All modulations have been tested, and only the worst test results of PSK & QAM are shown in the report.

1.7 Testing Site

Sporton International Inc. (ShenZhen) is accredited to ISO/IEC 17025:2017 by American Association for Laboratory Accreditation with Certificate Number 5145.01.

Test Firm	Sporton International Inc. (ShenZhen)		
Test Site Location	1/F, 2/F, Bldg 5, Shiling Industrial Zone, Xinwei Village, Xili, Nanshan, Shenzhen, 518055 People's Republic of China TEL: +86-755-86379589 FAX: +86-755-86379595		
Test Site No.	Sporton Site No.	FCC Designation No.	FCC Test Firm Registration No.
	TH01-SZ	CN1256	421272

Test Firm	Sporton International Inc. (ShenZhen)		
Test Site Location	101, 1st Floor, Block B, Building 1, No. 2, Tengfeng 4th Road, Fenghuang Community, Fuyong Street, Baoan District, Shenzhen City Guangdong Province China 518103 TEL: +86-755-33202398		
Test Site No.	Sporton Site No.	FCC Designation No.	FCC Test Firm Registration No.
	03CH03-SZ	CN1256	421272

1.8 Test Software

Item	Site	Manufacturer	Name	Version
1.	03CH03-SZ	AUDIX	E3	6.2009-8-24

1.9 Applied Standards

According to the specifications of the manufacturer, the EUT must comply with the requirements of the following standards:

- ♦ 47 CFR Part 2, Part 27 Subpart Q
- ♦ ANSI C63.26-2015
- ♦ FCC KDB 971168 Power Meas License Digital Systems D01 v03r01
- ♦ FCC KDB 412172 D01 Determining ERP and EIRP v01r01

Remark:

1. All test items were verified and recorded according to the standards and without any deviation during the test.
2. This EUT has also been tested and complied with the requirements of FCC Part 15, Subpart B, recorded in a separate test report.



2 Test Configuration of Equipment Under Test

2.1 Test Mode

Antenna port conducted and radiated test items listed below are performed according to KDB 971168 D01 Power Meas. License Digital Systems v03r01 with maximum output power.

Radiated measurements are performed by rotating the EUT in three different orthogonal test planes to find the maximum emission. (X-Plane)

SCS 15KHz

Test Items	5G NR	Bandwidth (MHz)													Modulation					RB #		Test Channel		
		5	10	15	20	25	30	40	50	60	70	80	90	100	PI/2 BPSK	QPSK	16QAM	64QAM	256QAM	1	Full	L	M	H
Max. Output Power	n77	-	v	v	v	-	-	v	v						v	v	v	v	v	v	v	v	v	v
	n78	-	v	v	v	-	-	v	v						v	v	v	v	v	v	v	v	v	v
Peak-to-Average Ratio	n78	-			v	-	-								v	v				v	v	v	v	v
26dB and 99% Bandwidth	n78	-	v	v	v	-	-	v	v						v	v	v	v	v		v			v
Conducted Band Edge	n78	-	v		v	-	-		v						v	v				v	v	v		v
Conducted Spurious Emission	n78	-	v		v	-	-		v						v	v				v		v	v	v
Frequency Stability	n78	-			v	-	-									v					v			v
E.I.R.P	n77	-	v	v	v	-	-	v	v						v	v	v	v	v	v	v	v	v	v
	n78	-	v	v	v	-	-	v	v						v	v	v	v	v	v	v	v	v	v
Note	<ol style="list-style-type: none"> The mark "v" means that this configuration is chosen for testing The mark "-" means that this bandwidth is not supported. The device is investigated from 30MHz to 10 times of fundamental signal for radiated spurious emission test under different RB size/offset and modulations in exploratory test. Subsequently, only the worst case emissions are reported. Frequency Stability : Normal Voltage = 3.87V ; Low Voltage =3.6V. ; High Voltage =4.40V 																							



SCS 30KHz

Test Items	5G NR	Bandwidth (MHz)													Modulation				RB #		Test Channel		
		5	10	15	20	25	30	40	50	60	70	80	90	100	PI/2 BPSK	QPSK	16QAM	64QAM	256QAM	1	Full	L	M
Max. Output Power	n77	-	v	v	v	-	-	v	v	v	-	v	v	v	v	v	v	v	v	v	v	v	v
	n78	-	v	v	v	-	-	v	v	v	-	v	v	v	v	v	v	v	v	v	v	v	v
Peak-to-Average Ratio	n78	-			v	-	-				-				v	v				v	v	v	v
26dB and 99% Bandwidth	n78	-	v	v	v	-	-	v	v	v	-	v	v	v	v	v	v	v	v		v		
Conducted Band Edge	n78	-	v			-	-		v		-			v	v	v				v	v	v	v
Conducted Spurious Emission	n78	-	v			-	-		v		-			v	v	v				v		v	v
Frequency Stability	n78	-			v	-	-				-					v					v		v
E.I.R.P	n77	-	v	v	v	-	-	v	v	v	-	v	v	v	v	v	v	v	v	v	v	v	v
	n78	-	v	v	v	-	-	v	v	v	-	v	v	v	v	v	v	v	v	v	v	v	v
Radiated Spurious Emission	n78	Worst Case																					v
Note	1. The mark "v " means that this configuration is chosen for testing 2. The mark "- " means that this bandwidth is not supported. 3. The device is investigated from 30MHz to 10 times of fundamental signal for radiated spurious emission test under different RB size/offset and modulations in exploratory test. Subsequently, only the worst case emissions are reported. 4. Frequency Stability : Normal Voltage = 3.87V ; Low Voltage =3.6V. ; High Voltage =4.40V																						

2.2 Connection Diagram of Test System

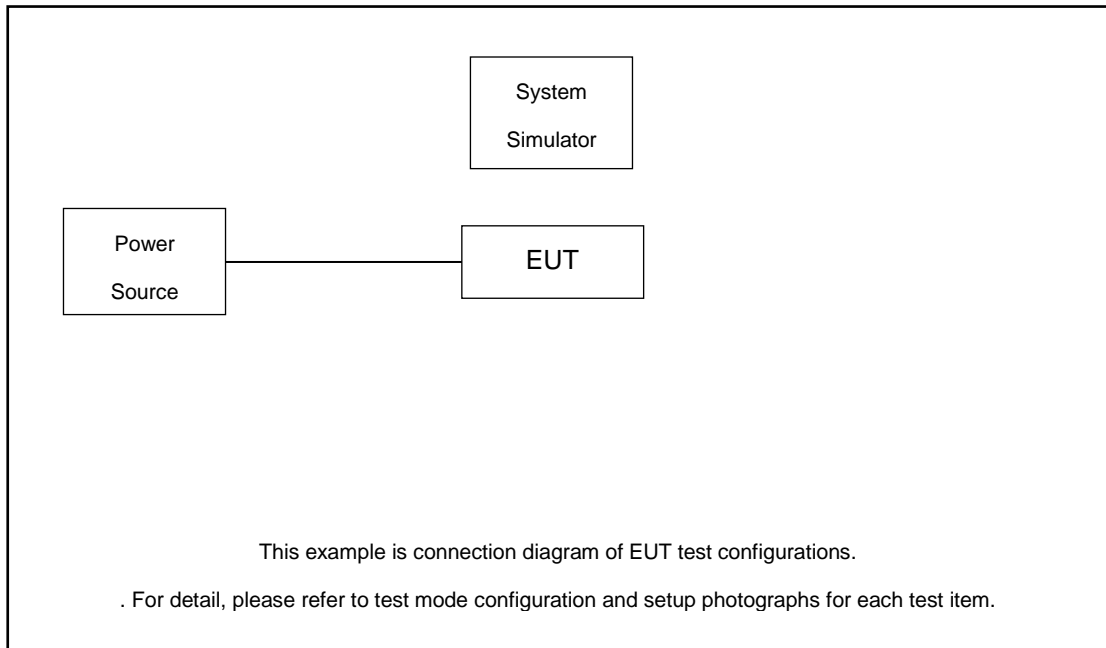

2.3 Support Unit used in test configuration and system

Item	Equipment	Trade Name	Model No.	FCC ID	Data Cable	Power Cord
1.	Power Supply	GWINSTEK	PSS-2002	N/A	N/A	Unshielded, 1.8 m
2.	LTE Base Station	Anritsu	MT8821C	N/A	N/A	Unshielded, 1.8 m
3.	NR Base Station	Anritsu	MT8000A	N/A	N/A	Unshielded, 1.8 m

2.4 Measurement Results Explanation Example

For all conducted test items:

The offset level is set in the spectrum analyzer to compensate the RF cable loss between EUT conducted output port and spectrum analyzer. With the offset compensation, the spectrum analyzer reading level is exactly the EUT RF output level.

The spectrum analyzer offset is derived from RF cable loss.

Offset = RF cable loss.

Following shows an offset computation example with cable loss 8.70 dB.

Example :

$$\begin{aligned} \text{Offset(dB)} &= \text{RF cable loss(dB)}. \\ &= 8.70 \text{ (dB)} \end{aligned}$$

2.5 Frequency List of Low/Middle/High Channels

5G n77 Channel and Frequency List (SCS30kHz)				
BW [MHz]	Channel/Frequency(MHz)	Lowest	Middle	Highest
100	Channel	-	633334	-
	Frequency	-	3500.01	-
90	Channel	633000	633334	633666
	Frequency	3495	3500.01	3504.99
80	Channel	632668	633334	634000
	Frequency	3490.02	3500.01	3510
60	Channel	632000	633334	634666
	Frequency	3480	3500.01	3519.99
50	Channel	631668	633334	635000
	Frequency	3475.02	3500.01	3525
40	Channel	631334	633334	635332
	Frequency	3470.01	3500.01	3529.98
20	Channel	630668	633334	636000
	Frequency	3460.02	3500.01	3540
15	Channel	630500	633334	636166
	Frequency	3457.5	3500.01	3542.49
10	Channel	630334	633334	636332
	Frequency	3455.01	3500.01	3544.98

5G n77 Channel and Frequency List (SCS15kHz)				
BW [MHz]	Channel/Frequency(MHz)	Lowest	Middle	Highest
50	Channel	631667	633334	635000
	Frequency	3475.005	3500.01	3525
40	Channel	631334	633334	635333
	Frequency	3470.01	3500.01	3529.995
20	Channel	630667	633334	636000
	Frequency	3460.005	3500.01	3540
15	Channel	630500	633334	636166
	Frequency	3457.5	3500.01	3542.49
10	Channel	630334	633334	636333
	Frequency	3455.01	3500.01	3544.995

5G n78 Channel and Frequency List (SCS30kHz)				
BW [MHz]	Channel/Frequency(MHz)	Lowest	Middle	Highest
100	Channel	-	633334	-
	Frequency	-	3500.01	-
90	Channel	633000	633334	633666
	Frequency	3495	3500.01	3504.99
80	Channel	632668	633334	634000
	Frequency	3490.02	3500.01	3510
60	Channel	632000	633334	634666
	Frequency	3480	3500.01	3519.99
50	Channel	631668	633334	635000
	Frequency	3475.02	3500.01	3525
40	Channel	631334	633334	635332
	Frequency	3470.01	3500.01	3529.98
20	Channel	630668	633334	636000
	Frequency	3460.02	3500.01	3540
15	Channel	630500	633334	636166
	Frequency	3457.50	3500.01	3542.49
10	Channel	630334	633334	636332
	Frequency	3455.01	3500.01	3544.98

5G n78 Channel and Frequency List (SCS15kHz)				
BW [MHz]	Channel/Frequency(MHz)	Lowest	Middle	Highest
50	Channel	631667	633334	635000
	Frequency	3475.005	3500.01	3525
40	Channel	631334	633334	635333
	Frequency	3470.01	3500.01	3529.995
20	Channel	630667	633334	636000
	Frequency	3460.005	3500.01	3540
15	Channel	630500	633334	636166
	Frequency	3457.50	3500.01	3542.49
10	Channel	630334	633334	636333
	Frequency	3455.01	3500.01	3544.995

3 Conducted Test Items

3.1 Measuring Instruments

See list of measuring instruments of this test report.

3.2 Test Setup

3.2.1 Conducted Output Power

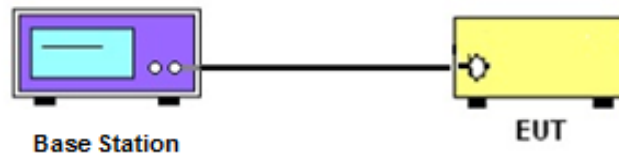

3.2.2 Peak-to-Average Ratio, Occupied / 26dB Bandwidth ,Band-Edge and Conducted Spurious Emission

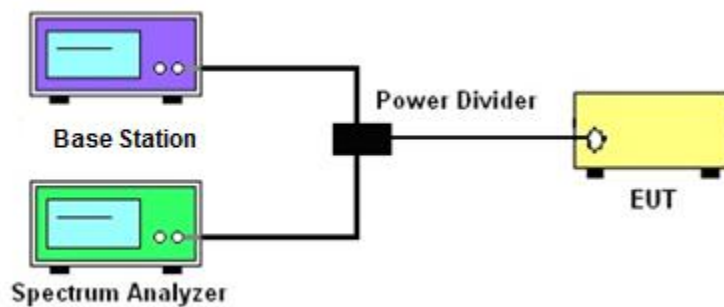

3.2.3 Frequency Stability

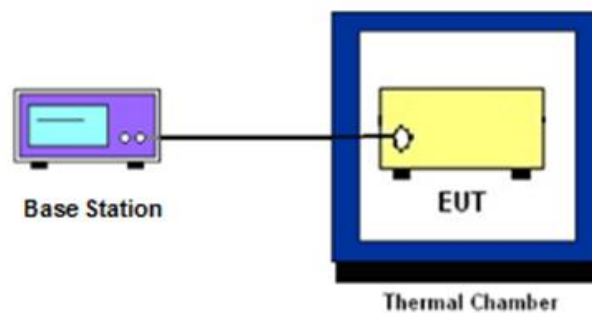

3.3 Test Result of Conducted Test

Please refer to Appendix A.

3.4 Conducted Output Power Measurement

3.4.1 Description of the Conducted Output Power Measurement

A base station simulator was used to establish communication with the EUT. Its parameters were set to transmit the maximum power on the EUT. The measured power in the radio frequency on the transmitter output terminals shall be reported.

3.4.2 Test Procedures

1. The testing follows ANSI C63.26 Section 5.2
2. The transmitter output port was connected to the system simulator.
3. Set EUT at maximum power through the system simulator.
4. Select lowest, middle, and highest channels for each band and different modulation.
5. Measure and record the power level from the system simulator.

3.5 Peak-to-Average Ratio

3.5.1 Description of the PAR Measurement

Power Complementary Cumulative Distribution Function (CCDF) curves provide a means for characterizing the power peaks of a digitally modulated signal on a statistical basis. A CCDF curve depicts the probability of the peak signal amplitude exceeding the average power level. Most contemporary measurement instrumentation include the capability to produce CCDF curves for an input signal provided that the instrument's resolution bandwidth can be set wide enough to accommodate the entire input signal bandwidth. In measuring transmissions in this band using an average power technique, the peak-to-average ratio (PAR) of the transmission may not exceed 13 dB.

3.5.2 Test Procedures

1. The testing follows ANSI C63.26 Section 5.2.3.4 (CCDF).
2. The EUT was connected to spectrum and system simulator via a power divider.
3. Set the CCDF (Complementary Cumulative Distribution Function) option in spectrum analyzer.
4. The highest RF powers were measured and recorded the maximum PAPR level associated with a probability of 0.1 %.
5. Record the deviation as Peak to Average Ratio.

3.6 EIRP

3.6.1 Description of EIRP Limit

§ 27.50 (k)(3)

Mobile devices are limited to 1Watt (30 dBm) EIRP. Mobile devices operating in these bands must employ a means for limiting power to the minimum necessary for successful communications

3.6.2 Test Procedures

1. According to KDB 412172 D01 Power Approach,
2. $EIRP = P_T + G_T - L_C$, $ERP = EIRP - 2.15$, where
 P_T = transmitter output power in dBm
 G_T = gain of the transmitting antenna in dBi
 L_C = signal attenuation in the connecting cable between the transmitter and antenna in dB

3.7 Occupied Bandwidth

3.7.1 Description of Occupied Bandwidth Measurement

The occupied bandwidth is the width of a frequency band such that, below the lower and above the upper frequency limits, the mean powers emitted are each equal to a specified percentage 0.5% of the total mean transmitted power.

The 26 dB emission bandwidth is defined as the frequency range between two points, one above and one below the carrier frequency, at which the spectral density of the emission is attenuated 26 dB below the maximum in-band spectral density of the modulated signal. Spectral density (power per unit bandwidth) is to be measured with a detector of resolution bandwidth equal to approximately 1.0% of the emission bandwidth.

3.7.2 Test Procedures

1. The testing follows ANSI C63.26 Section 5.4
2. The EUT was connected to spectrum analyzer and system simulator via a power divider.
3. The spectrum analyzer center frequency is set to the nominal EUT channel center frequency. The span range for the spectrum analyzer shall be between two and five times the anticipated OBW.
4. The nominal resolution bandwidth (RBW) shall be in the range of 1 to 5 % of the anticipated OBW, and the VBW shall be at least 3 times the RBW.
5. Set the detection mode to peak, and the trace mode to max hold.
6. Determine the reference value: Set the EUT to transmit a modulated signal. Allow the trace to stabilize. Set the spectrum analyzer marker to the highest level of the displayed trace.
(this is the reference value)
7. Determine the “-26 dB down amplitude” as equal to (Reference Value – X).
8. Place two markers, one at the lowest and the other at the highest frequency of the envelope of the spectral display such that each marker is at or slightly below the “-X dB down amplitude” determined in step 6. If a marker is below this “-X dB down amplitude” value it shall be placed as close as possible to this value. The OBW is the positive frequency difference between the two markers.
9. Use the 99 % power bandwidth function of the spectrum analyzer and report the measured bandwidth.

3.8 Conducted Band Edge Measurement

3.8.1 Description of Conducted Band Edge Measurement

§ 27.53 (n)(2)

For mobile operations in the 3450-3550 MHz band, the conducted power of any emission outside the licensee's authorized bandwidth shall not exceed -13 dBm/MHz.

Compliance with this paragraph is based on the use of measurement instrumentation employing a resolution bandwidth of 1 megahertz or greater. However, in the 1 megahertz bands immediately outside and adjacent to the licensee's frequency block, a resolution bandwidth of at least one percent of the emission bandwidth of the fundamental emission of the transmitter may be employed, but limited to a maximum of 200 kHz. In the bands between 1 and 5 MHz removed from the licensee's frequency block, the minimum resolution bandwidth for the measurement shall be 500 kHz.

3.8.2 Test Procedures

1. The testing follows ANSI C63.26 section 5.7
2. The EUT was connected to spectrum analyzer and system simulator via a power divider.
3. The band edges of low and high channels for the highest RF powers were measured.
4. Set RBW \geq 1% EBW but limited to a maximum of 200 kHz in the 1MHz band immediately outside and adjacent to the band edge.
5. Beyond the 1 MHz and 5 MHz removed from the band edge, set RBW \geq 500KHz.
6. Beyond the 5 MHz removed from the band edge, set RBW = 1MHz.
7. Set spectrum analyzer with RMS detector.
8. The RF fundamental frequency should be excluded against the limit line in the operating frequency band.
9. Checked that all the results comply with the emission limit line.

3.9 Conducted Spurious Emission Measurement

3.9.1 Description of Conducted Spurious Emission Measurement

The power of any emission outside of the authorized operating frequency ranges shall not exceed -13 dBm/MHz.

It is measured by means of a calibrated spectrum analyzer and scanned from 30MHz up to a frequency including its 10th harmonic.

3.9.2 Test Procedures

1. The testing follows ANSI C63.26 section 5.7
2. The EUT was connected to spectrum analyzer and system simulator via a power divider.
3. The RF output of EUT was connected to the spectrum analyzer by RF cable and attenuator. The path loss was compensated to the results for each measurement.
4. The middle channel for the highest RF power within the transmitting frequency was measured.
5. The conducted spurious emission for the whole frequency range was taken.
6. Make the measurement with the spectrum analyzer's RBW = 1MHz, VBW = 3MHz.
7. Set spectrum analyzer with RMS detector.
8. Taking the record of maximum spurious emission.
9. The RF fundamental frequency should be excluded against the limit line in the operating frequency band.
10. Checked that all the results comply with the emission limit line.

3.10 Frequency Stability Measurement

3.10.1 Description of Frequency Stability Measurement

The frequency stability shall be measured by variation of ambient temperature and variation of primary supply voltage to ensure that the fundamental emission stays within the authorized frequency block.

3.10.2 Test Procedures for Temperature Variation

1. The testing follows ANSI C63.26 section 5.6.4
2. The EUT was set up in the thermal chamber and connected with the system simulator.
3. With power OFF, the temperature was decreased to -30°C and the EUT was stabilized before testing. Power was applied and the maximum change in frequency was recorded within one minute.
4. With power OFF, the temperature was raised in 10°C step up to 50°C . The EUT was stabilized at each step for at least half an hour. Power was applied and the maximum frequency change was recorded within one minute.

3.10.3 Test Procedures for Voltage Variation

1. The testing follows ANSI C63.26 section 5.6.5.
2. The EUT was placed in a temperature chamber at $20\pm 5^{\circ}\text{C}$ and connected with the system simulator.
3. The power supply voltage to the EUT was varied from 85% to 115% of the nominal value for other than hand carried battery equipment.
4. For hand carried, battery powered equipment, reduce the primary ac or dc supply voltage to the battery operating end point, which shall be specified by the manufacturer.
5. The variation in frequency was measured for the worst case.

4 Radiated Test Items

4.1 Measuring Instruments

See list of measuring instruments of this test report.

4.2 Test Setup

4.2.1 For radiated test below 30MHz

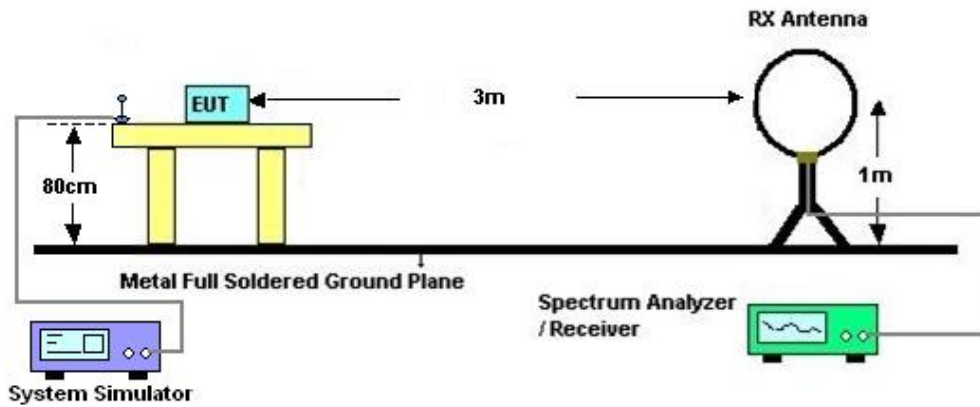

4.2.2 For radiated test from 30MHz to 1GHz

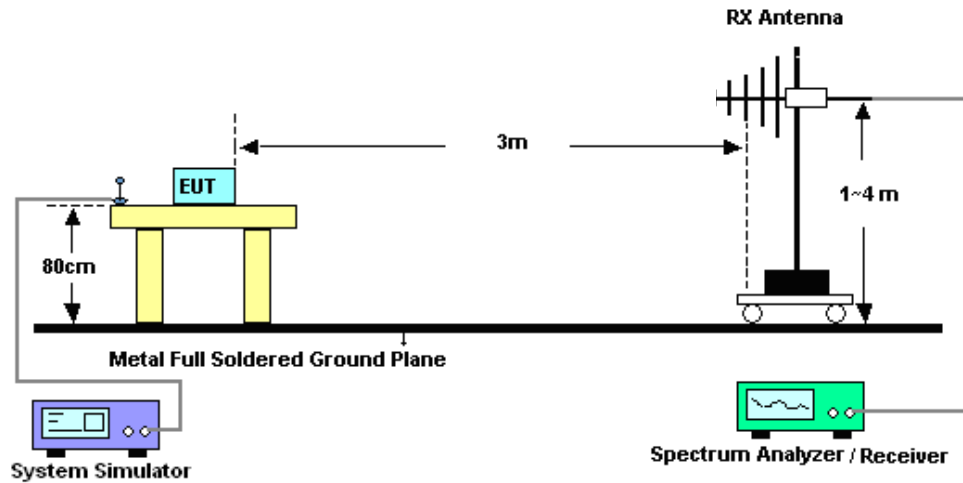

4.2.3 For radiated test above 1GHz

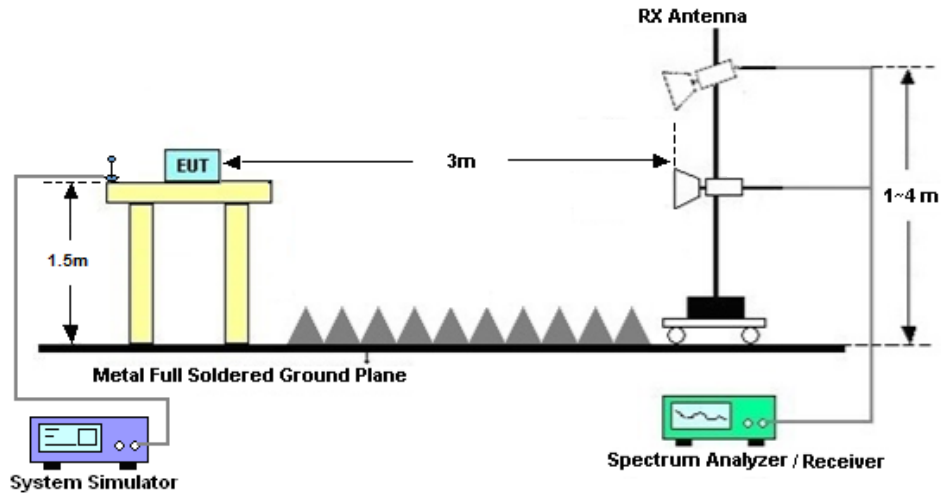

4.3 Test Result of Radiated Test

The low frequency, which started from 9 kHz to 30MHz, was pre-scanned and the result which was 20dB lower than the limit line was not reported.

Please refer to Appendix B.

4.4 Radiated Spurious Emission Measurement

4.4.1 Description of Radiated Spurious Emission

The radiated spurious emission was measured by substitution method according to ANSI/TIA-603-E. The power of any emission outside of the authorized operating frequency ranges shall not exceed -13 dBm/MHz.

The spectrum is scanned from 30 MHz up to a frequency including its 10th harmonic.

4.4.2 Test Procedures

1. The testing follows ANSI C63.26 Section 5.5
2. The EUT was placed on a turntable with 0.8 meter height for frequency below 1GHz and 1.5 meter height for frequency above 1GHz respectively above ground.
3. The EUT was set 3 meters from the receiving antenna mounted on the antenna tower.
4. The table was rotated 360 degrees to determine the position of the highest spurious emission.
5. The height of the receiving antenna is varied between 1m to 4m to search the maximum spurious emission for both horizontal and vertical polarizations.
6. During the measurement, the system simulator parameters were set to force the EUT transmitting at maximum output power.
7. Make the measurement with the spectrum analyzer's RBW = 1MHz, VBW = 3MHz, taking the record of maximum spurious emission.
8. A horn antenna was substituted in place of the EUT and was driven by a signal generator.
9. Tune the output power of signal generator to the same emission level with EUT maximum spurious emission.
$$\text{EIRP (dBm)} = \text{S.G. Power} - \text{Tx Cable Loss} + \text{Tx Antenna Gain}$$
$$\text{ERP (dBm)} = \text{EIRP} - 2.15$$
10. The RF fundamental frequency should be excluded against the limit line in the operating frequency band.



5 List of Measuring Equipment

Instrument	Manufacturer	Model No.	Serial No.	Characteristics	Calibration Date	Test Date	Due Date	Remark
Spectrum Analyzer	R&S	FSV40	101078	10Hz~40GHz	Apr. 07, 2022	Nov. 16, 2022~ Nov. 28, 2022	Apr. 06, 2023	Conducted (TH01-SZ)
Power Divider	TOJOIN	PS-2SM-04 265	60.06.020.007 7	0.4GHz~26.5GHz	Dec. 25, 2021	Nov. 16, 2022~ Nov. 28, 2022	Dec. 24, 2022	Conducted (TH01-SZ)
Thermal Chamber	Ten Billion Hongzhangroup	LP-150U	H2014081803	-40~+150°C	Jul. 07, 2022	Nov. 16, 2022~ Nov. 28, 2022	Jul. 06, 2023	Conducted (TH01-SZ)
EXA Spectrum Analyzer	KEYSIGHT	N9010A	MY55150213	10Hz~44GHz	Jul. 07, 2022	Dec. 07, 2022	Jul. 06, 2023	Radiation (03CH03-SZ)
Loop Antenna	R&S	HFH2-Z2	100354	9kHz~30MHz	Jul. 28, 2022	Dec. 07, 2022	Jul. 27, 2024	Radiation (03CH03-SZ)
Bilog Antenna	TeseQ	CBL6112D	35407	30MHz~2GHz	Oct. 19, 2022	Dec. 07, 2022	Oct. 18, 2023	Radiation (03CH03-SZ)
Double Ridge Horn Antenna	ETS-Lindgren	3117	00119436	1GHz~18GHz	Jul. 07, 2022	Dec. 07, 2022	Jul. 06, 2023	Radiation (03CH03-SZ)
HF Amplifier	MITEQ	TTA1840-35 -HG	1871923	18GHz~40GHz	Jul. 07, 2022	Dec. 07, 2022	Jul. 06, 2023	Radiation (03CH03-SZ)
SHF-EHF Horn	com-power	AH-840	101071	18Ghz~40GHz	Apr. 10, 2022	Dec. 07, 2022	Apr. 09, 2023	Radiation (03CH03-SZ)
LF Amplifier	Burgeon	BPA-530	102211	0.01~3000Mhz	Oct. 19, 2022	Dec. 07, 2022	Oct. 18, 2023	Radiation (03CH03-SZ)
HF Amplifier	KEYSIGHT	83017A	MY53270105	0.5GHz~26.5Ghz	Oct. 19, 2022	Dec. 07, 2022	Oct. 18, 2023	Radiation (03CH03-SZ)
AC Power Source	Chroma	61601	616010003043	N/A	Nov. 10, 2022	Dec. 07, 2022	Nov. 09, 2023	Radiation (03CH03-SZ)
Turn Table	Chaintek	T-200	N/A	0~360 degree	NCR	Dec. 07, 2022	NCR	Radiation (03CH03-SZ)
Antenna Mast	Chaintek	MBS-400	N/A	1 m~4 m	NCR	Dec. 07, 2022	NCR	Radiation (03CH03-SZ)

NCR: No Calibration Required

6 Uncertainty of Evaluation

The measurement uncertainties shown below were calculated in accordance with the requirements of ANSI 63.26-2015. All the measurement uncertainty value were shown with a coverage K=2 to indicate 95% level of confidence. The measurement data show herein meets or exceeds the CISPR measurement uncertainty values specified in CISPR 16-4-2 and can be compared directly to specified limit to determine compliance.

Uncertainty of Conducted Measurement

Test Item	Uncertainty
Conducted Power	±1.34 dB
Conducted Emissions	±1.34 dB
Occupied Channel Bandwidth	±0.13 %

Uncertainty of Radiated Emission Measurement (30 MHz ~ 1000 MHz)

Measuring Uncertainty for a Level of Confidence of 95% (U = 2Uc(y))	3.0dB
---	-------

Uncertainty of Radiated Emission Measurement (1 GHz ~ 18 GHz)

Measuring Uncertainty for a Level of Confidence of 95% (U = 2Uc(y))	3.6dB
---	-------

Uncertainty of Radiated Emission Measurement (18 GHz ~ 40 GHz)

Measuring Uncertainty for a Level of Confidence of 95% (U = 2Uc(y))	3.8dB
---	-------

----- THE END -----



Appendix A. Test Results of Conducted Test

Test Engineer :	Jung Kuo	Temperature :	22~23°C
		Relative Humidity :	40~42%

FR1 N77(ANT6)

Transmitter Conducted Output Power And EIRP, (G_T - L_C)=-1.4dB

NR Band	SCS (kHz)	Bandwidth (MHz)	Arfcn	Freq (MHz)	Modulation	RB	Conducted Power(dBm)	EIRP (dBm)	EIRP (W)
77	15	10	630334	3455.01	DFT-s-OFDM QPSK	1@1	22.59	21.19	0.1315
77	15	10	630334	3455.01	DFT-s-OFDM 16 QAM	1@1	21.61	20.21	0.1050
77	15	10	633334	3500.01	DFT-s-OFDM QPSK	1@1	21.54	20.14	0.1033
77	15	10	633334	3500.01	DFT-s-OFDM 16 QAM	1@1	20.71	19.31	0.0853
77	15	10	636333	3544.995	DFT-s-OFDM QPSK	1@1	21.98	20.58	0.1143
77	15	10	636333	3544.995	DFT-s-OFDM 16 QAM	1@1	20.95	19.55	0.0902
77	15	15	630500	3457.5	DFT-s-OFDM QPSK	1@1	22.73	21.33	0.1358
77	15	15	630500	3457.5	DFT-s-OFDM 16 QAM	1@1	21.97	20.57	0.1140
77	15	15	633334	3500.01	DFT-s-OFDM QPSK	1@1	21.73	20.33	0.1079
77	15	15	633334	3500.01	DFT-s-OFDM 16 QAM	1@1	20.89	19.49	0.0889
77	15	15	636166	3542.49	DFT-s-OFDM QPSK	1@1	22	20.6	0.1148
77	15	15	636166	3542.49	DFT-s-OFDM 16 QAM	1@1	20.99	19.59	0.0910
77	15	20	630667	3460.005	DFT-s-OFDM QPSK	1@1	22.71	21.31	0.1352
77	15	20	630667	3460.005	DFT-s-OFDM 16 QAM	1@1	21.71	20.31	0.1074
77	15	20	633334	3500.01	DFT-s-OFDM QPSK	1@1	21.73	20.33	0.1079
77	15	20	633334	3500.01	DFT-s-OFDM 16 QAM	1@1	20.87	19.47	0.0885
77	15	20	636000	3540	DFT-s-OFDM QPSK	1@1	21.9	20.5	0.1122
77	15	20	636000	3540	DFT-s-OFDM 16 QAM	1@1	21.14	19.74	0.0942
77	15	40	631334	3470.01	DFT-s-OFDM QPSK	1@1	22.33	20.93	0.1239
77	15	40	631334	3470.01	DFT-s-OFDM 16 QAM	1@1	21.35	19.95	0.0989
77	15	40	633334	3500.01	DFT-s-OFDM QPSK	1@1	21.59	20.19	0.1045
77	15	40	633334	3500.01	DFT-s-OFDM 16 QAM	1@1	20.85	19.45	0.0881
77	15	40	635333	3529.995	DFT-s-OFDM QPSK	1@1	21.35	19.95	0.0989
77	15	40	635333	3529.995	DFT-s-OFDM 16 QAM	1@1	20.62	19.22	0.0836
77	15	50	631667	3475.005	DFT-s-OFDM PI/2 BPSK	135@67	22.75	21.35	0.1365
77	15	50	631667	3475.005	DFT-s-OFDM PI/2 BPSK	1@1	22.61	21.21	0.1321
77	15	50	631667	3475.005	DFT-s-OFDM PI/2 BPSK	1@268	22.26	20.86	0.1219
77	15	50	631667	3475.005	DFT-s-OFDM QPSK	135@67	22.77	21.37	0.1371
77	15	50	631667	3475.005	DFT-s-OFDM QPSK	1@1	22.64	21.24	0.1330

77	15	50	631667	3475.005	DFT-s-OFDM QPSK	1@268	22.33	20.93	0.1239
77	15	50	631667	3475.005	DFT-s-OFDM 16 QAM	135@67	21.75	20.35	0.1084
77	15	50	631667	3475.005	DFT-s-OFDM 16 QAM	1@1	21.55	20.15	0.1035
77	15	50	631667	3475.005	DFT-s-OFDM 16 QAM	1@268	21.24	19.84	0.0964
77	15	50	631667	3475.005	DFT-s-OFDM 64 QAM	135@67	20.24	18.84	0.0766
77	15	50	631667	3475.005	DFT-s-OFDM 64 QAM	1@1	20.12	18.72	0.0745
77	15	50	631667	3475.005	DFT-s-OFDM 64 QAM	1@268	19.84	18.44	0.0698
77	15	50	631667	3475.005	DFT-s-OFDM 256 QAM	135@67	18.38	16.98	0.0499
77	15	50	631667	3475.005	DFT-s-OFDM 256 QAM	1@1	18.22	16.82	0.0481
77	15	50	631667	3475.005	DFT-s-OFDM 256 QAM	1@268	18.03	16.63	0.0460
77	15	50	631667	3475.005	CP-OFDM QPSK	135@67	21.24	19.84	0.0964
77	15	50	631667	3475.005	CP-OFDM QPSK	1@1	21.17	19.77	0.0948
77	15	50	631667	3475.005	CP-OFDM QPSK	1@268	20.93	19.53	0.0897
77	15	50	633334	3500.01	DFT-s-OFDM PI/2 BPSK	135@67	22.67	21.27	0.1340
77	15	50	633334	3500.01	DFT-s-OFDM PI/2 BPSK	1@1	22.55	21.15	0.1303
77	15	50	633334	3500.01	DFT-s-OFDM PI/2 BPSK	1@268	22.3	20.9	0.1230
77	15	50	633334	3500.01	DFT-s-OFDM QPSK	135@67	22.69	21.29	0.1346
77	15	50	633334	3500.01	DFT-s-OFDM QPSK	1@1	22.59	21.19	0.1315
77	15	50	633334	3500.01	DFT-s-OFDM QPSK	1@268	22.33	20.93	0.1239
77	15	50	633334	3500.01	DFT-s-OFDM 16 QAM	135@67	21.68	20.28	0.1067
77	15	50	633334	3500.01	DFT-s-OFDM 16 QAM	1@1	21.52	20.12	0.1028
77	15	50	633334	3500.01	DFT-s-OFDM 16 QAM	1@268	21.24	19.84	0.0964
77	15	50	633334	3500.01	DFT-s-OFDM 64 QAM	135@67	20.14	18.74	0.0748
77	15	50	633334	3500.01	DFT-s-OFDM 64 QAM	1@1	20.12	18.72	0.0745
77	15	50	633334	3500.01	DFT-s-OFDM 64 QAM	1@268	19.89	18.49	0.0706
77	15	50	633334	3500.01	DFT-s-OFDM 256 QAM	135@67	18.29	16.89	0.0489
77	15	50	633334	3500.01	DFT-s-OFDM 256 QAM	1@1	18.3	16.9	0.0490
77	15	50	633334	3500.01	DFT-s-OFDM 256 QAM	1@268	17.98	16.58	0.0455
77	15	50	633334	3500.01	CP-OFDM QPSK	135@67	21.16	19.76	0.0946
77	15	50	633334	3500.01	CP-OFDM QPSK	1@1	21.14	19.74	0.0942
77	15	50	633334	3500.01	CP-OFDM QPSK	1@268	20.96	19.56	0.0904
77	15	50	635000	3525	DFT-s-OFDM PI/2 BPSK	135@67	22.67	21.27	0.1340
77	15	50	635000	3525	DFT-s-OFDM PI/2 BPSK	1@1	22.43	21.03	0.1268
77	15	50	635000	3525	DFT-s-OFDM PI/2 BPSK	1@268	22.28	20.88	0.1225
77	15	50	635000	3525	DFT-s-OFDM QPSK	135@67	22.72	21.32	0.1355

77	15	50	635000	3525	DFT-s-OFDM QPSK	1@1	22.46	21.06	0.1276
77	15	50	635000	3525	DFT-s-OFDM QPSK	1@268	22.3	20.9	0.1230
77	15	50	635000	3525	DFT-s-OFDM 16 QAM	135@67	21.69	20.29	0.1069
77	15	50	635000	3525	DFT-s-OFDM 16 QAM	1@1	21.38	19.98	0.0995
77	15	50	635000	3525	DFT-s-OFDM 16 QAM	1@268	21.23	19.83	0.0962
77	15	50	635000	3525	DFT-s-OFDM 64 QAM	135@67	20.19	18.79	0.0757
77	15	50	635000	3525	DFT-s-OFDM 64 QAM	1@1	19.99	18.59	0.0723
77	15	50	635000	3525	DFT-s-OFDM 64 QAM	1@268	19.81	18.41	0.0693
77	15	50	635000	3525	DFT-s-OFDM 256 QAM	135@67	18.32	16.92	0.0492
77	15	50	635000	3525	DFT-s-OFDM 256 QAM	1@1	18.17	16.77	0.0475
77	15	50	635000	3525	DFT-s-OFDM 256 QAM	1@268	18	16.6	0.0457
77	15	50	635000	3525	CP-OFDM QPSK	135@67	21.19	19.79	0.0953
77	15	50	635000	3525	CP-OFDM QPSK	1@1	21.05	19.65	0.0923
77	15	50	635000	3525	CP-OFDM QPSK	1@268	20.82	19.42	0.0875

FR1 N77(ANT6)

Transmitter Conducted Output Power And EIRP, (G_T - L_C)=-1.4dB

NR Band	SCS (kHz)	Bandwidth (MHz)	Arfcn	Freq (MHz)	Modulation	RB	Conducted Power(dBm)	EIRP (dBm)	EIRP (W)
77	30	10	630334	3455.01	DFT-s-OFDM QPSK	1@1	22.66	21.26	0.1337
77	30	10	630334	3455.01	DFT-s-OFDM 16 QAM	1@1	21.88	20.48	0.1117
77	30	10	633334	3500.01	DFT-s-OFDM QPSK	1@1	22.64	21.24	0.1330
77	30	10	633334	3500.01	DFT-s-OFDM 16 QAM	1@1	21.81	20.41	0.1099
77	30	10	636332	3544.98	DFT-s-OFDM QPSK	1@1	22.69	21.29	0.1346
77	30	10	636332	3544.98	DFT-s-OFDM 16 QAM	1@1	21.58	20.18	0.1042
77	30	15	630500	3457.5	DFT-s-OFDM QPSK	1@1	22.64	21.24	0.1330
77	30	15	630500	3457.5	DFT-s-OFDM 16 QAM	1@1	21.61	20.21	0.1050
77	30	15	633334	3500.01	DFT-s-OFDM QPSK	1@1	22.62	21.22	0.1324
77	30	15	633334	3500.01	DFT-s-OFDM 16 QAM	1@1	21.81	20.41	0.1099
77	30	15	636166	3542.49	DFT-s-OFDM QPSK	1@1	22.61	21.21	0.1321
77	30	15	636166	3542.49	DFT-s-OFDM 16 QAM	1@1	21.8	20.4	0.1096
77	30	20	630668	3460.02	DFT-s-OFDM QPSK	1@1	22.63	21.23	0.1327
77	30	20	630668	3460.02	DFT-s-OFDM 16 QAM	1@1	21.83	20.43	0.1104
77	30	20	633334	3500.01	DFT-s-OFDM QPSK	1@1	22.56	21.16	0.1306
77	30	20	633334	3500.01	DFT-s-OFDM 16 QAM	1@1	21.77	20.37	0.1089
77	30	20	636000	3540	DFT-s-OFDM QPSK	1@1	22.56	21.16	0.1306
77	30	20	636000	3540	DFT-s-OFDM 16 QAM	1@1	21.81	20.41	0.1099
77	30	40	631334	3470.01	DFT-s-OFDM QPSK	1@1	22.32	20.92	0.1236
77	30	40	631334	3470.01	DFT-s-OFDM 16 QAM	1@1	21.55	20.15	0.1035
77	30	40	633334	3500.01	DFT-s-OFDM QPSK	1@1	22.29	20.89	0.1227
77	30	40	633334	3500.01	DFT-s-OFDM 16 QAM	1@1	21.5	20.1	0.1023
77	30	40	635332	3529.98	DFT-s-OFDM QPSK	1@1	22.26	20.86	0.1219
77	30	40	635332	3529.98	DFT-s-OFDM 16 QAM	1@1	21.25	19.85	0.0966
77	30	50	631668	3475.02	DFT-s-OFDM QPSK	1@1	22.61	21.21	0.1321
77	30	50	631668	3475.02	DFT-s-OFDM 16 QAM	1@1	21.52	20.12	0.1028
77	30	50	633334	3500.01	DFT-s-OFDM QPSK	1@1	22.55	21.15	0.1303
77	30	50	633334	3500.01	DFT-s-OFDM 16 QAM	1@1	21.78	20.38	0.1091
77	30	50	635000	3525	DFT-s-OFDM QPSK	1@1	22.55	21.15	0.1303

77	30	50	635000	3525	DFT-s-OFDM 16 QAM	1@1	21.71	20.31	0.1074
77	30	60	632000	3480	DFT-s-OFDM QPSK	1@1	22.47	21.07	0.1279
77	30	60	632000	3480	DFT-s-OFDM 16 QAM	1@1	21.7	20.3	0.1072
77	30	60	633334	3500.01	DFT-s-OFDM QPSK	1@1	22.45	21.05	0.1274
77	30	60	633334	3500.01	DFT-s-OFDM 16 QAM	1@1	21.66	20.26	0.1062
77	30	60	634666	3519.99	DFT-s-OFDM QPSK	1@1	22.45	21.05	0.1274
77	30	60	634666	3519.99	DFT-s-OFDM 16 QAM	1@1	21.66	20.26	0.1062
77	30	80	632668	3490.02	DFT-s-OFDM QPSK	1@1	22.32	20.92	0.1236
77	30	80	632668	3490.02	DFT-s-OFDM 16 QAM	1@1	21.51	20.11	0.1026
77	30	80	633334	3500.01	DFT-s-OFDM QPSK	1@1	22.31	20.91	0.1233
77	30	80	633334	3500.01	DFT-s-OFDM 16 QAM	1@1	21.5	20.1	0.1023
77	30	80	634000	3510	DFT-s-OFDM QPSK	1@1	22.32	20.92	0.1236
77	30	80	634000	3510	DFT-s-OFDM 16 QAM	1@1	21.5	20.1	0.1023
77	30	90	633000	3495	DFT-s-OFDM QPSK	1@1	22.16	20.76	0.1191
77	30	90	633000	3495	DFT-s-OFDM 16 QAM	1@1	21.2	19.8	0.0955
77	30	90	633334	3500.01	DFT-s-OFDM QPSK	1@1	22.17	20.77	0.1194
77	30	90	633334	3500.01	DFT-s-OFDM 16 QAM	1@1	21.46	20.06	0.1014
77	30	90	633666	3504.99	DFT-s-OFDM QPSK	1@1	22.17	20.77	0.1194
77	30	90	633666	3504.99	DFT-s-OFDM 16 QAM	1@1	21.47	20.07	0.1016
77	30	100	633334	3500.01	DFT-s-OFDM PI/2 BPSK	135@67	22.73	21.33	0.1358
77	30	100	633334	3500.01	DFT-s-OFDM PI/2 BPSK	1@1	22.08	20.68	0.1169
77	30	100	633334	3500.01	DFT-s-OFDM PI/2 BPSK	1@271	21.67	20.27	0.1064
77	30	100	633334	3500.01	DFT-s-OFDM QPSK	135@67	22.71	21.31	0.1352
77	30	100	633334	3500.01	DFT-s-OFDM QPSK	1@1	22.09	20.69	0.1172
77	30	100	633334	3500.01	DFT-s-OFDM QPSK	1@271	21.59	20.19	0.1045
77	30	100	633334	3500.01	DFT-s-OFDM 16 QAM	135@67	21.72	20.32	0.1076
77	30	100	633334	3500.01	DFT-s-OFDM 16 QAM	1@1	21.26	19.86	0.0968
77	30	100	633334	3500.01	DFT-s-OFDM 16 QAM	1@271	20.77	19.37	0.0865
77	30	100	633334	3500.01	DFT-s-OFDM 64 QAM	135@67	20.23	18.83	0.0764
77	30	100	633334	3500.01	DFT-s-OFDM 64 QAM	1@1	19.37	17.97	0.0627
77	30	100	633334	3500.01	DFT-s-OFDM 64 QAM	1@271	18.96	17.56	0.0570
77	30	100	633334	3500.01	DFT-s-OFDM 256 QAM	135@67	18.37	16.97	0.0498
77	30	100	633334	3500.01	DFT-s-OFDM 256 QAM	1@1	17.92	16.52	0.0449
77	30	100	633334	3500.01	DFT-s-OFDM 256 QAM	1@271	17.61	16.21	0.0418
77	30	100	633334	3500.01	CP-OFDM QPSK	137@68	21.18	19.78	0.0951

77	30	100	633334	3500.01	CP-OFDM QPSK	1@1	20.52	19.12	0.0817
77	30	100	633334	3500.01	CP-OFDM QPSK	1@271	20.13	18.73	0.0746

FR1 N78(ANT6)

Transmitter Conducted Output Power And EIRP, ($G_T - L_C$)=-1.4dB

NR Band	SCS (kHz)	Bandwidth (MHz)	Arfcn	Freq (MHz)	Modulation	RB	Conducted Power(dBm)	EIRP (dBm)	EIRP (W)
78	15	10	630334	3455.01	DFT-s-OFDM QPSK	1@1	25.57	24.17	0.2612
78	15	10	630334	3455.01	DFT-s-OFDM 16 QAM	1@1	24.59	23.19	0.2084
78	15	10	633334	3500.01	DFT-s-OFDM QPSK	1@1	25.38	23.98	0.2500
78	15	10	633334	3500.01	DFT-s-OFDM 16 QAM	1@1	24.41	23.01	0.2000
78	15	10	636333	3544.995	DFT-s-OFDM QPSK	1@1	25.33	23.93	0.2472
78	15	10	636333	3544.995	DFT-s-OFDM 16 QAM	1@1	24.4	23	0.1995
78	15	15	630500	3457.5	DFT-s-OFDM QPSK	1@1	25.7	24.3	0.2692
78	15	15	630500	3457.5	DFT-s-OFDM 16 QAM	1@1	24.8	23.4	0.2188
78	15	15	633334	3500.01	DFT-s-OFDM QPSK	1@1	25.5	24.1	0.2570
78	15	15	633334	3500.01	DFT-s-OFDM 16 QAM	1@1	24.64	23.24	0.2109
78	15	15	636166	3542.49	DFT-s-OFDM QPSK	1@1	25.48	24.08	0.2559
78	15	15	636166	3542.49	DFT-s-OFDM 16 QAM	1@1	24.55	23.15	0.2065
78	15	20	630667	3460.005	DFT-s-OFDM QPSK	1@1	25.69	24.29	0.2685
78	15	20	630667	3460.005	DFT-s-OFDM 16 QAM	1@1	24.77	23.37	0.2173
78	15	20	633334	3500.01	DFT-s-OFDM QPSK	1@1	25.46	24.06	0.2547
78	15	20	633334	3500.01	DFT-s-OFDM 16 QAM	1@1	24.54	23.14	0.2061
78	15	20	636000	3540.0	DFT-s-OFDM QPSK	1@1	25.45	24.05	0.2541
78	15	20	636000	3540.0	DFT-s-OFDM 16 QAM	1@1	24.54	23.14	0.2061
78	15	40	631334	3470.01	DFT-s-OFDM QPSK	1@1	25.19	23.79	0.2393
78	15	40	631334	3470.01	DFT-s-OFDM 16 QAM	1@1	24.28	22.88	0.1941
78	15	40	633334	3500.01	DFT-s-OFDM QPSK	1@1	25.02	23.62	0.2301
78	15	40	633334	3500.01	DFT-s-OFDM 16 QAM	1@1	24.1	22.7	0.1862

78	15	40	635333	3529.995	DFT-s-OFDM QPSK	1@1	24.96	23.56	0.2270
78	15	40	635333	3529.995	DFT-s-OFDM 16 QAM	1@1	24.04	22.64	0.1837
78	15	50	631667	3475.005	DFT-s-OFDM PI/2 BPSK	135@67	25.65	24.25	0.2661
78	15	50	631667	3475.005	DFT-s-OFDM PI/2 BPSK	1@1	25.52	24.12	0.2582
78	15	50	631667	3475.005	DFT-s-OFDM PI/2 BPSK	1@268	25.18	23.78	0.2388
78	15	50	631667	3475.005	DFT-s-OFDM QPSK	135@67	25.73	24.33	0.2710
78	15	50	631667	3475.005	DFT-s-OFDM QPSK	1@1	25.54	24.14	0.2594
78	15	50	631667	3475.005	DFT-s-OFDM QPSK	1@268	25.22	23.82	0.2410
78	15	50	631667	3475.005	DFT-s-OFDM 16 QAM	135@67	24.73	23.33	0.2153
78	15	50	631667	3475.005	DFT-s-OFDM 16 QAM	1@1	24.52	23.12	0.2051
78	15	50	631667	3475.005	DFT-s-OFDM 16 QAM	1@268	24.2	22.8	0.1905
78	15	50	631667	3475.005	DFT-s-OFDM 64 QAM	135@67	23.21	21.81	0.1517
78	15	50	631667	3475.005	DFT-s-OFDM 64 QAM	1@1	23.17	21.77	0.1503
78	15	50	631667	3475.005	DFT-s-OFDM 64 QAM	1@268	22.8	21.4	0.1380
78	15	50	631667	3475.005	DFT-s-OFDM 256 QAM	135@67	21.17	19.77	0.0948
78	15	50	631667	3475.005	DFT-s-OFDM 256 QAM	1@1	21.32	19.92	0.0982
78	15	50	631667	3475.005	DFT-s-OFDM 256 QAM	1@268	20.9	19.5	0.0891
78	15	50	631667	3475.005	CP-OFDM QPSK	135@67	24.16	22.76	0.1888
78	15	50	631667	3475.005	CP-OFDM QPSK	1@1	24.12	22.72	0.1871
78	15	50	631667	3475.005	CP-OFDM QPSK	1@268	23.84	22.44	0.1754
78	15	50	633334	3500.01	DFT-s-OFDM PI/2 BPSK	135@67	25.56	24.16	0.2606
78	15	50	633334	3500.01	DFT-s-OFDM PI/2 BPSK	1@1	25.38	23.98	0.2500
78	15	50	633334	3500.01	DFT-s-OFDM PI/2 BPSK	1@268	25.21	23.81	0.2404
78	15	50	633334	3500.01	DFT-s-OFDM QPSK	135@67	25.62	24.22	0.2642
78	15	50	633334	3500.01	DFT-s-OFDM QPSK	1@1	25.4	24	0.2512
78	15	50	633334	3500.01	DFT-s-OFDM QPSK	1@268	25.22	23.82	0.2410
78	15	50	633334	3500.01	DFT-s-OFDM 16 QAM	135@67	24.69	23.29	0.2133

78	15	50	633334	3500.01	DFT-s-OFDM 16 QAM	1@1	24.39	22.99	0.1991
78	15	50	633334	3500.01	DFT-s-OFDM 16 QAM	1@268	24.18	22.78	0.1897
78	15	50	633334	3500.01	DFT-s-OFDM 64 QAM	135@67	23.17	21.77	0.1503
78	15	50	633334	3500.01	DFT-s-OFDM 64 QAM	1@1	23.03	21.63	0.1455
78	15	50	633334	3500.01	DFT-s-OFDM 64 QAM	1@268	22.79	21.39	0.1377
78	15	50	633334	3500.01	DFT-s-OFDM 256 QAM	135@67	21.12	19.72	0.0938
78	15	50	633334	3500.01	DFT-s-OFDM 256 QAM	1@1	21.22	19.82	0.0959
78	15	50	633334	3500.01	DFT-s-OFDM 256 QAM	1@268	20.95	19.55	0.0902
78	15	50	633334	3500.01	CP-OFDM QPSK	135@67	24.11	22.71	0.1866
78	15	50	633334	3500.01	CP-OFDM QPSK	1@1	24.03	22.63	0.1832
78	15	50	633334	3500.01	CP-OFDM QPSK	1@268	23.68	22.28	0.1690
78	15	50	635000	3525.0	DFT-s-OFDM PI/2 BPSK	135@67	25.6	24.2	0.2630
78	15	50	635000	3525.0	DFT-s-OFDM PI/2 BPSK	1@1	25.33	23.93	0.2472
78	15	50	635000	3525.0	DFT-s-OFDM PI/2 BPSK	1@268	25.15	23.75	0.2371
78	15	50	635000	3525.0	DFT-s-OFDM QPSK	135@67	25.61	24.21	0.2636
78	15	50	635000	3525.0	DFT-s-OFDM QPSK	1@1	25.32	23.92	0.2466
78	15	50	635000	3525.0	DFT-s-OFDM QPSK	1@268	25.16	23.76	0.2377
78	15	50	635000	3525.0	DFT-s-OFDM 16 QAM	135@67	24.65	23.25	0.2113
78	15	50	635000	3525.0	DFT-s-OFDM 16 QAM	1@1	24.34	22.94	0.1968
78	15	50	635000	3525.0	DFT-s-OFDM 16 QAM	1@268	24.12	22.72	0.1871
78	15	50	635000	3525.0	DFT-s-OFDM 64 QAM	135@67	23.12	21.72	0.1486
78	15	50	635000	3525.0	DFT-s-OFDM 64 QAM	1@1	22.93	21.53	0.1422
78	15	50	635000	3525.0	DFT-s-OFDM 64 QAM	1@268	22.68	21.28	0.1343
78	15	50	635000	3525.0	DFT-s-OFDM 256 QAM	135@67	21.08	19.68	0.0929
78	15	50	635000	3525.0	DFT-s-OFDM 256 QAM	1@1	21.06	19.66	0.0925
78	15	50	635000	3525.0	DFT-s-OFDM 256 QAM	1@268	20.82	19.42	0.0875
78	15	50	635000	3525.0	CP-OFDM QPSK	135@67	24.08	22.68	0.1854

78	15	50	635000	3525.0	CP-OFDM QPSK	1@1	23.97	22.57	0.1807
78	15	50	635000	3525.0	CP-OFDM QPSK	1@268	23.8	22.4	0.1738

Frequency Stability

NR Band	SCS (kHz)	Bandwidth (MHz)	Arfcn	Freq (MHz)	Modulation	RB	Deviation (ppm)	Verdict	Environment
78	15	20	633334	3500.01	DFT-s-OFDM QPSK	100@0	0.0069	PASS	NV
78	15	20	633334	3500.01	DFT-s-OFDM QPSK	100@0	0.0026	PASS	LV
78	15	20	633334	3500.01	DFT-s-OFDM QPSK	100@0	0.0036	PASS	HV
78	15	20	633334	3500.01	DFT-s-OFDM QPSK	100@0	0.0040	PASS	-30°C
78	15	20	633334	3500.01	DFT-s-OFDM QPSK	100@0	0.0058	PASS	-20°C
78	15	20	633334	3500.01	DFT-s-OFDM QPSK	100@0	0.0048	PASS	-10°C
78	15	20	633334	3500.01	DFT-s-OFDM QPSK	100@0	0.0067	PASS	0°C
78	15	20	633334	3500.01	DFT-s-OFDM QPSK	100@0	0.0023	PASS	10°C
78	15	20	633334	3500.01	DFT-s-OFDM QPSK	100@0	0.0069	PASS	20°C
78	15	20	633334	3500.01	DFT-s-OFDM QPSK	100@0	0.0034	PASS	30°C
78	15	20	633334	3500.01	DFT-s-OFDM QPSK	100@0	0.0025	PASS	40°C
78	15	20	633334	3500.01	DFT-s-OFDM QPSK	100@0	0.0035	PASS	50°C

Peak to Average Ratio

NR Band	SCS (kHz)	Bandwidth (MHz)	Arfcn	Freq (MHz)	Modulation	RB	Result (dB)	Limit (dB)	Verdict
78	15	20	630667	3460.005	DFT-s-OFDM PI/2 BPSK	100@0	3.98	13	PASS
78	15	20	630667	3460.005	DFT-s-OFDM PI/2 BPSK	1@0	5.23	13	PASS
78	15	20	630667	3460.005	DFT-s-OFDM QPSK	100@0	5.13	13	PASS
78	15	20	630667	3460.005	DFT-s-OFDM QPSK	1@0	6.39	13	PASS
78	15	20	633334	3500.01	DFT-s-OFDM PI/2 BPSK	100@0	3.91	13	PASS
78	15	20	633334	3500.01	DFT-s-OFDM PI/2 BPSK	1@0	4.89	13	PASS
78	15	20	633334	3500.01	DFT-s-OFDM QPSK	100@0	5.07	13	PASS
78	15	20	633334	3500.01	DFT-s-OFDM QPSK	1@0	6.48	13	PASS
78	15	20	636000	3540.0	DFT-s-OFDM PI/2 BPSK	100@0	3.83	13	PASS
78	15	20	636000	3540.0	DFT-s-OFDM PI/2 BPSK	1@0	4.86	13	PASS
78	15	20	636000	3540.0	DFT-s-OFDM QPSK	100@0	5.04	13	PASS
78	15	20	636000	3540.0	DFT-s-OFDM QPSK	1@0	5.15	13	PASS

N78(20M)_DFT-s-OFDM_PI_2-BPSK_Outer_Full_Low_CH



N78(20M)_DFT-s-OFDM_PI_2-BPSK_Edge_1RB_Left_Low_CH

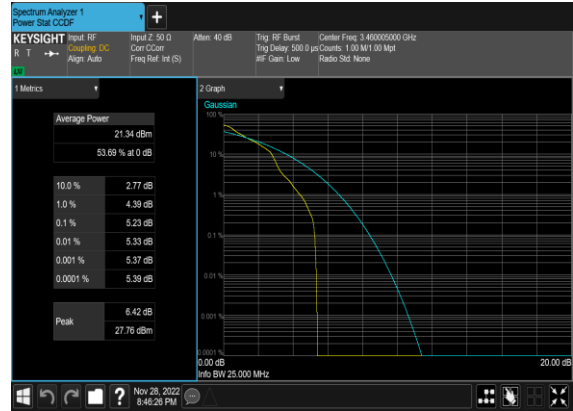

N78(20M)_DFT-s-OFDM_QPSK_Outer_Full_Low_CH

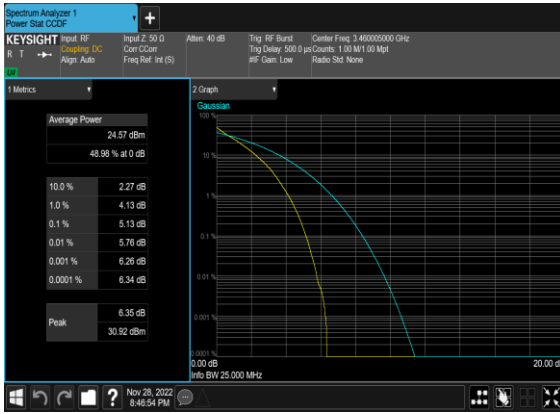

N78(20M)_DFT-s-OFDM_QPSK_Edge_1RB_Left_Low_CH



N78(20M)_DFT-s-OFDM_PI_2-BPSK_Outer_Full_Mid_CH

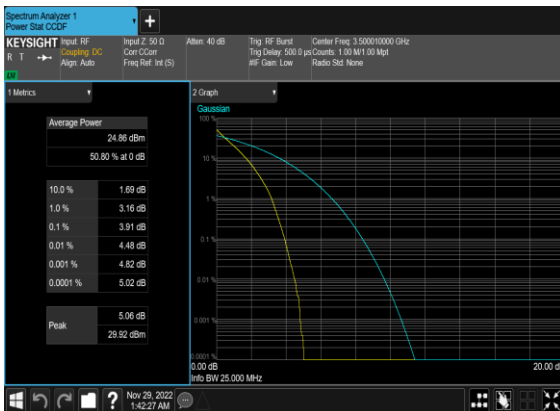

N78(20M)_DFT-s-OFDM_PI_2-BPSK_Edge_1RB_Left_Mid_CH

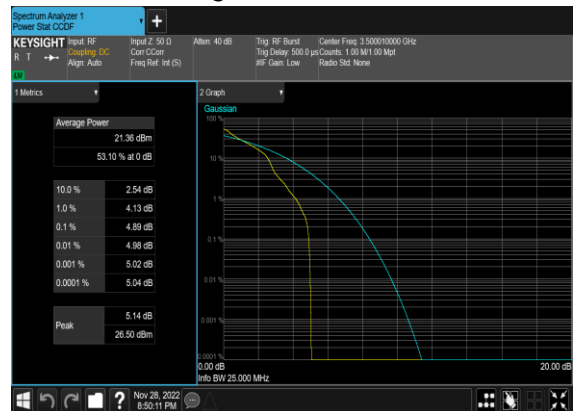

N78(20M)_DFT-s-OFDM_QPSK_Outer_Full_Mid_CH



N78(20M)_DFT-s-OFDM_QPSK_Edge_1RB_Left_Mid_CH

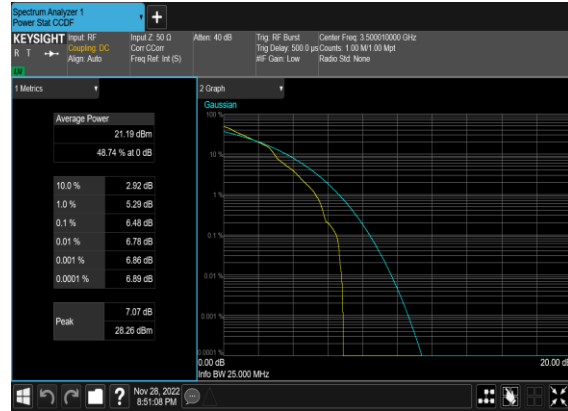

N78(20M)_DFT-s-OFDM_PI_2-BPSK_Outer_Full_High_CH



N78(20M)_DFT-s-OFDM_PI_2-BPSK_Edge_1RB_Left_High_CH



N78(20M)_DFT-s-OFDM_QPSK_Outer_Full_High_CH



N78(20M)_DFT-s-OFDM_QPSK_Edge_1RB_Left_High_CH

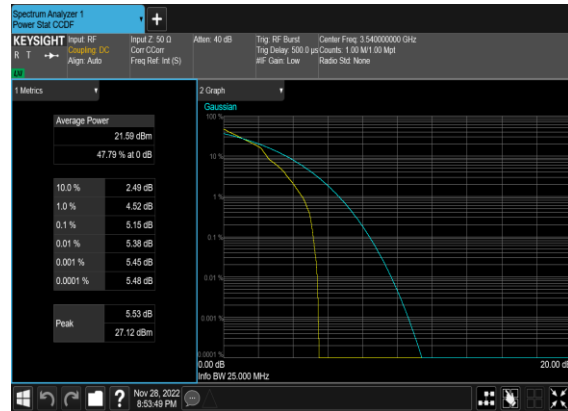

Occupied Bandwidth

NR Band	SCS (kHz)	Bandwidth (MHz)	Arfcn	Freq (MHz)	Modulation	RB	OBW (MHz)	26dB OBW (MHz)
78	15	10	633334	3500.01	DFT-s-OFDM PI/2 BPSK	50@0	8.8933	9.566
78	15	10	633334	3500.01	DFT-s-OFDM QPSK	50@0	8.8938	9.654
78	15	10	633334	3500.01	CP-OFDM QPSK	52@0	9.2786	9.839
78	15	10	633334	3500.01	CP-OFDM 16 QAM	52@0	9.2754	9.822
78	15	10	633334	3500.01	CP-OFDM 64 QAM	52@0	9.2665	9.811
78	15	10	633334	3500.01	CP-OFDM 256 QAM	52@0	9.2694	9.945
78	15	15	633334	3500.01	DFT-s-OFDM PI/2 BPSK	75@0	13.408	14.23
78	15	15	633334	3500.01	DFT-s-OFDM QPSK	75@0	13.397	14.14
78	15	15	633334	3500.01	CP-OFDM QPSK	79@0	14.076	14.71
78	15	15	633334	3500.01	CP-OFDM 16 QAM	79@0	14.101	14.77
78	15	15	633334	3500.01	CP-OFDM 64 QAM	79@0	14.103	14.73
78	15	15	633334	3500.01	CP-OFDM 256 QAM	79@0	14.108	14.7
78	15	20	633334	3500.01	DFT-s-OFDM PI/2 BPSK	100@0	17.84	18.75
78	15	20	633334	3500.01	DFT-s-OFDM QPSK	100@0	17.88	18.75
78	15	20	633334	3500.01	CP-OFDM QPSK	106@0	18.878	19.84
78	15	20	633334	3500.01	CP-OFDM 16 QAM	106@0	18.932	20.01
78	15	20	633334	3500.01	CP-OFDM 64 QAM	106@0	18.934	19.78
78	15	20	633334	3500.01	CP-OFDM 256 QAM	106@0	18.864	19.82
78	15	40	633334	3500.01	DFT-s-OFDM PI/2 BPSK	216@0	38.49	39.96
78	15	40	633334	3500.01	DFT-s-OFDM QPSK	216@0	38.627	40.02
78	15	40	633334	3500.01	CP-OFDM QPSK	216@0	38.622	40.07
78	15	40	633334	3500.01	CP-OFDM 16 QAM	216@0	38.545	40.01
78	15	40	633334	3500.01	CP-OFDM 64 QAM	216@0	38.569	39.87
78	15	40	633334	3500.01	CP-OFDM 256 QAM	216@0	38.604	39.91

78	15	50	633334	3500.01	DFT-s-OFDM PI/2 BPSK	270@0	48.246	49.84
78	15	50	633334	3500.01	DFT-s-OFDM QPSK	270@0	48.179	49.74
78	15	50	633334	3500.01	CP-OFDM QPSK	270@0	48.133	49.79
78	15	50	633334	3500.01	CP-OFDM 16 QAM	270@0	48.191	49.96
78	15	50	633334	3500.01	CP-OFDM 64 QAM	270@0	48.122	49.74
78	15	50	633334	3500.01	CP-OFDM 256 QAM	270@0	48.162	50.02

N78(10M)_DFT-s-OFDM_PI_2-BPSK_Outer_Full_Mid_CH

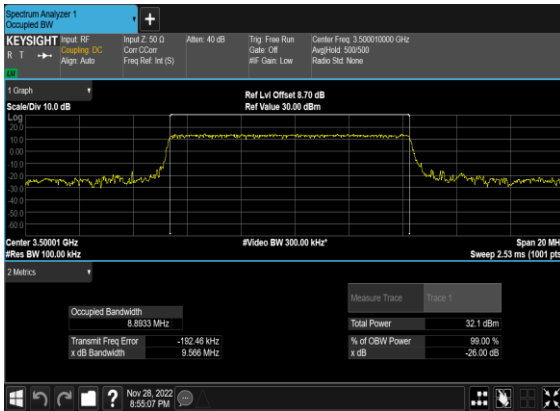

N78(10M)_DFT-s-OFDM_QPSK_Outer_Full_Mid_CH

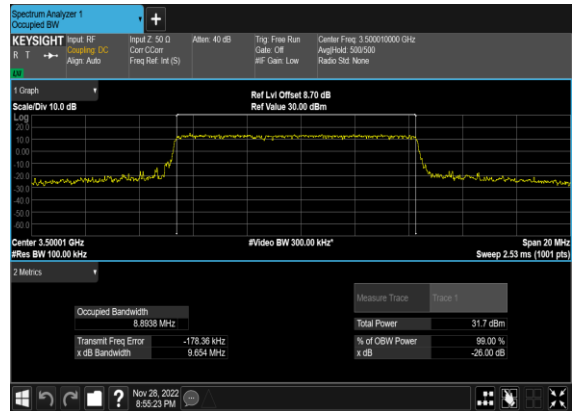

N78(10M)_CP-OFDM_QPSK_Outer_Full_Mid_CH



N78(10M)_CP-OFDM_16QAM_Outer_Full_Mid_CH

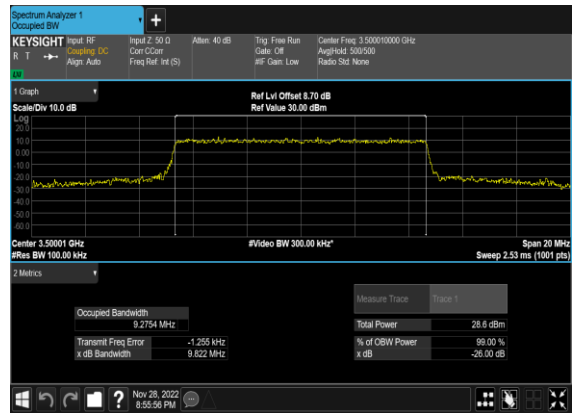

N78(10M)_CP-OFDM_64QAM_Outer_Full_Mid_CH

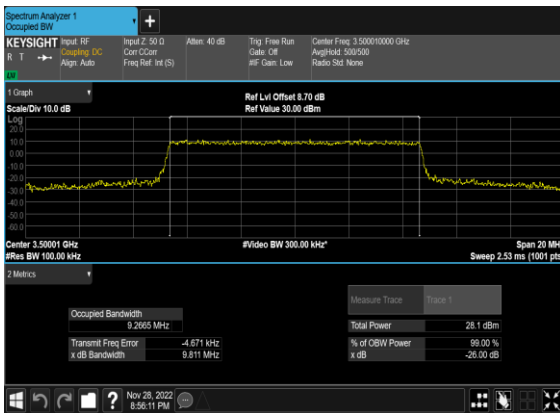

N78(10M)_CP-OFDM_256QAM_Outer_Full_Mid_CH

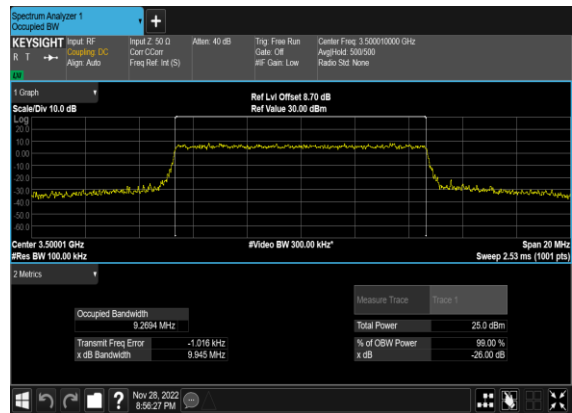

N78(15M)_DFT-s-OFDM_PI_2- BPSK_Outer_Full_Mid_CH

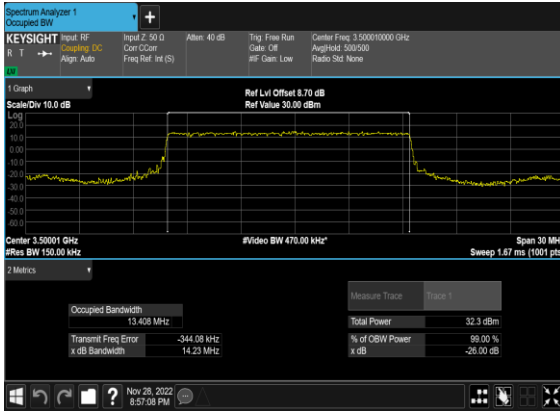

N78(15M)_DFT-s- OFDM_QPSK_Outer_Full_Mid_CH

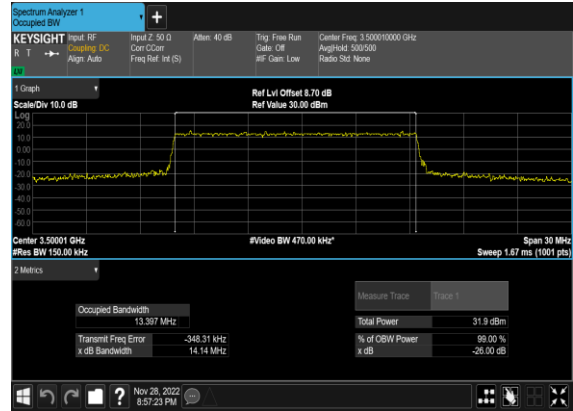

N78(15M)_CP- OFDM_QPSK_Outer_Full_Mid_CH

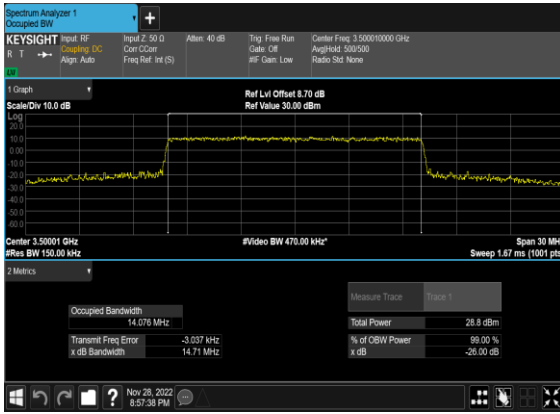

N78(15M)_CP-OFDM_16 QAM_Outer_Full_Mid_CH

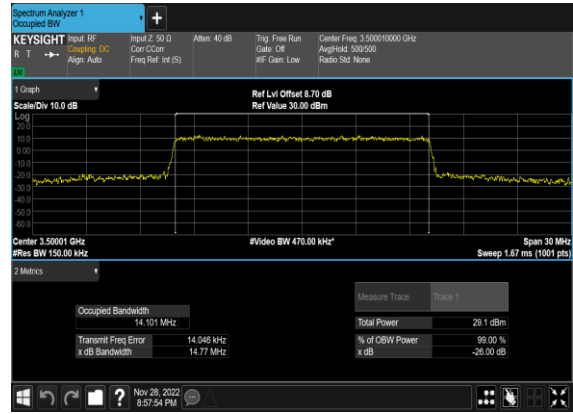

N78(15M)_CP-OFDM_64 QAM_Outer_Full_Mid_CH

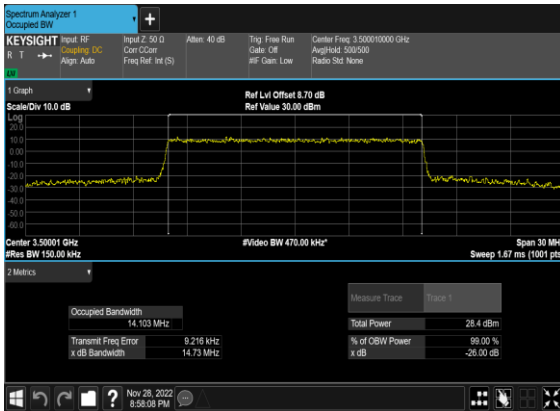

N78(15M)_CP-OFDM_256 QAM_Outer_Full_Mid_CH

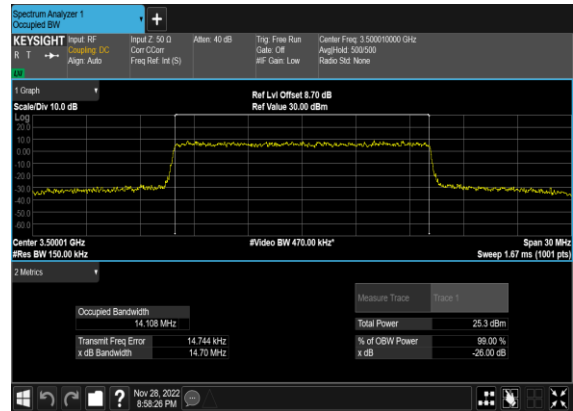

N78(20M)_DFT-s-OFDM_PI_2-BPSK_Outer_Full_Mid_CH



N78(20M)_DFT-s-OFDM_QPSK_Outer_Full_Mid_CH

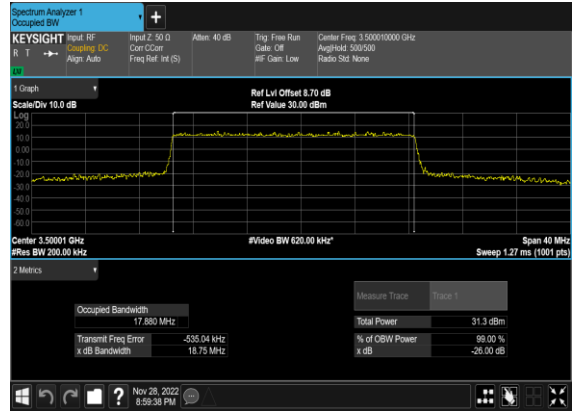

N78(20M)_CP-OFDM_QPSK_Outer_Full_Mid_CH

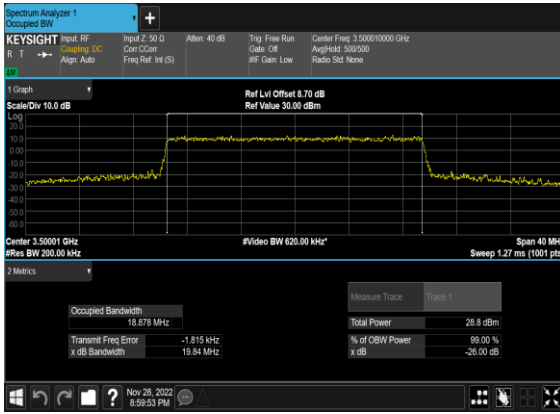

N78(20M)_CP-OFDM_16QAM_Outer_Full_Mid_CH



N78(20M)_CP-OFDM_64QAM_Outer_Full_Mid_CH

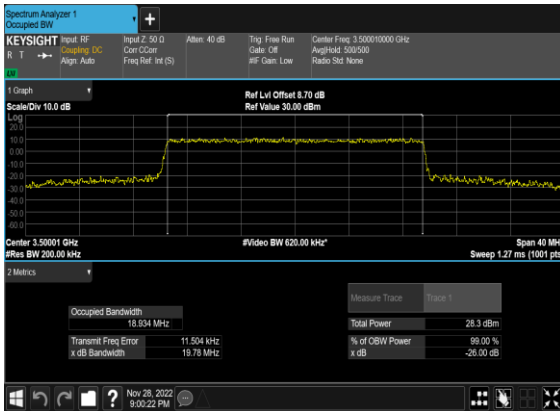

N78(20M)_CP-OFDM_256QAM_Outer_Full_Mid_CH

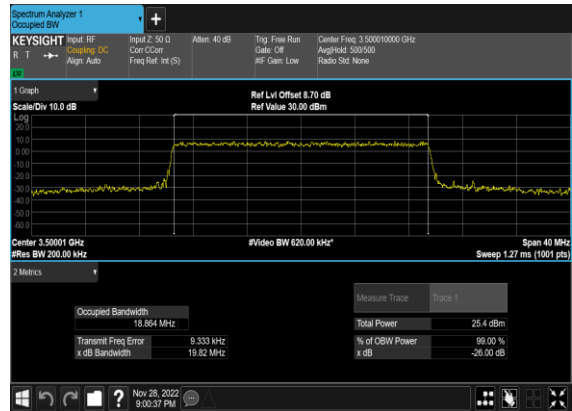

N78(40M)_DFT-s-OFDM_PI_2-BPSK_Outer_Full_Mid_CH

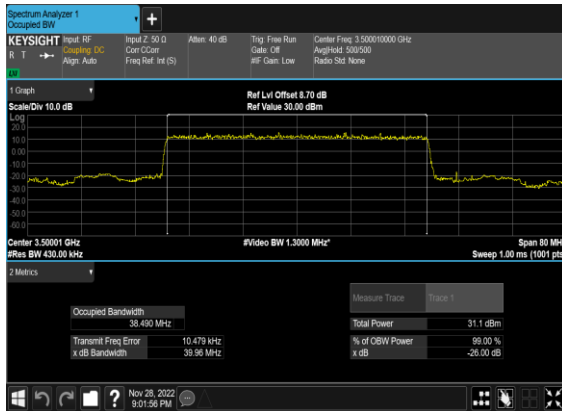

N78(40M)_DFT-s-OFDM_QPSK_Outer_Full_Mid_CH

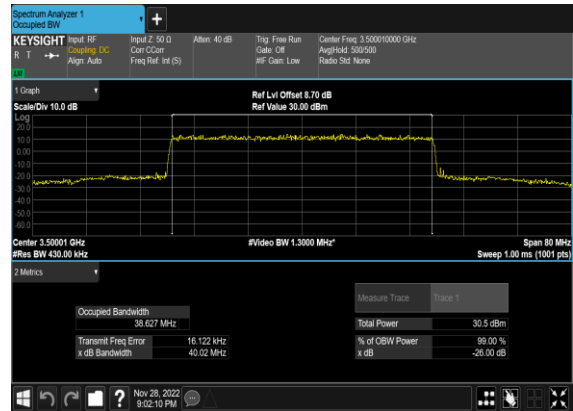

N78(40M)_CP-OFDM_QPSK_Outer_Full_Mid_CH

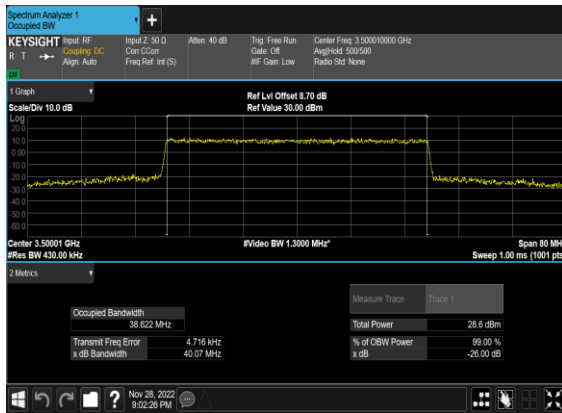

N78(40M)_CP-OFDM_16QAM_Outer_Full_Mid_CH



N78(40M)_CP-OFDM_64QAM_Outer_Full_Mid_CH

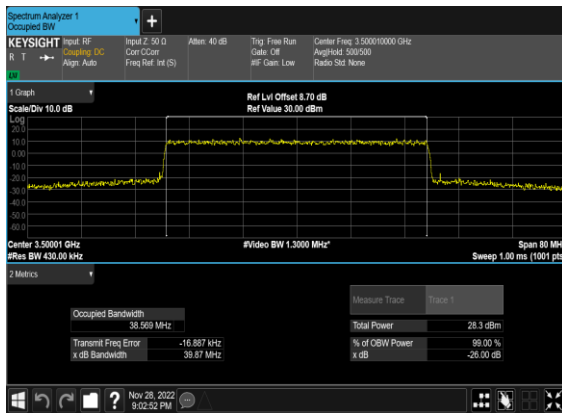

N78(40M)_CP-OFDM_256QAM_Outer_Full_Mid_CH

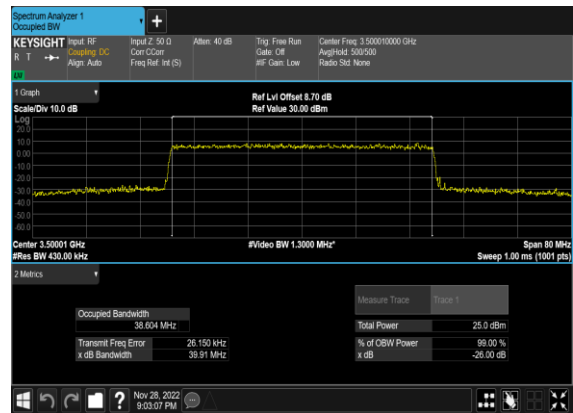

N78(50M)_DFT-s-OFDM_PI_2-BPSK_Outer_Full_Mid_CH

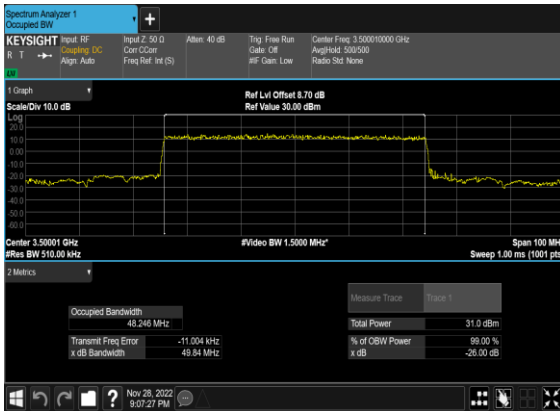

N78(50M)_DFT-s-OFDM_QPSK_Outer_Full_Mid_CH

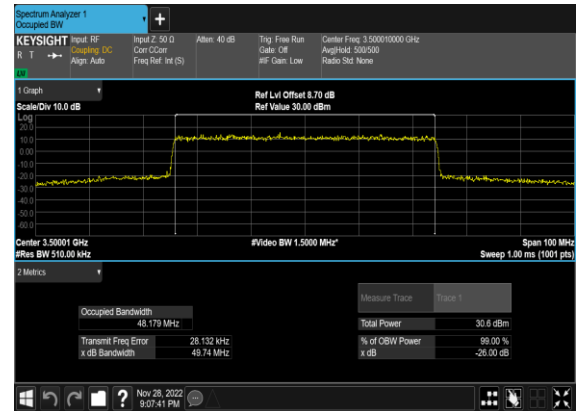

N78(50M)_CP-OFDM_QPSK_Outer_Full_Mid_CH

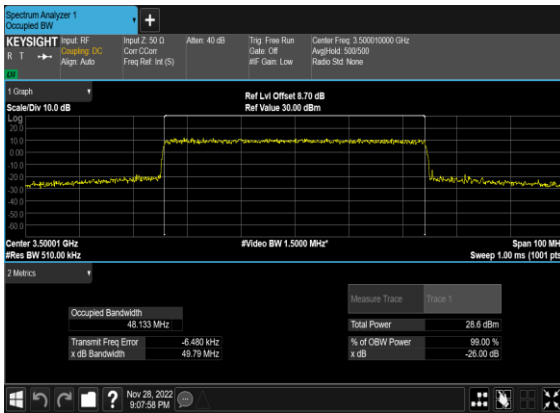

N78(50M)_CP-OFDM_16QAM_Outer_Full_Mid_CH

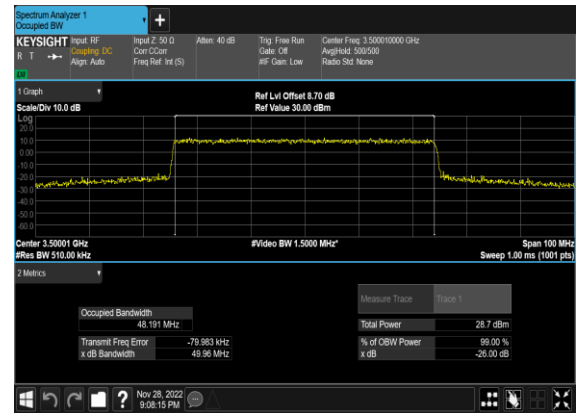

N78(50M)_CP-OFDM_64QAM_Outer_Full_Mid_CH

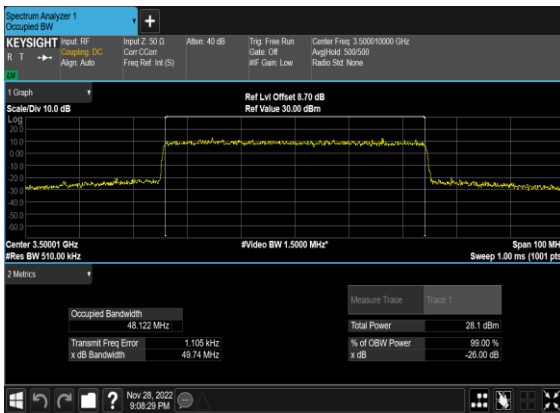

N78(50M)_CP-OFDM_256QAM_Outer_Full_Mid_CH

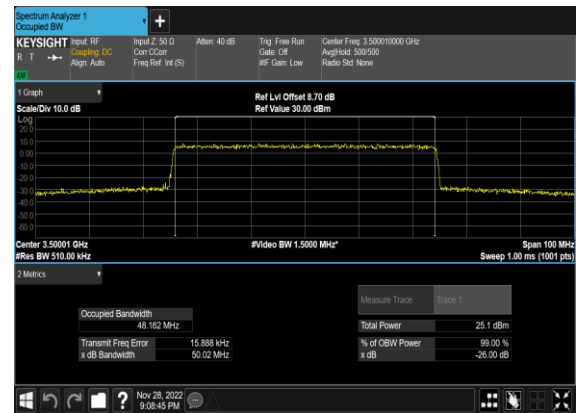

Conducted Spurious Emissions

NR Band	SCS (kHz)	Bandwidth (MHz)	Arfcn	Freq (MHz)	Modulation	RB	Result	Verdict
78	15	10	630334	3455.01	DFT-s-OFDM BPSK	1@0	see graph	---
78	15	10	630334	3455.01	DFT-s-OFDM BPSK	1@0	see graph	PASS
78	15	10	630334	3455.01	DFT-s-OFDM BPSK	1@0	see graph	PASS
78	15	10	630334	3455.01	DFT-s-OFDM QPSK	1@0	see graph	---
78	15	10	630334	3455.01	DFT-s-OFDM QPSK	1@0	see graph	PASS
78	15	10	630334	3455.01	DFT-s-OFDM QPSK	1@0	see graph	PASS
78	15	10	633334	3500.01	DFT-s-OFDM BPSK	1@0	see graph	---
78	15	10	633334	3500.01	DFT-s-OFDM BPSK	1@0	see graph	PASS
78	15	10	633334	3500.01	DFT-s-OFDM BPSK	1@0	see graph	PASS
78	15	10	633334	3500.01	DFT-s-OFDM QPSK	1@0	see graph	---
78	15	10	633334	3500.01	DFT-s-OFDM QPSK	1@0	see graph	PASS
78	15	10	633334	3500.01	DFT-s-OFDM QPSK	1@0	see graph	PASS
78	15	10	636333	3544.995	DFT-s-OFDM BPSK	1@0	see graph	---
78	15	10	636333	3544.995	DFT-s-OFDM BPSK	1@0	see graph	PASS
78	15	10	636333	3544.995	DFT-s-OFDM BPSK	1@0	see graph	PASS
78	15	10	636333	3544.995	DFT-s-OFDM QPSK	1@0	see graph	---
78	15	10	636333	3544.995	DFT-s-OFDM QPSK	1@0	see graph	PASS
78	15	10	636333	3544.995	DFT-s-OFDM QPSK	1@0	see graph	PASS
78	15	20	630667	3460.005	DFT-s-OFDM BPSK	1@0	see graph	---
78	15	20	630667	3460.005	DFT-s-OFDM BPSK	1@0	see graph	PASS
78	15	20	630667	3460.005	DFT-s-OFDM BPSK	1@0	see graph	PASS
78	15	20	630667	3460.005	DFT-s-OFDM QPSK	1@0	see graph	---

78	15	20	630667	3460.005	DFT-s-OFDM QPSK	1@0	see graph	PASS
78	15	20	630667	3460.005	DFT-s-OFDM QPSK	1@0	see graph	PASS
78	15	20	633334	3500.01	DFT-s-OFDM BPSK	1@0	see graph	---
78	15	20	633334	3500.01	DFT-s-OFDM BPSK	1@0	see graph	PASS
78	15	20	633334	3500.01	DFT-s-OFDM BPSK	1@0	see graph	PASS
78	15	20	633334	3500.01	DFT-s-OFDM QPSK	1@0	see graph	---
78	15	20	633334	3500.01	DFT-s-OFDM QPSK	1@0	see graph	PASS
78	15	20	633334	3500.01	DFT-s-OFDM QPSK	1@0	see graph	PASS
78	15	20	636000	3540.0	DFT-s-OFDM BPSK	1@0	see graph	---
78	15	20	636000	3540.0	DFT-s-OFDM BPSK	1@0	see graph	PASS
78	15	20	636000	3540.0	DFT-s-OFDM BPSK	1@0	see graph	PASS
78	15	20	636000	3540.0	DFT-s-OFDM QPSK	1@0	see graph	---
78	15	20	636000	3540.0	DFT-s-OFDM QPSK	1@0	see graph	PASS
78	15	20	636000	3540.0	DFT-s-OFDM QPSK	1@0	see graph	PASS
78	15	50	631667	3475.005	DFT-s-OFDM BPSK	1@0	see graph	---
78	15	50	631667	3475.005	DFT-s-OFDM BPSK	1@0	see graph	PASS
78	15	50	631667	3475.005	DFT-s-OFDM BPSK	1@0	see graph	PASS
78	15	50	631667	3475.005	DFT-s-OFDM QPSK	1@0	see graph	---
78	15	50	631667	3475.005	DFT-s-OFDM QPSK	1@0	see graph	PASS
78	15	50	631667	3475.005	DFT-s-OFDM QPSK	1@0	see graph	PASS
78	15	50	633334	3500.01	DFT-s-OFDM BPSK	1@0	see graph	---
78	15	50	633334	3500.01	DFT-s-OFDM BPSK	1@0	see graph	PASS
78	15	50	633334	3500.01	DFT-s-OFDM BPSK	1@0	see graph	PASS
78	15	50	633334	3500.01	DFT-s-OFDM QPSK	1@0	see graph	---

78	15	50	633334	3500.01	DFT-s-OFDM QPSK	1@0	see graph	PASS
78	15	50	633334	3500.01	DFT-s-OFDM QPSK	1@0	see graph	PASS
78	15	50	635000	3525.0	DFT-s-OFDM BPSK	1@0	see graph	---
78	15	50	635000	3525.0	DFT-s-OFDM BPSK	1@0	see graph	PASS
78	15	50	635000	3525.0	DFT-s-OFDM BPSK	1@0	see graph	PASS
78	15	50	635000	3525.0	DFT-s-OFDM QPSK	1@0	see graph	---
78	15	50	635000	3525.0	DFT-s-OFDM QPSK	1@0	see graph	PASS
78	15	50	635000	3525.0	DFT-s-OFDM QPSK	1@0	see graph	PASS

N78(10M)_DFT-s-OFDM_BPSK_Edge_1RB_Left_Low_CH

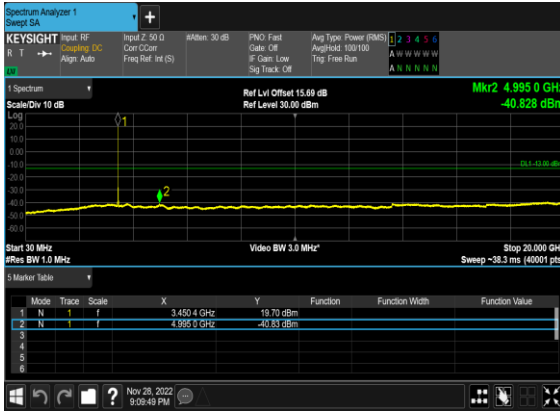

N78(10M)_DFT-s-OFDM_BPSK_Edge_1RB_Left_Low_CH

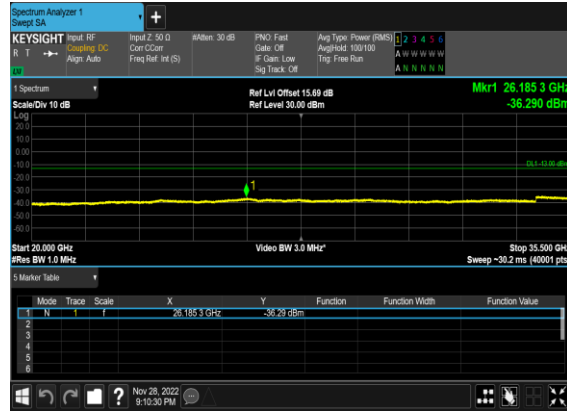

N78(10M)_DFT-s-OFDM_QPSK_Edge_1RB_Left_Low_CH



N78(10M)_DFT-s-OFDM_QPSK_Edge_1RB_Left_Low_CH



N78(10M)_DFT-s-OFDM_BPSK_Edge_1RB_Left_Mid_CH

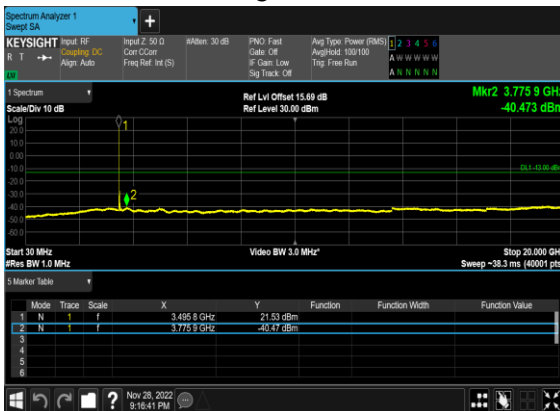

N78(10M)_DFT-s-OFDM_BPSK_Edge_1RB_Left_Mid_CH

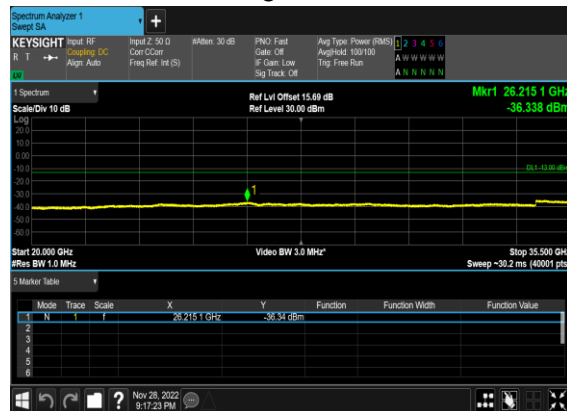

N78(10M)_DFT-s-OFDM_QPSK_Edge_1RB_Left_Mid_CH



N78(10M)_DFT-s-OFDM_QPSK_Edge_1RB_Left_Mid_CH

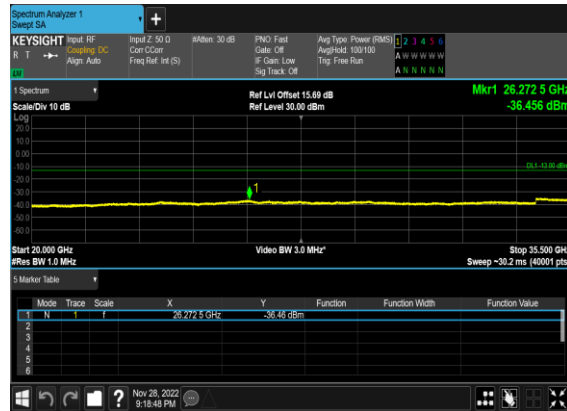

N78(10M)_DFT-s-OFDM_BPSK_Edge_1RB_Left_High_CH

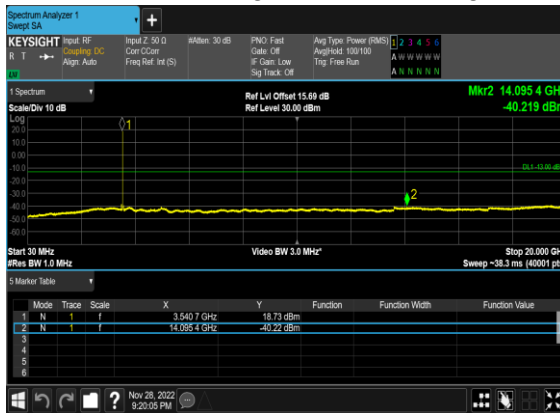

N78(10M)_DFT-s-OFDM_BPSK_Edge_1RB_Left_High_CH

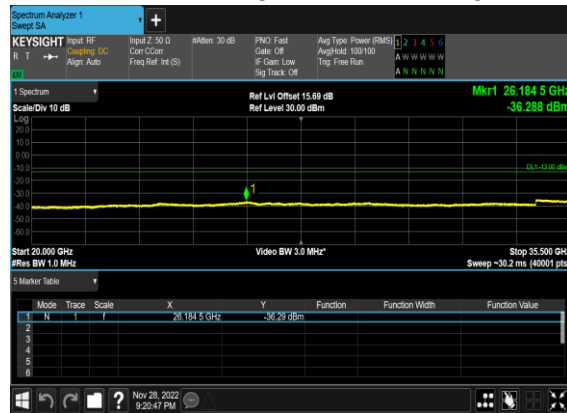

N78(10M)_DFT-s-OFDM_QPSK_Edge_1RB_Left_High_CH

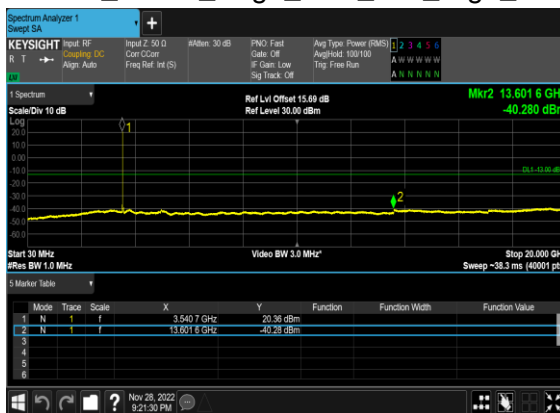

N78(10M)_DFT-s-OFDM_QPSK_Edge_1RB_Left_High_CH

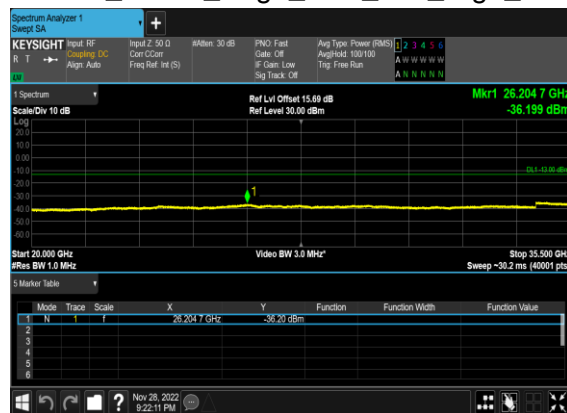

N78(20M)_DFT-s-OFDM_BPSK_Edge_1RB_Left_Low_CH

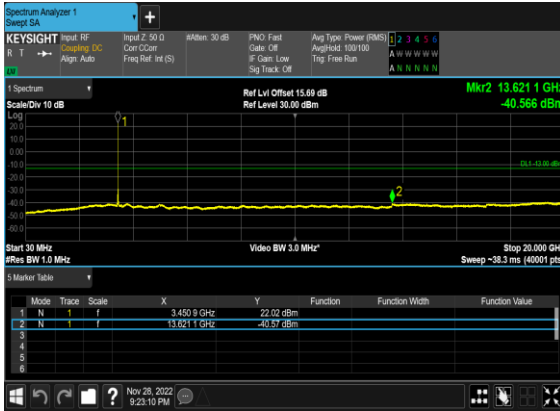

N78(20M)_DFT-s-OFDM_BPSK_Edge_1RB_Left_Low_CH

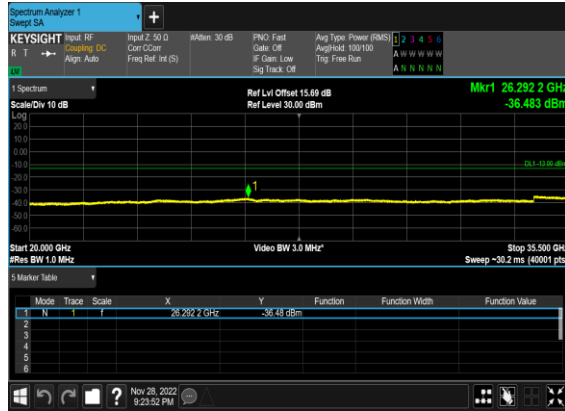

N78(20M)_DFT-s-OFDM_QPSK_Edge_1RB_Left_Low_CH

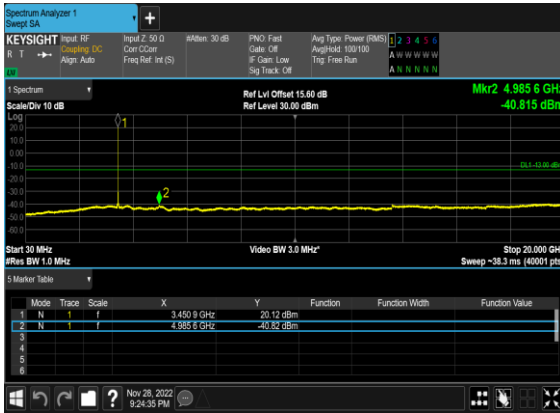

N78(20M)_DFT-s-OFDM_QPSK_Edge_1RB_Left_Low_CH

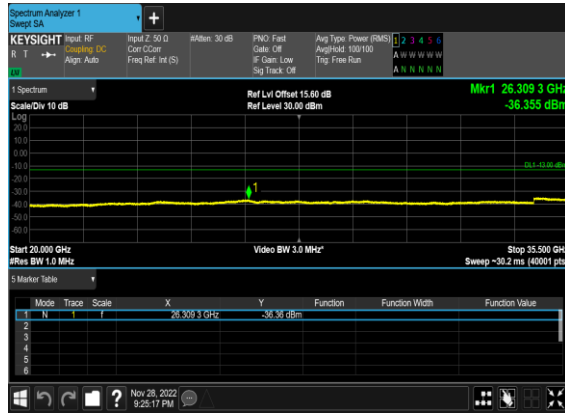

N78(20M)_DFT-s-OFDM_BPSK_Edge_1RB_Left_Mid_CH



N78(20M)_DFT-s-OFDM_BPSK_Edge_1RB_Left_Mid_CH

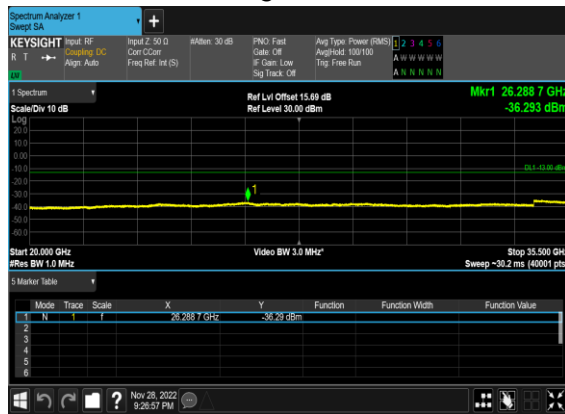

N78(20M)_DFT-s-OFDM_QPSK_Edge_1RB_Left_Mid_CH

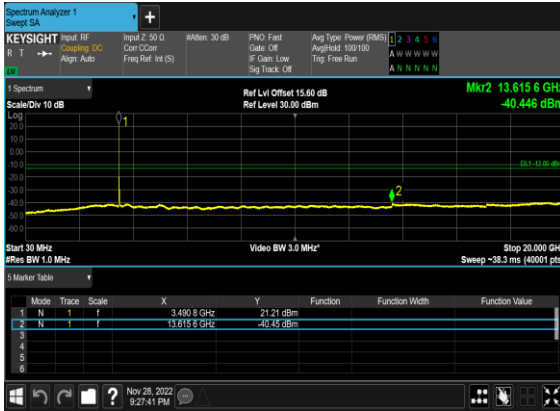

N78(20M)_DFT-s-OFDM_QPSK_Edge_1RB_Left_Mid_CH

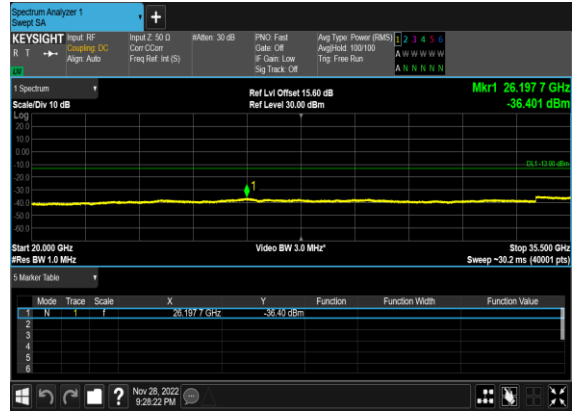

N78(20M)_DFT-s-OFDM_BPSK_Edge_1RB_Left_High_CH

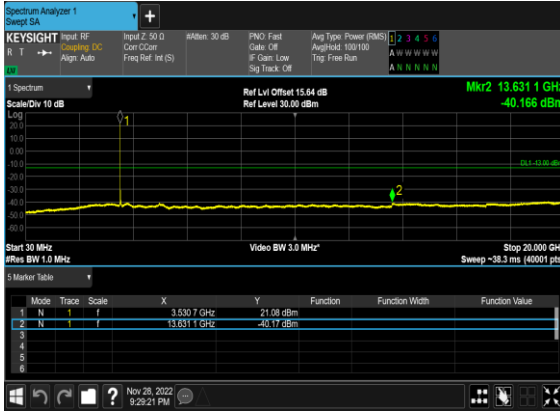

N78(20M)_DFT-s-OFDM_BPSK_Edge_1RB_Left_High_CH

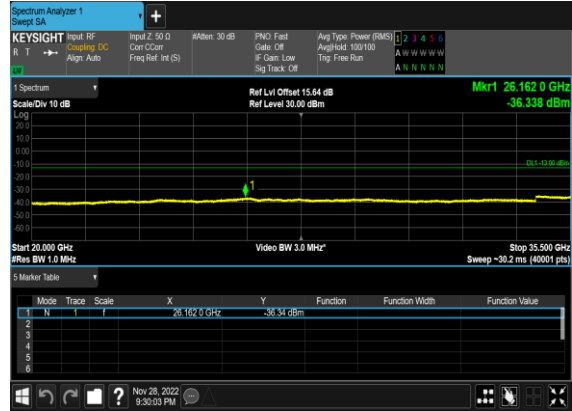

N78(20M)_DFT-s-OFDM_QPSK_Edge_1RB_Left_High_CH

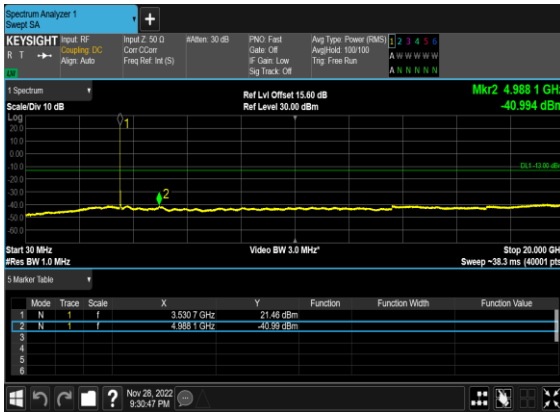

N78(20M)_DFT-s-OFDM_QPSK_Edge_1RB_Left_High_CH



N78(50M)_DFT-s-OFDM_BPSK_Edge_1RB_Left_Low_CH



N78(50M)_DFT-s-OFDM_BPSK_Edge_1RB_Left_Low_CH

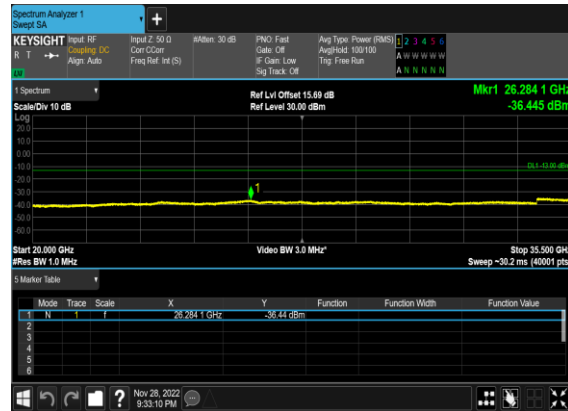

N78(50M)_DFT-s-OFDM_QPSK_Edge_1RB_Left_Low_CH

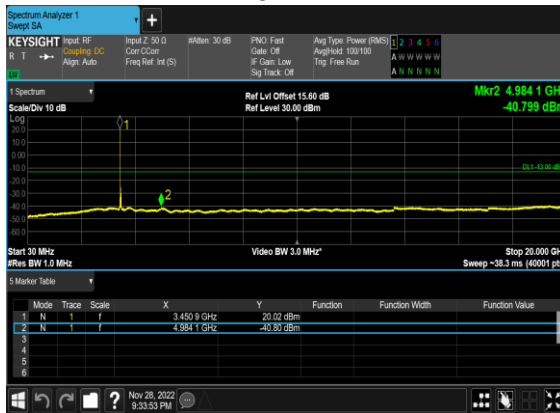

N78(50M)_DFT-s-OFDM_QPSK_Edge_1RB_Left_Low_CH

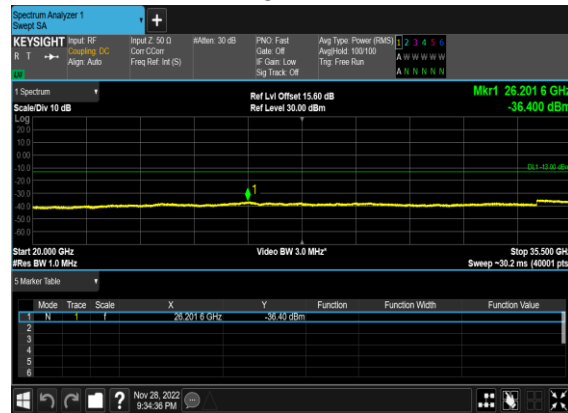

N78(50M)_DFT-s-OFDM_BPSK_Edge_1RB_Left_Mid_CH

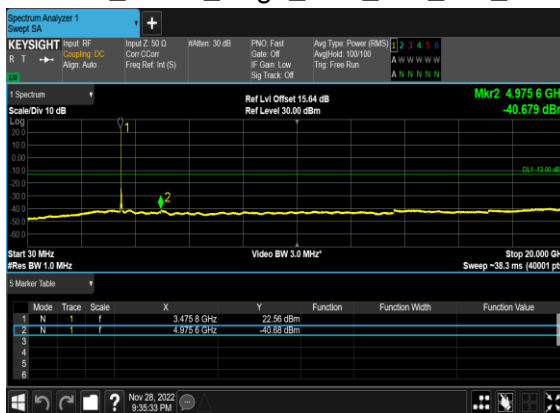

N78(50M)_DFT-s-OFDM_BPSK_Edge_1RB_Left_Mid_CH

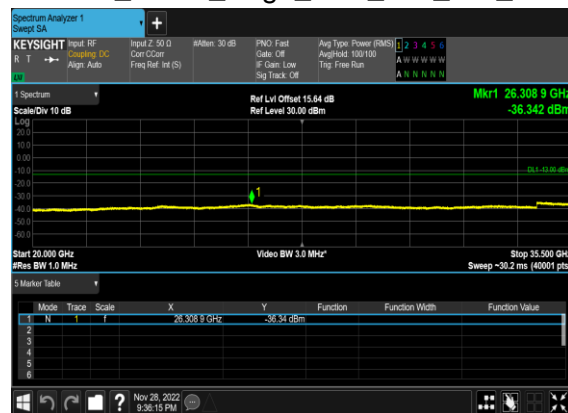

N78(50M)_DFT-s-OFDM_QPSK_Edge_1RB_Left_Mid_CH

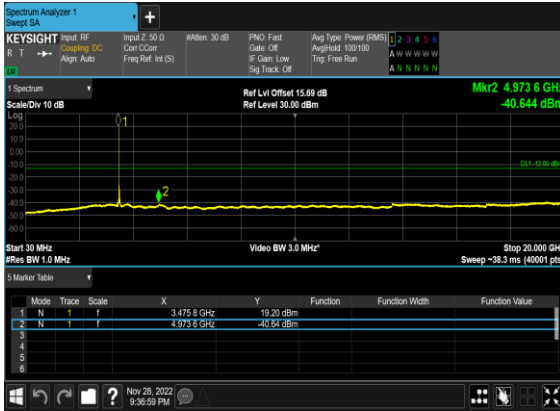

N78(50M)_DFT-s-OFDM_QPSK_Edge_1RB_Left_Mid_CH

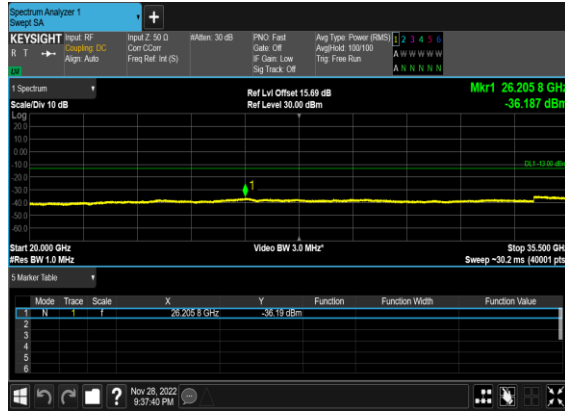

N78(50M)_DFT-s-OFDM_BPSK_Edge_1RB_Left_High_CH



N78(50M)_DFT-s-OFDM_BPSK_Edge_1RB_Left_High_CH

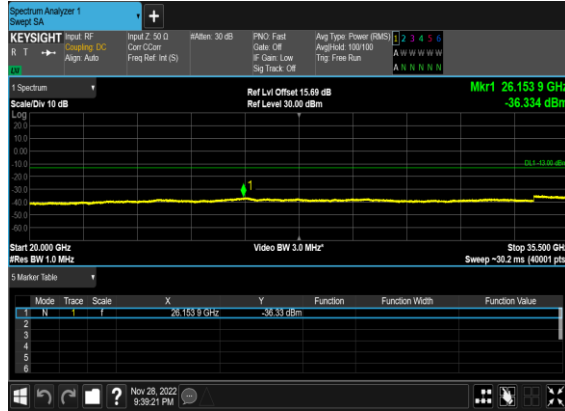

N78(50M)_DFT-s-OFDM_QPSK_Edge_1RB_Left_High_CH

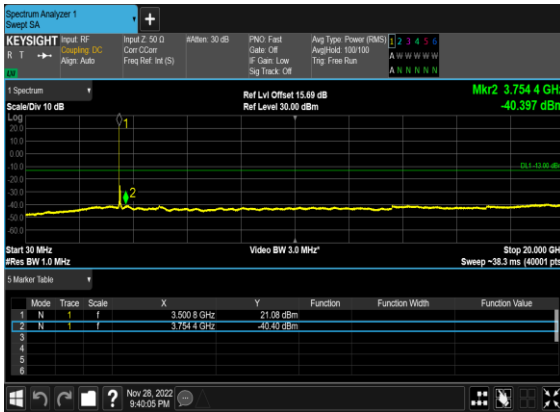

N78(50M)_DFT-s-OFDM_QPSK_Edge_1RB_Left_High_CH

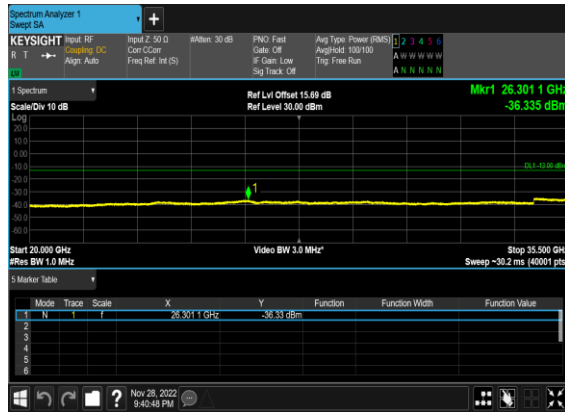

Conducted Band Edge

NR Band	SCS (kHz)	Bandwidth (MHz)	Arfcn	Freq (MHz)	Modulation	RB	Result	Verdict
78	15	10	630334	3455.01	DFT-s-OFDM BPSK	1@0	see graph	PASS
78	15	10	630334	3455.01	DFT-s-OFDM QPSK	1@0	see graph	PASS
78	15	10	630334	3455.01	DFT-s-OFDM BPSK	50@0	see graph	PASS
78	15	10	630334	3455.01	DFT-s-OFDM QPSK	50@0	see graph	PASS
78	15	10	636333	3544.995	DFT-s-OFDM BPSK	1@51	see graph	PASS
78	15	10	636333	3544.995	DFT-s-OFDM QPSK	1@51	see graph	PASS
78	15	10	636333	3544.995	DFT-s-OFDM BPSK	50@0	see graph	PASS
78	15	10	636333	3544.995	DFT-s-OFDM QPSK	50@0	see graph	PASS
78	15	20	630667	3460.005	DFT-s-OFDM BPSK	1@0	see graph	PASS
78	15	20	630667	3460.005	DFT-s-OFDM QPSK	1@0	see graph	PASS
78	15	20	630667	3460.005	DFT-s-OFDM BPSK	100@0	see graph	PASS
78	15	20	630667	3460.005	DFT-s-OFDM QPSK	100@0	see graph	PASS
78	15	20	636000	3540.0	DFT-s-OFDM BPSK	1@105	see graph	PASS
78	15	20	636000	3540.0	DFT-s-OFDM QPSK	1@105	see graph	PASS
78	15	20	636000	3540.0	DFT-s-OFDM BPSK	100@0	see graph	PASS
78	15	20	636000	3540.0	DFT-s-OFDM QPSK	100@0	see graph	PASS
78	15	50	631667	3475.005	DFT-s-OFDM BPSK	1@0	see graph	PASS
78	15	50	631667	3475.005	DFT-s-OFDM QPSK	1@0	see graph	PASS
78	15	50	631667	3475.005	DFT-s-OFDM BPSK	270@0	see graph	PASS
78	15	50	631667	3475.005	DFT-s-OFDM QPSK	270@0	see graph	PASS
78	15	50	635000	3525.0	DFT-s-OFDM BPSK	1@269	see graph	PASS
78	15	50	635000	3525.0	DFT-s-OFDM QPSK	1@269	see graph	PASS
78	15	50	635000	3525.0	DFT-s-OFDM BPSK	270@0	see graph	PASS
78	15	50	635000	3525.0	DFT-s-OFDM QPSK	270@0	see graph	PASS

N78(10M)_DFT-s-
OFDM_BPSK_Edge_1RB_Left_Low_CH

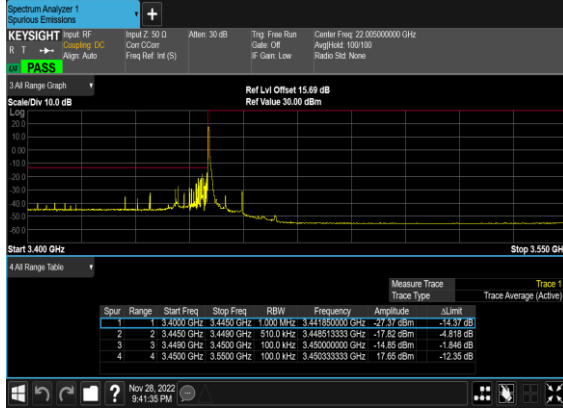

N78(10M)_DFT-s-
OFDM_QPSK_Edge_1RB_Left_Low_CH

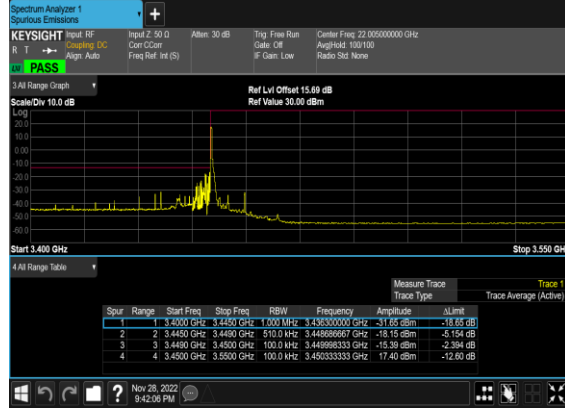

N78(10M)_DFT-s-
OFDM_BPSK_Outer_Full_Low_CH

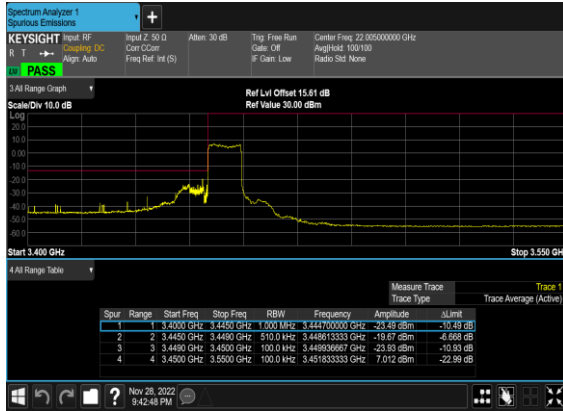

N78(10M)_DFT-s-
OFDM_QPSK_Outer_Full_Low_CH

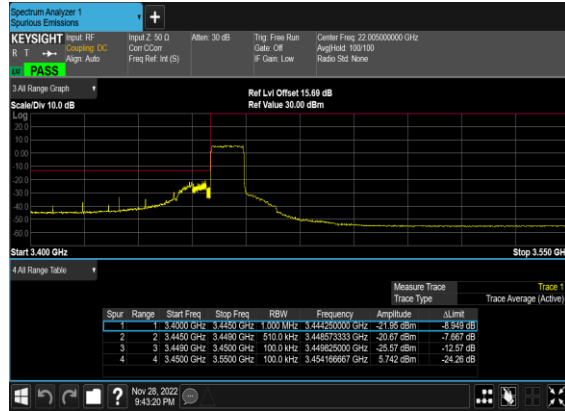

N78(10M)_DFT-s-
OFDM_BPSK_Edge_1RB_Right_High_CH

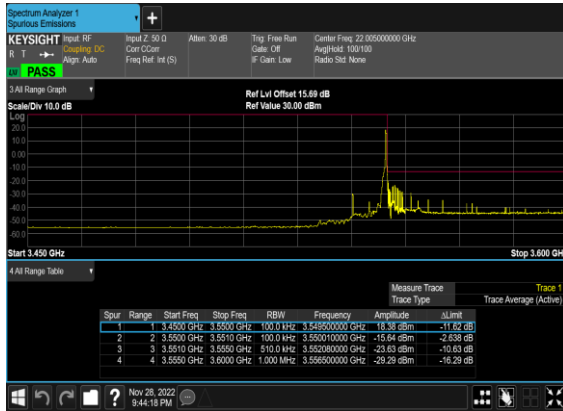

N78(10M)_DFT-s-
OFDM_QPSK_Edge_1RB_Right_High_CH

