



FCC RADIO TEST REPORT

FCC ID : ZL5B35EPA
Equipment : Mobile Phone
Brand Name : CAT
Model Name : B35
Standard : 47 CFR Part 2, 22(H), 24(E)

The product was received on Dec. 10, 2019 and testing was started from Dec. 24, 2019 and completed on Feb. 12, 2020. We, SPORTON INTERNATIONAL (Kunshan) INC. EMC & Wireless Communications Laboratory, would like to declare that the tested sample has been evaluated in accordance with the test procedures given in ANSI / TIA-603-E and has been in compliance with the applicable technical standards.

The report must not be used by the client to claim product certification, approval, or endorsement by A2LA or any agency of government.

The test results in this variant report apply exclusively to the tested model / sample. Without written approval of SPORTON INTERNATIONAL (Kunshan) INC. EMC & Wireless Communications Laboratory, the test report shall not be reproduced except in full.

Jason Jia

Reviewed by: Jason Jia / Supervisor

James Huang

Approved by: James Huang / Manager



Sporton International (Kunshan) Inc.

**No. 1098, Pengxi North Road, Kunshan Economic Development Zone Jiangsu Province 215300
People's Republic of China**



Table of Contents

History of this test report..... 3

Summary of Test Result..... 4

1.1 Applicant..... 5

1.2 Manufacturer 5

1.3 Product Feature of Equipment Under Test 5

1.4 Product Specification of Equipment Under Test 6

1.5 Modification of EUT 6

1.6 Maximum ERP/EIRP Power, Frequency Tolerance, and Emission Designator 6

1.7 Testing Location 7

1.8 Applicable Standards 7

2.1 Test Mode..... 8

2.2 Connection Diagram of Test System 9

2.3 Support Unit used in test configuration 9

2.4 Frequency List of Low/Middle/High Channels 10

3.1 Measuring Instruments..... 11

3.2 Conducted Output Power 12

3.3 Peak-to-Average Ratio 13

3.4 99% Occupied Bandwidth and 26dB Bandwidth Measurement..... 14

3.5 Conducted Band Edge 15

3.6 Conducted Spurious Emission 16

3.7 Frequency Stability..... 17

4.1 Measuring Instruments..... 18

4.2 Test Setup 18

4.3 Test Result of Radiated Test..... 18

4.4 Field Strength of Spurious Radiation Measurement 19

Appendix A. Test Results of Conducted Test

Appendix B. Test Results of Radiated Test

Appendix C. Test Setup Photographs



History of this test report

Report No.	Version	Description	Issued Date
FG9D1021-02A	01	Initial issue of report	Mar. 02, 2020



Summary of Test Result

Report Clause	Ref Std. Clause	Test Items	Result (PASS/FAIL)	Remark
3.2	§2.1046	Conducted Output Power	Pass	-
	§22.913 (a)(2)	Effective Radiated Power (GSM850) (WCDMA Band V)		
	§24.232 (c)	Equivalent Isotropic Radiated Power (GSM1900) (WCDMA Band II)		
3.3	§24.232 (d)	Peak-to-Average Ratio	Pass	
3.4	§2.1049	Occupied Bandwidth (GSM850) (WCDMA Band V) (GSM1900) (WCDMA Band II)	Pass	-
	§22.917 (b)			
	§24.238 (b)			
3.5	§2.1051	Band Edge Measurement (GSM850) (WCDMA Band V) (GSM1900) (WCDMA Band II)	Pass	-
	§22.917 (a)			
	§24.238 (a)			
3.6	§2.1051	Conducted Emission (GSM850) (WCDMA Band V) (GSM1900) (WCDMA Band II)	Pass	-
	§22.917 (a)			
	§24.238 (a)			
3.7	§2.1055	Frequency Stability Temperature & Voltage	Pass	-
	§22.355			
	§24.235			
4.4	§2.1053	Field Strength of Spurious Radiation (GSM850) (WCDMA Band V) (GSM1900) (WCDMA Band II)	Pass	Under limit 33.14 dB at 1672.000 MHz
	§22.917 (a)			
	§24.238 (a)			

Remark:

1. Not required means after assessing, test items are not necessary to carry out.
2. This is a variant report which can be referred Product Equality Declaration. All the test cases were performed on original report which can be referred to Sporton Report Number FG840307-04A. Based on the original report, the test cases were verified.

Declaration of Conformity:

The test results with all measurement uncertainty excluded are presented in accordance with the regulation limits or requirements declared by manufacturers.

Comments and Explanations:

The declared of product specification for EUT presented in the report are provided by the manufacturer, and the manufacturer takes all the responsibilities for the accuracy of product specification.



1 General Description

1.1 Applicant

Bullitt Group

One Valpy, Valpy Street, Reading, Berkshire, England RG1 1AR

1.2 Manufacturer

Bullitt Group

One Valpy, Valpy Street, Reading, Berkshire, England RG1 1AR

1.3 Product Feature of Equipment Under Test

Product Feature	
Equipment	Mobile Phone
Brand Name	CAT
Model Name	B35
FCC ID	ZL5B35EPA
EUT supports Radios application	GSM/EGPRS/WCDMA/HSPA/LTE WLAN 11a/b/g/n HT20/HT40 Bluetooth BR/EDR/LE
HW Version	MP_NZ
SW Version	LTE_0208120.0_B35_53
EUT Stage	Identical Prototype

Remark:

1. The above EUT's information was declared by manufacturer.
2. There are four types of EUT: Sample 1 is dual SIM with main source receiver, Sample 2 is dual SIM with second source receiver, Sample 3 is single SIM with main source receiver, Sample 4 is single SIM with second source receiver, just different suppliers. According to the difference, we choose sample 1 to full test.



1.4 Product Specification of Equipment Under Test

Standards-related Product Specification	
Tx Frequency	GSM/GPRS/EDGE: 850: 824.2 MHz ~ 848.8 MHz 1900: 1850.2 MHz ~ 1909.8MHz WCDMA: Band II: 1852.4 MHz ~ 1907.6 MHz
Rx Frequency	GSM/GPRS/EDGE: 850: 869.2 MHz ~ 893.8 MHz 1900: 1930.2 MHz ~ 1989.8 MHz WCDMA: Band II: 1932.4 MHz ~ 1987.6 MHz
Maximum Output Power to Antenna	GSM/GPRS/EDGE: 850: 32.88 dBm 1900: 30.89 dBm WCDMA: Band II: 23.11 dBm
Antenna Type	Identical Prototype
Antenna Gain	Cellular Band: -0.50 dBi PCS Band: -0.50 dBi
Type of Modulation	GSM: GMSK GPRS: GMSK EDGE: GMSK / 8PSK WCDMA: BPSK (Uplink) HSDPA: QPSK (Uplink) HSUPA: QPSK (Uplink)

1.5 Modification of EUT

No modifications are made to the EUT during all test items.

1.6 Maximum ERP/EIRP Power, Frequency Tolerance, and Emission Designator

FCC Rule	System	Type of Modulation	Maximum ERP/EIRP (W)	Frequency Tolerance (ppm)	Emission Designator
Part 22H	GSM850 GSM	GMSK	-	0.0191 ppm	242KGXW



1.7 Testing Location

Test Site	Sporton International (Kunshan) Inc.	
Test Site Location	No. 1098, Pengxi North Road, Kunshan Economic Development Zone Jiangsu Province 215300 People's Republic of China TEL: +86-0512-5790-0158 FAX: +86-0512-5790-0958	
Test Site No.	Sporton Site No.	
	TH01-KS	03CH04--KS
Test Engineer	Levi zhao	Bonner Qian
Temperature	21~25°C	22~23°C
Relative Humidity	41~45%	41~42%

FCC designation No.: CN1257

FCC Test Site Registration No.: 314309

1.8 Applicable Standards

According to the specifications of the manufacturer, the EUT must comply with the requirements of the following standards:

- ♦ ANSI C63.26-2015
- ♦ ANSI / TIA-603-E
- ♦ 47 CFR Part 2, 22(H), 24(E)
- ♦ FCC KDB 971168 D01 Power Meas. License Digital Systems v03r01
- ♦ FCC KDB 412172 D01 Determining ERP and EIRP v01r01

Remark:

1. All test items were verified and recorded according to the standards and without any deviation during the test.
2. This EUT has also been tested and complied with the requirements of FCC Part 15, Subpart B, recorded in a separate test report.



2 Test Configuration of Equipment Under Test

2.1 Test Mode

Antenna port conducted and radiated test items were performed according to KDB 971168 D01 Power Meas. License Digital Systems v03r01 with maximum output power.

For radiated measurement, pre-scanned in three orthogonal panels, X, Y, Z. The worst cases (Y plane) were recorded in this report.

Radiated emissions were investigated as following frequency range:

1. 30 MHz to 9000 MHz for GSM850 and WCDMA Band V1. 30 MHz to 19100 MHz for GSM1900 and WCDMA Band II

All modes and data rates and positions were investigated.

Test modes are chosen to be reported as the worst case configuration below:

Test Modes		
Band	Radiated TCs	Conducted TCs
GSM850	<ul style="list-style-type: none"> ■ GSM Link ■ EDGE Class 8 Link 	<ul style="list-style-type: none"> ■ GSM Link ■ EDGE Class 8 Link
GSM1900	<ul style="list-style-type: none"> ■ GPRS Class 8 Link 	<ul style="list-style-type: none"> ■ GPRS Class 8 Link
WCDMA Band II	<ul style="list-style-type: none"> ■ RMC 12.2Kbps Link 	<ul style="list-style-type: none"> ■ RMC 12.2Kbps Link

2.2 Connection Diagram of Test System

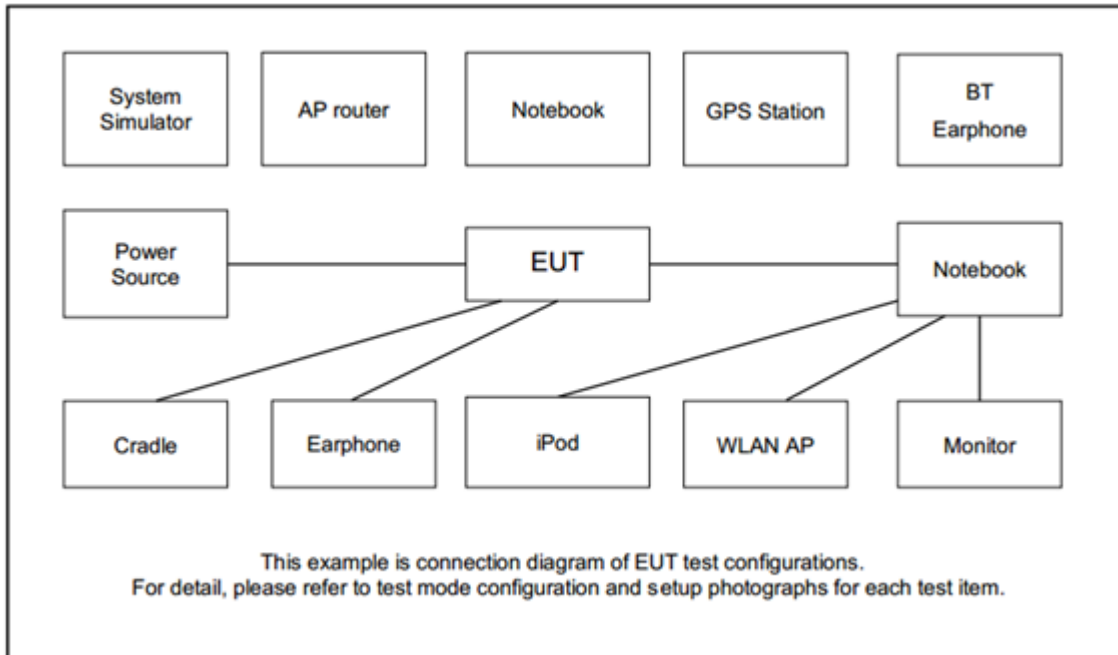

2.3 Support Unit used in test configuration

Item	Equipment	Trade Name	Model No.	FCC ID	Data Cable	Power Cord
1.	System Simulator	R&S	CMU 200	N/A	N/A	Unshielded, 1.8 m



2.4 Frequency List of Low/Middle/High Channels

Frequency List				
Band	Channel/Frequency(MHz)	Lowest	Middle	Highest
GSM850	Channel	128	189	251
	Frequency	824.2	836.4	848.8
WCDMA Band V	Channel	4132	4182	4233
	Frequency	826.4	836.4	846.6
GSM1900	Channel	512	661	810
	Frequency	1850.2	1880.0	1909.8
WCDMA Band II	Channel	9262	9400	9538
	Frequency	1852.4	1880.0	1907.6

3 Conducted Test Result

3.1 Measuring Instruments

See list of measuring instruments of this test report.

3.1.1 Test Setup

3.1.2 Conducted Output Power

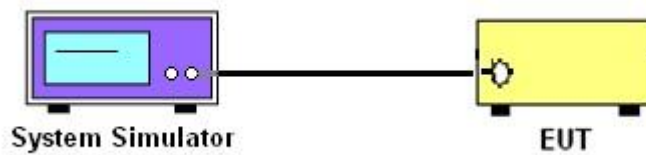

3.1.3 Peak-to-Average Ratio, Occupied Bandwidth, Conducted Band-Edge and Conducted Spurious Emission

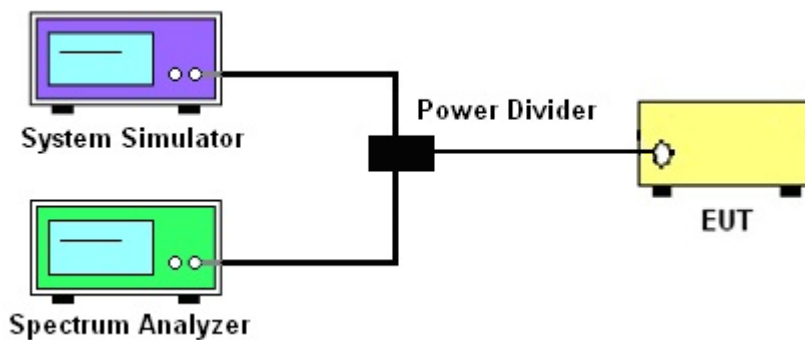

3.1.4 Frequency Stability

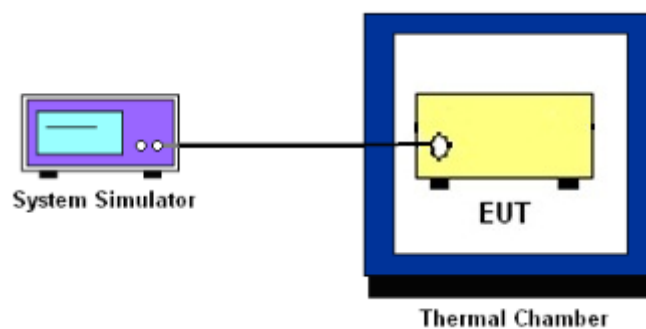

3.1.5 Test Result of Conducted Test

Please refer to Appendix A.



3.2 Conducted Output Power

3.2.1 Description of the Conducted Output Power

A system simulator was used to establish communication with the EUT. Its parameters were set to enforce EUT transmitting at the maximum power. The measured power in the radio frequency on the transmitter output terminals shall be reported.

The ERP of mobile transmitters must not exceed 7 Watts for GSM850 and WCDMA Band V

The EIRP of mobile transmitters must not exceed 2 Watts for GSM1900 and WCDMA Band II

According to KDB 412172 D01 Power Approach,

$EIRP = P_T + G_T - L_C$, $ERP = EIRP - 2.15$, where

P_T = transmitter output power in dBm

G_T = gain of the transmitting antenna in dBi

L_C = signal attenuation in the connecting cable between the transmitter and antenna in dB

3.2.2 Test Procedures

1. The transmitter output port was connected to the system simulator.
2. Set EUT at maximum power through system simulator.
3. Select lowest, middle, and highest channels for each band and different modulation.
4. Measure the maximum burst average power for GSM and maximum average power for other modulation signal.



3.3 Peak-to-Average Ratio

3.3.1 Description of the PAR Measurement

The peak-to-average ratio (PAR) of the transmission may not exceed 13 dB.

3.3.2 Test Procedures

The testing follows ANSI C63.26-2015 Section 5.2.6

1. The EUT was connected to spectrum analyzer and system simulator via a power divider.
2. Set EUT to transmit at maximum output power.
3. When the duty cycle is less than 98%, then signal gating will be implemented on the spectrum analyzer by triggering from the system simulator.
4. Set the CCDF (Complementary Cumulative Distribution Function) option of the spectrum analyzer.
5. Record the maximum PAPR level associated with a probability of 0.1%.



3.4 99% Occupied Bandwidth and 26dB Bandwidth Measurement

3.4.1 Description of 99% Occupied Bandwidth and 26dB Bandwidth Measurement

The occupied bandwidth is the width of a frequency band such that, below the lower and above the upper frequency limits, the mean powers emitted are each equal to a specified percentage 0.5% of the total mean transmitted power.

The 26 dB emission bandwidth is defined as the frequency range between two points, one above and one below the carrier frequency, at which the spectral density of the emission is attenuated 26 dB below the maximum in-band spectral density of the modulated signal. Spectral density (power per unit bandwidth) is to be measured with a detector of resolution bandwidth equal to approximately 1.0% of the emission bandwidth.

3.4.2 Test Procedures

The testing follows ANSI C63.26-2015 Section 5.4.3 (26dB) and Section 5.4.4 (99OB)

1. The EUT was connected to spectrum analyzer and system simulator via a power divider.
2. The spectrum analyzer center frequency is set to the nominal EUT channel center frequency. The span range for the spectrum analyzer shall be between two and five times the anticipated OBW.
3. The nominal resolution bandwidth (RBW) shall be in the range of 1 to 5 % of the anticipated OBW, and the VBW shall be at least 3 times the RBW.
4. Set the detection mode to peak, and the trace mode to max hold.
5. Determine the reference value: Set the EUT to transmit a modulated signal. Allow the trace to stabilize. Set the spectrum analyzer marker to the highest level of the displayed trace. (this is the reference value)
6. Determine the “-26 dB down amplitude” as equal to (Reference Value – X).
7. Place two markers, one at the lowest and the other at the highest frequency of the envelope of the spectral display such that each marker is at or slightly below the “-X dB down amplitude” determined in step 6. If a marker is below this “-X dB down amplitude” value it shall be placed as close as possible to this value. The OBW is the positive frequency difference between the two markers.
8. Use the 99 % power bandwidth function of the spectrum analyzer and report the measured bandwidth.



3.5 Conducted Band Edge

3.5.1 Description of Conducted Band Edge Measurement

The power of any emission outside of the authorized operating frequency ranges must be lower than the transmitter power (P) by a factor of at least $43 + 10 \log (P)$ dB.

3.5.2 Test Procedures

The testing follows FCC KDB 971168 D01 v03r01 Section 6.1.

1. The EUT was connected to the spectrum analyzer and system simulator via a power divider.
2. The RF output of EUT was connected to the spectrum analyzer by an RF cable and attenuator. The path loss was compensated to the results for each measurement.
3. The band edges of low and high channels for the highest RF powers were measured.
4. The RF fundamental frequency should be excluded against the limit line in the operating frequency band.
5. The limit line is derived from $43 + 10\log(P)$ dB below the transmitter power P(Watts)



3.6 Conducted Spurious Emission

3.6.1 Description of Conducted Spurious Emission Measurement

The power of any emission outside of the authorized operating frequency ranges must be lower than the transmitter power (P) by a factor of at least $43 + 10 \log (P)$ dB.

It is measured by means of a calibrated spectrum analyzer and scanned from 30 MHz up to a frequency including its 10th harmonic.

3.6.2 Test Procedures

The testing follows FCC KDB 971168 D01 v03r01 Section 6.1.

1. The EUT was connected to the spectrum analyzer and system simulator via a power divider.
2. The RF output of EUT was connected to the spectrum analyzer by an RF cable and attenuator. The path loss was compensated to the results for each measurement.
3. The middle channel for the highest RF power within the transmitting frequency was measured.
4. The conducted spurious emission for the whole frequency range was taken.
5. The RF fundamental frequency should be excluded against the limit line in the operating frequency band.
6. The limit line is derived from $43 + 10\log(P)$ dB below the transmitter power P(Watts)



3.7 Frequency Stability

3.7.1 Description of Frequency Stability Measurement

22.355

The frequency stability shall be measured by variation of ambient temperature and variation of primary supply voltage to ensure that the fundamental emission stays within the authorized frequency block. The frequency stability of the transmitter shall be maintained within $\pm 0.00025\%$ ($\pm 2.5\text{ppm}$) of the center frequency.

24.235

The frequency stability shall be sufficient to ensure that the fundamental emission stays within the authorized frequency block.

3.7.2 Test Procedures for Temperature Variation

The testing follows FCC KDB 971168 D01 v03r01 Section 9.0.

1. The EUT was set up in the thermal chamber and connected with the system simulator.
2. With power OFF, the temperature was decreased to -30°C and the EUT was stabilized before testing. Power was applied and the maximum change in frequency was recorded within one minute.
3. With power OFF, the temperature was raised in 10°C steps up to 50°C . The EUT was stabilized at each step for at least half an hour. Power was applied and the maximum frequency change was recorded within one minute.

3.7.3 Test Procedures for Voltage Variation

The testing follows FCC KDB 971168 D01 v03r01 Section 9.0.

1. The EUT was placed in a temperature chamber at $20\pm 5^{\circ}\text{C}$ and connected with the system simulator.
2. The power supply voltage to the EUT was varied from 85% to 115% of the nominal value measured at the input to the EUT.
3. The variation in frequency was measured for the worst case.

4 Radiated Test Items

4.1 Measuring Instruments

See list of measuring instruments of this test report.

4.2 Test Setup

For radiated test from 30MHz to 1GHz

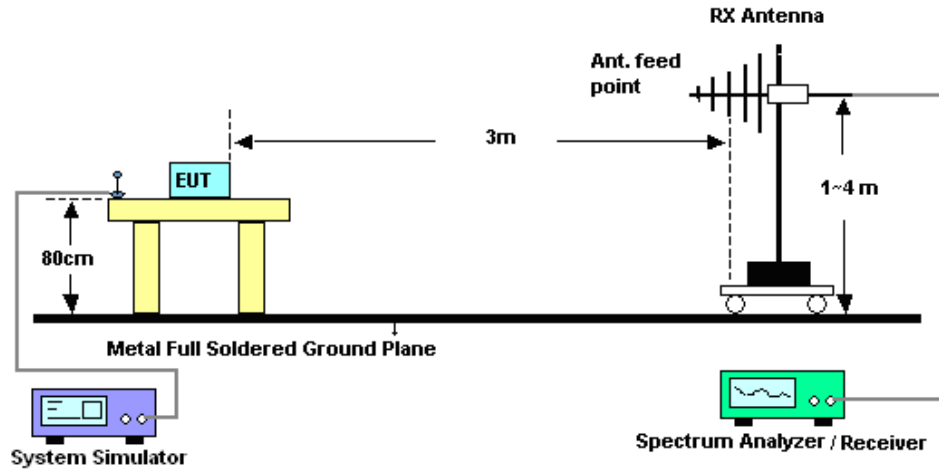

For radiated test above 1GHz

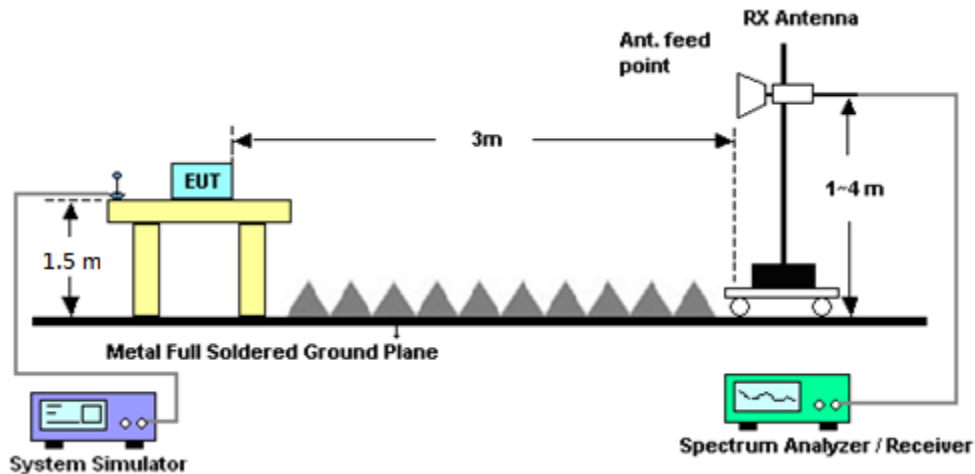

4.3 Test Result of Radiated Test

Please refer to Appendix B.



4.4 Field Strength of Spurious Radiation Measurement

4.4.1 Description of Field Strength of Spurious Radiated Measurement

The power of any emission outside of the authorized operating frequency ranges must be attenuated below the transmitter power (P) by a factor of at least $43 + 10 \log (P)$ dB. The spectrum is scanned from 30 MHz up to a frequency including its 10th harmonic.

4.4.2 Test Procedures

The testing follows FCC KDB 971168 D01 v03r01 Section 7 and ANSI / TIA-603-E Section 2.2.12.

1. The EUT was placed on a rotatable wooden table 0.8 meters for frequency below 1GHz and 1.5 meter for frequency above 1GHz above the ground.
2. The EUT was set 3 meters from the receiving antenna, which was mounted on the antenna tower.
3. The table was rotated 360 degrees to determine the position of the highest spurious emission.
4. The height of the receiving antenna is varied between one meter and four meters to search for the maximum spurious emission for both horizontal and vertical polarizations.
5. Make the measurement with the spectrum analyzer's RBW = 1MHz, VBW = 3MHz, taking record of maximum spurious emission.
6. A horn antenna was substituted in place of the EUT and was driven by a signal generator.
7. Tune the output power of signal generator to the same emission level with EUT maximum spurious emission.
8. Taking the record of output power at antenna port.
9. Repeat step 7 to step 8 for another polarization.
10. $EIRP (dBm) = S.G. Power - Tx Cable Loss + Tx Antenna Gain$
11. $ERP (dBm) = EIRP - 2.15$
12. The RF fundamental frequency should be excluded against the limit line in the operating frequency band.
13. The limit line is derived from $43 + 10\log(P)$ dB below the transmitter power P(Watts)



5 List of Measuring Equipment

Instrument	Manufacturer	Model No.	Serial No.	Characteristics	Calibration Date	Test Date	Due Date	Remark
EXA Spectrum Analyzer	Keysight	N9010A	MY55370528	10Hz-44GHz	Apr. 16, 2019	Dec. 24, 2019	Apr. 15, 2020	Radiation (03CH04-KS)
Bilog Antenna	TeseQ	CBL 6112D	44483	30MHz-1GHz	Apr. 19, 2019	Dec. 24, 2019	Apr. 18, 2020	Radiation (03CH04-KS)
Broad-Band Horn Antenna	Schwarzbeck MESS-ELEKT RONIK	BBHA9120D	01648	1GHz~18GHz	Jan. 27, 2019	Dec. 24, 2019	Jan. 26, 2020	Radiation (03CH04-KS)
Amplifier	SONOMA	310N	380827	9KHz-1GHz Gain 32dB	Aug. 06, 2019	Dec. 24, 2019	Aug. 05, 2020	Radiation (03CH04-KS)
EMI Test Receiver	Keysight	N9038A	MY56400004	3Hz~8.5GHz;M ax 30dBm	Jul. 18, 2019	Dec. 24, 2019	Jul. 17, 2020	Radiation (03CH04-KS)
SHF-EHF Horn	Com-power	AH-840	101093	18GHz~40GHz	Feb. 23, 2019	Dec. 24, 2019	Feb. 22, 2020	Radiation (03CH04-KS)
Amplifier	Agilent	8449B	MV53270316	1GHz~26.5GHz >23dB	Dec. 22, 2018	Dec. 24, 2019	Oct. 17, 2020	Radiation (03CH04-KS)
Spectrum Analyzer	R&S	FSV40	KS150209JCGS01	101040	Nov. 02, 2019	Feb. 12, 2020	Nov. 01, 2020	Conducted (TH01-KS)
Radio communication analyzer	Anritsu	MT8820C	KS141204JCGS05	6201432830	Jan. 14, 2019	Jan. 08, 2020	Jan. 13, 2020	Conducted (TH01-KS)
DC Power Supply	GW INSTRUK	GPS-3030D	KS071211JCGS01	E1884515	Aug. 02, 2019	Feb. 12, 2020	Aug. 01, 2020	Conducted (TH01-KS)
Radio communication analyzer	Anritsu	MT8821C	K180502JGE01	6261806798	Apr. 16, 2019	Feb. 12, 2020	Apr. 15, 2020	Conducted (TH01-KS)
Temperature & humidity chamber	Hongzhan	LP-150U	KS140413JCGS01	H2014011440	Jul. 04, 2019	Feb. 12, 2020	Jul. 03, 2020	Conducted (TH01-KS)



6 Uncertainty of Evaluation

Uncertainty of Radiated Emission Measurement (30 MHz ~ 1000 MHz)

Measuring Uncertainty for a Level of Confidence of 95% ($U = 2Uc(y)$)	3.3
---	-----

Uncertainty of Radiated Emission Measurement (1 GHz ~ 18 GHz)

Measuring Uncertainty for a Level of Confidence of 95% ($U = 2Uc(y)$)	2.8
---	-----

Uncertainty of Radiated Emission Measurement (18 GHz ~ 40 GHz)

Measuring Uncertainty for a Level of Confidence of 95% ($U = 2Uc(y)$)	2.8
---	-----



Appendix A. Test Results of Conducted Test

Conducted Output Power(Average power)

Conducted Power (*Unit: dBm)						
Band	GSM850			GSM1900		
Channel	128	189	251	512	661	810
Frequency	824.2	836.4	848.8	1850.2	1880.0	1909.8
GSM	32.55	32.75	32.88	30.89	30.56	30.51
GPRS class 8	32.54	32.74	32.87	30.87	30.54	30.48
GPRS class 10	29.87	30.10	30.28	29.91	29.60	29.48
GPRS class 11	27.77	27.98	28.21	27.65	27.45	27.21
GPRS class 12	26.68	26.98	27.14	25.91	25.85	25.81
EGPRS class 8	26.20	26.34	26.25	26.06	25.76	25.60
EGPRS class 10	24.65	24.18	24.37	25.77	25.71	25.29
EGPRS class 11	22.24	22.37	22.49	24.06	24.08	23.78
EGPRS class 12	21.11	21.34	21.51	21.97	21.86	21.48

Conducted Power (*Unit: dBm)			
Band	WCDMA Band II		
Channel	9262	9400	9538
Frequency	1852.4	1880	1907.6
RMC 12.2K	22.81	22.98	23.11
HSDPA Subtest-1	22.15	22.39	22.64
HSDPA Subtest-2	22.10	22.32	22.56
HSDPA Subtest-3	21.55	21.80	22.04
HSDPA Subtest-4	21.65	21.89	22.14
DC-HSDPA Subtest-1	22.13	22.36	22.62
DC-HSDPA Subtest-2	22.08	22.29	22.54
DC-HSDPA Subtest-3	21.53	21.77	22.02
DC-HSDPA Subtest-4	21.63	21.86	22.12
HSUPA Subtest-1	21.56	21.50	21.97
HSUPA Subtest-2	20.89	20.81	20.80
HSUPA Subtest-3	20.56	20.54	20.70
HSUPA Subtest-4	20.82	21.13	21.00
HSUPA Subtest-5	21.90	21.80	22.10



Peak-to-Average Ratio

Mode	GSM850		Limit: 13dB
Mod.	GSM		Result
Lowest CH	0.14		PASS
Middle CH	0.14		
Highest CH	0.20		



GSM850 (GSM)

Lowest Channel

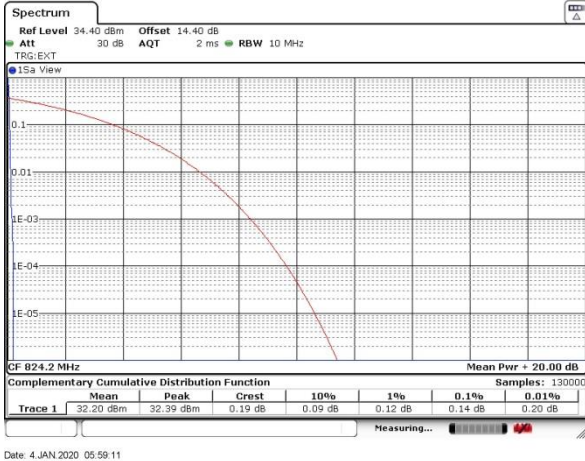

Date: 4 JAN 2020 05:59:11

Middle Channel

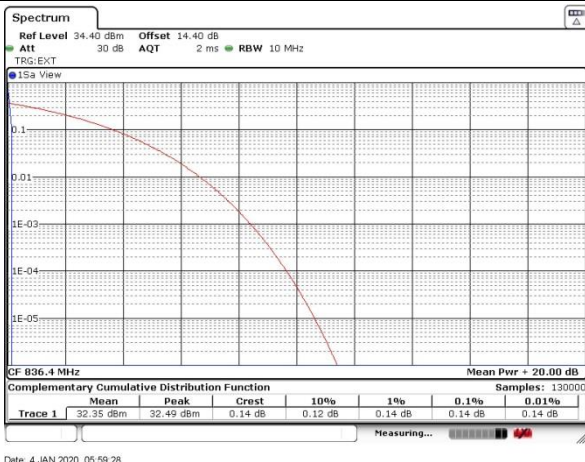

Date: 4 JAN 2020 05:59:28

Highest Channel

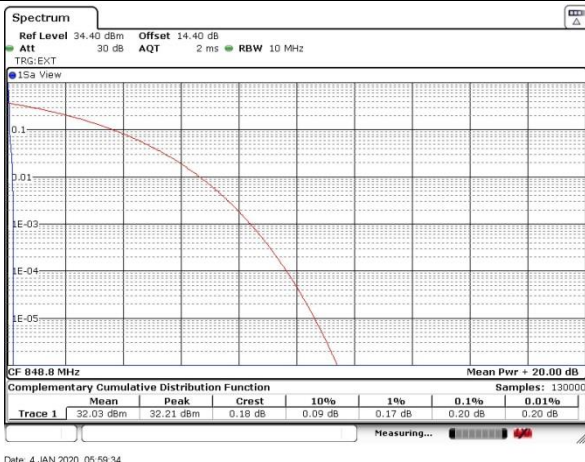

Date: 4 JAN 2020 05:59:34



26dB Bandwidth

Mode	GSM850	
Mod.	GSM	
Lowest CH	0.309	
Middle CH	0.313	
Highest CH	0.312	



GSM850 (GSM)

Lowest Channel



Date: 4 JAN 2020 05:36:26

Middle Channel

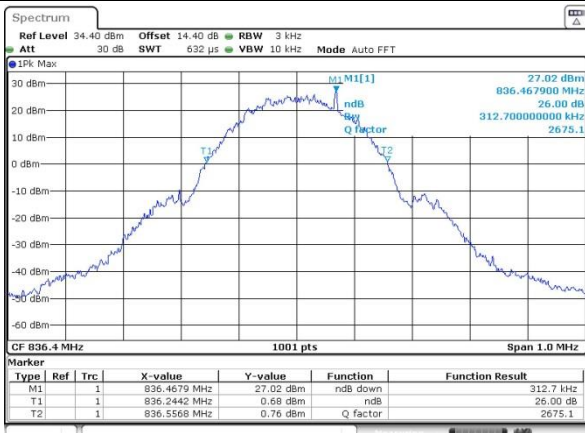

Date: 4 JAN 2020 05:36:46

Highest Channel

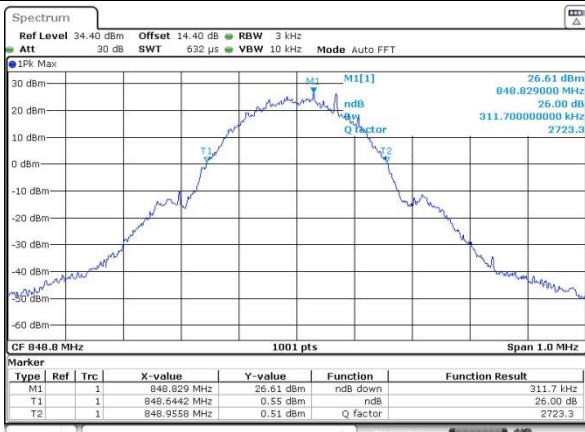

Date: 4 JAN 2020 05:37:05



Occupied Bandwidth

Mode	GSM850	
Mod.	GSM	
Lowest CH	0.241	
Middle CH	0.242	
Highest CH	0.241	



GSM850 (GSM)

Lowest Channel

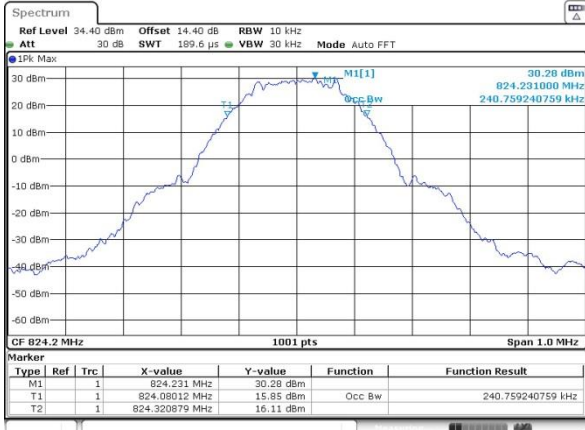

Middle Channel

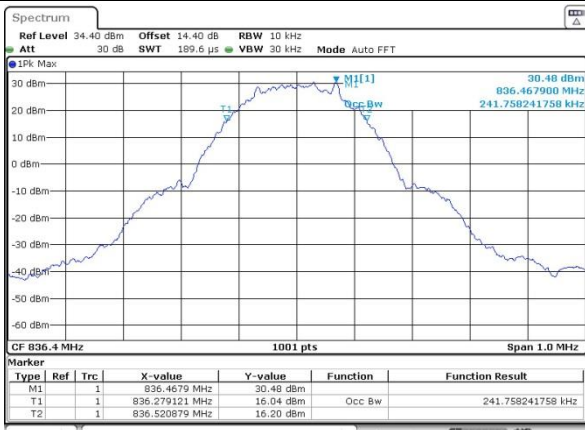

Highest Channel

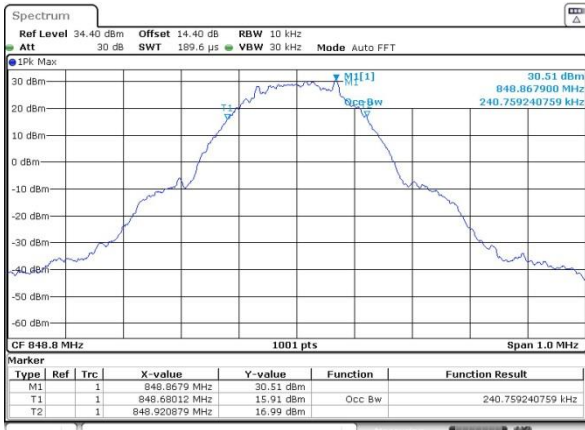



Conducted Band Edge

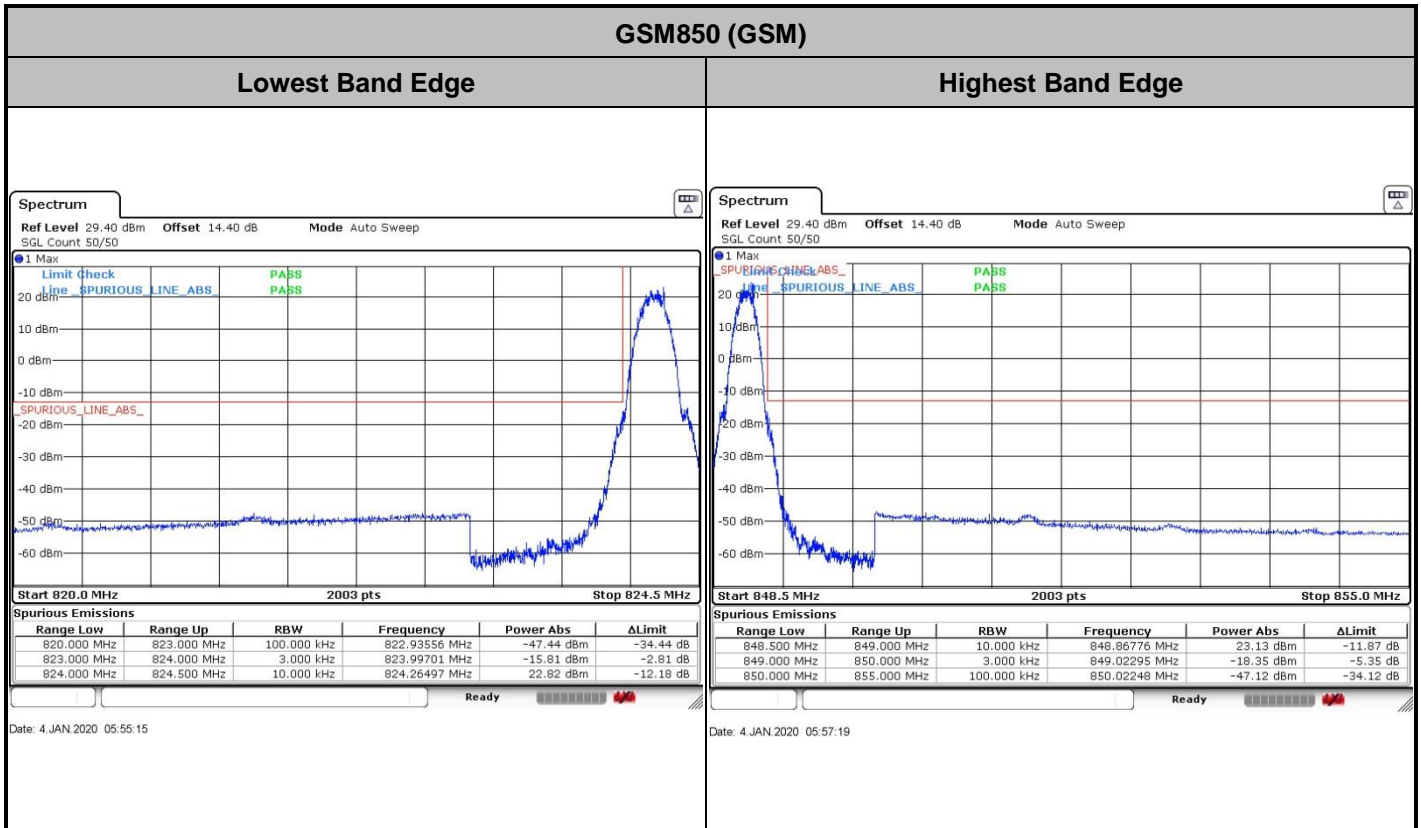



Conducted Spurious Emission

GSM850 (GSM)

Lowest Channel

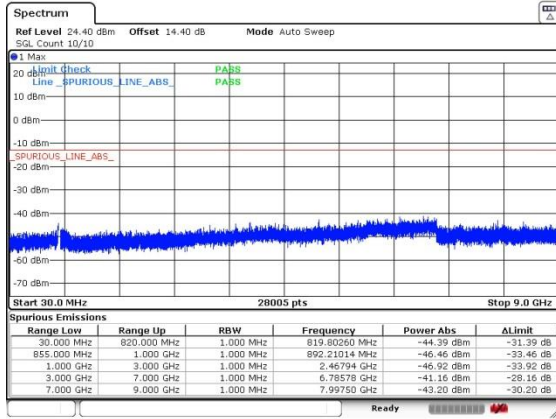

Middle Channel

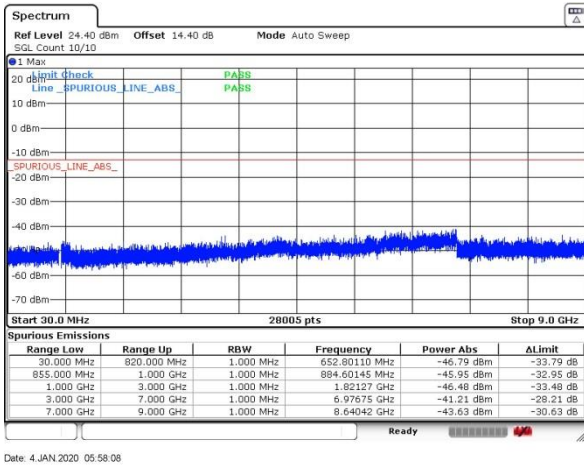

Highest Channel

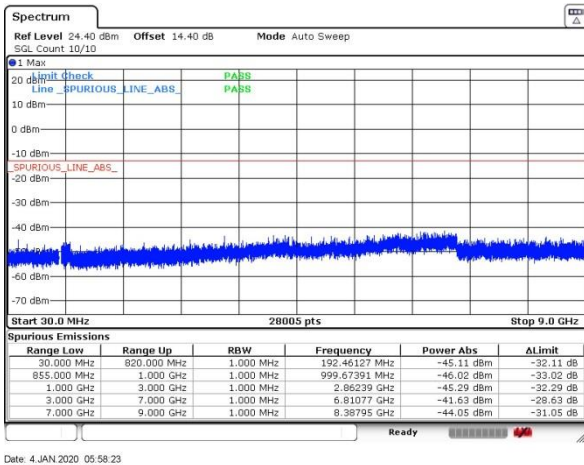



Frequency Stability

Test Conditions	Middle Channel	GSM850 (GSM)		Limit 2.5ppm
Temperature (°C)	Voltage (Volt)	Deviation (ppm)		Result
50	Normal Voltage	0.0024		PASS
40	Normal Voltage	0.0036		
30	Normal Voltage	0.0132		
20(Ref.)	Normal Voltage	0.0002		
10	Normal Voltage	0.0120		
0	Normal Voltage	0.0072		
-10	Normal Voltage	0.0024		
-20	Normal Voltage	0.0060		
-30	Normal Voltage	0.0143		
20	Maximum Voltage	0.0096		
20	Normal Voltage	0.0120		
20	Battery End Point	0.0191		

Note:

1. Normal Voltage = 3.85V ; Battery End Point (BEP) =3.45V. ; Maximum Voltage =4.35V
2. The frequency fundamental emissions stay within the authorized frequency block based on the frequency deviation measured is small.



Appendix B. Test Results of Radiated Test

Radiated Spurious Emission

GSM850 (GSM)									
Channel	Frequency (MHz)	ERP (dBm)	Limit (dBm)	Over Limit (dB)	SPA Reading (dBm)	S.G. Power (dBm)	TX Cable loss (dB)	TX Antenna Gain (dBi)	Polarization (H/V)
Middle	1672	-46.14	-13	-33.14	-49.73	-53.11	1.58	10.70	H
	2508	-52.77	-13	-39.77	-61.65	-61.02	2.102	12.50	H
	3348	-62.46	-13	-49.46	-71.79	-71.35	2.856	13.90	H
	1672	-45.77	-13	-32.77	-49.29	-52.74	1.58	10.70	V
	2508	-54.96	-13	-41.96	-63.82	-63.21	2.10	12.50	V
	3348	-60.52	-13	-47.52	-70.05	-69.41	2.86	13.90	V

Remark: Spurious emissions within 30-1000MHz were found more than 20dB below limit line.

GSM1900 (GPRS Class 8)									
Channel	Frequency (MHz)	EIRP (dBm)	Limit (dBm)	Over Limit (dB)	SPA Reading (dBm)	S.G. Power (dBm)	TX Cable loss (dB)	TX Antenna Gain (dBi)	Polarization (H/V)
Middle	3759	-48.81	-13	-35.81	-64.09	-61.07	2.64	14.90	H
	5637	-53.09	-13	-40.09	-72.19	-64.95	2.94	14.80	H
	7524	-50.37	-13	-37.37	-74.43	-60.14	3.39	13.16	H
	3762	-53.67	-13	-40.67	-69.23	-65.93	2.64	14.90	V
	5637	-53.46	-13	-40.46	-72.90	-65.32	2.94	14.80	V
	7524	-49.95	-13	-36.95	-74.67	-59.72	3.39	13.16	V

Remark: Spurious emissions within 30-1000MHz were found more than 20dB below limit line.