

Ages 14+

B ⚡ L T

USER MANUAL

BOLT



Index

Welcome	3
Disclaimer and Safety Guidelines	3
Battery Safety	4
Charging Instructions for Drone Battery	5
Pre Flight Checklist	5
Instruction for Drone, Transmitter and FPV Screen	6
Pre Flight Operation Instructions	11
Functions	17
Component Assembly	20
Spare Parts	22
Troubleshooting Guide	24

Welcome

Thank you for purchasing a Bolt drone! The Bolt is a carbon fiber drone that introduces the exciting world of First Person View (FPV) piloting and racing to everyone. Featuring an innovative FPV goggle and controller system, HD camera, altitude stabilization and a carbon fiber frame, the Bolt packs cutting edge technology at a radical price point that offers amazing value.

Before flying, please read through this User Manual carefully to ensure safe and proper operation. This product is NOT a toy and not suitable for children under the age of 14.

Disclaimer and Safety Guidelines

This product is NOT a toy and not suitable for children under the age of 14. Adults should keep the Bolt out of the reach of children and exercise caution when operating this aircraft in the presence of children.

This product is a sophisticated aircraft that offers easy flight when in good working order as set forth below. The information in this document affects your safety and your legal rights and responsibilities. Read this entire document carefully to ensure proper configuration before use. Failure to read and follow the instructions and warnings in this document may result in product loss, serious injury to you, or damage to your aircraft.

By using this product, you hereby signify that you have read this disclaimer carefully and that you understand and agree to abide by the terms and conditions herein. You agree that you are solely responsible for your own conduct while using this product, and for any consequences thereof. You agree to use this product only for purposes that are proper and in accordance with all applicable laws, rules and regulations, including international and domestic airspace regulations. Bolt Drones accepts no liability for damage, injury, or any legal responsibility incurred directly or indirectly from the use of this product. The user shall observe safe and lawful practices including, but not limited to, those set forth in these Safety Guidelines.

1.Environmental Considerations

- a. Always fly at locations that are clear of building and other obstacles
- b. DO NOT fly above or near crowds
- c. Avoid flying at altitudes above 250 feet
- d. Fly in moderate weather conditions with no wind
- e. The flying area must be a legal place of flight in accordance with local laws and regulations. Do not fly near any restricted areas including airports.

2. Genuine Parts

- a. To avoid component malfunction, serious injury and property damage, observe the following rules:
 - i. Use only genuine replacement parts from Bolt Drones. Unauthorized parts or parts from non-Bolt certified manufacturers may cause system malfunction and compromise safety
 - ii. Ensure there are no foreign objects (such as water, oil, soil, sand, etc) inside the aircraft of its components
 - iii. Ensure the aircraft and its components are all in good working order, damage-free, and functioning properly.

3. Keep away from obstacles and crowds

- a. The aircraft must be operated away from crowds, tall buildings, power lines, and other obstacles. Do not operate the aircraft in non-ideal weather conditions such as wind and rain.

4. Keep the aircraft dry

- a. The aircraft components may be damaged by water, water vapor or humidity. Please ensure aircraft is not operated in environments that may cause damage to the aircraft or its components. Make sure the aircraft is stored in a dry place

5. Pre-flight Checklist

- a. Ensure screen, remote controller and aircraft batteries are fully charged.
- b. Ensure propellers and all parts are in good condition
- c. Ensure there is nothing obstructing the motors

6. Operation

- a. Stay away from rotating propellers and motors.
- b. Maintain line of sight with your aircraft at all times
- c. DO NOT answer incoming calls or text messages during flight
- d. DO NOT fly under the influence of drugs or alcohol
- e. DO NOT fly in unfavorable weather conditions
- f. In the instance of a low battery warning, land the aircraft safely
- g. DO NOT fly near tall building, power lines or places with signal interference.
- h. DO NOT touch the motors if they are hot

7. Maintenance and Upkeep

- a. DO NOT use worn, chipped or broken propellers
- b. Only use the recommended battery charger. Check the USB cable, charging adapter and battery regularly to ensure proper functionality. If any damage is found, stop using it immediately.

Read the ENTIRE user manual to become familiar with the features of this product before operating. Failure to operate the product correctly can result in damage to the product or personal property and cause serious injury. This is a sophisticated product. It must be operated with caution and common sense and requires basic mechanical ability. Failure to operate this product in a safe and reliable manner could result in injury or damage to the product or other property. This product is not intended for use by children without direct supervision. DO NOT use with incompatible parts or alter in any manner. It is essential to read and follow all of the instructions and warnings in the user manual, prior to first flight, in order to operate the product correctly and avoid damage or serious injury

Battery Safety

- Keep the battery away from children and animals.
- Discontinue charging if you notice the battery is swollen or enlarged.
- Do not charge the battery after a crash or if there is visible damage.
- After a crash or hard landing, check the battery to ensure it has not sustained damage.
- Do not overcharge the battery.
- Do not charge the battery near flammable materials or liquids.
- Do not put the battery on near places of high temperature or heat. Store it in a proper container to avoid damage.
- Do not put the battery in a pocket or bag to where it can be scratched by sharp or metallic objects.
- Do not disassemble, refit and repair the battery.
- Do not put the battery in water and keep it in dry place.
- Do not leave the battery without supervision when charging.
- Make sure that there is no short circuit of the power wire.
- Please use the recommended charger only.
- Check the charger's wire, plug, surface regularly. Do not use any broken chargers.
- If the battery is not used more than once a week, maintain the drone battery with about 50% power to keep its performance and working life.

Charging Instructions for Drone Battery

1. Connect the drone battery or monitor battery with USB cable first and then choose one of the methods as shown below to connect with USB plug.
2. The red USB indicator lights up when charging and the light turns green when fully charged.

* For faster charging, it is recommended to use an adapter with 5V 2A output current (not included) to charge the battery.

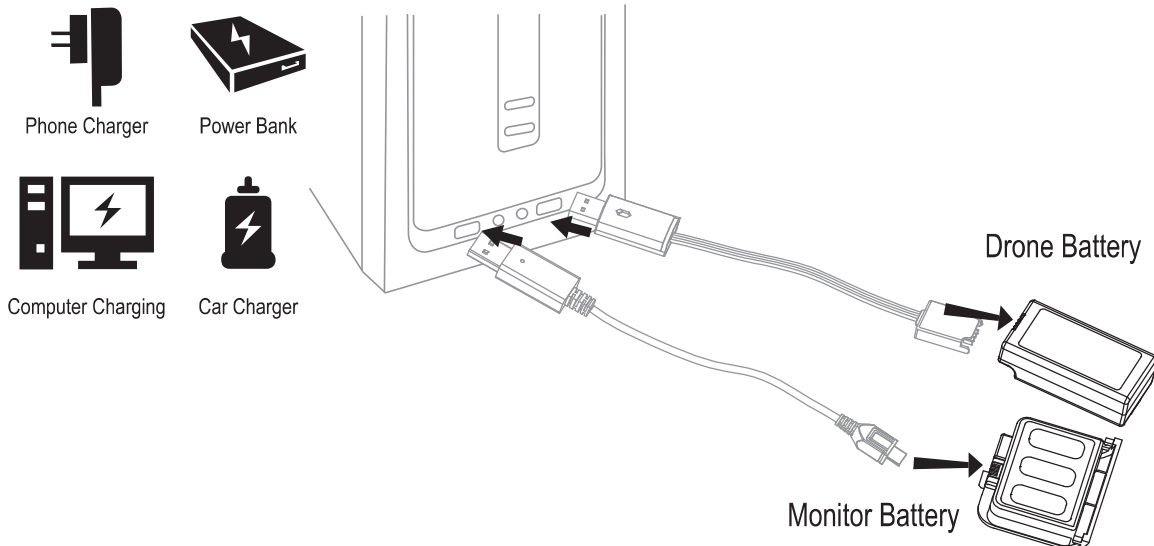

Li-Po Battery Disposal & Recycling

Lithium-Polymer batteries must not be placed with household trash.
Please contact local environmental or waste agency or the supplier of your model or your nearest Li-Po battery recycling center.



Pre Flight Checklist

1. Make sure the drone battery and transmitter battery are fully charged.
2. Make sure the Left Stick of the transmitter is in the lowest position.
3. Please follow the power on order:
 - a. Turn on the transmitter power first
 - b. Next, turn on the drone by inserting the battery. Then sync the transmitter to the drone
4. To turn off the drone, please follow the power off order:
 - a. Land the drone safely. Then, power off the drone.
 - b. Next, turn off the transmitter power when finished
5. Make sure the battery is securely plugged into the drone and that all components are functioning correctly.

Instruction for Drone, Transmitter and FPV Screen

Drone

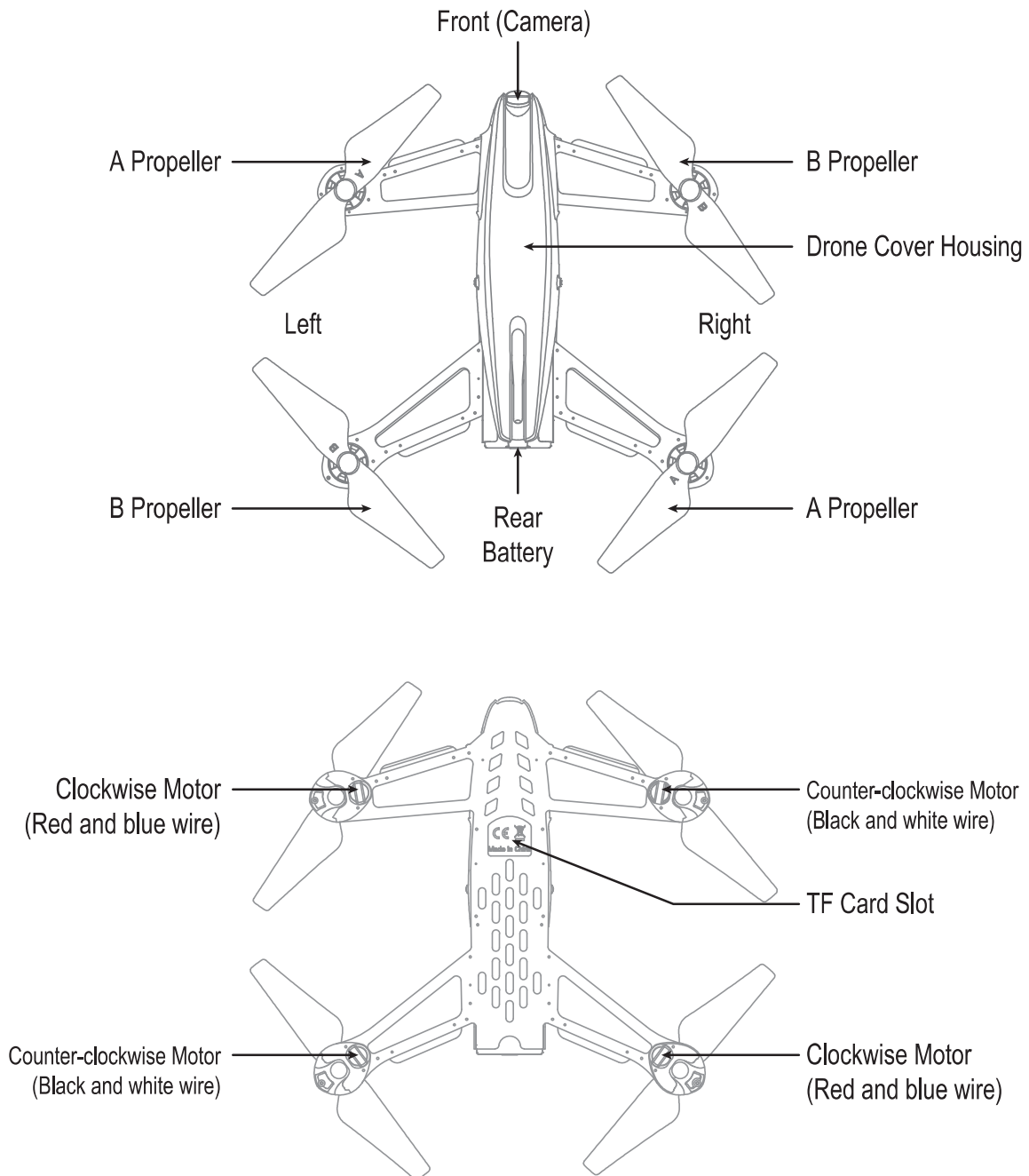

Specification

Drone Size	296x221x90.5mm	Max Flying Distance/Radius	150 m
Fly Weight	222g	Streaming Video Range	130 m
Propeller Diameter	147mm	Camera Resolution	1280x720P
Flying Time	14~16 mins	Frequency	2.4Ghz
Drone Battery	7.4V 1000mAh	Main Motor	1020x4
Charging Time for Drone Battery	150 mins	Camera Echo Frequency	5.8Ghz

Exploded View

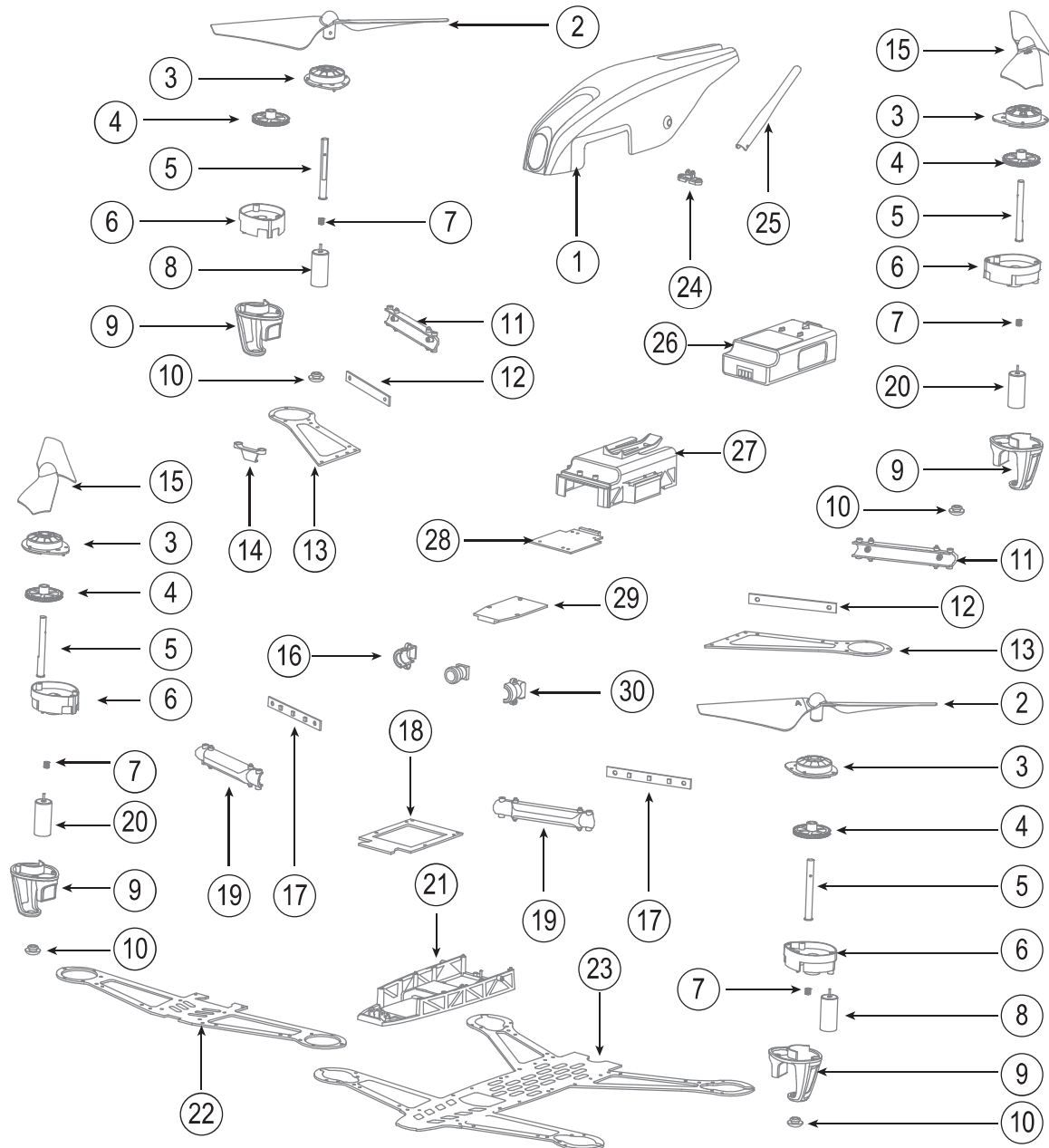

No.	Name	No.	Name	No.	Name
1	Drone Cover Housing	11	Rear LED Lampshade	21	Main Frame
2	A Propeller (Clockwise)	12	Rear LED Board (Red)	22	Front Carbon Fiber Board
3	Gear Cover	13	Rear Carbon Fiber Board	23	Bottom Carbon Fiber Board
4	Power Gear	14	Drone Cover Housing Buckle	24	Antenna Holder
5	Transmission Shaft	15	B Propeller (Counter-clockwise)	25	Antenna
6	Motor Main Frame	16	Camera Cover (Right)	26	Battery
7	Motor Gear	17	Front LED Board(White)	27	Battery Holder
8	Counter-clockwise Motor (Black and white wire)	18	Circuit Board Guard	28	Receiver Board
		19	Front LED Lampshade	29	Camera Board
9	Motor Cover	20	Clockwise Motor (Red and blue wire)	30	Camera Cover (Left)
10	Cushion				

Transmitter

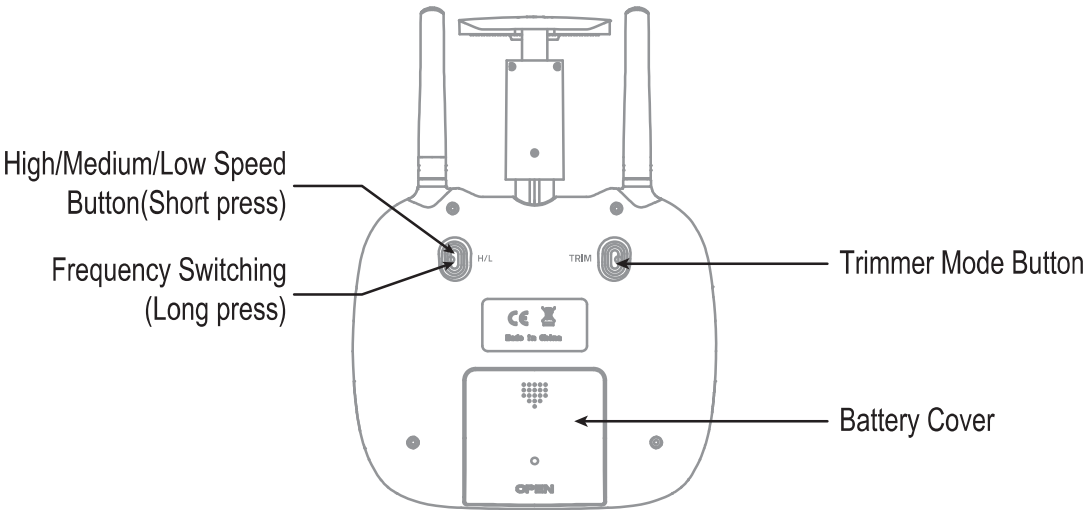
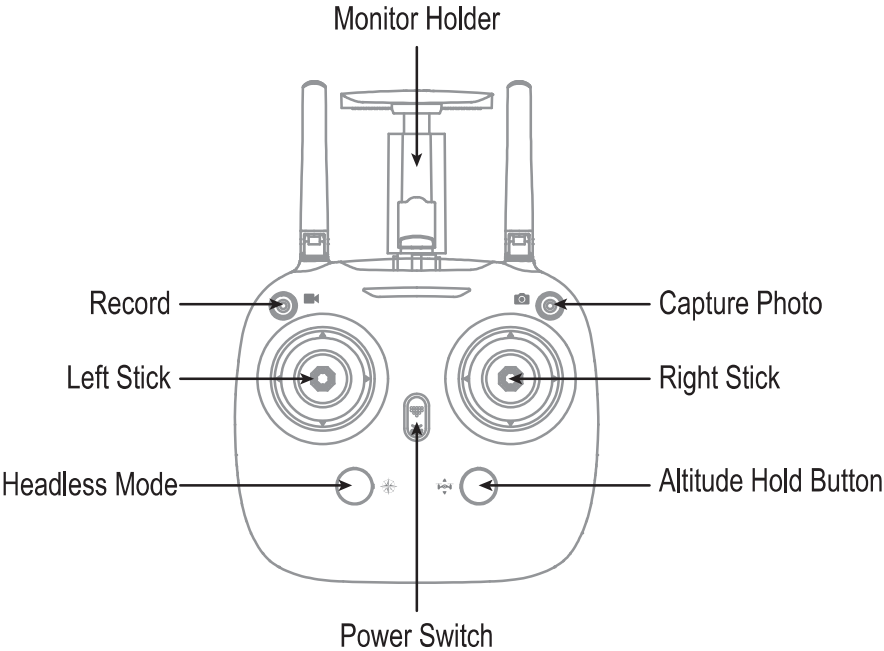

FPV Goggles

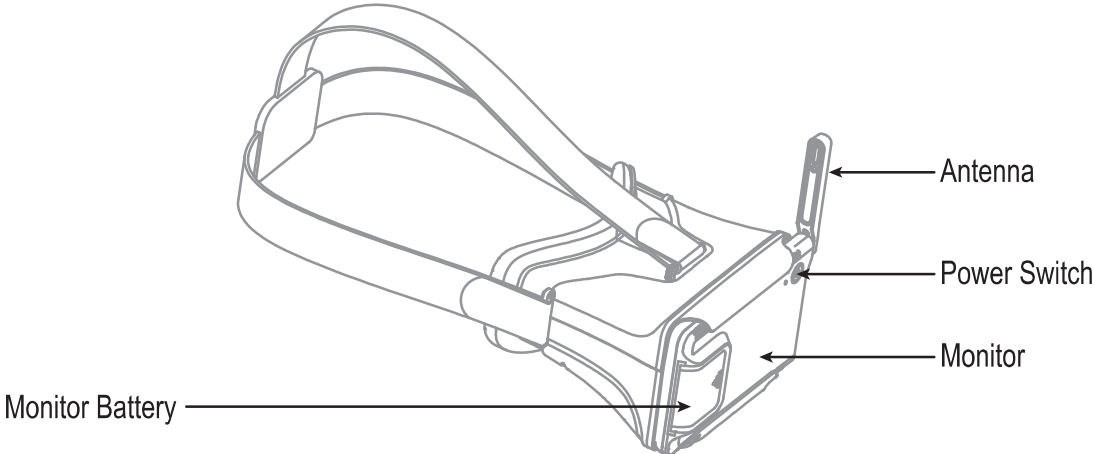

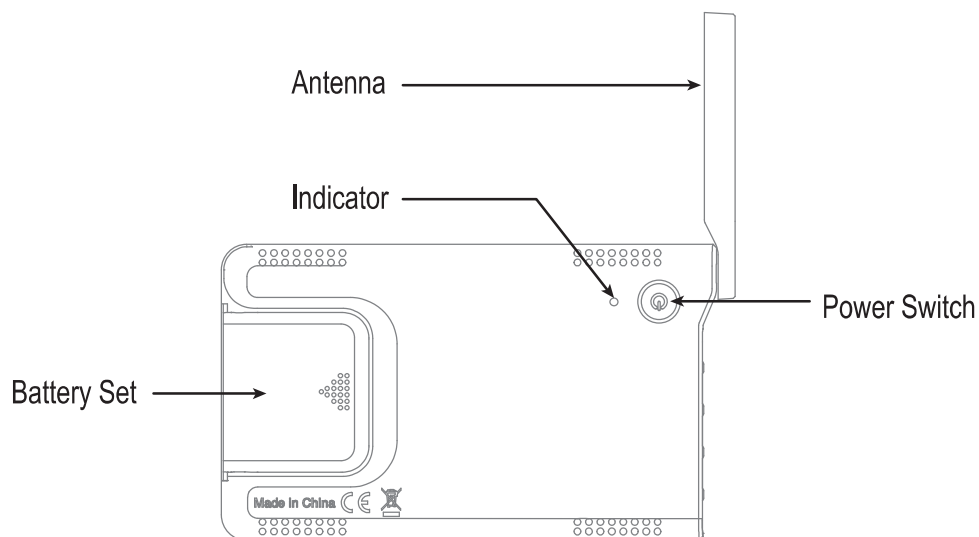
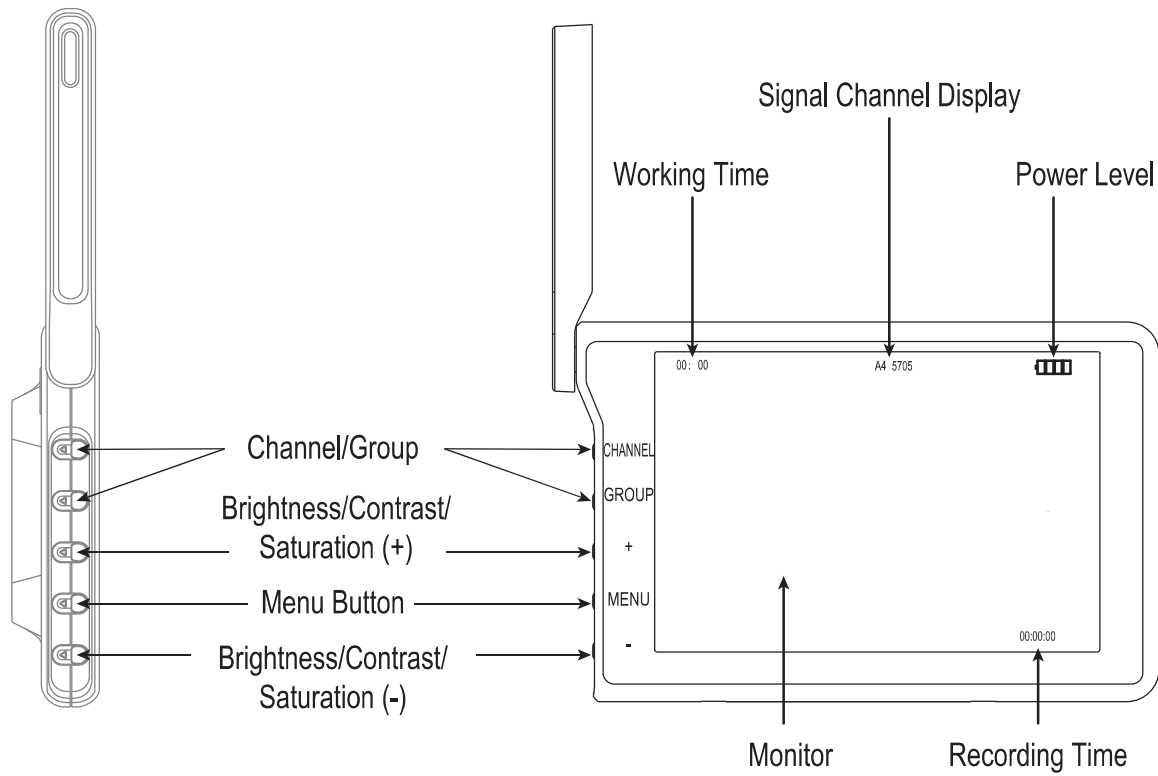

FPV Screen specification

Model	Bolt	Charging Time for VR Battery	60~80mins
Name	FPV Screen	Working Time	About 60mins
Visual Angle	120° horizon/verticality	Screen Resolution	800x480P
Headband	Elastic Headband	Contrast/Saturation	Adjustable
Brightness	Adjustable	Interpupillary Distance Adjustment	Naked eye/With wearing glasses
Weight	306g	Screen Size	5 inch
VR Size	138x147.6x93mm	Frequency/Frequency Spot	5.8G x 48
Li-po battery	3.7V x 500 mAh	Monitor Size	146x84.5x18.5mm

Introduction to Transmitter Button Functions

High/Medium/Low Speed Mode	Press down this button to switch to High/Medium/Low Speed. Long press it to switch the frequency.
Left Stick	Move the Stick forward / backward / left / right to fly the drone to up / down / turn left / turn right.
Right Stick	Move the Stick forward / backward / left / right to fly the drone to forward / backward / left / right.
Trimmer Mode Button	Press down the button, move the right stick to the required trimmer direction, then it will adjust the direction accordingly, then exit from the trimmer mode.
Power Switch	Push up the power switch to turn on the transmitter, and pull down to turn off.
Headless Mode Button	Press the button to enter headless mode, and press again to exit headless mode.
Altitude Hold Button	When the drone is flying, press down this button, and the drone will keep flying at current altitude. Press button again to turn off altitude hold.

Brief Introduction to FPV Screen Button Functions

Power Switch	Press down the Power Switch for about 3 seconds to turn on the monitor until it is bright. When you need to turn off the monitor, press down the Power Switch for about 3 seconds.
MENU	Press the "MENU" to set the parameter of the monitor
Brightness/Contrast (Plus/Minus)	Press button "+" or button "-" to increase or decrease the brightness, contrast and saturation of the monitor. In addition, use these two buttons to adjust value +/- when using the menu settings.
CHANNEL/ GROUP	Press and hold the CHANNEL or GROUP button to enter automatic search mode and keep searching according to the signal strength on different channels until you find the appropriate frequency. If search finds no frequency, it will not automatically search and all buttons cannot be operated during search process. Furthermore, click GROUP button from the channel A-F or click CHANNEL button from the channel 1-8 to select the appropriate frequency.

Battery Installation:

Open the battery cover on the back side of the transmitter and install 4 alkaline batteries (AA, not included) in accordance with the +/- direction, as picture 1 and picture 2 shown.

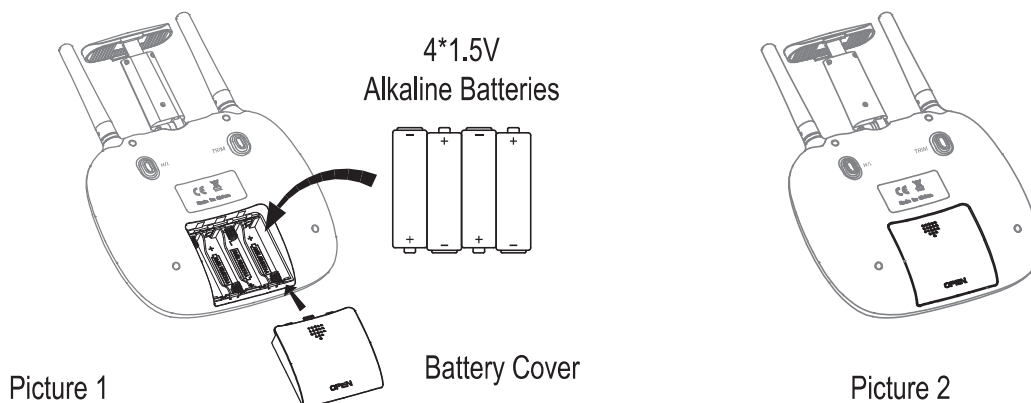

Notice:

1. Make sure the +/- directions are correct.
2. Do not mix new with old batteries.
3. Do not mix different type of batteries.

Monitor Installation Instruction:

1. Pull out the holder until the monitor can be held (Picture 3), then unfold the lower clamp (Picture 4).
2. Put the monitor into the holder, then release the clamp, and the monitor will be fixed on the holder (Picture 5/6).

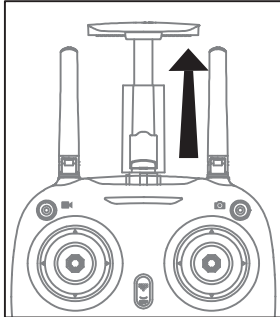

Picture 3

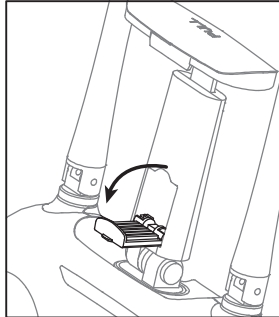

Picture 4

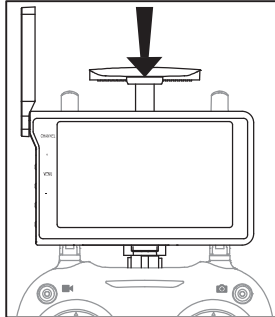

Picture 5

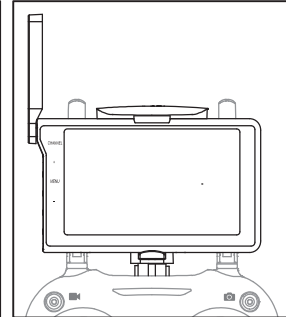

Picture 6

Pre Flight Operation Instructions

Frequency Pairing

1. Turn on the transmitter switch (Picture 7) and the power indicator light flashes rapidly. Push the Left Stick all the way up to the highest position (Picture 8) and then pull down to the lowest position (Picture 9). The power indicator light flashes slowly, which indicates the transmitter is ready for frequency pairing.

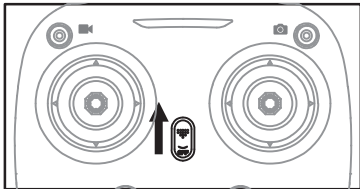

Picture 7

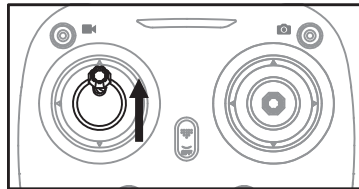

Picture 8

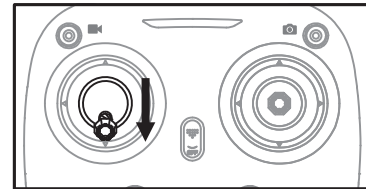

Picture 9

2. Install the Li-Po battery in accordance with the direction of arrow (Picture 10) and hear the sound of "beep," which indicates the battery is tightly installed and fixed. (Battery should be tightly fixed; otherwise, it may come loose during flight.)

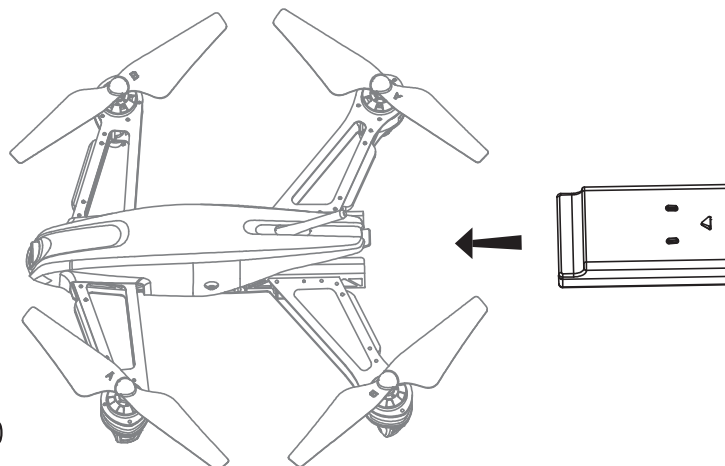

Picture 10

- Place the drone on a flat surface, the drone body lights turn from flashing to solid, which indicates frequency pairing is successful.

Important Notice: Please make sure the drone is placed on a flat, even surface when powering on.

Monitor Operation Instructions:

- Install the battery as Picture 15 shown.

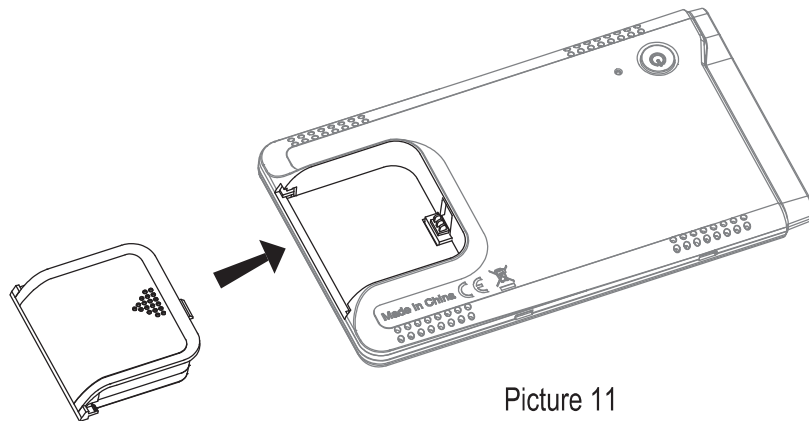

Picture 11

Warning: When the icon of power on the screen is red, it indicates that the battery is running out. Please replace the battery and charge the battery.

Notice: The buckles on both sides of the battery should attach to the monitor battery slot.

- Press down the power switch of the monitor for about 1 second, and the indicator light is solid bright (Picture 12). Then rotate the antenna of the video by 180° from front-to-rear (Picture 13/14). Press down the power switch of the monitor for about 1 second to turn off, and the indicator light is off.

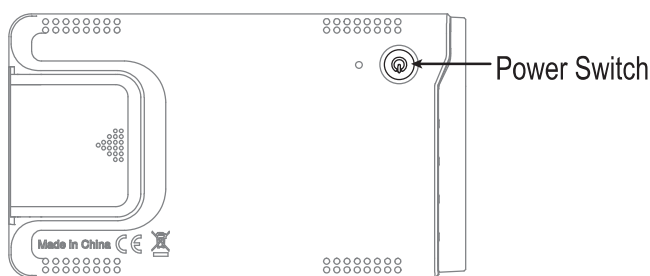

Picture 12

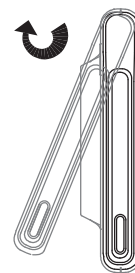

Picture 13



Picture 14

Notice: The antenna can only rotate in one direction and cannot be forced to rotate. Do not damage antenna; otherwise, the monitor signal will become shorter.

4. Press the button of CHANNEL or GROUP for about 1 second (Picture 16) to search the video frequency from the drone. The picture seen by the camera on the drone will show on the display screen when the search and sync is successful.

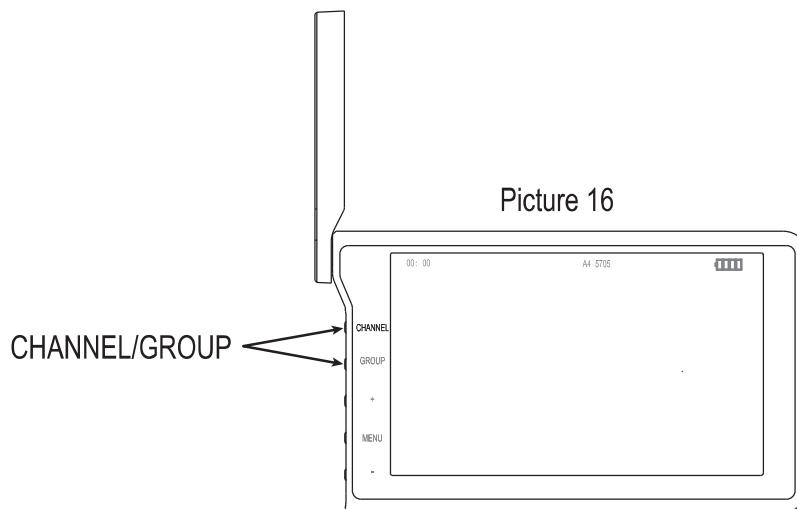

5. Press down the MENU button of the monitor. When the screen shows as picture 17, press "+" or "-" button to adjust the brightness of the screen.

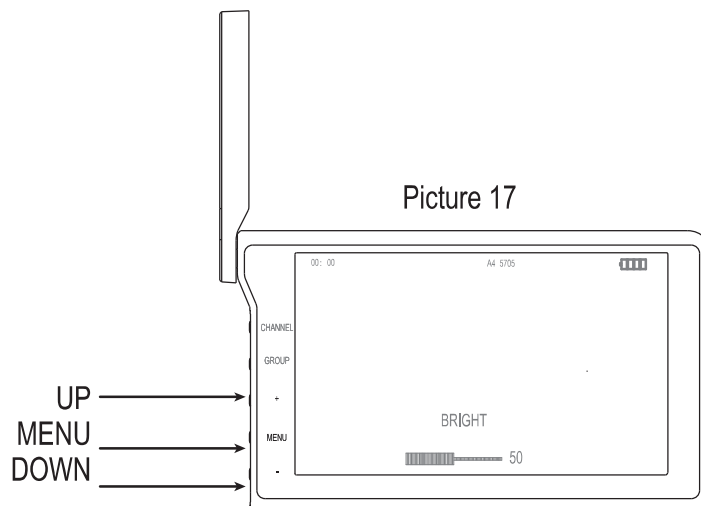

6. Once again, press down the MENU button of the video. When the screen shows as picture 18, press "+" or "-" button to adjust the contrast of the screen.

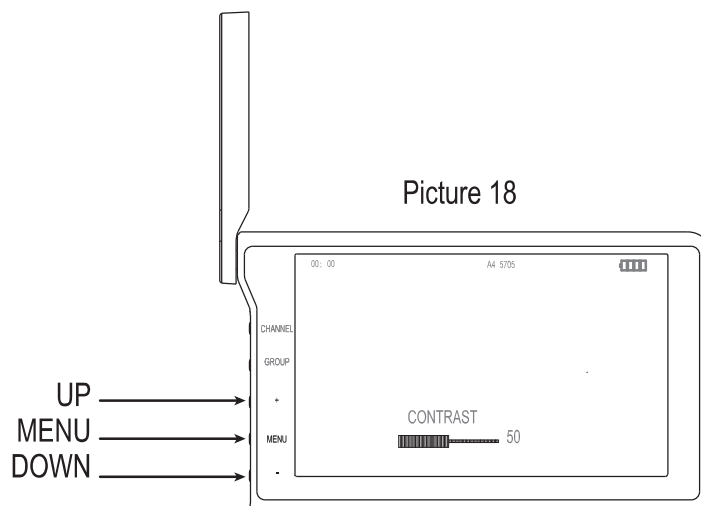

- Once again, press down the MENU button of the video. When the screen shows as picture 19, press “+” or “-” button to adjust the saturation of the screen.

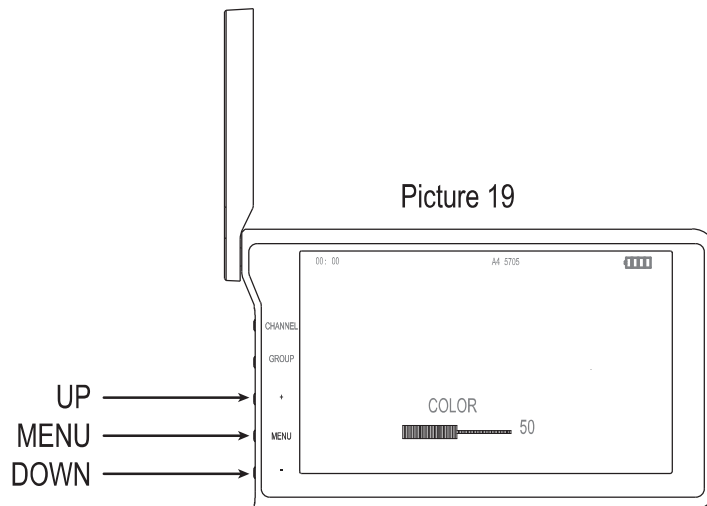

Take-off

- Make sure the camera is in forward direction of the drone.
- Power on the drone and check the direction of the rotating propellers. The left front and right rear A propellers rotate clockwise while the right front and left rear B propellers rotate counterclockwise.
- Slowly push up the Left Stick for the drone to take off. Slowly pull down the Left Stick to the lowest end for the drone to land on the ground.
- It's recommended to repeat above Step 3 to practice.
- Use the Trim button to calibrate the drone.

Calibration Instruction

Please follow below steps to calibrate the drone if the drone becomes imbalanced after crashing during the flight and cannot be adjusted by trimmer button.

- Power off the drone and remove the battery. Then, turn off the transmitter switch.
- Turn on the transmitter switch, and the power indicator light flashes rapidly. Push the Left Stick all the way up to the highest position and then pull down to lowest end (Picture 20/21). The power indicator light flashes slowly .

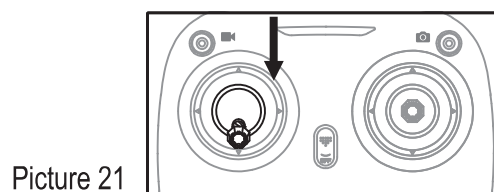
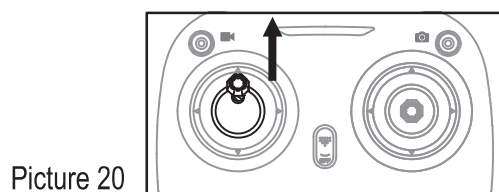

3. Install the battery and Power on the drone and place it on a flat surface in a horizontal position. The drone body lights change from flashing to solid bright, which indicates successful frequency pairing.
4. Do not move the Left Stick before successful calibration. Push the Right Stick as Picture 22 shown and then release. The drone body lights flash, which indicates that the drone is calibrating. When the drone body lights become solid it means successful calibration.

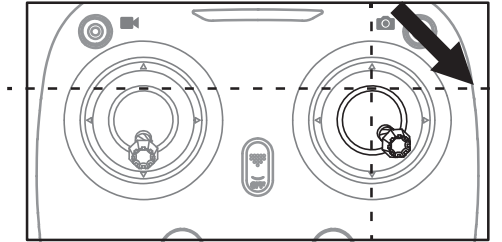

Picture 22

Notice: When the drone is crashed, it may cause the gyro sensor to become uncalibrated. You will need to power off and power on again to calibrate.

FPV Screen

1. Install the monitor into the FPV Screen (Picture 23/24).

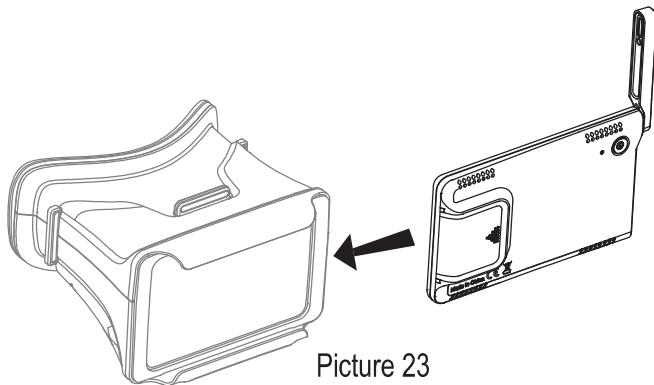

Picture 23

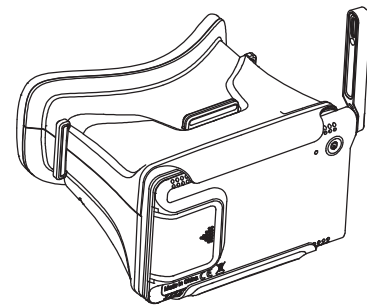

Picture 24

2. Take out the headband and put it into the FPV goggles (Picture 25), adjust the tightness of the three headbands until you feel comfortable.

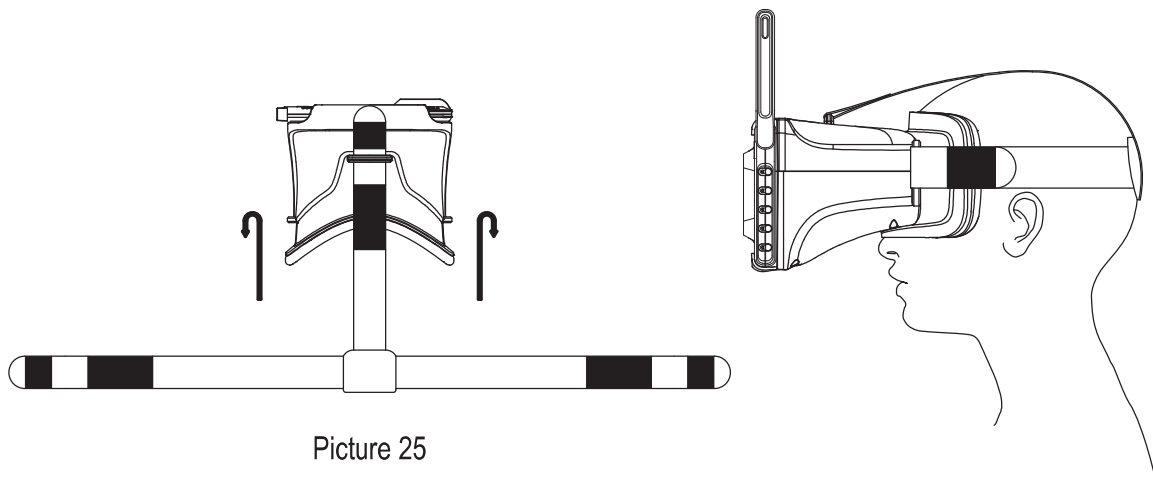

Picture 25

Flight Control

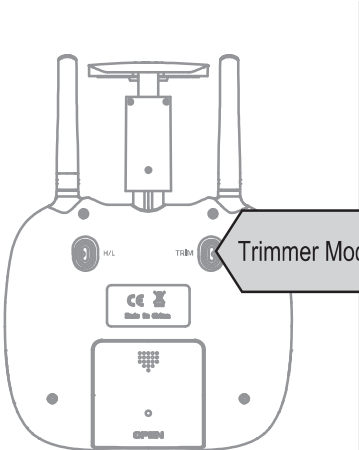
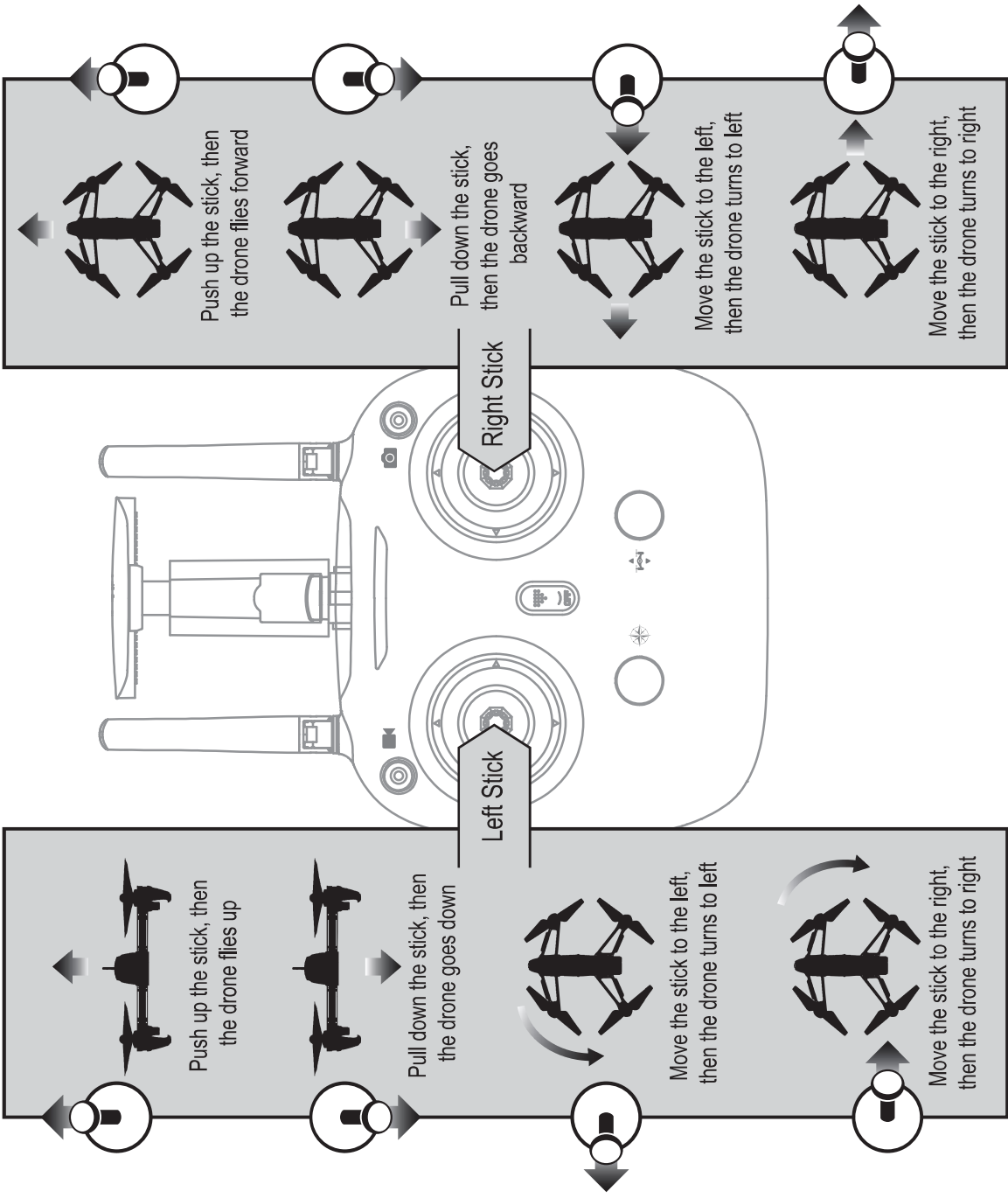

Forward and backward trimmer
 When taking off, if the drone tilts forward, press down the trimmer button, and push the right stick backwards. Otherwise push forwards.

Left and right side flying trimmer
 When taking off, if the drone tilts to left, press down the trimmer button and push the right stick to right. Otherwise push to left.

Left and right turning trimmer
 When taking off, if the drone head rotates to left, press down the trimmer button and push the left stick to right. Otherwise push to left.

Functions

Altitude Hold Mode

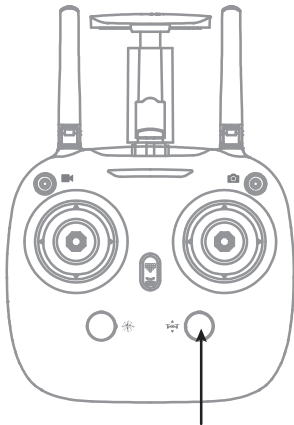

Altitude Hold Button

When the drone is flying, press down the Altitude Hold Button to enter Altitude Hold Mode (the front and rear lights of the drone flash two times in three seconds). Then the drone will keep flying at current altitude. It makes it easier to control the drone for beginners and gives stability for photography. At the end of each flight, the function of altitude hold will automatically exit.

High/Medium/Low Speed Modes

Press down this button. When it sounds one “beep,” it is on low speed mode “L.” When it sounds two “beeps,” it is on medium speed “M.” When it sounds three “beeps,” it is on high speed mode “H.” (The default setting is medium speed mode “M.”)

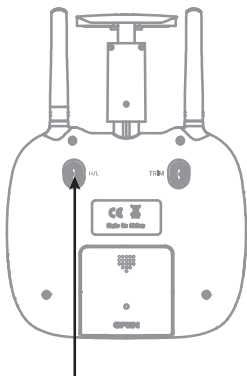

High/Medium/Low Speed Button (Short press)

1. Low Speed Mode “L” - One “Beep”
Low Speed Mode is suitable for beginner.
2. Medium Speed Mode “M” - Two “Beeps”
Medium Speed Mode is suitable for intermediate pilots.
3. High Speed Mode “H” - Three “Beeps”
High Speed Mode is suitable for expert pilots.

Frequency Switch

Press down the button for about 2 seconds to switch frequency. (The monitor should re-search the new frequency to see the graphics normally.)

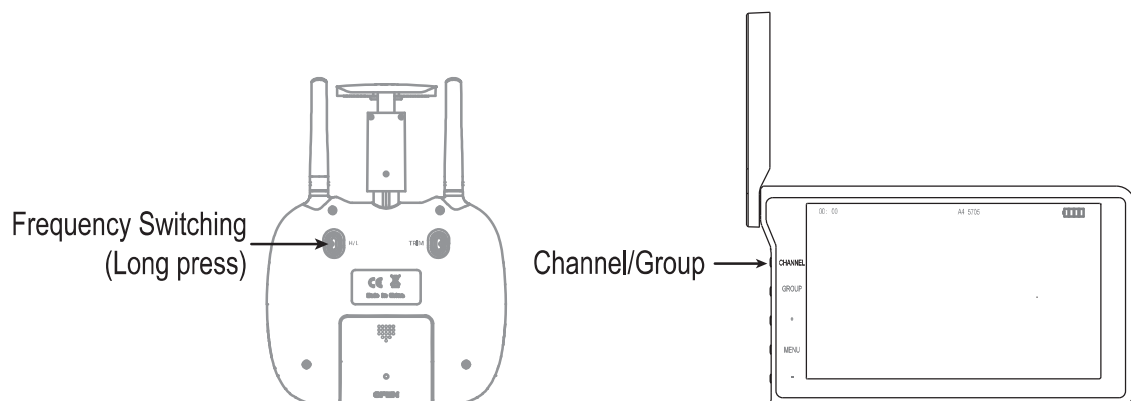

Frequency

GROUP \ CHANNEL	CH1	CH2	CH3	CH4	CH5	CH6	CH7	CH8
Fr A	5645	5665	5685	5705	5885	5905	5925	5945
Fr B	5740	5760	5780	5800	5820	5840	5860	5880
Fr C	5725	5745	5765	5785	5805	5825	5845	5865
Fr D	5733	5752	5771	5790	5809	5828	5847	5866
Fr E	5658	5695	5732	5769	5806	5843	5880	5917
Fr F	5362	5399	5436	5473	5510	5547	5584	5621

Video Record Button

Make sure that you insert the TF card. Press down the button to record the video, and the recording time will begin to flash. Press down the button to stop recording. The video will be stored in the TF card of the drone.

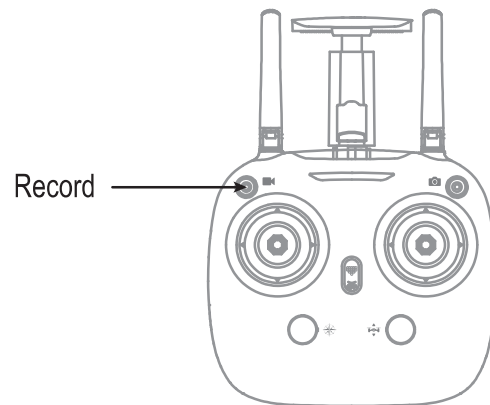
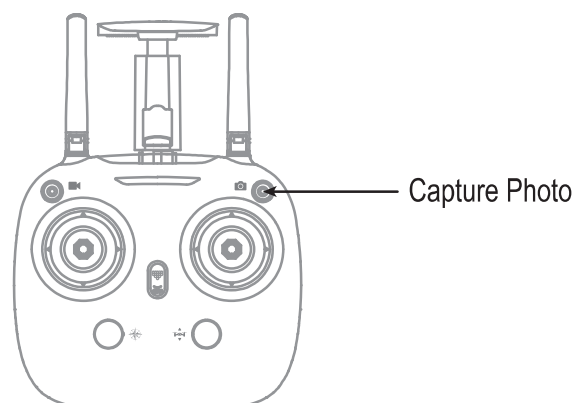

Photo Button

Make sure that you insert the TF card. Press down the button to take a picture. Hold down the button to continuously take multiple photos. The photo will be saved in the TF card of the drone.



Headless Mode

Under headless mode, the users can operate the drone without worrying about the orientation (left is left and right is right all the time, regardless of where your drone is pointing at). Headless Mode is designed for beginners and users who fly the drone in daylight or at a far distance.

The default setting is NOT Headless Mode.

You can activate the headless mode function before taking off or in flight. When flying under headless mode, you are required to ensure that the drone's front direction is aligned with your front direction. **DO NOT** change the direction of your transmitter and keep it in front of you at all times.

Warning: Do not use headless mode before you are sure that the drone's front is your front. Otherwise, it might be out of control or fly away.

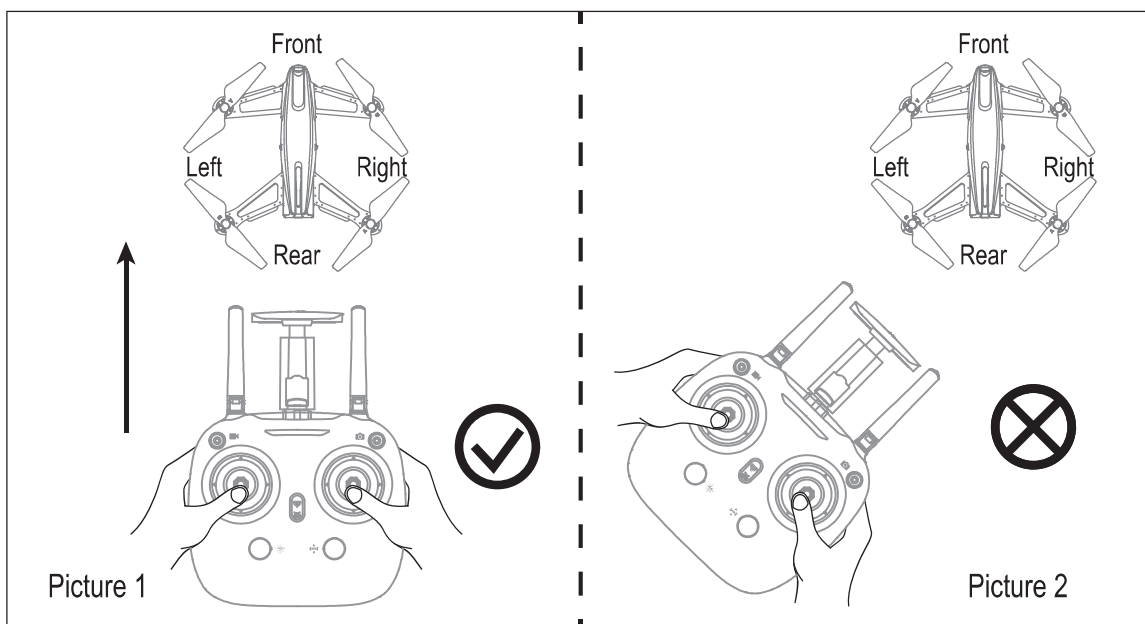

* Press down Headless Mode button, and the drone's left and right LED will start flashing alternately. It indicates the drone entering Headless Mode. Press the button again, then the LED becomes solid, and the drone will exit from Headless Mode.

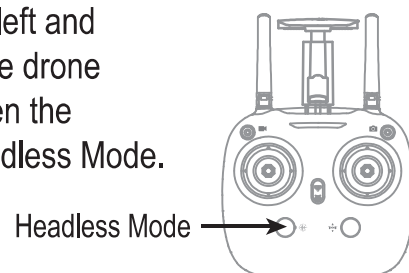

Low Battery Alarm

When the transmitter is in low battery, the transmitter will beep twice to remind the user to land the drone to replace the batteries as soon as possible.

When the drone is in low battery, the transmitter will beep constantly to remind the user to land the drone as soon as possible. The flip function will turn off automatically when the drone is in low battery.

Out of Range Warning

When the drone is going to fly out of the max remote control distance, the transmitter will beep quickly to alarm the user to fly the drone back immediately.

Motors Jam Protection

1. When the propellers get stuck, the drone LED will flash quickly and activate stuck protection function and the motors will stop running.
2. Pull down the Left Stick to the lowest position. The drone LED becomes a solid light and stuck protection will be released, and the drone can fly again.

Component Assembly

Propeller Installation Diagram

1. When disassembling, use the screwdriver to remove the screw on the propeller, then take out the propeller (picture 26).
2. When assembling, first mount propeller on transmission shaft of the drone, then fix the screws on the propeller (picture 27).

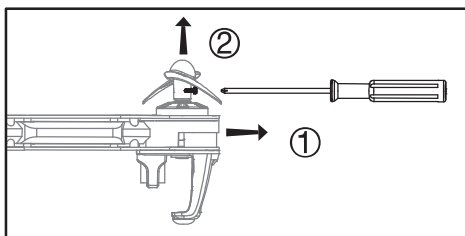

Picture 26

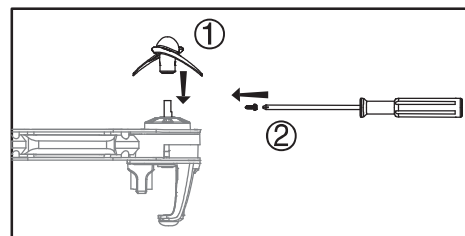

Picture 27

Motors Replacement Diagram

1. Use the attached screwdriver to remove the screws on motor holder (Picture 28), pull out the motor frame, unplug the motor connector, and then take out the motor.

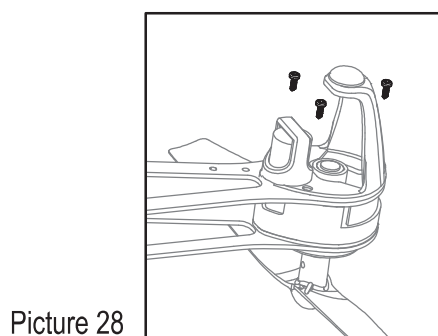

Picture 28

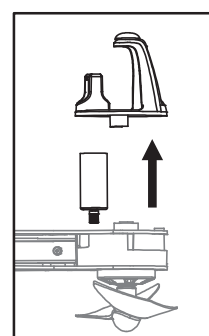

Picture 29

- Put the motor into motor holder (Picture 30), connect motor wire, install the frame, then fix the screw.

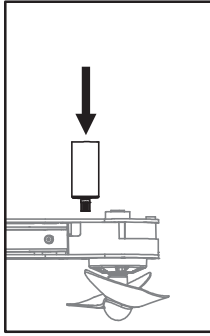

Picture 30

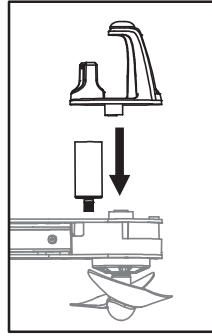

Picture 31

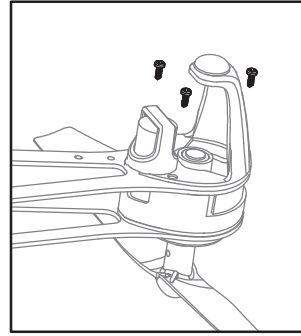

Picture 32

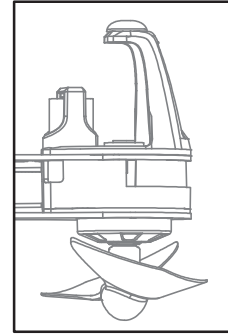

Picture 33

Notice: The motor's rotating direction should be the same, or it will not work.

Battery Installation Diagram

When disassembling, you need to lift up the battery buckle (direction as Picture 34) and then pull out the battery (refer to Picture 10).

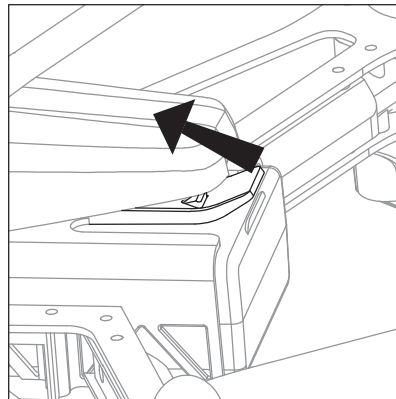

Picture 34

To take photos and record video

- Insert the TF card to the slot in accordance with Picture 35. Make sure the metal side of the card faces up as the picture.

- The aerial photo and video will be saved in the TF card.

Tip: Click on the video icon to store a video when ending recording, or the video cannot be saved.

- Power off the drone when finished with aerial photography.

Take out TF card and insert the card to a card reader.

Connect the card reader with computer USB port. After a while, view the aerial photography data from "my computer"- "mobile disk."

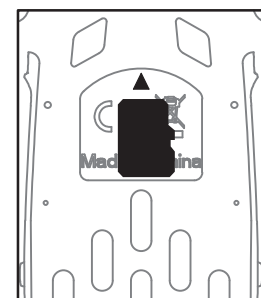

Picture 35

Tip: Please play the video or photo after copying all aerial photography data to computer and make sure the software can support AVI format.

Basic parameters for camera: Video DPI 1280*720P
Image Size 1280*720P

Spare Parts

For convenience, the spare parts are listed for you to choose, which can be purchased directly from BoltDrones.com.

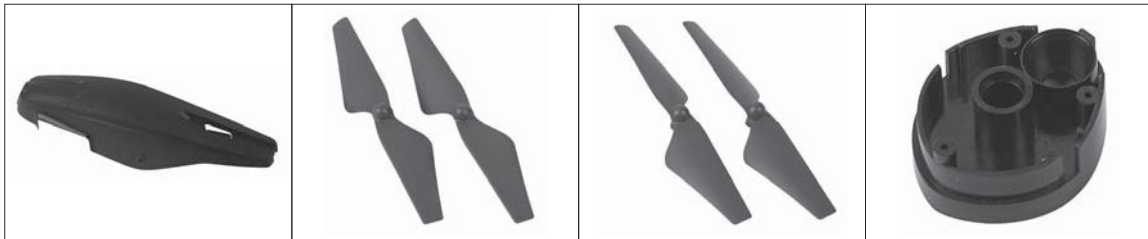

BD34-01
Drone Cover Housing

BD34-02
A Propeller

BD34-03
B Propeller

BD34-04
Motor Holder



BD34-05
Motor Cover

BD34-06
Battery

BD34-07
Battery Holder

BD34-08
Main Frame



BD34-09
Camera Cover
(left)

BD34-10
Camera Cover
(right)

BD34-11
Antenna

BD34-12
Antenna Holder

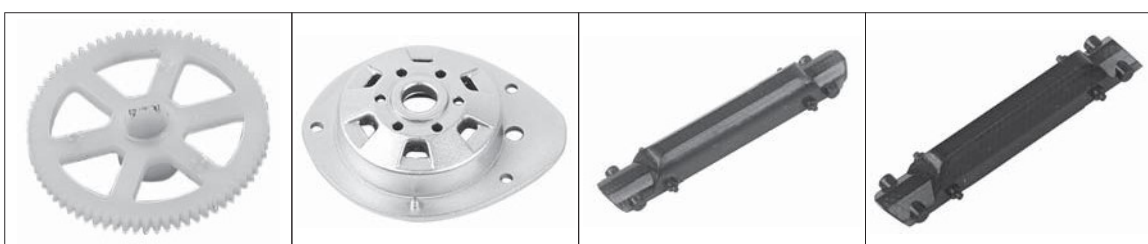

BD34-13
Transmission Gear

BD34-14
Gear Cover

BD34-15
Front Lampshade

BD34-16
Rear Lampshade

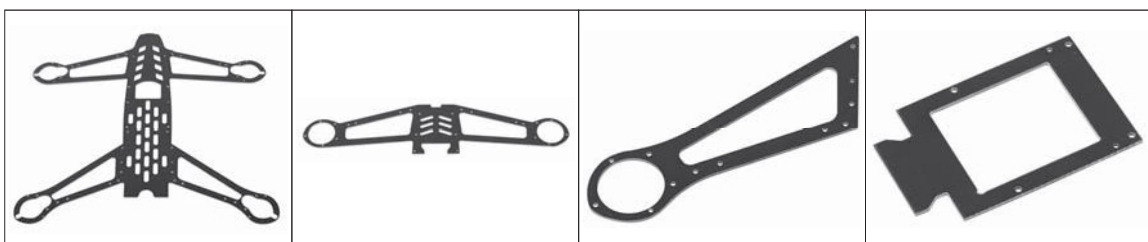

BD34-17
Bottom Carbon
Fiber Board

BD34-18
Front Carbon
Fiber Board

BD34-19
Rear Carbon
Fiber Board

BD34-20
Circuit Board Guard



BD34-21
Clockwise Motor
(Red and blue wire,
red connector)



BD34-22
Counter-clockwise Motor
(Black and white wire,
white connector)



BD34-23
Front LED Board
(White)



BD34-24
Rear LED Board
(Red)

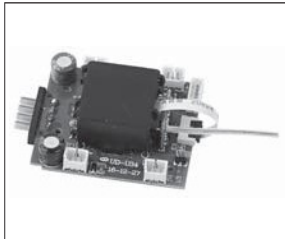

BD34-25
Receiver Board

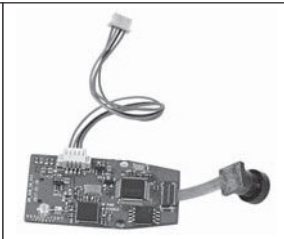

BD34-26
Camera Board



BD34-27
Camera Board Antenna



BD34-28
Camera Board Antenna



BD34-29
Camera Lens Cushion



BD34-30
Transmission Shaft



BD34-31
Bearing



BD34-32
USB Cable



BD34-33
TF Card



BD34-34
Card Reader



BD34-35
Wrench



BD34-36
Screwdriver



BD34-37
Transmitter



BD34-38
VR3



BD34-39
VR3 LIPO Battery



BD34-40
VR3 Charger



BD34-41
Headband

Troubleshooting Guide

No.	Problem	Problem Cause	Solution
1	The transmitter indicator light is off	1. Low battery.	1. Replace the transmitter battery.
		2. The battery positive pole and negative pole are in reverse order.	2. Install the battery in accordance with the user manual.
		3. Poor Contact.	3. Clean the dirt between the battery and the battery slice.
2	Fail to pair the drone with transmitter	1. Indicator light is off.	1. The same as above 1.2.3.
		2. There is interfering signal nearby.	2. Restart the drone and power on the transmitter.
		3. Misoperation.	3. Operate the drone step by step in accordance with the user manual.
		4. The electronic component is damaged from frequent crash	4. Replace damaged parts.
3	The drone is under-powered or can not fly.	1. The propeller is damaged.	1. Replace the propeller.
		2. Low battery.	2. Recharge the drone battery.
		3. Incorrect installation of propeller.	3. Install the propeller in accordance with the user manual.
4	The drone cannot hover and tilts to one side	1. Poor calibration.	1. Refer to the instruction of calibration.
		2. The propeller deformed.	2. Replace propeller.
		3. The motor holder deformed.	3. Replace the motor holder.
		4. The gyro did not reset after violent crash.	4. Put the drone on the flat ground for about 10s or restart the drone to calibrate again.
		5. The motor is damaged.	5. Replace motor.
5	The drone indicator light is off	1. Low battery.	1. Recharge the drone battery.
		2. The battery is expired.	2. Replace with new battery.
		3. Poor contact.	3. Disconnect the battery and then connect it with the plug again.
6	Cannot see the picture	1. Not in the correct frequency.	1. Press the frequency search button to search the frequency.
		2. Damaged camera.	2. Replace with new camera.

FCC Note

This equipment has been tested and found to comply with the limits for a Class B digital device, pursuant to Part 15 of the FCC Rules. These limits are designed to provide reasonable protection against harmful interference in a residential installation. This equipment generates uses and can radiate radio frequency energy and, if not installed and used in accordance with the instructions, may cause harmful interference to radio communications. However, there is no guarantee that interference will not occur in a particular installation. If this equipment does cause harmful interference to radio or television reception, which can be determined by turning the equipment off and on, the user is encouraged to try to correct the interference by one or more of the following measures:

- Reorient or relocate the receiving antenna.
- Increase the separation between the equipment and receiver.
- Connect the equipment into an outlet on a circuit different from that to which the receiver is connected.

WARNING: Changes or modifications not expressly approved by the party responsible for compliance could void the user's authority to operate the equipment.

FCC Notice:

The equipment may generate or use radio frequency energy. Changes or modifications to this equipment may cause harmful interference unless the modifications are expressly approved in the instruction manual. Modifications not authorized by the manufacturer may void user's authority to operate this device.

This device complies with Part 15 of the FCC Rules. Operation is subject to the following two conditions:

- (1) This device may not cause harmful interference.
- (2) This device must accept any interference received, including interference that may cause undesired operation.



MADE IN CHINA

www.boltdrones.com