

# Test Report

## FCC Part15 Subpart B

Product Name : GPS Tracker  
Model No. : PRIME AT (VL1000)

Applicant : Micron Electronics LLC  
Address : 601 N. Congress Ave, Suite 439

Date of Receipt : 16/06/2011  
Test Date : 16/06/2011~22/06/2011  
Issued Date : 22/06/2011  
Report No. : 116S045R-HP-US-P01V02  
Report Version : V 1.0

The test results relate only to the samples tested.

The test results shown in the test report are traceable to the national/international standard through the calibration of the equipment and evaluated measurement uncertainty herein.

This report must not be used to claim product endorsement by TAF, NVLAP or any agency of the Government.

The test report shall not be reproduced except in full without the written approval of QuieTek Corporation.

# Test Report Certification

Issued Date: 22/06/2011

Report No.: 116S045R-HP-US-P01V02



Product Name : GPS Tracker  
 Applicant : Micron Electronics LLC  
 Address : 601 N. Congress Ave, Suite 439  
 Manufacturer : Shanghai Simcom Ltd.  
 Address : Building A, SIM Technology Building, No.633, Jinzhong Road, Changning District, Shanghai P.R. China 200335  
 Model No. : PRIME AT (VL1000)  
 EUT Voltage : MIN: 3.6V, NOR: 3.7V, MAX: 4.2V  
 Brand Name : PRIME  
 Applicable Standard : FCC Part 15 Subpart B: 2008 Class B/ANSI C63.4: 2009  
 Test Result : Complied  
 Performed Location : Suzhou EMC Laboratory  
 No.99 Hongye Rd., Suzhou Industrial Park Loufeng Hi-Tech Development Zone., Suzhou, China  
 TEL: +86-512-6251-5088 / FAX: +86-512-6251-5098

Documented By : Alice Ni  
 (Engineering ADM: Alice Ni)

Reviewed By : Robin Wu  
 (Senior Engineer: Robin Wu)

Approved By : Marlin Chen  
 (Engineering Supervisor: Marlin Chen)

## Laboratory Information

We, **QuietTek Corporation**, are an independent EMC and safety consultancy that was established the whole facility in our laboratories. The test facility has been accredited/accepted(audited or listed) by the following related bodies in compliance with ISO 17025, EN 45001 and specified testing scope:

<b>Taiwan R.O.C.</b>	<b>: BSMI, NCC, TAF</b>
<b>Germany</b>	<b>: TUV Rheinland</b>
<b>Norway</b>	<b>: Nemko, DNV</b>
<b>USA</b>	<b>: FCC, NVLAP</b>
<b>Japan</b>	<b>: VCCI</b>

The related certificate for our laboratories about the test site and management system can be downloaded from QuietTek Corporation's Web Site : <http://www.quietek.com/tw/ctg/cts/accreditations.htm>  
 The address and introduction of QuietTek Corporation's laboratories can be founded in our Web site : <http://www.quietek.com/>  
 If you have any comments, Please don't hesitate to contact us. Our contact information is as below:

### HsinChu Testing Laboratory :

No.75-2, 3rd Lin, Wangye Keng, Yonghxing Tsuen, Qionglin Shiang, Hsinchu County 307, Taiwan, R.O.C.  
 TEL:+886-3-592-8858 / FAX:+886-3-592-8859 E-Mail : [service@quietek.com](mailto:service@quietek.com)



### LinKou Testing Laboratory :

No. 5-22, Ruei-Shu Valley, Ruei-Ping Tsuen, Lin-Kou Shiang, Taipei, Taiwan, R.O.C.  
 TEL : 886-2-8601-3788 / FAX : 886-2-8601-3789 E-Mail : [service@quietek.com](mailto:service@quietek.com)



### Suzhou (China) Testing Laboratory :

No. 99 Hongye Rd., Suzhou Industrial Park Loufeng Hi-Tech Development Zone., Suzhou,China.  
 TEL : +86-512-6251-5088 / FAX : +86-512-6251-5098 E-Mail : [service@quietek.com](mailto:service@quietek.com)



**TABLE OF CONTENTS**

Description	Page
1. General Information.....	5
1.1. EUT Description .....	5
1.2. Mode of Operation.....	6
1.3. Tested System Details .....	7
1.4. Configuration of Tested System.....	8
1.5. EUT Exercise Software.....	9
2. Technical Test.....	10
2.1. Summary of Test Result.....	10
2.2. List of Test Equipment .....	11
2.3. Measurement Uncertainty.....	12
2.4. Test Environment.....	13
3. Conducted Emission .....	14
3.1. Test Specification.....	14
3.2. Test Setup .....	14
3.3. Limit.....	14
3.4. Test Procedure .....	14
3.5. Deviation from Test Standard.....	15
3.6. Test Result.....	16
3.7. Test Photograph .....	20
4. Radiated Emission .....	21
4.1. Test Specification.....	21
4.2. Test Setup .....	21
4.3. Limit.....	22
4.4. Test Procedure .....	22
4.5. Deviation from Test Standard.....	23
4.6. Test Result.....	24
4.7. Test Photograph .....	32
5. Attachment .....	34
EUT Photograph.....	34

## 1. General Information

### 1.1. EUT Description

Product Name	GPS Tracker
Brand Name	PRIME
Model No.	PRIME AT (VL1000)
Working Voltage	MIN: 3.6V, NOR: 3.7V, MAX: 4.2V
GPS Function	Yes
Tx Frequency Range	GSM 850: 824MHz to 849MHz PCS 1900: 1850MHz to 1910MHz
Rx Frequency Range	GSM 850: 869MHz to 894MHz PCS 1900: 1930MHz to 1990MHz
Type of modulation	GMSK
Peak Antenna Gain	0dBi
AC Adapter	Manufacturer: SHENZHEN SUPERWORLD ELECTRONIC TECHNOLOGICAL CO.,LTD M/N: SW013UF-0500200US Input: 100-240V~50/60Hz 0.4A Output: DC 5V, 2A

**1.2. Mode of Operation**

QuieTek has verified the construction and function in typical operation. All the test modes were carried out with the EUT in normal operation, which was shown in this test report and defined as:

Test Mode
Mode 1: Charging + GPS receive
Mode 2: software update by USB Port

**1.3. Tested System Details**

The types for all equipments, plus descriptions of all cables used in the tested system (including inserted cards) are:

Product		Manufacturer	Model No.	Serial No.	Power Cord
1	Notebook	DELL	E520	N/A	Non-Shielded, 1.8m

### 1.4. Configuration of Tested System

Connection Diagram (Mode1)

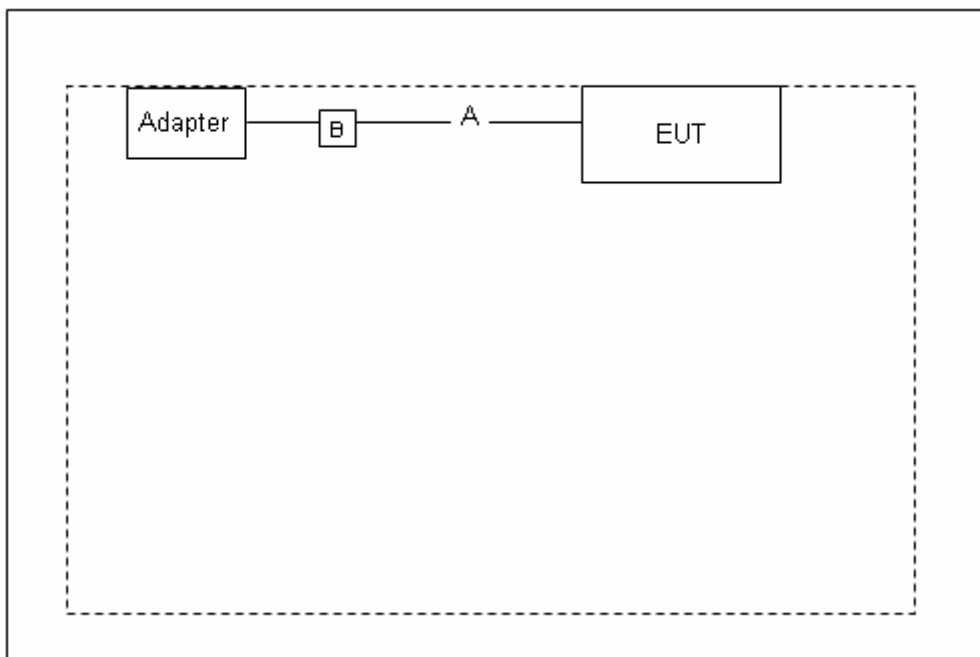

Connection Diagram (Mode2)

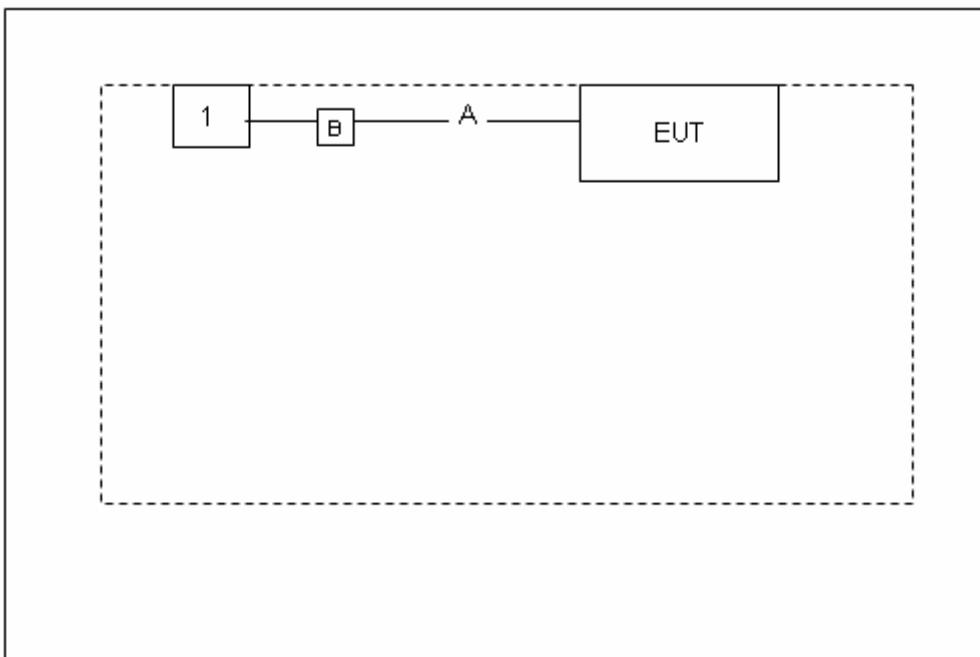

Signal Cable Type		Signal cable Description
A	USB Cable	Shielded, 0.7m
B	Ferrite Core	N/A



**1.5. EUT Exercise Software**

1	Setup the EUT and simulators as shown on above.
2	Turn on the power of equipment.
3	(1), Making EUT working on "GPS receive". (2), Making EUT connected to the computer, and then working in the super terminal

**2. Technical Test**

**2.1. Summary of Test Result**

- No deviations from the test standards
- Deviations from the test standards as below description:

Emission			
Performed Test Item	Normative References	Test Performed	Deviation
Conducted Emission	FCC CFR Title 47 Part 15 Subpart B: 2008 Class B ANSI C63.4: 2009	Yes	No
Radiated Emission	FCC CFR Title 47 Part 15 Subpart B: 2008 Class B ANSI C63.4: 2009	Yes	No

## 2.2. List of Test Equipment

### Conducted Emission / TR-1

Instrument	Manufacturer	Type No.	Serial No	Cali. Due Date
EMI Test Receiver	R&S	ESCI	100906	2012/01/15
Two-Line V-Network	R&S	ENV216	100043	2012/06/18
Two-Line V-Network	R&S	ENV216	100044	2011/09/07
Balanced Telecom ISN	Fischer	FCC-TLISN-T2-02	20352	2012/01/15
Balanced Telecom ISN	Fischer	FCC-TLISN-T4-02	20353	2012/01/15
Balanced Telecom ISN	Fischer	FCC-TLISN-T8-02	20354	2012/01/15
Current Probe	R&S	EZ-17	100255	2012/04/18
50ohm Coaxial Switch	Anritsu	MP59B	6200464462	2012/05/05
50ohm Termination	SHX	TF2	07081401	2011/09/27
50ohm Termination	SHX	TF2	07081402	2011/09/27
50ohm Termination	SHX	TF2	07081403	2011/09/15
Temperature/Humidity Meter	zhicheng	ZC1-2	TR1-TH	2012/01/14

### Radiated Emission / AC-2

Instrument	Manufacturer	Type No.	Serial No.	Cali. Due Date
EMI Test Receiver	R&S	ESCI	100573	2012/04/23
Bilog Antenna	Teseq GmbH	CBL6112D	27611	2011/10/18
Coaxial Cable	Huber+Suhner	SUCOFLEX 106	AC2-C	2012/05/05
Temperature/Humidity Meter	Zhicheng	ZC1-2	AC2-TH	2012/01/14

### Radiated Emission / AC-5

Instrument	Manufacturer	Type No.	Serial No.	Cali. Due Date
Spectrum Analyzer	Agilent	N9010A	MY48030494	2012/04/23
Preamplifier	Quietek	AP-180C	CHM-0602013	2012/05/05
Preamplifier	Quietek	AP-040G	CHM-0906001	2012/05/05
Bilog Antenna	Teseq GmbH	CBL6112D	27612	2011/10/18
Broad-Band Horn Antenna	Schwarzbeck	BBHA9120D	499	2012/06/11
High-Pass Filter	Wainwright	WHKX2.8/18G-12SS	SN1	2012/03/03
High-Pass Filter	Wainwright	WHKX7.0/18G-8SS	SN16	2012/03/03
Lowpass Filter	Wainwright	WLKS4500-9SS	SN2	2012/03/03

### **2.3. Measurement Uncertainty**

#### Conducted Emission

The measurement uncertainty is evaluated as  $\pm 2.26$  dB.

#### Radiated Emission

The measurement uncertainty is evaluated as  $\pm 3.19$  dB.

**2.4. Test Environment**

Performed Item	Items	Required	Actual
Conducted Emission	Temperature (°C)	15-35	25
	Humidity (%RH)	25-75	47
	Barometric pressure (mbar)	860-1060	950-1000
Radiated Emission	Temperature (°C)	15-35	28
	Humidity (%RH)	25-75	46
	Barometric pressure (mbar)	860-1060	950-1000

### 3. Conducted Emission

#### 3.1. Test Specification

According to EMC Standard: FCC Part 15 Subpart B Class B, ANSI C63.4

#### 3.2. Test Setup

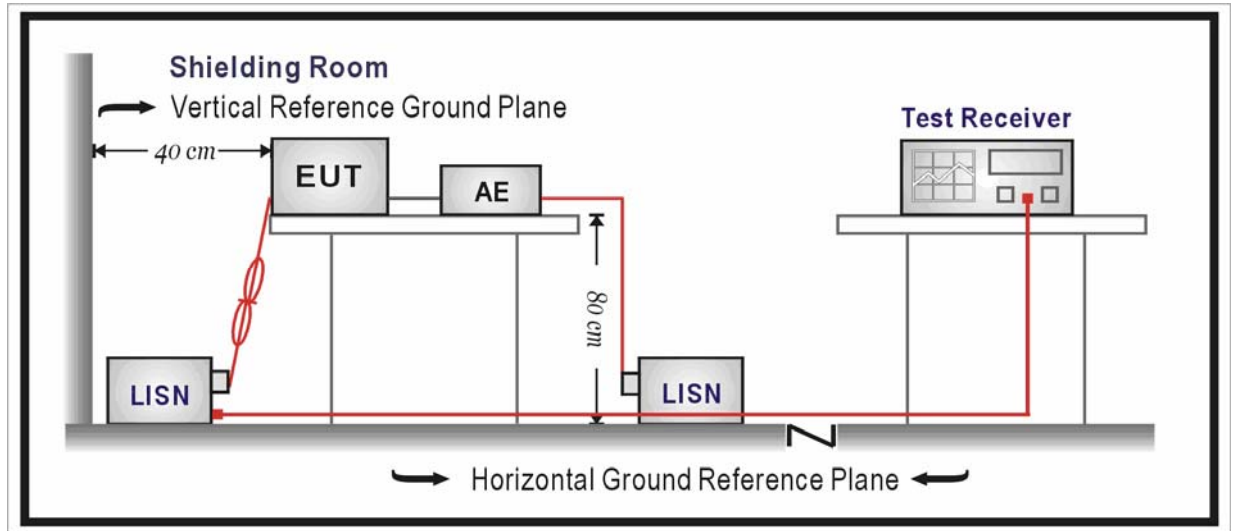

#### 3.3. Limit

FCC Part 15 Subpart B Paragraph 15.107 Limits		
Frequency (MHz)	QP (dBuV)	AV (dBuV)
0.15 - 0.50	66 - 56	56 - 46
0.50 - 5.0	56	46
5.0 - 30	60	50

Note 1: The lower limit shall apply at the transition frequencies.

Note 2: The limit decreases linearly with the logarithm of the frequency in the range 0.15 MHz to 0.5 MHz.

#### 3.4. Test Procedure

The EUT was placed on a platform of nominal size, 1 m by 1.5 m, raised 80 cm above the conducting ground plane. The vertical conducting plane was located 40 cm to the rear of the

EUT. All other surfaces of EUT were at least 80 cm from any other grounded conducting surface. The EUT and simulators are connected to the main power through a line impedance stabilization network (LISN). The LISN provides a 50 ohm /50uH coupling impedance for the measuring equipment. The peripheral devices are also connected to the main power through a LISN. (Please refer to the block diagram of the test setup and photographs)

Each current-carrying conductor of the EUT power cord, except the ground (safety) conductor, was individually connected through a LISN to the input power source.

The excess length of the power cord between the EUT and the LISN receptacle were folded back and forth at the center of the lead to form a bundle not exceeding 40 cm in length.

Conducted emissions were investigated over the frequency range from 0.15MHz to 30MHz using a receiver bandwidth of 9kHz.

### **3.5. Deviation from Test Standard**

No deviation.

### 3.6. Test Result

Engineer: Sunny	
Site: TR1	Time: 2011/06/16 - 14:58
Limit: FCC_Part15.107_CE_AC Power_ClassB	Margin: 0
Probe: ENV216_101044(0.009-30MHz)	Polarity: Line
EUT: GPS Tracker	Power: AC 120V/60Hz
Note: Mode 1	

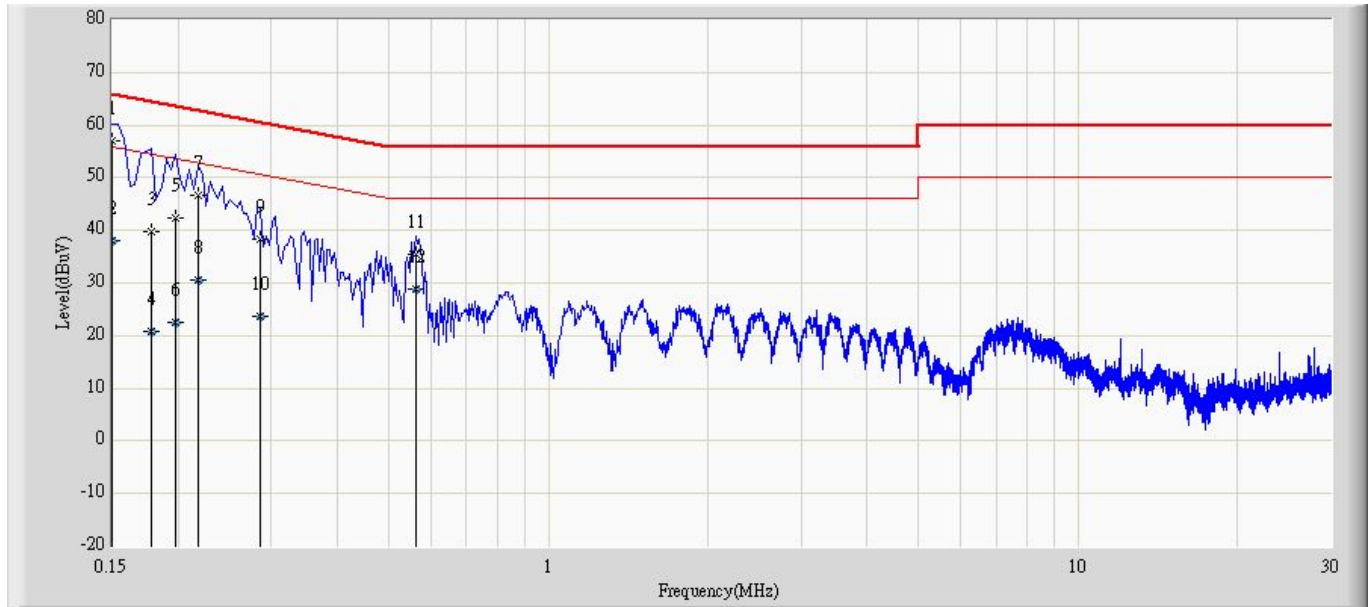

No	Mark	Frequency (MHz)	Measure Level (dBuV)	Reading Level (dBuV)	Over Limit (dB)	Limit (dBuV)	Factor (dB)	Type
1	*	0.150	56.983	47.303	-9.017	66.000	9.680	QP
2		0.150	38.151	28.471	-17.849	56.000	9.680	AV
3		0.178	39.809	30.142	-24.769	64.578	9.668	QP
4		0.178	20.689	11.022	-33.889	54.578	9.668	AV
5		0.198	42.258	32.602	-21.436	63.694	9.657	QP
6		0.198	22.402	12.745	-31.292	53.694	9.657	AV
7		0.218	46.739	37.088	-16.156	62.895	9.652	QP
8		0.218	30.542	20.891	-22.352	52.895	9.652	AV
9		0.286	38.413	28.757	-22.227	60.640	9.656	QP
10		0.286	23.629	13.973	-27.011	50.640	9.656	AV
11		0.562	35.447	25.774	-20.553	56.000	9.673	QP
12		0.562	28.846	19.172	-17.154	46.000	9.673	AV



Engineer: Sunny	
Site: TR1	Time: 2011/06/16 - 15:01
Limit: FCC_Part15.107_CE_AC Power_ClassB	Margin: 0
Probe: ENV216_101044(0.009-30MHz)	Polarity: Neutral
EUT: GPS Tracker	Power: AC 120V/60Hz
Note: Mode 1	

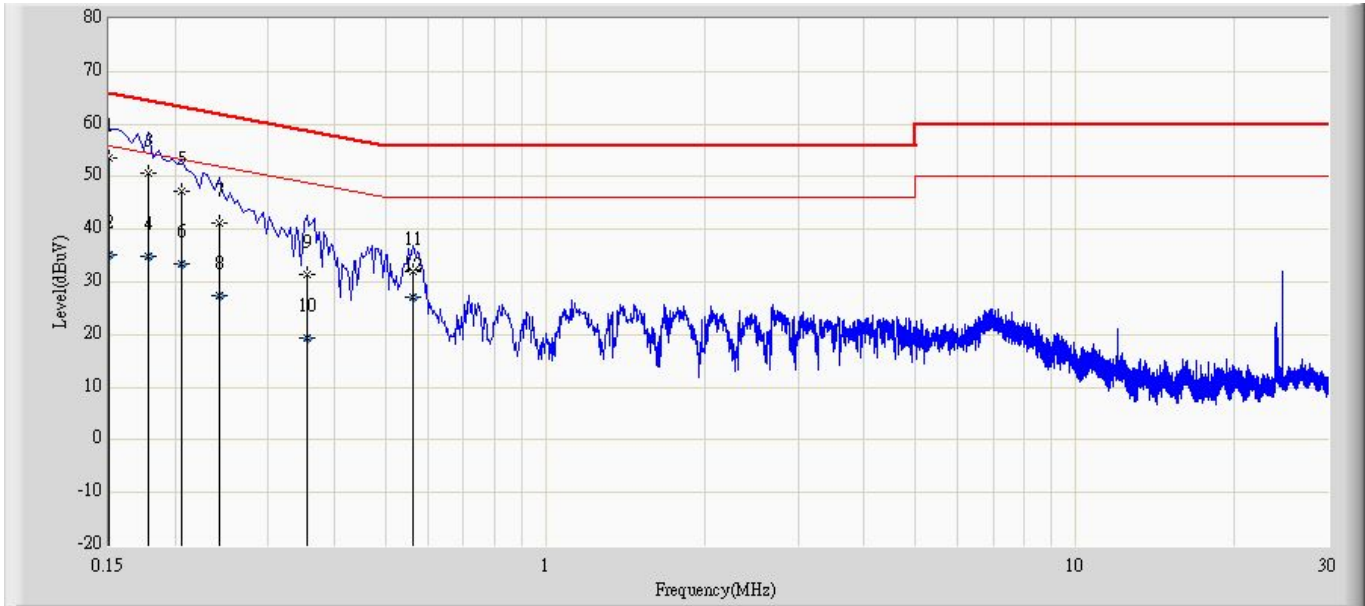

No	Mark	Frequency (MHz)	Measure Level (dBuV)	Reading Level (dBuV)	Over Limit (dB)	Limit (dBuV)	Factor (dB)	Type
1	*	0.150	53.645	44.035	-12.355	66.000	9.610	QP
2		0.150	35.032	25.422	-20.968	56.000	9.610	AV
3		0.178	50.573	40.920	-14.006	64.578	9.653	QP
4		0.178	34.768	25.115	-19.810	54.578	9.653	AV
5		0.206	47.325	37.628	-16.040	63.365	9.697	QP
6		0.206	33.424	23.727	-19.941	53.365	9.697	AV
7		0.242	41.102	31.395	-20.925	62.027	9.707	QP
8		0.242	27.557	17.849	-24.471	52.027	9.707	AV
9		0.354	31.522	21.822	-27.346	58.868	9.700	QP
10		0.354	19.437	9.738	-29.431	48.868	9.700	AV
11		0.562	32.037	22.347	-23.963	56.000	9.690	QP
12		0.562	27.030	17.340	-18.970	46.000	9.690	AV

Engineer: Jack	
Site: TR1	Time: 2011/06/21 - 19:45
Limit: FCC_Part15.107_CE_AC Power_ClassB	Margin: 0
Probe: ENV216_101044(0.009-30MHz)	Polarity: Line
EUT: GPS Tracker	Power: AC 120V/60Hz
Note: Mode 2	

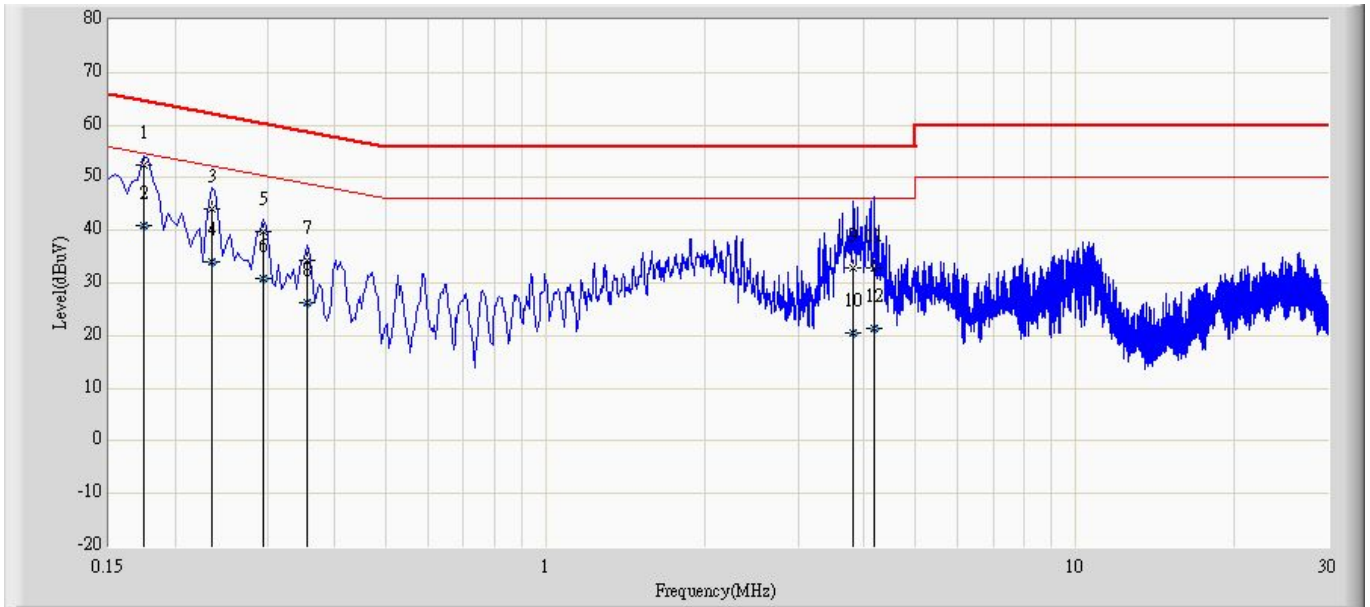

No	Mark	Frequency (MHz)	Measure Level (dBuV)	Reading Level (dBuV)	Over Limit (dB)	Limit (dBuV)	Factor (dB)	Type
1	*	0.174	52.285	42.614	-12.482	64.767	9.671	QP
2		0.174	40.955	31.284	-13.812	54.767	9.671	AV
3		0.234	44.039	34.387	-18.267	62.307	9.652	QP
4		0.234	34.107	24.455	-18.199	52.307	9.652	AV
5		0.294	39.858	30.202	-20.553	60.411	9.656	QP
6		0.294	30.816	21.160	-19.594	50.411	9.656	AV
7		0.354	34.181	24.521	-24.687	58.868	9.660	QP
8		0.354	26.361	16.700	-22.507	48.868	9.660	AV
9		3.818	32.930	23.220	-23.070	56.000	9.710	QP
10		3.818	20.411	10.701	-25.589	46.000	9.710	AV
11		4.170	32.895	23.179	-23.105	56.000	9.716	QP
12		4.170	21.506	11.790	-24.494	46.000	9.716	AV

Engineer: Jack	
Site: TR1	Time: 2011/06/21 - 20:02
Limit: FCC_Part15.107_CE_AC Power_ClassB	Margin: 0
Probe: ENV216_101044(0.009-30MHz)	Polarity: Neutral
EUT: GPS Tracker	Power: AC 120V/60Hz
Note: Mode 2	

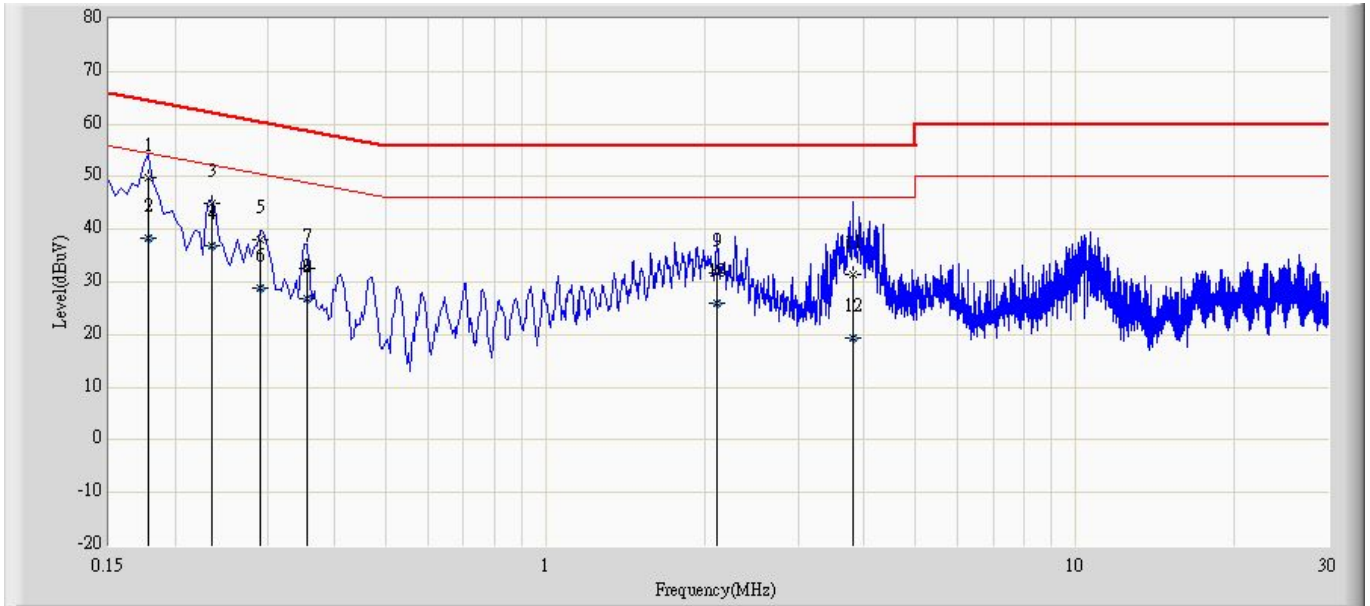

No	Mark	Frequency (MHz)	Measure Level (dBuV)	Reading Level (dBuV)	Over Limit (dB)	Limit (dBuV)	Factor (dB)	Type
1	*	0.178	49.846	40.193	-14.733	64.578	9.653	QP
2		0.178	38.431	28.778	-16.148	54.578	9.653	AV
3		0.234	45.029	35.321	-17.278	62.307	9.708	QP
4		0.234	36.971	27.263	-15.336	52.307	9.708	AV
5		0.290	37.923	28.220	-22.601	60.524	9.704	QP
6		0.290	28.744	19.041	-21.780	50.524	9.704	AV
7		0.354	32.559	22.859	-26.309	58.868	9.700	QP
8		0.354	26.928	17.228	-21.940	48.868	9.700	AV
9		2.110	31.695	22.003	-24.305	56.000	9.691	QP
10		2.110	25.948	16.257	-20.052	46.000	9.691	AV
11		3.810	31.466	21.751	-24.534	56.000	9.714	QP
12		3.810	19.466	9.752	-26.534	46.000	9.714	AV

### 3.7. Test Photograph

Description: Conducted emission Test Setup -Mode 1



Description: Conducted emission Test Setup-Mode 2

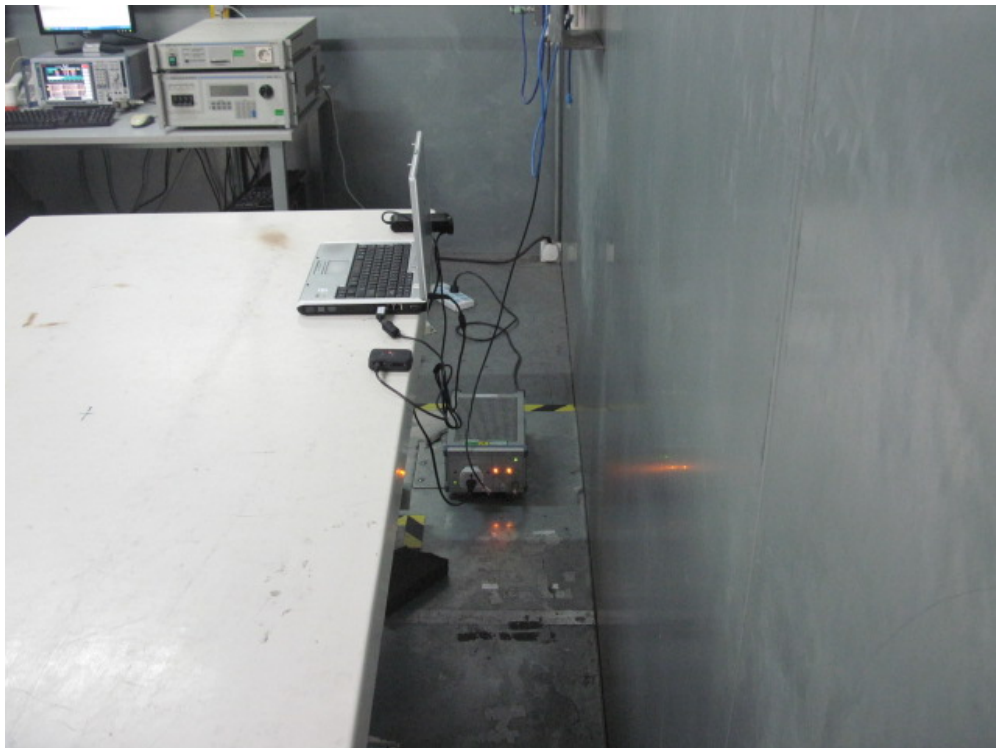

#### 4. Radiated Emission

##### 4.1. Test Specification

According to EMC Standard: FCC Part 15 Subpart B Class B, ANSI C63.4

##### 4.2. Test Setup

Below 1GHz Test Setup:

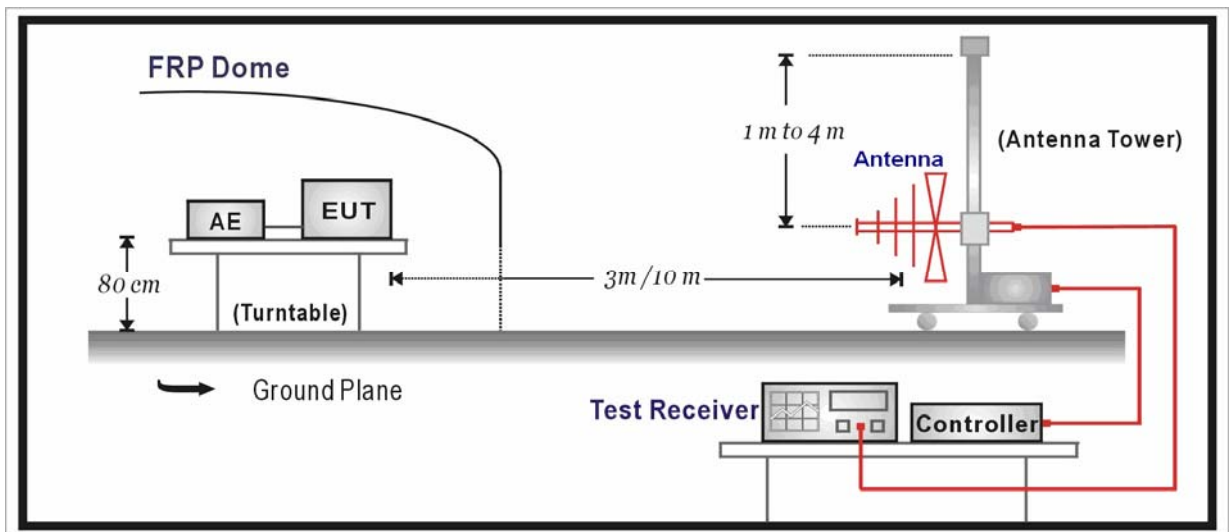

Above 1GHz Test Setup:

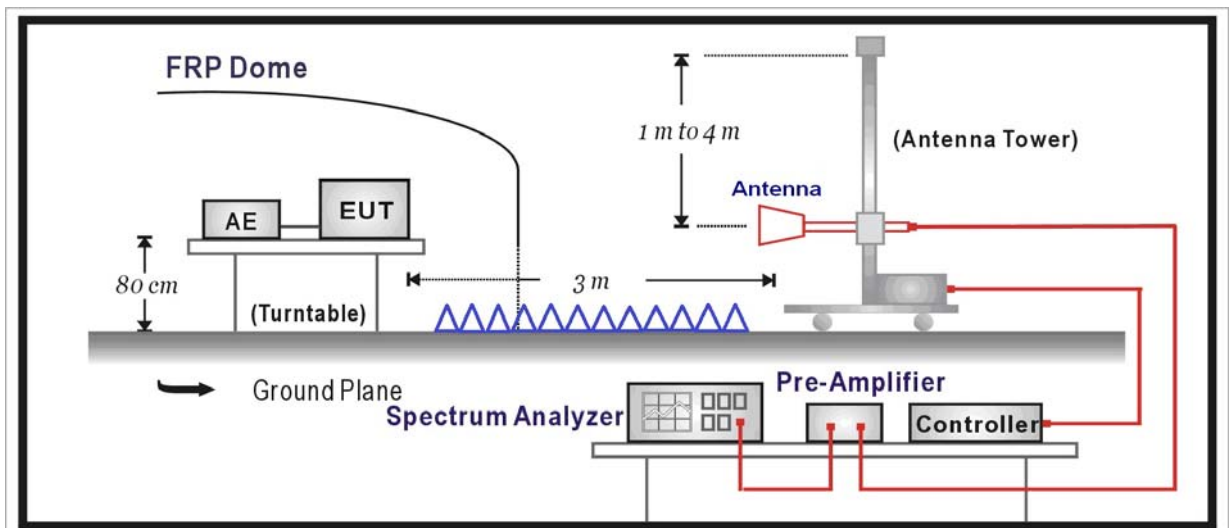

**4.3. Limit**

FCC Part 15 Subpart B Paragraph 15.109		
Frequency (MHz)	Distance (m)	Level (dBuV/m)
30 - 88	3	40
88 - 216	3	43.5
216 - 960	3	46
Above 960	3	54

Note 1: The lower limit shall apply at the transition frequency.

Note 2: Distance refers to the distance in meters between the measuring instrument antenna and the closed point of any part of the device or system.

Note 3: E field strength (dBuV/m) = 20 log E field strength (uV/m)

**4.4. Test Procedure**

The EUT and its simulators are placed on a turn table which is 0.8 meter above ground. The turn table can rotate 360 degrees to determine the position of the maximum emission level. The EUT was positioned such that the distance from antenna to the EUT was 3 meters. The antenna can move up and down between 1 meter and 4 meters to find out the maximum emission level.

Both horizontal and vertical polarization of the antenna are set on measurement. In order to find the maximum emission, all of the interface cables must be manipulated on radiated measurement.

For an unintentional radiator, including a digital device, the spectrum shall be investigated from the lowest radio frequency signal generated or used in the device, without going below the lowest frequency for which a radiated emission limit is specified, up to the frequency shown in the following table:

Highest frequency generated or used in the device or on which the device operates or tunes (MHz)	Upper frequency of measurement range (MHz)
Below 1.705	30
1.705 - 108	1000
108 - 500	2000

500 - 1000	5000
Above 1000	5th harmonic of the highest frequency or 40 GHz, whichever is lower

On any frequency or frequencies below or equal to 1000 MHz, the radiated limits shown are based on measuring equipment employing a quasi-peak detector function and above 1000 MHz, the radiated limits shown are based measuring equipment employing an average detector function.

When average radiated emission measurement are included emission measurement Above 1000 MHz, there also is a limit on the radio frequency emissions, as measured using instrumentation with a peak detector function, corresponding to 20 dB above the maximum permitted average limit.

For class A, the measurement distance between the EUT and antenna is 3 meters for under 1GHz and above 1GHz.

For class B, the measurement distance between the EUT and antenna is 3 meters for under 1GHz and 3 meters for above 1GHz.

The bandwidth below 1GHz setting on the field strength meter (R&S Test Receiver ESCI) is 120 kHz and above 1GHz is 1MHz.

Note: When measurement above 1GHz, the horn antenna will bend down a little (as horn antenna have the narrow beamwidth) in order to find the maximum emission of EUT.

**4.5. Deviation from Test Standard**

No deviation.

## 4.6. Test Result

Engineer: Jack	
Site: AC2	Time: 2011/06/21 - 09:16
Limit: FCC_Part15.109_RE(3m)_ClassB	Margin: 0
Probe: CBL6112D_27611(30-1000MHz)	Polarity: Horizontal
EUT: GPS Tracker	Power: AC 120V/60Hz
Note: Mode 1	

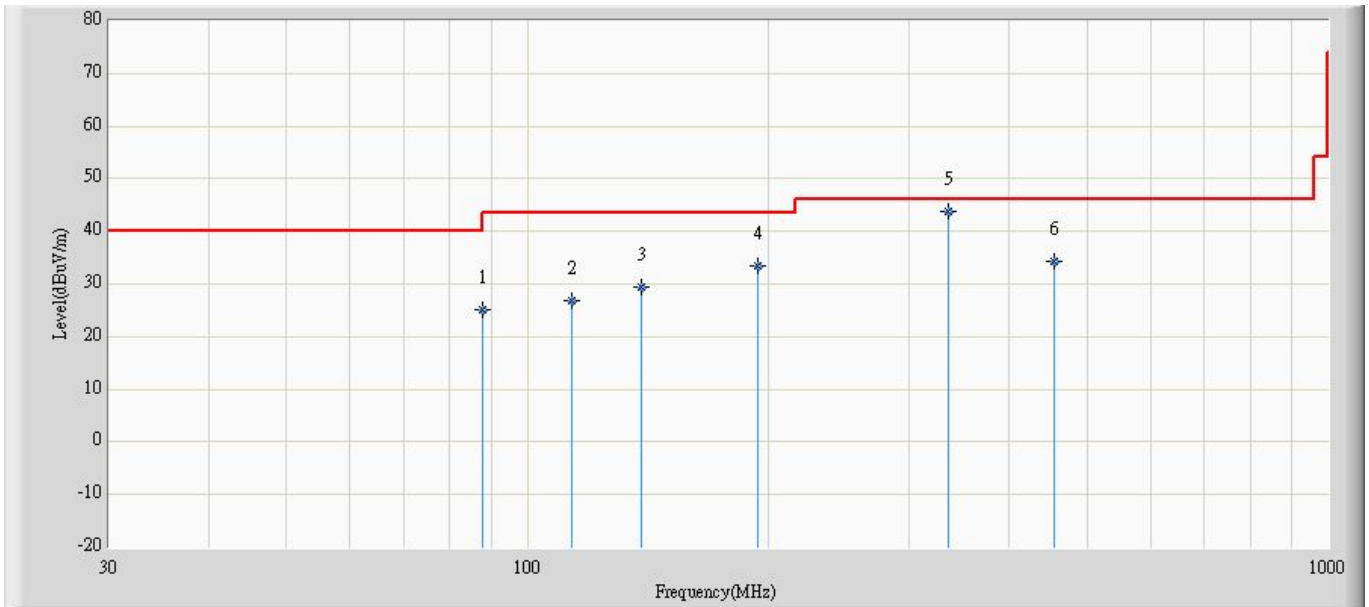

No	Flag	Mark	Frequency (MHz)	Measure Level (dBuV/m)	Reading Level (dBuV)	Over Limit (dB)	Limit (dBuV/m)	Factor	Type
1			87.957	25.170	16.106	-14.830	40.000	9.064	QP
2			113.784	26.719	14.293	-16.781	43.500	12.426	QP
3			138.761	29.371	17.312	-14.129	43.500	12.059	QP
4			194.173	33.579	23.336	-9.921	43.500	10.243	QP
5		*	335.920	43.723	28.001	-2.277	46.000	15.722	QP
6			455.951	34.412	15.992	-11.588	46.000	18.420	QP



Engineer: Jack	
Site: AC2	Time: 2011/06/21 - 09:16
Limit: FCC_Part15.109_RE(3m)_ClassB	Margin: 0
Probe: CBL6112D_27611(30-1000MHz)	Polarity: Vertical
EUT: GPS Tracker	Power: AC 120V/60Hz
Note: Mode 1	

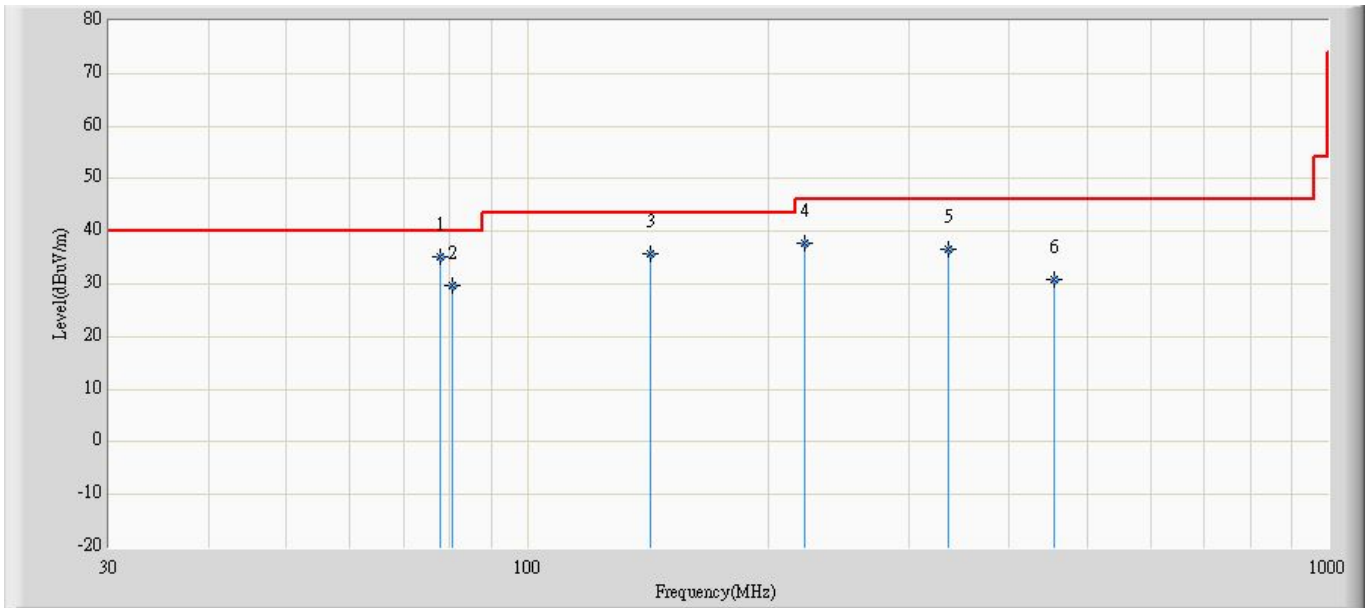

No	Flag	Mark	Frequency (MHz)	Measure Level (dBuV/m)	Reading Level (dBuV)	Over Limit (dB)	Limit (dBuV/m)	Factor	Type
1		*	77.876	35.174	28.071	-4.826	40.000	7.103	QP
2			80.594	29.710	22.201	-10.290	40.000	7.509	QP
3			142.156	35.755	24.032	-7.745	43.500	11.723	QP
4			221.939	37.743	27.630	-8.257	46.000	10.113	QP
5			335.914	36.699	20.978	-9.301	46.000	15.722	QP
6			455.830	30.982	12.564	-15.018	46.000	18.418	QP

Engineer: Jack	
Site: AC2	Time: 2011/06/22 - 12:01
Limit: FCC_Part15.109_RE(3m)_ClassB	Margin: 0
Probe: CBL6112D_27611(30-1000MHz)	Polarity: Horizontal
EUT: GPS Tracker	Power: AC 120V/60Hz
Note: Mode 2	

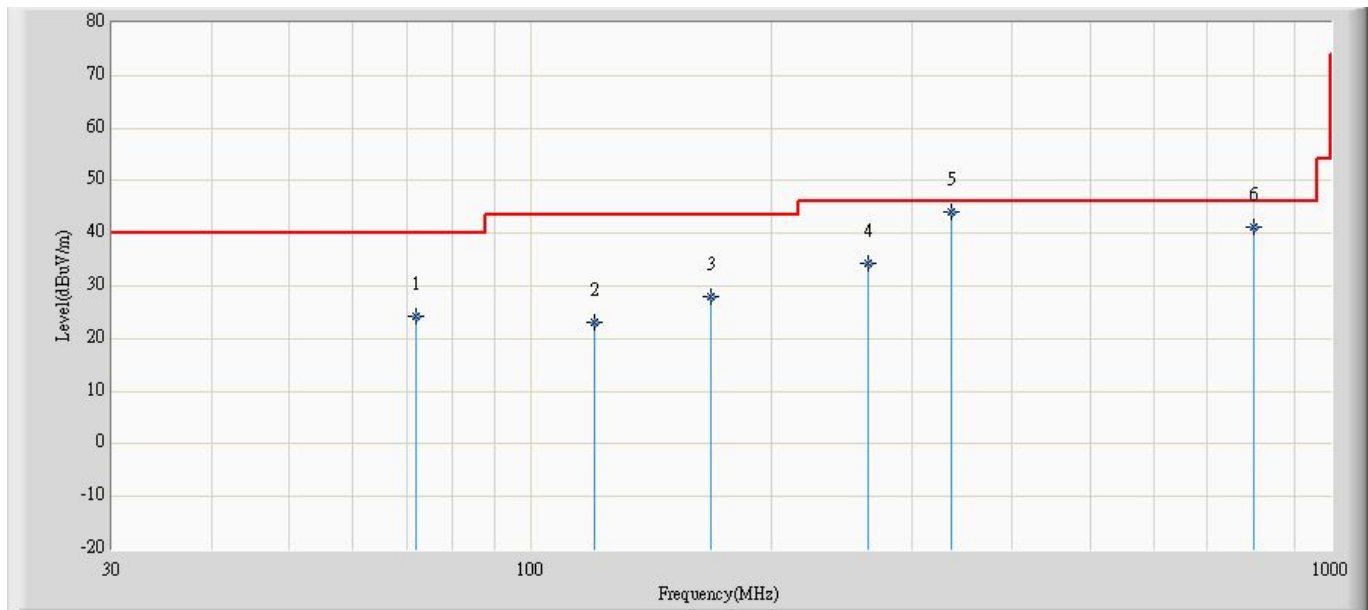

No	Flag	Mark	Frequency (MHz)	Measure Level (dBuV/m)	Reading Level (dBuV)	Over Limit (dB)	Limit (dBuV/m)	Factor	Type
1			71.952	24.264	18.112	-15.736	40.000	6.152	QP
2			119.967	23.211	10.486	-20.289	43.500	12.725	QP
3			167.982	27.848	17.465	-15.652	43.500	10.383	QP
4			263.891	34.334	20.243	-11.666	46.000	14.091	QP
5		*	335.899	44.137	28.500	-1.863	46.000	15.637	QP
6			800.059	41.241	18.702	-4.759	46.000	22.539	QP

Engineer: Jack	
Site: AC2	Time: 2011/06/22 - 12:01
Limit: FCC_Part15.109_RE(3m)_ClassB	Margin: 0
Probe: CBL6112D_27611(30-1000MHz)	Polarity: Vertical
EUT: GPS Tracker	Power: AC 120V/60Hz
Note: Mode 2	

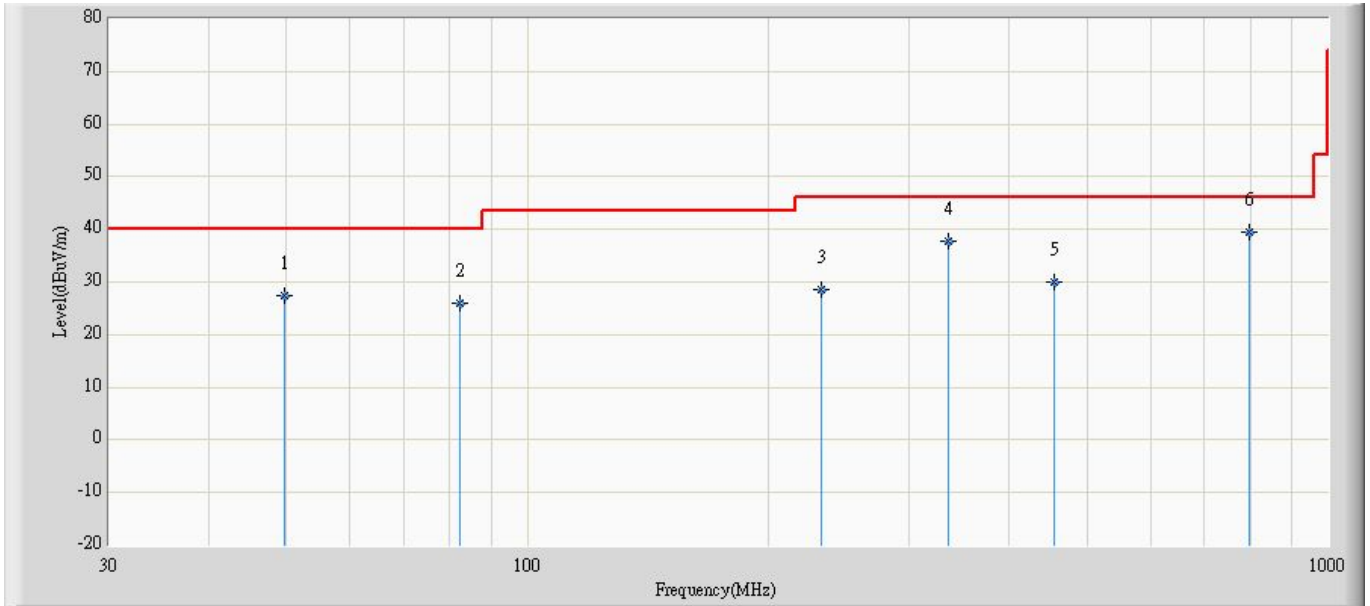

No	Flag	Mark	Frequency (MHz)	Measure Level (dBuV/m)	Reading Level (dBuV)	Over Limit (dB)	Limit (dBuV/m)	Factor	Type
1			49.764	27.386	19.084	-12.614	40.000	8.303	QP
2			82.137	25.983	18.041	-14.017	40.000	7.942	QP
3			232.851	28.684	17.317	-17.316	46.000	11.367	QP
4			335.914	37.746	22.108	-8.254	46.000	15.637	QP
5			455.830	29.879	11.459	-16.121	46.000	18.420	QP
6		*	797.997	39.538	17.018	-6.462	46.000	22.520	QP

Engineer: Jack	
Site: AC5	Time: 2011/06/21 - 09:27
Limit: FCC_Part15.109_RE(3m)_ClassB	Margin: 0
Probe: BBHA9120D_499(1-18GHz)	Polarity: Horizontal
EUT: GPS Tracker	Power: AC 120V/60Hz
Note: Mode 1	

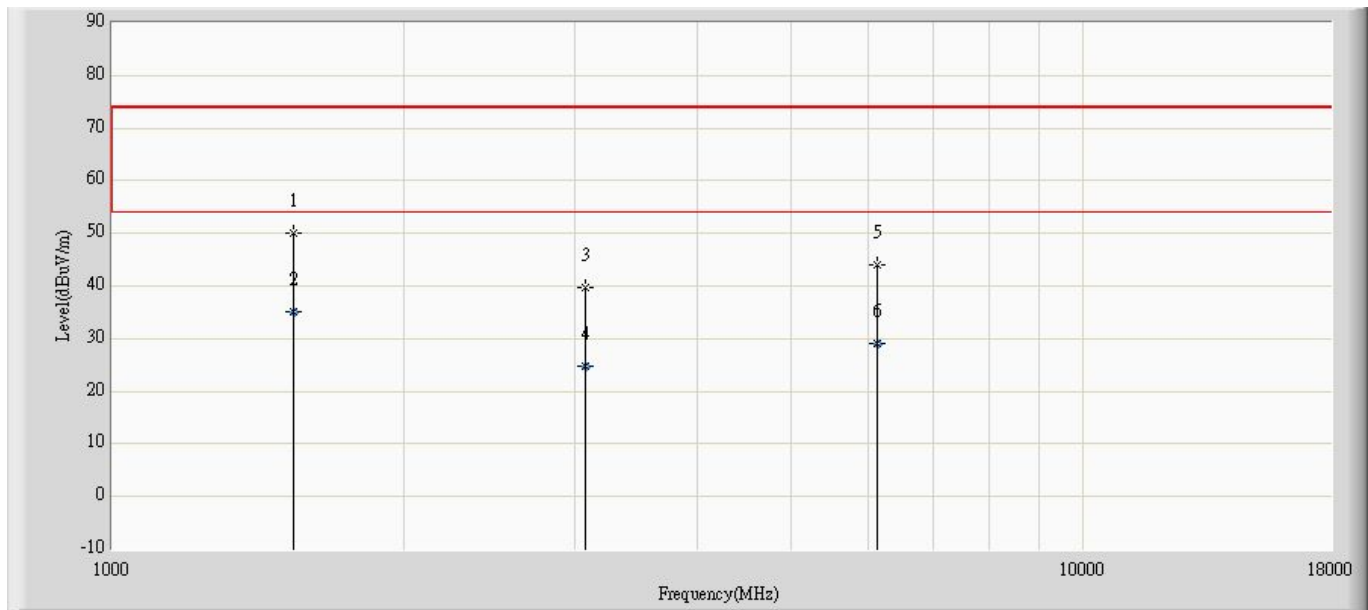

No	Flag	Mark	Frequency (MHz)	Measure Level (dBuV/m)	Reading Level (dBuV)	Over Limit (dB)	Limit (dBuV/m)	Factor	Type
1			1535.500	50.019	70.999	-23.981	74.000	-20.980	PK
2		*	1535.500	35.173	56.153	-18.827	54.000	-20.980	AV
3			3074.000	39.762	55.608	-34.238	74.000	-15.846	PK
4			3074.000	24.685	40.531	-29.315	54.000	-15.846	AV
5			6142.500	43.951	52.980	-30.049	74.000	-9.030	PK
6			6142.500	29.001	38.031	-24.999	54.000	-9.030	AV

Engineer: Jack	
Site: AC5	Time: 2011/06/21 - 09:27
Limit: FCC_Part15.109_RE(3m)_ClassB	Margin: 0
Probe: BBHA9120D_499(1-18GHz)	Polarity: Vertical
EUT: GPS Tracker	Power: AC 120V/60Hz
Note: Mode 1	

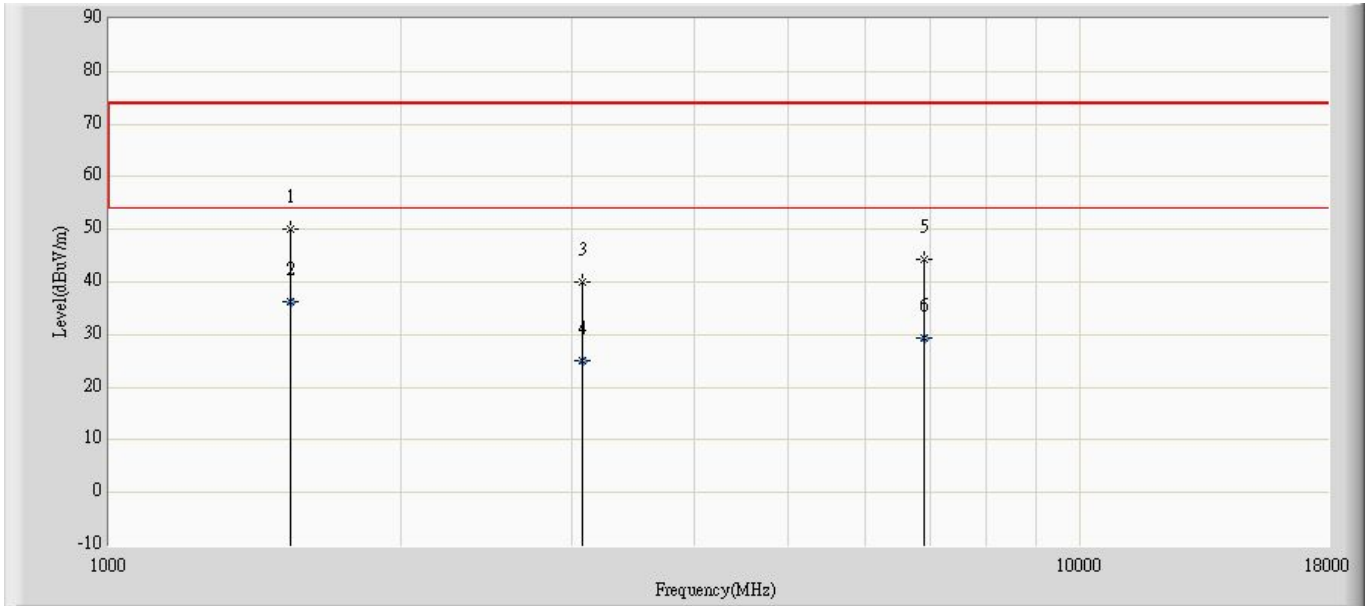

No	Flag	Mark	Frequency (MHz)	Measure Level (dBuV/m)	Reading Level (dBuV)	Over Limit (dB)	Limit (dBuV/m)	Factor	Type
1			1535.500	50.039	71.019	-23.961	74.000	-20.980	PK
2		*	1535.500	36.163	57.143	-17.837	54.000	-20.980	AV
3			3074.000	40.128	55.974	-33.872	74.000	-15.846	PK
4			3074.000	25.143	40.989	-28.857	54.000	-15.846	AV
5			6899.000	44.281	50.184	-29.719	74.000	-5.903	PK
6			6899.000	29.428	35.331	-24.572	54.000	-5.903	AV

Engineer: Jack	
Site: AC5	Time: 2011/06/22 - 13:02
Limit: FCC_Part15.109_RE(3m)_ClassB	Margin: 0
Probe: BBHA9120D_499(1-18GHz)	Polarity: Horizontal
EUT: GPS Tracker	Power: AC 120V/60Hz
Note: Mode 2	

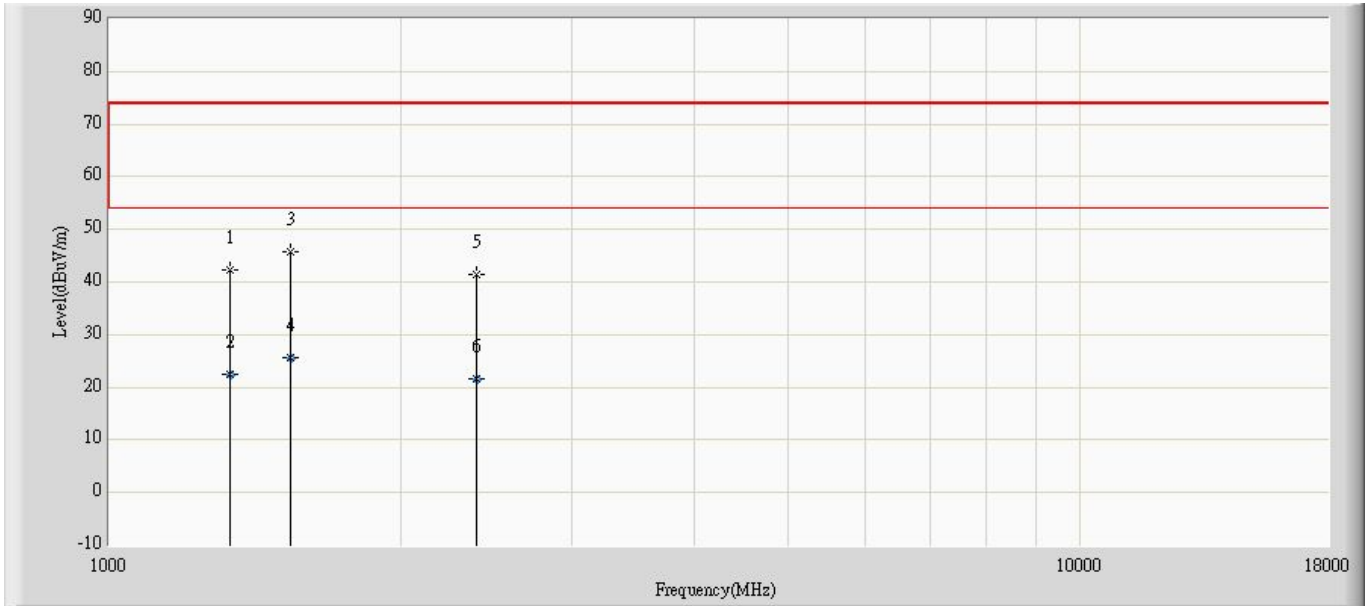

No	Flag	Mark	Frequency (MHz)	Measure Level (dBuV/m)	Reading Level (dBuV)	Over Limit (dB)	Limit (dBuV/m)	Factor	Type
1			1331.500	42.439	63.553	-31.561	74.000	-21.113	PK
2			1331.500	22.549	43.663	-31.451	54.000	-21.113	AV
3			1535.500	45.714	66.693	-28.286	74.000	-20.980	PK
4		*	1535.500	25.733	46.713	-28.267	54.000	-20.980	AV
5			2394.000	41.556	58.796	-32.444	74.000	-17.240	PK
6			2394.000	21.541	38.781	-32.459	54.000	-17.240	AV

Engineer: Jack	
Site: AC5	Time: 2011/06/22 - 13:01
Limit: FCC_Part15.109_RE(3m)_ClassB	Margin: 0
Probe: BBHA9120D_499(1-18GHz)	Polarity: Vertical
EUT: GPS Tracker	Power: AC 120V/60Hz
Note: Mode 2	

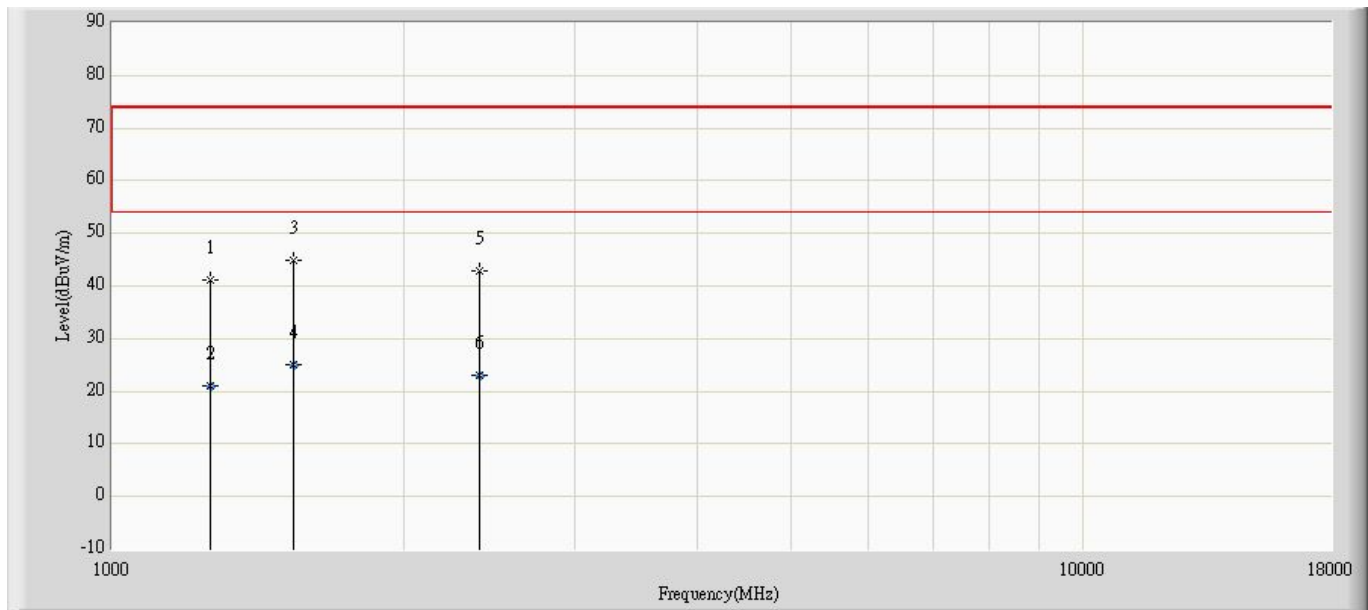

No	Flag	Mark	Frequency (MHz)	Measure Level (dBuV/m)	Reading Level (dBuV)	Over Limit (dB)	Limit (dBuV/m)	Factor	Type
1			1263.500	41.236	62.736	-32.764	74.000	-21.500	PK
2			1263.500	21.094	42.593	-32.906	54.000	-21.500	AV
3			1535.500	45.001	65.980	-28.999	74.000	-20.980	PK
4		*	1535.500	25.012	45.991	-28.988	54.000	-20.980	AV
5			2394.000	42.951	60.191	-31.049	74.000	-17.240	PK
6			2394.000	23.003	40.243	-30.997	54.000	-17.240	AV

**4.7. Test Photograph**

Description: Radiated Emission Test Setup for Below 1GHz-Mode 1

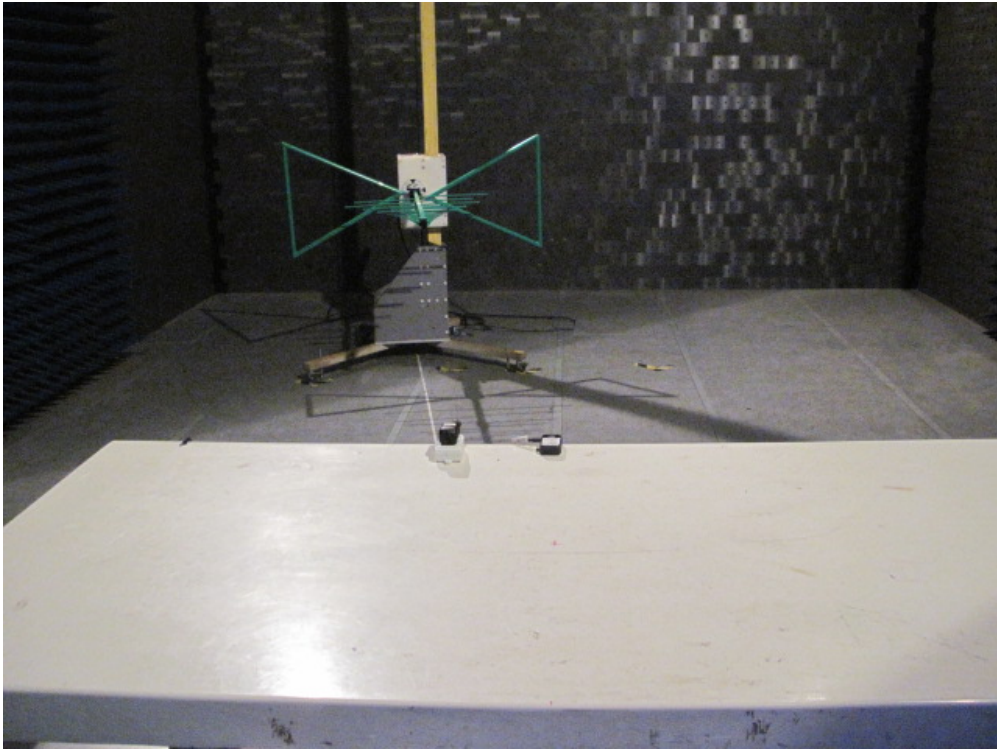

Description: Radiated Emission Test Setup for Below 1GHz-Mode 2

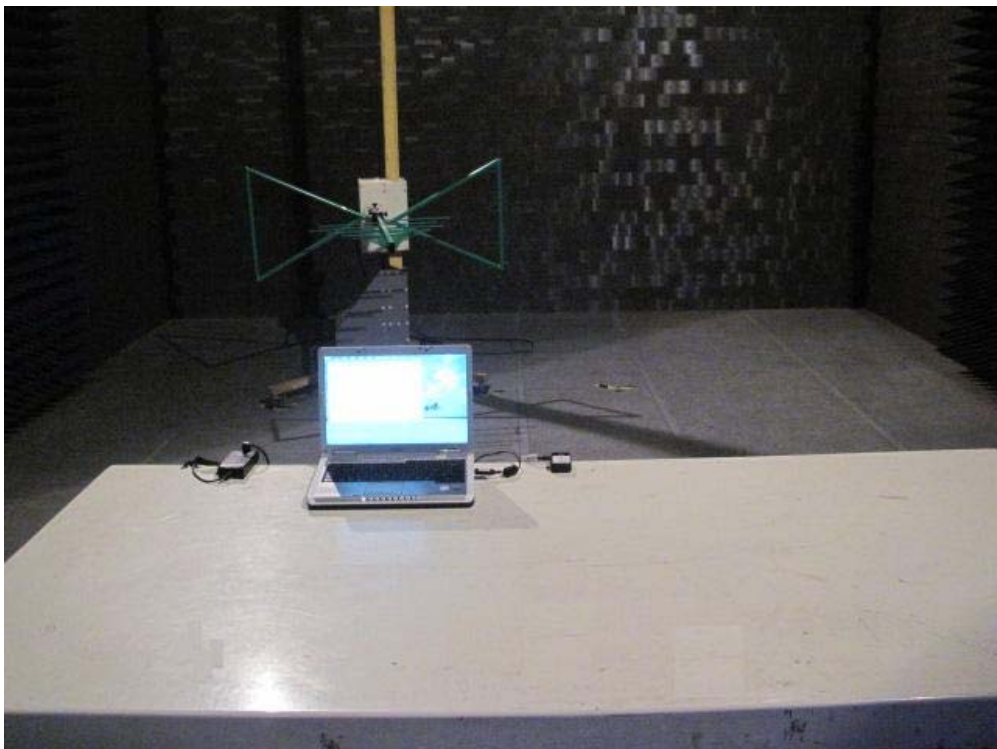



Description: Radiated Emission Test Setup for Above 1GHz-Mode 1



Description: Radiated Emission Test Setup for Above 1GHz-Mode 2

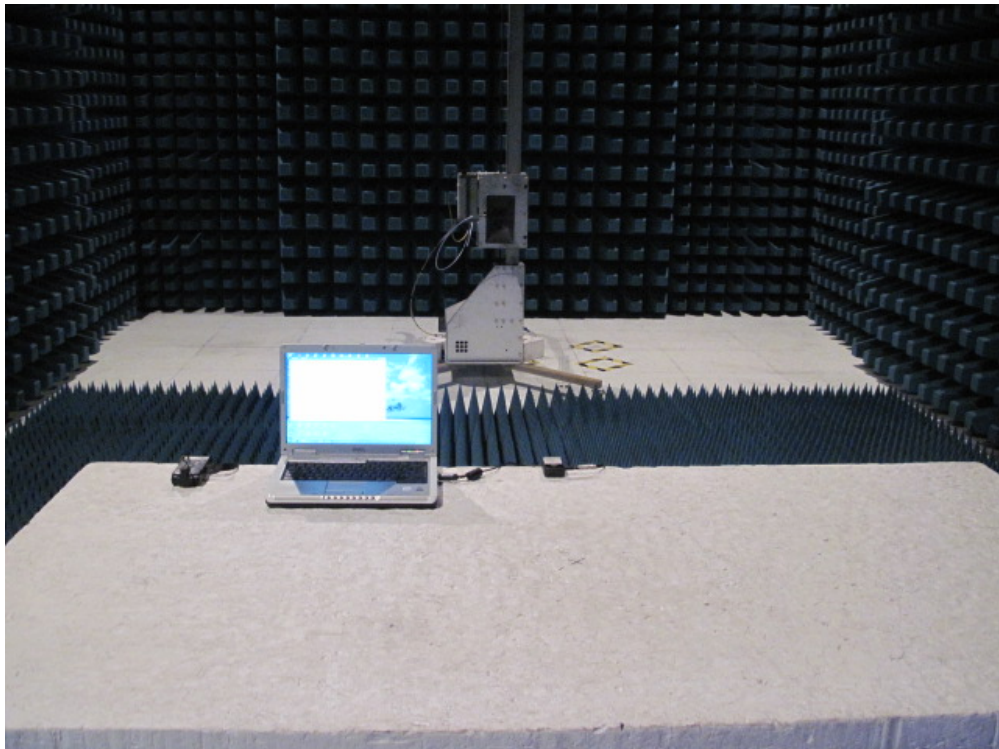

## 5. Attachment

### ➤ EUT Photograph

(1) EUT Photo



(2) EUT Photo



(3) EUT Photo



(4) EUT Photo



(5) EUT Photo



(6) EUT Photo



(7) EUT Photo



(8) EUT Photo

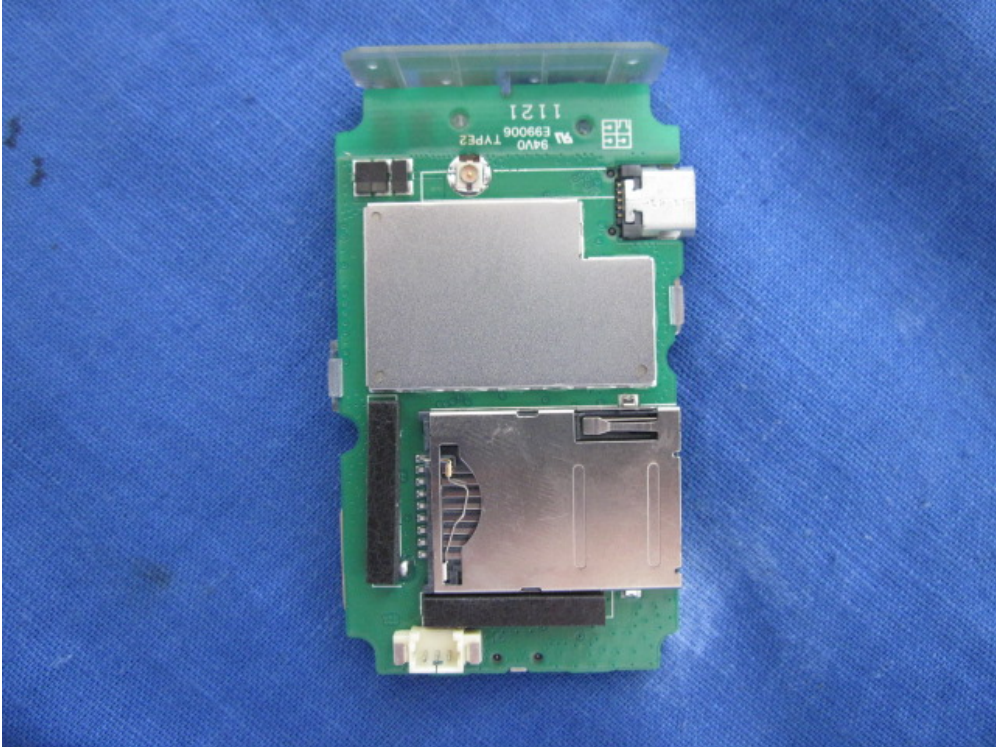

(9) EUT Photo



(10) EUT Photo



(11) EUT Photo



(12) EUT Photo



(13) EUT Photo

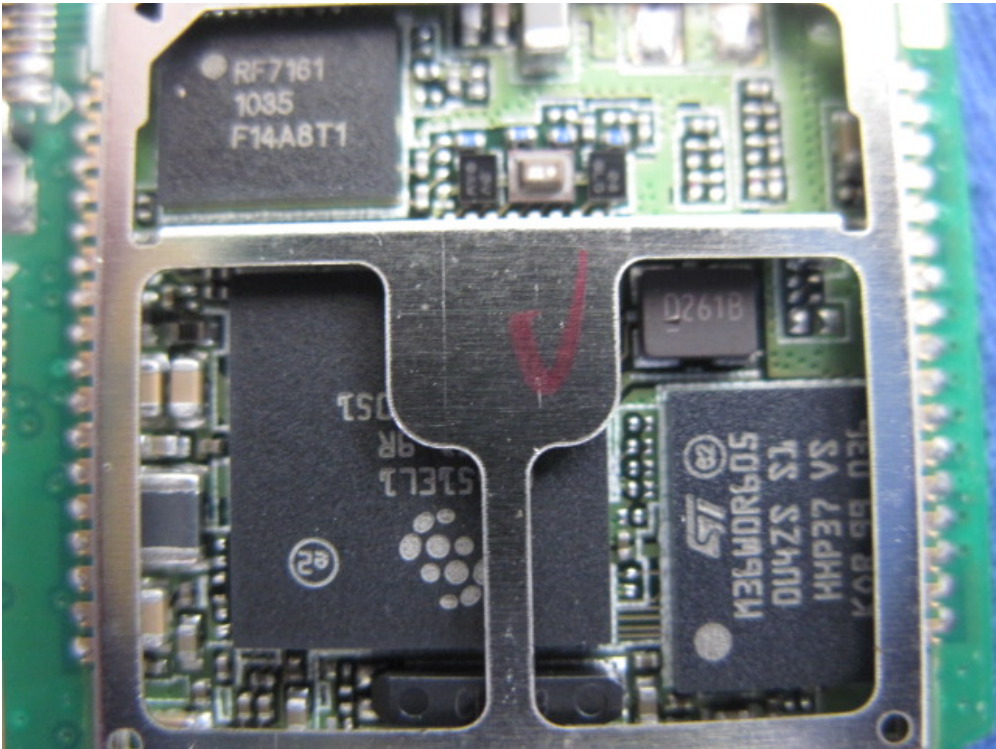

(14) EUT Photo

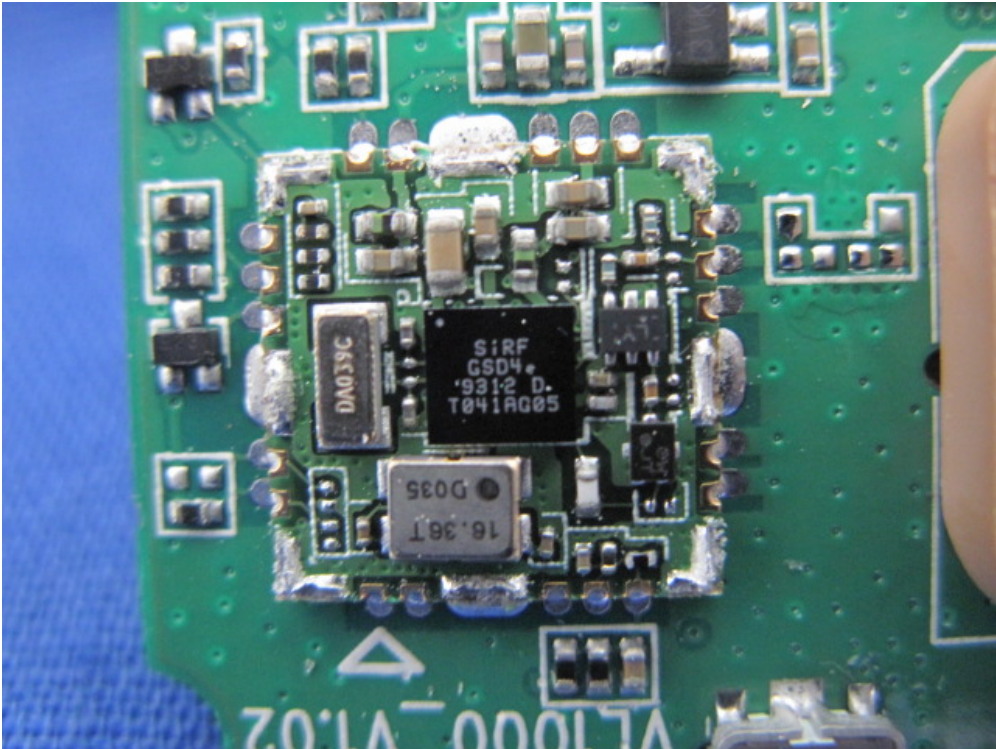



(15) EUT Photo

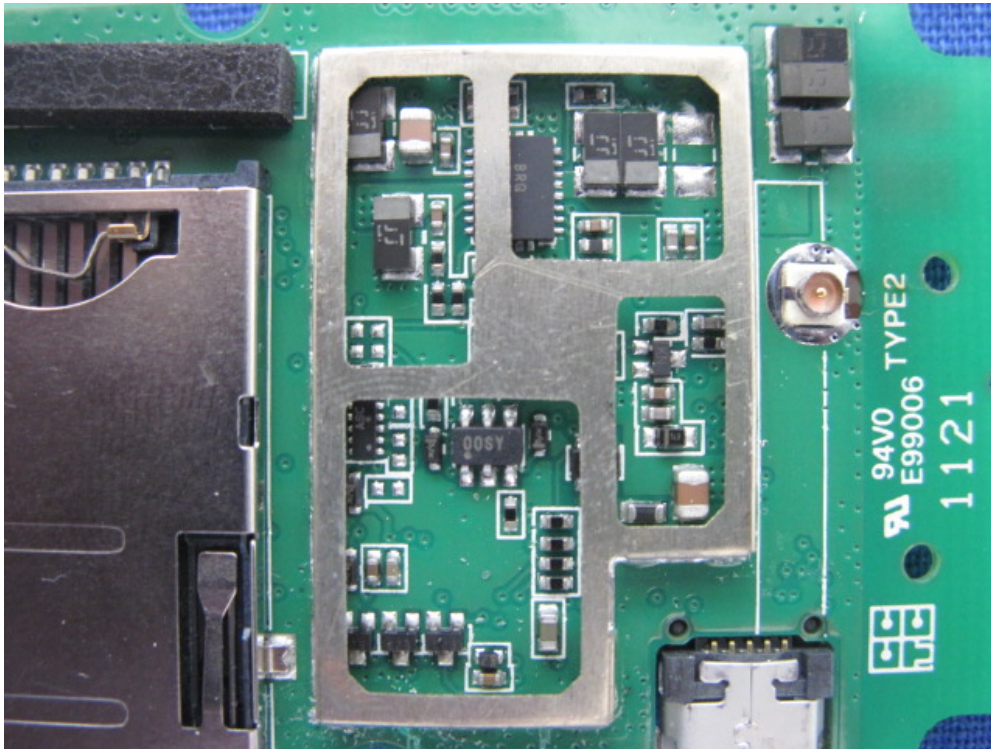

(16) EUT Photo



(17) EUT Photo



(18) EUT Photo



(19) EUT Photo



(20) EUT Photo

