FCC Test Report

Report No.: AGC035110401F2

FCC ID : ZJVMT-5000
PRODUCT DESIGNATION : Bluetooth Headset
BRAND NAME : N/A
TEST MODEL : MT-5000
CLIENT : Premier Accessory Group
DATE OF ISSUE : May.11, 2011
STANDARD(S) : FCC Part 15 Rules

Attestation of *Global Compliance Co., Ltd.*

CAUTION: This report shall not be reproduced except in full without the written permission of the test laboratory and shall not be quoted out of context.

VERIFICATION OF COMPLIANCE

Applicant	Premier Accessory Group
	11-11 44 th Drive, Long Island City, NY 11101, USA
Manufacturer	Deno Industrial (HK) Co., Ltd
	Floor 3, Building C, Feng Men Ao Industrial Park, GangTou, BanTian, Longgang Disrict, Shenzhen, China.
Product Designation	Bluetooth Headset
Brand Name	N/A
Model Name	MT-5000
FCC ID	ZJVMT-5000
Report Number	AGC035110401F2
Date of Test	May.10, 2011 to May.11, 2011

WE HEREBY CERTIFY THAT:

The above equipment was tested by Attestation of Global Compliance Co., Ltd. The test data, data evaluation, test procedures, and equipment configurations shown in this report were made in accordance with the procedures given in ANSI C63.4 (2003) and the energy emitted by the sample EUT tested as described in this report is in compliance with radiated emission limits of FCC Rules Part 15.247.

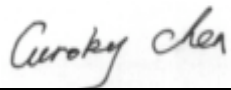
Checked By: 
Curoky Chen May.11, 2011

Authorized By 
Forrest Lei May.11, 2011

TABLE OF CONTENTS

1 GENERAL INFORMATION	4
1.1 PRODUCT DESCRIPTION	4
1.2 TABLE OF CARRIER FREQUENCYS	4
1.3 RECEIVER INPUT BANDWIDTH	4
1.4 EXAMPLE OF A HOPPING SEQUENCY IN DATA MODE	5
1.5 EQUALLY AVERAGE USE OF FREQUENCIES AND BEHAVIOUR	5
1.6 RELATED SUBMITTAL(S) / GRANT (S)	5
1.7 TEST METHODOLOGY	5
1.8 TEST FACILITY	6
1.9 SPECIAL ACCESSORIES	6
1.10 EQUIPMENT MODIFICATIONS	6
2 SYSTEM TEST CONFIGURATION	7
2.1 CONFIGURATION OF TESTED SYSTEM	7
2.2 EQUIPMENT USED IN TESTED SYSTEM	7
3 SUMMARY OF TEST RESULTS.....	8
4. DESCRIPTION OF TEST MODES.....	8
5 PEAK OUTPUT POWER	9
5.1 MEASUREMENT PROCEDURE	9
5.2 TEST SET-UP (BLOCK DIAGRAM OF CONFIGURATION)	9
5.3 MEASUREMENT EQUIPMENT USED	10
5.4 LIMITS AND MEASUREMENT RESULT	10
6 20 DB BANDWIDTH.....	11
6.1 MEASUREMENT PROCEDURE	11
6.2 TEST SET-UP (BLOCK DIAGRAM OF CONFIGURATION)	11
6.3 MEASUREMENT EQUIPMENT USED	11
6.4 LIMITS AND MEASUREMENT RESULTS	11
7. MAXIMUM CONDUCTED OUTPUT POWER SPECTRAL DENSITY	14
8. CONDUCTED SPURIOUS EMISSION.....	15
8.1 MEASUREMENT PROCEDURE	15
8.2 TEST SET-UP (BLOCK DIAGRAM OF CONFIGURATION)	15
8.3 MEASUREMENT EQUIPMENT USED	15
8.4 LIMITS AND MEASUREMENT RESULT	15
9. RADIATED EMISSION FOR RESTRICTED BAND.....	17
10 BAND EDGES EMISSION	24
10.1 MEASUREMENT PROCEDURE	24
10.2 TEST SET-UP	24
10.3 TEST RESULT	24
11 NUMBER OF HOPPING FREQUENCY	28
11.1 MEASUREMENT PROCEDURE	28
11.2 TEST SETUP (BLOCK DIAGRAM OF CONFIGURATION)	28
11.3 MEASUREMENT EQUIPMENT USED	28
11.4 LIMITS AND MEASUREMENT RESULT	28
12 TIME OF OCCUPANCY (DWELL TIME)	29
12.1 MEASUREMENT PROCEDURE	29

12.2 TEST SETUP (BLOCK DIAGRAM OF CONFIGURATION).....	29
12.3 MEASUREMENT EQUIPMENT USED.....	29
12.4 LIMITS AND MEASUREMENT RESULT.....	29
13. FREQUENCY SEPARATION	32
13.1 MEASUREMENT PROCEDURE	32
13.2 TEST SETUP (BLOCK DIAGRAM OF CONFIGURATION).....	32
13.3 MEASUREMENT EQUIPMENT USED.....	32
13.4 LIMITS AND MEASUREMENT RESULT.....	32
14 FCC LINE CONDUCTED EMISSION TEST.....	33
APPENDIX I.....	34
PHOTOGRAPHS OF THE EUT	34
APPENDIX II.....	37
PHOTOGRAPHS OF THE TEST SETUP	37

1 GENERAL INFORMATION

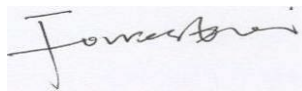
1.1 PRODUCT DESCRIPTION

The EUT is a **Bluetooth Headset** designed as an “Communication Device”. It is designed by way of utilizing the FHSS technology to achieve the system operation.

A major technical description of EUT is described as following

Operation Frequency	2.402 GHz to 2.480GHz
Rated Output Power	3.88 dBm (max)
Modulation	GFSK, $\pi/4$ -DQPSK, 8-DPSK
Number of channels	79
Antenna Designation	Integrated Antenna
Antenna Gain	0.8dBi
Power Supply	DC3.7V by Built-in Li-ion Battery(or charging through USB port of PC or external adapter)
<i>**note: The Bluetooth function of the device shall deactivated automatically while charging For the End product communicate through USB port is not supported</i>	

1.2 TABLE OF CARRIER FREQUENCIES

Frequency Band	Channel Number	Frequency
2400~2483.5MHZ	0	2402MHZ
	1	2403MHZ
	:	:
	38	2440 MHZ
	39	2441 MHZ
	40	2442 MHZ
	:	:
	77	2479 MHZ
	78	2480 MHZ

1.3 RECEIVER INPUT BANDWIDTH

The input bandwidth of the receiver is 1MHZ, In every connection one Bluetooth device is the master and the other one is slave. The master determines the hopping sequence. The slave follows this sequence. Both devices shift between RX and TX time slot according to the clock of the master. Additionally the type of connection(e.g. single of multislotted packet) is set up at the beginning of the connection. The master adapts its hopping frequency and its TX/RX timing according to the packet type of the connection. Also the slave of the connection will use these settings.

Repeating of a packet has no influence on the hopping sequence. The hopping sequence generated by the master of the connection will be followed in any case. That means, a repeated packet will not be send on the same frequency, it is send on the next frequency of the hopping sequence.

1.4 EXAMPLE OF A HOPPING SEQUENCY IN DATA MODE

Example of a 79 hopping sequence in data mode:
40,21,44,23,42,53,46,55,48,33,52,35,50,65,54,67
56,37,60,39,58,69,62,71,64,25,68,27,66,57,70,59
72,29,76,31,74,61,78,63,01,41,05,43,03,73,07,75
09,45,13,47,11,77,15,00,64,49,66,53,68,02,70,06
01,51,03,55,05,04

1.5 EQUALLY AVERAGE USE OF FREQUENCIES AND BEHAVIOUR

The generation of the hopping sequence in connection mode depends essentially on two input values:

1 LAP/UAP of the master of the connection

2 Internal master clock

The LAP(lower address part) are the 24 LSB's of the 48 BD_ADDRESS. The BD_ADDRESS is an unambiguous number of every Bluetooth unit. The UAP(upper address part) are the 24MSB's of the 48BD_ADDRESS

The internal clock of a Bluetooth unit is derived from a free running clock which is never adjusted and is never turned off. For synchronization with other units only offset are used. It has no relation to the time of the day. Its resolution is at least half the RX/TX slot length of 312.5us. The clock has a cycle of about one day(23h30). In most cases it is implemented as 28 bit counter. For the deriving of the hopping sequence the entire.

LAP(24 bits),4LSB's(4bits)(Input 1) and the 27MSB's of the clock(Input 2) are used. With this input values different mathematical procedures(permutations, additions, XOR-operations)are performed to generate the

Sequence. This will be done at the beginning of every new transmission.

Regarding short transmissions the Bluetooth system has the following behavior:

The first connection between the two devices is established, a hopping sequence was generated. For transmitting the wanted data the complete hopping sequence was not used. The connection ended.

The second connection will be established. A new hopping sequence is generated. Due to the fact the Bluetooth clock has a different value, because the period between the two transmission is longer(and it cannot be shorter)than the minimum resolution of the clock(312.5us).The hopping sequence will always differ from the first one.

1.6 RELATED SUBMITTAL(S) / GRANT (S)

This submittal(s) (test report) is intended for **FCC ID: ZJVMT-5000** filing to comply with Section 15.247 of the FCC Part 15, Subpart C Rules.

1.7 TEST METHODOLOGY

Both conducted and radiated testing were performed according to the procedures in ANSI C63.4 (2003). Radiated testing was performed at an antenna to EUT distance 3 meters.

1.8 TEST FACILITY

All measurement facilities used to collect the measurement data are located at
Attestation of Global Compliance Co., Ltd.

1F., No.2 Building, Huafeng No.1 Technical Industrial Park, Sanwei, Xixiang, Baoan District, Shenzhen

The test site is constructed and calibrated to meet the FCC requirements in documents ANSI C63.4: 2003.

FCC register No.: 259865

1.9 SPECIAL ACCESSORIES

Refer to section 2.2.

1.10 EQUIPMENT MODIFICATIONS

Not available for this EUT intended for grant.

2 SYSTEM TEST CONFIGURATION

2.1 CONFIGURATION OF TESTED SYSTEM

Configure 1(Normal Hopping mode)

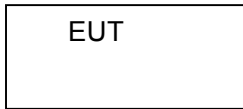

Configure 2(Controlled by PC to transmit continuously on the setting channel for testing)

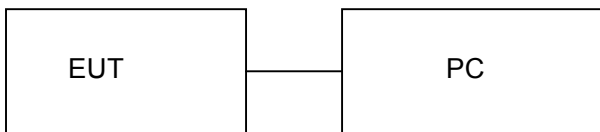

2.2 EQUIPMENT USED IN TESTED SYSTEM

Item	Equipment	Mfr/Brand	Model/Type No.	Remark
1	Bluetooth Headset	N/A	MT-5000	EUT
2	PC	Lenovo	B450	A.E.
3	PC	Lenovo	A6000K	A.E.
4	USB Cable	N/A	N/A	A.E.

3 SUMMARY OF TEST RESULTS

FCC RULES	DESCRIPTION OF TEST	RESULT
§15.247	Peak Output Power	Compliant
§15.247	20 dB Bandwidth	Compliant
§15.247	Conducted Spurious Emission	Compliant
§15.209	Radiated Emission	Compliant
§15.247	Band Edges	Compliant
§15.247	Number of Hopping Frequency	Compliant
§15.247	Time of Occupancy	Compliant
§15.247	Frequency Separation	Compliant
§15.207	Line Conduction Emission	NA

4. DESCRIPTION OF TEST MODES

The EUT has been set to operate for three modulations: GFSK, $\pi/4$ -DQPSK, 8-DPSK independently. For each kind of modulation, the following modes were chosen for testing.

No.	TEST MODES
1	Low Channel(TX)
2	Middle Channel(TX)
3	High Channel(TX)
4	Normal Hopping

Note: All test modes were performed during the test, only the test data of the worst mode was recorded for each test item listed in the test Report.

5 PEAK OUTPUT POWER

5.1 MEASUREMENT PROCEDURE

1. The EUT was placed on a turn table which is 0.8m above ground plane.
2. Connect EUT RF output port to the Spectrum Analyzer through an RF attenuator
3. Set the EUT Work on the top, the middle and the bottom operation frequency individually.
4. Set Span = approximately 5 times the 20 dB bandwidth, centered on a hopping channel, RBW > the 20 dB bandwidth of the emission being measured, VBW \geq RBW
5. Set SPA Trace 1 Max hold, then View.

5.2 TEST SET-UP (BLOCK DIAGRAM OF CONFIGURATION)

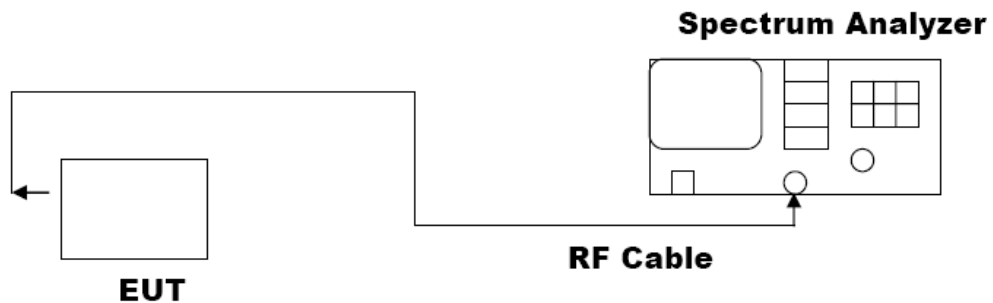

5.3 MEASUREMENT EQUIPMENT USED

Description	Manufacturer	Model	SERIAL NUMBER	Cal. Date	Cal. Due
Spectrum Analyzer	Agilent	E4440A	N/A	06/29/2010	06/28/2011

5.4 LIMITS AND MEASUREMENT RESULT

PEAK POWER LIMITS AND MEASUREMENT RESULT					
Frequency (GHz)	GFSK (dBm)	π /4-DQPSK (dBm)	8-DPSK (dBm)	Applicable Limits (dBm)	Pass or Fail
2.402	3.79	3.42	3.23	30	Pass
2.441	3.86	3.51	3.28	30	Pass
2.480	3.88	3.49	3.33	30	Pass

6 20 DB BANDWIDTH

6.1 MEASUREMENT PROCEDURE

1. The EUT was placed on a turn table which is 0.8m above ground plane.
2. Connect EUT RF output port to the Spectrum Analyzer through an RF attenuator
3. Set the EUT Work on the top, the middle and the bottom operation frequency individually.
4. Set Span = approximately 2 to 3 times the 20 dB bandwidth, centered on a hopping channel
RBW \geq 1% of the 20 dB bandwidth, VBW \geq RBW.
5. Set SPA Trace 1 Max hold, then View.

6.2 TEST SET-UP (BLOCK DIAGRAM OF CONFIGURATION)

The Same as described in Section 5.2

6.3 MEASUREMENT EQUIPMENT USED

The same as described in Section 5.3

6.4 LIMITS AND MEASUREMENT RESULTS

LIMITS AND MEASUREMENT RESULT FOR THE WORST CASE OF 8-DPSK MODULATION WITH 3MBPS DATA RATE			
Applicable Limits	Measurement Result		
	Test Result (MHz)		Criteria
Within the Authorized frequency band: 2400 MHz to 2483.5 MHz	Low Channel	1.387	PASS
	Middle Channel	1.380	PASS
	High Channel	1.383	PASS

TEST PLOT OF BANDWIDTH FOR LOW CHANNEL

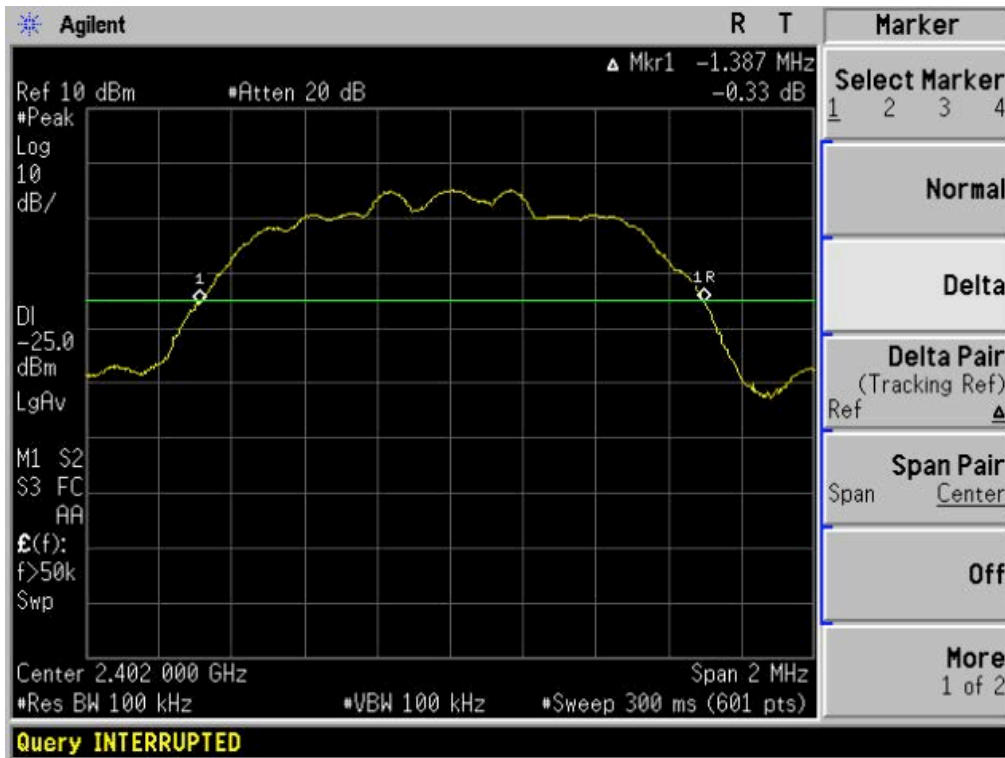

TEST PLOT OF BANDWIDTH FOR MIDDLE CHANNEL

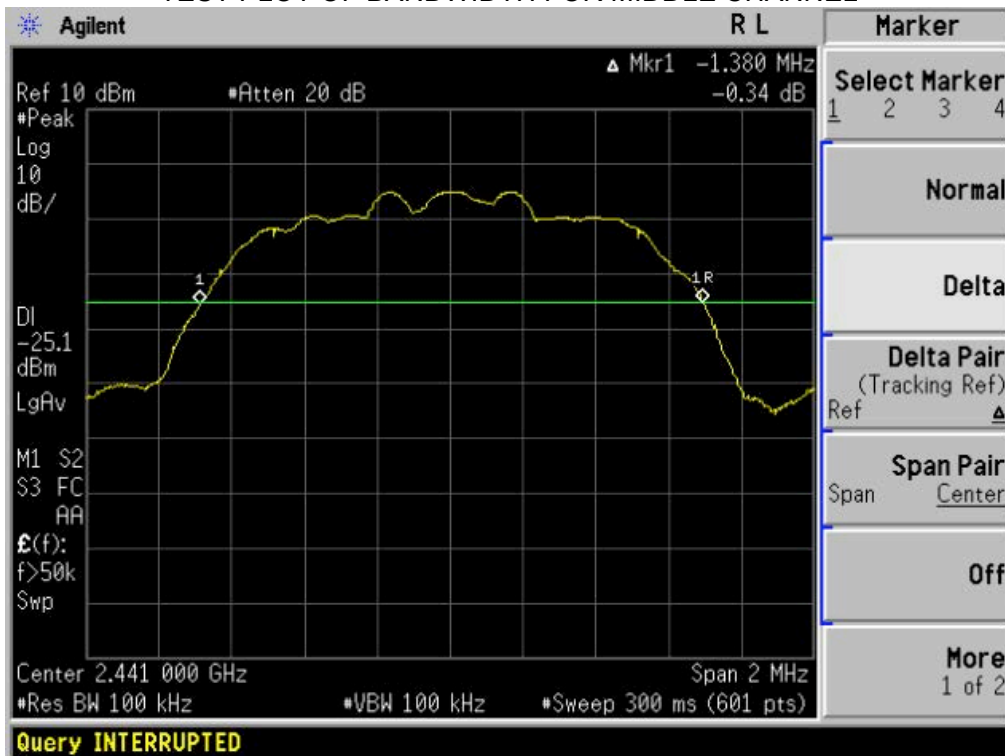

TEST PLOT OF BANDWIDTH FOR HIGH CHANNEL

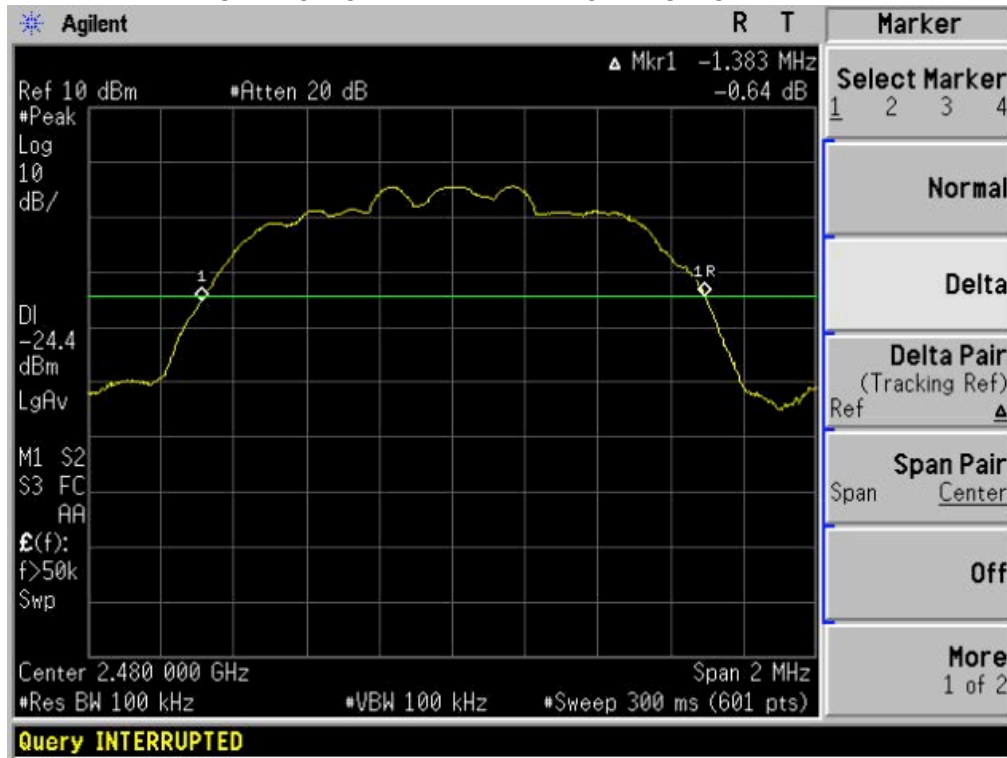

7. MAXIMUM CONDUCTED OUTPUT POWER SPECTRAL DENSITY

Not applicable for Bluetooth Device (Frequency Hopping Device)

8. CONDUCTED SPURIOUS EMISSION

8.1 MEASUREMENT PROCEDURE

1. The EUT was placed on a turn table which is 0.8m above ground plane.
2. Connect EUT RF output port to the Spectrum Analyzer through an RF attenuator
3. Set the EUT Work on the top, the middle and the bottom operation frequency individually.
4. Set Span = wide enough to capture the peak level of the in-band emission and all spurious emissions (e.g., harmonics) from the lowest frequency generated in the EUT up through the 10th harmonic. several plots are provided to cover this entire span.
RBW = 100 kHz, VBW ≥ RBW
5. Set SPA Trace 1 Max hold, then View.

8.2 TEST SET-UP (BLOCK DIAGRAM OF CONFIGURATION)

The Same as described in section 5.2

8.3 MEASUREMENT EQUIPMENT USED

The Same as described in section 5.3

8.4 LIMITS AND MEASUREMENT RESULT

LIMITS AND MEASUREMENT RESULT		
Applicable Limits	Measurement Result	
	Test Data	Criteria
<p>In any 100 KHz Bandwidth Outside the frequency band in which the spread spectrum intentional radiator is operating, the radio frequency power that is produce by the intentional radiator shall be at least 20 dB below that in 100KHz bandwidth within the band that contains the highest level of the desired power.</p>	<p>At least -20dBc than the limit Specified on the BOTTOM Channel</p>	<p>PASS</p>
<p>In addition, radiation emissions which fall in the restricted bands, as defined in §15.205(a), must also comply with the radiated emission limits specified in§15.209(a))</p>	<p>At least -20dBc than the limit Specified on the TOP Channel</p>	<p>PASS</p>

TEST PLOT OF OUT OF BAND EMISSIONS FOR THE WORST CASE
OF TOP CHANNEL GFSK MODULATED WITH DATA RATE 1MBPS

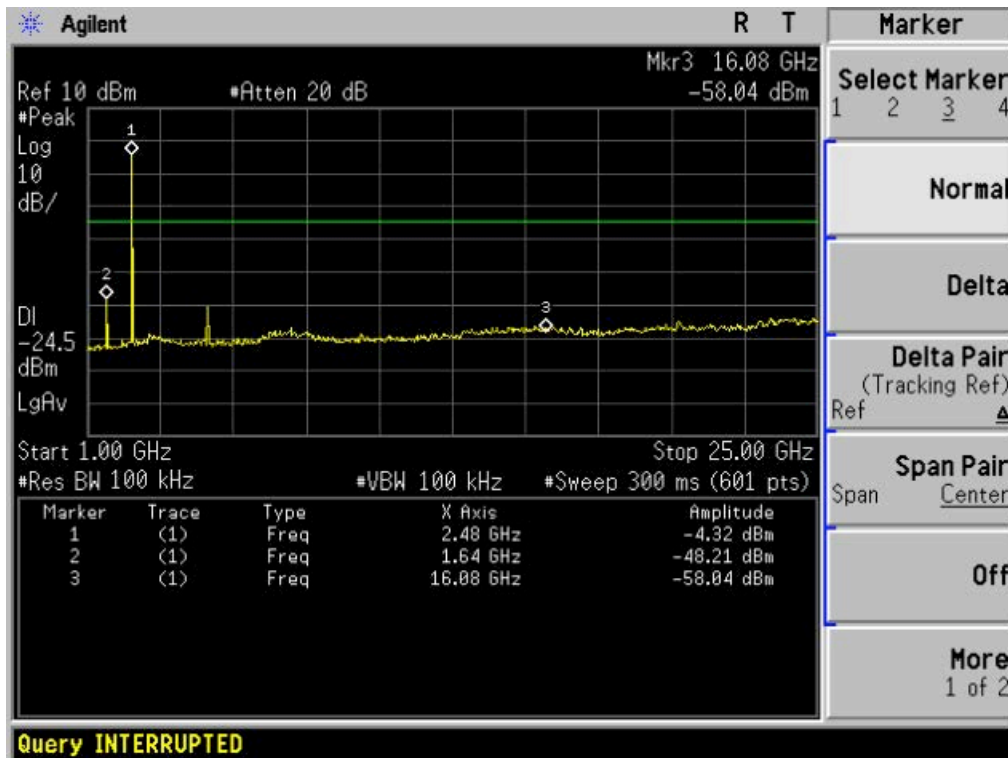
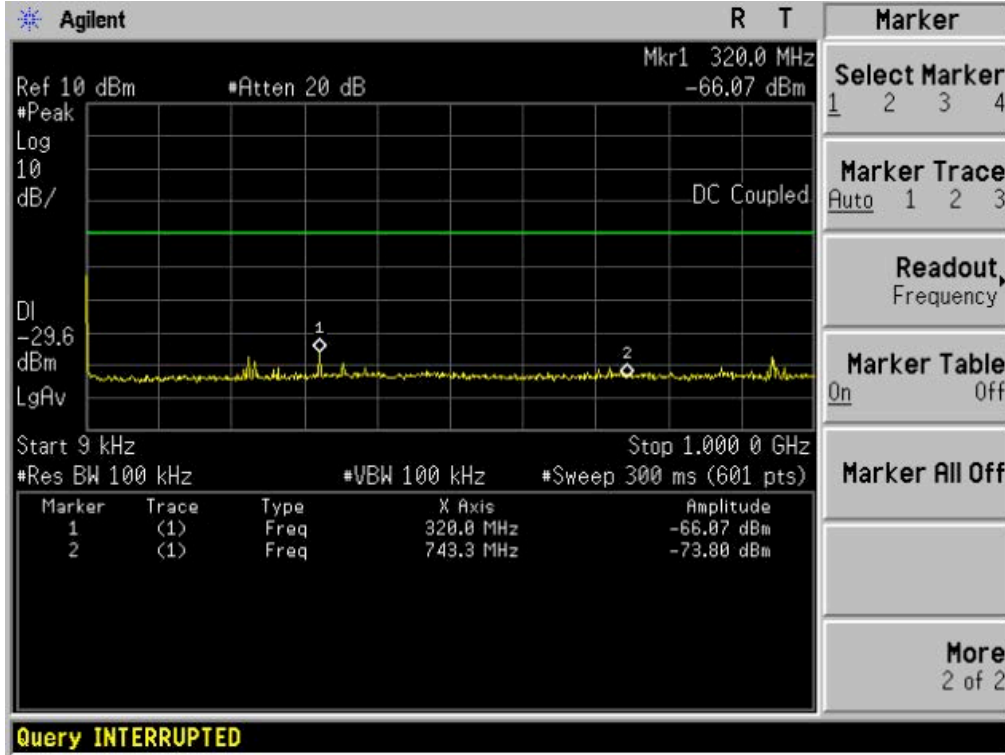

9. RADIATED EMISSION FOR RESTRICTED BAND

9.1 MEASUREMENT PROCEDURE

1. Configure the EUT according to ANSI C63.4. The EUT was placed on the top of the turntable 0.8 meter above ground. The phase center of the receiving antenna mounted on the top of a height-variable antenna tower was placed 3 meters far away from the turntable.
2. Power on the EUT and all the supporting units. The turntable was rotated by 360 degrees to determine the position of the highest radiation.
3. The height of the broadband receiving antenna was varied between one meter and four meters above ground to find the maximum emissions field strength of both horizontal and vertical polarization.
4. For each suspected emissions, the antenna tower was scan (from 1 M to 4 M) and then the turntable was rotated (from 0 degree to 360 degrees) to find the maximum reading.
5. Set the test-receiver system to Peak or CISPR quasi-peak Detect Function with specified bandwidth under Maximum Hold Mode.
6. For emissions above 1GHz, use 1MHz VBW and RBW for peak reading. Then 1MHz RBW and 10Hz VBW for average reading in spectrum analyzer.
7. When the radiated emissions limits are expressed in terms of the average value of the emissions, and pulsed operation is employed, the measurement field strength shall be determined by averaging over one complete pulse train, including blanking intervals, as long as the pulse train does not exceed 0.1 seconds. As an alternative (provided the transmitter operates for longer than 0.1 seconds) or in cases where the pulse train exceeds 0.1 seconds, the measured field strength shall be determined from the average absolute voltage during a 0.1 second interval during which the field strength is at its maximum value.
8. If the emissions level of the EUT in peak mode was 3 dB lower than the average limit specified, then testing will be stopped and peak values of EUT will be reported, otherwise, the emissions which do not have 3 dB margin will be repeated one by one using the quasi-peak method for below 1GHz.
9. For testing above 1GHz, the emissions level of the EUT in peak mode was lower than average limit (that means the emissions level in peak mode also complies with the limit in average mode), then testing will be stopped and peak values of EUT will be reported, otherwise, the emissions will be measured in average mode again and reported.
10. In case the emission is lower than 30MHz, loop antenna has to be used for measurement and the recorded data should be QP measured by receiver. High – Low scan is not required in this case.

The following table is the setting of spectrum analyzer and receiver.'

Spectrum Parameter	Setting
Start Frequency	1GHz
Stop Frequency	26.5GHz
RB/VB(Emission in restricted band)	1MHz/1MHz for Peak, 1MHz/10Hz for Average
RB/VB(Emission in non-restricted band)	1MHz/1MHz for Peak

Receiver Parameter	Setting
Start ~Stop Frequency	9KHz~150KHz/RB 200Hz for QP
Start ~Stop Frequency	150KHz~30MHz/RB 9KHz for QP
Start ~Stop Frequency	30MHz~1000MHz/RB 120KHz for QP

9.2 TEST SETUP

RADIATED EMISSION TEST SETUP BELOW 30MHz

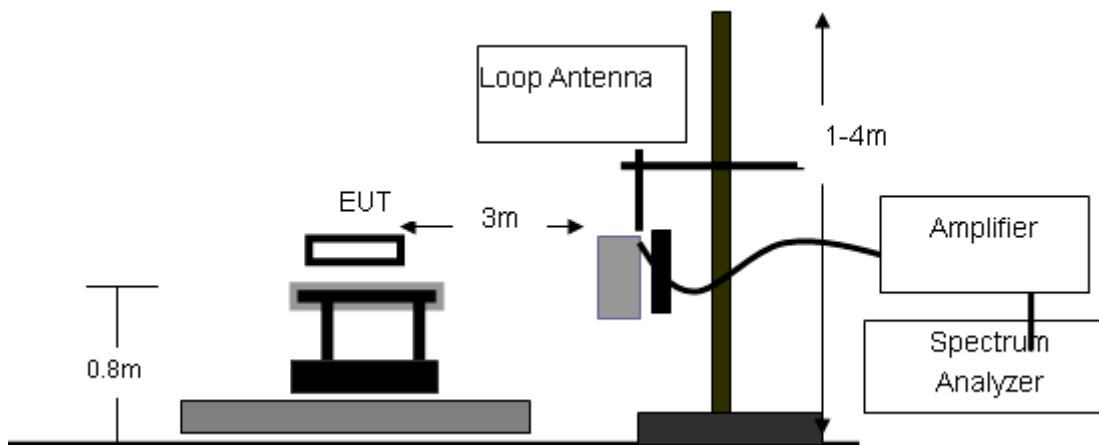

RADIATED EMISSION TEST SETUP 30MHz-1000MHz

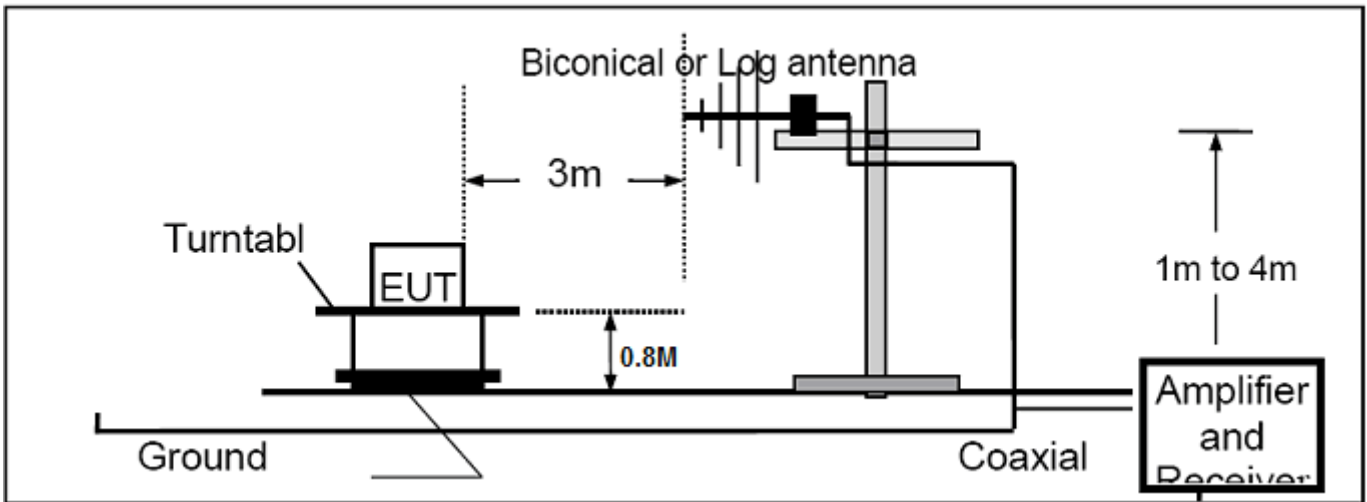

RADIATED EMISSION TEST SETUP ABOVE 1000MHz

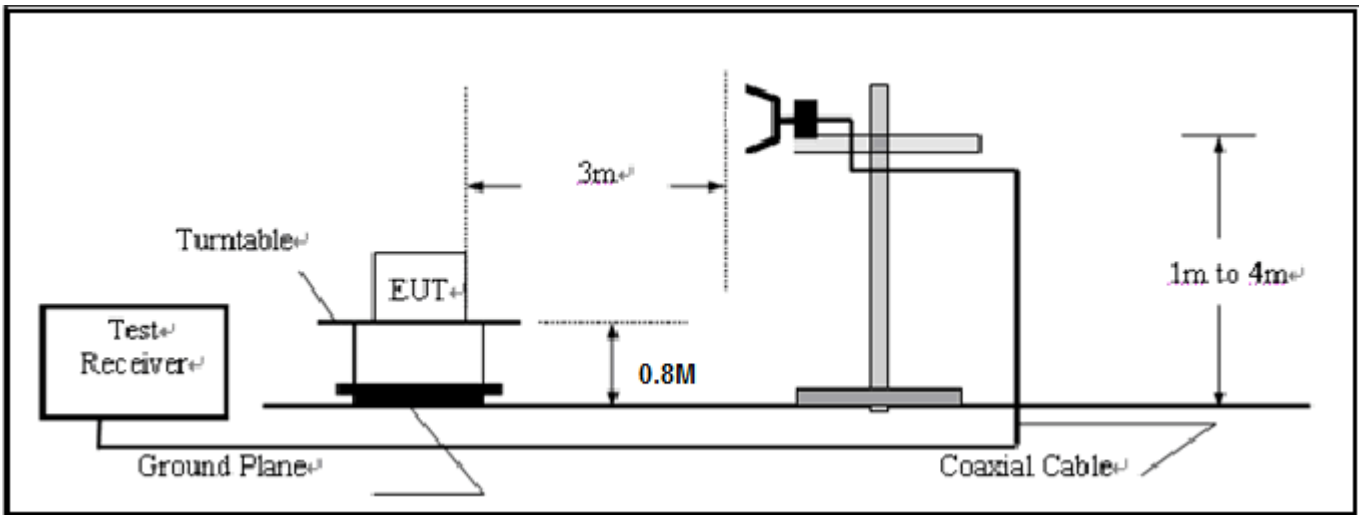

9.2 TEST EQUIPMENT LIST

Description	Manufacturer	Model	SERIAL NUMBER	Cal. Date	Cal. Due
Spectrum Analyzer	Agilent	E4440A	N/A	06/29/2010	06/28/2011
Amplifier	EM	EM30180	0607030	06/29/2010	06/28/2011
Horn Antenna	EM	EM-AH-10180	N/A	06/29/2010	06/28/2011
Horn Antenna	A.H. Systems Inc.	SAS-574	--	06/29/2010	06/28/2011
EMI Test Receiver	Rohde & Schwarz	ESCI	N/A	06/29/2010	06/28/2011
Amplifier	EM	EM30180	N/A	06/29/2010	06/28/2011
Biological Antenna	A.H. Systems Inc.	SAS-521-4	N/A	06/29/2010	06/28/2011
Loop Antenna	Daze	ZN30900N	SEL0097	06/29/2010	06/28/2011
Isolation Transformer	LETEAC	LTBK	--	06/29/2010	06/28/2011

9.3 TEST RESULT

RADIATED EMISSION BELOW 30MHZ

No emission found between lowest internal used/generated frequency to 30MHz.

RADIATED EMISSION BELOW 1GHZ

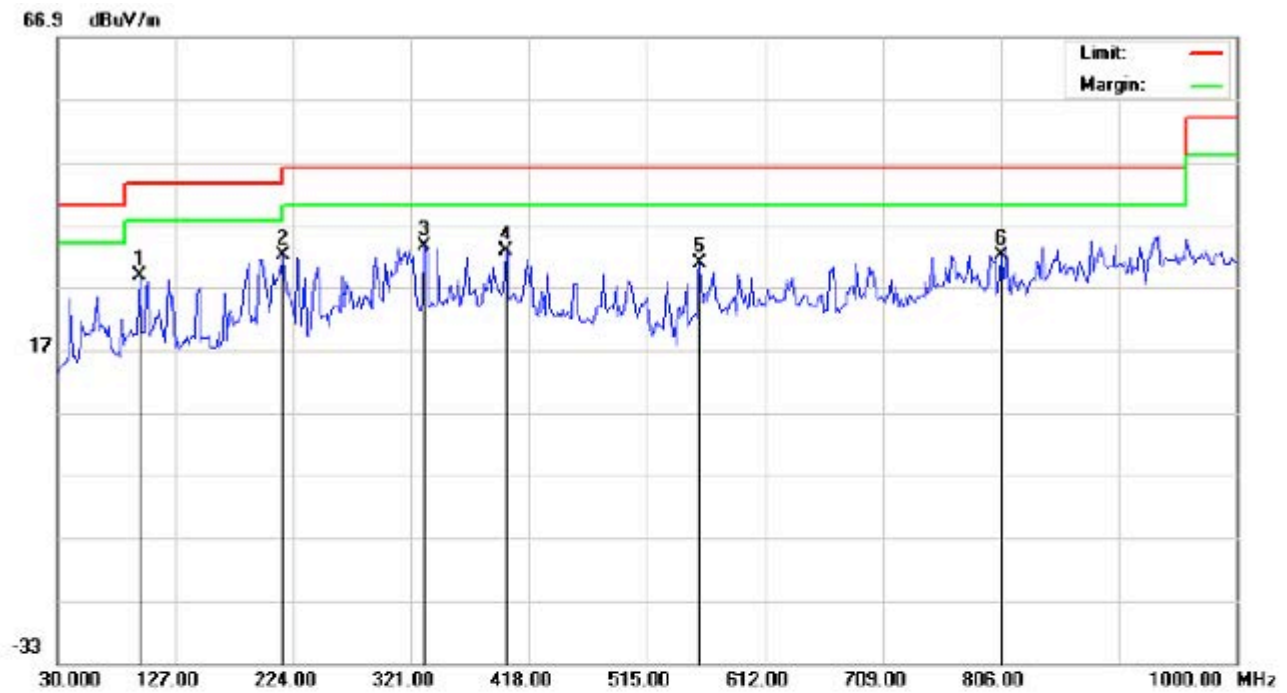

Site: site #1	Polarization: <i>Horizontal</i>	Temperature: 26
Limit: FCC Class B 3M Radiation	Power:	Humidity: 60 %
EUT: Bluetooth Headset	Distance: 3m	
M/N: MT-5000		
Mode: 2441TX		
Note:		

No.	Mk	Freq.	Reading	Factor	Measurement	Limit	Over	Detector	Antenna Height	Table Degree	Comment
		MHz	dBuV	dB/m	dBuV/m	dBuV/m	dB		cm	degree	
1		97.9000	14.82	13.89	28.71	43.50	-14.79	peak			
2	*	215.9167	19.05	12.93	31.98	43.50	-11.52	peak			
3		332.3167	14.74	18.72	33.46	46.00	-12.54	peak			
4		398.6000	11.97	20.72	32.69	46.00	-13.31	peak			
5		558.6500	7.04	23.75	30.79	46.00	-15.21	peak			
6		806.0000	3.98	28.05	32.03	46.00	-13.97	peak			

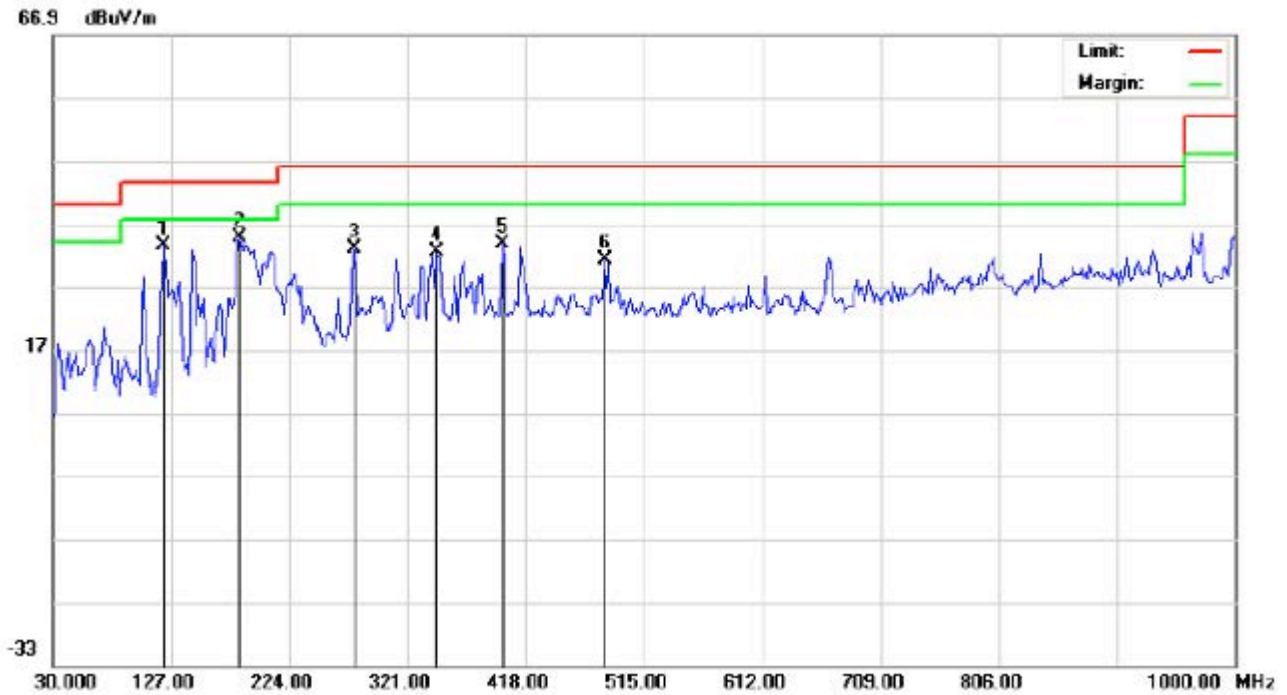

Site: site #1
 Limit: FCC Class B 3M Radiation
 EUT: Bluetooth Headset
 M/N: MT-5000
 Mode: 2441TX
 Note:

Polarization: *Vertical*
 Power:
 Distance: 3m

Temperature: 26
 Humidity: 60 %

No.	Mk	Freq.	Reading	Factor	Measurement	Limit	Over	Detector	Antenna Height	Table Degree	Comment
		MHz	dBuV	dB/m	dBuV/m	dBuV/m	dB		cm	degree	
1		120.5333	19.41	14.22	33.63	43.50	-9.87	peak			
2	*	183.5833	16.82	18.07	34.89	43.50	-8.61	peak			
3		277.3500	15.91	17.20	33.11	46.00	-12.89	peak			
4		345.2500	13.49	19.01	32.50	46.00	-13.50	peak			
5		398.6000	13.06	20.72	33.78	46.00	-12.22	peak			
6		482.6667	9.34	21.84	31.18	46.00	-14.82	peak			

RADIATED EMISSION ABOVE 1GHZ(1-10th Harmonics)

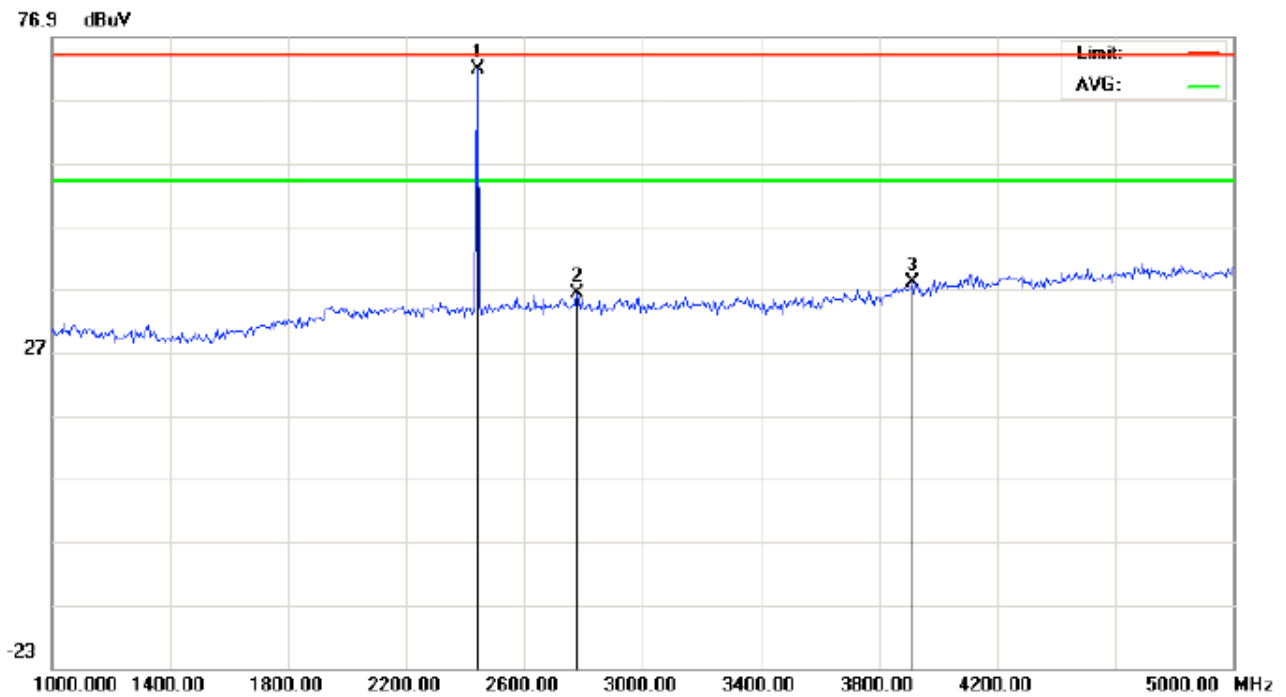

Site: site #1
Limit: FCC Class B 3M Radiation above 1GHZ(PK)
EUT: Bluetooth Headset
M/N: 2441TX
Mode: MT-5000
Note:

Polarization: *Horizontal*
Power:
Distance: 3m

Temperature: 26
Humidity: 60 %

No.	Mk	Freq.	Reading	Factor	Measurement	Limit	Over	Detector	Antenna Height	Table Degree	Comment
		MHz	dBuV	dB	dBuV	dBuV	dB		cm	degree	
1	*	2441.000	81.31	-9.64	71.67	74.00	-2.33	peak			
2		2780.000	45.14	-8.89	36.25	74.00	-37.75	peak			
3		3913.333	43.39	-5.34	38.05	74.00	-35.95	peak			

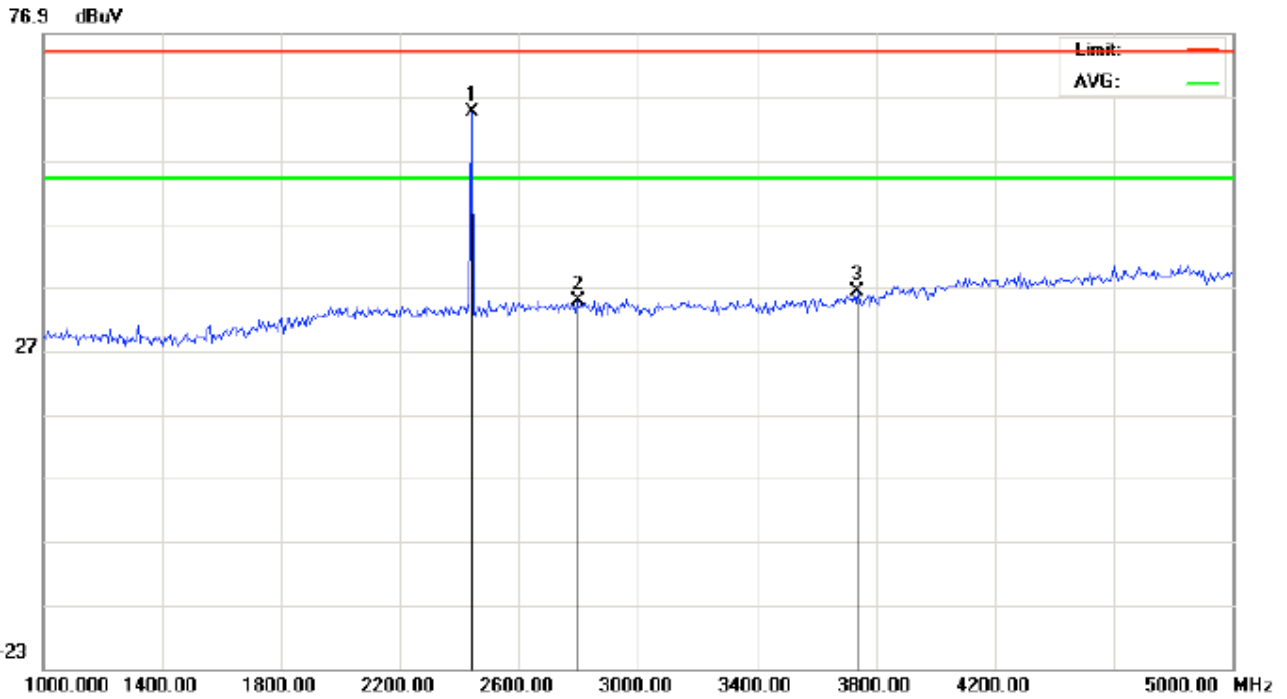

Site: site #1 Polarization: *Vertical* Temperature: 26
 Limit: FCC Class B 3M Radiation above 1GHZ(PK) Power: Humidity: 60 %
 EUT: Bluetooth Headset Distance: 3m
 M/N: 2441TX
 Mode: MT-5000
 Note:

No.	Mk	Freq.	Reading	Factor	Measurement	Limit	Over	Detector	Antenna Height	Table Degree	Comment
		MHz	dBuV	dB	dBuV	dBuV	dB		cm	degree	
1	*	2441.000	74.08	-9.64	64.44	74.00	-9.56	peak			
2		2800.000	43.72	-8.84	34.88	74.00	-39.12	peak			
3		3740.000	42.58	-6.41	36.17	74.00	-37.83	peak			

Note: 5~25GHz at least have 20dB margin. no recording in the test report.
 Factor=Antenna Factor+ Cable loss-Amplifier gain, Margin=Measurement-Limit.

10 BAND EDGES EMISSION

10.1 MEASUREMENT PROCEDURE

- 1, Set the EUT Work on the top, the bottom operation frequency individually.
- 2, Set Span = wide enough to capture the peak level of the emission operating on the channel closest to the bandedge, as well as any modulation products which fall outside of the authorized band of operation
RBW \geq 1% of the span VBW \geq RBW
3. The band edges was measured and recorded.

10.2 TEST SET-UP

The Same as described in section 9.2

10.3 TEST RESULT

TEST PLOT OF BAND EDGE FOR LOW CHANNEL(3Mbps)



Site: site #1	Polarization: <i>Horizontal</i>	Temperature: 26
Limit: FCC Class B 3M Radiation above 1GHZ(PK)	Power:	Humidity: 60 %
EUT: Bluetooth Headset	Distance: 3m	
MN: MT-5000		
Mode: 2402TX		
Note:		

No.	Mk	Freq.	Reading	Factor	Measurement	Limit	Over	Detector	Antenna Height	Table Degree	Comment
		MHz	dBuV	dB/m	dBuV/m	dBuV/m	dB		cm	degree	
1		2390.300	44.58	-9.69	34.89	74.00	-39.11	peak			
2		2400.000	46.11	-9.68	36.43	74.00	-37.57	peak			
3	*	2402.000	86.05	-9.68	76.37	74.00	2.37	peak			

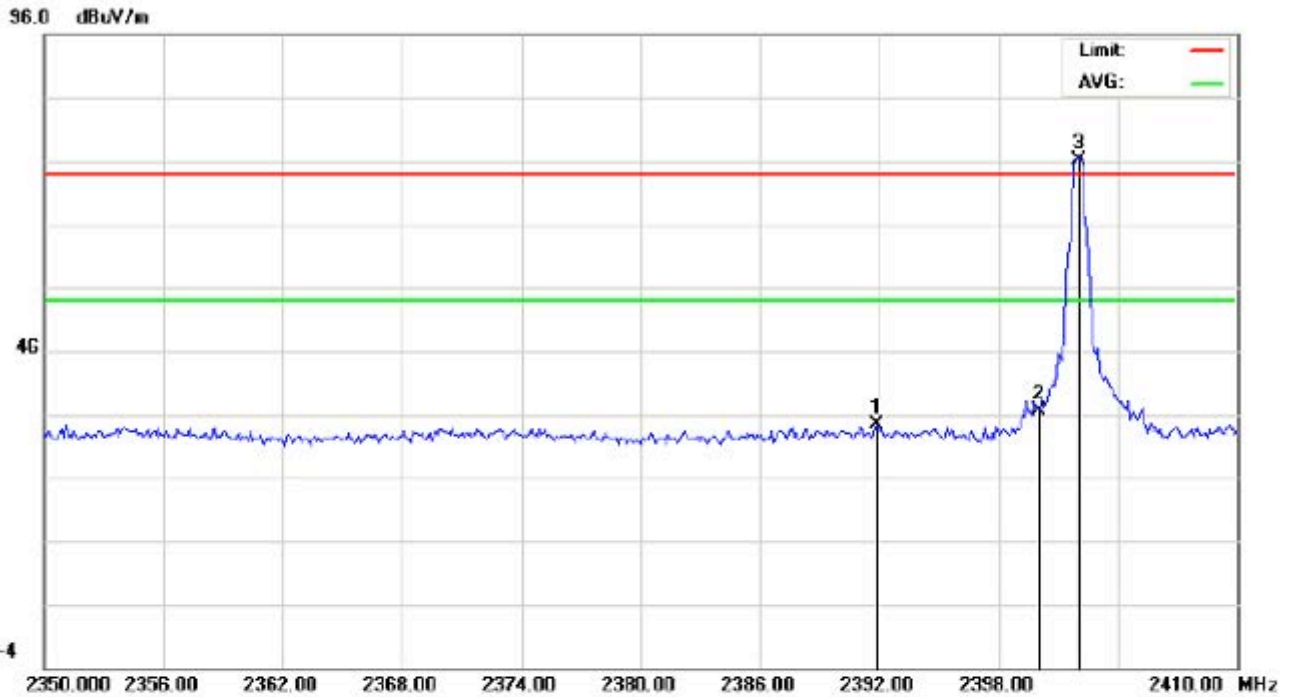

Site: site #1
Limit: FCC Class B 3M Radiation above 1GHZ(PK)
EUT: Bluetooth Headset
MN: MT-5000
Mode: 2402TX
Note:

Polarization: *Vertical*
Power:
Distance: 3m

Temperature: 26
Humidity: 60 %

No.	Mk	Freq.	Reading	Factor	Measurement	Limit	Over	Detector	Antenna Height	Table Degree	Comment
		MHz	dBuV	dB/m	dBuV/m	dBuV/m	dB		cm	degree	
1		2391.900	44.15	-9.69	34.46	74.00	-39.54	peak			
2		2400.000	46.26	-9.68	36.58	74.00	-37.42	peak			
3	*	2402.000	85.71	-9.68	76.03	74.00	2.03	peak			

TEST PLOT OF BAND EDGE FOR HIGH CHANNEL(3Mbps)

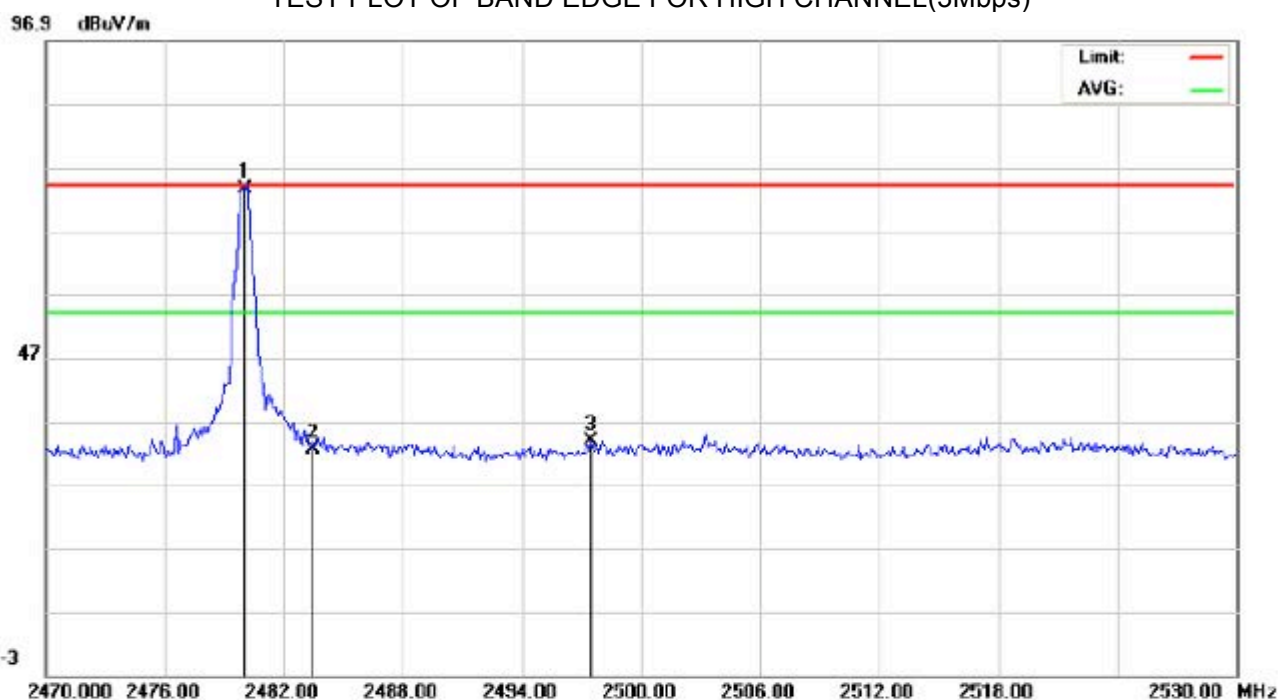

Site: site #1
 Limit: FCC Class B 3M Radiation above 1GHZ(PK)
 EUT: Bluetooth Headset
 MN: MT-5000
 Mode: 2480TX
 Note:

Polarization: *Horizontal*
 Power:
 Distance: 3m

Temperature: 26
 Humidity: 60 %

No.	Mk	Freq.	Reading	Factor	Measurement	Limit	Over	Detector	Antenna Height	Table Degree	Comment
		MHz	dBuV	dB/m	dBuV/m	dBuV/m	dB		cm	degree	
1	*	2480.000	83.11	-9.59	73.52	74.00	-0.48	peak			
2		2483.500	42.19	-9.59	32.60	74.00	-41.40	peak			
3		2497.500	43.28	-9.57	33.71	74.00	-40.29	peak			

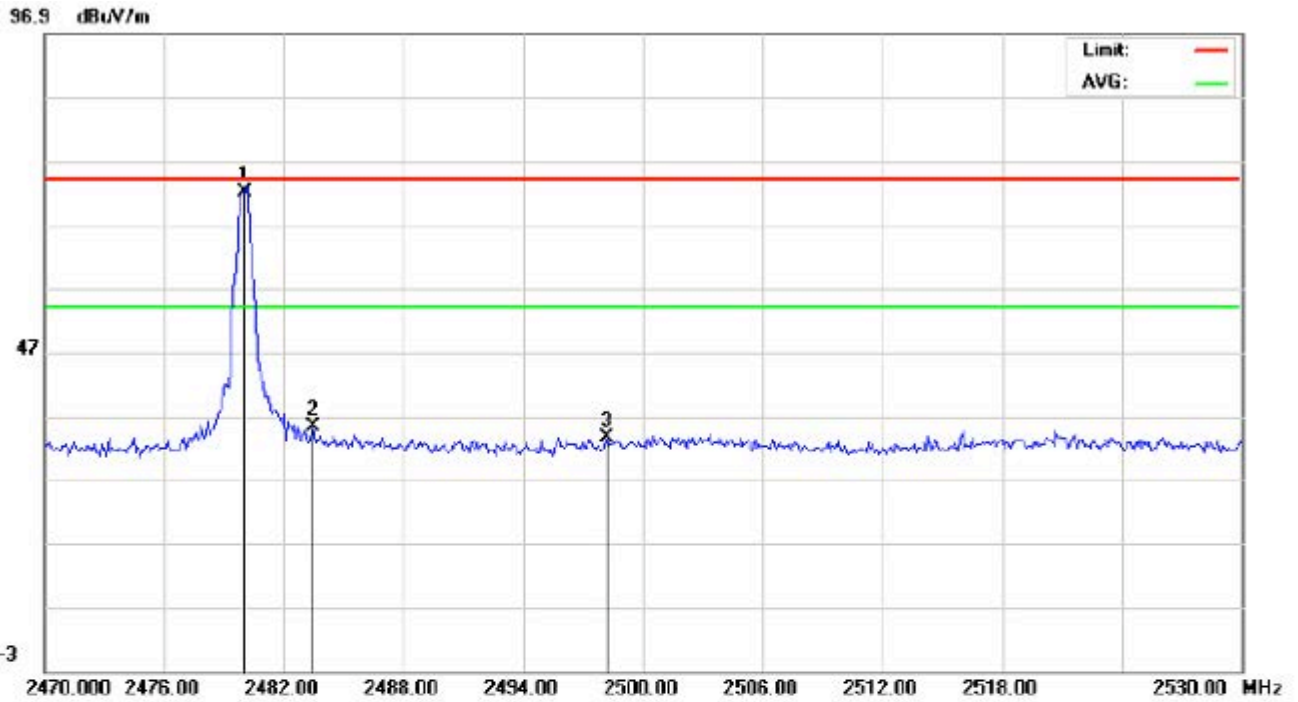

Site: site #1
Limit: FCC Class B 3M Radiation above 1GHZ(PK)
EUT: Bluetooth Headset
MN: MT-5000
Mode: 2480TX
Note:

Polarization: *Vertical*
Power:
Distance: 3m

Temperature: 26
Humidity: 60 %

No.	Mk	Freq.	Reading	Factor	Measurement	Limit	Over	Detector	Antenna Height	Table Degree	Comment
		MHz	dBuV	dB/m	dBuV/m	dBuV/m	dB		cm	degree	
1	*	2480.000	81.55	-9.59	71.96	74.00	-2.04	peak			
2		2483.500	44.94	-9.59	35.35	74.00	-38.65	peak			
3		2498.200	43.06	-9.57	33.49	74.00	-40.51	peak			

11 NUMBER OF HOPPING FREQUENCY

11.1 MEASUREMENT PROCEDURE

1. Place the EUT on the table and set it in transmitting mode.
2. Remove the antenna from the EUT and then connect a low RF cable from the antenna port to the spectrum analyzer.
3. Set the spectrum analyzer Start = 2.4GHz Stop = 2.4835GHz
4. Set the Spectrum Analyzer as RBW>=1%span, VBW>=RBW.

11.2 TEST SETUP (BLOCK DIAGRAM OF CONFIGURATION)

Same as described in section 5.2
Conducted Method.

11.3 MEASUREMENT EQUIPMENT USED

The Same as described in section 5.3

11.4 LIMITS AND MEASUREMENT RESULT

TOTAL NO. OF HOPPING CHANNEL	LIMIT (NO. OF CH)	MEASUREMENT (NO. OF CH)	RESULT
	>=15	79	PASS

TEST PLOT FOR NO. OF TOTAL CHANNELS

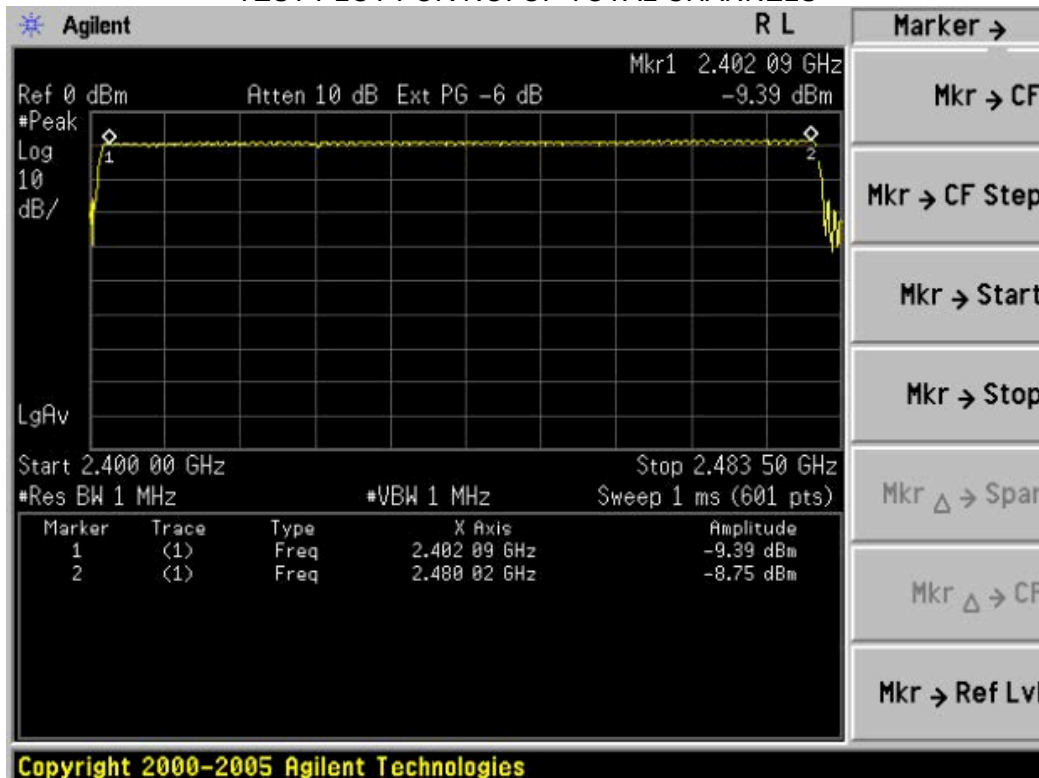

12 TIME OF OCCUPANCY (DWELL TIME)

12.1 MEASUREMENT PROCEDURE

1. Place the EUT on the table and set it in transmitting mode
2. Remove the antenna from the EUT and then connect a low RF cable from the antenna port to the spectrum analyzer
3. Set center frequency of spectrum analyzer = Operating frequency
4. Set the spectrum analyzer as RBW=1MHz, VBW>=RBW, Span = 0 Hz,.

12.2 TEST SETUP (BLOCK DIAGRAM OF CONFIGURATION)

Same as described in section 5.2
Conducted Method

12.3 MEASUREMENT EQUIPMENT USED

The same as described in section 5.3

12.4 LIMITS AND MEASUREMENT RESULT

Bluetooth 3Mbps Test Result

Channel	Time of Pulse for DH5 (ms)	Period Time (s)	Sweep Time (ms)	Limit (ms)
Low	2.905	31.6	309.87	400
Middle	2.905	31.6	309.87	400
High	2.917	31.6	311.15	400

Low Channel Time

$$2.905 \times (1600/6) / 79 \times 31.6 = 309.87 \text{ms}$$

Middle Channel Time

$$2.905 \times (1600/6) / 79 \times 31.6 = 309.87 \text{ms}$$

High Channel Time

$$2.917 \times (1600/6) / 79 \times 31.6 = 311.15 \text{ms}$$

TEST PLOT OF LOW CHANNEL

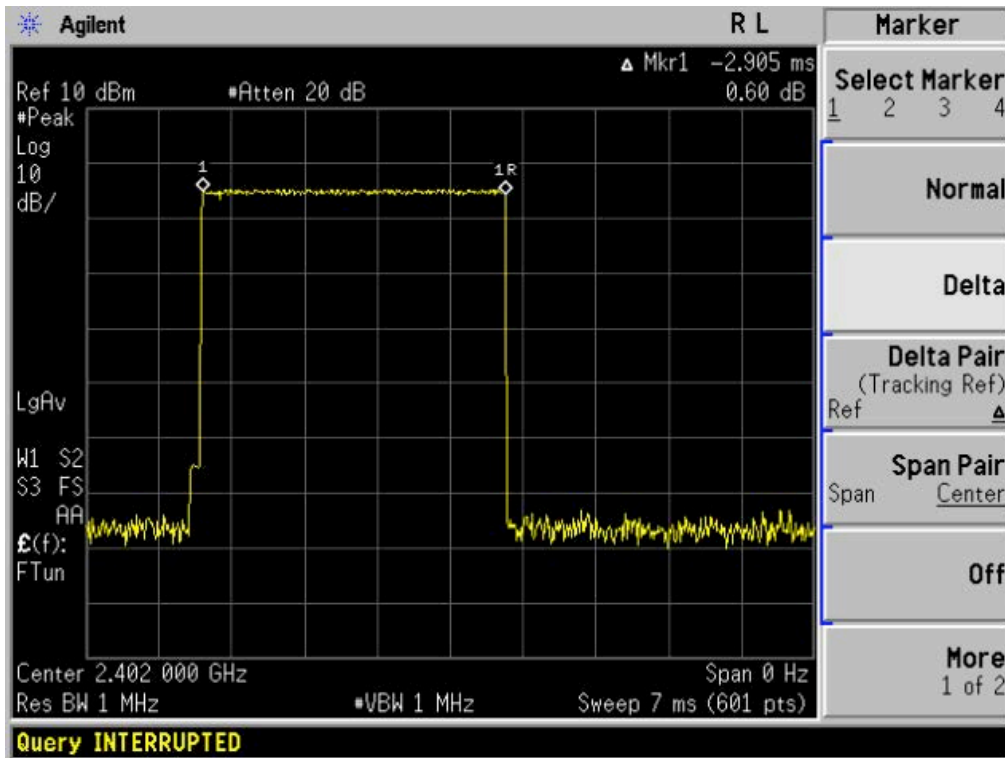

TEST PLOT OF MIDDLE CHANNEL

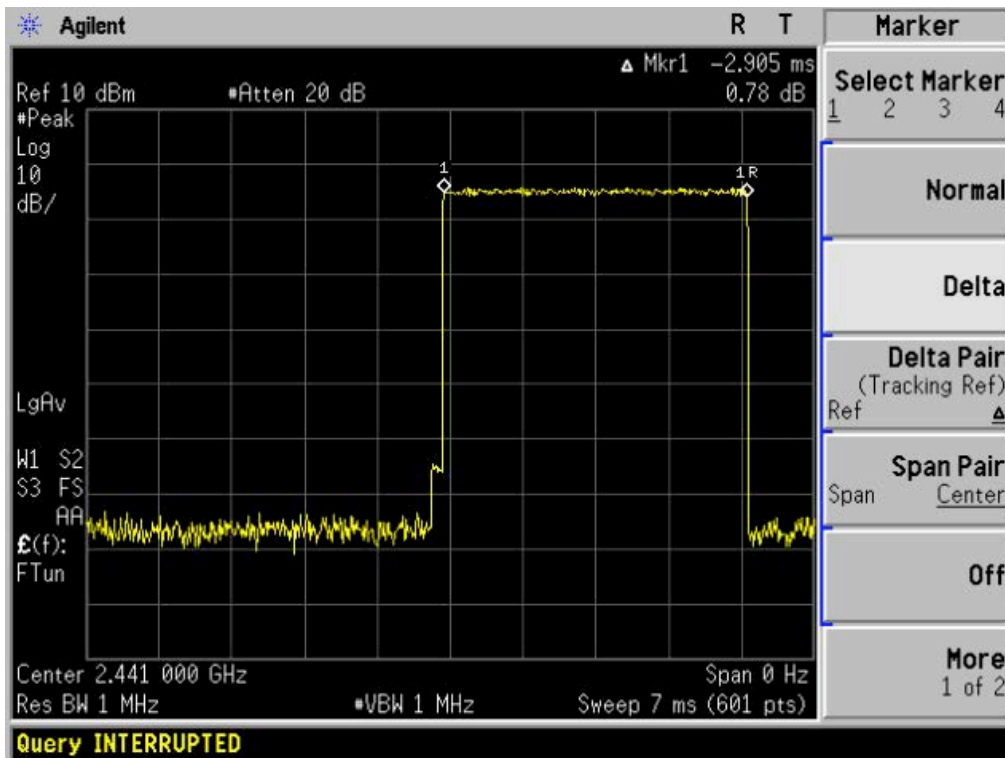

TEST PLOT OF HIGH CHANNEL

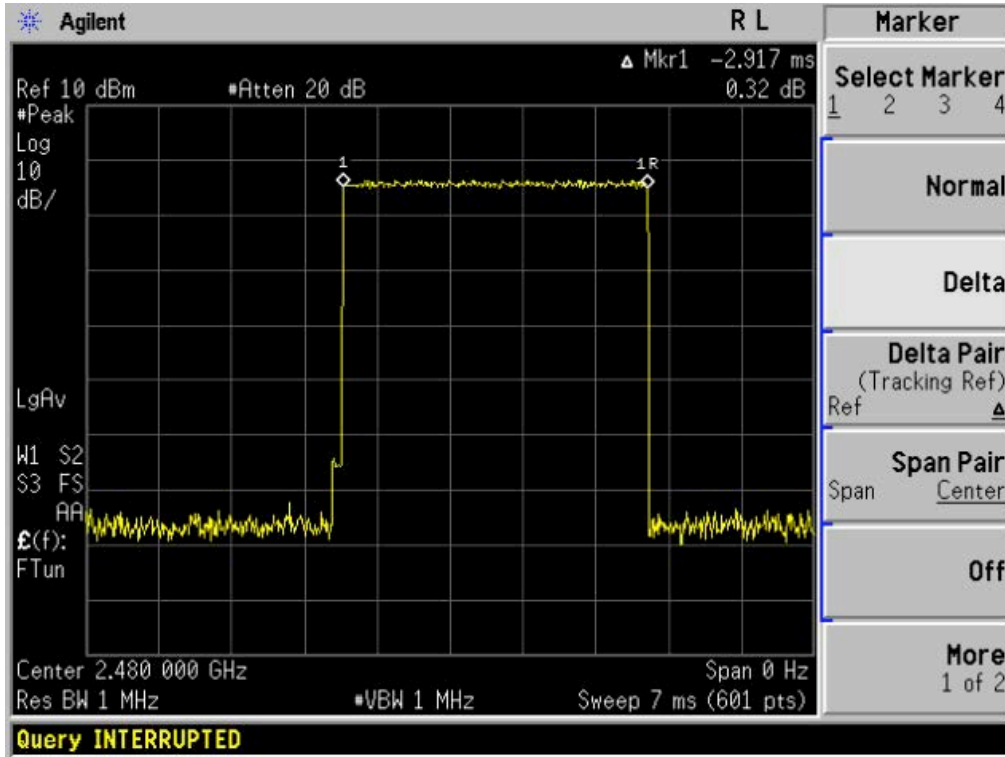

13. FREQUENCY SEPARATION

13.1 MEASUREMENT PROCEDURE

1. Place the EUT on the table and set it in transmitting mode
2. Remove the antenna from the EUT and then connect a low RF cable from the antenna port to the spectrum analyzer
3. Set Span = wide enough to capture the peaks of two adjacent channels
4. Set the spectrum analyzer as RBW \geq 1% of span, VBW \geq RBW

13.2 TEST SETUP (BLOCK DIAGRAM OF CONFIGURATION)

Same as described in section 5.2

13.3 MEASUREMENT EQUIPMENT USED

The same as described in section 5.3

13.4 LIMITS AND MEASUREMENT RESULT

BLUETOOTH 3MBPS TEST RESULT

CHANNEL	CHANNEL SEPARATION	LIMIT	RESULT
	KHz	KHz	
CH00-CH01	1025	\geq 25 KHz or 2/3 20 dB BW	Pass

TEST PLOT FOR FREQUENCY SEPARATION



14 FCC LINE CONDUCTED EMISSION TEST

The device is not able to work (Transmit or Receive) while being charged due to the device shall deactivated automatically while charging. So Line Conducted Emission test is not applicable.

APPENDIX I
PHOTOGRAPHS OF THE EUT

VIEW OF SAMPLE-1



VIEW OF SAMPLE-2



VIEW OF SAMPLE-3



OPEN VIEW OF EUT

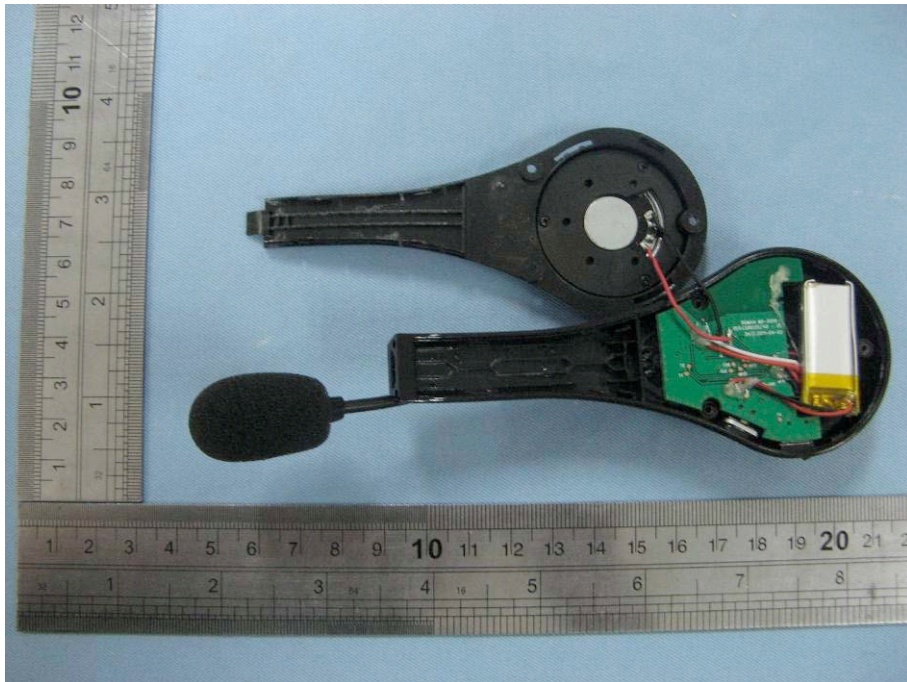

FRONT VIEW OF PCB

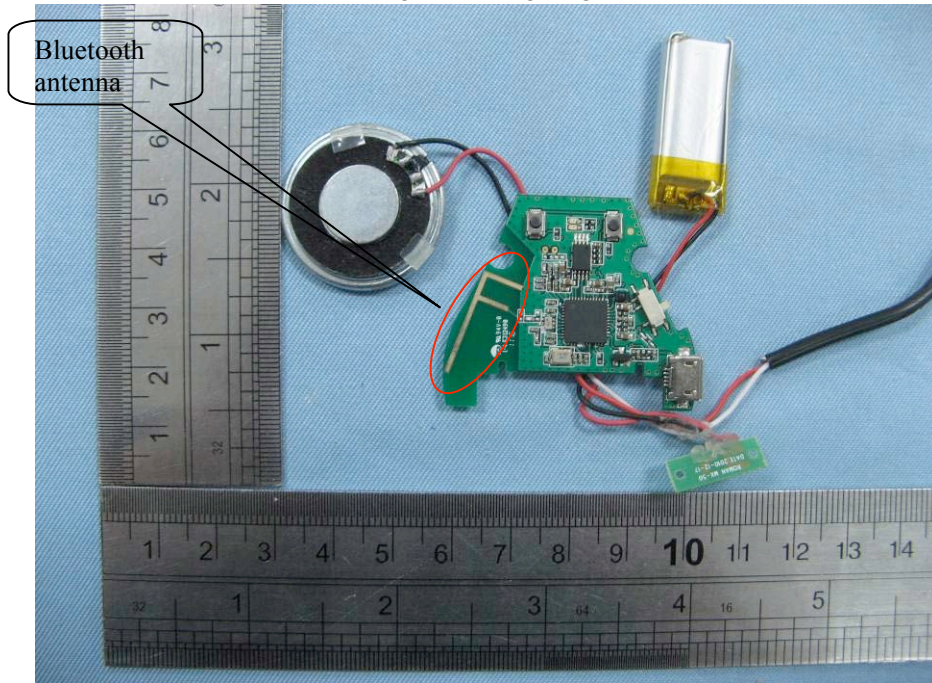

BACK VIEW OF PCB

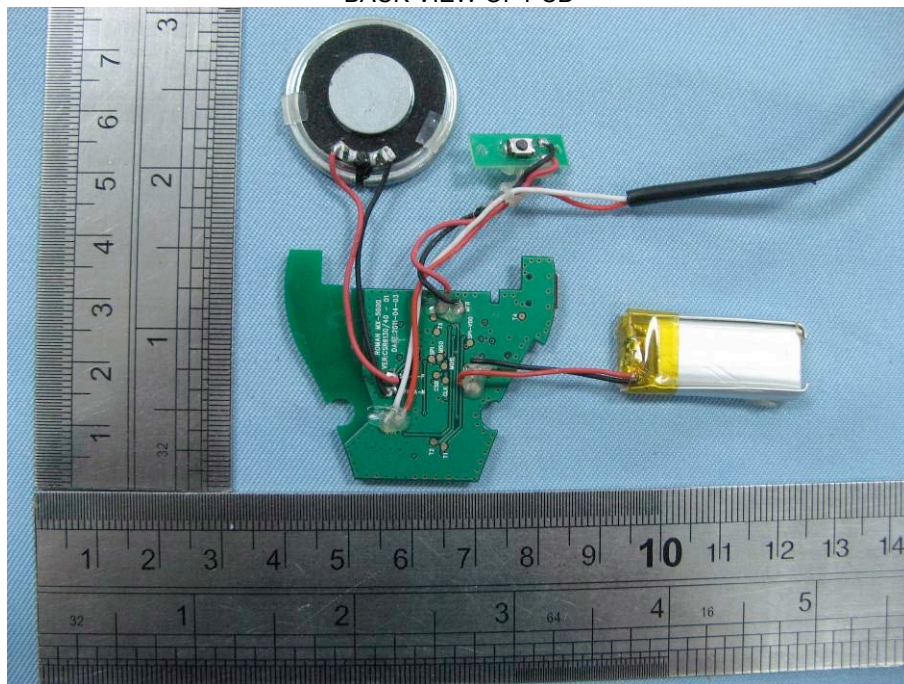

**APPENDIX II
PHOTOGRAPHS OF THE TEST SETUP**

RADIATED EMISSION

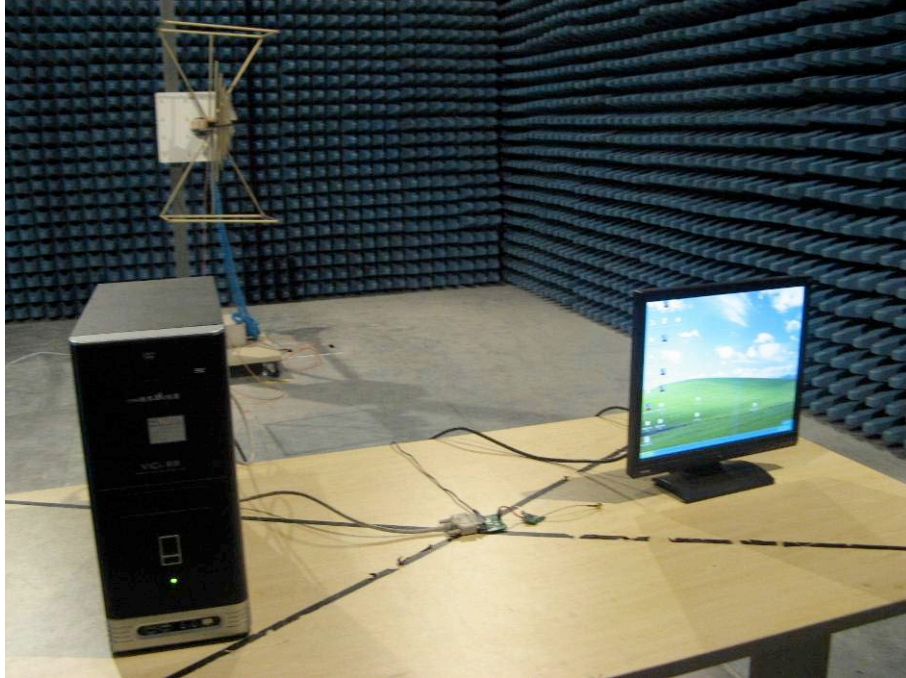

----END OF REPORT----