



FCC RADIO TEST REPORT

Report Reference No. : ATS-2011NT1018003E

Compiled by (+ signature) : Tom Zhang

Approved by (+ signature) : Bovey Yang

Applicant's name : Premier Accessory Group

Address..... : 11-11 44 th Drive, Long Island, New York, United States

Manufacture's Name : Premier Accessory Group

Address..... : 11-11 44 th Drive, Long Island, New York, United States

Test specification:

Standard : FCC Part15.239

Test procedure : ANSI C63.4-2003

Test item description

Product name : Auto FM Transmitter & Charger

FCC ID : ZJVENG-FMT3

Trademark : Energizer

Model and/or type reference : ENG-FMT3

Rating(s) : DC 3.3V

Testing

Date of receipt of test item : 13 Oct. 2011

Date (s) of performance of tests : Oct.15, 2011 ~ Oct.19, 2011

Date of Issue..... : Oct. 19, 2011

Test Result..... : **Pass**



Table of Contents	Page
1 . SUMMARY OF TEST RESULTS	3
1.1 TEST FACILITY	4
1.2 MEASUREMENT UNCERTAINTY	4
2 . GENERAL INFORMATION	5
2.1 GENERAL DESCRIPTION OF EUT	5
2.2 DESCRIPTION OF TEST CONDITIONS	6
2.3 DESCRIPTION OF SUPPORT UNITS	7
2.4 EQUIPMENTS LIST FOR ALL TEST ITEMS	8
3 . TEST RESULT	9
3.1 ANTENNA REQUIREMENT	9
3.1.1 STANDARD REQUIREMENT	9
3.1.2 EUT ANTENNA	9
3.2 CONDUCTED EMISSION MEASUREMENT	10
3.2.1 POWER LINE CONDUCTED EMISSION LIMITS	10
3.2.2 TEST PROCEDURE	11
3.2.3 DEVIATION FROM TEST STANDARD	11
3.2.4 TEST SETUP	11
3.2.5 TEST RESULTS	12
3.3 RADIATED EMISSION MEASUREMENT	13
3.3.1 RADIATED EMISSION LIMITS	13
3.3.2 TEST PROCEDURE	14
3.3.3 DEVIATION FROM TEST STANDARD	14
3.3.4 TEST SETUP	15
3.3.5 TEST RESULTS (BETWEEN 9KHz - 1000 MHz)	16
4 . BANDWIDTH TEST	22
4.1 LIMIT	22
4.2 TEST PROCEDURE	22
4.3 DEVIATION FROM STANDARD	22
4.4 TEST SETUP	22
4.5 TEST RESULTS	23
5 . EUT TEST PHOTO	25



1. SUMMARY OF TEST RESULTS

Test procedures according to the technical standards:

FCC Part15, Subpart C (15.239)			
Standard Section	Test Item	Judgment	Remark
15.207	Conducted Emission	N/A	Note(1)
15.203	Antenna Requirement	Pass	
15.239	Radiated Spurious Emission	Pass	
15.239	Occupied Bandwidth	Pass	

NOTE:

(1) " N/A" denotes test is not applicable in this Test Report.



1.1 TEST FACILITY

NTEK Testing Technology Co., Ltd

Add. : 1/F, Building E, Fenda Science Park, Sanwei Community, Xixiang Street, Bao'an District, Shenzhen P.R. China.

FCC FRN Registration Number:238937; IC Registration Number:9270A-1

1.2 MEASUREMENT UNCERTAINTY

The reported uncertainty of measurement $y \pm U$, where expanded uncertainty U is based on a standard uncertainty multiplied by a coverage factor of $k=2$, providing a level of confidence of approximately **95 %**.

A. Conducted Measurement :

Test Site	Method	Measurement Frequency Range	U , (dB)	NOTE
C01	ANSI	150 KHz ~ 30MHz	1.94	

B. Radiated Measurement :

Test Site	Method	Measurement Frequency Range	Ant. H / V	U , (dB)	NOTE
OS-01	ANSI	30MHz ~ 200MHz	V	2.93	
		30MHz ~ 200MHz	H	2.86	
		200MHz ~ 1,000MHz	V	3.86	
		200MHz ~ 1,000MHz	H	3.94	



2. GENERAL INFORMATION

2.1 GENERAL DESCRIPTION OF EUT

Equipment	Auto FM Transmitter & Charger	
Brand Name	Energizer	
Model Name.	ENG-FMT3	
OEM Brand/Model Name	N/A	
Model Difference	N/A	
Manufacturer	Premier Accessory Group	
Manufacturer Address	11-11 44 th Drive,Long Island, New York,United States	
Product Description	The EUT is a Auto FM Transmitter & Charger	
	Product Type	Low Power Communication Device Transmitter
	Operation Frequency:	88.1-107.9MHz
	Modulation Type:	FM
	Number Of Channel	199CH.
	Antenna Designation:	Printed antenna
	Antenna Gain(Peak)	0 dBi
	Output Power:	46.2 dBuV/m (AV Max.)
Based on the application, features, or specification exhibited in User's Manual, the EUT is considered as an Control Device. More details of EUT technical specification, please refer to the User's Manual.		
Channel List	N/A	
Power Source	DC Voltage supplied from ipod	
Power Rating	DC 3.3V	
Connecting I/O Port(s)	Please refer to the User's Manual	
Products Covered	N/A	

Note:

1. For a more detailed features description, please refer to the manufacturer's specifications or the User's Manual.
2. This device cannot be tuned outside the US band (88.1 - 107.9 MHz)

2.2 DESCRIPTION OF TEST CONDITIONS

(1) EUT was tested in normal configuration (Please See following Block diagram)

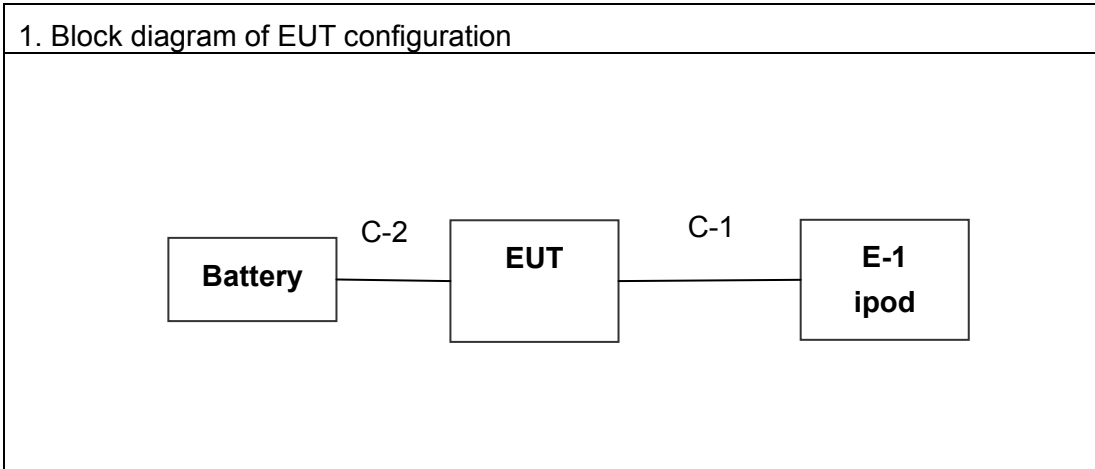

(2) E.U.T. test conditions:

15.31(e) :For intentional radiators, measurements of the variation of the input power or the adiated signal level of the fundamental frequency component of the emission, as appropriate, shall be performed with the supply voltage varied between 85% and 115% ofthe nominal rated supply voltage. For battery operated equipment, theequipment tests shall be performed using a new battery.

(3) Test frequencies:

According to the 15.31(m) Measurements on intentional radiators or receivers, other than TV broadcast receivers, shall be performed and. if required. reported for each band in which the device can be operated with the device operating at the number of fequencies in each band specified in the following table:

Frequency range over which device operates	Number of frequencies	Location in the range of operation
1 MHz or less	1	Middle
1 to 10 MHz	2	1 near top and 1 near bottom
More than 10 MHz	3	1 near top, 1 near middle and 1 near bottom

(4) Frequency range of radiated measurements:

According to the 15.33,The test range will be upto the tenth harmonic of the highest fundamental frequency



2.3 DESCRIPTION OF SUPPORT UNITS

The EUT has been tested as an independent unit together with other necessary accessories or support units. The following support units or accessories were used to form a representative test configuration during the tests.

Item	Equipment	Mfr/Brand	Model/Type No.	FCC ID	Series No.	Note
E-1	ipod	N/A	A1367	VOC	C23DW5T5DCP7	

Item	Shielded Type	Ferrite Core	Length	Note
C-1	NO	NO	20cm	
C-2	NO	NO	25cm	

Note:

- (1) The support equipment was authorized by Declaration of Confirmation.
- (2) For detachable type I/O cable should be specified the length in cm in 『Length』 column.

**2.4 EQUIPMENTS LIST FOR ALL TEST ITEMS****Radiation Test equipment**

Item	Kind of Equipment	Manufacturer	Type No.	Serial No.	Calibrated until
1	Spectrum Analyzer	Agilent	E4407B	160400005	Jul. 06. 2012
2	Test Receiver	R&S	ESPI	101318	Jul. 06. 2012
3	Bilog Antenna	TESEQ	CBL6111D	31216	Jul. 06. 2012
4	50Ω Coaxial Switch	Anritsu	MP59B	6200264416	Jul. 06. 2012
5	Spectrum Analyzer	ADVANTEST	R3132	150900201	Jul. 06. 2012
6	Horn Antenna	EM	EM-AH-10180	2011071402	Jul. 06. 2012
7	Horn Ant	Schwarzbeck	BBHA 9170	9170-181	Jul. 06. 2012
8	Amplifier	EM	EM-30180	060538	Jul. 06. 2012
9	Loop Antenna	ARA	PLA-1030/B	1029	Jul. 06. 2012
10	Power Meter	R&S	NRVS	100696	Jul. 06. 2012

Conduction Test equipment

Item	Kind of Equipment	Manufacturer	Type No.	Serial No.	Calibrated until
1	Test Receiver	R&S	ESCI	101160	Jul. 06. 2012
2	LISN	R&S	ENV216	101313	Jul. 06. 2012
3	LISN	EMCO	3816/2	00042990	Jul. 06. 2012
4	50Ω Coaxial Switch	Anritsu	MP59B	6200264417	Jul. 06. 2012
5	Passive Voltage Probe	R&S	ESH2-Z3	100196	Jul. 06. 2012
6	Absorbing clamp	R&S	MOS-21	100423	Jul. 06. 2012



3. TEST RESULT

3.1 ANTENNA REQUIREMENT

3.1.1 STANDARD REQUIREMENT

15.203 requirement: For intentional device, according to 15.203: an intentional radiator shall be designed to ensure that no antenna other than that furnished by the responsible party shall be used with the device.

3.1.2 EUT ANTENNA

The EUT antenna is integral Antenna. It comply with the standard requirement.



3.2 CONDUCTED EMISSION MEASUREMENT

3.2.1 POWER LINE CONDUCTED EMISSION LIMITS (Frequency Range 150KHz-30MHz)

FREQUENCY (MHz)	Class A (dBuV)		Class B (dBuV)		Standard
	Quasi-peak	Average	Quasi-peak	Average	
0.15 -0.5	79.00	66.00	66 - 56 *	56 - 46 *	CISPR
0.50 -5.0	73.00	60.00	56.00	46.00	CISPR
5.0 -30.0	73.00	60.00	60.00	50.00	CISPR

0.15 -0.5	79.00	66.00	66 - 56 *	56 - 46 *	FCC
0.50 -5.0	73.00	60.00	56.00	46.00	FCC
5.0 -30.0	73.00	60.00	60.00	50.00	FCC

Note:

- (1) The tighter limit applies at the band edges.
- (2) The limit of " * " marked band means the limitation decreases linearly with the logarithm of the frequency in the range.

The following table is the setting of the receiver

Receiver Parameters	Setting
Attenuation	10 dB
Start Frequency	0.15 MHz
Stop Frequency	30 MHz
IF Bandwidth	9 kHz

3.2.2 TEST PROCEDURE

- a. The EUT was placed 0.4 meters from the horizontal ground plane with EUT being connected to the power mains through a line impedance stabilization network (LISN). All other support equipments powered from additional LISN(s). The LISN provide 50 Ohm/ 50uH of coupling impedance for the measuring instrument.
- b. Interconnecting cables that hang closer than 40 cm to the ground plane shall be folded back and forth in the center forming a bundle 30 to 40 cm long.
- c. I/O cables that are not connected to a peripheral shall be bundled in the center. The end of the cable may be terminated, if required, using the correct terminating impedance. The overall length shall not exceed 1 m.
- d. LISN at least 80 cm from nearest part of EUT chassis.
- e. For the actual test configuration, please refer to the related Item –EUT Test Photos.

3.2.3 DEVIATION FROM TEST STANDARD

No deviation

3.2.4 TEST SETUP

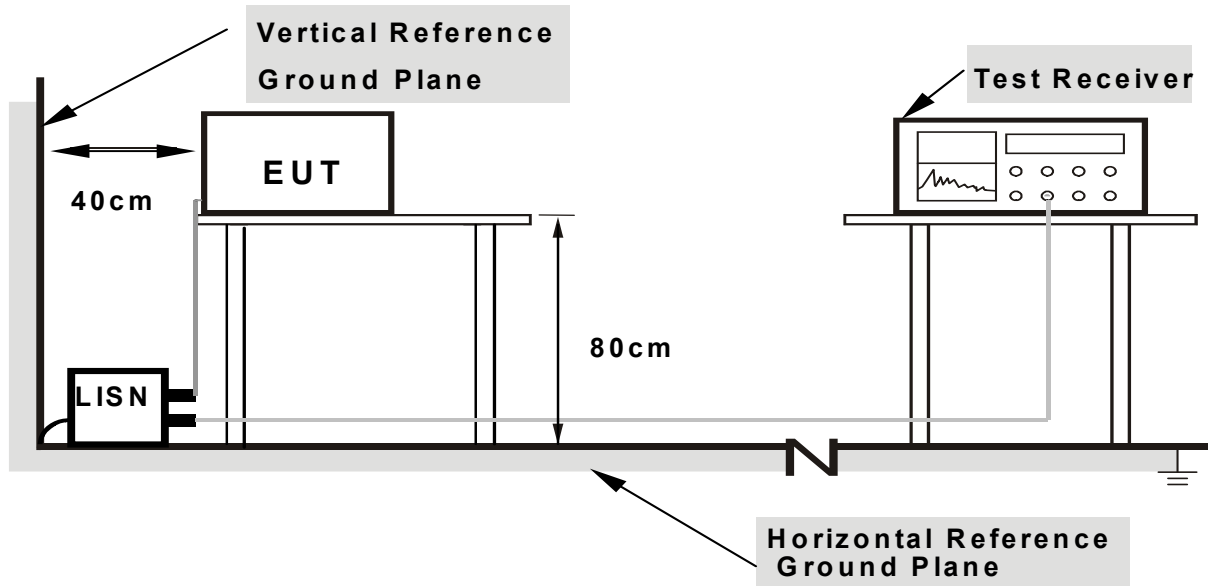

Note: 1.Support units were connected to second LISN.

2.Both of LISNs (AMN) are 80 cm from EUT and at least 80 from other units and other metal planes



3.2.5 TEST RESULTS

EUT :	Auto FM Transmitter & Charger	Model Name :	ENG-FMT3
Temperature :	26 °C	Relative Humidity :	53%
Pressure :	1010 hPa	Test Power :	DC 3.3V
Test Mode :	N/A - denotes test is not applicable in this test report		

Remark

- (1) All readings are QP Mode value unless otherwise stated AVG in column of Note . If the QP Mode Measured value compliance with the QP Limits and lower than AVG Limits, the EUT shall be deemed to meet both QP & AVG Limits and then only QP Mode was measured, but AVG Mode didn't perform . In this case, a “ * ” marked in AVG Mode column of Interference Voltage Measured .
- (2) Measuring frequency range from 150KHz to 30MHz.
- (3) N/A - denotes test is not applicable in this test report



3.3 RADIATED EMISSION MEASUREMENT

3.3.1 RADIATED EMISSION LIMITS (FCC 15.209)

Frequencies (MHz)	Field Strength (microrvolts/meter)	Measurement Distance (meters)
0.009~0.490	2400/F(KHz)	300
0.490~1.705	24000/F(KHz)	30
1.705~30.0	30	30
30~88	100	3
88~216	150	3
216~960	200	3
Above 960	500	3

Note:

- (1) The tighter limit applies at the band edges.
- (2) Emission level (dBuV/m)=20log Emission level (uV/m).

LIMITS OF RADIATED EMISSION MEASUREMENT (FCC 15.231)

Frequency of Emission (MHz)	Field Strength of fundamental (dBµV/m)	
	Peak	Average
88-108	68	48

Notes:

- (1) Fcc part15.239 (b) The field strength of any emissions within the permitted 200 kHz band shall not exceed 250 microvolts/meter at 3 meters. The emission limit in this paragraph is based on measurement instrumentation employing an average detector. The provisions in Section 15.35 for limiting peak emissions apply.

Spectrum Parameter	Setting
Attenuation	Auto
Start Frequency	1000 MHz
Stop Frequency	10th carrier harmonic
RB / VB (emission in restricted band)	1MHz / 1MHz for Peak

Receiver Parameter	Setting
Attenuation	Auto
Start ~ Stop Frequency	9kHz~150kHz / RB 200Hz for QP
Start ~ Stop Frequency	150kHz~30MHz / RB 9kHz for QP
Start ~ Stop Frequency	30MHz~1000MHz / RB 120kHz for QP



3.3.2 TEST PROCEDURE

- a. The measuring distance of at 3 m shall be used for measurements at frequency up to 1GHz. For frequencies above 1GHz, any suitable measuring distance may be used.
- b. The EUT was placed on the top of a rotating table 0.8 meters above the ground at a 3m meter open area test site. The table was rotated 360 degrees to determine the position of the highest radiation.
- c. The height of the equipment or of the substitution antenna shall be 0.8 m; the height of the test antenna shall vary between 1 m to 4 m. Both horizontal and vertical polarizations of the antenna are set to make the measurement. performed pretest to three orthogonal axis.
- d. The initial step in collecting conducted emission data is a spectrum analyzer peak detector mode pre-scanning the measurement frequency range. Significant peaks are then marked and then Quasi Peak detector mode re-measured.
- e. If the Peak Mode measured value compliance with and lower than Quasi Peak Mode Limit, the EUT shall be deemed to meet QP Limits and then no additional QP Mode measurement performed.
- f. For the actual test configuration, please refer to the related Item –EUT Test Photos.

3.3.3 DEVIATION FROM TEST STANDARD

No deviation

3.3.4 TEST SETUP

(A) Radiated Emission Test Set-Up, Frequency Below 1000MHz

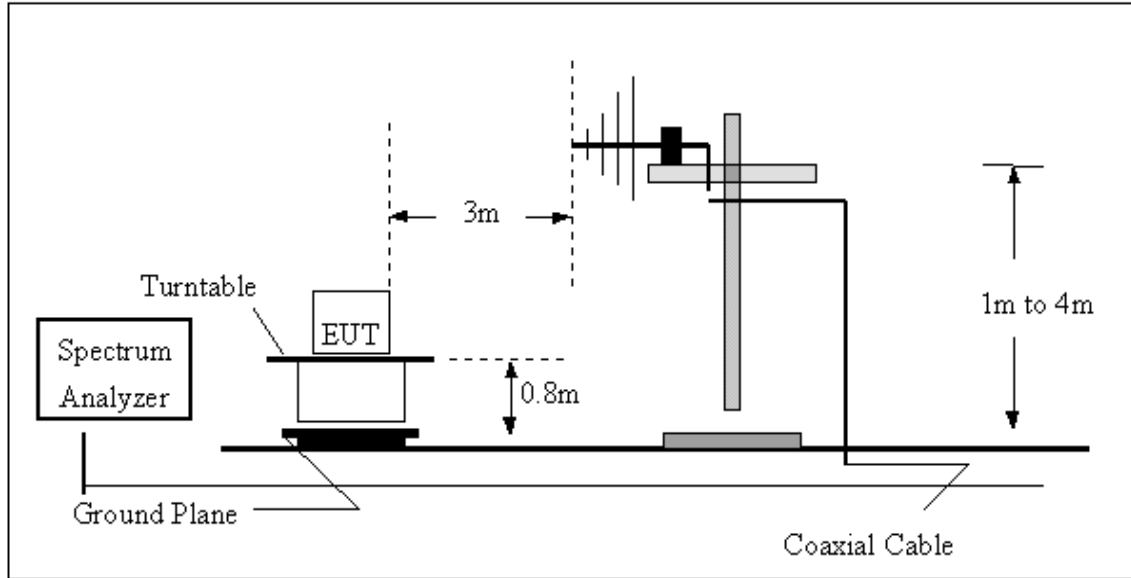

(B) Radiated Emission Test Set-Up Frequency Above 1 GHz

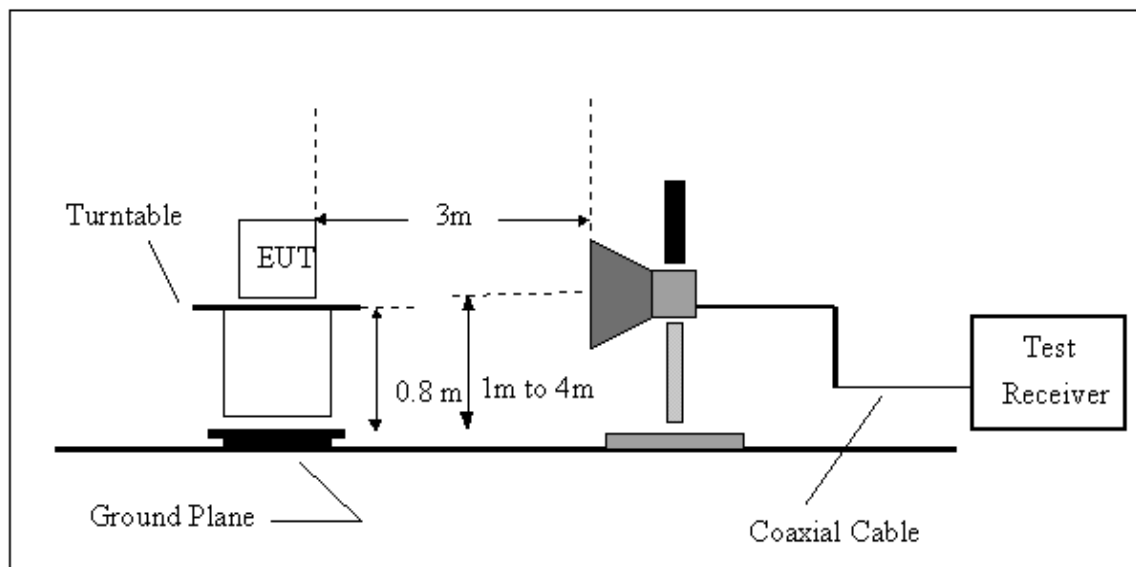

3.3.5 TEST RESULTS (BETWEEN 9KHz – 1000 MHz)

EUT :	Auto FM Transmitter & Charger	Model Name :	ENG-FMT3
Temperature :	24 °C	Relative Humidity :	54%
Pressure :	1010 hPa	Test Date :	2011-10-16
Test Mode :	88.1MHz	Polarization :	Horizontal
Test Power :	DC 3.3V		

Frequency (MHz)	Meter Reading (dBµV)	Factor (dB)	Emission Level (dBµV/m)	Limits (dBµV/m)	Margin (dB)	Detector Type
88.1328	47.3	9.08	56.38	68	-11.62	peak
88.1328	36.51	9.08	45.59	48	-2.41	AVG
177.5091	26.32	9.68	36	43.5	-7.5	QP
261.0582	21.97	14.23	36.2	46	-9.8	QP
354.1831	26.2	15.44	41.64	46	-4.36	QP
706.6998	19.3	22.38	41.68	46	-4.32	QP

Remark:

1. Factor = Antenna Factor + Cable Loss – Pre-amplifier.

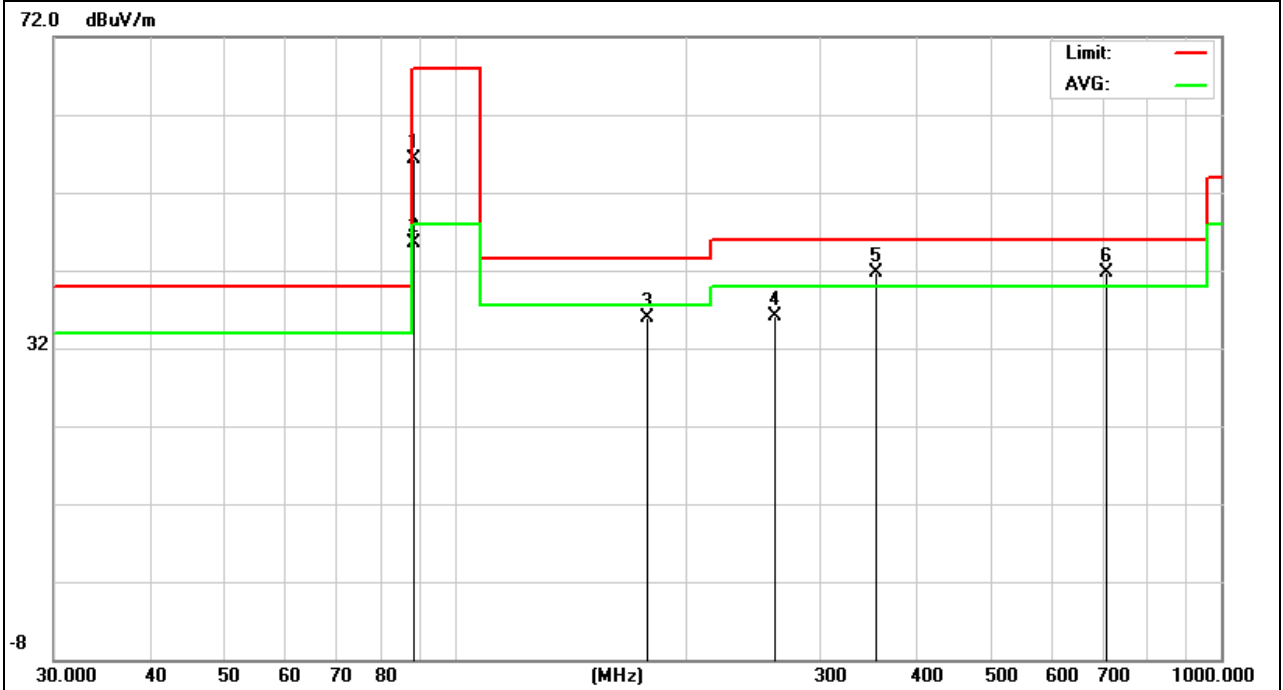



EUT :	Auto FM Transmitter & Charger	Model Name :	ENG-FMT3
Temperature :	24 °C	Relative Humidity :	54%
Pressure :	1010 hPa	Test Date :	2011-10-16
Test Mode :	88.1MHz	Polarization :	Vertical
Test Power :	DC 3.3V		

Frequency (MHz)	Meter Reading (dBµV)	Factor (dB)	Emission Level (dBµV/m)	Limits (dBµV/m)	Margin (dB)	Detector Type
88.1327	45.18	9.08	54.26	68	-13.74	peak
88.1327	35.11	9.08	44.19	48	-3.81	AVG
176.8875	25.12	9.68	34.8	43.5	-8.7	QP
261.9753	23.05	14.15	37.2	46	-8.8	QP
350.4768	20.22	15.38	35.6	46	-10.4	QP
622.8899	14.47	22.03	36.5	46	-9.5	QP

Remark:

1. Factor = Antenna Factor + Cable Loss – Pre-amplifier.

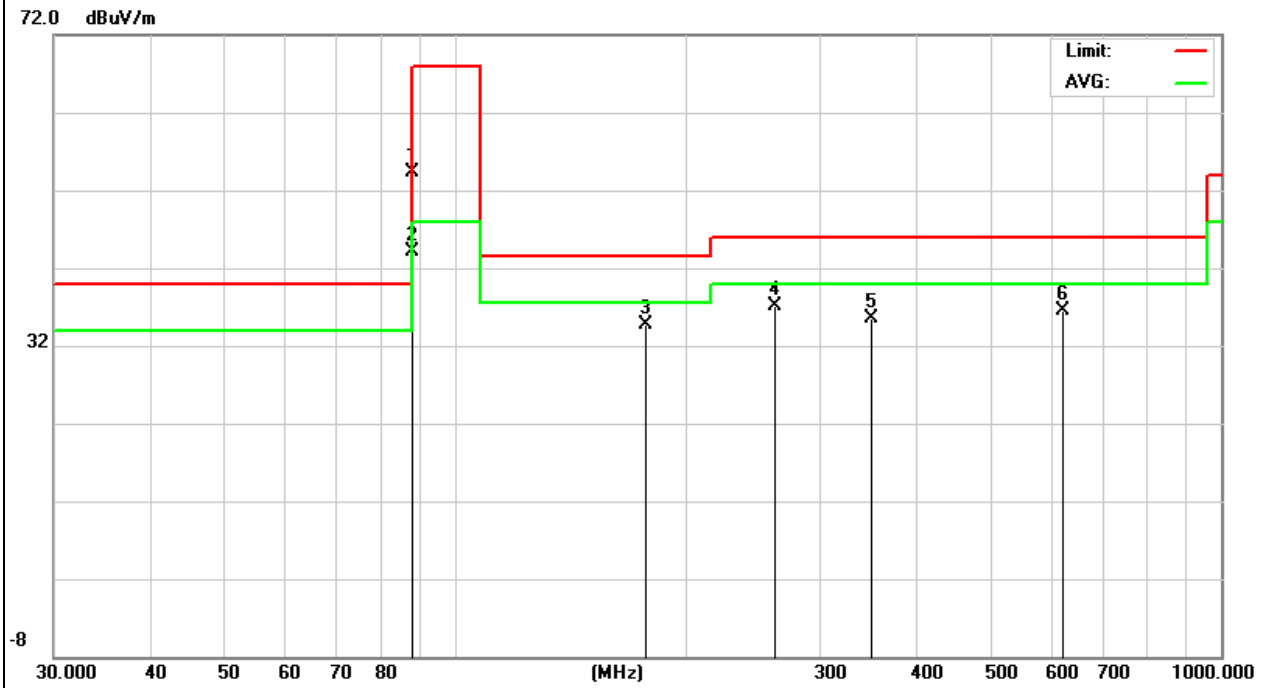



EUT :	Auto FM Transmitter & Charger	Model Name :	ENG-FMT3
Temperature :	24 °C	Relative Humidity :	54%
Pressure :	1010 hPa	Test Date :	2011-10-16
Test Mode :	98.1MHz	Polarization :	Horizontal
Test Power :	DC 3.3V		

Frequency (MHz)	Meter Reading (dBµV)	Factor (dB)	Emission Level (dBµV/m)	Limits (dBµV/m)	Margin (dB)	Detector Type
98.1419	45.32	10.31	55.63	68	-12.37	peak
98.1419	33.39	10.31	43.7	48	-4.3	AVG
197.1999	29.71	8.69	38.4	43.5	-5.1	QP
292.0581	18.66	14.12	32.78	46	-13.22	QP
387.992	19.72	16.78	36.5	46	-9.5	QP
691.9867	14.65	22.05	36.7	46	-9.3	QP

Remark:

1. Factor = Antenna Factor + Cable Loss – Pre-amplifier.

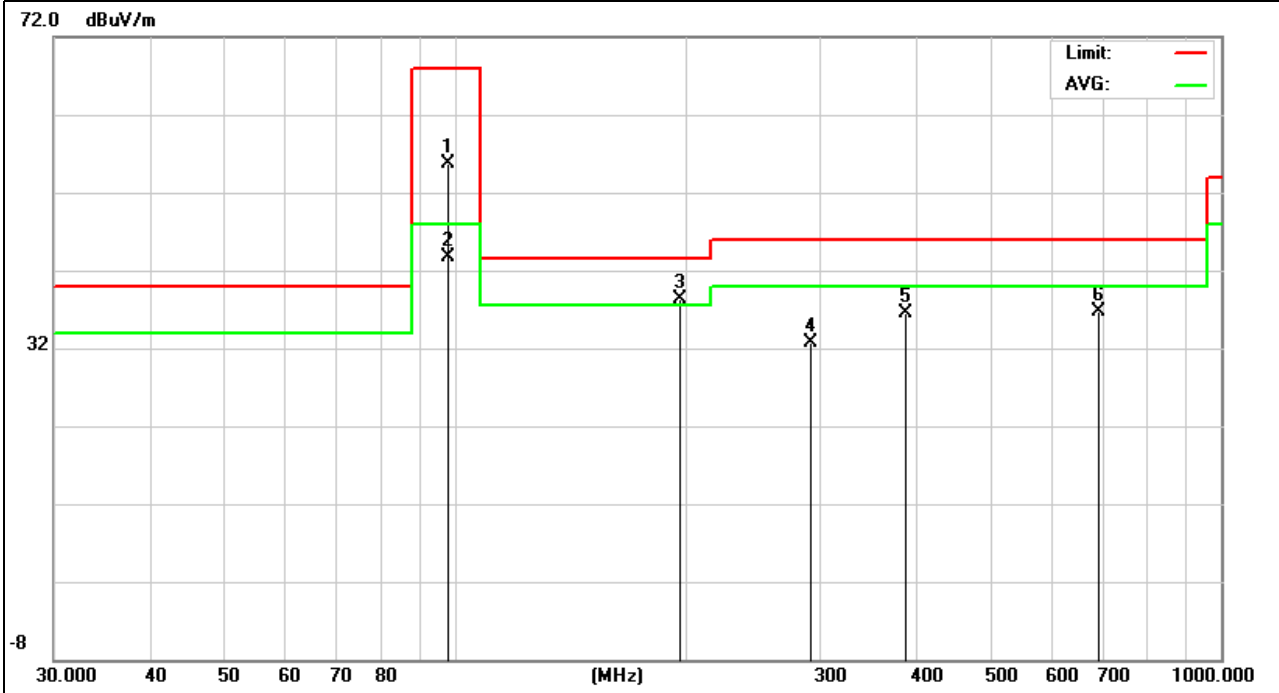



EUT :	Auto FM Transmitter & Charger	Model Name :	ENG-FMT3
Temperature :	24 °C	Relative Humidity :	54%
Pressure :	1010 hPa	Test Date :	2011-10-16
Test Mode :	98.1MHz	Polarization :	Vertical
Test Power :	DC 3.3V		

Frequency (MHz)	Meter Reading (dBµV)	Factor (dB)	Emission Level (dBµV/m)	Limits (dBµV/m)	Margin (dB)	Detector Type
98.1419	47.34	10.31	57.65	68	-10.35	peak
98.1419	35.18	10.31	45.49	48	-2.51	AVG
195.1365	28.52	8.68	37.2	43.5	-6.3	QP
293.0842	22.69	14.21	36.9	46	-9.1	QP
389.3548	19.37	16.83	36.2	46	-9.8	QP
582.7423	15.85	20.85	36.7	46	-9.3	QP

Remark:

1. Factor = Antenna Factor + Cable Loss – Pre-amplifier.

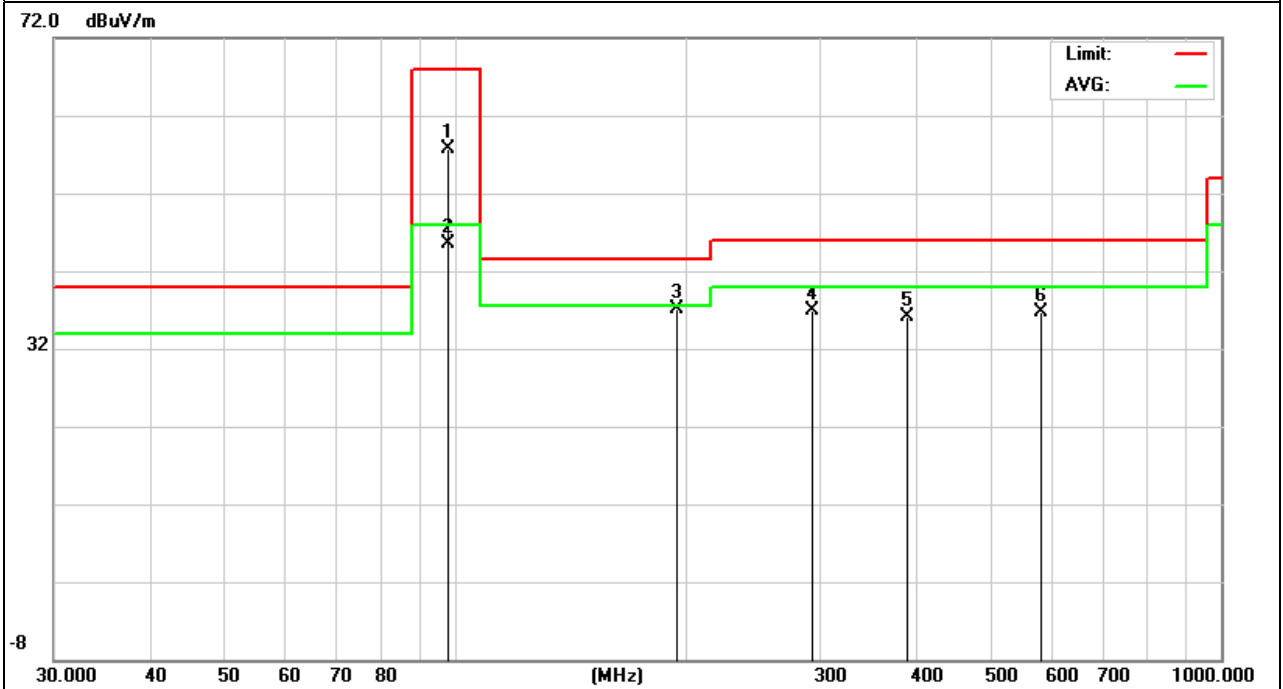



EUT :	Auto FM Transmitter & Charger	Model Name :	ENG-FMT3
Temperature :	24 °C	Relative Humidity :	54%
Pressure :	1010 hPa	Test Date :	2011-10-16
Test Mode :	107.9MHz	Polarization :	Horizontal
Test Power :	DC 3.3V		

Frequency (MHz)	Meter Reading (dBµV)	Factor (dB)	Emission Level (dBµV/m)	Limits (dBµV/m)	Margin (dB)	Detector Type
107.8876	42.06	11.21	53.27	68	-14.73	peak
107.8876	34.99	11.21	46.2	48	-1.8	AVG
165.4866	16.06	10.41	26.47	43.5	-17.03	QP
321.0607	24.98	14.75	39.73	46	-6.27	QP
429.5228	20.49	17.71	38.2	46	-7.8	QP
654.2318	18.34	21.76	40.1	46	-5.9	QP

Remark:

1. Factor = Antenna Factor + Cable Loss – Pre-amplifier.

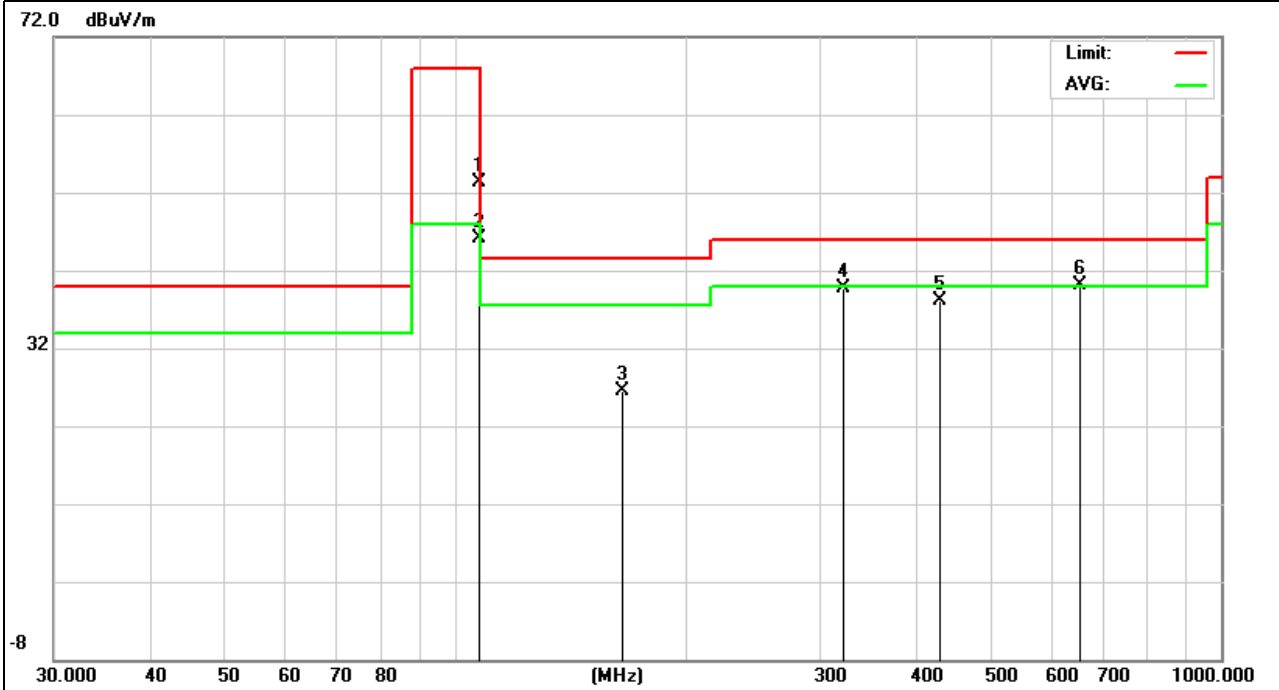



EUT :	Auto FM Transmitter & Charger	Model Name :	ENG-FMT3
Temperature :	24 °C	Relative Humidity :	54%
Pressure :	1010 hPa	Test Date :	2011-10-16
Test Mode :	107.9MHz	Polarization :	Vertical
Test Power :	DC 3.3V		

Frequency (MHz)	Meter Reading (dBµV)	Factor (dB)	Emission Level (dBµV/m)	Limits (dBµV/m)	Margin (dB)	Detector Type
107.912	40.39	11.21	51.6	68	-16.4	peak
107.912	34.02	11.21	45.23	48	-2.77	AVG
216.7828	24.11	9.59	33.7	46	-12.3	QP
324.456	17.47	14.83	32.3	46	-13.7	QP
533.832	13.11	21.99	35.1	46	-10.9	QP
747.4825	13.12	24.28	37.4	46	-8.6	QP

Remark:

1. Factor = Antenna Factor + Cable Loss – Pre-amplifier.

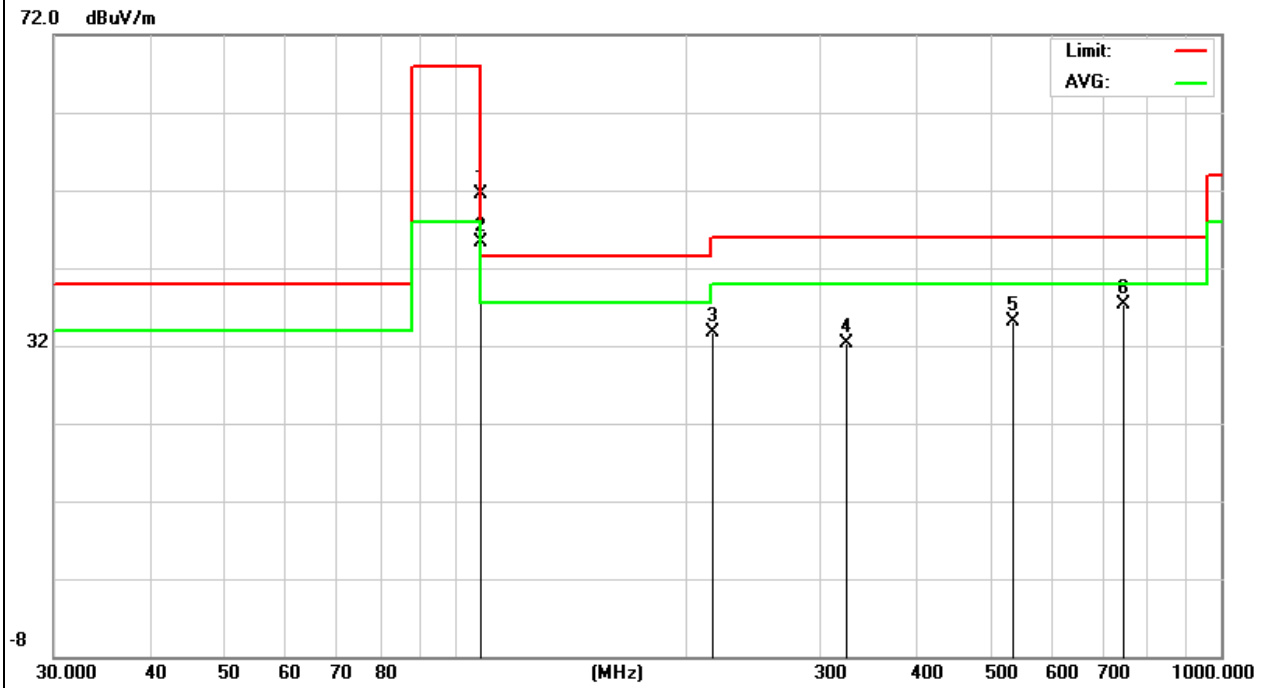

4. BANDWIDTH TEST

4.1 LIMIT

(a) Emissions from the intentional radiator shall be confined within a band 200 kHz wide centered on the operating frequency. The 200kHz band shall lie wholly within the frequency range of 88-108 MHz

4.2 TEST PROCEDURE

- a. The EUT was directly connected to the spectrum analyzer and antenna output port as show in the block diagram below,
- b. Spectrum Setting : RBW= 10KHz, VBW \geq RBW, Sweep time = Auto.

4.3 DEVIATION FROM STANDARD

No deviation.

4.4 TEST SETUP





4.5 TEST RESULTS

EUT :	Auto FM Transmitter & Charger	Model Name :	ENG-FMT3
Temperature :	26 °C	Relative Humidity :	53%
Pressure :	1020 hPa	Test Power :	DC 3.3V
Test Mode :	TX		

Test Channel	Frequency (MHz)	20 dBc Bandwidth (kHz)	Limit (kHz)
CH01	88.1	77.1	200
CH101	98.1	83.1	200
CH199	107.9	72.6	200

The Lowest Channel:88.1MHz

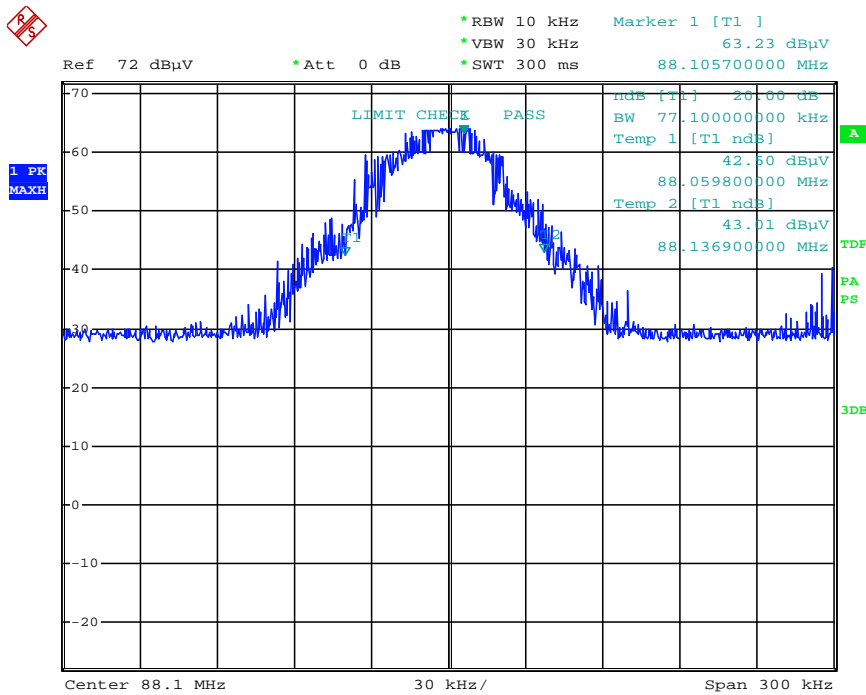

Date: 19.OCT.2011 12:17:18



The Middle Channel:98.1MHz

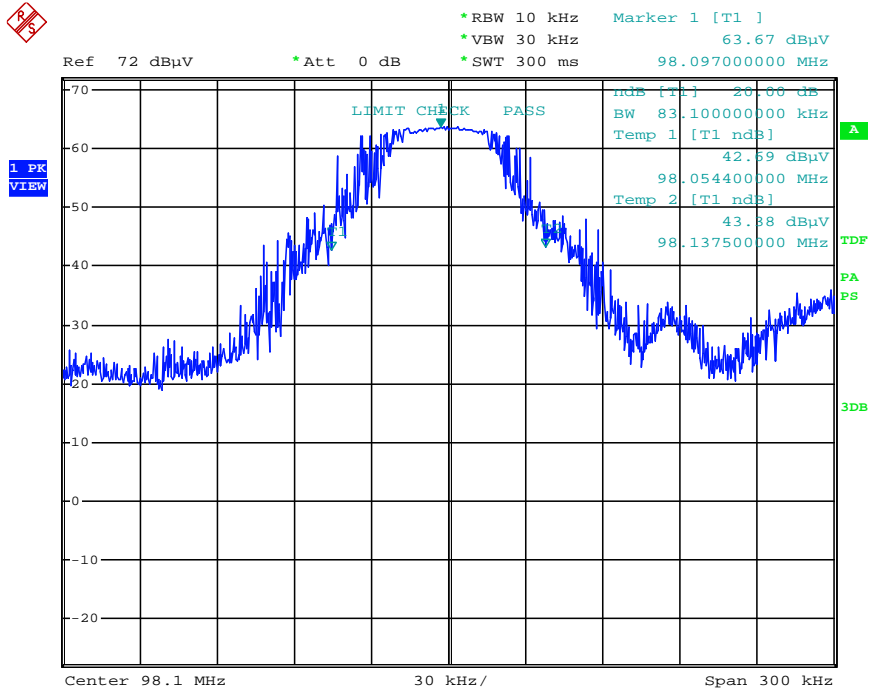

Date: 19.OCT.2011 12:24:03

The Highest Channel:107.9MHz

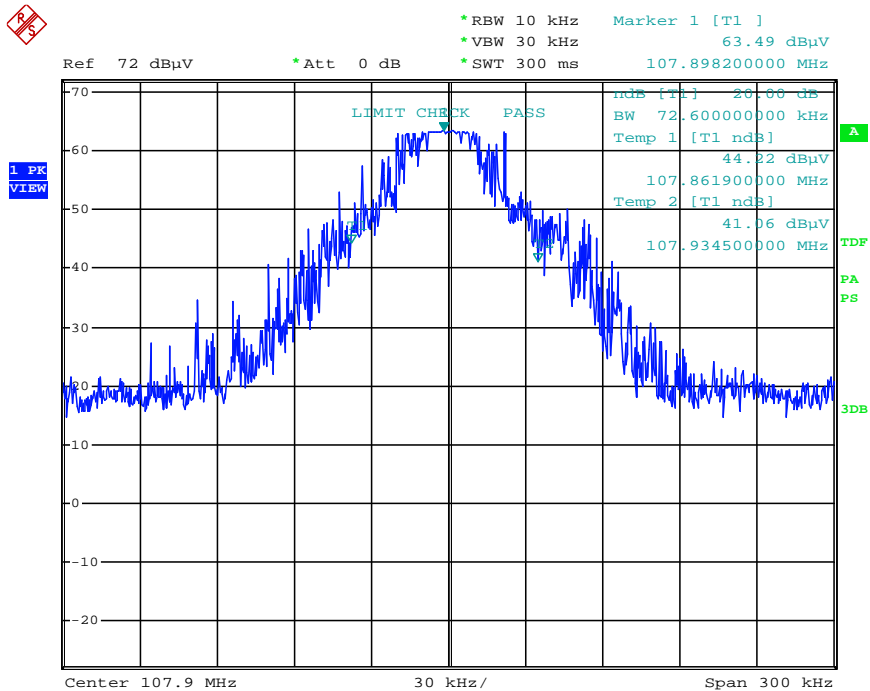

Date: 19.OCT.2011 12:25:00