



FCC PART 15 SUBPART C TEST REPORT

Part 15.247

Report Reference No.....: **CTL1411252833-WF**

Compiled by

(position+printed name+signature) .: File administrators Jacky Chen

Name of the organization performing the tests

Test Engineer Tracy Qi

(position+printed name+signature) .:

Approved by

(position+printed name+signature) .: Manager Tracy Qi

Date of issue.....: Dec. 09, 2014

Test Laboratory Name: **Shenzhen CTL Testing Technology Co., Ltd.**

Address: Floor 1-A, Baisha Technology Park, No.3011, Shahexi Road, Nanshan District, Shenzhen, China 518055

Applicant's name.....: **Shenzhen Geniatech INC., LTD**

Address: 18th F, GDC Building, No. 9 Gaoxin Middle 3rd Rd., Nanshan District, Shenzhen, China

Test specification:

Standard: FCC Part 15.247: Operation within the bands 902–928 MHz, 2400–2483.5 MHz, and 5725–5850 MHz.

TRF Originator.....: Shenzhen CTL Testing Technology Co., Ltd.

Master TRF.....: Dated 2011-01

Shenzhen CTL Testing Technology Co., Ltd. All rights reserved.

This publication may be reproduced in whole or in part for non-commercial purposes as long as the Shenzhen CTL Testing Technology Co., Ltd. is acknowledged as copyright owner and source of the material. Shenzhen CTL Testing Technology Co., Ltd. takes no responsibility for and will not assume liability for damages resulting from the reader's interpretation of the reproduced material due to its placement and context.

Test item description: Enjoy TV

FCC ID.....: ZJU015N116D

Trade Mark: N/A

Model/Type reference: APC380, APC361, APC360EP, ATV580, ATV585, ATV360, ATV360BC, ATV360CE, ATV360CD, ATV360DE, ATV370, ATV485, ATV390, ATV520E, ATV520V, ATV520B

Modulation: 802.11b DSSS, 802.11g/n: OFDM

Work Frequency Range: 802.11b/g/n(20MHz): 2412~2462MHz

Antenna Type: External

Antenna Gain.....: 0.5dBi

Result: **Positive**

TEST REPORT

Test Report No. :	CTL1411252833-WF	Dec. 09, 2014
		Date of issue

Equipment under Test : Enjoy TV

Model /Type : APC380

Listed Modes : APC361, APC360EP, ATV580, ATV585, ATV360, ATV360BC, ATV360CE, ATV360CD, ATV360DE, ATV370, ATV485, ATV390, ATV520E, ATV520V, ATV520B

Difference Description : Only the color and model's name is different

Applicant : **Shenzhen Geniatech INC., LTD**

Address : 18th F, GDC Building, No. 9 Gaoxin Middle 3rd Rd., Nanshan District, Shenzhen, China

Manufacturer : **Shenzhen Geniatech INC., LTD**

Address : 18th F, GDC Building, No. 9 Gaoxin Middle 3rd Rd., Nanshan District, Shenzhen, China

Test Result according to the standards on page 4:

Positive

The test report merely corresponds to the test sample.
It is not permitted to copy extracts of these test result without the written permission of the test laboratory.

Contents

1.	<u>TEST STANDARDS</u>	4
2.	<u>SUMMARY</u>	5
2.1.	General Remarks	5
2.2.	Equipment Under Test	5
2.3.	Short description of the Equipment under Test (EUT)	5
2.4.	EUT operation mode	6
2.5.	EUT configuration	6
2.6.	NOTE	6
2.7.	Related Submittal(s) / Grant (s)	6
2.8.	Modifications	6
3.	<u>TEST ENVIRONMENT</u>	6
3.1.	Address of the test laboratory	7
3.2.	Test Facility	7
3.3.	Environmental conditions	7
3.4.	Configuration of Tested System	7
3.5.	Statement of the measurement uncertainty	7
3.6.	Equipments Used during the Test	8
3.7.	Summary of Test Result	9
4.	<u>TEST CONDITIONS AND RESULTS</u>	10
4.1.	Conducted Emissions Test	10
4.2.	Radiated Emission Test	13
4.3.	6dB Bandwidth Measurement	20
4.4.	Maximum Peak Output Power	27
4.5.	Band Edge Measurement	29
4.6.	Power Spectral Density Measurement	54
4.7.	Spurious RF Conducted Emission	61
4.8.	Antenna Requirement	71
5.	<u>TEST SETUP PHOTOS OF THE EUT</u>	72
6.	<u>EXTERNAL AND INTERNAL PHOTOS OF THE EUT</u>	74

1. TEST STANDARDS

The tests were performed according to following standards:

[FCC Part 15.247](#): Frequency Hopping, Direct Spread Spectrum and Hybrid Systems that are in operation within the bands of 902-928 MHz, 2400-2483.5 MHz, and 5725-5850 MHz.

[ANSI C63.10-2009](#): American National Standard for Testing Unlicensed Wireless Devices.

[ANSI C63.4-2009](#)

[KDB Publication No. 558074 D01 v03r02 Guidance on Measurements for Digital Transmission Systems](#)



2. SUMMARY

2.1. General Remarks

Date of receipt of test sample	:	Nov. 25, 2014
Testing commenced on	:	Nov. 25, 2014
Testing concluded on	:	Dec. 09, 2014

2.2. Equipment Under Test

Power supply system utilised

Power supply voltage	:	<input checked="" type="radio"/> 120V / 60 Hz	<input type="radio"/> 115V / 60Hz
		<input type="radio"/> 12 V DC	<input type="radio"/> 24 V DC
		<input type="radio"/> Other (specified in blank below)	

Description of the test mode

IEEE 802.11b/g/n(HT20): Thirteen channels are provided to the EUT, but only eleventh channels used for USA.

Channel	Frequency(MHz)	Channel	Frequency(MHz)
1	2412	8	2447
2	2417	9	2452
3	2422	10	2457
4	2427	11	2462
5	2432		
6	2437		
7	2442		

2.3. Short description of the Equipment under Test (EUT)

Enjoy TV, support 802.11b/g/n.

For more details, refer to the user's manual of the EUT.

Serial number: Prototype

2.4. EUT operation mode

Test Mode:

1. The EUT has been tested under normal operating condition.
2. Test program used to control the EUT for staying in continuous transmitting and receiving mode is programmed. Channel low (2412MHz), mid (2437MHz) and high (2462MHz) for 802.11b/g/n(HT20) with highest data rate are chosen for full testing.
3. Test Mode:

Test Mode(TM)	Description	Remark
1	Transmitting	802.11 b
2	Transmitting	802.11 g
3	Transmitting	802.11 n HT20

2.5. EUT configuration

The following peripheral devices and interface cables were connected during the measurement:

- supplied by the manufacturer

- supplied by the lab

AC adapter

Manufacturer : SHENZHEN FUJIA APPLIANCE CO., LTD

Model No. : FJ-SW0502000E

2.6. NOTE

1. The EUT is a 7.85" Enjoy TV, The functions of the EUT listed as below:

	Test Standards	Reference Report
WLAN 802.11b/g, 802.11n	FCC Part 15 Subpart C (Section15.247) FCC Per 47 CFR 2.1091(b)	CTL1411252833-WF

2. The frequency bands used in this EUT are listed as follows:

Frequency Band(MHz)	2400-2483.5	5150-5350	5470-5725	5725-5850
802.11b	√	—	—	—
802.11g	√	—	—	—
802.11n(20MHz)	√	—	—	—

3. The EUT incorporates a SISO function, Physically, the EUT provides two completed transmitter and two completed receivers.

Modulation Mode	TX Function
802.11b	1TX
802.11g	1TX
802.11n (20MHz)	1TX

2.7. Related Submittal(s) / Grant (s)

This submittal(s) (test report) is intended for FCCID: ZJU015N116D filing to comply with of the FCC part15.247 Rules.

2.8. Modifications

No modifications were implemented to meet testing criteria.

3. TEST ENVIRONMENT

3.1. Address of the test laboratory

Shenzhen CTL Testing Technology Co., Ltd.
 Floor 1-A, Baisha Technology Park, No.3011, Shahexi Road, Nanshan District, Shenzhen, China 518055

The sites are constructed in conformance with the requirements of ANSI C6230, ANSI C63.4 (2009) and CISPR Publication 22.

3.2. Test Facility

The test facility is recognized, certified, or accredited by the following organizations:

IC Registration No.: 9618B

The 3m alternate test site of Shenzhen CTL Testing Technology Co., Ltd. EMC Laboratory has been registered by Certification and Engineer Bureau of Industry Canada for the performance of with Registration No.: 9618B on November 13, 2013.

FCC-Registration No.: 970318

Shenzhen CTL Testing Technology Co., Ltd. EMC Laboratory has been registered and fully described in a report filed with the (FCC) Federal Communications Commission. The acceptance letter from the FCC is maintained in our files. Registration 970318, December 19, 2013.

3.3. Environmental conditions

During the measurement the environmental conditions were within the listed ranges:

Temperature:	15-35 ° C
Humidity:	30-60 %
Atmospheric pressure:	950-1050mbar

3.4. Configuration of Tested System

Fig. 2-1 Configuration of Tested System

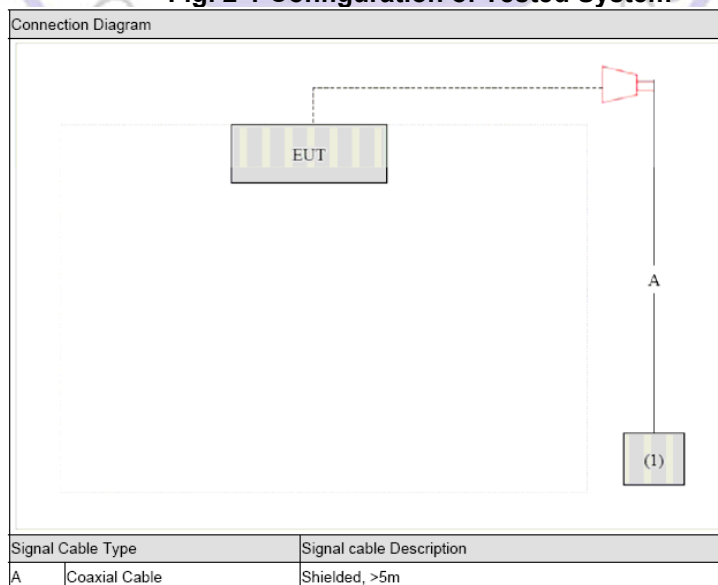

3.5. Statement of the measurement uncertainty

The data and results referenced in this document are true and accurate. The reader is cautioned that there may be errors within the calibration limits of the equipment and facilities. The measurement uncertainty was calculated for all measurements listed in this test report acc. to CISPR 16 - 4 „Specification for radio disturbance and immunity measuring apparatus and methods – Part 4: Uncertainty in EMC Measurements“ and is documented in the Shenzhen

CTL Testing Technology Co., Ltd. quality system acc. to DIN EN ISO/IEC 17025. Furthermore, component and process variability of devices similar to that tested may result in additional deviation. The manufacturer has the sole responsibility of continued compliance of the device.

Hereafter the best measurement capability for CTL laboratory is reported:

Test	Range	Measurement Uncertainty	Notes
Radiated Emission	30~1000MHz	4.10dB	(1)
Radiated Emission	1~12.75GHz	4.32dB	(1)
Radiated Emission	12.75GHz-25 GHz	4.68dB	(1)
Conducted Disturbance	0.15~30MHz	3.20dB	(1)

(1) This uncertainty represents an expanded uncertainty expressed at approximately the 95% confidence level using a coverage factor of k=2.

3.6. Equipments Used during the Test

Test Equipment	Manufacturer	Model No.	Serial No.	Calibration Date	Calibration Due Date
Bilog Antenna	Sunol Sciences Corp.	JB1	A061713	2014/07/12	2015/07/11
EMI Test Receiver	R&S	ESCI	103710	2014/07/10	2015/07/09
Spectrum Analyzer	Agilent	E4407B	MY45108355	2014/07/06	2015/07/05
Controller	EM Electronics	Controller EM 1000	N/A	2014/07/06	2015/07/05
Horn Antenna	Sunol Sciences Corp.	DRH-118	A062013	2014/07/12	2015/07/11
Horn Antenna	SCHWARZBECK	BBHA9170	1562	2014/07/12	2015/07/11
Active Loop Antenna	SCHWARZBECK	FMZB1519	1519-037	2014/07/12	2015/07/11
LISN	R&S	ENV216	101316	2014/07/10	2015/07/09
LISN	SCHWARZBECK	NSLK8127	8127687	2014/07/10	2015/07/09
Microwave Preamplifier	HP	8349B	3155A00882	2014/07/10	2015/07/09
Amplifier	HP	8447D	3113A07663	2014/07/10	2015/07/09
Transient Limiter	Com-Power	LIT-153	532226	2014/07/10	2015/07/09
Radio Communication Tester	R&S	CMU200	3655A03522	2014/07/06	2015/07/05
Temperature/Humidity Meter	zhicheng	ZC1-2	22522	2014/07/10	2015/07/09
SIGNAL GENERATOR	HP	8647A	3200A00852	2014/07/10	2015/07/09
Wideband Peak Power Meter	Anritsu	ML2495A	220.23.35	2014/07/06	2015/07/05
Climate Chamber	ESPEC	EL-10KA	A20120523	2014/07/06	2015/07/05
High-Pass Filter	K&L	9SH10-2700/X12750-O/O	/	2014/07/06	2015/07/05
High-Pass Filter	K&L	41H10-1375/U12750-O/O	/	2014/07/06	2015/07/05

3.7. Summary of Test Result

FCC PART 15		
FCC Part 15.207	AC Power Conducted Emission	PASS
FCC Part 15.247(a)(2)	6dB Bandwidth	PASS
FCC Part 15.247(d)	Spurious RF Conducted Emission	PASS
FCC Part 15.247(b)	Maximum Peak Output Power	PASS
FCC Part 15.247(e)	Power Spectral Density	PASS
FCC Part 15.109/ 15.205/ 15.209	Radiated Emissions	PASS
FCC Part 15.247(d)	Band Edge Compliance of RF Emission	PASS
FCC Part 15.203/15.247 (b)	Antenna Requirement	PASS

Remark: The measurement uncertainty is not included in the test result.

Preliminary tests were performed in different data rate to find the worst radiated emission. The data rate shown in the table below is the worst-case rate with respect to the specific test item. Investigation has been done on all the possible configurations for searching the worst cases. The following table is a list of the test modes shown in this test report.

Test Items	Mode	Data Rate	Channel
AC Power Conducted Emission	Normal Link	11 Mbps	1
Maximum Peak Conducted Output Power Power Spectral Density 6dB Bandwidth Spurious RF conducted emission	11b/DSSS	11 Mbps	1/6/11
	11g/OFDM	54 Mbps	1/6/11
	11n(20MHz)/OFDM	65Mbps	1/6/11
Radiated Emission 30MHz~1GHz	11b/DSSS	11 Mbps	1/6/11
	11g/OFDM	54 Mbps	1/6/11
	11n(20MHz)/OFDM	65Mbps	1/6/11
Radiated Emission 1GHz~10th Harmonic	11b/DSSS	11 Mbps	1/6/11
	11g/OFDM	54 Mbps	1/6/11
	11n(20MHz)/OFDM	65Mbps	1/6/11
Band Edge Compliance of RF Emission	11b/DSSS	11 Mbps	1/11
	11g/OFDM	54 Mbps	1/11
	11n(20MHz)/OFDM	65Mbps	1/11

Note1: According exploratory test, EUT will have maximum output power in those data rate, so those data rate were used for all test.

4. TEST CONDITIONS AND RESULTS

4.1. Conducted Emissions Test

TEST CONFIGURATION

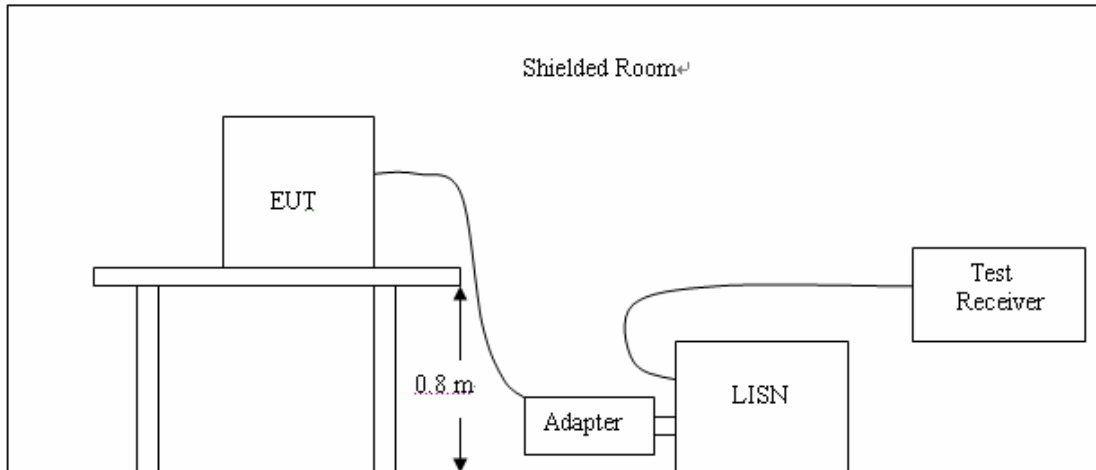

TEST PROCEDURE

For unintentional device, according to § 15.107(a) Line Conducted Emission Limits is as following:

Frequency (MHz)	Maximum RF Line Voltage (dB μ v)			
	CLASS A		CLASS B	
	Q.P.	Ave.	Q.P.	Ave.
0.15 - 0.50	79	66	66-56*	56-46*
0.50 - 5.00	73	60	56	46
5.00 - 30.0	73	60	60	50

* Decreasing linearly with the logarithm of the frequency

For intentional device, according to §15.207(a) Line Conducted Emission Limit is same as above table.

1. Please follow the guidelines in ANSI C63.4-2009.
2. The EUT was placed 0.4 meter from the conducting wall of the shielding room was kept at least 80 centimeters from any other grounded conducting surface.
3. Connect EUT to the power mains through a line impedance stabilization network (LISN).
4. All the support units are connecting to the other LISN.
5. The LISN provides 50 ohm coupling impedance for the measuring instrument.
6. The FCC states that a 50 ohm, 50 microhenry LISN should be used.
7. Both sides of AC line were checked for maximum conducted interference.
8. The frequency range from 150 kHz to 30 MHz was searched.
9. Set the test-receiver system to Peak Detect Function and specified bandwidth with Maximum Hold Mode.

The RBW/VBW for 150KHz to 30MHz: 9KHz

TEST RESULTS

SCAN TABLE: "Voltage (9K-30M)FIN"

Short Description: 150K-30M Voltage

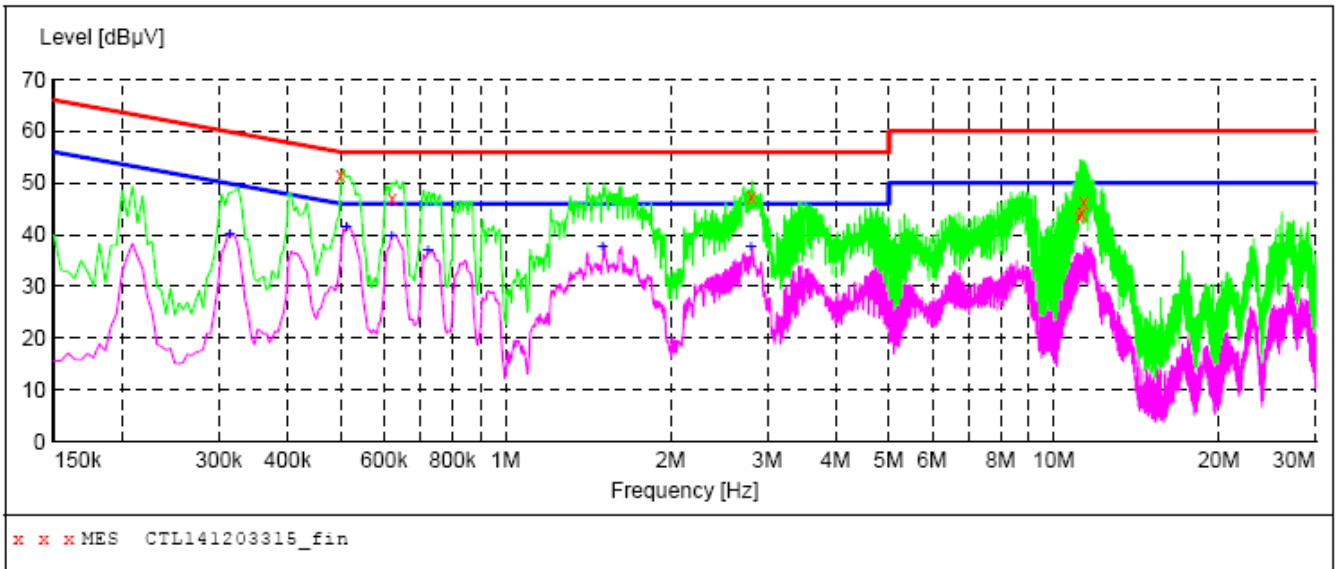

MEASUREMENT RESULT: "CTL141203315_fin"

12/3/2014 11:26AM

Frequency MHz	Level dBµV	Transd dB	Limit dBµV	Margin dB	Detector	Line	PE
0.500000	51.40	10.2	56	4.6	QP	N	GND
0.620000	47.00	10.2	56	9.0	QP	N	GND
2.804000	47.30	10.4	56	8.7	QP	N	GND
11.108000	43.60	10.6	60	16.4	QP	N	GND
11.216000	44.30	10.6	60	15.7	QP	N	GND
11.318000	46.20	10.6	60	13.8	QP	N	GND

MEASUREMENT RESULT: "CTL141203315_fin2"

12/3/2014 11:26AM

Frequency MHz	Level dBµV	Transd dB	Limit dBµV	Margin dB	Detector	Line	PE
0.314000	40.10	10.2	50	9.8	AV	N	GND
0.512000	41.40	10.2	46	4.6	AV	N	GND
0.620000	39.70	10.2	46	6.3	AV	N	GND
0.722000	36.90	10.2	46	9.1	AV	N	GND
1.502000	37.50	10.3	46	8.5	AV	N	GND
2.804000	37.70	10.4	46	8.3	AV	N	GND

SCAN TABLE: "Voltage (9K-30M)FIN"

Short Description: 150K-30M Voltage

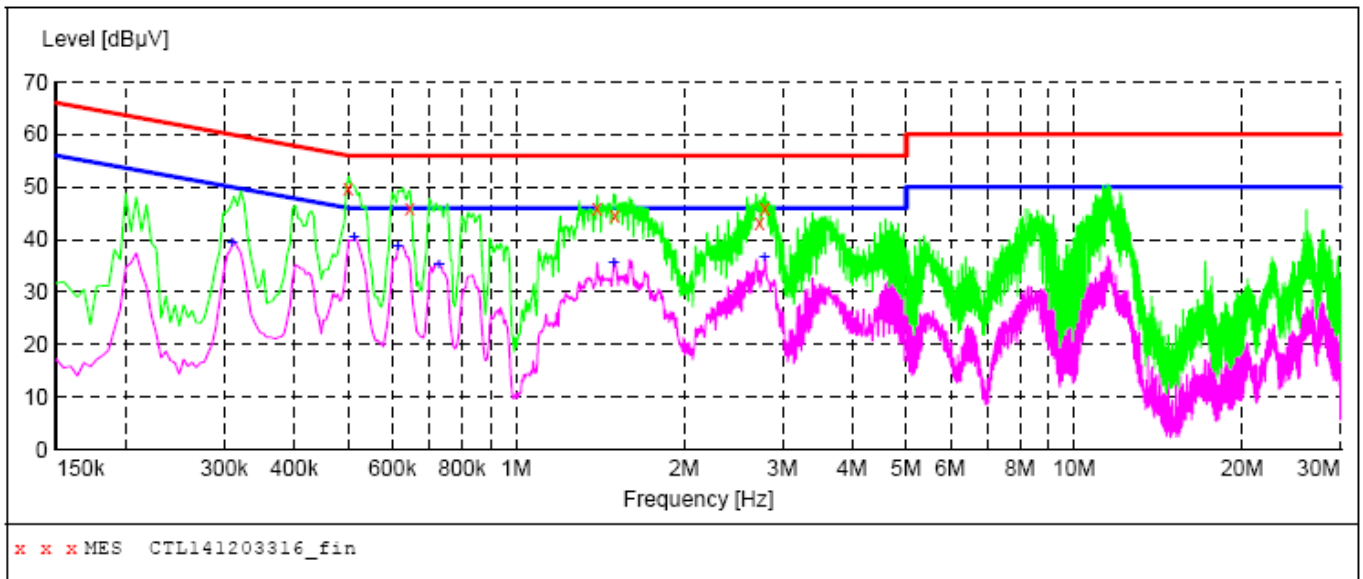

MEASUREMENT RESULT: "CTL141203316_fin"

12/3/2014 11:30AM

Frequency MHz	Level dBµV	Transd dB	Limit dBµV	Margin dB	Detector	Line	PE
0.500000	49.70	10.2	56	6.3	QP	L1	GND
0.644000	46.10	10.2	56	9.9	QP	L1	GND
1.394000	46.00	10.3	56	10.0	QP	L1	GND
1.502000	44.40	10.3	56	11.6	QP	L1	GND
2.726000	43.30	10.4	56	12.7	QP	L1	GND
2.786000	46.00	10.4	56	10.0	QP	L1	GND

MEASUREMENT RESULT: "CTL141203316_fin2"

12/3/2014 11:30AM

Frequency MHz	Level dBµV	Transd dB	Limit dBµV	Margin dB	Detector	Line	PE
0.310000	39.40	10.2	50	10.6	AV	L1	GND
0.512000	40.30	10.2	46	5.7	AV	L1	GND
0.614000	38.70	10.2	46	7.3	AV	L1	GND
0.728000	35.10	10.2	46	10.9	AV	L1	GND
1.496000	35.50	10.3	46	10.5	AV	L1	GND
2.786000	36.60	10.4	46	9.4	AV	L1	GND

4.2. Radiated Emission Test

TEST CONFIGURATION

(A) Radiated Emission Test Set-Up, Frequency Below 30MHz

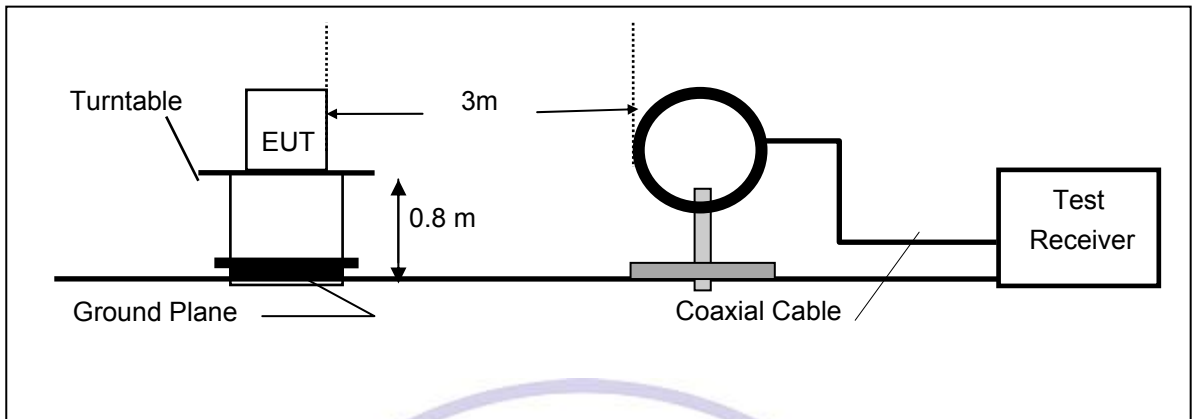

(B) Radiated Emission Test Set-Up, Frequency Below 1000MHz

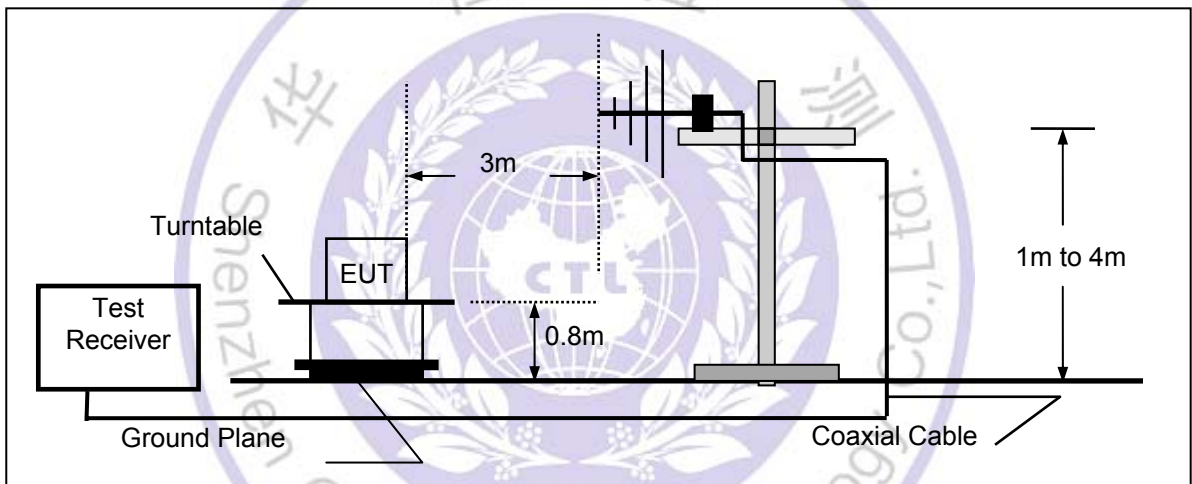

(C) Radiated Emission Test Set-Up, Frequency above 1000MHz

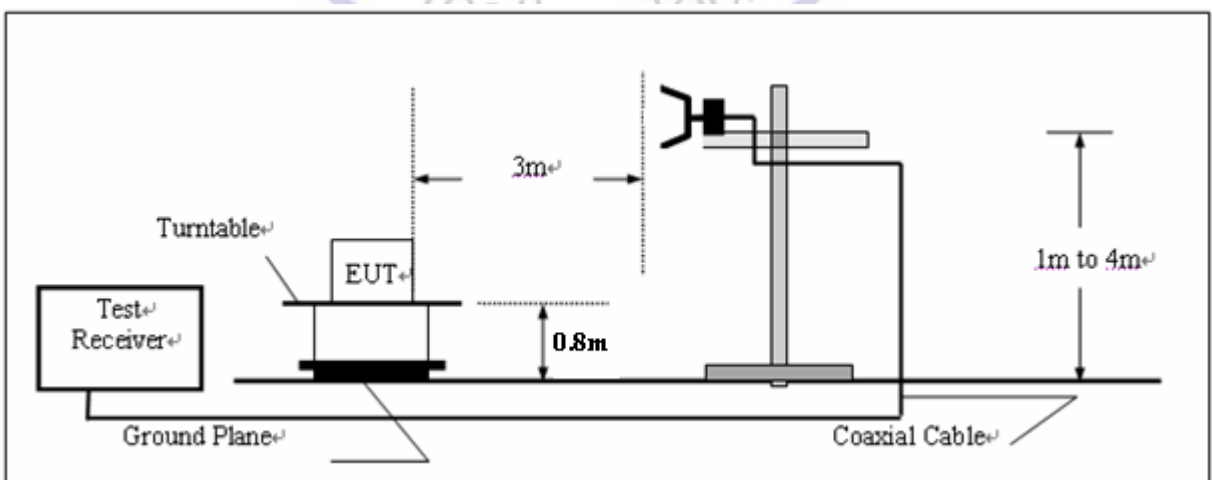

FIELD STRENGTH CALCULATION

The field strength is calculated by adding the Antenna Factor and Cable Factor and subtracting the Amplifier Gain and Duty Cycle Correction Factor(if any) from the measured reading. The basic equation with a sample calculation is as follows:

$$FS = RA + AF + CL - AG$$

Where FS = Field Strength	CL = Cable Attenuation Factor (Cable Loss)
RA = Reading Amplitude	AG = Amplifier Gain
AF = Antenna Factor	

TEST PROCEDURE

1. The testing follows FCC KDB Publication No. 558074 D01 v03r02 (Measurement Guidelines of DTS).
2. The EUT was placed on a turn table which is 0.8m above ground plane.
3. Maximum procedure was performed by raising the receiving antenna from 1m to 4m and rotating the turn table from 0° to 360° to acquire the highest emissions from EUT
4. And also, each emission was to be maximized by changing the polarization of receiving antenna both horizontal and vertical.
5. Span = wide enough to fully capture the emission being measured; RBW = 1 MHz for f > 1 GHz, 100 kHz for f < 1 GHz; VBW ≥ RBW; Sweep = auto; Detector function = peak; Trace = max hold.
6. Repeat above procedures until all frequency measurements have been completed.

Note:

When doing emission measurement above 1GHz, the horn antenna will be bended down a little (as horn antenna has the narrow beamwidth) in order to keeping the antenna in the “cone of radiation” of EUT. The 3dB beamwidth is 60 degrees for H-plane and 90 degrees for E-plane.

LIMIT

For unintentional device, according to § 15.109(a), except for Class A digital devices, the field strength of radiated emissions from unintentional radiators at a distance of 3 meters shall not exceed the following values:

Frequency (MHz)	Distance (Meters)	Radiated (dBµV/m)	Radiated (µV/m)
30-88	3	40.0	100
88-216	3	43.5	150
216-960	3	46.0	200
Above 960	3	54.0	500

For intentional device, according to § 15.209(a), the general requirement of field strength of radiated emissions from intentional radiators at a distance of 3 meters shall not exceed the above table. According to § 15.247(d), in any 100kHz bandwidth outside the frequency band in which the EUT is operating, the radio frequency power that is produced by the intentional radiator shall be at least 20dB below that in the 100kHz bandwidth within the band that contains the highest level of desired power.

TEST RESULTS

Below 1GHz:

The radiated measurement are performed the each test mode (b/g/n) and channel (low/mid/high), the datum recorded below (802.11b mode, the middle channel) is the worst case for all the test mode and channel.

SWEEP TABLE: "test (30M-1G)"

Short Description:		Field Strength			
Start	Stop	Detector	Meas. Time	IF Bandw.	Transducer
Frequency	Frequency				
30.0 MHz	1.0 GHz	MaxPeak	300.0 ms	120 kHz	JB1

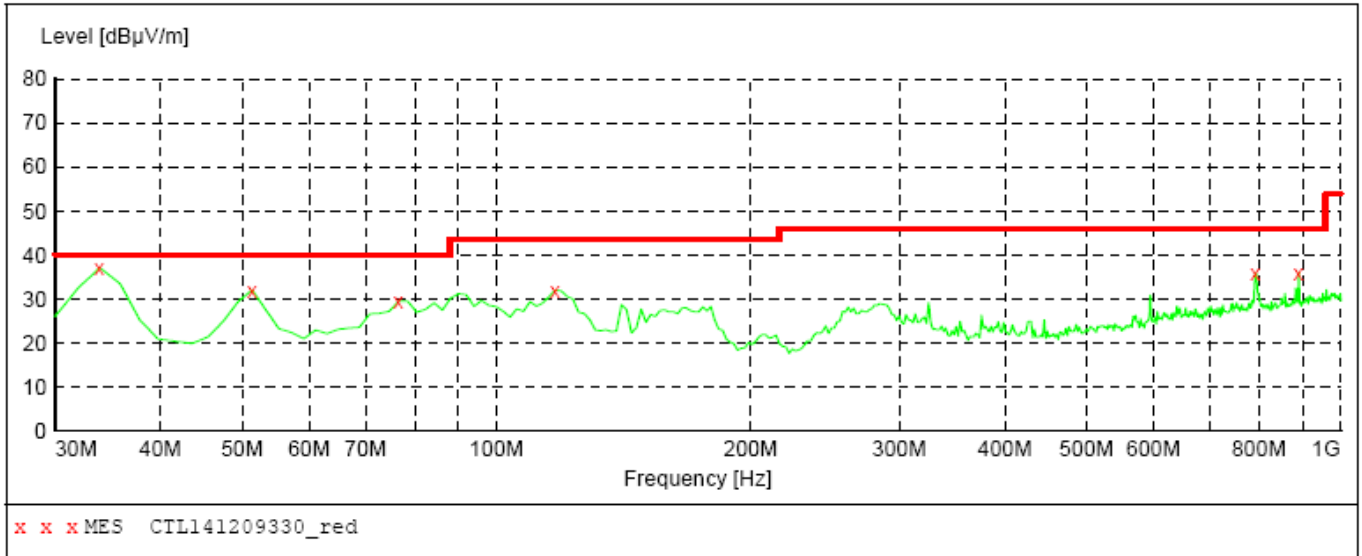

MEASUREMENT RESULT: "CTL141209330_red"

12/9/2014 12:28PM

Frequency MHz	Level dBµV/m	Transd dB	Limit dBµV/m	Margin dB	Det.	Height cm	Azimuth deg	Polarization
33.880000	37.10	18.1	40.0	2.9	---	0.0	0.00	VERTICAL
51.340000	32.00	8.3	40.0	8.0	---	0.0	0.00	VERTICAL
76.560000	29.50	8.6	40.0	10.5	---	0.0	0.00	VERTICAL
117.300000	31.90	15.1	43.5	11.6	---	0.0	0.00	VERTICAL
792.420000	35.90	24.8	46.0	10.1	---	0.0	0.00	VERTICAL
891.360000	36.00	25.9	46.0	10.0	---	0.0	0.00	VERTICAL



SWEEP TABLE: "test (30M-1G)"

Short Description:		Field Strength			
Start	Stop	Detector	Meas. Time	IF Bandw.	Transducer
30.0 MHz	1.0 GHz	MaxPeak	300.0 ms	120 kHz	JB1

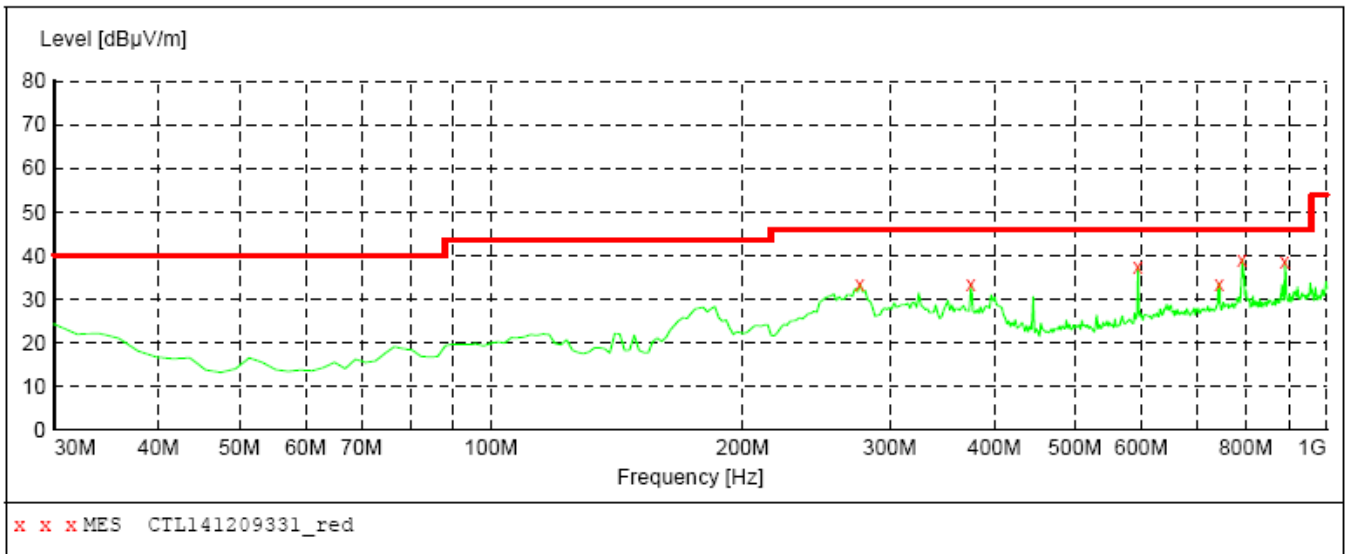

MEASUREMENT RESULT: "CTL141209331_red"

12/9/2014 12:30PM

Frequency MHz	Level dBµV/m	Transd dB	Limit dBµV/m	Margin dB	Det.	Height cm	Azimuth deg	Polarization
276.380000	33.40	15.4	46.0	12.6	---	0.0	0.00	HORIZONTAL
375.320000	33.40	17.7	46.0	12.6	---	0.0	0.00	HORIZONTAL
594.540000	37.40	21.7	46.0	8.6	---	0.0	0.00	HORIZONTAL
743.920000	33.60	24.2	46.0	12.4	---	0.0	0.00	HORIZONTAL
792.420000	39.10	24.8	46.0	6.9	---	0.0	0.00	HORIZONTAL
891.360000	38.60	25.9	46.0	7.4	---	0.0	0.00	HORIZONTAL



Above 1GHz:

802.11b

CH	Antenna	Frequency (MHz)	Reading Level (dBuV/m)	Factor (dB)	Measure Level (dBuV/m)	Limit (dBuV/m)	Margin (dB)	Detector
1	V	2412.0	73.3	30.8	104.1	Fundamental	/	PK
	V	307.4	18.4	14.8	33.2	46	12.8	QP
	V	500.0	10.8	19.7	30.5	46	15.5	QP
	V	3200.0	46.7	-0.6	46.1	54(note3)	7.9	PK
	V	4825.0	47.2	2.6	49.8	54(note3)	4.2	PK
	V	7239.0	55.0	8.1	63.1	74	10.9	PK
	V	7236.0	38.2	8.9	47.1	54	6.9	AV
	H	24000.0	59.7	-8.9	50.8	54(note3)	3.2	PK
6	V	2437.0	72.7	31.2	103.9	Fundamental	/	PK
	V	317.1	15.9	15.2	31.1	46	14.9	QP
	V	571.6	14.2	21.2	35.4	46	10.6	QP
	V	3200.0	48.8	-0.6	48.2	54(note3)	5.8	PK
	V	4876.0	46.9	2.8	49.7	54(note3)	4.3	PK
	V	7315.5	57.0	8.8	65.8	74	8.2	PK
	V	7311.0	39.0	8.1	47.1	54	6.9	AV
	H	24000.0	59.1	-8.9	50.2	54(note3)	3.8	PK
11	V	2462.0	72.9	30.9	103.8	Fundamental	/	PK
	V	326.3	15.0	14.9	29.9	46	16.1	QP
	H	582.0	12.9	21.2	34.1	46	11.9	QP
	V	3200.0	47.8	-0.6	47.2	54(note3)	6.8	PK
	V	4927.0	45.1	3.0	48.1	54(note3)	5.9	PK
	V	7383.5	55.3	8.9	64.2	74	9.8	PK
	V	7386.0	34.6	8.9	43.5	54	10.5	AV
	H	24000.0	59.3	-8.9	50.4	54(note3)	3.6	PK

Note: 1. Measure Level = Reading Level + Factor.

2. The test results which are attenuated more than 20 dB below the permissible value limit (the test frequency range: 9kHz~30MHz, 18GHz~25GHz), therefore no data appear in the report.

3. This limit applies for using average detector, if the test result on peak is lower than average limit, then average measurement needn't be performed.

802.11g

CH	Antenna	Frequency (MHz)	Reading Level (dBuV/m)	Factor (dB)	Measure Level (dBuV/m)	Limit (dBuV/m)	Margin (dB)	Detector
1	V	2411.9	70.6	31.9	102.5	Fundamental	/	PK
	H	245.8	15.5	15.7	31.2	46	14.8	QP
	H	541.4	14.4	21.3	35.7	46	10.3	QP
	V	3200.0	48.6	-0.6	48.0	54(note3)	6.0	PK
	V	4824.0	44.6	2.6	47.2	54(note3)	6.8	PK
	V	7236.0	56.5	8.9	65.4	74	8.6	PK
	V	7239.0	38.3	8.9	47.2	54	6.8	AV
	H	24000.0	59.8	-8.9	50.9	54(note3)	3.1	PK
6	V	2437.0	71.9	31.2	103.1	Fundamental	/	PK
	V	359.6	19.7	14.8	34.5	46	11.5	QP
	V	638.9	8.5	21.2	29.7	46	16.3	QP
	V	3200.0	47.7	-0.6	47.1	54(note3)	6.9	PK
	V	4876.0	46.3	2.8	49.1	54(note3)	4.9	PK
	V	7298.5	56.1	8.8	64.9	74	9.1	PK
	H	7298.9	38.4	8.8	47.2	54	6.8	AV
	H	24000.0	59.6	-8.9	50.7	54(note3)	3.3	PK
11	V	2462.3	72.0	30.9	102.9	Fundamental	/	PK
	H	698.7	8.9	21.2	30.1	46	15.9	QP
	V	282.6	14.8	14.7	29.5	46	16.5	QP
	V	3200.0	49.4	-0.6	48.8	54(note3)	5.2	PK
	V	4927.0	43.4	3.0	46.4	54(note3)	7.6	PK
	V	7386.0	58.3	8.9	67.2	74	6.8	PK
	V	7392.0	39.2	8.9	48.1	54	5.9	AV
	H	24000.0	59.3	-8.9	50.4	54(note3)	3.6	PK

Note: 1. Measure Level = Reading Level + Factor.

2. The test results which are attenuated more than 20 dB below the permissible value limit (the test frequency range: 9kHz~30MHz, 18GHz~25GHz), therefore no data appear in the report.

3. This limit applies for using average detector, if the test result on peak is lower than average limit, then average measurement needn't be performed.

802.11n(20MHz)

CH	Antenna	Frequency (MHz)	Reading Level (dBuV/m)	Factor (dB)	Measure Level (dBuV/m)	Limit (dBuV/m)	Margin (dB)	Detector
1	V	2412.1	71.4	30.7	102.1	Fundamental	/	PK
	H	542.9	7.2	21.2	28.4	46	17.6	QP
	H	362.8	21.2	15.1	36.3	46	9.7	QP
	V	3200.0	48.8	-0.6	48.2	54(note3)	5.8	PK
	V	4824.0	43.3	2.6	45.9	54(note3)	8.1	PK
	V	7236.0	57.2	8.9	66.1	74	7.9	PK
	V	7239.0	37.4	8.9	46.3	54	7.7	AV
	H	24000.0	59.4	-8.9	50.5	54(note3)	3.5	PK
6	V	2437.0	70.6	31.2	101.8	Fundamental	/	PK
	H	597.6	10.5	21.2	31.7	46	14.3	QP
	H	320.3	17.9	16.0	33.9	46	12.1	QP
	V	3200.0	46.7	-0.6	46.1	54(note3)	7.9	PK
	V	4876.0	46.3	2.8	49.1	54(note3)	4.9	PK
	V	7307.0	56.5	8.8	65.3	74	8.7	PK
	V	7310.6	35.8	8.8	44.6	54	9.4	AV
	H	24000.0	59.3	-8.9	50.4	54(note3)	3.6	PK
11	V	2462.0	71.5	30.9	102.4	Fundamental	/	PK
	H	364.3	16.8	14.7	31.5	46	14.5	QP
	H	541.9	18.0	21.2	39.2	46	6.8	QP
	V	3200.0	47.7	-0.6	47.1	54(note3)	6.9	PK
	V	4924.0	45.6	3.0	48.6	54(note3)	5.4	PK
	V	7375.0	57.2	9.0	66.2	74	7.8	PK
	V	7378.3	38.3	9.0	47.3	54	6.7	AV
	H	24000.0	59.2	-8.9	50.3	54(note3)	3.7	PK

Note: 1. Measure Level = Reading Level + Factor.

2. The test results which are attenuated more than 20 dB below the permissible value limit (the test frequency range: 9kHz~30MHz, 18GHz~25GHz), therefore no data appear in the report.

3. This limit applies for using average detector, if the test result on peak is lower than average limit, then average measurement needn't be performed.

4.3. 6dB Bandwidth Measurement

TEST CONFIGURATION

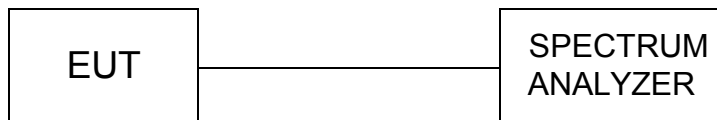

TEST PROCEDURE

1. The testing follows FCC KDB Publication No. 558074 D01 v03r02 (Measurement Guidelines of DTS).
2. The RF output of EUT was connected to the spectrum analyzer by a low loss cable.
3. Make the measurement with the spectrum analyzer's resolution bandwidth (RBW) = 100 kHz. In order to make an accurate measurement, set the span greater than RBW. The 6 dB bandwidth must be greater than 500 kHz.
4. The marker-delta reading at this point is the 6 dB bandwidth of the emission.

LIMIT

For digital modulation systems, the minimum 6 dB bandwidth shall be at least 500 kHz.

TEST RESULTS

Product	:	Enjoy TV
Test Item	:	6dB Occupied Bandwidth
Test Mode	:	Mode 1: Transmit by 802.11b

Channel No.	Frequency (MHz)	Occupied Bandwidth (kHz)	Limit (kHz)	Result
01	2412	10600	500	Pass
06	2437	10400	500	Pass
11	2462	10400	500	Pass

Channel 01 (2412MHz)

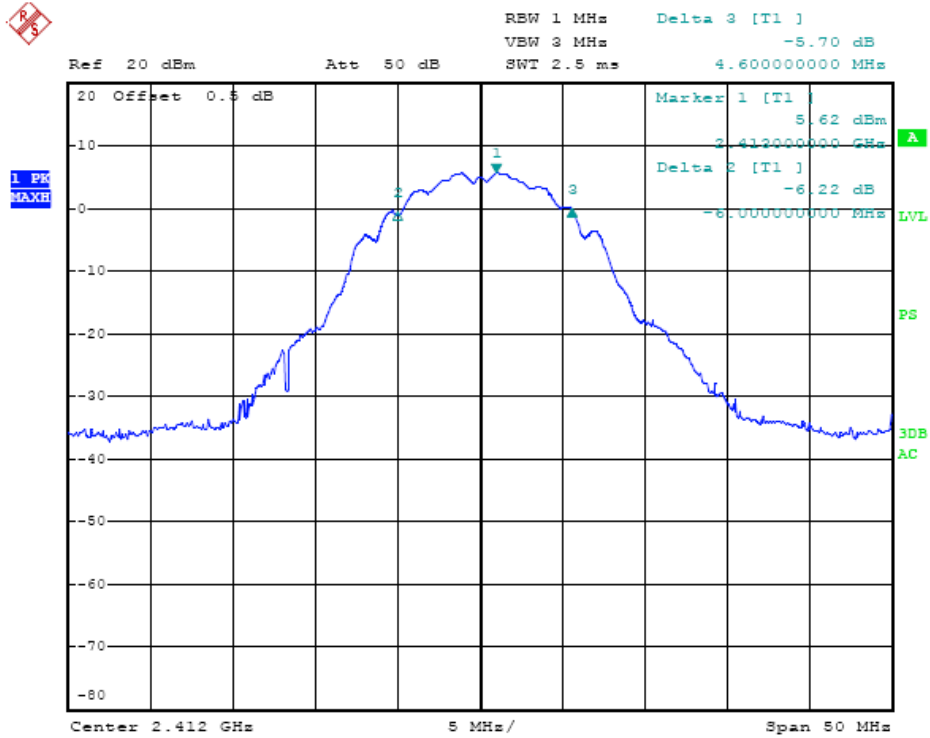

Channel 06 (2437MHz)

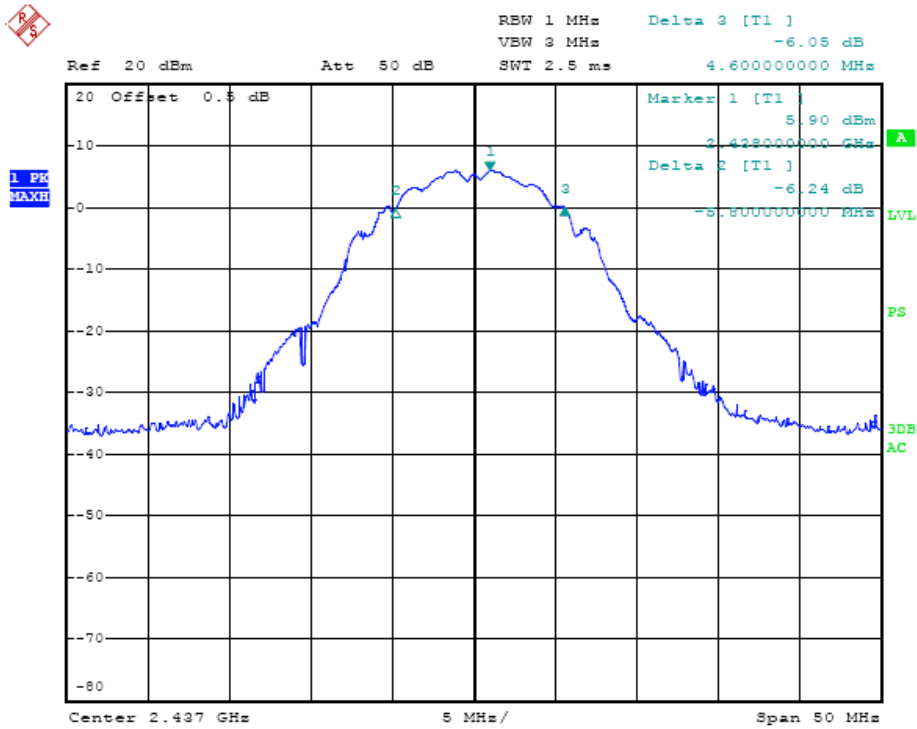

Channel 11 (2462MHz)

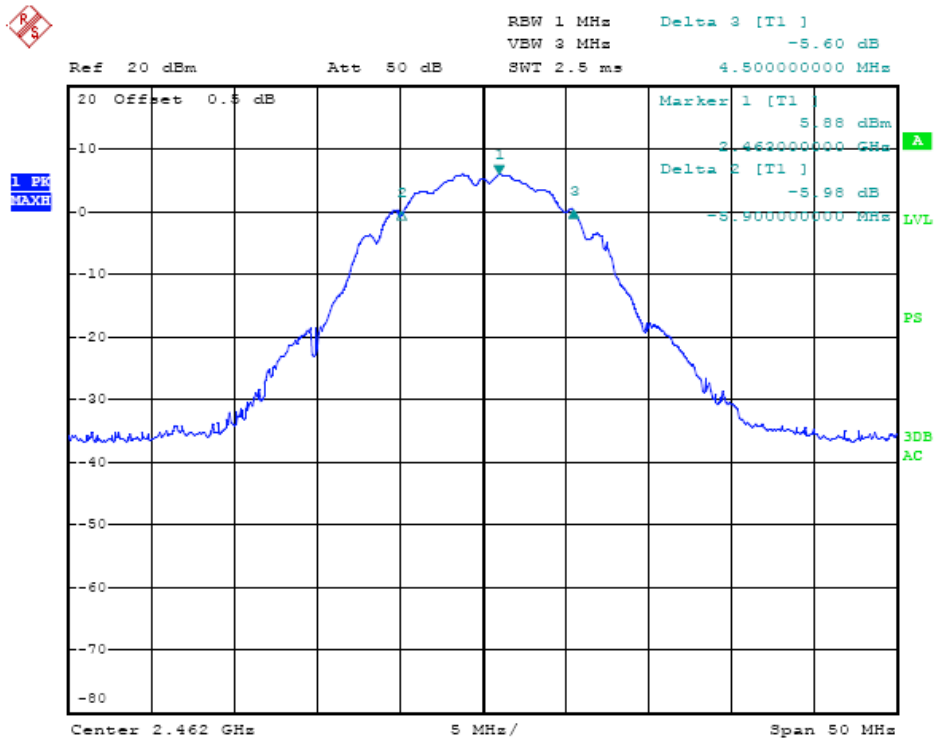

Product	:	Enjoy TV
Test Item	:	6dB Occupied Bandwidth
Test Mode	:	Mode 2: Transmit by 802.11g

Channel No.	Frequency (MHz)	Occupied Bandwidth (kHz)	Limit (kHz)	Result
01	2412	16800	500	Pass
06	2437	16900	500	Pass
11	2462	16800	500	Pass

Channel 01 (2412MHz)

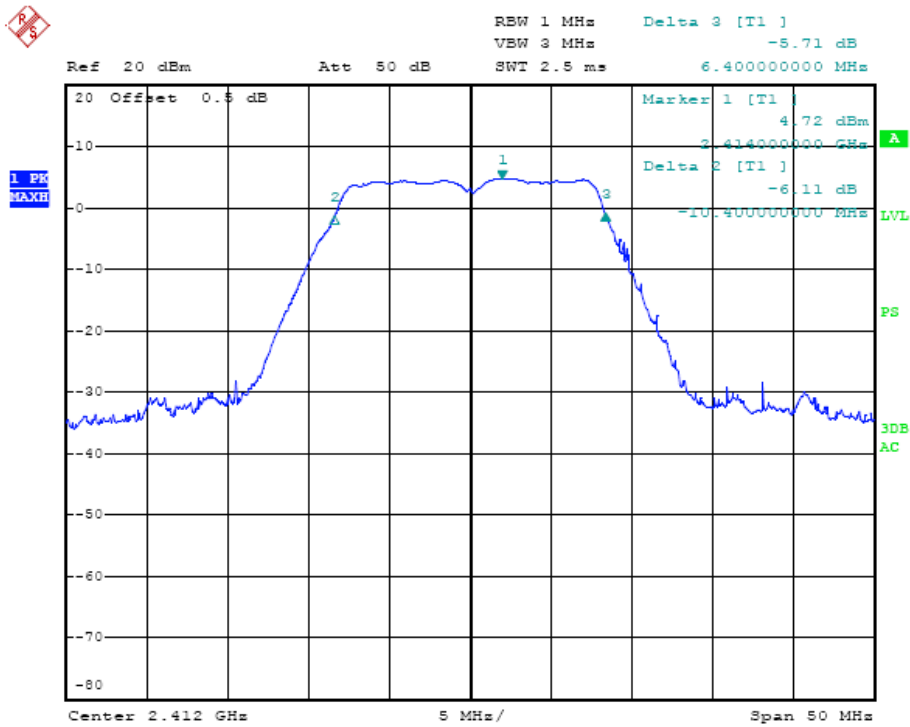

Channel 06 (2437MHz)

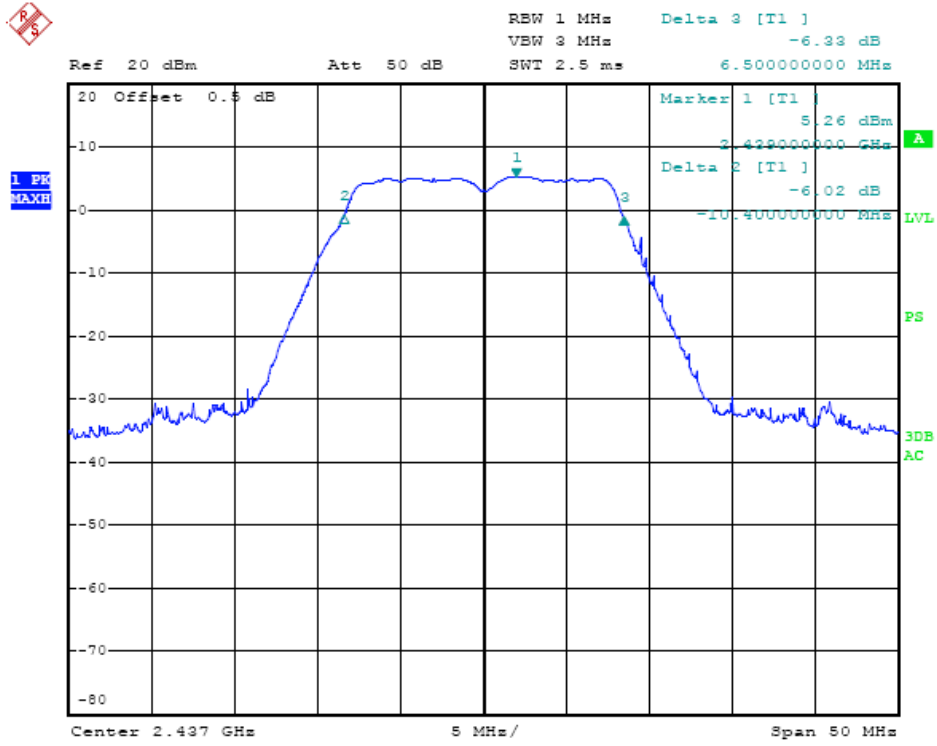

Channel 11 (2462MHz)

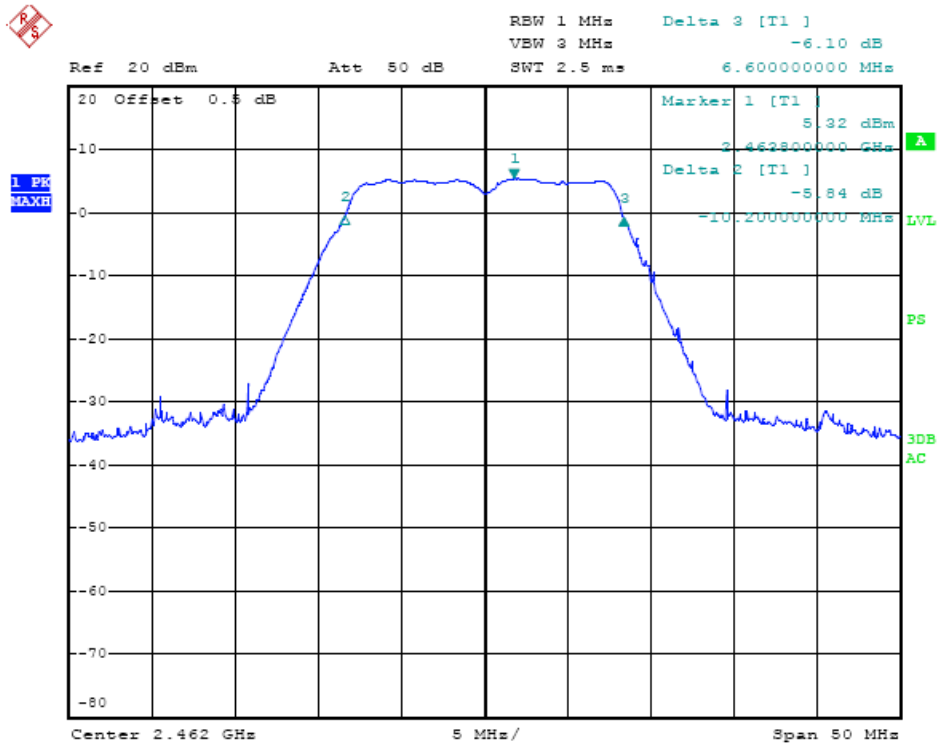

Product	:	Enjoy TV
Test Item	:	6dB Occupied Bandwidth
Test Mode	:	Mode 3: Transmit by 802.11n (20MHz)

Channel No.	Frequency (MHz)	Occupied Bandwidth (kHz)	Limit (kHz)	Result
01	2412	18100	500	Pass
06	2437	18100	500	Pass
11	2462	18100	500	Pass

Channel 01 (2412MHz)

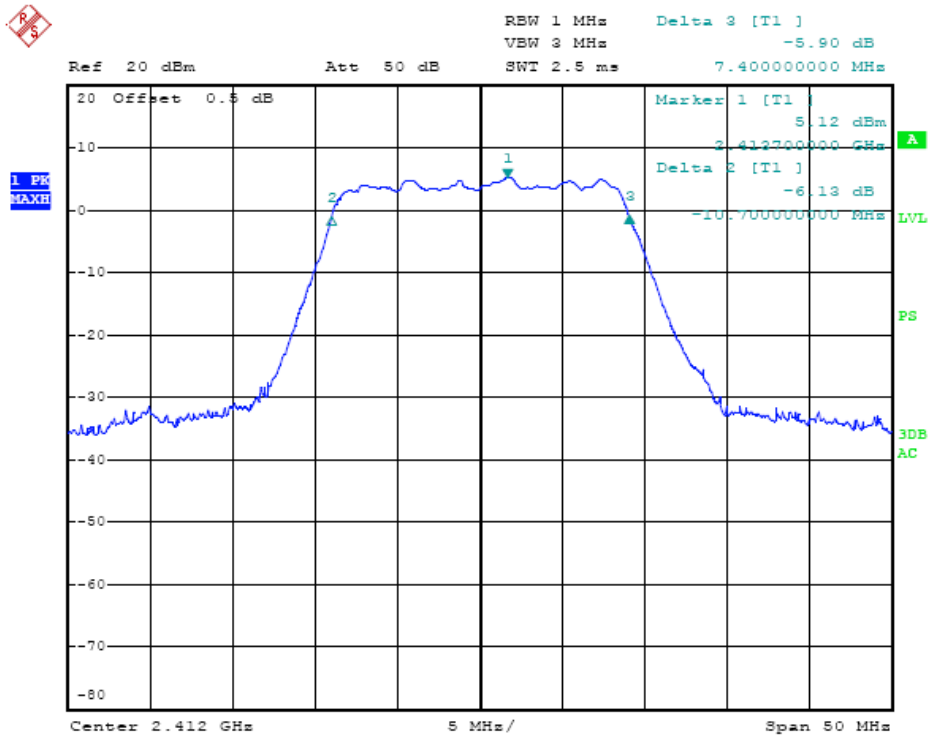

Channel 06 (2437MHz)

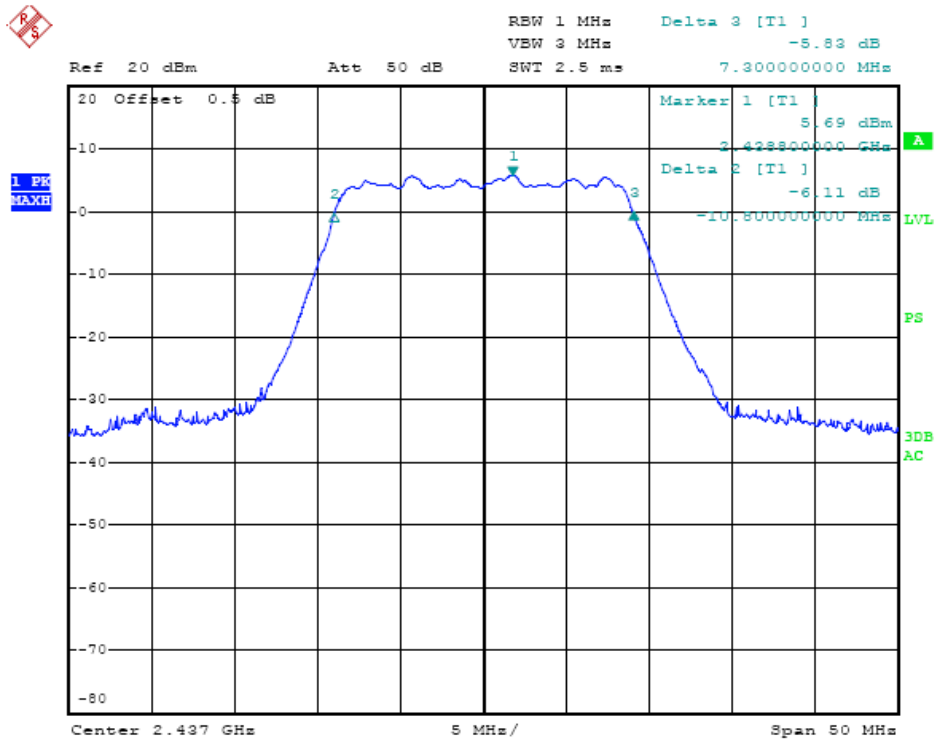

Channel 11 (2462MHz)

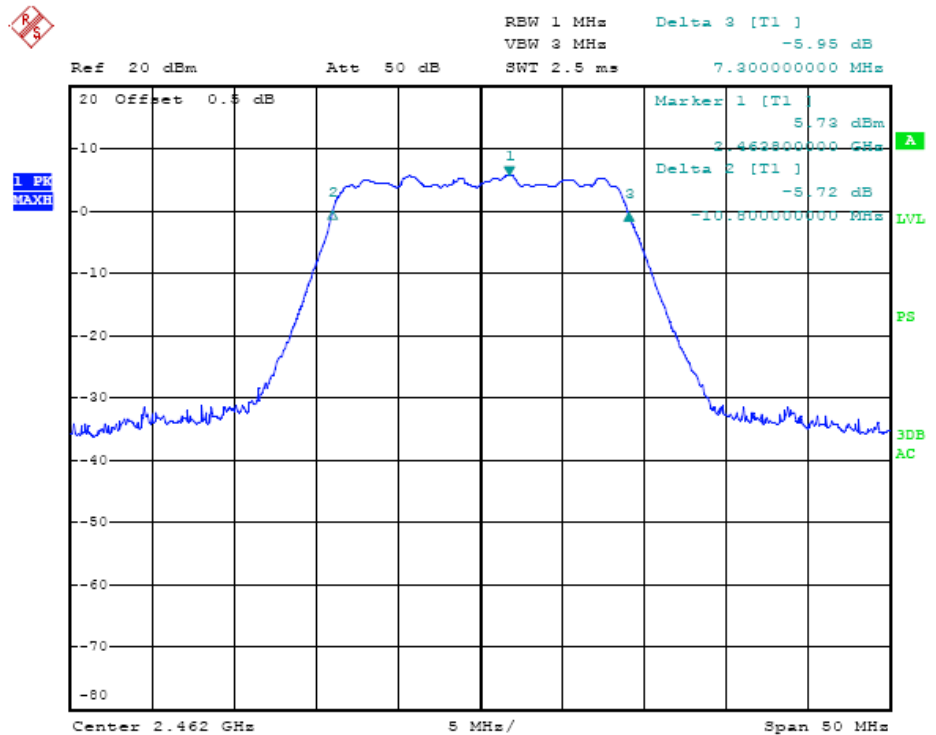

4.4. Maximum Peak Output Power

TEST CONFIGURATION

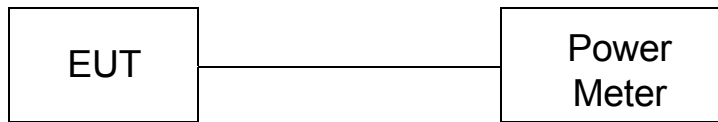

TEST PROCEDURE

According to C63.10 -2009 and KDB558074 D01 v03r02, The EUT was directly connected to the power meter / spectrum analyzer and antenna output port as show in the block diagram as TEST CONFIGURATION shows.

Use the wideband power meter to test peak power and record the result.

LIMIT

The Peak Output Power Measurement limits are 30dBm.

TEST RESULTS

Product	:	Enjoy TV
Test Item	:	Power Output
Test Mode	:	Mode 1: Transmit by 802.11b

Channel No.	Frequency (MHz)	Measurement Power Output (dBm)	Limit (dBm)	Result
1	2412	9.76	30.00	Pass
6	2437	9.58	30.00	Pass
11	2462	9.72	30.00	Pass

Product	:	Enjoy TV
Test Item	:	Power Output
Test Mode	:	Mode 2: Transmit by 802.11g

Channel No.	Frequency (MHz)	Measurement Power Output (dBm)	Limit (dBm)	Result
1	2412	8.73	30.00	Pass
6	2437	8.91	30.00	Pass
11	2462	8.79	30.00	Pass

Product	:	Enjoy TV
Test Item	:	Power Output
Test Mode	:	Mode 3: Transmit by 802.11n(20MHz)

Channel No.	Frequency (MHz)	Measurement Power Output (dBm)	Limit (dBm)	Result
1	2412	7.98	30.00	Pass
6	2437	8.04	30.00	Pass
11	2462	8.13	30.00	Pass

Note: The test results including the cable lose.



4.5. Band Edge Measurement

TEST CONFIGURATION

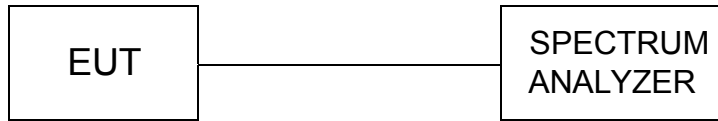

TEST PROCEDURE

The band edge compliance of RF radiated emission should be measured by following the guidance in ANSI C63.10 and FCC KDB Publication No. 558074 D01 v03r02 (Measurement Guidelines of DTS) with respect to maximizing the emission by rotating the EUT, measuring the emission while the EUT is situated in three orthogonal planes (if appropriate), adjusting the measurement antenna height and polarization etc. Set RBW=100kHz and VBM= 300KHz to measure the peak field strength and set RBW to 1MHz and VBW to 10Hz to measure the average radiated field strength.

The conducted RF band edge was measured by using a spectrum analyzer. Set span wide enough to capture the highest in-band emission and the emission at the band edge. Set RBW =100 kHz VBW ≥300 kHz, to measure the conducted peak band edge.

Connect the spectrum analyzer to the EUT using an appropriate RF cable connected to the EUT output. Configure the spectrum analyzer settings as described below (be sure to enter all losses between the unlicensed wireless device output and the spectrum analyzer).

- Span: Set Span for minimum 50 MHz - Reference Level: 110 dB μ V (corrected for gains and losses of test antenna factor, preamp gain and cable loss) - Attenuation: 10 dB
- Sweep Time: Coupled - Resolution Bandwidth: Up to and including 1 GHz = ≥ 100 kHz
- Resolution Bandwidth: Above 1 GHz = 1 MHz - Video Bandwidth: Below 1 GHz = 300 kHz
- Video Bandwidth: Up to and including 1 GHz = ≥ 3 MHz for peak and 10 Hz for average
- Detector: Peak

Place a marker at the end of the restricted band closest to the transmit frequency to show compliance. Also measure any emissions in the restricted bands. Save the spectrum analyzer plot. Repeat for each power and modulation for lowest and highest channel.

LIMIT

1. Below -20dB of the highest emission level in operating band.
2. Fall in the restricted bands listed in section 15.205. The maximum permitted average field strength is listed in section 15.209(see Section 15.205(c)).

Frequency (MHz)	Limit Average (dBuv/m)	Limit Peak (dBuv/m)
Below 2390 or Above 2483.5	54	74

TEST RESULTS

Transmitting mode: 802.11b

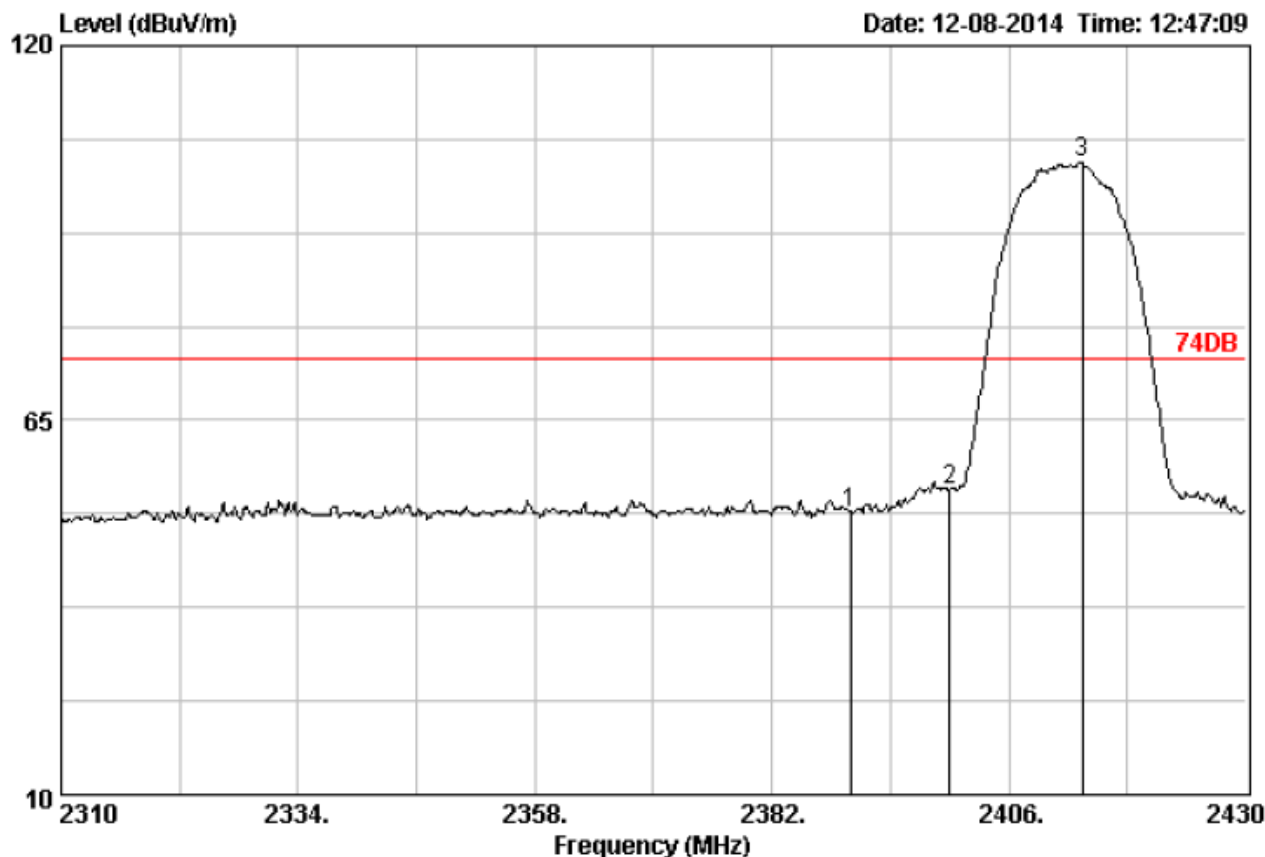

```

Site no.      : 3m Chamber                      Data no. : 1171
Dis. / Ant.   : 3m DRH-118                    Ant. pol. : HORIZONTAL
Limit        : 74DB
Env. / Ins.   : 23*C/54%
Engineer     :
EUT          :
Power        :
M/N         :
Test Mode    :
    
```

	Freq. (MHz)	Ant. Factor (dB)	Cable Loss (dB)	Reading (dBuV)	Emission		Margin (dB)	Remark
					Level (dBuV/m)	Limits (dBuV/m)		
1	2390.00	28.78	4.61	53.40	51.43	74.00	22.57	Peak
2	2400.00	28.78	4.61	56.69	54.72	74.00	19.28	Peak
3	2413.44	28.81	4.63	104.66	102.74	74.00	-28.74	Peak

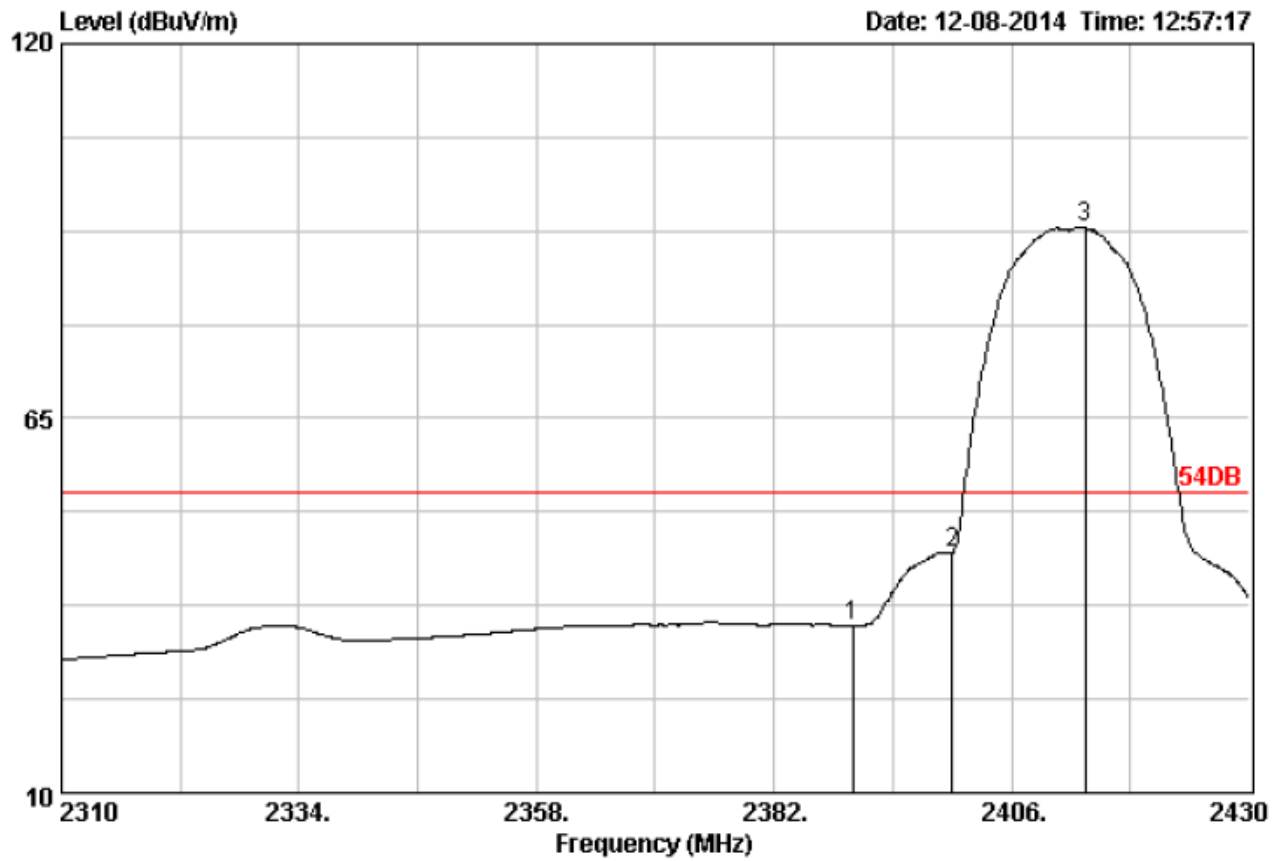

Site no. : 3m Chamber Data no. : 1173
 Dis. / Ant. : 3m DRH-118 Ant. pol. : HORIZONTAL
 Limit : 54DB
 Env. / Ins. : 23*C/54%
 Engineer :
 EUT :
 Power :
 M/N :
 Test Mode :

	Freq. (MHz)	Ant. Factor (dB)	Cable Loss (dB)	Reading (dBuV)	Emission Level (dBuV/m)	Limits (dBuV/m)	Margin (dB)	Remark
1	2390.00	28.78	4.61	36.60	34.63	54.00	19.37	Average
2	2400.00	28.78	4.61	47.18	45.21	54.00	8.79	Average
3	2413.44	28.81	4.63	95.09	93.17	54.00	-39.17	Average

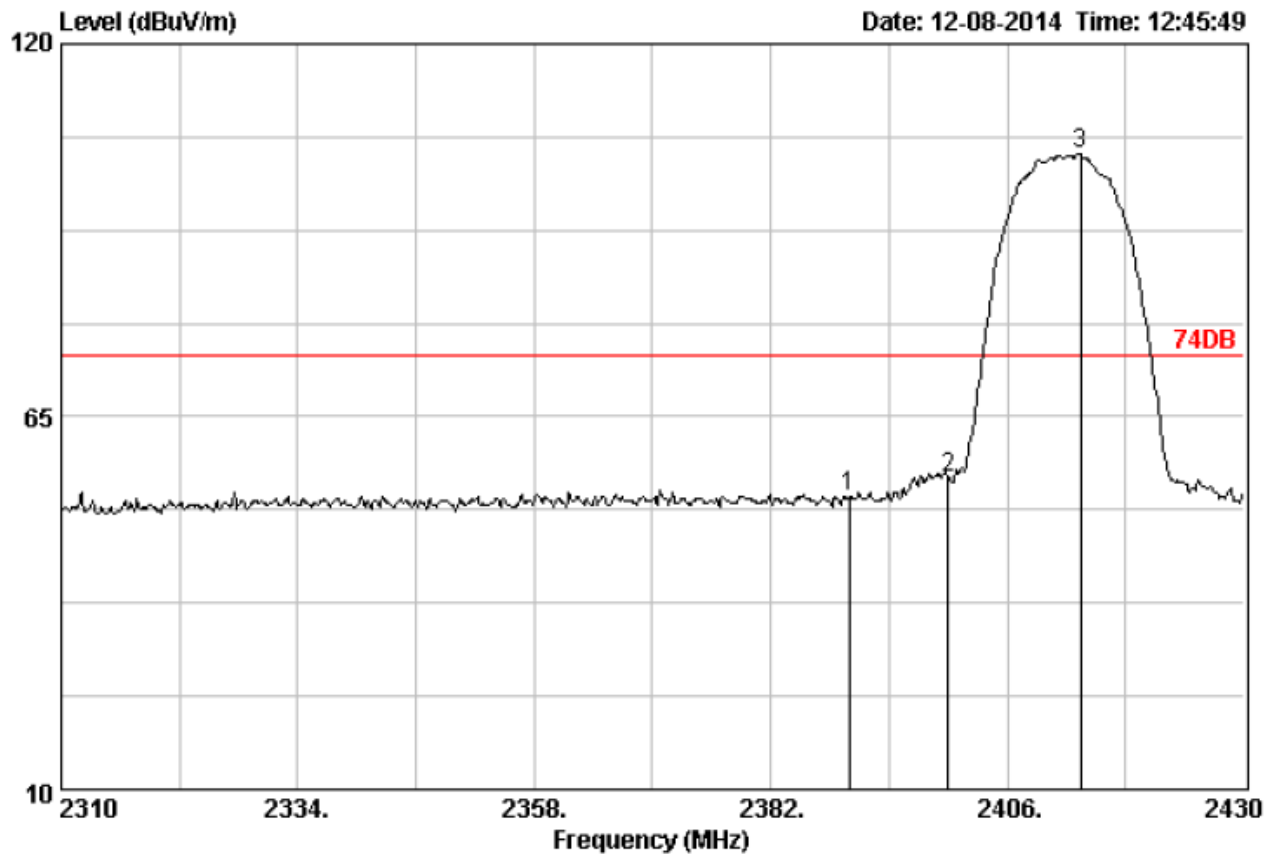

Site no. : 3m Chamber
 Dis. / Ant. : 3m DRH-118
 Limit : 74DB
 Env. / Ins. : 23*C/54%
 Engineer :
 EUT :
 Power :
 M/N :
 Test Mode :

Data no. : 1170
 Ant. pol. : VERTICAL

No.	Freq. (MHz)	Ant. Cable		Emission				Remark
		Factor (dB)	Loss (dB)	Reading (dBuV)	Level (dBuV/m)	Limits (dBuV/m)	Margin (dB)	
1	2390.00	28.78	4.61	55.04	53.07	74.00	20.93	Peak
2	2400.00	28.78	4.61	57.94	55.97	74.00	18.03	Peak
3	2413.44	28.81	4.63	105.72	103.80	74.00	-29.80	Peak

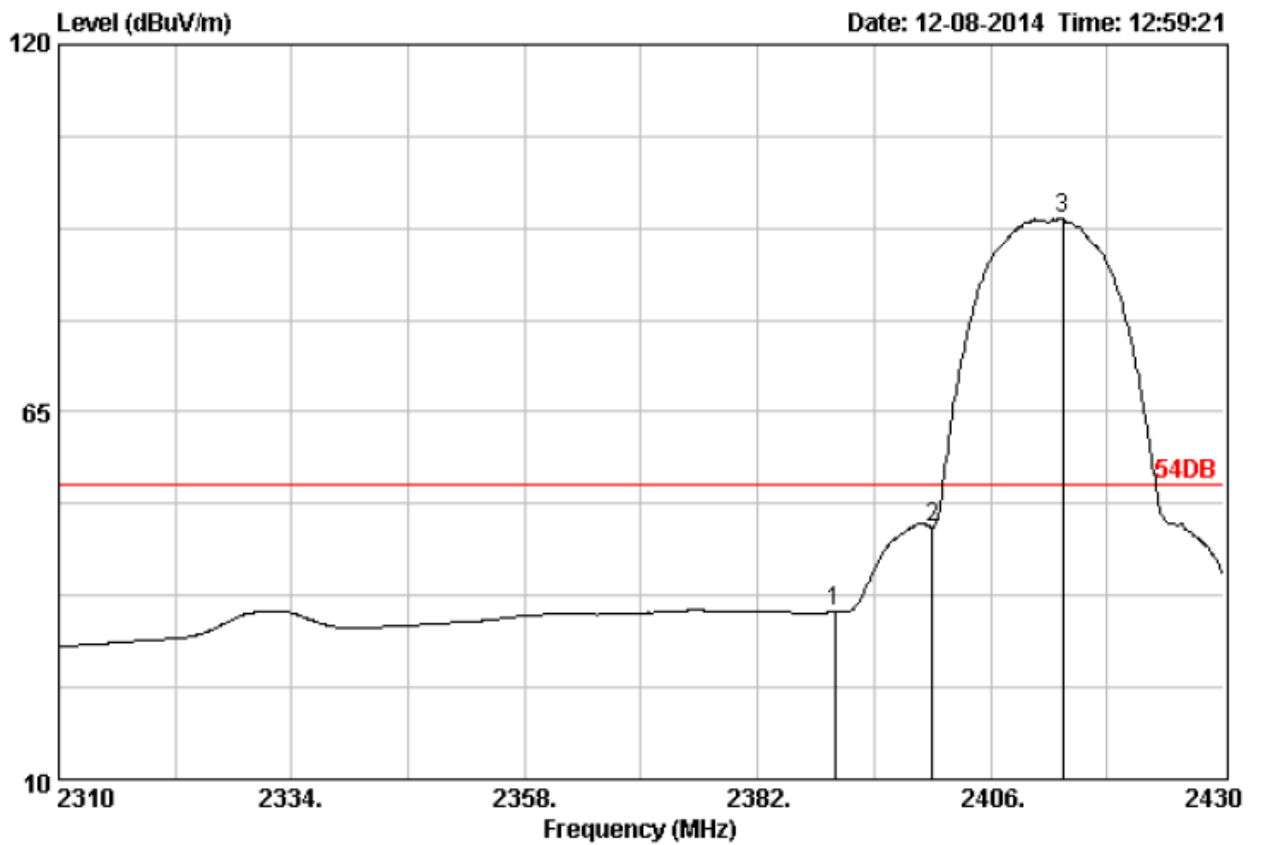

Site no. : 3m Chamber
 Dis. / Ant. : 3m DRH-118
 Limit : 54DB
 Env. / Ins. : 23*C/54%
 Engineer :
 EUT :
 Power :
 M/N :
 Test Mode :

Data no. : 1174
 Ant. pol. : VERTICAL

	Freq. (MHz)	Ant. Factor (dB)	Cable Loss (dB)	Reading (dBuV)	Emission			Remark
					Level (dBuV/m)	Limits (dBuV/m)	Margin (dB)	
1	2390.00	28.78	4.61	37.00	35.03	54.00	18.97	Average
2	2400.00	28.78	4.61	49.71	47.74	54.00	6.26	Average
3	2413.44	28.81	4.63	95.94	94.02	54.00	-40.02	Average

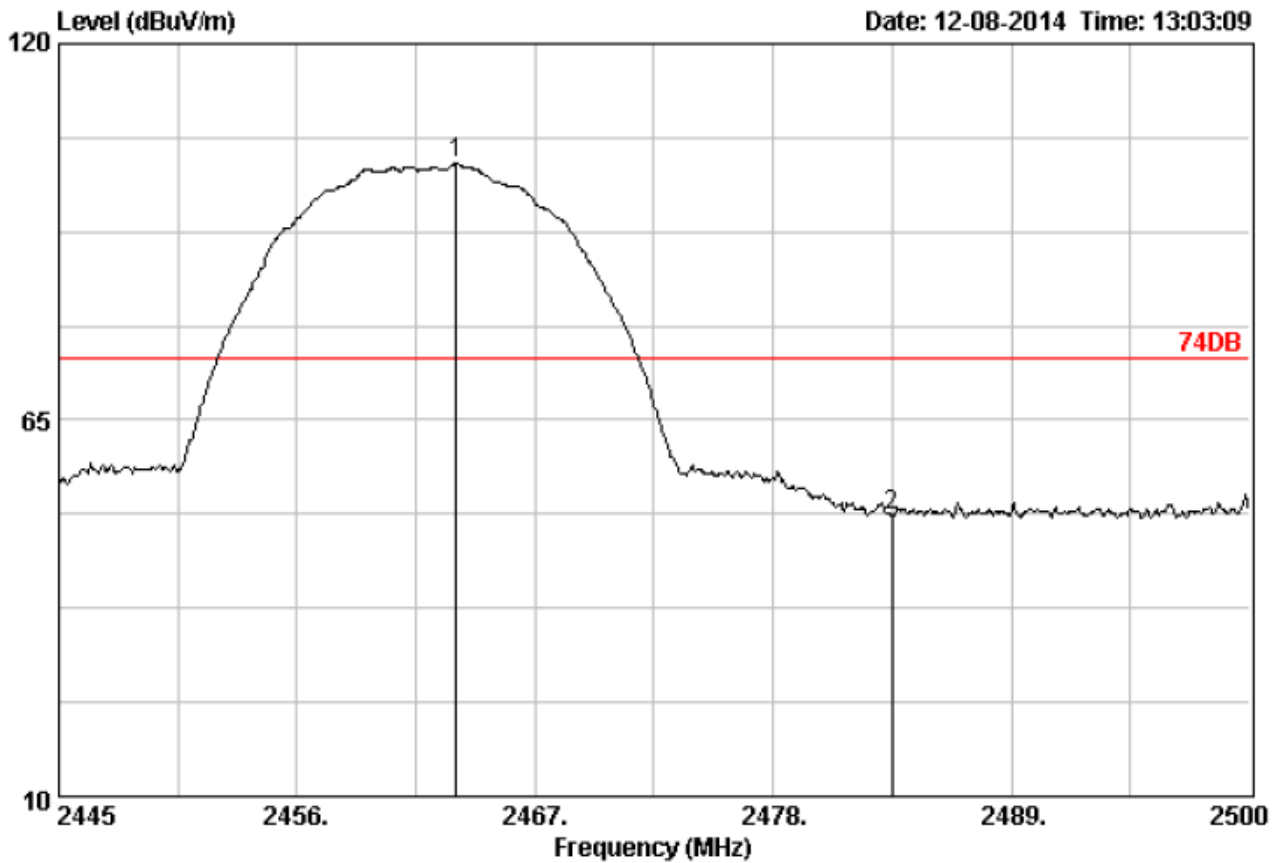

Site no. : 3m Chamber Data no. : 1176
 Dis. / Ant. : 3m DRH-118 Ant. pol. : HORIZONTAL
 Limit : 74DB
 Env. / Ins. : 23*C/54%
 Engineer :
 EUT :
 Power :
 M/N :
 Test Mode :

	Freq. (MHz)	Ant. Factor (dB)	Cable Loss (dB)	Reading (dBuV)	Emission Level (dBuV/m)	Limits (dBuV/m)	Margin (dB)	Remark
1	2463.37	28.90	4.68	104.23	102.44	74.00	-28.44	Peak
2	2483.50	28.93	4.70	52.82	51.07	74.00	22.93	Peak

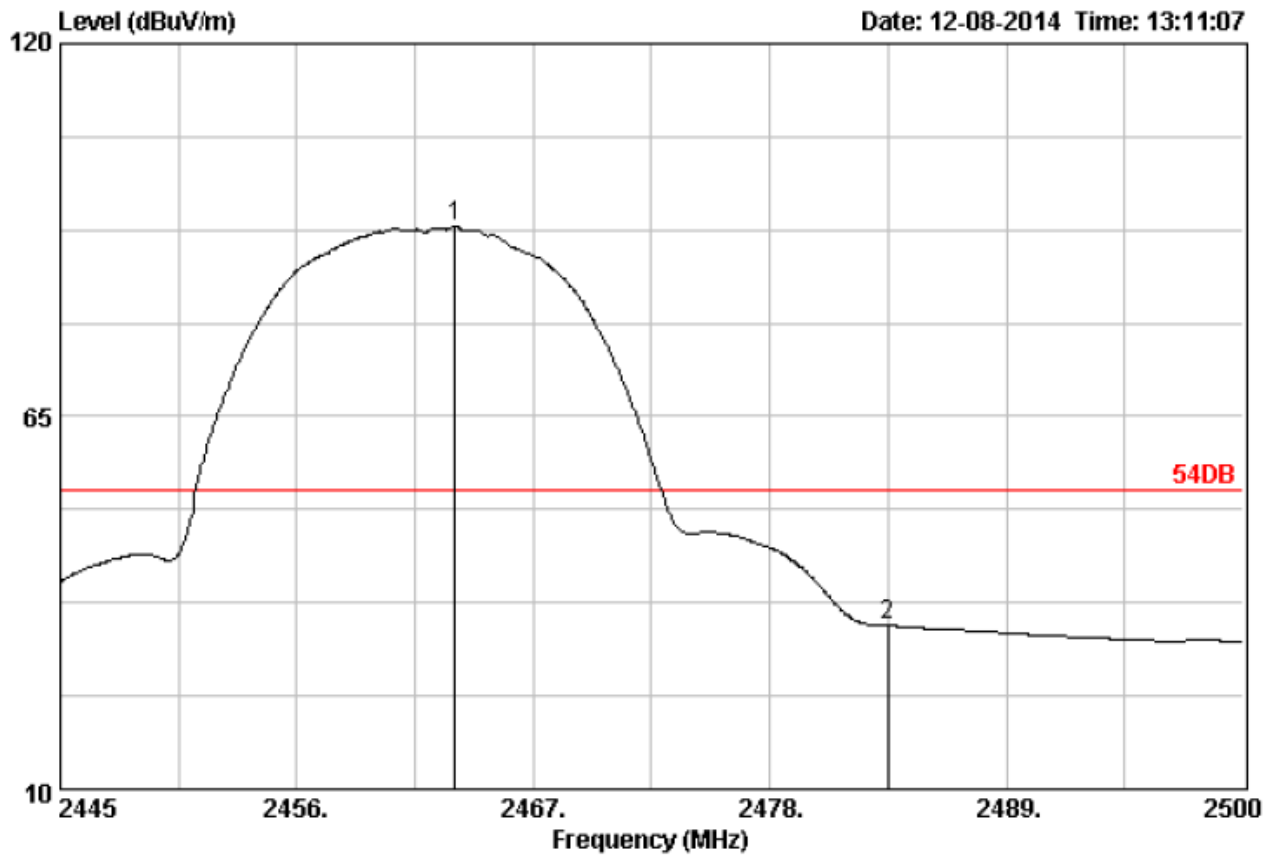

Site no. : 3m Chamber Data no. : 1178
 Dis. / Ant. : 3m DRH-118 Ant. pol. : HORIZONTAL
 Limit : 54DB
 Env. / Ins. : 23*C/54%
 Engineer :
 EUT :
 Power :
 M/N :
 Test Mode :

	Freq. (MHz)	Ant. Factor (dB)	Cable Loss (dB)	Emission Reading (dBuV)	Emission		Margin (dB)	Remark
					Level (dBuV/m)	Limits (dBuV/m)		
1	2463.37	28.90	4.68	94.86	93.07	54.00	-39.07	Average
2	2483.50	28.93	4.70	35.90	34.15	54.00	19.85	Average

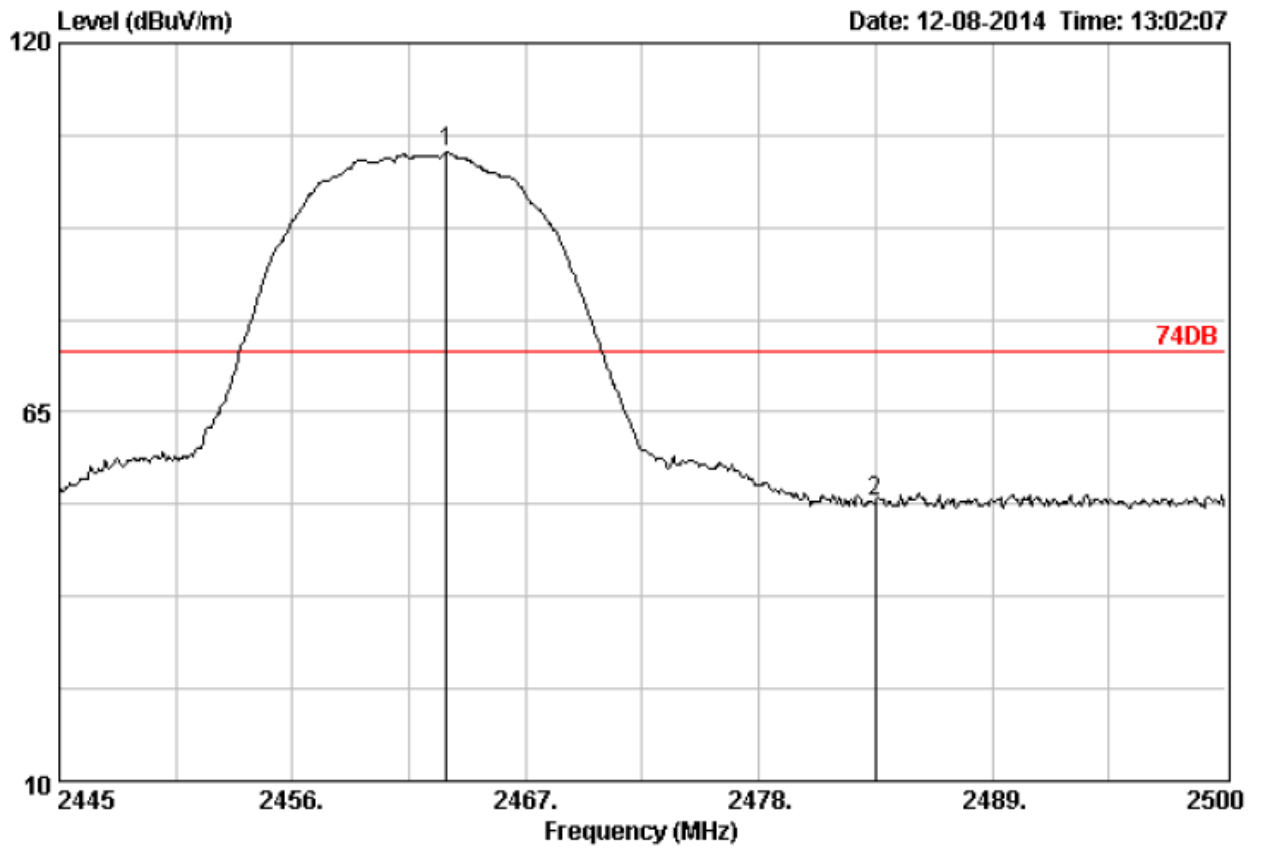

Site no. : 3m Chamber
 Dis. / Ant. : 3m DRH-118
 Limit : 74DB
 Env. / Ins. : 23°C/54%
 Engineer :
 EUT :
 Power :
 M/N :
 Test Mode :
 Data no. : 1175
 Ant. pol. : VERTICAL

	Freq. (MHz)	Ant. Factor (dB)	Cable Loss (dB)	Reading (dBuV)	Emission			Remark
					Level (dBuV/m)	Limits (dBuV/m)	Margin (dB)	
1	2463.26	28.90	4.68	105.42	103.63	74.00	-29.63	Peak
2	2483.50	28.93	4.70	53.40	51.65	74.00	22.35	Peak

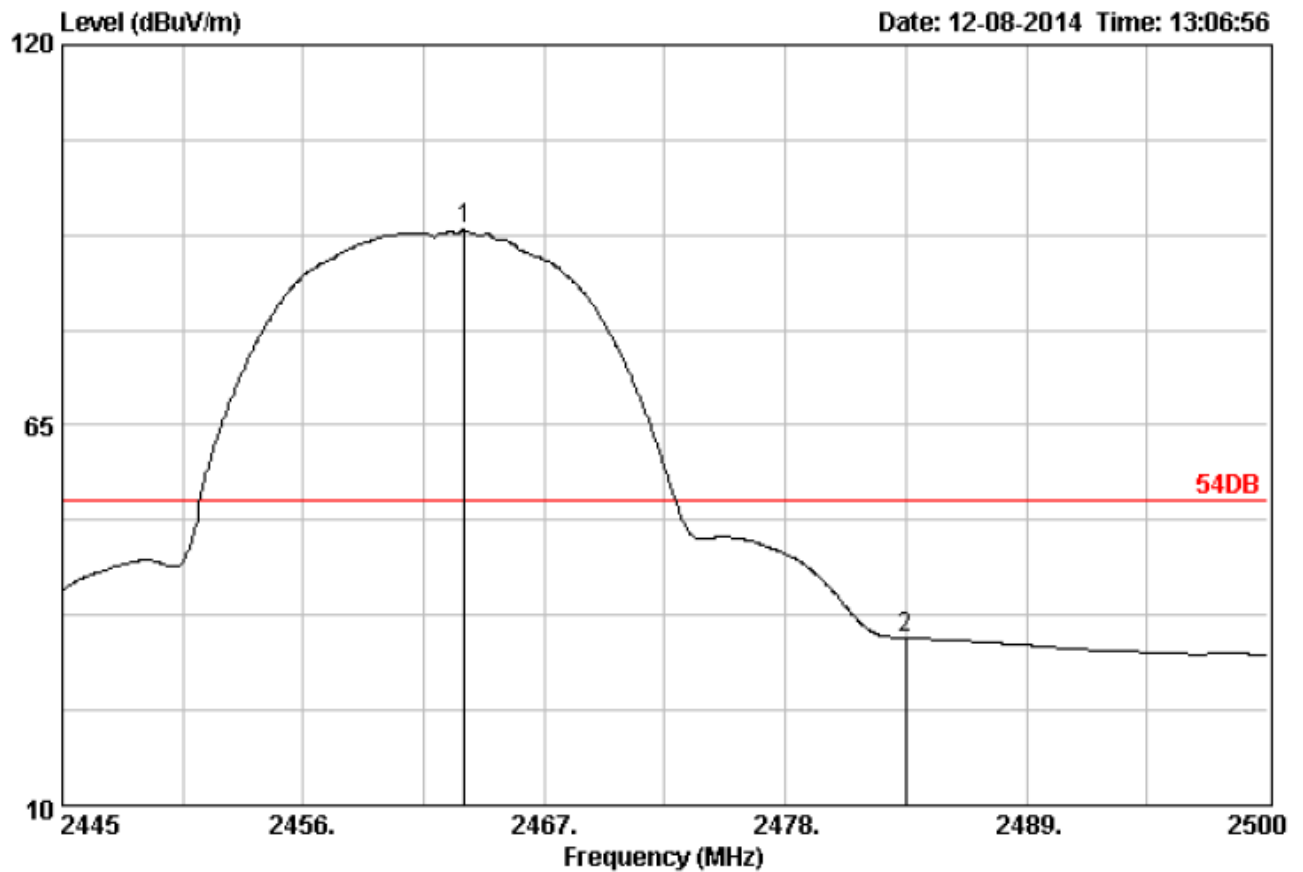

Site no. : 3m Chamber
 Dis. / Ant. : 3m DRH-118
 Limit : 54DB
 Env. / Ins. : 23*C/54%
 Engineer :
 EUT :
 Power :
 M/N :
 Test Mode :
 Data no. : 1177
 Ant. pol. : VERTICAL

	Freq. (MHz)	Ant. Factor (dB)	Cable Loss (dB)	Reading (dBuV)	Emission		Margin (dB)	Remark
					Level (dBuV/m)	Limits (dBuV/m)		
1	2463.37	28.90	4.68	95.05	93.26	54.00	-39.26	Average
2	2483.50	28.93	4.70	35.99	34.24	54.00	19.76	Average

For 802.11g Mode:

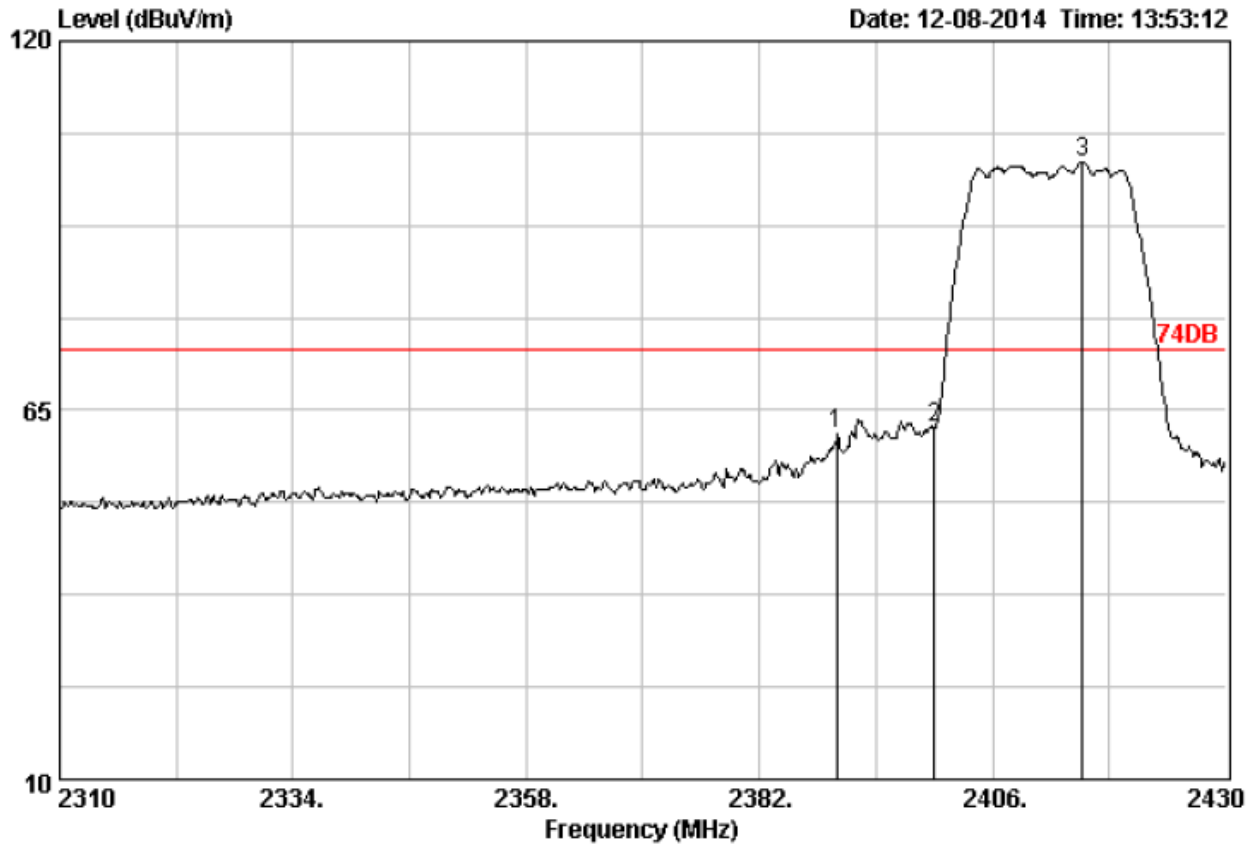

Site no. : 3m Chamber
 Dis. / Ant. : 3m DRH-118
 Limit : 74DB
 Env. / Ins. : 23*C/54%
 Engineer :
 EUT :
 Power :
 M/N :
 Test Mode :

Data no. : 1180
 Ant. pol. : HORIZONTAL

	Freq. (MHz)	Ant. Factor (dB)	Cable Loss (dB)	Reading (dBuV)	Emission			Remark
					Level (dBuV/m)	Limits (dBuV/m)	Margin (dB)	
1	2390.00	28.78	4.61	63.49	61.52	74.00	12.48	Peak
2	2400.00	28.78	4.61	64.30	62.33	74.00	11.67	Peak
3	2415.24	28.81	4.63	103.78	101.86	74.00	-27.86	Peak

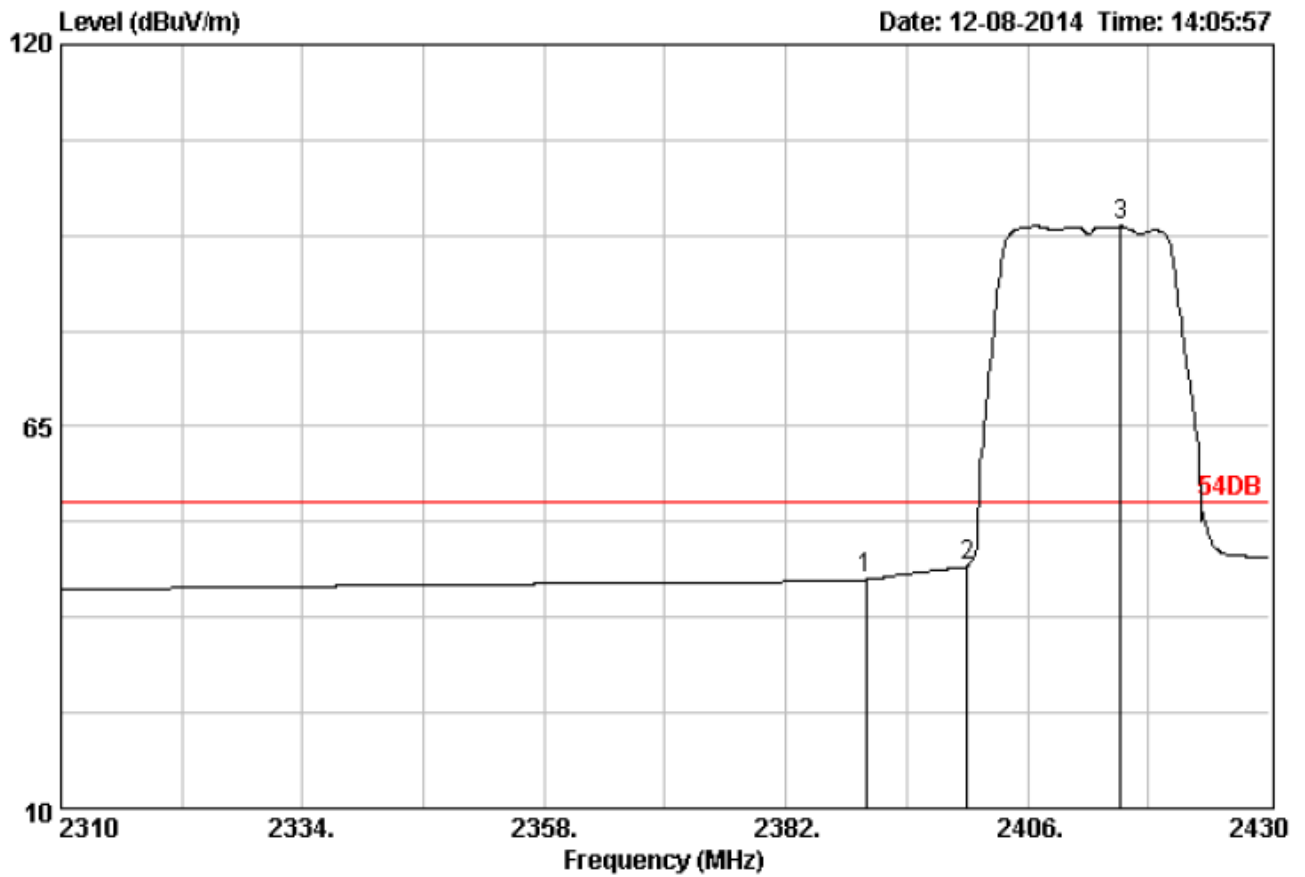

Site no. : 3m Chamber Data no. : 1182
 Dis. / Ant. : 3m DRH-118 Ant. pol. : HORIZONTAL
 Limit : 54DB
 Env. / Ins. : 23*C/54%
 Engineer :
 EUT :
 Power :
 M/N :
 Test Mode :

	Freq. (MHz)	Ant. Factor (dB)	Cable Loss (dB)	Emission		Margin (dB)	Remark	
				Reading (dBuV)	Level (dBuV/m)			
1	2390.00	28.78	4.61	44.92	42.95	54.00	11.05	Average
2	2400.00	28.78	4.61	46.90	44.93	54.00	9.07	Average
3	2415.24	28.81	4.63	95.77	93.85	54.00	-39.85	Average

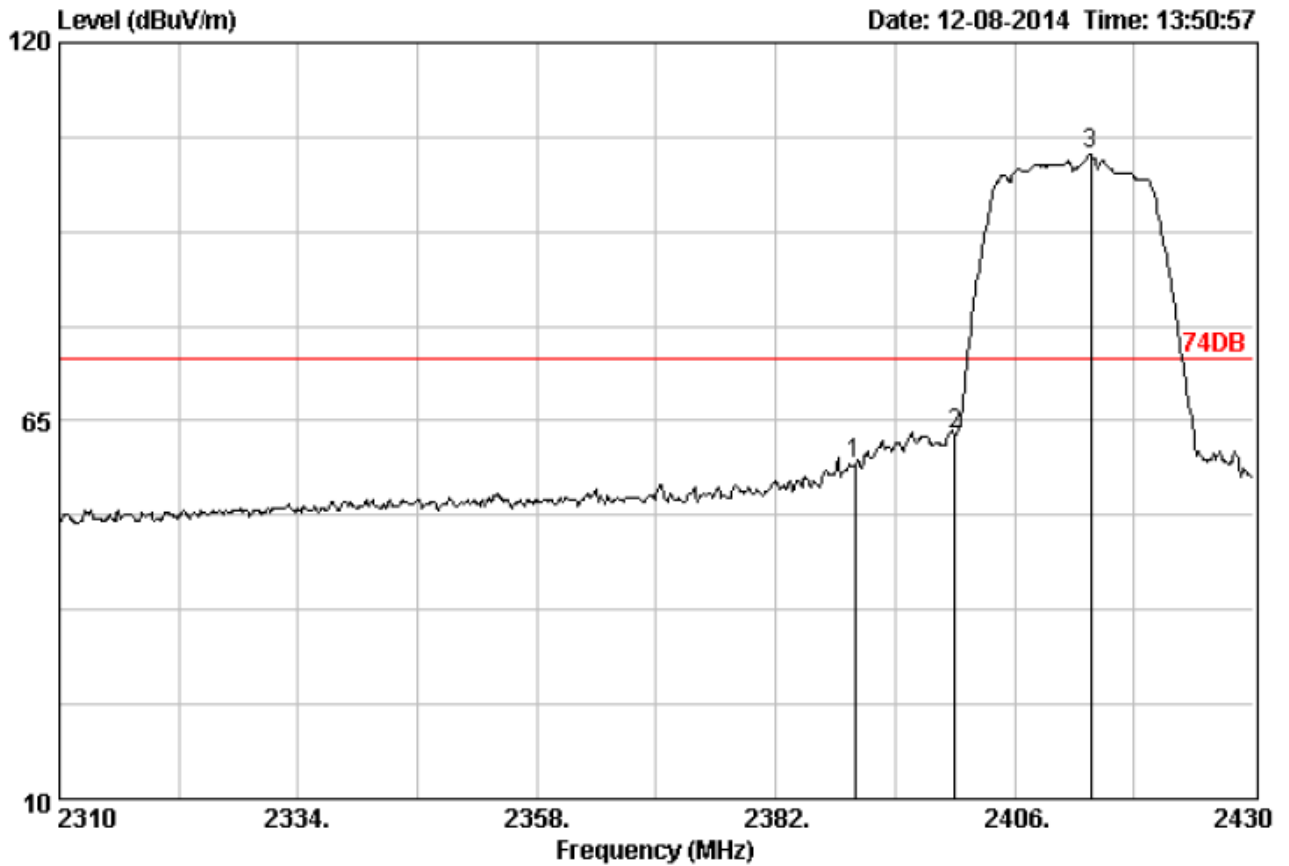

Site no. : 3m Chamber Data no. : 1179
 Dis. / Ant. : 3m DRH-118 Ant. pol. : VERTICAL
 Limit : 74DB
 Env. / Ins. : 23*C/54%
 Engineer :
 EUT :
 Power :
 M/N :
 Test Mode :

	Freq. (MHz)	Ant. Factor (dB)	Cable Loss (dB)	Reading (dBuV)	Emission			Remark
					Level (dBuV/m)	Limits (dBuV/m)	Margin (dB)	
1	2390.00	28.78	4.61	60.59	58.62	74.00	15.38	Peak
2	2400.00	28.78	4.61	65.04	63.07	74.00	10.93	Peak
3	2413.68	28.81	4.63	105.76	103.84	74.00	-29.84	Peak

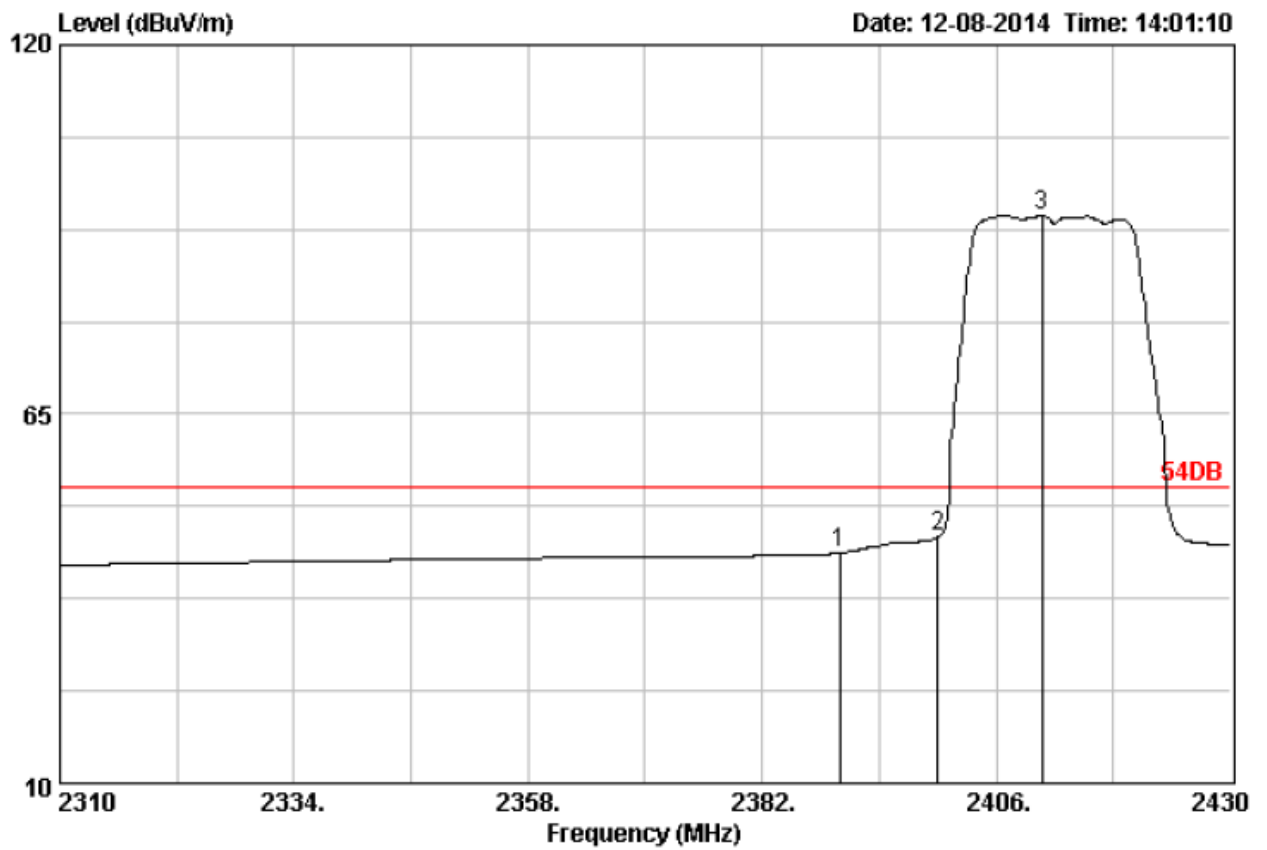

Site no. : 3m Chamber Data no. : 1181
 Dis. / Ant. : 3m DRH-118 Ant. pol. : VERTICAL
 Limit : 54DB
 Env. / Ins. : 23*C/54%
 Engineer :
 EUT :
 Power :
 M/N :
 Test Mode :

	Freq. (MHz)	Ant. Factor (dB)	Cable Loss (dB)	Emission Reading (dBuV)	Emission Level (dBuV/m)	Limits (dBuV/m)	Margin (dB)	Remark
1	2390.00	28.78	4.61	46.34	44.37	54.00	9.63	Average
2	2400.00	28.78	4.61	48.61	46.64	54.00	7.36	Average
3	2410.68	28.81	4.63	96.51	94.59	54.00	-40.59	Average

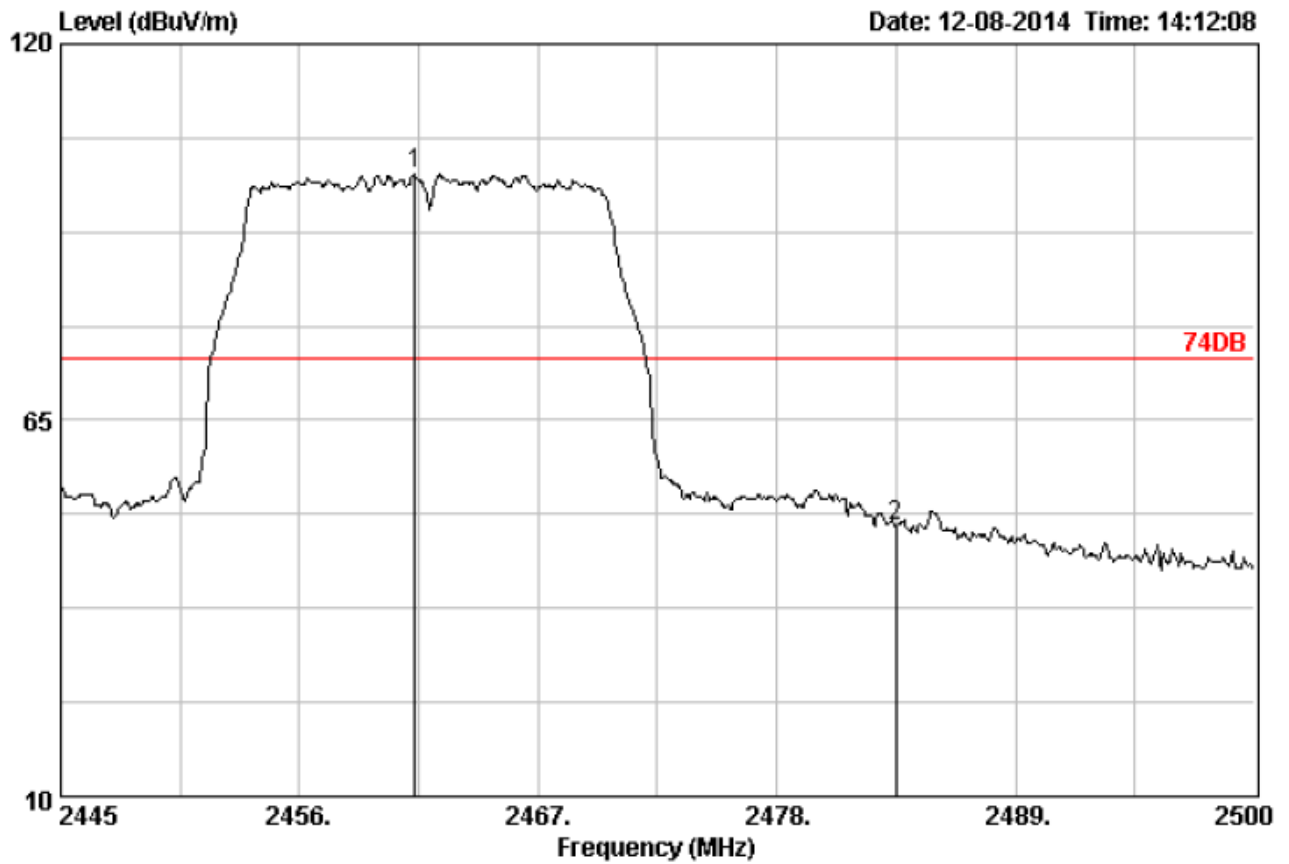

Site no. : 3m Chamber Data no. : 1184
 Dis. / Ant. : 3m DRH-118 Ant. pol. : HORIZONTAL
 Limit : 74DB
 Env. / Ins. : 23*C/54%
 Engineer :
 EUT :
 Power :
 M/N :
 Test Mode :

	Freq. (MHz)	Ant. Factor (dB)	Cable Loss (dB)	Reading (dBuV)	Emission Level (dBuV/m)	Limits (dBuV/m)	Margin (dB)	Remark
1	2461.34	28.90	4.68	102.69	100.90	74.00	-26.90	Peak
2	2483.50	28.93	4.70	51.28	49.53	74.00	24.47	Peak

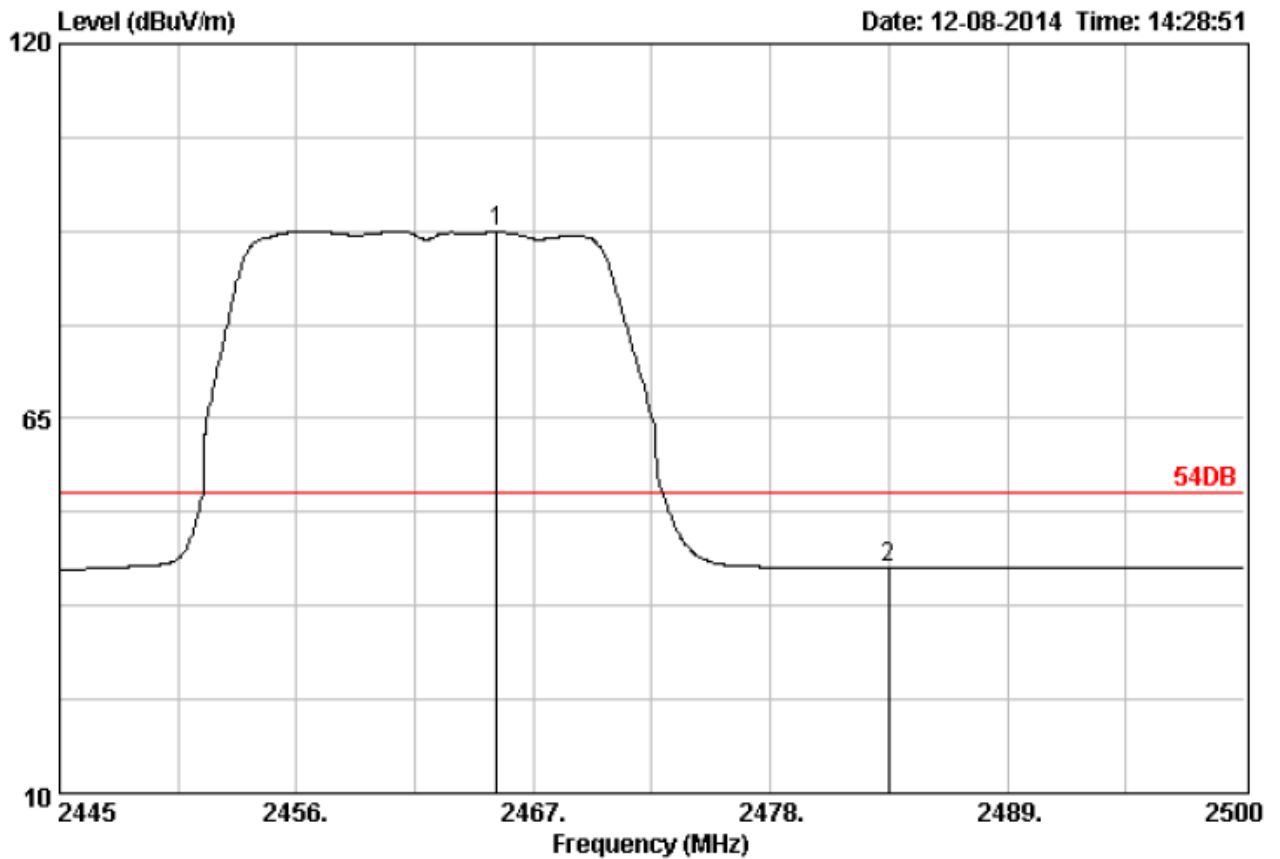

Site no. : 3m Chamber Data no. : 1186
 Dis. / Ant. : 3m DRH-118 Ant. pol. : HORIZONTAL
 Limit : 54DB
 Env. / Ins. : 23*C/54%
 Engineer :
 EUT :
 Power :
 M/N :
 Test Mode :

	Freq. (MHz)	Ant. Factor (dB)	Cable Loss (dB)	Reading (dBuV)	Emission Level (dBuV/m)	Limits (dBuV/m)	Margin (dB)	Remark
1	2465.30	28.90	4.68	94.25	92.46	54.00	-38.46	Average
2	2483.50	28.93	4.70	44.78	43.03	54.00	10.97	Average

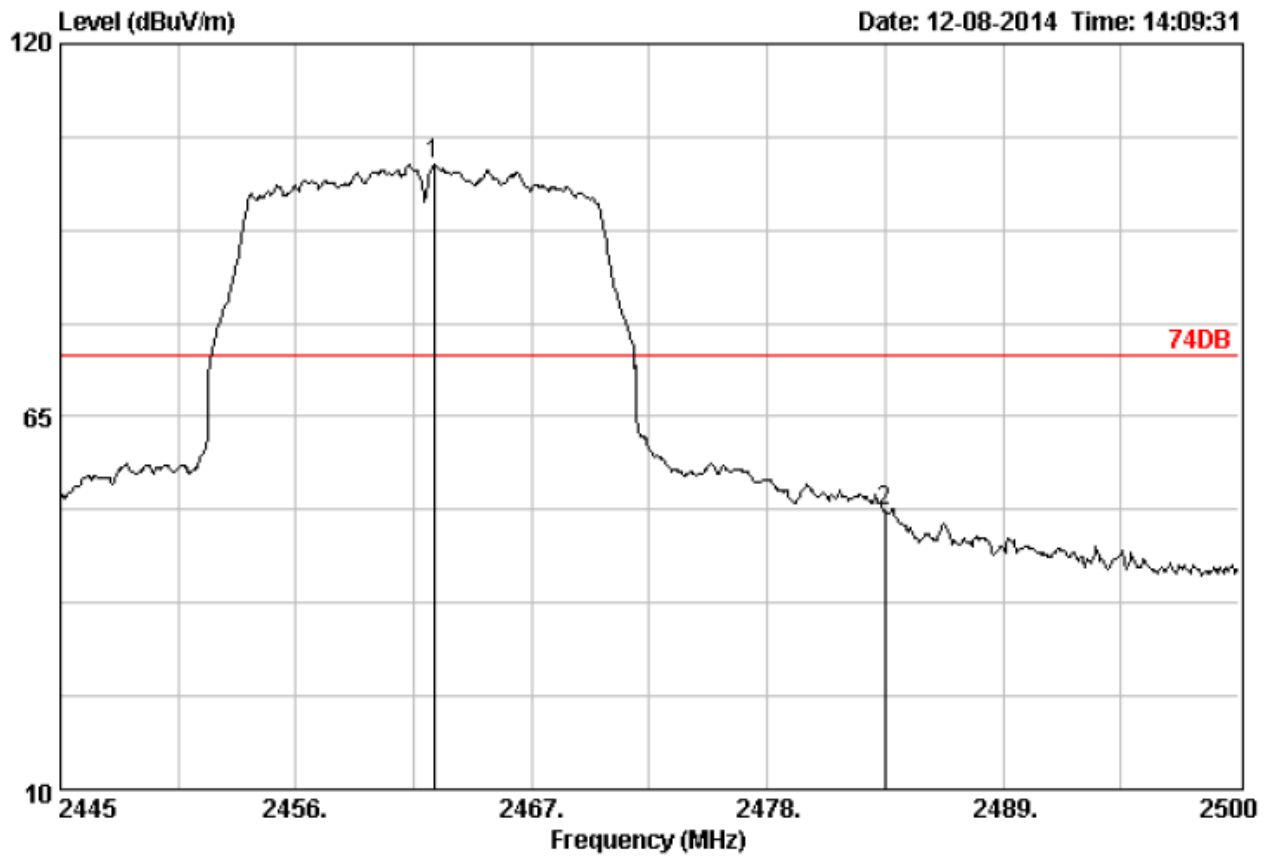

Site no. : 3m Chamber
 Dis. / Ant. : 3m DRH-118
 Limit : 74DB
 Env. / Ins. : 23°C/54%
 Engineer :
 EUT :
 Power :
 M/N :
 Test Mode :

Data no. : 1183
 Ant. pol. : VERTICAL

	Freq. (MHz)	Ant. Factor (dB)	Cable Loss (dB)	Emission				Remark
				Reading (dBuV)	Level (dBuV/m)	Limits (dBuV/m)	Margin (dB)	
1	2462.44	28.90	4.68	104.00	102.21	74.00	-28.21	Peak
2	2483.50	28.93	4.70	52.69	50.94	74.00	23.06	Peak

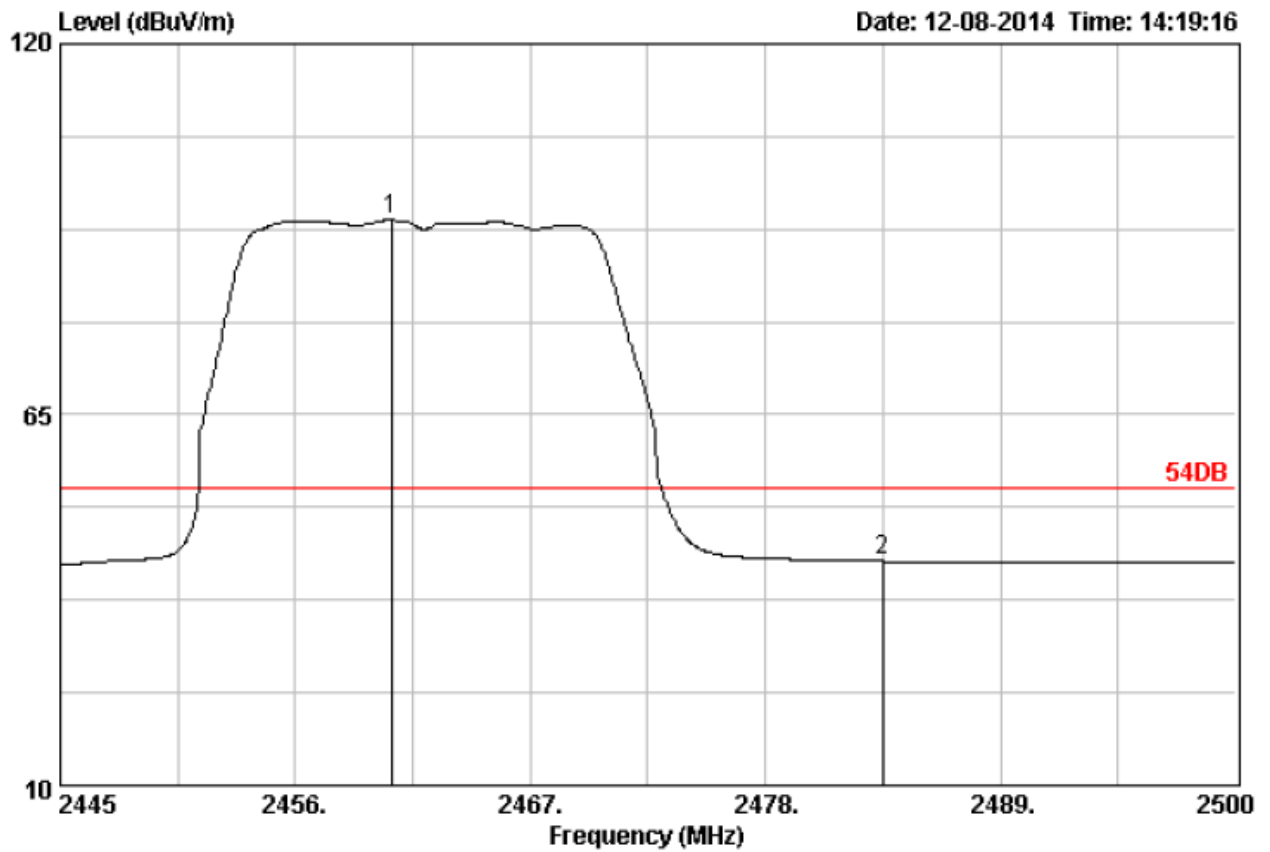

Site no. : 3m Chamber
 Dis. / Ant. : 3m DRH-118
 Limit : 54DB
 Env. / Ins. : 23*C/54%
 Engineer :
 EUT :
 Power :
 M/N :
 Test Mode :

Data no. : 1185
 Ant. pol. : VERTICAL

	Freq. (MHz)	Ant. Factor (dB)	Cable Loss (dB)	Reading (dBuV)	Emission Level (dBuV/m)	Limits (dBuV/m)	Margin (dB)	Remark
1	2460.51	28.90	4.68	95.66	93.87	54.00	-39.87	Average
2	2483.50	28.93	4.70	45.00	43.25	54.00	10.75	Average

Note : For 802.11n (20MHz) Mode:

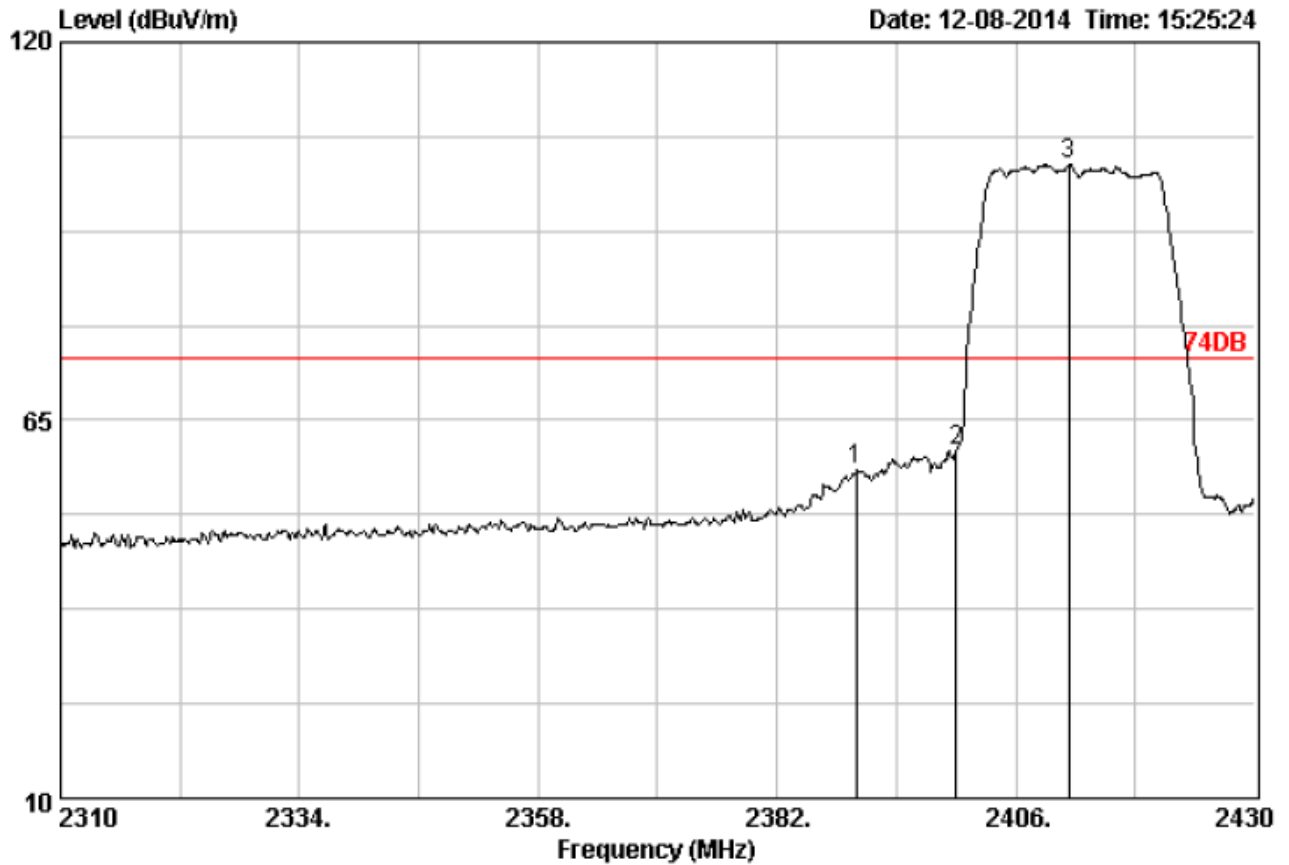

Site no. : 3m Chamber Data no. : 1188
 Dis. / Ant. : 3m DRH-118 Ant. pol. : HORIZONTAL
 Limit : 74DB
 Env. / Ins. : 23°C/54%
 Engineer :
 EUT :
 Power :
 M/N :
 Test Mode :

	Freq. (MHz)	Ant. Factor (dB)	Cable Loss (dB)	Reading (dBUV)	Emission Level (dBUV/m)	Limits (dBUV/m)	Margin (dB)	Remark
1	2390.00	28.78	4.61	59.74	57.77	74.00	16.23	Peak
2	2400.00	28.78	4.61	62.55	60.58	74.00	13.42	Peak
3	2411.28	28.81	4.63	104.05	102.13	74.00	-28.13	Peak

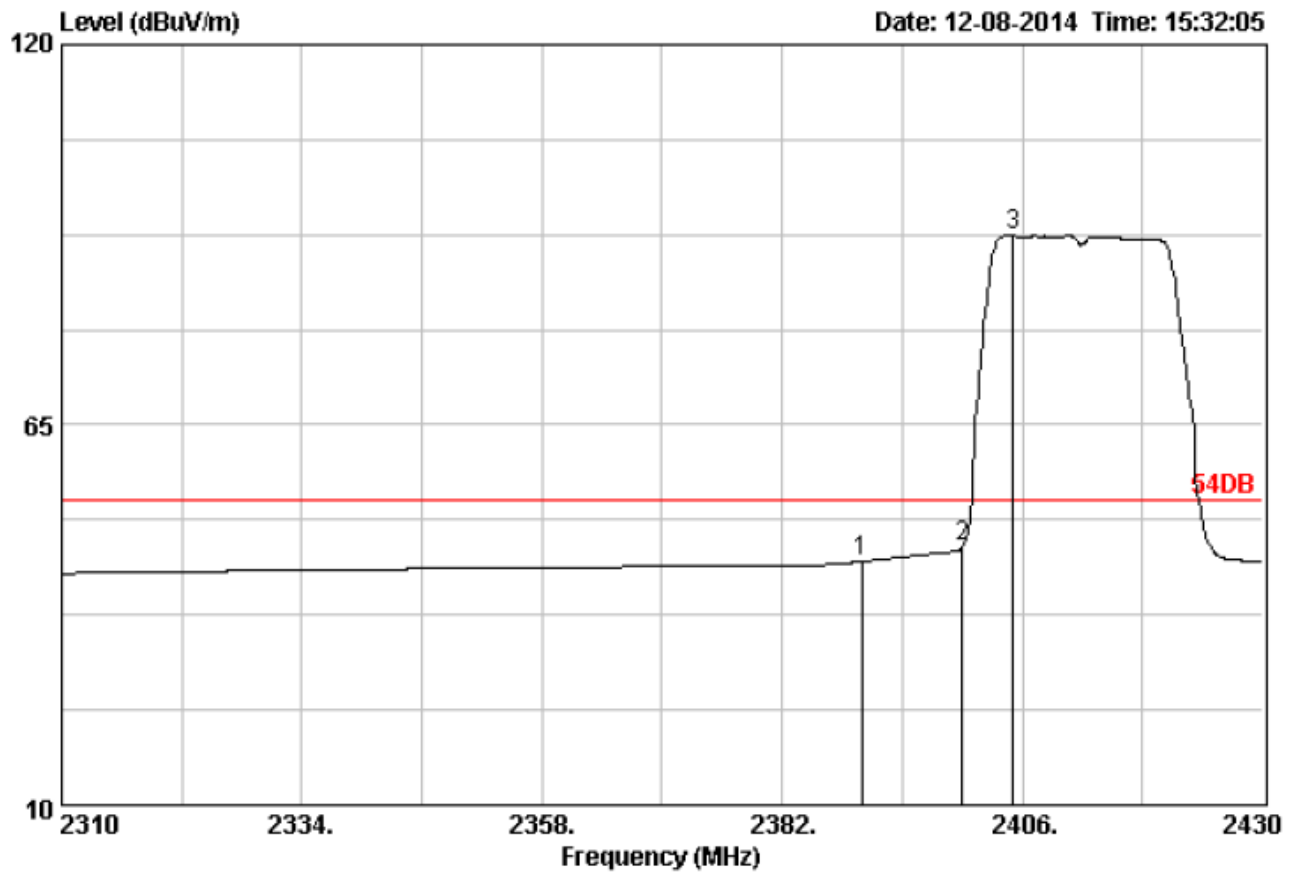

Site no. : 3m Chamber Data no. : 1190
 Dis. / Ant. : 3m DRH-118 Ant. pol. : HORIZONTAL
 Limit : 54DB
 Env. / Ins. : 23°C/54%
 Engineer :
 EUT :
 Power :
 M/N :
 Test Mode :

	Freq. (MHz)	Ant. Factor (dB)	Cable Loss (dB)	Emission Reading (dBuV)	Emission Level (dBuV/m)	Limits (dBuV/m)	Margin (dB)	Remark
1	2390.00	28.78	4.61	47.24	45.27	54.00	8.73	Average
2	2400.00	28.78	4.61	49.34	47.37	54.00	6.63	Average
3	2405.04	28.81	4.63	94.31	92.39	54.00	-38.39	Average

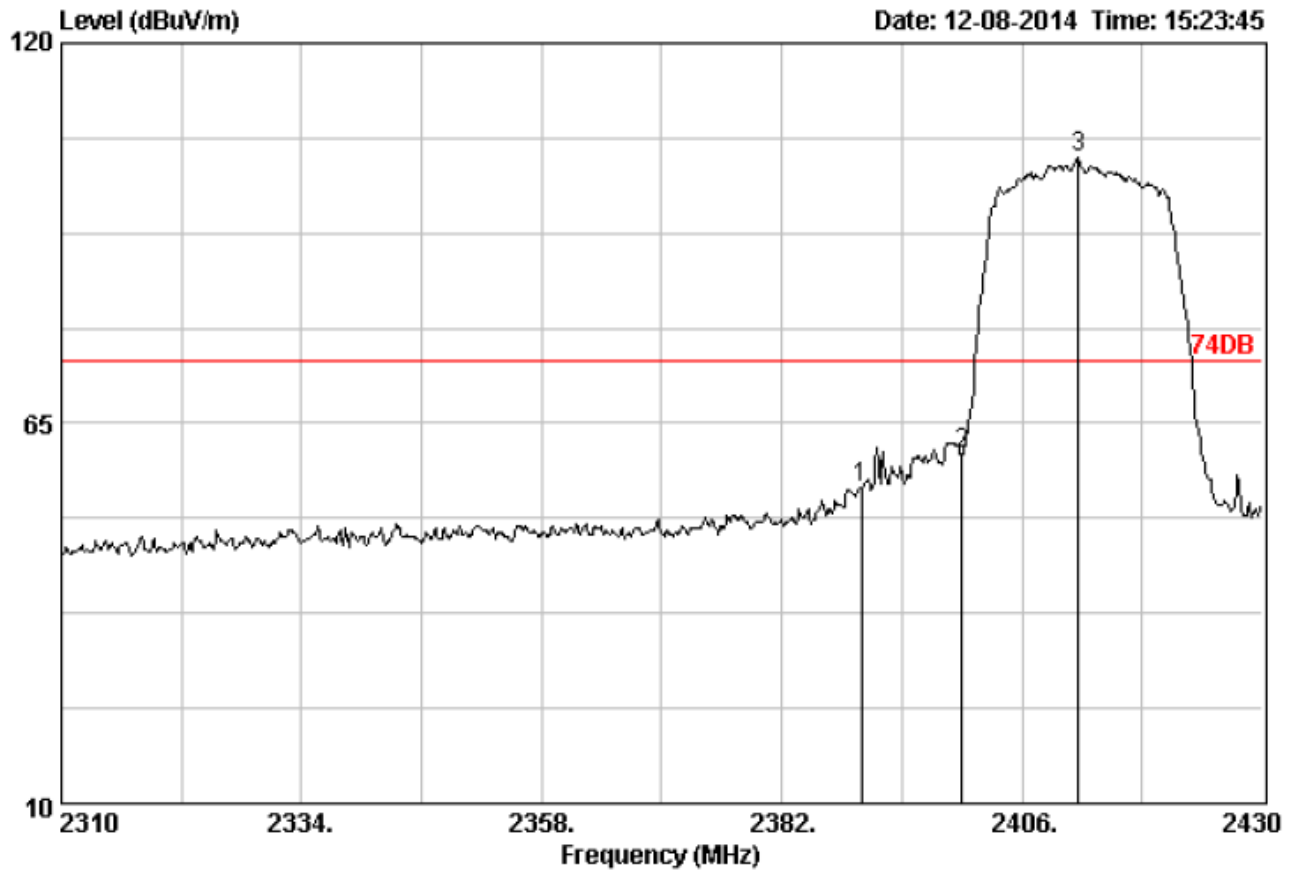

Site no. : 3m Chamber Data no. : 1187
 Dis. / Ant. : 3m DRH-118 Ant. pol. : VERTICAL
 Limit : 74DB
 Env. / Ins. : 23°C/54%
 Engineer :
 EUT :
 Power :
 M/N :
 Test Mode :

	Freq. (MHz)	Ant. Factor (dB)	Cable Loss (dB)	Reading (dBuV)	Emission Level (dBuV/m)	Limits (dBuV/m)	Margin (dB)	Remark
1	2390.00	28.78	4.61	57.65	55.68	74.00	18.32	Peak
2	2400.00	28.78	4.61	62.43	60.46	74.00	13.54	Peak
3	2411.64	28.81	4.63	105.33	103.41	74.00	-29.41	Peak

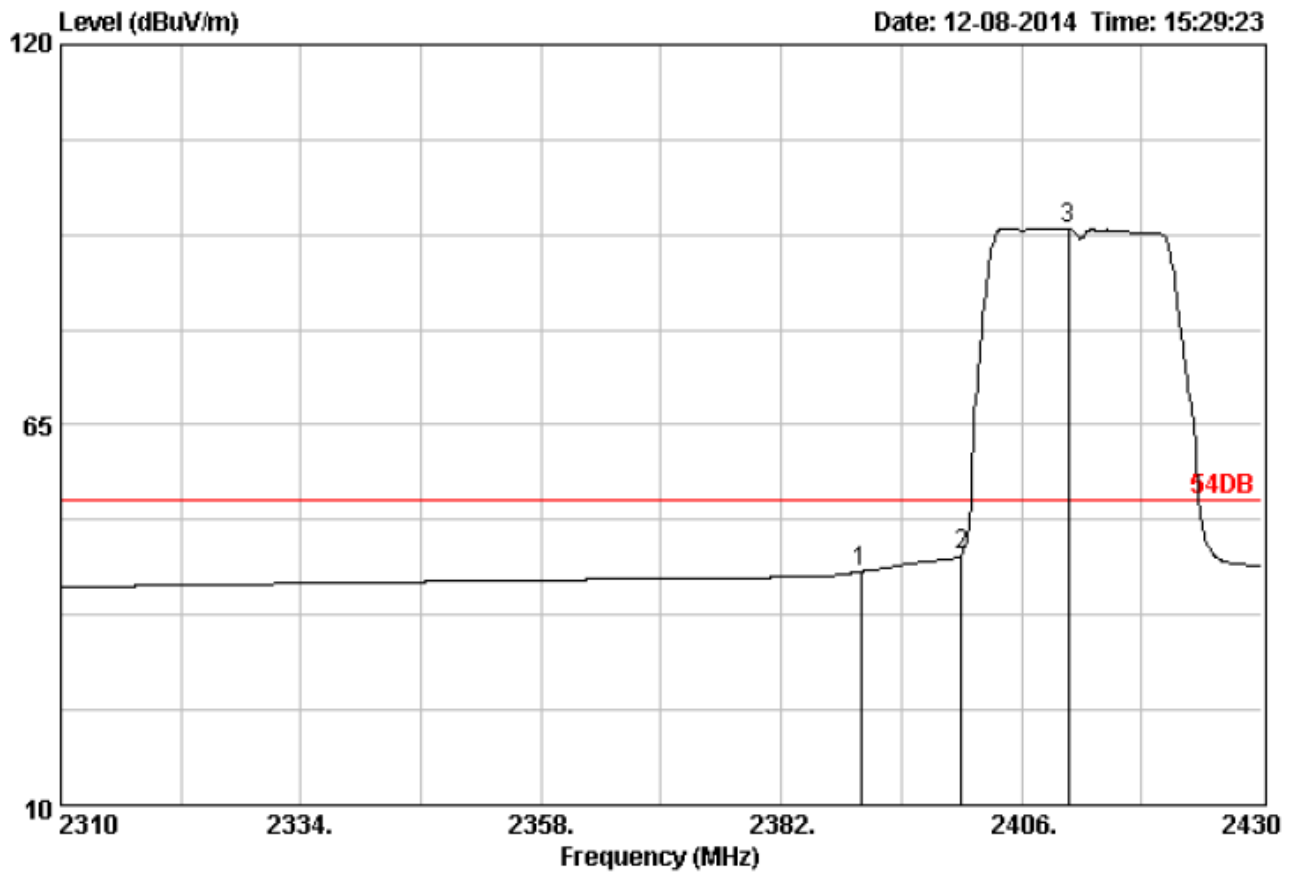

Site no. : 3m Chamber Data no. : 1189
 Dis. / Ant. : 3m DRH-118 Ant. pol. : VERTICAL
 Limit : 54DB
 Env. / Ins. : 23*C/54%
 Engineer :
 EUT :
 Power :
 M/N :
 Test Mode :

	Freq. (MHz)	Ant. Factor (dB)	Cable Loss (dB)	Reading (dBuV)	Emission			Remark
					Level (dBuV/m)	Limits (dBuV/m)	Margin (dB)	
1	2390.00	28.78	4.61	45.77	43.80	54.00	10.20	Average
2	2400.00	28.78	4.61	48.28	46.31	54.00	7.69	Average
3	2410.68	28.81	4.63	95.33	93.41	54.00	-39.41	Average

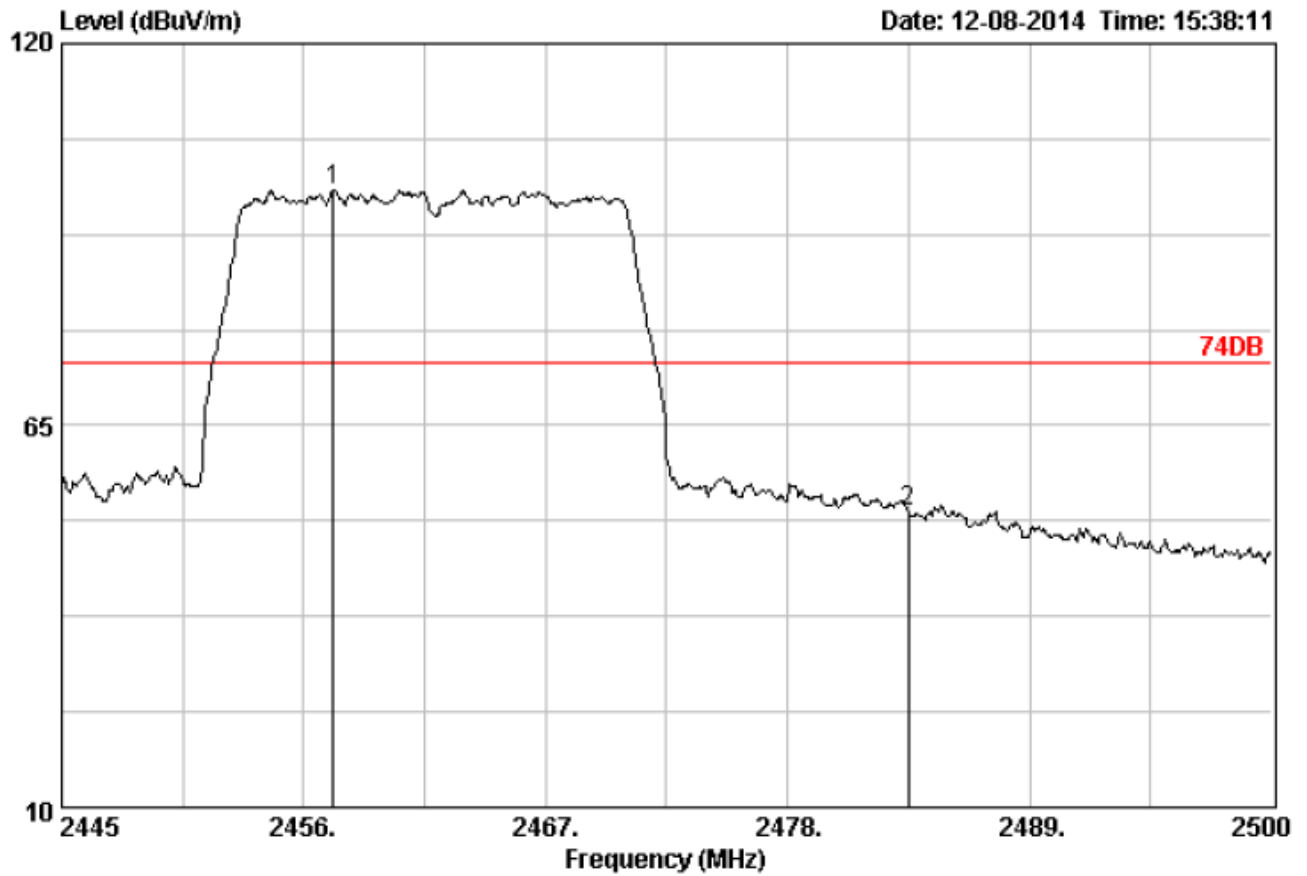

Site no. : 3m Chamber Data no. : 1193
 Dis. / Ant. : 3m DRH-118 Ant. pol. : HORIZONTAL
 Limit : 74DB
 Env. / Ins. : 23*C/54%
 Engineer :
 EUT :
 Power :
 M/N :
 Test Mode :

	Freq. (MHz)	Ant. Factor (dB)	Cable Loss (dB)	Reading (dBuV)	Emission Level (dBuV/m)	Limits (dBuV/m)	Margin (dB)	Remark
1	2457.32	28.90	4.68	100.63	98.84	74.00	-24.84	Peak
2	2483.50	28.93	4.70	54.46	52.71	74.00	21.29	Peak

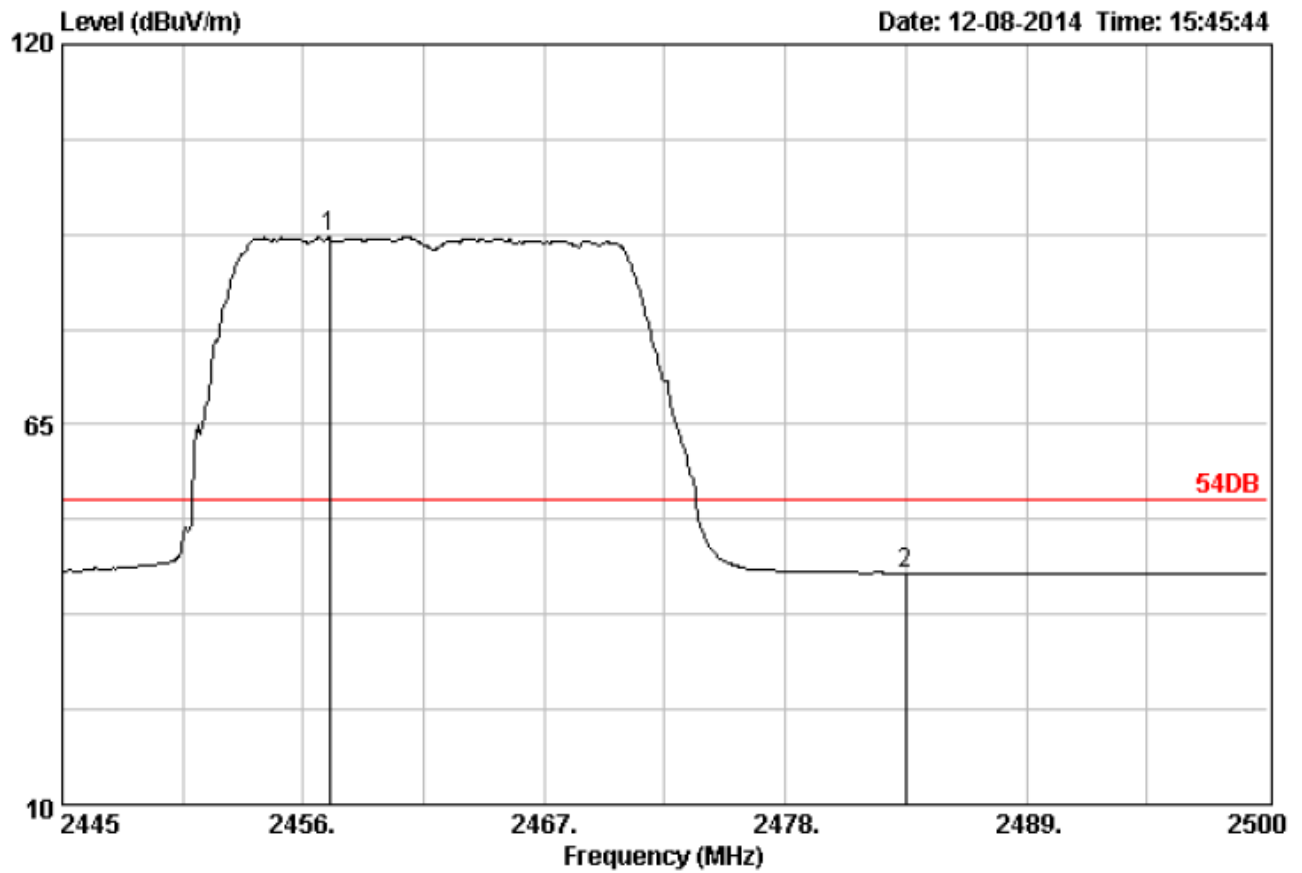

Site no. : 3m Chamber Data no. : 1195
 Dis. / Ant. : 3m DRH-118 Ant. pol. : HORIZONTAL
 Limit : 54DB
 Env. / Ins. : 23°C/54%
 Engineer :
 EUT :
 Power :
 M/N :
 Test Mode :

	Freq. (MHz)	Ant. Factor (dB)	Cable Loss (dB)	Reading (dBuV)	Emission Level (dBuV/m)	Limits (dBuV/m)	Margin (dB)	Remark
1	2457.21	28.90	4.68	93.88	92.09	54.00	-38.09	Average
2	2483.50	28.93	4.70	45.23	43.48	54.00	10.52	Average

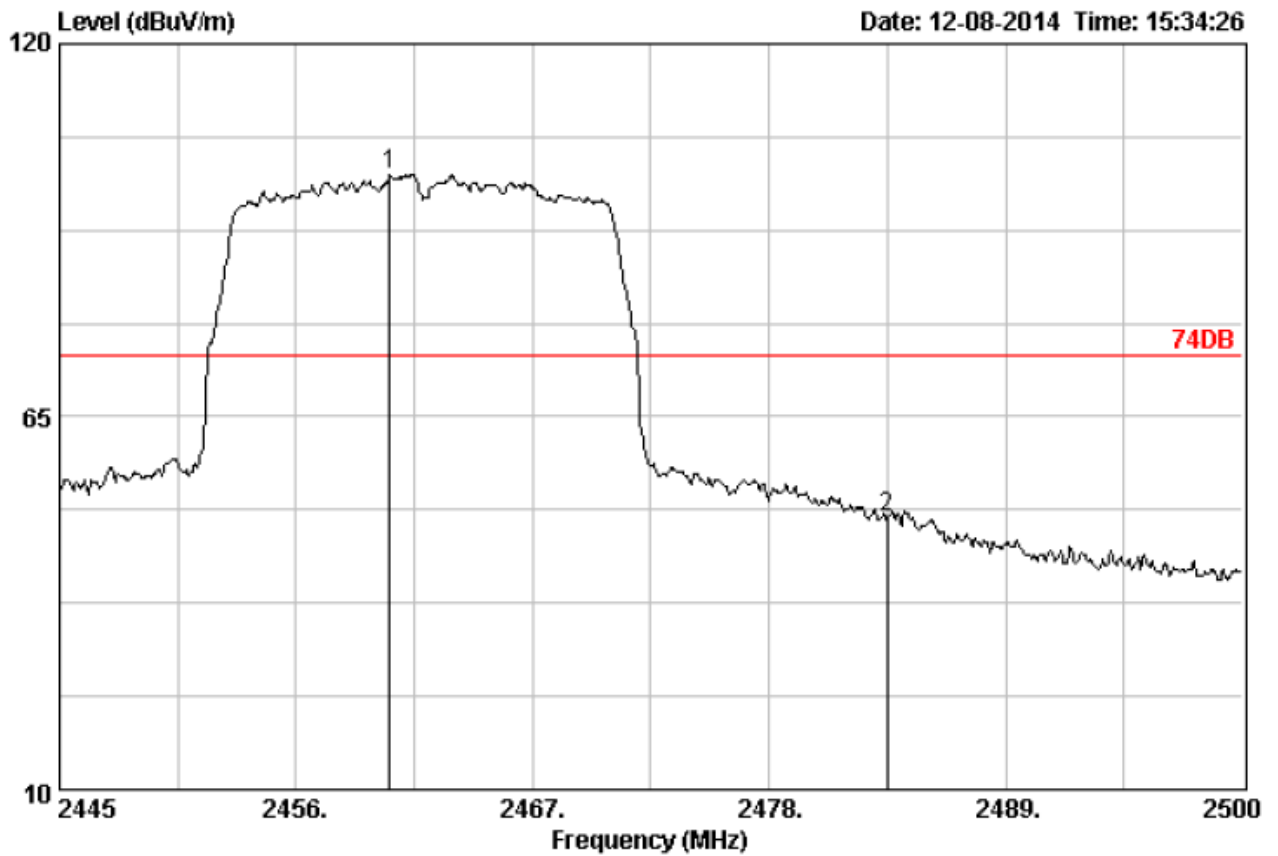

Site no. : 3m Chamber
 Dis. / Ant. : 3m DRH-118
 Limit : 74DB
 Env. / Ins. : 23*C/54%
 Engineer :
 EUT :
 Power :
 M/N :
 Test Mode :

Data no. : 1191
 Ant. pol. : VERTICAL

	Freq. (MHz)	Ant. Factor (dB)	Cable Loss (dB)	Reading (dBuV)	Emission Level (dBuV/m)	Limits (dBuV/m)	Margin (dB)	Remark
1	2460.35	28.90	4.68	102.55	100.76	74.00	-26.76	Peak
2	2483.50	28.93	4.70	51.77	50.02	74.00	23.98	Peak

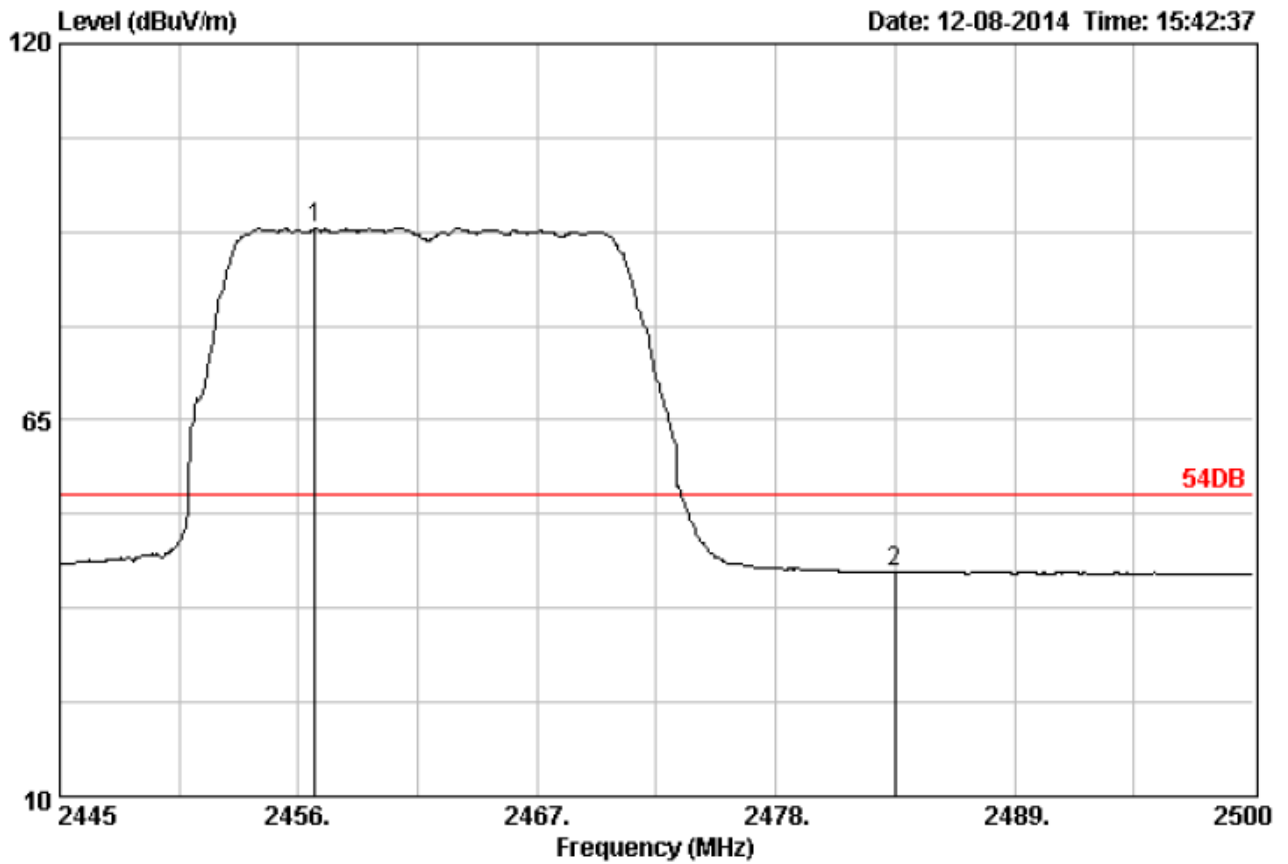

Site no. : 3m Chamber Data no. : 1194
 Dis. / Ant. : 3m DRH-118 Ant. pol. : VERTICAL
 Limit : 54DB
 Env. / Ins. : 23°C/54%
 Engineer :
 EUT :
 Power :
 M/N :
 Test Mode :

	Freq. (MHz)	Ant. Factor (dB)	Cable Loss (dB)	Emission				Remark
				Reading (dBuV)	Level (dBuV/m)	Limits (dBuV/m)	Margin (dB)	
1	2456.77	28.90	4.68	94.88	93.09	54.00	-39.09	Average
2	2483.50	28.93	4.70	44.56	42.81	54.00	11.19	Average

4.6. Power Spectral Density Measurement

TEST CONFIGURATION

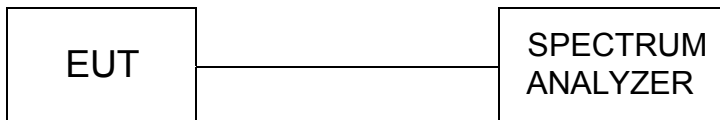

TEST PROCEDURE

The EUT was tested according to KDB558074 D01 v03r02 for compliance to FCC 47CFR 15.247 requirements. Set RBW= 3 kHz, VBW ≥ 10KHz, SPAN to 1.5 times greater than the EBW,.

LIMIT

For digitally modulated systems, the power spectral density conducted from the intentional radiator to the antenna shall not be greater than 8 dBm in any 3 kHz band during any time interval of continuous transmission.

TEST RESULTS

Product	:	Enjoy TV
Test Item	:	Power Spectral Density
Test Mode	:	Mode 1: Transmit by 802.11b

Channel No.	Frequency (MHz)	Measurement PPSD (dBm/3KHz)	Limit (dBm/3KHz)	Result
01	2412	-5.36	8	Pass
06	2437	-6.45	8	Pass
11	2462	-5.87	8	Pass

Channel 01 (2412MHz)

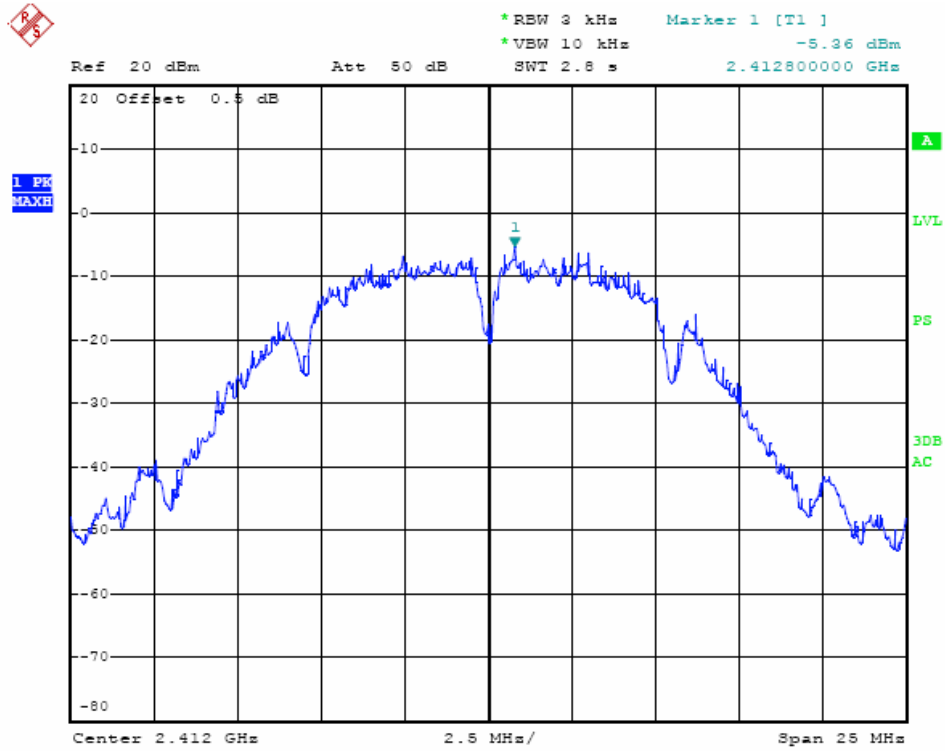

Channel 06 (2437MHz)

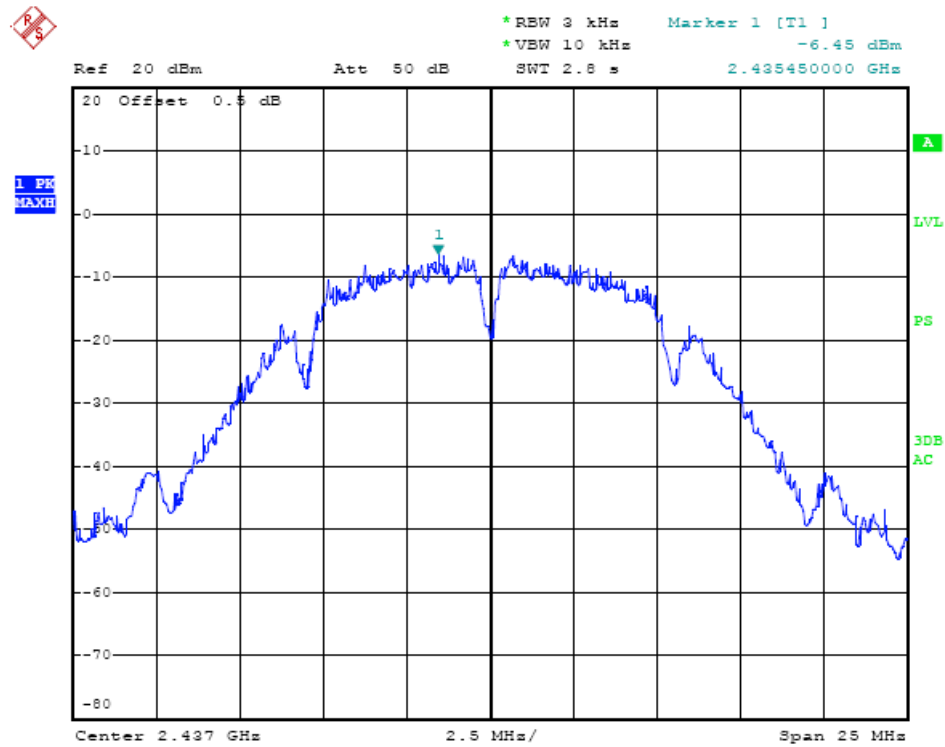

Channel 11 (2462MHz)

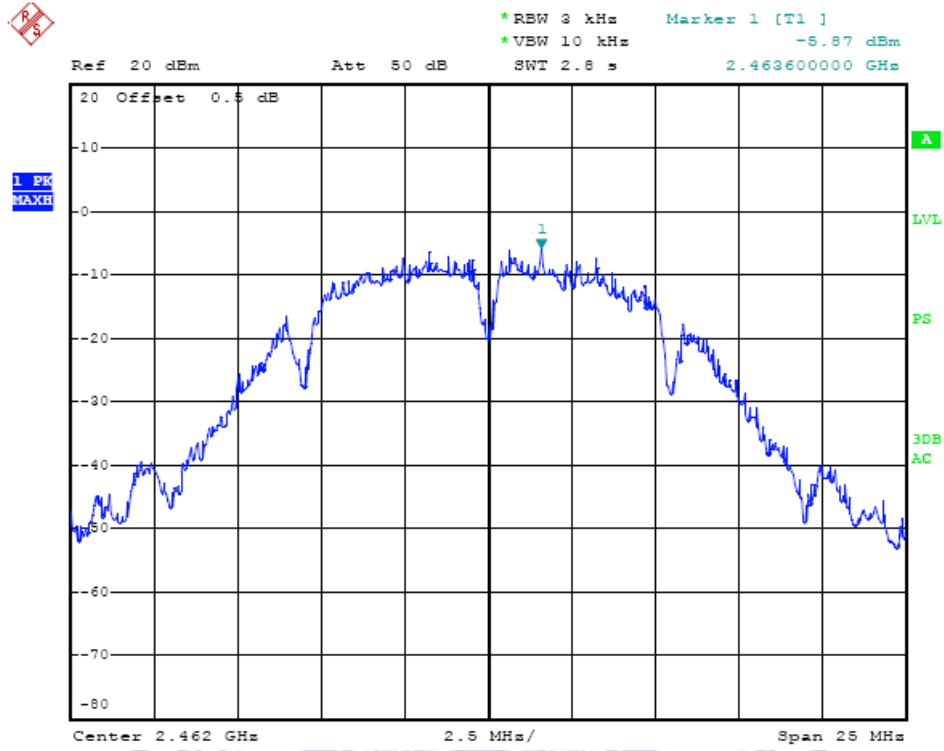

Product	:	Enjoy TV
Test Item	:	Power Spectral Density
Test Mode	:	Mode 2: Transmit by 802.11g

Channel No.	Frequency (MHz)	Measurement PSD (dBm/3KHz)	Limit (dBm/3KHz)	Result
01	2412	-13.79	8	Pass
06	2437	-13.03	8	Pass
11	2462	-13.76	8	Pass

Channel 01 (2412MHz)

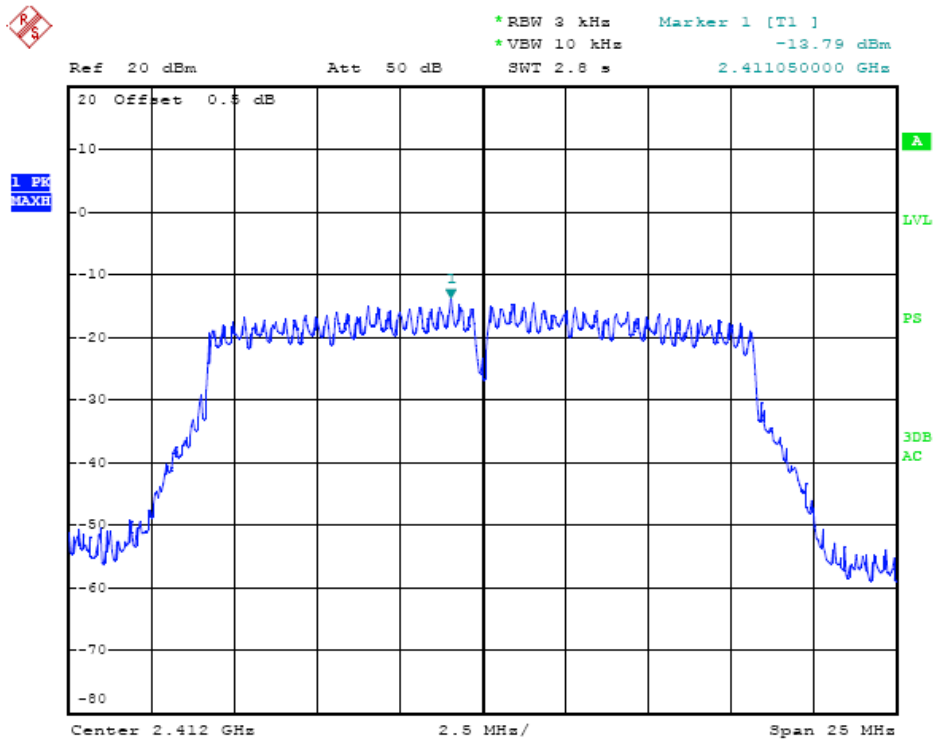

Channel 06 (2437MHz)

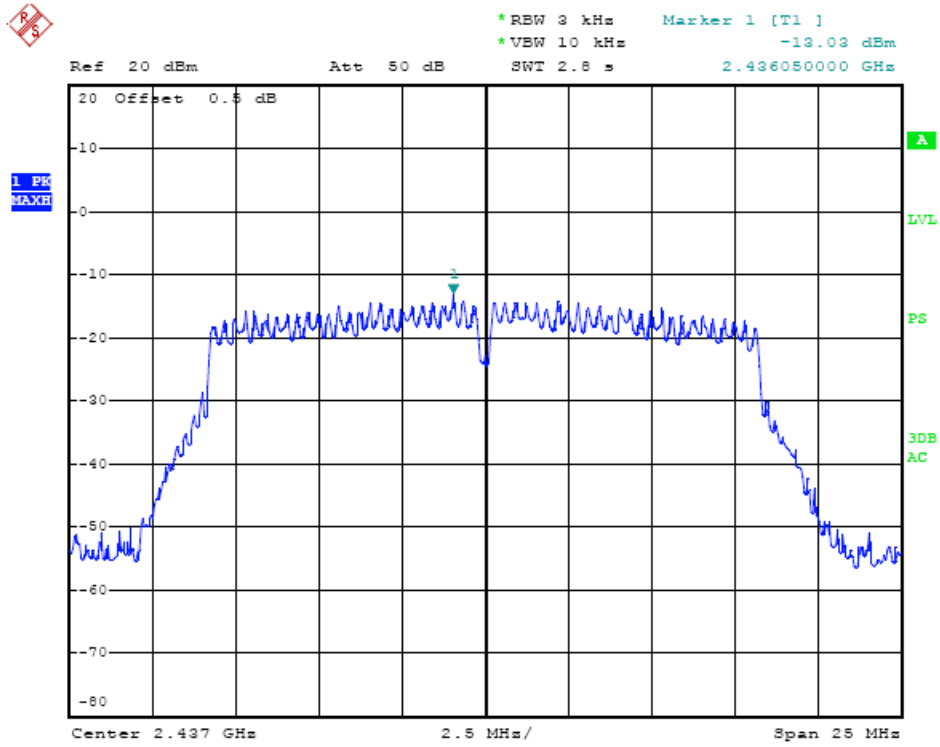

Channel 11 (2462MHz)

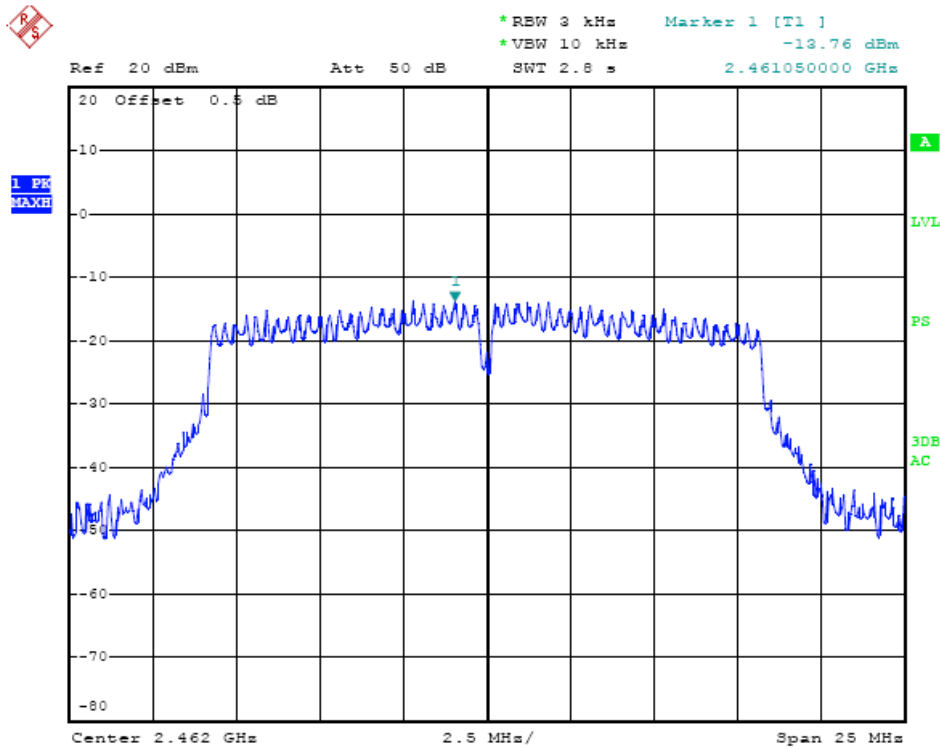

Product	:	Enjoy TV
Test Item	:	Power Spectral Density
Test Mode	:	Mode 3: Transmit by 802.11n (20MHz)

Channel No.	Frequency (MHz)	Measurement PPSD (dBm/3KHz)	Limit (dBm/3KHz)	Result
01	2412	-13.28	8	Pass
06	2437	-13.40	8	Pass
11	2462	-12.89	8	Pass

Channel 01 (2412MHz)

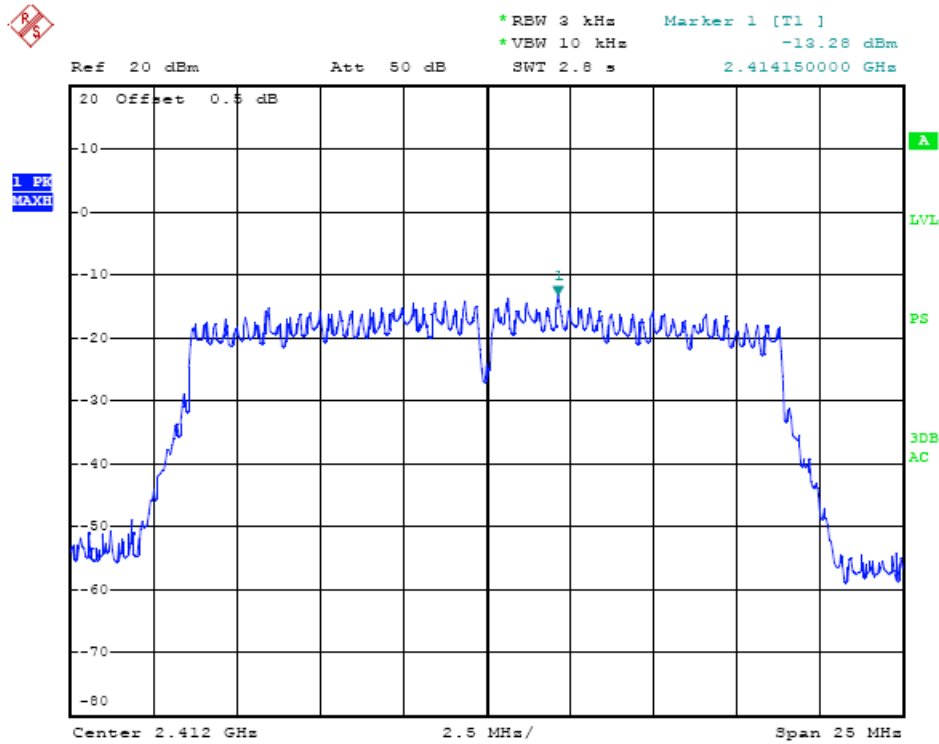

Channel 06 (2437MHz)



*RBW 3 kHz Marker 1 [T1]
*VBW 10 kHz -13.40 dBm
SWT 2.8 s 2.437650000 GHz

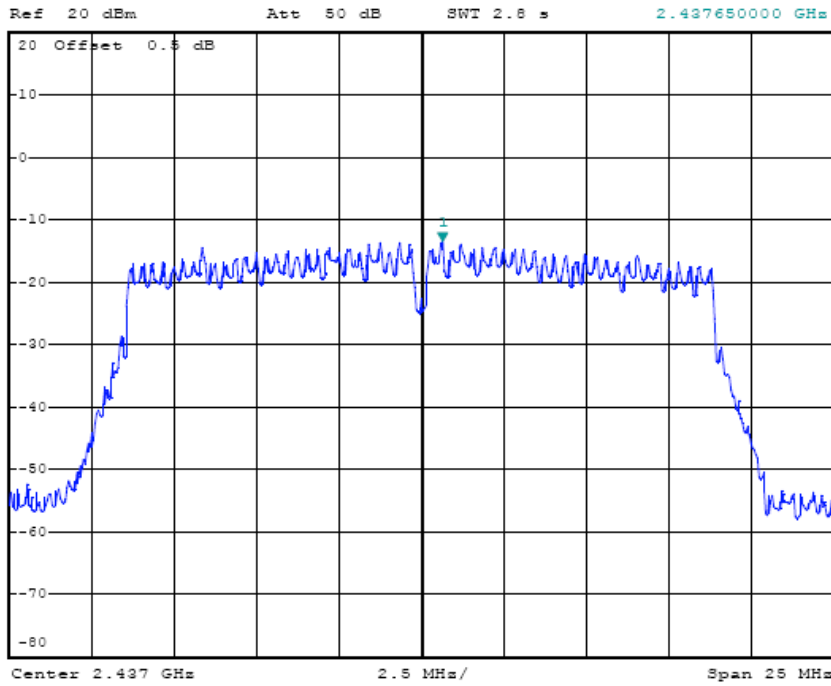

Channel 11 (2462MHz)



*RBW 3 kHz Marker 1 [T1]
*VBW 10 kHz -12.89 dBm
SWT 2.8 s 2.461350000 GHz

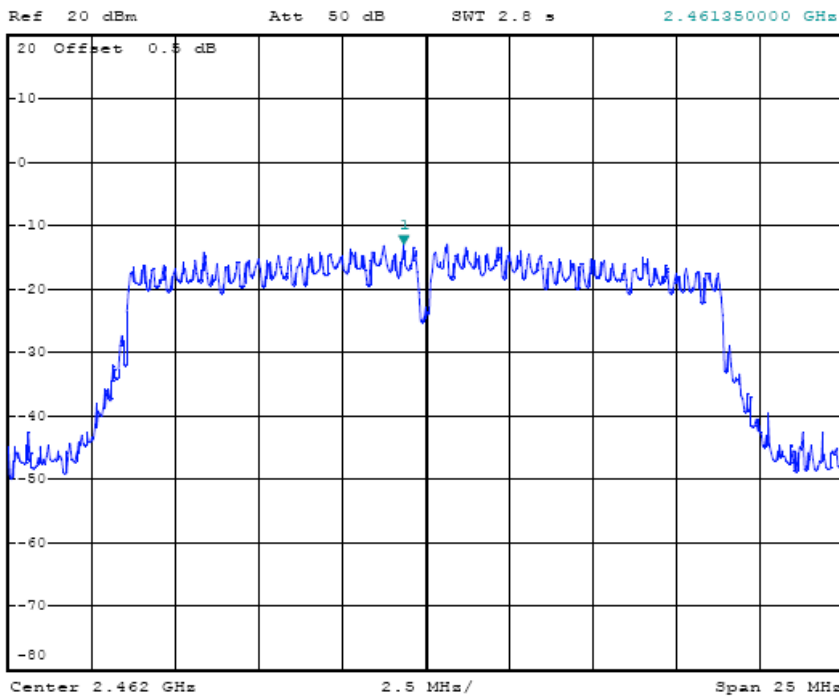

4.7. Spurious RF Conducted Emission

TEST CONFIGURATION

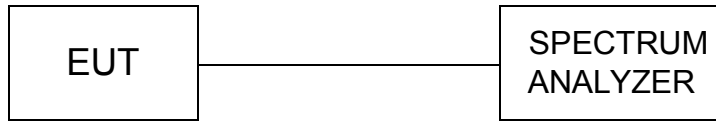

TEST PROCEDURE

The EUT was tested according to KDB558074 D01 v03r02 for compliance to FCC 47CFR 15.247 requirements.

The Spurious RF conducted emissions compliance of RF radiated emission should be measured by following the guidance in ANSI C63.10-2009 with respect to maximizing the emission by rotating the EUT, measuring the emission while the EUT is situated in three orthogonal planes (if appropriate), adjusting the measurement antenna height and polarization etc. Set RBW=100kHz and VBM= 300KHz to measure the peak field strength , and measure frequency range from 30MHz to 26.5GHz.

LIMIT

In any 100 kHz bandwidth outside the frequency band in which the spread spectrum or digitally modulated intentional radiator is operating, the radio frequency power that is produced by the intentional radiator shall be at least 20 dB below that in the 100 kHz bandwidth within the band that contains the highest level of the desired power, based on either an RF conducted or a radiated measurement, provided the transmitter demonstrates compliance with the peak conducted power limits.

TEST RESULTS

Product	:	Enjoy TV
Test Item	:	RF Antenna Conducted Spurious
Test Mode	:	Mode 1: Transmit by 802.11b

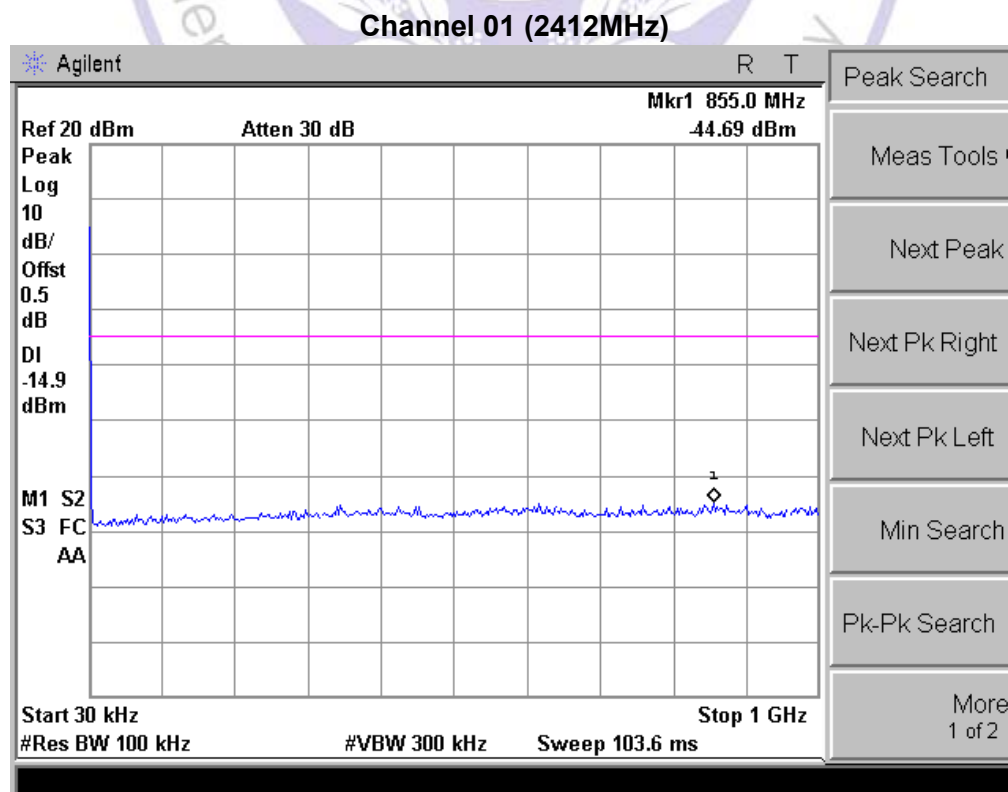

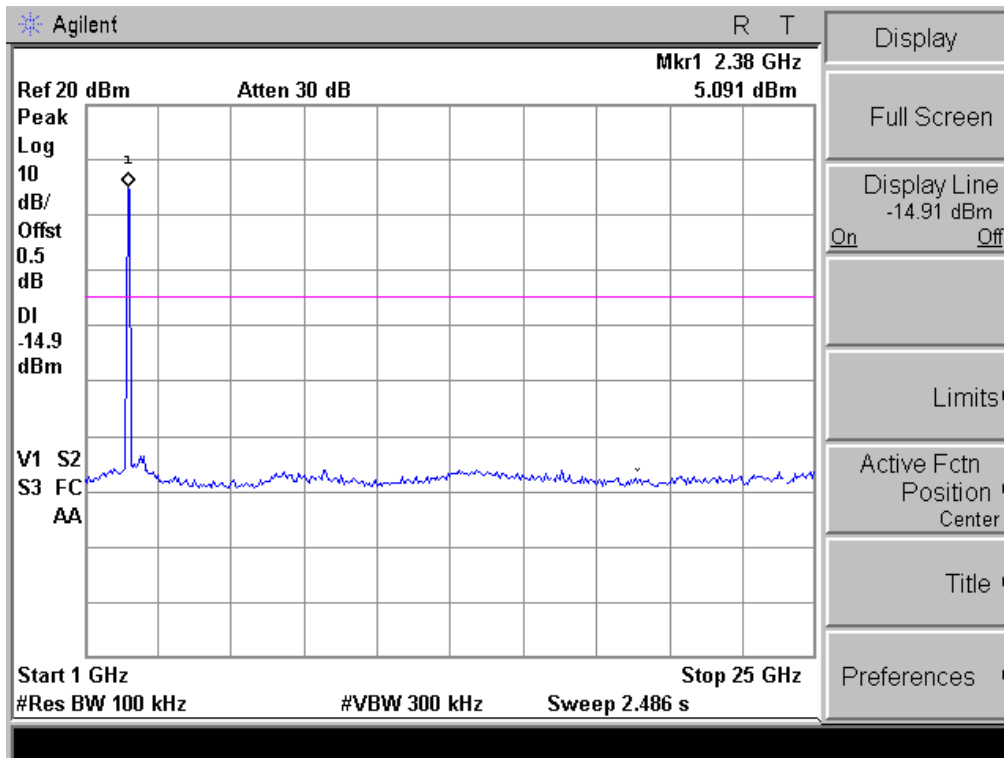

Channel 06 (2437MHz)

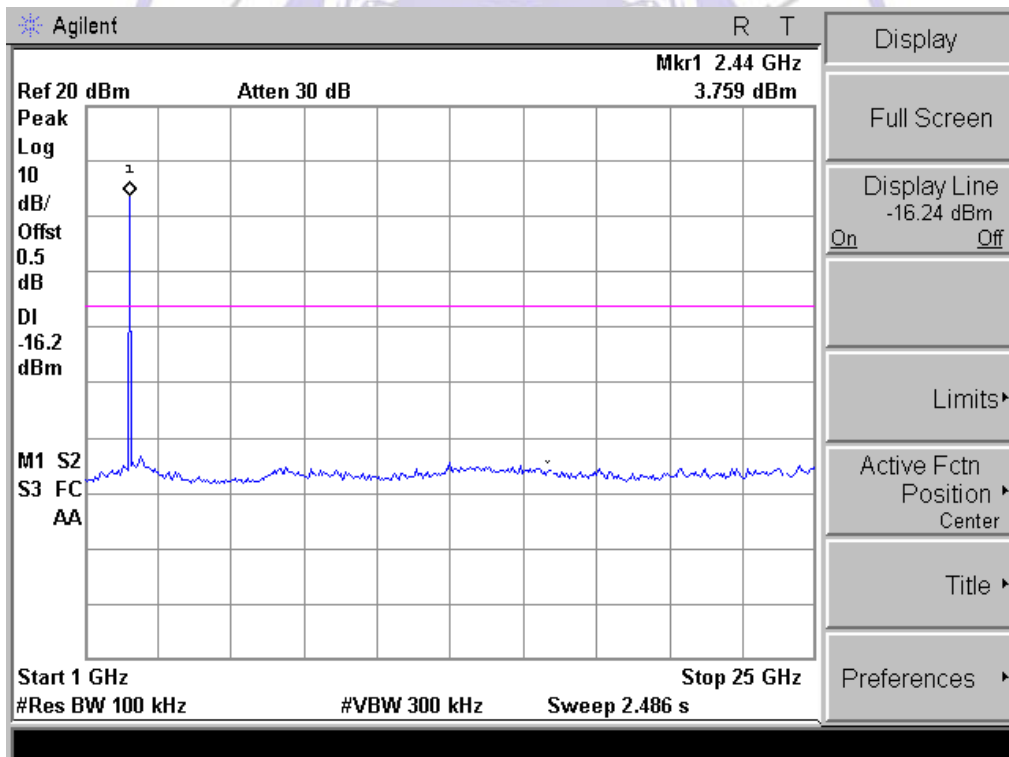
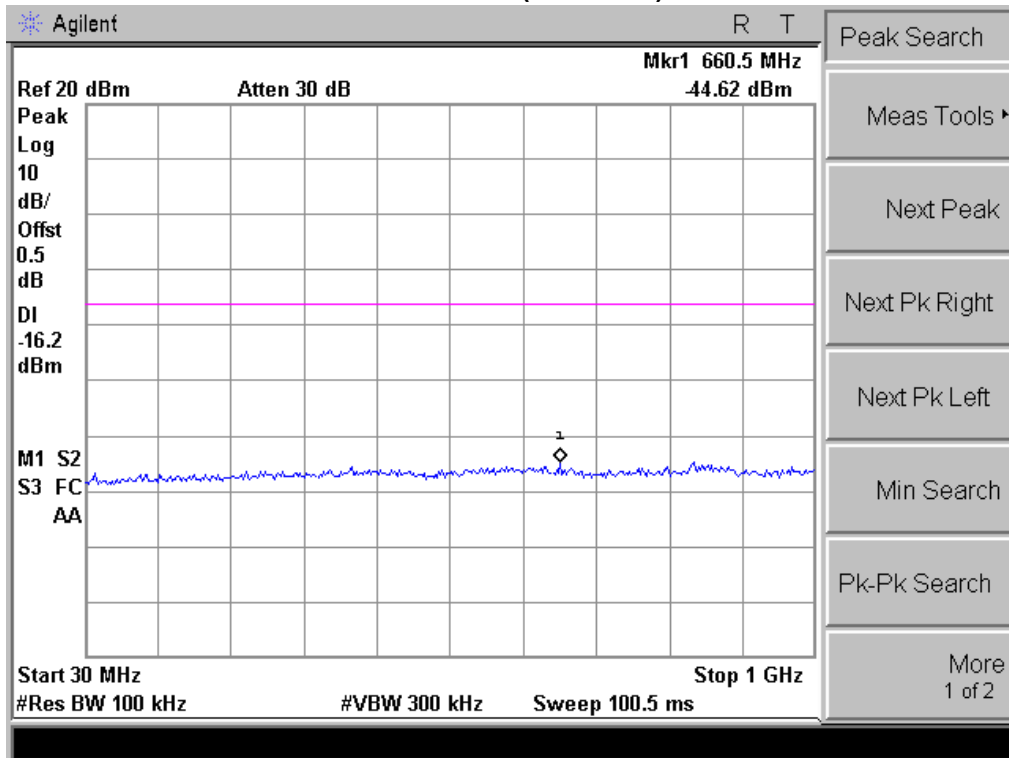

Channel 11 (2462MHz)

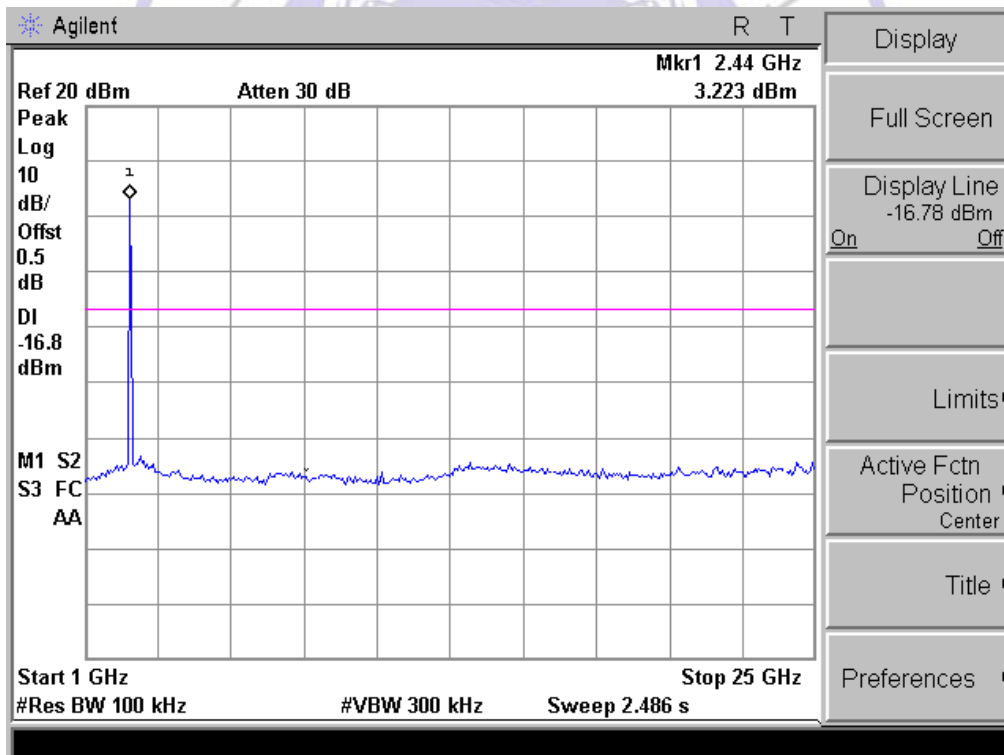
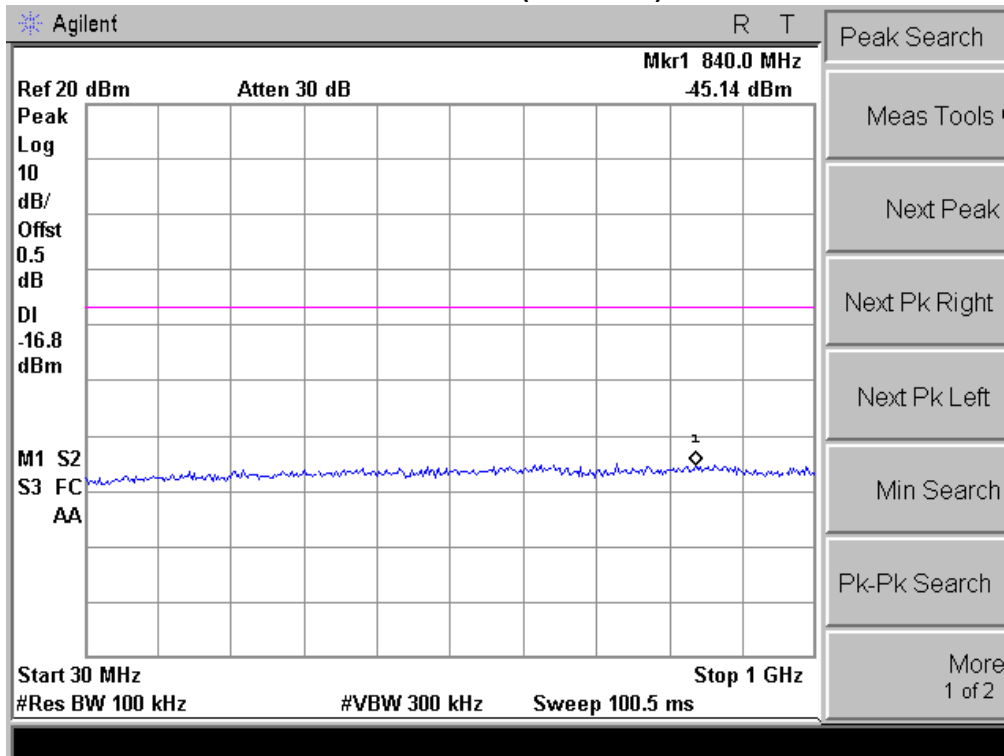

Product	:	Enjoy TV
Test Item	:	RF Antenna Conducted Spurious
Test Mode	:	Mode 2: Transmit by 802.11g

Channel 01 (2412MHz)

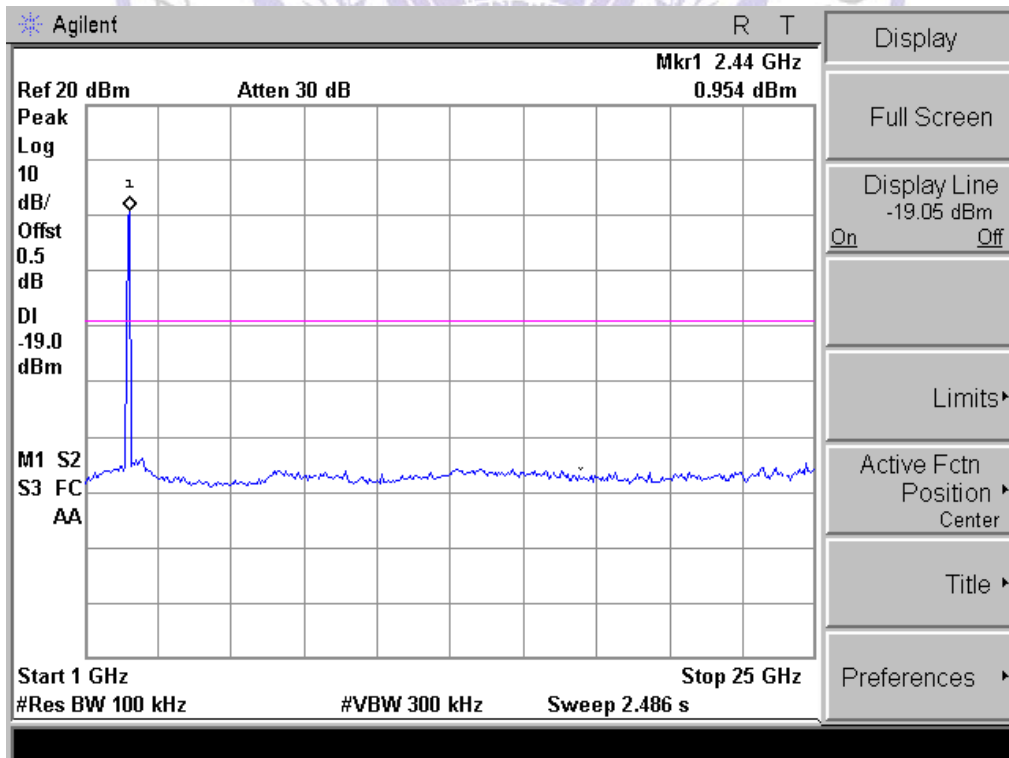
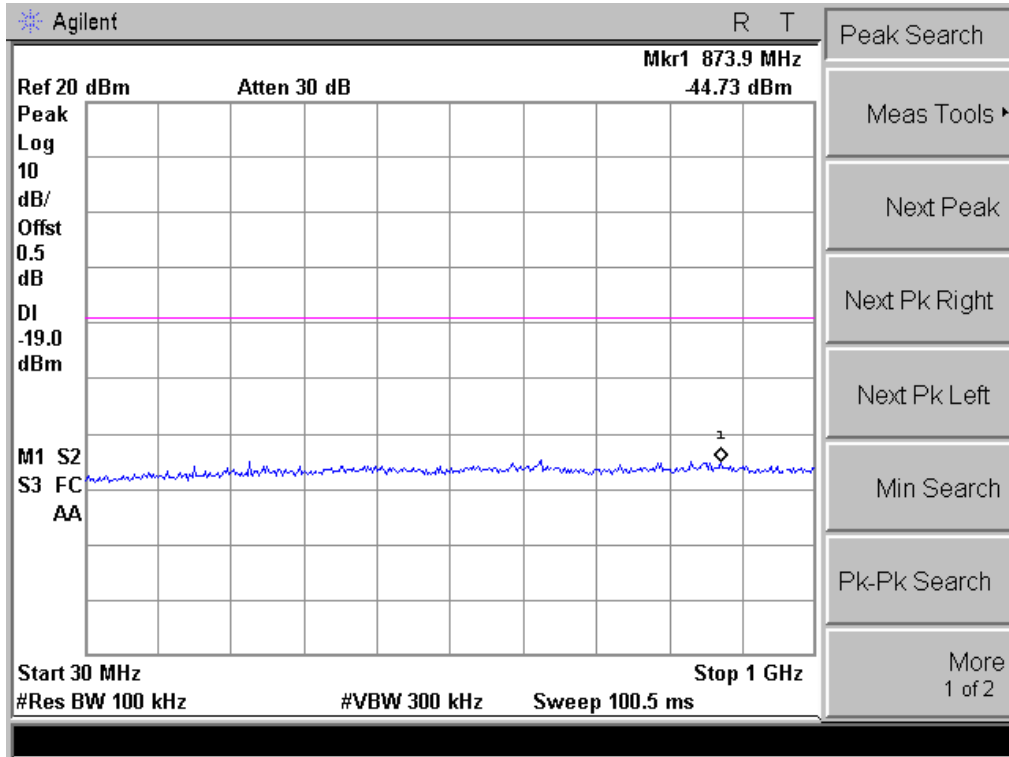

Channel 06 (2437MHz)

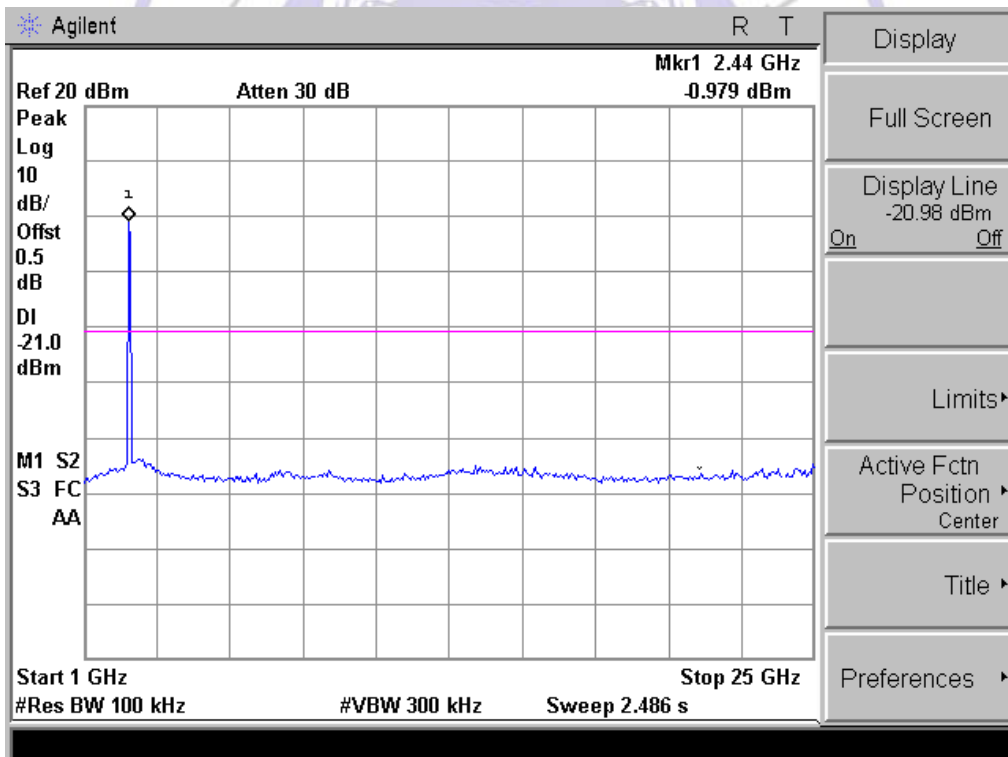
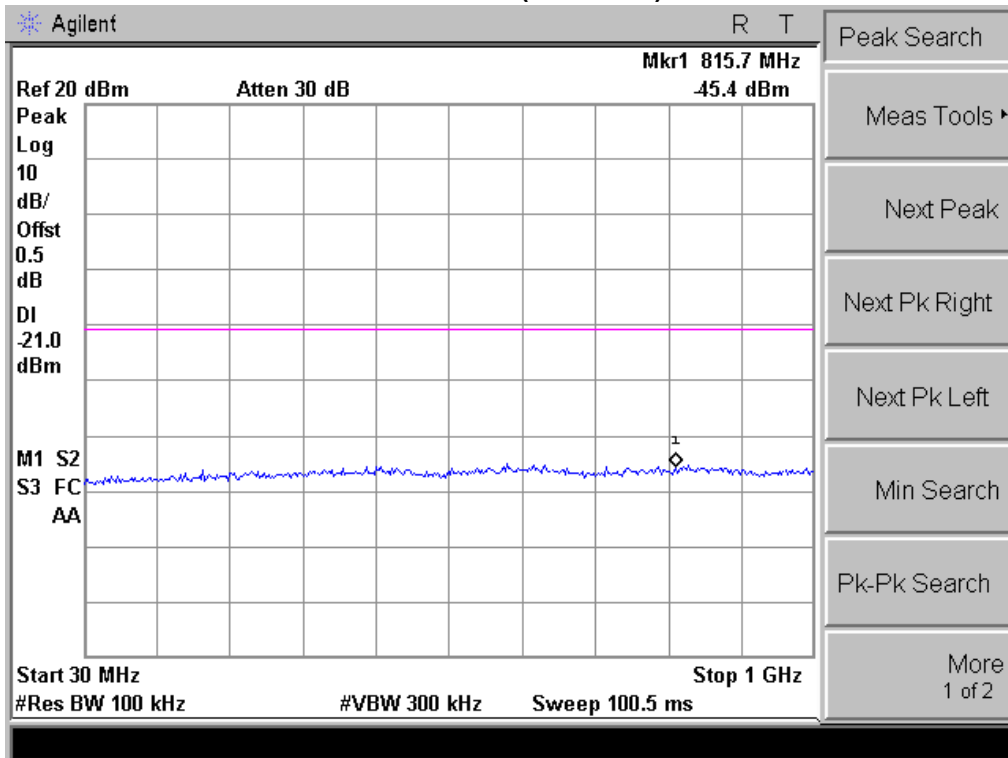

Channel 11 (2462MHz)

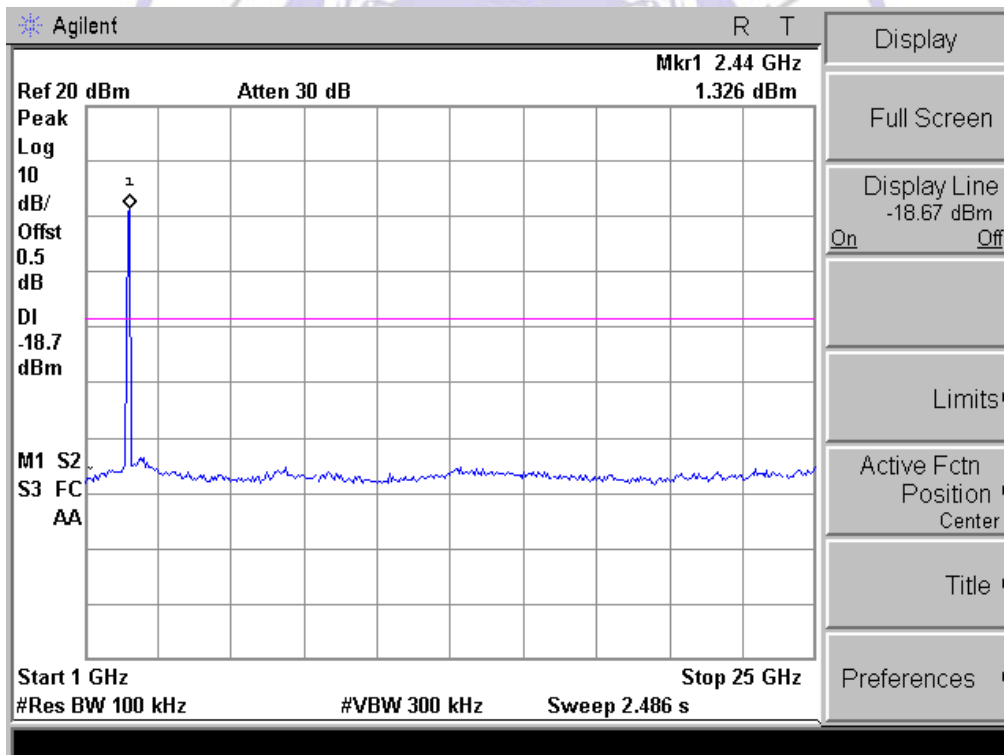
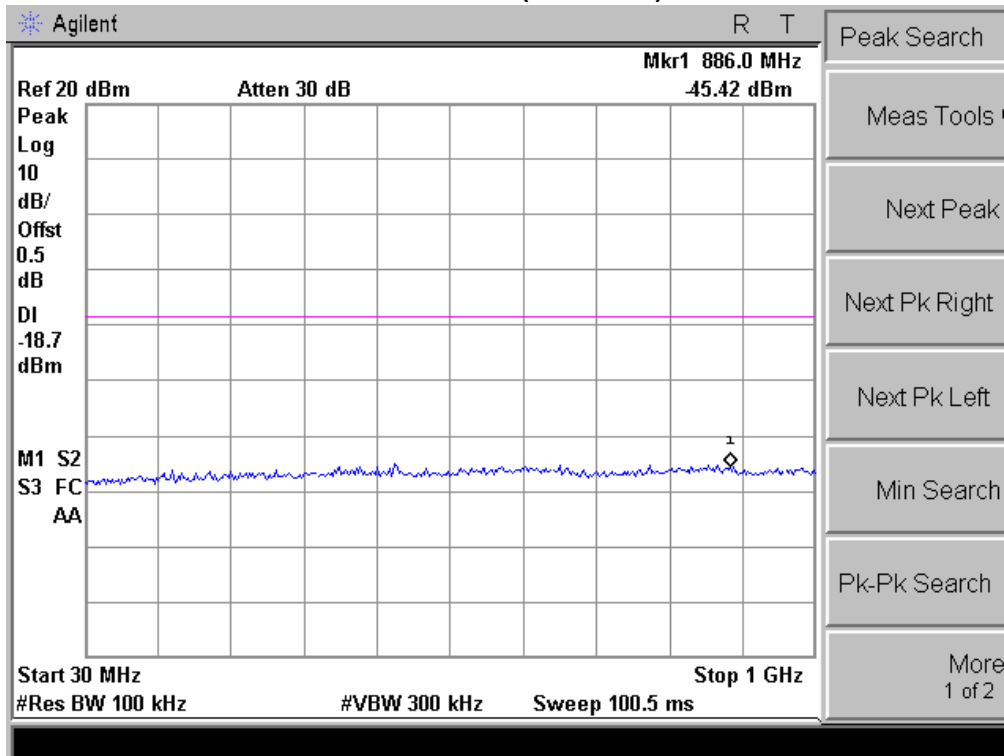

Product	:	Enjoy TV
Test Item	:	RF Antenna Conducted Spurious
Test Mode	:	Mode 3: Transmit by 802.11n (20MHz)

Channel 01 (2412MHz)

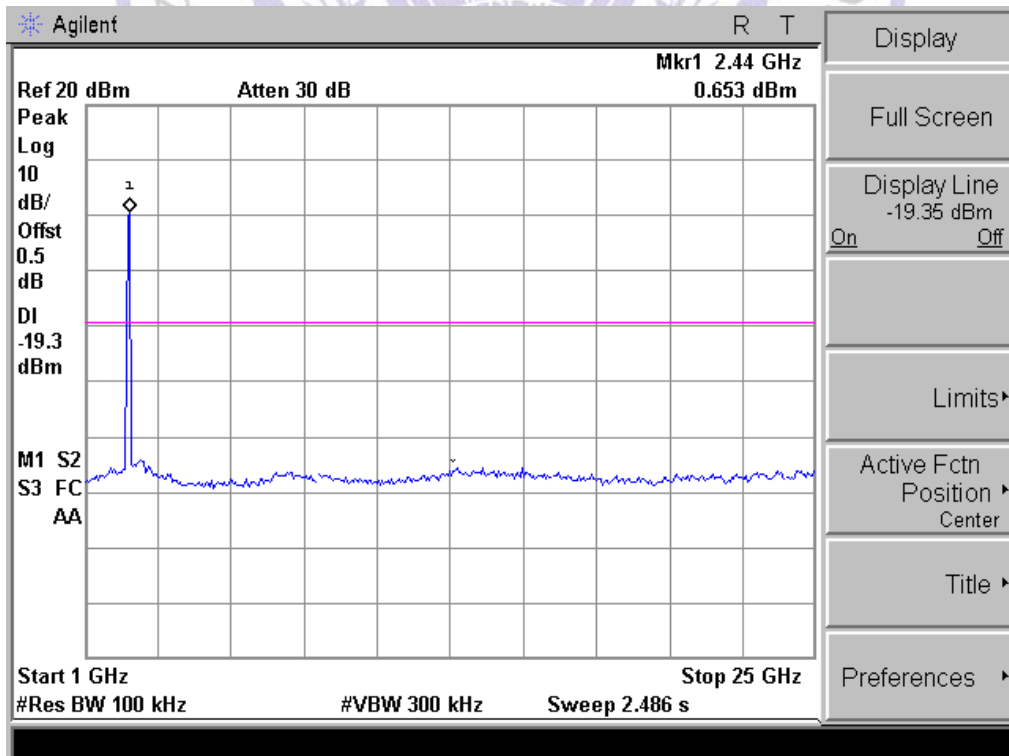
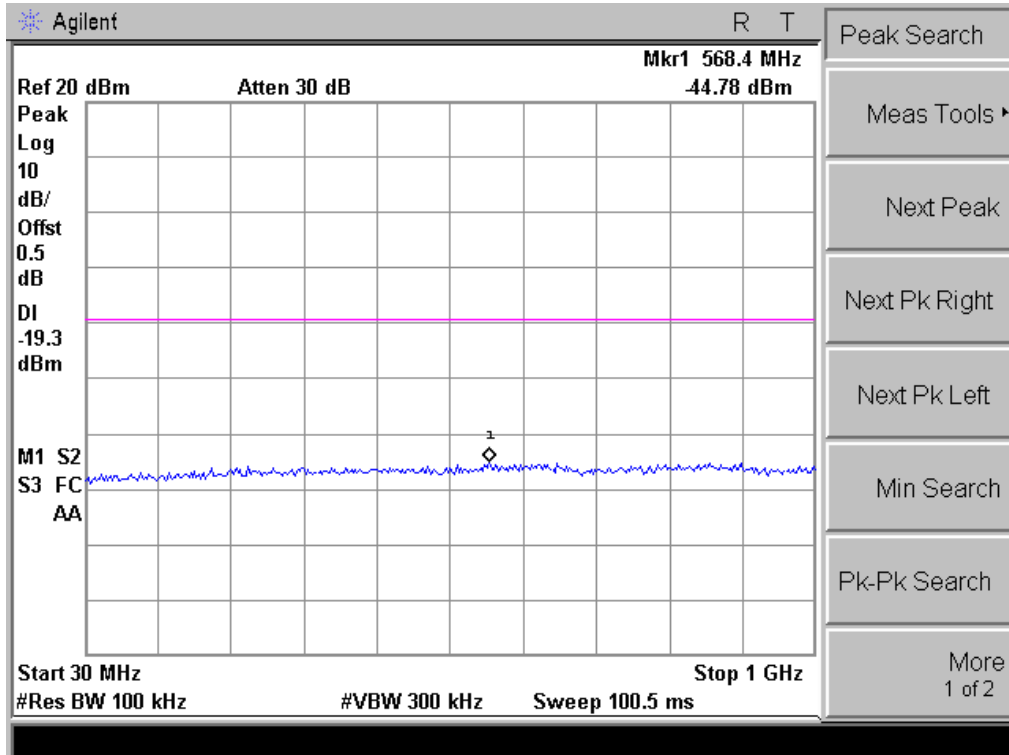

Channel 06 (2437MHz)

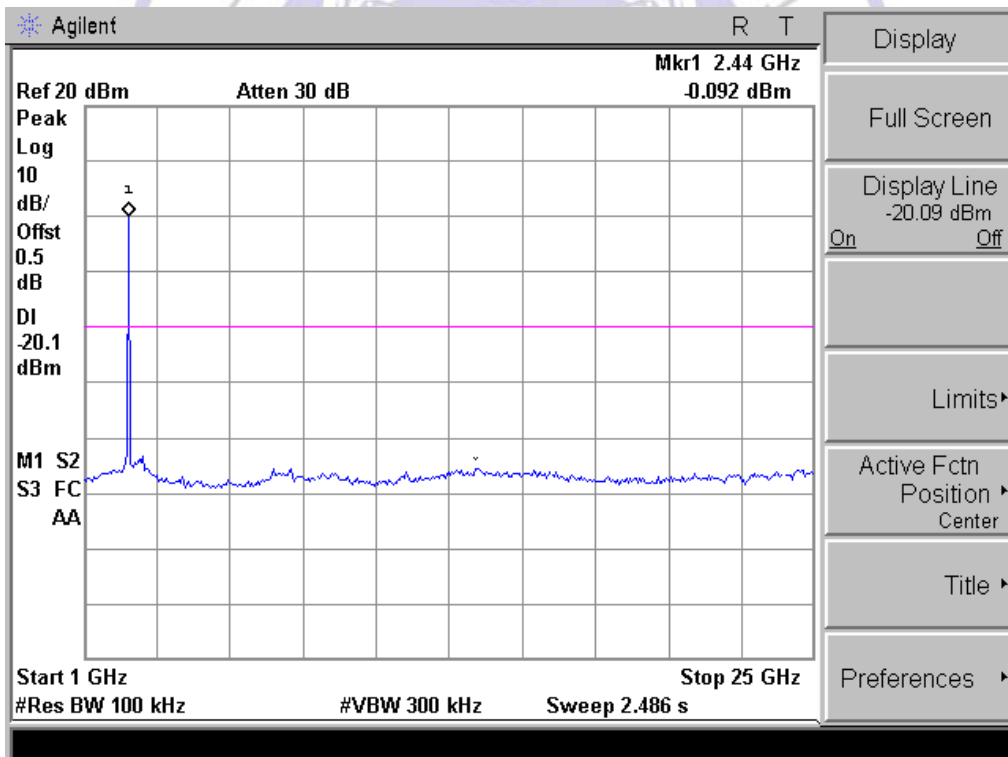
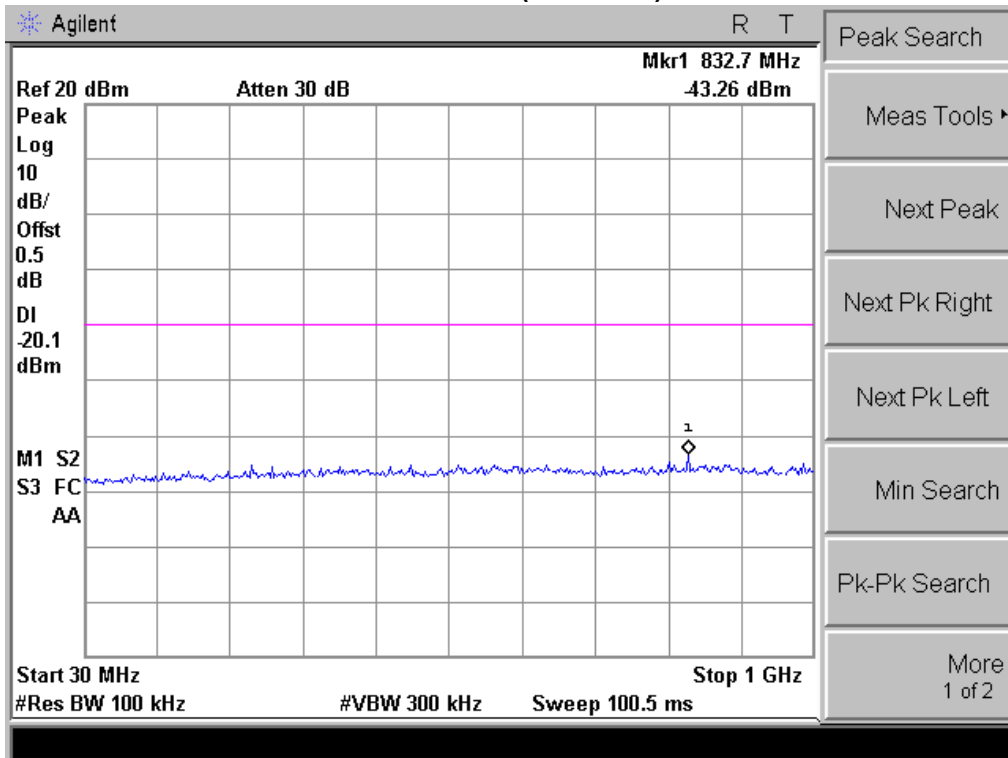

Channel 11 (2462MHz)

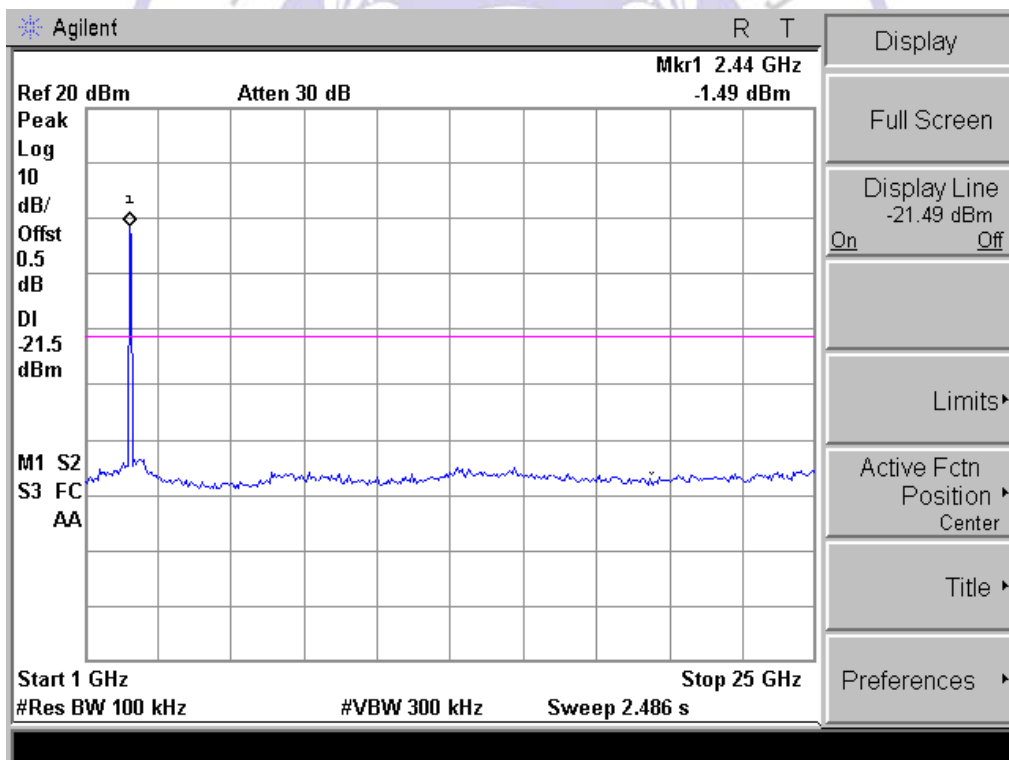
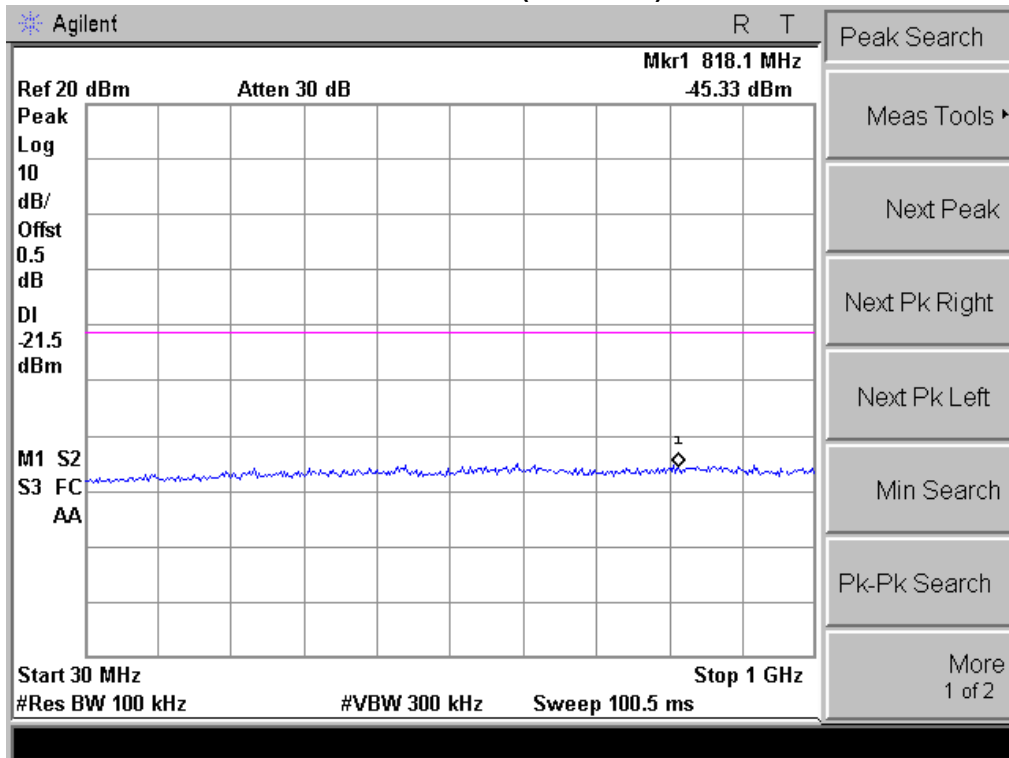

4.8. Antenna Requirement

STANDARD APPLICABLE

For intentional device, according to FCC 47 CFR Section 15.203, an intentional radiator shall be designed to ensure that no antenna other than that furnished by the responsible party shall be used with the device.

And according to FCC 47 CFR Section 15.247 (c), if transmitting antennas of directional gain greater than 6dBi are used, the power shall be reduced by the amount in dB that the directional gain of the antenna exceeds 6dBi.

Refer to statement below for compliance.

The manufacturer may design the unit so that the user can replace a broken antenna, but the use of a standard antenna jack or electrical connector is prohibited. Further, this requirement does not apply to intentional radiators that must be professionally installed.

ANTENNA CONNECTED CONSTRUCTION

The directional gains of antenna used for transmitting is 0.5 dBi, and the antenna connector is a non-standard and inverse spiral interface. Please see photo for details.

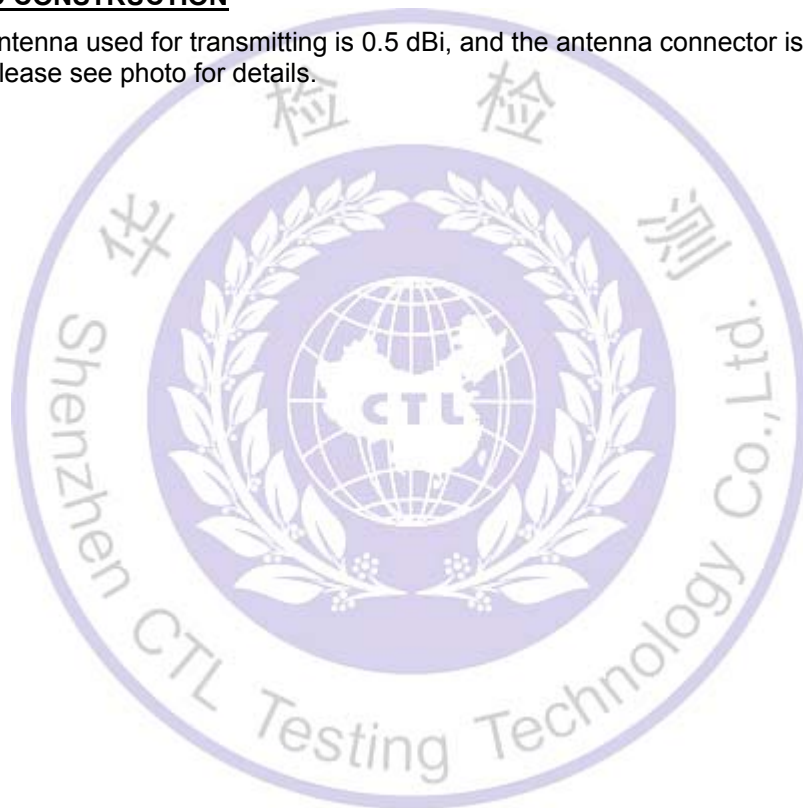

5. Test Setup Photos of the EUT





6. External and Internal Photos of the EUT

External Photos of EUT

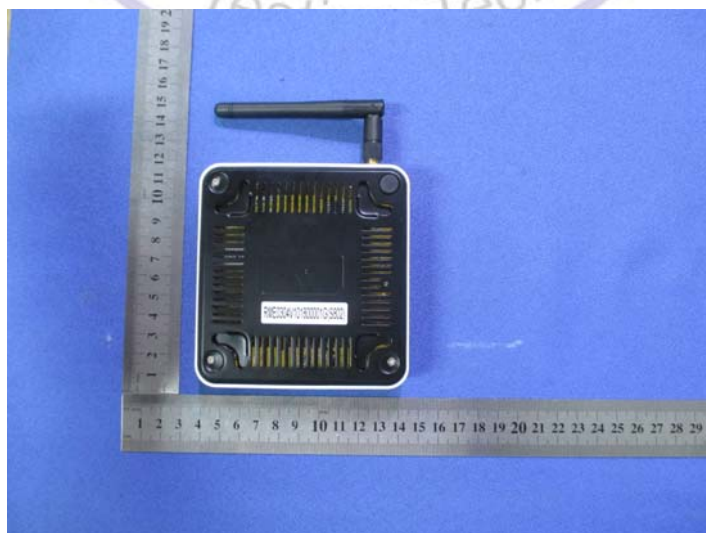
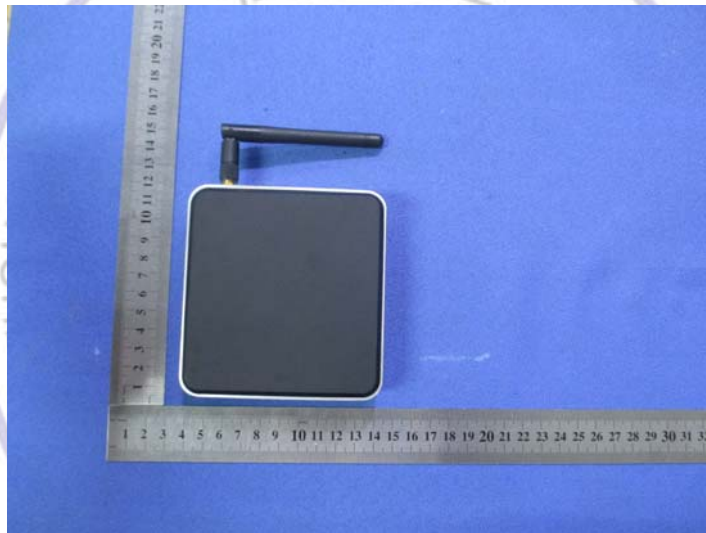





Internal Photos of EUT

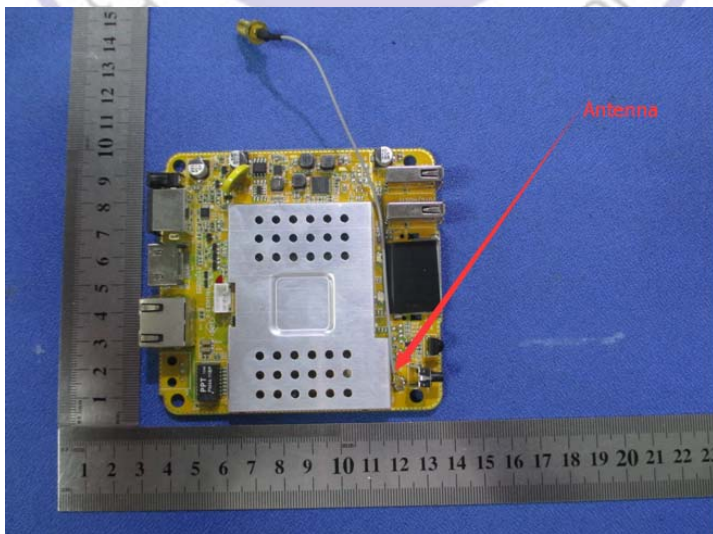
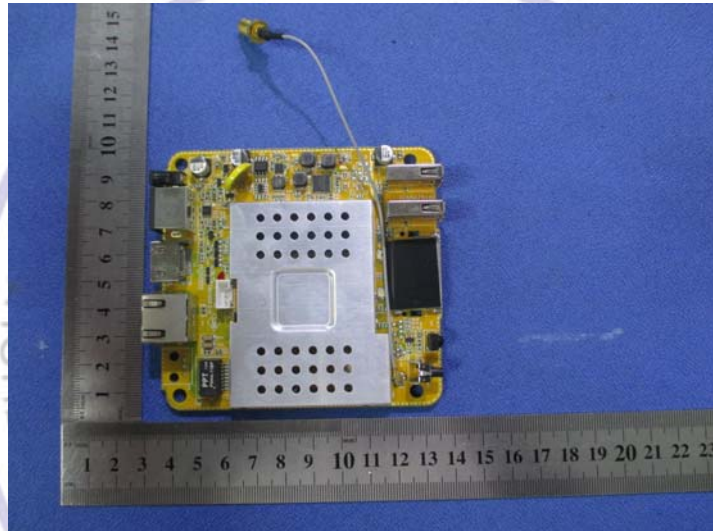
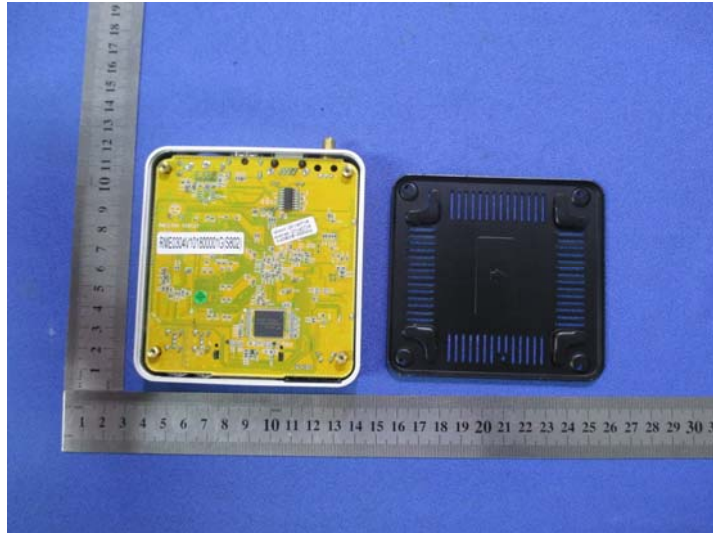

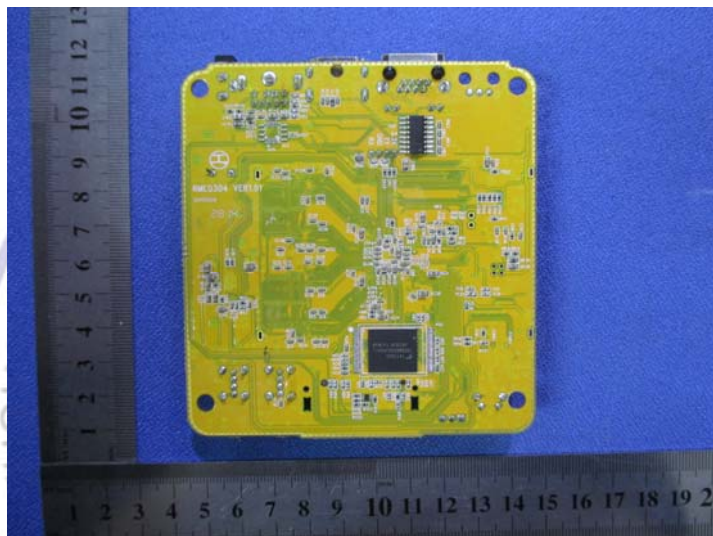



.....End of Report.....