

FCC ID TEST REPORT

for

Android TV BOX

Trade Mark: N/A

Model: ATV500, ATV300, ATV3000, ATV4000, ATV310, ATV1100, ATV510

Test Report Number: TMC20111201EC10

Issued Date: December 20, 2011

Issued for

Shenzhen Geniatech INC.,LTD

**18th F, GDC Building, No. 9 Gaoxin Middle 3rd Rd. Nanshan District,
Shenzhen, China**

Issued by:

TMC Rheinland Testing Services Co., Ltd.

**3F,Building 2,No.335 West of Zhuguang Road,Taoyuan Street,Nanshan
District,Shenzhen,Guangdong,China**

TEL: +86-755-86642861

FAX: +86-755-86642853

***Note:** This report shall not be reproduced except in full, without the written approval of TMC Rheinland Testing Services Co., Ltd. This document may be altered or revised by TMC Rheinland Testing Services Co., Ltd. personnel only, and shall be noted in the revision section of the document. The test results in the report only apply to the tested sample.*

Revision History of report

Rev.	Issue No.	Revisions	Effect Page	Revised By
00	TMC20111201EC10	Initial Issue	ALL	Kallen Wang

TABLE OF CONTENTS

1	TEST RESULT CERTIFICATION.....	4
2	TEST RESULT SUMMARY	5
3	EUT DESCRIPTION.....	6
4	TEST METHODOLOGY.....	7
4.1	DECISION OF FINAL MODE.....	7
4.2	EUT SYSTEM OPERATION.....	7
5	SETUP OF EQUIPMENT UNDER TEST.....	8
5.1	DESCRIPTION OF SUPPORT UNITS.....	8
5.2	CONFIGURATION OF SYSTEM UNDER TEST.....	8
6	FACILITIES AND MEASUREMENT UNCERTAINTY.....	9
6.1	FACILITIES.....	9
6.2	MEASUREMENT UNCERTAINTY.....	9
7	CONDUCTED EMISSION MEASUREMENT	10
7.4	TEST SETUP.....	11
7.5	TEST RESULTS.....	11
8	RADIATED EMISSION MEASUREMENT.....	14
8.1	LIMITS OF RADIATED EMISSION MEASUREMENT.....	14
8.2	TEST INSTRUMENTS.....	14
8.3	TEST PROCEDURES.....	15
8.4	TEST SETUP.....	16
8.5	TEST RESULTS.....	17

1 TEST RESULT CERTIFICATION

Product:	Android TV BOX
Model:	ATV500, ATV300, ATV3000, ATV4000, ATV310, ATV1100, ATV510
Trade Mark:	N/A
Applicant:	Shenzhen Geniatech INC.,LTD 18th F, GDC Building, No. 9 Gaoxin Middle 3rd Rd. Nanshan District, Shenzhen, China
Factory	Shenzhen Geniatech INC.,LTD 18th F, GDC Building, No. 9 Gaoxin Middle 3rd Rd. Nanshan District, Shenzhen, China
Tested Date:	December 10, 2011 ~ December 20, 2011
Test Voltage:	DC 5V By Adapter

APPLICABLE STANDARDS	
STANDARD	TEST RESULT
FCC PART 15B	No non-compliance noted
ANSI C63.4: 2003	No non-compliance noted

Note: 1. The test result judgment is decided by the limit of measurement standard
 2. The information of measurement uncertainty is available upon the customer's request.

The above equipment has been tested by TMC Rheinland Testing Services Co., Ltd. and found compliance with the requirements set forth in the technical standards mentioned above. The results of testing in this report apply only to the product/system, which was tested. Other similar equipment will not necessarily produce the same results due to production tolerance and measurement uncertainties.

Tested By: *Davis ma*
 (Davis Ma)

Date: December 20, 2011

Check By: *Merry Zhao*
 (Merry Zhao)

Date: December 20, 2011

Approved By: *Lisa Zhu*
 (Lisa Zhu)

Date: December 20, 2011

2 TEST RESULT SUMMARY

Test Item	Test Result
Conduct Emission	Pass
Radiation Emission	Pass

- Note:** 1. The test result judgment is decided by the limit of test standard
2. The information of measurement uncertainty is available upon the customer's request.
3. N/A means to no applicable.

3 EUT DESCRIPTION

Product	Android TV BOX
Brand Name	N/A
Model	ATV500, ATV300, ATV3000, ATV4000, ATV310, ATV1100, ATV510
Applicant	Shenzhen Geniatech INC.,LTD
Serial Number	N/A
EUT Power Rating	DC 5V
Temperature Range(Operating)	15-35°C
Operating Frequency	N/A

N/A mean to no applicable

Models difference

All models have the same constructions, circuit diagram and PCB layout. Only model name are different.

4 TEST METHODOLOGY

4.1 DECISION OF FINAL TEST MODE

The EUT was tested together with the thereafter additional components, and a configuration, which produced the worst emission levels, was selected and recorded in this report.

The following test mode(s) were scanned during the preliminary test:

Pre-Test Mode		
Emission	Conducted Emission	Mode : Running
	Radiated Emission	Mode : Running

After the preliminary scan, the following test mode was found to produce the highest emission level.

The Worst Test Mode		
Emission	Conducted Emission	Mode : Running
	Radiated Emission	Mode : Running

4.2 EUT SYSTEM OPERATION

1. Set up EUT with the relative support equipments.
2. Make sure the EUT normal operation during the test.

5 SETUP OF EQUIPMENT UNDER TEST

5.1 DESCRIPTION OF SUPPORT UNITS

The EUT has been tested as an independent unit together with other necessary accessories or support units. The following support units or accessories were used to form a representative test configuration during the tests.

No.	Equipment	Model No.	Serial No.	FCC ID	Trade Name	Data Cable	Power Cord
1	U dish	N/A	CNG7140T7P	N/A	HP	Unshielded 1.6m	N/A
2	Monitor	HPL1706V	CND74535YZ	N/A	HP	Unshielded 1.6m	N/A
3	Adapter	SW108SMD	N/A	N/A	N/A	Unshielded 1.6m	N/A

Note:

- 1) All the equipment/cables were placed in the worst-case configuration to maximize the emission during the test.
- 2) Grounding was established in accordance with the manufacturer's requirements and conditions for the intended use.

5.2 CONFIGURATION OF SYSTEM UNDER TEST

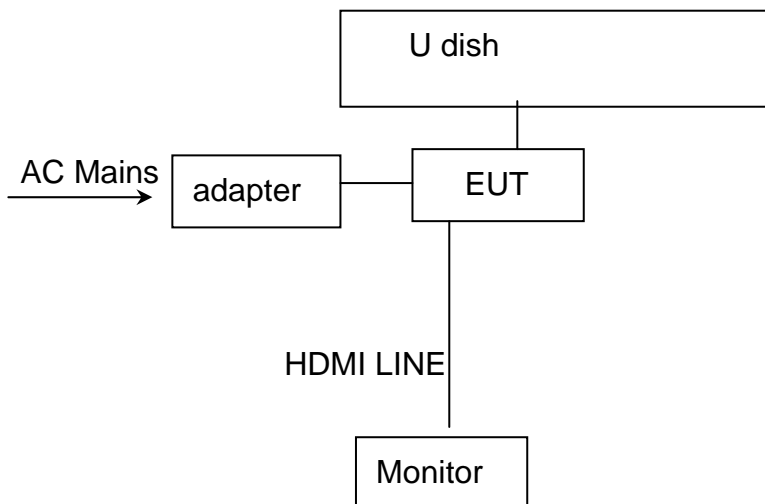

(EUT: Android TV BOX)

6 FACILITIES AND MEASUREMENT UNCERTAINTY

6.1 FACILITIES

The test site used to collect the radiated data is located on the address of emitel (Shenzhen) Limited (FCC Registered Test Site Number: 746887) on Building 2, 171 Meihua Road, Futian District, Shenzhen, 518049 China. The Test Site is constructed and calibrated to meet the FCC requirements.

6.2 MEASUREMENT UNCERTAINTY

Where relevant, the following measurement uncertainty levels have been estimated for tests performed on the EUT as specified in CISPR 16-4-2:

Measurement	Frequency		Uncertainty
Conducted emissions	450kHz~30MHz		+/- 3.59dB
Radiated emissions	Horizontal	30MHz ~ 200MHz	+/- 4.77dB
		200MHz ~1000MHz	+/- 4.93dB
	Vertical	30MHz ~ 200MHz	+/- 5.04dB
		200MHz ~1000MHz	+/- 4.93dB

This uncertainty represents an expanded uncertainty expressed at approximately the 95% confidence level using a coverage factor of k=2.

7 CONDUCTED EMISSION MEASUREMENT

7.1 LIMITS

FREQUENCY (MHz)	LIMIT(dBuV)	
	Quasi-peak	Average
0.15 - 0.5	66 - 56	56 - 46
0.50 - 5.0	56	46
5.0 - 30.0	60	50

NOTE:

- (1) The lower limit shall apply at the transition frequencies.
- (2) The limit decreases in line with the logarithm of the frequency in the range of 0.15 to 0.50 MHz.
- (3) All emanations from EUT or system, shall not exceed the level of field strengths specified above.

7.2 TEST INSTRUMENTS

Conducted Emission Shielding Room Test Site (843)					
Name of Equipment	Manufacturer	Model	Serial Number	calibration date	Calibration Due
EMI Test Receiver	R&S	ESCI	100005	06/24/2011	06/24/2012
LISN	AFJ	LS16	1601022211 9	09/29/2011	09/29/2012
LISN(EUT)	Mestec	AN3016	04/10040	09/28/2011	09/28/2012

- NOTE:** 1. The calibration interval of the above test instruments is 12 months and the calibrations are traceable to international system unit (SI).
 2. N.C.R = No Calibration Request.

7.3 TEST PROCEDURES

The EUT was put on a wooden table which was 0.8metre high above the ground and connected to the AC mains through a Artificial Mains Network (A.M.N). The mains lead in excess of 1 m separating the EUT from the AMN was folded back and forth parallel to the lead so as to form a bundle with a length of 0.3m to 0.4m. The EUT was kept 0.4m from any other earthed conducting surface. Both sides of AC line were checked to find out the maximum conducted emission levels according to the test procedure during conducted emission test.

The bandwidth of the test receiver (ESCI) was set at 9KHz.

The frequency range from 150 KHz to 30 MHz was investigated.

The test data of the worst-case condition(s) was recorded.

7.4 TEST SETUP

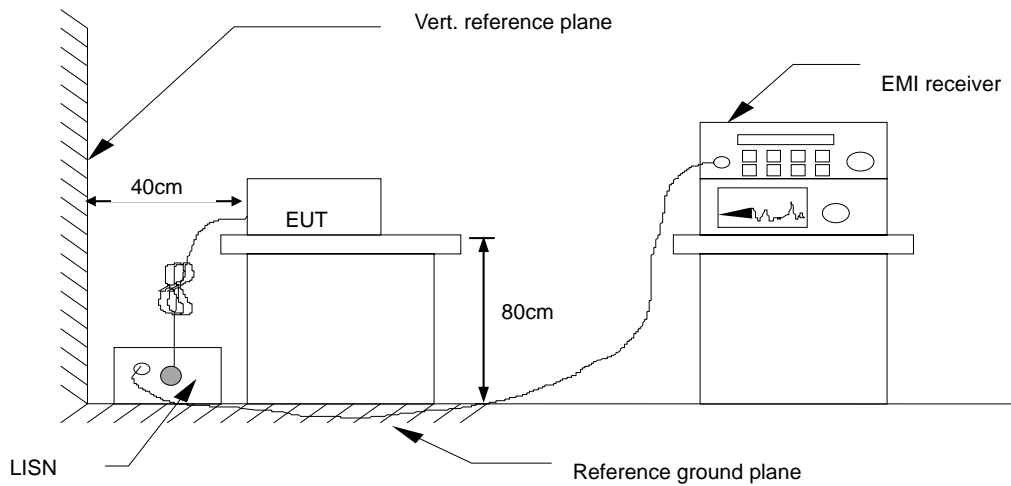

For the actual test configuration, please refer to the related item – Photographs of the Test Configuration.

7.5. TEST RESULTS

Please refer to following diagram for individual

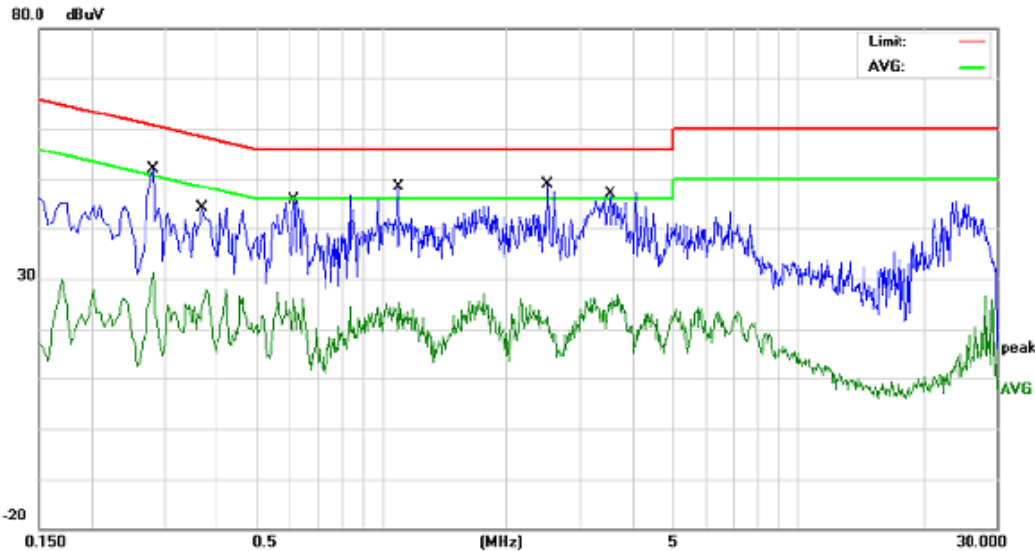
Conducted Emission Measurement

Site 843 Shielded Room

 Phase: **L1**

Temperature: 26

Power: AC 230V/50Hz

Humidity: 55 %

No.	Mk.	Freq. MHz	Reading Level dBuV	Correct Factor dB	Measure- ment dBuV	Limit dBuV	Over dB	Detector	Comment
1		0.2819	39.32	10.84	50.16	60.76	-10.60	QP	
2		0.2819	17.72	10.84	28.56	50.76	-22.20	AVG	
3		0.3700	31.26	10.75	42.01	58.50	-16.49	QP	
4		0.3700	14.69	10.75	25.44	48.50	-23.06	AVG	
5		0.6140	32.98	10.48	43.46	56.00	-12.54	QP	
6		0.6140	10.97	10.48	21.45	46.00	-24.55	AVG	
7		1.0980	32.35	10.25	42.60	56.00	-13.40	QP	
8		1.0980	10.71	10.25	20.96	46.00	-25.04	AVG	
9	*	2.5059	37.52	10.32	47.84	56.00	-8.16	QP	
10		2.5059	9.14	10.32	19.46	46.00	-26.54	AVG	
11		3.5420	34.67	10.36	45.03	56.00	-10.97	QP	
12		3.5420	10.61	10.36	20.97	46.00	-25.03	AVG	

*:Maximum data x:Over limit l:over margin

(Reference Only)

Conducted Emission Measurement

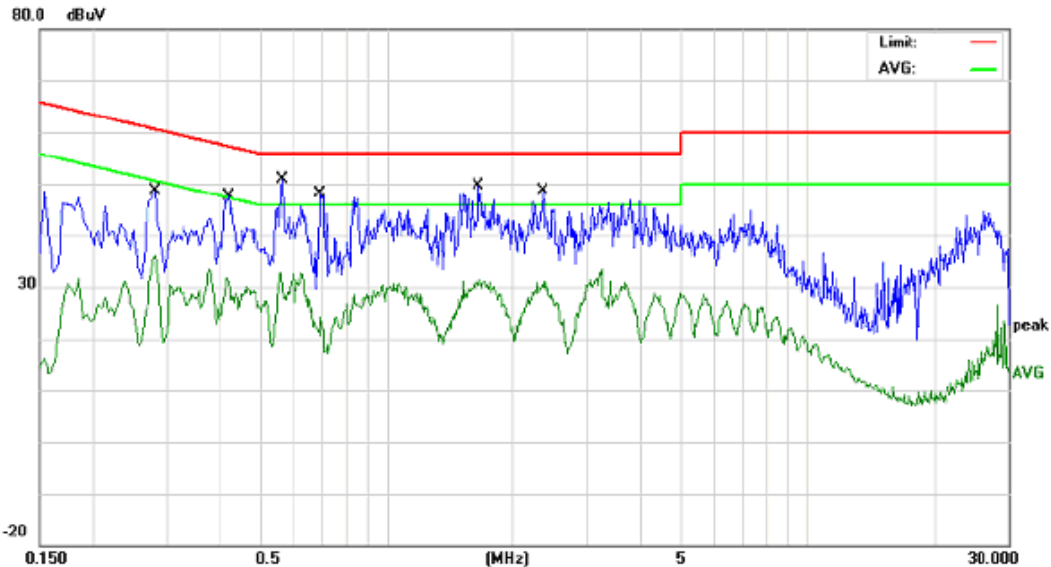

Site 843 Shielded Room

Phase: **N**

Temperature: 26

Power: AC 230V/50Hz

Humidity: 55 %

No.	Mk.	Freq. MHz	Reading Level dBuV	Correct Factor dB	Measure- ment dBuV	Limit dBuV	Over dB	Detector	Comment
1		0.2819	35.25	10.84	46.09	60.76	-14.67	QP	
2		0.2819	22.46	10.84	33.30	50.76	-17.46	AVG	
3		0.4220	33.94	10.87	44.61	57.41	-12.80	QP	
4		0.4220	20.03	10.87	30.70	47.41	-16.71	AVG	
5	*	0.5660	38.69	10.51	49.20	56.00	-6.80	QP	
6		0.5660	18.61	10.51	29.12	46.00	-16.88	AVG	
7		0.6940	35.29	10.43	45.72	56.00	-10.28	QP	
8		0.6940	12.00	10.43	22.43	46.00	-23.57	AVG	
9		1.6620	37.53	10.27	47.80	56.00	-8.20	QP	
10		1.6620	19.98	10.27	30.25	46.00	-15.75	AVG	
11		2.3460	34.97	10.30	45.27	56.00	-10.73	QP	
12		2.3460	19.19	10.30	29.49	46.00	-16.51	AVG	

*:Maximum data x:Over limit !:over margin

<Reference Only

8 RADIATED EMISSION MEASUREMENT

8.1. LIMITS OF RADIATED EMISSION MEASUREMENT

Maximum permissible level of Radiated Emission measured at 3 meter

FREQUENCY (MHz)	dBuV/m (At 3m)
	Class B
30~88	40.00
88~216	43.50
216~960	46.00
960~1000	54.00
>1000	PK:74;AV:54

NOTE: (1) The lower limit shall apply at the transition frequencies.

(2) Emission level (dBuV/m) = 20 log Emission level (uV/m).

(3) The limit below 1GHz use QP detector

8.2. TEST INSTRUMENTS

966 Chamber					
Name of Equipment	Manufacturer	Model	Serial Number	calibration date	Calibration Due
EMI Test Receiver	ROHDE&SCHWARZ	ESCI	100005	09/24/2011	09/24/2012
Spectrum Analyzer	R&S	FSU	100114	09/24/2011	09/24/2012
Pre Amplifier	H.P.	HP8447E	2945A02715	09/24/2011	09/24/2012
Pre-Amplifier	Compliance	PAM0118	1360976	09/24/2011	09/24/2012
Bilog Antenna	SUNOL Sciences	JB3	A021907	09/24/2011	09/24/2012
Horn Antenna	Compliance	CE18000	001	09/24/2011	09/24/2012
Cable	TIME MICROWAVE	LMR-400	N-TYPE04	09/24/2011	09/24/2012
Cable	TIME MICROWAVE	--	--	09/24/2011	09/24/2012
Signal generator	HP	8657B	101059-999	09/24/2011	09/24/2012
System-Controller	CCS	N/A	N/A	N.C.R	N.C.R
Turn Table	CCS	N/A	N/A	N.C.R	N.C.R
Antenna Tower	CCS	N/A	N/A	N.C.R	N.C.R

NOTE: 1. The calibration interval of the above test instruments is 12 months and the calibrations are traceable to International system of unit (SI).

2. N.C.R = No Calibration Request.

8.3.TEST PROCEDURES

The EUT was placed on a turn table which was 0.8 meter above ground. The turn table can rotate 360 degrees to determine the position of the maximum emission level. The EUT was set 3 meters away from the receiving antenna which was mounted on a antenna tower. At the frequency band of 30MHz to 1GHz, The measuring antenna moved up and down to find out the maximum emission level. It moved from 1 to 4 m for horizontal and vertical polarizations. The broadband antenna (calibrated by dipole antenna) was used as a receiving antenna. At the frequency band of 1GHz to 2GHz, The measuring antenna moved from 1 to 4 m for horizontal and vertical polarization. The horn antenna was used as a receiving antenna.

The resolution bandwidth and video bandwidth of the test receiver was 120 KHz and 300KHz for Quasi-peak detection at frequency below 1GHz.

The resolution bandwidth and video bandwidth of the test receiver was 1MHz and 3MHz for Peak emission measurement above 1GHz .

The resolution bandwidth of the test receiver was 1MHz and the video bandwidth are 10Hz for Average emission measurement above 1GHz .

The EUT was tested in Chamber Site.

The test data of the worst case condition(s) was reported on the following pages.

8.4. TEST SETUP

Below 1GHz

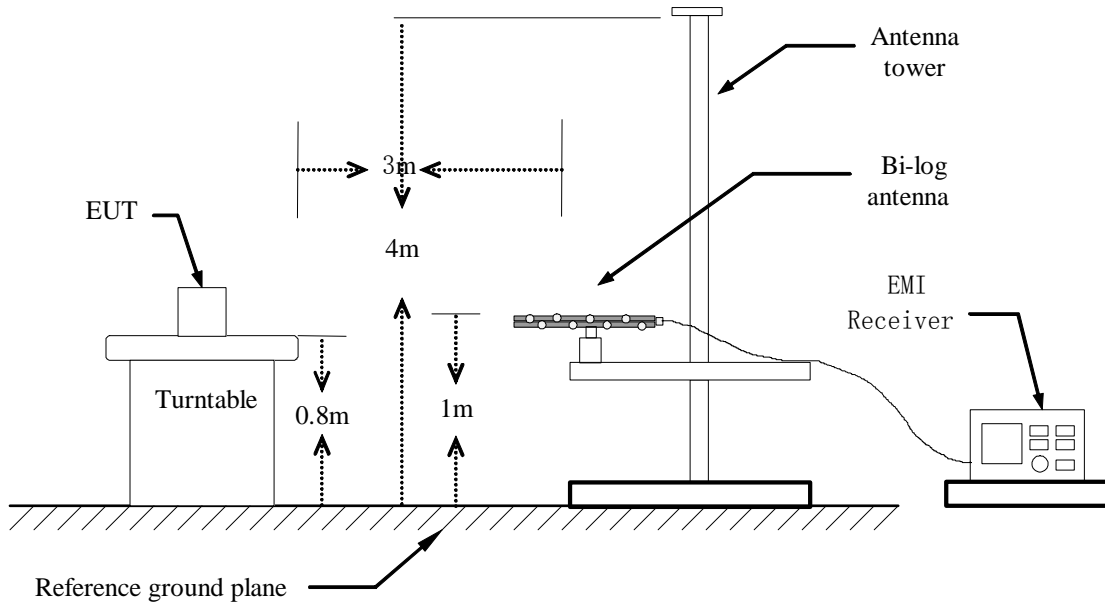

Above 1GHz

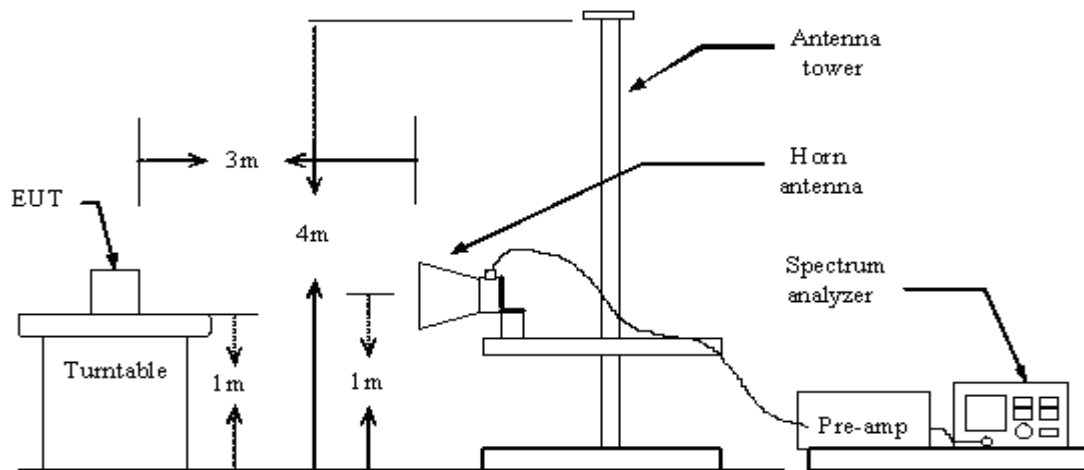

8.5.TEST RESULTS

Model No.	ATV500	Test Mode	Normal operation (worse case)
Environmental Conditions	25°C, 55% RH	Test Result	Pass

Frequency (MHz)	Ant. Pol.	Corr.Factor (dB)	Level (dBuV)	Limit (dBuV)	Margin	Note	Result
74.6200	H	-12.03	35.55	40.00	-4.45	QP	Pass
148.34	H	-6.83	30.56	43.50	-12.94	QP	Pass
223.03	H	-5.90	35.34	46.00	-10.66	QP	Pass
259.89	H	-4.52	34.54	46.00	-11.46	QP	Pass
296.75	H	-3.64	33.25	46.00	-12.75	QP	Pass
1238.00	H	26.51	47.50	74.00	-26.5	Peak	Pass
1238.00	H	26.51	--	54.00	--	AV	Pass
74.62	V	-11.64	31.82	40.00	-8.18	QP	Pass
200.72	V	-3.27	31.94	43.50	-11.56	QP	Pass
259.89	V	-3.60	30.43	46.00	-15.57	QP	Pass
296.75	V	-1.70	29.90	46.00	-16.1	QP	Pass
401.51	V	1.19	29.25	46.00	-16.75	QP	Pass
1200.00	V	26.50	48.53	74.00	-25.47	Peak	Pass
1200.00	V	26.50	--	54.00	--	AV	Pass

Note: 1. Level = Correction factor + Meter Reading

2. Correction factor=antenna factor + cable loss - preamplifier gain.

3. – means to the measure is no necessary, due to the PK value comply with AV limits.